

Branko Grünbaum

Preface to the notes on "Modern Elementary Geometry"

These notes were distributed to students taking the Math 553A course "Modern Elementary Geometry" given in Spring Quarter 1997 by Branko Grünbaum. They were written as the course was proceeding, and have not been modified for the present edition (except for the correction of obvious typos, and changes in the fonts that were used but are not supported in the newer versions of MSWord). Several copies were distributed in 1997 to peoples outside the course; among them was my frequent coauthor G. C. Shephard.

In the late 1980's and the early 1990's G. C. Shephard and I collaborated on various topics. One of these was a book on polygons we intended to write, and for which we developed the material for several chapters. We published some of the new results we obtained as journal articles, and they served as the basis for most of the sections of the first part of these lecture notes.

Other topics we developed we called "Relatives of Napoleon's theorem". This grew immensely through correspondence (much of it by e-mail) and during several visits by Shephard at the University of Washington. This material forms the basis of most sections of the second part of the course. As we investigated the field, and became aware of the work of others that had related results, the extent of the material grew, and we never reached a stage in which we thought that we can publish a paper of reasonable length in which this would be presented. The second part of the notes can serve as a confirmation of the length that this would require; Shephard was among the recipients of these notes.

Towards the end of 1999 I broke off all cooperation with Shephard. Since the work on "Napoleon's relatives" was a result of collaboration over several years, I did not publish any of it. It came as a complete surprise to me when Shephard published much of the material of the first six sections of the second part of these notes in a paper in which there is no mention whatsoever of our collaboration. The paper is "Sequences of

smoothed polygons"; it appeared in the volume *Discrete Geometry: In Honor of W. Kuperberg's 60th Birthday*. A. Bezdek, ed. Dekker, New York 2003, pp. 407 – 430.

While these notes were written during the Spring Quarter 1997, and since then, there have been various developments concerning the topics of the notes but not mentioned in the notes. The following remarks should help find most of these additional results.

Concerning the first part of the notes, I should mention the following:

Euler's results concerning sums of various ratios, mentioned in Section 4, have been generalized in several papers:

B. Grünbaum, Cyclic ratio sums and products, *Crux Mathematicorum* 24(1998), 20 – 25.

G. C. Shephard, Cyclic sums for polygons. *Math. Magazine* 72(1999), 126 – 132.

B. Grünbaum and M. S. Klamkin, Euler's ratio-sum theorem and generalizations. *Math. Magazine* 79(2006), 122 – 130.

The results of Section 5 were published in B. Grünbaum and G. C. Shephard, Ceva, Menelaus and Selftransversality. *Geometriae Dedicata* 65(1997), 179 – 192. A different generalization was presented in B. Grünbaum and G. C. Shephard, A new Ceva-type theorem. *Math. Gazette* 80(1996), 492 – 500.

Significant extensions of the material in Section 7 have appeared in papers by G. C. Shephard:

The Nehring-Reyes' theorems for polygons. *Nieuw Archief voor Wiskunde* (4) 16(1998), 1 – 20.

The polygon theorems of Pratt-Kasapi and Hoehn. *Geombinatorics* 9(1999), 76 – 89.

The complete Ceva. *Math. Magazine* 83(1999), 74 – 81.

Isomorphism invariants for projective configurations. *Canad. J. Math.* 51(1999), 1277 – 1299.

Pratt sequences and n -gons. *Discrete Math.* 221(2000), 125 – 154.

Parts of the material of Sections 8 and 9 were proved by a different method, and generalizations established in papers by G. C. Shephard:

Cyclic product theorems for polygons. I: Constructions using circles. *Discrete Comput. Geometry* 24(2000), 551 – 571.

Cyclic product theorems for polygons. II: Constructions using conic sections. *Discrete Comput. Geometry* 26(2001), 513 – 526.

The "Napoleon's theorem" part of the notes has an extensive bibliography — already in 1995 there were close to 200 references — and the topic attracts considerable interest to the present. I have added some more recent references, and attached the whole list at the end of these notes. The added references are distinguished by the letter N.

The material in Section N.7 and N.8 was developed by me alone; some of the contents of N.8 it was published in volume 7(1997/98) of the journal *Geombinatorics*.

Seattle, November 2009

MODERN ELEMENTARY GEOMETRY

1. Introduction.

Elementary Geometry studies the properties of finite sets of points, lines, segments, circles, and other similarly simple objects in the plane, in the 3-dimensional space, or — in some cases — in spaces of higher dimensions or in other settings. The traditional Elementary Geometry had its start in antiquity, with some well known properties of right triangles (theorem of Thales, theorem of Pythagoras).

Although its scope widened over the intervening millennia, Elementary Geometry can still be said to center on the geometry of triangles. There are scores of "remarkable points" associated with triangles, as well as an assortment of numbers, lines, circles, triangles, and other objects. A recent survey (Kimberling [1994]) lists more than one hundred "remarkable points" and hundreds of "remarkable lines" ! In fact, with only a small effort the number of such objects could be increased at will, though with an attendant loss of interest. This would repeat an analogous historical development: About a century ago, there was a flourishing branch of geometry which went by the name "Triangle Geometry", devoted to pursuing the "remarkable points" and their relatives. However, the more intense and detailed the study of triangles became, the less interest in this study was evinced by the rest of mathematicians. (See Davis [1995] for a discussion of this topic.) Triangle geometry, and with it much of elementary geometry, was soon excised from the body of active mathematics and from higher education; only minor fragments of it were relegated to high school mathematics.

The purpose of this course is to show that Elementary Geometry leads to many new results, insights, and connections to other branches of mathematics. Many of these can be found by extending the investigations from triangles to general polygons, and by an analogous widening of the scope of other elementary constructions. Such considerations have resulted in many interesting problems, which are trivial or even meaningless for triangles. During the last few years this approach has led to a renewal of interest in questions which can be considered as "Elementary Geometry". We shall discuss several newly developed directions and a number of promising topics of further inquiry. We shall consider the various methodologies that are applicable to such studies, as well as applications to other areas of mathematics.

A large role in the revival of elementary geometry is played by computers — both as tools and as sources of new topics. However, while giving computational aspects a deservedly large role, our treatment will try to emphasize the whole spectrum of applicable methods of proof, and of searches for possible generalizations of known results.

Although a survey like the present one cannot be exhaustive, in the topics considered we shall strive for an exposition that is as up-to-date as possible.

The above generalities will now be illustrated by several examples, hinted at in Figures 1.1, 1.2 and 1.3.

In Figure 1.1 we show the four traditional "remarkable points" and the line and circles to which they lead. Although the generation of these four points follows very similar steps ("The three lines ... are concurrent") we shall see that in a more general setting they lead to very different objects, which exhibit quite distinct properties.

Figure 1.2 shows a more recently discovered property of triangles, which goes by the name "Napoleon's theorem", although its relation to the French emperor is rather unclear. The theorem asserts that if equilateral triangles are constructed on the sides of an arbitrary triangle, all towards the outside or all towards the inside, then their centroids will be the vertices of an equilateral triangle.

In Figure 1.3 we illustrate another famous theorem, associated with the names of Newton and Gauss. Four lines in "general position" (no two parallel, no three concurrent) meet in six points. These points form three pairs of points such that the two points of a pair are not contained in any one of the starting lines. These pairs determine the three "diagonals" of the set of four lines. The theorem in question states that the midpoints of the three diagonals are collinear.

Our program is as follows.

We shall start by showing how the four "remarkable points" of Figure 1.1 can be derived in a uniform way using a result known as the theorem of Ceva. Then we shall discuss a number of generalizations and relatives of Ceva's theorem. Following this we shall investigate the generalizations of the individual "remarkable points" to polygons and other appropriate objects. This will lead to a mostly unexplored territory.

Centroid:
point
of concurrence
of the three
medians.

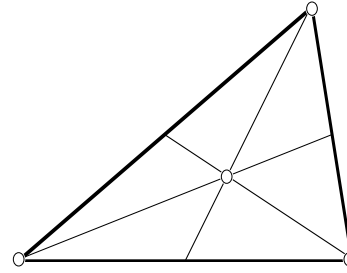
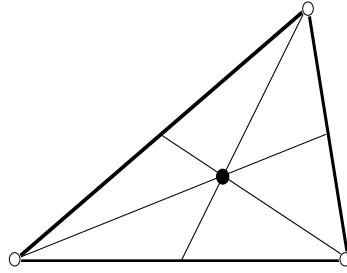

Orthocenter:
point of
concurrence
of the three
altitudes

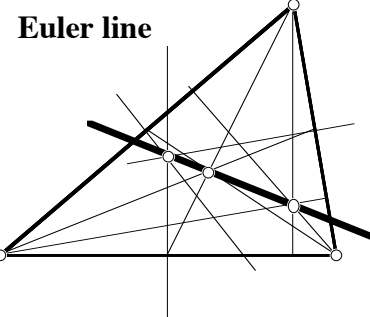
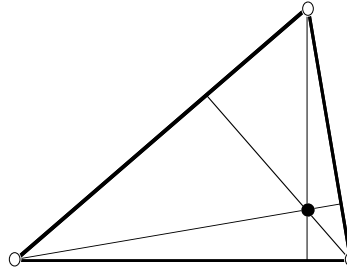

Circumcenter:
point of
concurrence
of the three
perpendicular
bisectors of the
sides

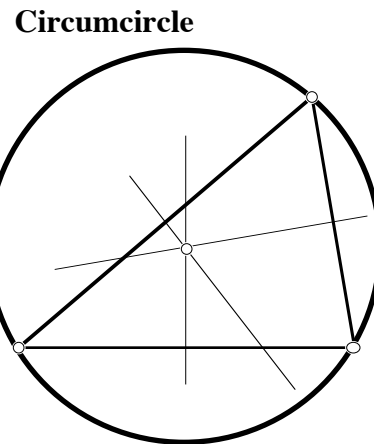
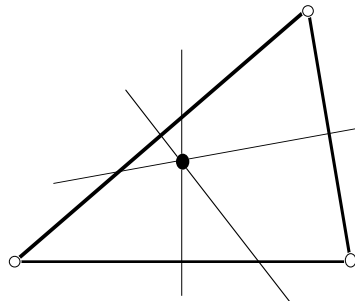

Incenter:
point of
concurrence
of the three
angle bisectors

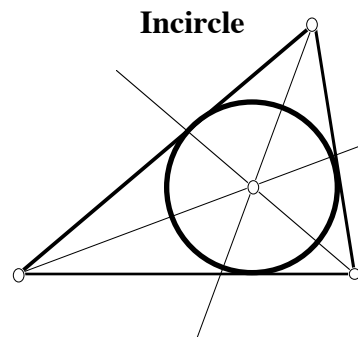
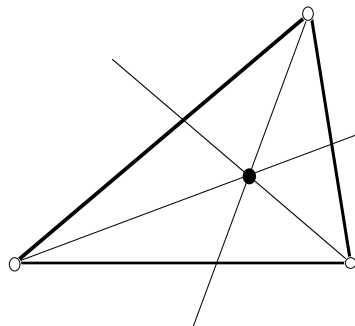

Figure 1.1. The four traditional "remarkable points" of a triangle, and the two circles and one line to which they lead.

The investigation of Napoleon's theorem and its relatives will lead us to an algebra of polygons, which will turn out to be extremely useful in the study of very general iterative constructions on polygons. It will also lead to a variety of other results, and unify many seemingly unrelated facts. Parts of this material have been known for some time, but it seems that the full potential of the methods used has not been realized.

The Newton-Gauss line is the starting points for several families of results that deal with finite families of lines. There is a remarkable collection of results leading to points, lines, circles and other objects, associated with the names of Steiner, Wallace, Clifford, de Longchamps.

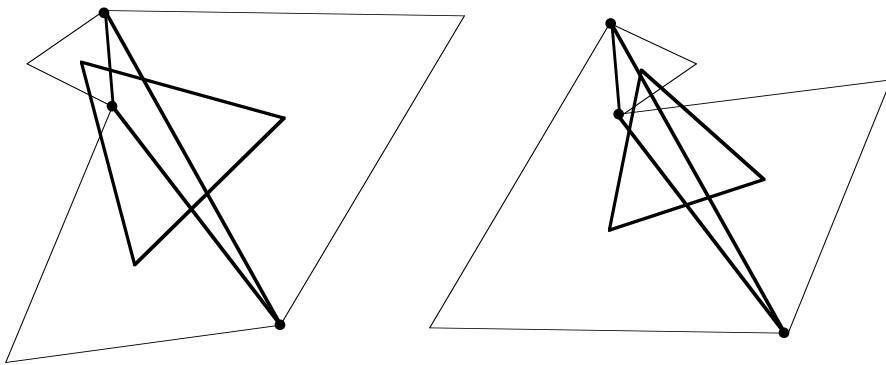

Figure 1.2. "Napoleon's theorem" starts with an arbitrary triangle and leads to two equilateral triangles.

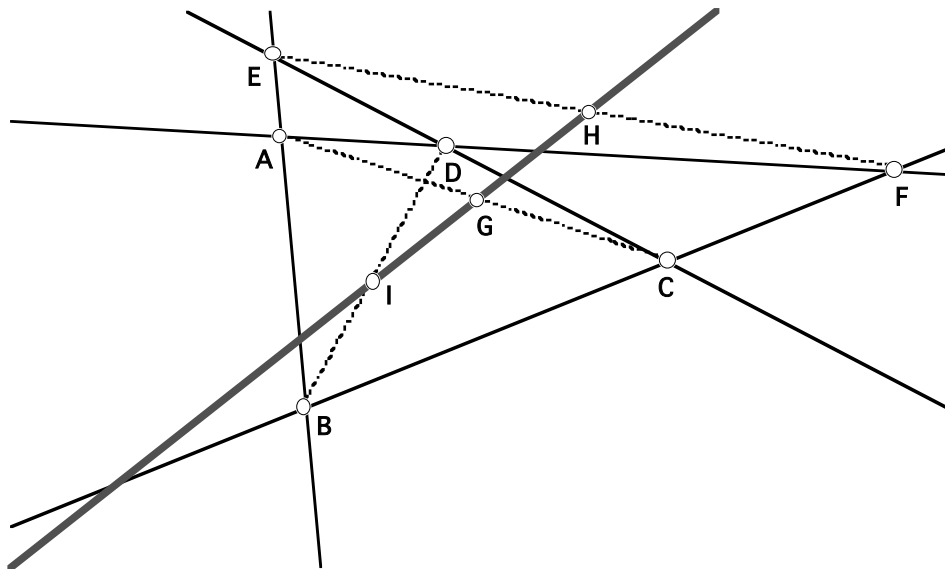

Figure 1.3. The Newton-Gauss line of a quadrilateral. Starting with four lines in general position, three "diagonals" are determined; their midpoints are collinear, on the Newton-Gauss line.

Remarks and exercises.

(1) There are several books that contain, in one form or another, much of the material mentioned above and cover many other topics of a similar kind. The following is a brief list, which does not contain the countless books of the "College Geometry" type.

Coxeter [1980] and Coxeter & Greitzer [1967] are very attractive books with a wealth of material, presented in an accessible way.

Altshiller–Court [1952] and Johnson [1960] contain much more detail and material; while the former is more leisurely organized, the latter covers more ground but is a bit inconvenient to use since it requires some jumping back and forth to follow its proofs. Both are rather old-fashioned, their first editions are from 1925 and 1929, respectively.

Eves [1963] is a more modern presentation, with many results presented in exercises.

Chou, Gao & Zhang [1994] is an extraordinary book. It explains a method of computer verification of theorems covering a considerable part of elementary geometry, in a format that allows an easy translation into traditionally presented proofs. However, the reason for mentioning it here is that it contains a huge list of theorems of elementary geometry.

(2) It may be noted that the centroid of a triangle plays a double role: it is the **vertex centroid**, the center of gravity of three equal masses placed at the vertices, and also the **area centroid**, center of gravity of a mass homogeneously distributed over the interior of the triangle. This is worth mentioning since it **does not** generalize to polygons with more sides.

(3) Challenge: Locate the **perimeter centroid** of a triangle, that is, the center of gravity of a mass distributed uniformly along the edges of the triangle.

References.

N. Altshiller–Court, *College Geometry. An Introduction to the Modern Geometry of the Triangle and the Circle*. Barnes & Noble, New York 1952.

S.-C. Chou, X.-S. Gao and J.-Z. Zhang, *Machine Proofs in Geometry. Automated Production of Readable Proofs for Geometry Theorems*. World Scientific, Singapore 1994.

H. M. S. Coxeter, *Introduction to Geometry*. 2nd ed. Wiley, New York 1980.

P. J. Davis, The rise, fall, and possible transfiguration of triangle geometry: a mini-history. *Amer. Math. Monthly* 102(1995), 204 - 214.

H. Eves, *A Survey of Geometry*. Vols. 1 and 2. Allyn & Bacon, Boston 1963.

R. A. Johnson, *Advanced Euclidean Geometry. An Elementary Treatise on the Geometry of the Triangle and the Circle*. Dover, New York 1960.

C. Kimberling, Central points and central lines in the plane of a triangle. *Math. Magazine* 67(1994), 163 - 187.

2. The classical theorem of Ceva.

The traditional version of the theorem of Ceva (which goes back to the 17th century; Giovanni Ceva, 1647 – 1734) is as follows; for convenience, we split it into two parts.

Ceva's theorem.

(a) Direct part: If the lines through a point O and the vertices of a triangle $T = \triangle ABC$ intersect the opposite sides in points A^*, B^*, C^* as shown in Figure 2.1, then

$$(*) \quad \frac{AC^*}{C^*B} \cdot \frac{BA^*}{A^*C} \cdot \frac{CB^*}{B^*A} = 1.$$

(b) Converse part: If A^*, B^*, C^* are points on the sides of T and $(*)$ holds, then the lines AA^*, BB^*, CC^* are concurrent at some point O .

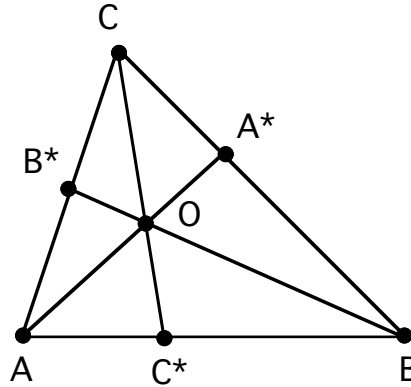

Figure 2.1. An illustration of Ceva's theorem: $\frac{AC^*}{C^*B} \cdot \frac{BA^*}{A^*C} \cdot \frac{CB^*}{B^*A} = 1$ if and only if the lines AA^*, BB^*, CC^* are concurrent.

The above is a rather sloppy formulation; to make it precise, we have to add a few explanations and assumptions.

To begin with, we shall assume that each side of the triangle is oriented in one of the two possible directions; as it turns out, it does not matter which direction is chosen. Since in the generalizations it is sometimes convenient to have the sides of polygons oriented in a consistent manner, we may just as well assume already here such a consistent orientation. A segment PQ on an oriented line may be assigned a **signed length** — its usual length with a positive sign if the vector from P to Q agrees with the orientation of the line, and with a negative sign otherwise. Since each ratio in $(*)$ involves collinear segments, the value of the ratio is a real number (positive, negative, or zero) which does not depend on the orientation of the line. We shall agree that

throughout our discussion, we shall consider ratios of segments only if they are carried by the same line, and in this case we shall always consider the ratio to be a real number, as explained above.

Second, we shall assume, here and throughout, that all the ratios appearing in the statements of results are well defined. This means, in particular, that the intersection points used are actually defined (so that the lines involved are neither coinciding nor parallel), and that the segments are not reduced to single points. As a direct consequence of this assumption, we see that the point O cannot lie on any of the edges of T or their extensions. In fact, we find it convenient to adopt a terminology that is more specific than is customary. For a triangle $T = \triangle ABC$ each of the segments AB , BC , CA will be called an **edge** of T , while each of the lines determined by these segments will be called a **side** of T . This is the meaning of "side" and "edge" that should be understood in our formulation of Ceva's theorem, and in the comment above (which can now be shortened to: O does not lie on any side of T). In accordance with this, we shall from now on distinguish in diagrams and in text between sides (which are unbounded lines) and edges (which are segments).

Finally, notice that the point O in Ceva's theorem does not have to be contained in the interior of the T ; hence there are three different illustrations one may wish to give for the theorem — see Figure 2.2.

Proof. The literature contains many different proofs of Ceva's theorem. The proof we shall give was chosen because it uses an idea that can be applied in countless other cases. But before giving the proof of the direct part, we observe that the converse part is an immediate consequence of the direct one: Let A^* , B^* , C^* be given (on the appropriate sides of $T = \triangle ABC$), such that (*) holds. Let O be the intersection point of AA^* and BB^* , and let C^{**} be the intersection point of AB and CO . By the direct part of the theorem,

$$\frac{AC^{**}}{C^{**}B} \cdot \frac{BA^*}{A^*C} \cdot \frac{CB^*}{B^*A} = 1.$$

Combining this with (*) we find that

$$\frac{AC^{**}}{C^{**}B} = \frac{AC^*}{C^*B}, \text{ and hence } C^{**} = C^*.$$

As to the direct part, we use what is called the **area principle**: This is the observation that $\frac{AC^*}{C^*B} = \frac{\text{area}(\triangle OCA)}{\text{area}(\triangle OBC)}$, where the areas are also taken as signed numbers (positive if the orientation is counterclockwise, negative otherwise). To

simplify the expressions, in the sequel we shall denote such ratios by placing the signed lengths or areas in outlined brackets, so that the area principle can be written simply in the form $\left[\frac{AC^*}{C^*B} \right] = \left[\frac{ACO}{CBO} \right]$. Then, using the area principle and cancellation, we have

$$\left[\frac{AC^*}{C^*B} \right] \cdot \left[\frac{BA^*}{A^*C} \right] \cdot \left[\frac{CB^*}{B^*A} \right] = \left[\frac{ACO}{CBO} \right] \cdot \left[\frac{BAO}{ACO} \right] \cdot \left[\frac{CBO}{BAO} \right] = 1.$$

Having the converse part of Ceva's theorem at our disposal, it is easy to prove the existence of the four "remarkable points" of Section 1. The most straightforward is the centroid: Since each of the medians passes through the midpoint of an edge, each of the three ratios is equal to 1; hence the three medians meet at a point, which is usually called the **centroid** of the triangle.

To show that the three altitudes are concurrent (at the **orthocenter** of the triangle) we note that in the notation of Figure 2.3 we have

$$\begin{aligned} AC^* &= AC \cos \alpha, & C^*B &= CB \cos \beta, \\ BA^* &= BA \cos \beta, & A^*C &= AC \cos \gamma, \\ CB^* &= CB \cos \gamma, & B^*A &= BA \cos \alpha, \end{aligned}$$

where α, β, γ are the angles at the vertices A, B, C . Substituting these values we see that (*) is satisfied, hence the three altitudes meet at a point.

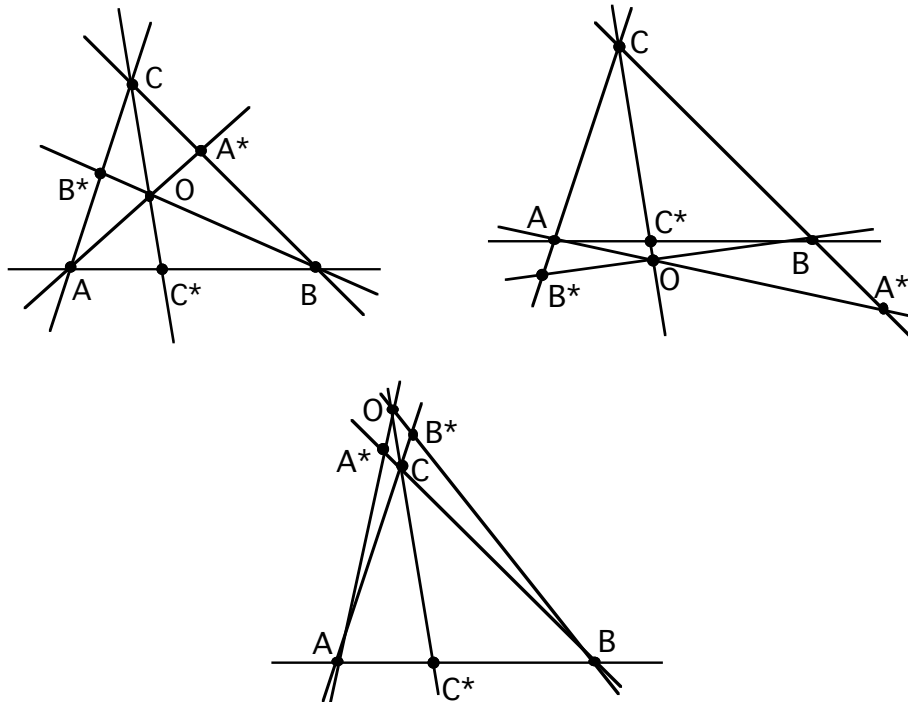

Figure 2.2. The three distinct positions of the point O of Ceva's theorem.

The existence of the **circumcenter**, the meeting point of the three perpendicular bisectors of the edges of the triangle, now follows at once on noticing (in the notation of Figure 2.4) that the perpendicular bisectors of the edges of $\triangle ABC$ are the altitudes of $\triangle A^*B^*C^*$.

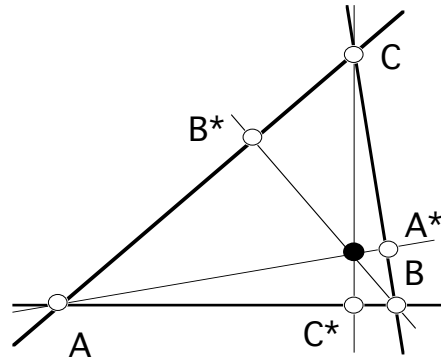

Figure 2.3. Notation for the proof of the existence of the orthocenter, the point of concurrence of the three altitudes.

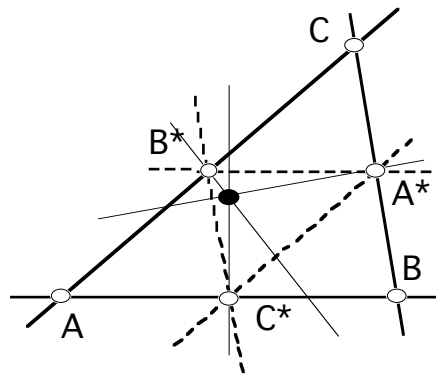

Figure 2.4. Notation for the proof of the existence of the circumcenter of $\triangle ABC$, which coincides with the orthocenter of $\triangle A^*B^*C^*$.

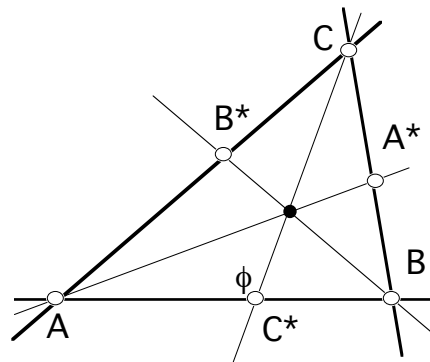

Figure 2.5. Notation for the proof of existence of the incenter, the point of concurrence of the three angle-bisectors.

To show the existence of the **incenter**, we note that (in the notation of Figure 2.5, and using the sine theorem) $\frac{AC^*}{\sin(\gamma/2)} = \frac{AC}{\sin \phi}$ and $\frac{C^*B}{\sin(\gamma/2)} = \frac{CB}{\sin(\pi-\phi)} = \frac{CB}{\sin \phi}$, etc. Substituting and cancelling, we see that (*) again holds.

We end this section with an ancient result, usually known as the Theorem of Menelaus (first century AD). We shall again state it in two parts.

Menelaus's theorem.

(a) Direct part: Let a triangle $T = \Delta ABC$ and a transversal line t be given, such that t does not pass through any vertex of T and is not parallel to any side of T . Let t intersect the sides of T in A^*, B^*, C^* as illustrated in Figure 2.6. Then

$$(**) \quad \left[\frac{AC^*}{C^*B} \right] \cdot \left[\frac{BA^*}{A^*C} \right] \cdot \left[\frac{CB^*}{B^*A} \right] = -1.$$

(b) Converse part: If C^*, A^*, B^* are points on the sides AB, BC, CA of a triangle $T = \Delta ABC$, and if (**) holds, then A^*, B^*, C^* are collinear.

It may be noted that the transversal t need not intersect the interior of the triangle.

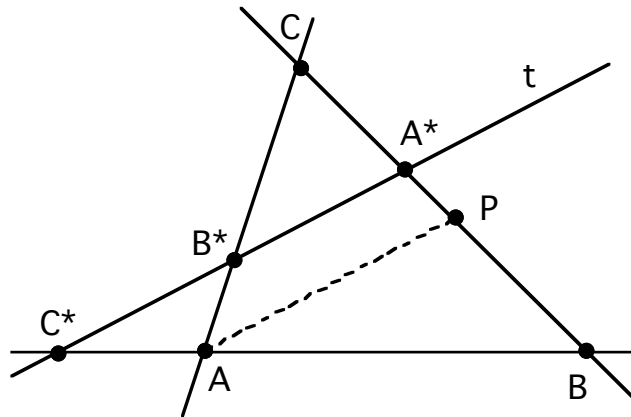

Figure 2.6. An illustration of the theorem of Menelaus and its proof.

Proof. Direct part. Let P be the intersection point of BC and the line parallel to t and passing through A . Then, by the proportionality of transversals between parallel lines, we have

$$\left[\frac{AC^*}{C^*B} \right] \cdot \left[\frac{BA^*}{A^*C} \right] \cdot \left[\frac{CB^*}{B^*A} \right] = \left[\frac{PA^*}{A^*B} \right] \cdot \left[\frac{BA^*}{A^*C} \right] \cdot \left[\frac{CA^*}{A^*P} \right] = -1.$$

Converse part. Let C^{**} be the intersection point of the line through A^* and B^* with the side AB . By the direct part, $\left[\frac{AC^{**}}{C^{**}B} \right] \cdot \left[\frac{BA^*}{A^*C} \right] \cdot \left[\frac{CB^*}{B^*A} \right] = -1$. From this and (***) it follows that $\left[\frac{AC^{**}}{C^{**}B} \right] = \left[\frac{AC^*}{C^*B} \right]$, which implies $C^* = C^{**}$. Hence A^*, B^*, C^* are collinear, as claimed. ,

Remarks and Exercises.

(1) Formulate the geometric statement which holds in the cases excluded in Ceva's theorem.

(2) Thinking in terms of coordinate geometry, it is clear that the theorem of Ceva is equivalent to saying that a polynomial (of degree at most 18, I think) involving the eight coordinates of the points A, B, C, O is 0 for all (or, at least, for almost all) choices of values for the variables. This can happen only if the polynomial is identically zero, and it only shows that equivalent formulations of a fact may differ greatly in their aesthetic appeal, and in their applicability.

(3) Find in explicit form a polynomial of the kind mentioned in (2) above, so that its being identically 0 is equivalent to Ceva's theorem. How low a degree can you get ?

(4) The proof of Menelaus' theorem given above is based on the following trivial fact:

Let A, B, C, P be distinct and collinear points. Then $\left[\frac{PA}{AB} \right] \cdot \left[\frac{BA}{AC} \right] \cdot \left[\frac{CA}{AP} \right] = -1$.

Similarly trivial is the relation $\left[\frac{AP}{PB} \right] \cdot \left[\frac{PB}{CP} \right] \cdot \left[\frac{PC}{PA} \right] = -1$. We shall later see that these fit into a family of nontrivial results.

(5) If the triangle is given by the coordinates of its vertices (or by the corresponding vectors v_1, v_2, v_3) the centroid is obviously given by the expression $(v_1 + v_2 + v_3)/3$. Find an expression (in terms of coordinates) for the circumcenter of such a triangle. What about the orthocenter, or the incenter ?

(6) A general suggestion, intended to provide mental exercise, as well as practice in guessing (and possibly proving) generalizations of known results: Try to find generalizations to higher-dimensional simplices of the results on triangles we have seen. Strange as it may seem, this is usually much easier than finding generalizations to polygons with more than three sides.

3. **Polygons, multilaterals, polyacrons.**

Our next goal is the generalization of the theorem of Ceva (and its relatives) to the case of polygons. However, there is an obstacle that has to be overcome before we can meaningfully do this: We have to make sure our terminology fits our intentions.

Polygons are familiar geometric objects which have been studied and used in practical applications since antiquity. Over the millenia, many of their properties have been elucidated, but a considerable amount of confusion exists regarding the precise definition of the concepts, and the range of validity of various results. This is in large part due to the versatility of polygons, and the different directions in which their theory has been developed. For example, convex polygons have properties shared with more general convex sets, as well as with higher-dimensional convex sets and polytopes. On the other hand, convexity of the polygons is entirely irrelevant to studies of many of their affine or topological properties; in fact, if attention is restricted to convex polygons many of these properties are completely hidden or insignificant. Other dilemmas arise in the distinctions between polygons with or without selfintersections, with various kinds of collinearities or coincidences, and in many other respects. Naturally, there is no "right" definition which should replace all others — different contexts are best served by appropriate delimitations of the objects investigated.

Some examples should help clarify the above musings. If one is interested in relations between the perimeter of a polygon and the area of the region enclosed by it, convex polygons are the natural objects of study. Regardless of whether more general polygons are admitted or not, the attention is soon restricted to convex ones. On the other hand, if the possible kinds of selfintersection of a polygon are investigated, convex polygons present an extremely uninteresting case. In still a different direction, even some classical results that are usually formulated for polygons (or, at least, for triangles, such as much of the material in Section 2) deal in fact not with polygons as such — that is, polygons understood as closed curves formed by straight-line segments — but with the lines that carry the edges of the polygons.

The one aspect of polygons that is fundamental is their cyclicity: Going from one vertex to an adjacent one leads after finitely many steps to the starting vertex, having visited all the vertices. Whether one wishes to think of the segments between adjacent vertices or the lines generated by these, and regardless of whether coincidences and

selfintersections are permitted or not, this cyclic character distinguishes polygons from other geometric figures. For this reason we shall start our study with just this kind of objects: finite cyclic sets of points. Various kinds of polygons, or polygon-like objects, can then be defined, and their properties established without confusion or prejudicial limitations. Our presentation will be guided by the vast amount of knowledge that has been accumulating over the centuries without ever being systematized.

One reason for the desirability of such a systematization at the present time is that many new directions of investigation have been opened up by the advent of computers and computer graphics. These made possible the experimental quest for properties, on a scale that could not have been imagined even a single generation ago. As we shall see, many results that have traditionally been considered as limited to triangles can be meaningfully extended to much more general situations.

Given any set S — the "space" in which we shall be working — and a positive integer n , an **n-acron** P is a collection (V_1, V_2, \dots, V_n) of labeled elements of S , considered as **cyclically ordered**. By this is meant that V_{i+1} is taken as following V_i for $i = 1, 2, \dots, n-1$, and that V_1 follows V_n . Such pairs of points are said to be **adjacent** to each other. To emphasize this aspect of n -acrons we use the round parentheses instead of the curly brackets used for sets. The points V_i are called the **vertices** of the n -acron P . In most cases (but not always!) it is convenient to assume that $n > 1$, thus eliminating **1-acrons** or **monogons**, the inclusion of which would frequently render statements trivial, or in need of special provisions. Also, very often it is appropriate to assume that **2-acrons** or **digons** are excluded, for similar reasons. However, we shall try to give all definitions in as general a way as possible, so as not to preclude the consideration of these and other special cases. Due to the cyclic character of n -acrons, we do not distinguish between (V_1, V_2, \dots, V_n) and $(V_2, V_3, \dots, V_n, V_1)$ or any other ways of writing the vertices in a cyclic permutation of the original list. However, for $n \geq 3$, the n -acron (V_n, \dots, V_2, V_1) is different from the n -acron (V_1, V_2, \dots, V_n) . It is said to be obtained from the latter by **reversing the orientation**.

While there is no inherent restriction on what the space S should be, we shall limit our considerations to the Euclidean d -spaces \mathbf{E}^d , for suitable dimensions d . In fact, most of the time we shall be assuming that $d = 2$, although other choices are at times convenient or necessary. As will be pointed out in appropriate places, for many of the results it is possible to assume that the space is the real d -dimensional affine space \mathbf{A}^d , since the special Euclidean metric is not relevant.

We made no restriction concerning the coincidences of the vertices of n -acrons. Thus, it is possible for all of them to coincide — in which case we will call the n -acron **trivial**. It should be noted that if $n > 1$ the trivial n -acron is an object quite different from a monogon.

With each n -acron $P = (V_1, V_2, \dots, V_n)$ we can associate two related objects:

(a) the **n -gon** $[V_1, V_2, \dots, V_n]$ is the **polygon**, as this word is generally understood; specifically, this is the collection, cyclically ordered, of the **vertices** V_i and the **edges** $[V_i, V_{i+1}]$, that is, straight-line segments with endpoints V_i and V_{i+1} . The coincidence of the two endpoints of an edge is not excluded; in this case the edge is reduced to a single point.

(b) the **n -lateral** $\langle V_1, V_2, \dots, V_n \rangle$ is a **multilateral**; specifically, this is the cyclically ordered collection of the **vertices** V_i and the **sides** $\langle V_i, V_{i+1} \rangle$, that is, straight lines determined by the points V_i and V_{i+1} . If adjacent points V_i and V_{i+1} coincide, a decision needs to be made and specified concerning the side $\langle V_i, V_{i+1} \rangle$. In some cases it is appropriate to understand $\langle V_i, V_{i+1} \rangle$ as a point, in others as any line through that point; at times it is most appropriate to exclude such multilaterals from consideration. In necessary, we shall indicate what is to be assumed in a specific case.

We shall say that the n -gon $[V_1, V_2, \dots, V_n]$ and the n -lateral $\langle V_1, V_2, \dots, V_n \rangle$ have (V_1, V_2, \dots, V_n) as the **underlying** n -acron, or **underlying set of vertices**.

An n -gon is said to be **simple** if no point of the plane lies on three or more edges of the n -gon, and no point belongs to the relative interior of two or more edges. Such polygons are also known as **Jordan polygons**.

Two more concepts are needed. Any (unordered) collection of n labeled points is called an **n -set** (or a **polyset**, if the value of n is unimportant or not known). The difference from a set of points in the usual sense is that without the labels the points of a polyset may not be distinct. However, we shall use curly brackets, the notation customary for ordinary sets, for polysets as well. Similarly, any unordered collection of n straight lines will be called an **n -line** (or a **polyline**). For example, the Newton-Gauss line mentioned in Section 1 is defined for certain 4-lines.

Remarks and exercises.

(1) It is easy to verify that an n -set consisting of $n \geq 3$ distinct points can be cyclically ordered in such a way that it is the underlying set of vertices of a simple polygon if and only if the n -set is not contained in one line. Since an unordered set of n distinct points can be cyclically ordered in $(n-1)!$ ways, that is, leads to $(n-1)!$ distinct n -acrons, and hence to the same number of distinct n -gons. However, it is not known what is the maximal number $s(n)$ of possible cyclic orderings of a suitable n -set that are underlying sets of vertices of *simple* n -gons. For $n = 3$ or $n = 4$ the upper bound $s(n) = (n-1)!$ is attained. It can be shown that $s(5) = 16 < 24$, but already the value of $s(6)$ is not known. It is also not known whether for every k with $0 \leq k \leq s(n)$ there is an n -set such that there are precisely k distinct simple polygons obtainable by different cyclic orderings of the n -set.

(2) Show that there exists a 9-lateral M with distinct vertices, such that each of its sides contains a vertex of M other than the two that determine the side.

* Show that no such n -lateral exists for $n \leq 8$, but that there are n -laterals of this kind for every $n \geq 9$.

(3) Find at least one example of an n -lateral M with all vertices distinct and all sides distinct, such that each side of M contains two vertices of M in addition to the two that determine the side.

(4) For certain even values of n , there exist Jordan n -gons G with no three consecutive vertices collinear, such that all the edges of G are contained in $\lfloor n/2 \rfloor$ lines. Find some examples.

** A characterization of the possible values of n for this to happen is not known. What is the least number of lines needed to contain all edges of some such n -gon with odd n ? Can all the edges of such an n -gon be contained in fewer than $\lfloor (n+1)/2 \rfloor$ lines?

(5) Let P be an n -set consisting of distinct points, and let $\lambda(P)$ be the number of distinct lines determined by the points of A . Clearly $1 \leq \lambda(P) \leq n(n-1)/2$. However, not every integer in this interval is a possible value of $\lambda(P)$. Can you determine the possible values of $\lambda(P)$ in case $n = 8$? An analogous (but different) problem concerns the number $\pi(L)$ of distinct points that can be determined by an n -line L consisting of distinct lines. Clearly $0 \leq \pi(L) \leq n(n-1)/2$. Can you determine the possible values of $\pi(L)$ in case $n = 8$?

4. Ceva, Menelaus and Selftransversality.

The theorems of Ceva and Menelaus formulated and proved in Section 2 are well-known results in classical elementary geometry. Both express facts about products of certain cyclic ratios of lengths of segments determined on the sides of triangles by either a suitable point, or a suitable transversal line. These theorems have been extended in various ways, some of which are specified below and in the exercises. Other results concerning cyclic products of ratios have been found recently, in joint work with G. C. Shephard. We shall discuss some of these as well. In all the following discussions we shall assume, without repeating it every time, that the points and lines in question are such that all the ratios are well defined.

We start with the following generalization of Ceva's theorem, which is found in many geometry texts; here it is formulated in our terminology. We recall that if A, B, C, D are distinct collinear points, we write $\left[\frac{AB}{CD} \right]$ for the ratio of the length of the segment $[A,B]$ to the length of the segment $[C,D]$, taken with a positive or a negative sign depending on whether the two segments are oriented the same way, or oppositely oriented.

Generalized theorem of Ceva.

Direct part. Let $n = 2m + 1$ be an odd integer, $M = \langle V_1, V_2, \dots, V_n \rangle$ an n -lateral, Q a point of the plane not collinear with any two vertices of M . If the line $\langle V_i, Q \rangle$ intersects the line $\langle V_{i+m}, V_{i+m+1} \rangle$ in the point W_i , then

$$(*) \quad \prod_{i=1}^n \left[\frac{V_{i+m} W_i}{W_i V_{i+m+1}} \right] = 1.$$

Converse part. Let $n = 2m + 1$ be an odd integer, let $M = \langle V_1, V_2, \dots, V_n \rangle$ be an n -lateral, let W_i be collinear with V_{i+m} and V_{i+m+1} but distinct from them, let $n-1$ of the lines $\langle V_i, W_i \rangle$ be concurrent, and let $(*)$ hold. Then all n lines $\langle V_i, W_i \rangle$ are concurrent.

The classical theorem of Ceva is the case $n = 3$.

Proof. As in Section 2, the proof of the direct part relies on the following **area principle**. Let D be the point of intersection of the lines $\langle B,C \rangle$ and $\langle A_1, A_2 \rangle$. Using the signed lengths of the segments, and the signed areas of the triangles involved, the area

We next consider the generalization of the theorem of Menelaus, which was first formulated by Carnot [1803]. We state only the direct part, since the formulation and proof of the converse follow exactly the same pattern as in the previous proofs:

The theorem of Menelaus and Carnot.

If a line L meets the side $\langle V_i, V_{i+1} \rangle$ of an n -lateral $M = \langle V_1, V_2, \dots, V_n \rangle$ in a point X_i , then

$$\prod_{i=1}^n \left[\frac{V_i X_i}{X_i V_{i+1}} \right] = (-1)^n .$$

You should by now be able to formulate several different proofs for this assertion.

* * * * *

Stopping to contemplate the results we have just found, we can come up with the following observation: Both theorems deal with circular products of ratios of segments determined on each side of an n -lateral by a transversal line. The difference between the two theorems is that in the case of Menelaus's theorem there is a fixed line — or, we could say, a line determined by some two fixed points — while in Ceva's theorem each line is determined by one point that is fixed, and one vertex of the n -lateral. This makes it reasonable to wonder whether there is a third theorem, in which each transversal line is determined by two vertices of the n -lateral. As it turns out, there is such a result, which we call the "selftransversality theorem". Since the sides of the n -lateral play a role equal to that of its "diagonals", it is appropriate to formulate it for polyacrons.

The Selftransversality Theorem.

Let j, r, s be integers distinct (mod n). For any n -acron $P = (V_1, V_2, \dots, V_n)$ in the plane, we denote by W_i the intersection point of the line $\langle V_i, V_{i+j} \rangle$ with the line $\langle V_{i+r}, V_{i+s} \rangle$. Assuming that all the ratios are well defined, a necessary and sufficient condition for

$$\prod_{i=1}^n \left[\frac{V_i W_i}{W_i V_{i+j}} \right] = (-1)^n$$

to hold for an arbitrary P of this kind is that

either (i) $n = 2m$ is even, $j \equiv m$ and $s \equiv r + m$;
 or (ii) n is arbitrary and
 either (ii.a) $s \equiv 2r$ and $j \equiv 3r$;
 or (ii.b) $r \equiv 2s$ and $j \equiv 3s$
 (all congruences are mod n).

This is illustrated in Figure 4.3 in cases (i) $n = 6, j = 3, r = 1, s = 4$; (ii) $n = 5, j = 2, r = 3, s = 4$; and (iii) $n = 7, j = 1, r = 3, s = 5$.

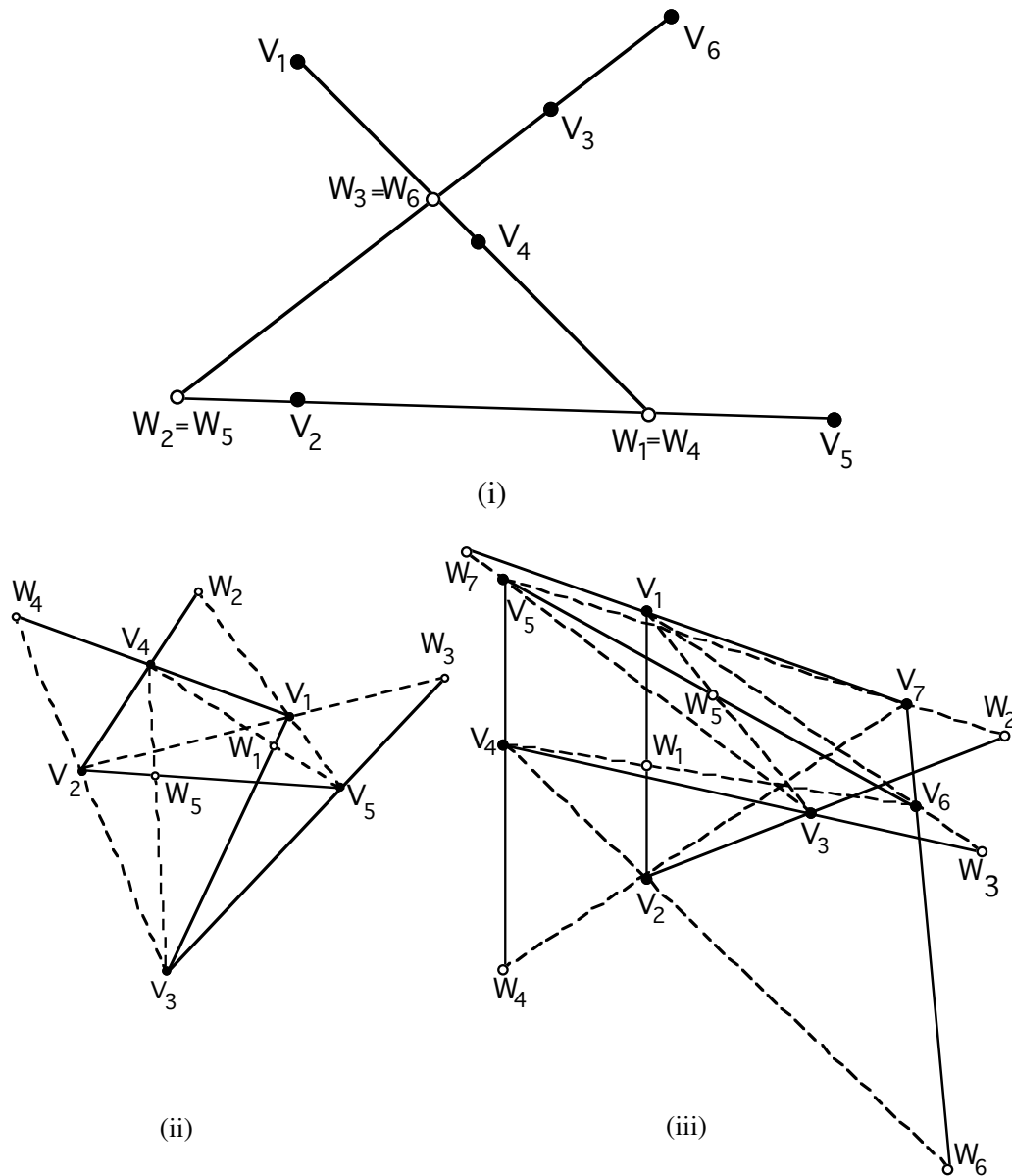

Figure 4.3. Three examples illustrating the Selftransversality Theorem. The product of the appropriate ratios is 1 in (i), and -1 in (ii) and (iii). To avoid clutter, all lines have been clipped as much as possible.

Proof. For the proof of the selftransversality theorem we use the area principle for triangles with basis $[V_{i+r}, V_{i+s}]$ and apices V_i and V_{i+j} , and we obtain

$$\left[\frac{V_i W_i}{W_i V_{i+j}} \right] = - \left[\frac{V_i V_{i+r} V_{i+s}}{V_{i+j} V_{i+r} V_{i+s}} \right].$$

We substitute these expressions for each of the n factors on the left side of the product in the theorem and determine when exactly the same triangles occur in both the numerator and denominator. Then (and only then) their areas (as expressed in terms of determinants) will cancel, to yield the value ± 1 as required. The term $V_i V_{i+r} V_{i+s}$ in the numerator will cancel with the term $V_{(i+h)+j} V_{(i+h)+r} V_{(i+h)+s}$ in the denominator if and only if either

- (i) $h \equiv -j$, $r \equiv s - j$ and $s \equiv r - j$; or
- (ii) $h \equiv -r$, $r \equiv s - r$ and $s \equiv j - r$; or
- (iii) $h \equiv -s$, $s \equiv r - s$ and $r \equiv j - s$.

These alternatives correspond to the three cases given in the statement of the theorem. Notice that each cancellation produces the factor -1 in case (i) and $+1$ in the other two cases, leading to the term $(-1)^n$ on the right side of (8). Thus one direction of the theorem is proved.

On the other hand, since the areas of the triangles are given by polynomials in the coordinates of the points involved, the product in the theorem can have a constant value only if the polynomials of the substituted product cancel. As we have seen, this happens only in the cases listed.

Remarks and exercises.

(1) As already mentioned, the theorem of Menelaus was generalized to n -laterals by Carnot, at the beginning of the 19th century. The generalized theorem of Ceva seems to be due to Poncelet [1821]. Both are given in many of the "college geometries" available at the present. However, rather surprisingly, there seems to be no mention in the literature of anything resembling the "selftransversality theorem" prior to Grünbaum & Shephard [1995].

(2) The "area principle" is a very convenient tool usable in the proofs of many results in which ratios of lengths of collinear segments are involved. It seems to have been "discovered" independently by many people (Shephard and I among them). According to

Baptist [1992], the "area principle" was used — without any special name or comment — already by Crelle [1816] in the proof of the triangle version of Ceva's theorem. It is also used as an essential ingredient in the remarkable book Chou, Gao & Zhang [1994], which was mentioned earlier, in Section 1.

(3) The theorem of Ceva and that of Menelaus are essentially equivalent in the sense that each can be deduced from the other quite easily. This is done in many of the standard texts. On the other hand, as we shall see in the next section, the theorem of Menelaus and its generalization are consequences of generalizations of Ceva's theorem, but not the other way around.

(4) Many other generalizations and analogues of Ceva's theorem are known. We shall discuss two of these later. Here is one version that generalizes the theorem given earlier, and can be proved completely analogously.

Let $P = \langle V_1, V_2, \dots, V_n \rangle$ be an n -acron, C a point, and k an integer with $1 \leq k < n/2$. For $i = 1, 2, \dots, n$ let W_i be the intersection point of the lines $\langle C, V_i \rangle$ and $\langle V_{i-k}, V_{i+k} \rangle$. Then

$$\prod_{i=1}^n \left[\frac{V_{i-k} W_i}{W_i V_{i+k}} \right] = 1.$$

(5) Euler [1780] gave several (rather complicated) proofs of the following two results, the first of which follows rather trivially from the area principle.

Let $M = \langle V_1, V_2, V_3 \rangle$ be a 3-lateral and let C be a point. For $i = 1, 2, 3$ let W_i be the intersection point of the lines $\langle C, V_i \rangle$ and $\langle V_{i-1}, V_{i+1} \rangle$. Then

$$\sum_{i=1}^3 \left[\frac{C W_i}{V_i W_i} \right] = 1,$$

and if C is inside the triangle $\langle V_1, V_2, V_3 \rangle$ then

$$\prod_{i=1}^3 \left[\frac{V_i C}{C W_i} \right] = 2 + \sum_{i=1}^3 \left[\frac{V_i C}{C W_i} \right].$$

It is interesting to note that while the first relation is rather well known, I have not seen the second anywhere except in Euler's writings. This second relation is really rather intriguing; I do not know any elegant proof for it. It is also of some interest to see what happens if the point C is not inside the triangle.

** Problem: Generalize either part of Euler's theorem to polyacrons or polygons..

References.

P. Baptist, Die Entdeckung der neueren Dreiecksgeometrie. BI Wissenschaftsverlag, Mannheim 1992.

L. N. M. Carnot, Géométrie de position. Duprat, Paris 1803.

S.-C. Chou, X.-S. Gao and J.-Z. Zhang, Machine Proofs in Geometry. Automated Production of Readable Proofs for Geometry Theorems. World Scientific, Singapore 1994.

A. L. Crelle, Über einige Eigenschaften des ebenen geradlinigen Dreiecks rücksichtlich dreier durch die Winkel-Spitzen gezogenen geraden Linien. Berlin 1816.

L. Euler, Geometrica et sphaerica quedam. Submitted to the Petersburg Academy in 1780, published in 1815, and in Opera Omnia, First Series, Vol. 26, pp. 344 - 358, Füssli, Lausanne 1953.

B. Grünbaum and G. C. Shephard, Ceva, Menelaus and the area principle. Math. Magazine 68(1995), 254 - 268.

J.-V. Poncelet, Traité des propriétés projectives des figures. Mallet-Bachelier, Paris 1821; 2nd ed. Gauthier-Villars, Paris 1865.

5. The general transversality theorem.

The next result simultaneously extends the Selftransversality Theorem and the theorems of Menelaus and Ceva to n -acrons in spaces of arbitrary dimension. For its formulation we need an extension of the notation and terminology introduced earlier.

Given two r -simplices $[U_0, \dots, U_r]$ and $[V_0, \dots, V_r]$ contained in the same r -flat (or in parallel r -flats) of the d -dimensional Euclidean or affine space, we denote by $\left[\frac{U_0 \dots U_r}{V_0 \dots V_r} \right]$ the quotient of the absolute values of the r -contents of the two simplices, prefixed by a $+$ or a $-$ sign according to whether the simplices are oriented in the same way or oppositely. This is clearly an generalization of the analogous symbols we used above, in cases $r = 1$ or 2 .

Before stating it formally, it seems appropriate to explain the idea of the new theorem. We start from an n -acron P and a (fixed) q -flat Q in d -space. Assume these and all other objects under discussion are in sufficiently general position so that all the intersections and quotients exist and behave as expected. To each r -flat R_i , determined by $r + 1$ points of P chosen in a particular way, we associate in a prescribed manner an s -flat S_i , where $s = d - q - r - 1$. Then the *transversal* $T_i = \text{aff}(Q \cup R_i)$, specified by the *anchor* Q and the flat R_i , meets S_i in a single point. This point, together with certain vertices of P , is used to determine two s -dimensional simplices. The theorem asserts that (under appropriate conditions), the circular product of the ratios of the s -dimensional contents of these simplices has a constant value which, moreover, equals $+1$ or -1 . The precise statement of the theorem is given below, after some additional notation has been introduced.

Let $P = (V_1, \dots, V_n)$ be an n -acron in d -space, where $1 \leq d \leq n - 1$. Let q, r, s be integers such that $-1 \leq q \leq d - 1$, $-1 \leq r \leq d - 1$, $1 \leq s \leq \min\{d, n - r - 2\}$ and $q + r + s + 1 = d$. Further let $A = (a_0, \dots, a_s)$ and $B = (b_0, \dots, b_r)$ be sequences of integers in $\{0, 1, \dots, n-1\}$ such that all the elements of $A \cup B$ are distinct modulo n . Let S_i denote the s -flat $\text{aff}(V_{i+a_0}, V_{i+a_1}, \dots, V_{i+a_s})$ and R_i the r -flat $\text{aff}(V_{i+b_0}, V_{i+b_1}, \dots, V_{i+b_r})$. Let Q be a q -flat such that, for each $i = 1, \dots, n$, the $(q + r + 1)$ -flat $T_i = \text{aff}(Q \cup R_i)$ spanned by Q and R_i meets the s -flat S_i in a single point Z_i which (by the assumed general position of the vertices) must be distinct from $V_{i+a_0}, V_{i+a_1}, \dots, V_{i+a_s}$. (If $q = -1$ or $r = -1$ then the corresponding flat Q or R is interpreted as being empty. Note that $q = r = -1$ is excluded by the assumptions on the parameters.) Now define

$$\rho(P; A, B, Q) = \prod_{i=1}^n \left[\frac{V_{i+a_0} V_{i+a_1} \cdots V_{i+a_{s-1}} Z_i}{V_{i+a_1} V_{i+a_2} \cdots V_{i+a_s} Z_i} \right] . \quad (*)$$

This is the circular product of ratios mentioned above. Conditions under which this product takes a fixed value independent of the particular n -acron P and flat Q chosen are given by the following result:

The Transversality Theorem

Given an n -acron P in A^d , a flat Q and sequences A and B of integers as specified above, then $\rho(P; A, B, Q)$ is a constant independent of P if and only if there exists an integer k such that, modulo n , the sequence

$$(a_0 + k, a_1 + k, \dots, a_{s-1} + k, b_0 + k, b_1 + k, \dots, b_r + k)$$

is a permutation π of the sequence

$$(a_1, a_2, \dots, a_s, b_0, b_1, \dots, b_r).$$

The value of the constant is given by $\rho(P; A, B, Q) = (e(\pi))^n$, where $e(\pi) = 1$ if π is an even permutation and $e(\pi) = -1$ if π is an odd permutation.

Before giving a proof of the Transversality Theorem we shall give a geometric interpretation of the condition stated in the theorem, and offer some explanatory comments. To do the former we use what we shall call AB -diagrams. Start with an n -acron N consisting of equidistant concyclic points, label the points of N by $0, 1, 2, \dots, n-1$ consecutively in a positive direction, and mark those that correspond to the integers a_i and b_i . (For easier visualization, the points of N can be considered as the vertices of a regular n -gon.) The points corresponding to a_0 and a_s are marked in such a way that they can be distinguished from those corresponding to a_1, \dots, a_{s-1} and b_0, \dots, b_r . Figure 5.1(a) shows an example with $n = 9$, $A = (0, 1, 2, 3)$ and $B = (4, 6, 8)$. The condition of the theorem holds if and only if the two (unordered) sets of points, corresponding to the integers $\{a_0, \dots, a_{s-1}, b_0, \dots, b_r\}$ and to $\{a_1, \dots, a_s, b_0, \dots, b_r\}$ are *directly congruent* (as unmarked sets); that is, one can be made to coincide with the other by a suitable rotation about the center of the n -acron N . For the example of Figure 5.1(a), Figure 5.1(b) shows the two sets of vertices, and it will be observed that the second set can be obtained from the first by a rotation through angle $4\pi/9$. Hence, in this case, the condition of the theorem holds.

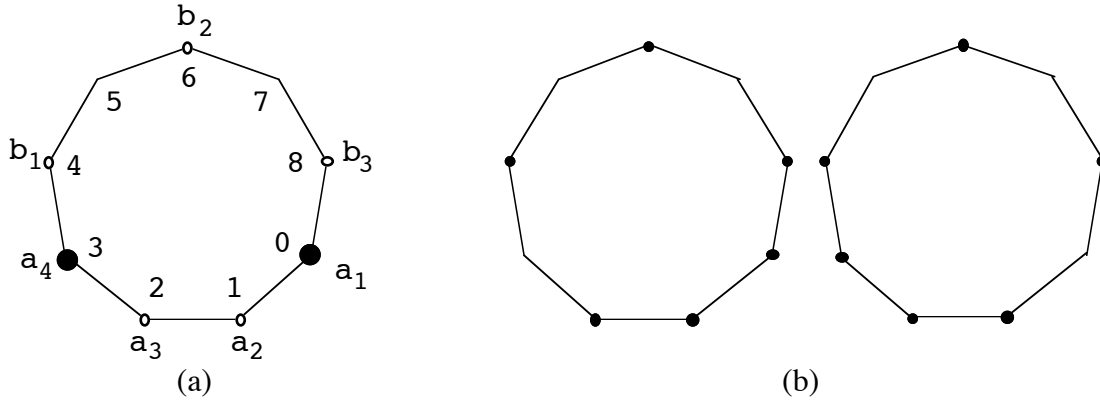

Figure 5.1. (a) An AB-diagram for $n = 9$, with $A = (0,1,2,3)$ and $B = (4,6,8)$. Here $s = 3$ and $r = 2$. Because the two sets of points marked in (b) are directly congruent, the sets A and B satisfy the condition of the Transversality Theorem.

Although the theorem is valid for all values of the parameters specified above (with appropriate choices of A and B), if $s = d$ the assertion becomes trivial in the following sense: The terms in the numerator and denominator of (*) are identical (apart from a possible permutation of the vertices defining the simplices), so complete cancellation can be carried out, yielding 1 or -1 at once.

This is illustrated in Figure 5.2(a), where $n = 5$, $d = 2$, $q = -1$, $r = 0$, $s = 2$, $A = (1, 2, 4)$ and $B = (3)$. Then the product $\rho(P; A, B, Q)$ involves quotients of the areas of triangles. Explicitly this is

$$\left[\frac{V_1 V_2 V_3}{V_2 V_4 V_3} \right] \cdot \left[\frac{V_2 V_3 V_4}{V_3 V_5 V_4} \right] \cdot \left[\frac{V_3 V_4 V_5}{V_4 V_1 V_5} \right] \cdot \left[\frac{V_4 V_5 V_1}{V_5 V_2 V_1} \right] \cdot \left[\frac{V_5 V_1 V_2}{V_1 V_3 V_2} \right]$$

and the cancellations become evident. On the other hand if all the parameters (as well as A and B) take the same values, except that $d = 3$ and $q = 0$, we arrive at the situation shown in Figure 5.2(b). Here the anchor Q is a fixed point and the line $\text{aff}(Q, V_3)$ meets the plane $\text{aff}(V_1, V_2, V_4)$ in Z_5 . The other points Z_i are determined by cyclically changing all the subscripts (mod 5). The theorem makes an assertion about the product $\rho(P; A, B, Q)$ of 5 terms of the form $\left[\frac{V_{i+1} V_{i+2} Z_i}{V_{i+2} V_{i+4} Z_i} \right]$ ($i = 0, 1, 2, 3, 4$) and clearly this result is far from trivial. In a similar way we obtain a non-trivial result (not illustrated) with the same values of the parameters (as well as A and B) except that $d = 4$, $q = 1$. Another trivial example, corresponding to $d = 2$, $q = 0$, $r = -1$, $s = 2$, $A = (1,2,3)$ and $B = \emptyset$, is illustrated in Figure 5.2(c).

In Table 1 we list all the nontrivial assertions of the theorem in the case $n = 5$. For each of the possible values of the parameters and of the dimension (in this case

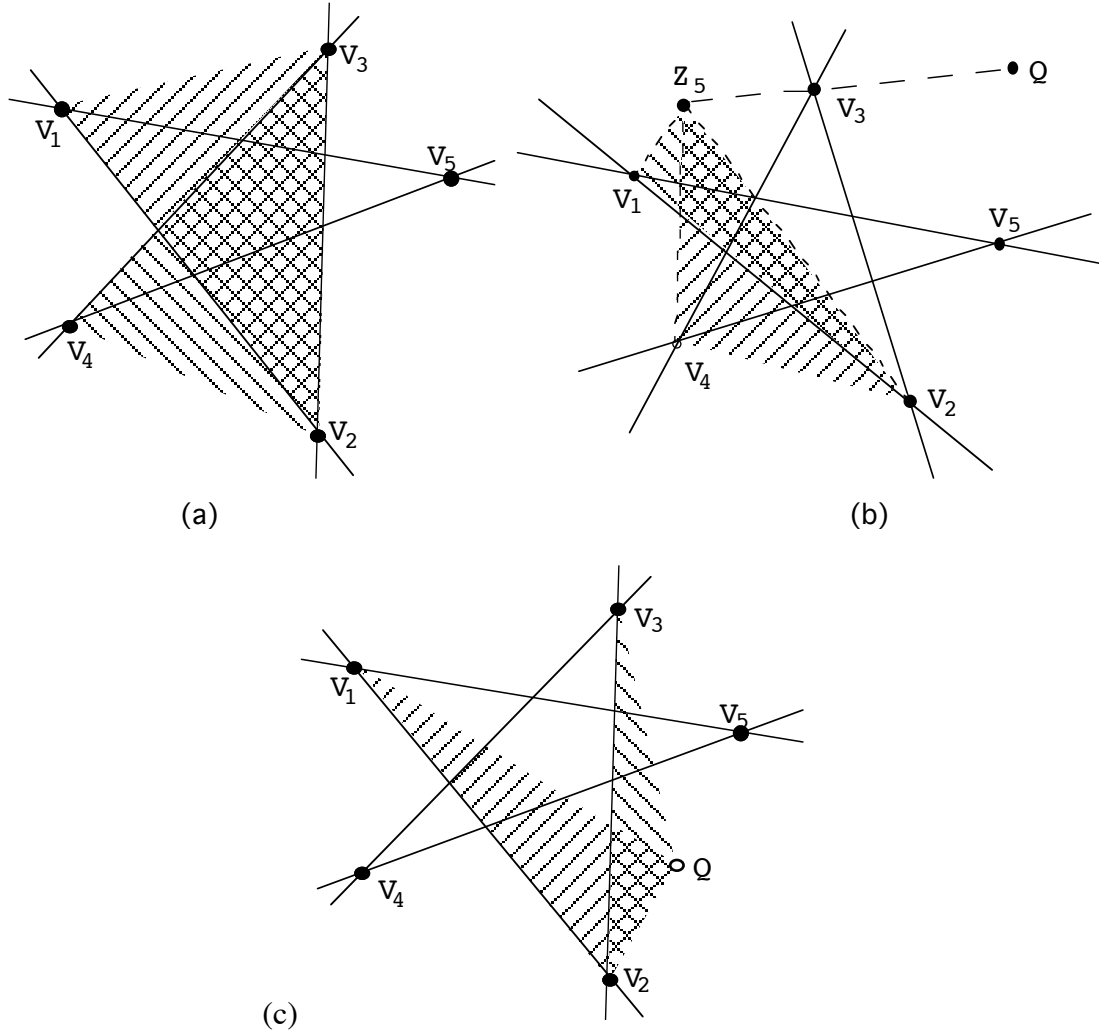

Figure 5.2. Three illustrations of the Transversality Theorem.

(a) The case $n = 5, d = 2, q = -1, r = 0, s = 2, A = (1, 2, 4)$ and $B = (3)$; hence $Z_i = V_{i+3}$. One of the ratios used in the compilation of $\rho(P; A, B, Q)$ is

$\left[\frac{V_1 V_2 V_3}{V_2 V_4 V_3} \right]$ which is the ratio of the areas of the two shaded triangles. The other four ratios are obtained by cyclic changes of the subscripts (mod 5). Since the areas of the triangles cancel, we refer to this case as trivial. This is entry #5 in Table 1.

(b) A non-trivial result in three dimensions (entry #25 in Table 1) in which the parameters (as well as A and B) take the same values as in (a) except that $q = 0, d = 3$. The line $\langle Q, V_3 \rangle = \text{aff}(Q, V_3)$ meets the plane $\text{aff}(V_1, V_2, V_4)$ in the point Z_5 . One of the ratios used in the computation of $\rho(P; A, B, Q)$ is

Error!

(c) If this figure is interpreted in $d = 2$ dimensions, with Q as a fixed point, the result is trivial. This is entry #9 in Table 1.

$d = 2, 3$ or 4) we can readily determine the permissible sets A and B using the AB-diagrams. It will be seen that, in the case of 5-acrons, the Transversality Theorem makes 34 non-trivial assertions. Some are classical theorems, but there are many which have not been formulated previously.

We now turn to the proof of the Transversality Theorem. Choose $q + 1$ points X_0, \dots, X_q in Q in such a way that the $n + q + 1$ points $V_1, \dots, V_n, X_0, \dots, X_q$ are in general position. Let the position vectors of points in \mathbb{R}^d be represented by the corresponding lower case letters, so that a point U_i has position vector u_i with components $(u_{i1}, u_{i2}, \dots, u_{id})$. In terms of determinants, the condition for $d + 1$ points U_0, U_1, \dots, U_d to lie in a hyperplane is

For $i = 1, \dots, n$ let H_i be the hyperplane spanned by the $(s - 1) + (r + 1) + (q + 1) = d$ points $V_{i+a_0}, \dots, V_{i+a_{s-1}}, V_{i+b_0}, \dots, V_{i+b_r}, X_0, \dots, X_q$, and suppose H_i meets the $(s - 1)$ -diagonal $\text{aff}(V_{i+a_0}, \dots, V_{i+a_{s-1}})$ in the point W_i . Because of the assumed generality of position of the points, W_i will be uniquely determined and distinct from V_{i+a_0} and V_{i+a_s} . Then $w_i = (1 - \lambda_i)v_{i+a_0} + \lambda_i v_{i+a_s}$ for some value of λ_i , and

$$\frac{\lambda_i}{\lambda_i - 1} = \left[\frac{V_{i+a_0} W_i}{V_{i+a_s} W_i} \right] = \left[\frac{V_{i+a_0} V_{i+a_1} \dots V_{i+a_{s-1}} Z_i}{V_{i+a_s} V_{i+a_1} \dots V_{i+a_{s-1}} Z_i} \right] = (-1)^{s-1} \left[\frac{V_{i+a_0} \dots V_{i+a_{s-1}} Z_i}{V_{i+a_1} \dots V_{i+a_s} Z_i} \right]. \quad (**)$$

The second equality holds since the simplices in the numerator and denominator of the last expression have the same base $[V_{i+a_1}, \dots, V_{i+a_{s-1}}, Z_i]$ and so their signed volumes are proportional to their heights, namely the signed lengths of the line segments $[V_{i+a_0}, W_i]$ and $[V_{i+a_s}, W_i]$. This is an extension of the "area principle" we used earlier; it could be called the "volume principle". (In the case $s = 1$, the second equality of (**)) is an identity since $Z_i = W_i$.)

Now, since W_i lies in the hyperplane H_i ,

$$0 = D(w_i, v_{i+a_1}, \dots, v_{i+a_{s-1}}, v_{i+b_0}, \dots, v_{i+b_r}, x_0, \dots, x_q)$$

$$\begin{aligned}
 &= D((1 - \lambda_i)v_{i+a_0} + \lambda_i v_{i+a_s}, v_{i+a_1}, \dots, v_{i+a_{s-1}}, v_{i+b_0}, \dots, v_{i+b_r}, x_0, \dots, x_q) \\
 &= (1 - \lambda_i) D(v_{i+a_0}, v_{i+a_1}, \dots, v_{i+a_{s-1}}, v_{i+b_0}, \dots, v_{i+b_r}, x_0, \dots, x_q) + \\
 &\quad \lambda_i D(v_{i+a_s}, v_{i+a_1}, \dots, v_{i+a_{s-1}}, v_{i+b_0}, \dots, v_{i+b_r}, x_0, \dots, x_q)
 \end{aligned}$$

and solving for $\lambda_i/(\lambda_i - 1)$ we obtain

$$\begin{aligned}
 \frac{\lambda_i}{\lambda_i - 1} &= \frac{D(v_{i+a_0}, v_{i+a_1}, \dots, v_{i+a_{s-1}}, v_{i+b_0}, \dots, v_{i+b_r}, x_0, \dots, x_q)}{D(v_{i+a_s}, v_{i+a_1}, \dots, v_{i+a_{s-1}}, v_{i+b_0}, \dots, v_{i+b_r}, x_0, \dots, x_q)} \\
 &= (-1)^{s-1} \frac{D(v_{i+a_0}, v_{i+a_1}, \dots, v_{i+a_{s-1}}, v_{i+b_0}, \dots, v_{i+b_r}, x_0, \dots, x_q)}{D(v_{i+a_1}, \dots, v_{i+a_{s-1}}, v_{i+a_s}, v_{i+b_0}, \dots, v_{i+b_r}, x_0, \dots, x_q)} \quad (***)
 \end{aligned}$$

Taking the product from $i = 1$ to $i = n$, we see that the determinants in the numerator are, up to a permutation π of columns, exactly those in the denominator if and only if condition given in the statement of the theorem holds. Moreover, this permutation of columns introduces n times the factor $e(\pi)$ into the value of the determinant. In all, we have, from (**) and (***),

$$\rho(P; A, B, Q) = \prod_{i=1}^n \left[\frac{V_{i+a_0} \cdots V_{i+a_{s-1}} Z_i}{V_{i+a_1} \cdots V_{i+a_s} Z_i} \right] = \prod_{i=1}^n \frac{(-1)^{s-1} \lambda_i}{\lambda_i - 1} = (e(\pi))^n$$

as claimed.

Comments and exercises.

(1) Devise a proof of Carnot's theorem (see page 2.1) by projecting L and all the points involved onto a line K perpendicular to L , the projection being along L . Formulate the result in \mathbf{E}^1 you are using in the proof. For $n = 5$, locate the 1-dimensional case among the entries in Table 1. If you find any discrepancies, explain them. Formulate the theorem of Menelaus and Carnot (formulated in Section 4) as a special case of the Transversality Theorem; which entry of Table 1 corresponds to Carnot's theorem for $n = 5$? Explain the geometric meaning of the first ten entries in Table 1.

- (2) Locate the generalized theorem of Ceva (from Section 4) as a special instance of the Transversality Theorem.
- (3) Explain the meaning of the transversality theorem for $s = 1$, $q = 0$, and $d > 2$.
- (4) Generalize the result of (1) above by showing that those cases of the Transversality Theorem in which $q > 0$ (and thus can be interpreted as generalizations of the theorem of Menelaus and Carnot) are simple consequences of the cases in which $q = 0$ (and thus correspond to Ceva's theorem). More geometrically, the assertion of the theorem for a given n -acton P with any given d and $q > 0$ can be reduced to the one for an n -acron P' with $d' = d - q$ and $q' = 0$ by projecting P along Q onto a d' -dimensional flat complementary to Q . As a consequence it follows that the only "independent" cases of the Transversality Theorem are the ones with $q = -1$ and $q = 0$.
- (5) Explain the meaning of cases 33 and 34 in Table 1.
- (6) Arrange a table analogous to Table 1, for $n = 4$. Explain the geometric meaning of all the entries.

Entry number	d	q	r	s	A	B	$e(\pi) = \rho$
1	1	-1	0	1	{1,2}	{4}	-1
2	1	-1	0	1	{1,3}	{2}	-1
3	1	0	-1	1	{1,2}	\emptyset	1
4	1	0	-1	1	{1,3}	\emptyset	1
5	2	-1	0	2	{1,2,4}	{3}	-1
6	2	-1	0	2	{1,3,2}	{5}	-1
7	2	-1	1	1	{1,2}	{3,5}	1
8	2	-1	1	1	{1,3}	{4,5}	1
9	2	0	-1	2	{1,2,3}	\emptyset	1
10	2	0	-1	2	{1,4,2}	\emptyset	1
11	2	0	0	1	{1,2}	{4}	-1
12	2	0	0	1	{1,3}	{2}	-1
13	2	1	-1	1	{1,2}	\emptyset	1
14	2	1	-1	1	{1,3}	\emptyset	1
15	3	-1	0	3	{1,2,3,4}	{5}	-1
16	3	-1	0	3	{1,2,4,3}	{5}	-1
17	3	-1	0	3	{1,2,4,5}	{3}	-1
18	3	-1	1	2	{1,2,3}	{4,5}	1
19	3	-1	1	2	{1,2,4}	{3,5}	1
20	3	-1	1	2	{1,4,2}	{3,5}	1
21	3	-1	2	1	{1,2}	{3,4,5}	-1
22	3	-1	2	1	{1,3}	{2,4,5}	-1
23	3	0	-1	3	{1,2,3,4}	\emptyset	1
24	3	0	-1	3	{1,3,5,2}	\emptyset	1
25	3	0	0	2	{1,2,4}	{3}	-1
26	3	0	0	2	{1,3,2}	{5}	-1
27	3	0	1	1	{1,2}	{3,5}	1
28	3	0	1	1	{1,3}	{4,5}	1
29	3	1	-1	2	{1,2,3}	\emptyset	1
30	3	1	-1	2	{1,4,2}	\emptyset	1
31	3	1	0	1	{1,2}	{4}	-1
32	3	1	0	1	{1,3}	{2}	-1
33	3	2	-1	1	{1,2}	\emptyset	1
34	3	2	-1	1	{1,3}	\emptyset	1

Table 1. The essentially different possibilities of the parameters d, q, r, s and sets A and B for which the Transversality Theorem is valid when $n = 5$. Since n is odd we have $e(\pi) = \rho$.

6. The theorems of Hoehn and Pratt-Kasapi

There is a great number of theorems that are related to the theorems of Ceva, Menelaus and other transversality theorems we have seen. For example, in many cases a circular product of various ratios has a constant value 1 or -1. In other cases there is a relation between several products or cross products. The precise results depend on the circumstances considered. In the present section and the next we shall provide examples of some of the possibilities. Throughout, we shall tacitly assume that the points in question are in sufficiently general position so that all the ratios, and all the intersection points, are well defined. Also, in order to avoid crowding, in all diagrams we shall replace the (unbounded) lines by the shortest segments which include all relevant points.

We begin with a pair of results in which certain lines determined by vertices of an n -acron P are used to obtain **two** new points on each side (or each diagonal of a given spread) of P , and use these points together with the vertices that determined the side (or diagonal) in creating the ratios whose circular product is considered. Since there are now four collinear points, various ratios can be considered. In fact two choices lead to interesting results. The prototype of these theorems have been found by Hoehn [1993]. In the notation of Figure 6.1, Hoehn's theorems are:

$$\left[\frac{V_1 W_1}{W_2 V_3} \right] \cdot \left[\frac{V_2 W_2}{W_3 V_4} \right] \cdot \left[\frac{V_3 W_3}{W_4 V_5} \right] \cdot \left[\frac{V_4 W_4}{W_5 V_1} \right] \cdot \left[\frac{V_5 W_5}{W_1 V_2} \right] = 1$$

and

$$\left[\frac{V_1 W_2}{W_1 V_3} \right] \cdot \left[\frac{V_2 W_3}{W_2 V_4} \right] \cdot \left[\frac{V_3 W_4}{W_3 V_5} \right] \cdot \left[\frac{V_4 W_5}{W_4 V_1} \right] \cdot \left[\frac{V_5 W_1}{W_5 V_2} \right] = 1.$$

As generalizations of Hoehn's results we have the following two theorems, which are illustrated for $n = 7$ in Figures 6.3, 6.4 and 6.5.

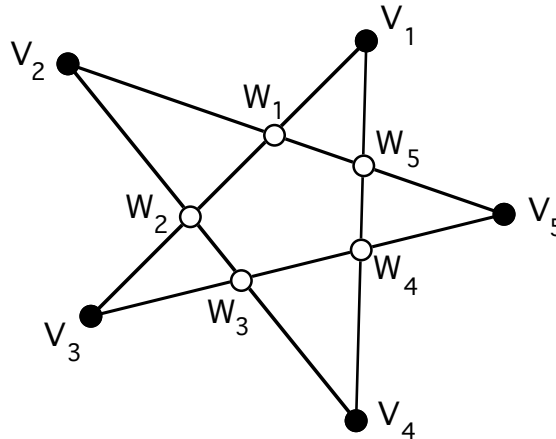

Figure 6.2. An illustration of Hoehn's theorems.

Hoehn's First Theorem. Let $P = (V_1, V_2, \dots, V_n)$ be an n -acron and let j be an integer such that $0, j, 2j, 3j, 4j$ are all distinct (mod n). For $i = 1, 2, \dots, n$ let W_i be the intersection point of the lines $\langle V_i, V_{i+2j} \rangle$ and $\langle V_{i-j}, V_{i+j} \rangle$. Then the points W_i and W_{i+j} lie on the line $\langle V_i, V_{i+2j} \rangle$ and

$$\prod_{i=1}^n \left[\frac{V_i W_i}{W_{i+j} V_{i+2j}} \right] = 1.$$

Hoehn's Second Theorem. Let $P = (V_1, V_2, \dots, V_n)$ be an n -acron and let k be an integer such that $0, k, 2k, 3k, 4k$ are all distinct (mod n). For $i = 1, 2, \dots, n$ let W_i be the intersection point of the lines $\langle V_i, V_{i+k} \rangle$ and $\langle V_{i-k}, V_{i-2k} \rangle$. Then the points W_i and W_{i+2k} lie on the line $\langle V_i, V_{i+k} \rangle$ and

$$\prod_{i=1}^n \left[\frac{V_i W_i}{W_{i+2k} V_{i+k}} \right] = 1.$$

Proof. The proof of Hoehn's First Theorem can be formulated as follows, using the area principle and the notation given in Figure 6.2. The four-parts symbols in the last two steps are oriented areas of quadrangles. We have

$$\begin{aligned} \left[\frac{V_i W_i}{W_{i+j} V_{i+2j}} \right] &= \left[\frac{V_i V_{i+2j}}{W_{i+j} V_{i+2j}} \right] \cdot \left[\frac{V_i W_i}{V_i V_{i+2j}} \right] = \\ \left[\frac{V_i W_{i+j} + W_{i+j} V_{i+2j}}{W_{i+j} V_{i+2j}} \right] &\cdot \left[\frac{V_i W_i}{V_i W_i + W_i V_{i+2j}} \right] = \\ \left[\frac{V_i V_{i+j} V_{i+3j} + V_{i+j} V_{i+2j} V_{i+3j}}{V_{i+j} V_{i+2j} V_{i+3j}} \right] &\cdot \left[\frac{V_{i-1} V_i V_{i+1}}{V_{i-1} V_i V_{i+1} + V_{i-1} V_{i+1} V_{i+2j}} \right] = \\ \left[\frac{V_i V_{i+j} V_{i+2j} V_{i+3j}}{V_{i+j} V_{i+2j} V_{i+3j}} \right] &\cdot \left[\frac{V_{i-1} V_i V_{i+1}}{V_{i-1} V_i V_{i+1} V_{i+2j}} \right] = \\ \left[\frac{V_{i-1} V_i V_{i+1}}{V_{i+j} V_{i+2j} V_{i+3j}} \right] &\cdot \left[\frac{V_i V_{i+j} V_{i+2j} V_{i+3j}}{V_{i-1} V_i V_{i+1} V_{i+2j}} \right]. \end{aligned}$$

Hence, in the circular product, all ratios will cancel, establishing the result. The proof of Hoehn's Second Theorem proceeds completely analogously.

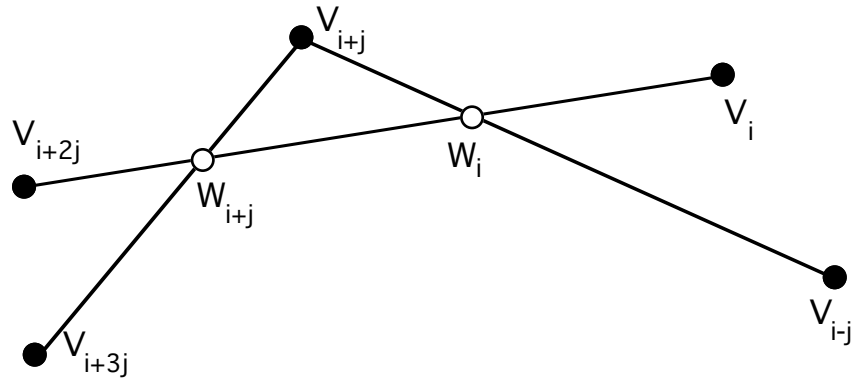

Figure 6.2. The notation used in the transformation of a typical ratio in the circular product appearing in Hoehn's First Theorem.

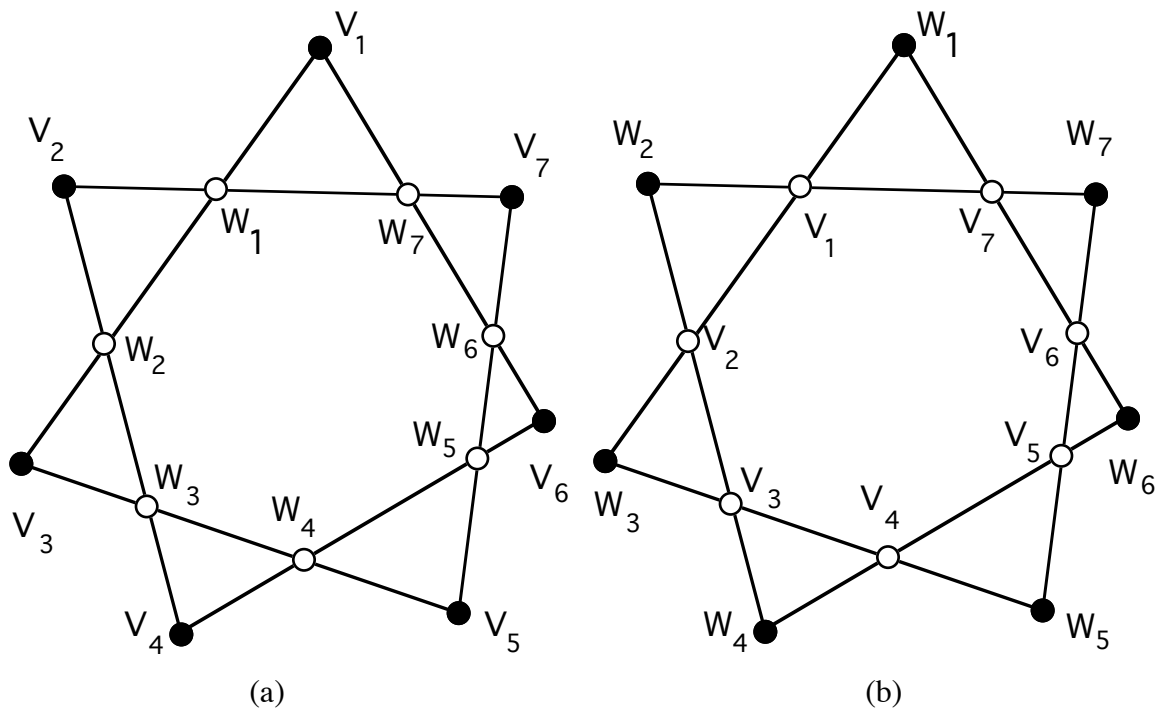

Figure 6.3. (a) Illustration of Hoehn's First Theorem for $n = 7, j = 1$. (b) Illustration of Hoehn's Second Theorem, with $n = 7, k = 1$.

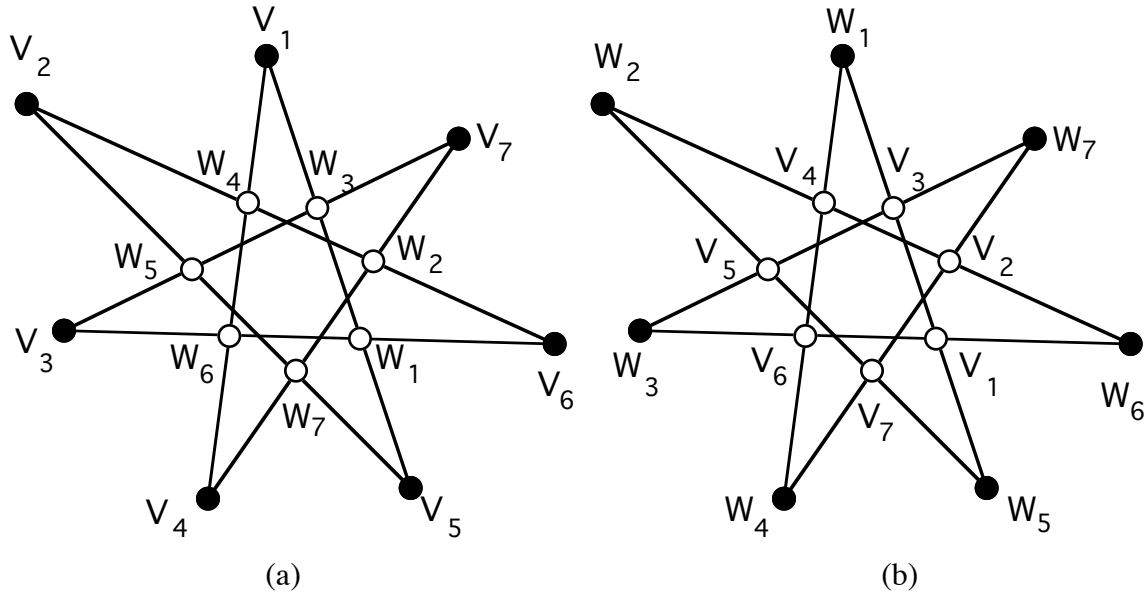

Figure 6.4. (a) Illustration of Hoehn's First Theorem for $n = 7$, $j = 2$. (b) Illustration of Hoehn's Second Theorem, with $n = 7$, $k = 2$.

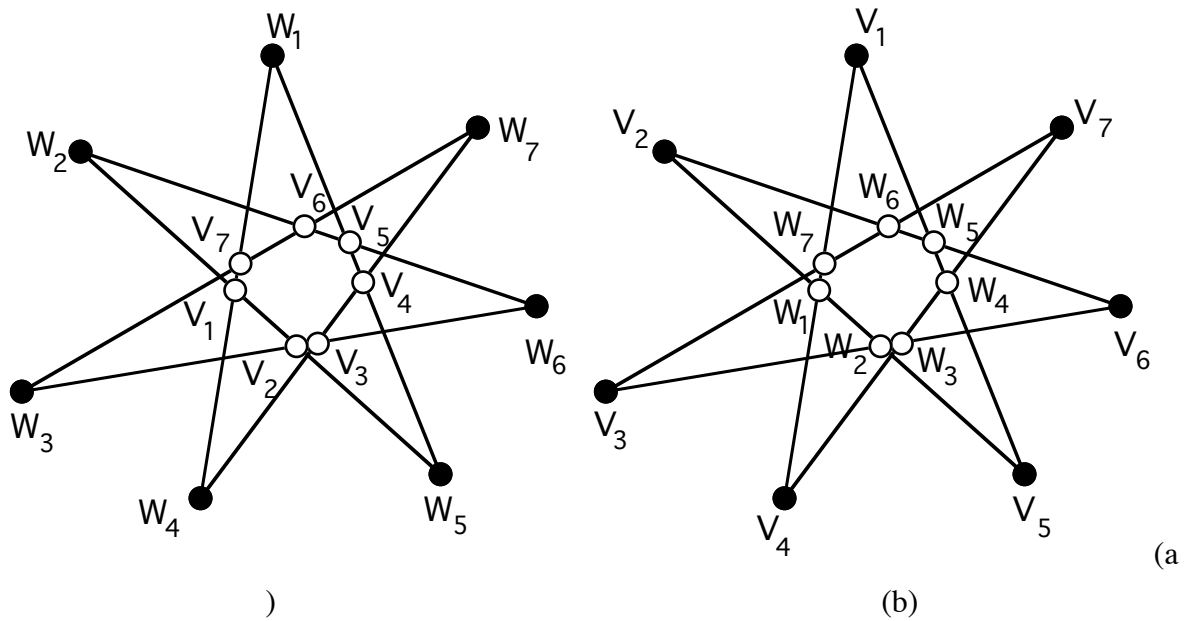

Figure 6.5. (a) Illustration of Hoehn's First Theorem for $n = 7$, $j = 3$. (b) Illustration of Hoehn's Second Theorem, with $n = 7$, $k = 3$.

The second topic we shall discuss in this section has as its prototype a result in Chou [1988], Example 81, where it is attributed to Pratt & Kasapi (see below for more information about this). The idea of the result can be derived from Chou's example, which deals with $n = 5$ and is shown in Figure 6.6; it is as follows. Given an n -acron $P = (V_1,$

V_2, \dots, V_n), and positive integers k and h with $k < n/2$, $h < n/2$, consider for each vertex V_i a line L_i through V_i , parallel to the diagonal $V_{i-k}V_{i+k}$. We determine on each line L_i two additional points, U_i as the intersection of L_i with L_{i-h} , and Z_i as the intersection of L_i with L_{i+h} . (Naturally, the set of U points is the same as the set of Z points, but it is simpler to give them two names, for ease of accounting).

Theorem of Pratt and Kasapi. The relation

$$\prod_{i=1}^n \left[\frac{U_i V_i}{V_i Z_i} \right] = 1.$$

holds if and only if $h \equiv \pm k$ or $h \equiv \pm 2k \pmod{n}$.

Since the cyclic product for any h is the same as for $-h$, the inequalities we assumed for h and k imply that there are precisely two choices of h for each k , except if $k = n/4$ or $k = n/3$, in which cases there is only the choice $h = k$.

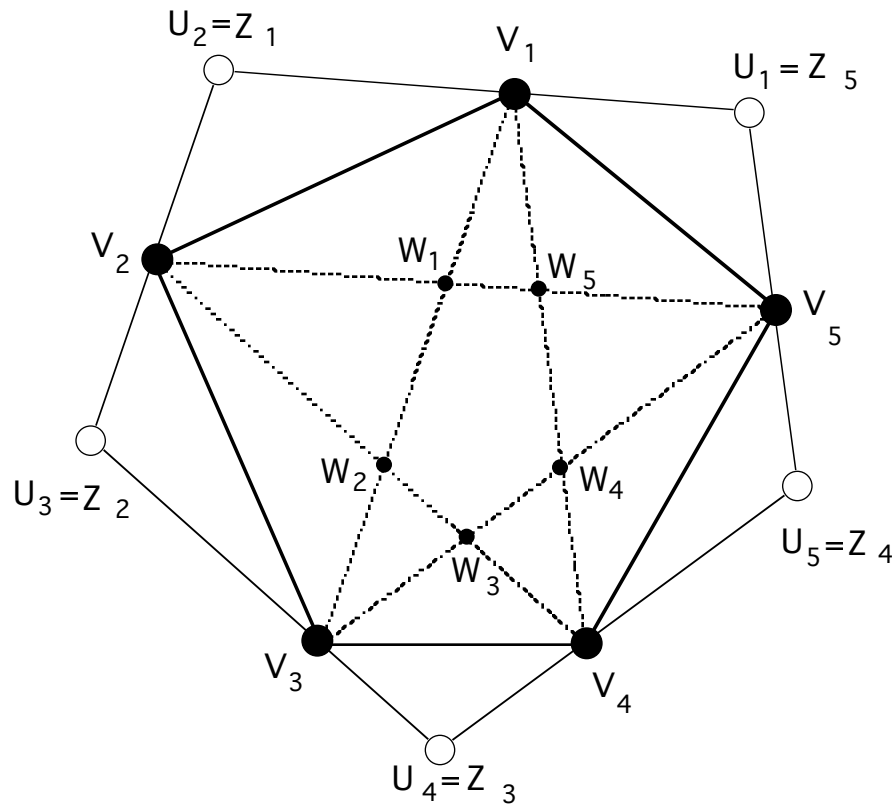

Figure 6.6. The illustration of the result attributed to Pratt and Kasapi by Chou [1988].

A proof can be devised along lines similar to those we have seen. It hinges on the fact that for $h = k$ we have

$$\left[\frac{U_i V_i}{V_i Z_i} \right] = \left[\frac{V_{i-2k} V_{i-k} V_i}{V_i V_{i+k} V_{i+2k}} \right] \cdot \left[\frac{V_{i-k} V_i V_{i+k} V_{i+2k}}{V_{i-2k} V_{i-k} V_i V_{i+k}} \right],$$

hence in the cyclic product all parts cancel and the product equals 1, while for $h = 2k$ we similarly have

$$\left[\frac{U_i V_i}{V_i Z_i} \right] = \left[\frac{V_{i-k} V_{i+k} V_{i+3k}}{V_{i-3k} V_{i-k} V_{i+k}} \right] \cdot \left[\frac{V_{i-3k} V_{i-2k} V_{i-k} V_i}{V_i V_{i+k} V_{i+2k} V_{i+3k}} \right],$$

so the product is again 1.

Remarks and exercises.

(1) Hoehn [1993] established his theorems for pentagram-like pentagons using repeated applications of the Menelaus-Carnot theorem. This motivated me to experimentally investigate whether the restriction to pentagrammatic polygons, and to pentagons in general, was necessary. As it turned out it is not, and the general case presented above appears in Grünbaum & Shephard [1995]; the formulation there is less streamlined. Another proof (also formulated for pentagons) of Hoehn's first theorem, and of some additional relations, is given by Pinkernell [1996]. Without mentioning Hoehn's second theorem, Pinkernell calls Hoehn's first theorem the Theorem of Pratt-Kassapi. Although a glance at Figures 6.1 and 6.6 shows that these two results are easily derived from each other (since, in Figure 6.6, $V_i W_i$ is a translate of $Z_i V_{i+1}$, and $W_i V_{i+1}$ is a translate of $V_i U_{i+1}$), this renaming is not justified since the two formulations are quite different, and only Hoehn's leads to a second theorem.

(2) The roots of the assignment of the name Pratt-Kasapi to the result mentioned above is quite interesting. The theorem (for $n = 5$) appears for the first time in Chou [1988], as Example 81, in a list of more than 500 geometric results proved by computer with a program Chou developed. Chou calls the result of Exercise 81 the Theorem of Pratt-Kasapi, but without any details as to the reason for the name. When I wrote to him asking about it, he kindly supplied the following information:

The history of Pratt-Kassapi is as follows. Professor Vaughen Pratt of Stanford University mentioned this to me when he visited UT Austin in 1984. The theorem is actually valid for any $n \geq 3$. He wanted the theorem for his conic spline problem:

Given n points on a plane, we need to join these points by a closed curve. If the curve joining the two adjacent points is cubic, then it can be [chosen to be] smooth in the sense that at each point the two cubic curves have the same tangent and curvature. The question was: can we do the same with conics? The practical value of the problem is that computation of [the] cubic curve is much [more] expensive.

If we need the tangents to be in certain directions, then for the conic case it cannot be arbitrary. But we may choose good directions. One heuristic is that the direction passing through A_i is parallel to $A_{i-1}A_{i+1}$. In order to justify that the curvatures [are also] the same at each point, we need to prove Pratt's conjecture for $n > 3$. Pratt reduced the general case to the case when $n = 5$. But he was unable to prove the case when $n = 5$ at that time. He asked me whether my prover [the computer program] could prove it. I proved the theorem the same day when he asked me and sent him an e-mail. Then he replied to me that Kassapi, an undergraduate at Waterloo, had already proved that two weeks before."

I do not know which of the two spellings — Kasapi or Kassapi — is correct, nor do I know that persons full name (or anything else).

The Pratt-Kasapi theorem appears also in Chou-Gao-Zhang [1994], as Example 2.66. Example 2.65 contains the two Hoehn theorems for pentagrams, with the remark that one of them "is equivalent to the Pratt-Kasapi result". Beyond this, in Theorems 2.67 and 2.68, Chou-Gao-Zhang prove results that (up to formulation) coincide with the Hoehn theorems as given above. Strangely, although they cite a preliminary version (from 1993) of Grünbaum & Shephard [1995], written at a time at which only numerical evidence was available, they do not mention Hoehn at all.

(3) In many cases it is possible to obtain a better understanding of the results about circular products of appropriate ratios by considering the relations that arise in cases in which the products are different from ± 1 . Illustrate to yourself the various situations that arise, and find proofs of the results stated in the following lines.

We need the notation illustrated by the 7-lateral in Figure 6.7; to avoid clutter, only selected points and lines are labelled in this diagrams Let $P = [V_1, V_2, \dots, V_n]$ be a given n -lateral, and let d and j be arbitrary integers satisfying $1 \leq d \leq n/2$, $1 \leq j \leq n/2$, and $j \neq d$. For $i = 1, 2, \dots, n$, we denote by $L(d, i)$ the line determined by V_i and V_{i+d} , and by $W_{d, j, i}$ be the intersection point of the lines $L(d, i)$ and $L(d, i+j)$. Let

$$T(n,d,j) = \prod_{i=1}^n \left[\frac{V_i W_{d,j,i}}{W_{d,j,i} V_{i+j+d}} \right] \quad \text{and} \quad S(n,d,j) = \prod_{i=1}^n \left[\frac{V_{i+j} W_{d,j,i}}{W_{d,j,i} V_{i+d}} \right] .$$

Hoehn's original results are that $S(5,2,1) = T(5,2,1) = 1$ provided P is a convex pentagon.

If $1 \leq j < d \leq n/2$, we shall say that the triplet (n,d,j) is of type $N(r)$, where r is one of $1,2,3,4,5,6,7$, depending on which of the additional conditions indicated below it satisfies:

$$\begin{array}{ll} N(1): & n < d + 2j; & N(2): & n = d + 2j; \\ N(3): & d + 2j < n < 2d + j; & N(4): & n = 2d + j; \\ N(5): & 2d + j < n < 2d + 2j; & N(6): & n = 2d + 2j; \\ N(7): & 2d + 2j < n. \end{array}$$

The results in question are:

$$(i) \quad \text{If } 1 \leq d \leq \left\lfloor \frac{n}{2} \right\rfloor \text{ and } 1 \leq j \leq \left\lfloor \frac{n}{2} \right\rfloor, \text{ then}$$

$$S(n,d,j) = S(n,j,d) \text{ and } T(n,d,j) = \frac{1}{T(n,j,d)} ;$$

hence from now on we shall limit the formulation to the case in which $1 \leq j < d \leq \left\lfloor \frac{n}{2} \right\rfloor$.

$$(ii) \quad S(n,d,j) = \frac{1}{S(n,d,d-j)} ; \text{ hence, if } d = 2j \text{ then } S(n,2j,j) = 1.$$

(iii) If (n,d,j) is of type $N(1)$ then $(n,d,n-d-j)$ is of type $N(3)$ and $(n,j,n-d-j)$ is of type $N(5)$; moreover, these mappings from $N(1)$ are onto $N(3)$ and onto $N(5)$. For (n,d,j) of type $N(1)$ we have

$$T(n,d,j) = T(n,j,n-d-j) = \frac{1}{T(n,d,n-d-j)} .$$

$$(iv) \quad \text{If } (n,d,j) \text{ is of type } N(2) \text{ or } N(4) \text{ then } T(n,d,j) = 1.$$

$$(v) \quad \text{If } (n,d,j) \text{ is of type } N(6) \text{ then}$$

$$T(n,d,j) = \frac{1}{T(n,d+j,j)} = T(n,d+j,d) = S(n,d+j,j) = \frac{1}{S(n,d+j,d)} .$$

$$(vi) \quad \text{If } (n,d,j) \text{ is of type } N(7) \text{ then}$$

$$T(n,d,j) = S(n,d+j,j) = \frac{1}{S(n,d+j,d)} .$$

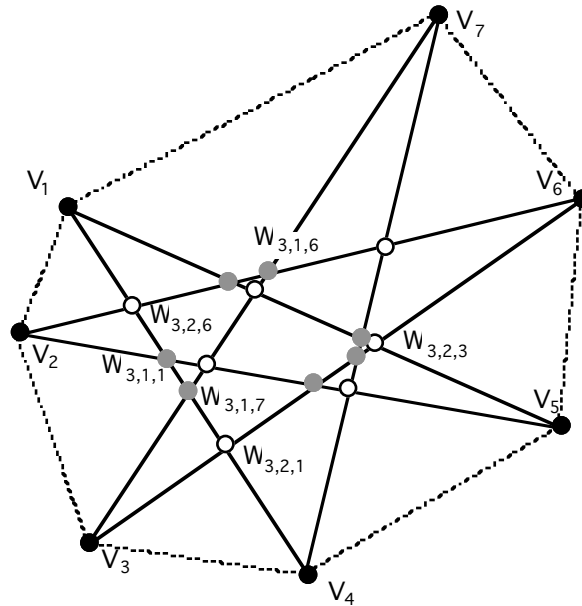

Figure 6.7. An illustration of the notation used for the result in (3) above.

References.

S.-C. Chou, *Mechanical Geometry Theorem Proving*. Reidel, Dordrecht 1988.

S.-C. Chou, X.-S. Gao and J.-Z. Zhang, *Machine Proofs in Geometry. Automated Production of Readable Proofs for Geometry Theorems*. World Scientific, Singapore 1994.

B. Grünbaum and G. C. Shephard, Ceva, Menelaus and the area principle. *Math. Magazine* 68(1995), 254 - 268.

L. Hoehn, A Menelaus-type theorem for the pentagram. *Math. Magazine* 66(1993), 121 - 123.

G. M. Pinkernell, Identities on point-line figure in the Euclidean plane. *Math. Magazine* 69(1996), 377 - 382.

Addendum to Section 6.

Asa Packer remarked to me at the end of class, and presented in detail during the next class, a much simpler way to prove the Hoehn theorems, and probably many other facts as well. The method is very simple once one has had the idea that, in reaching for the goal of complete cancellation, one need not restrict attention to the vertices of the n -acron; other suitable points may be used as well. Somehow, we never had that idea. Here goes Asa's proof.

For Hoehn's first theorem we have (see Figure 6.2)

$$\prod_{i=1}^n \left[\frac{V_i W_i}{W_{i+j} V_{i+2j}} \right] = \prod_{i=1}^n \left[\frac{V_i W_i V_{i+j}}{W_{i+j} V_{i+2j} V_{i+j}} \right] = 1,$$

since the triangles in the second part have the same altitudes and since the factors in the second part obviously cancel. Similarly, for Hoehn's second theorem

$$\prod_{i=1}^n \left[\frac{V_i W_i}{W_{i+2k} V_{i+k}} \right] = \prod_{i=1}^n \left[\frac{V_i W_i W_{i+1}}{W_{i+2k} V_{i+k} W_{i+1}} \right] = 1.$$

It would be interesting to investigate whether the relations on page 6.8 can be established in a simple way using Asa's method, and also to check its applicability to other questions.

7. Still more Ceva-type theorems.

We begin with the following simple-minded question: What happens if in the Generalized Theorem of Ceva (from page 4.1), we replace the sides of the n -lateral $M = \langle V_1, V_2, \dots, V_n \rangle$ by some of the other lines determined by the n -acron $P = (V_1, V_2, \dots, V_n)$? The answer is as follows:

The Complete Ceva Theorem. Let n, j, k be integers with $n \geq 3$, and let Q be a given point and $P = (V_1, V_2, \dots, V_n)$ an n -acron. We denote by W_i the intersection point of the lines $\langle V_i, Q \rangle$ and $\langle V_{i-j}, V_{i+k} \rangle$ and put

$$C(n; j, k) = \prod_{i=1}^n \left[\frac{V_{i+k} W_i}{W_i V_{i-j}} \right] = 1 .$$

Then

(a) $C(n; j, k) = (-1)^n C(n; n-j, k) = (-1)^n C(n; j, n-k) = C(n; n-j, n-k)$

and

(b) $C(n; j, j) = C(n; j, k) \cdot C(n; k, j) = C(n; j, k) \cdot C(n; k, m) \cdot C(n; m, j) = 1.$

Moreover, all other relations between circular ratio products can be derived from the relations in (a) and (b).

Note that the first part of (b) implies the Generalized Ceva Theorem of Section 4. The proofs of all parts of assertions in (a) and (b) are straightforward, either from the definitions or by using the area principle; hence we do not present them here. The one novel aspect in the theorem is the claim that the relations in (a) and (b) are essentially the only ones. This can be established by the following argument. Let P be the n -acron with $V_i = (x_i, -1)$ for $1 \leq i < n$, $V_n = (-x, 1)$, and $Q = (0, 0)$, illustrated in Figure 7.1. Then an easy calculation shows that

$$C(n; j, k) = \frac{c_k(x-x_k)(x-x_{n-k})}{c_j(x-x_j)(x-x_{n-j})} ,$$

where c_k and c_j are constants, independent of the variables x and the x_i 's. Since these variables are independent of each other, a cancellation of the fractions can occur only if exactly the same expressions occur in the numerators and denominators. But expressions of this kind involving four or more values of the subscripts can be simplified using the relations in (a) and (b). This completes the proof.

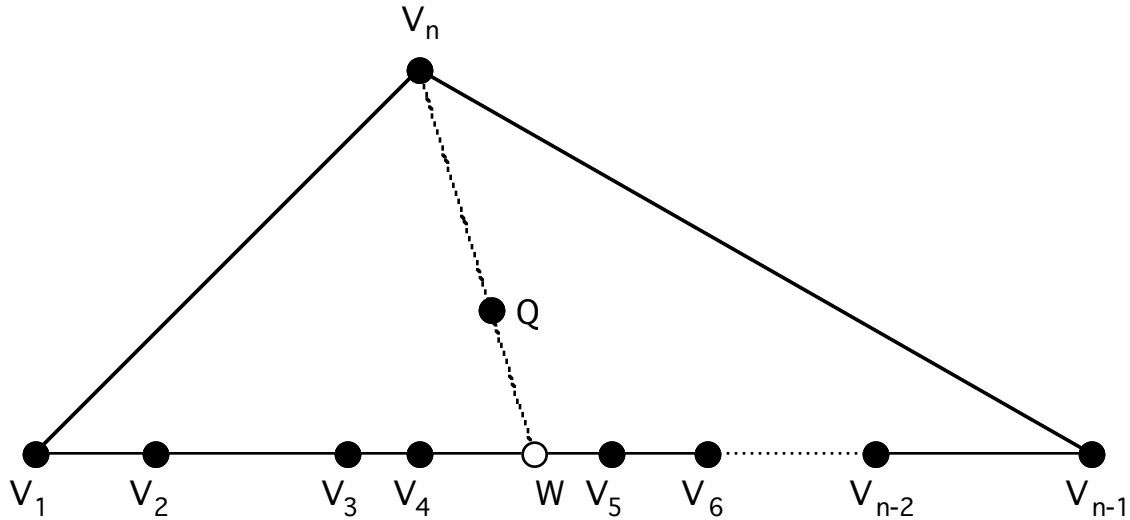

Figure 7.1. An example of an n -acron used in the proof of the Complete Ceva Theorem.

In a slightly different spirit, there is another theorem that reminds one of Ceva's theorem. Given a point C , for $i = 1, 2, \dots, n$, a point W_i on a side (or diagonal) $\langle V_i, V_{i+k} \rangle$ of a multilateral $M = \langle V_1, V_2, \dots, V_n \rangle$ is obtained as the intersection of $\langle V_i, V_{i+k} \rangle$ with the line $\langle C, Z_i \rangle$, where Z_i is the intersection point of two suitably chosen sides (or diagonals) of M . Specifically, we have

A Ceva variant. With the notation just explained,

$$\prod_{i=1}^n \left[\frac{V_i W_i}{W_i V_{i+k}} \right] = 1$$

provided $0, k, 2k, 3k$ are all distinct mod n , and either

(a) $Z_i = \langle V_i, V_{i-k} \rangle \cap \langle V_{i+k}, V_{i+2k} \rangle$

or

(b) $Z_i = \langle V_i, V_{i+2k} \rangle \cap \langle V_{i+k}, V_{i-k} \rangle$.

The two cases are illustrated by the examples in Figures 7.2 and 7.3.

Since the proofs are completely analogous to the ones we have seen, we do not give them. They appear in "A new Ceva-type theorem" by Shephard and myself, in the *Mathematical Gazette* 80(1996), 492 - 500.

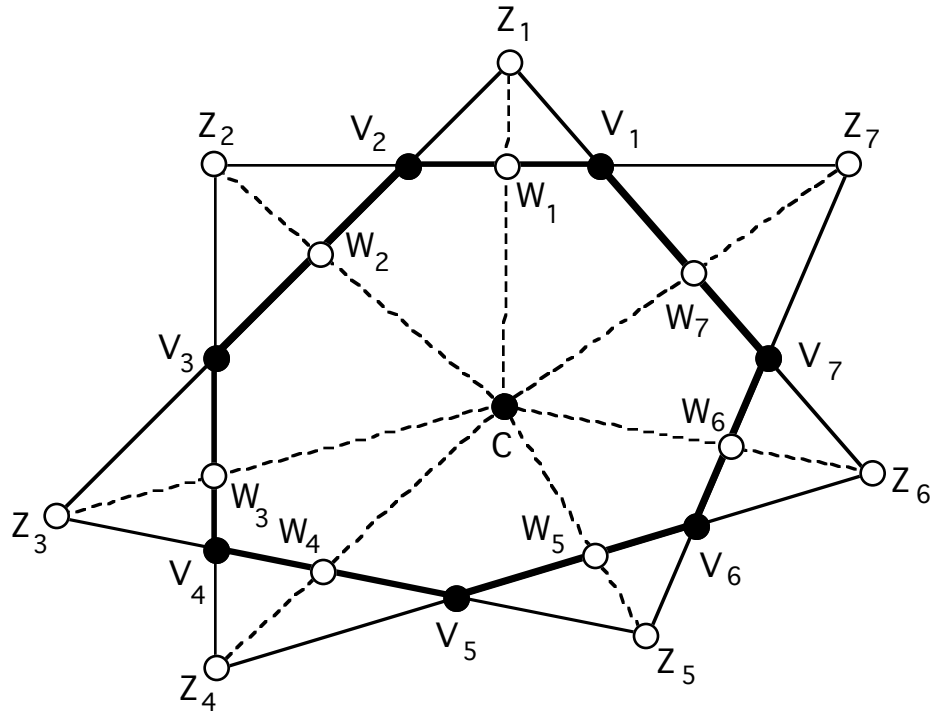

Figure 7.2. An illustration of the case (a) of the Ceva variant theorem, with $n = 7$ and $k = 1$.

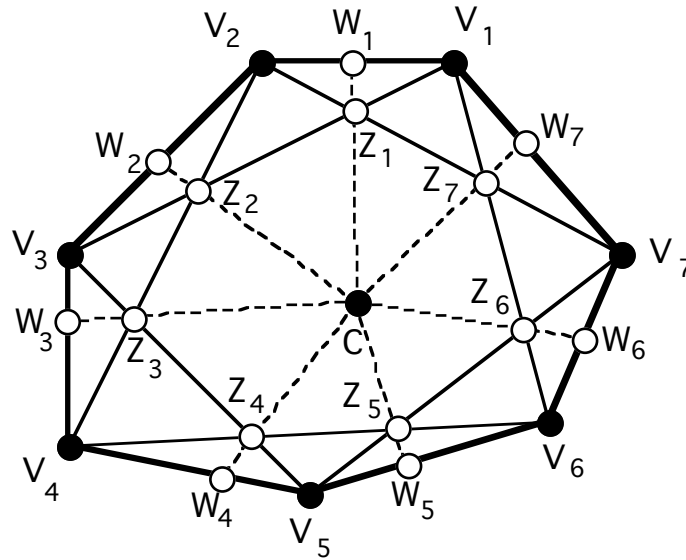

Figure 7.23. An illustration of the case (b) of the Ceva variant theorem, with $n = 7$ and $k = 1$.

8. Circular products of ratios involving circles.

There are many results of the same nature as the theorems of Ceva, Menelaus and other transversality theorems we have seen, but which deal with ratios of segments determined by circles on polyacrons. In the present section we shall discuss some of the possibilities.

One result deals with situations in which a family of circles leads to a family of tangents, whose intersections with lines of the polyacron yield the ratios whose product is constant. More precisely, we have the following.

Theorem 8.1. Given n -acron P with vertices V_j , where $j = 1, 2, \dots, n$; let C_j be the circumcircle of V_{j-1}, V_j, V_{j+1} , and let W_j be the intersection of the line V_{j-1}, V_{j+1} with the tangent to C_j at V_j . Then

$$\prod_{1 \leq j \leq n} \left[\frac{W_j V_{j-1}}{V_{j+1} W_j} \right] = (-1)^n.$$

This result is illustrated in Figure 8.1.

Proof. The proof is easy; see Figure 8.2. Consider one triplet of consecutive vertices, say ABC , its circumcircle, and the tangent to the circumcircle at B . The tangent intersects the line AC at W , and we wish to find a useful expression for WA/CW . Denote by A^* and C^* the perpendicular projections of A and C onto the tangent. Then

$$\begin{aligned} WA/WC &= AA^*/CC^* = AB \sin(\angle ABA^*) / CB \sin(\angle CBC^*) = \\ &= AB \cos(\angle ABO) / BC \cos(\angle CBO) = AB BO \cos(\angle ABO) / BC BO \cos(\angle CBO) = \\ &= (AB^2 + OB^2 - OA^2) / (CB^2 + OB^2 - OC^2) = AB^2 / CB^2. \end{aligned}$$

Therefore $\prod_{1 \leq j \leq n} \left[\frac{W_j V_{j-1}}{V_{j+1} W_j} \right] =$
 $\prod_{1 \leq j \leq n} (-1)^n (V_{j-1} V_j)^2 / (V_{j+1} V_j)^2 = (-1)^n.$ ~

As could be expected, there are other results of this nature, in which part of the points determining the circles are fixed. For example, we have:

Theorem 8.2. Given n -acron P with vertices V_j , where $j = 1, 2, \dots, n$, and a fixed point Q ; let C_j be the circumcircle of Q, V_j, V_{j+k} , and let W_j be the intersection of the line V_j, V_{j+k} with the tangent to C_j at Q . Then

$$\prod_{1 \leq j \leq n} \left[\frac{W_j V_j}{V_{j+k} W_j} \right] = (-1)^n.$$

The proof of Theorem 8.2 is a trivial modification of the proof of Theorem 8.1.

A different variant of such results is obtained if tangents to a circle through three vertices of an n -acron are used to generate a new n -acron, circumscribed to the starting one. The products of the ratios in which the old vertices divide the new vertices on each side are then computed. The result is:

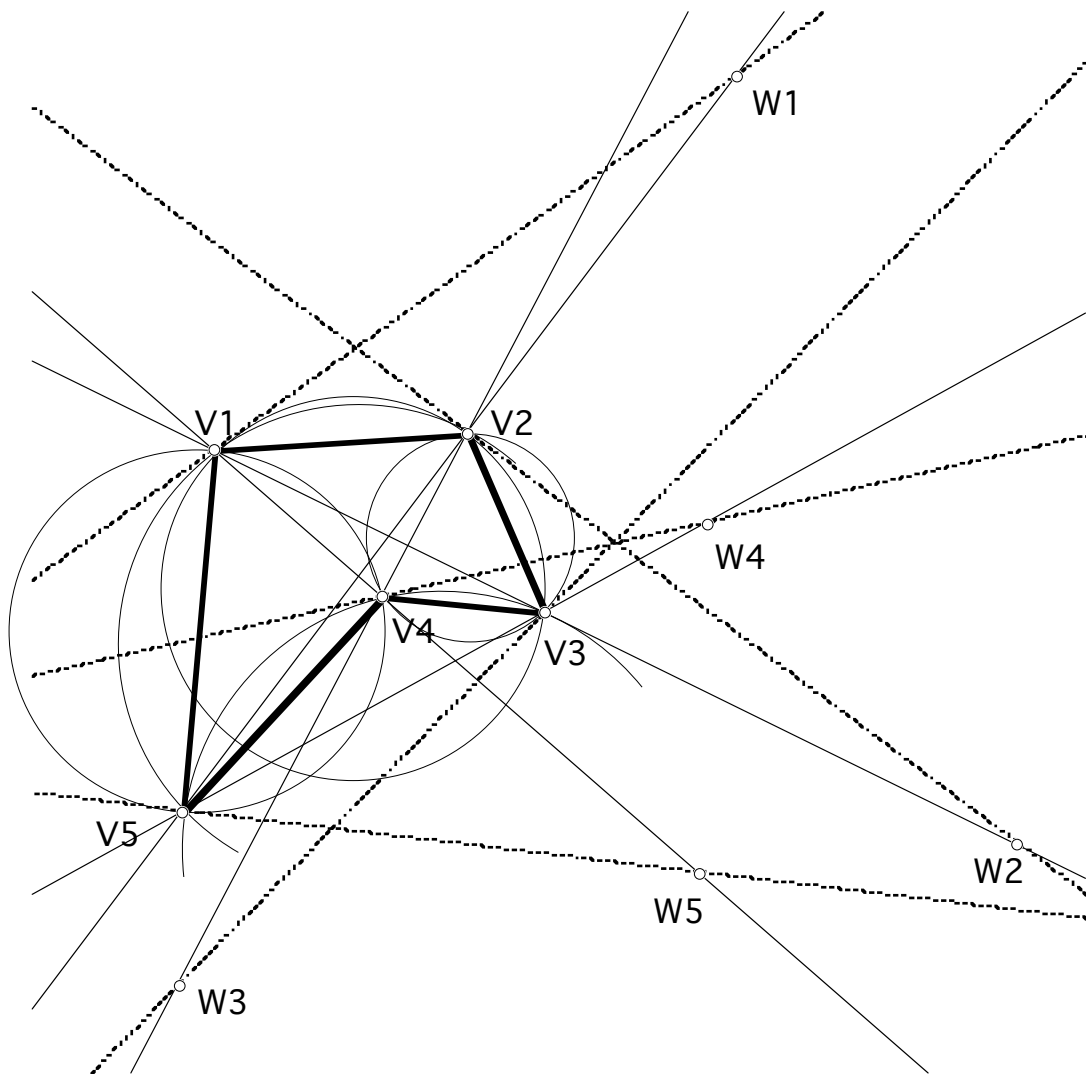

Figure 8.1. An illustration of Theorem 8.1, for $n = 5$.

Theorem 8.4. Given n -acron P with vertices V_j , where $j = 1, 2, \dots, n$; let T_j an arbitrary line through V_j , let W_j be the intersection of the lines $\langle V_{j-1}, V_{j+1} \rangle$ with T_j , and let Z_j be the intersection of T_j with T_{j+1} . Then

$$\prod_{1 \leq j \leq n} \left[\frac{V_{j-1} W_j}{V_{j+1} W_j} \right] \left[\frac{V_j Z_{j-1}}{Z_j V_j} \right] = 1$$

This is illustrated in Figure 8.3 for the case $n = 5$.

Theorem 8.4 was also first verified experimentally, and then confirmed by (straightforward, but messy) algebraic calculations. So far I have found no elegant proof.

A variant of Theorem 8.2 results if instead of circles we use arbitrary conic sections (quadratic polynomials). A conic section needs five points to be determined, and we have the following:

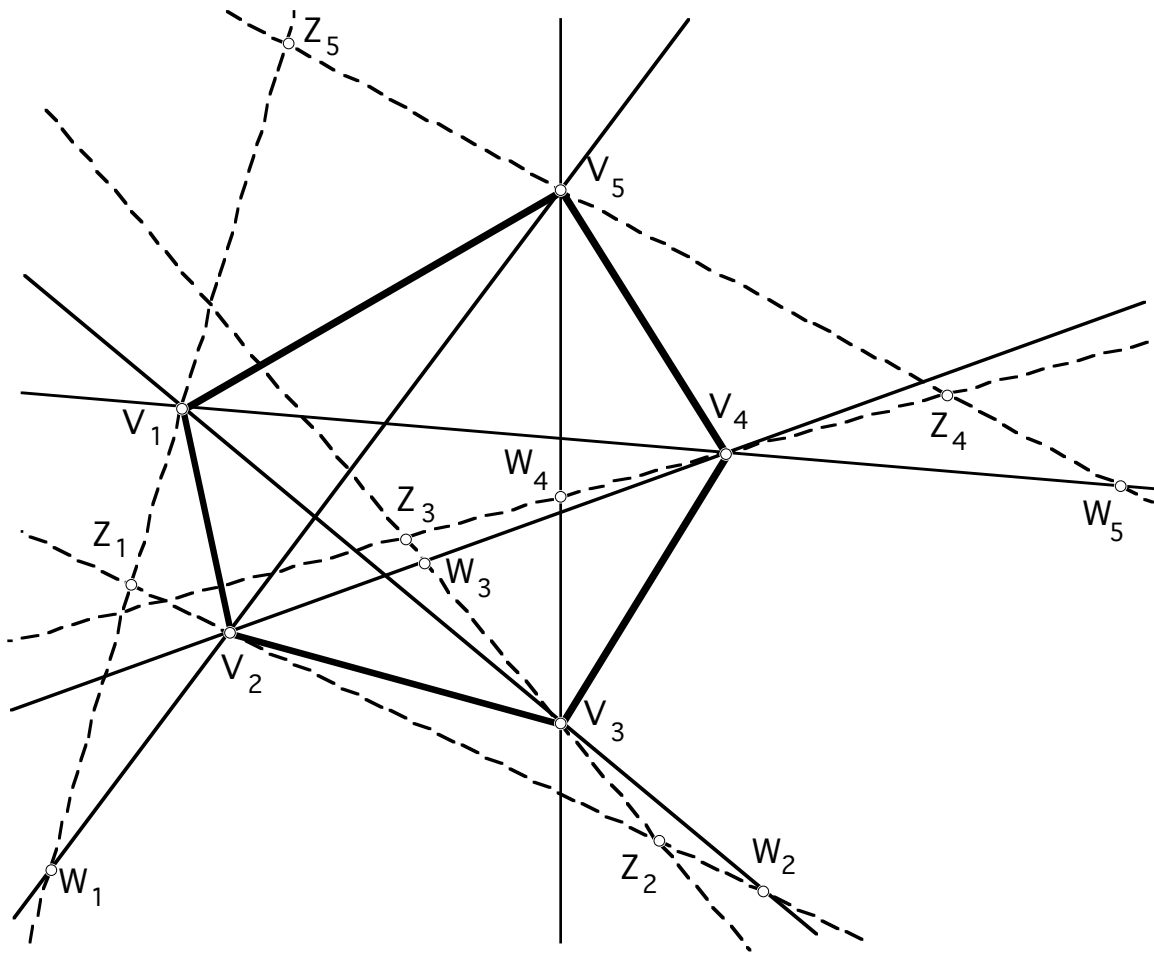

Figure 8.3. An illustration for $n = 5$ of Theorem 8.4.

Theorem 8.5. Given n -acron P , $n \geq 4$, with vertices V_j , where $j = 1, 2, \dots, n$, and a fixed point Q ; let C_j be the unique conic section determined by $Q, V_j, V_{j+k}, V_{j+2k}, V_{j+3k}$, and let W_j be the intersection of the line V_j, V_{j+3k} with the tangent to C_j at Q . Then

$$\prod_{1 \leq j \leq n} \left[\frac{W_j V_j}{V_{j+3k} W_j} \right] = (-1)^n$$

for all $k = 1, 2, \dots, [(n-1)/2]$ except $k = n/3$ if n is a multiple of 3.

(Recall that all subscripts are to be taken $(\text{mod } n)$.)

This result was also verified numerically; it should be provable by algebra (I did not have the patience), but it would be most appealing if an elegant proof were found.

Remarks and exercises.

(1) Theorems 8.1 and 8.3 remain valid for a variety of 3-parameter families of curves instead of circles. For example, one can take parabolas with equations of the form $ax^2 + bx + cy + d = 0$, or ellipses or hyperbolas $a(x^2 + 3y^2) + bx + cy + d = 0$, or $axy + bx + cy + d = 0$, or $a(x^2 - 5y^2) + bx + c + d = 0$, or $a/(x+3y) + bx + c + d = 0$, etc. All these have been confirmed numerically; formal proofs should be straightforward, but elegant proofs may be hard to find.

(2) Theorem 8.2 has even more far-reaching generalizations. It remains valid if the circles are replaced by any 3-parameter family of curves given by equations of the type $af(x,y) + bx + cy + d = 0$, where $f(x,y)$ is any differentiable function. This has been confirmed numerically with a wide selection of families; it would be rather interesting to find a formal argument.

(3) I have seen none of the result of this section in the literature, except that the case $n = 4$ appears as Example 80 in Chou [1988] and as Example 6.231 in Chou-Gao-Zhang [1994]; in these books it is called the Theorem of Pratt-Wu.

References.

S.-C. Chou, *Mechanical Geometry Theorem Proving*. Reidel, Boston 1988.

S.-C. Chou, X.-S. Gao and J.-Z. Zhang, *Machine Proofs in Geometry. Automated Production of Readable Proofs for Geometry Theorems*. World Scientific, Singapore 1994.

Added note.

For an analytic proof of Theorem 8.2 we may proceed as follows.

The circle C_j through vertices $V_j = (x_j, y_j)$ and $V_{j+1} = (x_{j+1}, y_{j+1})$ and the Ceva-point $C = (c, d)$ has equation

$$F_j(x, y) = \begin{vmatrix} x^2 + y^2 & 2x & 2y & 1 \\ c^2 + d^2 & 2c & 2d & 1 \\ x_j^2 + y_j^2 & 2x_j & 2y_j & 1 \\ x_{j+1}^2 + y_{j+1}^2 & 2x_{j+1} & 2y_{j+1} & 1 \end{vmatrix} = 0,$$

and the tangent T_j to C_j at C has therefore the equation

$$f_j(x, y) = \begin{vmatrix} cx + dy & x+c & y+d & 1 \\ c^2 + d^2 & 2c & 2d & 1 \\ x_j^2 + y_j^2 & 2x_j & 2y_j & 1 \\ x_{j+1}^2 + y_{j+1}^2 & 2x_{j+1} & 2y_{j+1} & 1 \end{vmatrix} = 0.$$

Denoting by L_j the line determined by V_j and V_{j+1} , and by W_j the intersection of L_j and T_j , it follows from Chasles' theorem that $\left[\frac{V_j W_j}{W_j V_{j+1}} \right] = -\frac{f_j(x_j, y_j)}{f_j(x_{j+1}, y_{j+1})}$.

But since

$$f_j(x_j, y_j) = 2 (d x_j - d x_{j+1} - c y_j + c y_{j+1} - x_j y_{j+1} + x_{j+1} y_j) \\ (c^2 + d^2 - 2 c x_j + x_j^2 - 2 d y_j + y_j^2),$$

and

$$f_j(x_{j+1}, y_{j+1}) = 2 (d x_j - d x_{j+1} - c y_j + c y_{j+1} - x_j y_{j+1} + x_{j+1} y_j) \\ (c^2 + d^2 - 2 c x_{j+1} + x_{j+1}^2 - 2 d y_{j+1} + y_{j+1}^2),$$

we have

$$\left[\frac{V_j W_j}{W_j V_{j+1}} \right] = -\frac{c^2 + d^2 - 2 c x_j + x_j^2 - 2 d y_j + y_j^2}{c^2 + d^2 - 2 c x_{j+1} + x_{j+1}^2 - 2 d y_{j+1} + y_{j+1}^2}.$$

Therefore the cyclic product of all the ratios has the value $(-1)^n$.

9. Circle transversality theorems.

As in Section 8, we shall be concerned here with circular products of ratios determined by circles -- but now we shall intersect by sides (or diagonals) of polyacrons the circles themselves, and not tangents to them. The first result is a Menelaus-type theorem.

Theorem 9.1. Given an n -acron P with vertices V_i , where $i = 1, 2, \dots, n$, and a circle C . Let $X_i^{(1)}$ and $X_i^{(2)}$ be the intersection points of the line $\langle V_i V_{i+k} \rangle$ with C , for a fixed k with $1 \leq k < n/2$. Then

$$\prod_{1 \leq i \leq n} \left[\frac{X_i^{(1)} V_i}{X_i^{(1)} V_{i+k}} \right] \cdot \left[\frac{X_i^{(2)} V_i}{X_i^{(2)} V_{i+k}} \right] = 1.$$

The notation is illustrated for $n = 5$ in Figure 9.1.

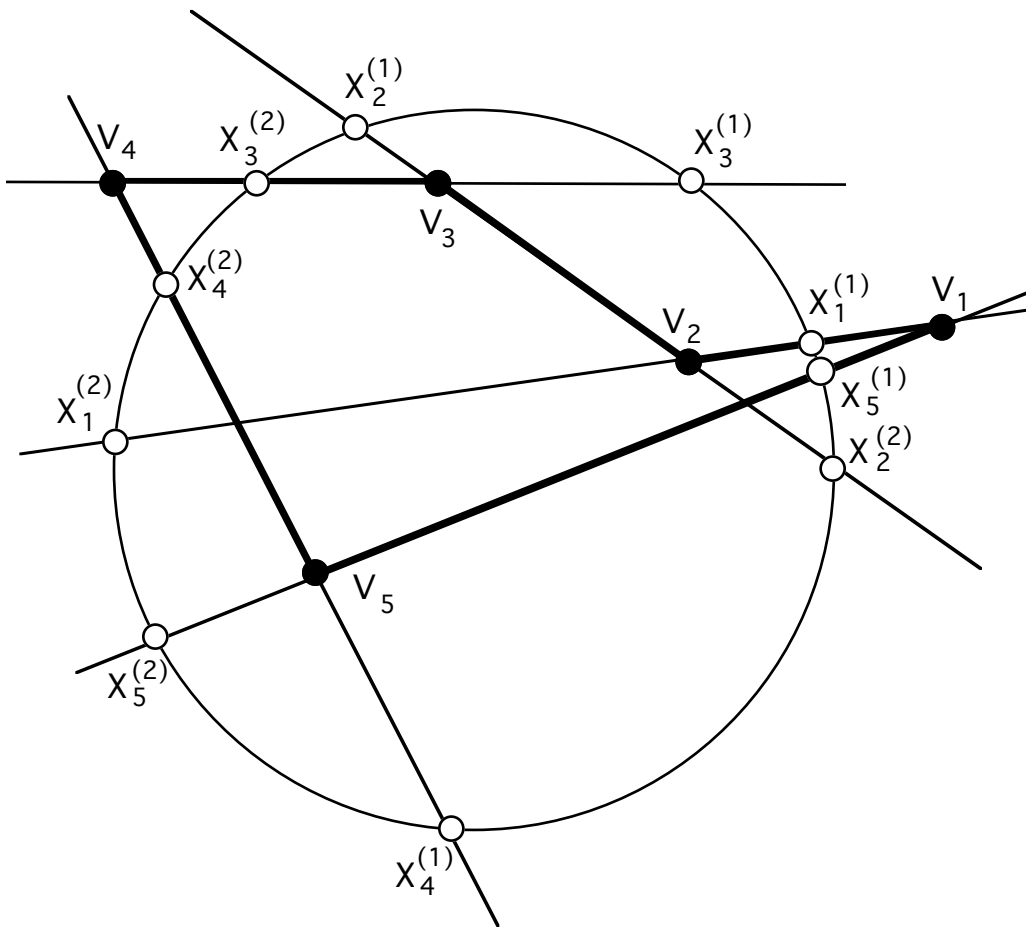

Figure 9.1. An illustration of Theorem 9.1 in case $n = 5$.

The proof of Theorem 9.1 is extremely simple; it relies on the theorem about the "power of a point with respect to a circle". This theorem associates with every point a real number, such that if a line through the point meets the circle, then the product of the lengths of the segments from the point to the circle equals that number. In the notation of Figure 9.2, $AB^* \cdot AB^{**} = AC^* \cdot AC^{**}$. Therefore, in the product of Theorem 9.1, each product of numerators will also appear as product of denominators in another pair of fractions, — hence all will cancel. We shall discuss at the end of this section the possibility that some of the sides of the polyacron do not meet the circle.

In analogy to the sequence Menelaus \rightarrow Ceva \rightarrow Selftransversality, in the case of circles we have the following three theorems in addition to the one above.

Theorem 9.2. Given an n -acron P with vertices V_i , where $i = 1, 2, \dots, n$, and fixed points Q_1 and Q_2 . Let C_i be the circumcircle of Q_1, Q_2 , and V_i , and let $X_i^{(1)}$ and $X_i^{(2)}$ be the intersection points of the line V_{i-k}, V_{i+k} with the circle C_i . Then

$$\prod_{1 \leq i \leq n} \left[\frac{X_i^{(1)} V_{i-k}}{X_i^{(1)} V_{i+k}} \right] \cdot \left[\frac{X_i^{(2)} V_{i-k}}{X_i^{(2)} V_{i+k}} \right] = (-1)^n$$

for all k such that $1 \leq k < n/2$.

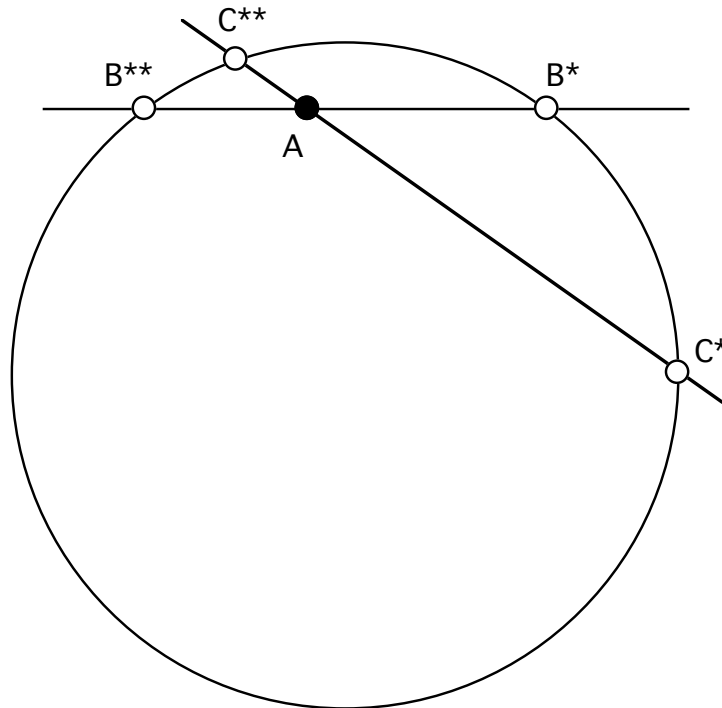

Figure 9.2. An illustration of the "power of a point with respect to a circle" theorem. The point A common to the two transversals may just as well be on the circle, or outside of it.

Theorem 9.3. Given an n -acron P with vertices V_i , where $i = 1, 2, \dots, n$, and a fixed point Q ; let C_i be the circumcircle of Q, V_{i+k}, V_{i+2k} , and let $X_i^{(1)}$ and $X_i^{(2)}$ be the intersection points of the line V_i, V_{i+3k} with the circle C_i . Then

$$\prod_{1 \leq i \leq n} \left[\frac{X_i^{(1)} V_i}{X_i^{(1)} V_{i+3k}} \right] \cdot \left[\frac{X_i^{(2)} V_i}{X_i^{(2)} V_{i+3k}} \right] = 1.$$

for all k such that $1 \leq k < n/2$ and $k \neq n/3$.

Theorem 9.4. Given an n -acron P with vertices V_i , where $i = 1, 2, \dots, n$, let C_i be the circumcircle of V_i, V_{i-j}, V_{i+j} , and let $X_i^{(1)}$ and $X_i^{(2)}$ be the intersection points of the line V_{i-k}, V_{i+k} with the circle C_i . Then

$$\prod_{1 \leq i \leq n} \left[\frac{X_i^{(1)} V_{i-k}}{X_i^{(1)} V_{i+k}} \right] \cdot \left[\frac{X_i^{(2)} V_{i-k}}{X_i^{(2)} V_{i+k}} \right] = (-1)^n$$

if either (i) $1 \leq j < n/2$, $j \neq n/4$, $j \neq n/3$, and $k = 2j \pmod{n}$;
or else (ii) $k \geq 1$, $j = 2k$, and $n = 6k$.

Theorems 9.2, 9.3 and 9.4 have been extensively verified by numerical checking. It is pretty clear that there must be algebraic cancellation of the factors involved in the cyclic products; however, I have not been able to clear a path through the stifling jungle of polynomials and roots. Neither have I been able to find any geometric arguments. More about Theorem 9.1 will be presented in the next section.

I am certain that all theorems of this section could be strengthened to say that the cases listed are the only ones in which the cyclic products equal ± 1 .

It is very remarkable that all the theorems of this section remain valid for many families of curves other than circles. Very extensive numerical experiments showed this to be the case, for example, for the 3-parameter family of parabolas given by equations of the type $y = ax^2 + bx + c$ and the 3-parameter family of hyperbolas given by equations of the type $xy = ax + by + c$. Since the theorems are affinely invariant, this shows that they are valid for many 3-parameter families of nondegenerate conic sections. It may be conjectured that it is valid for all those 3-parameter families of nondegenerate conic sections for which each triplet of points uniquely determines a curve of the family.

However, the validity of the above results is not limited to conic sections. In extensive numerical experiments it turned out that with appropriate modifications they apply, for example, to cubic curves of the type $y = ax^3 + bx^2 + cx + d$ (called "cubic parabolas" in the sequel), along with many other examples. (The full scope of relevant families of curves is not known.) The main change from theorems 9.1 to 9.4 is that the results for the cubics correspond to those theorems for circles which have the same number of variable points used in the determination of the curves (and not the number of fixed "Ceva" points). Naturally, the ratios now extend over all three intersection points on each line. Thus we have the following analogue of Theorems 9.1 to 9.4:

Theorem 9.5. Given an n -acron P with vertices V_i , where $i = 1, 2, \dots, n$, and a cubic parabola C . Let $X_i^{(1)}$, $X_i^{(2)}$ and $X_i^{(3)}$ be the intersection points of the line $\langle V_i V_{i+k} \rangle$ with C , for a fixed k with $1 \leq k < n/2$. Then

$$\prod_{1 \leq i \leq n} \prod_{1 \leq t \leq 3} \left[\frac{X_i^{(t)} V_{i-k}}{X_i^{(t)} V_{i+k}} \right] = 1.$$

Theorem 9.6. Given an n -acron P with vertices V_i , where $i = 1, 2, \dots, n$. Let C_i be the cubic parabola determined by the fixed points Q_1, Q_2, Q_3 and the vertex V_i , and let $X_i^{(1)}$, $X_i^{(2)}$ and $X_i^{(3)}$ be the intersection points of the line $\langle V_{i-k}, V_{i+k} \rangle$ with the cubic parabola C_i . Then

$$\prod_{1 \leq i \leq n} \prod_{1 \leq t \leq 3} \left[\frac{X_i^{(t)} V_{i-k}}{X_i^{(t)} V_{i+k}} \right] = (-1)^n$$

for all k such that $1 \leq k < n/2$.

Theorem 9.7. Given an n -acron P with vertices V_i , where $i = 1, 2, \dots, n$. Let C_i be the cubic parabola determined by the fixed points Q_1, Q_2 , and the vertices V_{i+k}, V_{i+2k} , and let $X_i^{(1)}$ and $X_i^{(2)}$ be the intersection points of the line $\langle V_i, V_{i+3k} \rangle$ with the cubic parabola C_i . Then

$$\prod_{1 \leq i \leq n} \prod_{1 \leq t \leq 2} \left[\frac{X_i^{(t)} V_{i-k}}{X_i^{(t)} V_{i+3k}} \right] = 1.$$

for all k such that $1 \leq k < n/2$ and $k \neq n/3$.

Theorem 9.8. Given an n -acron P with vertices V_i , where $i = 1, 2, \dots, n$, and a point Q ; let C_i be the cubic parabola determined by the points Q, V_i, V_{i-j}, V_{i+j} , and let $X_i^{(1)}, X_i^{(2)}$ and $X_i^{(3)}$ be the intersection points of the line $\langle V_{i-k}, V_{i+k} \rangle$ with the cubic C_i . Then

$$\prod_{1 \leq i \leq n} \prod_{1 \leq t \leq 3} \left[\frac{X_i^{(t)} V_{i-k}}{X_i^{(t)} V_{i+k}} \right] = (-1)^n$$

if either (i) $1 \leq j < n/2$, $j \neq n/4$, $j \neq n/3$, and $k = 2j \pmod{n}$;
or else (ii) $k \geq 1$, $j = 2k$, and $n = 6k$.

However, there is also an additional result, in which no fixed point enters the determination of the cubic curve; it is thus a different analogue of Theorem 9.4.

Theorem 9.9. Given an n -acron P with vertices V_i , where $i = 1, 2, \dots, n$. Let C_i be the cubic parabola determined by the vertices $V_{i+k}, V_{i+j+k}, V_{i+2j+k}, V_{i+3j+k}$, and let $X_i^{(1)}$ and $X_i^{(2)}$ be the intersection points of the line $\langle V_i, V_{i+3j+2k} \rangle$ with the cubic parabola C_i . Then

$$\prod_{1 \leq i \leq n} \prod_{1 \leq t \leq 3} \left[\frac{X_i^{(t)} V_i}{X_i^{(t)} V_{i+3j+2k}} \right] = 1.$$

if either (i) $1 \leq j < n/3$, $j \neq n/5$, $j \neq n/4$, and $k = j \pmod{n}$;
or else (ii) $k \leq -1$, $j = -2k$, and $n = -8k$.

10. A basic lemma and some applications.

The following lemma gives an inkling of the type of theorems that one may expect, and it can be used to simply prove some of them. It is possible that the other results of Section 9 (for example) can also be proved using this lemma; however, the algebra appears to be beyond managing.

Let $X = (x_1, x_2)$ be an arbitrary point, and let $p(X) = p(x_1, x_2)$ be a polynomial in x_1, x_2 , of degree $d = \max\{i+j : \text{the coefficient of } x_1^i x_2^j \text{ in } p(X) \text{ is nonzero}\}$. Let $C = \{X : p(X) = 0\}$ be the curve determined by $p(X)$. Throughout, the coordinates of X and the coefficients of p are allowed to be complex numbers. Given points $A = (a_1, a_2)$ and $B = (b_1, b_2)$, let $L_{AB} = \langle A, B \rangle = \{g(t) = (1-t)A + tB : t \text{ any complex number}\}$ be the line determined by A and B . Let $S = \{S_1, S_2, \dots, S_d\} = C \cap L_{AB}$ be the intersection points of C with L_{AB} ; counting multiplicities, there always are d such points. With this notation, we have:

Lemma.
$$\prod_{1 \leq i \leq d} \left[\frac{S_i A}{S_i B} \right] = \frac{p(A)}{p(B)} .$$

Proof. Since the points S_i are on L_{AB} , there exist (possibly complex) numbers t_1, t_2, \dots, t_n such that $S_i = (1-t_i)A + t_i B = g(t_i)$ for all i . Now, $h(t) = p(g(t))$ is a polynomial in t , of degree d , the zeros of which are precisely the numbers t_1, t_2, \dots, t_d . Therefore $h(t) = K(t-t_1)(t-t_2) \dots (t-t_d)$, where K is a number that does not depend on t . If $X = g(t)$ is any point of L_{AB} , then $X - S_i = (1-t)A + tB - ((1-t_i)A + t_i B) = (B-A)(t-t_i) = ((b_1-a_1)(t-t_i), (b_2-a_2)(t-t_i))$. Since each ratio $\left[\frac{S_i A}{S_i B} \right]$ equals the ratio of the first components, we have

$$\begin{aligned} \prod_{1 \leq i \leq d} \left[\frac{S_i A}{S_i B} \right] &= \prod_{1 \leq i \leq d} \left(\frac{(b_1 - a_1)(t - t_i) |_{t=0}}{(b_1 - a_1)(t - t_i) |_{t=1}} \right) \\ &= \prod_{1 \leq i \leq d} \left(\frac{K(t - t_i) |_{t=0}}{K(t - t_i) |_{t=1}} \right) = \frac{h(0)}{h(1)} = \frac{p(A)}{p(B)} . \quad \sim \end{aligned}$$

We shall give two examples of the use of this Lemma.

First, here is an analytical proof of Theorem 8.2. Denoting by L_j the line determined by V_j and V_{j+k} , and by W_j the intersection of L_j and T_j , it follows from the Lemma that $\left[\frac{V_j W_j}{W_j V_{j+k}} \right] = -\frac{f(x_j, y_j)}{f(x_{j+k}, y_{j+k})}$. But since

$$f(X_j) = 2 (d x_j - d x_{j+1} - c y_j + c y_{j+k} - x_j y_{j+k} + x_{j+k} y_j) \\ (c^2 + d^2 - 2 c x_j + x_j^2 - 2 d y_j + y_j^2),$$

and

$$f(X_{j+k}) = 2 (d x_j - d x_{j+k} - c y_j + c y_{j+k} - x_j y_{j+k} + x_{j+k} y_j) \\ (c^2 + d^2 - 2 c x_{j+k} + x_{j+k}^2 - 2 d y_{j+k} + y_{j+k}^2),$$

we have

$$\left[\frac{V_j W_j}{W_j V_{j+k}} \right] = - \frac{c^2 + d^2 - 2 c x_j + x_j^2 - 2 d y_j + y_j^2}{c^2 + d^2 - 2 c x_{j+k} + x_{j+k}^2 - 2 d y_{j+k} + y_{j+k}^2}.$$

Therefore in the cyclic product of all the ratios we have complete cancellation, hence the product has the value $(-1)^n$, as claimed. ~

Similar, but slightly messier, is the analytical proof of Theorem 8.5. (I discovered that some 15 months ago I had had the patience to work it out.) If the Ceva point is $Q = (c,d)$, the conic C_j through Q and the vertices $V_i, V_{i+k}, V_{i+2k}, V_{i+3k}$ has equation

$$F(x,y) = \begin{vmatrix} x^2 & 2xy & y^2 & 2x & 2y & 1 \\ c^2 & 2cd & d^2 & 2c & 2d & 1 \\ x_j^2 & 2x_j y_j & y_j^2 & 2x_j & 2y_j & 1 \\ x_{j+k}^2 & 2x_{j+k} y_{j+k} & y_{j+k}^2 & 2x_{j+k} & 2y_{j+k} & 1 \\ x_{j+2k}^2 & 2x_{j+2k} y_{j+2k} & y_{j+2k}^2 & 2x_{j+2k} & 2y_{j+2k} & 1 \\ x_{j+3k}^2 & 2x_{j+3k} y_{j+3k} & y_{j+3k}^2 & 2x_{j+3k} & 2y_{j+3k} & 1 \end{vmatrix} = 0,$$

and therefore the tangent to C_j at Q has equation

$$f(x,y) = \begin{vmatrix} cx & xd+yc & dy & x+c & y+d & 1 \\ c^2 & 2cd & d^2 & 2c & 2d & 1 \\ x_j^2 & 2x_j y_j & y_j^2 & 2x_j & 2y_j & 1 \\ x_{j+k}^2 & 2x_{j+k} y_{j+k} & y_{j+k}^2 & 2x_{j+k} & 2y_{j+k} & 1 \\ x_{j+2k}^2 & 2x_{j+2k} y_{j+2k} & y_{j+2k}^2 & 2x_{j+2k} & 2y_{j+2k} & 1 \\ x_{j+3k}^2 & 2x_{j+3k} y_{j+3k} & y_{j+3k}^2 & 2x_{j+3k} & 2y_{j+3k} & 1 \end{vmatrix} = 0.$$

Denoting by L_j the line determined by V_j and V_{j+1} , and by W_j the intersection of L_j

and T_j , it follows from the Lemma that $\left[\frac{V_j W_j}{W_j V_{j+3k}} \right] = - \frac{f(x_j, y_j)}{f(x_{j+3k}, y_{j+3k})}$.

Putting, for simplicity, $\begin{vmatrix} p \\ r \\ s \end{vmatrix} = \begin{vmatrix} p_1 & p_2 & 1 \\ r_1 & r_2 & 1 \\ s_1 & s_2 & 1 \end{vmatrix}$, it is a routine (but tedious)

computation to verify that

$$f(V_j) = - \begin{vmatrix} V_j \\ V_{j+3k} \\ Q \end{vmatrix} \begin{vmatrix} V_{j+k} \\ V_{j+2k} \\ V_{j+3k} \end{vmatrix} \begin{vmatrix} V_j \\ V_{j+k} \\ Q \end{vmatrix} \begin{vmatrix} V_j \\ V_{j+2k} \\ Q \end{vmatrix} \text{ and}$$

$$f(V_{j+3k}) = \begin{vmatrix} V_j \\ V_{j+3k} \\ Q \end{vmatrix} \begin{vmatrix} V_j \\ V_{j+k} \\ V_{j+2k} \end{vmatrix} \begin{vmatrix} V_{j+k} \\ V_{j+3k} \\ Q \end{vmatrix} \begin{vmatrix} V_{j+2k} \\ V_{j+3k} \\ Q \end{vmatrix} ;$$

therefore

$$\left[\frac{V_j W_j}{W_j V_{j+3k}} \right] = \begin{vmatrix} V_{j+k} \\ V_{j+2k} \\ V_{j+3k} \end{vmatrix} \begin{vmatrix} V_j \\ V_{j+k} \\ Q \end{vmatrix} \begin{vmatrix} V_j \\ V_{j+2k} \\ Q \end{vmatrix} / \begin{vmatrix} V_j \\ V_{j+k} \\ V_{j+2k} \end{vmatrix} \begin{vmatrix} V_{j+2k} \\ V_{j+3k} \\ Q \end{vmatrix} \begin{vmatrix} V_{j+k} \\ V_{j+3k} \\ Q \end{vmatrix}$$

It follows that in the cyclic product of such ratios, all factors of the numerators cancel with appropriate factors of the denominators, and the result follows. ~

It is obvious that the Lemma gives at once proofs of Theorems 9.1 and 9.5, and, in fact, of all such "Menelaus-type" results where the sides of a polyacron intersect an algebraic curve. It is possible that the other results of Section 9 can be proved by some clever adaptation of this method — but I have not been able to find it.

SPACES OF POLYGONS

We turn now to the study of a direction in the theory of polygons which has been very slow to emerge in any sort of rounded form. Since the results and ideas we shall be dealing with now are quite distinct from the ones considered so far, it is reasonable to think of this as being a new chapter. This should explain the numbering of sections and chapters, and is even more justified by the fact that I have fallen behind in providing written versions of the presentations in class. I intend to fill this gap, but since it is not clear at this moment how many sections this will make — a new start is really the simplest way. The new pages and sections will carry the letter N, to remind us both of "new" and of "Napoleon". However, it will be a while till we get to the Napoleon stuff ...

N1. Rooted Polygons and Vector Spaces.

In this section we shall define the vector space $\mathbf{V}(n; k)$ of rooted n -gons in the k -dimensional real Euclidean space \mathbf{E}^k , and some of its more important subspaces.

Throughout, $P = [V_0, V_1, \dots, V_{n-1}]$ denotes an arbitrary n -gon with vertices V_0, \dots, V_{n-1} and (directed) edges $[V_i, V_{i+1}]$ ($i = 0, \dots, n - 1$), in \mathbf{E}^k , see Figure N1.1. In order to avoid exceptions and awkward formulations, we shall always assume that $n \geq 3$. Also, as before, all subscripts i are reduced modulo n so they lie in the range $0 \leq i \leq n - 1$. The fact that the edges are directed indicates that the polygons are *oriented*; the symbol $[V_1, \dots, V_{n-1}, V_0]$ represents the same polygon P , and so do all other cyclic permutations of the vertices. On the other hand, $[V_{n-1}, V_{n-2}, \dots, V_0]$ represents a distinct polygon which is said to arise from P by *reversing the orientation*. Coincidences among vertices of polygons P are not excluded by the definition. In particular all vertices of P may coincide, in which case P is called a

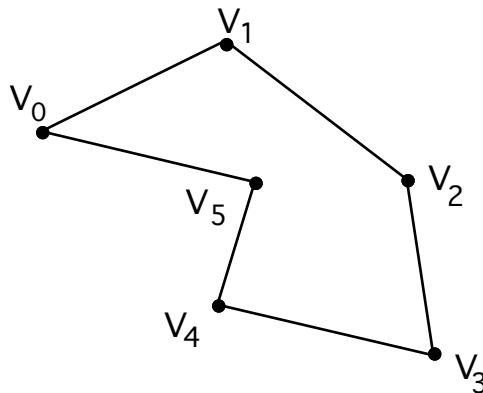

Figure N1.1. Notation for polygons and rooted polygons.

point n-gon or **point polygon**, and if all the vertices lie at the origin of the coordinate system, P is called a **zero n-gon** or **zero polygon**. The set of **all** n -gons in the k -dimensional space \mathbf{E}^k will be denoted by $\mathcal{A}(n;k)$. Since most of our discussion concerns the case $k = 2$, we shall frequently use the simpler notation $\mathcal{A}(n)$ for $\mathcal{A}(n;2)$.

Upper case letters X, Y, A, B, V, \dots , with or without subscripts, will be used for points of \mathbf{E}^k and the corresponding lower case letters x, y, a, b, v, \dots , for their position vectors relative to some arbitrarily chosen origin O . Also, we shall use outline characters for vector spaces and affine spaces, and script characters for sets that are not necessarily vector spaces. The distance between two points A, B will be denoted by $|AB| = |a - b|$. The *centroid* of the polygon $P = [V_0, \dots, V_{n-1}]$, is the point W such that $w = \frac{1}{n} \sum_{j=0}^{n-1} v_j$. For some purposes it is convenient to restrict attention to

polygons whose centroids coincide with the origin; by slight abuse of language we shall say that they are *centered* at the origin. The set of such n -gons will be denoted by $\mathcal{O}(n;k)$, and superscripts will be used with similar meanings in analogous situations.

Although a polygon is unchanged by cyclic permutation of its vertices, for the algebraic approach we follow here it is necessary to distinguish one vertex (the *leading* or *root vertex*); In other words, the objects we shall be working with are pairs consisting of a polygon and one of its vertices. If V_0 is the root vertex of the polygon P we write $P = [V_0, V_1, \dots, V_{n-1}]$, and we associate with this rooted n -gon in \mathbf{E}^k the $n \times k$ matrix (or, more conveniently, the column n -vector whose elements are row k -vectors),

$$\mathbf{v} = \begin{bmatrix} v_0 \\ \cdot \\ \cdot \\ \cdot \\ v_{n-1} \end{bmatrix} = [v_0, \dots, v_{n-1}]^T.$$

Thus each n -gon P corresponds, according to the choice of the root, to n rooted polygons \bar{P} , each of which leads to a column vector \mathbf{v} , the n rows of which are the position vectors of the vertices of P . Except for very special cases (such as when P is a point polygon), these n rooted polygons are distinct. Unless otherwise stated, the root vertex will be denoted by V_0 . Of fundamental importance is the linear space (vector space) $\mathbf{V}(n; k)$ of dimension nk of all such vectors; it is obviously isomorphic to \mathcal{O}^{nk} . Following the earlier convention, we write $\mathbf{V}(n)$ instead of $\mathbf{V}(n; 2)$.

The fundamental operations of the vector space $\mathbb{V}(n; k)$, namely vector sum and scalar multiplication by reals, correspond to operations on the rooted polygons: $\mathbf{v} + \mathbf{w}$ represents the *vertex sum* $\mathbf{P} \oplus \mathbf{Q}$ of the rooted n -gons \mathbf{P} and \mathbf{Q} represented by \mathbf{v} and \mathbf{w} , each vertex of $\mathbf{P} \oplus \mathbf{Q}$ being the vector sum of the *corresponding* vertices of the two summand polygons; also, $\lambda \mathbf{v}$ represents the scalar multiple $\lambda \mathbf{P}$ of \mathbf{P} by the real number λ . These operations are illustrated in Figure N1.2.

Note that the operation of vertex addition of rooted polygons is quite distinct from other methods of adding polygons (such as Minkowski addition and Blaschke addition) to be found in the classical literature of convex sets. In particular, it does not operate among polygons that are not rooted, and different rootings of the same polygons result in general in different vertex sums (see Figure N1.3).

We shall write $\mathbf{V}^O(n; k)$ for the vector space corresponding to rooted n -gons in \mathbf{E}^k that are centered at the origin O ; $\mathbf{V}^O(n; k)$ is a vector subspace of $\mathbf{V}(n; k)$ of dimension $(n - 1)k$. If X is any point then $\mathbf{V}^X(n; k)$ (corresponding to rooted n -gons in \mathbf{E}^k whose centers coincide with the point X) is an affine subspace of $\mathbf{V}(n; k)$, that is, a translation of $\mathbf{V}^O(n; k)$ that contains the point polygon X .

Most of the discussion is devoted to the case $k = 2$. In particular, until further mention, all discussions will be restricted to polygons in the plane, that is, to elements of $\mathcal{A}(n)$.

Let $n \geq 3$ and $0 \leq d < n$ be integers; the *standard regular* (n/d) -gon is the polygon $R = R_{n,d} = [V_0, \dots, V_{n-1}]$ in the plane \mathbf{E}^2 , with vertices given by $v_j = (\cos j\theta, \sin j\theta)$, where $\theta = 2\pi d/n$ and $j = 0, \dots, n - 1$. Each such regular polygon has

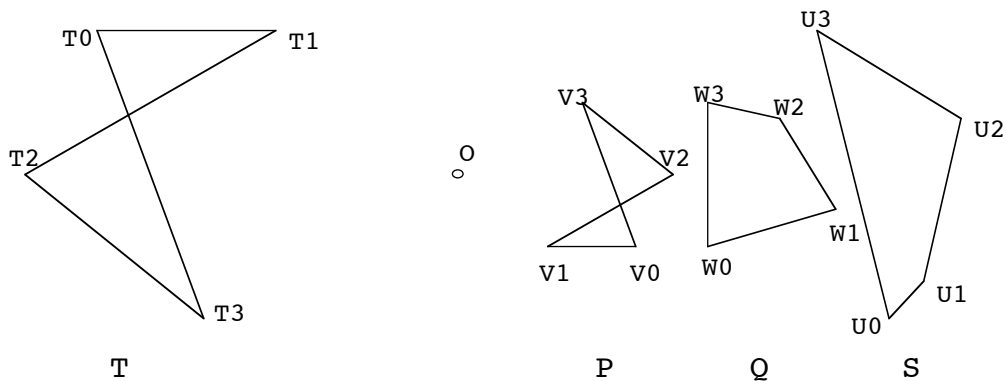

Figure N1.2. Illustrations of the vertex sum and scalar multiplication of rooted polygons. Here $\mathbf{S} = \mathbf{P} \oplus \mathbf{Q}$, and $\mathbf{T} = -2\mathbf{P}$.

an orientation specified by the order of its vertices; if $0 < d < \frac{1}{2}n$ and $e = n - d$, then the standard regular (n/d) -gon and standard regular (n/e) -gon have the same vertices and the same root vertex V_0 ; they differ only in that their edges are oppositely directed, hence they have opposite orientations. Except when $d = 0$, all the standard regular (n/d) -gons $R_{n,d}$ are centered at the origin. In Figure N1.4 we show the examples of all standard regular n -gons with $n \leq 6$.

It is traditional to specify that for regular polygons d and n must be coprime, so the vertices of the (n/d) -gon are all distinct. In the present context it is *absolutely essential* that we *do not* make this restriction; in a later section I'll discuss in more details the rôle and influence of the traditional restriction.

As is easily verified, if $d \neq 0$ and $h = \text{HCF}(n, d)$ is the highest common factor of n and d , then the vertices of a standard regular (n/d) -gon coincide in n/h sets, each consisting of h vertices; the positions of each set coincide with the vertices of a regular $(\frac{n}{h} / \frac{d}{h})$ -gon. For every n , $R_{n,0}$ is a point polygon. The polygon $R_{n,1}$ is **simple**, that is, its edges are disjoint except at the vertices; thus a regular $(n/1)$ -gon is the familiar regular convex n -gon of elementary geometry, which we take as oriented in a positive (counterclockwise) direction. Similarly, a regular $(n/(n-1))$ -gon is a simple, convex

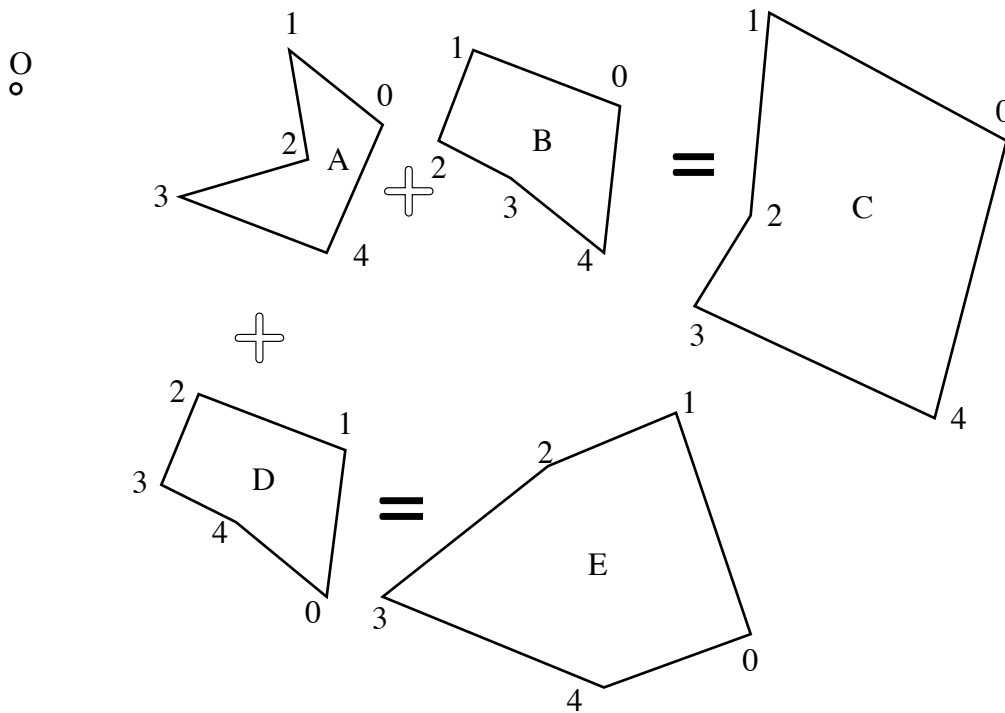

Figure N1.3. Different choices of roots lead to different vertex sums.

polygon oriented in a negative (clockwise) direction. If $1 < d < n-1$ then $R_{n,d}$ is a **regular star polygon**; the most familiar example is the regular $(5/2)$ -gon or **pentagram**. If $n=2m$ is even, the regular (n/m) -gon “degenerates” into n coincident line segments (the edges); their common endpoints (the vertices) are repeated m times each.

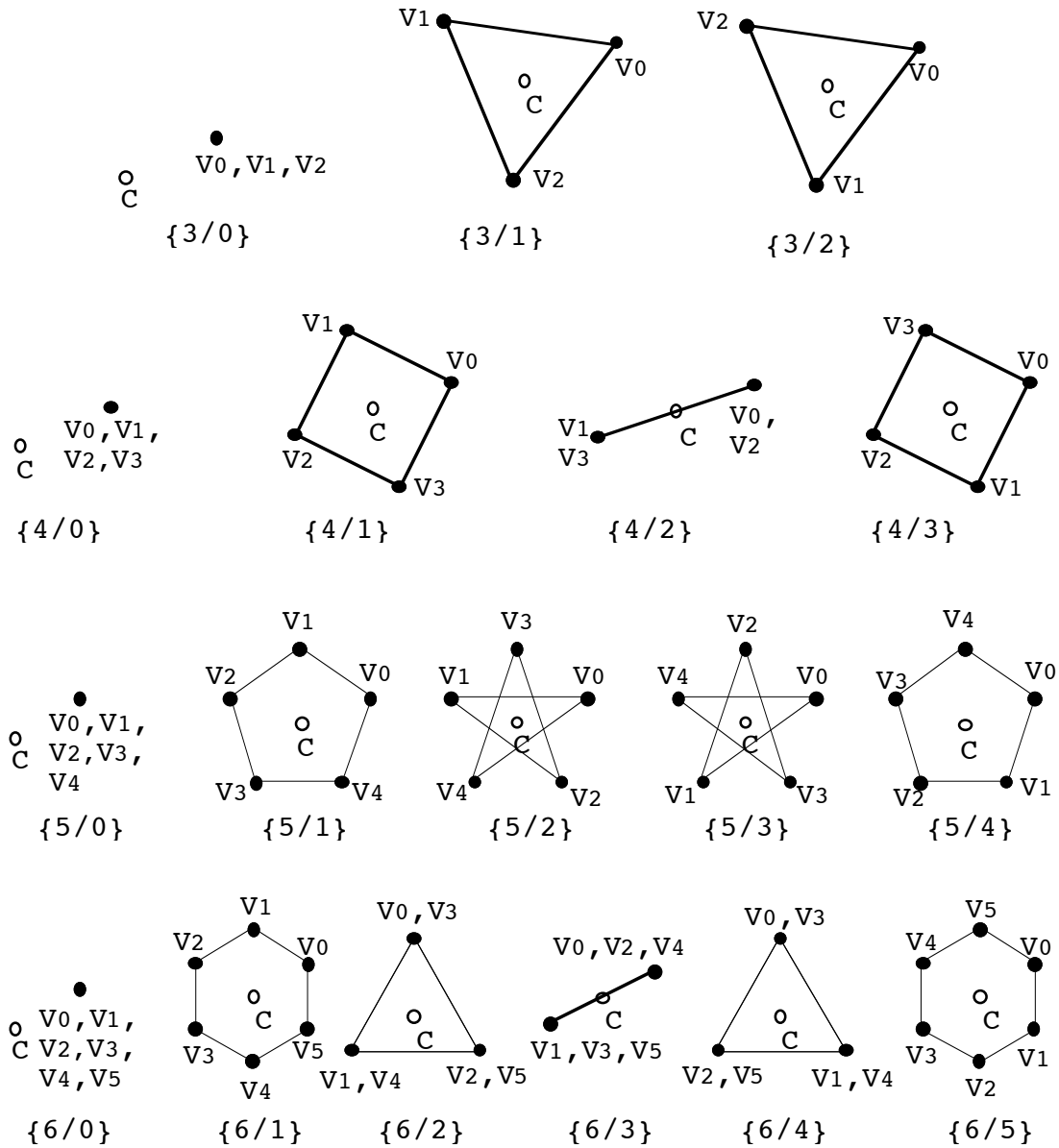

Figure N1.4. The four standard regular quadrangles. The origin is indicated by the hollow dot, and a numeral j stands for the vertex V_j . As an additional means of indicating the root of the polygon and the orientation, in many of the following diagrams the root vertex is indicated by the largest solid dot, the next vertex by an intermediate-sized dot, and all the other vertices by small dots. As an alternative, the root vertex is indicated by a large dot and the orientation is shown by one or more arrows on or along the edges.

A (general) *regular* (n/d) -gon is the image of a *standard* regular (n/d) -gon $R_{n,d}$ under a *similarity*, that is, an isometry followed by a change of scale with **positive** ratio.

The set of all regular rooted (n/d) -gons in \mathbf{E}^2 is denoted by $\mathcal{R}(n/d)$, and, in accordance with our convention, the set of all such polygons which are centered at X is denoted by $\mathcal{R}^X(n/d)$.

For each d such that $0 \leq d < n$, let the set of vectors in $\mathbf{V}(n)$ corresponding to the rooted regular n -gons $\mathcal{R}^O(n/d)$ centered at O be denoted by $\mathbf{W}^O(n/d)$.

Theorem N1.1. If $0 \leq d < n$, then the set $\mathbf{W}^O(n/d)$ is a vector subspace of $\mathbf{V}(n)$ and therefore also of $\mathbf{V}(n)$; its dimension is 2.

Proof. By elementary geometry it is clear that every linear combination (in $\mathbf{V}(n)$) of rooted regular (n/d) -gons is again a rooted regular (n/d) -gon, see Figure N1.5; hence $\mathbf{W}^O(n/d)$ is a vector space. To see that it is 2-dimensional, we consider two possibilities.

If $d = 0$, a centered regular $(n/0)$ -gon is uniquely determined by its root vertex, which can be any point of the plane; hence the vector space $\mathbf{W}^O(n/0)$ is 2-dimensional.

If $d > 0$, to obtain an arbitrary (non-trivial) rooted regular (n/d) -gon centered at the origin from the standard regular (n/d) -gon, we need only rotate the latter through a suitable angle θ and magnify it by factor $a > 0$. Hence,

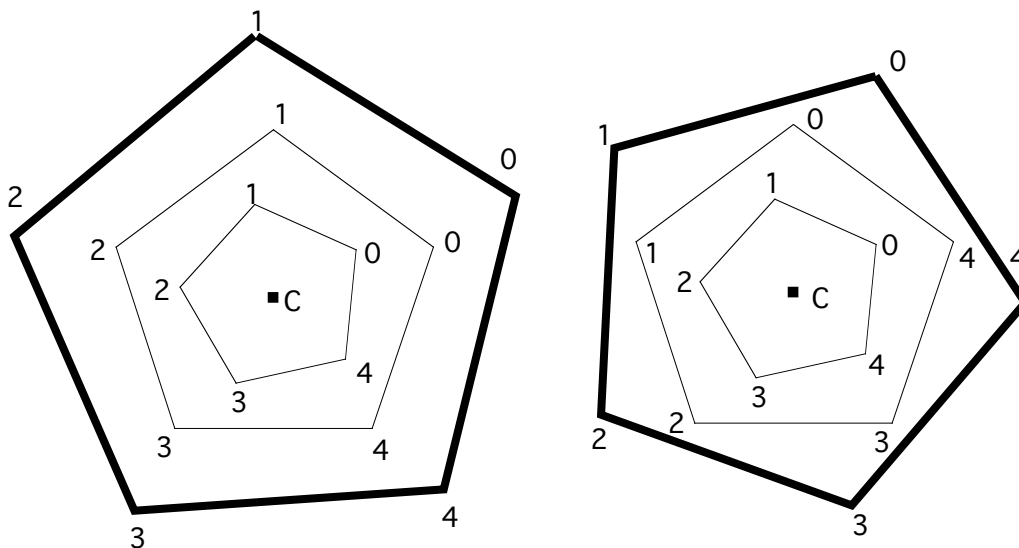

Figure N1.5. The sum of two rooted regular $\{5/1\}$ -gons is itself a rooted regular $\{5/1\}$ -gon. Note that the resulting polygon depends on the choice of roots.

writing $\theta = 2\pi d/n$, this polygon $\bar{\mathbf{R}}(n/d) = [V_0, V_1, \dots, V_{n-1}]$ has vertices, for $j = 0, \dots, n-1$,

$$v_j = (a \cos(j\theta + \delta), a \sin(j\theta + \delta))$$

$$= a(\cos \delta)(\cos j\theta, \sin j\theta) + a(\sin \delta)(-\sin j\theta, \cos j\theta).$$

Writing $v_i^{(d)} = (v_{0,i}^{(d)}, \dots, v_{n-1,i}^{(d)})$ for $i = 1, 2$, where

$$v_{j,1}^{(d)} = (\cos j\theta, \sin j\theta), \quad v_{j,2}^{(d)} = (-\sin j\theta, \cos j\theta)$$

and b, c for the arbitrary real numbers $a \cos \delta, a \sin \delta$, respectively, every vector of $\mathbf{W}^O(n/d)$ can be written in the form

$$b v_1^{(d)} + c v_2^{(d)} \tag{1}$$

Since $v_1^{(d)}$ and $v_2^{(d)}$ are clearly linearly independent, we deduce that $\{v_1^{(d)}, v_2^{(d)}\}$ forms a basis of $\mathbf{W}^O(n/d)$, which is therefore of dimension 2. It is easily checked that the same expression, taken for $d = 0$, yields a basis for $\mathbf{W}^O(n/0)$.

The polygons $v_1^{(1)}$ and $v_2^{(1)}$ for $n = 5$ and $d = 1$ are shown in Figure N1.6.

By elementary linear algebra, much more is true: Since the n subspaces $\mathbf{W}^O(n/d)$ ($d = 0, 1, \dots, n - 1$), have no common elements except the origin, and since each has dimension 2, they span the $(2n)$ -dimensional space $\mathbf{V}(n)$ and the $2n$ vectors $v_1^{(d)}, v_2^{(d)}$ ($d = 0, 1, \dots, n - 1$) form a basis of $\mathbf{V}(n)$. In fact, we shall establish a much stronger and more useful result; for this we need a definition.

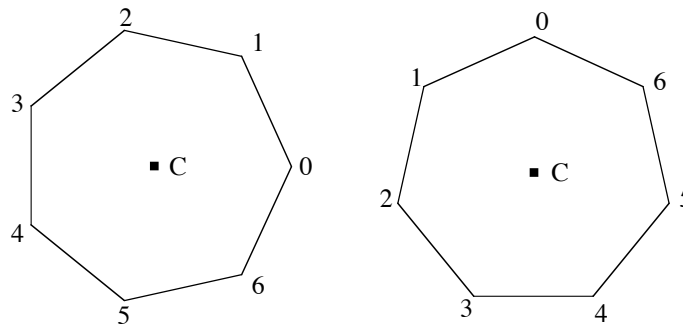

Figure N1.6. The two polygons that form an orthogonal basis of the space $\mathbf{W}^O(5/1)$.

They correspond to the vectors $v_1^{(1)}, v_2^{(1)}$ specified in the text.

Let $\mathbf{v} = [v_0, \dots, v_{n-1}]$ and $\mathbf{w} = [w_0, \dots, w_{n-1}]$ be vectors in $\mathbf{V}(n)$. Then we can define an **inner product** $\langle \cdot, \cdot \rangle$ in $\mathbf{V}(n)$, by

$$\langle \mathbf{v}, \mathbf{w} \rangle = v_0 \cdot w_0 + v_1 \cdot w_1 + \dots + v_{n-1} \cdot w_{n-1}$$

where terms on the right are the standard inner products $a \cdot b = a_1 b_1 + a_2 b_2$ in the plane. It is trivial to check that $\langle \mathbf{v}, \mathbf{w} \rangle$ satisfies all the requirements for inner products, so that $\mathbf{V}(n)$ is an *inner product space*. We have:

Theorem N1.2. The set of $2n$ vectors $\mathbf{v}_1^{(d)}, \mathbf{v}_2^{(d)}$ ($d = 0, 1, \dots, n-1$) specified above is an *orthogonal basis* of the inner product space $\mathbf{V}(n)$. In fact, if scaled by $1/\sqrt{n}$ these vectors form an *orthonormal basis* of $\mathbf{V}(n)$.

Proof. By standard trigonometric identities, it follows that for all d_1, d_2 , with $\theta_1 = 2\pi d_1/n$ and $\theta_2 = 2\pi d_2/n$,

$$\begin{aligned} \langle \mathbf{v}_1^{(d_1)}, \mathbf{v}_2^{(d_2)} \rangle &= \sum_{j=0}^{n-1} [(\cos j\theta_1)(-\sin j\theta_2) + (\sin j\theta_1)(\cos j\theta_2)] \\ &= \sum_{j=0}^{n-1} \sin j(\theta_1 - \theta_2) = 0. \end{aligned}$$

$$\begin{aligned} \langle \mathbf{v}_1^{(d_1)}, \mathbf{v}_1^{(d_2)} \rangle &= \sum_{j=0}^{n-1} [(\cos j\theta_1)(\cos j\theta_2) + (\sin j\theta_1)(\sin j\theta_2)] \\ &= \sum_{j=0}^{n-1} \cos j(\theta_1 - \theta_2) = \begin{cases} 0 & \text{if } d_1 \neq d_2 \\ n & \text{if } d_1 = d_2 \end{cases}, \end{aligned}$$

and

$$\begin{aligned} \langle \mathbf{v}_2^{(d_1)}, \mathbf{v}_2^{(d_2)} \rangle &= \sum_{j=0}^{n-1} [(-\sin j\theta_1)(-\sin j\theta_2) + (\cos j\theta_1)(\cos j\theta_2)] \\ &= \sum_{j=0}^{n-1} \cos j(\theta_1 - \theta_2) = \begin{cases} 0 & \text{if } d_1 \neq d_2 \\ n & \text{if } d_1 = d_2 \end{cases} \cdot \diamond \end{aligned}$$

We note that Theorem N1.2 implies, in particular, that for $d = 0, 1, \dots, n-1$, the set $\{\mathbf{v}_1^{(d)}, \mathbf{v}_2^{(d)}\}$ is an orthogonal basis of $\mathbf{W}^0(n/d)$. Also, the subspaces $\mathbf{W}^0(n/0), \mathbf{W}^0(n/1), \dots, \mathbf{W}^0(n/(n-1))$ are mutually orthogonal, and $\mathbf{V}(n)$ is their direct sum,

$$\mathbf{W}^0(n) = \mathbf{W}^0(n/0) \oplus \mathbf{W}^0(n/1) \oplus \dots \oplus \mathbf{W}^0(n/(n-1)). \quad (2)$$

Therefore each $\mathbf{v} \in \mathbf{V}(n)$ can be written **uniquely** in the form

$$\mathbf{v} = \mathbf{w}_0 + \mathbf{w}_1 + \dots + \mathbf{w}_{n-1} \quad (3)$$

where $\mathbf{w}_d \in \mathbf{W}^{0(n/d)}$ for $d = 0, 1, \dots, n-1$. In the notation of rooted polygons, this becomes

$$\bar{P} = \bar{R}^{0(n/0)} + \bar{R}^{0(n/1)} + \dots + \bar{R}^{0(n/n-1)}, \quad (4)$$

and the representation is uniquely determined.

The polygons $\bar{R}^{0(n/d)}$, $d = 1, 2, \dots, n-1$ in (4) are called the **regular components** of \bar{P} . The expression (4) for an arbitrary n -gon in terms of its regular components is analogous to that of an arbitrary periodic function as a Fourier series. As we shall see, this leads to a powerful method for investigating n -gons.

From the general theory of inner product spaces it follows that each \mathbf{w}_d in (3) is the orthogonal projection of $\mathbf{v} \in \mathbf{V}^{0(n)}$ onto $\mathbf{W}^{0(n/d)}$. Hence

Corollary N1.1. If \mathbf{v} is the vector representing the rooted n -gon \bar{P} , the vector \mathbf{w}_d of the regular component $\bar{R}^{0(n/d)}$ of \bar{P} is given by

$$\mathbf{w}_d = \frac{1}{n} \langle \mathbf{v}, \mathbf{v}_1^{(d)} \rangle \mathbf{v}_1^{(d)} + \frac{1}{n} \langle \mathbf{v}, \mathbf{v}_2^{(d)} \rangle \mathbf{v}_2^{(d)}.$$

Therefore

$$\mathbf{v} = \sum_{d=1}^{n-1} \mathbf{w}_d = \sum_{d=1}^{n-1} \left(\frac{1}{n} \langle \mathbf{v}, \mathbf{v}_1^{(d)} \rangle \mathbf{v}_1^{(d)} + \frac{1}{n} \langle \mathbf{v}, \mathbf{v}_2^{(d)} \rangle \mathbf{v}_2^{(d)} \right).$$

Moreover, each of the regular components $\bar{R}^{0(n/d)}$ of \bar{P} is the best possible approximation to \bar{P} amongst all the polygons in $\mathcal{R}^{0(n/d)}$, in the sense of the metric induced by the inner product.

Some illustrations of this corollary are shown in Figure N1.7.

In the next section we shall consider an analogous development, dealing with *affinely regular polygons*.

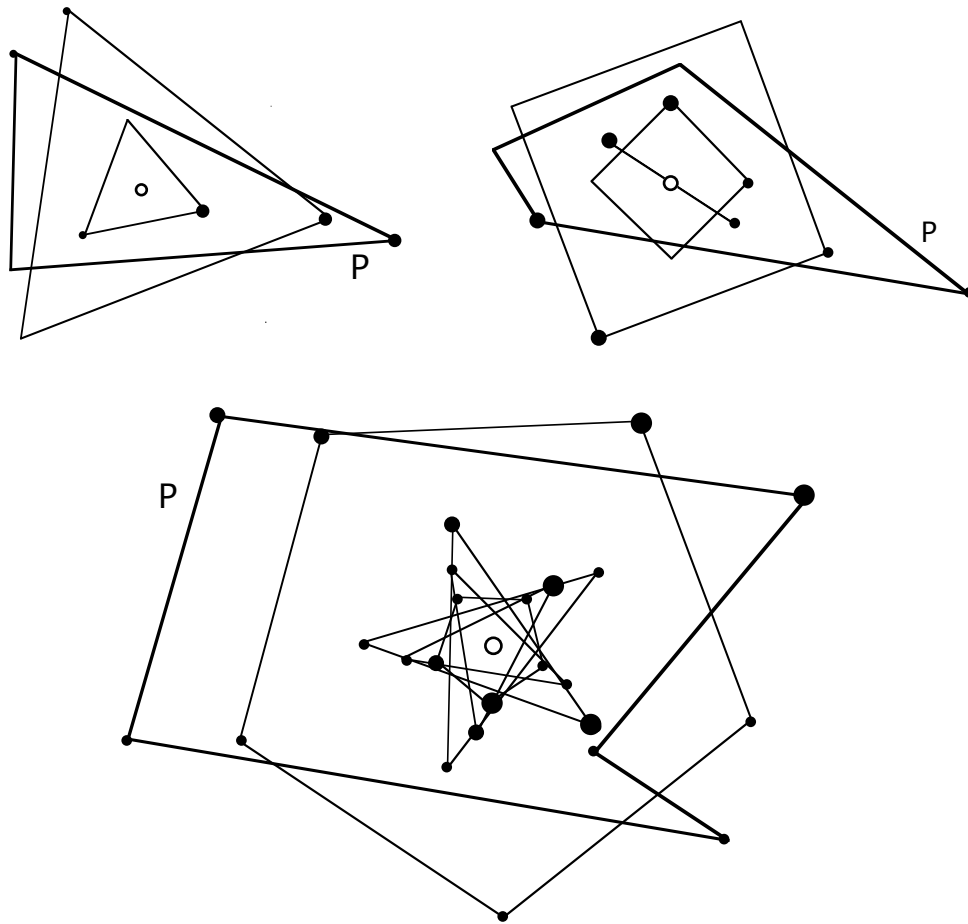

Figure N1.7. The regular components of an n -gon P . The dots of various sizes indicate not only the orientation of the polygons, but also the vertices of the regular components which add up to the vertex of P represented by the same kind of dot. The hollow dot indicates the origin.

N2. Affinely Regular Polygons

In this section we shall explore a setup parallel to the one we dealt with in Section N1. The previous one was essentially Euclidean, while the present topic belongs essentially to affine geometry. We shall find affine analogues to the Euclidean results, and see how they relate to each other. We shall also see one generalization of Napoleon's theorem and a related fact.

An **affine transformation** α in \mathbf{E}^k is a mapping $X \rightarrow \lambda(X) + t$, where λ is a linear transformation and t is a translation vector. Affine geometry is concerned with properties of figures which are preserved under affine transformations. Affine transformations preserve parallelism and ratios of lengths in parallel directions; they do not, in general, preserve lengths, angles or orientations. An **affinely regular (n/d)-gon** is the image of a regular (n/d)-gon under an affine transformation α (see Figure N2.1). The family of all affinely regular (n/d)-gons will be denoted by $\mathcal{A}(n/d)$. Clearly, every triangle is an affinely regular (3/1)-gon, and parallelograms are affinely regular (4/1)-gons.

Notice that the affine transformation α may be singular (that is, the linear transformation λ may be singular), in which case the vertices of the resulting affinely regular polygon may be collinear, or the polygon may be a point polygon. In either case we shall say that the affinely regular polygon is **degenerate**.

It may seem strange that although affine geometry is more general than Euclidean geometry, we defined "affinely regular polygons" in terms of regular polygons which are essentially Euclidean. This is the traditional approach; in the next section we shall present a purely affine characterization of affinely regular polygons, which will enable us to work entirely within the framework of affine geometry.

Since an affine transformation may reverse the orientation of a polygon, the sets $\mathcal{A}(n/d)$ and $\mathcal{A}(n/(n-d))$ coincide. Hence, when considering affinely regular (n/d)-gons there is no loss of generality in restricting d to the values $0 \leq d \leq m = \lfloor n/2 \rfloor$. For each such d , the set of vectors in $\mathbf{V}(n)$ that correspond to the rooted affinely regular (n/d)-gons $\bar{A}^O(n/d) \in \mathcal{A}(n/d)$ centered at O will be denoted by $\mathbf{U}^O(n/d)$.

The analogue of Theorem N1.1 for affinely regular polygons is the following:

Theorem N2.1. The set $\mathbf{U}^O(n/d)$ is a vector subspace of $\mathbf{V}^O(n)$ and therefore also of $\mathbf{V}(n)$. Its dimension is 4, except that the dimension is 2 when $d = 0$ or when n is even and $d = n/2$.

Proof. Using the notation from Section N1, each vector of $\mathbf{W}^0(n/d)$ can be written in the form $b \mathbf{v}_1^{(d)} + c \mathbf{v}_2^{(d)}$. Hence, applying the linear transformation λ , each non-zero vector $\mathbf{u}^{(d)}$ of $\mathbf{U}^0(n/d)$ can be written as

$$\mathbf{u}^{(d)} = \lambda (b \mathbf{v}_1^{(d)} + c \mathbf{v}_2^{(d)}).$$

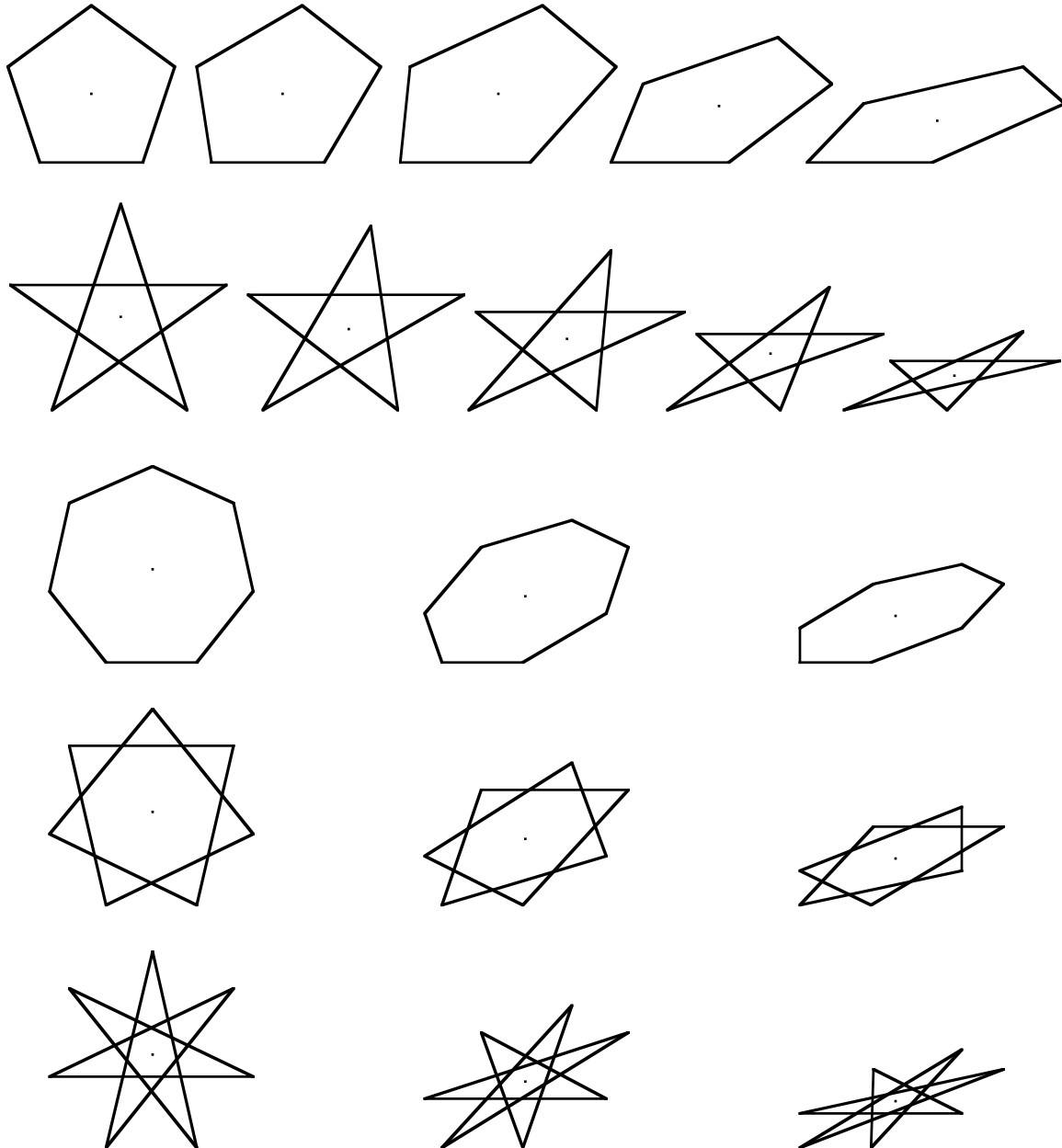

Figure N2.1. Examples of affinely regular pentagons and heptagons. In each row, the first polygon is regular. The first polygon in each row is regular and those following are affine images of it. They therefore belong to $\mathcal{A}(5/1)$, $\mathcal{A}(5/2)$, $\mathcal{A}(7)$, $\mathcal{A}(7/2)$ and $\mathcal{A}(7/3)$, respectively.

Since linear combinations of linear transformations are linear transformations, $\mathbf{U}^{O(n/d)}$ is a vector space. The component vectors of $\mathbf{u}^{(d)}$ are, for $j = 0, \dots, n-1$,

$$\mathbf{u}_j^{(d)} = \lambda \left(b (\cos j\theta, \sin j\theta) + c (-\sin j\theta, \cos j\theta) \right)$$

where $\theta = 2\pi d/n$. If the linear transformation λ is represented by the matrix $\begin{bmatrix} p & q \\ r & s \end{bmatrix}$, this may be written as

$$\begin{aligned} \mathbf{u}_j^{(d)} = & (bp - cq + cr + bs) \left(\cos j\theta, \sin j\theta \right) \\ & + (cp + bq - br + cs) \left(-\sin j\theta, \cos j\theta \right) \\ & + (bp + cq + cr - bs) \left(\cos j\theta, -\sin j\theta \right) \\ & + (cp - bq - br - cs) \left(-\sin j\theta, -\cos j\theta \right). \end{aligned} \quad (1)$$

Since b and c are not both zero,

$$\det \begin{bmatrix} b & -c & c & b \\ c & b & -b & c \\ b & c & c & -b \\ c & -b & -b & -c \end{bmatrix} = (b^2 + c^2)^2 \neq 0,$$

so that, by suitable choice of values for p, q, r, s in the matrix, the coefficients in (5) can take any real values. We deduce that $\mathbf{U}^{O(n/d)}$ is spanned by the vectors $\mathbf{u}_1^{(d)}, \mathbf{u}_2^{(d)}, \mathbf{u}_3^{(d)}, \mathbf{u}_4^{(d)}$, where $\mathbf{u}_i^{(d)} = (u_{0,i}^{(d)}, \dots, u_{n-1,i}^{(d)})$ for $i = 1, 2, 3, 4$, and

$$\mathbf{u}_{j,1}^{(d)} = (\cos j\theta, \sin j\theta)$$

$$\mathbf{u}_{j,2}^{(d)} = (-\sin j\theta, \cos j\theta)$$

$$\mathbf{u}_{j,3}^{(d)} = (\cos j\theta, -\sin j\theta)$$

$$\mathbf{u}_{j,4}^{(d)} = (-\sin j\theta, -\cos j\theta).$$

It is easy to see that, except when $d = 0$ or $n = 2d$, these four vectors are linearly independent since they coincide with four vectors of the orthogonal basis of $\mathbf{V}(n)$ defined in Theorem 2. Hence the dimension of $\mathbf{U}^{O(n/d)}$ is 4. If $d = 0$ or if $n = 2d$, then $\mathbf{u}_1^{(d)} = \pm \mathbf{u}_3^{(d)}$ and $\mathbf{u}_2^{(d)} = \pm \mathbf{u}_4^{(d)}$; the dimension of $\mathbf{U}^{O(n/d)}$ in these cases is 2. \diamond

Moreover, we obviously have:

Corollary N2.1. If $n \neq 2d$, then

$$\mathbf{U}^{O(n/d)} = \mathbf{W}^{O(n/d)} \oplus \mathbf{W}^{O(n/(n-d))}$$

and hence, for all n and d , we have

$$\mathbf{V}^{(n/d)} = \mathbf{U}^{O(n/0)} \oplus \mathbf{U}^{O(n/1)} \oplus \mathbf{U}^{O(n/2)} \oplus \dots \oplus \mathbf{U}^{O(n/m)}$$

where $m = \lfloor n/2 \rfloor$.

Theorem N2.1 and its corollary also have geometric interpretations. From the first statement of Corollary N2.1 we have

Corollary N2.2. Every rooted affinely regular (n/d) -gon $\bar{Q} \in \mathcal{A}(n/d)$ which is not a point polygon can be represented uniquely as the vertex sum $\bar{R}_1 + \bar{R}_2$ where $\bar{R}_1 \in \mathcal{A}(n/d)$ and $\bar{R}_2 \in \mathcal{A}(n/(n-d))$ are regular polygons with the same center as \bar{Q} . Conversely, if $\bar{R}_1 \in \mathcal{A}(n/d)$ and $\bar{R}_2 \in \mathcal{A}(n/(n-d))$ then $\bar{R}_1 + \bar{R}_2$ is an affinely regular (n/d) -gon.

It is interesting to compare the above algebraic proof with the same result established by geometry. Since a regular polygon is inscribed in a circle and the image of a circle under an affine transformation is an ellipse or line segment or point, it follows that every non-degenerate affinely regular polygon is inscribed in an ellipse. Moreover, since the center of a polygon is mapped by any affine transformation into the vertex centroid of the image polygon, the circumscribed ellipse of a non-degenerate affinely regular polygon is centered at the vertex centroid of that polygon.

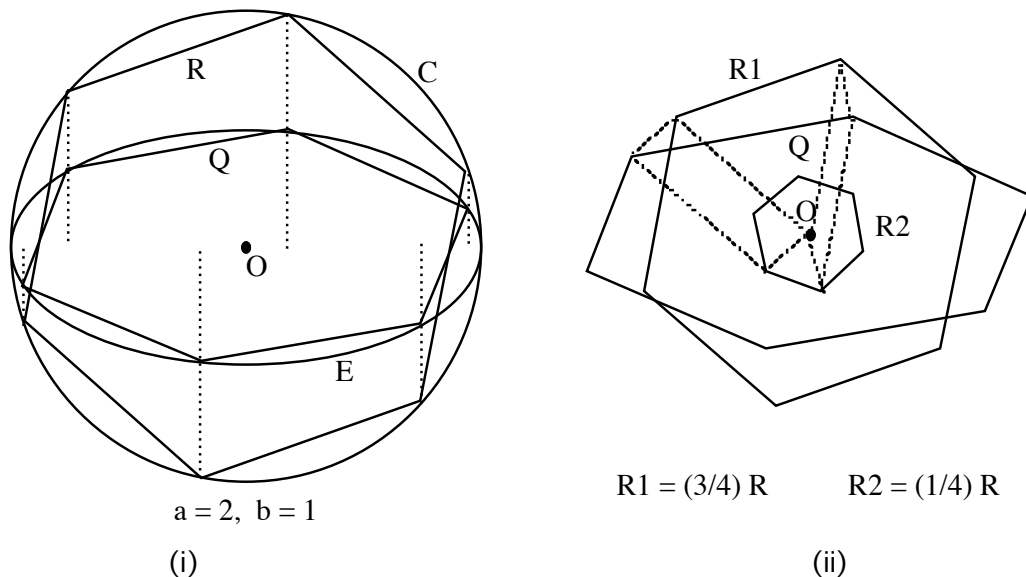

Figure N2.2. The construction, explained in the text, of two regular polygons whose vertex sum is the given affinely regular polygon.

Let E be the ellipse (or segment) into which Q is inscribed, which was obtained as the image of the circle circumscribing the regular polygon whose affine image is Q . Without loss of generality we assume that the origin O is the center of Q (and of E), and that the major axis of E is along the x -axis, see Figure N2.2. Let a and $b \leq a$ be the lengths of the two semi-axes of E . If C is a circle centered at O , with radius a , then there exists a regular polygon $R \in \lfloor (n/d) \rfloor$ inscribed in C such that the images of its vertices under orthogonal projection onto the x -axis coincide with the images of the vertices of Q , see Figure N2.2(i). Thus Q is obtained from R by the affine transformation in which each x coordinate is left unchanged and each y coordinate is multiplied by b/a . From this it is immediate that if we put $R_1 = \frac{a+b}{2a} R$ and $R_2 = \frac{a-b}{2a} R'$, where R' is obtained from R by reflection in the x -axis (so that $R' \in \lfloor (n/(n-d)) \rfloor$), then $Q = R_1 \oplus R_2$ see Figure N2.2(ii). Since the uniqueness is obvious, this completes the geometric proof of Corollary N2.2. Naturally, if $Q = R_1$ is itself a regular (n/d) -gon, then R_2 is the zero polygon.

The second statement of the Corollary N2.1 has a similar interpretation to that given above for regular polygons:

Corollary N2.3. Every rooted n -gon \bar{P}^O centered at the origin can be expressed uniquely as the vertex sum of $m = \lfloor n/2 \rfloor$ affinely regular polygons centered at the origin,

$$\bar{P}^O = \bar{A}^{O(n/1)} \oplus \bar{A}^{O(n/2)} \oplus \dots \oplus \bar{A}^{O(n/m)}. \tag{2}$$

In fact, using the notation of Corollary 2.1 we have

$$\bar{A}^{O(n/d)} = \bar{R}^{O(n/d)} \oplus \bar{R}^{O(n/n-d)} \text{ for } 1 \leq d < m,$$

and

$$\bar{A}^{O(n/m)} = \bar{R}^{O(n/m)} \text{ if } n = 2m \text{ is even.}$$

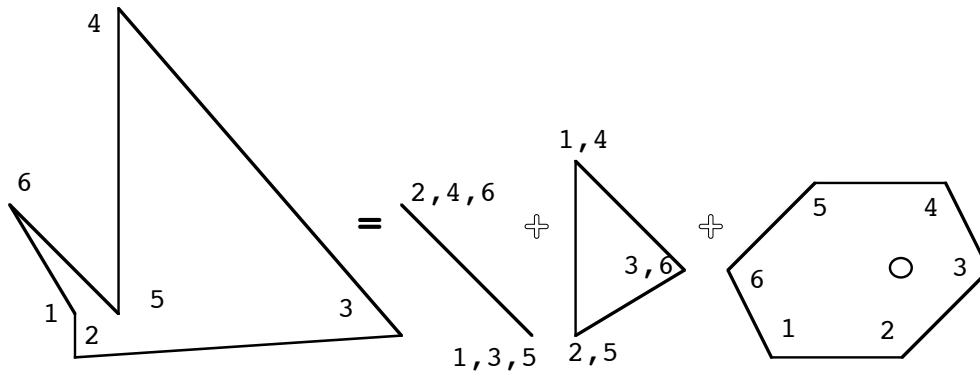

Figure N2.3. The decomposition of a hexagon into a vertex sum of three affinely regular hexagons, illustrating Corollary 3.3. For clarity, the origin has been moved away from the center of the hexagon that is being decomposed.

An illustration of the first statement of this corollary is given in Figure N2.3. The $\lfloor n/2 \rfloor$ polygons $A^{O(n/d)}$ are called the *affinely regular components* of P^O . A statement analogous to that of Corollary N1.1 can also be made, expressing an arbitrary n -gon as a vertex sum of $\lfloor n/2 \rfloor$ affinely regular n -gons and a point polygon. To simplify some of the later exposition, we introduce the following notation. If $0 \leq d \leq \lfloor n/2 \rfloor$, the affinely regular (n/d) -component of an n -gon P will be denoted $\alpha_{n,d}(P)$. Analogously, for $0 \leq d < n$, the regular (n/d) -component of the n -gon P will be denoted by $\beta_{n,d}(P)$.

It may be noted that in the representation (2) (as well as in (4) in Section N1) of an n -gon as the vertex sum of affinely regular (or regular) polygons, the signed area of the n -gon is equal to the sum of the signed areas of its affinely regular (or regular) components. To prove this we need the properties of regularizing vectors which will be developed in the next section.

We next discuss an affine characterization of affine-regular polygons, which is quite useful in several ways. It can be used, instead of the earlier arguments which relied on regular polygons and so were part of Euclidean geometry, for an affine proof of the fact that $\mathbf{U}^{O(n/d)}$, the set of all affinely regular (n/d) -gons centered at the origin, is a vector space.

Theorem N2.2. Let $P = [V_0, V_1, \dots, V_{n-1}]$ be an n -gon such that there exists a real number h with the property

$$v_{i+2} - v_{i-1} = h(v_{i+1} - v_i) \text{ for all } i = 0, 1, \dots, n-1.$$

Then either

- (i) P is a point polygon, or else
- (ii) $h = \frac{\sin 3\pi d/n}{\sin \pi d/n}$ for some d with $1 \leq d \leq \frac{n}{2}$, and P is an affine-regular (n/d) -gon.

Proof. Let P be an n -gon with the above property. The dimension of the convex hull of P is 0, 1 or 2. If it is 0, then P is a point polygon and there is nothing to prove. Otherwise, we first consider the case where the dimension is 2. We assume that $n \geq 6$, in order to avoid tedious special cases that arise due to the fact that for smaller values of n some of the vertices of P mentioned in the proof may coincide. We also assume that $h \neq 0$. The proof proceed in several steps, illustrated in Figure N2.4.

We first consider the line L_0 through the midpoint M_0 of the edge $[V_0, V_1]$ and the midpoint N_0 of the diagonal $[V_{n-1}, V_2]$ which is parallel to this edge. This is

illustrated in Figure N2.4(a). By applying — if necessary — a **shear** to P , we arrange that L_0 is perpendicular to $[V_0, V_1]$. Since shears are affine transformations, the ratios of the condition are unchanged; hence we henceforth assume that L_0 is perpendicular to $[V_0, V_1]$ for P itself.

With this assumption, the condition imposed in the theorem implies that the quadrangle $[V_1, V_0, V_{n-1}, V_{n-2}]$ is congruent to the quadrangle $[V_0, V_1, V_2, V_3]$ by reflection in L_0 , see Figure N2.4(b). We now apply a compression (or stretch) along L_0 , which leaves the line containing $[V_0, V_1]$ invariant, and makes the line L_1 determined by the midpoint M_1 of $[V_1, V_2]$ and the midpoint N_1 of $[V_0, V_3]$ perpendicular to $[V_1, V_2]$. Such a transformation is always possible since, by the triangle inequality, $h \leq 3$. Due to the mirror symmetry in L_0 , the same transformation makes the line L_{n-1} determined by the midpoints M_{n-1} and N_{n-1} of $[V_{n-1}, V_0]$ and $[V_{n-2}, V_1]$ perpendicular to these segments. Since all the transformations we have applied are affine, again there is no loss of generality in assuming that P has the properties just mentioned, see Figure N2.4(c).

The three lines L_{n-1}, L_0, L_1 are concurrent at some point O . As these lines are perpendicular bisectors of the sides $[V_{n-1}, V_0], [V_0, V_1], [V_1, V_2]$ of P , the six vertices $V_{n-2}, V_{n-1}, V_0, V_1, V_2, V_3$ are all concyclic on a circle C centered at O . In fact, since the ratio of $[V_0, V_3]$ to $[V_1, V_2]$ has the same value h as the ratio of $[V_{n-1}, V_2]$ to $[V_0, V_1]$, by elementary properties of the circle it follows that the edge $[V_1, V_2]$ has the same length as $[V_0, V_1]$.

Repeating the argument of the preceding paragraph for the line L_1 instead of L_0 , we see that the vertex V_4 is also on C , and, by congruence, the same follows for all other vertices of P . Since the chain of edges is finite, it must return to the starting vertex after a certain number d of circuits around C . It is then immediate that the conclusion of the theorem holds, and our proof is complete.

Our next goal is a generalization of Napoleon's theorem, due to A. Barlotti. We need some vocabulary and a lemma.

Given a segment $[A, B]$, we say that a rooted (n/d) -gon $P = [V_0, \dots, V_{n-1}]$ is *constructed over* $[A, B]$ if $V_0 = B$ and $V_1 = A$.

Lemma N2.1. For all n and d , if a rooted regular (n/d) -gon P_1 is constructed over a segment $[A, B]$ and a rooted regular (n/d) -gon P_2 is constructed over a segment $[C, D]$, then the rooted regular (n/d) -gon constructed over $[A+C, B+D]$ is $P_1 \oplus P_2$.

The lemma is illustrated in Figure N2.5. Its proof is immediate by using the similarity of the figures involved.

Theorem N2.3. (Napoleon-Barlotti) If $P = [V_0, V_1, \dots, V_{n-1}]$ is an oriented affinely regular (n/d) -gon, the centers of the regular (n/d) -gons constructed over the edges of P are the vertices of a regular (n/d) -gon $\mathcal{B}(P)$, and the centers of the regular $(n/(n-d))$ -gons constructed over the edges of P are the vertices of a regular $(n/(n-d))$ -gon $\mathcal{B}^*(P)$.

Three illustrations of the Napoleon-Barlotti theorem are shown in Figure N2.6.

Proof. Let $P = \beta_{n,d}(P) \oplus \beta_{n,n-d}(P)$ be the decomposition of P into its regular components, given by Corollary N2.2. Then each edge of P is the vertex sum (= vector sum) of the corresponding edges of the two regular polygons $R_1 = \beta_{n,d}(P)$ and

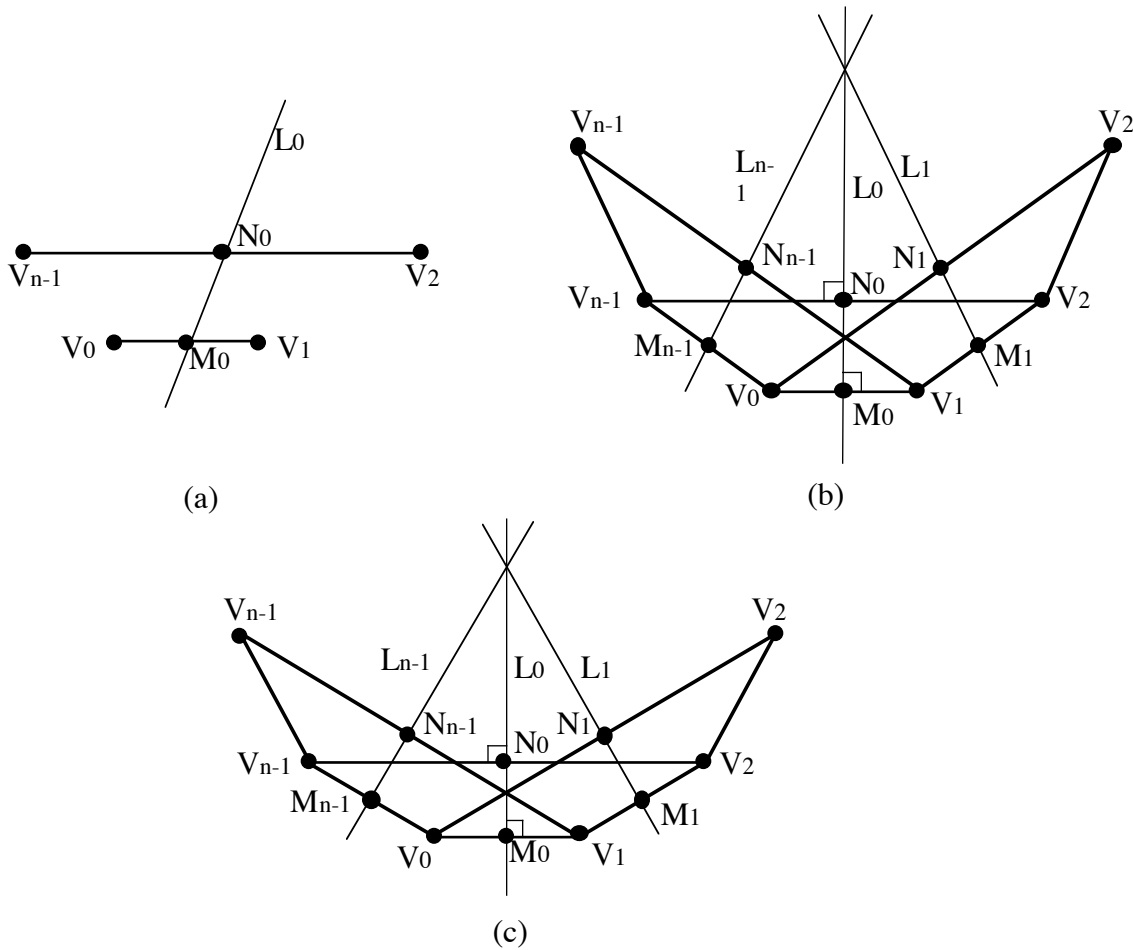

Figure N2.4. Illustration of the arguments used in the proof of Theorem N2.2.

$R_2 = \beta_{n,n-d}(P)$. By Lemma N2.1 the regular (n/d) -gons constructed over the edges of P are the vertex sums of the regular (n/d) -gons constructed over the corresponding edges of R_1 and R_2 ; therefore their centers (the vertices of $\mathcal{B}(P)$) are (vector) sums of the centers of the latter polygons. However, the centers of the regular (n/d) -gons constructed over the edges of R_1 clearly form a regular (n/d) -gon, while the centers of the regular (n/d) -gons constructed over the edges of R_2 all coincide with the center of R_2 , hence they form a point-polygon. Since the vertex sum of a regular (n/d) -gon and a point-polygon is a regular (n/d) -gon, the assertion concerning $\mathcal{B}(P)$ is proved. A completely analogous reasoning establishes the validity of the second part of the theorem. \diamond

The above proof establishes, in fact, a stronger result: The polygon $\mathcal{B}(P)$ is obtained from the regular (n/d) component $\beta_{n,d}(P)$ by a rotation through $\pi d/n$ and expansion by factor $2 \cos(\pi d/n)$, and the polygon $\mathcal{B}^*(P)$ is analogously obtained from $\beta_{n,n-d}(P)$ by rotation through $-\pi d/n$ and expansion by the same factor $2 \cos(\pi d/n)$. This

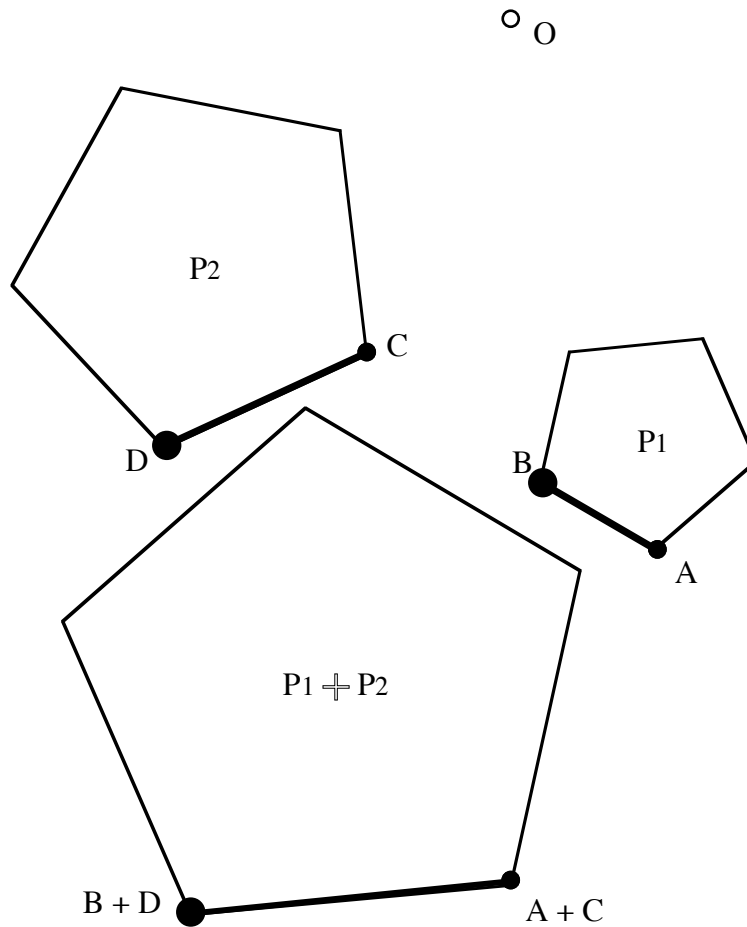

Figure N2.5. An illustration of Lemma N2.1.

is illustrated by the example in Figure N2.7.

Another illustration of the usefulness of the decomposition method is provided by the following result:

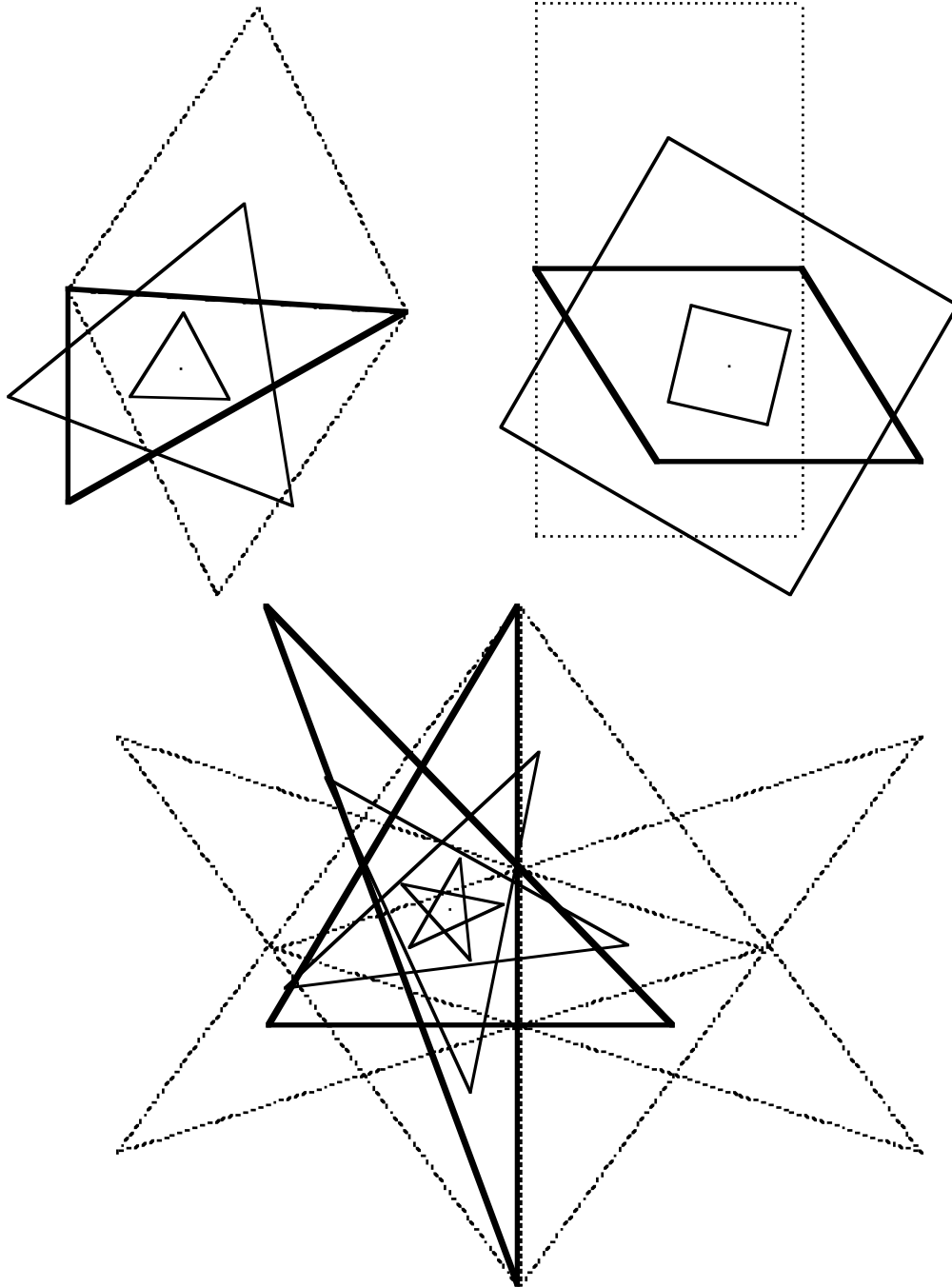

Figure N2.6. Three illustrations of the Napoleon-Barlotti theorem. The given affinely regular polygon P is shown by heavy lines, and the polygons $\mathcal{B}(P)$ and $\mathcal{B}^*(P)$ are shown by thin lines. The dotted lines indicate the regular polygons constructed on the edges of P ; to avoid clutter, only one such polygon is shown in each case.

Corollary N2.4. Let P be an arbitrary quadrangle, and let the quadrangle Q be formed by the centers of the regular $(4/1)$ -gons constructed on the edges of Q , and let R be the polygon having its vertices at the midpoints of the edges of Q . Then R is a square.

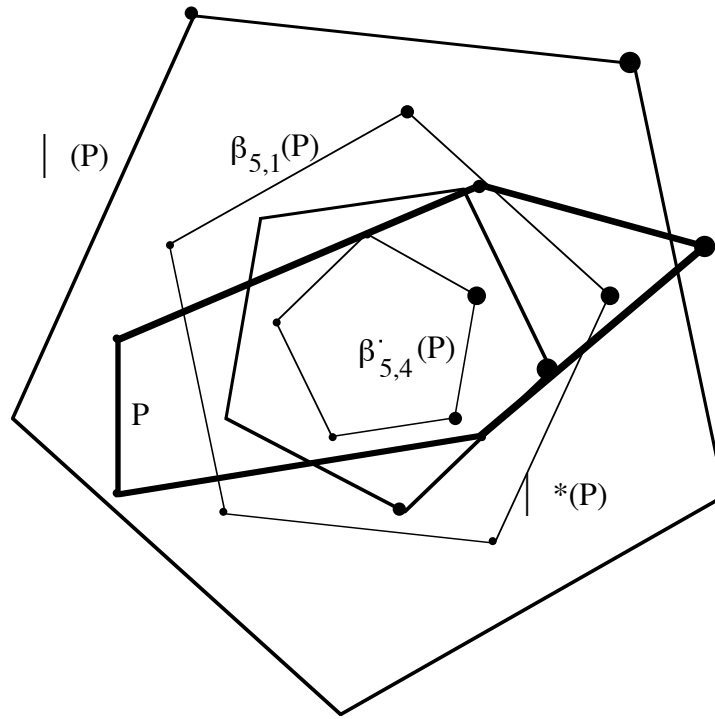

Figure N2.7. An illustration of the relationship between the regular components of an affinely regular polygon, and its Napoleon-Barlotti polygons.

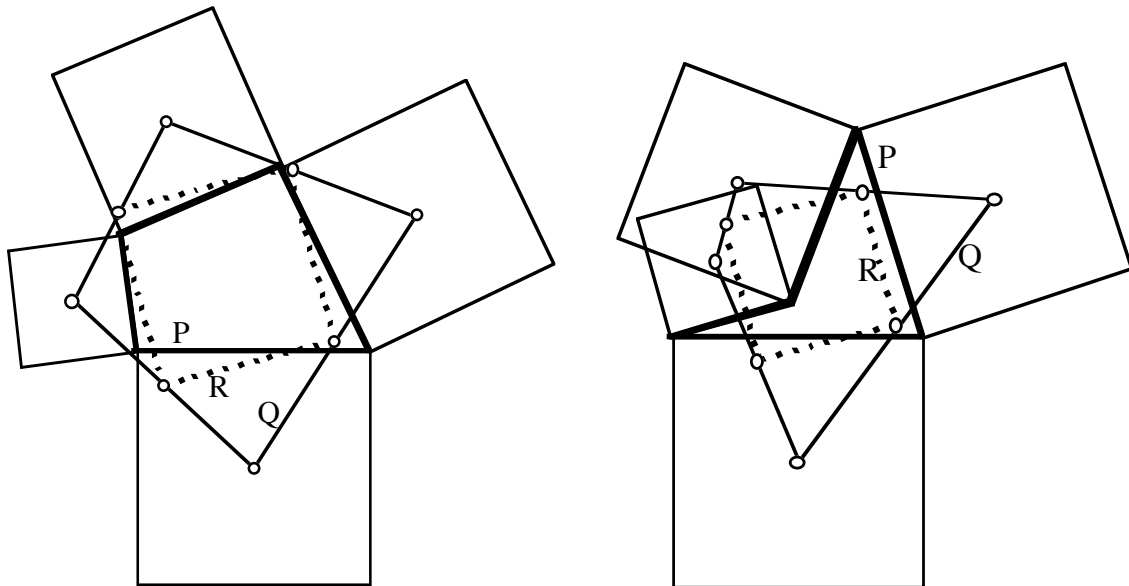

Figure N2.8. Starting from an arbitrary quadrangle P , the centers of the squares constructed on the edges of P are vertices of a quadrangle with the property that the midpoints of its edges are vertices of a square.

To prove Corollary N2.4 we recall that P is the vertex sum of its affinely regular components $\alpha_{4,1}(P)$ and $\alpha_{4,2}(P)$. By the Napoleon-Berlotti theorem, the centers of the squares constructed on the edges of $\alpha_{4,1}(P)$ form a square, and the midpoints of the edges of that square form clearly another square S . On the other hand, the midpoint of the squares constructed on the edges of $\alpha_{4,2}(P)$ form another regular $(4/2)$ -gon, and the midpoints of its edges form a point polygon. Hence R is a translate of S . \diamond

It may be observed that if the midpoint step in Corollary N2.4 is taken first, then a parallelogram is obtained (as is well known, and easily proved); the construction of squares on the sides of that parallelogram yields a square by the Napoleon-Berlotti theorem. As we shall see in the next section, the two operations commute for any polygon, hence this is an alternative proof of Corollary N2.4.

N3. Linear transformations; smoothing vectors

In this section we study operations on polygons by considering linear transformations on the vector space $\mathbf{V}(n)$ of vectors that represent the rooted polygons. We shall define several types of such transformations, show that they form easily characterized families, and determine some properties of these families. We shall also provide examples, and establish a number of results that will be used in the sequel. We begin with some simple observations, and introduce a number of concepts and appropriate notation.

Any linear transformation η on \mathbf{E}^2 induces a linear transformation (which we shall denote by the same symbol) on the space $\mathbf{V}(n)$ of vectors $\mathbf{v} = (v_0, \dots, v_{n-1})^T$ which represent rooted polygons by $\eta(\mathbf{v}) = (\eta(v_0), \dots, \eta(v_{n-1}))^T$.

If ζ is the linear transformation represented by the $n \times n$ permutation matrix $Z = (z_{jk})$, where

$$z_{jk} = \begin{cases} 1 & \text{if } k \equiv j+1 \pmod{n} \\ 0 & \text{otherwise} \end{cases}$$

and if $\mathbf{v} \in \mathbf{V}(n)$ represents a rooted polygon, then $\mathbf{v}^* = \zeta(\mathbf{v})$ represents the **same polygon** as \mathbf{v} but with a different choice of root. Consequently a linear transformation γ on $\mathbf{V}(n)$, which maps \mathbf{v} into $\mathbf{w} = \gamma(\mathbf{v})$, represents an operation on the (oriented but unrooted) **polygon** (in contrast to an operation on the **rooted polygon**) if and only if γ commutes with ζ (see Figure N3.1 for an illustration). As easily verified, the algebraic condition for this commutativity is that γ is represented by a **circulant matrix**, that is, a matrix in which each row is obtained from the one above it by a one-step shift to the right. Such a matrix is therefore completely determined by the vector $\mathbf{b} = (b_0, b_1, \dots, b_{n-1})$ of its first row. We shall use the notation

$$C(\mathbf{b}) = \begin{bmatrix} b_0 & b_1 & b_2 & \dots & b_{n-1} \\ b_{n-1} & b_0 & b_1 & \dots & b_{n-2} \\ b_{n-2} & b_{n-1} & b_0 & \dots & b_{n-3} \\ \vdots & \vdots & \vdots & \ddots & \vdots \\ b_1 & b_2 & b_3 & \dots & b_0 \end{bmatrix}.$$

Denoting by \mathbf{I} the $n \times n$ identity matrix, the matrix $C(\mathbf{b})$ may be written in the more convenient form

$$C(\mathbf{b}) = b_0\mathbf{I} + b_1Z + b_2Z^2 + \dots + b_{n-1}Z^{n-1}. \quad (1)$$

We refer to $\mathbf{b} = (b_0, b_1, \dots, b_{n-1})$ as a **smoothing vector**. Notice that if we use the representation of the vertices of P by complex numbers, then the above definition is applicable even if the b_j 's are complex numbers. As we shall see later, this turns out to

be very convenient in establishing results dealing with regular polygons. However, the real case is also of importance, especially concerning affine-regular polygons (see Theorem N3.1(vii) below).

It must be emphasized that since we are concerned with operations on the underlying polygons, we consider in this and several following section *only* linear transformations on $\mathbf{V}(n)$ of the type $C(b)$, that is, arising from smoothing vectors. We note that every n -dimensional vector b can serve as a smoothing vector in the definition of a smoothing transformation $S(b)$. The operation on the polygons that corresponds to a vector b is also denoted by $S(b)$ and is called a **smoothing operations**. If the rooted polygon Q is obtained in this manner from the rooted polygon P then we write $Q = S(b)P$. Further, by applying a smoothing operation to an oriented polygon but with two different vertices chosen as roots we obtain the same oriented polygon but with different roots. Hence a smoothing operation may be considered as acting on **oriented polygons**, as opposed to rooted polygons; we write $Q = S(b)P$ in this case as well.

The following are some elementary properties of the smoothing operations.

Theorem N3.1. (i) Two smoothing vectors represent the same smoothing operation on (unrooted) polygons if and only if the set of components of one of the vectors is a cyclic permutation of the components of the other.

(ii) The product $S(b)S(c)$ of two smoothing operations $S(b)$ and $S(c)$ is a smoothing operation $S(d)$, with $d_k = \sum_{j=0}^{n-1} b_j c_{k-j}$ for $k = 0, 1, \dots, n-1$, the subscripts being understood mod n .

(iii) Smoothing operations commute, that is, if b and c are smoothing vectors, then $S(b)S(c)P = S(c)S(b)P$ for all n -gons P .

(iv) If $\sum_{j=0}^{n-1} b_j = 1$, then the smoothed polygon $S(b)P$ has the same center (vertex centroid) as P ; conversely, if $S(b)P$ has the same center w as P then either w is the origin or else $\sum_{j=0}^{n-1} b_j = 1$.

(v) If $\sum_{j=0}^{n-1} b_j = 0$, then the smoothed polygon $S(b)P$ has its center at the origin; conversely, if $S(b)P$ has its center at the origin then either P has its center at the origin or else $\sum_{j=0}^{n-1} b_j = 0$.

(vi) If P is a regular (n/d) -gon, then for every smoothing vector b , $S(b)P$ is a regular (n/d) -gon.

(vii) If P is an affinely regular (n/d) -gon, then $S(b)P$ is an affinely regular (n/d) -gon for every smoothing vector b ; moreover, P and $S(b)P$ are inscribed in homothetic ellipses.

Proof Statement (i) is clear from the definitions, since a cyclic permutation of the components of a smoothing vector results in a corresponding change in the root vertex. (ii) is true because the product of two circulant $n \times n$ matrices is a circulant matrix, and (iii) is a consequence of the fact that $n \times n$ circulant matrices commute. These statements are immediate if we express circulant matrices in terms of powers of Z as in (1) and use $Z^n = \mathbf{I}$. Statements (iv) and (v) follow directly from the definitions. Statement (vi) is a consequence of the remarkable but easily verified fact (see, for example, P. J. Davis, *Circulant Matrices*. Wiley-Interscience, New York 1979, p. 73) that every $n \times n$ circulant matrix $C(b)$, where $b = (b_0, b_1, \dots, b_{n-1})$, has as eigenvectors the n complex vectors

$$\omega_d = (1, \omega^d, \omega^{2d}, \dots, \omega^{(n-1)d})^T,$$

where $d = 0, 1, \dots, n-1$, and $\omega = \exp(2\pi i/n)$; the corresponding eigenvalues are

$$c_d = \sum_{j=0}^{n-1} b_j \omega^{dj}.$$

It follows that every smoothing vector b acting on a standard regular (n/d) -gon $P = R_{n,d}$ yields a polygon P^* represented by $c_d \omega_d = c_d (1, \omega^d, \omega^{2d}, \dots, \omega^{(n-1)d})^T$; but this is precisely a general regular (n/d) -gon centered at the origin O . It is trivial to see that if P is, instead, a general regular (n/d) -gon centered at some point X , then its image under the smoothing operation $S(b)$ will also be a general regular (n/d) -gon centered at $C(b)X$. More precisely, denoting by $\rho_{b,d} = |c_d|$ and $\phi_{b,d} = \arg c_d$ the modulus (absolute value) and argument of c_d , so that $c_d = \rho_{b,d} \exp(i \phi_{b,d})$, we see that, in addition to the displacement of the center from X to $C(b)X$, P^* is obtained from P by expansion in ratio $\rho_{b,d}$ and rotation through angle $\phi_{b,d}$.

An alternative proof of (vi) follows geometrically from the fact that smoothing vectors do not **destroy symmetries**, so that if P is centered at the origin, then so is P^* , and every symmetry of P will be a symmetry of P^* , and conversely.

The first part of (vii) follows at once from (vi) and the decomposition result from Corollary N2.2. For the second part of (vii) note that if b is a vector with real components, then for each d

$$c_d = \sum_{j=0}^{n-1} b_j \omega^{dj} = \sum_{j=0}^{n-1} b_j \bar{\omega}^{(n-d)j} = \bar{c}_{n-d}.$$

Hence, if the regular (n/d) -component R_1 of the affinely regular n -gon P is expanded in ratio $\rho_{b,d}$ and turned through angle $\phi_{b,d}$ by a smoothing operation $S(b)$ with real b , then the regular $(n/(n-d))$ -component R_2 will be expanded in the same ratio $\rho_{b,d}$ and turned through $-\phi_{b,d}$, the same angle but in the opposite direction. It follows that the affine-regular polygon $P = R_1 \blackplus R_2$ and its image P^* under the smoothing operation $S(b)$ are inscribed in homothetic ellipses. We shall have occasion to apply this fact, and we shall refer to it by saying that P^* is obtained from P by **scaling** in ratio $\rho_{b,d}$ and an **affine-rotation** through angle $\phi_{b,d}$. \diamond

We note that the above interpretation of the eigenvectors of a circulant matrix as regular polygons immediately yields an alternative proof of part of Theorem N1.2, since a standard theorem of linear algebra tells us that if there are n distinct eigenvalues then a selection of corresponding eigenvectors forms a basis of the space.

Of particular interest are smoothing vectors that have special properties, and it is convenient to distinguish the following types:

(I) Vectors b such that $S(b)P$ is an affine-regular (n/d) -gon for every n -gon P are called **(n/d) -regularizing** vectors. The set of all (n/d) -regularizing vectors will be denoted by $\mathbf{R}(n/d)$. Vectors b such that $S(b)P$ is a regular (n/d) -gon for every n -gon P are called **strictly (n/d) -regularizing**; their totality is denoted by $\mathbf{R}^*(n/d)$. As we shall see later, every strictly (n/d) -regularizing vector must have some components which are complex numbers.

(II) Vectors b such that, for given n and d , if P is any affine-regular (n/d) -gon, then $S(b)P$ is a point polygon are called **(n/d) -dotting** vectors (for they map each such polygon P into a dot!), and the set of all such vectors will be denoted by $\mathbf{D}(n/d)$.

Two subsets of $\mathbf{D}(n/d)$ are of special interest:

(IIa) The set of vectors b in $\mathbf{D}(n/d)$ such that, for every affine-regular (n/d) -gon P , the image $S(b)P$ is a point polygon which coincides with the center of P . These vectors are called **(n/d) -centralizing** vectors, and the set of all such vectors is denoted by $\mathbf{C}(n/d)$. By Theorem N3.1(iv) the set $\mathbf{C}(n/d)$ coincides with the set of vectors b that satisfy $\sum_{j=0}^{n-1} b_j = 1$.

(IIb) The set of vectors \mathbf{b} in $\mathbf{D}(n/d)$ such that $S(\mathbf{b})P$ is the zero polygon for every affine-regular (n/d) -gon P . These are called **(n/d) -annihilating** vectors, and the set of all such is denoted by $\mathbf{A}(n/d)$. By Theorem N3.1(v) these are precisely the vectors that satisfy $\sum_{j=0}^{n-1} b_j = 0$.

The use of outline letters $\mathbf{R}(n/d)$, $\mathbf{R}^*(n/d)$, $\mathbf{D}(n/d)$, $\mathbf{C}(n/d)$ and $\mathbf{A}(n/d)$ for the above sets anticipates the fact that, as we shall show later, each of these is a vector or affine subspace of the vector space $\mathbf{S}(n)$ of all smoothing vectors for n -gons. Before we start a systematic study of smoothing vectors, we give simple examples that show the existence of vectors of each of the above types.

Examples N3.1. (i) The existence of (n/d) -regularizing vectors (Type I) for some small values of n is illustrated by the following examples, adapted from the literature; see Figure N3.2. In each case, $P \in \mathcal{A}(n)$ represents an arbitrary n -gon in the plane. For $n = 4$ let $\mathbf{b} = (1, 1, 0, 0)$; then $S(\mathbf{b})P$ is a parallelogram, that is, an affine-regular 4-gon; this is the "midpoint map", which we shall investigate in detail later. If, for $n = 5$, we take $\mathbf{b} = (1, \tau, 1, 0, 0)$ where $\tau = (1 + \sqrt{5})/2 = 1.618034\dots$, then $S(\mathbf{b})P$ is an affine-regular pentagon, and if $\mathbf{b} = (1, 1-\tau, 1, 0, 0)$, then $S(\mathbf{b})P$ is an affine-regular pentagon. If, for $n = 6$, we take $\mathbf{b} = (-1, 0, 2, 3, 2, 0)$ or $\mathbf{b} = (1, 2, 2, 1, 0, 0)$ then, in either case, $S(\mathbf{b})P$ will be an affine-regular hexagon. We shall return to these and other examples in a later section. Below we shall give several characterizations of (n/d) -regularizing vectors, and describe various families of such vectors.

(ii) It can be easily verified that $\mathbf{b} = (1-i, -1-i, -1+i, 1+i)/2$ is a strictly $(4/1)$ -regularizing vector, and that $\mathbf{b} = (3-i\sqrt{3}, -2i\sqrt{3}, -3-i\sqrt{3}, -3+i\sqrt{3}, 2i\sqrt{3}, 3+i\sqrt{3})/12$ is a strictly $(6/1)$ -regularizing vector; see Figure N3.3.

(iii) To find examples of centralizing vectors (Type IIa) we observe that if $\theta = 2\pi d/n$, every three consecutive vertices V_r, V_{r+1}, V_{r+2} of a regular (n/d) -gon P centered at X satisfy

$$\frac{1}{2}(v_r + v_{r+2}) = y = (\cos \theta)v_{r+1} + (1 - \cos \theta)x, \quad (2)$$

see Figure N3.4; since affinities preserve ratios of collinear segments, this relation holds for affine-regular (n/d) -gons as well. Hence

$$\frac{1}{2}(1 - \cos \theta)^{-1}(v_r - (2 \cos \theta)v_{r+1} + v_{r+2}) = x.$$

It follows that if $\mathbf{b}^{(1)}$ is the smoothing vector

$$b^{(1)} = \frac{1}{2}(1 - \cos \theta)^{-1}(1, -2 \cos \theta, 1, 0, 0, \dots, 0),$$

then $S(b^{(1)})P$ is a degenerate (n/d) -gon (point polygon) coinciding with the center X of P . Thus $b^{(1)}$ is an (n/d) -centralizing vector.

If b is any (n/d) -centralizing vector, then it is easy to see that any scalar multiple of b is an (n/d) -dotting vector (Type II).

(iv) To obtain examples of annihilating vectors (Type IIb) we use the fact that if Q is a point polygon, and $b^{(0)}$ is the vector $(1, -1, 0, 0, \dots, 0)$, then $S(b^{(0)})Q$ is the zero polygon. It follows that if b is any (n/d) -dotting vector, then $S(b^{(0)})S(b)$ is the smoothing operation arising from an (n/d) -annihilating vector. In particular, using a multiple of the (n/d) -centralizing vector $b^{(1)}$ in (iii), we have

$$C(b^{(0)}) = I - Z, \quad C(b^{(1)}) = I - (2 \cos \theta)Z + Z^2$$

and so

$$\begin{aligned} C(b^{(0)})C(b^{(1)}) &= (I - Z)(I - (2 \cos \theta)Z + Z^2) \\ &= I - hZ + hZ^2 - Z^3 \end{aligned}$$

where $h = 1 + 2 \cos \theta$ and $\theta = 2\pi d/n$. It follows that

$$b^{(2)} = (1, -h, h, -1, 0, 0, \dots, 0)$$

is an (n/d) -annihilating vector.

We formalize part of the above discussion in the following useful criteria for affine-regularity.

Theorem N3.2. Let $P \in \mathcal{A}(n)$ be represented by the vector $v \in \mathbf{V}(n)$, and let $\theta = 2\pi d/n$ and $h = 1 + 2 \cos \theta$. Then the following are equivalent:

- (i) P is an affine-regular (n/d) -gon (possibly a point polygon);
- (ii) The vector $b^{(1)} = \frac{1}{2}(1 - \cos \theta)^{-1}(1, -2 \cos \theta, 1, 0, 0, \dots, 0)$ centralizes P ;
- (iii) The vector $b^{(2)} = (1, -h, h, -1, 0, 0, \dots, 0)$ annihilates P .

This leads to the following relationships between the spaces $\mathbf{R}(n/d)$ and $\mathbf{A}(n/d)$:

Corollary N3.3. If b^* is any (n/d) -annihilating vector (Type IIb), then b is an (n/d) -regularizing vector if and only if $S(b)S(b^*)P = S(b^*)S(b)P$ is the zero polygon for every n -gon P .

Equivalently, the condition can be stated as $C(b)C(b^*) = C(b^*)C(b) = O$ (the zero matrix), or that

$$\mathbf{b}^* \cdot \tilde{\mathbf{b}} = \tilde{\mathbf{b}} \cdot \mathbf{b}^* = 0 \quad (3)$$

where $\tilde{\mathbf{b}}$ denotes the vector obtained by reversing the order of the components in \mathbf{b} , and the dot \cdot denotes the usual scalar product.

We now establish the results about $\mathbf{R}(n/d)$, $\mathbf{D}(n/d)$, $\mathbf{C}(n/d)$ and $\mathbf{A}(n/d)$ indicated above.

Theorem N3.4. The sets

- (i) $\mathbf{R}(n/d)$ of all (n/d) -regularizing vectors,
- (ii) $\mathbf{D}(n/d)$ of all (n/d) -dotting vectors, and
- (iii) $\mathbf{A}(n/d)$ of all (n/d) -annihilating vectors,

are vector subspaces of the vector space $\mathbf{S}(n)$ of all smoothing vectors. On the other hand, the set

- (iv) $\mathbf{C}(n/d)$ of all (n/d) -centralizing vectors is an affine subspace of $\mathbf{S}(n)$.

Proof For a direct proof of (i), suppose $\mathbf{b}^{(3)}$ and $\mathbf{b}^{(4)}$ are (n/d) -regularizing vectors, and $\mathbf{b}^{(2)}$ is the (n/d) -annihilating vector that appears in Theorem N3.2; then for all real numbers λ and μ , and all n -gons P ,

$$\begin{aligned} S(\lambda\mathbf{b}^{(3)} + \mu\mathbf{b}^{(4)})S(\mathbf{b}^{(2)})P &= (\lambda S(\mathbf{b}^{(3)}) + \mu S(\mathbf{b}^{(4)}))S(\mathbf{b}^{(2)})P \\ &= \lambda S(\mathbf{b}^{(3)})S(\mathbf{b}^{(2)})P + \mu S(\mathbf{b}^{(4)})S(\mathbf{b}^{(2)})P \end{aligned}$$

which is the zero polygon. Hence $\lambda\mathbf{b}^{(3)} + \mu\mathbf{b}^{(4)}$ is an (n/d) -regularizing vector. This shows that all such vectors form a vector space (obviously a vector subspace of $\mathbf{S}(n)$).

An alternative proof follows from the results of Section 2. One way is to invoke Theorem N2.2 which characterizes affine-regular polygons and is clearly comparable with linear combinations. Another possibility is to recall that all affine-regular (n/d) -gons form a vector space, and that the set of all linear maps from a vector space into a vector space is itself a vector space.

For (ii) and (iii) we observe that for all λ and μ , and all affine-regular (n/d) -gons P , if $\mathbf{b}^{(3)}$ and $\mathbf{b}^{(4)}$ are (n/d) -dotting, or (n/d) -annihilating vectors, then $S(\lambda\mathbf{b}^{(3)} + \mu\mathbf{b}^{(4)})P = \lambda S(\mathbf{b}^{(3)})P + \mu S(\mathbf{b}^{(4)})P$ is a point polygon, or the zero polygon, respectively. Hence each of the sets $\mathbf{D}(n/d)$ and $\mathbf{A}(n/d)$ is a vector space.

Finally, for (iv) an analogous argument holds for centralizing vectors except that here we must specify $\lambda + \mu = 1$. Thus the set $\mathbf{C}(n/d)$ of all centralizing vectors forms an affine subspace of $\mathbf{S}(n)$. \diamond

We shall now investigate the spaces $\mathbf{R}(n/d)$, $\mathbf{D}(n/d)$, $\mathbf{C}(n/d)$ and $\mathbf{A}(n/d)$ in some detail; in particular we shall determine their dimensions and find bases for them. But first we give another method of generating regularizing vectors. A similar discussion of $\mathbf{R}^*(n/d)$ will come later.

Theorem N3.5. Let $R = [V_0, \dots, V_{n-1}]$ be a regular (n/d) -gon and let a be any vector. Then, denoting by \cdot the dot product of vectors, $b = (a \cdot v_0, \dots, a \cdot v_{n-1})$ is an (n/d) -regularizing vector, $b \in \mathbf{R}(n/d)$.

Proof The result is trivial if $a = 0$, so assume that $a \neq 0$. We write $a = a_1 e_x + a_2 e_y$ where a_1, a_2 are the components of a , and e_x, e_y are unit vectors parallel to the x - and y -axes respectively. Then the theorem is clearly true if we can prove it when each of e_x and e_y is substituted for a .

Further, let $c = (c_1, c_2)$ be the center of R , and r be its circumradius. Then, for suitable α and $\theta = 2\pi d/n$, the vertex V_j of R is specified by

$$v_j = (c_1 + r \cos(\alpha + j\theta), \quad c_2 + r \sin(\alpha + j\theta)).$$

Thus

$$e_x \cdot v_j = c_1 + r \cos(\alpha + j\theta), \quad e_y \cdot v_j = c_2 + r \sin(\alpha + j\theta)$$

and therefore, by Theorem N3.1 it is sufficient to show that

$$(c_1 + r \cos(\alpha + j\theta)) - h((c_1 + r \cos(\alpha + (j+1)\theta)) + h((c_1 + r \cos(\alpha + (j+2)\theta)) - (c_1 + r \cos(\alpha + (j+3)\theta)))) = 0,$$

and a similar equation with c_2 substituted for c_1 and each cosine replaced by the corresponding sine, are both satisfied; here, as before, $h = 1 + 2 \cos \theta$ and $\theta = 2\pi d/n$. However, each of these equalities is an immediate consequence of well-known trigonometric identities. \diamond

Some special cases of Theorem N3.5 are of interest. The first will be of importance later.

Corollary N3.6 Let

$$c(n, d) = \frac{1}{n} (1, \cos \theta, \cos 2\theta, \dots, \cos (n-1)\theta)$$

and

$$s(n, d) = \frac{1}{n} (0, \sin \theta, \sin 2\theta, \dots, \sin (n-1)\theta)$$

where $\theta = 2\pi d/n$. Then $c(n, d)$ and $s(n, d)$ are (n/d) -regularizing vectors for every value of n and d . In particular, if n is even then

$$c(n, \frac{1}{2}n) = \frac{1}{n} (1, -1, 1, -1, \dots, 1, -1)$$

is an $(n/\frac{1}{2}n)$ -regularizing vector, and, whether n be even or odd,

$$c(n, 0) = \frac{1}{n} (1, 1, 1, \dots, 1)$$

is an $(n/0)$ -centralizing vector, for every value of d and n .

Proof To show $c(n, d)$ is an (n/d) -regularizing vector we take $a = e_x$, $c_1 = 0$, $r = 1/n$, $\alpha = 0$ in the proof of Theorem N3.5. To show $s(n, d)$ is an (n/d) -regularizing vector we take $a = e_y$, $c_2 = 0$, $r = 1/n$, $\alpha = 0$. The other assertions follow trivially.

Note that if $d \neq 0$, then both $c(n, d)$ and $s(n, d)$ are vectors of type (i) in Theorem N3.4, and $c(n, 0)$ is a vector of type (iv).

The vectors $c(n, d)$ have several interesting properties, such as the following which we shall use later.

Corollary N3.7. Let $u = (1, 0, 0, 0, \dots, 0)$ be the n -vector whose components are all zero except for the first which is 1, and let $e(n, d) = 1$ if $d = 0$ or $n/2$ (n even), and $e(n, d) = 2$ in all other cases. Then, putting $m = [n/2]$, we have

$$\sum_{d=0}^m e(n, d) c(n, d) = u.$$

Proof. From the definition of the vectors $c(n, d)$ in Corollary N3.6, and since $\cos j\theta = \cos (n-j)\theta$ for $\theta = 2\pi d/n$, the j^{th} component of $\sum_{d=0}^m e(n, d) c(n, d)$ is easily seen to be

$$\frac{1}{n} \sum_{d=0}^{n-1} \cos jd\theta = \begin{cases} 1 & \text{if } j = 0 \\ 0 & \text{if } j \neq 0 \end{cases}.$$

This follows by standard trigonometric relations, or by considering the vertex centroid of a regular n -gon, one vertex of which is at the point $(1, 0)$. \diamond

As other examples of regularizing vectors we have:

Corollary N3.8. Let $A = [V_0, \dots, V_{n-1}]$ be a (non-degenerate) regular or affine-regular (n/d) -gon and let the (non-zero) vector $f(n, d) = (f_0, \dots, f_{n-1})$ be defined by $f_j(v_0 - v_{n-1}) = f_0(v_j - v_{n-j-1})$, where $f_0 \neq 0$ is arbitrary. Then f is an (n/d) -regularizing vector.

Proof Since the ratios of lengths in parallel directions are unchanged by an affine transformation, there is no loss of generality in assuming that A is regular (and not just affine-regular) and that A is centered at the origin. Thus f_0, \dots, f_{n-1} are the lengths of the diagonals (preceded by a $+$ or $-$ sign) of a regular (n/d) -gon. If the circumradius of this n -gon is r_1 then we obtain the values $f_j = 2r_1 \sin(\frac{1}{2} + j)\theta$, where $\theta = 2\pi d/n$ (see Figure N3.6). The fact that f is a regularizing (n/d) -vector then follows from the proof of Theorem N3.5, with $a = e_y$, $c_2 = 0$, $r = 2r_1$, and $\alpha = \theta/2$. \diamond

Examples N3.2. From Corollary N3.8, taking $f_0 = 1$, we obtain the regularizing vectors $f(4, 1) = (1, 1, -1, -1)$, $f(5, 1) = (1, \tau, 0, -\tau, -1)$ (where τ is the golden section constant $(1 + \sqrt{5})/2 = 1.6180340\dots$), $f(5, 2) = (1, 1-\tau, 0, \tau-1, -1)$, $f(6, 1) = (1, 2, 1, -1, -2, -1)$, and so on (see Figure N3.5).

It is worth noting that the constant h of Theorem N3.2 is equal to f_1 / f_0 .

Theorem N3.9. For $1 \leq d < [n/2]$, the vector space $\mathbf{R}(n/d)$ of (n/d) -regularizing vectors is three-dimensional. For even n and $d = n/2$, the vector space $\mathbf{R}(n/d)$ is two-dimensional.

Proof. We consider first the case $d \neq n/2$. By Corollary N3.3, if b is any (n/d) -regularizing vector, then, from condition (3),

$$b_{j+3} - hb_{j+2} + hb_{j+1} - b_j = 0$$

for $j = 0, \dots, n-1$. Setting $A = \mathbf{I} - hZ + hZ^2 - Z^3$, this system of equations may be written as $A b = 0$ and we require the set of solutions of these equations (the null-space of A). The $n \times n$ matrix of coefficients A is a circulant matrix, so we consider the polynomial whose coefficients are the elements of the first row:

$$g(h, x) = 1 - hx + hx^2 - x^3 = (1 - x)(\omega^d - x)(\omega^{-d} - x)$$

where $\omega = \exp(2\pi i/n)$. A well-known theorem (see, for example P. J. Davis, *Circulant Matrices*. Wiley-Interscience, New York 1979, p.73; P. Lancaster, *Theory of Matrices*.

Academic Press, New York and London, 1969) tells us that the eigenvalues of A are the values of $g(h, x)$ when $x = 1, \omega, \omega^2, \dots, \omega^{n-1}$. Since g is of degree 3 in x , we deduce that $n - 3$ of these eigenvalues are non-zero, so the rank of A is at least $n - 3$.

On the other hand, there are three linearly independent solutions for b , namely

$$(1, \lambda, \lambda^2, \dots, \lambda^{n-1}) \quad \text{for } \lambda = 1, \omega^d, \omega^{-d}.$$

Hence the solutions form a vector space $\mathbf{R}(n/d)$ of dimension three.

In the present context it is preferable to find a real basis. This can be done by taking real and imaginary parts of the last two vectors, together with the first, to obtain the basis $\{c(n, d), s(n, d), c(n, 0)\}$ where

$$\left. \begin{aligned} c(n, d) &= \frac{1}{n} (1, \cos \theta, \cos 2\theta, \dots, \cos (n-1)\theta) \\ s(n, d) &= \frac{1}{n} (0, \sin \theta, \sin 2\theta, \dots, \sin (n-1)\theta) \\ c(n, 0) &= \frac{1}{n} (1, 1, 1, \dots, 1) \end{aligned} \right\}, \tag{4}$$

with $\theta = 2\pi d/n$. (These are the vectors that were introduced in Corollary N3.6.)

When n is even and $d = n/2$, similar considerations hold with $h = -1$. Then

$$g(-1, x) = 1 + x - x^2 - x^3 = (1 - x)(1 + x)^2,$$

and there are $n - 2$ non-zero eigenvalues, so $\mathbf{R}(n/d)$ is two dimensional and a basis is $\{c(n, \frac{1}{2}n), c(n, 0)\}$. \diamond

Example N3.3. We note that in the case $d \neq n/2$, yet another basis of $\mathbf{R}(n/d)$ is

$$\begin{aligned} f^{(1)}(n, d) &= (f_0, f_1, f_0 + f_2, f_1 + f_3, f_0 + f_2 + f_4, \\ &\quad f_1 + f_3 + f_5, f_0 + f_2 + f_4 + f_6, \dots, 0, 0), \tag{5} \\ f^{(2)}(n, d) &= (0, f_0, f_1, f_0 + f_2, f_1 + f_3, f_0 + f_2 + f_4, \dots, 0), \\ f^{(3)}(n, d) &= (0, 0, f_0, f_1, f_0 + f_2, f_1 + f_3, f_0 + f_2 + f_4, \dots), \end{aligned}$$

where the f_j are defined as in Corollary N3.8 (using the diagonals of a non-degenerate (n/d) -gon). Trigonometric identities ensure that $f^{(2)}(n, d)$ is in $\mathbf{R}(n/d)$, and that it is palindromic, that is, reads the same backwards as forwards; $f^{(1)}(n, d)$ and $f^{(3)}(n, d)$ are obtained from $f^{(2)}(n, d)$ by shifting the components one place to the left or right, respectively. Since they are obviously linearly independent, the three vectors form a basis for $\mathbf{R}(n/d)$.

As a numerical example, consider the case $n = 6$. For $d = 1$, from Example N3.2 we see that we may take $f(6, 1) = (1, 2, 1, -1, -2, -1)$, so that the resulting basis vectors of $\mathbf{R}(6/1)$ are $f^{(1)}(6, 1) = (1, 2, 2, 1, 0, 0)$, $f^{(2)}(6, 1) = (0, 1, 2, 2, 1, 0)$ and $f^{(3)}(6, 1) = (0, 0, 1, 2, 2, 1)$. For $d = 2$ we may take $f(6, 2) = (1, 0, -1, 1, 0, -1)$ and obtain $f^{(1)}(6, 2) = (1, 0, 0, 1, 0, 0)$, $f^{(2)}(6, 2) = (0, 1, 0, 0, 1, 0)$ and $f^{(3)}(6, 2) = (0, 0, 0, 1, 0, 0, 1)$ as basis vectors of $\mathbf{R}(6/2)$. For $d = 3$ as the two basis vectors of $\mathbf{R}(6/3)$ we may take $f^{(1)}(6, 3) = (1, 0, 1, 0, 1, 0)$ and $f^{(2)}(6, 3) = (0, 1, 0, 1, 0, 1)$.

By the above results, we have defined two bases for $\mathbf{R}(n/d)$ ($d \neq n/2$), namely $\{c(n, d), s(n, d), c(n, 0)\}$ in the proof of Theorem N3.9 (see (4)) and $f^{(i)}(n, d)$ (for $i = 1, 2, 3$) by relations (5) in Example N3.3. By using routine trigonometric relations, it can be seen that these bases are related in the following manner (where $\theta = 2\pi d/n$):

$$f(n, d) = f^{(1)}(n, d) - f^{(3)}(n, d) = n (c(n, d) + \cot(\theta/2)s(n, d)),$$

$$f^{(2)}(n, d) = \frac{n}{2} \left((\cos \theta - 1)^{-1}(c(n, d) - c(n, 0)) + \operatorname{cosec} \theta s(n, d) \right),$$

$$c(n, d) = \frac{1}{n} \left(f^{(1)}(n, d) - (1 + \cos \theta)f^{(2)}(n, d) + \cos \theta f^{(3)}(n, d) \right).$$

$$s(n, d) = \frac{1}{n} \sin \theta \left(f^{(2)}(n, d) - f^{(3)}(n, d) \right)$$

$$c(n, 0) = \frac{1}{n} \left(f^{(1)}(n, d) - 2 \cos \theta f^{(2)}(n, d) + f^{(3)}(n, d) \right).$$

Theorem N3.10. Except when n is even and $d = n/2$, the vector space $\mathbf{A}(n/d)$ of (n/d) -annihilating vectors has dimension $n - 3$. If $n = 2d$, the dimension of $\mathbf{A}(n/d)$ is $n - 2$.

Proof If $d \neq n/2$, we know from Theorem N3.9 that the dimension of $\mathbf{R}(n/d)$ is 3 and from Corollary N3.3 that $\mathbf{R}(n/d)$ and $\mathbf{A}(n/d)$ are orthogonal complements in $\mathbf{S}(n)$, the n -dimensional vector space of all smoothing vectors of n -gons. We deduce that in this case the dimension of $\mathbf{A}(n/d)$ is $(n - 3)$. Recalling that if n is even, the dimension of $\mathbf{R}(n / \frac{1}{2} n)$ is 2, the fact that the dimension of $\mathbf{A}(n / \frac{1}{2} n)$ is $n - 2$ follows in a similar manner. \diamond

Examples N3.4. It is of some interest to find a basis of $\mathbf{A}(n/d)$ in each case. If $d < n/2$ we may take the $n - 3$ vectors:

$$(0^j, 1, -h, h, -1, 0^{n-j-4}) \text{ for } j = 0, 1, \dots, n - 4$$

where, as usual, 0^j signifies that the non-zero terms $1, -h, h, -1$ are to be preceded by j zeros, and 0^{n-j-4} means that they are to be followed by $n-j-4$ zeros. Here $\theta = 2\pi d/n$ and $h = 1 + 2 \cos \theta$. It is clear that these vectors are linearly independent and so form a basis of $\mathbf{A}(n/d)$. In the case where $n = 2d$ is even, the $n-2$ vectors:

$$(0^j, 1, 0, -1, 0^{n-j-3}) \text{ for } j = 0, 1, \dots, n-3$$

form a basis of $\mathbf{A}(n, \frac{1}{2}n)$.

Theorem N3.11. Except when n is even and $d = n/2$ the affine space $\mathbf{C}(n/d)$ of (n/d) -centralizing vectors has affine dimension $(n-3)$. In the exceptional case, the dimension of $\mathbf{C}(n/\frac{1}{2}n)$ is $n-2$.

Proof We recall that $c(n, 0) = \frac{1}{n}(1, 1, 1, \dots, 1) \in \mathbf{C}(n/d)$. Thus if $b \in \mathbf{C}(n/d)$ then $S(b) = S(c(n, 0))$ and so $b - c(n, 0)$ is an (n/d) -annihilating vector. It follows that $\mathbf{C}(n/d)$ is a translate of $\mathbf{A}(n/d)$ by the vector $c(n, 0)$. Thus the affine space $\mathbf{C}(n/d)$ has the same dimension as $\mathbf{A}(n/d)$ and the results follow immediately from Theorem N3.10.

Theorem N3.12. Except when n is even and $d = n/2$ the affine space $\mathbf{D}(n/d)$ of (n/d) -centralizing vectors has affine dimension $(n-2)$. In the exceptional case, the dimension of $\mathbf{D}(n/\frac{1}{2}n)$ is $n-1$.

Proof To determine the dimensions of the spaces $\mathbf{D}(n/d)$ we proceed as follows. We begin with a geometric method of finding the affine-regular (n/d) -gon that results from applying an arbitrary smoothing operation to an affine-regular (n/d) -gon (compare with statement (vii) of Theorem N3.1).

Let u_i represent the unit vector $(\cos j\theta, \sin j\theta)$ where $\theta = 2\pi d/n$ and $j = 0, 1, \dots, n-1$. Then the vertices of a regular (n/d) -gon $P = [V_0, \dots, V_{n-1}]$, centered at the point with position vector c , and of radius r , have position vectors

$$v_i = c + ru_i \quad (i = 0, 1, \dots, n-1).$$

Therefore, if $b = (b_0, \dots, b_{n-1})$ then $S(b)P$ is the polygon $P^* = [W_0, \dots, W_{n-1}]$ where

$$w_j = \left(\sum_{k=0}^{n-1} b_k \right) c + r(b_{n-j}u_0 + b_{1-j}u_1 + b_{2-j}u_2 + \dots + b_{n-1-j}u_{n-1}).$$

Here, as always, subscripts k are reduced modulo n so they lie in the range $0 \leq k \leq n-1$. Now let

$$t(n, d) = b_0u_0 + b_1u_1 + \dots + b_{n-1}u_{n-1}, \quad (6)$$

If the vector $s(n, d)$ is obtained from the unit vector $u_0 = (1, 0)$ by a rotation ϕ and an expansion by factor $|s(n, d)| = \rho$, then P^* is obtained from P by the same rotation ϕ and expansion ρ , followed by a translation so its center becomes the point $(\sum_{i=0}^{n-1} b_i) c$.

Clearly, if (6) is the zero vector, P^* will be a point polygon (since then $r = 0$), and b must be an (n/d) -dotting vector. Except when n is even and $d = n/2$, the condition for this to happen is that both components of $t(n, d)$ are zero, that is

$$\begin{aligned} t_x(n, d) &= x_0 + x_1 \cos \theta + x_2 \cos 2\theta + \dots + x_{n-1} \cos (n-1)\theta = 0 \\ t_y(n, d) &= x_1 \sin \theta + x_2 \sin 2\theta + \dots + x_{n-1} \sin (n-1)\theta = 0 \end{aligned}$$

where $(x_0, x_1, \dots, x_{n-1})$ are coordinates in the space $\mathbf{S}(n)$. Hence in this case $\mathbf{D}(n/d)$ is defined by two independent linear equations, and its dimension is therefore $n-2$.

In the case where n is even and $d = n/2$, the vanishing of $s(n, d)$ leads to only one equation since the components are proportional. This equation is

$$t(n, \frac{1}{2}n) = x_0 - x_1 + x_2 - x_3 + \dots + x_{n-1} = 0,$$

and so $\mathbf{D}(n, \frac{1}{2}n)$ has dimension $n-1$. \diamond

It is worth noting that if $d_1 \neq d_2$ and $b = c(n, d_1)$ or $s(n, d_1)$, then $t(n, d_2)$ is the zero vector. Also, if $d_1 = d_2 \neq n/2$ and $b = c(n, d_1)$ then $t(n, d_2) = 0$.

Putting all this information together we arrive at the following result, which completely describes the relationship between the spaces $\mathbf{R}(n/d)$, $\mathbf{D}(n/d)$, $\mathbf{C}(n/d)$ and $\mathbf{A}(n/d)$.

Theorem N3.13. In $\mathbf{S}(n)$, the space of all n -dimensional smoothing vectors, let \mathbf{O} be

the vector subspace defined by the equation $\sum_{j=0}^{n-1} x_j = 0$, and \mathbf{I} be the affine subspace

defined by the equation $\sum_{j=0}^{n-1} x_j = 1$. Then for all n and d_1 :

$$(i) \mathbf{A}(n/d_1) = \mathbf{D}(n/d_1) \cap \mathbf{O},$$

$$(ii) \mathbf{C}(n/d_1) = \mathbf{D}(n/d_1) \cap \mathbf{I},$$

$$(iii) \mathbf{R}(n/d_1) = \bigcap \mathbf{D}(n/d)$$

where the intersection is taken over all $d = 1, 2, \dots, n-1$ except for $d = d_1$.

The last assertion follows because every vector belonging to the intersection in (iii) reduces every regular (n/d) -component of an arbitrary n -gon to a point, except for the (n/d_1) -component.

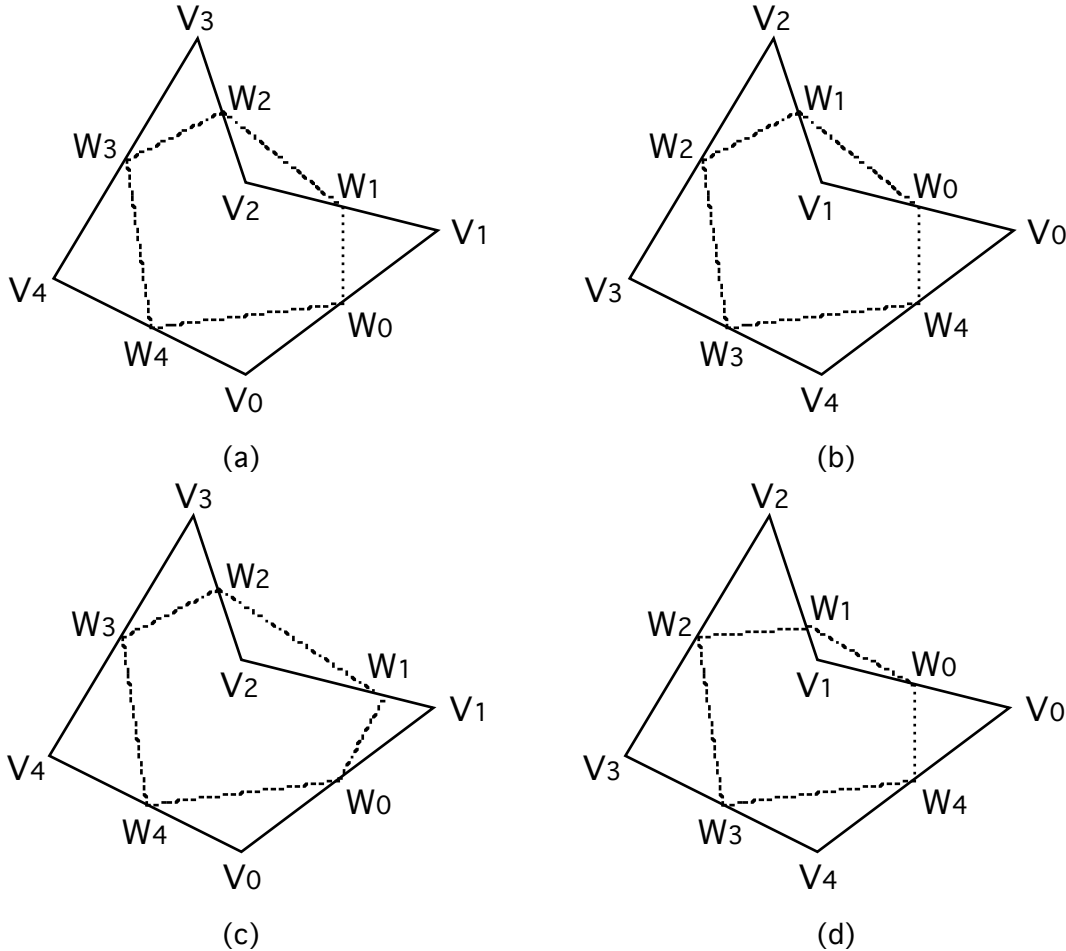

Figure N3.1. The rooted polygon $Q = (W_0, W_1, W_2, W_3, W_4)$ is the image of the rooted polygon $P = (V_0, V_1, V_2, V_3, V_4)$ under a linear transformation. The transformation in parts (a) and (b) is the smoothing transformation $S(b)$ determined by the smoothing vector $b = (1/2, 1/2, 0, 0, 0)$; these terms are explained in the text. The polygons P and Q in part (b) arise from polygons with the same name in part (a) by the transformation ζ which advances the root vertex to the second vertex of the original polygon. Since $S(b)$ is a smoothing operation, its action on the (unrooted) polygons is the same in parts (a) and (b). In contrast, the transformation used in (c) and (d) is not a smoothing transformation, since its matrix differs from that of $S(b)$ by having the first row $(4/3, 1/4, 0, 0, 0)$, making it a noncirculant matrix. The transformation is not determined on the unrooted polygons.

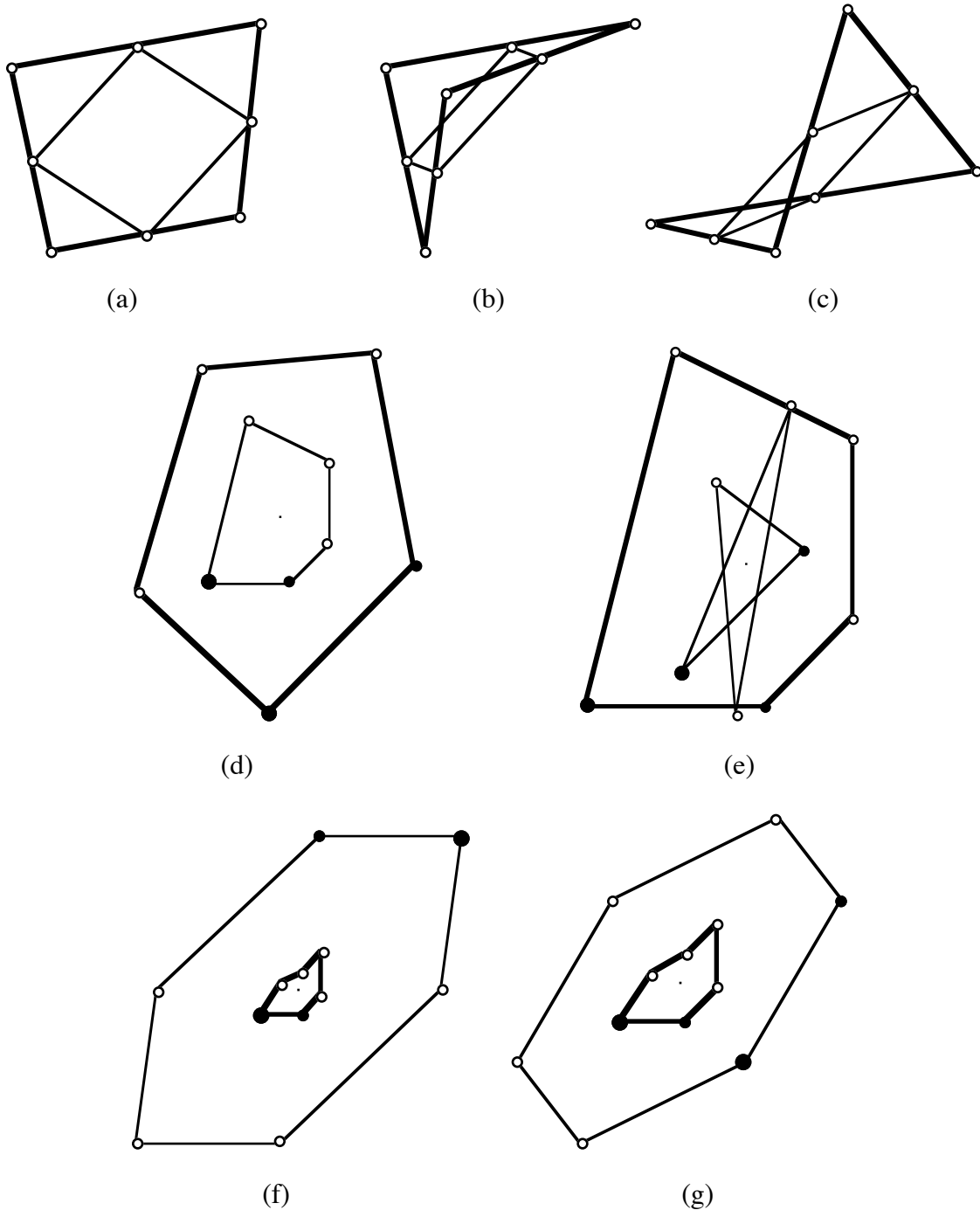

Figure N3.2. Examples of the action of some regularizing vectors. (a), (b), (c) show results of applying the $(4/1)$ -regularizing vector $b = (1/2, 1/2, 0, 0)$. (d) illustrates the $(5/1)$ -regularizing vector $b = (1, 1.61803\dots, 1, 0, 0)$, and (e) the $(5/2)$ -regularizing vector $b = (1, -0.618934\dots, 1, 0, 0)$. (f) and (g) show the action of the $(6/1)$ -regularizing vectors $b = (-1, 0, 2, 3, 2, 0)$ and $b = (1, 2, 2, 1, 0, 0)$. The starting polygons are shown in heavy lines.

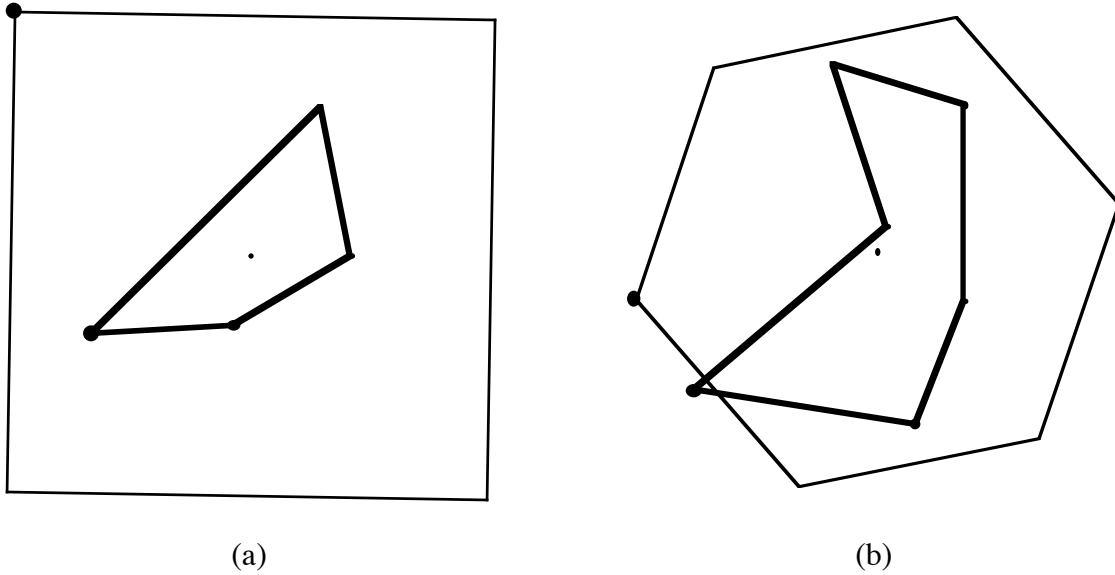

Figure N3.3. Examples of the action of some strictly regularizing vectors. In (a) the strictly (4/1)-regularizing vector is $(1-i, -1-i, -1+i, 1+i)/2$, and in (b) the strictly (6/1)-regularizing vector is $(3-i\sqrt{3}, -2i\sqrt{3}, -3-i\sqrt{3}, -3+i\sqrt{3}, 2i\sqrt{3}, 3+i\sqrt{3})/12$.

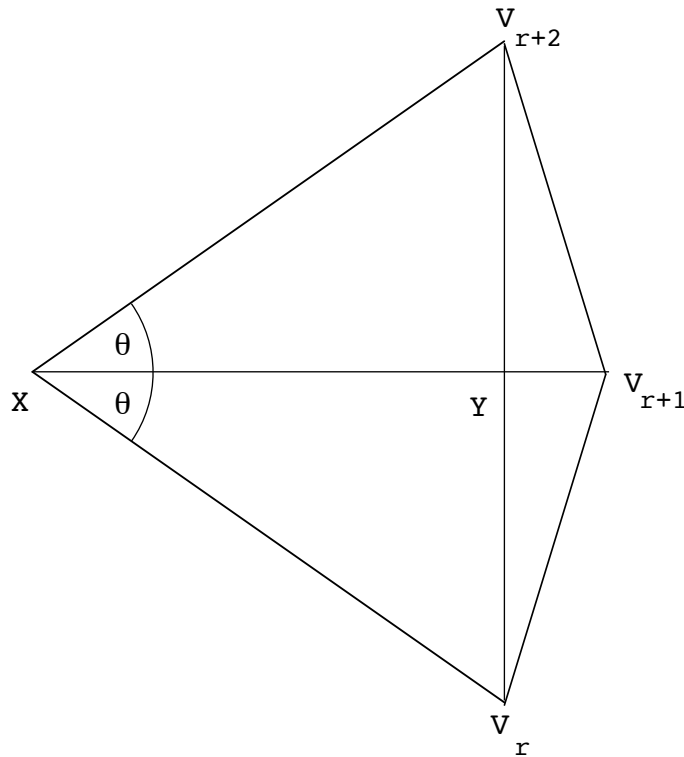
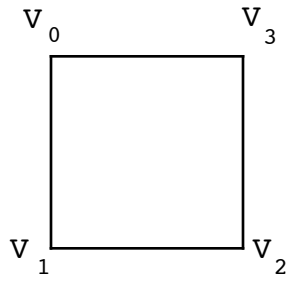
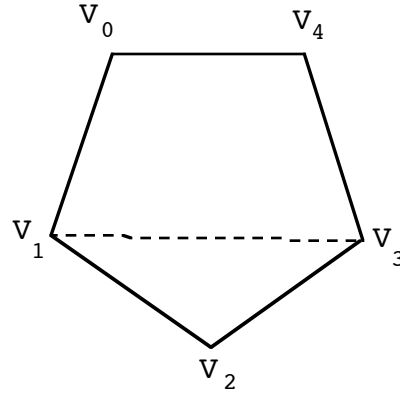

Figure N3.4. V_r, V_{r+1}, V_{r+2} are three consecutive vertices of an (n/d) -gon centered at X , and $\theta = 2\pi d/n$. This diagram is used in establishing equation (2) and thereby constructing an (n/d) -centralizing vector.



$$n = 4, d = 1$$

$$f = (1, 1, -1, -1)$$



$$n = 5, d = 1$$

$$f = (1, t, 0, -t, -1)$$

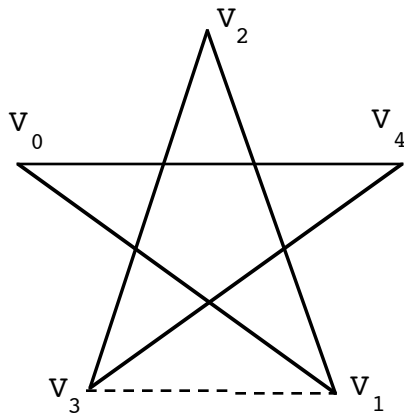

$$n = 5, d = 2$$

$$f = (1, 1-t, 0, t-1, -1)$$

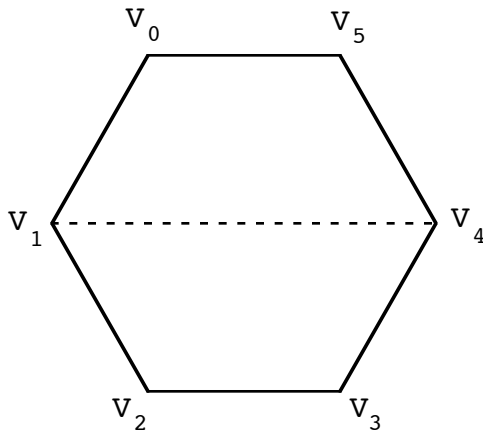

$$n = 6, d = 1$$

$$f = (1, 2, 1, -1, -2, -1)$$

Figure N3.5. Examples illustrating the calculation of the regularizing vectors $f = f(n,d)$ defined in Corollary N3.8.

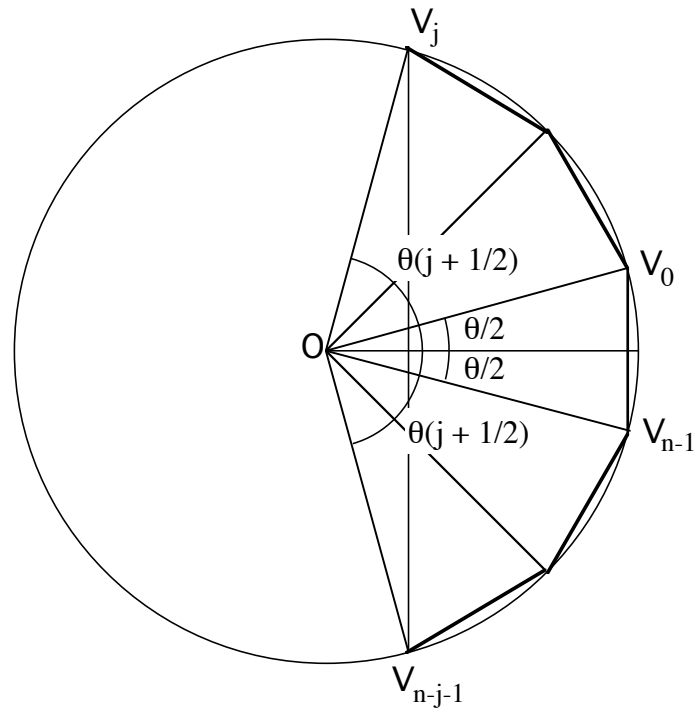

Figure N3.6. Illustration of the arguments in the proof of Corollary N3.8.

N4. Affine-Regular Components.

From Corollary N2.3 and the accompanying comments we know that each rooted n -gon P can be written uniquely as a vertex sum of a point polygon and the $m = \lfloor n/2 \rfloor$ affine-regular rooted n -gons $A_d = \alpha_{n,d}(P)$ called the affine-regular components of P :

$$P = A_0 + \dots + A_m, \quad (1)$$

where $A_d \in \mathcal{A}(n/d)$. In Section N1, vectors representing these components were obtained as the images, under orthogonal projection onto the subspaces $\mathbf{U}(n/d)$, of the vector representing P . We shall now show how the vectors representing the affine-regular components A_d , and thus also the decomposition into affine-regular components, can also be obtained using smoothing vectors.

We begin by considering the regularizing vectors $c(n,d)$ introduced in Section N3 and defined by

$$c(n,d) = \frac{1}{n} (1, \cos \theta, \cos 2\theta, \dots, \cos (n-1)\theta)$$

with $\theta = 2\pi d/n$. In order to reduce the number of parentheses, we shall use the notation $c_{n,d}$ instead of $c(n,d)$.

From Corollary N3.7 we know that $\sum_{d=0}^m \varepsilon_{n,d} c_{n,d} = u$, where $u = (1, 0, 0, \dots, 0)$, with $\varepsilon_{n,d} = 1$ if $d = 0$ or $n/2$ (for even n) and $\varepsilon_{n,d} = 2$ in all other cases. Hence for any n -gon P

$$\sum_{d=0}^m \varepsilon_{n,d} S(c_{n,d})P = S\left(\sum_{d=0}^m \varepsilon_{n,d} c_{n,d}\right)P = S(u)P = \mathbf{I}P = P, \quad (2)$$

where the shadowed summation sign represents a vertex sum of polygons, and $S(b)$ is the smoothing operation with smoothing vector b . Then, recalling that $c_{n,d}$ is an (n/d) -regularizing vector and hence that $\varepsilon_{n,d} S(c_{n,d})P$ is an affine-regular (n/d) -gon, by comparing (1) and (2) it follows from the uniqueness of the decomposition into affine-regular components that $\varepsilon_{n,d} S(c_{n,d})P$ is the affine-regular (n/d) -component A_d of P .

It is worth noting that if $d \neq 0$, the sum of the components of the smoothing vector $c_{n,d}$ is 0. Hence by Theorem N3.1(v) each of the components A_1, A_2, \dots, A_m

is centered at the origin. Since the sum of the components of $c_{n,0}$ is 1, by Theorem N3.1(iv) the component A_0 is a point polygon whose center coincides with that of P .

Finally we observe that, since the representation (1) of P is unique, if P is an affine-regular (n/d) -gon for some $d \neq 0$, then all the components in (1) must be zero polygons except for A_0 and A_d . In other words, in this case, A_d is the translate of P whose center lies at the origin, and A_0 is a point polygon which coincides with the center of P . Thus we have:

Theorem N4.1. If $e \neq d$ and $e \neq 0$, then the (n/e) -regularizing vector $c_{n,e}$ is an (n/d) -annihilating vector; the vector $c_{n,0}$ is an (n/d) -centralizing vector.

* * * * *

If g_d is an (n/d) -centralizing vector, then the smoothing operation $S(g_d)$ applied to P has the effect of annihilating its affine-regular (n/d) -component, and, by Theorem N3.1(vii), mapping every other affine-regular (n/e) -component of P to an affine-regular (n/e) -gon. Hence, given a set $\{g_0, g_1, \dots, g_{m-1}\}$ of centralizing vectors and applying, in any order, all the smoothing operations $S(g_d)$ with $d \neq e$, we obtain an affine-regular (n/e) -gon P^* . However, much more can be said in the special case that $g_d = b_{n,d}$, where

$$b_{n,d} = \frac{1}{2} (1 - \cos \theta)^{-1} (-2 \cos \theta, 1, 0, \dots, 0, 1) \quad \text{for } d = 1, 2, \dots, m,$$

is the vector we have seen in Theorem N3.2 (called there $b^{(1)}$), and $\theta = 2\pi d/n$. The procedure just described yields now polygons homothetic to the affine-regular components of the starting polygon. Specifically, we have:

Theorem N4.2. Let $(d_0, d_1, \dots, d_{m-1})$ be a permutation of $(1, 2, \dots, m)$ and let P be any n -gon. Then $Q = S(b_{n,d_1}) S(b_{n,d_2}) \dots S(b_{n,d_{m-1}}) P$ is an affine-regular (n/d_0) -gon. More precisely, Q has the same center as P and is homothetic to the affine-regular (n/d_0) -component of P . The ratio of homothecy is

$$\lambda = \prod_{j=1}^{m-1} \lambda(n, d_j, d_0),$$

where $\lambda(n, d_j, d_0) = (\cos d_0\phi - \cos d_j\phi)/(1 - \cos d_j\phi)$, with $\phi = 2\pi/n$.

Proof The assertions concerning the affine-regularity of Q and the coincidence of its center with that of P follow from Theorems N4.1 and N3.1(iv), by observing that the sum of the components of each vector $b_{n,d}$ is 1.

The (possibly negative) coefficient of homothety can be calculated quite easily, since we may determine $\lambda(n, d, d_0)$ by considering the case in which P is the standard regular (n/d_0) -gon $R_{n,d}$. From the symmetry of the construction (see Figure N4.1) it follows that $\lambda(n, d, d_0) = |CD|/|CV_0|$, hence

$$\lambda(n, d, d_0) = \left(\cos \frac{2\pi d_0}{n} - \cos \frac{2\pi d}{n} \right) / \left(1 - \cos \frac{2\pi d}{n} \right),$$

as claimed. \diamond

The result of Theorem N4.2 is illustrated in the first two parts of Figure N4.2. It shows, in (a), the decomposition of a pentagon into the vertex sum of its affine-regular components and in (b) the affine-regular polygons obtained by applying to it either $S(b_{n,1})$ or $S(b_{n,2})$. As $m = \lfloor 5/2 \rfloor = 2$, so $m - 1 = 1$, and the ratio of homothety λ reduces to a single factor $\lambda(5, 1, 2) = 5.854101966\dots$ or $\lambda(5, 2, 1) = -0.854101966\dots$. The meaning of part (c) will become clear soon.

* * * * *

The smoothing operations $S(b_{n,d})$ have an unexpected geometric description which is analogous to the generalizations of Napoleon's Theorem for polygons to be discussed later.

Given n and d (with $1 \leq d < n/2$) and three not necessarily distinct and possibly collinear points, there is a unique affine-regular polygon in $\lfloor (n/d) \rfloor$ for which the given points are three successive vertices. Starting from a given n -gon P , and applying this construction to every triplet of consecutive vertices of P we obtain n affine-regular (n/d) -gons. Their centers form a new n -gon which we shall denote by $P^{(d)}$. If n is even, for $d = n/2$ we define $P^{(d)}$ as the n -gon obtained from P by applying the smoothing vector $(\frac{1}{4}, \frac{1}{2}, \frac{1}{4}, 0, 0, \dots, 0)$ - in other words we take the midpoints of the edges of P as the vertices of a polygon P^* , and then $P^{(n/2)}$ is the polygon whose vertices are the midpoints of the edges of P^* . The analogue of Theorem N4.2, illustrated for $n = 4$ and $n = 6$ in Figure N4.3, is:

Theorem N4.3. Let $(d_0, d_1, \dots, d_{m-1})$ be a permutation of $(1, 2, \dots, m)$ and let P be any n -gon. Then the n -gon $Q^* = P^{(d_1)}(d_2)\dots(d_{m-1})$ is an affine-regular (n/d_0) -gon. Moreover, Q^* coincides with the polygon Q in Theorem N4.2.

Proof In order to show that $Q^* = Q$, it is sufficient to establish that $P^{(d)} = S(b_{n,d})P$. To find the center C of an affine-regular (n/d) -gon determined by noncollinear points V_{-1}, V_0, V_1 taken as three consecutive vertices, we may without loss of generality

assume that the resulting polygon is the standard regular polygon $R_{n,d}$. Then (see Figure N4.4) we clearly have

$$C = (2 - 2 \cos \theta)^{-1} (V_{-1} - 2 V_0 \cos \theta + V_1), \tag{3}$$

where $\theta = 2\pi d/n$. Thus $P^{(d)}$ is obtained from P by using the smoothing operation determined by the smoothing vector $b = (2 - 2 \cos \theta)^{-1} (-2 \cos \theta, 1, 0, \dots, 0, 1)$, which coincides with $b_{n,d}$. The case of collinear starting triplet of points may be disposed of by approximation and continuity, or by direct calculations. \diamond

* * * * *

As we shall see later, it is of some interest to consider polygons in families determined by the requirement that certain affine-regular components are either absent, or else guaranteed to be present, in the decomposition of the polygon into the vertex sum of affine-regular (n/d) -components given by Corollary N2.3. In order to be able to concisely deal with such situations, we introduce the following notation. Let $D = \{d_1, d_2, \dots, d_k\}$ be a set of integers such that $1 \leq d_1 < d_2 < \dots < d_k \leq n/2$. We shall denote by $\mathbf{A}(n, \subset D)$ the set of those n -gons for which the affine-regular (n/d) -component is nontrivial only if $d \in D$. We shall use the symbols $\mathbf{A}(n, = D)$, $\mathbf{A}(n, \supset D)$, $\mathbf{A}(n, \parallel D)$, in a similar way, to indicate the families of those n -gons P for which the set

$$\{d \mid \text{the affine-regular } (n/d)\text{-component of } P \text{ is nontrivial}\}$$

equals D , contains D , or is disjoint from D , respectively.

In a few cases with small n , reasonably simple geometric conditions characterize the polygons belonging to some of these sets. The examples given below follow directly from the definitions.

Examples N4.1. (1) If $n = 4$ or 5 there are only $m = [n/2] = 2$ affine-regular components, so the absence of one implies that the polygon must be a translate of the other. For example, if $n = 5$, then $P \in \mathbf{A}(5, \parallel \{1\})$ means that the affine-regular $(5/1)$ -component of P is absent; this happens if and only if $P \in \mathbf{A}(5, = \{2\})$ is an affine-regular $(5/2)$ -gon (pentagram).

(2) A hexagon $P = [V_0, \dots, V_5] \in \mathbf{A}(6, \parallel \{1\})$ if and only if one of the following equivalent conditions holds (see Figure N4.5(a)):

(a) For each $i = 0, \dots, 5$, $v_i - v_{i+3} = v_{i+4} - v_{i+1}$, that is, the principal diagonals of P are equal in length and parallel.

(b) For each $i = 0, \dots, 5$, the centers of opposite edges $[V_i, V_{i+1}]$ and $[V_{i+3}, V_{i+4}]$ coincide. In other words, the midpoints of the edges of P are the vertices of a (6/2)-gon.

(c) The centroids of each of the six triples of consecutive vertices of P are the vertices of an affine-regular (6/3)-gon.

(3) A hexagon $P = [V_0, \dots, V_5] \in \mathbf{A}(6, \parallel \{2\})$ if and only if the midpoints of the edges of P are the vertices of an affine-regular (6/1)-gon (see Figure N4.5(b)).

(4) A hexagon $P = [V_0, \dots, V_5] \in \mathbf{A}(6, \parallel \{2\})$ if and only if the centroids of triples of consecutive vertices of P are the vertices of an affine-regular (6/1)-gon (see Figure N4.5(c)).

* * * * *

We conclude this section by establishing the result mentioned in Section N2.

Theorem N4.4. If P is a rooted n -gon centered at the origin, and

$$P = A_1 + \dots + A_m, \tag{4}$$

is its representation as a vertex sum of $m = \lfloor n/2 \rfloor$ affine-regular (n/d) -gons then

$$\alpha(P) = \alpha(A_1) + \dots + \alpha(A_m) \tag{5}$$

where α denotes the signed areas of the polygons.

Notice that although area is not an affine invariant, relation (5) is a valid statement in affine geometry. For if it holds in any Euclidean realization of the polygons, then applying an affine transformation will multiply all the areas by the same factor. In the following proof it is therefore sufficient to work in the Euclidean plane.

Proof We determine the affine-regular components A_d using the regularizing vectors $c(n, d)$ of Corollary N3.6. Consider first A_d where $0 < d < n/2$. Then the first two vertices W_0 and W_1 of $A_d = [W_0, W_1, \dots, W_{n-1}]$ have position vectors given by

$$w_0 = \frac{2}{n} (v_0 + v_1 \cos d\phi + v_2 \cos 2d\phi + \dots + v_{n-1} \cos (n-1)d\phi)$$

$$w_1 = \frac{2}{n} (v_0 \cos (n-1)d\phi + v_1 + v_2 \cos d\phi + \dots + v_{n-1} \cos (n-2)d\phi)$$

where $P = [V_0, \dots, V_{n-1}]$ and $\phi = 2\pi/n$. Let the coordinates of V_i be $(v_{i,0}, v_{i,1})$ and those of W_j be $(w_{j,0}, w_{j,1})$. Then the area of the triangle $[O, W_0, W_1]$ is

$$\frac{1}{2} \det \begin{bmatrix} w_{00} & w_{01} \\ w_{10} & w_{11} \end{bmatrix} \quad (6)$$

where

$$w_{0,0} = v_{0,0} + v_{1,0} \cos d\phi + v_{2,0} \cos 2d\phi + \dots + v_{n-1,0} \cos (n-1)d\phi,$$

$$w_{0,1} = v_{0,1} + v_{1,1} \cos d\phi + v_{2,1} \cos 2d\phi + \dots + v_{n-1,1} \cos (n-1)d\phi,$$

$$w_{1,0} = v_{0,0} \cos (n-1)d\phi + v_{1,0} + v_{2,0} \cos d\phi + \dots + v_{n-1,0} \cos (n-2)d\phi$$

$$w_{1,1} = v_{0,1} \cos (n-1)d\phi + v_{1,1} + v_{2,1} \cos d\phi + \dots + v_{n-1,1} \cos (n-2)d\phi$$

Upon substituting, we see that the determinant (6) may be written as the sum of n^2 terms, thus

$$\frac{2}{n^2} \sum v_{r,0} v_{s,1} \det \begin{bmatrix} \cos rd\phi & \cos sd\phi \\ \cos(r-1)d\phi & \cos(s-1)d\phi \end{bmatrix} \quad (7)$$

where the summation here, and in all later sums where no bounds are indicated, is over all r and s in the range 0 to $n-1$. The coefficient of $v_{r,0} v_{s,1}$ in (7) is

$$\begin{aligned} & \cos rd\phi \cos(s-1)d\phi - \cos(r-1)d\phi \cos sd\phi \\ &= \frac{1}{2} (\cos(r+s-1)d\phi + \cos(r-s+1)d\phi - \cos(r+s-1)d\phi - \cos(r-s-1)d\phi) \\ &= \frac{1}{2} (\cos(r-s+1)d\phi - \cos(r-s-1)d\phi) \end{aligned}$$

and therefore (7) takes the value

$$\frac{1}{n^2} \sum v_{r,0} v_{s,1} (\cos(r-s+1)d\phi - \cos(r-s-1)d\phi). \quad (8)$$

Since only the difference $(r-s)$ occurs in the coefficients, it follows that all the triangles $[O, W_0, W_1], [O, W_1, W_2], \dots, [O, W_{n-1}, W_0]$ have equal areas. This is obvious geometrically since $A_d = [W_0, W_1, \dots, W_{n-1}]$ is an affine-regular (n/d) -gon centered at O . Hence the total area of A_d can be found by multiplying (8) by n , that is,

$$\begin{aligned}
\alpha(A_d) &= \frac{1}{n} \sum v_{r,0} v_{s,1} (\cos(r-s+1)d\phi - \cos(r-s-1)d\phi) \\
&= \frac{1}{2n} \sum v_{r,0} v_{s,1} (\cos(r-s+1)d\phi + \cos(r-s+1)(n-d)\phi \\
&\quad - \cos(r-s-1)d\phi - \cos(r-s-1)(n-d)\phi). \tag{9}
\end{aligned}$$

A similar calculation for $d = 0$ yields the value 0 which we may write in the form

$$\alpha(A_d) = \sum v_{r,0} v_{s,1} (\cos(r-s+1).0\phi - \cos(r-s-1).0\phi) \tag{10}$$

and if n is even, so $n = 2m$, the area of the (n/m) -component also turns out to be 0 which we can write in the form

$$\alpha(A_d) = \frac{1}{2n} \sum v_{r,0} v_{s,1} (\cos(r-s+1)m\phi - \cos(r-s-1)m\phi). \tag{11}$$

From (9), (10) and (11) we obtain

$$\alpha(A_1) + \dots + \alpha(A_m) = \frac{1}{2n} \sum v_{r,0} v_{s,1} \left(\sum_{d=0}^{n-1} \cos(r-s+1)d\phi - \sum_{d=0}^{n-1} \cos(r-s-1)d\phi \right).$$

All the terms in the sum vanish except when the coefficient of ϕ is 0, and this occurs if $r - s = \pm 1$. In this case the sum of the coefficients is n . Hence

$$\begin{aligned}
\alpha(A_1) + \dots + \alpha(A_m) &= \left[\begin{array}{cc} v_{r,0} & v_{r,1} \\ v_{r+1,0} & v_{r+1,1} \end{array} \right] - \sum_{r=0}^{n-1} v_{r+1,0} v_{r,1} \\
&= \sum_{r=0}^{n-1} \det \begin{bmatrix} v_{r,0} & v_{r,1} \\ v_{r+1,0} & v_{r+1,1} \end{bmatrix} = \sum_{r=0}^{n-1} a([O, V_r, V_{r+1}]) = \alpha(P).
\end{aligned}$$

Therefore the area of P is equal to the sum of the areas of its affine components. \diamond

There is a corresponding result for the regular components of an n -gon:

Corollary N4.5. If P is an n -gon centered at the origin, and

$$P = R_1 + R_2 + \dots + R_{n-1}$$

is the representation of P in terms of its regular components, then

$$\alpha(P) = \alpha(R_1) + \alpha(R_2) + \dots + \alpha(R_{n-1}) \tag{12}$$

where α represents the signed areas of the polygons.

Proof In all cases, except when $n = 2d$, we have (see Corollary N2.2)

$$Q_d = R_d + R_{n-d}$$

where Q_d is an affine-regular (n/d) -gon, and R_d, R_{n-d} are regular (n/d) - and $(n/(n-d))$ -gons. Referring to the proof of Corollary N2.2 and using the same notation, we see that

$$\alpha(Q_d) = (b/a) \alpha(R),$$

$$\alpha(R_d) = [(a+b)/2a]^2 \alpha(R)$$

$$\alpha(R_{n-d}) = [(a-b)/2a]^2 \alpha(R) = -[(a-b)/2a]^2 \alpha(R).$$

Hence $\alpha(Q_d) = \alpha(R_d) + \alpha(R_{n-d})$. Thus for $d = 1, \dots, [(n-1)/2]$,

$$\alpha(A_d) = \alpha(R_d) + \alpha(R_{n-d}).$$

Substituting these values in (5), and noting that $\alpha(R_{n/2}) = 0$, we obtain (12). \diamond

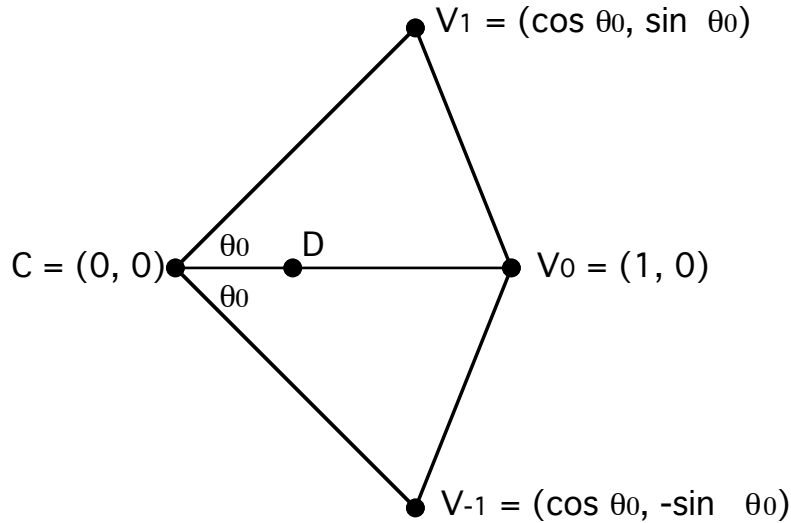

Figure N4.1. An illustration of the calculation of the coefficient of homothety $\lambda(n,d,d_0)$ using three adjacent vertices of the regular (n/d_0) -gon; here $\theta_0 = 2\pi d_0/n$. The point $D = (V_{-1} - 2 \cos \theta V_0 + V_1)/(2 - 2 \cos \theta)$, with $\theta_0 = 2\pi d/n$, is the vertex of the affine-regular (n/d_0) -gon Q that corresponds under $S(b_{n,d})$ to the vertex V_0 of the standard regular (n/d_0) -gon $R_{n,d}$; hence $\lambda(n,d,d_0) = |C,V_0|/|C,D|$, as used in the proof.

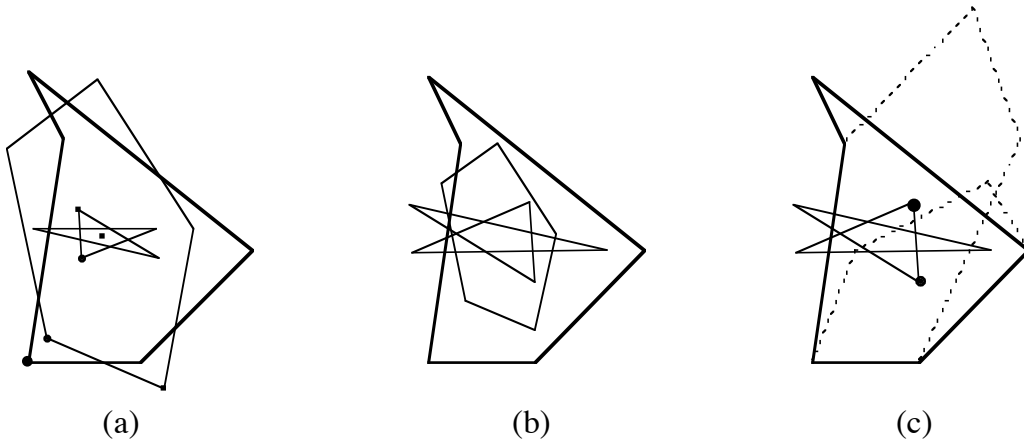

Figure N4.2. Comparison, as explained in the text, of (a) the affine-regular components of a pentagon, to (b) the affine-regular polygons, homothetic to these components, which result by applying the smoothing operations determined by the vectors $b_{n,d}$. The alternative interpretation of the latter, explained in Theorem N4.3, is indicated by the dotted lines in (c). In order to avoid clutter, only two of the affine-regular $(5/1)$ -gons are shown in (c), and their centers — which are vertices of the resulting affinely regular $(5/2)$ -gon — are indicated by the solid dots.

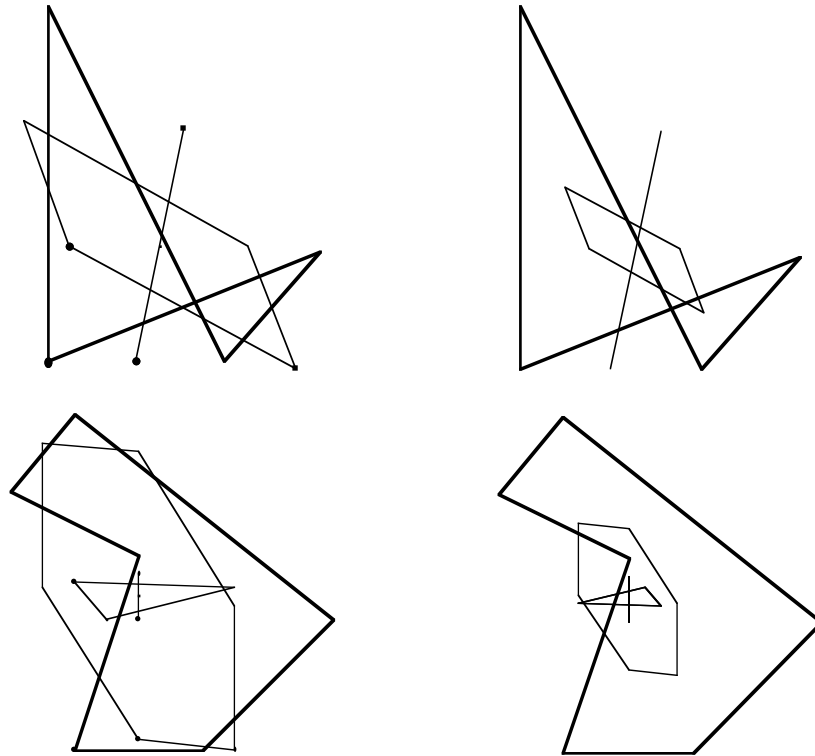

Figure N4.3. Illustrations of the statement of Theorem N4.3 for n -gons with $n = 4$ and $n = 6$ and all possible choices of d_0 are shown on the right. On the left we show, for comparison, the affine-regular components of the same polygons .

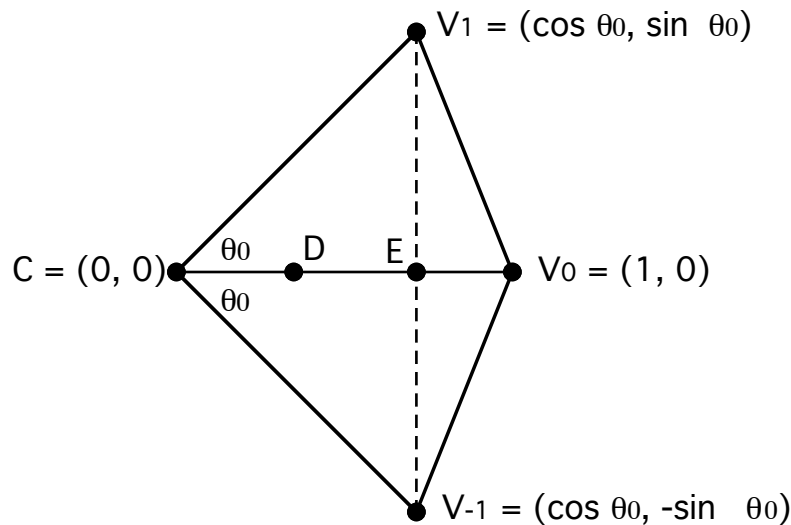

Figure N4.4 The calculation of the coefficients needed to show relation (3) can be accomplished easily using the point $E = (\cos \theta_0, 0)$; here $\theta_0 = 2\pi d_0/n$ is the central angle of the standard regular (n/d_0) -gon $R_{n,d}$. The center of the affine-regular (n/d) -gon is at D , and this is the vertex of $P^{(d)}$ resulting from V_0 . The ratio $CV_0/EV_0 = 1/(1 - \cos \theta_0)$, and similarly $DV_0/EV_0 = 1/(1 - \cos \theta)$, with $\theta = 2\pi d/n$. Then the desired ratio CD/CV_0 has the same value as $\lambda(n,d,d_0)$ from Theorem N4.2.

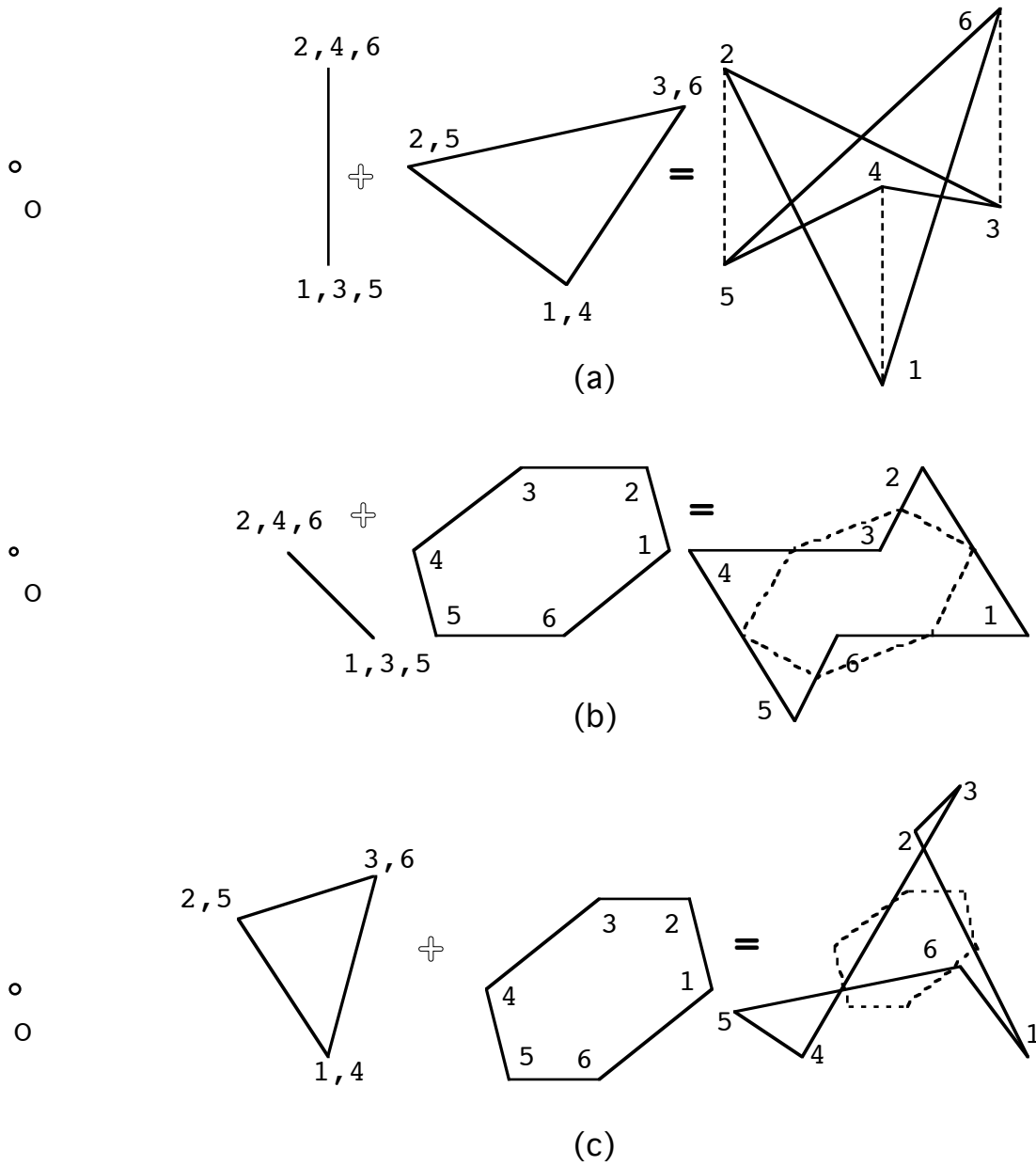

Figure N4.5. Examples of hexagons for which one affine-regular component is missing. The missing component is (6/1) in (a), (6/2) in (b), and (6/3) in (c).

N5. The general Napoleon's Theorem.

In Sections N3 and N4 we were concerned with smoothing operations $S(b)$ determined by smoothing vectors $b = (b_0, b_1, \dots, b_{n-1})$; the components b_j of b , which acted as multipliers of the vectors v_j that represented the vertices of polygons under consideration, were taken as *real* numbers. If their sum satisfies $\sum_{j=0}^{n-1} b_j = 1$, the operation $S(b)$ is independent of the choice of the origin of the coordinate system of \mathbf{E}^2 . One can generalize these ideas by allowing "smoothing vectors" $b = (b_0, b_1, \dots, b_{n-1})$ in which each component b_j is a linear transformation, conveniently represented by a 2×2 matrix. In order to be independent of the coordinate system the components b_j have to add up to the 2×2 identity matrix \mathbf{I}_2 .

For example (see Figure N5.1(a) the smoothing operation $S(b)$ which to each vertex V_j assigns a vertex W_j by the requirement that $w_j - v_j$ is obtained by clockwise rotation through 90° of the vector $(v_{j+1} - v_{j-1})/2$, can be described by

$$b = \left(\left[\begin{array}{cc} 1 & 0 \\ 0 & 1 \end{array} \right], \left[\begin{array}{cc} 0 & 1/2 \\ -1/2 & 0 \end{array} \right], 0, 0, \dots, 0, \left[\begin{array}{cc} 0 & -1/2 \\ 1/2 & 0 \end{array} \right] \right).$$

In particular, if $n = 4$, then the image $Q = S(b)P$ of any quadrangle P is a quadrangle with perpendicular and equally long diagonals, see Figure N5.1(b).

As we shall see later, the ideas of the preceding sections, as well as the one just discussed, can be adapted to polygons in higher-dimensional spaces. However, for our present interests — polygons in the plane — it is both technically and conceptually advantageous to take a different point of view, which we have been mentioning from time to time. So far, each point V has been represented by a vector v , and the case of the plane, we wrote $v = (v_0, v_1)$. From now on, without fear of confusion, we shall use the same notation v for the complex number $v_0 + iv_1$. It turns out that this approach simplifies both the notation and the calculations.

In the previous sections we have been chiefly concerned with the affine properties of polygons where *real* vectors and *real* smoothing operations are appropriate. In this section we shall concentrate on Euclidean properties, and here representation of points in the plane by *complex* numbers, and *complex* smoothing operations are more useful. The reason for this is that in Euclidean geometry, angles and rotations play an important role — in contrast to affine geometry in which angles are not defined. Multiplication by a

complex number $re^{i\phi}$ corresponds to stretching in ratio r and rotation through angle ϕ . Most assertions made about real smoothing vectors continue to hold in the complex case; for example, such operations commute.

It would be possible to derive all the results of this section without the use of complex numbers, continuing to use real vectors as before. Then multiplication by a

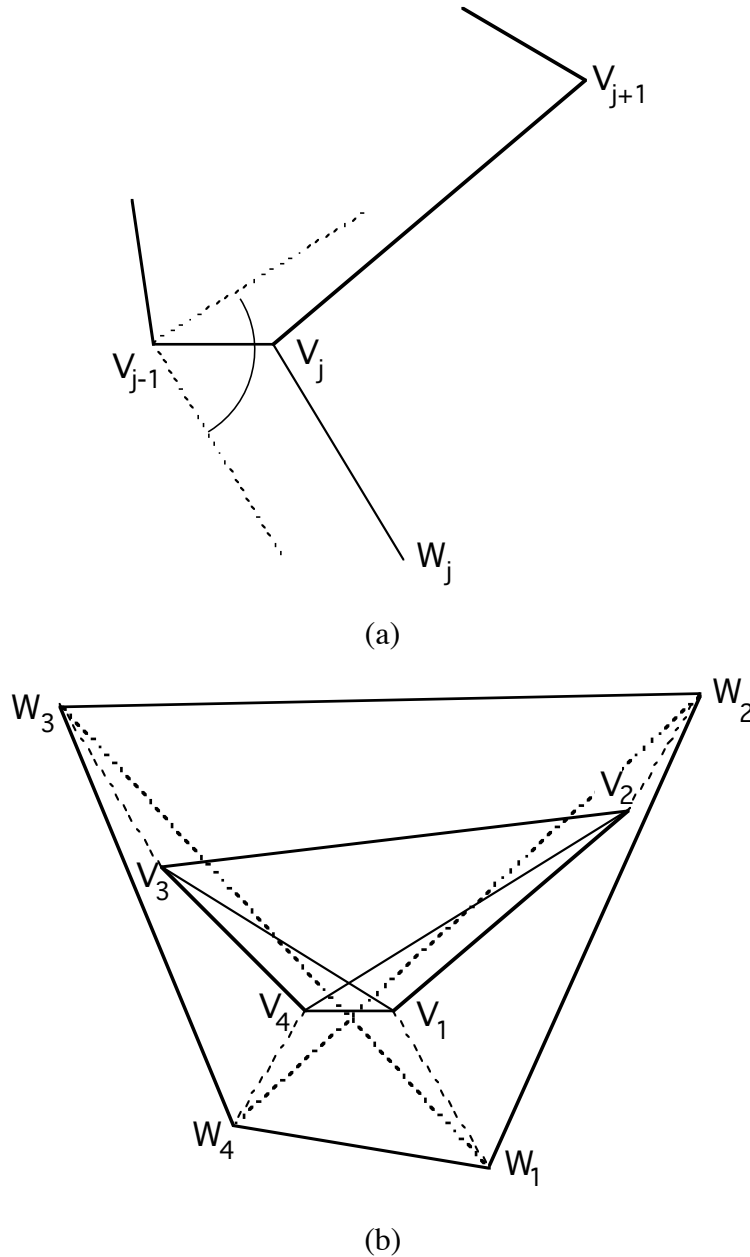

Figure N5.1. (a) A smoothing operation defined by a linear operation described in the text. (b) When applied to an arbitrary quadrangle, this linear operation produces a quadrangle in which the diagonals are perpendicular and have the same length.

complex number would correspond to multiplication by a suitable 2×2 matrix. On the other hand, in contrast to the situation concerning polygons in higher-dimensional spaces, the matrix approach outlined above can be adapted very easily to the use of complex numbers. In the example given above, instead of the matrix $\begin{bmatrix} 0 & 1/2 \\ -1/2 & 0 \end{bmatrix}$ we would use the complex number $-i/2$, and the smoothing vector $(1, -i/2, 0, \dots, 0, i/2)$.

The merits of the approach using complex numbers is well illustrated by our first theorem, which may be regarded as the Euclidean counterpart of Theorem N2.2.

Theorem N5.1. The polygon $P = [V_0, \dots, V_{n-1}] \in \mathcal{A}(n)$ is a regular (n/d) -gon if and only if either P is a point polygon or

$$(h - (h+1)Z + Z^2)v_j = \mathbf{o} \quad \text{for all } j = 0, 1, \dots, n-1,$$

where $h = e^{i\theta} = \cos \theta + i \sin \theta$, with $\theta = \frac{2\pi d}{n}$, and \mathbf{o} is the zero vector.

Proof. It is clear that if P is not a point polygon, then it is a regular (n/d) -gon if and only if each edge $[V_j, V_{j+1}]$ is the same length as its successor $[V_{j+1}, V_{j+2}]$, and the latter is obtained from $[V_j, V_{j+1}]$ by rotation through the angle $2\pi d/n$. In terms of complex numbers this condition is

$$h(v_{j+1} - v_j) = (v_{j+2} - v_{j+1})$$

where h is defined as in the theorem. Thus

$$hv_j - (h + 1)v_{j+1} + v_{j+2} = \mathbf{o},$$

which, since this holds for $j = 0, 1, \dots, n-1$, is equivalent to the condition stated in the theorem. \diamond

Now let P be any n -gon. A new n -gon $Q = \mathcal{T}_{n,d}(P)$, where $0 < d < n$, is obtained from P by the following **(n,d) -similarity transformation** $\mathcal{T}_{n,d}$: First, for each edge E of P a polygon R_E similar to the regular (n/d) -gon $R_{n,d}$ is constructed in such a way that an edge of R_E coincides with E , including the direction. Then Q is obtained by taking the centers of the n polygons R_E as vertices, and taking them in the order inherited from the order of the edges of P . Additionally, we define $\mathcal{T}_{n,0}(P) = P$ for all n -gons P . Clearly, $\mathcal{T}_{n,d}(P)$ is a point polygon if $P \in \mathcal{A}(n/d)$ is (n/d) -regular.

Now the original Napoleon's theorem (see Figure 1.2) can be stated as follows:

For any triangle T , the triangle $\mathcal{B}_{3,1}(T)$ is in $\mathcal{A}(3/2)$, and $\mathcal{B}_{3,2}(T)$ is in $\mathcal{A}(3/1)$. Since $\mathcal{T}_{n,0}$ leaves every polygon unchanged, a more compact statement is: If $\{g,j,k\}$ is a permutation of $\{0,1,2\}$, then $\mathcal{B}_{3,g}\mathcal{B}_{3,j}(T) \in \mathcal{A}(3/k)$ for every triangle T .

Rather than prove Napoleon's Theorem in its original form, it is just as easy to establish it in the following much more general version:

Theorem N5.2. If $(d_0, d_1, d_2, \dots, d_{n-1})$ is any permutation of $(0,1,2, \dots, n-1)$, then

$$\mathcal{T}_{n,d_1}\mathcal{T}_{n,d_2}\mathcal{T}_{n,d_3}\cdots\mathcal{T}_{n,d_{n-1}}(P) \in \mathcal{A}(n/d_0) \quad (2)$$

for every n -gon P .

In other words, if all but one of the n different (n,d) -similarity transformations have been applied to an arbitrary n -gon, the result is a regular polygon of the type that was not used. Naturally, since $\mathcal{T}_{n,0}$ leaves every n -gon unchanged, so including it among the similarity transformations in (1) or excluding it makes no difference in the outcome. The resulting regular polygons are sometimes called the **symmetric components** of P . These are **not** to be confused with the (n/d) -regular components of P , whose vertex sum equals the given polygon P .

An illustration of Theorem N5.2 is given in Figure N5.2, which shows the six essentially different constructions in case $n = 4$; the transformation $\mathcal{T}_{n,0}$ has been ignored.

An alternative, but equivalent, formulation of Theorem N5.2 is that, with (d_0, \dots, d_{n-1}) as above,

$$\mathcal{T}_{n,d_0}\mathcal{T}_{n,d_1}\mathcal{T}_{n,d_2}\mathcal{T}_{n,d_3}\cdots\mathcal{T}_{n,d_{n-1}}(P) = O \quad (2)$$

where P is any polygon and O represents a point polygon.

Proof of Theorem N5.2 We first observe that each (n,d) -similarity transformation $\mathcal{T}_{n,d}$ is, in fact, a smoothing operation. To see this, we remark that if X_j is the center of the n -gon R_E on the side $E = [V_j, V_{j+1}]$ used in the construction (see Figure N5.3), then, by elementary geometry, $[X_j, V_j]$ is obtained by rotating $[V_{j+1}, V_j]$ through angle $\phi = \pi(n - 2d)/2n$ (that is, half the angle at a vertex of a regular (n/d) -gon) and multiplying by $(2 \cos \phi)^{-1}$. Thus, in terms of complex numbers

$$(x_j - v_j) = k(v_{j+1} - v_j)$$

where $k = e^{i\phi}/2 \cos \phi$, with ϕ as above. Hence

$$x_j = v_j(1 - k) + kv_{j+1}$$

for each $j = 0, 1, \dots, n - 1$, which is the smoothing operation $S(b)$ where $b = ((1 - k), k, 0, 0, \dots, 0)$. Further, it is clear geometrically, and can be verified algebraically using the above expression for the smoothing vector, that for each value of d , and each regular (n/d) -gon $R(n/d)$, the resulting polygon $\mathcal{T}_{n,d} R(n/d)$ is a point polygon. In other words, in the terminology of the previous section, we can say that $\mathcal{T}_{n,d}$ **annihilates** every regular (n/d) -gon.

Now let P be any rooted n -gon. Then P can be expressed uniquely in the form

$$P = R(n/0) + R(n/1) + R(n/2) + \dots + R(n/n-1), \quad (3)$$

where $R(n/d)$ is a rooted (n/d) -gon. Since these polygons $R(n/d)$ can be found by applying smoothing operations to P , and the smoothing operations $\mathcal{T}_{n,d}$ commute with these, it follows that $\mathcal{T}_{n,d}(P)$ is determined when we know how $\mathcal{T}_{n,d}$ acts on each component of P in (3). However, we know that $\mathcal{T}_{n,d}$ annihilates the regular (n/d) -component of P , so if we apply all the operations $\mathcal{T}_{n,1}, \mathcal{T}_{n,2}, \dots, \mathcal{T}_{n,n-1}$, they annihilate all the components, leaving us with a point polygon, thus proving (2). Alternatively, if one $\mathcal{T}_{n,d}$ is omitted, the result is a polygon in $\mathcal{A}(n/d)$ that corresponds to the omitted d , and (1) is immediate. \diamond

The construction in Theorem N5.2 is quite analogous to the results of Theorems N4.2 and N4.3. Specifically, for each n -gon P and each d_0 we obtain from Theorem N5.2 a uniquely determined regular (n/d_0) -gon. On the other hand, the regular (n/d_0) -component of P is also a regular (n/d_0) -gon associated in a unique way with P . A natural question is what is the relationship between these two regular (n/d_0) -gons.

Theorem N5.3. If $(d_0, d_1, d_2, \dots, d_{n-2})$ is any permutation of $(1, 2, \dots, n-1)$, then the regular (n/d_0) -gon $P^* = \mathcal{T}_{n,d_1} \mathcal{T}_{n,d_2} \mathcal{T}_{n,d_3} \dots \mathcal{T}_{n,d_{n-1}} 2P$ is similar to the regular (n/d_0) -component $R(n,d_0)$ of P . The relation is $P^* = -\mu e^{-2i\phi} R(n,d_0)$, where

$$\mu = \prod_{j=1}^{n-2} \mu(n, d_j, d_0),$$

with $\mu(n, d_j, d_0) = \cos \phi - \sin \phi \cot \theta$, $\phi = \frac{\pi d_0}{n}$, $\theta = \frac{\pi d_j}{n}$.

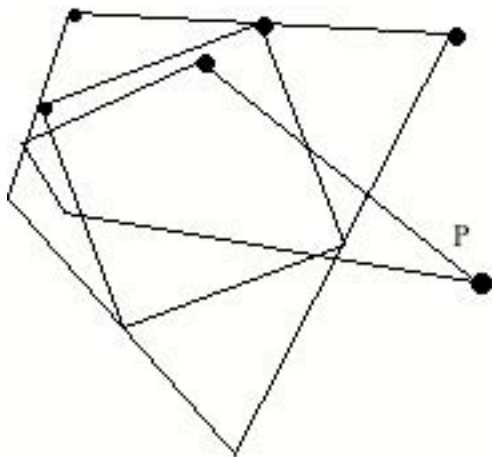

$\mathcal{F}_{4.1} \mathcal{F}_{4.1}(P)$

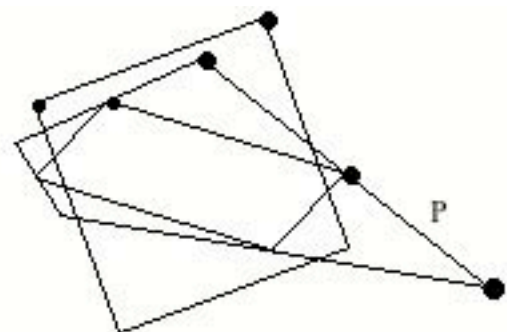

$\mathcal{F}_{4.1} \mathcal{F}_{4.1}(P)$

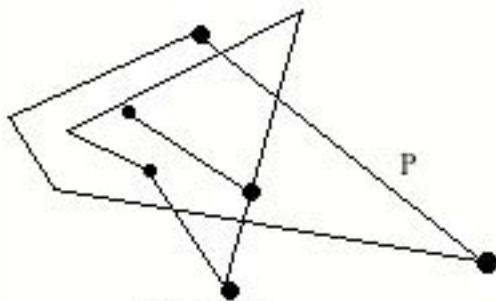

$\mathcal{F}_{4.1} \mathcal{F}_{4.1}(P)$

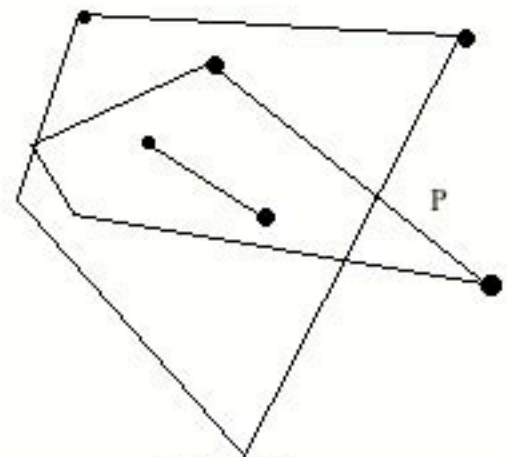

$\mathcal{F}_{4.1} \mathcal{F}_{4.1}(P)$

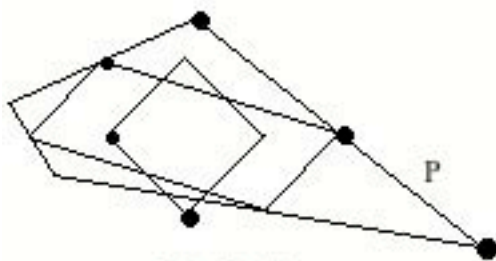

$\mathcal{F}_{4.1} \mathcal{F}_{4.1}(P)$

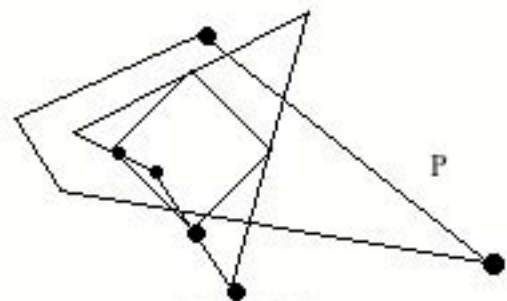

$\mathcal{F}_{4.2} \mathcal{F}_{4.1}(P)$

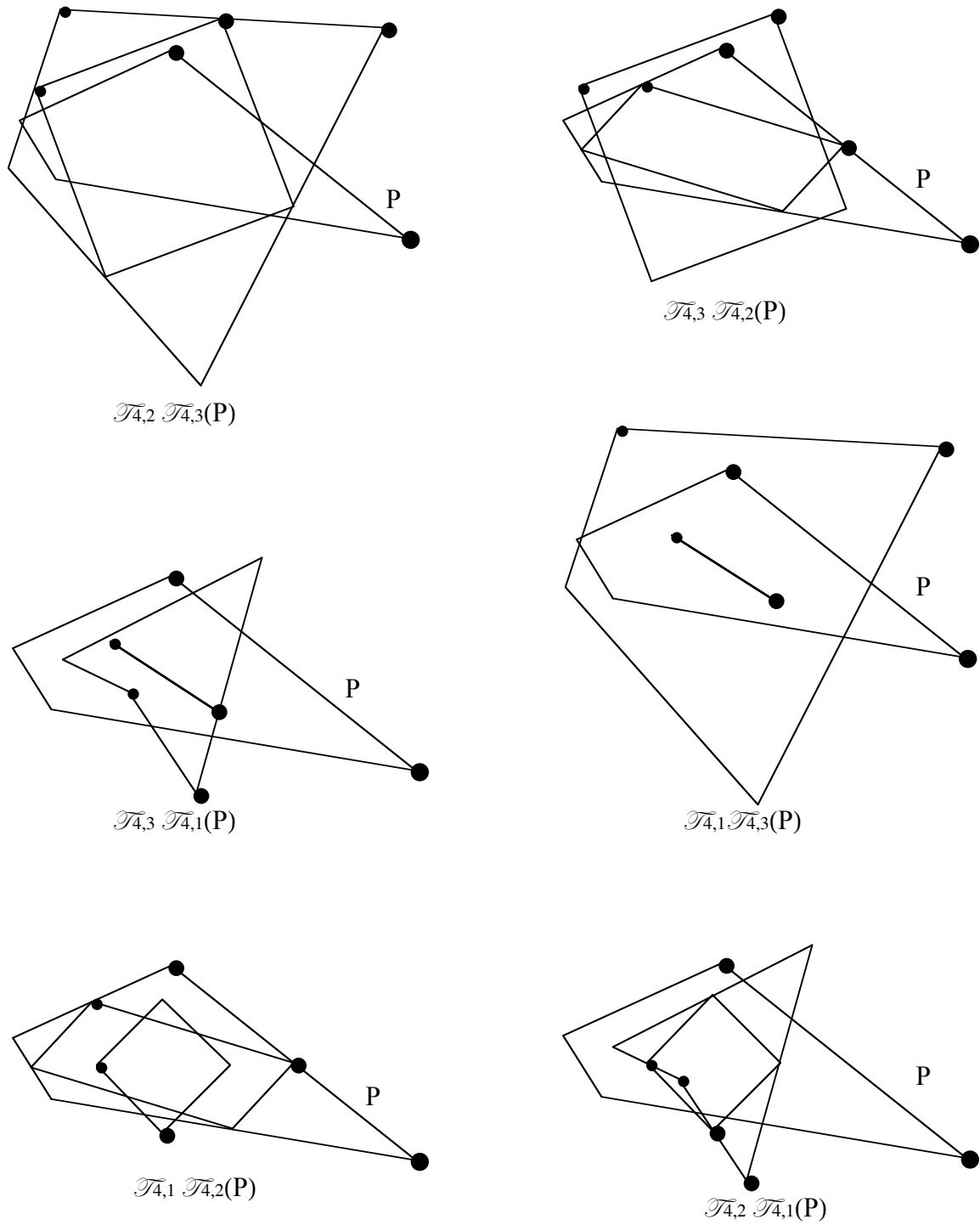

Figure N5.2. Six essentially different instances of Napoleon's theorem, applied to a quadrangle P . To avoid clutter, the regular polygons $R(4,1)$ and $R(4,3)$ used in the construction are not shown. The orientation of each quadrangle is indicated by the transition from the large dot to the mid-sized dot. The three constructions in each column give the three symmetric components of the quadrangle P .

Proof. It is enough to consider the case in which P is centered at the origin Y , and $P = R\{n,d_0\}$; this last, because all other regular components of P are annihilated. Then (compare Figure N5.4) it is clear that the similarity \mathcal{T}_{n,d_j} consists of a rotation through ϕ about the origin Y , and a homothety in ratio $|Y, X_k|/|Y, V_k|$. As is easily calculated,

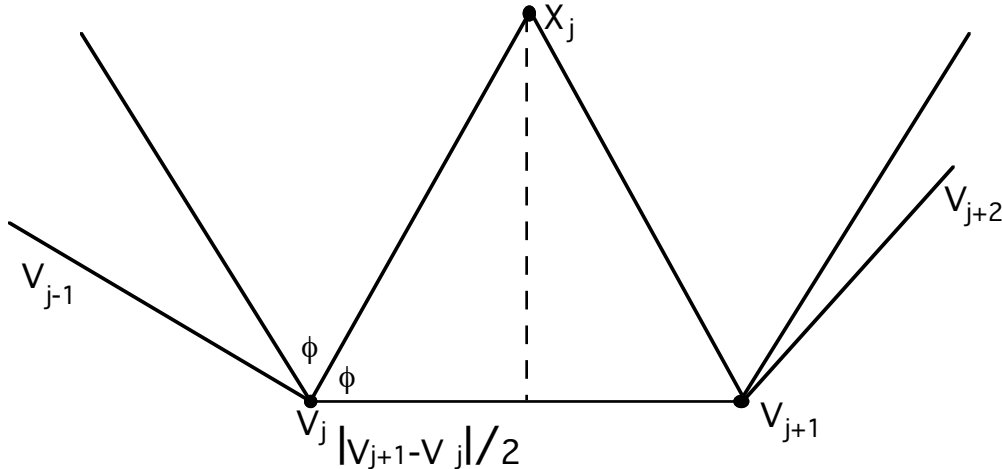

Figure N5.3. The calculation of the smoothing vector b corresponding to the operation \mathcal{T} (n,d) . Here $\phi = \pi(n - 2d)/2n$ is half the angle at the vertex of a regular (n/d) -gon and $|X_j V_j|/|V_{j+1} V_j| = 1/(2 \cos \phi)$.

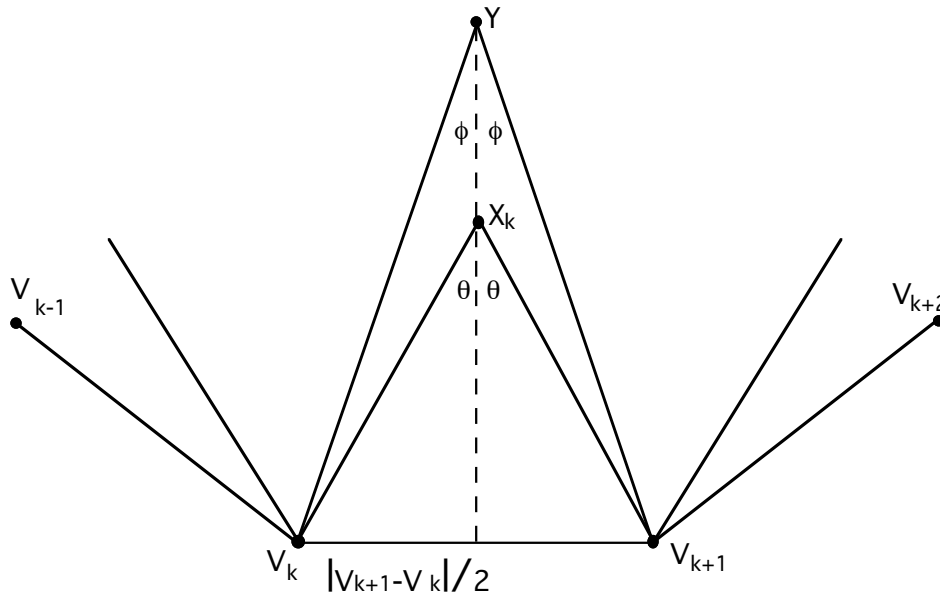

Figure N5.4. An illustration of the calculations in the proof of Theorem N5.3. The V 's are vertices of the regular (n/d_0) -gon $R(n,d_0)$, with center at Y . The point X_k is the center of the regular (n/d_j) -gon P_k which shares the edge $[V_k, V_{k+1}]$ with $R(n,d_0)$. X_k is a vertex of $\mathcal{T}_{n,d_j}(R(n,d_0))$.

the latter is given by the expression $\mu(n, d_j, d_0) = \cos \phi - \sin \phi \cot \theta$. Performing these steps for all the $n-2$ different values of d_j , $j = 1, \dots, n-2$, yields the theorem.

Comparing the result of Theorem N5.2 with the Napoleon-Barlotti theorem N2.3, we see that the latter is a special case of the former, in which the starting polygon P has only one nontrivial affine-regular component. Thus P has only two nontrivial regular components, the (n/d) - and $(n/(n-d))$ -regular components. Then $\mathcal{T}_{n,d}(P)$ is the polygon obtained in the Napoleon-Barlotti theorem, and it coincides with the $(n/(n-d))$ -symmetric component of P given by Theorem N5.2. The connection between this polygon and the regular components of P which was discussed following the proof of the Napoleon-Barlotti theorem, is the appropriate special case of the result of Theorem N5.2. Hence the illustrations in Figures N2.6 and N2.7 are also examples illustrating Theorem N5.2.

N6. The iteration of smoothing operations.

We have seen how the action of a suitable smoothing operation can produce more or less special polygons, either by itself or jointly with other smoothing operations, when applied to any polygon whatever, or to a polygons of some special kind. In this section we shall inquire what happens in the "general" case — that is, the case of an arbitrary transformation, acting on an arbitrary polygon. Naturally, there is not much that can be said in the absence of additional information. However, if the operation is iterated indefinitely, unexpected regularities of behaviour emerge. The full elucidation of these regularities is our central topic.

Let P be a n -gon, and let $P = \sum_{d=0}^{n-1} R(n,d)$ be its decomposition into regular components. For every smoothing vector $b = \{b_0, b_1, \dots, b_{n-1}\}$ the action of the smoothing operation $S(b)$ on P is the vertex-sum of the actions of $S(b)$ on the regular components $R(n,d)$ of P , that is,

$$S(b)P = S(b)\left(\sum_{d=0}^{n-1} R(n,d)\right) = \sum_{d=0}^{n-1} (S(b)R(n,d)) .$$

Thus the effect of $S(b)$ on P can be deduced from its effects on regular polygons. To find precisely what happens, we shall use the circulant matrix

$$C(b) = b_0\mathbf{I} + b_1Z + b_2Z^2 + \dots + b_{n-1}Z^{n-1}$$

introduced in Section N3; its first row is the vector b . Here and throughout this section, we shall consider the polygons as given in the complex plane, and allow the smoothing vectors and the matrices used to have complex components. In particular, putting $\omega = \exp(2\pi i/n)$, for $d = 0, 1, \dots, n-1$ we can write the standard regular (n/d) -gon $R_{n,d}$ in the form $\omega_d = (1, \omega^d, \omega^{2d}, \dots, \omega^{(n-1)d})^T$. As mentioned in Section N3 and easily proved, every vector ω_d is an eigenvector of every circulant matrix $C(b)$; let the corresponding eigenvalue be denoted by $\lambda_{b,d}$, or by λ_d if b is clear from the context. Thus $C(b)\omega_d = \lambda_d\omega_d$, and this has several important consequences, which can be used to justify the comments and explanations given below.

(1) The calculation of the eigenvalues λ_d of $C(b)$ does not require the solution of high-order equations. Instead, the eigenvalue λ_d of $C(b)$ associated with ω_d is given by $\lambda_d = \sum_{j=0}^{n-1} b_j\omega^{jd}$.

(2) Given the vector $\lambda = (\lambda_0, \lambda_1, \dots, \lambda_{n-1})$ of eigenvalues of a circulant matrix $C(b)$, the smoothing vector b can also be determined easily: If Ω is the matrix with entries $\omega_{j,k} = e^{-2\pi i(j-1)(k-1)/n}$ then $b = \frac{1}{n} \lambda \Omega$.

(3) The equation $C(b)\omega_d = \lambda_d \omega_d$ means that the image of the standard regular (n/d) -gon is another regular (n/d) -gon, obtained from the it by multiplication with the (possibly complex) number λ_d . Hence every (centered) regular (n/d) -gon will be mapped by $C(b)$ onto a regular (n/d) -gon by a dilation with ratio $\rho_d = |\lambda_d|$ followed by a rotation through angle $\phi_d = \arg \lambda_d$. (Compare Section N3, although there a different notation was used.)

The description given earlier of the action of $S(b)$ on a polygon P shows that the shapes of the polygons $S^m(b)P$ of $S(b)$ when $m \rightarrow \infty$, are determined by the non-trivial regular components of P and the eigenvalues of $S(b)$. There are many distinct possibilities, which are conveniently explored using the notation given below. Due to their easy interconvertibility, we shall usually specify a transformation either by the smoothing vector b , or by the vector $\lambda = (\lambda_0, \lambda_1, \dots, \lambda_{n-1})$ of eigenvalues of $C(b)$.

Let $D(P) = \{d_1, d_2, \dots, d_k\}$ be the set of integers for which the regular (n/d) -component of P is nontrivial. We denote by B^+ , B^- and B the sets of those d for which the dilation ratio $\rho_{b,d}$ is greater than 1, less than 1, or equal to 1, respectively. It is obvious that if $D(P) \cap B^+ \neq \emptyset$, then the n -gons $S^m(b)P$ will increase in size without bound, and if $D(P) \subset B^-$ then the n -gons $S^m(b)P$ will converge to the null-polygon. This is illustrated by the examples in Figure N6.1, which deal with the case $n = 5$ and the smoothing vector $b = (1, -i/2, 0, 0, i/2)$ considered at the beginning of Section N5. In this case the eigenvalues are $\lambda_1 = 1.951056516 = \rho_1$; $\lambda_2 = 1.587785252 = \rho_2$; $\lambda_3 = 0.4122147477 = \rho_3$; $\lambda_4 = 0.0489434837 = \rho_4$; hence $\phi_d = 0$ for all d . In part (a) $D(P) = \{1,2,3,4\}$, while in part (b) $D(P) = \{2,3,4\}$. Since in both cases $B^+ \neq \emptyset$, the iteration produces polygons of increasing sizes. In contrast, the polygon P in Figure N6.1(c) $D(P) = \{3,4\}$ and hence the iteration shrinks the successive polygons.

Thus the interesting cases are those where $D(P) \cap B \neq \emptyset$ and $D(P) \cap B^+ = \emptyset$. Since the eigenvalues of $C(\kappa b)$ are κ times those of $C(b)$, a suitable multiple of any smoothing vector is of that type. In Figure N6.2 we show such rescaled versions of the illustrations in Figure N6.1. The behavior in these cases is governed by the following considerations.

If $D(P) \cap B^+ = \emptyset$ and $D(P) \cap B = \{d_0\}$ is a singleton, then the sequence $S^m(b)P$ will be co-convergent with the sequence $S^m(b)R(n, d_0)$ of regular (n/d_0) -gons. (Two sequences of polygons are said to be co-convergent if their vertex-difference converges to the null-polygon.) In other words, the iterates will be increasingly closer in shape to regular (n/d_0) -gons of a certain fixed size, which differ from each other by rotation through a fixed angle ϕ_{d_0} ; see Figure N6.2. This case is somewhat special, in that $\phi_{d_0} = 0$, hence the iterates converge to a (fixed) regular polygon.

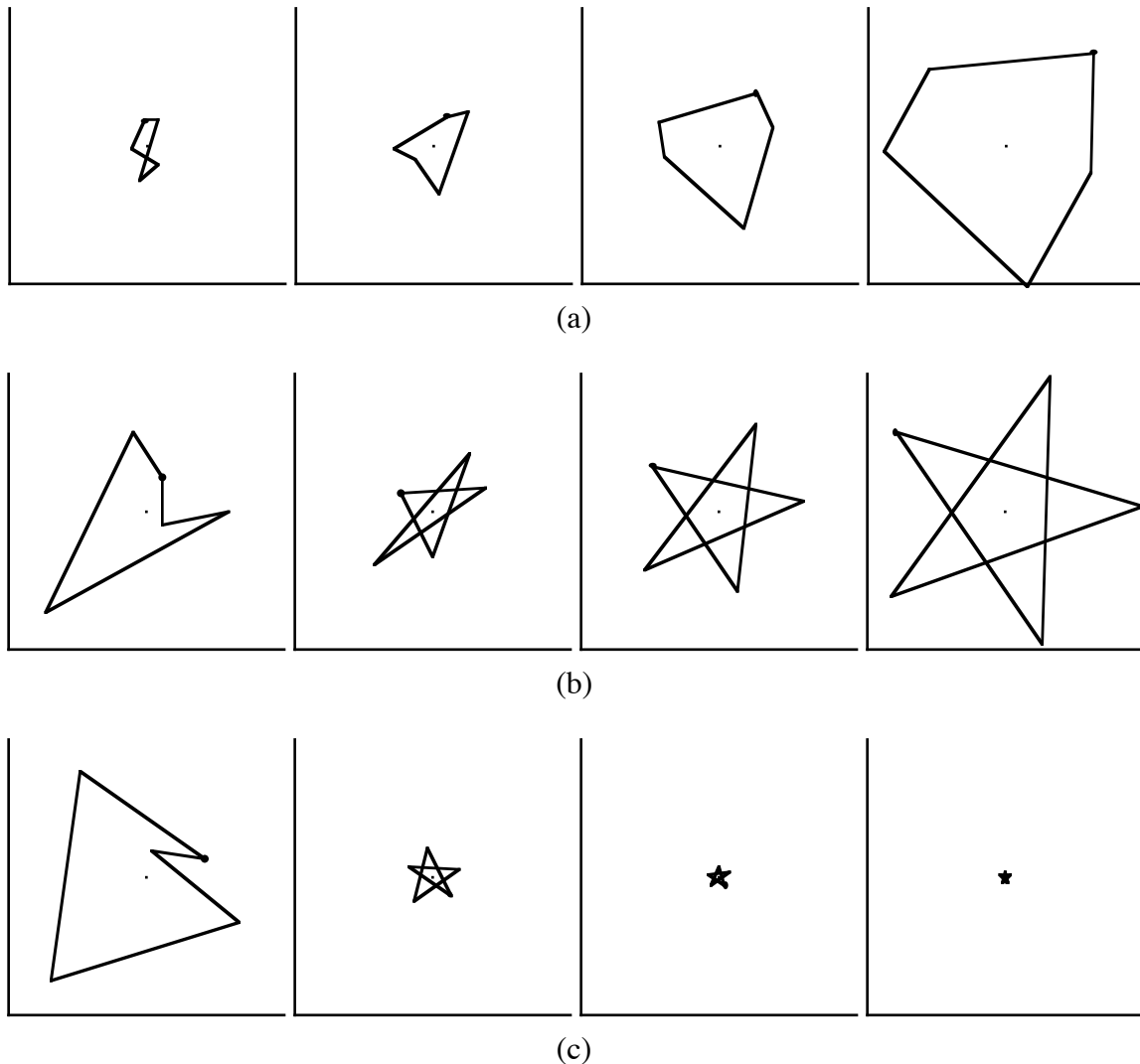
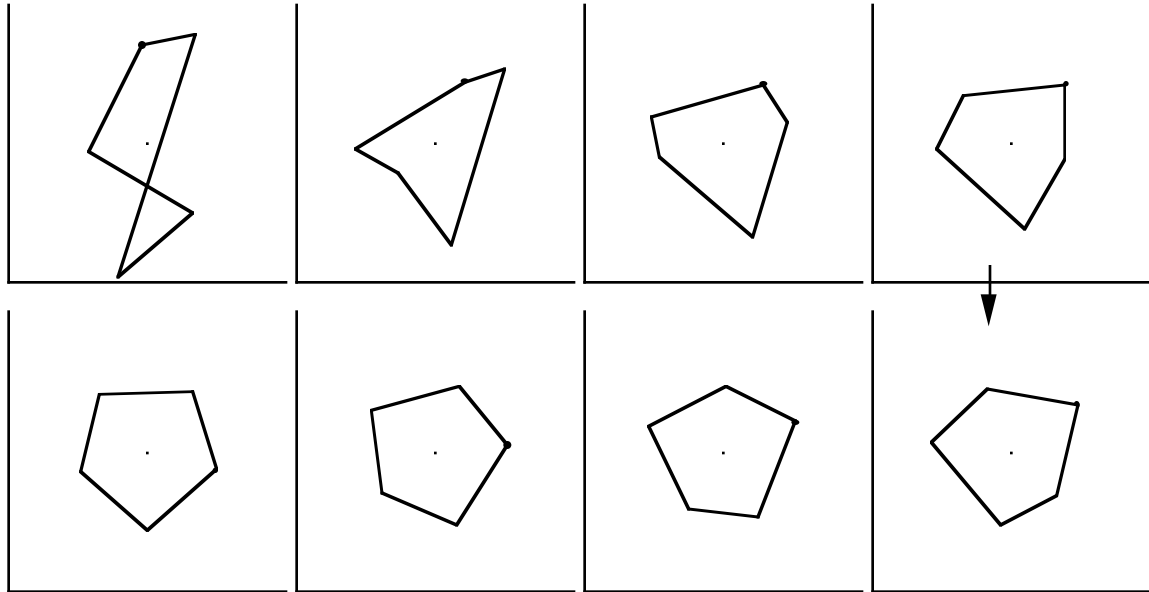
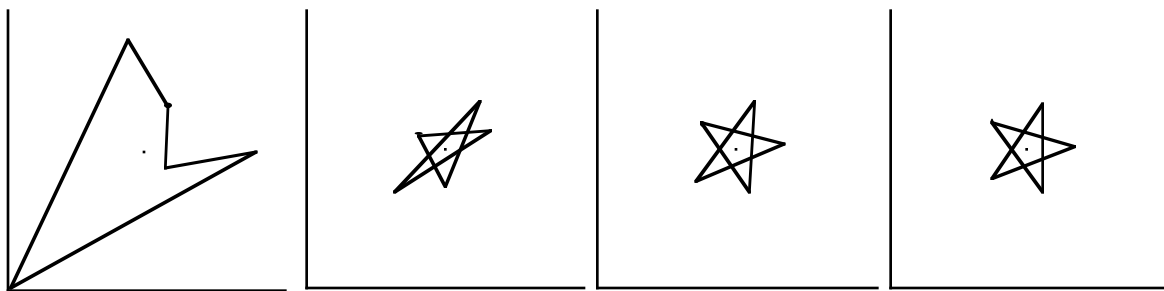

Figure N6.1. Iterations of the smoothing operation $S(b)$, with $b = (1, -i/2, 0, 0, i/2)$. The eigenvalues are $\lambda_1 = 1.951056516 = \rho_1$; $\lambda_2 = 1.587785252 = \rho_2$; $\lambda_3 = 0.4122147477 = \rho_3$; $\lambda_4 = 0.0489434837 = \rho_4$, and $\phi_d = 0$ for all d . The starting pentagon in (a) has nontrivial regular $(5/d)$ -components for all d ; the polygon in (b) is missing the $(5/1)$ -component, while the one in (c) is missing both $(5/1)$ - and $(5/2)$ -components.

In more general situations the angle ϕ_{d_0} is nonzero, and it may be either commensurable or incommensurable with 2π . In the former case, the sequence of iterates will be co-convergent to a periodic sequence of congruent regular (n/d_0) -gons, while in the latter the sequence of these polygons will be nonperiodic. The first is



(a)



(b)

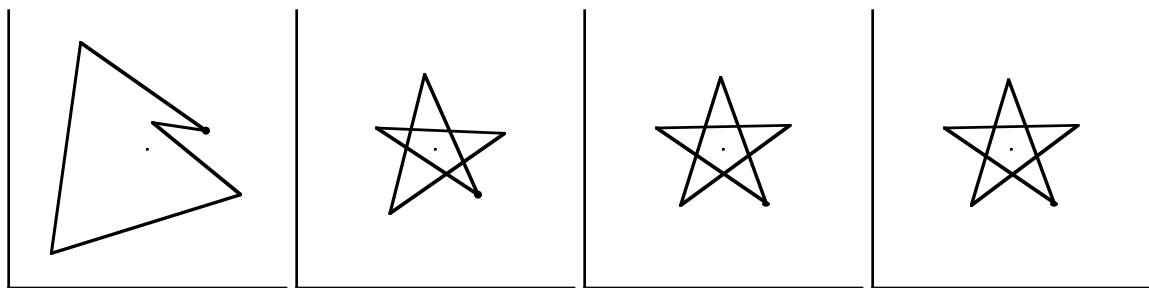

(c)

Figure N6.2. The rescaled operation $S(b)$, with $b = (1, -i/2, 0, 0, i/2)$ as in Figure N6.1. The rescaled smoothing vectors were in each case obtained by dividing b by the largest dilation factor applicable to the nontrivial regular components of the polygon.

illustrated by the (rescaled version of the) smoothing vector $b = (1, -i, 0, 0, 0)$, in which $d_0 = 1$, and the regular $(5/1)$ -component rotates through the angle of $\phi_1 = -9^\circ$ with each iteration; hence the period is 40; see Figure N6.3. The second possibility is illustrated in Figure N6.4, by the example of the (rescaled version of the) smoothing vector $b = (1, -i/2, 0, i/2, 0)$, for which the corresponding angle is $\phi_1 = -17.53300301\dots^\circ$. This angle appears to be (and may be conjectured to be) incommensurable with 360° , although we do not have a proof of this.

The possibilities become even more varied if $D(P) \cap B^+ = \emptyset$ and $D(P) \cap B$ contains more than one element. Then the two or more regular components of P that are determined by $D(P) \cap B$ will remain unchanged in size in all iterations, while the remaining regular (n/d) -components (for which $d \in B^-$) will shrink towards null-polygons.

If the smoothing vector is $b = (0.8 + 0.4i, 0.5236067977 - 0.7040294043i, 0.07639320225 - 0.1115073032i, 0.07639320225 + 0.3587208987i, 0.5236067977 + 0.05681580877i)$, which corresponds to the eigenvalues vector $\lambda = (2, 2, i, i, 0)$, then $B = \{2, 3\}$, and the action of $S(b)$ on any pentagon with trivial regular $(5/1)$ -component is as illustrated in Figure N6.5(a). Specifically, the $(5/4)$ -component is annihilated at the first iteration, and the $(5/2)$ - and $(5/3)$ -components are both rotated 90° ; hence after the first iteration all polygons are congruent, and the smoothing operation is periodic, with period 4. (Naturally, if there is any nontrivial $(5/1)$ -component present in the starting polygon, then it will grow without bound, overwhelming all the other components. If rescaled, the iterates would converge to a stationary regular $(5/1)$ -gon.) Figure N6.5(b) illustrates the smoothing transformation determined by the eigenvalues vector $\lambda = (2, 2, i, (1+i)/\sqrt{2}, 0)$, acting on the same polygon as in part (a). This transformation is periodic as well, but since the $(5/2)$ - and $(5/3)$ -components rotate at different speeds, its period is 8 and the 8 polygons within each period are all noncongruent.

The eigenvalues vector $\lambda = (1, 0, 3+4i, 4-3i, 0)/5$ shows still another possibility of behavior under iteration, illustrated in Figure N6.6, using the same polygon as in Figure N6.5. Here $B = \{2, 3\}$, $\phi_2 = 53.13010235^\circ$ and $\phi_3 = -36.86989765^\circ = 53.13010235^\circ - 90^\circ$. Therefore, after four iterations (beyond the initial one) the $(5/2)$ - and $(5/3)$ -components of P are in the same relative position, hence yield a congruent polygon. However, it is rotated through $4 \times 53.13010235^\circ = 212.5204094^\circ$; since one can confidently assume that this is not commensurable with 360° , the rotation is nonperiodic.

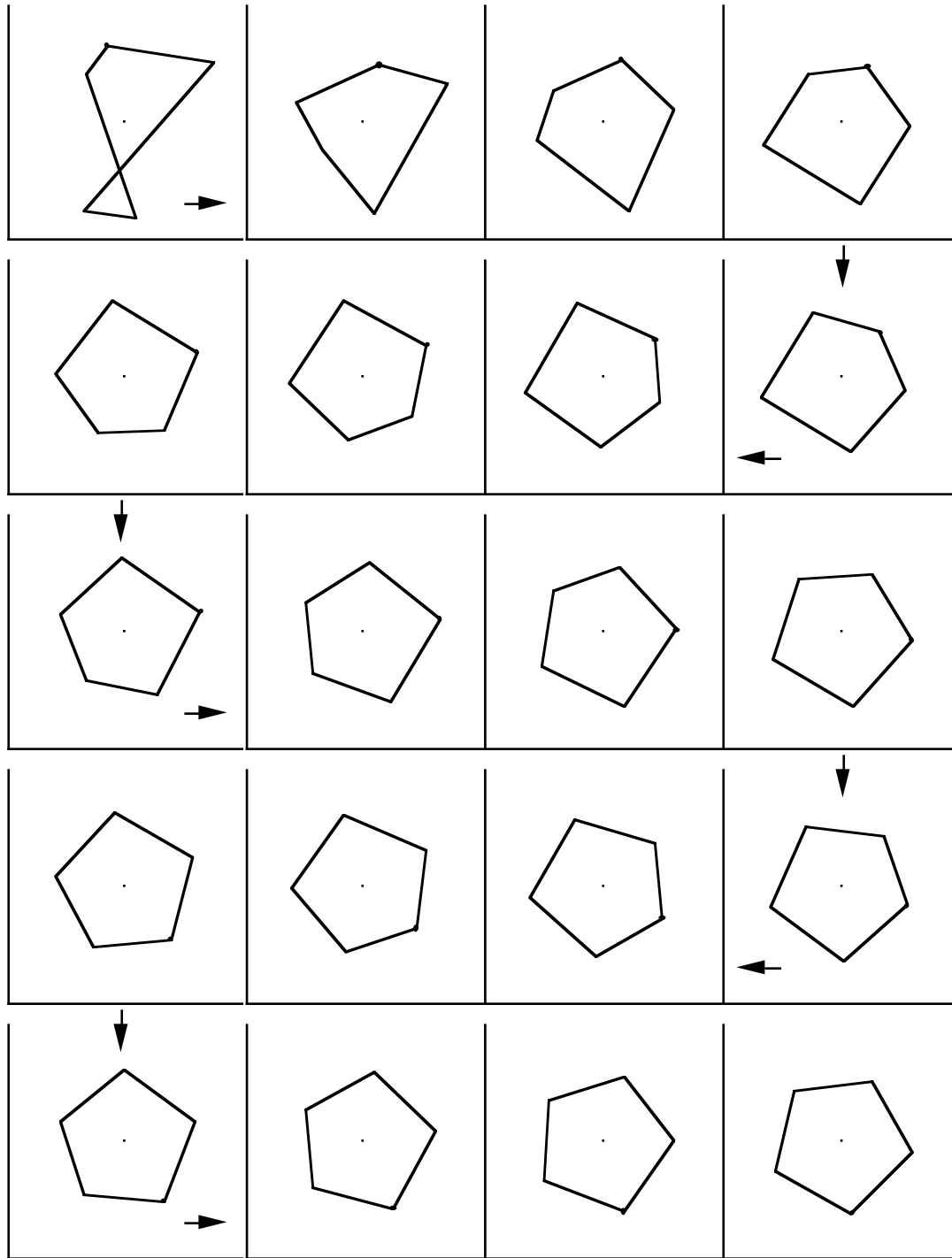

Figure N6.3. The iteration of the smoothing operation $S(b)$ with $b = (0.5062325629, -0.5062325629i, 0, 0, 0)$, a rescale of $(1, -i, 0, 0, 0)$, applied to a pentagon in which all regular components are nontrivial. Here $\lambda_1 = 0.9876883407 - 0.1564344651i$, $\rho_1 = 1$, $\phi_1 = -9^\circ$; $\lambda_2 = 0.8037885977 + 0.4095507465i$, $\rho_2 = 0.9021130327$, $\phi_2 = 27^\circ$; $\lambda_3 = 0.2086765282 + 0.4095507465i$, $\rho_3 = 0.4596495485$, $\phi_3 = 63^\circ$; $\lambda_4 = 0.0247767852 - 0.1564344651i$, $\rho_4 = 0.1583844403$, $\phi_4 = -81^\circ$. The iterates are co-convergent with a sequence of regular $(5/1)$ -gons, which rotate -9° with each iteration.

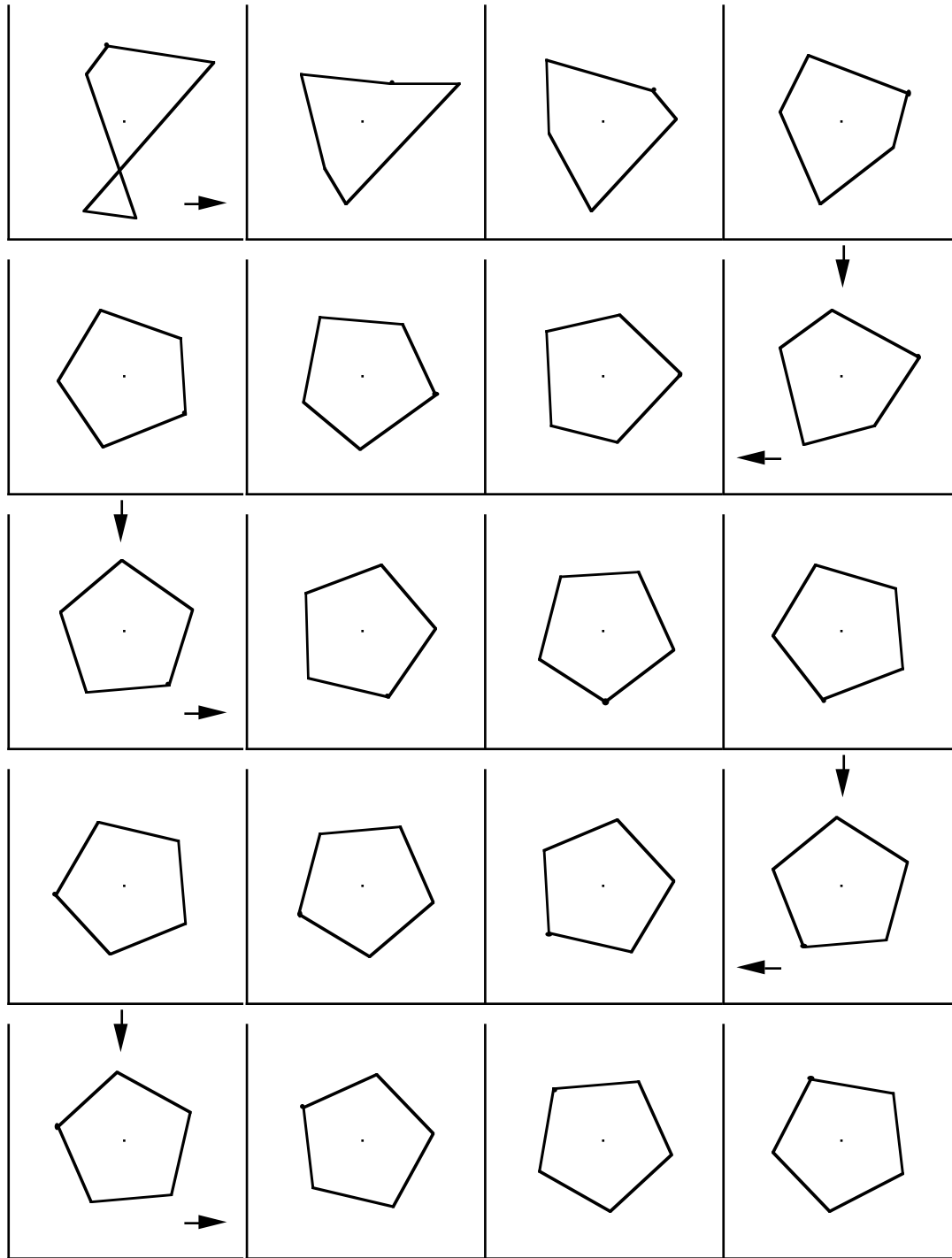

Figure N6.4. The iteration of the smoothing operation $S(b)$ with $b = (0.538901508, -0.269450754 i, 0, 0.269450754 i, 0)$, a rescale of $(1, -0.5 i, 0, 0.5 i, 0)$, applied to a pentagon in which all regular components are nontrivial. Here $\lambda_1 = 0.9535435829 - 0.3012551013 i$, $\rho_1 = 1$, $\phi_1 = -17.53300301^\circ$; $\lambda_2 = 0.441017792 + 0.3012551013 i$, $\rho_2 = 0.5340892518$, $\phi_2 = 34.33661506^\circ$; $\lambda_3 = 0.636785224 + 0.3012551013 i$, $\rho_3 = 0.704450181$, $\phi_3 = 25.31824382^\circ$; $\lambda_4 = 0.1242594332 - 0.3012551013 i$, $\rho_4 = 0.3258758088$, $\phi_4 = -67.58520093^\circ$. The iterates are co-convergent with a sequence of regular $(5/1)$ -gons, which rotate -17.53300301° with each iteration.

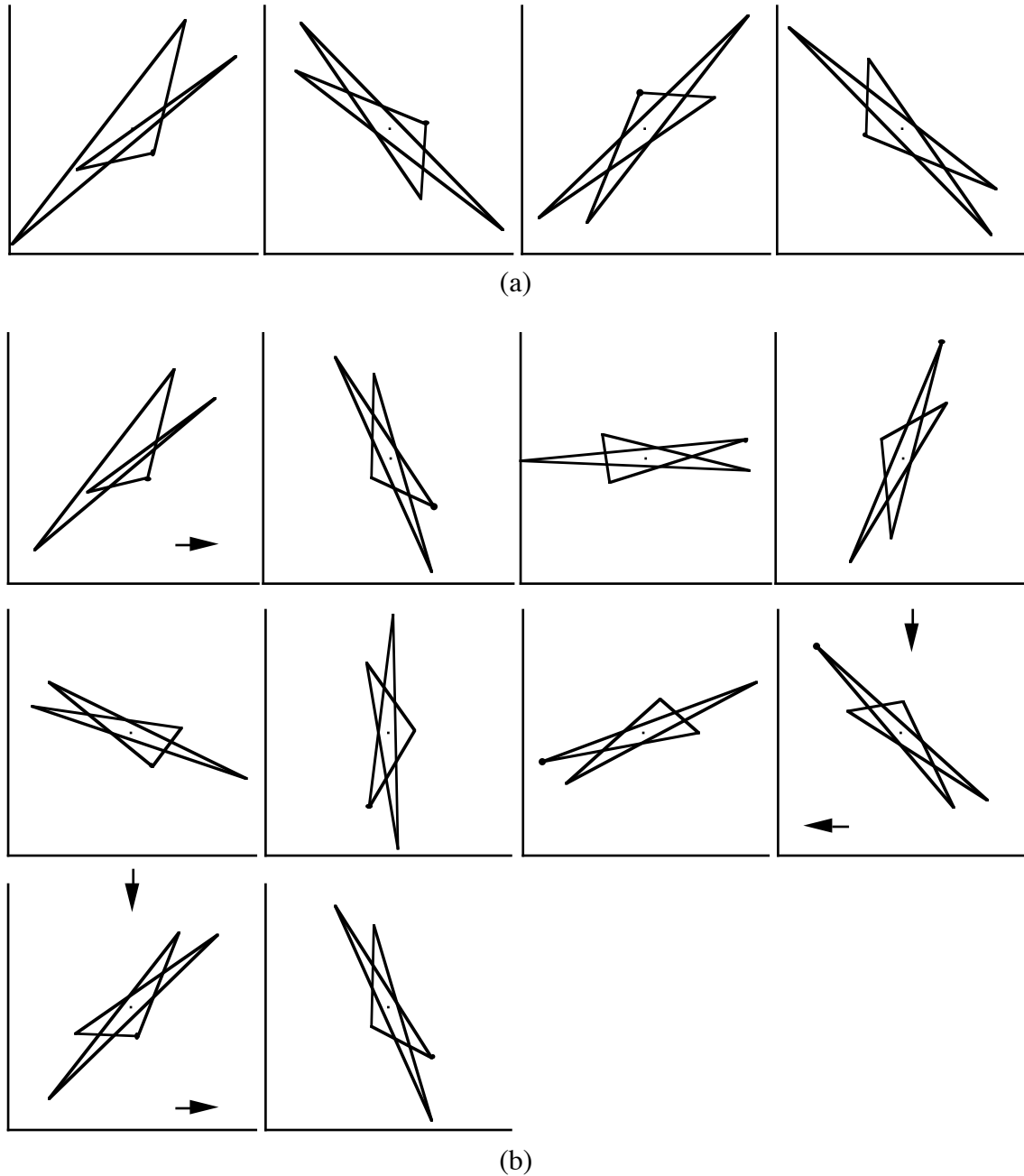

Figure N6.5. Two examples of smoothing operations periodic after the first iteration. The one in (a) has $\lambda = (2, 2, i, i, 0)$, while the one in (b) has $\lambda = (2, 2, i, (1+i)/\sqrt{2}, 0)$. The polygon is the same in both cases; it has trivial $(5/1)$ -component, and all other components nontrivial. In both cases the $(5/4)$ -component is annihilated in the first iteration, and the sequence of iterates is periodic. However, all these polygons (beyond the starting one) are congruent in (a), and the period is 4, while in (b) the period is 8 and the polygons within each period are noncongruent.

The eigenvalues vector $\lambda = (1, 0, (3+4i)/5, i, 0)$ leads to angles ϕ_1 and ϕ_2 that preclude any periodicity or congruence among the iterates.

If $D(P) \cap B$ contains three or more elements, analogous possibilities exist, and there seems to be no new possibilities of behavior. However, one other aspect — which first demonstrates itself already with $D(P) \cap B$ consisting of two elements, is the following. If (and only if) eigenvalues λ_d and λ_{n-d} are complex conjugates of each other (hence equal if real) then $\rho_d = \rho_{n-d}$ and $\phi_d = -\phi_{n-d}$. Therefore the regular (n/d) -component and the regular $(n/(n-d))$ -component are equally dilated by $S(b)$, and turned in opposite directions through the same angle. As we have seen earlier, this means that the affine-regular (n/d) -component is dilated by the same factor $\rho_d = \rho_{n-d}$ and subjected to the affine rotation through the angle ϕ_d . In other words, for such b it is enough to know the affine components of a polygon in order to be able to deduce the behavior under iteration. This is the type of smoothing vectors that has been investigated almost to the exclusion of all other kinds. The most frequent examples are the following ones, several of which have conventional names.

By far the earliest to be studied is the "midpoint map", first considered in some detail by Darboux [1878]. The midpoint map assigns to each vertex the midpoint of the edge following it. Cadwell [1953], [1966] and Berlekamp, Gilbert & Sinden [1965] independently provided thorough analyses of this transformation. It is characterized by $b = (1/2, 1/2, 0, \dots, 0, 0)$, and as is easily checked, $\lambda_d = (1 + e^{2\pi di/n})/2 = \cos \frac{\pi d}{n} e^{\pi i d/n}$. Hence this is in fact an affine operation, with $\rho_d = \cos \frac{\pi d}{n}$ and affine rotation through $\pi d/n$, for $1 \leq d \leq m = [n/2]$. It follows that $1 > \rho_1 > \rho_2 > \dots > \rho_m$, and so the sequence of iterates of $S(b)$ acting on a polygon P converges to the null-polygon, but if rescaled will be co-convergent with the nontrivial affine (n/d) -component of P having the smallest d . The traditional way of presenting this operation is illustrated in Figure N6.8.

The "parallelogram map" has $b = (-1, 1, 0, \dots, 0, 1)$; it assigns to each vertex V_j as image the fourth vertex of the parallelogram determined by V_{j-1}, V_j, V_{j+1} . The circulant matrix $C(b)$ has eigenvalues $\lambda_d = (2\cos \frac{2\pi d}{n} - 1) e^{2\pi i d/n}$; hence the dilation ratio is $\rho_d = |2\cos \frac{2\pi d}{n} - 1|$ for $1 \leq d \leq m = [n/2]$, and the affine rotation is through $\phi_d = 0$ or π , depending on whether $2\cos \frac{2\pi d}{n} - 1$ is positive or negative. Examples of the action of the parallelogram map are shown in Figure N6.9. The scaled iterates are co-convergent to an affine-regular (n/d) -gon for that value of d in $D(P)$ for which ρ_d is maximal. This map is interesting in that ρ_d is not a monotone function of d . For example, if $n = 17$ then $\rho_3 < \rho_2 < \rho_4 < \rho_1 < \rho_5 < \rho_6 < \rho_7 < \rho_8$.

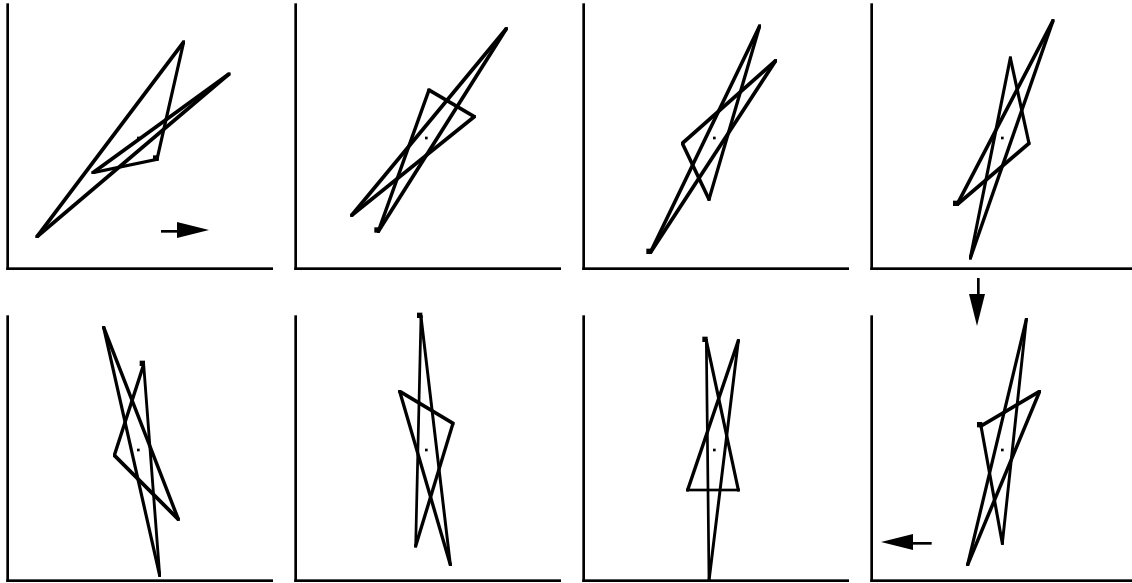

Figure N6.6. The same polygon as in Figure N6.5 is transformed by the smoothing operation with eigenvalues vector $\lambda = (1, 0, 3+4i, 4-3i, 0)/5$. Since the rotations of the $(5/2)$ - and $(5/3)$ -components differ by 90° , the shape of the pentagon is repeated after four iterations (beyond the first one), but this congruent pentagon is rotated through an angle that is incommensurable with 360° . Hence the transformation is nonperiodic, although only four shapes appear.

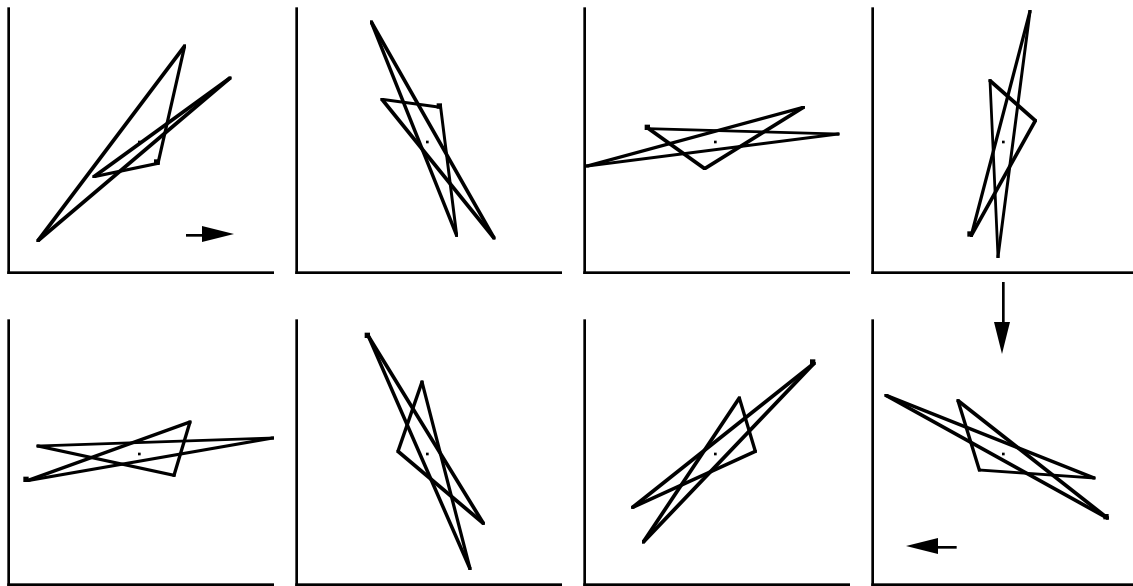
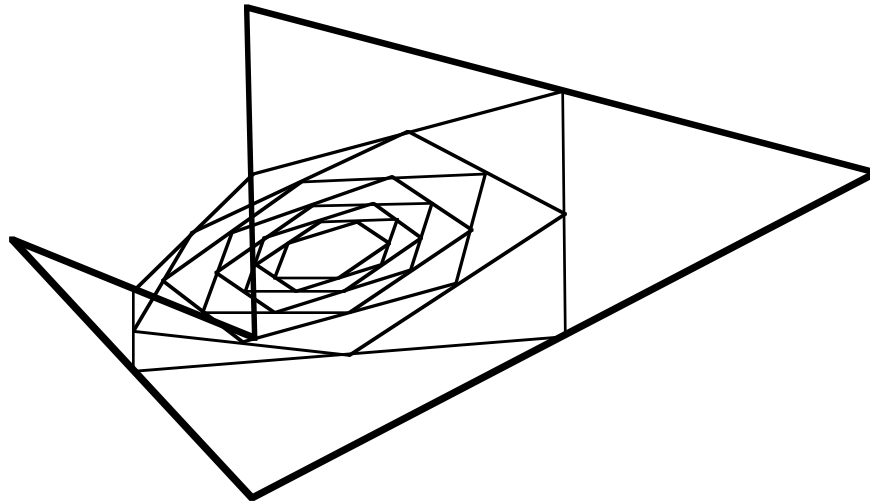
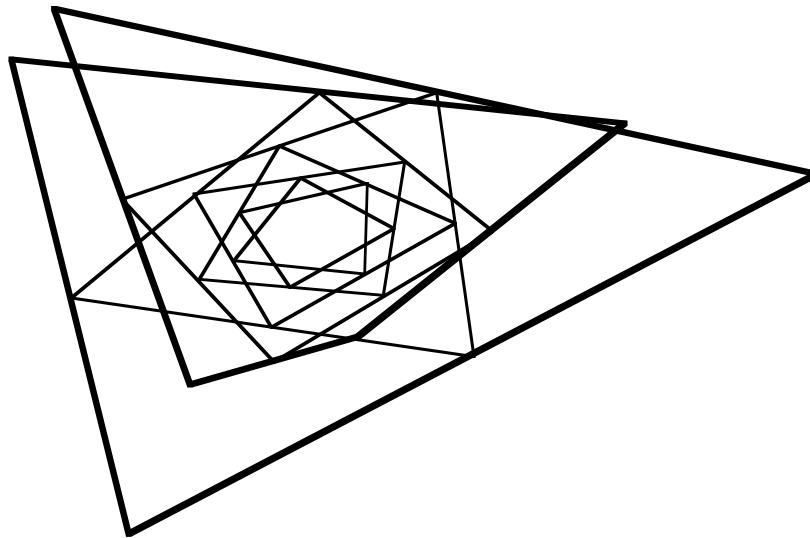

Figure N6.7. The same polygon as in two preceding figures is transformed by the smoothing operation with eigenvalues vector $\lambda = (1, 0, (3+4i)/5, i, 0)$. Here not both rotations (through $\phi_2 = 53.13010235^\circ$ and $\phi_3 = 90^\circ$) are commensurable with 360° , and neither is their difference; therefore there is no periodicity, and even no repetition of the shape. All polygons are different.

The "tangent map", with $b = (-1, 1, 0, \dots, 0)$, assigns to each vertex V_j the fourth vertex of the parallelogram determined by the centroid of the polygon, V_j , and V_{j+1} . By an easy calculation it can be shown that the eigenvalues are $\lambda_d = -1 + e^{2\pi id/n} = 2 \sin \frac{\pi d}{n} e^{i\pi(2d+n)/2n}$. Therefore the dilation ratio is $\rho_d = 2 \sin \frac{\pi d}{n}$ for $1 \leq d \leq [n/2]$, and the corresponding affine rotation is through the angle $\phi_d = \frac{(n+2d)\pi}{2n}$. The tangent map is illustrated in Figure N6.10.



(a)



(b)

Figure N6.8. Examples of the midpoint map, $b = (1/2, 1/2, 0, \dots, 0)$. The iterates of $S(b)$ acting on an n -gon P (drawn with heavy lines) converge to the null-polygon. If rescaled, they are co-convergent with the (nontrivial) affine (n/d) -component of P with smallest d . In (a) both $(5/d)$ -components are nontrivial, so the $(5/1)$ -component is the dominant one. In (b) the affine $(7/1)$ -component is trivial and the $(7/2)$ -component is dominant.

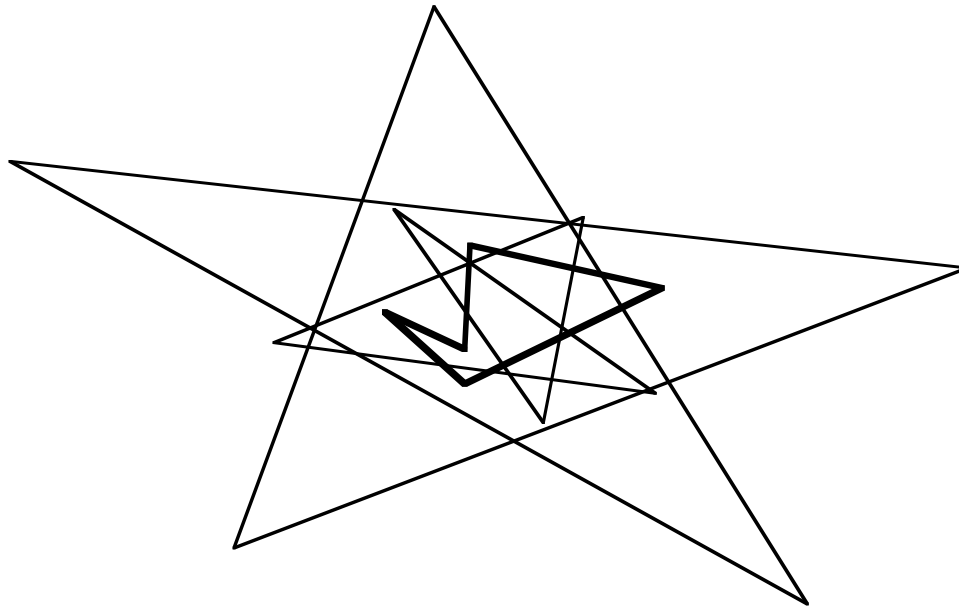

(a)

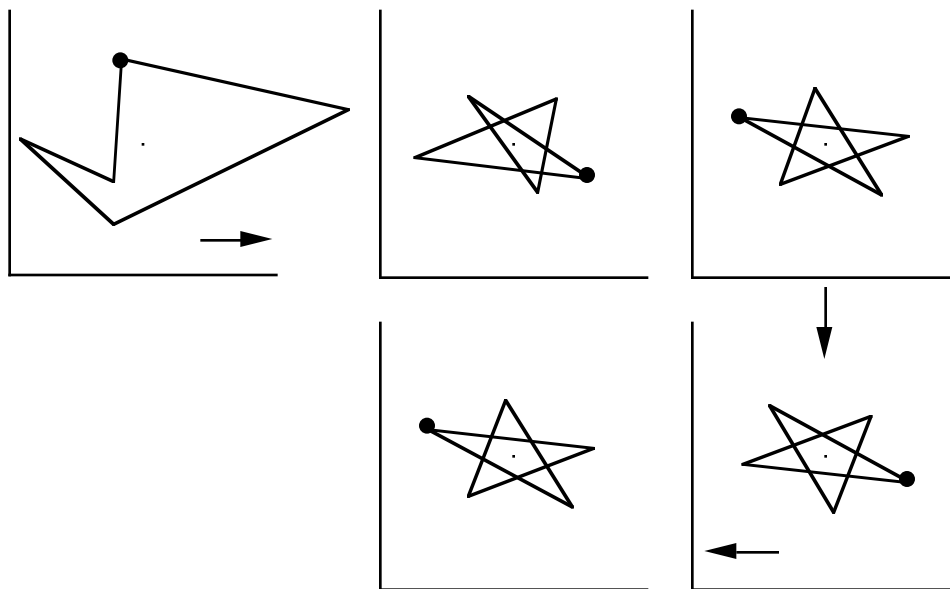

(b)

Figure N6.9. The action of the parallelogram map with $b = (-1, 1, 0, 0, 1)$ on a pentagon with both affine $(5/d)$ -components nontrivial; the root vertex is indicated by the large dot. In (a) the first two iterates under $S(b)$ are shown; in (b) the action of the rescaled smoothing vector $(1, -1, 1, 0, 0)/2.618033989$ is illustrated. Since $\rho_1/\rho_2 = 0.14589803\dots$, the affine $(5/1)$ -component is practically undetectable after two or three iterations. As $\phi_2 = 180^\circ$, the later iterations appear to be periodic with period 2.

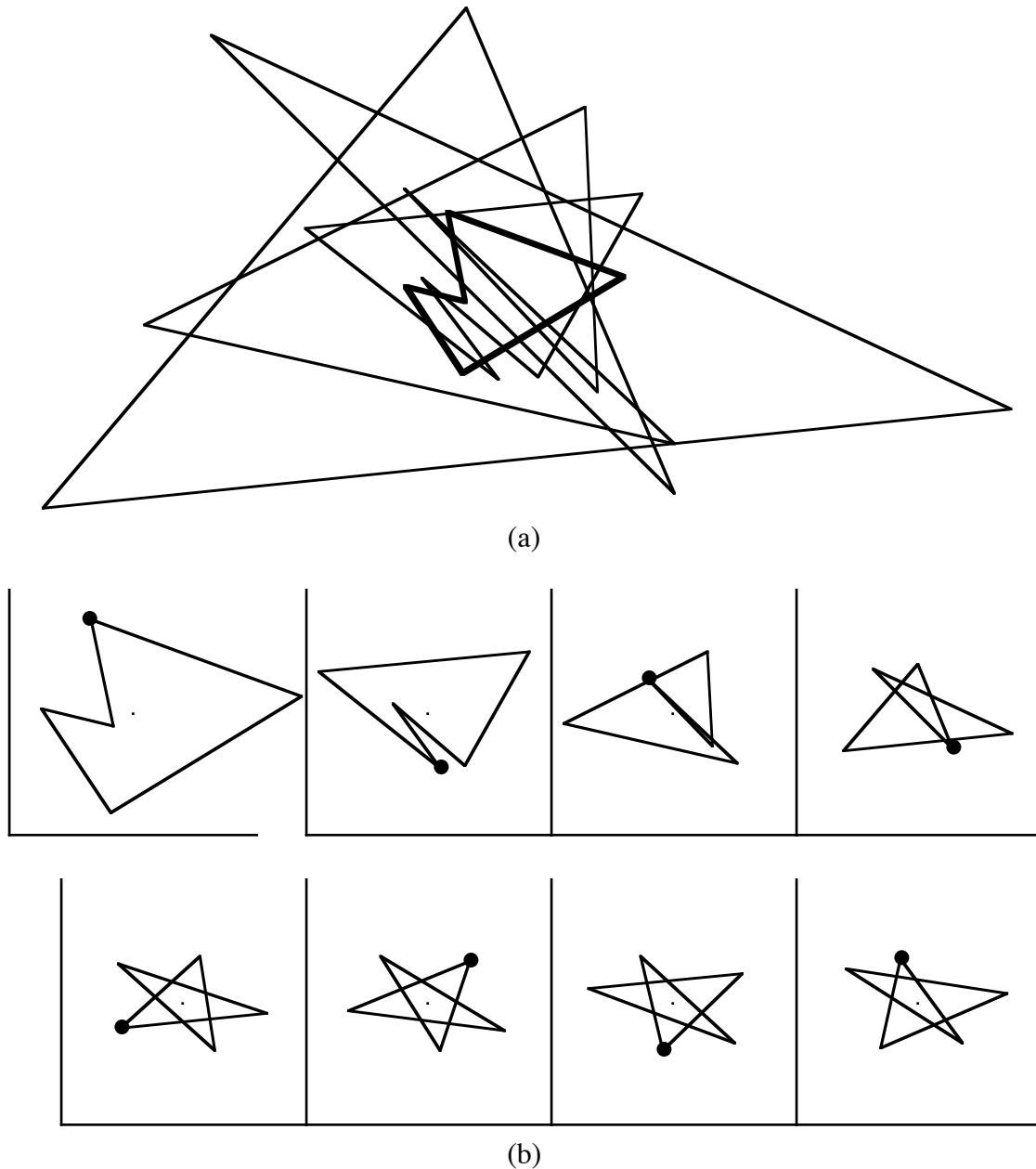

Figure N6.10. The action of the tangent map, determined for pentagons by $b = (-1, 1, 0, 0, 0)$, on a pentagon with both affine components nontrivial. (a) shows the first three iterates, and (b) shows the first seven iterates of the scaled transformation, for which the smoothing vector is $(-1, 1, 0, 0, 0)/1.9021130\dots$. Since the ratio $\rho_1/\rho_2 = 0.61803399\dots$ is not very small, the $(5/1)$ -component is eliminated only gradually. The sequence of scaled iterates is co-convergent with the affine $(5/2)$ -component, which affinely rotates through an angle of 162° at each step, and is therefore periodic with period 10.

Another interesting smoothing operation, which shows that unexpected possibilities exist even if only linear operations not involving rotations (that is, multiplication by complex numbers) are considered, has the smoothing vector $b = \{1+\tau, 1, \tau, 0, 0\}$, where $\tau = (1 + \sqrt{5})/2 = 1.618034\dots$ is the golden section number. All its dilation ratios ρ_d are 2.497212041, hence when rescaled no affine component changes size. The angles of affine rotation $\phi_1 = 49.61382244^\circ$ and $\phi_2 = -22.38617756^\circ$ seem to be not commensurable with 360° ; however, although the difference is 72° , since these are affine rotations that happen, in general, in distinct ellipses, there is no periodicity, see Figure N6.11. On the other hand, if only the *regular* (5/1)- and (5/2)-components are present in a polygon, then the rotation happens in circles and so the shape (including root) is repeated after five iterations. In fact, if the roots are disregarded, then all these polygons are rotationally equivalent. This is illustrated in Figure N6.12. If all dilation ratios are 1, and the affine rotations are all commensurable with 360° , then there is actual periodicity for all polygons. Such a situation is illustrated for $n = 5$ in Figure N6.13, where the smoothing operation is determined by the eigenvalues vector $\lambda = (0, e^{2\pi i/5}, e^{3\pi i/5}, e^{-3\pi i/5}, e^{-2\pi i/5})$ and so the period is 10.

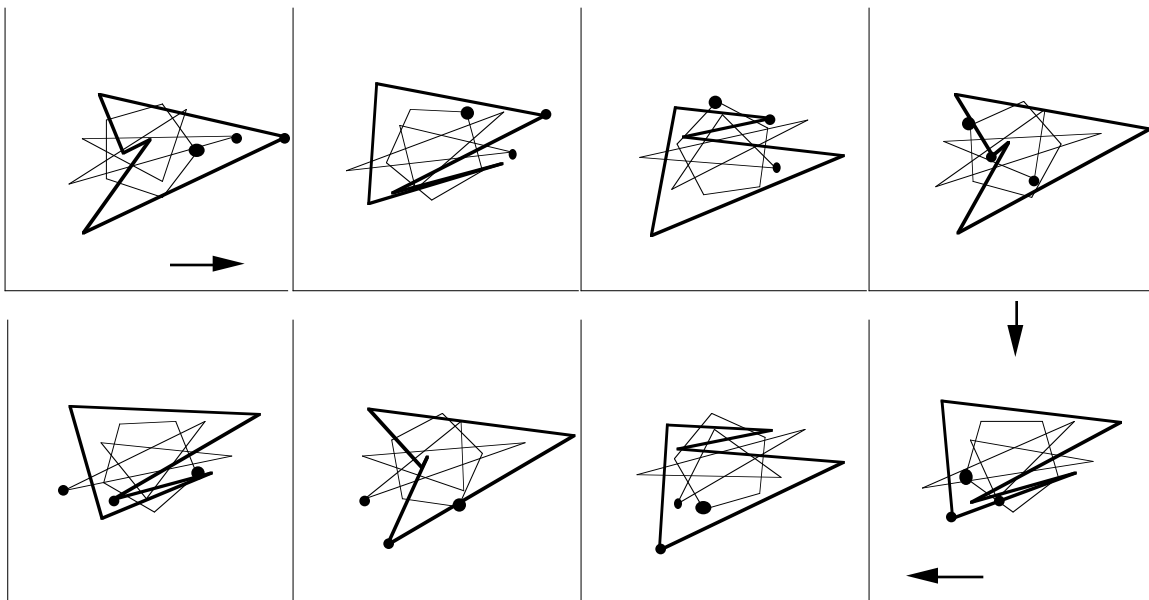

Figure N6.11. Iteration of the map $S(b)$ with $b = (1 + \tau, 1, \tau, 0, 0)$ where $\tau = (1 + \sqrt{5})/2 = 1.618033989\dots$ is the golden section, scaled appropriately, acting on a pentagon P . For the rescaled smoothing vector $\rho_1 = \rho_2 = 1$ therefore both affine components of P retain their size. The affine rotations are $\phi_1 = 49.61382244\dots^\circ$ and $\phi_2 = -22.38617756\dots^\circ$; they appear to be incommensurable with 360° and with each other, hence all iterated pentagons have affinely unrelated shapes.

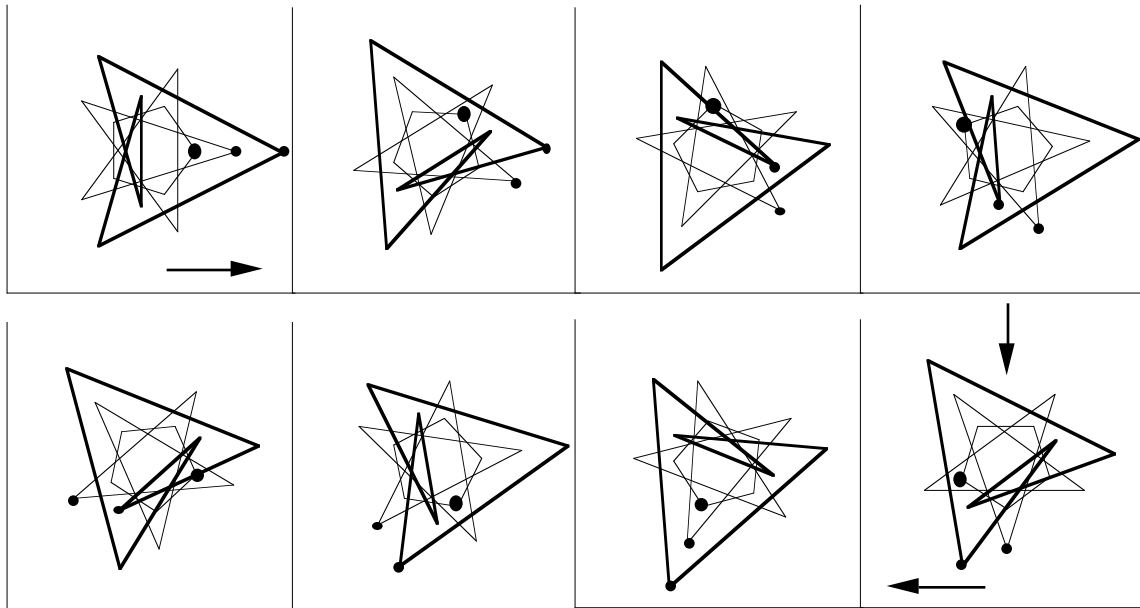

Figure 6.12. Iteration of the same map $S(b)$ as in Figure 6.11 applied to a pentagon P which is the vertex sum of a regular $(5/1)$ -gon and a regular $(5/2)$ -gon. The rooted iterated polygons in are rotationally equivalent after five steps, and the unrooted polygons are all rotationally equivalent.

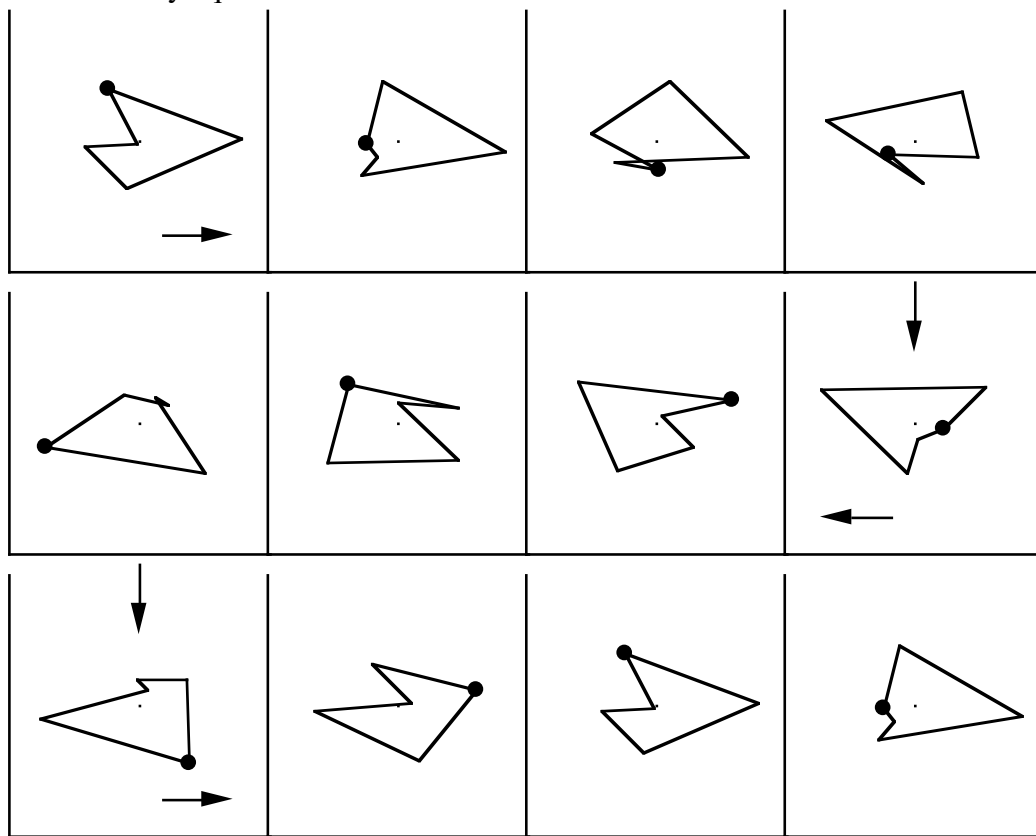

Figure N6.13. The operation determined by the smoothing vector $b = (0, 0.7236067977, -0.2763932022, 0, -0.4472135955)$ is periodic with period 10 for every pentagon.

N7. Polygons in three- and higher-dimensional spaces.

We shall now study some of the properties of n -gons in k -dimensional Euclidean space \mathbf{E}^k , as introduced in Section N1. The family $\mathbf{V}(n;k)$ of all centered rooted n -gons in \mathbf{E}^k is a real vector space under vertex addition $+$ and multiplication by real scalars; its dimension is obviously kn . As in the 2-dimensional case, $\mathbf{V}(n;k)$ can be made into an inner-product space, with all the usual properties.

In order to develop results similar to those in the plane, we have to define the special classes of polygons that led to the earlier results. For affine-regular polygons this is straightforward: Taking our cue from Theorem N2.2, we shall say that an n -gon $P = [V_0, V_1, \dots, V_{n-1}]$ is an affine-regular (n/d) -gon for some d such that $0 \leq d \leq [n/2]$ if and only if

$$v_{j+3} - v_j = \frac{\sin 3\pi d/n}{\sin \pi d/n} (v_{j+2} - v_{j+1}) \quad \text{for } j = 0, 1, \dots, n-1. \quad (1)$$

From this follows at once that every affine-regular (n/d) -gon in \mathbf{E}^k is contained in a 2-dimensional affine flat, and is therefore the image of a planar regular (n/d) -gon under an affine map.

From the linearity of condition (1) it follows that for every d with $0 \leq d \leq n/2$ the family $\mathcal{A}(n/d;k)$ of all rooted and centered affinely regular (n/d) -gons in \mathbf{E}^k is a vector subspace of $\mathbf{V}(n;k)$. More precisely, the dimension of $\mathcal{A}(n/d;k)$ equals $2k$ if $0 < d < n/2$, and it equals k if $d = 0$ or $d = n/2$. The second part of this statement is obvious, while the first part can be seen, for example, as follows. A rooted and centered regular (n/d) -gon P can be determined by one of its vertices (requiring k coordinates), and the plane of P (which requires additional $k-2$ parameters). Then the complete determination of a centered affine image of P (in its own plane) requires 2 additional parameters. Hence $\mathcal{A}(n/d;k)$ is of dimension at most $2k$. On the other hand, consider the $2k$ centered and rooted 1-dimensional affine-regular polygons $A(n/d;j)$ and $B(n/d;j)$ with vertices $v_i^{(n/d,j)} = (0, 0, \dots, 0, \cos \frac{2d\pi i}{n}, 0, \dots, 0)$ and $(0, 0, \dots, 0, \sin \frac{2d\pi i}{n}, 0, \dots, 0)$, respectively, where the only nonzero components are in the j th place, and $j = 1, 2, \dots, k$. For each d , these $2k$ polygons are mutually perpendicular (in the sense of the inner product); the polygons that correspond to the same k but to different values of d are orthogonal by elementary trigonometric relations. Hence the set of all these n -gons is linearly independent. Since there are altogether nk such polygons, the dimension of their span is nk . Therefore the dimension of each $\mathcal{A}(n/d;k)$ is $2k$ or k

as claimed, and the family consisting of all the affine-regular polygons $A(n/d;j)$ and $B(n/d;j)$ forms a basis of $\mathbf{V}(n;k)$.

We have just established a generalization of Theorem N2.1 to spaces of arbitrary dimension. As a consequence, we see that the corollaries concerning affine properties of polygons remain valid for polygons in \mathbf{E}^k . In particular, it follows that every centered n -gon is in a unique way the vertex sum of at most $n/2$ centered affine-regular polygons. But there is one novel aspect in comparison to the planar case: The affine-regular components of a polygon are, in general, contained in different planes. An illustration of this decomposition is provided in Figure N7.1.

The definitions and results of Section N3 that deal with affine-regular polygons remain valid in the present setting, with changes appropriate to the dimensions involved. This applies, in particular, to smoothing vectors, circulant matrices, (n/d) -regularizing and (n/d) -annihilating vectors. For example, an n -gon P is an affine-regular (n/d) -gon if and only if the vector $(1, -h, h, -1, 0, 0, \dots, 0)$ annihilates P , where $h = 1 + 2 \cos \frac{2\pi d}{n}$.

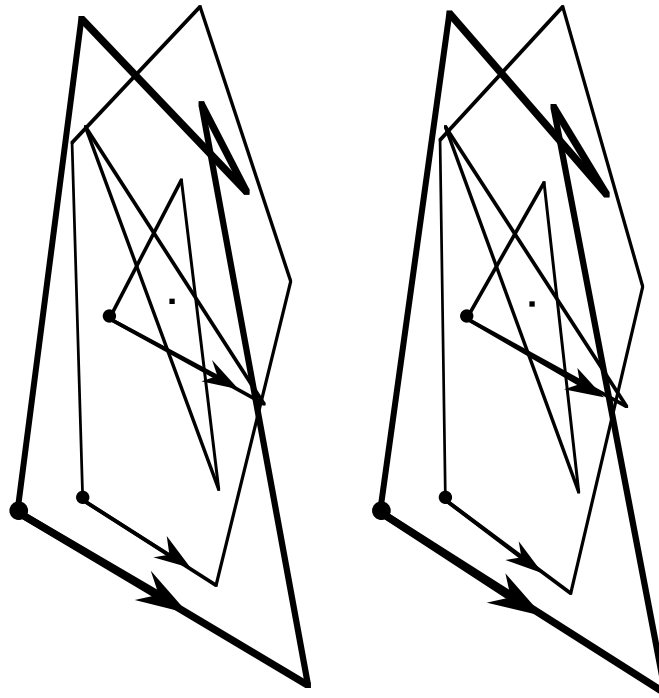

Figure N7.1. A stereoscopic pair of images, showing the decomposition of a nonplanar pentagon in \mathbf{E}^3 (shown by heavy lines) into two affine-regular pentagons. The arrowed edge of the pentagon is in the plane of the paper, the arrowed edge of the $(5/1)$ -gon points out of this plane upwards, and the one of the pentagram points downwards.

Very few such results are available in the published literature. Among the relevant publications are Douglas [1960] and Schoenberg [1981], [1982]. Douglas found $(5/1)$ - and $(5/2)$ -regularizing vectors $b^{(1)}$ and $b^{(2)}$ for pentagons in \mathbf{E}^3 , such that the resulting affine-regular polygons $A_1 = [U_0, U_1, \dots, U_4]$ and $A_2 = [W_0, \dots, W_4]$ together with the original pentagon $P = [V_0, \dots, V_4]$ have the following remarkable property: The points V_j, U_j, W_j and $(V_{j-2} + V_{j+2})/2$ are collinear for all j . This is illustrated in Figure N7.2. Douglas' result was established by simpler means in the works of Schoenberg. The smoothing vectors are $b^{(1)} = (-2, 0, 1+\sqrt{5}, 1+\sqrt{5}, 0)/2\sqrt{5}$ and $b^{(2)} = (2, 0, -1+\sqrt{5}, -1+\sqrt{5}, 0)/2\sqrt{5}$. Schoenberg found analogous regularizing vectors for heptagons.

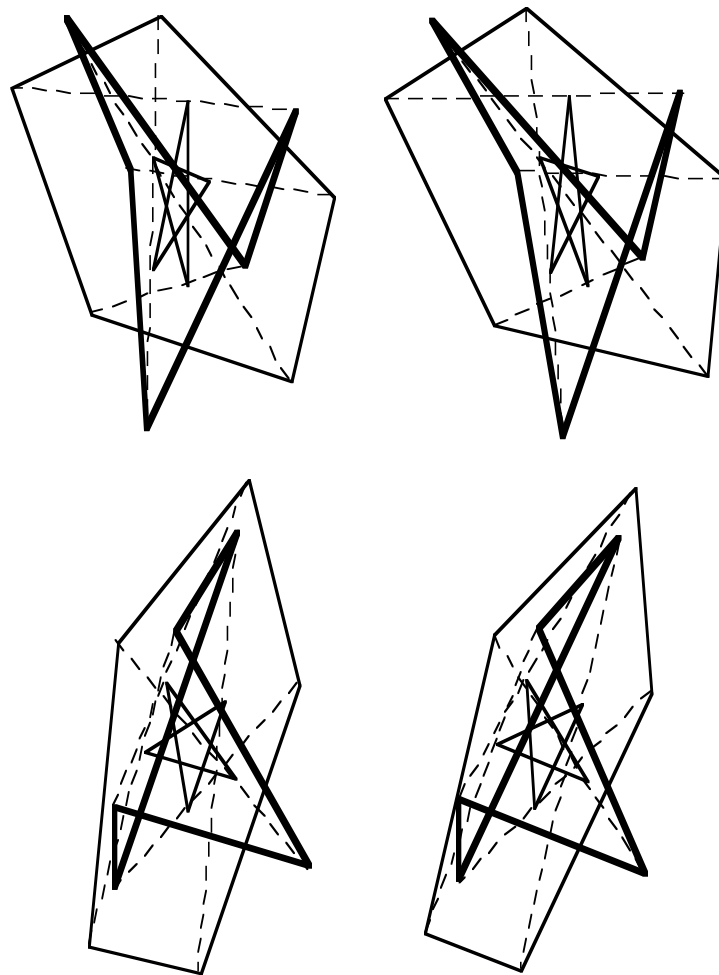

Figure N7.2. Two examples (each in stereoscopic pairs) of the two affine-regular pentagons associated with each pentagon in \mathbf{E}^3 by the method of Douglas and Schoenberg. The original pentagon in each example is shown in heavy lines, the affine-regular ones in thin lines. The collinearities mentioned in the text are indicated by the dashed lines.

It is worth mentioning that the affine-regular polygons resulting from the Douglas-Schoenberg construction are homothetic to the affine-regular components of the pentagon P . Specifically, $A_1 = \tau A(5,1)$ and $A_2 = \tau^{-1}A(5,2)$. The smoothing vectors $b^{(1)}$ and $b^{(2)}$ specified above for this construction can be easily expressed in terms of the basis vectors $c(n,d)$ and $s(n,d)$ of the space of $\mathbf{R}(n/d)$ of (n/d) -regularizing vectors, given on page N3.11. We have $b^{(1)} = c(5,0) - (\sqrt{5} + 1)c(5,1)$ and $b^{(2)} = c(5,0) + (\sqrt{5} - 1)c(5,2)$.

The analogous smoothing vectors for heptagons, given by Schoenberg, are: $b^{(1)} = (-0.086268, 0, 0.193842, 0.34929, 0.34929, 0.193842, 0)$, $b^{(2)} = (0.784851, 0, -0.435560, 0.543134, 0.543134, -0.435560, 0)$, $b^{(3)} = (0.301417, 0, 0.241717, 0.107574, 0.107574, 0.241717, 0)$. An example of the application of these vectors is given in Figure N7.3.

It is of some interest to speculate what is it that Douglas, and even more, Schoenberg, tried to do. The best one can deduce from their presentation is that they were looking for (n/d) -regularizing vectors $b^{(n,d)} = (b_0, b_1, \dots, b_{n-1})$ (for $n = 5$, and for $n = 7$, and $1 \leq d \leq n/d$) with certain special properties: (i) the b_1 and b_{n-1} components should equal 0; (ii) $b_j = b_{n-j}$ for each j with $1 \leq j \leq n/2$; and (iii) the sum of the components should be 1 (so that the result does not depend on the choice of the origin). It may be verified that condition (ii) amounts to requiring that $b^{(n,d)}$ is in the subspace of the space $\mathbf{R}(n/d)$ which is spanned by two of the three basis vectors of that space given on page N3.11, namely $c(n,0)$ and $c(n,d)$. Then the first condition can be used to determine the ratio of the coefficients of $c(n,0)$ and $c(n,d)$, and the last to determine their values. When these steps are carried out, we get $b^{(n,d)} = \frac{h}{n} \frac{c(n,0) - c(n,d)}{h}$, where $h = \cos \frac{2\pi d}{n}$. For $n = 5$ or 7 these values coincide with those given by Schoenberg, and may be assumed that this is the general results that he had in mind. The $(6/1)$ -regularizing vector $(-1, 0, 2, 3, 2, 0)$ mentioned on page N3.5, which was first noticed by Schoenberg [1987], is a scalar multiple of the vector $b^{(6,1)}$. By suitably modifying the factor h in the expression for $b^{(n,d)}$ one can get smoothing vectors satisfying conditions (ii) and (iii), but having another pair b_j, b_{n-j} of components equal to 0. The $(5/1)$ -regularizing vector $(1, \tau, 1, 0, 0)$, and the $(5/2)$ -regularizing vector $(1, 1-\tau, 1, 0, 0)$, also mentioned on page N3.5, are examples of this possibility (here $\tau = (1 + \sqrt{5})/2 = 1.618034\dots$ is the golden section constant).

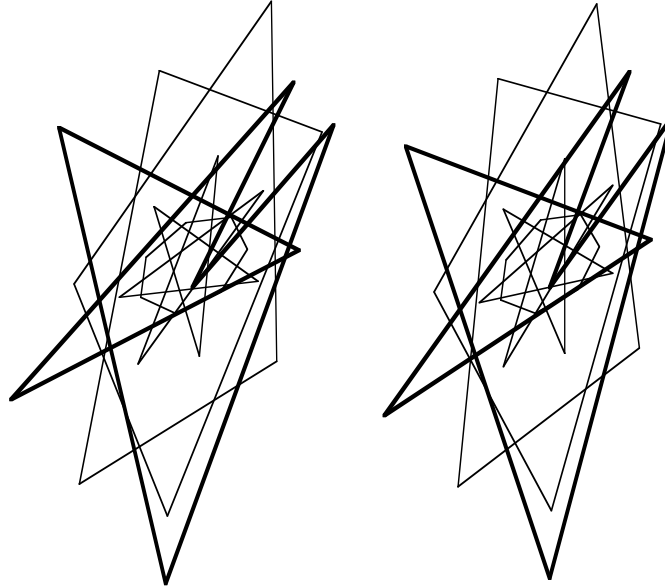

Figure N7.3. A heptagon, and the three affine-regular heptagons associated with it by the construction of Schoenberg.

References.

- J. Douglas, A theorem on skew pentagons. *Scripta Math.* 25(1960), pp. 5–9.
- I. J. Schoenberg, The harmonic analysis of skew polygons as a source of outdoor sculptures. In: *The Geometric Vein: the Coxeter Festschrift*, C. Davis, B. Grünbaum, F. A. Scherk, eds., pp. 165-176. Springer, New York, 1981.
- I. J. Schoenberg, The finite Fourier series IV: The harmonic analysis of skew polygons as a source of outdoor sculptures. Chapter 9 in: *Mathematical Time Exposures*. Math. Assoc. of America, Washington, DC, 1982.
- I. J. Schoenberg, Problem E3198. Birth of a regular hexagon. *Amer. Math. Monthly* 94(1987), p. 301; solution by J. van der Craats, *ibid.* 95(1988), p. 958.

N8. Some other polygons transformations.

A quite general class of transformations that map n -gons to n -gons associates with each k -tuple of consecutive vertices of the n -gon P a point obtained by some specific construction f ; the resulting n points form the image-polygon $P^* = f(P)$. Clearly, the smoothing operations we have been studying are of this kind, but there are many other possibilities that often lead to interesting results and unsolved problems. Here we shall present some of these.

1. Incenters.

Given an n -gon $P = [V_0, V_1, \dots, V_{n-1}]$, a new n -gon $I(P) = [V_0^*, V_1^*, \dots, V_{n-1}^*]$ is formed by the incenters V_j^* of the triangles $T_j = [V_{j-1}, V_j, V_{j+1}]$, for $j = 0, 1, \dots, n-1$. For $n = 4$ this is illustrated in Figure N8.1.

The sequence of n -gons $I^{(j)}(P)$, $j \rightarrow \infty$, where $I^{(0)}(P) = P$ and $I^{(j)}(P) = I(I^{(j-1)}(P))$ for $j > 0$, is convergent since every term is contained in the interior of the convex hull of the preceding one. For the same reason, the limit must be either a single point or a segment. This is the same situation as can be found in various other constructions. However, in most of the other cases the limit is, in fact, always a point. This contrasts to the situation considered here, where the limit appears to be a segment; see the first two illustrations in Figure N8.2.

The easiest example in which the convergence to a segment can be proved (instead of it only being suggested by diagrams) is that of rectangles, see Figure N8.3. Using elementary results on angle bisectors, it is not hard to calculate that if P is an a by b rectangle, with $a > b$, then $P^* = I(P)$ is an a^* by b^* rectangle, concentric with P and having sides parallel to those of P , where

$$a^* = \frac{a(a-b+c)}{(a+b+c)} \quad \text{and} \quad b^* = \frac{b(-a+b+c)}{(a+b+c)},$$

and $c = \sqrt{a^2 + b^2}$ is the length of the diagonal of P . This implies the unexpected relation $a^* - b^* = a - b$, which shows that the sequence $I^{(j)}(P)$ converges to a segment of length $a - b$. For squares, and some other quadrangles, the limit is a point, while for the remaining quadrangles it is a segment.

Even in case $n = 4$ it is not known how to characterize the quadrangles P for which $I^{(j)}(P)$ converges to a point, or how to determine the length of the limit segment for nonrectangular quadrangles for which $I^{(j)}(P)$ converges to a segment. Nor is it known what happens if in case the limit is a point, the incircle map is combined with rescaling to keep the diameter (or some other size measurement) constant.

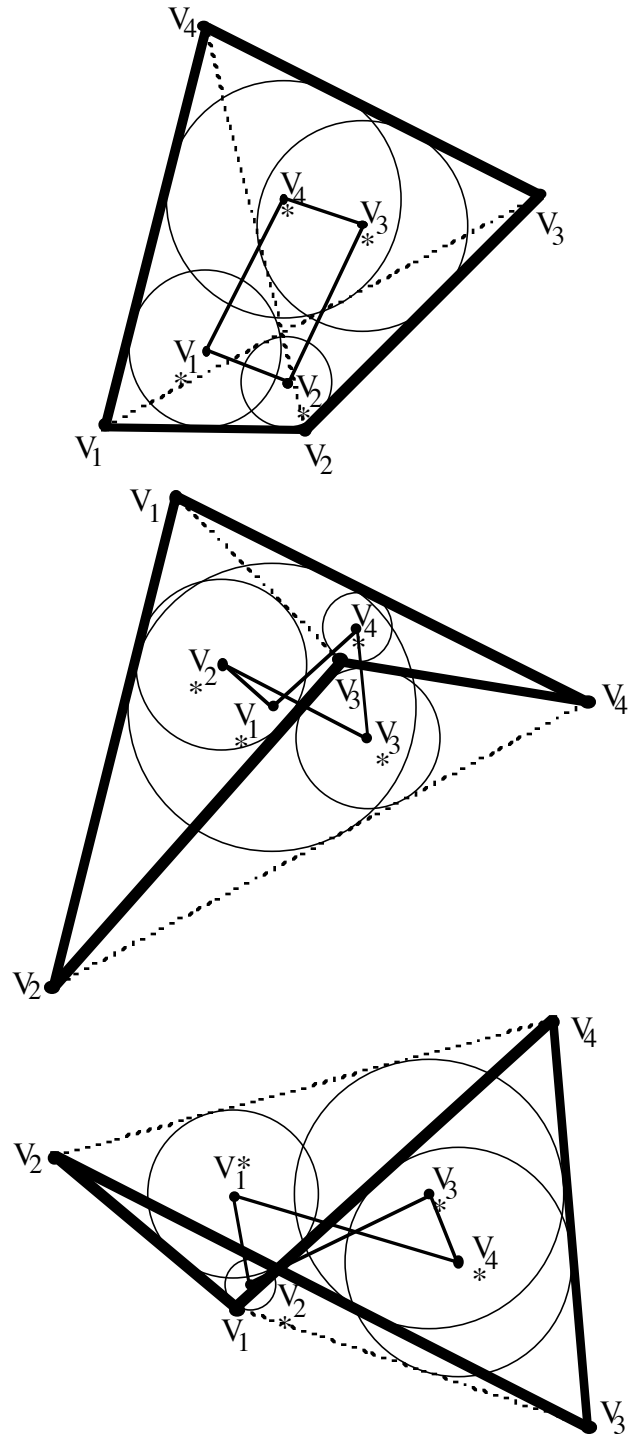

Figure N8.1. Examples of the incircle construction. In each, the quadrangle P is shown with heavy lines, its diagonals with dotted lines, and the derived quadrangle with thin lines. The four circles inscribed into the triangles T_j are also shown.

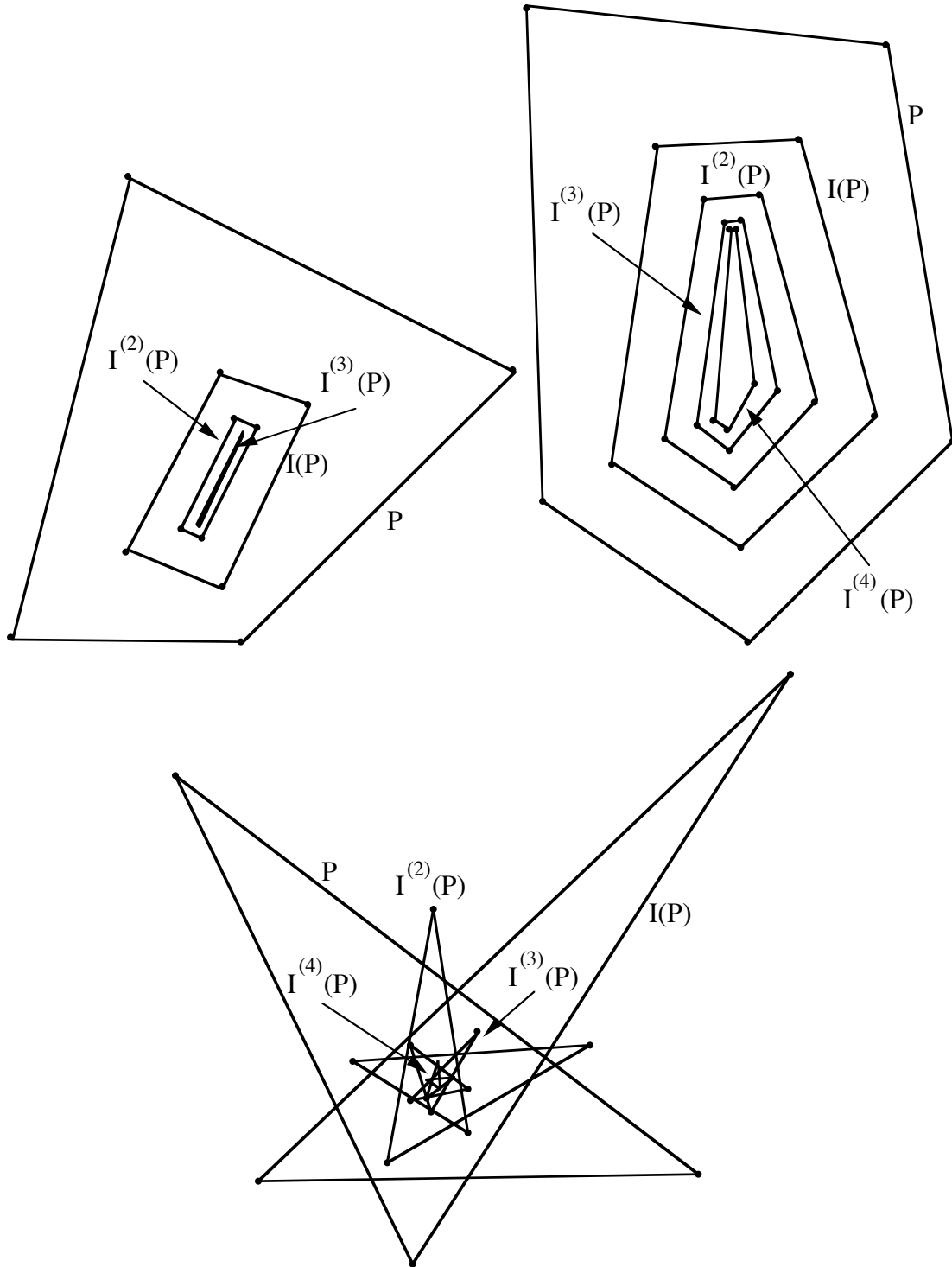

Figure N8.2. Iterations of the incircle map seem to lead to limits which are either segments or points.

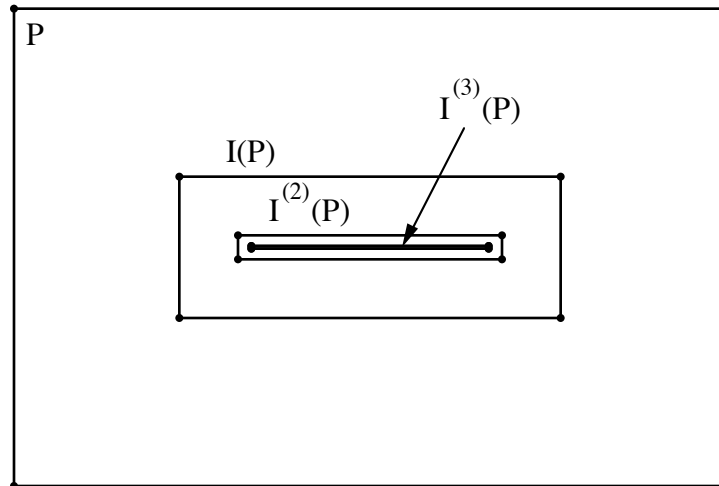

Figure N8.3. Iterations of the incenter transformation applied to a rectangle lead to rectangles which converge to a segment. All rectangles in the sequence have same difference of length of their sides.

2. Orthocenters.

Given an n -gon $P = [V_0, V_1, \dots, V_{n-1}]$, a new n -gon $P^* = O(P) = [V_0^*, V_1^*, \dots, V_{n-1}^*]$ is formed by the orthocenters V_i^* of the triangles $T_j = [V_{j-1}, V_j, V_{j+1}]$, for $j = 0, 1, \dots, n-1$. For $n = 4$ this is illustrated in Figure N8.4.

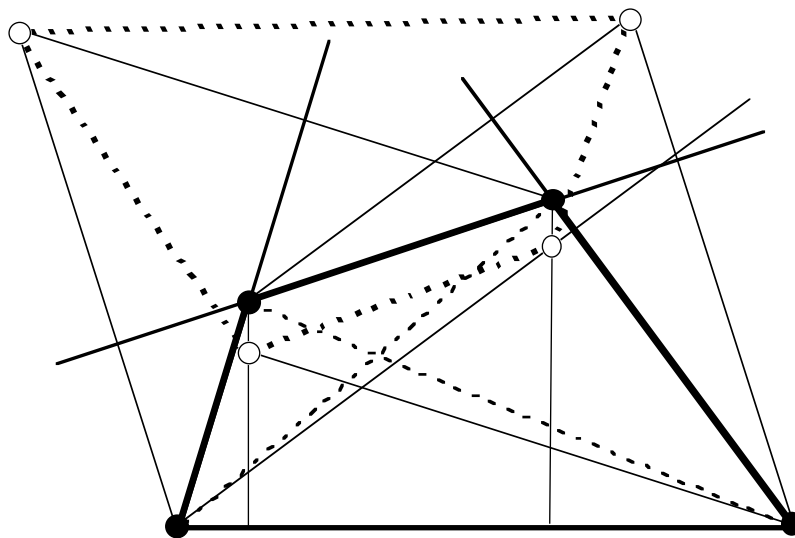

Figure N8.4. Construction of the polygon $O(P)$ (heavy dotted line) from the quadrangle P (heavy lines). Only two altitudes (thin solid lines) are shown for each of the four triangles, each of which is determined by two adjacent sides of the quadrangle and one diagonal (dotted lines).

The main result, illustrated in Figure N8.5, concerns the unexpected result of the action of $O(P)$ on quadrangles. The result is:

Theorem. For every quadrangle P , the quadrangle $P^* = O(P)$ is affinely equivalent to P under an area-preserving affinity $\alpha = \alpha_P$.

Proof. The proof is a straightforward exercise in analytical geometry. It is preferably carried out using some symbolic algebra software, but the steps can be given easily enough. Starting with vertices given as $V_0 = (p, q)$, $V_1 = (1, 0)$, $V_2 = (r, s)$, $V_3 = (0, 1)$ (this is the selection of coordinate system which worked best for me), we find that the vertices of $O(P)$ have coordinates as follows:

$$V_0^* = \left(\frac{q + pq - q^2}{-1 + p + q}, \frac{p - p^2 + pq}{-1 + p + q} \right),$$

$$V_1^* = \left(\frac{-pq + pqr + q^2s + rs - prs - qs^2}{-q + qr + s - ps}, \frac{-p + p^2 + r - p^2r - r^2 + pr^2 - pqs + qrs}{-q + qr + s - ps} \right),$$

$$V_2^* = \left(\frac{s + rs - s^2}{-1 + r + s}, \frac{r - r^2 + rs}{-1 + r + s} \right),$$

$$V_3^* = \left(\frac{q - q^2 + pqr - s + q^2s - prs + s^2 - qs^2}{p - r + qr - ps}, \frac{pq - p^2r + pr^2 - pqs - rs + qrs}{p - r + qr - ps} \right).$$

The intersection points of the diagonals of the two quadrangles are

$$D_P = \left(\frac{p - r + qr - ps}{p + q - r - s}, \frac{q - qr - s + ps}{p + q - r - s} \right) \text{ and}$$

$$D_{O(P)} = \left(\frac{q + pq - q^2 - s - rs + s^2}{p + q - r - s}, \frac{p - p^2 + pq - r + r^2 - rs}{p + q - r - s} \right).$$

From this it follows that

$$\frac{V_2 - V_0}{V_2 - D_P} = \frac{V_0^* - V_2^*}{V_0^* - D_{O(P)}} = \frac{-p - q + r + s}{-1 + r + s} \quad \text{and} \quad \frac{V_3 - V_1}{V_3 - D_P} = \frac{V_1^* - V_3^*}{V_1^* - D_{O(P)}} = \frac{-p - q + r + s}{-p + r - qr + ps},$$

which shows the affine equivalence of P and $O(P)$. A calculation of areas shows that $\text{Area}[V_1, V_2, V_3, V_4] = \text{Area}[V_0^*, V_1^*, V_2^*, V_{n-1}^*] = -p - q + r + s$, thus completing the proof that α_P is an area-preserving affinity.

Figure N8.5 seems to indicate that unless the vertices of P are in very special positions (such as coinciding with the vertices of a rectangle) iterations of the orthocenters map will produce quadrangles the diameters which are increasing without

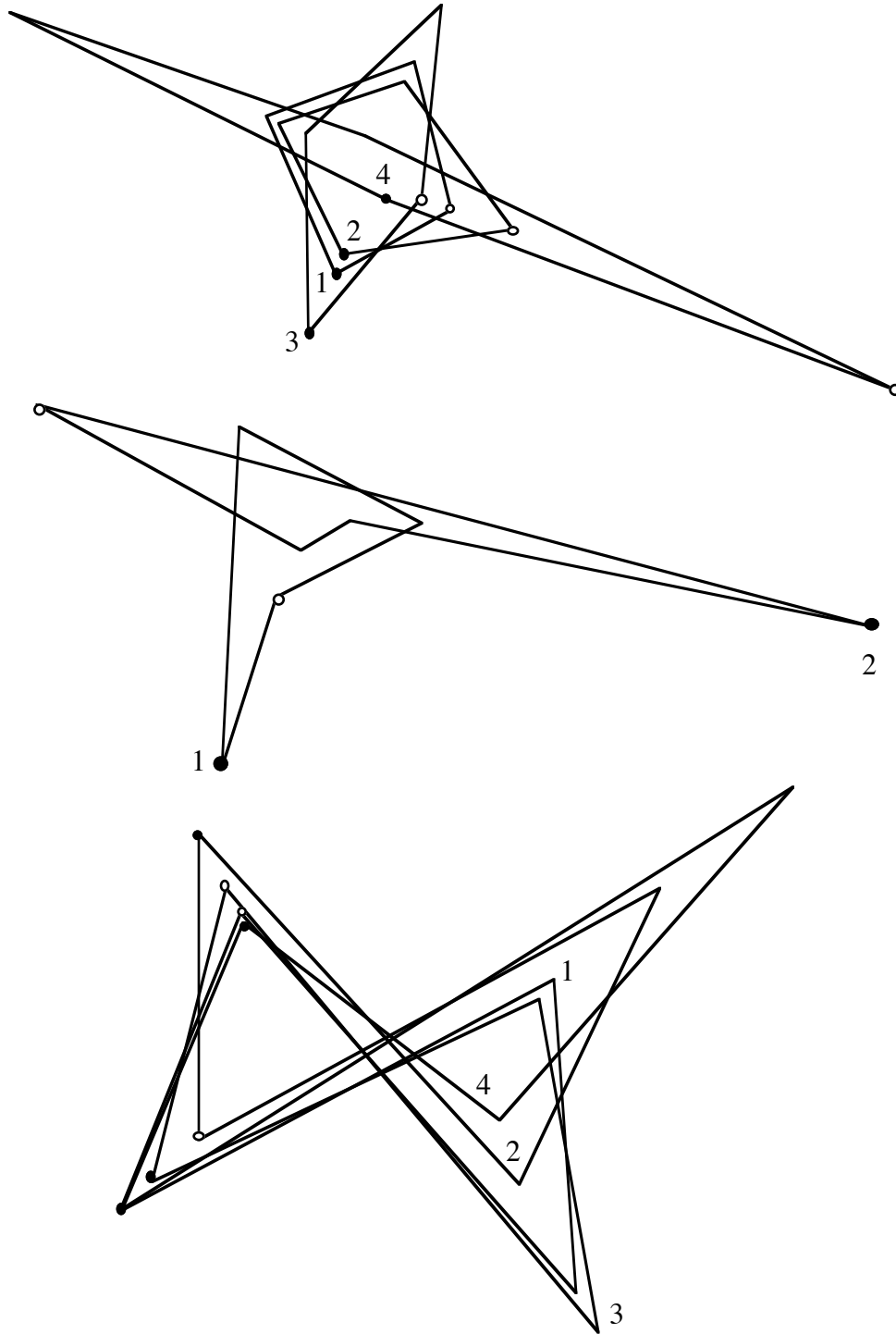

Figure N8.5. Three examples of iterations of the operation O . The starting quadrangle is labeled 1, and the other numerals indicate the iterates. Examples like these led to the idea of affine equivalence of the quadrangles P and $O(P)$.

bounds. However, this is not the case. One can argue that on grounds of continuity there have to exist other quadrangles which do not change diameter under the orthocenters map. In fact, it is rather easy to produce explicit examples; the one in Figure N8.6 differs very little from the quadrangle in Figure N8.4. The characterization of all quadrangles P that are congruent to $O(P)$ is an open problem

Among other open problems is the question of characterizing α_P in terms of the quadrangle P . Also, nothing seems to be known about properties of $O(P)$ for n -gons P with $n \geq 5$.

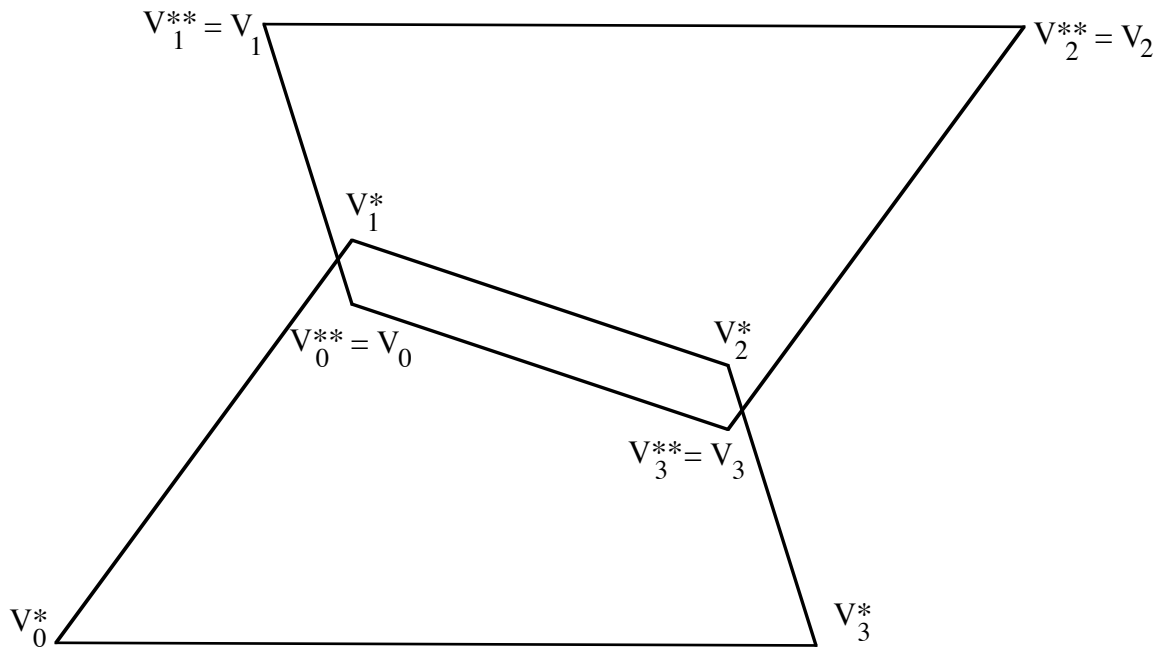

Figure N8.6. An example of a quadrangle P which is congruent to $O(P)$. The vertices have coordinates $(0.3194, 2.5694), (3.5227548996, 2.55560034), (2.2778, 0.8611), (0.6944, 1.3889)$. The maximal distance between vertices of P and the corresponding vertices of $O(P)$ is less than $1.5 \cdot 10^{-10}$. This was the limit of my patience in minimizing this distance, but there is no doubt that it can be reduced to 0 by suitably adjusting any one of the vertices of P .

3. Circumcenters.

Given an n -gon $P = [V_0, V_1, \dots, V_{n-1}]$, a new n -gon $P^* = C(P) = [V_0^*, V_1^*, \dots, V_{n-1}^*]$ is formed by the circumcenters V_j^* of the triangles $T_j = [V_{j-1}, V_j, V_{j+1}]$, for $j = 0, 1, \dots, n-1$. We shall call this transition from P to $C(P)$ the "circumcenter map". For $n = 4$ the construction is illustrated in Figure N8.7.

One interesting property of the circumcenter map was the subject of a problem in the American Mathematical Monthly in 1953 (Langr [6]). It asked to show that $C(C(P))$ is similar to P , and the determination of the ratio of similarity. (In fact, the relationship in question should have been "homothetic" instead of "similar".) No solution appeared, although the first part is easy to establish; it is illustrated in Figure N8.8. The question was repeated in a book of problems by Ogilvy [7]; it is not clear whether Ogilvy had a solution or not. The first published solution of the first part is in a book by Chou [3] devoted to proving theorems in geometry by means of computer programs. This history was reviewed in [4], and led Shephard [8] to determine the ratio of similarity λ . Shephard's result is given by the formula

$$4\lambda = -\frac{1}{\sin^2\theta_1} - \frac{1}{\sin^2\theta_2} + \frac{\sin\theta_2 \sin(\theta_1 - \theta_4)}{\sin(\theta_3 + \theta_4) \sin^2\theta_1 \sin\theta_4} + \frac{\sin\theta_1 \sin(\theta_2 - \theta_3)}{\sin(\theta_3 + \theta_4) \sin^2\theta_2 \sin\theta_3}.$$

Here the θ_j 's are the deflections at the vertices of the quadrangle P (see Figure N8.9). This expression can be transformed easily into the slightly more symmetric form

$$-8\lambda = \sum_j \frac{1}{\sin^2\theta_j} + \frac{\sin\theta_1 \sin\theta_3 + \sin\theta_2 \sin\theta_4}{\sin(\theta_1 + \theta_3) \sin(\theta_1 + \theta_4)} \cdot \sum_j (-1)^j \sin^2\theta_j.$$

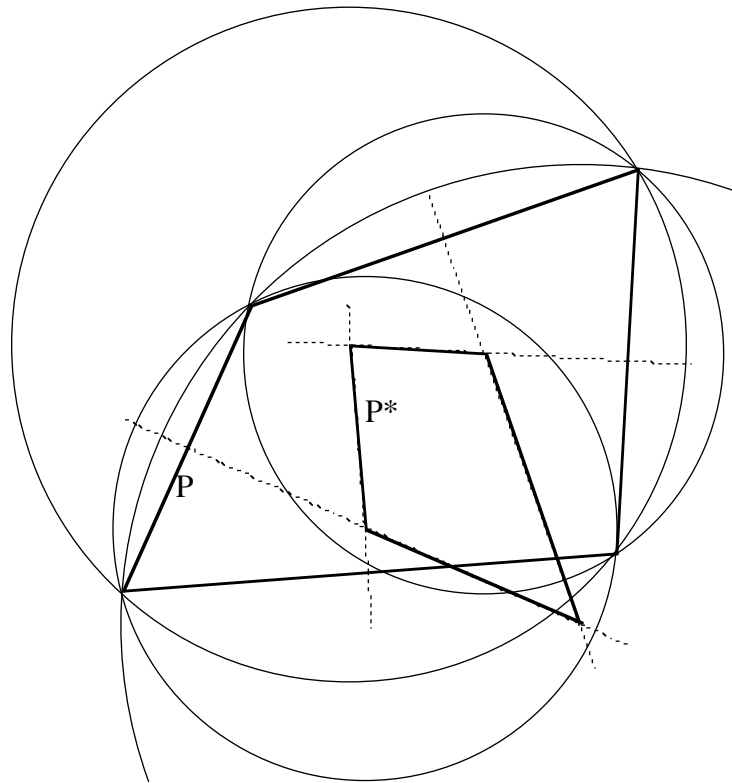

Figure N8.7. An illustration of the circumcenter map leading from a polygon P to the polygon $P^* = C(P)$.

However, I recently found that Langr's problem has been solved more than a century earlier! In a pair of papers [1], [2], Bretschneider develops a long series of trigonometric and other formulas dealing with all sorts of entities that can be associated with four points. Among the (about one hundred) formulas, some of them so long that they had to be printed sideways on the pages, is an expression for the ratio we denoted λ . To formulate Bretschneider's result, let us denote by d_{ij} the distance between vertices V_i and V_j of P . Then Bretschneider first proves that the numbers $p = d_{01} d_{23}$, $q = d_{02} d_{13}$, and $r = d_{03} d_{12}$ satisfy the triangle inequality (notice that these expressions involve the sides and the diagonals of the quadrangle). Then he considers the quantity (which corresponds to the Heron formula for the area of a triangle)

$$e = (p + q + r)(p + q - r)(p - q + r)(-p + q + r)/16$$

and defines a_j as the area of the triangle with vertices V_{j-1}, V_j, V_{j+1} . With this notation,

the ratio λ is given by $\lambda = \frac{e}{a_0 a_1 a_2 a_3}$.

It would seem worthwhile to find a reasonable proof of this relation, and also to clarify its connection to Shephard's result.

Two other aspects of the circumcenter map deserve attention. When applied to pentagons, the map does not produce $C(C(P))$ homothetic to P . However, in all

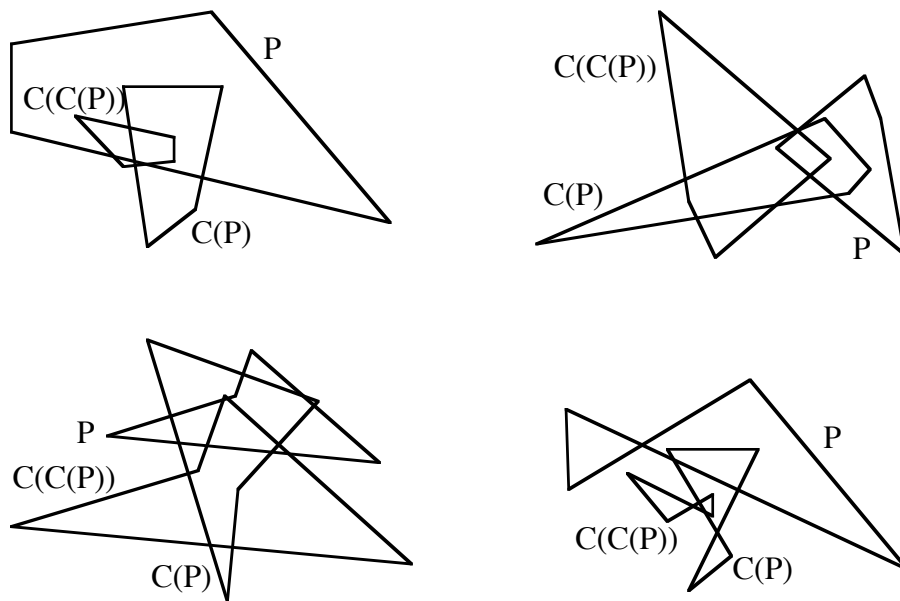

Figure N8.8. Illustrations of the homothety between a quadrangle P and its image $C(C(P))$.

experiments it turned out that $C(C(C(P)))$ is homothetic to $C(P)$ for every P , see Figure N8.10. This has so far not been established by any formal proof; also, there is no information concerning the ratio of homothety. Another open question is the characterization of those pentagons which are not images under the circumcenter map of any other pentagon.

Returning to the circumcenter map on quadrangles, it turns out that there is an analogue of the result we have seen earlier concerning orthocenters. Experimental

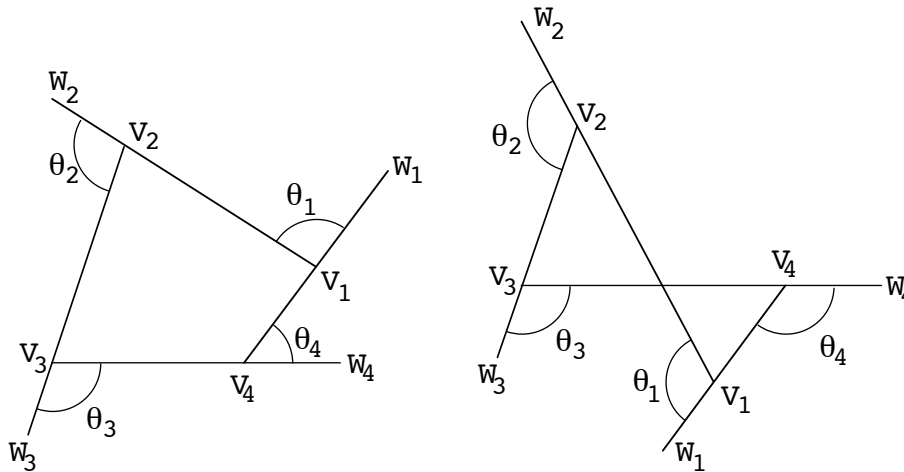

Figure N8.9. The definition of the deflections θ_j at the vertices V_j of a quadrangle. Since the angles are to be measured in the counterclockwise direction, in the illustration at right the angles θ_1 and θ_4 are negative.

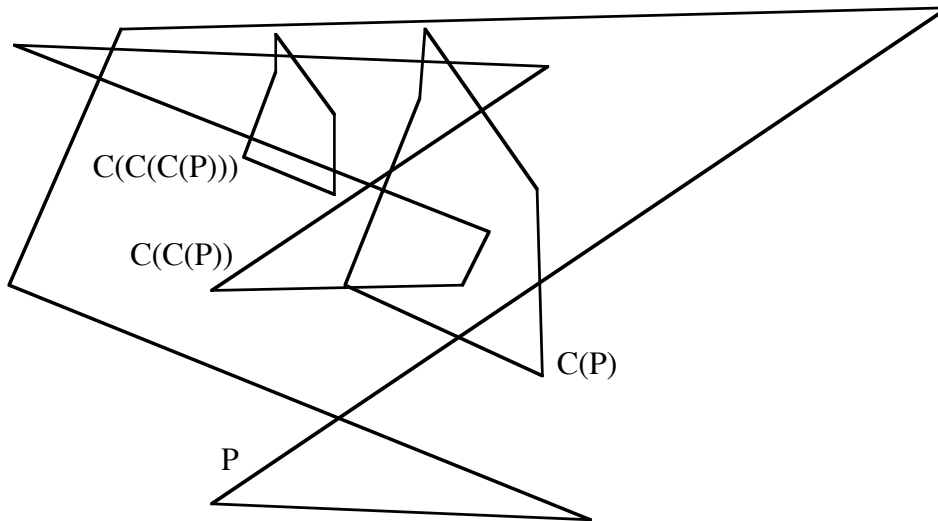

Figure N8.10. An illustration of the homothety between $C(P)$ and $C(C(C(P)))$ for a pentagon P . In general, a pentagon P is not homothetic to $C(C(P))$.

evidence shows that for every quadrangle P the image $C(P)$ under the circumcircle map is an affine image of P . Moreover, the ratio of areas of $C(P)$ and P is the same λ as given by the expressions quoted above. However, I have no information concerning the precise nature of the affinity in question.

Applied to hexagons, the circumcenter map does not produce homothetic images after any number of iterations, see [5]. Nothing seems to be known concerning any relationships between a hexagon and its images under such iterations.

Clearly, there are lots of open problems in this area.

References.

- [1] C. A. Bretschneider, Untersuchung der trigonometrischen Relationen des geradlinigen Vierecks. *Archiv der Math. und Physik* 2(1842), 225 - 261.
- [2] C. A. Bretschneider, Ueber die abgeleiteten Vierecke, welche von je vier merkwürdigen Punkten des geradlinigen Vierecks gebildet werde. *Archiv der Math. und Physik* 3(1843), 84 - 93.
- [3] S.-C. Chou, Mechanical Geometry Theorem Proving. Reidel, Boston 1988.
- [4] B. Grünbaum, Quadrangles, pentagons, and computers. *Geombinatorics* 3(1993), 4 - 9.
- [5] B. Grünbaum, Quadrangles, pentagons, and computers, revisited. *Geombinatorics* 4(1994), 11 - 16.
- [6] J. Langr, Problem E 1050. *Amer. Math. Monthly* 60(1953), 551.
- [7] C. S. Ogilvy, Tomorrow's Math. Unsolved Problems for the Amateur. Oxford Univ. Press, New York 1962. 2nd ed. 1972.
- [8] G. C. Shephard, The perpendicular bisector construction. *Geometriae Dedicata* 56(1995), 75 - 84.

References.

- [A8]N M. Adelmeyer and D. Stoffer, Iteration einer n -Ecksabbildung. *Elem. Math.* 51(1996), 1 - 16.
- [A1] K. Ahara, K. Ikeda and N. Ishimura, Linear discrete model for shortening polygons. *J. Fac. Sci. Univ. Tokyo Sect. IA, Math.*, 39(1992), pp. 365 - 377.
- [A7] R. Alexander, Metric embedding techniques applied to geometric inequalities. *The Geometry of Metric and Linear Spaces*, L. M. Kelly, ed. Lecture Notes in Math. Vol. 490, Springer, New York 1975, pp. 57 - 65.
- [A2] J. M. Ali, Another proof of Napoleon's triangle theorem. *Menemui Mat.* 10(1988), pp. 34 - 38.
- [A3] R. E. Allardice, The equilateral and the equiangular polygon. *Proc. Edinburgh Math. Soc.* 5(1887), 28 - 38 + plates.
- [A4] R. E. Allardice, Geometrical notes. *Proc. Edinburgh Math. Soc.* 5(1887), 78 - 83 + plates.
- [A5] R. E. Allardice, On the inscription of a triangle of given shape in a given triangle. *Proc. Edinburgh Math. Soc.* 6(1888), 42 - 47 + plates.
- [A6] R. E. Allardice, On a property of odd and even polygons. *Proc. Edinburgh Math. Soc.* 8(1890), 22 - 26 + plates.
- [A9]N A. R. Amir-Moez and J. D. Hamilton, A generalized parallelogram law. *Math. Magazine* 49(1976), 88 - 89.
- [B1] F. Bachmann, n -gons, *Educational Studies in Mathematics* 3(1971), pp. 288-309.
- [B17] F. Bachmann and J. Boczeck, Points, Vectors, and Reflections. Chapter 2 of Vol. 2, of *Fundamentals of Mathematics*, H. Behnke *et al.*, eds. Translated by S. H. Gould. MIT Press, Cambridge, MA 1974.
- [B2] F. Bachmann and E. Schmidt, n -Ecke. Bibliographisches Institut, Mannheim, 1970; English translation: n -gons, by C. W. L. Garner, Univ. of Toronto Press, 1975.
- [B12] L. Bankoff, P. Erdős and M. Klamkin, The asymmetric propeller. *Math. Mag.* 46(1973), 270 - 272.
- [B3] A. Barlotti, Intorno ad una generalizzazione di un noto teorema relativo al triangolo. *Boll. Un. Matem. Ital.* (3) 7(1952), pp. 182 - 185.
- [B4] A. Barlotti, Una proprietà degli n -agoni che si ottengono trasformando in una affinità un n -agono regolare. *Boll. Un. Matem. Ital.* (3) 10(1955), pp. 96 - 98.

- [B5] G. Bellavitis, *Exposition de la méthode des équipollences*. Translated from the Italian original (published in 1854) by C.-A. Laisant. Gauthier-Villars, Paris 1874.
- [B6] E. R. Berlekamp, E. N. Gilbert and F. W. Sinden, A polygon problem. *Amer. Math. Monthly* 72(1965), pp. 233-241; reprinted in *Selected Papers on Algebra*, Mathematical Association of America, Washington, D.C., 1977.
- [B7] U. Bini, Discendenza napoleonica. *Archimede* 5(1953), pp. 103 - 108 and 158 - 164.
- [B16] K. W. Blain, Problem No. 143. *Nat. Math. Magazine* 11(1937), p. 340. Solution by J. Rosenbaum, *ibid.* 12(1937/38), 46 - 47.
- [B15] R. H. Blomfield, A property of the triangle. *Math. Gazette* 21 (1937), 158 - 159.
- [B8] C. Bonferroni, Un teorema sul triangolo e il teorema di Napoleone. *Boll. Un. Matem. Ital.* (3) 5(1950), pp. 85 - 89.
- [B9] L. Bos and B. Sands, Problem 1679. *Crux Mathematicorum* 17(1991), p. 238; solution, *ibid.* 18(1992), pp. 248 - 250.
- [B13] M. Bourdeau and S. Dubuc, L'itération de Fejes Tóth sur un polygone. *J. Geom.* 6(1975), pp. 65 - 75.
- [B18]N G. Boutte, The Napoleon configuration. *Forum Geometricorum* 2(2002), 39 - 46.
- [B14] G. Bruckner, Über n-Ecke. *Studia Sci. Math. Hungar.* 7(1972), pp. 429 - 435.
- [B10] L. Brusotti, Interpretazioni di un teorema di Geometria elementare. *Boll. Un. Matem. Ital.* (3) 1(1946), pp. 43 - 47.
- [B11] B. Budinský, Zum Peterschen Satz. *Casopis Pest. Mat.* 97(1972), pp. 72 - 74.
- [C1] J. H. Cadwell, A property of linear cyclic transformations. *Math. Gazette* 37(1953), pp. 85 - 89.
- [C2] J. H. Cadwell, *Topics in Recreational Mathematics*. Cambridge, 1966.
- [C3] V. G. Cavallaro, Sur les segments toricelliens. *Mathesis* 52(1938), pp. 290 - 293.
- [C4] V. G. Cavallaro, Per la storia dei teoremi attribuiti a Napoleone Buonaparte e a Frank Morley. *Archimede* 7-8(1949), pp. 286 - 287.
- [C5] G.-Z. Chang, A proof of a theorem of Douglas and Neumann by circulant matrices. *Houston J. Math.* 8(1982), pp. 15 - 18.
- [C6] G.-Z. Chang and P. J. Davis, A circulant formulation of the Napoleon–Douglas–Neumann theorem. *Linear Algebra Appl.* 54(1983), pp. 87 - 95.

- [C7] R. J. Clarke, Sequences of polygons. *Math. Mag.* 52(1979), pp. 102 - 105.
- [C8] É. Collignon, Sur certaines séries de triangles et de quadrilatères. *Assoc. Franç. Avance. Sci.* 20(1891), pp. 38 - 66.
- [C9] H. S. M. Coxeter, Affinely regular polygons. *Abhand. Math. Seminar Univ. Hamburg* 34(1969), pp. 38 - 58.
- [C10] H. S. M. Coxeter, *Regular Complex Polytopes*. Cambridge Univ. Press 1975. Second ed. 1991.
- [C11] H. S. M. Coxeter, Affine regularity. *C. R. Math. Reports Acad. Sci. Canada* 13(1991), pp. 181 - 186.
- [C13] H. S. M. Coxeter, Affine regularity. *Abh. Math. Sem. Univ. Hamburg* 62(1992), 249 - 253.
- [C12] H. S. M. Coxeter and S. L. Greitzer, *Geometry Revisited*. MAA, Washington D.C., 1967.
- [C14] K. W. Crain, Two families of parallelograms. *Nat. Math. Magazine* 11(1937), 304 - 309.
- [D1] G. Darboux, Sur un problème de géométrie élémentaire. *Bull. Sci. Math.* (2)2(1878), pp. 298 - 304.
- [D2] P. J. Davis, Cyclic transformations of polygons and the generalized inverse. *Canad. J. Math.* 29(1977), pp. 756 - 770.
- [D3] P. J. Davis, *Circulant Matrices*. Wiley-Interscience, New York 1979.
- [D4] P. J. Davis, Cyclic transformations of n-gons and related quadratic forms. *Linear Algebra Appl.* 25(1979), 57 - 75.
- [D9] P. J. Davis, The rise, fall, and possible transfiguration of triangle geometry: a mini-history. *Amer. Math. Monthly* 102(1995), 204 - 214.
- [D14]N N. Dergiades and F. van Lamoen, Rectangles attached to sides of a quadrangle. *Forum Geometricorum* 3(2003), 145 - 159.
- [D10]N S. Desmet and R Rouseau, The area of the hexagon of centroids. *Math. Gazette*70(1986), 134 - 135.
- [D13]N N. Dimitrov, On some results about Napoleon's configuration. Preprint 2009.
- [D8] K. Doliwka and M. Lassak, On relatively short and long sides of convex pentagons. *Geom. Dedicata* 56(1995), 221 - 224.
- [D5] J. Douglas, Geometry of polygons in the complex plane. *J. Math. Phys.* 19(1940), 93-130.

- [D6] J. Douglas, On linear polygon transformations. *Bull. Amer. Math. Soc.* 46(1940), 551 - 560.
- [D7] J. Douglas, A theorem on skew pentagons. *Scripta Math.* 25(1960), pp. 5-9.
- [D11]N A. Dresden, On the iteration of linear homogeneous transformations. *Bull. Amer. Math. Soc.* 48(1942), 577 - 579.
- [D12]N A. Dress, Repetition und Metamorphose - zum Symmetriebegriff in der Mathematik. *Symmetry of Discrete Mathematical Structures and Their Symmetry Groups*. K. H. Hofmann and R. Wille, eds., Heldermann, Berlin 1990. Pp. 89 - 117.
- [F1] A. Favaro, Justus Bellavitis. *Zeitschrift für Math. und Phys.* 26(1881), 152 - 169.
- [F8] G. Fejes Tóth, Processes of iteration leading to regular polygons. [In Hungarian] *Mat. Lapok* 23(1972), pp. 135 - 141.
- [F9] L. Fejes Tóth, Processes of iteration concerning polygons. [In Hungarian] *Mat. Lapok* 20(1969), pp. 15 - 23.
- [F10] L. Fejes Tóth, Research Problem #4. *Period. Math. Hungar.* 4(1973), p. 81.
- [F2] L. Fejes Tóth, Sequences of polyhedra. *Amer. Math. Monthly* 88(1981), 145 - 146.
- [F14]N H. E. Fettis, The Fermat and Hessian points of a triangle. *Amer. Math. Monthly* 53(1946), 74 - 78.
- [F3] R. L. Finney, Dynamic proofs of Euclidean theorems. *Math. Mag.* 43(1970), pp. 177 - 185.
- [F4] P. Finsler and H. Hadwiger, Einige Relationen im Dreieck. *Comment. Math. Helv.* 10(1937), pp. 316 - 326.
- [F11] W. Fischer, Ein geometrischer Satz. *Arch. Math. Phys.* 40(1863), 460 - 462.
- [F12] J. Fischer, *Napoleon und die Wissenschaften*. Steiner, Wiesbaden 1988.
- [F5] J. C. Fisher, D. Ruoff and J. Shilleto, Polygons and polynomials. In: *The Geometric Vein: the Coxeter Festschrift*, C. Davis, B. Grünbaum, F. A. Scherk, eds., pp. 165-176. Springer, New York, 1981.
- [F6] J. C. Fisher, D. Ruoff and J. Shilleto, Perpendicular polygons. *Amer. Math. Monthly* 92(1985), 23 - 37.
- [F7] É. Françoise, Application du calcul des équipollences à la résolution d'un problème de géométrie élémentaire. *Nouv. Ann. Math.* 9(1870), pp. 66 - 73.
- [F13] R. Fritsch, Historische Anmerkungen zu "Affin-reguläre n-Ecke und ihre Komponenten". *Math. naturwiss. Unterricht* 39(1986), 502.

- [F15]N J. Fukuta, Equilateral triangles in a hexagon. Problem 1455, *Math. Magazine* 68(1995), 309 – 310.
- [F16]N J. Fukuta, Problem 1493. *Math. Magazine* 69(1996), 67.
- [G8]N D. Gale, Anatomy and evolution of a theorem on triangles. *Math. Intelligencer* 18(1996), 32 – 34.
- [G7] J. Garfunkel, A Napoleon triangle revisited. *Pi Mu Epsilon J.* 9(1991), 234 - 241.
- [G9]N J. Garfunkel, Problem *742. *Pi Mu Epsilon J.* 9(1990),331 – 333.
- [G1] J. Garfunkel and S. Stahl, The triangle reinvestigated. *Amer. Math. Monthly* 72(1965), pp. 12 - 20.
- [G2] G. Geise, Über Aufsatzdreiecke. *Elem. Math.* 16(1961), pp. 73 - 78.
- [G3] L. Gerber, The parallelogram inequality. *Pub. Fac. Electrotechnique Univ. Belgrade*, Ser. Math. Phys., no. 461 - 497(1974), pp. 107 - 109.
- [G4] L. Gerber, Napoleon's theorem and the parallelogram inequality for affine regular polygons. *Amer. Math. Monthly* 87(1980), pp. 644-648.
- [G5] J. W. L. Glaisher, [Generalization of the foregoing theorem]. *Messenger of Math.* (2)3(1874), pp. 57 - 58..
- [G6] B. Grünbaum, Regular polyhedra -- old and new. *Aequationes Math.* 16(1977), 1 - 20.
- [H1] E. Herrmann, Aufgabe 379. *Elem. Math.* 15(1960), p. 71.
- [H4] J. E. Hofmann, Zur elementaren Dreiecksgeometrie in der komplexen Ebene. *Enseign. Math.* (2) 4(1958), 178 - 211.
- [H2] J. Holmes, Theorem in trigonometry. *Messenger of Math.* (2)3(1874), pp. 56 - 57.
- [H3] R. E. Huston, Solution to Problem 3547. *Amer. Math. Monthly* 40(1933), pp. 184 - 185.
- [J1] M. Jeger, Komplexe Zahlen in der Elementargeometrie. *Elem. Math.* 37(1982), pp. 136 - 147.
- [J2]N S. Jones, Two iteration examples. *Math. Gazette* 74(1990), 58 – 62.
- [K8]° F. Kárteszi, A pair of affinely regular pentagons generated from a convex pentagon. [In Hungarian] *Mat. Lapok* 20(1969), pp. 7 - 13.
- [K1] E. Kasner, The group generated by central symmetries, with applications to polygons. *Amer. Math. Monthly* 10(1903), 57 - 63.

- [K2] E. Kasner, Centroidal polygons and groups. *Scripta Math.* 2(1934), pp. 131 - 138.
- [K3] E. Kasner and G. Comenetz, Groups of multipoint transformations with application to polygons. *Scripta Math.* 4(1936), pp. 37 - 49.
- [K4] E. Kasner, E. Jonas, K. Way and G. Comenetz, Centroidal polygons and groups. *Scripta Math.* 2(1934), pp. 131 - 138.
- [K5] P. J. Kelly, Von Aubel's quadrilateral theorem. *Math. Magazine* 39(1966), 35 - 37.
- [K6] P. J. Kelly and D. Merriell, Concentric polygons. *Amer. Math. Monthly* 71(1964), 37 - 41.
- [K10] D. Kirby, Concurrences for a triangle. *Amer. Math. Monthly* 87(1980), 45 - 47.
- [K7] E. Kitchen, Problem 10415. *Amer. Math. Monthly* 101(1994), pp. 912 - 913.
- [K9]^o G. Korchmáros, A process of iteration leading to affinely regular polygons. [In Hungarian] *Mat. Lapok* 20(1969), pp. 405 - 411.
- [K11] J. Kratz, Vom regulären Fünfeck zum Satz von Napoleon-Barlotti. *Didaktik der Math.* 20(1992), 261 - 270.
- [L1] C. Ladd, Solution to Question 3989. *Educational Times Reprints* 19(1873), p. 55.
- [L2] C.-A. Laisant, Sur quelques propriétés des polygones. *Comptes rendus Assoc. Franç. Avanc. Sci.* 6(1877), 142 - 154.
- [L3] C.-A. Laisant, *Théorie et applications des équipollences*. Gauthier-Villars, Paris 1887.
- [L4] P. Lancaster, *Theory of Matrices*. Academic Press, New York and London, 1969.
- [L8]N P. Lancaster and M. Tismenetsky, *Theory of Matrices with Applications*> Academic Press, Orlando 1985.
- [L5] J. Langr, O jisté úloze v trojúhelníku. *Casopis Pest. Mat. Fys.* 34(1905), pp. 65 - 72.
- [L6] J. A. Lester, A generalization of Napoleon's theorem to n-gons. *C. R. Math. Rep. Acad. Sci. Canada* 16(1994), pp. 253 - 257.
- [L7] G. Lükö, Certain sequences of inscribed polygons. *Period. Math. Hungar.* 3(1973), pp. 255 - 260.
- [M7] J. S. Mackay, Properties of the figure consisting of a triangle, and the squares described on its sides. *Proc. Edingurgh Math. Soc.* 6(1888), 2 - 12 + plate.

- [M5] J. S. Mackay, Isogonic centres of a triangle. *Proc. Edingurgh Math. Soc.* 15(1897), 100 - 118.
- [M8] K. Malecek, Geometrischer Beweis der diskreten Ungleichung von W. Wirtinger. *Mathg. Bohemica* 120(1995), 83 - 89.
- [M6] H. Martini, Recent results in elementary geometry. III: The theorem of Napoleon and related topics. *Math. Semesterberichte* 43(1996), 47 - 64.
- [M9]N M. N. Maryukov, Construction of some computational algorithms on finite sets of points in the plane. *Russian Math. Surveys* 50(1885),442 - 443.
- [M1] J. G. Mauldon, Similar triangles. *Math. Mag.* 39(1966), pp. 166 - 174.
- [M2] D. Merriell, Further remarks on concentric polygons. *Amer. Math. Monthly* 2(1965), pp. 960-965.
- [M3] P. Monsky, Problem 6639. *Amer. Math. Monthly* 97(1990), pp. 622; solution by J. H. Lindsey II, *ibid.* 101(1994), 683 - 685.
- [M4] C. Müsebeck, Zu "Über einen Lehrsatz vom Sechseck". *Math. Naturw. Blätter* 2(1905), p. 125.
- [M10]N C. H. Nagel, Ueber die Bestimmung der Vielecke durch die Halbirungspunkte ihrer Seiten. *Archiv der Math. und Physik* 53(1871), 378 - 381.
- [N1] H. Naumann, Zwei weitere Beweise zu einer Verallgemeinerung des Satzes von Napoleon. *Bayer. Akad. Wiss., Math.-Naturwiss. Kl., Sitz.-Ber.* 1990(1991), pp. 1 - 3.
- [N2] R. D. Nelson, Napoleon revisited. *Math. Gaz.* 58(1974), pp. 108 - 116.
- [N3] J. Neuberg, Quelques propriétés du triangle. *Nouv. Corresp. Math.* 4(1878), pp. 142 - 146.
- [N4] J. Neuberg, Notes de géométrie. *Assoc. Franç. Avance. Sci.* 22(1893), pp. 26 - 45.
- [N5] J. Neuberg. Sur quelques quadrilatères spéciaux. *Mathesis* 4(1894), pp. 268 - 271.
- [N6] B. H. Neumann, Some remarks on polygons. *J. London Math. Soc. (first series)*, 16(1941), pp. 230-245. Addenda: H. F. Baker, A remark on polygons. *ibid.* 17(1942), pp. 162-164, and B. H. Neumann, A remark on polygons. *ibid.*, 17(1942), pp. 165-166.
- [N7] B. H. Neumann, Plane polygons revisited. In: *Essays in Statistical Science: Papers in Honour of P. A. P. Moran*, J. Gani and E. J. Hannan, eds. *J. of Appl. Prob., Special volume* 19A(1982), pp. 113 - 122.
- [N8] J. Novotná, Variations of discrete analogues of Wirtinger's inequality. *Casopis pro Pest. Mat.* 105(1980), 278 - 285.

- [N9] J. Novotná, Discrete analogues of Wirtinger's inequality for a two-dimensional array. *Casopis pro Pest. Mat.* 105(1980), 354 - 362.
- [N10] J. Novotná, A sharpening of discrete analogues of Wirtinger's inequality. *Casopis pro Pest. Mat.* 108(1983), 70 - 77.
- [O1] H. Okumura, Regular n -gons on the sides of a triangle. *Pi Mu Epsilon J.* 9(1991), pp. 297 - 299.
- [O2]N R. Oldenburger, Infinite powers of matrices and characteristic roots. *Duke Math. J.* 6(1940), 357 - 361.
- [P5]N P. Pech, Inequality between sides and diagonals of a space n -gon and its integral analog. *Casopis pro péstování matematiky* 115(1990), 343 - 350.
- [P1] J. W. Peters, Solution to Problem 3367. *Amer. Math. Monthly* 37(1930), pp. 97 - 99.
- [P2] K. Petr, O jedné větě pro mnohoúhelníky rovinné. *Casopis pro pestovani matematiky i fyziky*, 34(1905), pp. 166-172.
- [P3] K. Petr, Ein Satz über Vielecke. *Archiv. Math. Phys.* (3), 13(1908), pp. 29-31.
- [P4] G. Pickert, Bemerkungen zum Satz von Napoleon. *Math. Semesterber.* 39(1992), 37 - 41.
- [P7]N G. Pickert, Drehungen und komplexe Zahlen beim Beweis des Satzes von Napoleon-Barlotti und seiner Umkehrung. *Didakt. Math.* 23(1995), 29 - 36.
- [P6]N J. Pottage, *Geometrical Investigations*. Addison-Wesley, Reading, MN, 1983.
- [R13]N S. Rabinowitz, Problem E2122. *Amer. Math. Monthly* 76(1969), 833.
- [R5] H. Reichardt, Bestätigung einer Vermutung von Fejes Tóth. *Rev. Roumaine Math. Pures Appl.* 15(1970), pp. 1513 - 1518.
- [R6] J. F. Rigby, Napoleon revisited. *J. Geom.* 33(1988), pp. 129 - 146.
- [R7] J. F. Rigby, Napoleon, Escher and tessellations. *Math. Mag.* 64(1991), pp. 242 - 246.
- [R8] J. F. Rigby, Napoleon, Escher and tessellations. *Struct. Topology* 17(1991), pp. 17 - 23.
- [R14]N A. Robert, Fourier series of polygons. *Amer. Math. Monthly* 101(1994), 420 - 428.
- [R1] M. Rosenman, Problem 3547. *Amer. Math. Monthly* 39(1932), p. 239.
- [R12] H. Rothe, Systeme geometrischer Analysis. Erster Teil. *Encyklopädie der Mathematischen Wissenschaften*, Band 3, Geometrie, pp. 1277 - 1423. Teubner, Leipzig, 1920.

- [R9] M. Ruda, Fejes Tóth László egy sejtéséről. [In Hungarian] *Magyar Tud. Akad. Mat. Fiz. Oszt. Közl.* 19(1969), pp. 3 - 4.
- [R10] M. Ruda, On a conjecture of L. Fejes Tóth. [In Hungarian] *Magyar Tud. Akad. Mat. Fiz. Oszt. Közl.* 19(1970), pp. 375 - 381.
- [R11] M. Ruda, A theorem concerning bisecting-polygons. [In Hungarian] *Magyar Tud. Akad. Mat. Fiz. Oszt. Közl.* 22(1973), pp. 201 - 213.
- [R2] D. Ruoff, Eine kleine n -Ecks-Lehre. *Elem. Math.* 43(1988), 129 - 144.
- [R3] D. Ruoff and J. Shilleto, Recursive polygons. *Bolletino Un. Mat. Ital.* (5) 15-B(1978), pp. 968-981.
- [R4] W. Rutherford, Problem 1439. *The Ladies' Diary* 122(1825). Solutions by T. Burn, J. Walker, Mr. Mason, et al. 123(1826).
- [S16] H. Schaal, Zur Verwandtschaft der Zwillingspunkte beim Dreieck. *Beiträge zur Algebra und Geometrie* 34(1993), 177 - 189.
- [S1] E. Schmidt, Affin-reguläre n -Ecke und ihre regulären Komponenten. *Math. Naturwiss. Unterricht* 39(1986), 193 - 198.
- [S15] F. Schmidt, 200 Jahre französische Revolution; Problem und Satz von Napoleon mit Variationen. *Didaktik der Mathematik* 18(1990), 15 - 29.
- [S2] I. J. Schoenberg, The finite Fourier series and elementary geometry. *Amer. Math. Monthly* 57(1950), pp. 390 - 404.
- [S18]N I. J. Schoenberg, Remarks on two geometric conjectures of L. Fejes Tóth. *An. Sti. Univ. "Al. I. Cuza" Iasi Sect. 1A Mat. (N.S.)* 21(1975), 9-13. (MR53#6420)
- [S3] I. J. Schoenberg, The harmonic analysis of skew polygons as a source of outdoor sculptures. In: *The Geometric Vein: the Coxeter Festschrift*, C. Davis, B. Grünbaum, F. A. Scherk, eds., pp. 165-176. Springer, New York, 1981.
- [S4] I. J. Schoenberg, *Mathematical Time Exposures*. Math. Assoc. of America, Washington, DC, 1982.
- [S5] I. J. Schoenberg, Problem E3198. *Amer. Math. Monthly* 94(1987), p. 301; solution by J. van der Craats, *ibid.* 95(1988), p. 958.
- [S6] H. Schumann, The desing of microworlds in geometry based on a two-dimensional graphics system devised for secondary education. *Int. J. Math. Edu. Sci. Technol.* 24(1993), 231 - 250.
- [S7] W. Schuster, Polygonfolgen und Napoleonsätze. *Mathem. Semesterberichte* 41(1994), 23 - 42.
- [S23]N W. Schuster, Ein kurzer Beweis zum Satz von Napoleon-Barlotti. *Didakt. Math.* 23(1995), 165 - 167.

- [S20]N W. Schuster, Quadratische Identitäten bei Polygonen. *Aequat. Math.* 54(1997), 117 - 143.
- [S21]N W. Schuster, Die Transformation einer geschlossenen Kurve in eine Ellipse. *Elem. Math.* 53(1998), 61 - 72.
- [S22]N W. Schuster, Regularisierung van Polygonen. *Math. Semesterberichte* 45(1998), 77 - 94.
- [S8] K. Schütte, Eine Verallgemeinerung des Satzes von Napoleon. *Math. Semesterberichte* 34(1987), pp. 256 - 268.
- [S9] K. Schütte, Neue Fassung einer Verallgemeinerung des Satzes von Napoleon. *Elem. Math.* 44(1989), pp. 133 - 138.
- [S10] C. J. Scriba, Wie kommt "Napoleons Satz" zu seinem Namen? *Hist. Math.* 8(1980), pp. 458-459.
- [S11] D. B. Shapiro, A periodicity problem in plane geometry. *Amer. Math. Monthly* 91(1984), pp. 97-108.
- [S24]N G. C. Shephard, Sequences of smoothed polygons. *Discrete Geometry: In Honor of W. Kuperberg's 60th Birthday*. A. Bezdek, rd. Dekker, New York 2003. Pp. 407 - 430.
- [S12] J. R. Shilleto and D. Ruoff, Decompositions of n-gons into n-gons. *Geom. Dedicata* 4(1975), pp. 271 - 278.
- [S17] O. Shisha, On the discrete version of Wirtinger's inequality. *Amer. Math. Monthly* 80(1973), 755 - 760.
- [S13] H. Stachel, Zu K. Schüttes Verallgemeinerung des Satzes von Napoleon. *Elem. Math.* 46(1991), pp. 133 - 138.
- [S19]N E. Strekalovskiy, Folgen von Höhenfußpunktdreiecken un ihre Grenzpunkte. *Elem. Math.* 64(2009), 53 - 70.
- [S14]° A. Szép, Linear iterations of polygons. [In Hungarian]. *Magyar Tud. Akad. Mat. Fiz. Oszt. Közl.* 21(1970), pp. 363 - 368.
- [T1] V. Thébault, Quadrilatère bordé de carrés. *Assoc. Franç. Avance. Sci.* 56(1932), pp. 78 - 82.
- [T2] V. Thébault, Quadrangle bordé de triangles isoscèles semblables. *Ann. Soc. Sci. Bruxelles* 60(1940), pp. 64 - 70.
- [T3] V. Thébault, Solution to Problem 169. *National Math. Mag.* 12(1937/38), pp. 192 - 194.
- [T4] V. Thébault, Octogone bordé de carrés. *Mathesis* 54(1940), 114 - 117.

- [T5] V. Thébault, Polygone de $2n$ côtés bordé de triangles isoscèles semblables. *Mathesis* 54(1940), pp. 161 - 166.
- [T7]N S. Y. Trimble, The limiting case of triangles formed by angle bisectors. *Math. Gazette* 80(1996), 554 - 556.
- [T6] G. Turner, *Elementi di geometria*. Vol. 1. Palermo 1843.
- [V1] M. H. van Aubel, Note concernant les centres des carrés construits sur les cotés d'un polygone quelconque. *Nouv. Corresp. Math.* 4 (1878), pp. 40-44.
- [V2] M. H. van Aubel, Question 56. *Mathesis* 1(1881), 167.
- [V3] J. van de Craats and J. Simonis, Affinely regular polygons. *Nieuw Arch. Wisk.* 4(1986), pp. 225-240.
- [V6]N F. van Lamoen, Napoleon triangles and Kiepert perspectors. *Forum Geometricorum* 3(2003), 65 - 71,
- [V4] G. Varoli, Di un teorema sul triangolo. *Boll. Un. Matem. Ital.* (3) 5(1950), pp 360 - 363.
- [V5] M. D. de Villiers, A generalisation of the Fermat-Torricelli point. *Math. Gazette* 79(1995), 374 - 378.
- [W1] John E. Wetzel, Converses of Napoleon's Theorem. *Amer. Math. Monthly* 89(1992), pp. 339-351.
- [W2] E. T. Wong, Polygons, circulant matrices, and Moore-Penrose inverses. *Amer. Math. Monthly* 88(1981), 509 - 515.
- [W4]N Y.-C. Wong, Some properties of the triangle. *Amer. Math. Monthly* 48(1941), 530 - 535.
- [W3] Y.-C. Wong, Some extensions of the Douglas-Neumann theorem for concentric polygons. *Amer. Math. Monthly* 75(1968), 470 - 482.
- [Y1] I. M. Yaglom, *Geometric transformations*. Random House, New York 1962.
- [Z1] M. Zacharias, Über einen Lehrsatz vom Sechseck. *Math. Naturw. Blätter* 2(1905), p. 86.
- [Z2]N B. Ziv, Napoleon-like configurations and sequences of triangles. *Forum Geometricorum* 2(2002), 115 - 128.