

Salvaged Witness,  
KeyArena Meets Nowness

Xiaoxi Jiao  
Kejia Zhang

A thesis  
submitted in partial fulfillment of the requirements for the degree of  
Master of Architecture

University of Washington  
2017

Committee:  
Robert Hutchison  
David Miller  
Cory Mattheis

Program Authorized to Offer Degree:  
Architecture

© Copyright 2017

Xiaoxi Jiao

Kejia Zhang

University of Washington

Abstract

Salvaged Witness,  
KeyArena Meets Nowness

Xiaoxi Jiao

Kejia Zhang

Chair of the Supervisory Committee:

Robert Hutchison

Affiliate Assistant Professor, Department of Architecture

KeyArena is a witness of history and underused masterpiece. It roots deeply within the history of Seattle, but its obsolescence fails to sustain its desire to be actively used. KeyArena is a local landmark but fails to keep up with the pace of nowness. Its humble form, stunning structure and center for civic activity need to be salvaged. This unconventional preservation project is an homage to diverse layers of time. Existing and newly inserted conditions confront and interact with each other, offering an ensemble and coexistence of fragments that will not be depicted by a single image, or allow any part to overtake the others. New, old, horizontal, vertical, wide, narrow, light, dark, over, under, open, enclosed... All these oppositions establish the range of complexity in architecture that define the new dimension of salvaged KeyArena, which transforms the witness to the heart of nowness.

This document is best viewed as a two page spread  
with this page on the left

An architectural line drawing of a city block, viewed from an elevated perspective. The drawing uses black lines on a background of fine, multi-colored dots (yellow, green, blue, red). A prominent, thick, red ribbon-like shape winds through the scene, crossing over a large, white, three-dimensional cube that sits on a platform. The ribbon starts from the bottom left, loops around the cube, and extends towards the top right. The city buildings are rendered in a simplified, geometric style.

# Salvaged Witness, KeyArena Meets Nowness

*Student: Kejia Zhang, Xiaoxi Jiao*

*Committee: Robert Hutchison(Chair), David Miller, Cory Mattheis*

# INTRO

Seattle is a city known for its eye-opening panoramic views. Glancing through the skyline of downtown, people's eyes pause at the iconic Space Needle. Although not as glamorous, people can not miss another important existence, a tent-like structure who steadily sits low and wide, counter-balancing the sharpness of the Space Needle. On top of the tent-like roof, there is a giant red bright sign that says KeyArena. But if you ask Seattleites about it, they might not be very familiar with it other than having been there for concerts or games once or twice.

KeyArena is a part of people's daily panoramic view, but not their daily lives.





# CONTENTS

<b>Intro</b>	<b>2</b>
<b>Chapter 1: Witness</b>	<b>6</b>
1962: Washington State Coliseum (Coliseum Century 21)	8
1964: Seattle Center Coliseum	10
1993-1995: Remodeling as KeyArena	18
2008: The Sonics' Leave	26
<b>Chapter 2: Nowness</b>	<b>30</b>
Urban Center: Densification of Neighborhoods	32
Seattle Center Station: Sound Transit 3 Link Light Rail Ballard Line	34
Elementary School: Missing Piece from 1959	36
Public Plaza: Main Axis and Market Plaza	38
<b>Chapter 3: Pre-Proposal</b>	<b>40</b>
Current Condition	42
Programs	46
Precedent Study	48
Inspiration	58

<b>62</b>	<b>Chapter 4: Proposal</b>
66	Thesis Statement: Salvaged Witness, KeyArena Meets Nowness
68	Thesis Goal: Opening the Gift Box
70	Diagram: Cake Metaphor, phase 1-5
82	24/7: Collages of Building Functions
98	Rendering, Drawing, Sustainability
<b>130</b>	<b>Chapter 5: Conclusion</b>
<b>134</b>	<b>Appendix</b>
140	Reference
142	Image Credits
144	Acknowledgement

# Chapter 1:

## Witness

“One could say architecture is the last profession that has a memory. Architecture stands with one leg in a world that is 3,000 years old and another leg in the 21st century.”<sup>1</sup> This almost ballet-like stretch makes this profession surprisingly deep and profound. We value the historic building, the KeyArena, as witness, which is the memory, the history and serves as a link between the past and present.



# 1962

## WASHINGTON STATE COLISEUM

The building now known as KeyArena was originally built for the 1962 Seattle World's Fair the World of Century 21, as the Washington State Coliseum, and was home to the "World of Tomorrow" exhibit. "The story of Century 21 is one of science and technology at work for mankind. To translate this firm hope of century ahead into reality."<sup>2</sup>

The Washington State Coliseum was designed by Paul Thiry, Seattle's most distinguished post-war architect, the lead architect for the 1962 World's Fair. He sculpted the Coliseum as a 400-ft-square horizontal counterpoint to the 600-ft-tall Space Needle.

The Washington State Coliseum was located on the west side of the 1962 Seattle World's Fair site called Seattle Center. The site was selected for its central location and easy accessibility as the City's civic gathering place. The Coliseum was constructed over 4 adjoining city blocks. Most existing buildings on the 4 blocks were single family houses, with an exception of an elementary school, the Warren Avenue school at the northeast corner.

The Coliseum is one of the buildings of 1960s structural inventions. "The Coliseum Century 21, being built by the State of Washington, is believe to be the first clear span, tri-level exposition pavilion. Its height is equal to an 11-story conventional building."<sup>3</sup>

1962 Seattle World's Fair was located only one mile from the downtown area. It functioned as Seattle's civic and cultural complex after the exposition closed.



The 1912 Baist Real Estate Map: The left of the green block is where the Warren Ave School was. The Mercer play field became the international fountain. The Coliseum constructed over 4 adjoining city blocks (red boundary).

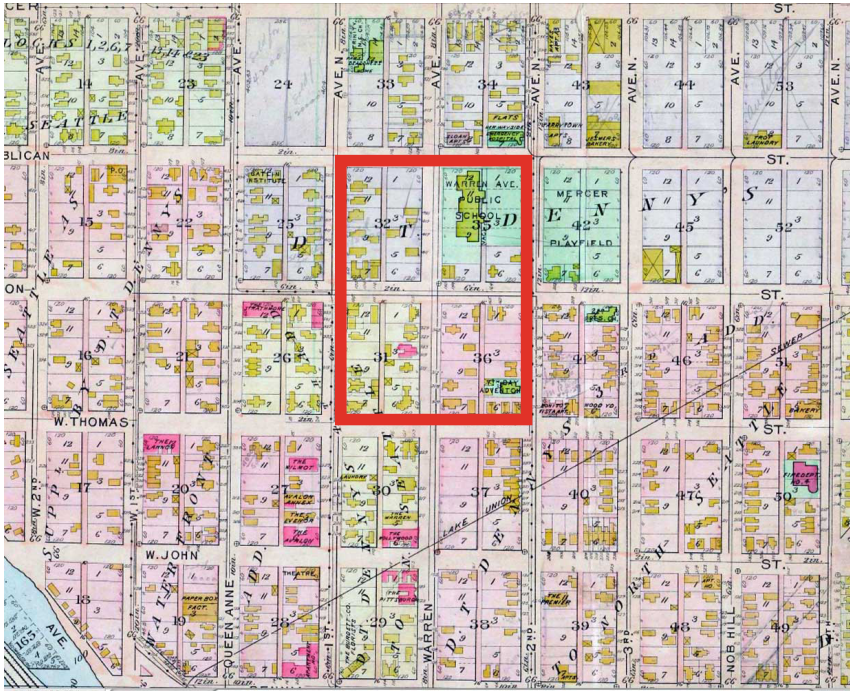

Four steel space trusses rise from massive, three-legged concrete abutments to support a pretensioned concrete peripheral rim. The catenary hyperbolic paraboloid roof suspended by a network of cables on the diagonal between the interior trusses and peripheral edge beam on which was mounted 4ft by 8ft aluminum sandwich panels.

The Coliseum's exterior glass wall mullions are set on V-shaped concrete units. The glass curtain wall was design to be transparent, inviting for people to flow in and out freely. During the Exposition, the entire indoor space was used as one open exhibition space, thanks to the structure.

"The interior design concept utilizes a series of ramps and circular walkways which will make this one of the largest exhibition pavilions ever constructed. The building covers almost four acres and enclosed 160,000 square feet of unobstructed space within its glass walls."<sup>4</sup>

A card from C & H Sugar shows the bird's eye view of the exposition site, they sponsored a theater near the base of the Space Needle.



Water color drawing of proposed Washington State Coliseum

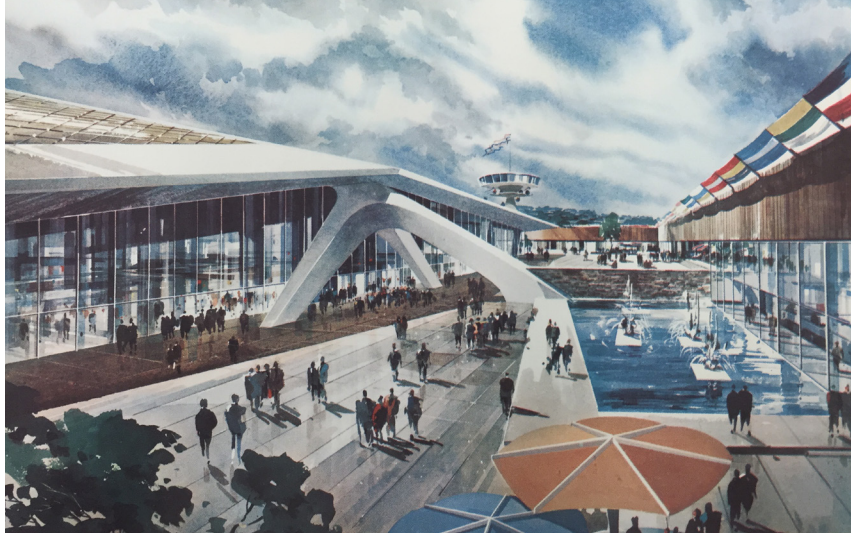

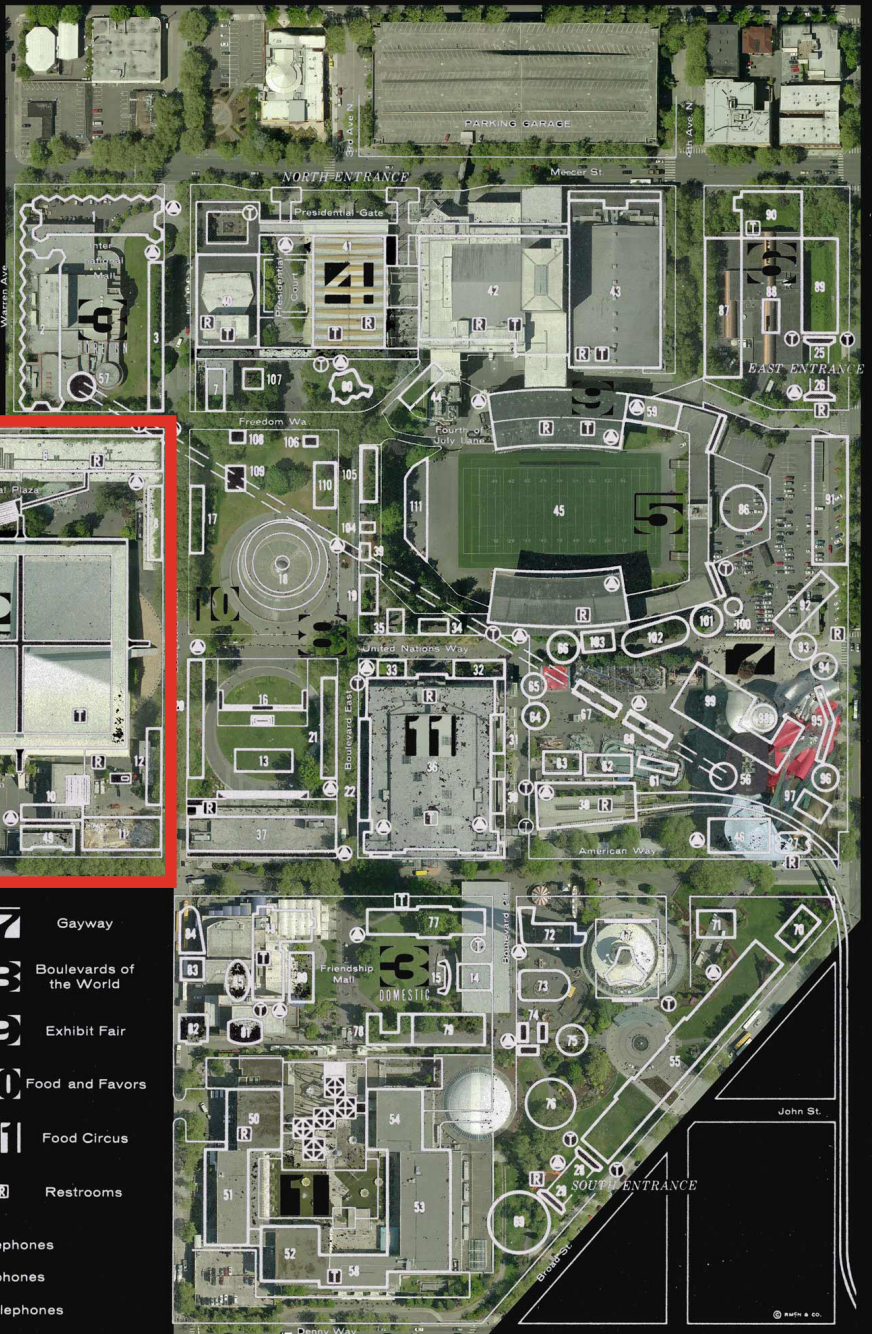

- |          |                                |           |                         |
|----------|--------------------------------|-----------|-------------------------|
| <b>1</b> | World of Science               | <b>7</b>  | Gayway                  |
| <b>2</b> | World of Century 21            | <b>8</b>  | Boulevards of the World |
| <b>3</b> | World of Commerce and Industry | <b>9</b>  | Exhibit Fair            |
| <b>4</b> | World of Art                   | <b>10</b> | Food and Favors         |
| <b>5</b> | World of Entertainment         | <b>11</b> | Food Circus             |
| <b>6</b> | Show Street                    | <b>R</b>  | Restrooms               |
| <b>T</b> | Outdoor Telephones             |           |                         |
| <b>T</b> | Indoor Telephones              |           |                         |
| <b>E</b> | Emergency Telephones           |           |                         |

- |  |                                |  |  |   |
|--|--------------------------------|--|--|---|
| 1. United Nations, African Information Center, Thailand, Philippines | 15. Horuchi Mural              | 47. Space Needle                             | 71. Forest Industries                              | 87. Backstage U. S. A.                                      |
| 2. India, Korea  | 16. State Flag Plaza           | 48. Club 21                                  | 72. "General Electric Living" Pavilion             | 88. Restaurant  |
| 3. San Marino, City of Berlin, Peru                                  | 17. Boulevards of the World    | 49. Administration Building                  | 73. Electric Power Pavilion                        | 89. Paris Spectacular                                       |
| 4. European Economic Community, Brazil, United Arab Republic         | 18. International Fountain     | 50-54. United States Science Pavilion        | 74. Transport 21                                   | 90. Paradise International                                  |
| 5. Japan   | 19-22. Boulevards of the World | 55. Interiors, Fashion and Commerce Pavilion | 75. Alaska Exhibit                                 | 91. Japanese Village  |
| 6. Mexico, Canada, Denmark   | 23. Fair Headquarters          | 56-57. Skyride                               | 76. Gas Industry Pavilion                          | 92. Wild Mouse  |
| 7. Boulevards of the World   | 24. Washington State Coliseum  | 58. United States Science Pavilion           | 77. Bell System Pavilion                           | 93. Meteor  |
| 8. Sweden  | 25-29. Restrooms               | 59. Exhibit Fair                             | 78. Standard Oil Pavilion                          | 94. Flying Coaster  |
| 9. National Aeronautics and Space Administration                     | 30-35. Boulevards of the World | 60. Home of Living Light                     | 79. IBM Pavilion                                   | 95. Fifth Avenue Building                                   |
| 10. Republic of China  | 36. Food Circus                | 61. Cake-Walk                                | 80. Christian Witness Pavilion                     | 96. Bubble Bounce   |
| 11. Great Britain  | 37. Hall of Industry           | 62. Broadway Trip                            | 81. Official Information Center                    | 97. Giant Wheel   |
| 12. Post Office and Boulevards of the World                          | 38. Monorail Terminal          | 63. Space Whirl                              | 82. Seattle-First National Bank, Century 21 Branch | 98. Rotor   |
| 13. Restaurant   | 39. Boulevards of the World    | 64. Space Whirl                              | 83. House of Tomorrow                              | 99. Skooter, Laff on the Farm, Trip to Mars and Concessions |
| 14. Restaurant   | 40. Playhouse                  | 65. Monster                                  | 84. "Sermons from Science" Pavilion                | 100. Carousel   |
|  | 41. Fine Arts Exhibit          | 66. Calypso                                  | 85. Nalley's Pavilion                              | 101. Olympic Bobs   |
|  | 42. Opera House                | 67-68. Concessions                           | 86. Islands of Hawaii Pavilion                     | 102. Hot-Rods   |
|  | 43. Arena                      | 69. Ford Motor Company Pavilion              |  | 103. Century 21 for Fun                                     |
|  | 44. Service Building           | 70. Christian Science Pavilion               |  | 104-110. Boulevards of the World                            |
|  | 45. Stadium                    |  |  | 111. Spanish Village  |
|  | 46. Fire Alarm Center          |  |  |   |

A 1962 map of Century 21 superimposed on the recent plan of Seattle Center. (Constructed by and courtesy of Ron Edge)

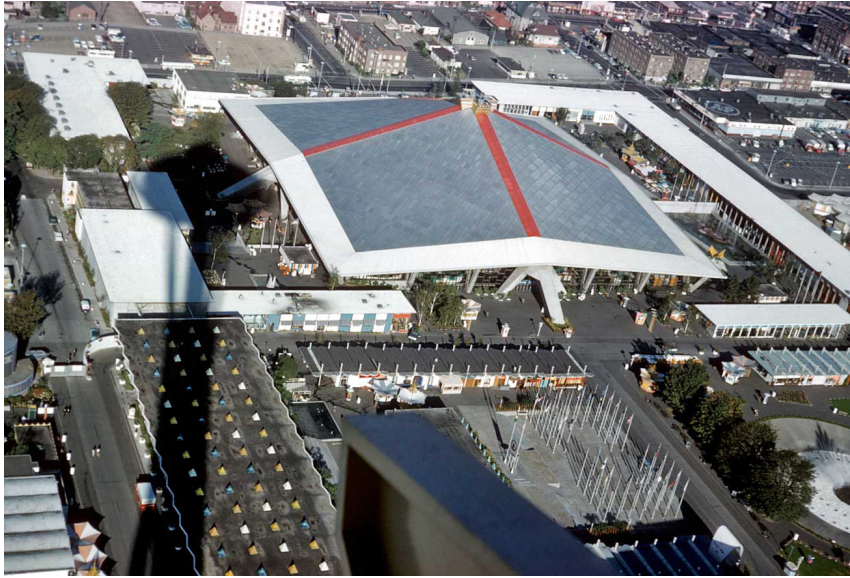

This photo looked west over the Washington State Coliseum into the Lower Queen Anne. On the left the shadow crosses was the Flag Plaza Pavilion which was replaced with the Fisher Pavilion.

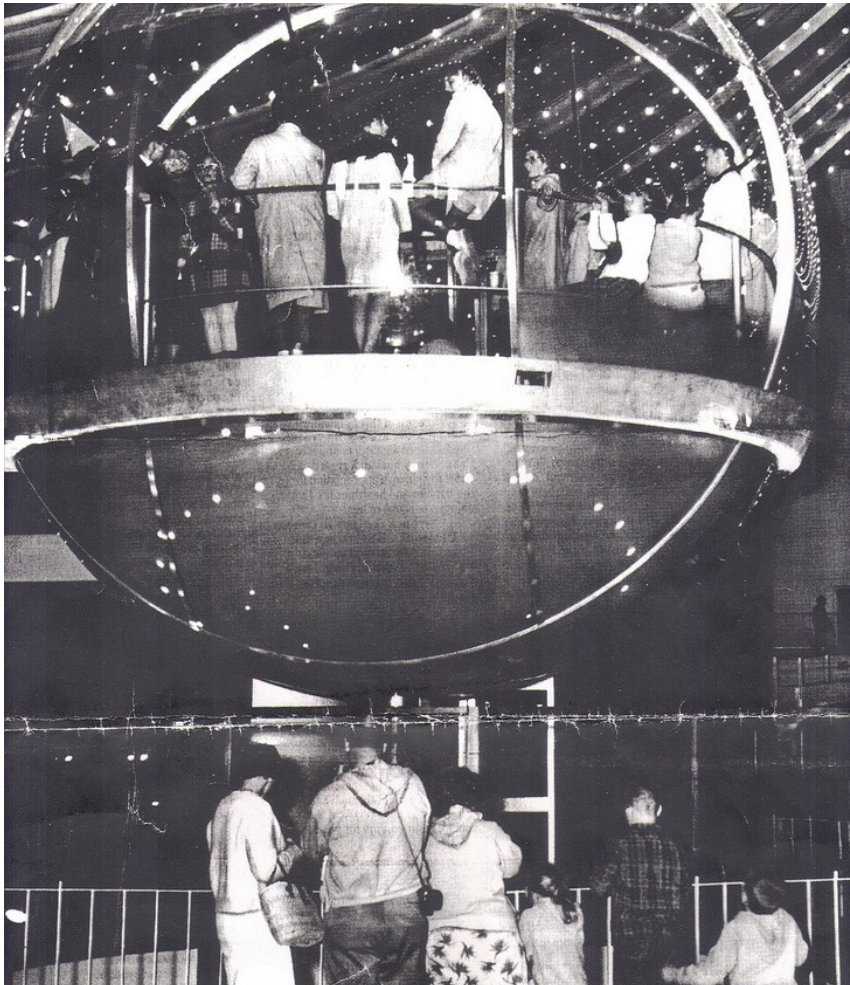

The World of Tomorrow exhibit housed by the Washington State Coliseum featured a glass-enclosed 100 passenger elevator called the "Bubbleator." Photo by George Carikonen / The Seattle Times



Victor Lygdman's construction stage photograph of the Coliseum's roof.



Interior scene under the majestic roof, the ramp and supporting structure of what will be the "World of Tomorrow." From a Seattle Times press shot by Paul V. Thomas for Jan. 3, 1962.

Photographs by Victor Lygdman. The visit with the "Lunchbox Crew" working on the Coliseum.



The three-legged gigantic concrete abutments from the exterior.





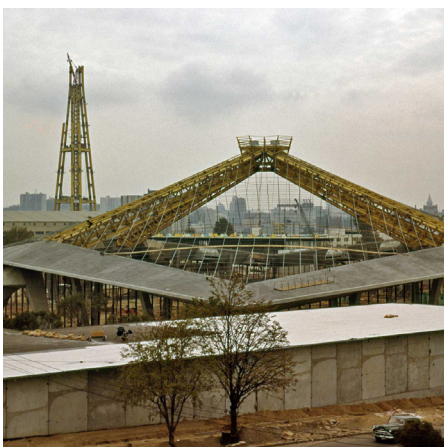
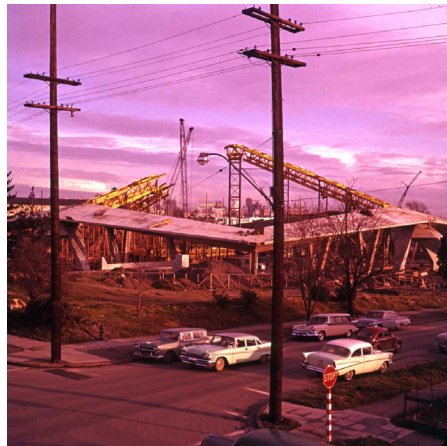

Photographs by Frank Shaw. Coliseum on construction 1959-1962

# 1964

## SEATTLE CENTER COLISEUM

It is a legacy of the 1962 Seattle World's Fair redeveloped to provide Seattle residents and visitors around the world with a cultural and recreational center. After the exposition closed, most of buildings on site were remained and converted as a new cultural center.

The City purchased the Coliseum from the State for \$2.9 million after the World's Fair. The building underwent an 18-month conversion into a venue for sports, concerts and trade shows, including installation of a seating bowl. It became known as the "Seattle Center Coliseum" then. An early tenant was the Seattle Totems of the Western Hockey League. And Beatles was among the early concerts held in the Coliseum. In 1967, the Coliseum became the home for the Seattle SuperSonics, an franchise expansion of the National Basketball Association (NBA). On Oct. 20, 1967, Sonics played their first home game in front of 4,473 fans. The Seattle Center Coliseum was not only a vibrant location for sports and cultural activities but also an important contributor to the regional economy. Other notable events during the 1970's were concerts by Elvis Presley in 1970 and the 1974 NBA All-Star Game.

The Beatles play for screaming fans who fill up the Coliseum at their 1964 performance in Seattle.



The Steven Pass sponsored summer snow jump from the Coliseum's roof. The photo dates from Aug. 27, 1966.



# 1993

## REMODELING AS KEYARENA

In 1993, seven years after the infamous “rain-out” of a Sonics game in the Coliseum due to a failing roof caused by huge deflection up to 2 feet in the wind, Sonics demanded the Coliseum be renovated. The City and the Sonics negotiated a revenue-sharing lease agreement designed to fund the \$100 million reconstruction of the aging, 30-year old Coliseum from building revenues, without dedicated public tax sources. This was unprecedented at the time for comparable new publicly-owned arenas. “In the agreement the city received 80% of suite revenues, 60% of club seat revenues, 40% of concession revenues from non-Sonics events, and title sponsorship revenues. The city’s share of revenues declined each year for ten years, under the theory that prices would go up, offsetting the percentage reductions, while the debt service on construction bonds would remain flat. The increasing percentages going to the Sonics would allow them to further invest in their team in order to stay competitive.”<sup>5</sup>

In 1994, the City Council approved a 15-year agreement with the Sonics and authorized \$73.4 million in 20-year bonds for Coliseum construction, renamed KeyArena as part of a 15-year title sponsorship agreement with KeyBank, which began in June 1994 and was completed in October 1995. Sonics played their first game at the newly christened KeyArena on November 4, 1995. The repayment for the renovation runs through 2014. KeyArena was the only major sports facility developed in Washington since 1995 without new tax revenue as funding source.

“The impetus for the 1993 renovations to the 30-year old Coliseum was to modernize the arena and keep it competitive for multipurpose users and retain the NBA Sonics franchise as the anchor sports tenant.”<sup>6</sup>

The first rain-out in NBA history, members of the Sonics staff looked up at the leaky roof of the Seattle Coliseum. The leakage postponed the game between the Sonics and the Phoenix Suns on Jan. 5, 1986.



Aerial view of KeyArena renovation during excavation.



With sentiment strong to retain the roof appearance and configuration, NBBJ designed a new roof and rigid-support system that, with added new ridge truss at the corners, maintains the roof's hyperbolic-paraboloid shape. These trusses bear on columns at the edge of the new bowl, directing the additional load from the new and heavier roof into the new columns to avoid increasing load on the existing structure.

One of many construction challenges in this renovation is the removal of the existing roof-cable supports. "The cables carried roof loads to the edge beam, which had been prestressed to resist the loads. Once the cable-roof loads that had countervailed the prestressing were lifted, the edge beam becomes unbalanced and wants to spring outward. To avoid resultant cracking, the engineers specified that new steel prestressing strands be added as the cable net was removed."<sup>7</sup>

With the superstructure of the old coliseum to be reused, the roofline and curtain wall structure to be preserved, to increase the capacity of the building within the same footprint and roofline required lowering the building. The seating bowl which was built after the fair, was structurally independent. Thanks to this feature, the old bowl was completely removed to allow the digging out the interior to drop the floor by 35ft. NBBJ was able to extend the original curtainwall downward to have little change to the exterior of the renovated KeyArena. "The new building included locker rooms for the Sonics and Thunderbirds, dressing rooms for concerts, an off-set hockey floor, a permanent rigging grid for concerts, a club seating program and 58 suites ringing the bowl."<sup>8</sup> The total cost of the renovation was 104 million.

KeyArena during renovation in 1994.



KeyArena renovation photo taken by Lara Swimmer during the installation of the roof structure.



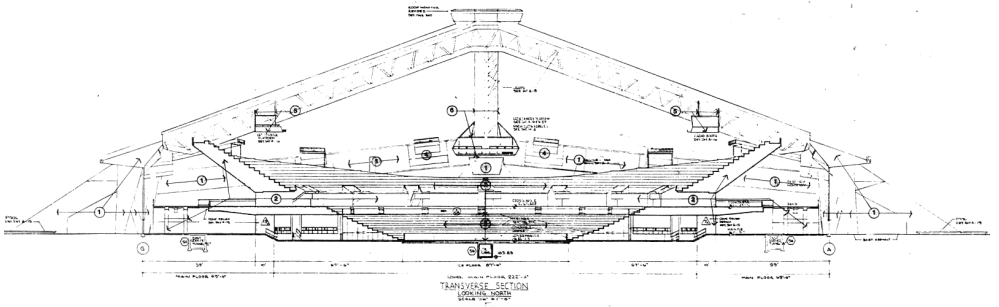
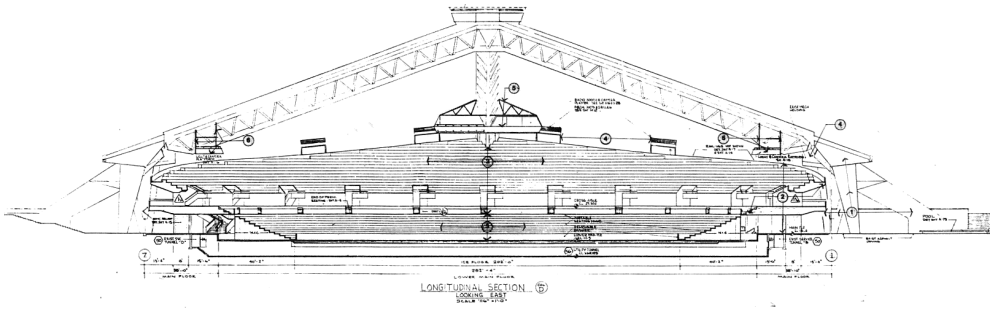

Above: Coliseum Building Demolition Longitudinal Section Looking East  
 Below: Coliseum Building Demolition Transverse Section Looking North



# 2008

## SONICS' LEAVE

As part of the Sonics lease, the City and Sonics committed to a program of major maintenance and refurbishments of the KeyArena around 2003 since KeyArena has significant issues that affected its financial health:

### 1. Undersized

With 368,000 square feet, KeyArena was the smallest arena in the NBA and is about only one-half the average square-footage of an NBA arena (about 700,000 sf). Its event floor, 35' below grade, was constrained by the original building buttress footings, resulting in smaller event floor.

### 2. Low Revenue Potential

Lacking the concourse size and the overall square-footage, KeyArena was too small to accommodate merchandising opportunities, food service and restaurants. It has only four concourses compared to other arenas (six or seven). KeyArena's square footage into revenue opportunities, operating efficiencies and the ability to adapt to ever-changing market conditions were hardly satisfied.

### 3. Original Funding Plan No Longer Working

"From the City's perspective, for the first five years of operation, the original financing plan was successful, with the building making a profit on an operating basis, and with the City's share of revenues from Suites, Club Seats, and Title Sponsorship sufficient to cover debt service on the \$73.4 million in construction bonds."<sup>9</sup> Since 2001, due to economic recession and competition from new venues such as Safeco field, the building revenues to support debts service had fallen \$12 million short. The Sonics reported losing \$58 million since 2001.

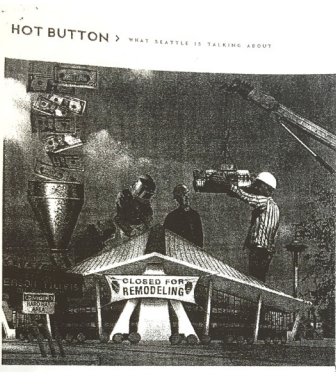

**HOT BUTTON** WHAT SEATTLE IS TALKING ABOUT

## Sonic Care

Another major-league sports club looks to taxpayers for a bailout  
By Blaine Newnam

**THE SPACE HEDDLE**, the enduring hood ornament of Seattle Center, is a reminder of the 1962 Seattle World's Fair and the city's coming age. While it continues to be the city's conic symbol, in the coming months the most talked-about building on Seattle's cultural campus is likely to be KeyArena.

Built originally to house the World's Fair Washington State Pavilion, and later becoming the Seattle Coliseum, it has served as the area's main concert venue—and since 1967 as home to the city's most successful sports franchise, the NBA SuperSonics.

The building's swooping roof lines, which suggested space travel in the 1960s, survived a 1995 remodel after Queen Anne neighbors and others demanded the original roof be saved and the building's footprint honored. But as nostalgic and important as the structure might be to Seattle, there are no guarantees about its future. The building's main tenant, the Sonics, wants additional remodeling to the tune of \$200 million, and a new lease.

It's a story Seattle has heard before. The Mariners were headed to Tampa Bay in the early '90s, the Seahawks to Los Angeles in the late '90s; both franchises were secured only after massive spending of public money—more than \$600 million—on new stadiums.

This will be a time, again, to question the propriety of spending big bucks on millionaire elites and owners, and to try to understand where a sports team fits in a city's priorities. And ask, frankly, whether a professional sports team can survive without public subsidy. The times say they can't. Reluctantly, they want a piece of the public pie on which the Mariners and Seahawks have already feasted.

"The city's position is that we want to keep the Sonics," says Seattle Deputy Mayor Tim Cole, as we're in the process of looking at the viability of KeyArena with and without the Sonics."

Next month the Sonics, and presumably the city, will head to Olympia for the second time looking for a bailout on the \$60 million needed to pay off the 1995 remodel, and to seek another \$200 million to remodel the building one more time.

At issue are taxes on meals and hotel rooms in King County that paid for the majority of both Safeco Field and Qwest Field. The Sonics want the taxes extended beyond their termination dates of 2013 and 2020, and only the state Legislature can OK such a tax.

It wasn't supposed to be this way. KeyArena was supposed to be a model for cities around the country.

In 1995, under an agreement that has proven too good to be true, the Coliseum was gutted and rebuilt, a \$73.4 million project that costumed the Sonics would pay here and the Coliseum would be competitive with the Tacoma Dome for concerts.

Best of all, it was to be done without taxpayer dollars: The Sonics would pay the majority of debt on construction bonds by frontloading up to 80 percent of the money the team received from the sale of suites and expensive club seats, as well as the money KeyBank was spending to have its name on the building (\$15.1 million over 15 years).

For a few years the deal worked. Revenues from suites covered loan repayments—and put \$1 million a year into the center's general operating fund.

But in 1998, the Sonics' season was cut short by a labor dispute, attendance dipped—and more significantly—corporations had a lot of suites to choose from. By 2002, with the Mariners at Safeco Field and the Seahawks at Qwest Field, the number of luxury suites in the city had swelled to 247, before the KeyArena remodel, there had been only a handful at the Kingdome, and those were neither luxurious nor sweet.

Last season, only 22 of the 59 KeyArena suites—which sell for \$55,000 to \$160,000 a season—were occupied. The idea of club seats—larger, softer seats with access to private restaurants and bars—was given up completely for lack of interest.

Seattle Magazine,  
December 2005, Topics  
about KeyArena's  
future use and Sonic's  
expectation.

Puget Sound Business  
Journal, October 31,  
2005. Discussion  
had been focused on  
financial problems of  
Sonics and KeyArena.

# Key revamp

## Funding no slam-dunk

By ERIC ENGLEMAN  
STAFF WRITER

Less than a year after their bid for a major KeyArena expansion failed to win support from state lawmakers in Olympia, the SuperSonics and Seattle Mayor Greg Nickels are warming up for a second try.

But some question whether a new proposal can come together in time to get any traction in the upcoming legislative session.

This spring, the Sonics and Nickels promoted a \$205-million, taxpayer-financed plan to expand KeyArena, nearly doubling the Seattle facility's size to 730,000 square feet and adding more concourses, concessions and dining areas. They also asked for an additional \$55 million to retire the remaining debt from the arena's last renovation a decade ago. The plan would have given the Sonics full management of the city-owned facility.

The plan was sold as a way to stem mounting financial losses for both the Sonics and

**TICKET SALES EFFORTS SIZZLE**

Ticket sales are up this year, but the Sonics insist if KeyArena isn't remodeled the team may move.

While the Seattle SuperSonics and KeyArena look for a way out of their financial doldrums, the Sonics are reporting some positive news on ticket sales. The team is also tweaking its seating chart, hoping for more income from corporate buyers who've strayed to the new baseball and football stadiums.

See SIZZLE, Page 61

See SONICS, Page 67

#### 4. Operational Inefficiency

The lack of space for operations, event loading and storage adversely affected all events in KeyArena, made the building more expensive and less efficient to operate.

From 2003, the Sonics expected both a modernized competitive facility and lease agreement that would enable them to be financially successful. They expected KeyArena to be remodeled again, providing more space to generate revenue, or relocating to a new arena elsewhere in the Seattle metropolitan area. A concept study of possible major renovations to KeyArena that would bring it up to current NBA standard and explore revenue generating enhancements was led by SRG Partnership and 360 Architects, resulted in an estimated total project cost of \$200 million (in 2005 dollars). There was a time a lot of disputation being discussed around 2003 to 2008. Failing into making an agreement with the City on additional remodeling plan and the new lease, the Sonics team relocated to Oklahoma City in 2008, and now plays as the Oklahoma City Thunder. The lease agreement between the Sonic and the City expired September 30, 2010. Without Sonics, KeyArena then becomes a large events venue continued to host dozens of nationally touring concerts, Sports games, family shows and conferences.



# Chapter 2:

## Nowness

**now·ness** *noun* \ˈnaʊ-nəs\  
: the quality or state of existing or occurring in or belonging to the present time.”<sup>1</sup>

Since the ever-changing social context is pushing people’s life forward, how to keep buildings being relevant with the present time is important and challenging. To prevent them from outdated, the way of updating in which one can add a new dimension, a new function, a new beauty or appeal, to synchronize the old with the new context is the approach of nowness. This chapter discusses the present social context around Seattle and Uptown neighborhood which gives an insight for KeyArena’s renovation proposal.



# URBAN CENTER

## DENSIFICATION OF NEIGHBORHOODS

KeyArena is located at the very heart of Seattle's Uptown Neighborhood.

Uptown is one of the fastest growing neighborhood in Seattle, where prediction sees gains of 3,000 households and 3,500 jobs by 2035.<sup>2</sup>

Because of its proximity to Downtown, the whole region of Uptown is designated by the Office of Planning & Community Development as Urban Centers and Villages, and needs to accommodate future population and job growth and help guide city planning policies in the four core values: Community, Environmental Stewardship, Economic Opportunity and Security, and Race and Social Equity.<sup>3</sup>

Due to these demands for densification in the recent years, many of the original zoning height of NC3-40 (Neighborhood Commercial 3 with 40' height limit) has been updated to NC3-65. Further evaluations are underway for further upzoning to NC3-85 or even NC3-160.

The KeyArena is an anchoring landmark to the ever growing community. It needs to have public supporting functions to help facilitate a healthy development of the neighborhood instead of a singular event function that is closed most time of a year. KeyArena needs to be not only physically at the heart of the Urban Center, but also functionally supporting the Urban Center's development, while providing a healthy and efficient mode of transportation.

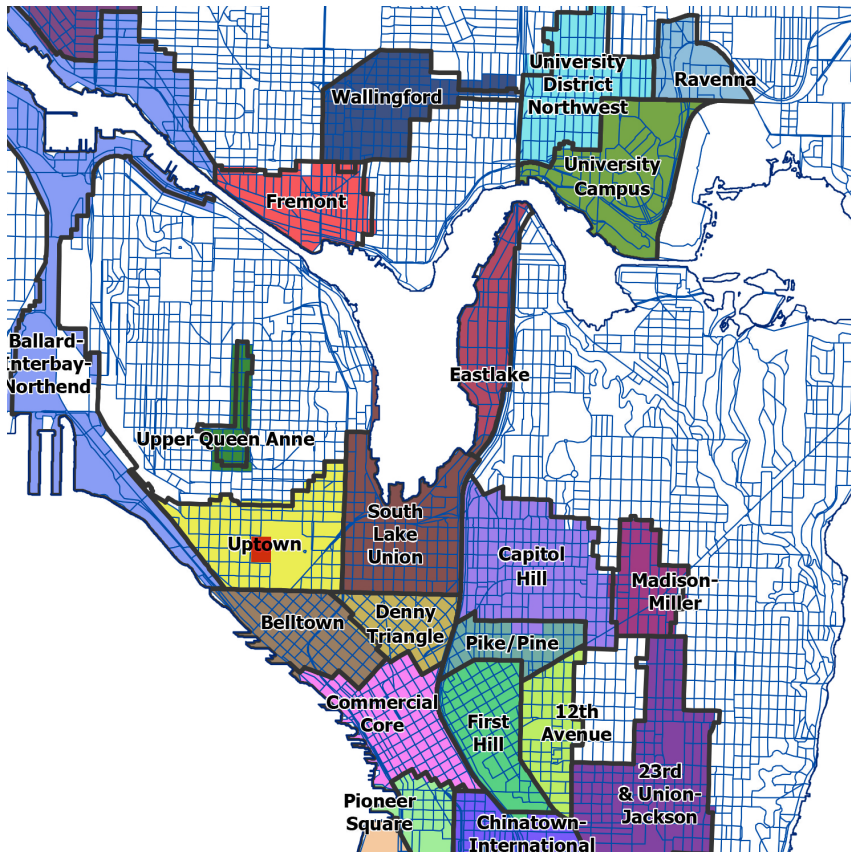

Map showing Seattle's urban center and village. The whole area of Uptown is so designated.

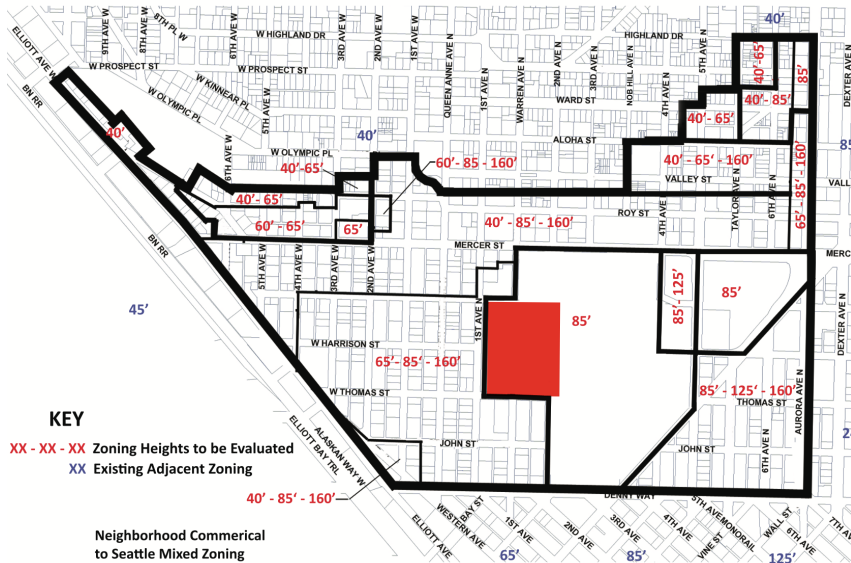

Areas of Uptown surrounding KeyArea are under upzone evaluation.

# SEATTLE CENTER STATION

## SOUND TRANSIT 3 LINK LIGHT RAIL BALLARD LINE

The voters of Central Puget Sound region have passed the Sound Transit 3 proposal in 2016's election. With this decision, people have supported the continuation of building the true mass transit system that has been talked about for years.

According to King County Council Member Joe McDermott, "This plan will deliver fast, reliable light rail to West Seattle and Ballard, which is forecast to be the highest used segment in the system."<sup>4</sup> This development is essential to accommodate the projected 35% population growth, and 42% employment growth according to Vision 2040.<sup>5</sup>

The Ballard to Downtown Seattle line is currently planned for service in 2035, and will provide station at South Lake Union, Seattle Center, Smith Cove, Interbay, and Ballard.

The Seattle Center station will serve riders from the Uptown neighborhood, one of the fastest growing neighborhoods, along with great number of visitors to Seattle Center. The incorporation of Link light rail station in this vicinity fulfills the goal of having a strong multi-modal transportation system indicated in Uptown Urban Design Framework that will balance Uptown's future capacity to grow with safety and livability.<sup>6</sup> And by locating the Link station actually within KeyArena, it provides important connection between local historical architecture and contemporary functionality, and local residents and global tourist.

# BALLARD TO DOWNTOWN SEATTLE LIGHT RAIL

- MAP KEY**
- ELEVATED
  - ■ ■ ■ ■ TUNNEL
  - STATION AREA
  - LIGHT RAIL SOUND MOVE/ST2

*Alignments and stations shown are representative and are identified for purposes of cost estimating, ridership forecasting and other evaluation measures.*



Route proposal for Sound Transit 3 Link Light Rail Ballard Line.

# ELEMENTARY SCHOOL

## MISSING PIECE FROM 1959

The northeast quarter of the site where now KeyArena sits used to be the site for Warren Avenue School. Established in 1903 with 350 students, it grew to 734 student in 1929. It was the pioneering place where student with cerebral palsy are first welcomed in Seattle in 1944, also programs for blind and sight-impaired children began in the same decade.

However, by the 1958–59 school year, enrollment had dropped to 250 students, steadily declining as families moved away because of impending clearance of the neighborhood for the World's Fair grounds. "The school district sold the site after the State Supreme Court ruled that the state could condemn the preperty ..... students were transferred to West Queen Anne or John Hay, with the cerebral palsy group going to Holgate, the blind children to John Hay, the sight-saving to Coe, and the hearing-impaired to Green Lake. When the Century 21 Exposition opened in April 1962, the former school site was subsumed by the Washington State Coliseum, which housed international exhibits. It is now the site of Key Arena."<sup>7</sup>

As of 2017, an elementary school is still a missing piece in this region. With increasingly denser population around Downtown, Belltown, South Lake Union, and Uptown, the need for a local elementary school is widely under discussion. And there is a great opportunity for KeyArena to fill in the missing piece from 1959, to restart what was demolished here again.

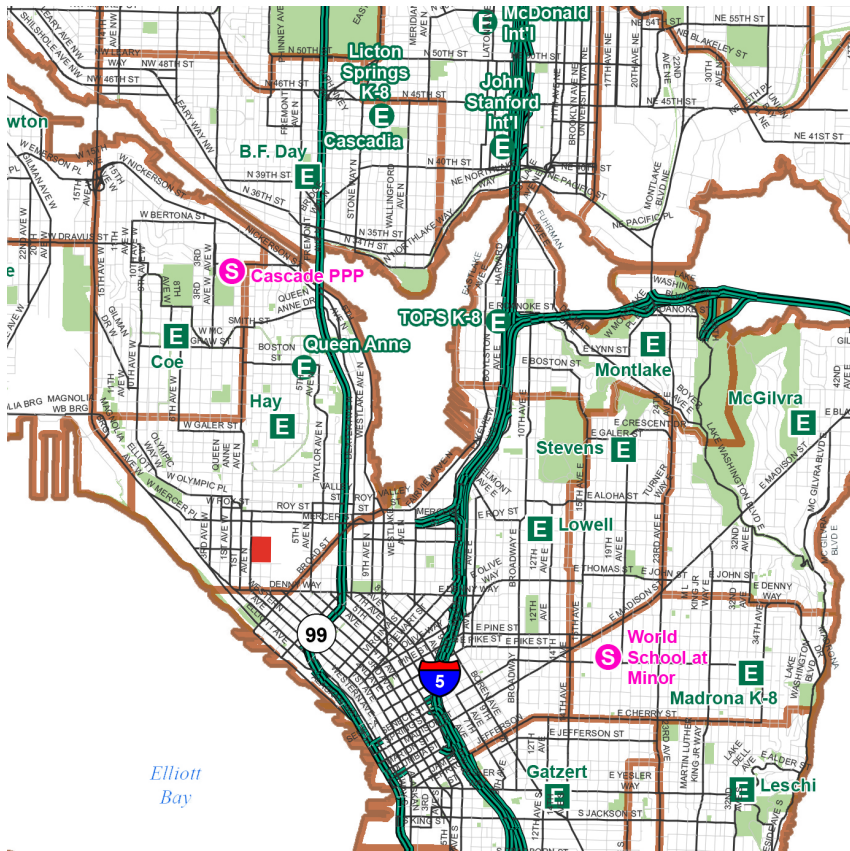

Seattle school district's attendance area map showing missing elementary school around KeyArena.



The original Warren Avenue School in 1905

# PUBLIC PLAZA

## MAIN AXIS AND MARKET PLAZA

Since 1962, Seattle Center has been developed from the World's Fair ground to a civil and cultural complex with museums, galleries, ball rooms, theatres, and etc, especially on the main axis where KeyArena has its south side facing. On the main axis, from east to west, has the Experience Music Pavilion, the Space Needle, the Monorail station, the Chihuly Garden and Glass, the Armory, the Fisher Pavilion, and the Children's Theatre holding their frontage to.

However the main axis terminates at the southeast corner of KeyArena as the skatepark and then becomes loading dock. The main axis fails to anchor the west end with one of the most significant building of Seattle Center, the KeyArena.

The south side of KeyArena where is currently being used primarily as loading dock, has great potential to be a public plaza where daily event activity or weekly farmers market can be held. A simple size comparison between the south plaza of KeyArena and world's famous public plazas, the Piazza del Campo and Pompidou Plaza, show amazingly similar dimension.

The possibility of using the south side of KeyArena as a public plaza to anchor the west end of the main axis is promising, with huge opportunity to not only benefit the tourists who come to Seattle Center, but also contribute to local culture due to its proximity to surrounding residential neighborhood.

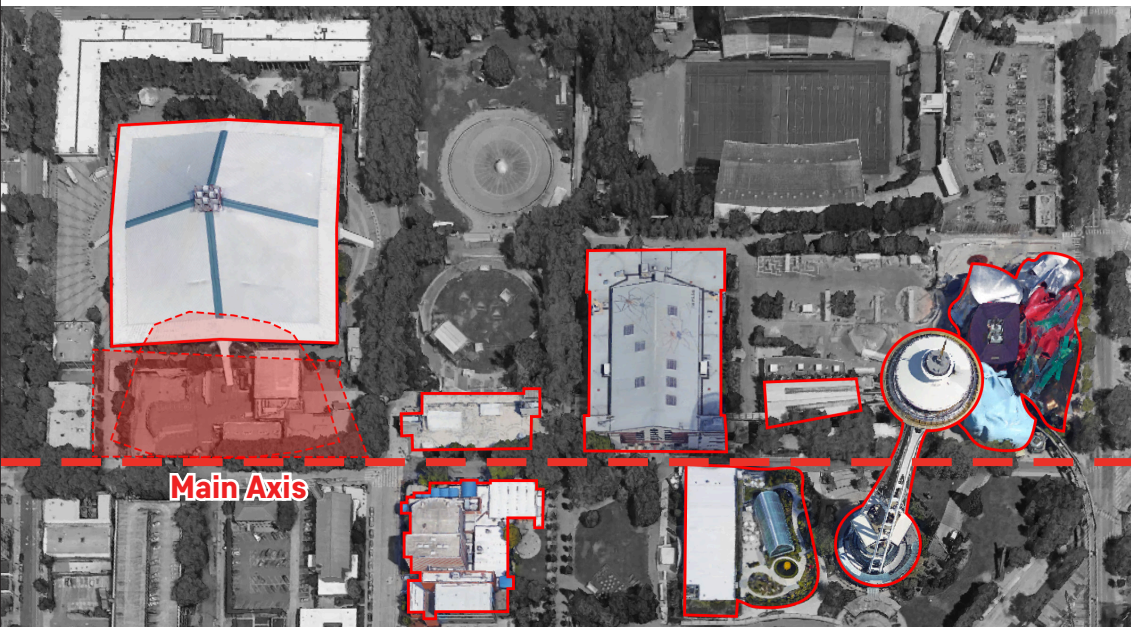

**Main Axis**

The south side of KeyArena lands on Seattle Center's main axis where EMP, Space Needle, Monorail station, Chihuly Garden and Glass, Army, Fisher Pavilion, and Children's Theatre face.

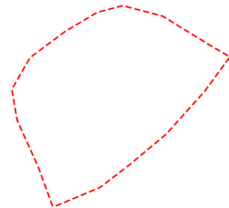

The size of Piazza del Campo of Siena, Italy

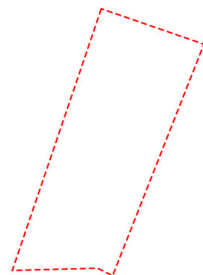
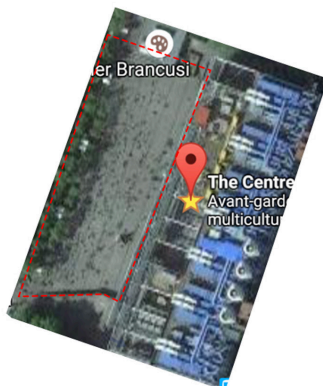

The size of the plaza in front of the Pompidou Center in Paris, France

# Chapter 3:

## Pre-Proposal

Witness and Nowness are on the lineage of time, but not yet sharing the same moment in time. Serious work is required to assess, analysis, and research issues that are segregating the two, in order to find the heal.



# CURRENT CONDITION

## SITE VISIT

The dilemma of KeyArena is that it can be filled with energy during the event, but as soon as people have gone, it becomes empty and silent, completely shut down its door without a hint of activity even in the daytime. It is usually either absent or incredibly heavy-loaded, lacking of an in-between condition. This is caused by its static usage, and outdated infrastructure for flexible programs. The building itself is shielded by down-going stairs and lush vegetation. In fact, the simple act of walking around it is not even a straight-forward experience. To re-imagine a better condition for KeyArena, It is important to understand the current problems and potentials.

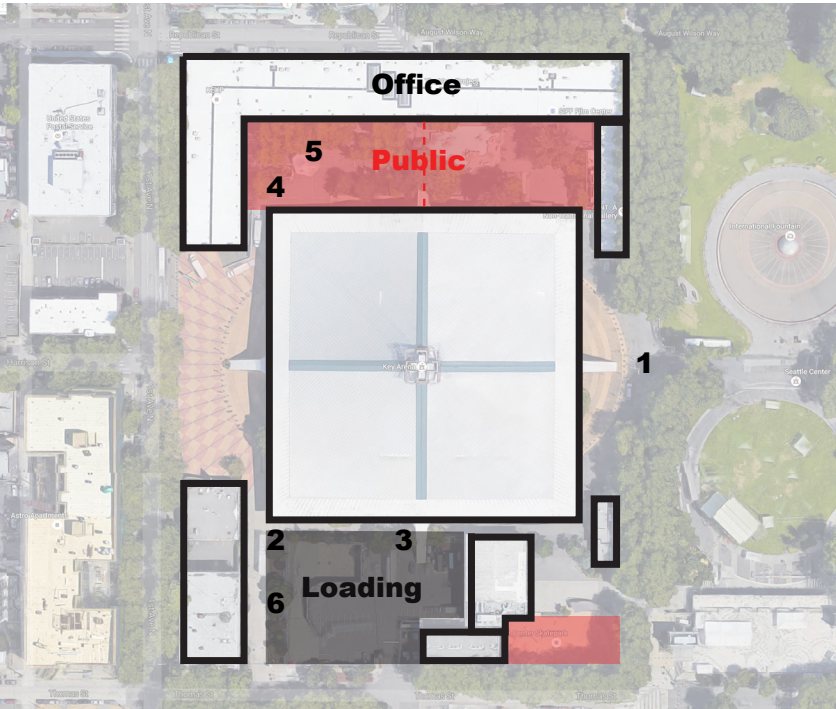



1. The east facade of KeyArena is the most noticeable side. But its sunken entrance and closed door turn visitors away despite their curiosity about the building.



2. The edge where KeyArena meets ground is lush with vegetation of all sorts, and kept away from visitors by raised planters. The vegetation blurs KeyArena from people's perception.



3. Because the 1993 renovation has dropped KeyArena by 35', there are many stairs in its surrounding connecting height difference while obstructing the flow of people.



4. The ground has different height relation with KeyArena's roof. For example, at the northwest corner, the building is very intimate to people because the ground is higher than other corners.



5. The north courtyard is hidden away by surrounding buildings and is very little used, despite it is actually a pleasant public space created by rows of trees.



6. Large portion of the south side of KeyArena is used as loading dock that is mostly empty. This part has great potential for its strong visual connection to Space Needle, and easy accessibility from neighborhood.

# PROGRAMS

## RESPONDING TO NOWNESS

New programs need to provide flexibility so that different group of people can get access to different space of the building in different time, in the day or night, based on their needs. They also need to encourage pedestrians to penetrate into the building, improving the building's public exposure. Hybrid programs such as restaurant, commercial, educational uses that spans across different time periods should coexist with public open space on the site. A successful public space opens itself to the public, creating opportunities to strengthen visual connection with surrounding, and allow people to stay, easily get through or interact with the site. A public space can also help eyes on the street, promoting security in the neighborhood. When event is undergoing, convenient public transportation allows people to come and leave without congesting surrounding traffic. The update to KeyArena aims to make it not only in people's daily panoramic view, but daily life as well.

According to the research on social and urban context of KeyArena in chapter 2, as well as considering the possibilities to revitalize this history landmark, potential programs include:

1. Link station with 400ft platform

Sound Transit is planning for Ballard to Downtown Light Rail that will have a station at Seattle Center. The station will serve riders from the Uptown neighborhood along with great number of visitors to Seattle Center. This makes the vicinity of KeyArena to be the most attractive location to place the station for its proximity to all surroundings. Also for the ease of construction, the south of KeyArena is currently off limit to public, and way oversized as loading zone, which will easily be converted into staging area for the tunnel digging. By having the link

station at KeyArena, it presents the potential of having it actually under KeyArena, activating the KeyArena from inside-out, converting it into a multifunctional destination through out the day.

2. The sports/concert arena

3. Elementary school 40,000sft minimum

KeyArena sits on a location where historically have been four city blocks. Among which there used to be a public elementary school demolished for the construction of KeyArena, that served the adjacent residential neighborhood. Since its demolition, this elementary school has never been replaced or relocated. Now as the Uptown neighborhood is rapidly growing its density, the need for an elementary school to support a healthy neighborhood is urgent. As the KeyArena is being updated to share space, the integration of a school will also provide the chance for students to use the stadium while no other venues are using it, which also eliminate the necessity for the school to build its own dedicated sports field.

4. Market (indoor/outdoor)

5. Retail

6. Concourse/Restaurants

7. Public space (south plaza) 80,000sft

KeyArena sits at the north side of the main axis of Seattle Center. It is more suitable to be a public plaza that welcome the visitors and the residence from adjacent neighborhood to come and enjoy. Especially in the current condition where KeyArena and its skirt buildings are a huge urban edge and obstacle for the locals to get into Seattle Center. By providing a public plaza, KeyArena will be able to blur its hard boundary and also strengthen the main axis of Seattle Center.

8. Office

# PRECEDENT STUDIES

## THE HINTS

This thesis attempts to answer how forward-thinking preservation could effectively and actively revitalize the historic landmark into a multi-functional building with public space and community uses. As part of our

London Design Museum



Markthal Rotterdam



thesis, we traveled to see many successful projects in person, including transportation hub, market, museum and other mixed-use buildings. These precedent studies help us better understand the tremendous potential of multi-functioned public project contributing to the city and individuals, providing hints and inspirations to our thesis.

Souterrain Tram Tunnel



Path - World Trade Center Station



## LONDON DESIGN MUSEUM

### OMA(MASTER PLAN), JOHN PAWSON(INTERIOR): RENOVATION

The original building was designed by Robert Matthew, Johnson-Marshall and Partners, and was completed in 1962 as Commonwealth Institute. However since 2002, this building has stood empty and been closed to the public. In 2006, the grade II listed building (one of the highest protection ratings in the UK), was on the risk of demolition after a failure to delist it.

In December 2007, along with five other architectural firms, OMA was invited to consider the potential future and study the opportunity of the Commonwealth Institute site. "OMA's design seeks to save the building by re-injecting life into the modernist monument, the new home for London's Design Museum, while retaining its distinctive copper roof and parabolic form. New residential accommodation will integrate into the existing fabric of the site, regenerating the western end of Kensington High Street."<sup>1</sup>

The interior was designed by local designer John Pawson, who commented "I think it's marvelous to have been able to save the building, and have it now as what's going to be a world-class center for design."<sup>2</sup>



The original condition of Commonwealth Institute was threatened with demolition.



The renovation by OMA included basement excavation, upgrading screen and structure system. The whole site was added with residential development.



The interior space was converted into a design museum preserving the massive atrium of the original building by John Pawson.

## MARKTHAL ROTTERDAM

### MVRDV: INDOOR MIXED-USE MARKET HALL

"New laws in the Netherlands require covered areas for traditional open air meat and fish markets due to new hygienic constraints."<sup>3</sup> Two questions have been posted by MVRDV in response to these challenges: "Can we use this operation to evolve the market typology as well as densify the the city centre?" and "Can we increase quality as well as density of programming at Blaak?"<sup>4</sup>

This building provides various spaces for restaurants, market, retailers, living and parking. These spaces are all fully integrated to make the most of the combined possibilities of different functions. The central market hall is a covered square placed within an arch building formed by apartment units. This design is so unique and thought-provoking because it allows private investment to provide a public space. At night it remains lively thanks to restaurants on its first floor.

The section of this building is uniquely dynamic in terms of visitors' circulation. The market space opens to pedestrians from two ends on ground level, and welcomes automobile visitors from central atrium space that connects down to all parking levels. There is also a 24/7 grocery store located in the basement serving residence and people around.



The plan shows the ground level restaurants and the layout of vendor stalls.

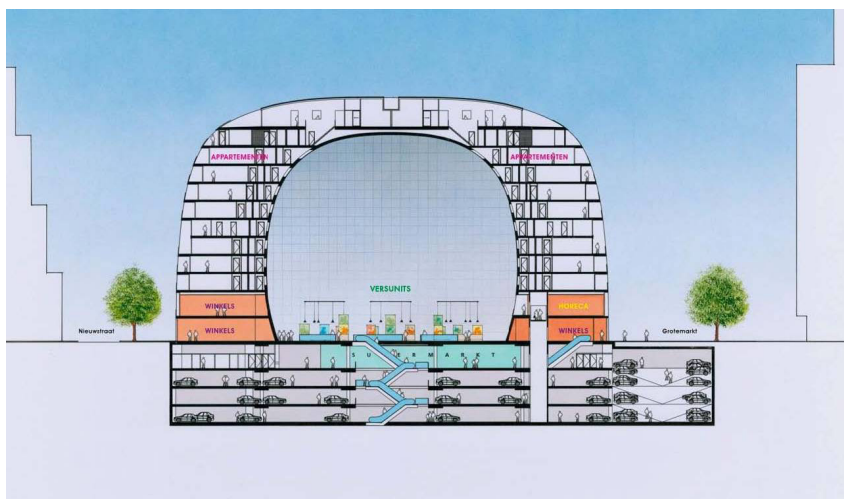

Dynamic section of the market hall.



View from the indoor market towards the residential arch, the vertical circulation and retail space on the lower level,

## SOUTERRAIN TRAM TUNNEL

### OMA: INSERTED UNDERGROUND TRANSPORTATION

"The souterrain tram tunnel is an element of infrastructure and a building at the same time."<sup>5</sup> This underground tunnel is located at the city center of Hague, Netherlands, providing 500 parking spaces on the first level and tram stations on the next level below.

This tunnel-building is an enhancement that makes all the other buildings around it connected underground and well-functioned: "The tunnel acts like a spine connecting the separate 'organs', creating a body of underground connections that serves the city from underneath."<sup>6</sup>

Stretching out below the main shopping street for 600m, consideration has been taken to overcome the boredom of a long continuous section. Every opportunity has been taken to modify the height and the width of the space, to connect physically or visually to other parts of the tunnel's program, to provide views to the outside, to bring down light, to link the tunnel with surrounding shops and parking.

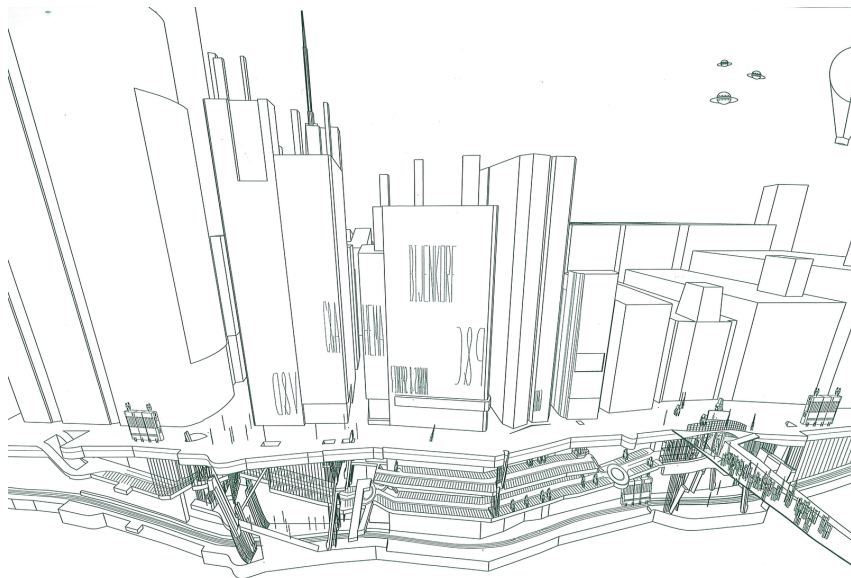

This tunnel building connects the other buildings underground, serving the city from underneath.



Opening brings light down to the tunnel building, providing rich experience for people.



Circulation is well integrated with different spaces and functions.

## PATH - WORLD TRADE CENTER STATION

### SANTIAGO CALATRAVA: NEW STATION/RETAIL MIXED-USE

The World Trade Center Transportation Hub, designed by Spanish architect Santiago Calatrava, is a complex structure and home to public plaza, stores, restaurant, subway and train terminal. This project anchors the missing piece since 9/11.

The transportation hub consists of “an elliptical winged pavilion, referred to as the Oculus,”<sup>7</sup> which serves as the main concourse space. The steel ribs and glass array in a large ellipse to form the “Oculus” by the image of a bird released from a child’s hands. Thanks to the beautiful structure, natural daylight floods into the main piazza space. The white marble flooring makes the interior even brighter. Two levels of retail space ring around the Oculus, providing people with stores and commercial activities. The building’s unique and sculptural form also help identify the outdoor as well as the indoor public space in New York City.

Steel ribs array in a large ellipse to form the column-free Oculus space.



Two levels of retail space ring the piazza. It also serves as pathways link to subway and adjacent buildings.



The PATH Hall provides ticketing for access to the subway lines. This space is also defined by parallel steel ribs.



# INSPIRATION

## TSUGIKI

Tsugiki in Japanese, or grafting, is an agricultural technique to join tissues of plants as if they are grown together. Branch grafting is a technique commonly used in the making of Bonsai where same type or different types of trees or branches are joined to create certain aesthetic appeal, or for the benefit of the tree's health by using a stronger type's root. This technique is used to take advantage of the best of both the original and the grafted branches.

Tsugiki is used in the making of Bonsai.



## YOBİ-KİN-TSUKUROI

Kin-Tsukuroi means “golden joinery” in Japanese, and it refers to the art of fixing broken ceramics with a lacquer resin made to look like solid gold.<sup>8</sup> Yobi means “borrowing” and Yobi-Kin-Tsukuroi refers to the kind of fixing that uses pieces from different original ceramic. And at time, it can also borrow pieces of other materials such as glass and wood. With this technique, instead of throwing away the broken piece of ceramic, it is brought back into life and turned into a piece of art that carries on the memory of all pieces it contains.



# Chapter 4:

## Proposal

We propose liberating KeyArena without adding height or blocking views from surroundings and utilizing the underground spaces beneath it. In this way, we provide new spaces for visitors, school students and residence of the neighborhood, open up historic interiors, and create a new underground network of spaces - accessible from multiple points within the arena - for events, daily uses, preparation, and storage. In addition, we propose a new link station to the heart of KeyArena, bring people from underground to the inside of KeyArena as well as the neighborhood.

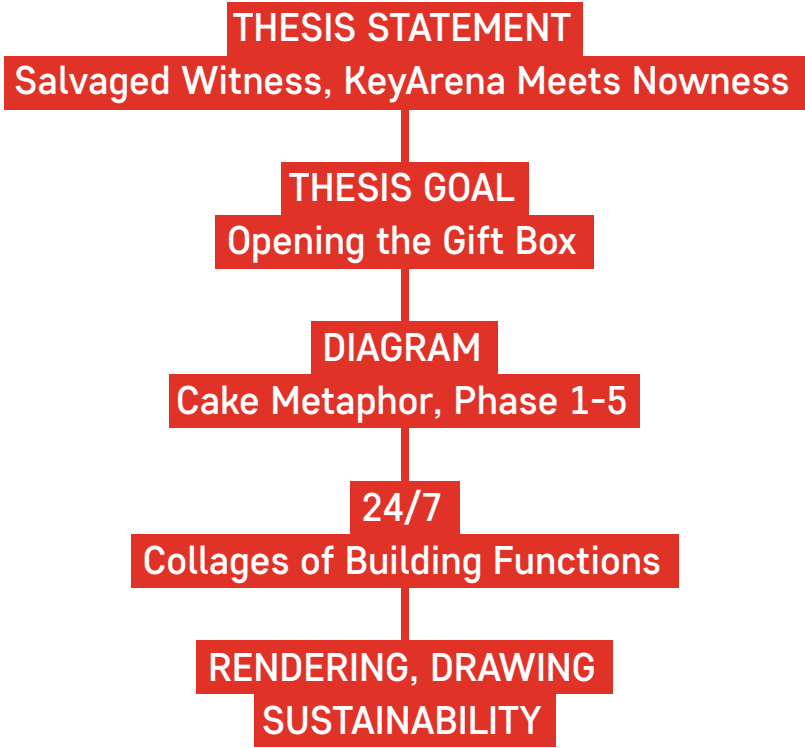

"The beauty about preservation is to begin with something that already exists and therefore is already local. By definition, a preservation project is an homage to earlier cultures and mentalities to which you can add a new dimension, a new function, a new beauty or appeal."<sup>2</sup>

- Rem Koolhaas



# THESIS STATEMENT

## SALVAGED WITNESS, KEYARENA MEETS NOWNESS

KeyArena is a witness of history and an underused masterpiece. It roots deeply within the history of Seattle, but its obsolescence fails to sustain its desire to be actively used. KeyArena is a local landmark but fails to keep up with the pace of nowness. Therefore, its humble form, stunning structure and center for civic activity needed to be salvaged. This thesis seeks to explore an approach of unconventional preservation project that is an homage to diverse layers of time. Existing and newly inserted conditions confront and interact with each other, offering an ensemble and coexistence of fragments that will not be depicted by a single image, or allow any part to overtake the others. New, old, horizontal, vertical, wide, narrow, light, dark, over, under, open, enclosed...All these oppositions establish the range of complexity in architecture that define the new dimension of salvaged KeyArena, which transforms the witness to the heart of nowness.

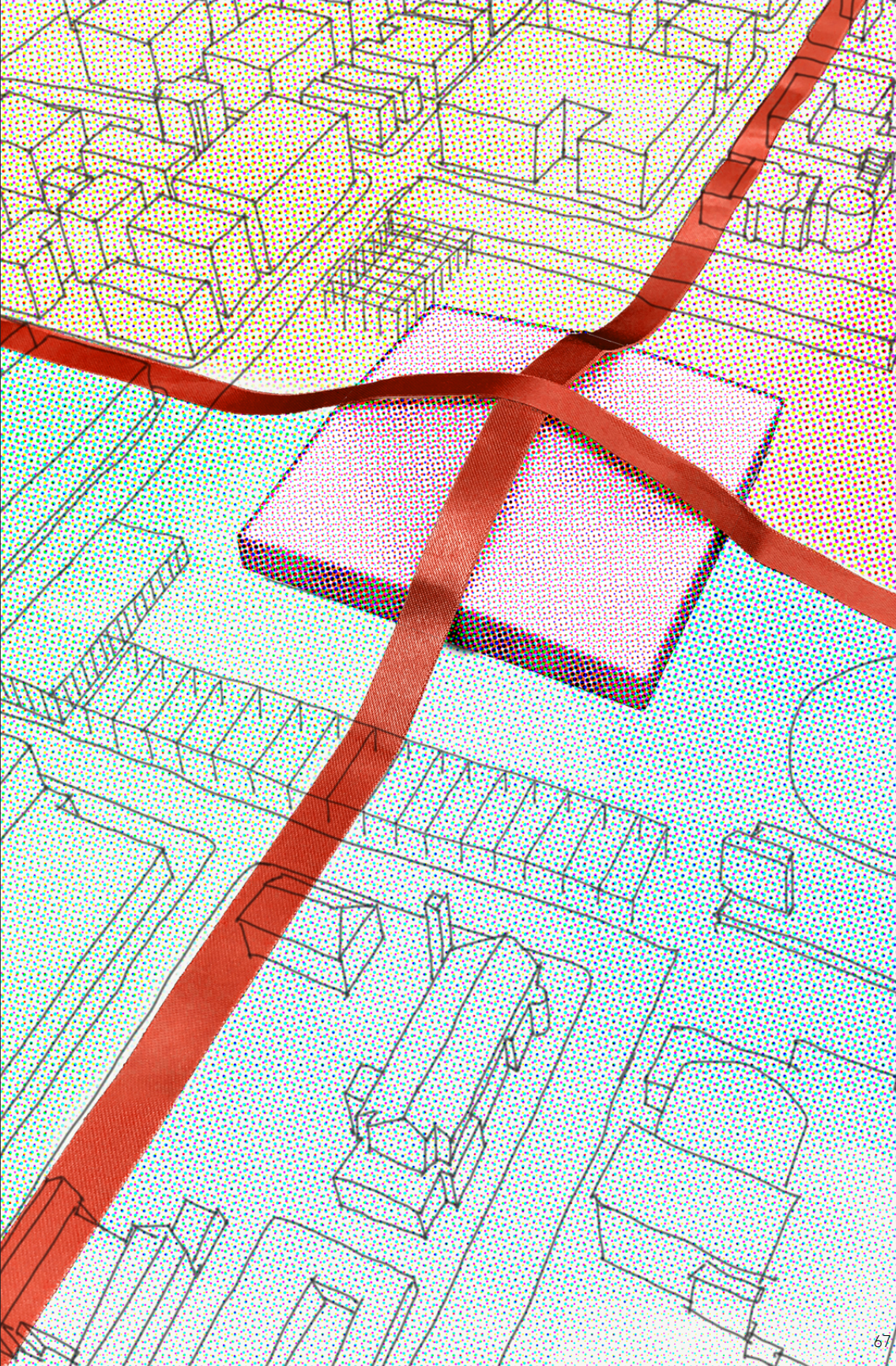

# THESIS GOAL

## OPENING THE GIFT BOX

KeyArena with its red neon sign on top, resembles the ribbon on a closed gift box. This is exactly the situation of KeyArena. Without an event, the building is completely closed off to the public. With an event, it is also limited access only to ticket holders. Despite its stunning architectural quality and profound historic importance, KeyArena is extremely underused. It needs to be opened.



KeyArena resembles a closed gift box, where people have very limited access to it.

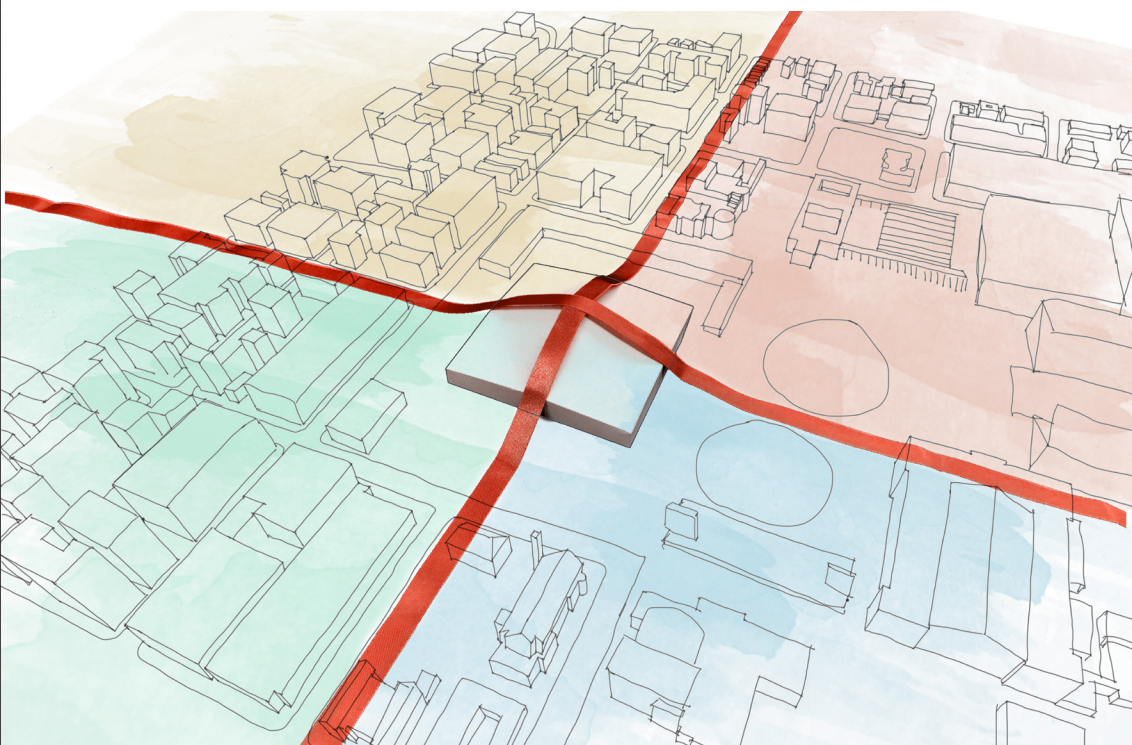

This thesis propose  
to open the gift box,  
revealing the inside of  
KeyArena for people to  
experience freely.

# DIAGRAM

## CAKE METAPHOR

Inside of KeyArena gift box sits an old and plain cake. The cake metaphor illustrates the preservation and renovation process this thesis proposes to salvage the KeyArena to meet the nowness.



The inside of KeyArena resembles an old cake that is plain and closed off to people around it.



The old cake is cut in half to reveal the actually yummy heart so that people start to notice its hidden beauty.

A new transparent jello cake with new programs is added, but intentionally leaving gaps between old KeyArena cake.

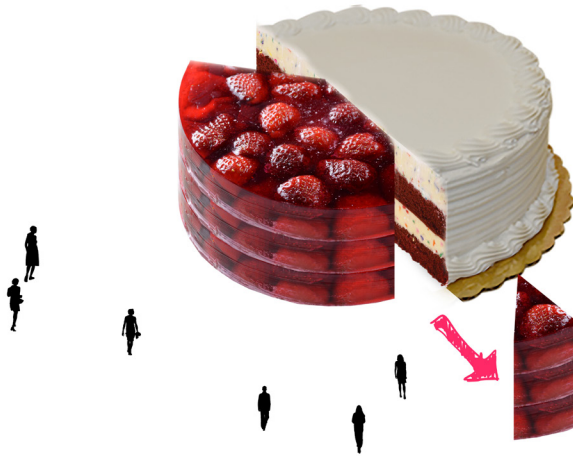

The gaps then become the entrance to the building, welcomes people's exploration

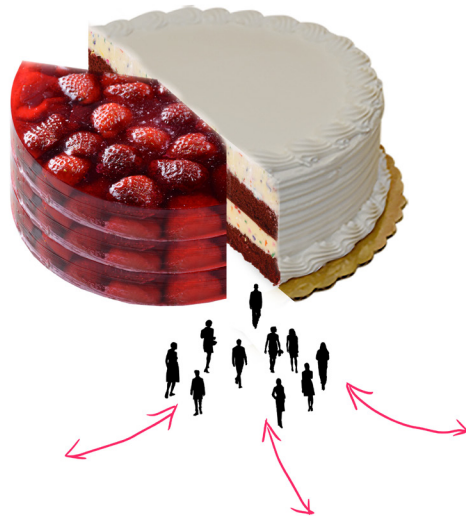

## PHASE 1: DEMOLITION

In the first phase, approximately 50% of the old seating bowl is proposed to be demolished along with the floor structure. This move kicks off the renovation by getting rid of underused old structure to make space for new, more contemporary, and much needed functions.

1/3 of seating plan from the south, and the lower half of 1st level seating are cut away. This cut location is ideal for it gains the most salvaged surface area comparing to the loss of seating amount.

The cut also reveals the sectional layering condition of the existing floors, which will be exposed and incorporated into the side façade system, creating clearer visual understanding and distinguishing between the old and new structure.

The vacated space opened up from the demolition will create space that facilitates new construction.

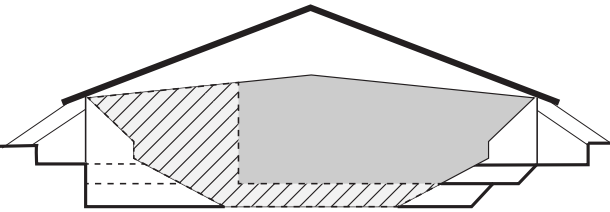
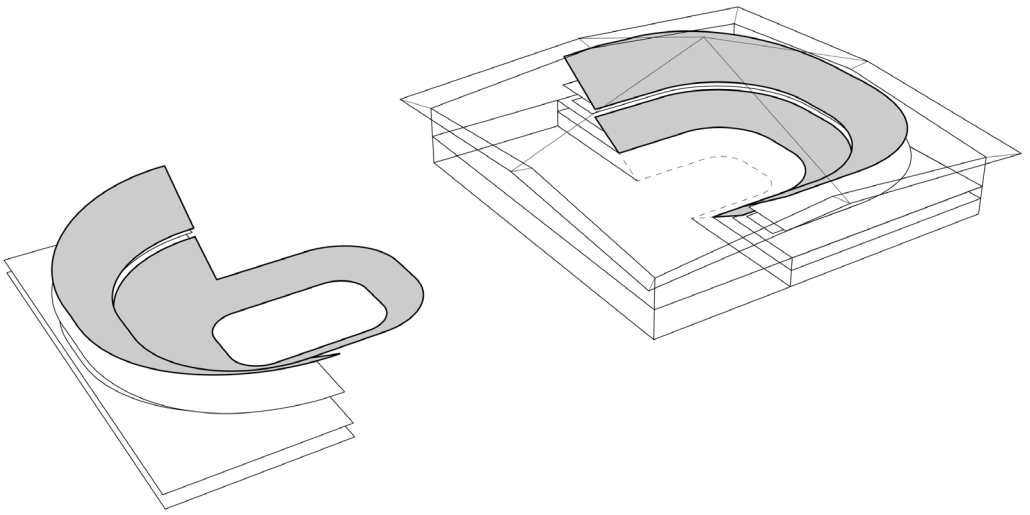

Partial of the old seating bowl will be demolished, leaving space for newly-inserted elements.

## PHASE 2: LINK LIGHT RAIL STATION

In the second phase, an underground light rail station is created 22' beneath the existing lowest level. This station will be the Seattle Center station as a part of the Sound Transit 3 Ballard line. By adding a light rail station directly underneath KeyArena, the building will be activated as a transportation hub, ensuring constant flow of people to the inside of the building itself as well as to the surrounding Seattle Center.

The 400' long station platform, and support spaces such as the station office and storage, stretch south-wards under the existing loading zone south of KeyArena. The two train tunnels run further underneath the existing column foundations of KeyArena, causing little harm to the preserved structure.

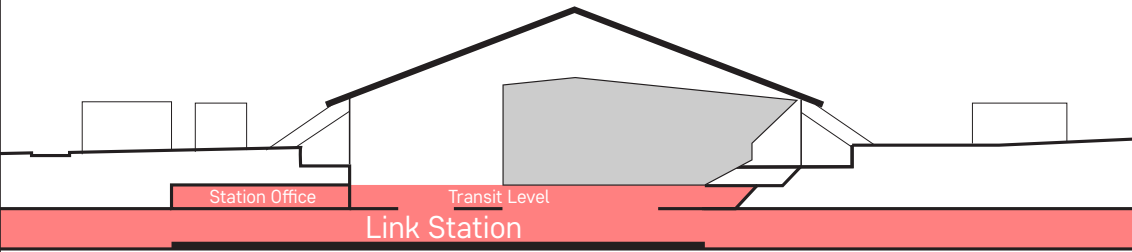
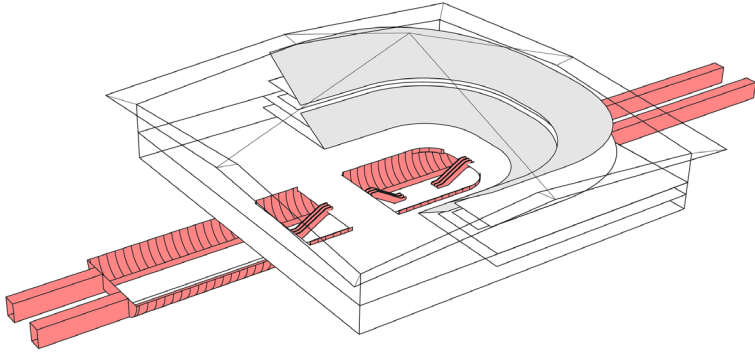

Link station is located right underneath of KeyArena, bring flow of people in and out.

### PHASE 3: NEW SEATING BOWL, INDOOR MARKET

In this phase, new two-tier staggered seating steps are added. It sits at the south side of the preserved old seating bowl. The back of the seating steps are wrapped with transparent "skin" resembling the "jello cake" in the cake metaphor (shown in red).

The space inside of the "skin" is the concourse and catering space with food stalls for events. These food stalls can also be used as a food court during a non-event day to make the most use out of the space.

The nature of the staggered seating steps is that it requires narrower footprint compared to conventional single slope bowl, because the upper terrace is pushed forward. In this way, it allows public indoor market space to be created behind the seating steps (shown in pink). To add vibrancy to the public indoor market, visual and physical connections between the market and light rail station are made possible by having an open gap space in between, which then becomes the main vestibule for light rail circulation.

The other nature of staggered seating steps is that the more forward the seating is, the higher the seating can go due to the upward sloping roof. In this way, the renovation succeeded in maintaining 73.4% of the original area (13,134 seats of the original 17,100 seats), while adding a diversity of new spaces and functions.

The flexible arena space created through the renovation can hold two college basketball courts at the same time, and can be converted into a multifunctional play area for adjacent schools' daily use.

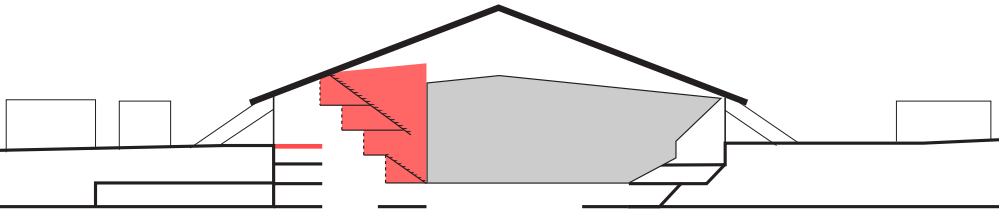
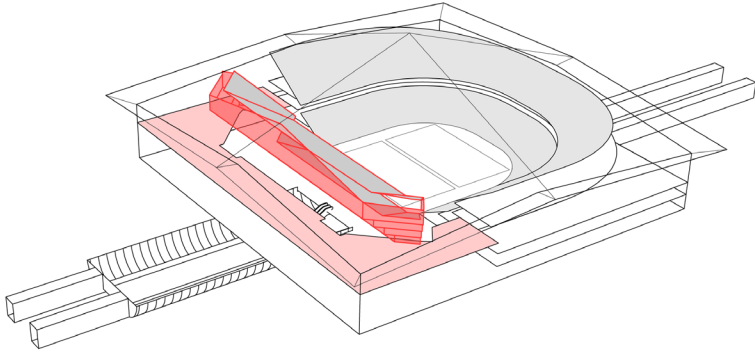

The new staggered seating bowl provides more programs and space for the building.

## PHASE 4: CIRCULATION, GRADING, CURTAIN WALL, ROOF

In this phase, circulation is added to all the "gap" spaces. Two sets of escalators are located in the two gaps between the new and old seating bowls, leading from the station to east and west exits; one set of escalators are located in the gap between the market and the "skin", leading from the station to south market exit; one set of escalators are located under the preserved old seating bowl, leading from the station to north exit.

The south existing loading dock is regarded to the same level to match the indoor market level (shown in pink) to encourage further public entrance from outside.

The original curtain wall system is generally preserved. For the south indoor market part, it is updated to allow more ground level penetration for easy entrances to the building.

Also in this phase, the KeyArena's 1995 renovated rigid roof system is replaced with a catenary ETFE roof, which resembles the original construction of 1962 roof system. The ETFE roof is much more durable and light-weight compared to both the original and existing roof. Therefore, it reduces the load on the existing structure significantly.

By using ETFE roof, it also enables daylight to illuminate the indoor market, as well as the arena floor. In this way, the daytime use of the stadium will require less energy and cost, making it more accessible to frequent community use as sports and event venue.

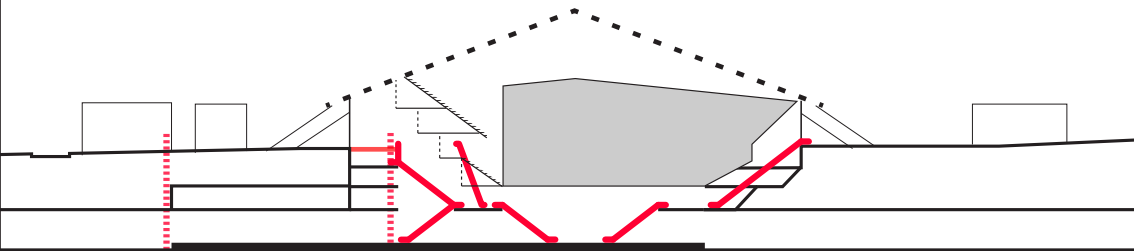
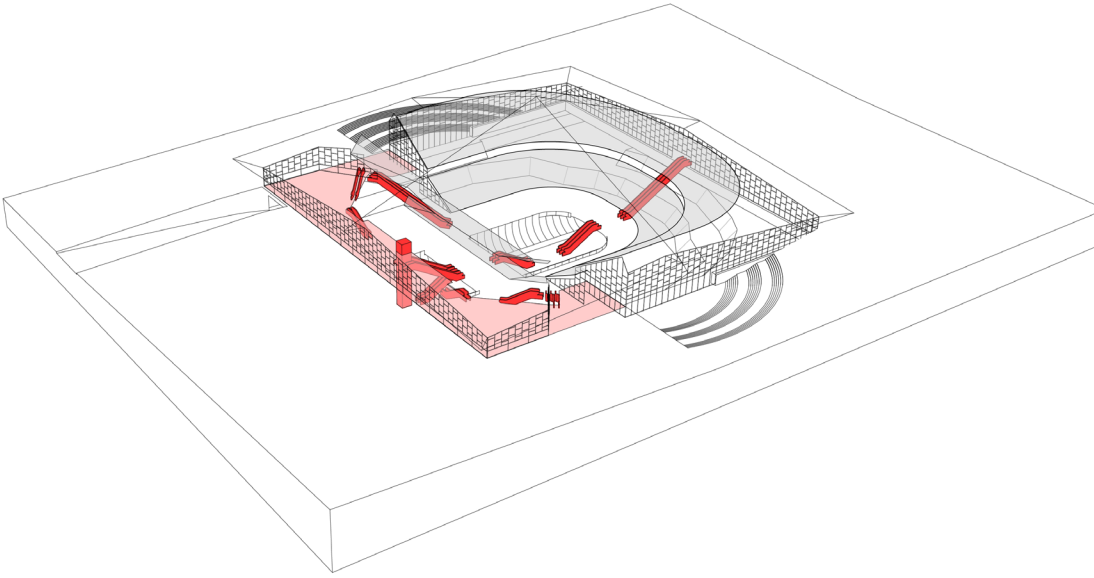

Through floor circulations are like veins of the building, directing people to different levels.

## PHASE 5: SURROUNDING

In this final phase, the existing over-sized empty loading dock, along with several existing buildings that are blocking KeyArena from the south are demolished. In this way, the KeyArena is finally revealing itself to the main axis of the Seattle Center, connecting the dots from Space Needle, Chihuly Garden and Glass, the Armory, Seattle Children's Theatre, Fisher Pavilion, and finally KeyArena.

The existing skatepark to the southeast is preserved, as it anchors the active sports theme for this area. Echoing the sports theme, the site is then retrofitted with open-air basketball courts that are covered by a continuous ETFE roof, making it suitable for outdoor exercise year-round.

The northeast pavilion is also demolished, generously opening the east facade of KeyArena to the International Fountain and Fisher Pavilion garden. The existing north pavilion will be converted into an elementary school. And the south sports canopy is copying the dimension of the north pavilion, responding to the symmetrical composition of the surrounding context.

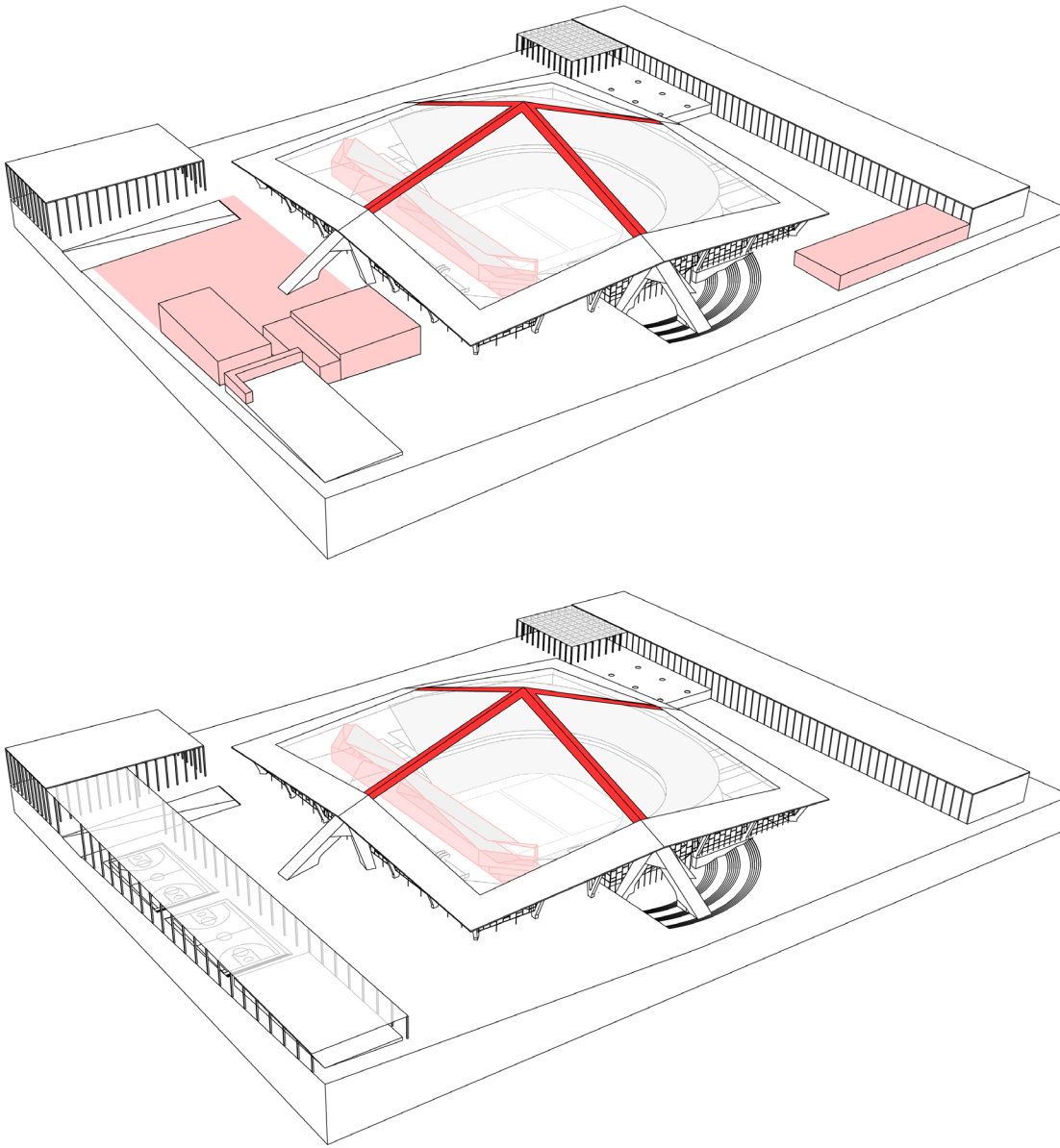

The south loading dock is replaced by covered sports court. The existing north building will be converted into an elementary school.

# 24/7

## COLLAGES OF BUILDING FUNCTIONS

This photo collage shows the longitudinal building section looking west. From the left to the right (the south to the north), space and programs include outdoor covered sports court, weekend farmers market, link station entrance, indoor market, retails, food court, concert/sports arena, link station, practice room, elementary school and playground. It depicts the range of different programs that are integrated in this project and serve diverse functions for people, for the neighborhood and for the city. The 24/7 occupation keeps KeyArena being actively used all the time, in this way the historic building is salvaged and will contribute to people's daily life.

Saturday afternoon basketball, sunny or rainy. Thanks to the canopy covered court.

Love this farmers market. People take link lightrail to visit my fresh produce.

Breakfast after clubbing! How nice! Wow!

Early morning coffee, and boom, I am on the light rail.

"I used to be the world..."

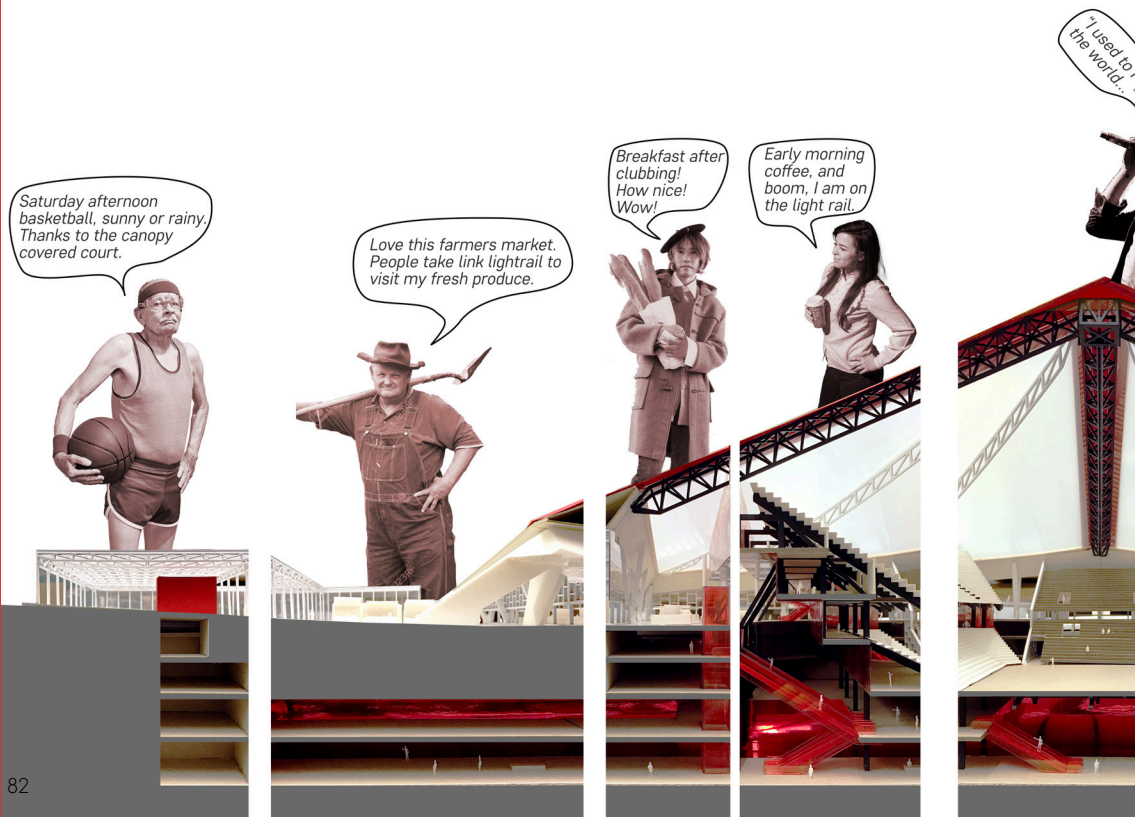



SATURDAY 2:00PM

OUTDOOR COVERED BASKETBALL COURT

*Saturday afternoon  
basketball, sunny or rainy.  
Thanks to the canopy  
covered court.*





SUNDAY 11:00AM

WEEKEND FARMERS MARKET

*Love this farmers market.  
People take link lightrail to  
visit my fresh produce.*



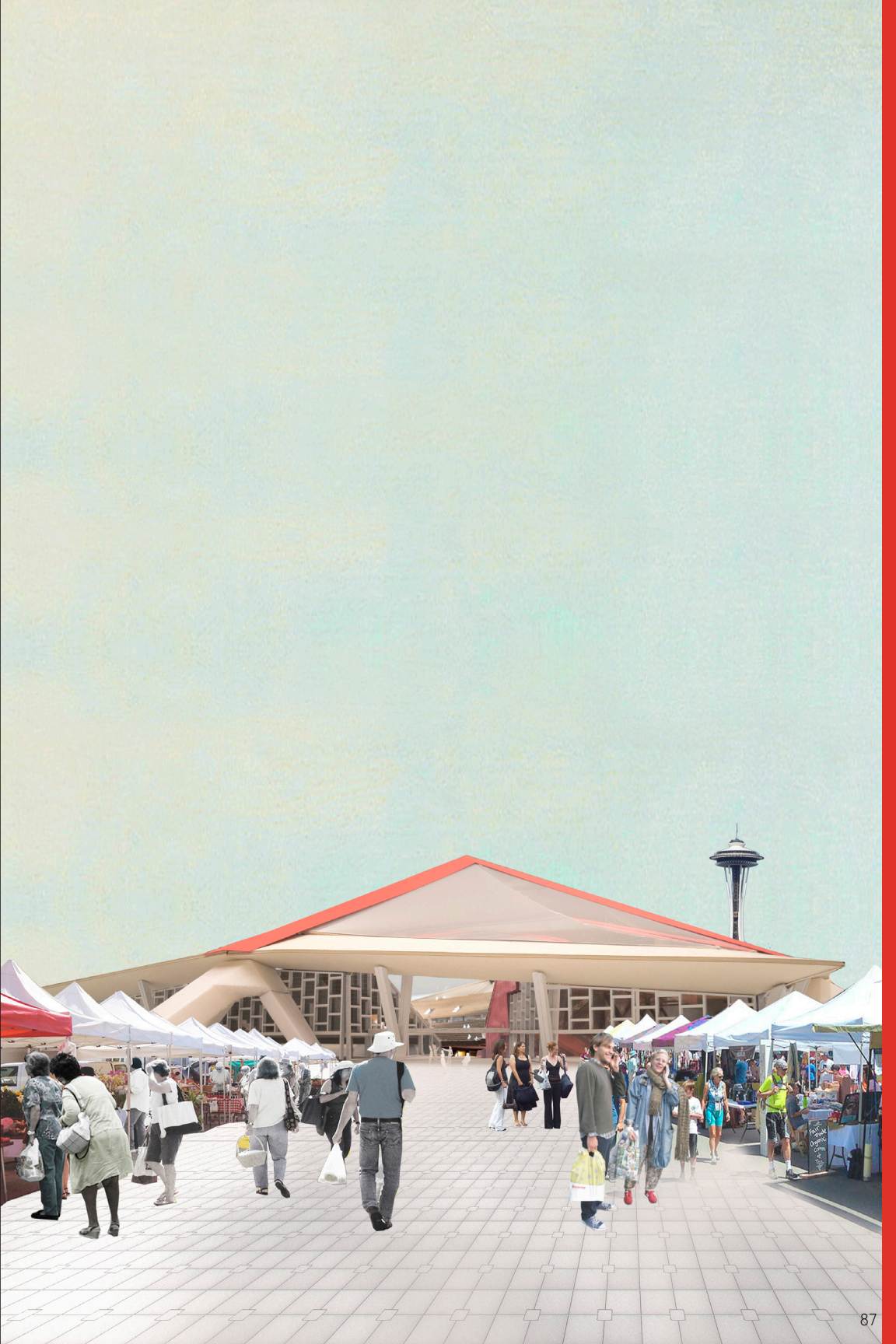

MONDAY 6:00AM

INDOOR MARKET + STATION ENTRANCE

*Breakfast after  
clubbing!  
How nice!  
Wow!*





FROZEN YOGHURT

Amy's

MONDAY 7:00AM

FOOD COURT + LINK STATION

*Early morning  
coffee, and  
boom, I am on  
the light rail.*





TUE 11:00PM

CONCERT + LINK LIGHT RAIL STATION

"I used to rule  
the world..."



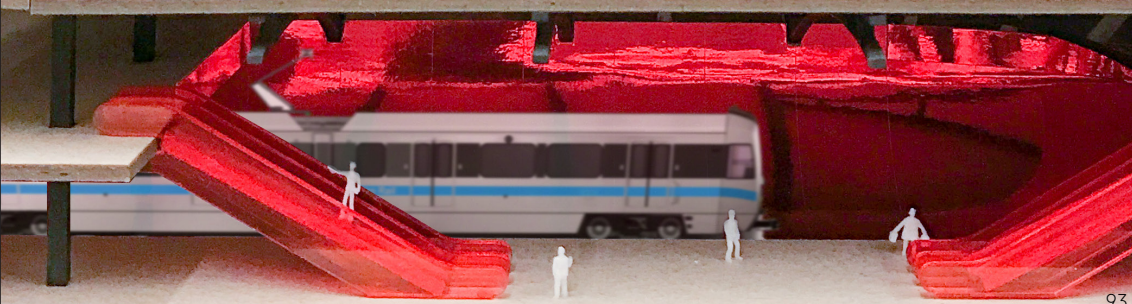

WED 7:00PM

WNBA GAME





Life

KeyBank

38

194

12 4 0 0 0 0

30 0 0 0 0 0

21 0 0 0 0 0

23 1 0 0 0 0

50 1 0 0 0 0

Spartan

SOUTHWEST COOL

THU 8:00AM

ELEMENTARY SCHOOL PLAYGROUND OVER PRACTICE ROOM



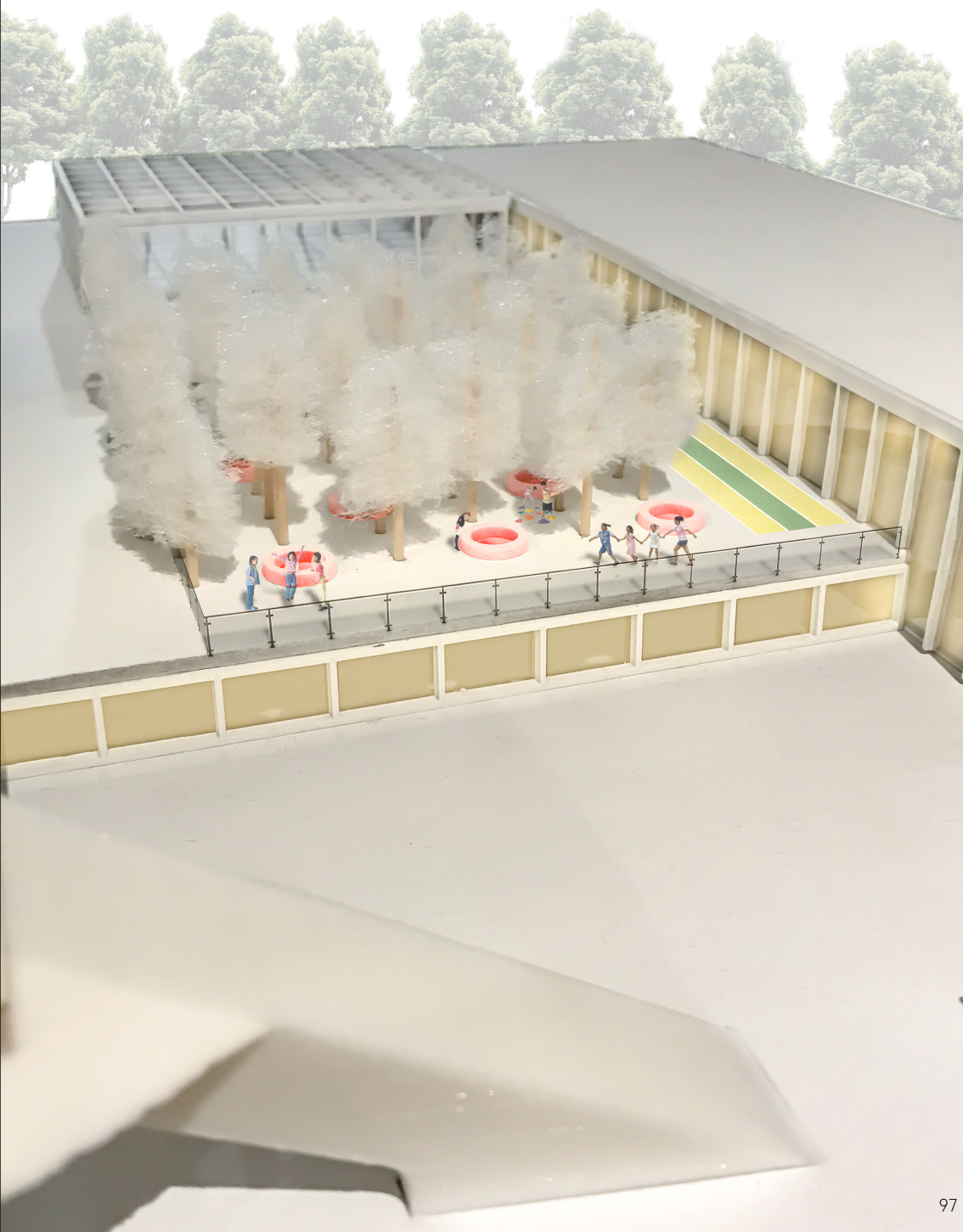

# DRAWING/RENDERING

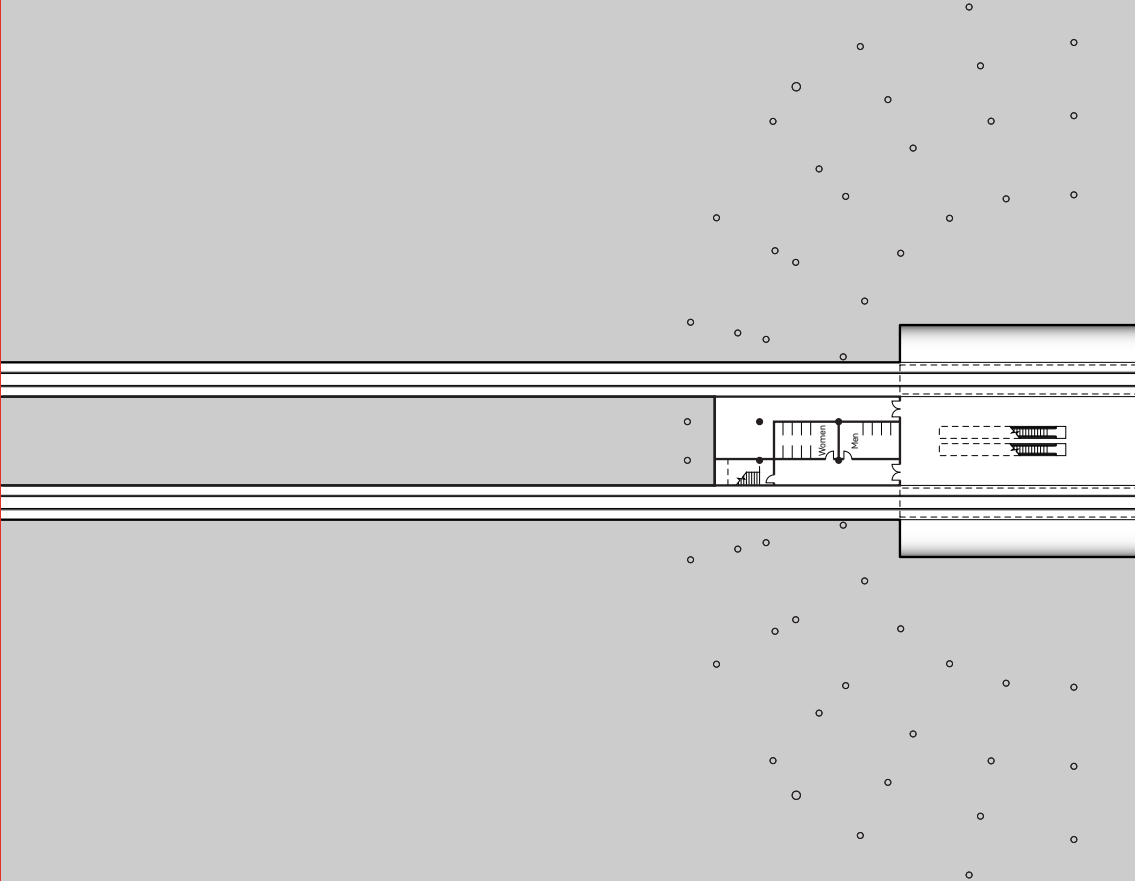

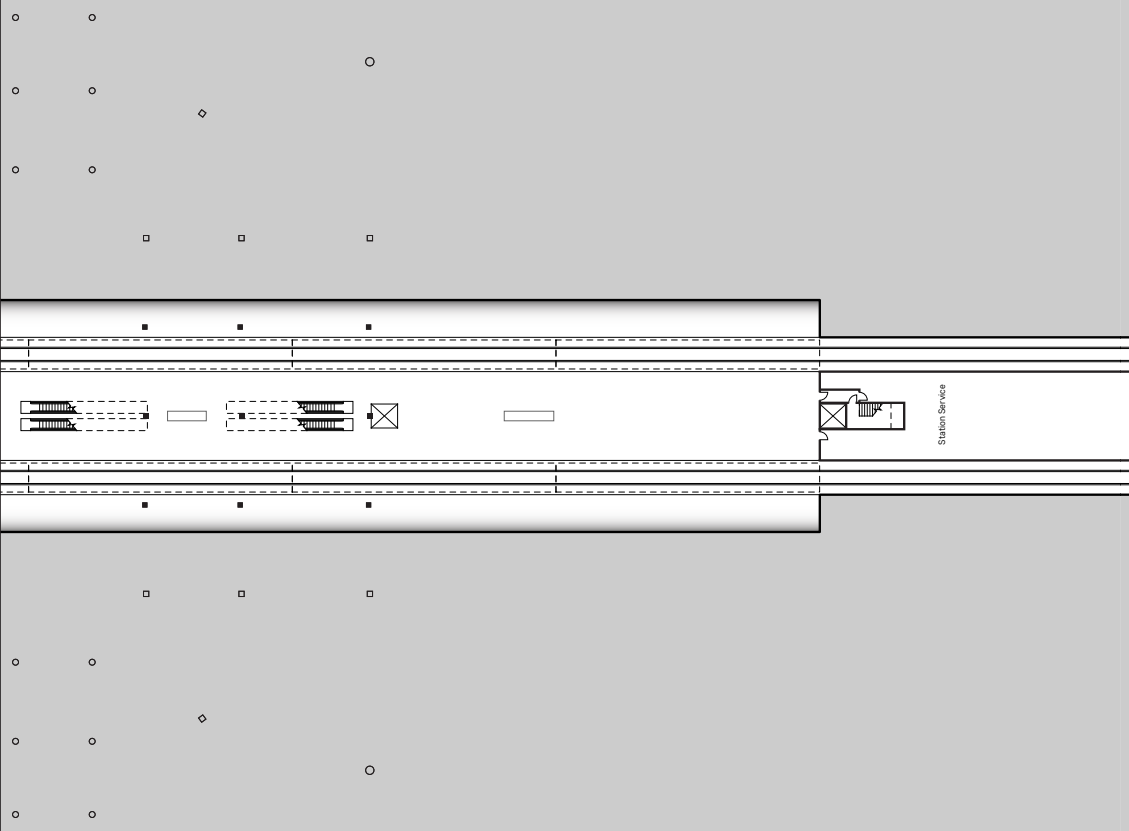

Station Service

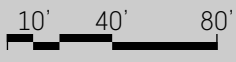

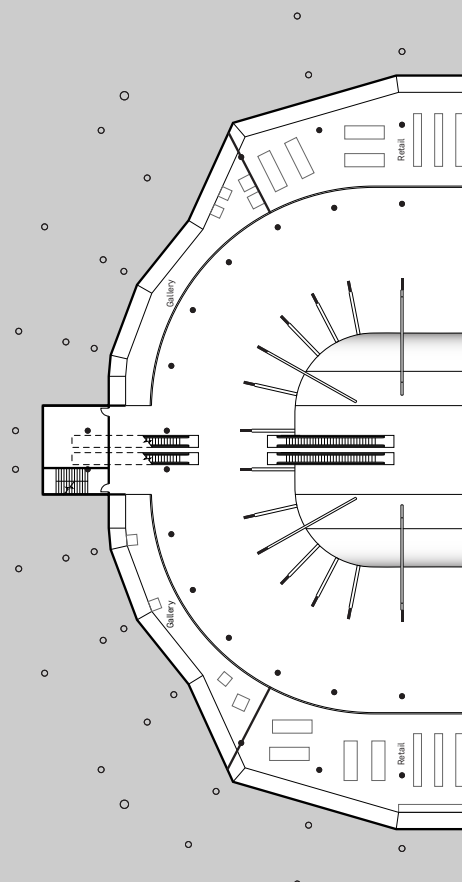

B3 Plan 

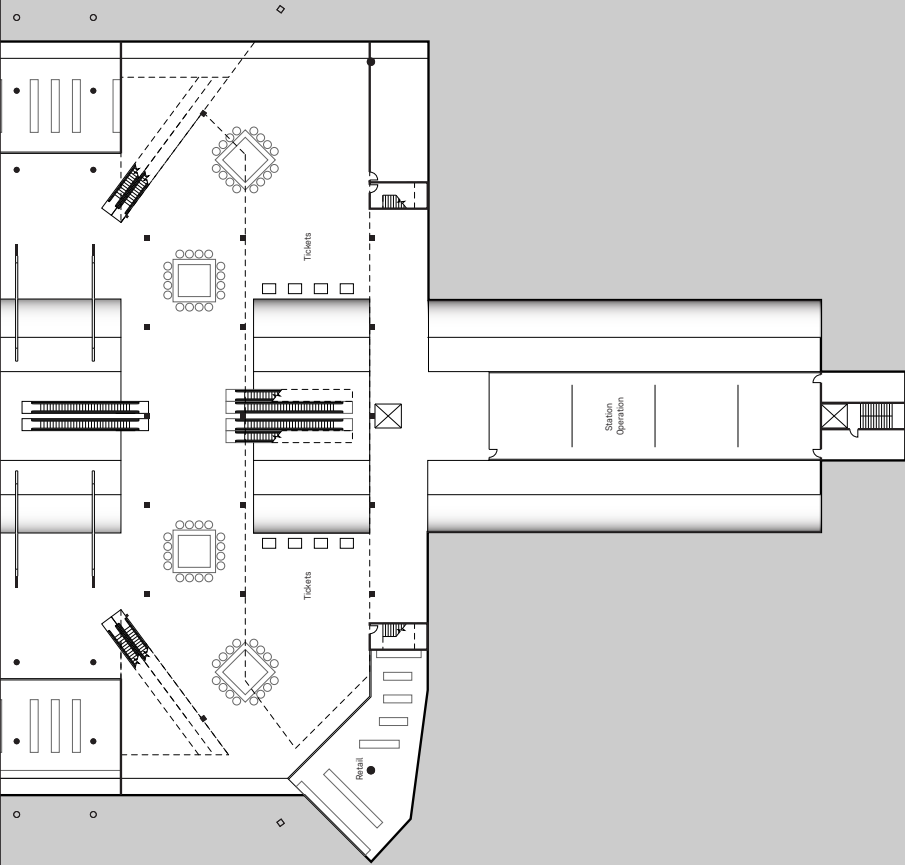

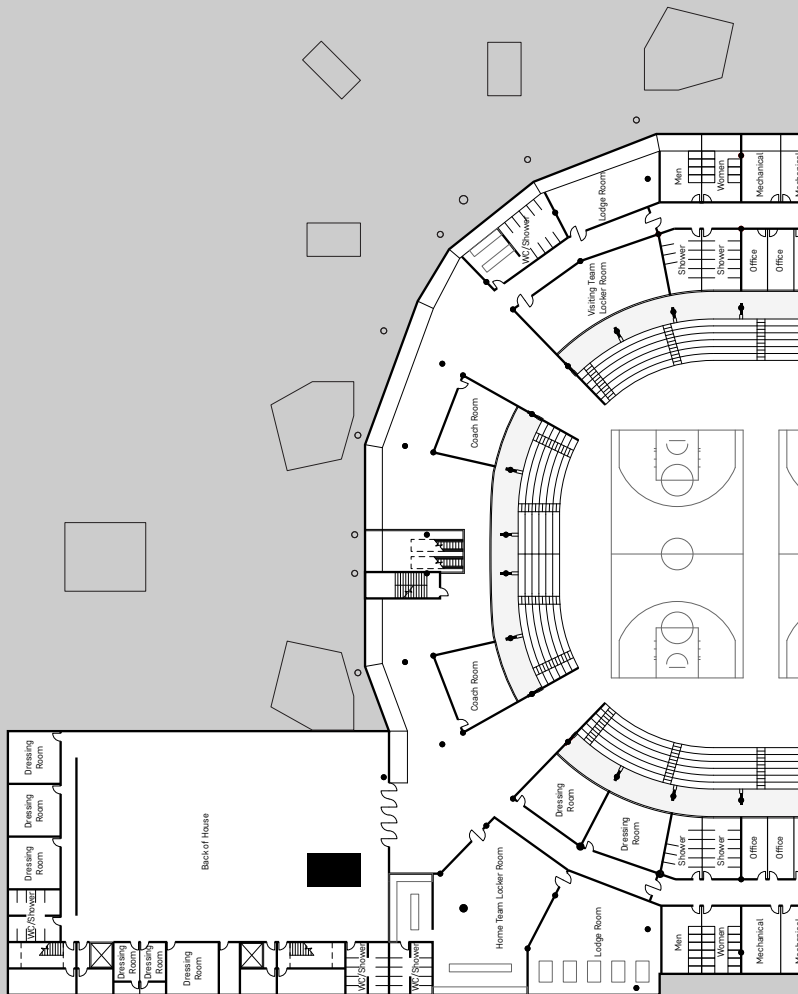

B2 Plan 

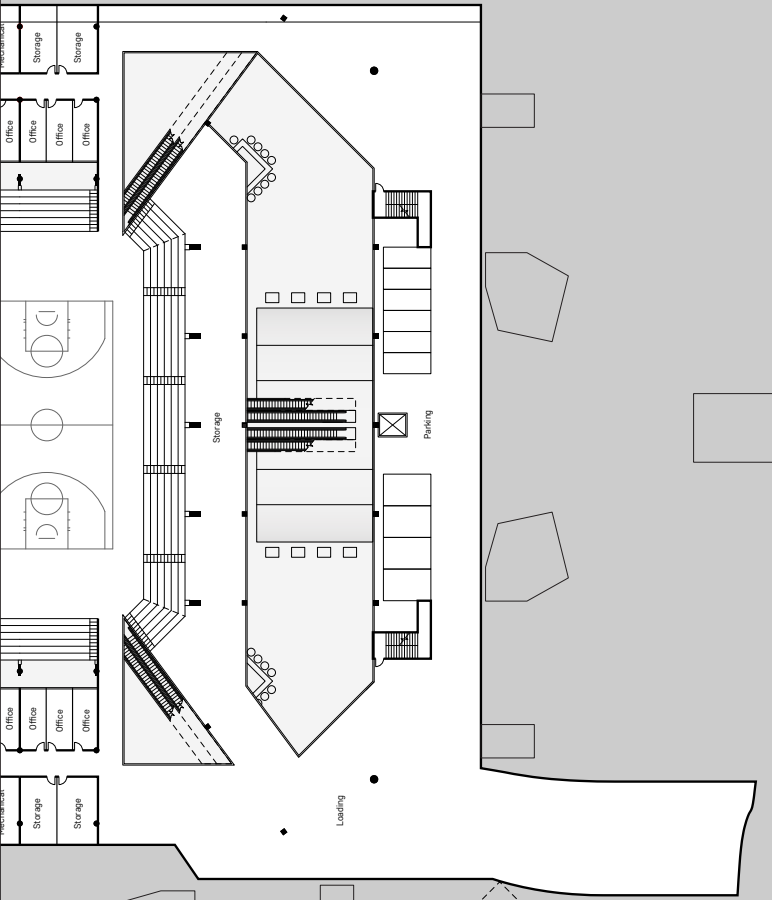

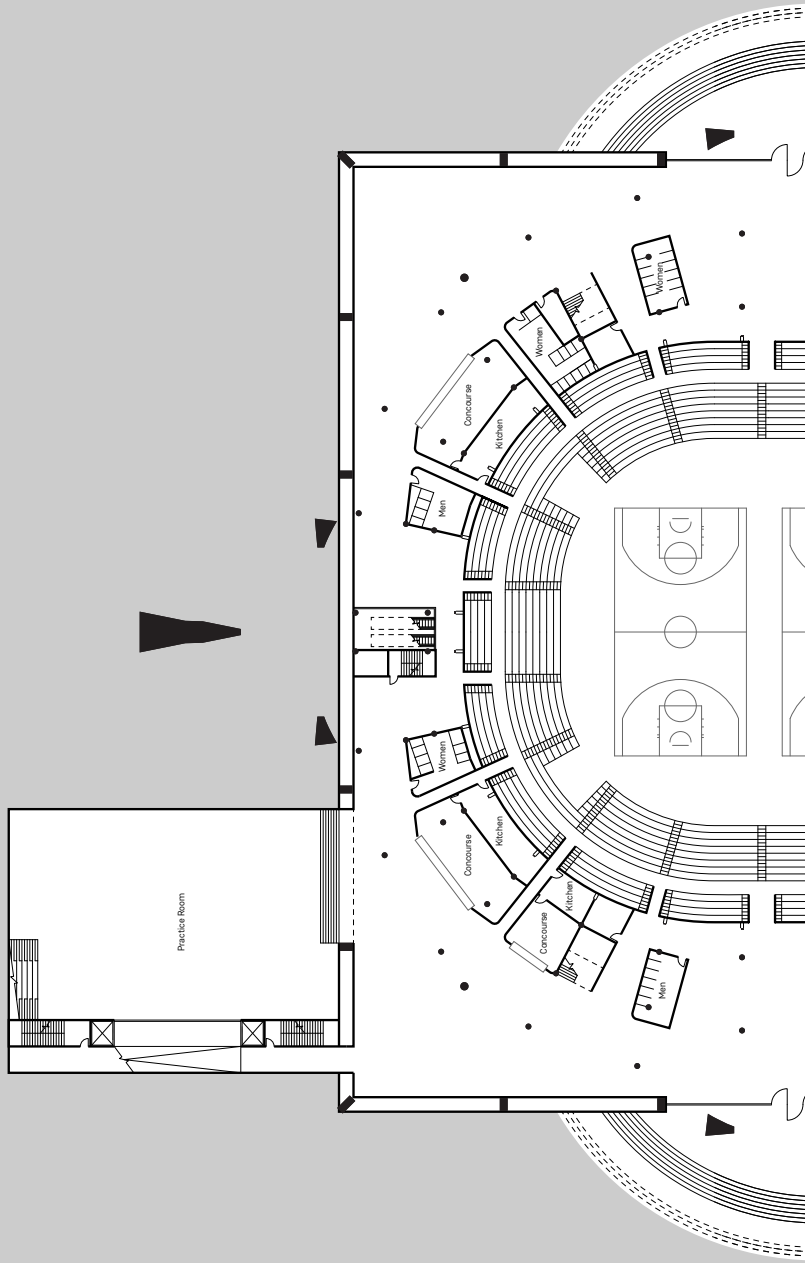

B1 Plan 

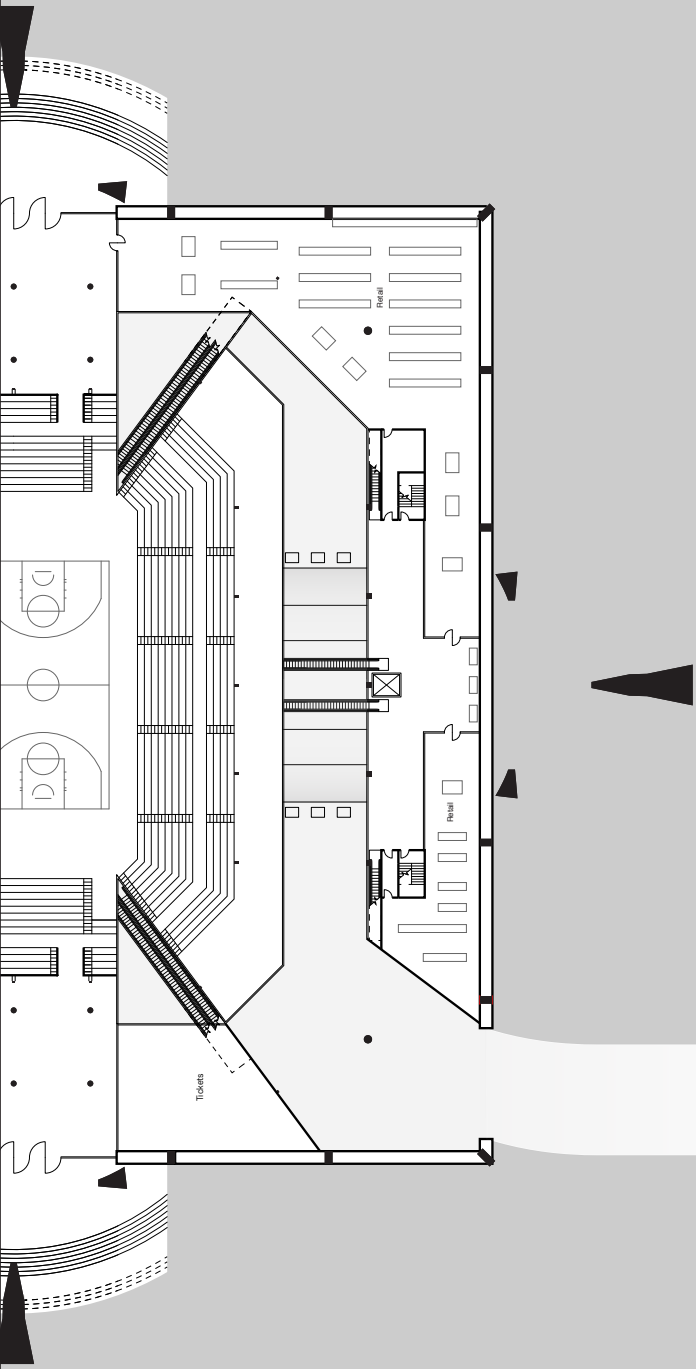

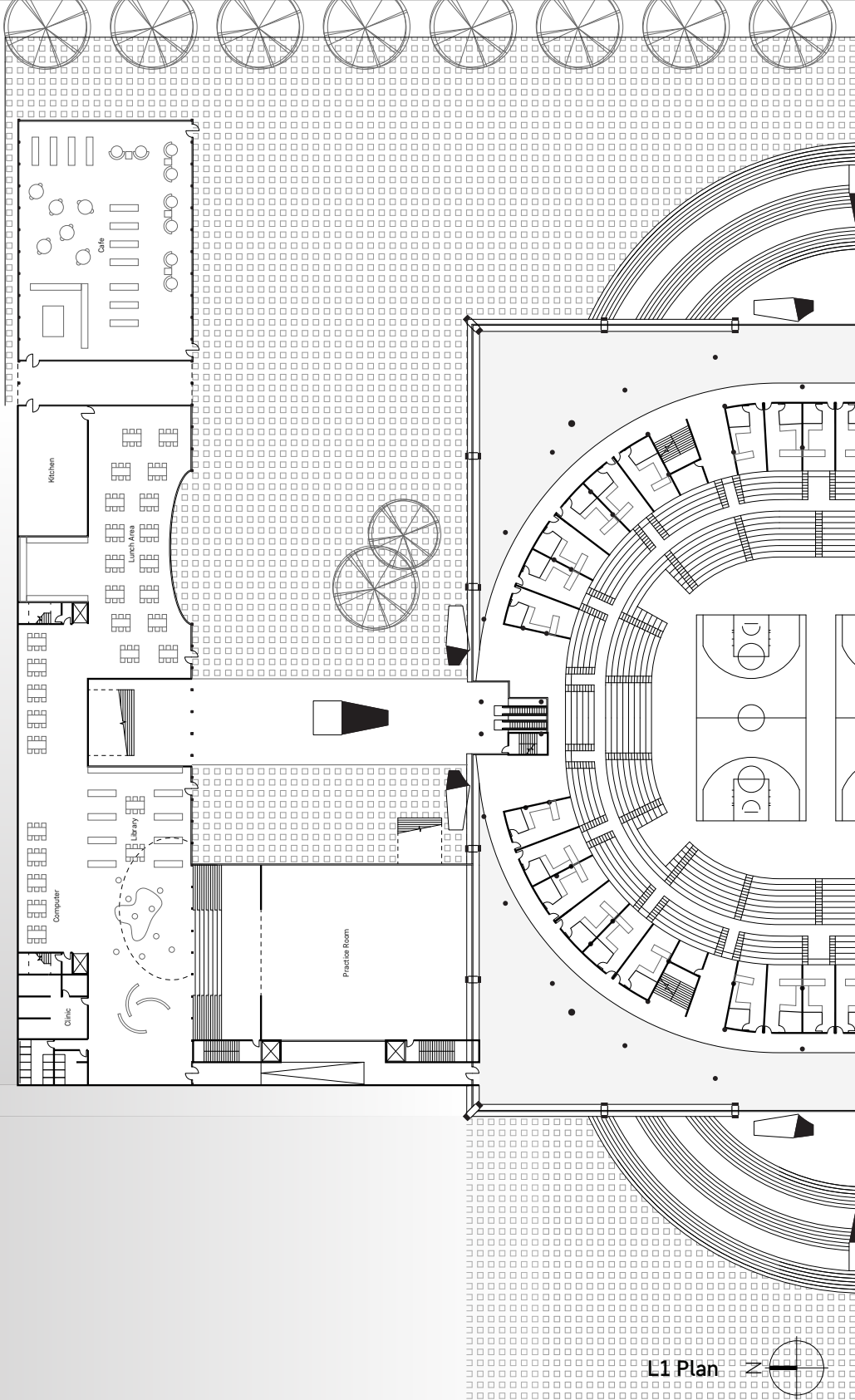

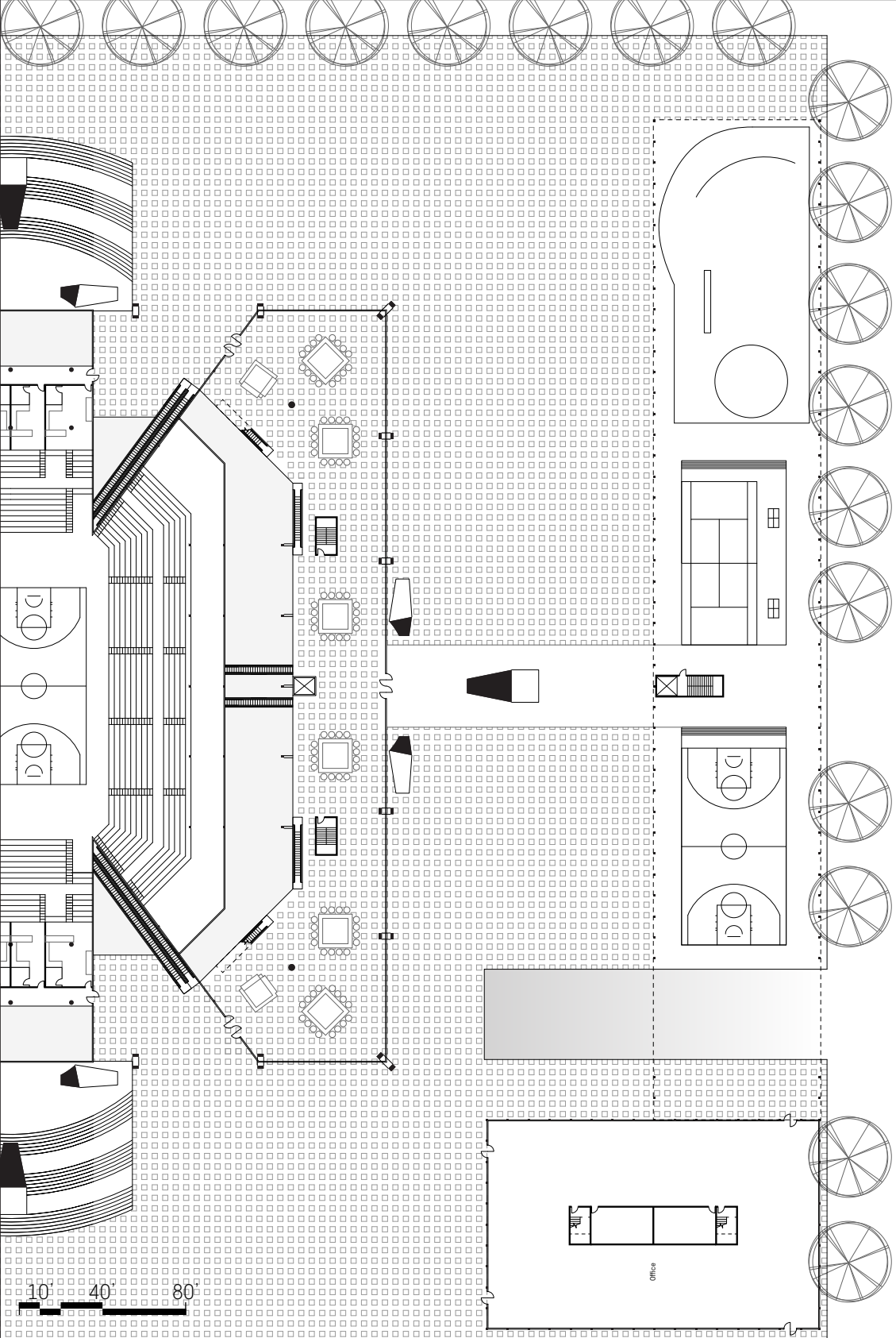

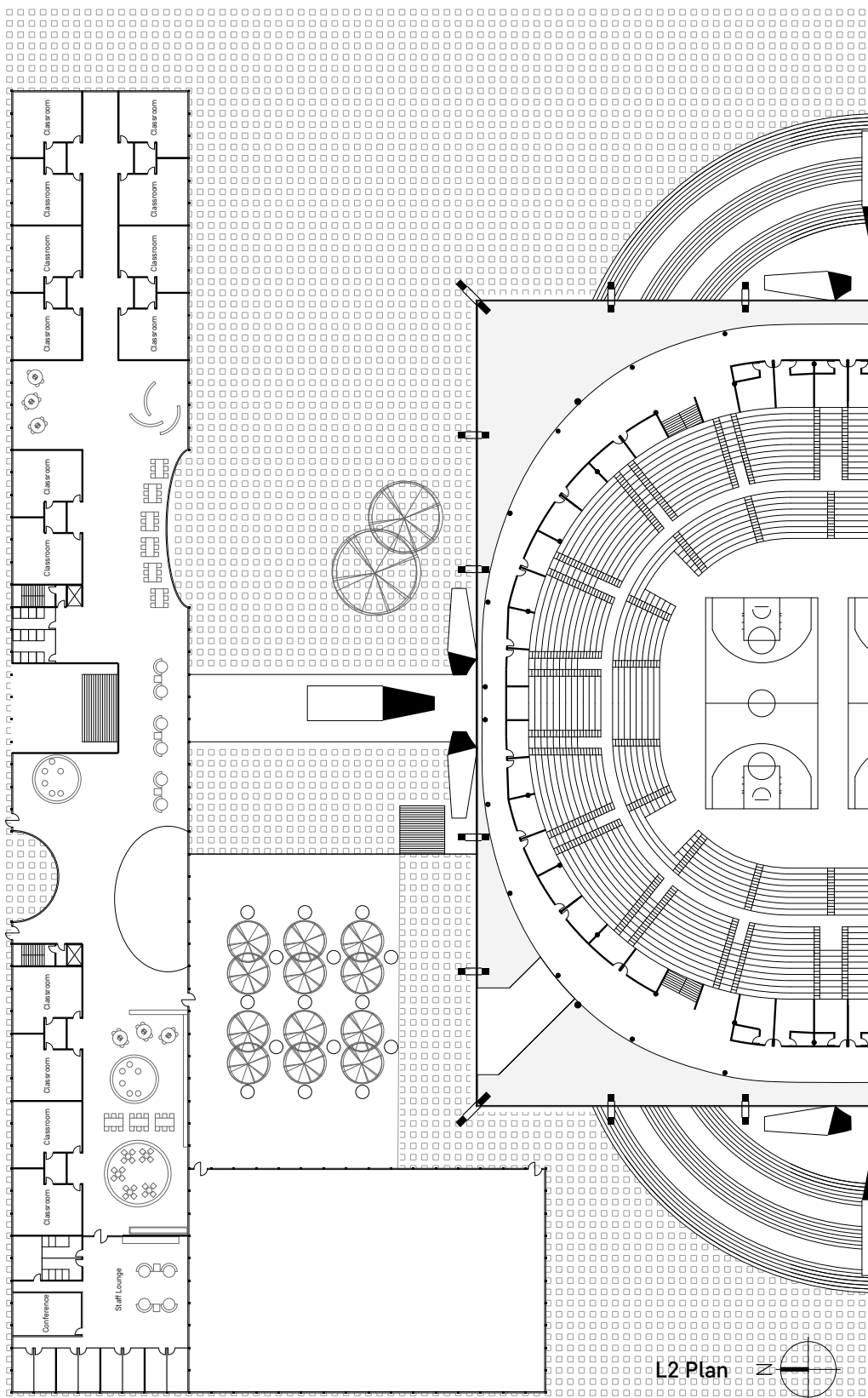

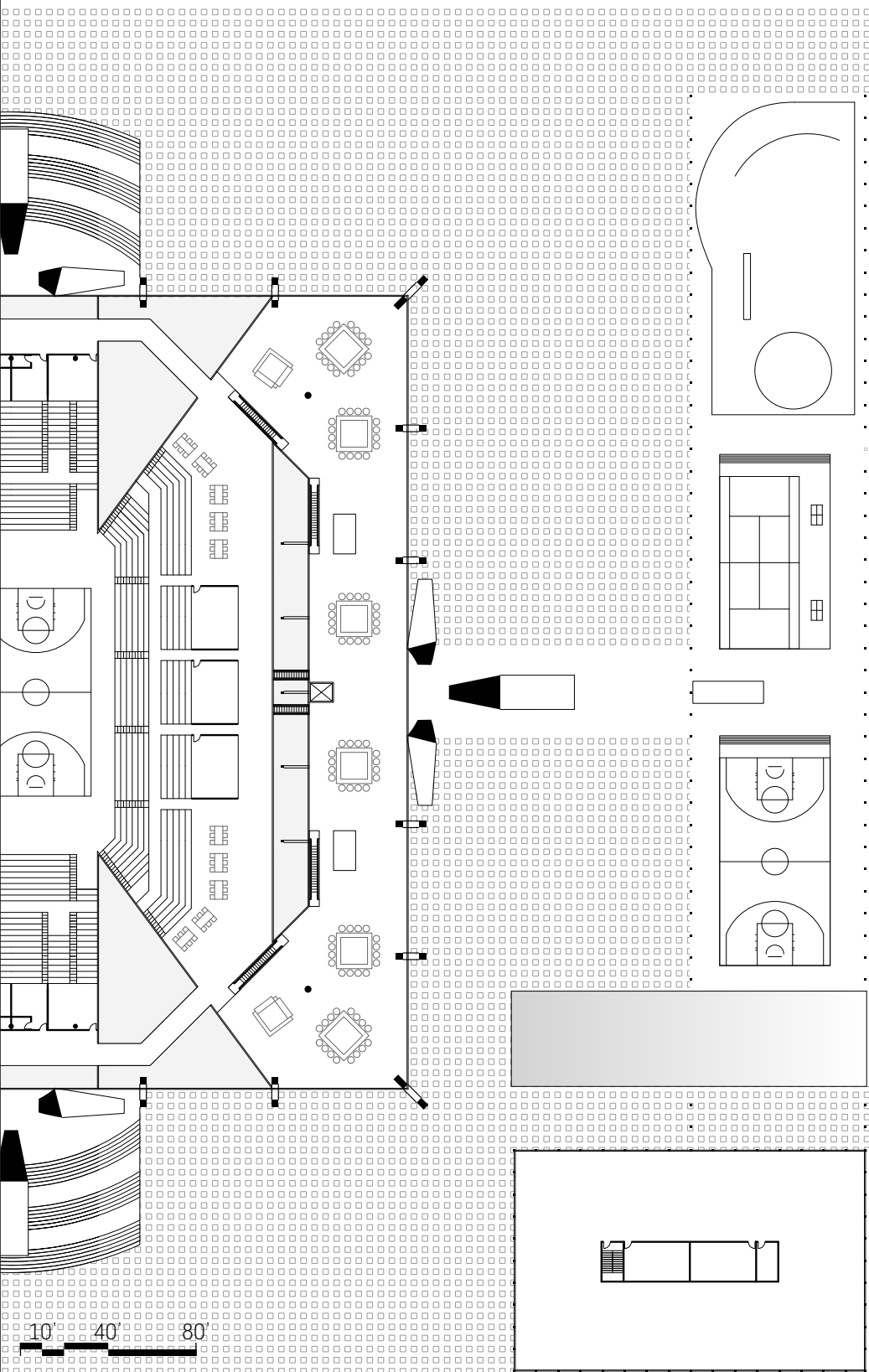

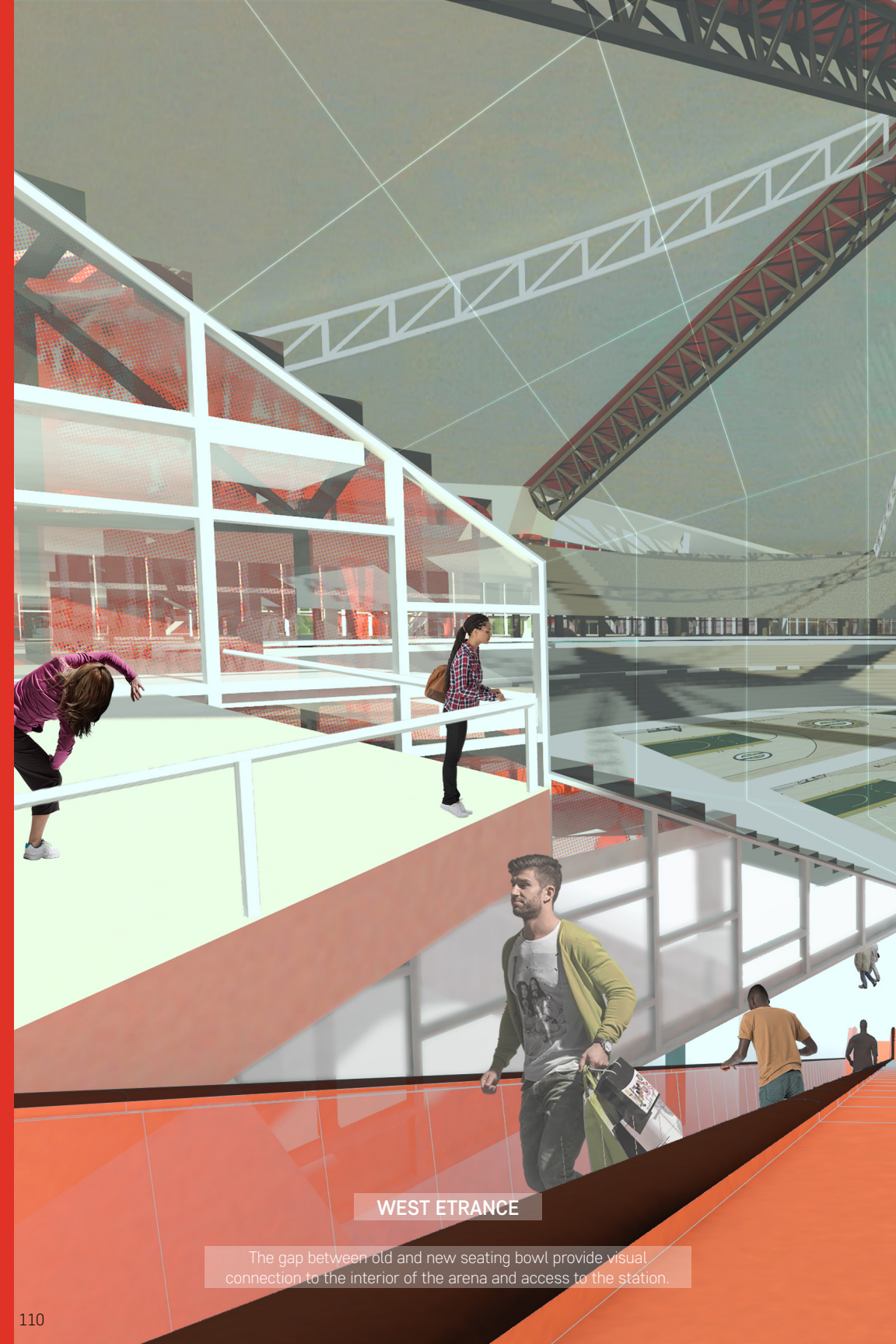

## WEST ENTRANCE

The gap between old and new seating bowl provide visual connection to the interior of the arena and access to the station.

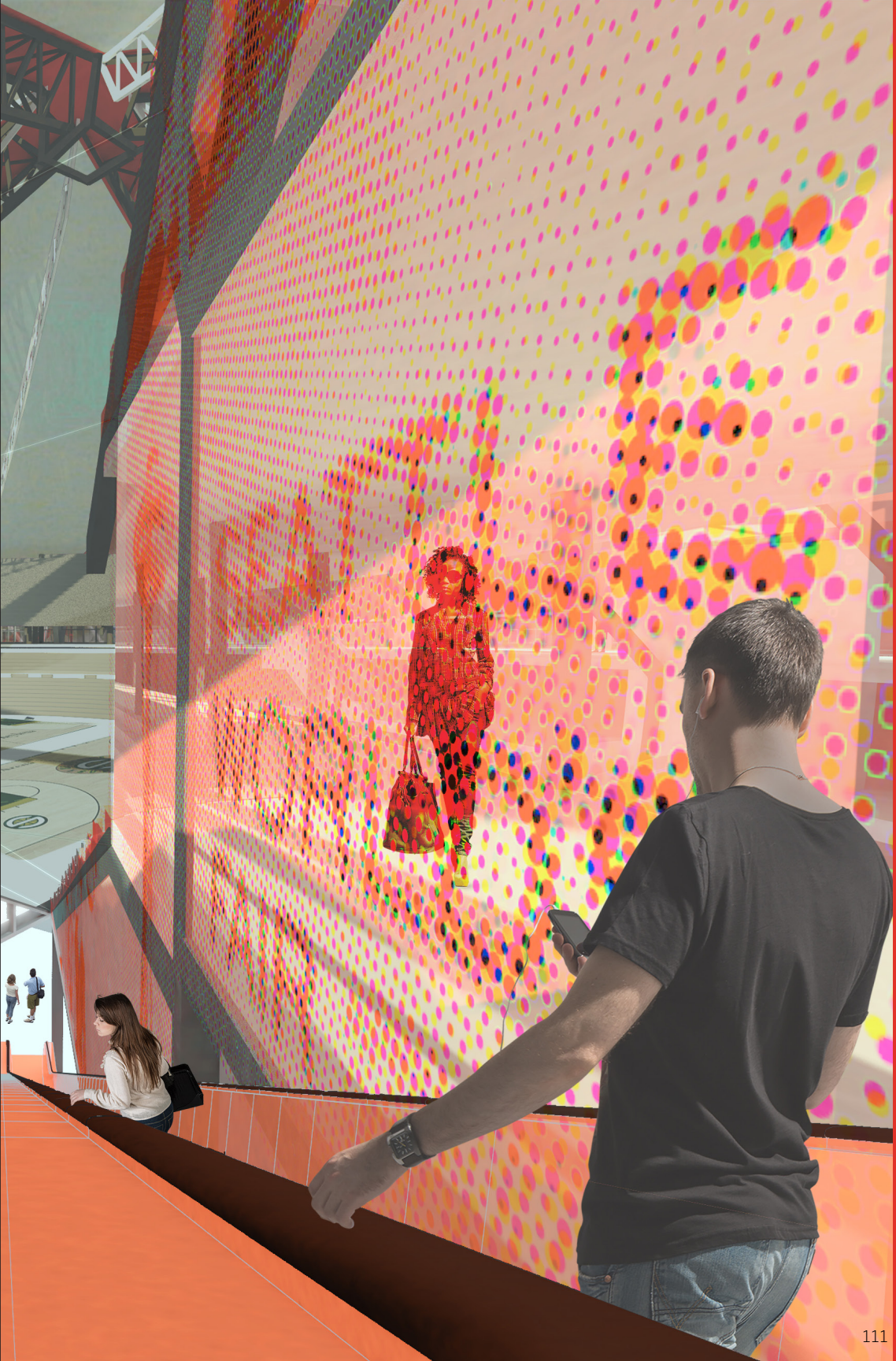



## FOOD COURT

The concourse can be used as food court during time when no event happens



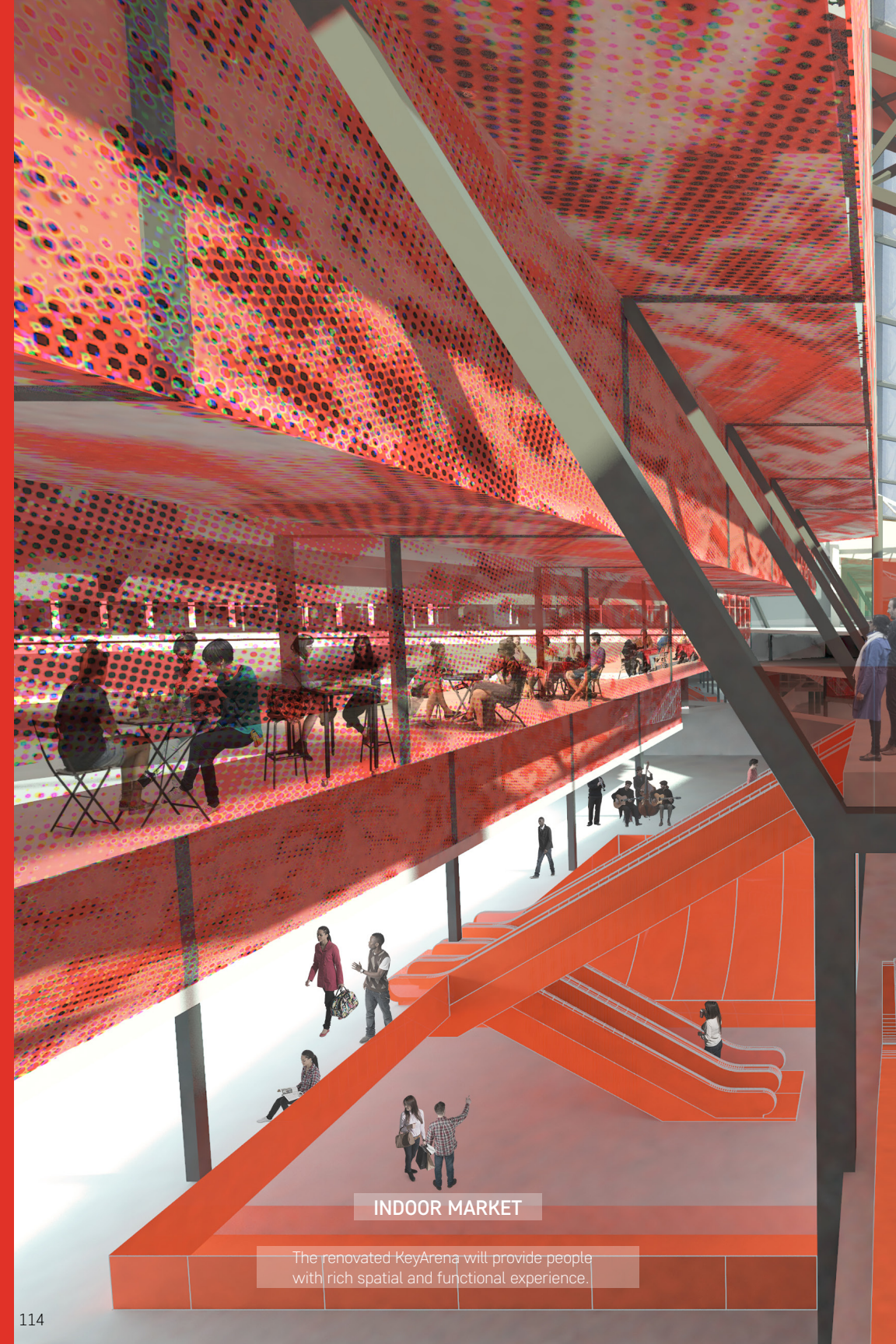

## INDOOR MARKET

The renovated KeyArena will provide people with rich spatial and functional experience.

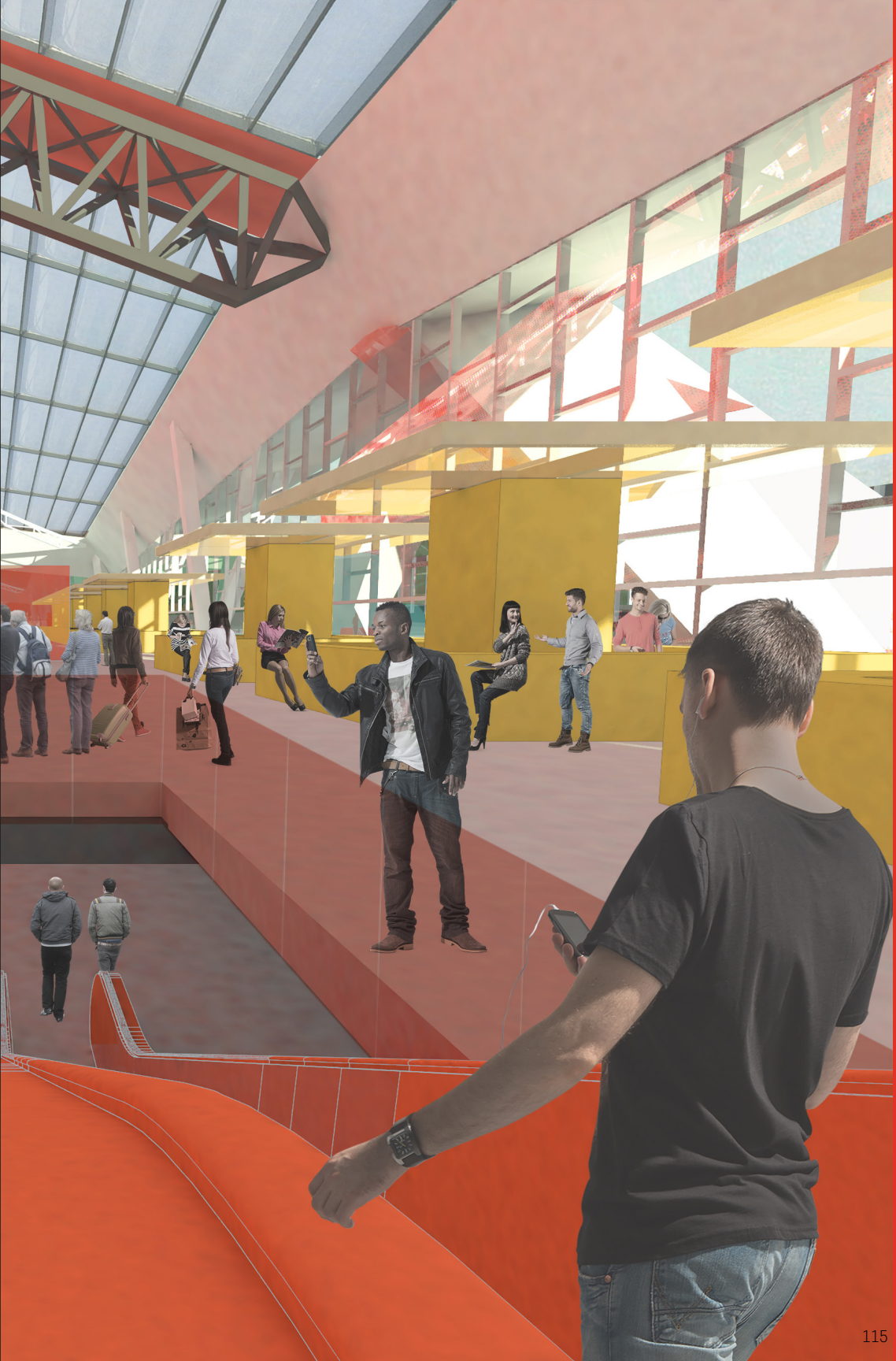



## STATION PLATFORM

The platform and transit level of the link station is beneath the arena courts.





## NORTH ENTRANCE

The north exit of KeyArena is below the three-legged concrete abutment. The elementary school is to its north.



# SUSTAINABILITY

## DAYLIGHTING STRATEGY

The shadow study of KeyArena determined that the north pavilion is not going to be shaded much during school hours even in the winter solstice, thanks to the geometry of KeyArena that is only tall at one point. However, this also means that there will be high chance of direct beam sunlight hitting the north building. To compensate this issue, there will be rows of trees planted south of the building, and trees will be the kinds that lose leaf in the winter.

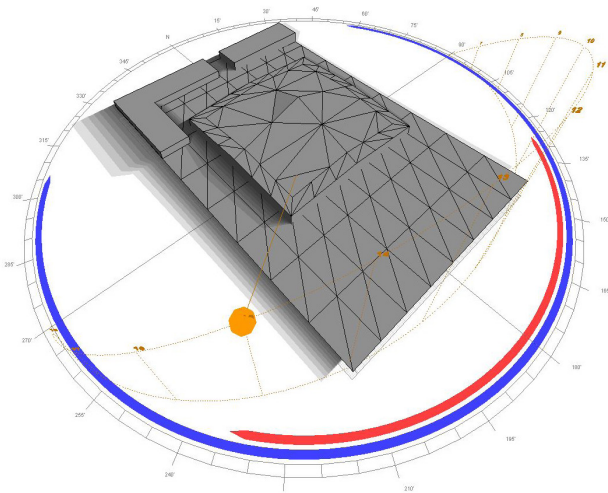

Mar. 21 9:00-15:00

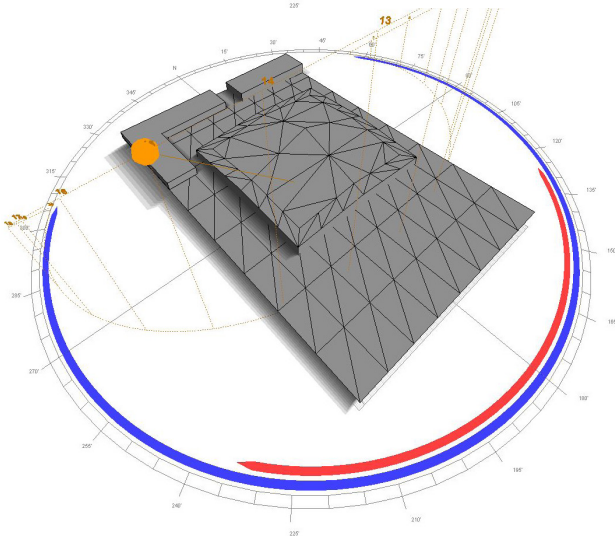

Jun. 21 9:00-15:00

Dec. 21 9:00

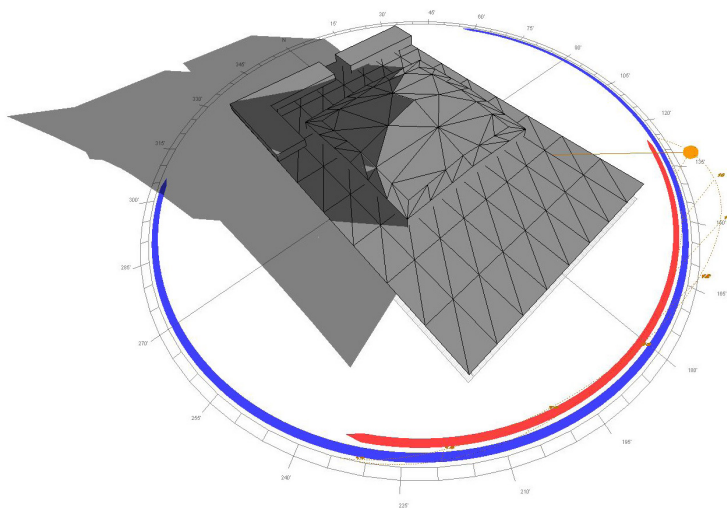

Dec. 21 12:00

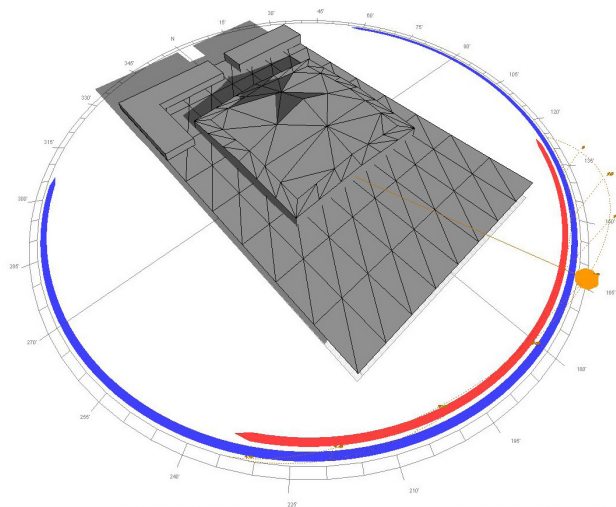

Dec. 21 15:00

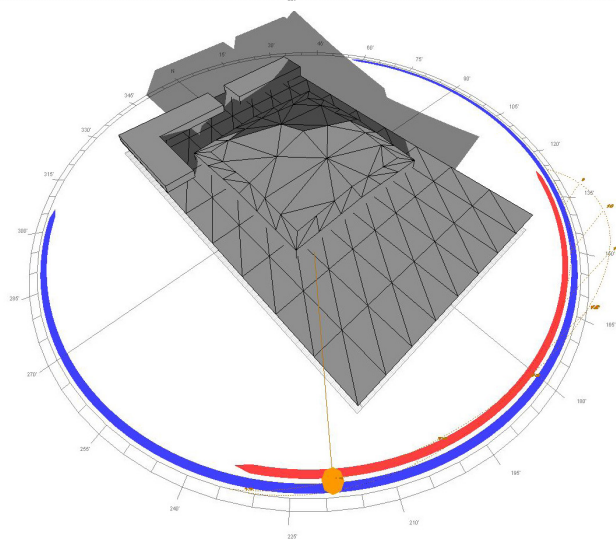

### **KeyArena roof**

The roof for KeyArena will be upgraded to translucent ETFE material, which will bring light down to the inside, enabling daytime arena use without electrically lighting the space. High opacity retractable roof shades will also be installed under the ETFE roof to be activated in case the arena needs to be dark during daytime.

### **Outdoor playground**

The south side of new KeyArena will host informal outdoor playground and sport field that is covered by ETFE roof and a row of existing trees will shade direct beam sunlight

### **Public indoor market**

The south end of new KeyArena in this thesis will be programmed as a public indoor market, for its access to ample of natural daylight from the south.

### **IESNA Criteria**

Basketball Gymnasium:

1000lx Horizontal illuminance

300lx Vertical illuminance

Glare control / Shadow control

Shopping mall Kiosks:

1000lx Horizontal illuminance

300lx Vertical illuminance

Example of ETFE Gymnasium



Example of indoor market



IESNA Lighting Design Guide

Interior

INTERIOR LOCATIONS AND TASKS	Very Important	Important	Somewhat important	Blank = Not important or not applicable
<b>Design Issues</b>				
Appearance of Space and Luminaires				
Color Appearance (and Color Contrast)				
Daylighting Integration and Control				
Direct Glare				
Flicker (and Strobe)				
Light Distribution on Surfaces				
Light Distribution on Task Plane (Uniformity)				
Luminances of Room Surfaces				
Modeling of Faces or Objects				
Point(s) of Interest				
Reflected Glare				
Shadows				
Source/Task/Eye Geometry				
Sparkle/Desirable Reflected Highlights				
Surface Characteristics				
System Control and Flexibility				
Special Considerations				
Notes on Special Considerations				
Illuminance (Horizontal)				
Category or Value (lux)		F		
Illuminance (Vertical)				
Category or Value (lux)				D
Notes on Illuminance - see end of section				D
Reference Chapter(s)				
Basketball				
Kiosks				(9)

## Lighting design as a guidance to program organization

The position of light sensitive programs such as basketball court, market, and school are placed at optimized location for daylight.

## Paring illuminance need

Since both basketball court and market kiosk share the same 1000lx horizontal illuminance criteria, they are perfect to be paired together under the same ETFE roof.

## DIVA Analysis

Nodes setting: 2.5ft above floor level

ETFE Material: DIVA default Translucent 20

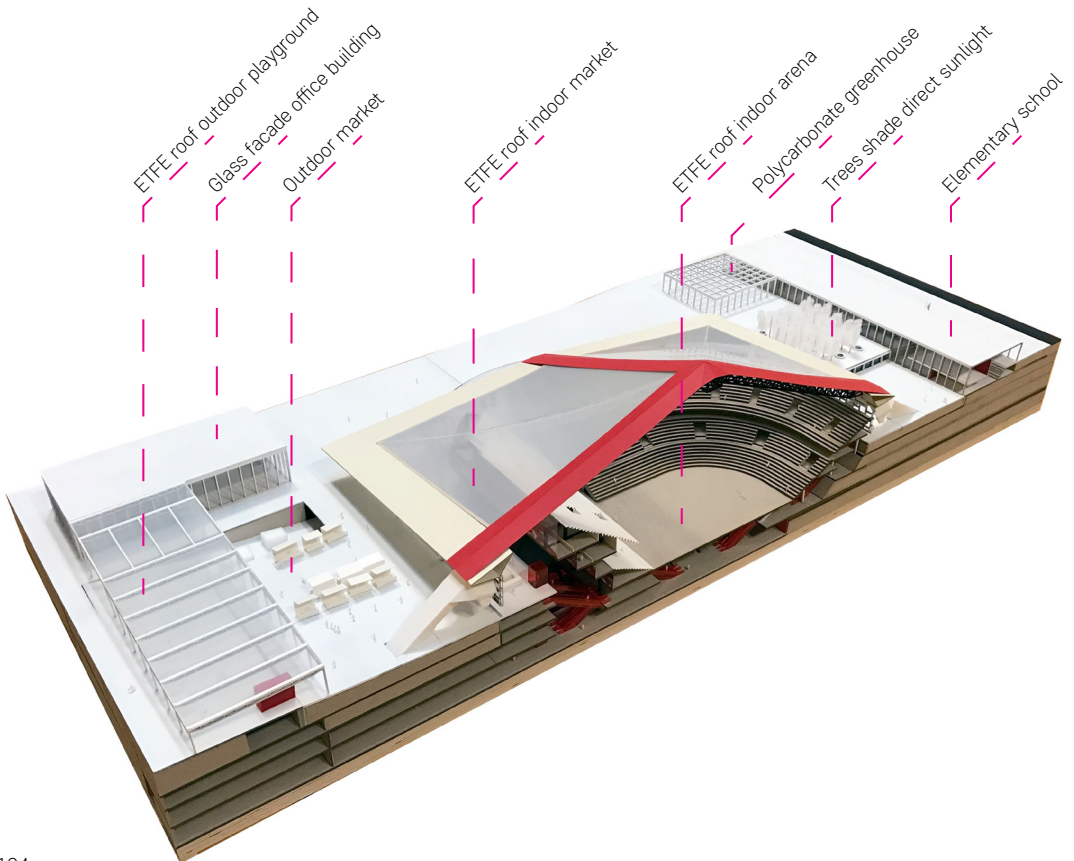

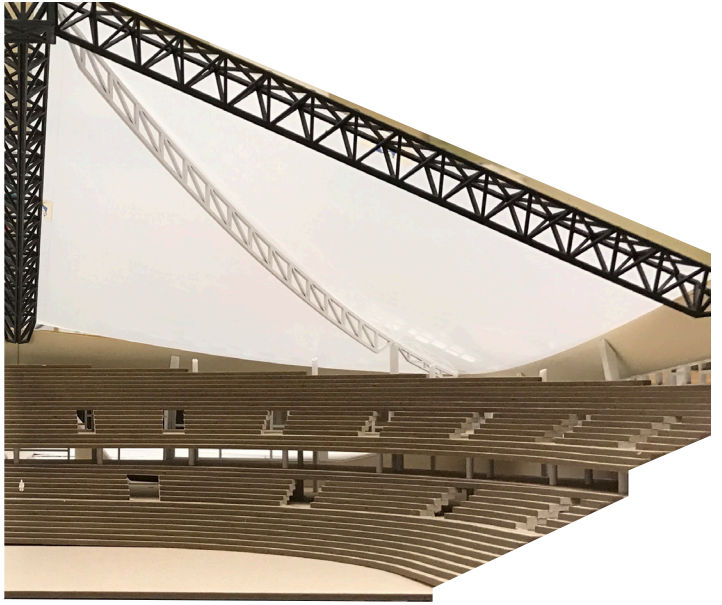

Basketball Court

1000lx illuminance

Market Kiosk

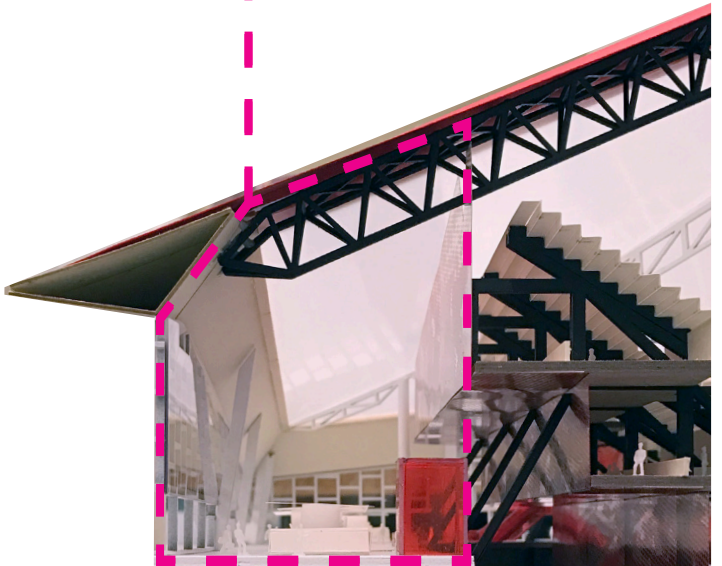

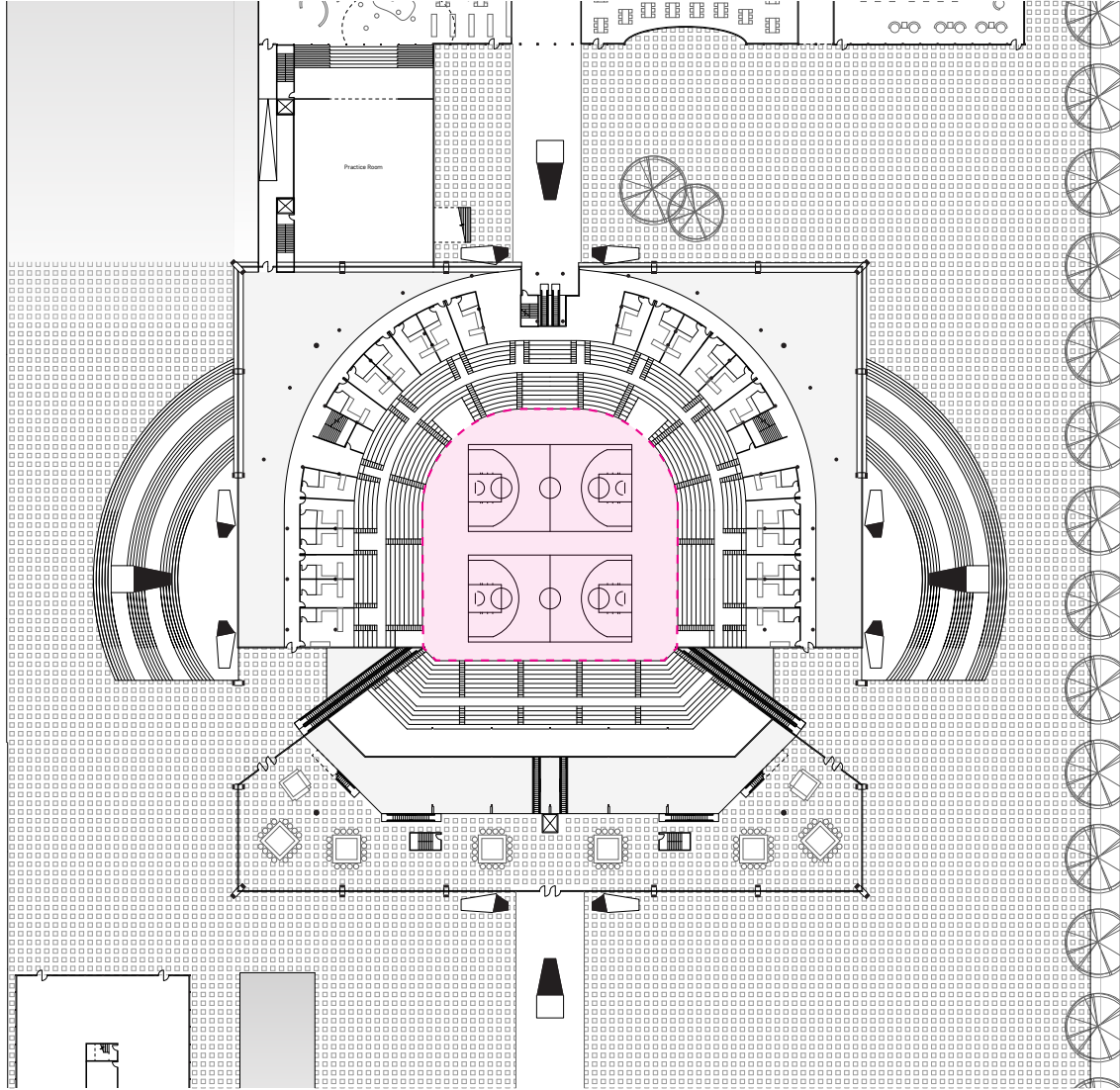

Dec. 21 12:00 Overcast Sky | Basketball Court

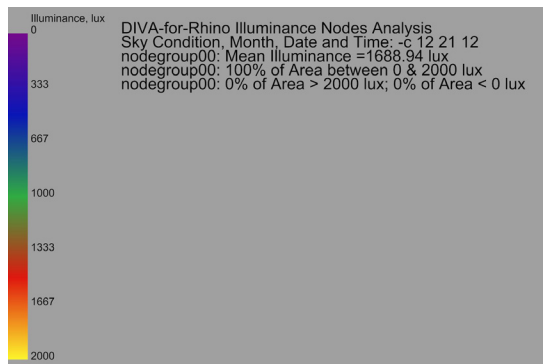
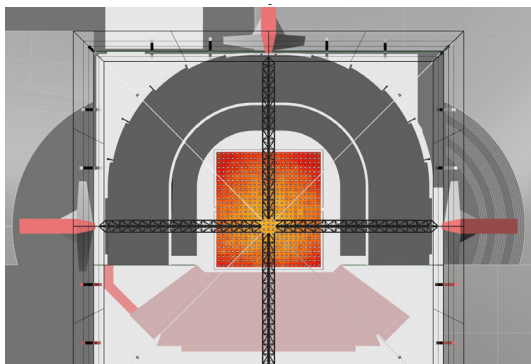

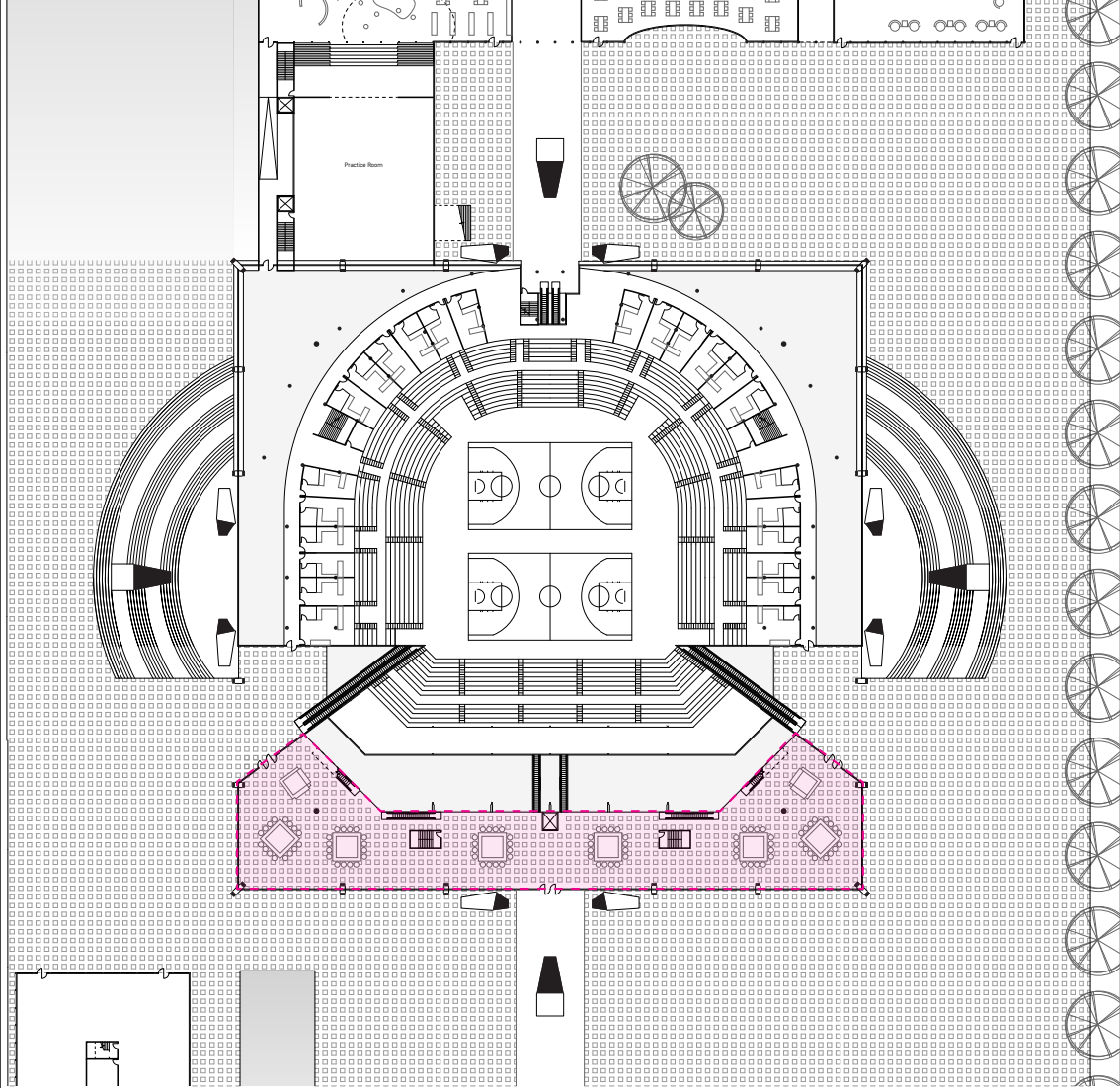

Dec. 21 12:00 Overcast Sky | Market Kiosks

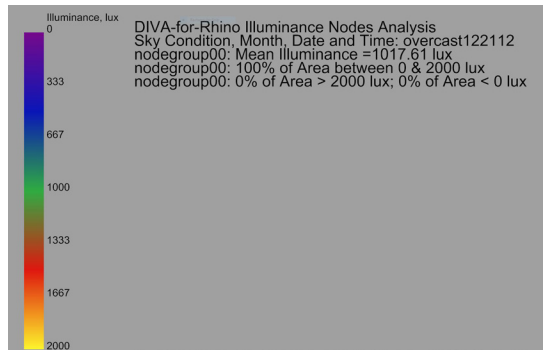
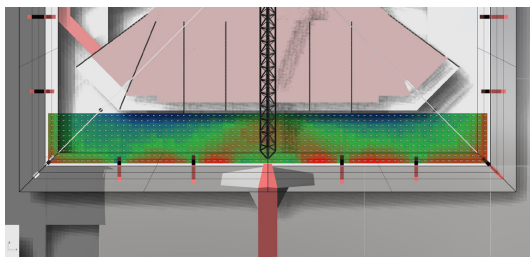

The illuminance value for the market at noon in an overcast winter solstice is averaging at exactly 1000lx. This is exactly what is anticipated. However, the illuminance value for the basketball field is averaging at around 1700lx, which is higher than desired. Especially if in a clear day of summer, the value will be much more than needed. Therefore, retractable high opacity roof curtain is definitely necessary in the arena part. Also, the choice of type of ETFE can be further studied to effectively reduce the light transmittance value, which will directly reduce illuminance level of the interior.

The new KeyArena is using lighting analysis as a way to organize location of crucial programs. It is particularly important for a public building to not only be energy efficient, but more importantly comfortable in terms of lighting condition. By incorporating new materials like ETFE, which is superior in daytime illumination while avoiding direct beam sunlight, also high in R value to be energy efficient. With all the new energy this new KeyArena will have, hopefully this will transform the old Witness to be the center of local Nownness.



# **Chapter 5: Conclusion**

This thesis started with our curiosity in the mysterious KeyArena. After researching on its background, we understood that its mystery lies in its rich time layers as the witness of the history, the link between now and the past. Having been there for more than half a century, KeyArena is not only a masterpiece of architecture but also a local witness, watching the young gets old, the city gets matured. If a person is the accumulation of his/her past, then a city is made up of tangible and intangible pieces that cumulatively form something called history. For a historic landmark building like KeyArena, who contributed deeply in Seattle's history, the value of preservation lies in its significance for local identity and life, and in its homage to earlier mentalities and cultures.

However, as society progresses, culture evolves, and technology develops, the ever-changing context is pushing people's life and culture forward. Simply physically preserving a historic building cannot prevent it from becoming outdated and obsolete, causing it to be a left-behind, rather than protected and appreciated. Preservation, therefore, shouldn't mean stereotype superficial conservation that addresses only the tangible form. Rather, it should incorporate a new way of update by which new dimensions, new functions, new beauty or appeal are added to synchronize the old witness architecture with the current context. Through the study of the potentials of KeyArena, this thesis proposes a forward-thinking strategy of preservation that strives to visualize the hidden layers of time that this building already persist, and to supplement it with newly intervened contemporary layer of utilities, that works in harmony with the existing, yet would not congeal into single image. In

the end, this adventurous preservation would update the old witness, enabling it to be a contributor to the nowness.

In January 2017, after one month of our thesis presentation, the City of Seattle issued a Request for Proposals for interested responders to develop a full scale renovation proposal of redeveloping and operating KeyArena. "We have a unique opportunity to reimagine KeyArena and continue the growth and redevelopment of Seattle Center. There is significant interest in working with the City of Seattle to create a civic arena that fulfills the current and future needs of our growing city that serves the greatest number of community members,"<sup>10</sup> said Mayor Ed Murray.

The timely KeyArena RFP demonstrates that the city and its people value the historic landmark as a regional asset and heritage in the development process of a city, and it is strategic to take advantage of the witness as a catalyst for new development. This echoes with the voice of this thesis that evokes the conversation to cherish the rich layers of the historic value of KeyArena, and use innovative preservation as an effective way to bring the historic witness to nowness.



# APPENDIX

## PHOTOS OF KEYARENA PRE-PROPOSAL MEETING AND BUILDING WALK THROUGH, JANUARY 25TH, 2017



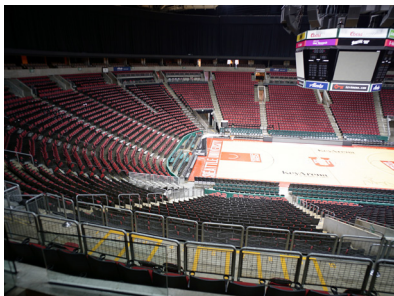
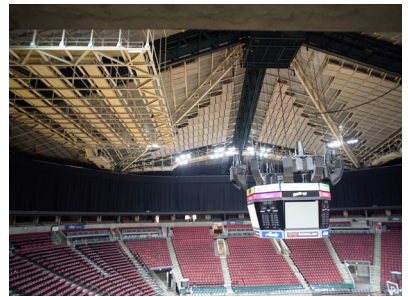
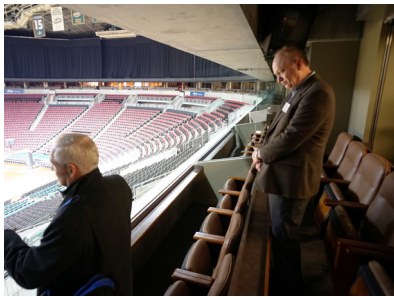
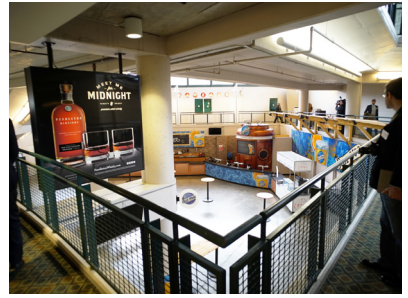

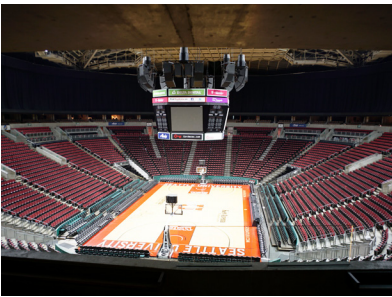

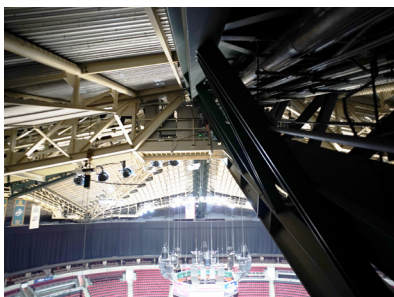
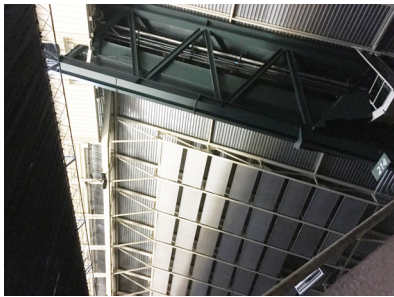

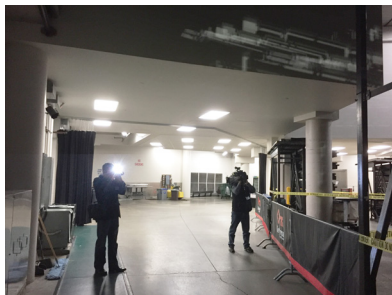
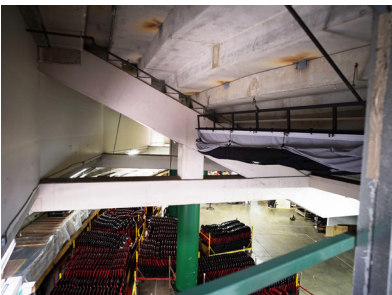
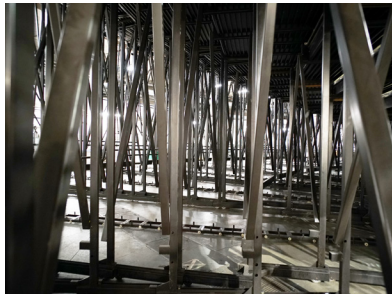

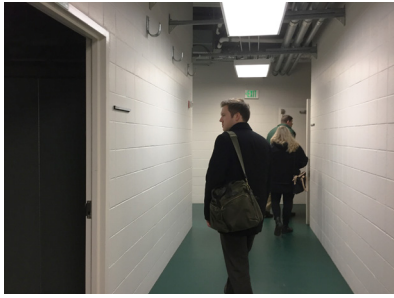

# REFERENCE

## WITNESS

1. Rem Koolhaas, in Conversation with Mohsen Mostafavithe on 2016 AIA Convention.
2. *Century 21 Exposition* (T890.2 1962 D5 C46 1959 Oversize, University Library, Special Collection, University of Washington).
3. T890.2 1962 L1 C464 1962, University Library, Special Collection, University of Washington.
4. Ibid.
5. *KeyArena Subcommittee Final Report and Recommendations*, February 15, 2006, Seattle City Hall Archive.
6. Ibid.
7. Russell Js, "Arena Trades In Cables For Trusses," *Architectural Record*, February 1996, Vol.184(2), pp.42-47.
8. *KeyArena Subcommittee Final Report and Recommendations*, February 15, 2006, Seattle City Hall Archive.
9. Ibid.

## NOWNESS

1. *The Merriam-Webster Dictionary*, Britannica Company.
2. "Seattle's Comprehensive Plan," Office of Planning & Community Development, <<http://www.seattle.gov/dpd/cityplanning/completeprojectslist/comprehensiveplan/documents/>>
3. "Seattle's Comprehensive Plan," November 2016, Office of Planning & Community Development, <<http://www.seattle.gov/dpd/cityplanning/completeprojectslist/comprehensiveplan/whatwhy/>>
4. "Voters approve historic Sound Transit 3 measure," November 10, 2016, Sound Transit, <<http://www.soundtransit.org/About-Sound-Transit/News-and-events/News-releases/voters-approve-historic-sound-transit->

3-measure>

5. *Part II: Regional Growth Strategy, Vision 2040*, Puget Sound Regional Council, p19.
6. *Uptown Urban Design Framework*, May 2016, Seattle Office of Planning and Community Development, p10.
7. Carolyn J. Marr, Nile Thompson, *Building for Learning: Seattle's Public School Histories, 1862-2000*, 2002, p.2.

#### PRE-PROPOSAL

1. "Holland Green," OMA, <<http://oma.eu/projects/holland-green>>
2. "London: The New Design Museum by John Pawson," November 23, 2016, *Inspirational Designers*, <<http://www.covethouse.eu/london-new-design-museum-john-pawson/>>
3. "Market Hall," MVRDV, <<https://www.mvrdv.nl/projects/markethall/#>>
4. Ibid.
5. "Souterrain Tram Tunnel," OMA, <<http://oma.eu/projects/souterrain-tram-tunnel>>
6. Ibid.
7. Jenna McKnight, "Santiago Calatrava's World Trade Center Transit Terminal to Quietly Open Next Week," *Dezeen*, February 25, 2016.
8. Blake Gopnik, "Golden Seams: The Japanese Art of Mending Ceramics," *Washington Post*, March 3, 2009.

#### CONCLUSION

1. *The City of Seattle Request for Proposals for Redevelopment of KeyArena at Seattle Center*, January 2017, Seattle Economic Development, The City of Seattle, p.1.

## IMAGE CREDITS

Andy Aupperlee, [www.explosion5000.com/images/Pan3\\_30x9b\\_72dpi\\_sharp.jpg](http://www.explosion5000.com/images/Pan3_30x9b_72dpi_sharp.jpg): 2-3

Google Map: 9 top, 39

<https://pauldorpat.com>: 9 bottom, 12, 13 top

[http://charles-mikkelshus.blogspot.com/2011\\_04\\_01\\_archive.html](http://charles-mikkelshus.blogspot.com/2011_04_01_archive.html): 11 top

University Library, Special Collection, University of Washington: 11 bottom

George Carkonen / The Seattle Times: 13 bottom

Victor Lygdman, <https://pauldorpat.com/2013/01/05/seattle-now-then-frank-shaws-big-neighbor/>: 14 top, 15 top

Paul V. Thomas / The Seattle Times: 14 bottom

<http://www.qahistory.org/key-arena/>: 15 bottom

Frank Shaw, <https://pauldorpat.com/2013/01/05/seattle-now-then-frank-shaws-big-neighbor/>: 16-17, 19 bottom

Vic Condiotty / The Seattle Times: 19 top

Scott Takushi / The Seattle Times: 21 top

Dan Crowell: 21 bottom

<https://www.flickr.com/photos/aepennypacker/3020399444>: 23 top

Lara Swimmer: 23 bottom

Seattle DCI Microfilm Library: 24-25

Seattle Municipal Archives: 27

Rod Mar / The Seattle Times: 29 top

The Seattle Times: 29 bottom

U.S.Census Bureau: 33 top

Office of Planning & Community Development: 33 bottom

Sound Transit: 35

Seattle Public School: 37

Gareth Gardner: 48 top, 51 bottom

OMA: 51 top, 55 top, 55 middle

Philip Sayer: 51 middle

MVRDV: 53 top, 53 middle

<http://www.bonsaitreegardener.net>: 59

<http://trendland.com/kintsugi-the-art-of-broken-pieces/>: 61

Texlon ETFE roof system, vector foiltec: 123 top

Europe Up Close, Copenhagen's Torvehallern: the World's Best Covered

Market: 123 middle

IESNA: 123 bottom

All other images are created by authors.

# ACKNOWLEDGMENTS

This thesis would not exist without support from:

The Department of Architecture at University of Washington, where our exploration in architecture was backed with dedicated faculties and comprehensive education. The rich offering of courses, including study abroad programs, gave us stages to learn from many brilliant minds about architecture and about the mentalities an architect should have.

Robert Hutchison, for constantly pushing us forward, raising the bar over and over again, and expanding our views from architecture to broader artistic creation, from day-1 in our 3-month trip to Mexico City, to the RHA MEM models, and to this thesis.

Dave Miller, for your insightful comments, innovative and decisive suggestions throughout the thesis process, and your constant pursuit in architecture, both in Seattle and Australia, that influenced us to keep running forward.

Cory Mattheis, for supporting us as a teacher, a neighbor, a colleague, and a friend. Your explorative attitude and endless energy always stimulate us from concept to presentation.

Ourselves, for supporting each other, polishing our thinking, and sharing countless moments in life with architecture and without.

Xiaoxi Jiao & Kejia Zhang, March 2017

