

Architecture for a Regional Food System :
A Food Hub for the Beacon Hill Neighborhood

Calaa O'Donnell

A thesis
submitted in partial fulfillment of the
requirements for the degree of

Master of Architecture

University of Washington
2016

Committee:
Brian McLaren
Gundala Proksch

Program Authorized to Offer Degree:
Architecture

©Copyright 2016
Calaa O'Donnell

University of Washington

Abstract

Architecture for a Regional Food System :
A Food Hub for the Beacon Hill Neighborhood

Calaa O'Donnell

Chair of the Supervisory Committee:
Associate Professor, Chair, Brian McLaren PH.D.
Associate Professor, Gundala Proksch

Throughout the history of civilization there has been a close and mutually beneficial relationship between food and cities. However due to industrialization of our contemporary food network the tangible connections to food that were once present in the urban landscape have been lost. Supermarkets have replaced the public market, the traditional site for local production and social engagement within the urban landscape. As the main point of connection with consumers of our current system, food retailers have contributed to the opaqueness of food networks and isolated city residents from the food that sustains them. Furthermore, these changes between the tangibility and transparency of food within the contemporary urban landscape have also deteriorated the public spaces

As a renewed desire for tangible connections with food continues to gain hold within urban communities, new approaches to the way in which the food engages with the city have emerged. One model that has recently gained attention is the food hub. Although these emerging models address rising desire by customers to engage in local food networks these facilities still reflect the typology of the modern supermarket. In order to appropriate the food hub for the urban scale and renew the market as a site for social engagement this thesis proposes a network of neighborhood based food hubs for Seattle, focusing on the design of a food hub for the Beacon Hill neighborhood. The goals for such a food hub will be to engage the community by deriving its program from the existing and desired elements within the community. This thesis will improve the quality of public space by providing opportunity for social engagement on multiple of scales, as well as unify food production with consumer through a multifaceted neighborhood facility. The thesis explores how food and architecture can be used to create a place specific design that supports a local food system and social engagement within an urban community.

Table of Contents

List of Figure	iv
1. Cultivating the City	1
2. From Market to Supermarket	4
3. A Food Hub for the City	16
4. Foulee Food Hub	30
5. Conclusion	51
Work Cited	53

List of Figures

- 1 *Foulee Food Hub During a Neighborhood Event* - Source : Author
- 2 *Lexington Market in Baltimore, MD.* - Source: <http://cdn.loc.gov/service/pnp/cph/3a10000/3a18000/3a18000/3a18095v.jpg>
- 3 *Thanksgiving Meal at Lexington Market , 1950's.* - Source: http://darkroom.baltimoresun.com/wp-content/uploads/2012/11/AEK-791-BS_F1.jpg
- 4 *Piggly Wiggly Supermarket , TN.* - Source: <http://beachpackagingdesign.com/wp-content/uploads/2012/09/PigglyWiggly-AL-1971.jpg>
- 5 *Early Interior of a Piggly Wiggly Grocery Store, 1918.* - Source: <http://iliketowastemytime.com/sites/default/files/historical-photos-pt8-piggly-wiggly-memphis-1918.jpg>
- 6 *Industrial Food System* - Source : Author
- 7 *Food Hub System* - Source : Author
- 8 *Typical Food Hub Model vs Expanded Model* - Source : Author
- 9 *Exterior View of The Wedge.* - Source: <http://vp.cdn.cityvoterinc.com/GetImage.ashx?mg=00/00/00/00/94/73/9473-37231.jpg>
- 10 *Interior view of The Wedge.* - Source: <http://www.maforever.com/Content/images/MaaPortfolio/20160411034812218994553325325.j>
- 11 *Ariel Rendering of Food Port.* - Source: <http://aasarchitecture.com/wp-content/uploads/Food-Hub-Master-Plan-by-OMA-00.jpg>
- 12 *Render within the Food Port Complex.* - Source: <http://cdn.archinect.net/images/650x/fa/fa4f4959b6eb0d5b78ecc55bfef2fbc1.jpg>
- 13 *Typical Centralized Typology of a Food Hub* - Source: Author
- 14 *Proposed Typology based on Seattle Neighborhoods* - Source: Author
- 15 *The Connection of King County Agricultural Lands with Seattle* - Source: Author
- 16 *Existing Production Facilities* - Source: Author
- 17 *Existing Cold + Dry Storage Warehouses* - Source: Author
- 18 *Existing Supermarket* - Source: Author
- 19 *Existing Food Deserts* - Source: Author
- 20 *Existing P-patches + Farmers Markets* - Source: Author
- 21 *All Existing Facilities + Beacon Hill Neighborhood* - Source: Author
- 22 *Beacon Hill Neighborhoods* - Source : Author
- 23 *Beacon Hill Light Rail Station* - Source : https://commons.wikimedia.org/wiki/File:Beacon_Hill_Light_Rail_Station_two.JPG
- 24 *Jefferson Park* -Source : <http://beaconhill.seattle.wa.us/tag/beacon-mountain/>
- 25 *VA Medical Center* - Source : http://www.vareview.net/wp-content/uploads/2016/07/300_o-1.jpg, <http://www.vareview.net/places/united-states/washington/seattle/hospital/va-puget-sound-health-care-system-seattle-division/>
- 26 *National vs Immigrant Residents* - Source : Author
- 27 *Neighborhood Cultural Communities* - Source : Author
- 28 *Existing Beacon Hill Food Facilities* - Source: Author
- 29 *Beacon Hill Food Forest.* - Source : Author
- 30 *Neighborhood Plant Stand* - Source : Author
- 31 *My Mother's Garden Community P-patch* - Source : Author
- 32 *Beacon Hill Café* - Source : https://s3-media3.fl.yelpcdn.com/bphoto/J_LkyE4LYMCRM3wtaHDJqw/o.jpg
- 33 *Dim Sum House, Phoenix Café + Montis Grill* - Source: Author
- 34 *VA Medical Center Pop-Up Market* - Source: <http://beaconhill.seattle.wa.us/tag/farmers-market/>
- 35 *Foulee Market* - Source : Author
- 36 *Seattle Super Market* - Source: Author
- 37 *Neighborhood Desires Documented by Seattle's Department of Neighborhoods* - Source : Author
- 38 *Proposed Decentralized Site Strategy* - Source : Author

39	<i>Four Corner Site of Foulee Food Hub</i> - Source : Author
40	<i>Proposed Infrastructure Improvements</i> - Source : Author
41	<i>Ground Floor Strategy</i> - Source : Author
42	<i>Community Connections</i> - Source : Author
43	<i>Housing Strategy</i> - Source : Author
44	<i>Food Hub Reinforced</i> - Source : Author
45	<i>Strategy for Social Engagement</i> - Source : Author
46	<i>Foulee Food Hub During Neighborhood Event</i> - Source : Author
47	<i>Design and Program for Northwest Corner Site</i> - Source : Author
48	<i>Northwest Corner Site During the Day</i> - Source : Author
49	<i>Design and Program for Northeast Corner Site</i> - Source : Author
50	<i>Morning at Northeast Corner Site</i> - Source : Author
51	<i>Design and Program for Southeast Corner Site</i> - Source : Author
52	<i>Evening in the Biergarten</i> - Source : Author
53	<i>Bent Form</i> - Source : Author
54	<i>Public Growing</i> - Source : Author
55	<i>Social Engagement</i> - Source : Author
56	<i>Community Connections</i> - Source : Author
57	<i>Connection of Production</i> - Source : Author
58	<i>Interconnection of Program</i> - Source : Author
59	<i>Design of Market and Food incubator Corner</i> - Source : Author
60	<i>The Plaza at eh Market and Food Incubator Corner</i> - Source : Author
61	<i>Floor Plan of Market and Food Incubator Corner</i> - Source : Author
62	<i>Program Layout of Market and Food Incubator Corner Use</i> - Source : Author
63	<i>Timeline of Market and Food Incubator Corner Use</i> - Source : Author
64	<i>Exterior View of Market</i> - Source : Author
65	<i>Section of Market</i> - Source : Author
66	<i>Interior View of Market</i> - Source : Author



Image 1 : Foullee Food Hub During a Neighborhood Event

Chapter 1 : Cultivating the City

“The public culture of food brings vitality and conviviality to urban life. People come together in public spaces to buy and to eat, and even to grow food, and in these ways, also, to be with others.”

– Karen A Franck , *The City as Dining Room, Market and Farm* ¹

Throughout the history of civilization there has been a close and mutually beneficial relationship between food and cities.² However due to industrialization of our contemporary food network the tangible connections to food that were once present in the urban landscape have been lost. Supermarkets have replaced the public market, the traditional site for local production and social engagement within the urban landscape. As supermarkets have become the main point of contact between food and urban residents, the consumers relationship with food has been altered. These changes between the tangibility and transparency of food within the contemporary urban landscape have also deteriorated the public spaces, characterized above by Karen Franck, which unified urban residents through food.

In the past markets have typically been located in the heart of cities, sustaining the life of local residents and creating a stage for the civic engagement. The public marketplace not only provided a hub for the daily distribution, production, and consumption of food within cities but they also fostered a place for community interaction.³ But as Carolyn Steel argues, the process of modernizing the system for the convenience of the food industry has negatively impacted public interaction with food. The production of food, which was often located in the city, has almost been entirely removed to the periphery, relegated to manufacturing facilities in the rural landscape. The model of the suburban supermarket has almost completely replaced public markets, substituting streamlined service and mass-produced products for the civic engagement that came with the daily interaction of food exchange. While public markets have had resurgence in many major cities, they are often tourist destinations, with restricted hours throughout the week, leaving the majority of urban residents still relying on supermarkets for food.

As a renewed desire for tangible connections with food continues to gain hold within urban communities, new approaches to the way in which the food engages with the city have emerged. One model that has recently gained attention is the food hub. Although

these models address rising desire by customers to engage in regional food networks these facilities still reflect the typology of the modern supermarket. In order to appropriate the food hub for the urban scale and renew the market as a site for social engagement this thesis proposes a network of neighborhood based food hubs for Seattle, focusing on the design of a food hub for the Beacon Hill neighborhood. (Image 1) The goals for such a food hub will be to engage the community by deriving its program from the existing and desired elements within the community, it will improve the quality of public space by providing opportunity for social engagement on multiple of scales, as well as unify food production with consumer through a multifaceted neighborhood facility. The thesis explores how food and architecture can be used to create a place specific design that supports a regional food system and social engagement within an urban community.

End Notes

- 1 Franck, Karen A. "The City as Dining Room, Market and Farm." *Architectural Design* 75.3 (2005): 5-10. Web.
- 2 Steel, Carolyn. *Hungry City: How Food Shapes Our Lives*. London: Chatto & Windus, 2008. Print.
- 3 *Ibid.* 118

Chapter 2 : From Market to Supermarket

In her book *Hungry City: How Food Shapes Our Lives*, author Carolyn Steel traces the way in which the supply and consumption of food has effected the way in which one inhabits the city, ultimately molding the way the built environment. Urban spaces like the public markets and restaurants have provided a backdrop for urban life that served people's basic needs but also encouraged social exchange and interaction. ⁴ These traditional ways in which cities were fed depended on a multitude of facilities that supplied and sustained regional urban food systems. ⁵ This model is drastically different than the contemporary food industry found within cities, which is controlled by international corporations. Feeding growing cities today requires a massive effort; continued expenditure of resources has major social and environmental impacts on the planet. The degradation of the environment and the threat to human health created by the modern food industry are often overlooked, but by examining the shift from the market to the supermarket the impact is evident.

The Market

The influence of food on how the form and function of cities is evident in pre-industrial urban design. The market, the heart of local exchange, was often located at the center of the city with arterial streets leading to it. ⁶ As cities grew larger these streets typically became part of the market itself. While this could cause chaos within the urban fabric it was necessary for life. Within the expanded space of the public markets food was transported, produce and, consumed. But these spaces were often also used for public events such as holiday celebrations and public feasts. ⁷ The call to clean up cities during the Victorian era meant the end to the vast majority of open trade within city streets but the social engagement between food and cities continued with grocers and small market shops. ⁸ This new typology for the way in which food was sold in the city brought rise to urban hubs made possible by a congregation of multiple market shops that supported the life of the local residents. These congregations of shops continued to support the majority of urban life until WWII when mass production in manufacturing was translated into mass production on the food industry.

In her book Carolyn Steel suggests that, "where food markets survive they bring a quality of life that is all to rare; a sense of belonging,



Image 2 : Lexington Market in Baltimore, MD

engagement, character.” Though Steel focuses her study on European market models her ideas can also be applied to markets within the American city. For example, the Lexington Market in Baltimore is one such establishment that has been supporting local communities since the late 18th century.⁹ The market’s current downtown location was once an open field where farmers congregated to sell their goods. The many trips taken by farmers to this site established a series of roads that were eventually enclosed by a permanent structure. As the city population swelled in the early 20th century Lexington Market grew to contain 1,000



Figure 3 : Thanksgiving Meal at Lexington Market , 1950's

vendors who occupied the market structure and the streets around, creating a social hub within the city. (Figure 2) Though the market does not house as many vendors as it once did, due to competition from industrial production, it continues to serve as a community institution that provide local Baltimore residents with a connection to regional food produce. (Figure 3) supermarkets enjoyed the economic gain that public markets once did but no longer played a role in urban civic life. Where as markets were the hub of food and social engagement supermarkets consciously removed social aspects in order to focus on what they were good at



Image 4 : Piggly Wiggly Supermarket, TN, 1950's

The Supermarket

In the early 20th century in order for food processing companies to sell their products in high-volumes, as cost-effectively as possible, supermarkets were created.¹⁰ As food production facilities became larger and were removed from cities, supermarkets became the main point of connection with consumers. Supermarkets also became the most complex stage within the system due its relation with the human scale.¹¹ Since the modern food industry was most effective at the macro scale it's connection to the micro scale of the individual was more



Image 5 : Early Interior of a Piggly Wiggly Grocery Store, 1918

problematic. As a result the larger scale of the supermarket was less compatible with central urban locations, leaving them to operate on its outskirts, making customers come to them.¹² (Image 4) In the interest of further cutting costs and providing customers with the cheapest products they could find, supermarkets streamlined customer service. The Piggly Wiggly supermarket chain, which was established in 1916, is noted for introducing self-service into grocery stores.¹³ (Image 5) Although the use of turnstiles, grocery baskets, and checkout queues were radical features at the time, they are common elements in supermarkets today.

The decision to streamline customer service meant that supermarkets enjoyed the economic gain that public markets once did. But due to their suburban location and selling strategies, this new food center no longer played a role in urban civic life. Whereas markets were the hub of food and social engagement, supermarkets consciously removed social aspects in order to focus on what they were good at providing cheap food in bulk.¹⁴ While shifting trends in American culture mean more people are moving back to cities from the suburbs there are also shifting trends within food culture. With these shifting trends and a growing knowledge of contemporary practices in the food industry customers are demanding quality food products over quantity. Even though there have been changes in cultural trends there has not been any changes to the way in which food engages with the built environment. The supermarket is still the dominant architectural type of food retail in the city. Though the industrial food system promised to make feeding cities easier it is more difficult to orchestrate its vast systems. The complexity of these systems and its effect on the city can be seen in the evidence of “food deserts”. As Carolyn Steel argues the urban food system changed for the convenience of the industry’s corporations swaths of urban neighborhoods are left without access to fresh food.¹⁵ While supermarkets have filled our contemporary need for

convenience they have contributed to the loss of public life within cities, and to the loss of the physical expression of urban vitality.

The Food Hub

As the detrimental effects of the industrial food system have become more apparent there has been an increasing demand by customers for locally produced food. Food hubs have emerged as a mechanism to connect small and mid-scale food producers with the public by providing a physical and social infrastructure for the distribution of regional food. These institutions have gained the recognition of the United States Department of Agriculture, who defines them as a, “centrally located facilities with a management structure facilitating the aggregation, storage, processing, distribution and/or marketing of locally/regionally produced food products.”¹⁶ Though the USDA has provided this definition of a food hub they also acknowledge that they can take on various forms that respond to the community they serve.

Key Components

While the term “food hub” varies the USDA has provided a basic definition to illustrate its use for regional food systems. In attempts to distinguish food hubs system from those of the industrial system (Image 6) three key components of operation have been defined as;

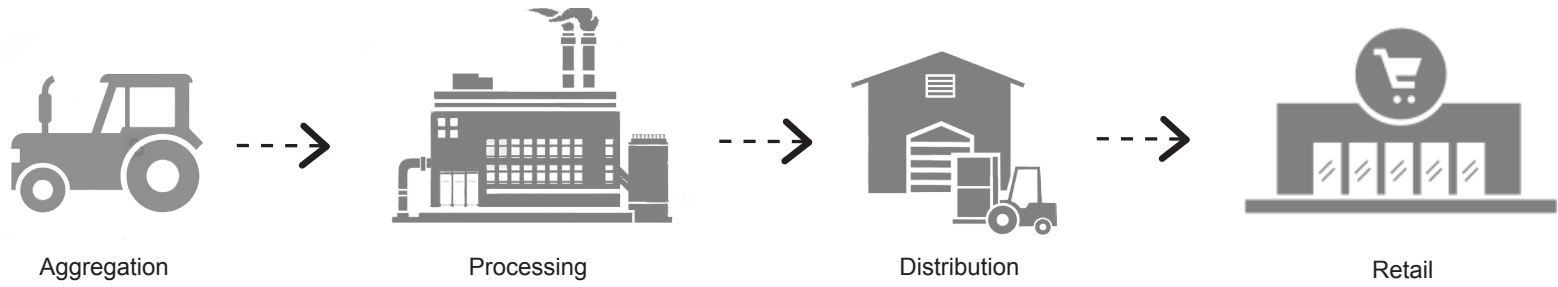

Image 6 : Industrial Food System

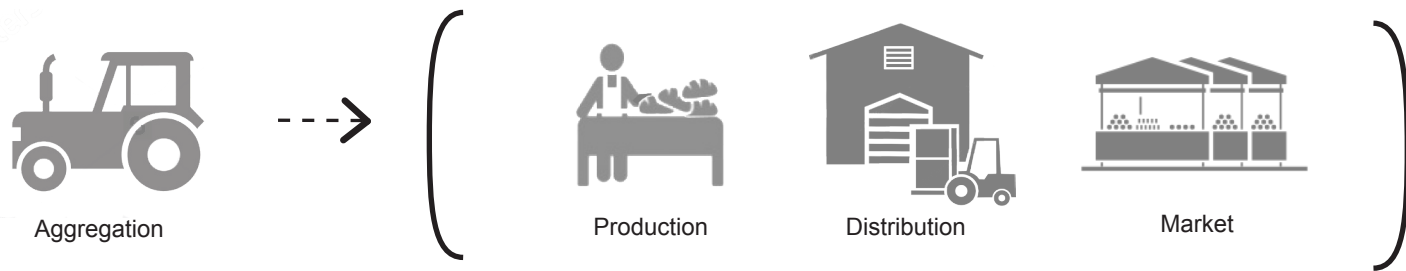

Image 7 : Food Hub System

Aggregation/distribution: Drop-off location for multiple farmer and pick-up points for community distributors (restaurants, schools, hospitals)

Active coordination with food producers: On-site management that coordinates supply chain logistics including marketing

Permanent facilities: Space and equipment for food to be stored, lightly processed, packed, and sold under an individual vendor or collective hub label

While these three components are part of the core elements that make up a food hub (Image 7), the USDA also recognized that a majority of food hubs provide space for additional social services like health education programs, community kitchens and community gathering space.¹⁷

Common Goals

In general basic goal of the food hub is to provide a means to fulfill customer demand for regional food products. But the USDA has also identified other benefits that result from the establishment of these food centers;¹⁸

Communication and industry access: Increased collaborations between regional food producers for efficient movement of food^x

A reduction in barriers to market: Providing previously limited local producers the ability to start their own business through better

Economic development: Promote the viability of local farmers and produce while increase employment opportunities within the neighborhoods they serve

Public health: Increasing public access to and understanding of fresh food

Education opportunities: Support interest in agriculture through educational culinary and farming programs

By providing these additional programs to the core elements of the food hub, these facilities not only become a place for local residents to access regional produce they become a center of social engagement within the community. For this reason I propose an expanded food hub model (Image 8), which uses the core elements proposed by the USDA, as well as additional services like dining and community services in order to promote social engagement within these new facilities. While these guidelines provide a basic description of the function of a food hub, how these translate to the scale of a neighborhood community and to an architectural language are not demonstrated. Therefore an examination of food hub projects is necessary in order to explore the role architecture can play in reconnecting food and the city.

Typical Food Hub Model



Proposed Expanded Food Hub Model

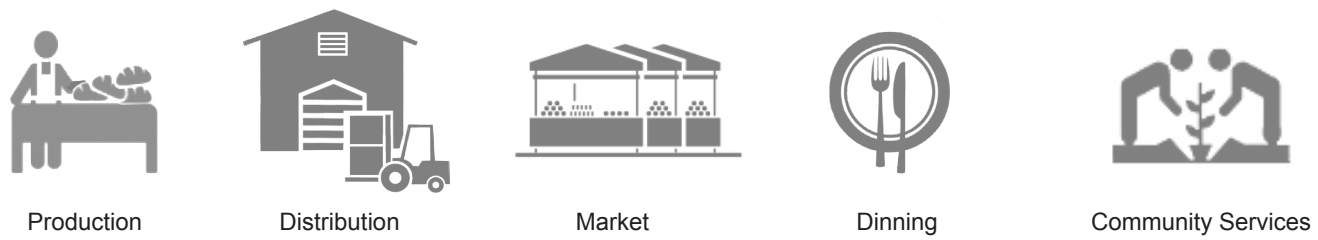

Image 8: Typical Food Hub Model vs Expanded Model

Existing Food Hubs

The following case studies of food hubs within the United States, one proposed and one realized, will be examined in order to understand how these food centers are integrated into their communities.

The Wedge | Minneapolis, MN

Since its founding in 1974, The Wedge has served as a community institution for a South Minneapolis neighborhood. The name refers to the original wedge-shaped building where a small number of community members came together to rent out the basement to provide a neighborhood food store.¹⁹ Due to the success of the market it quickly outgrew its original space moving to the site of a former convenience store. (Image 9) The Wedge now consists of 56,000 square feet of operational space, consisting of community gathering space, a catering kitchen, a warehouse, and a grocery store.²⁰ Not only does The Wedge provide locals residents with access to over 5,000 regional food products (Image 10) but it also provides social services, such as agricultural education for students and training new farmers. While The Wedge provides local urban residents with access to regional products the facilities still take on the typology of the supermarket and big-box warehouse. Though this project provides precedent for how food hubs can provide community services



Image 9 : Exterior View of The Wedge



Image 10 : Interior view of The Wedge

that better engage local neighborhoods, further discovery is needed to understand how architecture can elevate the function of a food hub.

Food Port | OMA | Louisville, KY

In 2015 OMA unveiled their plans for a mixed-use project that seeks to consolidate facilities for the growing, selling, and distribution of food for local farmers in Louisville, Kentucky. (Image 11) The proposed plans call for a 24-acre food hub on the site of a former tobacco plant, that will include an urban farm, edible garden, market and food truck plaza, retail space, classroom, and a recycling facility.²¹ The city's motivation for this project was to create an "active economic and community hub", that will serve as a connection between local resident and regional producer. The design take advantage of the unique mix of tenants by introducing shared facilities where private producers and public consumers meet. (Image 12) OMA strengthens the idea of the food hub as a community center by deriving its form from pedestrian flows within its context, and ensure that public activities and exterior plazas are featured along these routes. This design proposed by OMA begins to explore how architecture can elevate the idea of the food hub as the center not only of regional food production but also of regional social engagement.



Image 11 : Ariel Rendering of Food Port



Image 12 : Render within the Food Port Complex

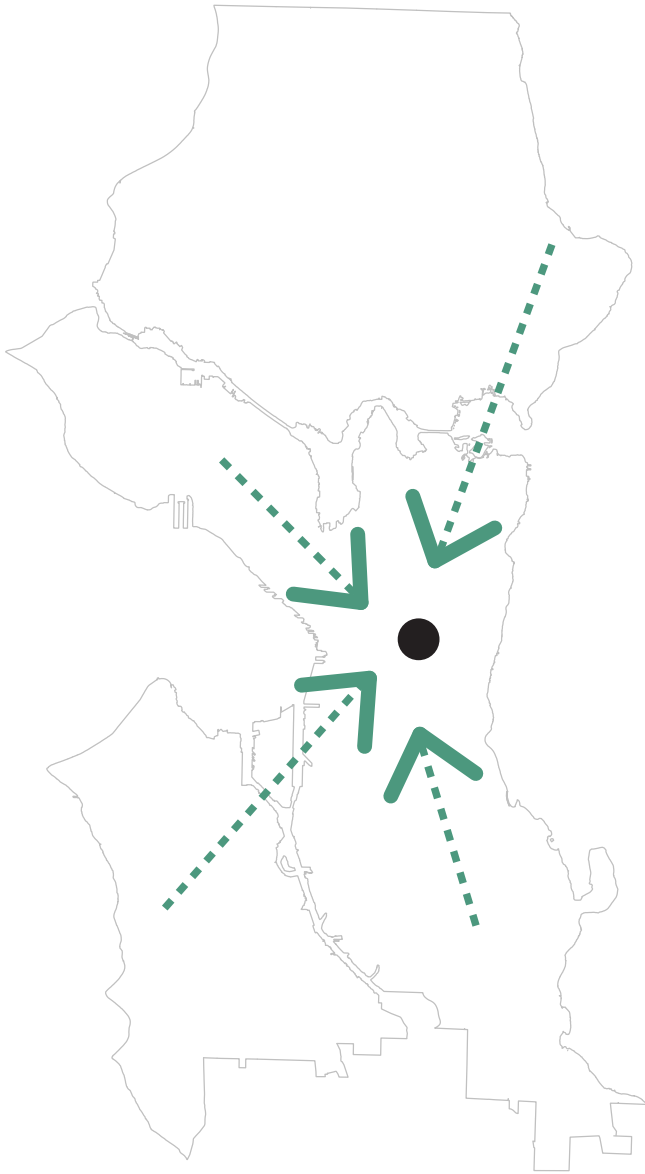

Image 13 : Typical Centralized Typology of a Food Hub

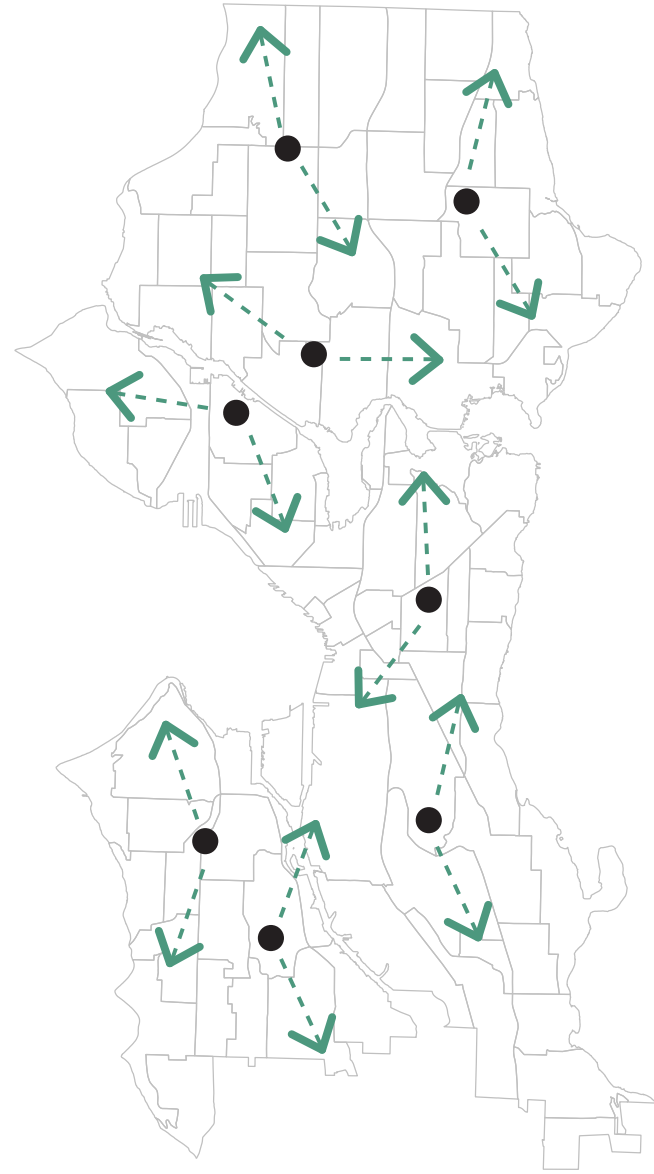

Image 14 : Proposed Typology based on Seattle Neighborhoods

Decentralizing the System

The Wedge and the Food Port share the common goals of food hubs set forth by the USDA, by providing permanent structures for the aggregation of regional products. Both projects also attempt to encourage the social engagement of local residents. Although both of these projects seek to address customer need for access to regional food and social engagement, they do so at the scale of the industrial food system, similar to the typology of the supermarket. This connection to the supermarket typology is further evident in the location of both projects on the outskirts of their respective cities. Architecturally, the two projects adopt the identity of the factory and the big-box store to identify themselves to the public. In order to establish an appropriate archetype for an urban food hub the scale of the facilities must integrate with its context. By using the city of Seattle as a testing ground, I propose a shift away from the typology of the food hub as a single centralized facility that serves an entire city (Image 13), and to a decentralized typology that allows neighborhood food hubs that address the needs of individual communities. (Image 14) Decentralizing the typical model for these community institutions will not only enable them to be community centers that can better serve the individual needs of a neighborhood,

but also allow these facilities to be integrate into the existing urban fabric. A more distinctive architectural language is also necessary for these community institutions, in order to identify them as the hub of food and social activity within a neighborhood.

End Notes

- 4 Franck, Karen A. "The City as Dining Room, Market and Farm." *Architectural Design* 75.3 (2005): 5-10. Web.
- 5 Steel, Carolyn. *Hungry City: How Food Shapes Our Lives*. London: Chatto & Windus, 2008. Print.
- 6 *Ibid.*, 118
- 7 *Ibid.*, 121
- 8 *Ibid.*, 132
- 9 "History." *Lexington Market*. *Hardly Square*, n.d. Web. <http://lexingtonmarket.com/history/>
- 10 Steel, Carolyn. *Hungry City: How Food Shapes Our Lives*. London: Chatto & Windus, 2008. Print.
- 11 *Ibid.*, 136
- 12 *Ibid.*, 136
- 13 *Ibid.*, 136
- 14 *Ibid.*, 136
- 15 *Ibid.*, 147
- 16 United States Department of Agriculture "Regional Food Hub Resource Guide" Web. <https://www.ams.usda.gov/sites/default/files/media/Regional%20Food%20Hub%20Resource%20Guide.pdf>
- 17 Jim Barham, "Regional Food Hubs: Understanding the scope and scale of food hub operations" (2011).
- 18 Know Your Farmer, Know Your Food Regional Food Hub Subcommittee, (Presentation). <http://www.ams.usda.gov/AMSV1.0/getfile?dDocName=STELPRDC5088011&acct=wdmgeninfo>
- 19 "About the Wedge." *Wedge Community Co-op*. Web. <http://www.wedge.coop/about-the-wedge/>.
- 20 *Ibid.*
- 21 Rosenfield, Karissa. "OMA Designs Food Port for West Louisville." *ArchDaily*. *Plataforma Networks*Plataforma Networks, 22 Feb. 2015. Web.<http://www.archdaily.com/601730/oma-designs-food-port-for-west-louisville>

Chapter 3 : A Food Hub for the City

The importance of the consumption of local food has become increasingly evident as customers become more educated about the source of their food for physiological, environmental, social and economic reasons.²² A recent survey by King County Agriculture Program found that 62 percent of respondents bought local food, either monthly or weekly.²³ The majority of the local produce is currently bought through direct-to-consumer sales, using venues such as farmers markets. A 2004 report from the American Farmland Trusts, describing the benefits as; “an increase in marketing and business development support for farmers, in retail and institutional food buying from local farmers, and in improving regulatory and other coordination among farmers.”²⁴ Establishing food hubs within the neighborhoods of Seattle would provide permanent facilities for local vendors to provide direct-to-consumer food system for urban residents. In order to determine appropriate locations for a food hub within Seattle it is necessary to understand the current conditions of the food network within the region. region.

Connecting the Regional Scale

Recent reports from the USDA indicate that each of the four counties within the Puget Sound Region desires to encourage and

sustain the viability of local farmers.²⁵ Though there is a desire by regional producers and consumers for a more robust regional food system, there are still factors that limit access to regional markets. King County has identified some of the barriers restricting regional farmers including access to commercial kitchens and market space.²⁶ In order to address

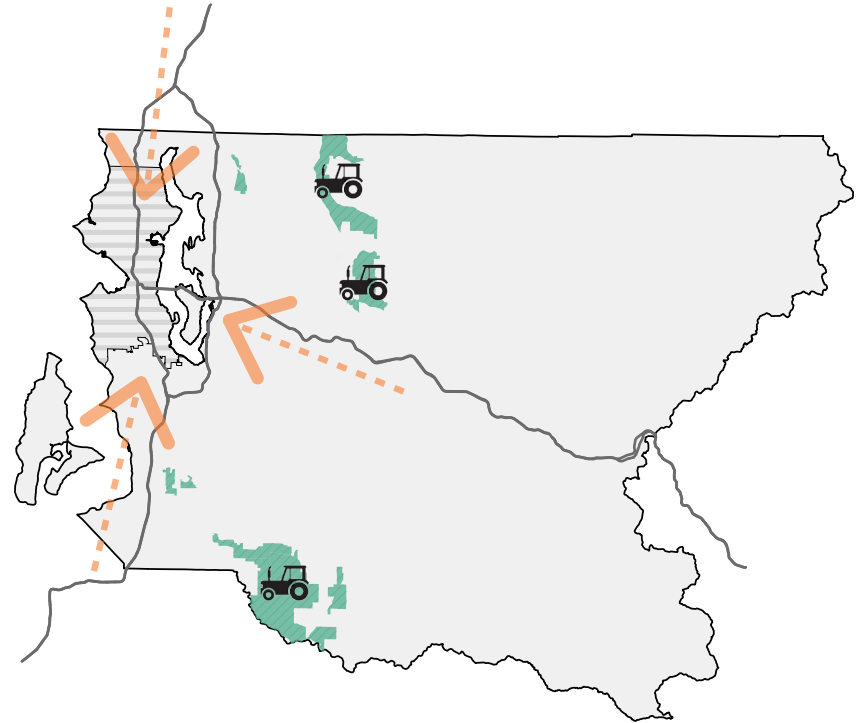

Image 15 : The Connection of King County Agricultural Lands with Seattle

the need for permanent space for local producers to connect with urban consumers it is necessary to understand how produce is transported from local farms within the region to the city of Seattle. An appropriate location for a food hub would take into consideration the ease of access for vendors to transport their produce as well as the convenience of the consumer. For this reason a site should be located close to main circulation routes through the city, including I-5 and I-90, but at the same time connected to the neighborhoods of the city. (Image 15)

Connecting the Urban Scale

Although an increasing number of Seattle residents use regional vendors for their food needs, the majority of residents within the city still rely on the industrial food system to meet their daily needs. The traditional processing and distribution facilities, associated with the industrial food system, are located in the industrial district, away from the supermarkets that are typical found in middle to upper class neighborhoods of Seattle. (Image 16,17,18) Analyzing the location of existing facilities not only gives insight into how food has shaped the growth of Seattle. But it also makes gaps in the current food system. These gaps occur where vulnerable populations do not receive the same access as other Seattle neighborhoods, these areas are referred to as food

deserts. (Image 19) The USDA defines food deserts as areas that lack access to fresh produce and other healthy foods, due to a lack of grocery stores and farmers' markets.²⁷ As populations continue to swell within the region it is important to address food deserts in order improve the quality of life of current and future residents. The proposed food hub will be located in a currently under served area where it can have the greatest impact. Not only should the food hub bring food to a currently under served community in Seattle, but it should also collaborate with existing regional food systems like farmers markets and p-patches. (Image 20) Due to its geographical connection to current food production in the ID district, the presences of food deserts within the neighborhood, and its residents enthusiasm for programs like p-patches and farmers market, this thesis will focus on a design of a food hub for the Beacon Hill Neighborhood. (Image 21)

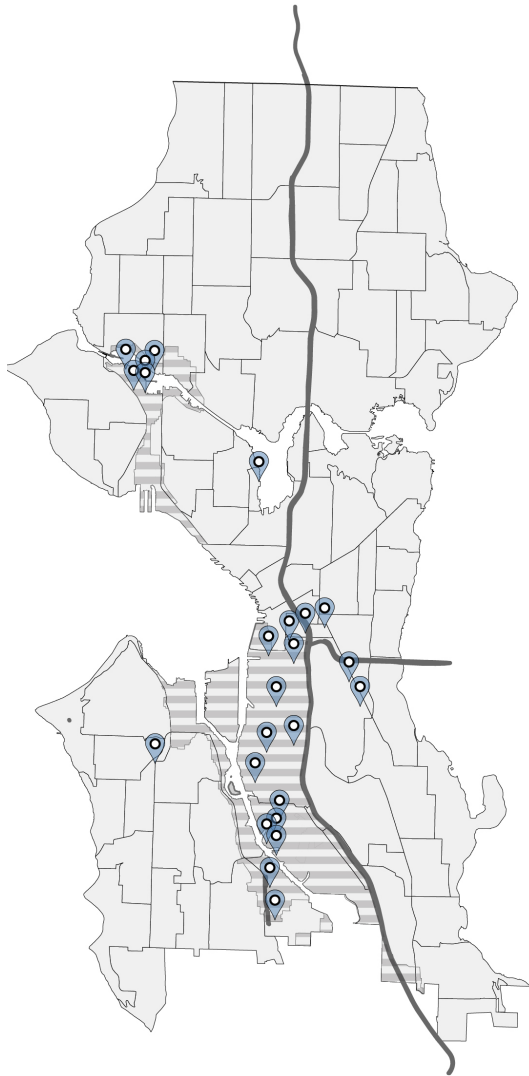

Image 16 : Existing Production Facilities

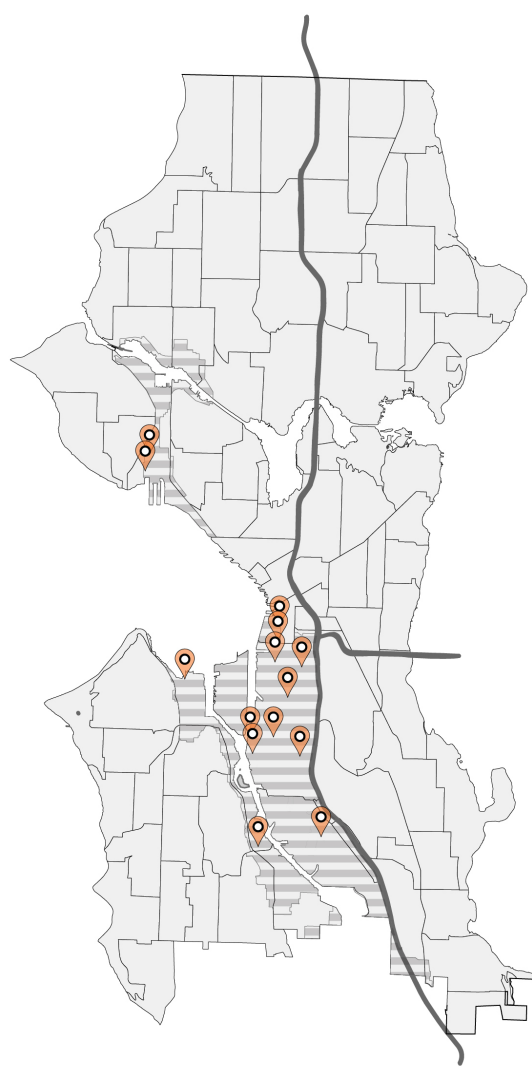

Image 17 : Existing Cold + Dry Storage Warehouses

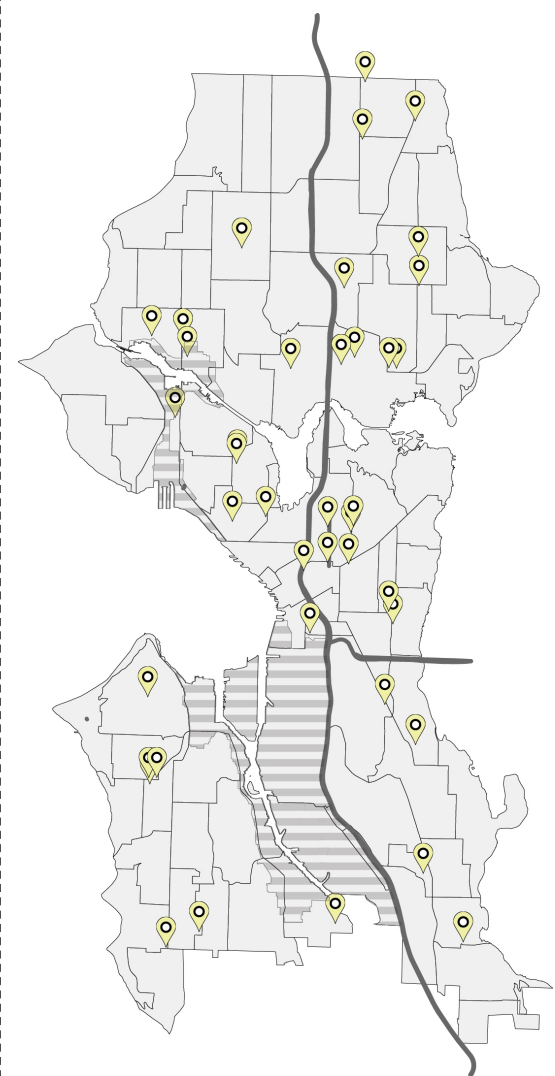

image 18 : Existing Supermarket

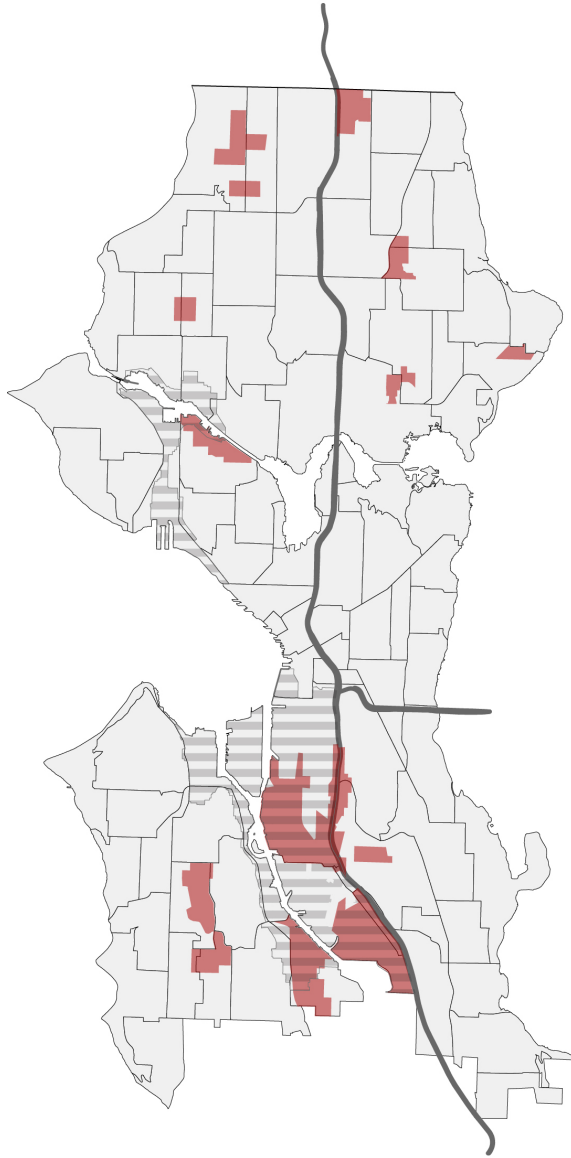

Image 19 : Existing Food Deserts

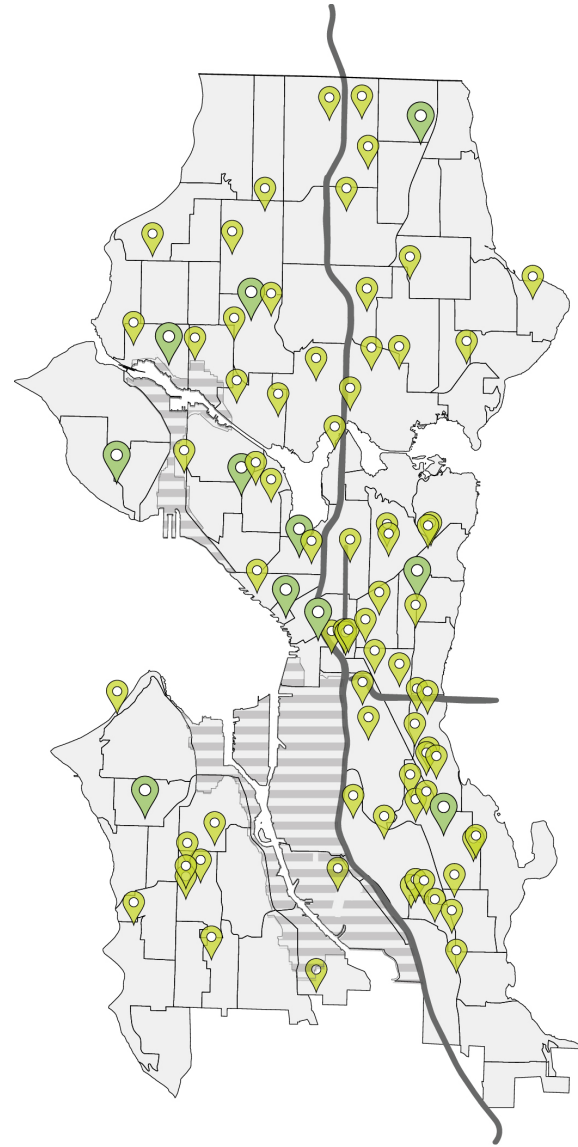

Image 20 : Existing P-patches + Farmers Markets

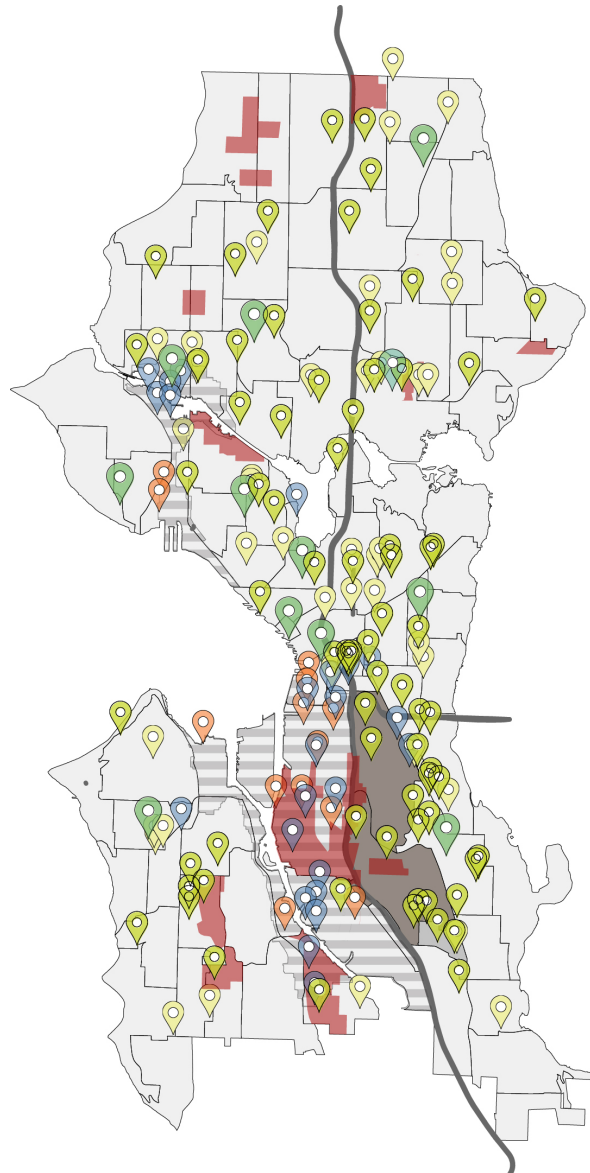

Image 21 : All Existing Facilities + Beacon Hill Neighborhood

Connecting the Neighborhood Scale

The land that is now Beacon Hill was originally considered undesirable when Seattle was first being settled because of its topography and seclusion from its surroundings. Once the hill was re-graded and trolley lines established many families moved to the neighborhood, a majority of whom were of Italian or Japanese descent.²⁸ These new communities took advantage of the land within the neighborhood and established gardens, selling the produce in the city. Not only did these immigrants farm the land within the neighborhood, but they also operated markets within the developing commercial districts.

The Beacon Hill neighborhood has continued to diversify throughout the years and currently is home to many communities of different backgrounds.²⁹ These diverse communities are spread throughout the three neighborhoods that make up Beacon Hill, North Beacon Hill, Mid Beacon Hill, and New Holly. (Image 22) While residents live among the three neighborhoods the majority of the community amenities are located in North Beacon Hill. These amenities include the Light Rail Station (Image 23), Jefferson Park (Image 24), and the VA Medical Center (Image 25). Though these



Image 22 : Beacon Hill Neighborhoods

Image 25 : VA Medical Center

existing amenities improve the quality of life for the residents of Beacon Hill and of the greater region, this thesis will explore how a neighborhood food hub could serve as a connector between these existing amenities in North Beacon Hill and the underserved communities to the South.

Connecting Diversity

Beacon Hill has historically been, and remains to this day, a diverse neighborhood of Seattle. Based on data from the US Census Bureau one can see that even as of 2014 the residents of the neighborhood came from a diverse background, with 54% of the population being of national origin and 46% being immigrant.²⁹ With the majority of nationally born residents living in the North Beacon Hill the majority of immigrants reside within the Mid Beacon Hill and New Holly neighborhoods. (Image 26) While the boundaries can be more easily defined between national and foreign born residents the boundaries of cultural backgrounds are more mixed within the community. (Image 27) The proposed site for this food hub

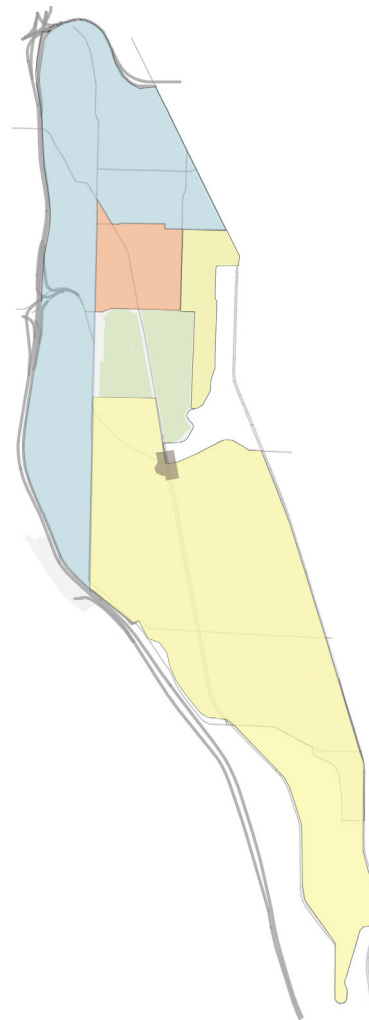

Image 26 : National vs Immigrant Resident

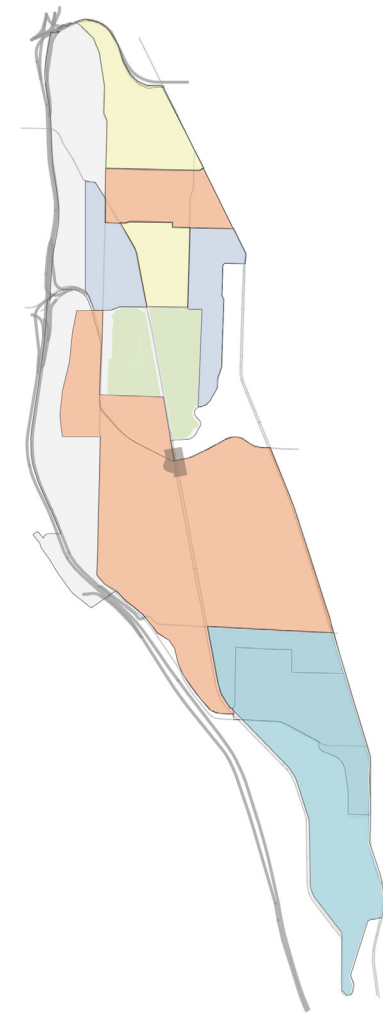

Image 27 : Neighborhood Cultural Communities

resides between national and immigrant communities, and strives to serve the many different cultural groups within the neighborhood. This approach to site selection strengthens the role of the food hub as a connector for social engagement.

Connecting to the Existing neighborhood Food System

Being a diverse neighborhood means that the Beacon Hill neighborhood has a diverse food culture to match. As stated in the analysis of existing food facilities in Seattle, Beacon Hill has a physical connection to both the traditional food system and the rebuilding of the regional food system. Many of the traditional food facilities, such as restaurants and supermarkets within the neighborhoods are congregated in North Beacon Hill. (Image 28) While this is convenient for those residents who live within that portion of the Neighborhood, those who live in the southern portion of the neighborhood are under served. What is available throughout the neighborhood is the access to growing spaces. These growing spaces can be found on private lawns or within community garden. The site selected for the seeks to increase food access to all members of the community, while leveraging the existing growing spaces within the Beacon Hill community.



Image 28 : Existing Beacon Hill Food Facilities

Connection to Growing

Growing has been a part of the Beacon Hill residents' identity since immigrant first arrived in the area.³⁰ What started as single family plots on individual property has flourished into community gardens that reclaim public land. The Beacon Hill Food Forest is one such project that has reclaimed public land, from Jefferson Park, in order to provide space for both private growing plots and a community garden that provides free food for the greater community. (Image 29) Growing had become such an integral part to the neighborhood that one resident has even taken it upon themselves to provide a plant stand in their front yard. (Image 30) This gesture not only supports the identity of the community as growers, but also shows that there is a desire for that identity to grow and occupy more of the neighborhood. While these new spaces dedicated to growing have emerged within the community, it is the immigrant gardens that still serve as the backbone of the neighborhood. Such as My Mothers Garden, a community garden located just south of the proposed food hub site, and devoted to immigrants from Laos and Thailand. (Image 31)



Map of Neighborhood Context - Source : Author

Connection to Dining

Though the majority of dining experiences in the neighborhood are located in North Beacon Hill, there are a few options for cultural dining elsewhere in the community. Those dining facilities found outside North Beacon Hill share a typology of a single-storey retail strip. These strips of retail are typically found at the corner of a busier neighborhood intersection and house a mix of commercial properties. While dining spaces are not diverse in type, they do provide a snapshot of the diverse cultures of the neighborhood. At one corner of the neighborhood you will find restaurants influenced by the Hispanic community (Image 32), while another other corner identifies Asian influence. (Image 33)

Connection to the Market

Like the opportunity to dine, the opportunity for food markets outside of North Beacon Hill are limited but non-the less present. An informal market occupies the southern edge of the VA medical Center during the

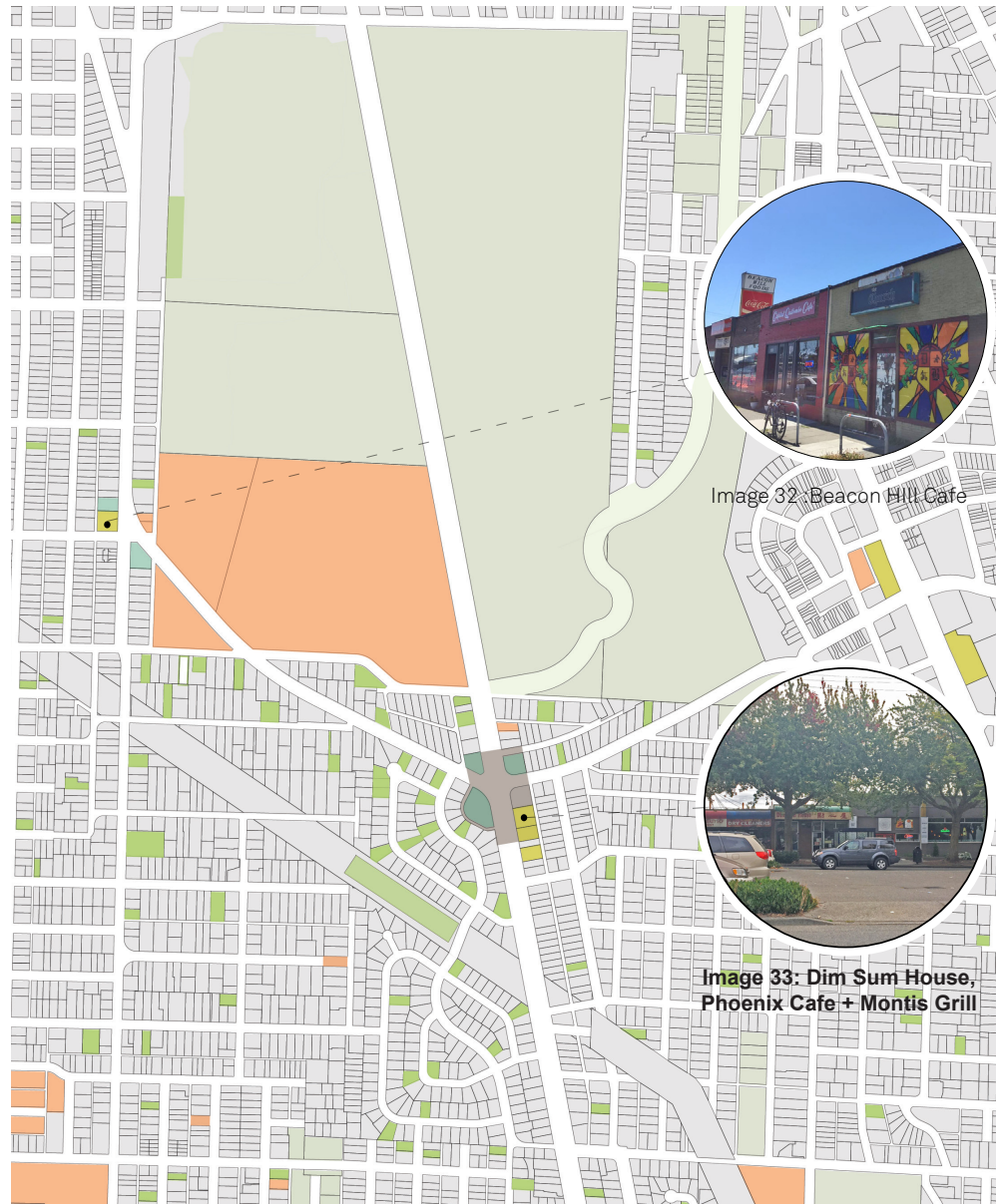

Map of Neighborhood Context - Source : Author

summer months. (Image 34) Though the market started out of the back of a single truck, it continues to grow each year, and has become a much-anticipated event within the community. There are also two existing supermarkets located within the proposed site of the food hub, the Foulee Market (Image 35) and Seattle Super Market (Image 36). While both of these stores cater to the diverse cultures in the neighborhood, particularly to the Chinese and Filipino populations, they still depend on the industrial food system and restrict social engagement.

Connecting the Program

Though existing food facilities within the Beacon Hill neighborhood reflect the culture of the local community, these spaces are disconnected much like many of the facilities that make up the industrial food system. With the intent of the neighborhood food hub to connection local resident with social and regional food system, the program for the food hub seeks to meet the individual needs of the community it serves. To achieve

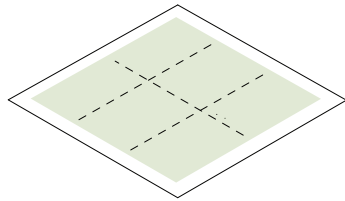

Image 34: VA Medical Center Pop-Up Market

Image 35: Foulee Market

Image 36: Seattle Super Market

Map of Neighborhood Context - Source : Author



P - Patches

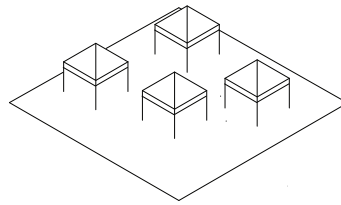

Informal Market

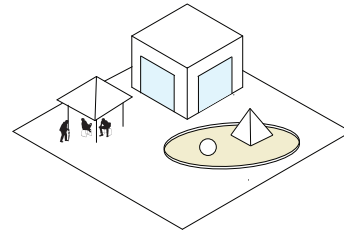

Child + Elder Activities

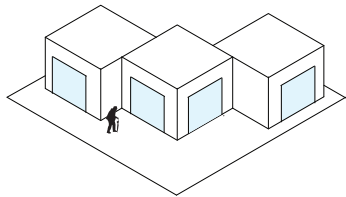

Small Buisnesses

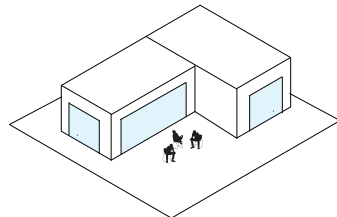

Cafes + Restaurants

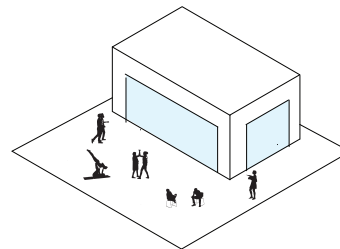

Community Center

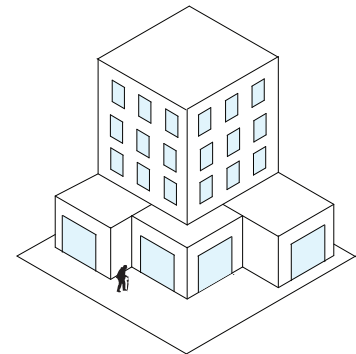

Housing over Buisnesses

Image 37: Neighborhood Desires Documented by Seattle's Department of Neighborhoods

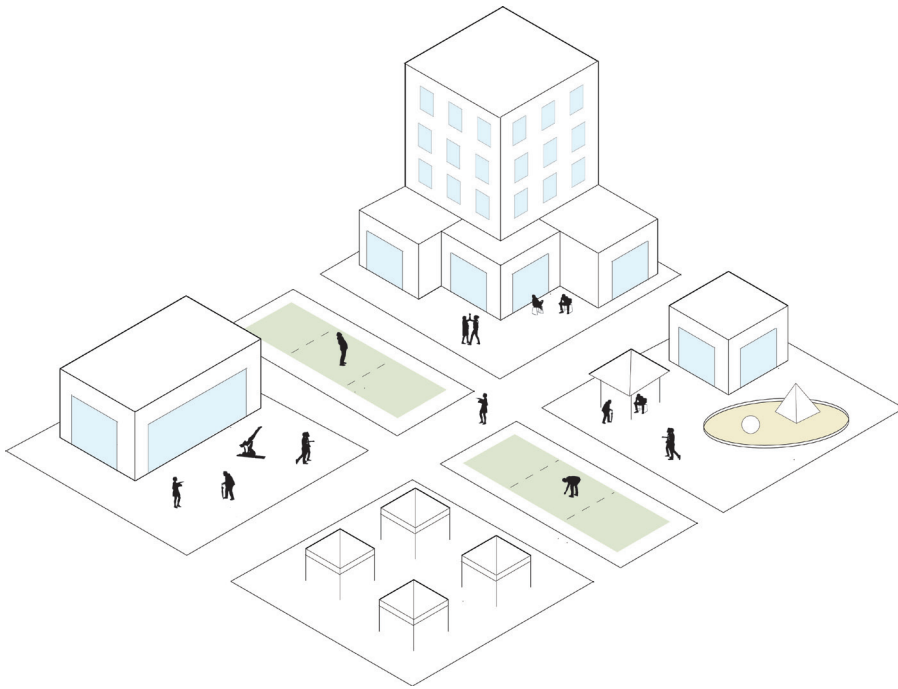

Image 38: Proposed Decentralized Site Strategy

this the Beacon Hill Food Hub will use the the proposed expanded food hub program, consisting; production, distribution, market, dining, and community services.

While this expanded food hub model forms the basis of the program, studies done by Seattle's Department of Neighborhood help strengthen the program to meet the desires of the Beacon Hill Community.(Image 37) The desires vocalized by the community not only support the need for a neighborhood food

hub but refines the program to include micro retail, housing, growing space, and a food incubator. The intent of providing a food incubator within the food hub is to address the communities desire for access to training and resources, in order to develop their own culinary products of businesses. By adding these programs to the basic design of a food hub users are encouraged to engage with regional food production on multiple scales.

Since the food hub is intended to not only be a hub for regional food production but also of social engagement the proposed strategy for the food hub design must encourage multiple opportunities for social interactions. In order to achieve this I propose that the program for the food hub be spread across an urban landscape, allowing for social interactions to occur between these spaces.(Image 38) This strategy not only strengthens social engagement but it also reflects a similar notion of the neighborhood food hub that a decentralized system allows for personalized engagement with the surrounding community.

End Notes

- 22 Kevin Morgan and Adrian Morley, "Re-localising the Food Chain: The Role of Creative Public Procurement" (Report, The Regeneration Institute, Cardiff University, 2002).
- 23 King County, "King County Agriculture Program," http://psrc.org/assets/5652/rfpc_021111_king_ag_program.pdf, 9.
- 24 Snohomish Agriculture Economic Development Action Team (SAEDAT) "A Community Vision for Sustainable Agriculture in Snohomish County, Executive Summary,"
- 25 US Department of Agriculture 2007 Census of Agriculture, "Washington State and County Data," 2007, http://www.agcensus.usda.gov/Publications/2007/Full_Report/Volume_1,_Chapter_2_County_Level/Washington/wav1.pdf
- 26 King County, "FARMS Report," vi.
- 27 "USDA Defines Food Deserts | American Nutrition Association." USDA Defines Food Deserts | American Nutrition Association. American Nutrition Association, Web. <http://americannutritionassociation.org/newsletter/usda-defines-food-deserts>.

Chapter 4 : Foulee Food Hub

As an existing site of food culture within the Beacon Hill community, the goal of this thesis is not to alter the identity for the neighborhood, but rather use the development of a food hub to build upon the neighborhoods existing character. As previously stated the Beacon Hill neighborhood is a cultural diverse community, and while it is the goal of this food hub to provide access to regional food products to all within the neighborhood residents from the Chinese and Pilipino communities have a stronger influence over this site. This influence is reflected in the name for the neighborhoods food hub, The Foulee Food Hub, which takes its name from a Chinese/Pilipino supermarket currently on the site. By connecting the existing identity of the site with the proposed design the food hub better reflect the community it will serve. The following urban and architectural design strategies illustrate how the Foulee Food Hub uses food and architecture to create a place specific design that promotes connections to the social and regional food system within the Beacon Hill neighborhood.

Four Corners

The proposed site for the Foulee Food Hub consists of the four corner sites located at the intersection of Beacon Ave S and S Columbian Way. The intention of choosing these four sites was to leverage their ability to work as individual units or together as a whole. When the sites are joined together they established a zone for the food hub, highlighted in grey. (Image 39) This allows the food hub to operate as a single entity during special events in the community and reclaim the street as a public right-of-way. While this design optimizes the urban space for community events, it also allows for pedestrian-friendly activity throughout its daily use.



Image 39: Four Corner Sites of the Foulee Food Hub

Infrastructure

In order to realize the food hubs potential of being a pedestrian friendly zone that can be closed for neighborhood events alterations to the public infrastructure are proposed. (Image 40) Currently, the proposed site gives dominance to the car. Beacon Ave S consists of two, one-way single-lanes divided by a parking median, and S Columbian Way is a two-way double lane road. Based on studies provided by the Seattle Department of Transportation both Beacon Ave S and S Columbian Way receive a similar 15,000 cars per annual traffic week (5 days/24 hours)³¹ Though this volumes of cars is not untypical of neighborhood arterial streets in Seattle the intent of this proposed design is to restrict the flow of cars within the Foulee Food Hub zone and give dominance to the pedestrian. In order to achieve this I propose that S Columbian Way be narrowed from a two-lane road each way to a single lane, and propose that sidewalks and curb cuts be extended. These two changes would provide more room for pedestrian flows and limit the distance of cross walks pedestrians would use to traverse the site. In addition, I propose that the existing parking median along Beacon Ave S be transformed into

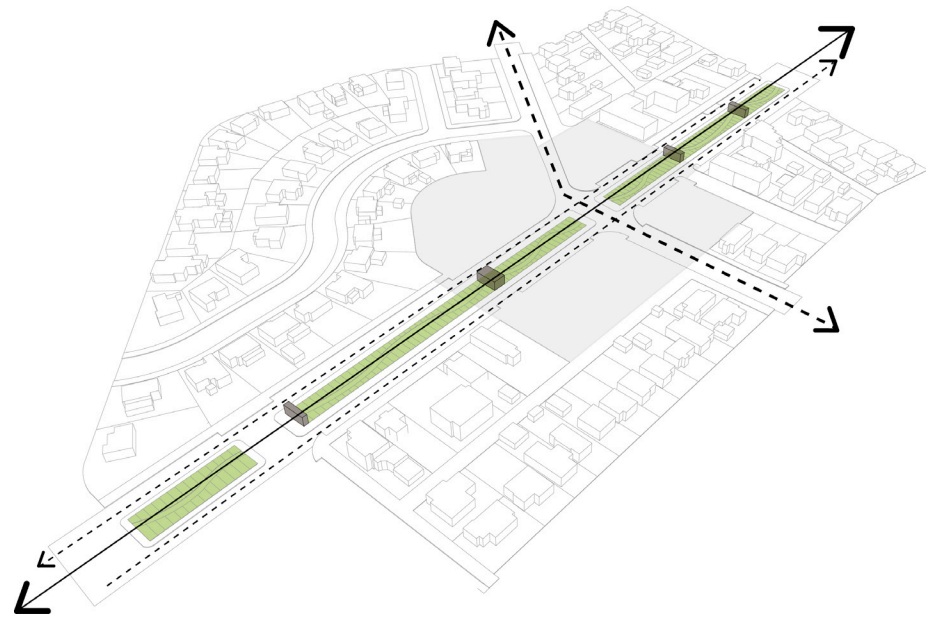

Image 40: Proposed Infrastructure Improvements

a growing median. This shift in use of the public realm allows space for more public p-patches desired by the community. Establishing the growing median also allows for the existing bike path, which currently ends just south of the proposed food hub site, to be connected with Jefferson Park, just north of the proposed site. Finally, small pavilions would be placed along the growing median at major crosswalks, providing pedestrians a place of shelter for food storage, tool stations, and social engagement.

Ground Floor

Since the intent of the food hub is to connect consumers with regional produce and encourage social engagement it is important that the ground floor encourage community interaction. One strategy to encouraged interaction is to pull apart the volumes on the ground floor.(Image 41) Doing so allows for multiple pedestrian routes between the food hub and neighborhood beyond.(Image 42) It should also be noted that not only should the forms encourage interactions but the treatment of these spaces and their facades should promote a transparency between program and pedestrian.

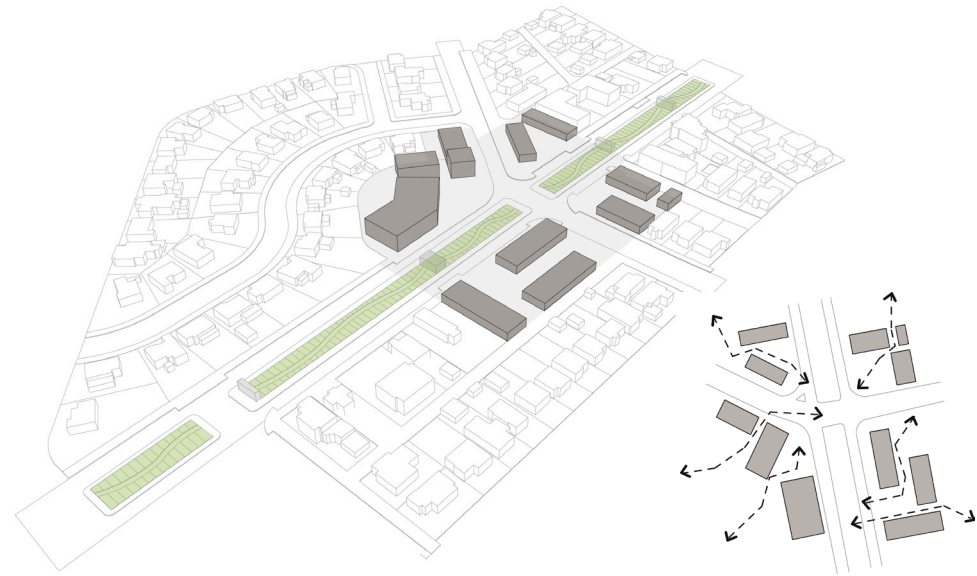

Image 41: Ground Floor Strategy

Image 42: Community Connections

Housing

While providing housing within the food hub will provide much desired housing by the community, it also allows for the design to reinforce the hub as a place within the community. (Image 43) The housing helps to identify the hub by defining a distinct space in which the activities of the hub occurs. (Image 44) It is also the intent of the housing to reinforce social engagement within their individual sites as well as between sites.

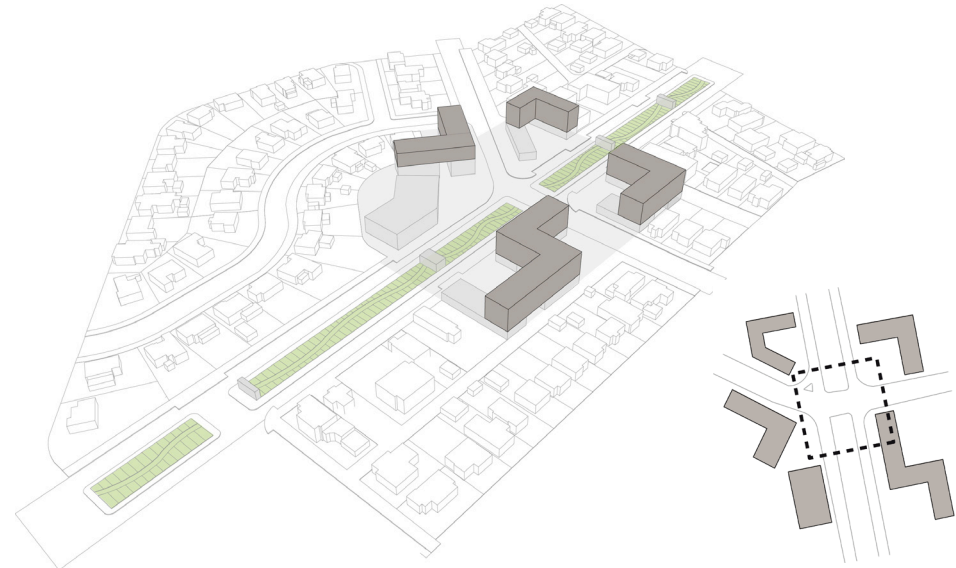

Image 43: Housing Strategy

Image 44: Food Hub Reinforced

Social Engagement

Since the thesis proposes that a neighborhood food hubs allows for social engagement to once again be a part of urban food centers the design fosters urban social engagement on multiple scales. Much like the four corner sites allow for the sites to work individually or as a whole it also allows for social interactions on the individual or neighborhood scale.(Image 45) The proposed alterations to the site infrastructure encourages social engagement at the neighborhood scale by encouraging pedestrian traffic to dominate the site, and even allowing the neighborhood to take over the street for special events.(Image46) Pulling apart the ground floor, and reinforcing the area of the food hub with housing, creates a neighborhood node that allows residents to engage with the site at their convenience and explore something new along their way. Finally creating a diverse space that brings multiple programs and users together, local resident and vendor alike are encourages to engage with one another.

Corner Sites

When approaching the design for the four corners of the Foulee Food Hub it was my intent for one of the corners to serve

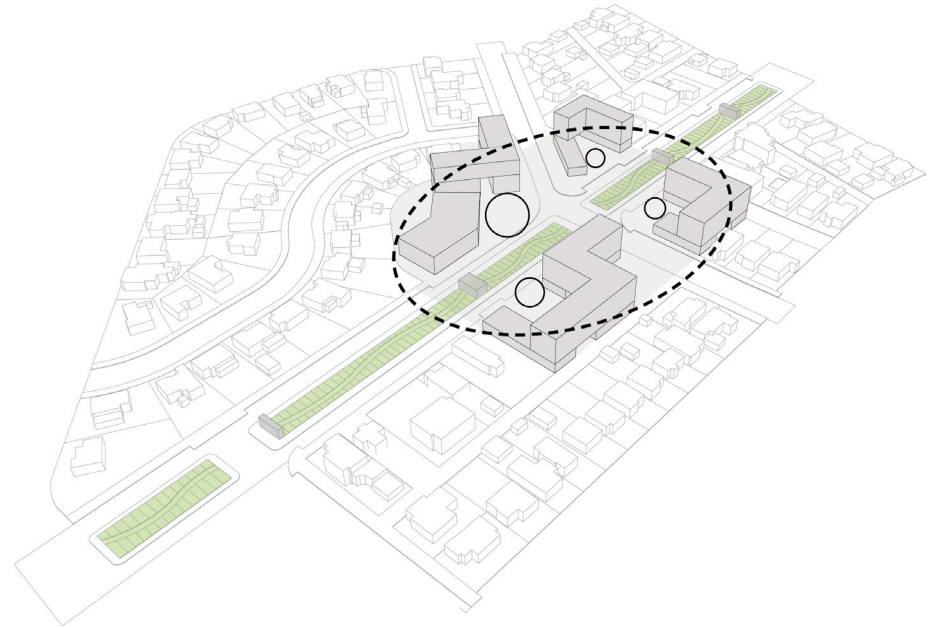

Image 45: Strategy for Social Engagement

as the main site of a market and supporting programs while the three other corners provided space for growth within the market and community. The central market is located on the Southwest corner, while the supporting programs are located on the Northwest, Northeast, and Southeast corners. While the market will develop a distinct typology the three corners share a similar typology. This will include retail and support services for vendor and residents on the ground floor and three floors of housing above . To provide the future residents of the



image 46: Foulee Food Hub during Neighborhood Event

food hub with access to more growing space these three corners contains p-patches, both in the growing courtyard and on the roof, and vertical growing on the housing. To optimize the potential of growing onsite, p-patches are always located to the southern edge of each corner. Similarly growing walls are also always located on sothern facades. To allow for greater solar gain housing has been removed from the southern edge of each site. Though the three corners share a similar typology they all provide their own quality of space and opportunity for exchange within the community.

Northwest Corner Site

With it's location resting between the Market Corner to the South and the VA Medical center to the North, the Northwest corner of the Foulée Food Hub has the potential to see a consistent pedestrian flow throughout the day. Providing retail opportunities along this pedestrian routes promotes exchanges between vendors and local consumers.(Image 47) This site also provides a unique opportunity of engagement with the

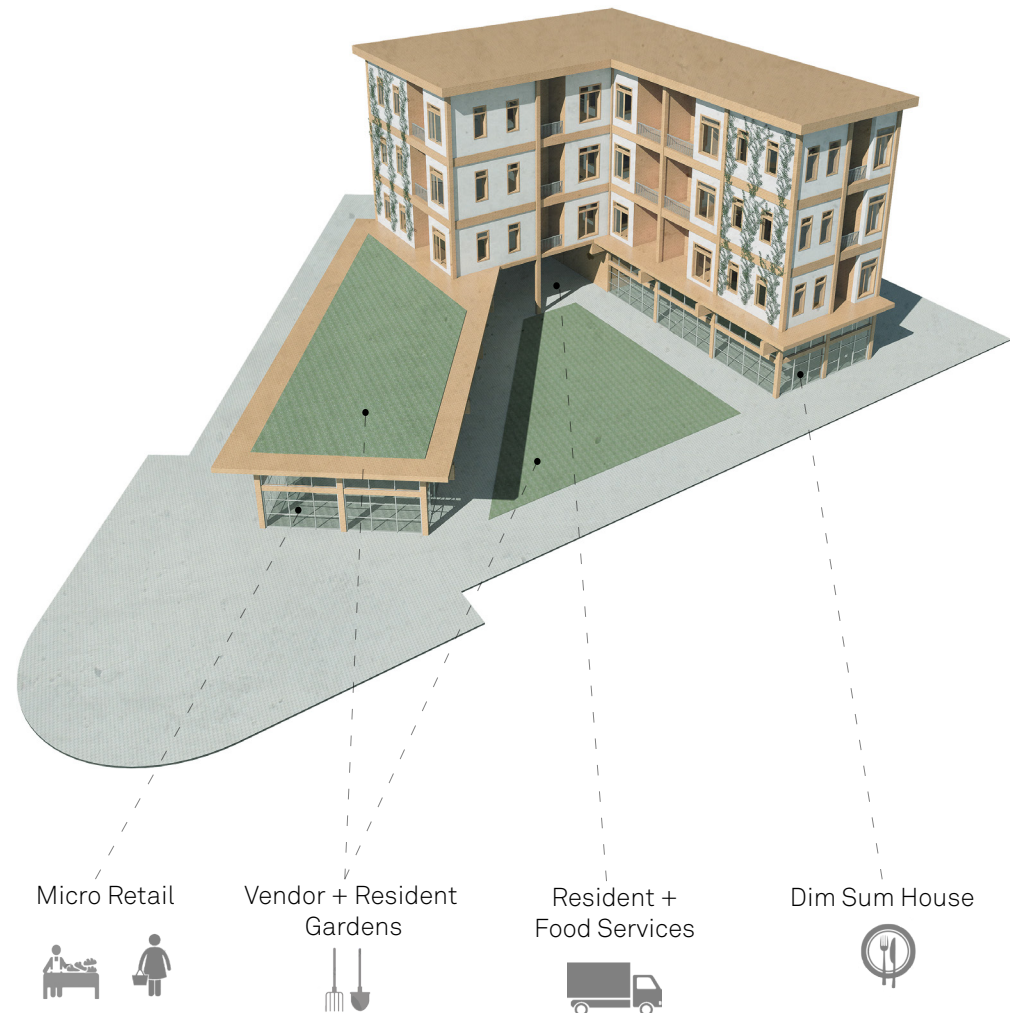

Image 47: Design and Programs for Northwest Corner Site



Image 48: Northwest Corner Site During the Day

the community by providing space for a Dim Sum House. As a much-desired amenity by the existing community I imagine that this new dining space would be particularly popular during the lunch rush for both those visiting the neighborhood and local residents. (Image 48)

Northeast Corner Site

While similar in design the Northeast corner provides opportunity for new social engagement through a community activity center and learning garden (Image 49) Since many of the families in the neighborhood are multigenerational providing places of activates for everyone in the family, particularly the children and elders of the family, is of great benefit to the community. In order to provide a convenience of use for the residents the child and elder care center was located on this corner so that it was on the major bus route used by the community. This location would allow the care center to become part of the families every day routine, particularly become a hub of activity in the mornings as parents drop their little-ones off

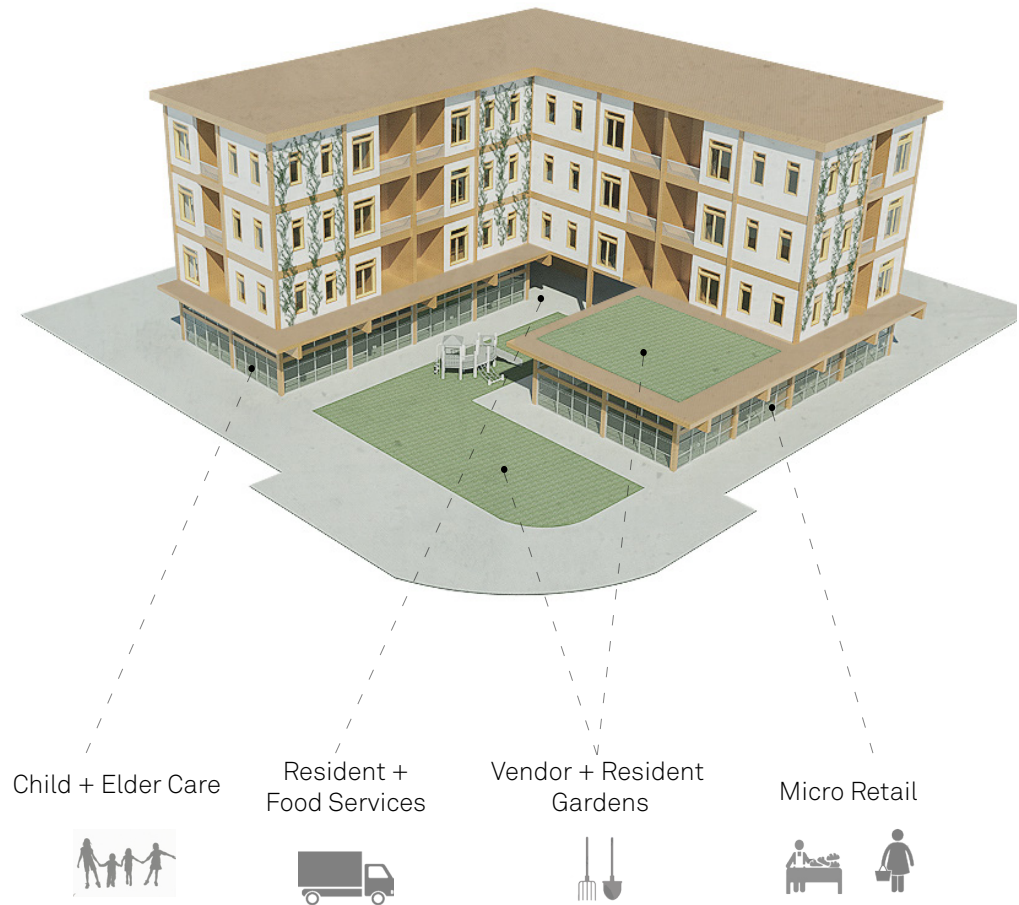

Image 49: Design and Program for Northeast Corner Site



Image 50: Morning at Northeast Corner Site

before grabbing a quick bite and heading into downtown for work. (Image 50)

Southeast Corner Site

The southeast corner, being the largest of the three corner sites provides the hub with the greater ability to grow and further engage with the community. (Image 51) Having a more expansive site, this corner provides larger growing courtyard space than those found in the other corner sites. These larger area and the fact that they are directly linked to the sidewalks encourage these spaces to be used by the public. The retail that surrounds the growing courtyards also promotes a connection with the vendors on site. These connections provide a space similar to that of a Biergarten, promoting the consumption of local food within an outdoor space. This unique space also provides a public social space that promotes the food hub as a center of activity by extending its hours of use into the evening. (Image 52)

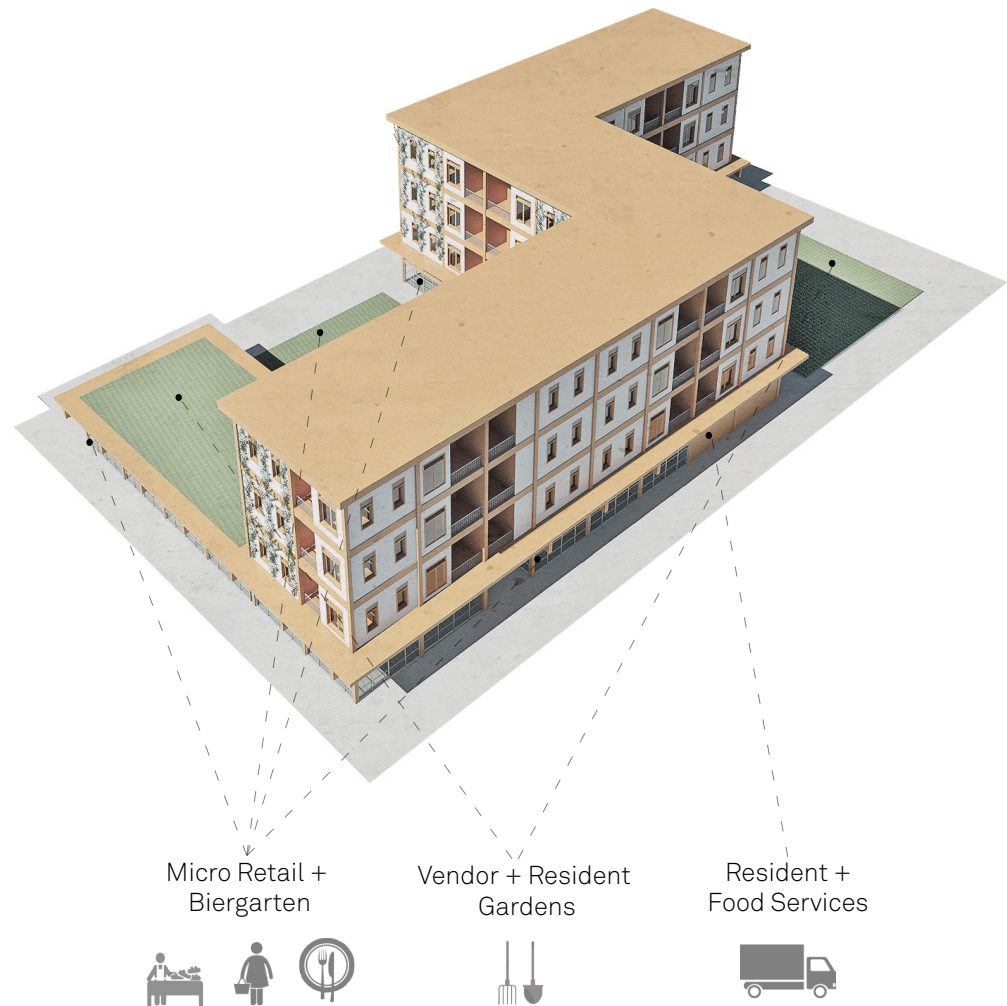

Image 51: Design and Program for Southeast Corner Site



Image 52: Evening in the Biergarten

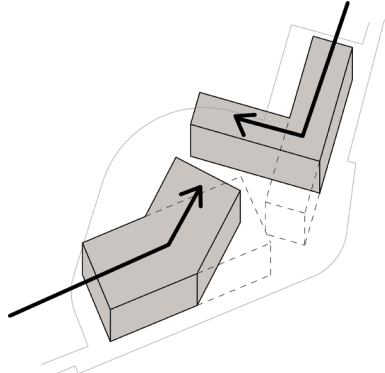

Image 53: Bent Form

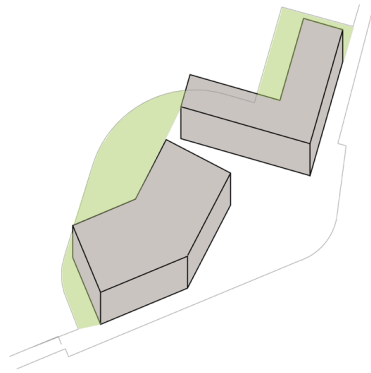

Image 54: Public Growing

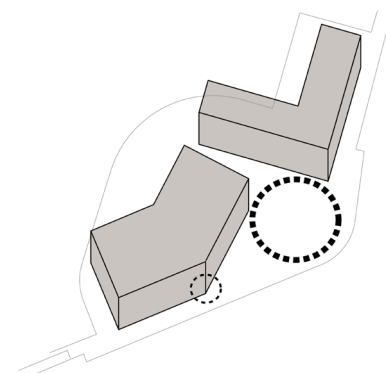

Image 55: Social Engagement

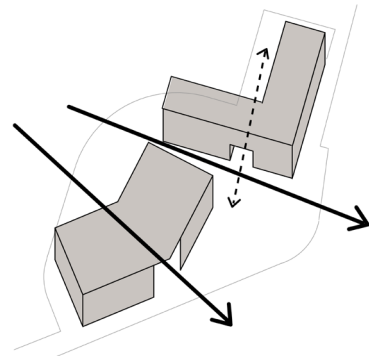

Image 56: Community Connections

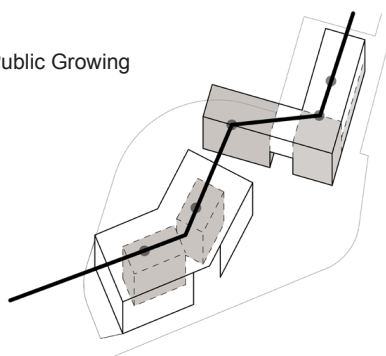

Image 57: Connection of Production

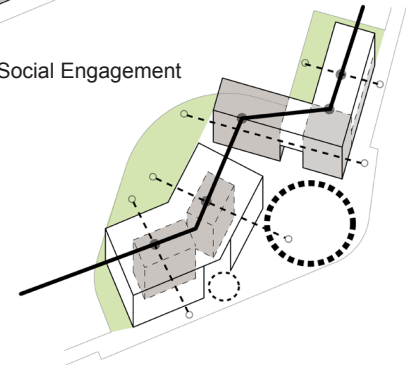

Image 58: Interconnection of Program

Market + Food Incubator

As the center of food and social engagement within the hub the design of the market and food incubator corner shares an architectural language with the other three sites but ultimately engages with its site in a unique way. While the ground floor spaces within the other three sites, front the public right-of-way and define a shared public space, the intention for the market site was to have the forms bend and create public space. (Image 53) By bending the main volumes on the site a public

on the site a public growing space is defined at the southern edge of the site (Image 54), while a multitude of public gathering spaces are created along the edge of the public right-of-way. (Image 55) Just as the proposal for the ground floor volumes promote connections to the community beyond, voids within the bent forms of the market allow for connections through the site to the community. (Image 56) Since the Market and Food Incubator are not only a place of social engagement but also a place to engage with the regional food system, production pods spread

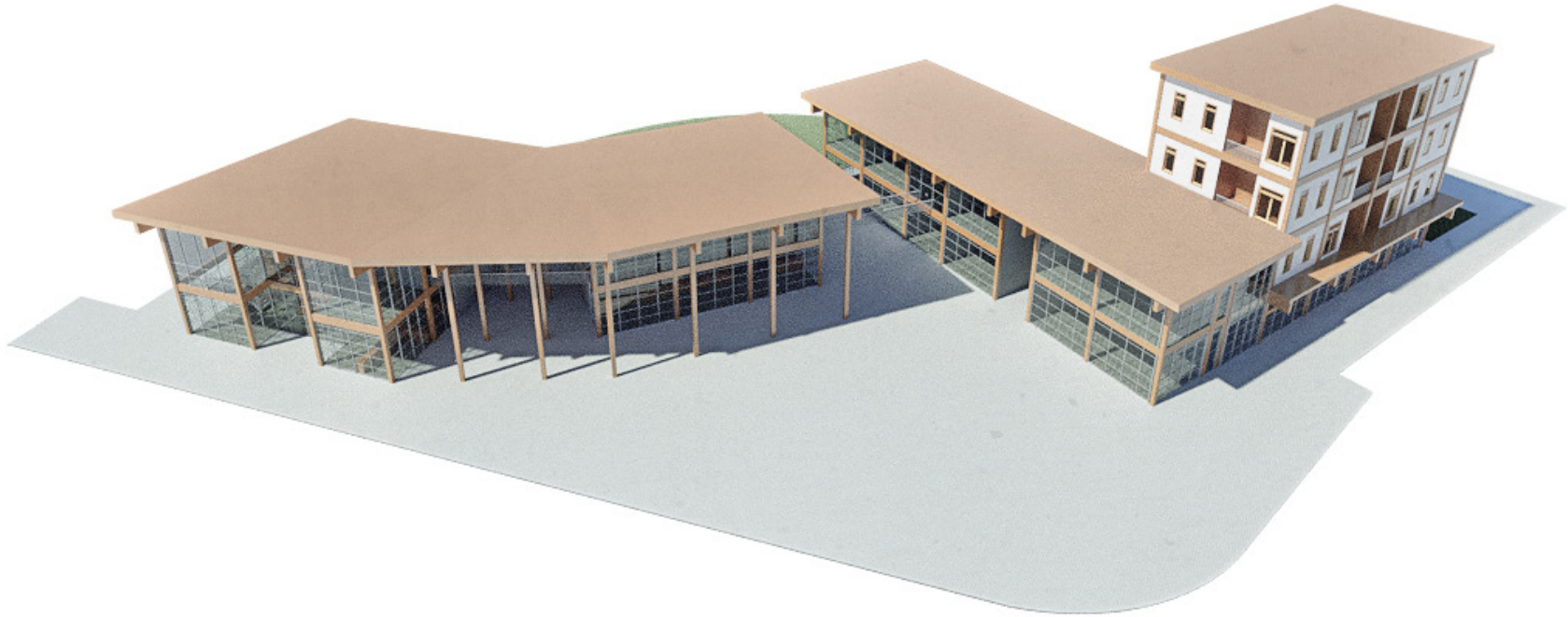

image 59: Design of Market and Food Incubator Corner

throughout the different spaces of the site establish a like between these spaces.(Image 57) The form and layout of program within the market and food incubator work together to support an engagement between social and regional food system. (Image 58)

Architectural Treatment

While the micro retail and the housing along the northwest edge

of the site corner, reflects elements found in the other three corners, the market and food incubator offer a new typology within the food hub. (Image 59) Though public space is limited to the ground floor on the other sites, the Market and Food Incubator both offer two floors of public space. These two public buildings are situated around the public plaza, not only encouraging pedestrian interaction with the two buildings but also establish a greater connection between these two spaces.



Image 60: The Plaza at the Market and Food Incubator Corner

By establishing these spaces as part of a larger public space allows for the Market and Food Incubator to become a hub of activity, all which occurs around the public plaza. (Image 60) This connection is further enhanced by the fact that both volumes are treated with glazing systems, allowing the user to have a visual connection within and between these spaces. It should also be noted that heavy timber, and CLT construction is proposed throughout the Food Hub. This is done to establish an architectural character between the four sites of the food hub, but also to create a relationship between the food hub and the greater region. By using timber-based products the food hub not only supports local food systems within the Seattle region, but also supports the timber industry within the region. These choices for the architectural treatment of a neighborhood food hub support these spaces as a place of engagement to social and regional food systems.

Laying Out the Market + Food Incubator

Just as the form of the market and food incubator support engagement between the public and regional food system, so does the interior layout of program between the two spaces. (Image 61) The Market, located at the Southeast corner of the site, consists of two formal interior retail spaces. An exterior space for sits between the two interior spaces, providing room for

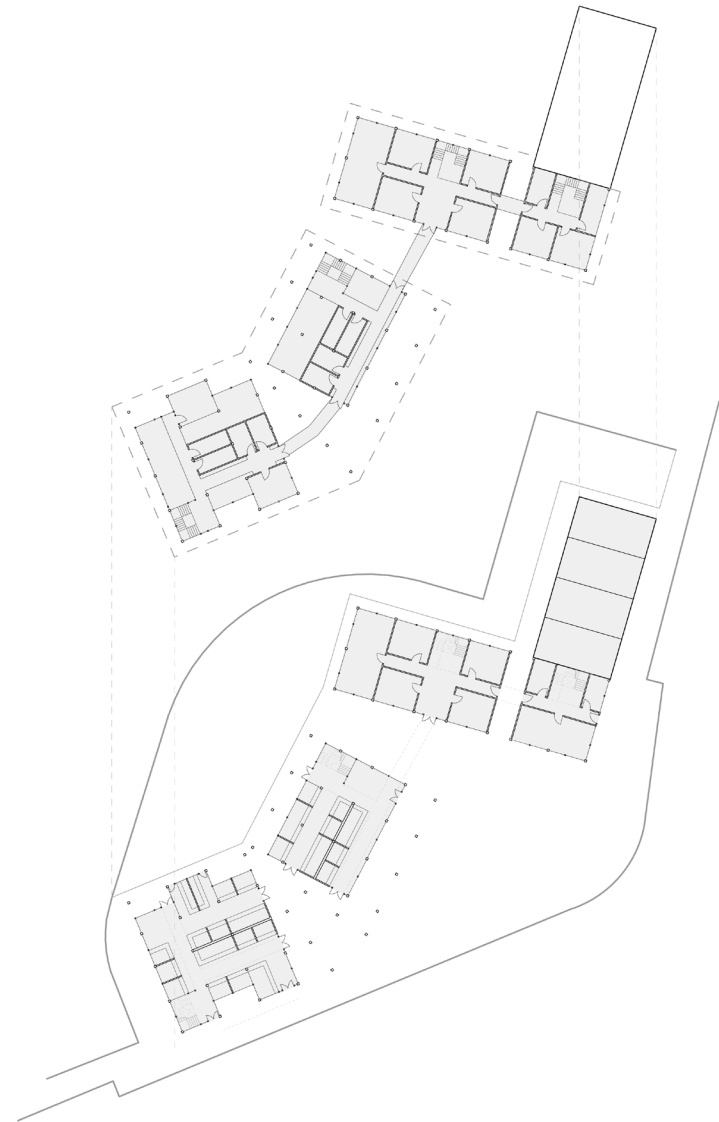

Image 61: Floor Plan of Market and Food Incubator Corner

informal markets and exterior dining. These three spaces are housed under one roof, which defines a canopy for the market space. Within the market spaces there are a mix of retail stalls on the ground floor, providing space for a variety of regional vendors. At opposite ends of the market there are opportunities to reach the floor above, which contain productions and storage pods. Connecting the pods on the second floor is a hanging walkway, which provides circulation space for vendors to transport raw produce for processing, packaging, and retail. This walkway not only connects the pods within the market but also provides a connection, across the plaza, to the food incubator.(Image 61)

Though the food incubator does not provide space for retail, social engagement is still an important factor in how the space operates. Being the center for neighborhood business development, the food incubator provides a place for local residents to obtain the knowledge and resources needed in order to develop their own food-based products. To engage the community the food incubator provides space for shared commercial kitchen, food storage, packaging resources, and community classrooms. A mix of these programs are found on the ground and second floor of the food incubator. The spaces are connected by interior hallways, allowing the active spaces to occur on the exterior of the space, creating a connection to the site beyond.

Having this connection not only allow users a view out into the food hub, but also allows pedestrians to view into these spaces. This transparency supports a connection between local residents and the processes that create regional food products.

Using the Market + Food Incubator

Much like the three corner sites the Market and Food Incubator is designed to encourage activity throughout the day by mixing programs and spaces.(Image 62) Starting in the early morning vendors and residents begin their days in the garden and plaza. As gardens tend to their crops in the p-patches, delivery trucks begin to assemble in the plaza, both getting the needed produce ready for the day's business. As fresh produce is brought in for the day vendors sort through the deliveries storing the excess and processing the rest for sale. While vendors begin their production for the day and early rush of customers roll into the market for a quick morning bite. After the early morning rush the Food Incubator opens for the day. Classes are provided throughout the day and evening to meet the schedule of the local residents. Shared facilities such as commercial kitchens and packaging rooms are available daily for rent. This flexible space sees a variety of uses throughout the week and year as the community changes. Finally, dining and retail spaces



image 62: Program Layout of Market and Food Incubator Corner Use

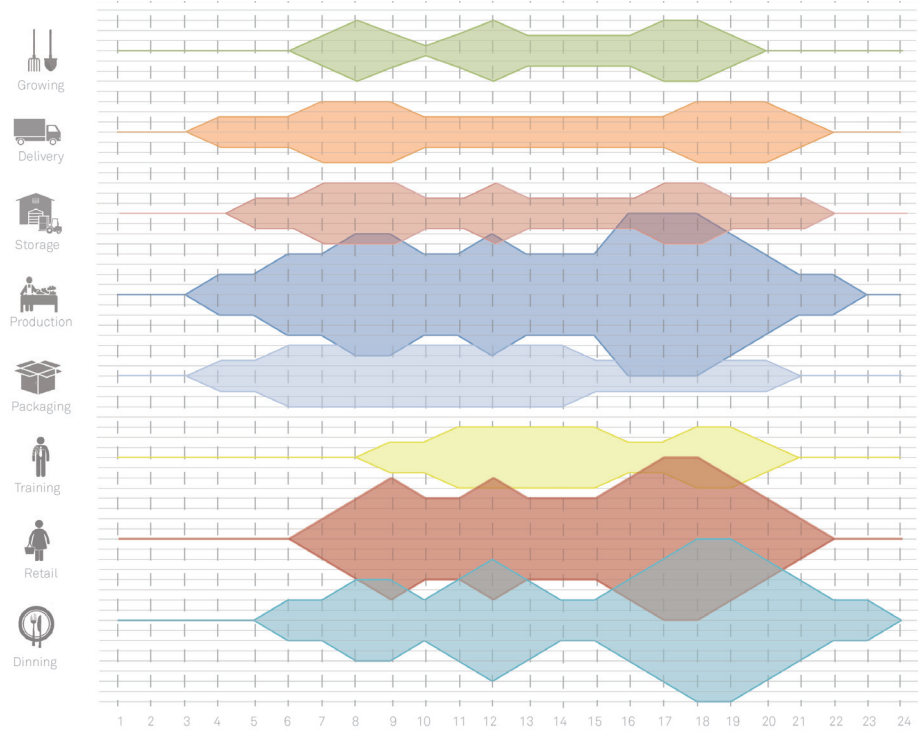

Image 63: Timeline of Market and Food Incubator Corner Use

End Notes

- 28 Wilma, David. "Seattle Neighborhoods: Beacon Hill -- Thumbnail History." HistoryLink.org- the Free Online Encyclopedia of Washington State History. N.p., 21 Feb. 2001. Web. http://www.historylink.org/index.cfm? DisplayPage=output.cfm&file_id=3004.
- 28 Tobin, Caroline. Beacon Hill Historic Context Statement. Seattle: City of Seattle Department of Neighborhoods, May 2004. PDF.
- 29 Statistical Atlas. Web, <http://statisticalatlas.com/neighborhood/Washington/Seattle/Beacon-Hill/Overview>
- 30. Tobin, Caroline. Beacon Hill Historic Context Statement. Seattle: City of Seattle Department of Neighborhoods, May 2004. PDF.
- 31 Seattle Department of Transportation "Traffic Flow and Data Map – 2014" Web <http://www.seattle.gov/transportation/tfdmaps.htm>



Image 64: Exterior View of Market



Image 65: Section of Market

in the market and along the street, provide the community with the opportunity to socialize and consume into the evening hours. The diverse program and layout of the market and food incubator encourage a variety of users to engage with the site throughout the day. (Image 63)

The Market

As the heart of regional food production and social engagement within the Foulée Food Hub, the market must serve to connect a variety of users and needs of those who support the regional food system, as well as be a desirable space for the local community to socialize. (Image 64)

The design of the market consist of a central core, which houses important spaces for food production. A flexible retail space surrounding the core, serves as a fluid space for the changing markets of the community. Finally, exterior community flex spaces, along the garden and public right-of-way, encourage informal public engagement. (Image 65) The production core, the retail space, and external community space support the market as a physical connector between the community, social engagement, and regional food systems. (Image 66)



Image 66: Interior View of Market

Chapter 5: Conclusion

The typology for a neighborhood food hub, presented by the design of the Foulee Food Hub, provides a beginning approach for designing a neighborhood food hub the proposal could only be strengthened by further development. One of the fields in which the project could be strengthened is in resource flow within the food hub and community. The benefit of developing production flows would further show how the food hub engages with the regional food system. By refining how resources flow would also develop the architectural relationships between the element on the site and the individual needs of each space.

It should be stated that this thesis is not purely one of architecture; rather the scale of the proposed project explores the fringe between architecture and the urban environment. While this thesis seeks to address the relationships between the urban experience and architectural express of the regional food system within and urban community, both scales of the project require refinement. Development of both the urban and architectural scale would allow for opportunities to further engage the specific site and community surrounding the

proposed food hub. This refinement would also provide the opportunity to establish a series of design strategies for the urban and architectural design of other neighborhood food hubs.

This thesis also creates opportunity for further study on how food and architecture can provide opportunity for social engagement; one of the most compelling being the study of how the pedestrian can reclaim the street, particularly through informal markets. Part of the proposal for this food hub required alterations to the street infrastructure in order to provide more space for the public right-of-way. This provides opportunity to further study how the design of streets could be altered to provide infrastructure for informal markets, allowing local residents to democratize the public realm.

Work Cited

“About the Wedge.” Wedge Community Co-op. Web. <http://www.wedge.coop/about-the-wedge/>.

Franck, Karen A. “The City as Dining Room, Market and Farm.” *Architectural Design* Archit Design 75.3 (2005): 5-10. Web.

“History.” Lexington Market. *Hardly Square*, n.d. Web. <http://lexingtonmarket.com/history/>

Jim Barham, “Regional Food Hubs: Understanding the scope and scale of food hub operations” (2011).

Kevin Morgan and Adrian Morley, “Re-localising the Food Chain: The Role of Creative Public Procurement” (Report, The Regeneration Institute, Cardiff University, 2002).

King County, “King County Agriculture Program,”. Web. http://psrc.org/assets/5652/rfpc_021111_king_ag_program.pdf, 9.

King County, “FARMS Report,”. Print.

Know Your Farmer, Know Your Food Regional Food Hub Subcommittee, (Presentation). <http://www.ams.usda.gov/AMSV1.0/getfile?dDocName=STELPRDC5088011&acct=wdmgeninfo>

Rosenfield, Karissa. “OMA Designs Food Port for West Louisville.” *ArchDaily*. Plataforma NetworksPlataforma Networks, 22 Feb. 2015. Web.<http://www.archdaily.com/601730/oma-designs-food-port-for-west-louisville>

Seattle Department of Transportation “Traffic Flow and Data Map – 2014” Web <http://www.seattle.gov/transportation/tfdmaps.htm>

Snohomish Agriculture Economic Development Action Team (SAEDAT) “A Community Vision for Sustainable Agriculture in Snohomish

Statistical Atlas. Web, <http://statisticalatlas.com/neighborhood/Washington/Seattle/Beacon-Hill/Overview>

Steel, Carolyn. *Hungry City: How Food Shapes Our Lives*. London: Chatto & Windus, 2008. Print.

Tobin, Caroline. *Beacon Hill Historic Context Statement*. Seattle: City of Seattle Department of Neighborhoods, May 2004. PDF.

United States Department of Agriculture "Regional Food Hub Resource Guide" Web. <https://www.ams.usda.gov/sites/default/files/media/Regional%20Food%20Hub%20Resource%20Guide.pdf>

United States Department of Agriculture 2007 Census of Agriculture, "Washington State and County Data," 2007, http://www.agcensus.usda.gov/Publications/2007/Full_Report/Volume_1,_Chapter_2_County_Level/Washington/wav1.pdf

"USDA Defines Food Deserts | American Nutrition Association." American Nutrition Association, Web. <http://american nutritionassociation.org/newsletter/usda-defines-food-deserts>.

