

Process, Symmetry, and Neo-Classicism in the 20<sup>th</sup> Century: Three analytic essays.

Matthew Szwyd

A thesis  
submitted in partial fulfillment of the  
requirements for the degree of

Master of Arts

University of Washington  
2015

Committee

Jonathan W. Bernard

Joël-François Durand

Program Authorized to Offer Degree:

Music

©Copyright 2015  
Matthew Szwyd

University of Washington

**Abstract**

Process, Symmetry, and Neo-Classicism in the 20<sup>th</sup> Century: Three analytic essays.

Matthew Gordon Szwyd

Chair of the Supervisory Committee:  
Dr. Jonathan W. Bernard  
Music

This thesis comprises three analyses on works from the early, middle, and late periods of the twentieth century. The first chapter uses pitch set analysis, harmonic polarity, and motivic development in order to examine the use of classical form in Anton Webern's *Five Movements for String Quartet*, Op. 5, No. 1 (1909). The work, from Webern's early, pre-twelve-tone atonal period, is a calculated attempt by the composer to, in his own words, "say—in quite a new way—what has been said before." The second chapter examines the concurrent application of both symmetry and the integral values of Christian numerology (three, five, and seven), applied to pitch, time, and rhythm in Olivier Messiaen's *Visions de l'Amen* (1943). The third chapter focuses on the first section of Gerard Grisey's *Talea* (1986), and evaluates the procedures by which Grisey integrates several musical dichotomies as a form-articulating process.

## TABLE OF CONTENTS

|   |     |
|---|-----|
| List of Figures.....  | ii  |
| <b>I.</b> Allusions to Tonal Practice and Classical Form in Anton Webern’s <i>Five Pieces For String Quartet</i> , Op. 5, No. 1.....                | 1   |
| <b>II.</b> <i>Musique Vivante</i> : The Divine Influence on Symmetry, Duration and Cardinality in Olivier Messiaen’s <i>Visions de l’Amen</i> ..... | 37  |
| <b>III.</b> The Homogeneity of Opposition in Gérard Grisey’s <i>Talea</i> .....   | 80  |
| Sources Cited.....  | 116 |

## LIST OF FIGURES

### I. Allusions to Tonal Practice and Classical Form in Anton Webern's *Five Pieces For String Quartet, Op. 5, No. 1*

| Figure  | Page |
|---|------|
| 1. Formal layout of possible sonata form model. ....                                | 9    |
| 2. Discrete “fragments” that constitute the A section, mm. 1–6. ....                | 10   |
| 3. Inversion of (0145) tetrachord over 0/1 – 6/7 axis. ....                         | 13   |
| 4. Symmetrical transposition of stretto entrances. ....                             | 14   |
| 5. Set class composition of the second theme, mm. 9–13. ....                        | 16   |
| 6. Completion of chromatic aggregate at the end of Theme 2. ....                    | 17   |
| 7. The two constituent parts of the B motive. ....                                  | 18   |
| 8. Transposition of “tail” set in stretto, mm. 13–15. ....                          | 19   |
| 9. Combined wedge-shaped statements in violin 1. ....                               | 20   |
| 10. Contracting wedge-shaped contour, mm. 19–22. ....                               | 20   |
| 11. Wedge and tail sets of B motive return, violin 1, mm. 36–38. ....               | 21   |
| 12. Return of B section materials, mm. 36–42. ....                                  | 22   |
| 13. Defining characteristics of the C, or development, section. ....                | 25   |
| 14. Set class composition of second stretto during retransition to A' section. .... | 26   |
| A. mm. 46–47; articulations removed. ....   | 26   |
| B. mm. 46–47; stretto realigned. ....   | 27   |
| 15. Melodic retransition into the recapitulation section. ....                      | 28   |

|   |    |
|---|----|
| 16. Transposition of (02345679) octachord across hemispheres<br>of the mod 12 clock. ....                                       | 30 |
| A. Pitch distribution around both poles of the 0/1 – 6/7 axis,<br>mm. 49–55. ....   | 30 |
| B. Pitch distribution around the mod 12 clock. ....   | 30 |
| 17. Pitch class distribution around one end of 0/1 – 6/7 axis, in T <sub>0</sub> hemisphere<br>of the mod 12 clock, m. 55. .... | 32 |
| 18. (014) trichords arranged in both (0145) and (0347) tetrachords. ....  | 32 |
| 19. Reduction of chords, mm. 1–55. ....   | 34 |

## II. *Musique Vivante*: The Divine Influence on Symmetry, Duration and Cardinality in Olivier Messiaen’s *Visions de l’Amen*

| FIGURE   | Page |
|--|------|
| 1.1. Non-retrogradable rhythmic modules in “Amen de la Création.” .....              | 44   |
| 1.2. The creation theme, mm. 9–16. ....  | 46   |
| 1.3. Rhythmic modules (piano 1) and creation theme (piano 2). ....                   | 46   |
| 1.4. Background structure of the rhythmic modules in “Amen de la Création.” ..       | 49   |
| 1.5. Linear displacement of juxtaposed <i>taleae</i> , or phases, of the canon. .... | 51   |
| 2.1. “Amen de la Création,” piano 1, reduction of <i>color</i> in both hands. ....   | 52   |
| 2.2. Aspects of the talea phase. ....  | 53   |
| A. Base rhythm of the rhythmic canon. ....   | 53   |
| B. The rhythmic canon, first phase, “Amen de la Consommation,”<br>mm. 1–2. ....      | 54   |

|   |    |
|---|----|
| 2.3. “Amen de la Consommation,” left hand rotations beneath first color collection in piano 1, mm. 38–52. ....                                    | 55 |
| 2.4. “Amen de la Consommation,” reduction of left hand rotations beneath right hand <i>color</i> of piano 1 in each phase of rhythmic canon. .... | 55 |
| 3.1. “Amen de la Création,” thematic development. ....  | 57 |
| 3.2. Thematic development in “Amen de la consommation.” ....  | 61 |
| 4.1. Temporal structure implied by three underlying X modules, mm. 97–175. ..   | 68 |
| 4.2. Pitch reduction of the carillon ostinato, mm. 97–130. ....   | 68 |
| 5.1. Motivic fragments that constitute the “theme of the dance of the planets.” ..  | 70 |
| 5.2. Fragments in order, constituting a phrase (“phrase C” in figure 5.3), mm. 19–23. ....  | 71 |
| 5.3. “Amen des Étoiles, de la Planète à l’Anneau,” symmetrical phrase design... ..  | 73 |
| 6.1. Symmetry in the theme titled, “the affliction of the Father.” ....   | 75 |
| 6.2. Gestural symmetry in the theme titled “the tears of Jesus in his agony.” .....   | 76 |

### III. The Homogeneity of Opposition in Gérard Grisey’s *Talea*

| FIGURE   | Page |
|--|------|
| 1. P.A. Castanet’s table of opposing forces in the music of Grisey. ....       | 86   |
| 2. The dichotomies of <i>Talea</i> . ....                                      | 88   |
| 3. Proportions of distinct materials in each cycle in the piano. ....          | 90   |
| A. Length of piano cycles 1–16, with ratio of constituent materials. ....      | 90   |
| B. Numerical data for figure 3a. ....  | 91   |
| 4. Sketch of the first section of <i>Périodes</i> . ....                       | 92   |
| 5. Arrangement of instruments on stage, reprinted from the performance notes.. | 93   |

|   |     |
|---|-----|
| 6. Proportional layout of cycles 1–17 against original voice (piano),<br>Section I. ....  | 94  |
| 7. Inception of first polyphonic voice by the violin and cello between<br>rehearsal nos. 3 and 4; no A material present. ....                                       | 96  |
| 8. Assignment of instruments to the five polyphonic voices in<br>Section I of <i>Talea</i> . ....   | 97  |
| 9. Similar gestures labeled “très rythmé” that occur in each instrument,<br>arranged in the order they occur. ....  | 98  |
| 10. Symmetrical arrangement of polyphonic voice generation reflected by<br>the position of instruments on stage. ....   | 99  |
| 11. Rehearsal nos. 11–16, length of cycles in each voice; cycles realigned<br>according to simultaneity; durations measured in quarter notes. ....                  | 100 |
| 12. Method used to calculate total duration of A material in cycle. ....  | 101 |
| 13. Displaced A material as it is slowly eroded into silence. ....  | 102 |
| 14. Contour of the flute and clarinet in voice 2, between rehearsal nos. 6–7. ....  | 103 |
| 15. Spectrogram of opening music (excerpt), with B material accelerations<br>“B,” and decelerations, “A,” annotated. ....   | 105 |
| 16. Subdivisions of the A material in the original voice (piano). ....  | 106 |
| 17. The first 32 tones of the harmonic series based on C <sup>1</sup> , rounded to the<br>nearest eighth of a tone. ....  | 107 |
| 18. Pitch content of the A material in the first three cycles of voice 1,<br>all instruments. ....  | 109 |
| 19. Segments of the overtone series outlined at the onset of voices 2 and 3. ....   | 110 |
| A. Upper partial content of the flute immediately before rehearsal<br>no.7, with corresponding tones of the overtone series. ....                                   | 111 |
| B. Voice 2: violin provides tones of the series, while the cello<br>fills in the pitch space, generating inharmonicity (highest<br>partial tones, transposed). .... | 111 |
| C. Voice 3: flute provides tones of the series, while the clarinet<br>generates inharmonicity (highest partial tones, transposed). ....                             | 112 |

|   |     |
|---|-----|
| 20. Pitch content of pre-ostinato “wave” gestures at the end of Section 1,<br>with approximate range of harmonic series tones annotated. .... | 113 |
| 21. Pitch content of the final four cycles of the piano (voice 1) as the partials<br>approach the fundamental tone. ....                      | 114 |

## **ACKNOWLEDGMENTS**

I would like to thank Dr. Jonathan W. Bernard for his countless revisions of my work, his invaluable commentary, and his unequivocal ability to fascinate, astound, and inspire me.

## **DEDICATION**

To Katie, and my loving family, without whom none of this would be possible.

Chapter I:

Allusions to Tonal Practice and Classical Form in Anton Webern's *Five Pieces For String Quartet*, Op. 5, No. 1

Despite his progressive approach, Webern's early prose and compositional process draw many parallels to the forms of Western musical tradition, often articulated through the repetition of familiar gestures and patterns of repeating intervals. Completed in 1909, the *Five Pieces for String Quartet* reflect Webern's early atonal innovations, relying primarily on motivic, thematic and textural relationships in order to supply form in the absence of tonal means. While tonal motion, agitation, and resolution no longer provide harmonic evidence towards the designation of "key areas,"<sup>1</sup> Webern's conscientious development of themes and gestures throughout the composition echoes stylistic idioms rooted in the common practice period—an observation reinforced by the composer's own statement regarding new music: "We want to say—in quite a new way—what has been said before."<sup>2</sup>

This analysis focuses on the first movement of the work, examining the development and manipulation of recurrent motives as a means of articulating form. This approach will be supported by additional examination of pitch relations from a set theory perspective in order to draw connections between motives when factors such as registral displacement, changes in rhythmic profile, and inflections in melodic contour disguise essential collections in a manner that is less apparent to the ear. This same analytic

---

<sup>1</sup> The term "key areas" is used here in reference to modulatory schemes native to common-practice forms that predate the compositions of Webern, yet undoubtedly influenced his organizational procedures as a composer. The transposition of thematic elements, while no longer a tonal concern, promotes a hierarchy of form-articulating pitch levels. Roger Smalley's annotated publication of Webern's sketches reveals Webern's concern for controlled transposition even in his entirely atonal, twelve-tone works. See Roger Smalley, "Webern's Sketches (II)," *Tempo* 113 (June 1975): 29–40.

<sup>2</sup> Anton Webern, *The Path to the New Music*, trans. Leo Black (Bryn Mawr, PA: Theodore Presser Co., 1963), 55. Emphasis in original.

procedure will be applied to harmonic structures, revealing a matrix of set class transformations and formal touchstones.<sup>3</sup>

Many of Webern's compositions have been approached as rounded tripartite forms. The first movement of his *Five Pieces for String Quartet* is, on the surface, a "fractured" ABA' form.<sup>4</sup> That is to say, many of the thematic materials and discrete timbral figments of the A section are scattered throughout the composition while overarching textural articulations divide the composition into three distinct areas of thematic focus. Perhaps the most evident articulation of form is the emphasis placed on the interval of the augmented octave spanning C–C#, which plays an integral role in the overall form of the work—it is the first and final melodic interval of the movement. At the very least, the movement is clearly confined by this interval, which suggests a thematically "rounded" form.

The first movement consists of five pronounced sections, each composed of distinct or developed thematic material. The most conclusive and unambiguous sectional divisions occur at mm. 6 and 13, where fermatas break musical continuity and articulate a division between two parts: the A section, mm. 1–6, and the B section, mm. 7–13, respectively. In mm. 14–49, identifying new sections becomes a thematic matter, one that requires isolating self-sufficient thematic regions from the scattered fragments of the A section. The B' section, in many ways an extension of the previous B section, functions primarily in the service of developing a motive referred to as the "B motive," which is first introduced at the beginning of the B section. Both B sections project a lyrical theme,

---

<sup>3</sup> The transformations referenced here are  $T_n$  operations.

<sup>4</sup> See figure 1.

which shares a similar contracting, wedge-like contour to that of the B motive, but is expanded and further manipulated in a variety of forms. The C section introduces new material and is interrupted by fragments directly from the A and B sections; the homogeneity between the halves, however, provides ample evidence for substantiating an overall “C,” or development, section. The final section of the piece, a partial recapitulation of the A section, presents motivic fragments of the A section while placing emphasis on the opening interval of the piece: the augmented octave C–C#.

This recapitulation of motivic fragments from the A and B sections at the conclusion of the piece suggests an overall tripartite form, such as A – B – A'. While motivic connections throughout the piece allude to the possibility of an underlying sonata-allegro form, harmonic polarity exhibited in the movement's various set class connections suggests an underlying series of harmonic rotations. It is important to dispel any preconceived notions regarding the sonata form model—namely, that it must conform to rather crude “exposition, development, and recapitulation” form that is affirmed by recurring themes that occur either in the tonic or its dominant counterpart. While the arrangement of themes in the first movement may only loosely conform to the basic model of form, the movement as a whole demonstrates the principal objective of the sonata form with regard to the recapitulation of themes:

[T]onality and the thematic process coordinate, for the reentry of the tonic coincides with the return to original material in its approximately original form and order. Moreover, the material formerly heard in the new key now recurs in the tonic, providing a long-range resolution of the tonal tension created by the modulation in the exposition.<sup>5</sup>

---

<sup>5</sup> Don Michael Randel, ed., *The Harvard Dictionary of Music*, 4<sup>th</sup> ed. (Cambridge: Harvard University Press, 2003), s.v. “Sonata Form,” 799.

Here emphasis will be placed on the transposition of previously heard thematic material into a tonic “key” as a means of bringing the formal narrative to a close. Within the overarching sections of this form exists a great deal of versatility, as described by Arnold Schoenberg as “extraordinary flexibility in accommodating the widest variety of musical ideas, long or short, many or few, active or passive, in almost any combination.”<sup>6</sup> To this end, Webern’s departure from the traditional sonata form model does not signify a renouncement of the form as a whole, but rather a reassessment of the many ways the rhetorical goal of the sonata may be expressed.

In the chapter “The First Virtuoso Chamber Music: *Five Movements for String Quartet, Op. 5*” in *The Atonal Music of Anton Webern*,<sup>7</sup> Allen Forte examines the structure of Op. 5, No. 1 in a manner primarily invested in the significance of juxtaposed octatonic structures throughout the movement as a syntactic and form-defining procedure.<sup>8</sup> The conclusions drawn from the following analysis were negotiated before consulting Forte’s analysis—a circumstance that eliminated any preconceptions regarding the presumed use of octatonic collections in the work. Instead, the following analysis inspects both melodic and harmonic pitch collections in light of Webern’s discernible

---

<sup>6</sup> Arnold Schoenberg, *Fundamentals of Musical Composition*, ed. Gerald Strang (New York: St. Martin’s Press, 1967), 200.

<sup>7</sup> Allen Forte, “The First Virtuoso Chamber Music: Five Movements for String Quartet,” in *The Atonal Music of Anton Webern* (New Haven: Yale University Press, 1998), 61–90.

<sup>8</sup> *Ibid.*, 68–90. The chapter as a whole continually emphasizes the octatonic basis for analysis, with the first mention of octatonic structures on p. 68.

preoccupation with symmetrical structures<sup>9</sup>—expressed in form, intervallic makeup, and transposition procedure as a means of promoting a hierarchy of structural elements and form-articulating contrasts. If the piece is analyzed without the presumption of octatonic structures, a network of symmetrical elements becomes evident.<sup>10</sup> Approaching the materials in this way validates the role played by the tetrachords (0145) and (0246) as materials upon which many harmonic connections are built—two important tetrachords not found in any single octatonic collection. The two analyses, Forte’s and the following, arrive at similar conclusions regarding form.<sup>11</sup> Forte’s will thus serve as an invaluable supplement to the following analysis despite dissimilarity in the interpretation of pitch collections with regard to function.

To posit pitch hierarchy in an atonal work such as Op. 5, No. 1 may seem a contradiction in terms, since the classification of primary and subsidiary pitches conflicts with the fundamental definition of “atonality.” A distinction, then, must be made between pitch hierarchy as a product of syntax within the musical materials themselves or, rather, as a product of an apparent emphasis on a particular set or pitch class to the point that it becomes a form-defining event. While a set class retains its identity through transposition, inversion, and permutation, the pitch-class composition of the set provides

---

<sup>9</sup> The subject of symmetry in Webern’s work has become commonplace in the literature of music theory. For studies focused on symmetry in the other movements of op. 5, see Bruce Archibald, “Some Thoughts on Symmetry in Early Webern: Op. 5, No. 2,” *Perspectives of New Music* 20, no. 2 (1972): 159–163; Paul Kabbash, “Aggregate-Derived Symmetry in Webern’s Early Works,” *Journal of Music Theory* 28, no. 2 (1984): 225–250; Joseph Straus, “Analysis 3: Webern, *Movements for String Quartet*, Op. 5, No. 4,” in *Introduction to Post-Tonal Theory*, 3rd ed. (Upper Saddle River, NJ: Prentice Hall, 2000), 119–129.

<sup>10</sup> The primary symmetrical tetrachords of the movement belong to set classes (0145) and (0246).

<sup>11</sup> Forte codifies the various themes of the movement (themes 1 and 2, as well as their respective recapitulated forms) into a sonata form model, which corroborate some of those identified in this analysis. His analysis differs slightly, as he considers “Fragment X” to be the first theme of the work. See Allen Forte, *The Atonal Music of Anton Webern* (New Haven: Yale University Press, 1998), 61–90.

a reference against which other collections may be weighed. Syntactic pitch hierarchy would imply that a specific collection of pitch classes has a naturally tendency to assert itself as a primary aural locus—namely, a tonic—based on the internal dynamics of a musical system; gravitation towards a pitch center contradicts the fundamental tenet of atonality. The use of a specific pitch-class set as a point of reference makes no assertion regarding the syntactic function of a the set, but rather questions the significance ascribed to a set that is given recurrent emphasis and formal character. In this analysis, particular motives are assigned a  $T_0$  status based on their original orientation in pitch-class space—a designation that will prove significant in light of the overall formal design and pitch-class polarity.<sup>12</sup>

In his writings on structuralism in “non-functional” music, Hermann Erpf asserts that the illusion of harmonic tension may be achieved through the use of a consistent tone complex as a periodic place-marker of sorts, against which surrounding harmonic material is judged.<sup>13</sup> George Perle’s own assertions support this claim: a particular pitch set may take on a functional meaning in light of its surrounding context. In the absence of

---

<sup>12</sup> Robert W. Wason cites additional instances in which a “ $T_0$ ” classification of early motivic elements yields pivotal form-defining implications in the works of Webern and Schoenberg. (Robert W. Wason, “A pitch-class motive in Webern’s *George Lieder*, Op. 3” in *Webern Studies*, Kathryn Bailey, ed. [Cambridge: Cambridge University Press, 1996].) In *Serial Composition and Atonality*, 2<sup>nd</sup> ed. (Berkeley: University of California Press, 1963), 13–15, George Perle highlights the significance of thematic elements first occurring at  $T_0$ , which later return to transposition level zero during the “recapitulation” of Schoenberg’s Op. 11, No. 1. Perle also asserts that certain chord structures in Webern’s work are, in light of surrounding harmonic structures, self-evident and thus can be “[employed] as a point of origin or destination of harmonic progression,” (ibid., 26–27). The large scale chromatic departure from, and return to,  $T_0$  as a form-articulating event in Webern’s music is found in Robert Hanson, “Webern’s Chromatic Organization,” *Music Analysis* 2, no. 2 (July 1983): 135–149.

<sup>13</sup> Herman Erpf, *Studien zur Harmonie- und Klangtechnik der neueren Musik* (Leipzig: Breitkopf & Härtel, 1927), 122.

tonal materials, the structural integrity of the piece relies primarily on the contrast between familiar sonic events and their counterparts.<sup>14</sup> Erpf states:

This tone formation, which is usually a dissonant many-toned one with a special charm of sound, achieves in a certain primitive sense the character of sound center from which the development originates and to which it always strives to return. The intermediary sections are contrasting, like the dominant emergence from the tonic, so that a certain tonic-nontonic-tonic change takes place, in which this structure still points back in the last analysis to functional harmony.<sup>15</sup>

This definition of structuralism, which alludes to neo-tonal practice, provides a basis upon which harmonic relationships may be judged over a large scale; harmonic transformations unveiled on a local level show formal significance in the movement as a whole. Bearing this in mind, the following formal scheme is proposed:

---

<sup>14</sup> Harmonic structures, timbral profiles, motivic content, etc.

<sup>15</sup> Herman Erpf, *Studien zur Harmonie- und Klangtechnik der neueren Musik* (Leipzig: Breitkopf & Härtel, 1927), 122, quoted in Robert Barclay Brown, "The Early Atonal Music of Anton Webern: Sound Material and Structure" (Ph.D. diss., Brandeis University, 1965), 32–33.

Figure 1. Formal layout of possible sonata form model.

Anton Webern - Op 5, No. 1  
Formal Design

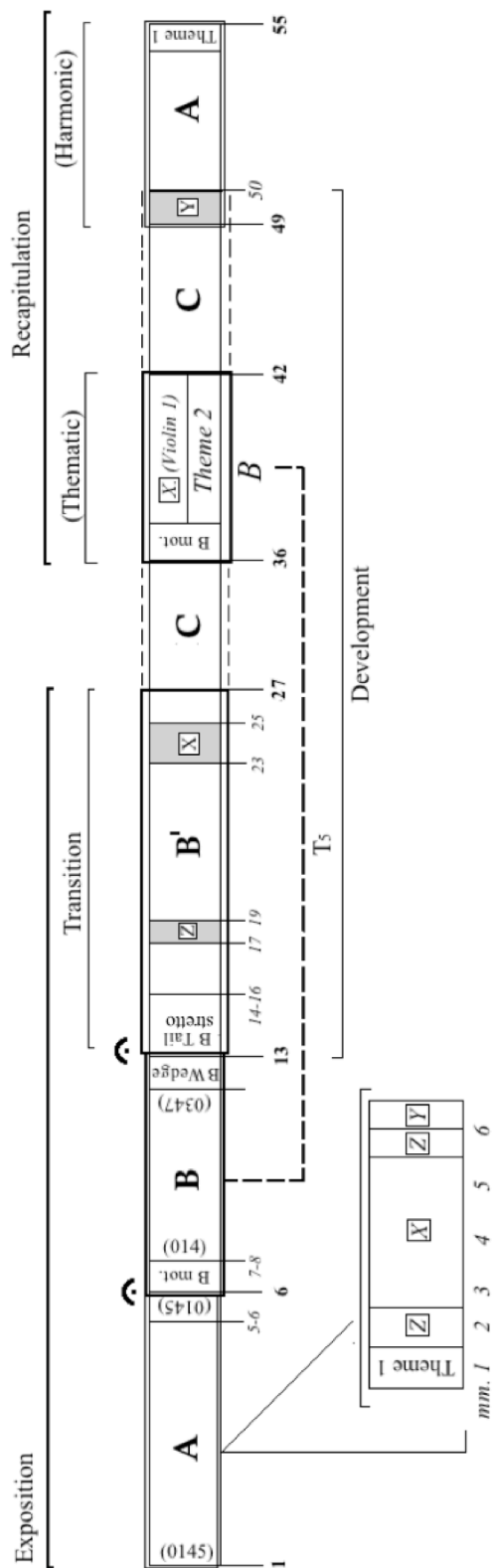

Like the exposition in sonata form, the opening section of Webern's string quartet provides a great deal of insight into the themes and harmonic syntax of the movement as a whole. To use a term codified by James Hepokoski and Warren Darcy, this opening section articulates a "structure of promise."<sup>16</sup> The A section comprises several isolated fragmentary components; presentation of these distinct fragments in the opening statement foreshadows their presentation as the work unfolds.<sup>17</sup> However, these components are all quite different in timbre and tone color. Each fragment has its own discrete timbral profile—*col legno*, harmonics, *pizzicato*—which remains consistent as the fragments reappear throughout the development section, making them instantly recognizable upon recurrence. These fragments are annotated in figure 2.

Figure 2. Discrete "fragments" that constitute the A section, mm. 1–6.

The image shows a musical score for Webern's string quartet, mm. 1-6. The score is annotated with boxes and labels for discrete fragments. Fragment X is marked at the beginning. Fragment Y is marked in the middle. Fragment Z is marked at the end. Fragment A is marked in the middle. The score is divided into two aggregates: 'Ist Aggregate' and '2nd Aggregate'. The score is also annotated with '(0145) Formal Periphery' at the beginning and end. The score includes various performance instructions such as 'pizz.', 'arco', and 'col legno'.

The first gesture of the movement, an augmented octave C–C#, shows promise as a form-articulating event. While the gesture moves rapidly, it is the sole musical

<sup>16</sup> James Hepokoski and Warren Darcy, *Elements of Sonata Theory: Norms, Types, and Deformations in the Late Eighteenth-Century Sonata* (Oxford: Oxford University Press, 2006), 18.

<sup>17</sup> Fragments X, Y, Z, and A (Theme 1).

statement in the entire piece that is reinforced in octaves.<sup>18</sup> Webern rearticulates the interval throughout the piece, even restating the pitch interval in every instrument (five times in violin 1 alone) at the conclusion of the movement. This augmented octave, always C–C#, constitutes Theme 1 in this analysis. Webern’s desire to work with minute, intimate materials is evident here: the composer effectively elevates a single pitch interval into the realm of formal significance—just as Eric Salzman puts it, the composer achieves a “maximization of the minimum.”<sup>19</sup>

Each fragment is stable—that is, each fragment represents a self-sufficient formal idea, demanding no resolution or explanation from the surrounding context. The reappearance of these fragments as the movement unfolds, therefore, tends to keep them from dissolving into their new surrounding musical context; preserved by their inherently independent nature, the fragments instantly recall their original foundation in the opening section of the work. For instance, the fermata chord in m. 6 is decidedly symmetrical in set class construction as the result of chromatic inflection of the first chord. The resultant chord is symmetrical along a pc 10/11 – 4/5 axis on the mod 12 clock, a division that gives rise to a pair of (0347) tetrachords.<sup>20</sup> In *Serial Composition and Atonality*, George Perle makes reference to this very set of chords, declaring: “because of its self-evident structure such a chord tends to have a somewhat stable character, which suggests its

---

<sup>18</sup> Atonal music has a tendency to avoid the use of harmonic octaves, which result in an inherent stress on a particular pitch class. See Arnold Schoenberg, *Theory of Harmony*, 3<sup>rd</sup> ed., trans. Roy Carter (Berkeley: University of California Press, 1978), 420.

<sup>19</sup> Eric Salzman, *Twentieth-Century Music: An Introduction* (Englewood Cliffs: Prentice-Hall, 1967), 41.

<sup>20</sup> Both tetrachords exhibit a vertical interval class construction of < 3, 5, 3 > and are partitioned accordingly: set [8, 11, 0, 1] in the viola and cello, and set [6,9,10,1] in violins 1 and 2.

employment as a point of origin or destination of a harmonic progression.”<sup>21</sup> This particular vertical structure plays the role of a harmonic refrain throughout the composition, with particular emphasis at the conclusion of the piece in m. 55.

The sets that encircle the A section exhibit a distinct property of mutual inversion,<sup>22</sup> which, despite their timbral isolation from the surrounding compositional texture in which they are found, enclose the section in a self-evident manner.<sup>23</sup> Recalling Perle’s earlier assertions, the deliberate use of such chord structures as the peripheral touchstones of the A section suggests a formal plan of harmonic circulation around an axis.

The entire A section comprises two full chromatic collections<sup>24</sup>—one in mm. 2–4 and another in mm. 4–6. This leaves the first one and a half measures and the final chord at the end of m. 6 to complete the A section. These remaining sets are both instances of set class (0145), and as seen in figure 3, they are related by inversion across a pc 0/1 – 6/7 axis (figure 3a). The pitch classes of Theme 1 constitute one pole of this axis on the mod 12 clock—thus, the constituents of Theme 1 possess both motivic and harmonic significance.

---

<sup>21</sup> George Perle, *Serial Composition and Atonality*, 2<sup>nd</sup> ed. (Berkeley: University of California Press, 1963), 27.

<sup>22</sup> See figure 3.

<sup>23</sup> While these two sets, both instances of (0145), are discrete musical ideas in their inception, their harmonic relationship articulates the beginning and end of a formal idea.

<sup>24</sup> The completion of chromatic aggregates as a form-defining event is a phenomenon that is often observed in Webern’s work, both in his twelve-tone works as well as in earlier pieces. See Allen Forte, “The Golden Thread: Anton Webern’s Early Songs,” in Kathryn Bailey, ed., *Webern Studies* (Cambridge: Cambridge University Press, 1996), 89. While completion of the chromatic aggregate is inevitable in any highly chromatic environment, the use of all twelve tones within a musical phrase suggests the completion of a compositional idea.

Figure 3. Inversion of (0145) tetrachord over 0/1 – 6/7 axis.

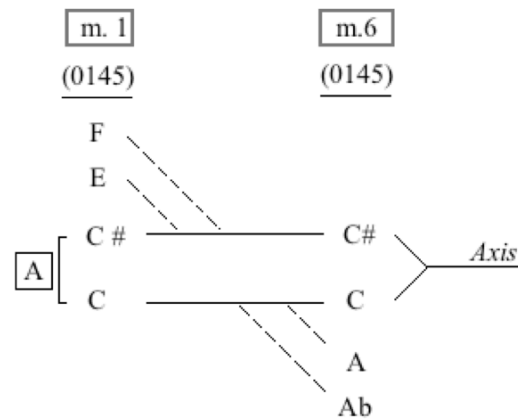

At the end of the “X fragment,” the ostinato figure in the first violin breaks free of its repeating pattern, initiating a passing stretto between all instruments (figure 4a). The ostinato, built from a (016) set class trichord, is transposed down in register by ic 4 as it is passed from violin 1, to violin 2, before it is transferred to the viola and ultimately to the cello. This gesture introduces an important construction used throughout the piece—the symmetrical stretto. In this particular instance, the set (016) is subjected to multiple  $T_4$  transpositions (figure 4b) where the third transposition maps the original set on to itself in a lower register. The trichord, which occurs at four distinct registral levels, can be said to have been transposed by  $T_4$  a total of three times. The highly symmetrical construction of the stretto lends itself to additional explanation—namely, that the overall chain of  $T_4$  transpositions yields two interlocking hexachords separated by  $T_8$  transpositions. This consideration will prove to be quite relevant when examining subsequent strettos and other highly symmetrical constructions throughout the piece.

Figure 4. Symmetrical transposition of stretto entrances.

A. m. 4

B. Transposition scheme of m. 4

$$[4, 9, 10] \xrightarrow{T_4} [8, 1, 2] \xrightarrow{T_4} [0, 5, 6] \xrightarrow{T_4} [4, 9, 10]$$

$\underbrace{\hspace{15em}}_{T_8} \qquad \underbrace{\hspace{15em}}_{T_8}$

As discussed earlier, the augmented octave (Theme 1) highlights a return to the A section at the end of the movement. Other fragments, however, are distributed less systematically—enough so that their role is not that of a formal place marker per se, but rather a brief recollection of the A section in passing. Thus, it is not until the end of the movement that this return to the A section is validated by the return of the augmented octave C–C#.

The B section, which houses several characteristic gestures and spans mm. 7–13 is set in motion by a contracting, wedge-shape figure found in the cello at m. 7. This contracting gesture may be expressed as  $\langle 4, 3, 2 \rangle$  in an ordered set of interval classes,

or as the contour  $\langle 0, 4, 2, 3 \rangle$ .<sup>25</sup> This figure will be referred to as the “B motive” throughout the analysis. This particular transposition and original exhibition of the set will be designated as  $T_0$ . The linear idea is harmonized by a pair of dyads in the viola, perhaps best described as a single dyad (ic 4) together with its semitonal transposition—thus outlining set class (0145). Just as the (0145) set class had functioned as a harmonic conclusion in the A section, the use of the same set class to accompany the B motive at the outer boundaries of the B section brings to light a common trend.

The B section contains two distinct components: the aforementioned B motive, and Theme 2, which is the primary lyrical melody of this section. Theme 2 occurs in mm. 9–13 as the principal voice of the musical texture. This lyrical passage is not subjected to the same developmental procedures as the B motive and is instead used as an aural cue, which signifies a return to the B section. The theme returns in mm. 38–43, played by the cello and viola. In this second iteration, the theme is still homophonic with subtle changes in interval quality; the rhythmic contour of the theme is well preserved, rendering it instantly recognizable.

---

<sup>25</sup> This analysis will use two means of describing contour: an ordered set of interval classes, which shows the exact size of contour, and a notational convention used to describe contour “levels” relative to the lowest sounding pitch (indicated as value 0). For more studies on contour theory and the aforementioned nomenclature, see Michael Friedmann, “A Methodology for the Discussion of Contour: Its Application to Schoenberg's Music,” *Journal of Music Theory* 29, no. 2 (Autumn 1985): 223–248. For a study of contour pertaining to Webern, see Steven Harper, “Contour and Melodic Structure in Two Homophonic Works by Anton Webern,” *College Music Symposium* 46 (2006): 105–122.

Figure 5. Set class composition of the second theme, mm. 9–13.

Theme 2

Inversionally Related

(0135) (0347) (0135)

(012) Trichord  
< -2, +1, -1 >

IC: 4 4 8 9 8 8 8 4 4 4 4 3

WT<sub>1</sub> (0246) (0246) (0268)

Pitch Palindrome  
(Viola)

Theme 2 is a sequence of dyads moving in similar motion, giving the impression of a single “line.” Partitioning the line into discrete tetrachords brings to light a semi-symmetrical arrangement of set classes. The line, harmonized in dyads, comprises three whole tone tetrachords: two (0246) and one (0268) set classes, two inversionally related (0135) set class tetrachords, and a (0347) symmetrical set class tetrachord. A complete chromatic aggregate is formed immediately before the line is harmonized in trichords and tetrachords, indicative of a complete melodic idea.<sup>26</sup> The material that follows, no longer harmonized exclusively in dyads—labeled (012) trichord in figure 5—contracts the melodic contour into a compressed pitch space. This final component of the B theme, a (012) chromatic trichord and its respective contour, will generate material in the upcoming C section.

<sup>26</sup> See note 12.



section, the narrative of departure and return to a specific idea, whether it be harmonic or motivic, is actively employed as a form-articulating device.

Figure 7. The two constituent parts of the B motive.

|         |                |                |
|---------|----------------|----------------|
|         | A. mm. 7-8     | B. mm. 8-9     |
|         |                |                |
| IC      | < 4, 3, 2 >    | < 1, 2, 6 >    |
| Contour | < 0, 3, 1, 2 > | < 3, 1, 2, 0 > |

Given the aforementioned close proximity of the wedge and the tail set, the wedge-shaped first half of the B motive that brought the B section to a close demands a statement of the tail. While the fermata at m.13 articulates a sectional division, Webern concludes the unpaired B motive by supplying the anticipated tail gesture immediately at the onset of the B' section under the guise of a descending *pizzicato* stretto. The tail set is extended into a canonic strand by operations  $T_2 - T_4 - T_2$ .<sup>28</sup> This transposition scheme results in two eight-pitch strands a tritone apart (see figure 8). Despite the clearly defined division of the two sections by the fermata at m.13, the motivic workings of the piece traverse this boundary in a way that anticipates the B' section as a complementary development section based on materials first introduced in the B section.

The significance of a  $T_6$  transposition here should not go unnoticed; bisecting the canonic strand yields two (0234568) heptachords,<sup>29</sup> symmetrical sets on the 0/1 – 6/7 axis. This particular set class is the precursor to a highly important collection in the latter

<sup>28</sup> In figure 8, “A” and “B” correspond to successive repetitions (entrances) of the canonic strand (mm. 14–15).

<sup>29</sup> Sets [2, 4, 5, 6, 7, 8, 10] and [8, 10, 11, 0, 1, 2, 4], respectively.

portion of the movement; expansion of the axis by ic 1 gives rise to the octachord (02345679). The polarity between the two axes of symmetry is still maintained, as the interplay between both 0/1 and 6/7 centricities becomes the framework for harmonic contrast.

Figure 8. Transposition of “tail” set in stretto, mm. 13–15.

Transposition of "Tail" set in Canonic Line

[ 2, 5, 6, 8 ] [ 4, 7, 8, 10 ] [ 8, 11, 0, 2 ] [ 10, 1, 2, 4 ]

Canonic Strand:  
 < 5, 6, 8, 2, 7, 8, 10, 4, 11, 0, 2, 8, 1, 2, 4, 10 >

While the *pizzicato* canon is saturated with transposed statements of the tail set, the rich texture of the canon embeds the set within a larger complex of pitches expressed in figure 8. Following the canon, two punctuated statements in violin 1 and 2 take the primary voice. These two statements (composed of three pitches each), when compiled into a single set in one register, constitute the familiar wedge-shaped component native to the B motive (figure 9).<sup>30</sup> After this statement, the first displaced fragment from the A section, the *col legno* “slap,” is revoiced at m. 17 (labeled “Z” in figures 1 & 2).

<sup>30</sup> Steven Harper asserts that Webern’s melodic lines are structured according to shapes that exist on several hierarchical levels. This will hold true for the wedge shape, which is often composed of smaller, wedge-

Figure 9. Combined wedge-shaped statements in violin 1.

1. m. 16      2. m. 17

IC    < 4, 3, 3, 3, 2 >

Contour < 0, 3, 1, 3, 1, 2 >

In a similar fashion to the B section, the B' section (which might otherwise be codified as a "closing section" in a traditional sonata form model) also emphasizes a lyrical melody in the musical foreground. The difference, however, lies in the construction of the melodic line; while the B theme is a stand-alone thematic idea, the melody of the B' section is merely an extension of the developing wedge shape. Close examination shows that the melodic line voiced by the viola extends the wedge shape further along its intended trajectory by filling in the final ic 2 so that the wedge-shaped contour centers on its most narrow point, as presented in figure 10.

Figure 10. Contracting wedge-shaped contour.

1. mm. 19-22

IC    < 4, 3, 2, 1 >

Contour < 0, 4, 1, 3, 2 >

---

shaped contours. See Steven Harper, "Contour and Melodic Structure in Two Homophonic Instrumental Works by Anton Webern," *College Music Symposium* 46 (2006): 105–122.

Clearly the B motive is a primary resource for musical coherence in the B' section; the connection between the two entities is so significant that the B' section must be considered an extension of the B section materials—a development, if you will. A final iteration of the wedge shape, paired with its usual “tail” complement, appears in violin 1 at mm. 36–38, after the first complete statement of the C section, or development, comes to a close (figure 11).

Figure 11. Wedge and tail sets of B motive return, violin 1, mm. 36–38.

|                |                |                |
|----------------|----------------|----------------|
|                | 1. mm. 36-37   | 2. mm. 37-38   |
|                |                |                |
| <b>IC</b>      | < 4, 3, 2 >    | < 1, 2, 6 >    |
| <b>Contour</b> | < 0, 3, 1, 2 > | < 1, 2, 3, 0 > |

Immediately following this statement, Theme 2 is reintroduced in the cello. During this return of the theme, the ostinato from the A section labeled “Fragment X” repeats in violin 1 (mm. 36–42). While the intervals of the theme have been subject to change, both the rhythm of the passage and respective contours provide reliable cohesion between the original theme and its subsequent reproduction, which has been transposed by  $T_5$  (figure 12b). The close proximity of the transposed, harmonized B motive (figure 12a) and Theme 2 thus suggests a recapitulation of B section materials.<sup>31</sup>

---

<sup>31</sup> The return to the B section suggested here is primarily thematic, as the respective pitch materials from which the theme is reconstructed are transposed up by  $T_5$ , which now state the B section materials “in a new key.”

Figure 12. Return of B section materials, mm. 36–42.

**B Motive ( $T_5$ )**

A. *Wedge Tail*

Viola + Cello

(0246) Tetrachord ( $T_5$ )

B. **Theme 2 ( $T_5$ )** *Repeated Material*

(0246) (0135) (0246) (0246) (0347)

$WT_0$

In his article, “‘Tonal’ Forms in the Arnold Schoenberg’s Twelve-Tone Music,” Andrew Mead comments on a similar phenomenon observed in one of Schoenberg’s works:

The first movement of Schoenberg’s *Wind Quintet*, Op. 26, is perhaps the most notorious example of a twelve-tone movement imitating a tonal form. It appears to be a text-book sonata-allegro, with a repeated exposition complete with “first theme,” “second theme,” and a transitional passage connecting them; it contains a development section, and, most damning of all, a recapitulation in which the “second theme” is transposed up a perfect fourth, the appropriate interval had this indeed been a tonal work with the second key area the dominant.<sup>32</sup>

The transposition of B section materials by  $T_5$  is quite striking in light of the frequent  $T_6$  transpositions that had set the standard for harmonic polarity throughout the piece (particularly in the upcoming A’ section).  $T_6$  relies on opposing sides of the mod 12 clock in order to establish contrast, while transposition of thematic material by  $T_5$  bears

<sup>32</sup> Andrew Mead, “‘Tonal’ Forms in the Arnold Schoenberg’s Twelve-Tone Music,” *Music Theory Spectrum* 9 (Spring 1987): 73.

historical significance as a tonal dichotomy. On the level of perception, transposing the theme accordingly recalls tonal practice in absentia—the second theme has now been transposed up a fourth to the “tonic” key. Mead goes on to say that the sonata form principle exerts subtle influence on the form of Schoenberg’s tripartite works, but a literal sonata form model requires several features not fundamental to atonal works. Instead, pitch class polarity and set relationships like those between tonic and dominant in tonal practice signal and direct changes in form.<sup>33</sup> It should be noted, however, that Theme 2 is predominantly composed of tetrachords belonging to the whole tone collection on C#. Transposition by  $T_n$ , where  $n$  is an odd value, will map these tetrachords onto the other whole tone collection on C. Transposition of the theme by either  $T_5$  or  $T_7$  maps the collection onto the other hemisphere of the mod 12 clock, and subsequently changes whole-tone collections. The materials that constitute the B section (the B motive and Theme 2) are now transposed to a new, and presumably “tonic,” key at the start of the recapitulation. Recalling the rhetorical goal of sonata form, thematic materials once heard in a foreign key during the exposition are now presented in the tonic key.

It would appear as though the various motivic connections drawn between each representation of the B motive provide ongoing structural support for the piece. In light of this network of developing components, intermittent contrasting sections introduce seemingly new material—material that is first observed following the completion of a full chromatic aggregate within Theme 2: the (012) trichord as a descending gesture. The two contrasting subsections, labeled “C”, are in some way extensions of the B section, this

---

<sup>33</sup> Ibid., 89–90.

time bringing a less significant gesture within the B section to prominence as the principal voice.<sup>34</sup>

The explicit development of themes from the A and B sections occurs during these C sections, which generates seemingly new material from reduced, retrograded or inverted contours and sets from the prior section. The wedge shape contour native to the B motive, for instance, is retrograded and truncated,<sup>35</sup> while the (012) descending chromatic trichord at the end of the second theme becomes a prominent focal point.

The (012) trichord occurs at the peripheries of the C section, articulating both the inception and termination of the C section. An identical gesture begins each iteration of the C section: a stepwise descending chromatic line,  $\langle -1, -1 \rangle$  in ordered pitch intervals, as seen in figure 13, c. 1. Following this short chromatic descent is a truncated expanding wedge—composed of three pitches, the contour is expressed as  $\langle +3, -4 \rangle$  (figure 13, c. 2). The final characteristic gesture of the C section is a (013) set, expressed  $\langle +2, -2, -1 \rangle$  (figure 13, c. 3).

---

<sup>34</sup> Generally, violin 1 supports the principal voice. This notion is strengthened by subsequent reiterations of key motivic / thematic events punctuated in the upper register.

<sup>35</sup> First example found in violin 1, m. 28.

Figure 13. Defining characteristics of the C, or development, section.

A. (mm. 26 - 29)

Vn. 1

C. 1 C. 2 C. 1 (Permutation) C. 2 (Inflected)

B. (mm. 44 - 46)

Vn. 1

Vc.

C. 3 C. 1 C. 1 (Permutation) C. 2

Before returning to the figurative (and literal) recapitulation of themes and harmonic materials of the A section, Webern transitions to the A' section with an ascending stretto at m. 47 (figure 14a),<sup>36</sup> which rapidly climbs registral space in order to punctuate a final statement of the (012) trichordal gesture, subsequently heightening registral contrast before transition into the recapitulation section. In a similar fashion to the stretto that occurs in mm. 14–15, the one in m. 47 employs a repeated sequence of pitches: < F#, F, Bb, A, D, C# >. Webern's spacing of the tetrachordal gestures that make up the stretto projects several notable harmonic configurations. Tetrachordal segments may be inferred by their respective barring within the stretto (figure 14b, dotted outline) generating multiple (0145) sets. The pitches may also be read horizontally, bisected by

<sup>36</sup> The intervallic and gestural makeup of this stretto recalls the earlier use of this same device in mm. 14–15 (figures 4 and 8) but this time in an ascending, retrograded fashion.

registral detachment resulting in multiple (048) trichords (figure 14b, barred). Both readings yield symmetrical sets, including the rudimentary augmented triad as a kind of lateral stepping-stone. While the stretto does promote both set groupings in a cogent way, reducing the pitches to a single set reveals a highly significant hexachord: set class (014589). This is the same hexachord responsible for the harmonic underpinnings of the A section, yet it has been transposed to its complement at the apex of the development section, indicating a large scale motion away from the original (014589) harmonic collection that surrounds in the A section.

Figure 14. Set class composition of second stretto during retransition to A' section.

A. mm. 46–47; articulations removed.

The image shows a musical score for four staves, divided into two measures by a vertical bar line. The top two staves are in treble clef, and the bottom two are in bass clef. The music consists of various rhythmic patterns and chords, with some notes beamed together. The key signature has one flat (B-flat). The notation includes eighth and sixteenth notes, rests, and chord symbols.

B. mm. 46–47; stretto realigned.

The image shows a musical score for three string parts: Violin I, Violin II + Viola, and Violoncello. The music is in 3/4 time and consists of two measures, 46 and 47. The Violin I part is in treble clef, Violin II + Viola is in alto clef, and Violoncello is in bass clef. The key signature has one sharp (F#). The music features an ascending stretto. Beams and dotted outlines are used to highlight specific set classes. A legend at the bottom identifies the symbols: a solid beam represents Set Class (048) and a dotted outline represents Set Class (0145).

Violin I (048)

Violin II + Viola (048)

Violoncello (048)

• **Beams:** Set Class (048)  
• **Dotted Outline:** Set Class (0145)

This ascending stretto is only part of a larger transitional procedure aimed toward the recapitulation of the A section. The aforementioned (012) melodic cell, which had previously been a staple of the C section, is now subjected to a series of subtle transformations and permutations. The final two phrases of the C section are “call and response,” respectively: the (012) trichord is stated in a descending fashion before being answered by an enlarged cell, (014), also in a descending manner.<sup>37</sup> Webern effectively opens up the otherwise restricted pitch space of the C section before crossing into the A' section. This maneuver prepares the first melodic statement of the A' section—a (014)

<sup>37</sup> This pair of sequenced descending chromatic gestures clearly paraphrases Schoenberg's milestone string sextet *Verklärte Nacht* (1899). See mm. 79–82 marked “Etwas zurückhaltend” in Arnold Schoenberg, *Verklärte Nacht* (Berlin: Verlag Dreililien, 1905; reprint Mineola: Dover Publications, 1994), 10.

expanding wedge. While the original call and response pair shared a similar contour, an inflection of the response statement generates pitch material for the upcoming expanding wedge statement at the beginning of the A' section.

Figure 15. Melodic retransition into the recapitulation section.

*Development* *Recapitulation*

---

C Section A' Section

Pivot Chords / Transition

A.                      B.                      C.

Contour    < 2 1 0 >                      < 2 1 0 \* >                      < 1 2 0 >

Set Class    (012)                                      (014)                                      (014)

The final A' section, which focuses on materials initially presented in the A section, begins at m. 49, first articulated by the return of the Y fragment (a pair of dyads which expand in contrary motion by step, embellished by a crescendo) after which a resounding C–C# augmented octave (Theme 1), becomes the melodic focal point until the piece comes to a close. The interval is continually stated in violin 1, deliberately

becoming the subject of the musical surface. It is restated at least once in each instrument, signaling the return of the same augmented octave that had set the piece in motion.

The chordal harmony that articulates the start of the A' section belongs to set class (02345679) and, remarkably, this set class accounts for the final chord of the piece.<sup>38</sup> Recalling earlier assertions supported by Perle and Erpf regarding referential transposition levels as structural articulations, the first and final chord of the A' section sit on opposite hemispheres of the mod 12 clock (figure 16, a and b), which results in a direct harmonic contrast of considerable formal significance. The (02345679) set class is first introduced in the collection [2, 4, 5, 6, 7, 8, 9, 11] at m. 49. The set is transposed to [8, 10, 11, 0, 1, 2, 3, 5] at m. 55, bringing both the A' and the movement as a whole to a close. Symmetrical distribution of harmonic materials around the 0/1 – 6/7 axis has already been discussed; it should be no surprise that the symmetrical configuration around the same axis in the final chord is noteworthy. In one of his lectures on composition in the “new style,” Webern supports this literal harmonic polarity as an analogue to the harmonic polarity in tonal practice. He remarks:

Considerations of symmetry, regularity are now to the fore, as against the emphasis formerly laid on the principal intervals—dominant, subdominant, mediant, etc. For this reason the middle of the octave—the diminished fifth—is now most important. For the rest, one works as before. The original form and pitch of the row occupy a position akin to that of the “main key” in earlier music; the recapitulation will naturally return to it. We end “in the same key!” This

---

<sup>38</sup> The fermata chord that ends the A section is the second chord in a pair of chords that constitute the Y fragment; this, due to its symmetrical construction, is the presumed harmonic goal brought on by chromatic inflection of the first chord. This procedure generates symmetrical set class (02345679) through the union of two (0347) tetrachords.

analogy with earlier formal construction is quite consciously fostered; here we find the path that will lead us again to extended forms.<sup>39</sup>

Figure 16. Transposition of (02345679) octachord across hemispheres of the mod 12 clock.

A. Pitch distribution around both poles of the 0/1 – 6/7 axis, mm. 49–55.

m. 49 m. 55

F# / G C / C#

2 1 1 1 1 1 2 2 1 1 1 1 1 2

[ 2, 4, 5, 6, 7, 8, 9, t ]  $\xrightarrow{T_6}$  [ 8, t, e, 0, 1, 2, 3, 5 ]

B. Pitch distribution around the mod 12 clock.

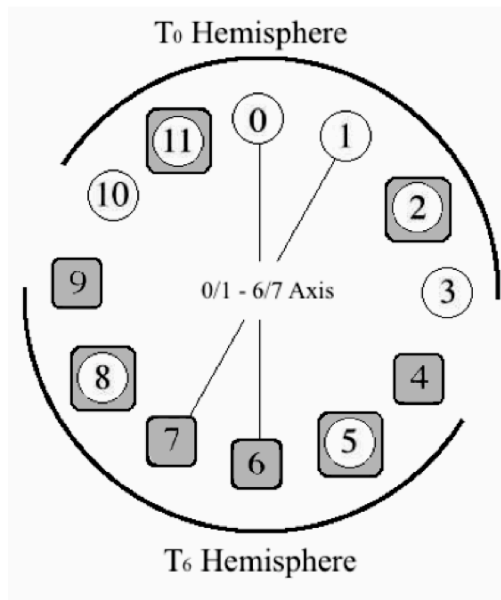

Circled pitches belong to (02345679) at  $T_0$ ; boxed pitches belong the set at  $T_6$  transposition.

<sup>39</sup> Anton Webern, *The Path to New Music*, 54, quoted in Kathryn Bailey, *The Twelve-Note Music of Anton Webern: Old Forms in a New Language* (Cambridge: Cambridge University Press, 1991), 150.

As a result of the recurrent focus on the pitch space surrounding the 0/1 – 6/7 axis, it is evident that the final chord has been transposed to the referential  $T_0$  level. The  $T_6$  transposition level that starts the section thus constitutes the literal polar counterpart to  $T_0$ . While Webern had transposed Theme 2 by  $T_5$  earlier in the movement, this final  $T_6$  transposition of harmonic axis represents an abandonment of pseudo “tonal” notions of pitch polarity in favor of a more literal (and consequently, more exaggerated) counterpart to  $T_0$ . The preceding development section thus displaces the axis of symmetry far from its original transposition level before highlighting a return to  $T_0$ .<sup>40</sup>

Close examination of the 0/1 – 6/7 axis construction of the opening A section and the subsequent A' section reveals a striking metamorphosis in symmetrical design, as presented in figure 17. The harmonic arrangement around the axis, the juxtaposition of two (0145) tetrachords,<sup>41</sup> generates the symmetrical hexachord (014589).<sup>42</sup> The final chord, which belongs to set class (02345679), is divisible into two (0347) tetrachords—a division brought to light by Webern’s own orchestration, with pcs [10, 1, 2, 5] in the cello and viola, and [8, 11, 0, 3] in violins 1 and 2. While this consistent expansion of pitch structures around the 0/1 – 6/7 axis affirms its importance as a referential center, closer examination of the finer details reveals an even more refined transformation.

---

<sup>40</sup> The transposition of principal sets by  $T_6$  has been observed previously—the stretto in mm. 14–15 is built upon a canonic chain produced by the two-fold transposition of a (0234568) heptachord.

<sup>41</sup> Tetrachords [0, 1, 4, 5] and [8, 9, 0, 1].

<sup>42</sup> This set foreshadows Webern’s “derived row” from his *Concerto for Nine Instruments*, Op. 24. The row is generated from a symmetrical ordering of four (014) tetrachords into a single row. Bisecting the row yields two of such (014589) hexachords, which have extensive combinatorial potential. A comprehensive study of this row and its symmetrical construction is found in Kathryn Bailey, “Symmetry as Nemesis: Webern and the First Movement of the Concerto, Opus 24,” *Journal of Music Theory* 40, no. 2 (Autumn 1996): 245–310.

Figure 17. Pitch class distribution around one end of 0/1 – 6/7 axis, in  $T_0$  hemisphere of the mod 12 clock, m. 55.

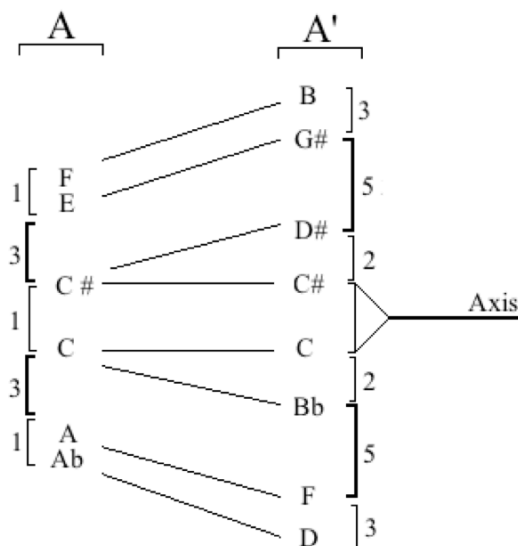

Both (0145) and (0347) class tetrachords are composed of (014) subsets, and each tetrachord may generate the other by simply repositioning one of its constituent trichords. Set (0145) is produced by two inversionally related (014) trichords juxtaposed, overlapped at ic 3. Set (0347), on the other hand, shares the same structure but instead the overlapped interval is ic 1 (see figure 18).

Figure 18. (014) trichords arranged in both (0145) and (0347) tetrachords.

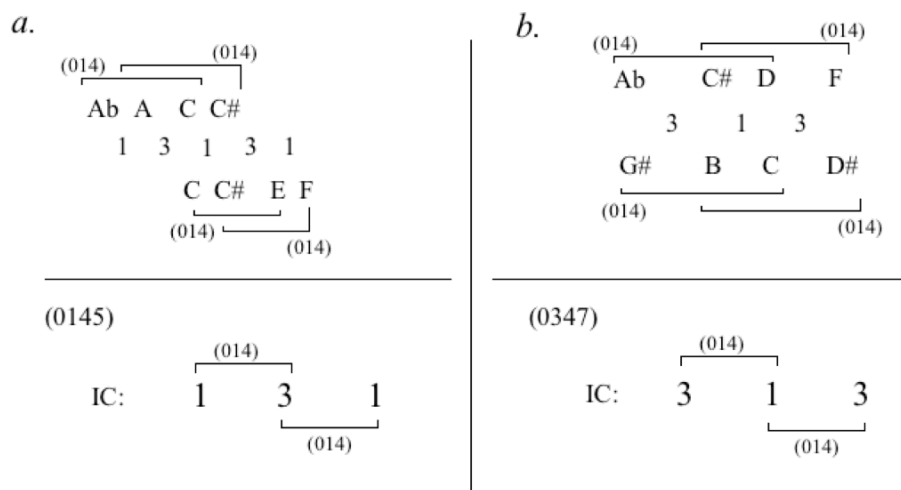

Harmonically, this extension of the original (014589) set class is still built upon the same intervals—half steps and minor thirds—yet the vertical, symmetrical structure has been permuted in such a way that it suggests not only an arrival, but also a culmination. Centered on the 0/1 pole of the axis, the final chord concludes the piece by returning focus to the  $T_0$  referential transposition level of the mod 12 clock.

While the majority of the compositional texture is polyphonic, Webern articulates various decidedly chordal structures throughout the movement.<sup>43</sup> A reduction of these chords is shown in figure 19. This reduction brings to light several qualities of the movement pertinent to its form. The B sections, for instance, are primarily composed of melody and accompaniment; Webern does not interrupt this texture with clearly articulated chords like those prevalent in other sections. The most significant observation to arise from this reduction reveals that the chord that ends the B' section at m. 17 shares an intimate connection with the axis chords discussed in the A' section and the form as a whole—in fact, it is the same chord that ends the piece. Reducing the quasi-sonata-form model to its constituents (exposition, development, recapitulation) reveals a tripartite form solidified by the aforementioned harmonic correspondence.

---

<sup>43</sup> In some instances the harmonic structures are not explicitly “chordal.” In such cases the vertical structure is implied, articulated by simultaneous attacks in each instrument.

Figure 19. Reduction of chords, mm. 1–55.

The figure displays two systems of musical notation representing chord reductions. The first system, labeled 'A', 'B', 'B'', 'C', and 'B', spans measures 1 to 55. It includes a '15ma' marking above measure 6. The second system, labeled 'C' and 'A'', spans measures 42 to 55. Both systems show chord reductions in treble and bass clefs.

While the harmonic progression aims to realign the (02345679) octachord with its axis on the mod 12 clock, the pitches of that pole, C and C#, are emphasized as foreground material in violin 1, signaling the return of Theme 1. This return to the opening interval projects a great deal of insight into the overall formal narrative, indicating an even larger and more comprehensive ABA' structure beneath the surface. Figure 1 (as reinforced by figure 19) makes an allusion to this possibility, with the formal plan partitioned into A Section – B Section – Development (comprising both fragments from the A section, as well as the themes and motives of the B section with C section interjections) – A' section. While the A and B sections are clearly partitioned into their own distinct segments, an argument, not for two sections, but rather, two theme groups, becomes remarkably credible in light of the overall formal tendencies of the piece.

Treatment of motives and fragments aside, the abundance of material derived from the first two sections that make up the development communicates an underlying sonata form philosophy. Motivic variation, perhaps more than anything, leads the analyst towards a more comprehensive form than a crude ABA' model. Of course, one cannot discount the various textural contrasts that define the way in which the composition is initially perceived. While the brevity of Webern's output is the product of meticulous attention to detail, the delineation of form requires analysis of several factors; examination of one factor, such as pitch-class set and collection, proves insufficient. One must note the variable parameters like pitch, rhythm and contour that provide musical cohesion beyond deliberate sectional articulations implied by local textural contrasts, tone colors and phrase breaks.

As this analysis shows, the question of form in Anton Webern's *Five Movements for String Quartet*, Op. 5, No. 1 requires careful observation at all levels of form and structure. While it is tempting to ascribe pivotal significance to sectional divisions implied by fermatas and sudden textural shifts, the underlying formal archetype of Webern's composition lies beneath that level of perception. The question of form as it applies to this work is split into two concerns: form as it is perceived, on one hand; fundamental syntax on the other. It is possible to hear this movement in a hastened rondo form that constantly recalls its opening section—an interpretation primarily informed by Webern's deliberate evasion of clear tripartite structure. Conversely, the archetypal ABA' form that runs deep beneath the surface provides significant coherence despite its lack of clear representation on the level of perception. The two interpretations are self-complementing and concurrent, operating at the same time while providing both

structural and syntactic ramifications for the piece. The two principal themes of the work sit on two ends of a spectrum: one elevates a two-pitch gesture to thematic significance, while the other is an undisguised, lyrical melody. The transposition of the latter into a new key during the final section conforms to the fundamental principle of sonata theory; restating material first heard outside the tonic key, now in the tonic key, is the ostensible goal. As a motivic matter, the formal plan and developmental procedure clearly pay homage, from a distance, to the venerated sonata-allegro form—a deliberate and calculated effort to link the tonality of the modern with the sensibilities of the past.

## Chapter II:

*Musique Vivante*: The Divine Influence on Symmetry, Duration and Cardinality in Olivier  
Messiaen's *Visions de l'Amen*

While explicitly “liturgical” music makes up only a small fraction of Olivier Messiaen’s extensive oeuvre, a certain religious character marks a great deal of his early music; nearly every facet of his output is informed and influenced by his faith. Rejecting the title of a “mystic” composer,<sup>1</sup> Messiaen seeks to compose living music—music that comes to life through the merits of its design.<sup>2</sup> He proclaims:

Living music. Living through its subject, living through its language. The word “life” recurs constantly in the Gospels; our Catholic sacraments and liturgy are, above all, and organism of spiritual life, and all Christians aspire towards eternal life. The language of the musician-believer will thus try to express the life.<sup>3</sup>

The presence of God in Messiaen’s spiritual life directly influences the “life” he wishes to express in his work; it results in a *musica sacra* regardless of subject matter or musical narrative. In his article, “Religious Music: Its Time and Reality,” Klaas Glosers asserts that this brand of religious music “tries to render the atmosphere in which it wants to be understood; it shows deliberate humility, piety, to express that as religiosity.”<sup>4</sup> While many analyses touch upon the use of numerology and symbolism in Messiaen’s music, the

---

<sup>1</sup> While Messiaen rejected the title of a “mystic” in the traditional sense, his composition *Visions de l’Amen* is based on several definitions of “amen” established by reputed mystic, and author, Ernest Hello. Paul Griffiths, *Olivier Messiaen and the Music of Time* (Ithaca: Cornell University Press, 1985), 109.

<sup>2</sup> Stephen Schloesser, *Visions of Amen: The Early Life and Music of Olivier Messiaen* (Grand Rapids: William B. Eerdmans Publishing, 2014), 301.

<sup>3</sup> Olivier Messiaen, “Musique Religieuse,” in *Olivier Messiaen: Journalism, 1935–1939*, ed. Stephen Broad (Surrey, UK, and Burlington, Vt.: Ashgate, 2012), 125.

<sup>4</sup> Klaas Glosers, “Religious Music: Its Time and Reality,” *Contemporary Music Review* 12, no. 2 (August 2009): 118. Similarly, Robert Sholl describes Messiaen’s religious focus as a “shock of positive,” which merely uses the extended aesthetic vocabulary of modern music as an affirmation of divinity. This technique of “shock” is discussed in Timothy Cochran, “Rhythmic Contrast in Debussy and Messiaen,” *The Journal of Musicology* 31, no. 4 (Fall 2014): 522–524.

topic is often addressed superficially. The depth of Messiaen's symbolic vision reaches far below the surface level—its influence shapes the formal narrative in a thoroughgoing way.<sup>5</sup> This analysis, comprising two parts, will explore the use of symmetry, large-scale rhythmic structures, and recurring numerical values as the principal devices that “bring to life” Messiaen's piece for two pianos, *Visions de l'Amen*. The first part of this study examines the outer movements of the seven-movement work, which highlight and draw attention to the same theme as their principal melody. In terms of form, this significant emphasis on a common theme articulates the beginning and end of the formal narrative, as well as a cyclic return. The second part of this analysis examines the “nested” movements, which are enclosed by the two closely related outer movements, and also function in similar ways.

Messiaen customarily provides a great deal of insight into his compositional process by way of annotations to his scores that identify rhythmic modules, interventions, non-retrogradable rhythms and even the specific species of birds emulated in his orchestration. Messiaen prefaces the score to *Visions de l'Amen* by listing brief descriptions of generalized processes, themes and qualities expressed within each movement.<sup>6</sup> These annotations, in addition to the composer's own analysis presented in the third volume of his *Traité de Rythme, de Couleur, et d'Ornithologie*, will supply supplementary information to the following study.

---

<sup>5</sup> Paul McNulty notes that the use of “blatant” Christian symbols was a prominent feature of Messiaen's music until 1949–1951, after which Messiaen began to explore more abstract means of musical communication. Paul McNulty, “Messiaen's Journey Towards Asceticism,” in *Messiaen Studies*, ed. Robert Sholl (Cambridge: Cambridge University Press, 2007), 63–77.

<sup>6</sup> Oliver Messiaen, “Note de l'Auteur,” *Visions de l'Amen* (Paris: Durand, 1943), n.pag.

Before focusing on the individual movements of the work, it is important to address the significance of the numerical values three, five and seven.<sup>7</sup> It is known that Messiaen often embedded various religious symbols in his work, including various “Trinitarian” number sequences.<sup>8</sup> Seven is widely considered one of the integral values in Christian numerology: notable instances include the opening phrase of the Bible (in its original language), which comprises seven words; the Holy Spirit’s bestowal of seven gifts to the world;<sup>9</sup> Jesus’s seven last words before dying on the cross; and countless other instances of seven throughout the Bible.<sup>10</sup> Messiaen’s only other seven-movement work prior to *Visions de l’Amen, Les Corps Glorieux* (1939), also centered on a sacred narrative. Within each movement, the other numerological values three and five also receive considerable emphasis: three is synonymous with the Holy Trinity, and five is related to man (who possesses both duality and the Holy Spirit: 2 + 3). It should be noted that all three numerical values are odd numbers; when used throughout the piece as structural elements, the middle value often functions as either an axis of symmetry or a fulcrum between two otherwise balanced halves. These numbers are ideal in their use as templates for symmetrical

---

<sup>7</sup> It should be noted that three, five and seven are all prime numbers. In a conversation with Claude Samuel, Messiaen suggests that prime numbers, which are only divisible by one or the number itself, reflect the indivisible nature of divinity and God. Olivier Messiaen and Claude Samuel, *Music and Color: Conversations with Claude Samuel*, trans. Thomas E. Glasow (Portland: Amadeus Press, 1994), 79.

<sup>8</sup> Andrew Shenton examines the use of literal codes and ciphers in Messiaen’s work. See Andrew Shenton, “The Semiotic System in Context,” in *Olivier Messiaen’s System of Signs* (Surrey, UK, and Burlington, Vt.: Ashgate Publishing, 2008), 137–158.

<sup>9</sup> Messiaen makes explicit reference to the “seven gifts” in four of his works: “Minuit pile et face” in *Chants de terre et de ciel* (1938), the “Consécration: le don de Sagesse” in *Messe de la Pentecôte* (1949–1950), “Cedar Breaks et le don de Crainte” in *Des Canyons aux étoiles*, and the seventh movement of his *Méditations sur la mystère de la Sainte Trinité*. Siglind Bruhn, *Messiaen’s Interpretations of Holiness and Trinity: Echoes of Medieval Theology in the Oratorio, Organ Meditations, and Opera* (Hillsdale: Pendragon Press, 2008), 44.

<sup>10</sup> It is argued that seven also signifies the “fullness” of time, an assertion based on the seven-day week created in Genesis. Maria Anne Harley, “To be God with God: Catholic composers and the mystical experience,” *Contemporary Music Review* 12, no. 2 (August 1995): 142.

structures. Prominent symmetrical structures and the aforementioned numerical values are often observed concurrently in the same musical formation, which suggests they are fundamentally linked—two sides of the same coin, so to speak. The present analysis investigates what *isn't* written in the preface; it inspects the intimate connections between Messiaen's compositional technique, the narrative, and the nature of his devout spirituality. A thorough analysis of Messiaen's *Visions de l'Amen* reveals more than just pragmatic compositional design.

### **The Act of Creating**

This first part of this study focuses on the first and final movements of the piano cycle: movement I, "Amen de la Création," and movement VII, "Amen de la Consommation." Delineating the outer boundaries of the composition, the first and final movements share similar thematic material—namely, the "creation theme" as identified in Messiaen's own program notes.<sup>11</sup> Textural similarities affirm the close relation of these two movements, as the composer assigns similar functional responsibilities to each piano. The background processes of piano 1 illustrate the environmental conditions of the narrative, while the "creation theme," projected by piano 2, is elevated to the surface.

---

<sup>11</sup> Oliver Messiaen, "Note de l'Auteur," *Visions de l'Amen* (Paris: Durand, 1943), n.pag.

## I. Rhythm and Compound Periodicity

Driven by his adoration of the divine, Messiaen has developed a collection of rhythmic procedures designed to express the infinite expanse of time. While many rhythmic techniques described in his *Technique de mon langage musical* pertain to the structure and effect of rhythmic pulse at a local level, Messiaen's application of *talea* and *color* as a self-regulating process results in a seemingly endless stream of pitch material and rhythmic activity that unfolds over the course of an entire section. The *talea* is a pre-composed, repeating rhythmic module.<sup>12</sup> It progresses simultaneously with the *color*, an ostinato of, in this instance, chords. The process is prolonged or shortened by adjusting the length of either the *talea* or *color* so that the simultaneous unfolding of both collections either will, or will not, yield an immediate resynchronization.<sup>13</sup> The relationship between durations of the *talea* and the chords of the *color* may be simple; in some instances synchronization may occur after as few as two or three statements. More complex relationships between the number of durations and the number of chords, especially the interrelation between two prime number values, yield extensive periods of concurrent unfolding before the occurrence of a resynchronization. In *Visions*, the juxtaposition of *talea* and *color* constitute a musical device called the "carillon of light," an object of the narrative that generates the sensation of

---

<sup>12</sup> Messiaen describes this technique as "rhythmic pedal" in *The Technique of My Musical Language*, trans. John Satterfield (Paris: Alphonse Leduc, 2002), 26.

<sup>13</sup> Length, as it pertains to *talea*, is the total length of the entire rhythmic module. Length of the *color* corresponds to the total number of chords successively arranged in the *color*.

timelessness; its occurrence in the first, fourth and seventh movements results in thematic significance.<sup>14</sup>

Both pianos play very different, yet equally important roles throughout the course of the composition. Written to be performed by his student at the time, Yvonne Loriod, and Messiaen himself,<sup>15</sup> to each part is ascribed a unique character and function that remain fairly consistent throughout all seven movements. Piano 1 develops the timeless, infinite backdrop for the inception of the creation narrative; it functions as a medium for self-generating processes like *talea* and *color*. Messiaen identifies several key non-retrogradable modules used to produce the overarching *talea*. These modules are annotated in the score, and detailed by Messiaen in the *Traité*;<sup>16</sup> these modules are labeled A, B, C, D, and E in this analysis (figure 1.1). Messiaen's frequent use of non-retrogradable rhythms stems from their ability to "draw (their) power from a temporal impossibility."<sup>17</sup> For Messiaen, the resultant "stasis" of non-retrogradable rhythm forms a paradox—a single rhythmic pattern that inherently recalls its past (in reaction) even as the rhythm moves forward, preventing any sense of direction.<sup>18</sup> Indeed each rhythmic module has this effect, but it is curious that Messiaen juxtaposes several non-retrogradable rhythms into larger, fully retrogradable

---

<sup>14</sup> Messiaen often specifies that this device should be played "carillonment."

<sup>15</sup> Peter Hill, "Piano Music 1," in *The Messiaen Companion*, ed. Peter Hill (London: Faber and Faber, 1995), 81.

<sup>16</sup> Olivier Messiaen, *Traité de Rythme, de Couleur, et d'Ornithologie*, II (Paris: Alphonse Leduc, 1995), 56.

<sup>17</sup> "...tirent leur force d'une impossibilité temporelle," *ibid.*, 7.

<sup>18</sup> Jennifer Donelson's explanation behind the symbolism of such stasis is quite compelling. She asserts, "because the rhythm contains a *central* value, it is as if s/he (the listener) can perceive all the values simultaneously in an analogous way to how God, who is eternal, simultaneously perceives all points in time as a single moment." Jennifer Donelson, "Musical Technique and Symbolism in *Noël* from Oliver Messiaen's *Vingt Regards sur l'Enfant-Jésus*: A Defense of Messiaen's Words and Music" (D.M.A. diss., University of Nebraska, 2008), 38. Emphasis in original.

(asymmetric) repeating units. On the microcosm, each rhythmic pattern suspends motion and creates the sensation of timelessness; in long-range terms their conscious use as temporal building blocks conflates time and space.<sup>19</sup>

Figure 1.1. Non-retrogradable rhythmic modules in “Amen de la Création.”

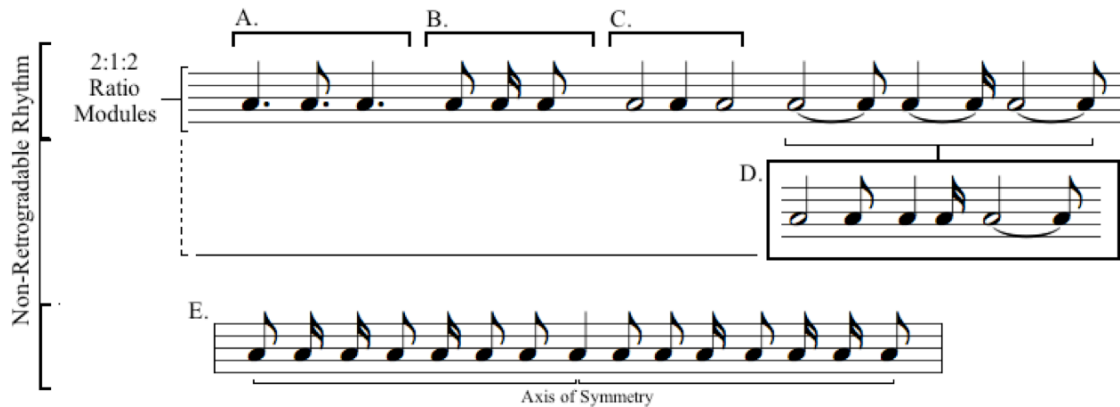

Upon initial observation, select rhythmic modules exhibit an interesting pattern: most notable is the symmetry demonstrated by modules A, B, and C. Each module is composed of three durations; the outer durations are clearly identical while the inner is discrete. Non-retrogradable rhythms are commonplace in Messiaen’s music, but these particular modules share an additional feature: close examination reveals that they all share a 2:1:2 ratio of durations. The sole difference is the augmentation or diminution of rhythmic values contained within the set. Modules A, B and C clearly demonstrate this ratio of durations.

<sup>19</sup> Ian Darbyshire, “Messiaen and the Representation of the Theological Illusion of Time,” in *Messiaen’s Language of Mystical Love*, ed. Siglind Bruhn (London: Garland Publishing, 1998), 39.

Module D is a variation on the aforementioned model. Its general proportions are generated through an augmentation of the C module that increases each value by one quarter of its original rhythmic value. Messiaen then splits the first two values by separating the augmentation from the original duration so that a total of five separate values constitute the D module. This variation on the overarching 2:1:2 rhythmic idea reflects a calculated effort to prolong and modify the alignment of the *talea* and *color* by offsetting the basic relationship between their relative cardinalities.<sup>20</sup> By splitting a three-member module into a set of five values, Messiaen reorganizes the juxtaposition of both dimensions—*talea* and *color*—so that their respective alignment reflects a more complex ratio.

Module E stands alone as a non-retrogradable rhythmic module composed of 15 durations.<sup>21</sup> Module D therefore serves as a means of bridging the gap between the E module and the uniform modules A, B, and C. Based on attack, the E module does not articulate an overarching structure based on the proportions 2:1:2, thus it is the sole “micro“ module that isn’t based on a common template. Figure 1.3 illustrates the principal texture of the composition with the aforementioned rhythmic modules in both hands of piano 1, while piano 2 develops the creation theme.<sup>22</sup> The creation theme is detailed in figure 1.2.

---

<sup>20</sup> This assertion takes into consideration the three-member colors of the right and left hand. Unaltered, this results in perfect alignment with a basic 2:1:2 ratio of durations. An opposing argument in favor of Trinitarian symbolism would suggest the variation is a means of breaking away from the three-duration module—thus preserving three groups of three durations, as opposed to four.

<sup>21</sup> Labeled “D” by Messiaen in the *Traité de Rythme, de Couleur, et d’Ornithologie*, II (Paris: Alphonse Leduc, 1995), 56.

<sup>22</sup> For an explanation of piano 2, see section III: “Thematic Development,” 56.

Figure 1.2. The creation theme, mm. 9–16.

Figure 1.2 shows two systems of piano accompaniment. Each system consists of two staves in bass clef with a key signature of two sharps (F# and C#). The music features dense chordal textures and rhythmic patterns, including some notes with fermatas.

Figure 1.3. Rhythmic modules (piano 1) and creation theme (piano 2).

Figure 1.3 shows rhythmic modules for Piano 1 and Piano 2. Piano 1 has two staves (treble and bass clef) with a key signature of two sharps. It includes sections labeled "X Module", "A.", "B.", and "Break (5 Beats)". Piano 2 has two staves in bass clef with a key signature of two sharps, labeled "Theme Instance #2" and "(2 Measure Repeated Unit)". A bracket underlines the first four measures of Piano 2.

Messiaen draws attention to these modules by bracketing them and providing a letter name for each of the referenced rhythmic patterns. The subsequent ordering of these modules into larger groups of rhythmic organization produces compound, retrogradable structures that repeat as a single unit.<sup>23</sup> The combination of modules A, B, C, D, and E into larger groups of fixed order represents what may be referred to as the middle stratum of rhythmic design. In the right hand, modules A and B occur in immediate proximity, followed by brief interruptions of uniform activity in eighth notes. In the left hand, modules C, D, and E form the succession C, D, C, D, E—a compound module that persists throughout the left hand part. Core middle stratum patterns <AB> and <CDCDE> unfold according to an even higher level of temporal organization—the background stratum, or largest repeating unit of rhythm; composed of a pattern of <AB>, <CDCDE>, and the uniform space between them.

These various levels of rhythmic patterns organize the accompaniment of piano 1 in “Amen de la Création.” At the deepest structural level, a process in the background stratum will terminate the movement after its final (and in this case, third) complete statement, reinforcing its role as a constructive principle.<sup>24</sup> As shown by Messiaen’s own annotations, instances of arranged modules like <AB> and <CDCDE> continuously progress without interruption. The space between iterations of the <AB> module is composed of uniform

---

<sup>23</sup> Referred to as the higher, or overarching, ostinato, “l’ostinato supérieur,” in Olivier Messiaen, *Traité de Rythme, de Couleur, et d’Ornithologie*, II (Paris: Alphonse Leduc, 1995), 57.

<sup>24</sup> In the movement “Les sept Anges aux sept trompettes” in *Éclairs sur L’Au-Delà*, a rhythmic module comprising three distinct sounds (bass drum, cymbals/gongs/tam tam, and a whip) and seven total durations is the object of a cyclic process. The rhythmic process terminates after the 21<sup>st</sup> cycle—a number presumably generated by the multiplication of the two sacred numbers in play, three and seven). See Christopher Dingle, “Sacred Machines: Fear, Mystery and Transfiguration in Messiaen’s Mechanical Procedures,” in *Messiaen Perspectives 2: Techniques, Influence and Reception*, eds. Christopher Dingle and Robert Fallon (Surrey, UK, and Burlington, Vt.: Ashgate Publishing, 2013), 19–20.

eighth notes, in which case the homogeneity of duration does not constitute a rhythmic module per se.<sup>25</sup> The amount of time elapsed during these interruptions does, however, reveal a consistency indicative of a larger repeating pattern of rhythmic units: the background. Inspection of the durations between statements of the <AB> module reveals the following pattern: (5 beats, 5 beats, 20 beats) (5 beats, 5 beats, 20 beats) (5 beats, 5 beats, 20 beats). The bracketed material encloses a repeating background unit, which is stated a total of three times. The introduction of middle stratum material (fixed patterns of the rhythmic subunits) into this organization reinforces the integrity of this background structure and affirms the role played by its termination at the end of the movement (see figure 1.3). The following repeated background pattern, dubbed the X module, emerges when the mid-stratum is arranged into the pattern: (1) <AB>, 5 beats; <AB>, 5 beats; <AB>, 20 beats; <AB>, 2 beats rest; (2) <AB>, 5 beats; <AB>, 5 beats; <AB>, 20 beats; <AB>, 2 beats rest; (3) <AB>, 5 beats; <AB>, 5 beats; <AB>, 20 beats; <AB>, 2 beats rest.<sup>26</sup>

---

<sup>25</sup> These periods of straight eighth notes are accented according to ancient Greek rhythms. While the 20 beat pattern concludes with new rhythmic patterns and subdivisions, and is retrogradable, the 5 beat pattern is accented 2+1+2, similar to modules A, B, and C. Olivier Messiaen, *Traité de Rythme, de Couleur, et d'Ornithologie*, III (Paris: Alphonse Leduc, 1996), 252.

<sup>26</sup> Numbers in parentheses correspond to each repetition of the X module.

Figure 1.4. Background structure of the rhythmic modules in “Amen de la Création.”

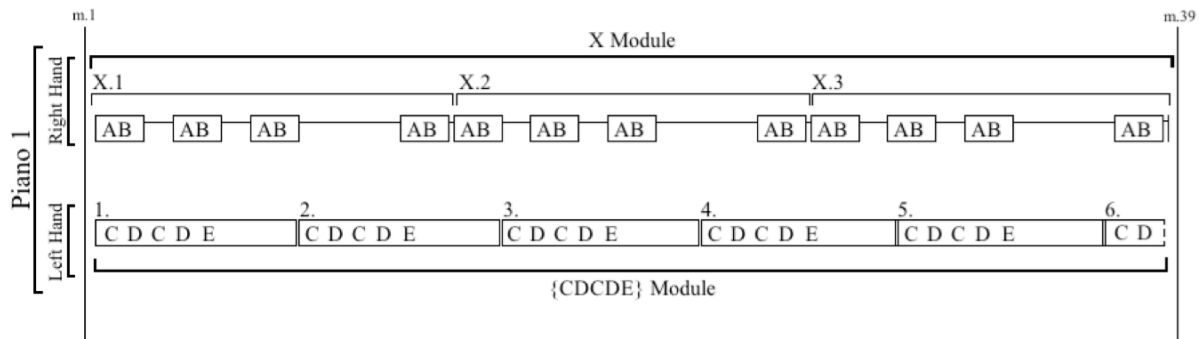

While the conclusion of this repeated sequence coincides with the end of the movement, the <CDCDE> module terminates prematurely. Subordinate to the time strictures imposed by a three-fold repetition of the X module, the <CDCDE> module operates on a purely middle stratum gradation; Messiaen’s treatment of the module does not suggest any long-term projections. While the periodicity of the creation theme in piano 2 provides a sense of measured time, the juxtaposition of non-retrogradable and asymmetric rhythmic modules in piano 1 results in an immeasurable, unpredictable sensation of time—a force that historian Steven Schloesser describes as “the kind of freedom and seeming improvisation exhibited by the Creator in Genesis.”<sup>27</sup> This assertion is strengthened by Messiaen’s own comments in the first volume of the *Traité*:

Time is the measure of creation, eternity is God himself. Eternity is indivisible like God is divisible. Time is not a finite length that enters into an infinite length (Eternity): it is continuous in the face of the indivisible (God).<sup>28</sup>

<sup>27</sup> Stephen Schloesser, *Visions of Amen: The Early Life and Music of Olivier Messiaen* (Grand Rapids: William B. Eerdmans Publishing, 2014), 305.

<sup>28</sup> Melody Baggech, “An English Translation of Olivier Messiaen’s *Traité de Rythme, de Couleur, et d’Ornithologie*, volume 1” (D.M.A. diss., University of Oklahoma, 1998), 15.

He goes on to say, in more direct terms, “Eternity is God himself.”<sup>29</sup> Piano 1 has already been established as a vehicle of true time—eternity, so to speak. The division of this “immeasurable” timeline into three equal parts reveals the true nature of eternity: the Trinity, God. Messiaen perhaps best describes his contemplations on, and subsequent comprehension of, time:

Time has always been at the center of my preoccupations. As a rhythmicist, I’ve endeavored to divide this time up and to understand it better by dividing it. Without musicians, time would be much less understood. Philosophers are less advanced in this field, but as composers, we have the great power to chop up and “retrograde” time.<sup>30</sup>

Messiaen recasts the role of *talea* in the final movement, “Amen de la Consommation.” In this movement, the process does not continuously unfold over the course of the movement, but is instead subordinate to an intricate process of rotations.<sup>31</sup> This distinction becomes readily apparent when the right hand and left hand are compared, as both hands share the same *talea* as it moves in a canon, detailed in figure 1.5. The difference, then, relies on the rhythmic displacement between simultaneous *taleae*, which generates a total of three composite rhythms. The resultant superimposed *taleae* will be referred to as “phases,” as their alignment is subject to a linear process that gradually repositions two identical components. The three resultant composite phases are defined as

---

<sup>29</sup> Ibid., 17.

<sup>30</sup> Claude Samuel, *Olivier Messiaen: Music and Color: Conversations with Claude Samuel*, trans. E. Thomas Glasow (Paris: Belfond, 1986), 34, quoted in Ian Darbyshire, “Messiaen and the Representation of the Theological Illusion of Time,” *Messiaen’s Language of Mysical Love*, ed. Siglind Bruhn (New York and London: Garland Publishing, 1998), 35. Darbyshire uses the word “retrograde” here in lieu of Glasow’s translation of the word “rétrograder,” which he translated as “altered” in his original text.

<sup>31</sup> The term “rotation” will be used to describe a cyclic permutation of chords in a fixed order.

follows: phase I (five successive repetitions, second *talea* displaced by a half note rest); phase 2 (six successive repetitions, second *talea* displaced by a quarter note rest); phase 3 (three separate repetitions, second *talea* displaced by an eighth note rest).<sup>32</sup> While the composite rhythms prove interesting, their significance lies in the clearly defined process of displacement.

Figure 1.5. Linear displacement of juxtaposed *taleae*, or phases, of the canon.

## II. *Color*: Rotation and Permutation

Returning to the rhythmic structures of piano 1 in “Amen de la Création,” the dimension of *color* will now be superimposed on the middle stratum. While the rhythmic patterns of the *talea* prove to be sizable (one repeating module of 55 durations, and another of 31 durations), the *color* sets are quite compact: a total of three chords make up the *color* for the right hand, and an additional three chords constitute the left hand. Each chord collection unfolds without interruption, relying on the drawn-out rhythms of each *talea* in order to generate surface level variations in time and pitch.

<sup>32</sup> With each successive repetition of the final phase the overall length of the canon is truncated. Each of these successive repetitions do, however, begin both parts displaced by an eighth note.

Figure 2.1. “Amen de la Création,” piano 1, reduction of *color* in both hands.

|             |               |                |                 |
|-------------|---------------|----------------|-----------------|
| Collections | (012678)      | (012678)       | (012678)        |
| Juxtaposed  | [1,2,3,7,8,9] | [5,6,7,11,0,1] | [3,4,5,9,10,11] |

The significance of a three-chord *color* should not be neglected, as the three-fold repetition of the X module has already played an integral role in defining the total length of the movement. The role of piano 1 as an agency of “free time” provides a medium through which the creation theme of piano 2 is brought into existence. From the timeless expanses of nothing, permeated with the presence of three (suggestive of the Holy Trinity), a theme takes shape and is born. Messiaen’s minimal *color* of only three chords, in addition to the three-fold repetition of the X module as the temporal skeleton for the creation narrative, hints at a lucid representation of the Holy Trinity.

While the difference between each chord within a *color* is a change in pitch class content, the set class parallels between *color* members I, II, and III in both the right hand and left hand echo earlier indications of a “transfiguration” model. Figure 2.1 reveals a straightforward correspondence between the two collections—each *color* chord is actually a transposition of single chord; subsequent elements are generated by the uniform transposition of that chord. Even without careful calculation of the interval content of each chord, the morphology expressed between the two collections reveals a mirror relationship, or inversion. Thus the world of harmony generated by Messiaen in “Amen de la Création”

emanates from a chord belonging to set class (016) as it is inverted, transposed and superimposed onto itself in order to form instances of (012678). The three members of each *color* are produced by the transfiguration of one unifying chordal body, strengthening earlier observations of Trinitarian parallels.

The creation narrative supplies a great deal of palpable material from which the processes in “Amen de la Création” are shaped (or at least described, in accordance with the narrative). In the final movement of the piece, “Amen de la Consommation,” Messiaen reintroduces familiar compositional idioms, yet varies the respective processes below the surface level, reflecting the composition’s growth. As established in the first movement, the *color* collections of piano 1 can be reduced to a fundamental unit of three members. First introduced in figure 1.5, the *talea* “phase” onto which the following *color* collections are imposed can be divided into three unique instances based on displacement of the original rhythm. This rhythmic pattern is presented in figure 2.2a, while an example of the rhythmic canon (first phase) is presented in figure 2.2b. The process yields three rhythmic variations: phases displaced by a half note, quarter note, and eighth note rest, respectively (as detailed earlier in figure 1.5). This process is also overlaid by a three-part series of rotations in the *color*.

Figure 2.2. Aspects of the *talea* phase.

A. Base rhythm of the rhythmic canon.



B. The rhythmic canon, first phase, “Amen de la Consommation,” mm. 1–2.

The musical score shows two staves. The top staff is in treble clef and contains a sequence of chords. A bracket below the first two chords is labeled "2 Beats". The bottom staff is in bass clef and contains a sequence of notes and chords. A bracket below the first two notes is labeled "2 Beats". The key signature has one sharp (F#) and one flat (Bb).

In the right hand, each phase of the rhythmic canon begins with a new  $T_4$  transposition of the previous three-chord collection, detailed in figure 2.4. Once set in motion, the principal *taleae* in the first phase of juxtaposition (figure 1.5) co-evolve without interruption until each *talea* is stated five times. The second phase begins in a similar fashion, with the left hand rotated below a newly transposed set of three (01268) set class chords, this time for a total of six repetitions. The third phase is slightly different; while the first two rhythmic canons repeat the principal rhythmic module without interruption, the third phase is broken into three separate statements. With each successive statement, the principal rhythmic module is truncated as the left hand continues to rotate cyclically over the course of each statement. The sole exception to this pattern is the final statement, where the cyclic rotation of the left hand part moves in retrograde to a previous state (figure 2.4). This abnormality coincides with the final statement of the three that constitutes the third phase. While the collection of the right hand remains stable throughout each statement of the third phase, the three-fold repetition of the phase offsets the cyclic rotation of the left

hand, instigating a retrogradation. This change prompts the termination of the rhythmic canon as an accompaniment.<sup>33</sup>

Figure 2.3. “Amen de la Consommation,” left hand rotations beneath first color collection in piano 1, mm. 38–52.

RH

LH

I II III

(01268) (01268) (01268)

[7,8,9,1,3] [5,6,7,11,1] [3,4,5,9,11]

Figure 2.4. “Amen de la Consommation,” reduction of left hand rotations beneath right hand *color* of piano 1 in each phase of rhythmic canon.

Talea Phase 1. 2. 3.

[3,4,5,6,7,8,9,11,1] T4 [7,8,9,10,11,0,1,3,5] T4 [11,0,1,2,3,4,5,7,9]

LH Rotation I II III II III I III I II I II III III I II

\* Full Rotation Retrogradation

<sup>33</sup> Messiaen continues to paraphrase short rhythmic canons in the following music, which are much shorter and become homophonic at times. These canons are based on new rhythms and not bracketed as rhythmic canons (mm. 52, 60, 62 and 65).

### III. Thematic Development

As discussed in the opening, the outer movements enclose the composition between statements of similar thematic material: the creation theme.<sup>34</sup> Messiaen recounts the thematic narrative in aesthetic terms as it is conceived in the first movement. He describes a primordial body of distorted, unrecognizable chords in the low register of the piano; a pattern of contours begins to form an emerging theme.<sup>35</sup> The direct parallels between this inception and the narrative of creation are readily apparent, yet a prolonged, matured form of the theme becomes the product of a distinguished operation in the final movement. Under the veil of God's creative faculty, the composition is set in motion by God's creation of all things and is concluded by His resurrection of glorified bodies, granting them new life, foreshadowing the paradise to come.

The initial formation of the creation theme in the first movement is relatively uniform compared to that of the final movement, in which the transfiguration and creation of man anew—*so to speak*—proves to be an onerous task. Figure 3.1 illustrates the development of the theme, with pitch class and ordered pitch interval numbers denoting repeated patterns. The patterns exhibited by each sub-phrase conform to a larger structural pattern that encompasses all sub-phrases, which are indicated in the figure by groups A and B.

---

<sup>34</sup> See figure 1.2 for example of the theme as it appears in the score.

<sup>35</sup> Oliver Messiaen, "Note de l'Auteur," *Visions de l'Amen* (Paris: Durand, 1943), n.pag.

Figure 3.1. “Amen de la Création,” thematic development.

|       | Instance | Subdivided | Pitch Class         | OPI                    |
|-------|----------|------------|---------------------|------------------------|
| m. 1  | A        | 1          | 9, 1, t, 9, 4       | +4, -3, -1, +7         |
|       |          | 2          | 4, 6, 4, e, 2       | +2, -2, -5, +3         |
|       |          | 3          | 2, 4, 2, 8, e       | +2, -2, -6, +3         |
|       |          | 4          | e, 1, e, 4, 6, 9    | +2, -2, -7, +2, +3     |
| m. 8  | A        | 5          | 9, 1, t, 9, 4       | +4, -3, -1, +7         |
|       |          | 6          | 9, t, 9, 2, 5       | +3, -3, -7, +3         |
|       |          | 7          | 2, 4, 2, 8, e       | +2, -2, -6, +3         |
|       |          | 8          | e, 1, e, 4, 6, 9    | +2, -2, -7, +2, +3     |
| m. 17 | A        | 9          | 9, 1, t, 9, 4       | +4, -3, -1, +7         |
|       |          | 10         | 4, 6, 4, e, 2       | +2, -2, -5, +3         |
|       |          | 11         | 2, 4, 2, 8, e       | +2, -2, -6, +3         |
|       |          | 12         | e, 1, e, 4, 6, 9    | +2, -2, -7, +2, +3     |
| m. 25 | B        | 13         | e, 6, 4, e, 9       | -5, -2, +7, -2         |
|       |          | 14         | e, 6, 4, e, 9       | -5, -2, +7, -2         |
|       |          | 15         | e, 6, 4, e, 9, 1, 4 | -5, -2, +7, -2, +2, +3 |
|       |          | 16         | e, 6, 4, e, 9       | -5, -2, +7, -2         |
|       |          | 17         | 6, 4, e, 9, 4, e    | -2, +7, -2, +7, -5     |
|       |          | 18         | 6, 4, 2, 4          | -2, -2, +2             |

Despite contrasting intervallic patterns, phrases of the A group share a common contour: a mutual “up, down, down, up” profile that implies the presence of the creation theme despite subtle variations in pitch and interval.<sup>36</sup> This distinction becomes crucial in maintaining a sense of regularity as the theme is subject to a great deal of transformation in the final movement, but the uniform manner in which the theme is executed in this movement presents no difficulties in reception.

The first movement comprises three complete iterations of the A group, previously referred to as the creation theme. This group shows prominence in the final movement of the piece, but due to a series of variations, is primarily identified by its initial subdivision:

---

<sup>36</sup> For the sake of comprehensiveness, the use of OPI rather than IC distinguishes between P4 and P5 so that patterns of 5 and 7 may accurately convey the contours of the theme and produce more intimate patterns.

ordered pitch intervals  $\langle +4, -3, -1, +7 \rangle$ . Group B introduces a contrasting set of ordered pitch intervals loosely based on the final subdivided phrase of group A. Modest variations occur in each subsection of B, but conform to the rules and features of the group as a whole. Generally, the sub-phrases of the B group conform to a “down, down, up, down” contour. Some statements, like the sub-phrases 15 and 17, imitate the six-note sub-phrase of the A section (marked “subdivision 4” in each boxed statement of A). For example, the extension  $\langle +7, -5 \rangle$  in the second subdivision of group B imitates those six-note phrases of the A group, although the motion is not passing but instead returning—a leap of a perfect fifth is reflected in contrary motion by a perfect fourth. This motion embellishes the upward movement of a whole step, which is consistent with the conventions of group B.

The creation theme reappears under a different guise in the final movement. With groups A and B already identified, their return in the developing theme supplies several placemarkers for discerning large-scale repeating phrase patterns. Bearing in mind the habitual significance of groups A and B, the overarching structure is divided into five sections arranged chiastic fashion, as illustrated in figure 3.2. This division of the section into five parts is significant—the carillon of light, which continually exhibits influence of the divine, makes a return in this movement. In the prefatory notes to the score, Messiaen describes the movement as the “life of glorified bodies in a carillon of light.”<sup>37</sup> Stephen Schloesser suggests that Messiaen’s encounter with a sermon based on Thomas Aquinas’s *Glorified Bodies* influenced his interpretation of the transfiguration during the time he was

---

<sup>37</sup> Oliver Messiaen, “Note de l’Auteur,” *Visions de l’Amen* (Paris: Durand, 1943), n.pag.

composing *Visions*.<sup>38</sup> He places particular emphasis on a passage that states, “the adoption of the sons of God [i.e., filiation] through a certain conformity of image to the natural Son of God.”<sup>39</sup> This is quite significant, since the phrase groups of the thematic development section conform to a semi-symmetrical model comprising five sections as God creates mankind anew in his own image—recalling earlier discussions regarding the number five, this “glorified mankind” possesses both duality and the Holy Spirit: 2 + 3.

Each large-scale division includes an additional theme group that demonstrates a contrasting process. In the first section, an additional group, C, follows the first iteration of the A group. The second section restates the A group, now followed by the B group as it had in the first movement. The third section features a return of the C group, with the addition of a new group labeled D, which is an unfamiliar pattern of intervals and new texture (the foreground theme, now harmonized in dyads). The fourth section is a repetition of the second section. The final section begins with a three-fold statement of the A group’s primary identifying gesture,  $\langle +4, -3, -1, +7 \rangle$ , which is followed by the E group (or closing / coda), which is composed of fragments closely related to the A and B groups and is constantly undergoing a process of permutation. Numbers in parentheses indicate overlapped tones, in which case their respective phrase is elided with another, resulting in a compound phrase.<sup>40</sup>

---

<sup>38</sup> Messiaen also makes reference to this particular sermon while discussing his work *La Transfiguration de Notre Seigneur Jésus-Christ*, a work comprising two septanaries (seven-movement forms). Olivier Messiaen and Claude Samuel, *Music and Color: Conversations with Claude Samuel*, trans. Thomas E. Glasow (Portland: Amadeus Press, 1994), 145.

<sup>39</sup> Thomas Aquinas, *Summa Theologica*, IIIa, q. 45, a. 4, as quoted in Stephen Schloesser, *Visions of Amen: The Early Life and Music of Olivier Messiaen* (Grand Rapids: William B. Eerdmans Publishing, 2014), 441.

<sup>40</sup> By showing the overlapped tone, the interval between elided phrases is also shown.

Groups A, B, C, and D all demonstrate a satisfactory degree of uniformity within their internal components. The final process, group E, significantly develops and recalls previously stated thematic material as the conclusion quickly approaches. Each statement of the theme overlaps with the following, and consequently, the previous. For instance, the final note of a statement becomes the first note of the subsequent phrase (figure 3.2, group E, indicated in parentheses) so that nearly the entire theme group is intertwined in this fashion. The thoroughgoing mechanism of group E recasts melodic fragments native to groups A and B,<sup>41</sup> with their best-preserved form found closer to the start of the process. The latter portion of the group amplifies the variation procedure, no longer yielding any familiar fragments but rather anticipating the final statement through an excited irregularity. The projected goal is an arrival at pc 9, from which the creation theme was first initiated in “Amen de la Création.”<sup>42</sup>

---

<sup>41</sup> Melodic fragments are determined according to similarities between initial statements of each group, overall periodicity, and relationships exhibited between subdivided phrases within a group.

<sup>42</sup> While the piece is written in a fashion that warrants no key signature, it is significant that Messiaen chooses to end the piece on pc 9, as the key signature indicates A major. While the key signature is dispensable, it should be noted that it contains three sharps.

Figure 3.2. Thematic development in “Amen de la consommation.”

| I        |            |                  |                     |
|----------|------------|------------------|---------------------|
| Instance | Subdivided | Pitch Class      | OPI                 |
| 1        | 1          | 9, 1, t, 9, 4    | +4, -3, -1, +7      |
| 2        | 2          | 4, 6, 4, e, 2    | +2, -2, -5, +3      |
| 3        | 3          | 2, 4, 2, 8, e    | +2, -2, -6, +3      |
| 4        | 4          | e, 1, e, 4, 6, 9 | +2, -2, -7, +2, +3  |
| 5        | 5          | 9, 1, t, 9, 4, 4 | +4, -3, -1, +7, +12 |
| 6        | 6          | 9, t, 9, 2, 5    | +2, -2, -7, +3      |
| 7        | 3          | 5, 7, 5, 9, (0)  | +2, -2, -8, (+3)    |
| 8        | 4          | 0, 2, 0, 4, (7)  | +2, -2, -8, (+3)    |
| 9        | 5          | 7, e, 7, 2, (5)  | +4, -4, -5, (+3)    |
| 10       | 6          | 5, 8, 5, e, 1, 4 | +3, -3, -6, +1, +5  |

| II       |            |                     |                        |
|----------|------------|---------------------|------------------------|
| Instance | Subdivided | Pitch Class         | OPI                    |
| 11       | 1          | 1, 5, 2, 1, 8       | +4, -3, -1, +7         |
| 12       | 2          | 8, t, 8, 3, 6       | +2, -2, -5, +3         |
| 13       | 3          | 6, 8, 6, 0, 3       | +2, -2, -6, +3         |
| 14       | 4          | 3, 5, 3, 8, t, 1    | +2, -2, -7, +2, +3     |
| 15       | 1          | 3, t, 8, 3, 1       | -5, -2, +7, -2         |
| 16       | 1          | 3, t, 8, 5, 1       | -5, -2, +9, -4         |
| 17       | 2          | 3, 1, 8, 3, 1, 5, 8 | -5, -2, +7, -2, +4, +3 |
| 18       | 1          | 3, t, 8, 3          | -5, -2, +7             |
| 19       | 2          | t, 8, 3, 1, 8, 3    | -2, +7, -2, +7, -5     |
| 20       | 3          | t, 8, 6, 8          | -2, -2, +2             |

| III      |            |                     |                        |
|----------|------------|---------------------|------------------------|
| Instance | Subdivided | Pitch Class         | OPI                    |
| 21       | 1          | 5, 9, 6, 5, (0)     | +4, -3, -1, (+7)       |
| 22       | 2          | 0, 2, 0, 7, (t)     | +2, -2, -5, (+3)       |
| 23       | 3          | t, 0, t, 4, (7)     | +2, -2, -6, (+3)       |
| 24       | 4          | 7, 9, 7, 0, 2, (5)  | +2, -2, -7, +2, (+3)   |
| 25       | 5          | 5, 9, 6, 5, (5)     | +4, -3, -1, (+12)      |
| 26       | 4          | 5, 7, 5, t, (1)     | +2, -2, -7, (+3)       |
| 27       | 1          | 1, 3, 1, 5, (8)     | +2, -2, -8, (+3)       |
| 28       | 2          | 8, t, 8, 1, (3)     | +2, -2, -8, (+3)       |
| 29       | 3          | 3, 7, 3, t, (1)     | +4, -4, -5, (+3)       |
| 30       | 4          | 1, 4, 1, 7, 8, t, 0 | +3, -3, -6, +1, +2, +2 |
| 31       |            | 7, 3, 1, 7, 6       | +8, -2, -6, +10        |
| 32       |            | e, 5, 3, e, 8       | +6, -2, -4, +10        |
| 33       |            | 1, 7, 3, 9, 5       | +6, -4, +6, -4         |
| 34       |            | 5, e, 9, 3, 3       | +6, -2, -6, +12        |
| 35       |            | 4, 0, 6, 2, 8       | +8, -7, +8, -6         |
| 36       |            | 8, 4, 3, t, 0, 2, 4 | +8, -1, -5, +2, +2, +2 |
| 37       |            | t, 0, 2, 4          | +2, +2, +2             |
| 38       |            | e, 0, 2, 4          | +1, +2, +2             |
| 39       |            | e, 0, 2, 4          | +1, +2, +2             |

| IV       |            |                     |                         |
|----------|------------|---------------------|-------------------------|
| Instance | Subdivided | Pitch Class         | OPI                     |
| 40       | 1          | 9, 1, t, 9, 4       | +4, -3, -1, +7          |
| 41       | 2          | 4, 6, 4, e, 2       | +2, -2, -5, +3          |
| 42       | 3          | 2, 4, 2, 8, e       | +2, -2, -6, +3          |
| 43       | 4          | e, 1, e, 4, 6, 9    | +2, -2, -7, +2, +3      |
| 44       | 1          | e, 6, 4, e, 9       | -5, -2, +7, -2          |
| 45       | 1          | e, 6, 4, 1, 9       | -5, -2, +9, -3          |
| 46       | 2          | e, 6, 4, e, 9, 1, 1 | -5, -2, +7, -2, +4, +12 |
| 47       | 1          | e, 6, 4, e          | -5, -2, +7              |
| 48       | 2          | 6, 4, e, 9, 4, e    | -2, +7, -2, +7, -5      |
| 49       | 3          | 6, 4, 2, 4          | -2, -2, +2              |

| V        |            |                  |                   |
|----------|------------|------------------|-------------------|
| Instance | Subdivided | Pitch Class      | OPI               |
| 50       | 1          | 9, 1, t, 9, 4    | +4, -3, -1, +7    |
| 51       | 1          | 9, 1, t, 9, 4    | +4, -3, -1, +7    |
| 52       | 1          | 9, 1, t, 9, 4    | +4, -3, -1, +7    |
| 53       |            | 4, 1, t, 9, (9)  | -3, -3, -1, (+12) |
| 54       |            | 9, 8, 6, 9, (4)  | -1, -2, +3, (-5)  |
| 55       |            | 4, 3, 1, t, (9)  | -1, -2, -3, (-1)  |
| 56       |            | 9, 1, t, 9, (4)  | +4, -3, -1, (+7)  |
| 57       |            | 4, 1, t, 9, (9)  | -3, -3, -1, (+12) |
| 58       |            | 9, e, 9, 6, (2)  | +2, -2, -3, (-4)  |
| 59       |            | 2, 3, 5, 9, (4)  | +2, +2, +4, (-5)  |
| 60       |            | 4, 3, 1, 10, (6) | -1, -2, -3, (-4)  |
| 61       |            | 6, 7, 9, 4, (e)  | +1, +2, +7, (-5)  |
| 62       |            | e, 6, 4, e, (6)  | -5, -2, +7, (-5)  |
| 63       |            | 6, 4, e, 1, (6)  | -2, +7, +2, (-7)  |
| 64       |            | 6, 4, 1, e, (4)  | -2, +9, -2, (-7)  |
| 65       |            | 6, 4, e          | -2, -5            |
| 66       |            | 9, 1, t, 9       | +4, -3, -1        |
| 67       |            | 4, 9, 7, 4       | +5, +2, -3        |
| 68       |            | t, 9, 0, 6, (1)  | -1, +3, +6, (-5)  |
| 69       |            | 1, 3, 4, 9 (7)   | +2, +1, +5, (-2)  |
| 70       |            | 7, 3, 4, t, (6)  | -4, +1, +6, (-4)  |
| 71       |            | 6, 7, 9, 0, (4)  | +1, +2, +3, (+4)  |
| 72       |            | 4, 1, t, 3, (7)  | -3, -3, +5, (+4)  |
| 73       |            | 7, 1, 6, 3, (9)  | -6, +5, -3, (-6)  |
| 74       |            | 9, 0, 7, 9, (t)  | +3, -5, +2, (+1)  |
| 75       |            | t, 0, 1, 4, (3)  | +2, +1, +3, (-1)  |
| 76       |            | 3, 4, 6, 7, 9    | +1, +2, +1, +2    |

| Symmetrical Layout |    |     |    |   |
|--------------------|----|-----|----|---|
| I                  | II | III | IV | V |
| A                  | A  | A   | A  | A |
| C                  | B  | C   | B  | E |
|                    |    | D   |    |   |

The first and final movements of Messiaen's *Visions de l'Amen* share more than just sensible compositional preparation. The application of prolonged rhythmic structures overlaid with short, repeated pitch collections generates a sensation of timelessness and indeterminacy. The resultant sonic environment houses both prominent instances of the creation theme, as Messiaen's implied symbolism reveals even deeper significance than a purely aesthetic representation of his subject. The collections of chords used for *color* are an intimate extension of the Trinitarian, symbolic qualities first noted in the rhythmic processes. The categorical layout of thematic events as they mature establishes symmetry as a principal, recurring facet of the compositional whole. Both the composer's penchant for hyperbolic description and his reputation as a reverent Catholic provide evidence upon which the significance of three, five and seven is supported. While the foregoing analysis examines rhythmic anatomy overlaid with *color* processes, and the development of a mutual theme between movements, the recurring presence of the numbers three, five and seven as they apply to each parameter of analysis invites—if not *welcomes*—an argument for both Trinitarian parallelism and symmetry. In a conversation with Almut Rößler, Messiaen remarked:

Generally speaking, I've allowed my thoughts to revolve around a specific subject—a mystery of the Christian faith, such as the birth of our Lord or his Resurrection, or else a mystery of the Holy Spirit such as the Feast of Pentecost; and in the Bible, in writings of the fathers of the Early Church or in the other religious texts, but above all in the Holy Scriptures, I've tried to find everything which has to do with the subject I've chosen and then have tried to translate it into music—not just into notes, not just into sounds and rhythms, but into sound-colors as well.<sup>43</sup>

---

<sup>43</sup> Almut Rößler, *Contributions to the Spiritual World of Olivier Messiaen* (Duisburg: Gilles & Francke, 1986), 28.

Recall the three sets of three-duration rhythmic modules A, B and C; the three-fold repetition of module X as the temporal backbone for the first movement; the three chord *colores* of the first movement, with both collections generated from a single chord and its respective inversion; the three different “phases” of juxtaposed *taleae* in the final movement and corresponding three-stage *color* rotation scheme that runs concurrent with the three-fold repetition of the final *talea* phase; and finally, the three complete statements of the creation theme (or A group) in the first movement, as well as the symmetrical arrangement of five overarching sections of thematic development in the final movement. Such patterns affirm the indisputable role of both three and symmetry as a regulating factors in all foregoing dimensions. While use of Trinitarian parallels in Messiaen’s extended œuvre warrants further exploration, the capacity of three-fold repetition and chiasmic structures as governing forces in the first and final movements of *Visions de l’Amen* substantiates this assertion beyond a reasonable doubt.

## **Part II - The Nested Movements, Symmetry, and Space**

While the outer movements of *Visions de l’Amen* are clearly related, the inner house their own distinct thematic material. Occasionally, themes are briefly paraphrased in other movements. The creation theme, which returns briefly in the coda of the third movement, provides motivic material for the second phrase in the fifth movement.<sup>44</sup> They do, however, share mechanisms already observed—*talea* and *color*, three and five-part forms, and symmetrical structures found in both rhythm and pitch. These aspects often occur

---

<sup>44</sup> Olivier Messiaen, *Traité de Rythme, de Couleur, et d’Ornithologie*, III (Paris: Alphonse Leduc, 1996), 252.

simultaneously as if they function in the service of an overarching compositional objective: “bringing to life” the theological narrative.

While Messiaen’s seven-movement work *Méditations sur le mystère de la Sainte Trinité* (1969) is clearly arranged into a chiasmic form based on the subject of each movement,<sup>45</sup> this formal design is only loosely applicable to *Visions de l’Amen*.<sup>46</sup> Another seven-movement work, *Les Corps Glorieux* (1939), is also arranged around the central movement. In that piece, the fourth movement articulates the divide between life and death, bisecting the formal narrative into two halves: life, then death, respectively.<sup>47</sup> This type of symmetry, a 3 + 1 + 3 arrangement of movements, seems more likely in *Visions*. Rather than looking for thematic connections on both sides of the axis, Stephen Schloesser proposes a 3 + 1 + 3 model based on each movement’s setting in time: the first 3 movements are rooted in the past, the median movement resides in the present, and the final three movements anticipate the future.<sup>48</sup> While this explanation accounts for the temporal narrative of the piece, it should be stressed that both halves of the model are not necessarily opposed, since the similarities between the outer movements of *Visions*, already discussed at

---

<sup>45</sup> Anne Mary Keeley, “In the Beginning Was the Word? An Exploration of the Origins of *Méditations sur le Mystère de la Sainte Trinité*,” in *Messiaen Perspectives 1: Sources and Influences*, eds. Christopher Dingle and Robert Fallon (Surrey, UK, and Burlington, Vt.: Ashgate Publishing Limited, 2013), 182.

<sup>46</sup> Multiple studies have attempted to explain the symmetry behind the seven-movements of *Visions*, but so far no consensus has been reached. For additional information, see Paul Griffiths, *Olivier Messiaen and the Music of Time* (Ithaca: Cornell University Press, 1985), 108; Harry Halbreich, *Olivier Messiaen* (Paris: Fayard, 1980), 211; and Siglind Bruhn, *Contemplations of Covenant and Incantation* (Hillsdale: Pendragon Press, 2007), 123; Peter Hill, “Piano Music I,” in *The Messiaen Companion*, ed. Peter Hill (London: Faber and Faber, 1995), 80; Gareth Healey, *Messiaen’s Musical Techniques: The Composer’s View and Beyond* (Surrey, UK, and Burlington, Vt.: Ashgate Publishing Limited, 2013), 112–113.

<sup>47</sup> Almut Rößler, *Contributions to the Spiritual World of Olivier Messiaen* (Duisburg: Gilles & Francke, 1986), 29.

<sup>48</sup> Stephen Schloesser, *Visions of Amen: The Early Life and Music of Olivier Messiaen* (Grand Rapids: William B. Eerdmans Publishing, 2014), 365.

length in Part I, are quite clear. Symmetry is, however, less evident between the inner movements. Consider the subject of each movement—this would require the “Amen des étoiles, de la planète à l’anneau” to be consciously related to the “Amen du Jugement,” and that the movement addressing the “agony of Jesus” be thematically related to that of “angels, saints, and birdsong.”<sup>49</sup> Or, if the nature of symmetry were interlocking, movements II – V and III – VI would be similar. Messiaen’s original conception of the work before 1943 featured a total of five movements, centered around “Amen de l’Agonie de Jésus,” a scheme which did not include the eventual fourth or fifth movements, “Amen du Désir” and “Amen des anges, des saints, du chants des oiseaux.”<sup>50</sup> As a five-movement form, symmetry is subtly hinted at through Messiaen’s use of key signature—the outer movements are given the key signature of A major, while the inner movements are written in an open key.<sup>51</sup> The addition of these movements, in particular the “Amen du Désir,” seem to offset the previous formal plan in a significant way (including the symmetry of key signatures); the thematic connections between the inner movement and outer result in a more evident, audible, symmetrical plan.<sup>52</sup> While the seven-movement work clearly

---

<sup>49</sup> Siglind Bruhn enthusiastically suggests that the orientation of movements is, in fact, “perfectly symmetrical.” Her argument suggests that the middle movement, “Amen du Désir,” is the only movement thematically related to all other movements. For her explanation, see Siglind Bruhn, “The Centrality of Desire” in *Messiaen’s Contemplations of Covenant and Incarnation*, ed. Siglind Bruhn (Hillsdale: Pendragon Press, 2007), 117–126.

<sup>50</sup> This formal plan was first announced by Messiaen in a conversation with Denise Tual. Peter Hill and Nigel Simeone, *Messiaen* (New Haven: Yale University Press, 2005), 123.

<sup>51</sup> Thus the five-movement work exhibits the following sequence of key signatures: 3 #’s, open, open, open, 3 #’s. In light of the thematic narrative, the use of a key signature comprising three accidentals for the movements that highlight the Trinity is quite significant. Messiaen uses the same key for his triptych, *Trois Petites Liturgies de la Présence Divine*, written shortly after *Visions*.

<sup>52</sup> Robin Freeman argues that thematic material and birdsong used in the fourth and fifth movements of *Visions* foreshadow Messiaen’s following compositions, like the movement “Je dors mais mon cœur veille” in *Vingt regards sur l’Enfant-Jésus*, and the *Turangalila-Symphonie*. Robin Freeman, “Trompette d’un ange secret: Olivier Messiaen and the culture of ecstasy,” *Contemporary Music Review* 14, nos. 3–4 (August 2009): 98–99.

demonstrates a balance around its middle movement, a chiasmic or precisely symmetrical form is only loosely applicable. The connection between the outer movements does, however, strongly suggest a balanced form.

### **“Amen du Désir” as a fulcrum of formal design**

While the nature of symmetry exhibited by the order of the seven movements is open to discussion, the central movement, “Amen du Désir,” evidently functions as an axis or fulcrum. This, alongside the likeness of the outer movements, provides a basic structure that agrees with both explanations of symmetry;<sup>53</sup> the inner movement shares distinct qualities with the outer movements.

The themes of the fourth movement are largely independent, although the movement does contain several key qualities that connect it with the outer movements, especially with “Amen de la Création.” At m. 97, Messiaen reintroduces the carillon of light (the musical mechanism that operates under the same background rhythmic structure first demonstrated in figure 1.4). The temporal structure that organized the opening movement now returns, generated by the carillon. The ordering of rhythmic cells in both the X and <CDCDE> modules remains consistent. While the duration of the first movement was delineated by the three-fold repetition of the X module, the section of “Amen du Désir” that begins with the carillon of light also exhibits influence under the three-fold repetition of a theoretical X module.

---

<sup>53</sup> Both mirror symmetry and interlocking symmetry.

Unlike the first movement, where the X module sounds uninterrupted for three complete cycles, its return in the fourth movement is truncated shortly after just one complete cycle. This unfinished *talea* is interrupted by thematic material that emulates percussion (namely, drums and cymbals) which moves toward an eventual transition to the coda section.<sup>54</sup> While non-retrogradable rhythmic modules are no longer present on the level of perception, the background stratum of formal organization still plays a role in the overall length of the section.<sup>55</sup> The total length of “Amen de la Création” lasts 156 quarter notes, and comprises three X modules of 52 quarters length each. Enclosed between two sets of double barlines, the section in question lasts for 158 quarters—a single measure discrepancy between the two lengths.<sup>56</sup> The two sections begin with the same *talea* sequence, and span nearly identical lengths;<sup>57</sup> even in absentia the three-fold repetition of the X module still exerts influence on form as a temporal canvas. From m. 130 onward, the *talea* is no longer present in piano 2. While it seems unlikely that Messiaen would prematurely conclude the *talea* so early in the section, the model proposed in figure 4.1 suggests that the rhythmic device is merely relegated to the background; while its non-retrogradable rhythms are no longer present, its larger temporal structure (defined by three X modules) still determines form.

---

<sup>54</sup> Olivier Messiaen, *Traité de Rythme, de Couleur, et d’Ornithologie*, III (Paris: Alphonse Leduc, 1996), 254.

<sup>55</sup> For the background structure of “Amen de la Création,” see figure 1.4.

<sup>56</sup> One measure of 2/4.

<sup>57</sup> Both sections are nearly the exact same length in quarter notes. The two differ in *clock time*, as the tempo marking of the first section designates 25 bpm, and the latter 80 bpm. Despite the tempo change, both sections are proportionally alike (as written).

Figure 4.1. Temporal structure implied by three underlying X modules, mm. 97–175.

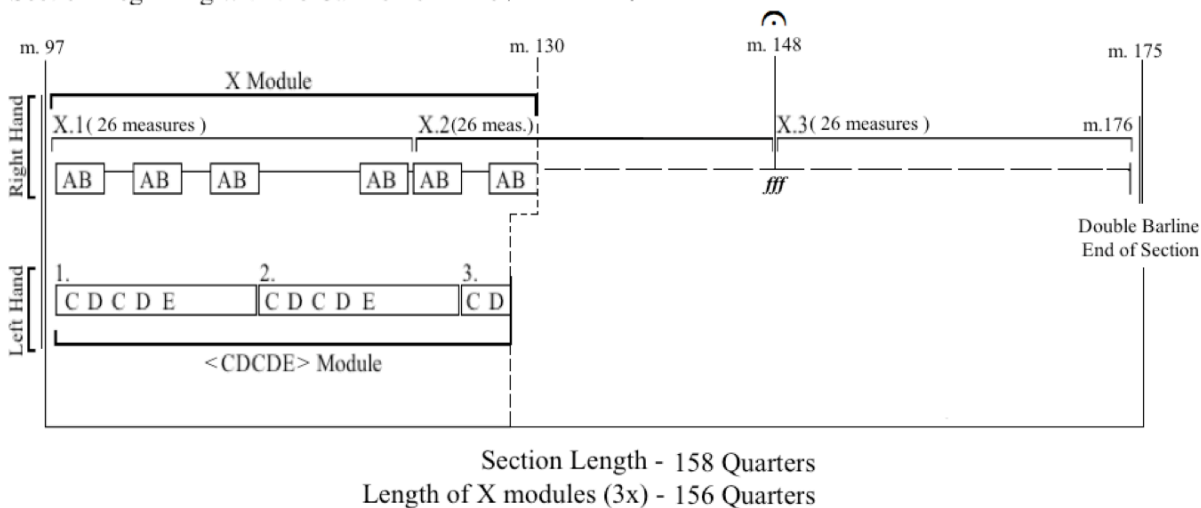
Section Beginning with the Carillon of Time (*mm. 97 - 175*)

Unlike the first movement, this *talea* is not overlaid by any *color*, per se. Instead, the pitch content of the carillon is composed of alternating tritone dyads, with two pairs per hand. The right hand comprises the collection [2, 5, 8, 11], while the left hand comprises [1, 4, 7, 10]. A reduction of the carillon pitches yields the following symmetrical collection, consistent with Messiaen's second mode (second transposition) when juxtaposed:

Figure 4.2. Pitch reduction of the carillon ostinato, mm. 97–130.

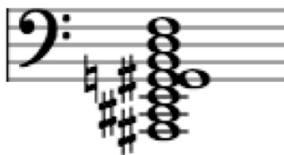

Intervals between notes [ 3, 3, 3, 1, 3, 3, 3 ]  
(Ascending)

Recall the chords that constituted the *color* in “Amen de la Création” (figure 2.1). Each chord is paired with its inversion, resulting in mirror symmetry between both hands. In a similar fashion, pairing the right and left hand chords yields the highly symmetrical collection previously shown. Although it may seem trivial, both hands contain a chord that is the literal inversion of the other. Once again, a symmetrical chord is created through the amalgamation of two inversionally related chordal “bodies.”

Movement IV concludes with a coda section in mm. 176–185. Siglind Bruhn highlights Messiaen’s pervasive use of three in both horizontal and vertical structures throughout in the coda. The three phrases of the coda comprise three three-beat measures each. Vertically, three timbral layers (a pedal on G, mid-range thematic material, and chiming chords in the upper register) unfold throughout the coda, and eventually constitute the final chord. In the middle phrase, Messiaen juxtaposes three motions—a descending motion in piano 1, and ascending motion in the left hand of piano 2, and the aforementioned pedal on G.<sup>58</sup>

### **Symmetry in orbit**

The second movement of the piece is centered on a single theme, dubbed “the theme of the dance of the planets” by Messiaen.<sup>59</sup> The composer identifies several components that make up the theme: a head motive, labeled “X fragment” in the *Traité*, which is the ordered

---

<sup>58</sup> Siglind Bruhn, *Messiaen’s Contemplations of Covenant and Incarnation: Musical symbols of faith in the two great piano cycles of the 1940s* (Hillsdale: Pendragon Press, 2007), 122.

<sup>59</sup> “Thème de la danse des planètes.”

pitch-class set  $\langle 0, 11, 10, 7, 4, 4 \rangle$  and the “Y fragment,” which comprises three smaller sets: two dyads, and one three-pitch set.<sup>60</sup>

Figure 5.1. Motivic fragments that constitute the “theme of the dance of the planets.”

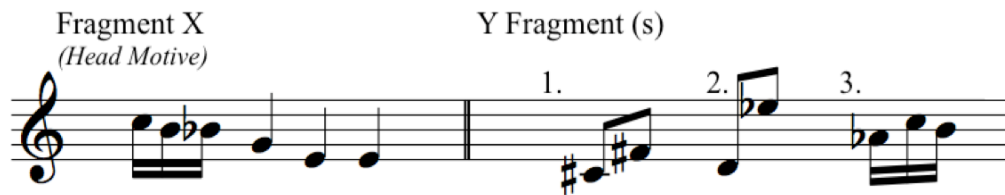

The latter fragments, while an indispensable part of the overall theme, are not developed and prolonged in the three subsequent development sections. The head motive, however, is manipulated extensively through each development. Messiaen describes the form of the movement as:

1. Theme of the Planets — Complete phrase, monophonic, in E minor.
2. First Development — Development of the head of the theme (the 5 notes), through change in register and rhythmic variation.
3. Second Development — The head of the theme (the 5 notes) in contrasting registers, and elimination ([the theme is] reduced to 3 notes).
4. Third Development — In piano 1: the head of the theme (the 5 notes) fixed to a rhythmic pedal. In piano 2: the head of the theme, in rhythmic variation and changes in register. Both superimposed — the dominant of E.
5. Return to the (theme of) the dance of the planets: the complete phrase in piano 2, and harmonies in piano 1.<sup>61</sup>

<sup>60</sup> Olivier Messiaen, *Traité de Rythme, de Couleur, et d'Ornithologie*, III (Paris: Alphonse Leduc, 1996), 235.

The opening section of the five-part movement, while it functions as an exposition, also manipulates the order of the fragments in the service of generating new phrases. After two nearly identical phrases, articulated by breath marks in mm. 1–19,<sup>62</sup> Messiaen generates a contrasting phrase from the same material (fragments) as before. The first contrasting phrase begins at m. 19 with a retrograde of the first five pitches of the head motive.

Figure 5.2. Fragments in order, constituting a phrase (“phrase C” in figure 5.3), mm. 19–23.

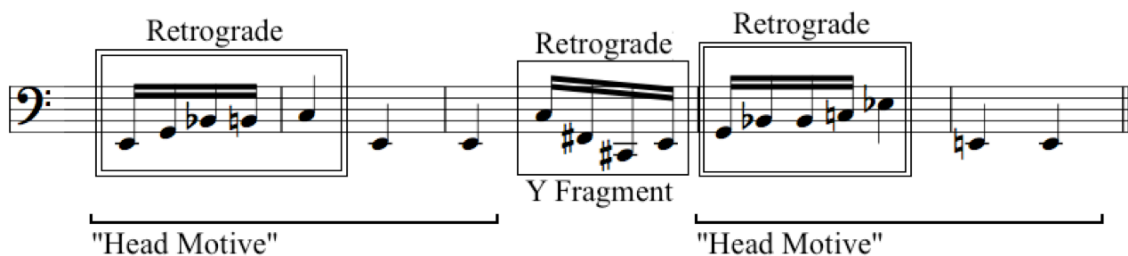

possibility that the retrogrades / inversions of a statement are merely rotations of a single entity along an otherwise set “orbit.”<sup>64</sup>

The five phrases that constitute the exposition are arranged in a pseudo-symmetric fashion, with the final phrase structure (coda) offsetting a literal symmetry.<sup>65</sup> While the aforementioned fragments are developed through permutation and transposition, the underlying structure of each phrase remains fairly consistent. Figure 5.3 outlines the basic structure of each phrase, as well as the clearly proportional design of the exposition as a whole. The overall structure of the exposition suggests symmetry around the inner, contrasting phrase. Tonally, Messiaen indicates that the movement is based on a tonic “E,” and that each phrase either ends on the dominant or the tonic.<sup>66</sup> Informed by cadences alone, the phrases exhibit the symmetry: tonic, tonic, dominant, tonic, tonic. While these traits alone don’t produce literal symmetry, they do suggest that the third phrase is a division between two otherwise similar halves.

---

<sup>64</sup> Messiaen describes his interest in the “music of spheres” in Almut Rößler, *Contributions to the Spiritual World of Olivier Messiaen* (Duisburg: Gilles & Francke, 1986), 113. Stephen Schloesser analyzes Messiaen’s use of the “music of spheres” in the chapter “Amen of the Stars, of the Planet with the Ring” in *Visions of Amen: The Early Life and Music of Olivier Messiaen* (Grand Rapids: William B. Eerdmans Publishing, 2014), 309–337.

<sup>65</sup> This is remarkably similar to the arrangement of thematic sections in the final movement of the work.

<sup>66</sup> Olivier Messiaen, *Traité de Rythme, de Couleur, et d’Ornithologie*, III (Paris: Alphonse Leduc, 1996), 233–243.

Figure 5.3. “Amen des Étoiles, de la Planète à l’Anneau,” symmetrical phrase design.

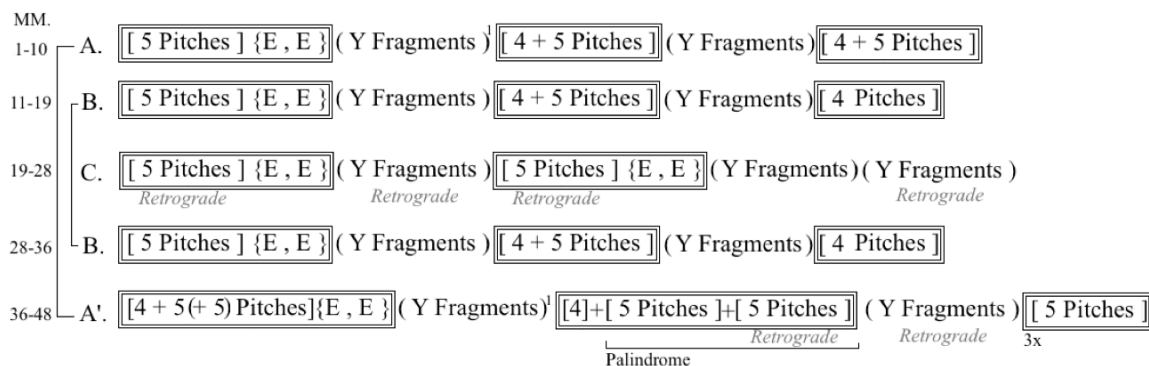

Boxed pitches belong to the head motive, set [0, 11, 10, 7, 4]. The number of pitches moving in similar motion is indicated as either 4 (the first four pitches of the set) or 5 (the whole set, including pc 4). The head motive, as Messiaen describes it in the *Traité*, traditionally concludes with a two-fold statement of pc 4 in quarter notes, written as {E, E} in figure 5.3.

The Y fragments are arranged more liberally throughout the exposition, but some clear parallels exist between ordering of Y fragments in the opening and closing phrase, which are identical. This distinction further suggests that the opening and closing phrase are related, and that an underlying symmetry clearly exists. In recapitulation of the prior material, the coda comprises the five pitches of the head motive in both prime and retrograde forms followed by all three Y fragments, in order, but with each fragment retrograded.<sup>67</sup> The exposition concludes with a three-fold statement of the five-pitch set as it descends through three registers.

<sup>67</sup> In figure 4.2, taken from Messiaen’s own analysis, the Y fragments are presented in the order: 1, 2, 3. Each fragment within that sequence, however, occurs in retrograde.

### The composition's original center, "Amen de l'Agonie de Jésus"

Perhaps in an effort to retroactively place emphasis on the three-octave descent that brought the second movement to a close, the third movement begins with a similar three-octave descent, this time with two different dyads: C–E $\flat$  in piano 1, and D–F $\sharp$  in piano 2. While the gesture continually articulates a return of the opening phrase, Messiaen does not ascribe to the gesture any motivic significance in the *Traité*. In fact, Messiaen only mentions the following three themes of the movement: the Father's curse on the sins of the world, Jesus's cry, and the tears of Jesus in his agony.<sup>68</sup> Perhaps the descending gesture explicitly serves as an articulation, recalling the opening phrase rather than contributing to the overall narrative. In any case, the three-part nature of the gesture should be taken into consideration. Messiaen's indication of three unique themes proves to be, not surprisingly, quite significant in light of earlier observations. If the influence of the Trinity underlies these themes, then it should be expected that the themes themselves exhibit either some sort of symmetrical construction or three-part design. Indeed they do, and to a remarkable degree.

The first theme to appear is referred to as the theme of the "anguish of the Father" in Messiaen's own analysis in the *Traité*. Rather than presenting the theme as it occurs in the score, Messiaen simply claims it follows the progression outlined in figure 6.1, label "A." The theme first occurs at the very end of the strophe, in mm. 10–11 (figure 6.1, label "B"), as two reverse-related ostinati in the right and left hands. The juxtaposition of both hands generates the highly symmetrical configuration illustrated in 6.1, label "A."

---

<sup>68</sup> "La malediction du Père sur le péché du monde," in Olivier Messiaen, *Traité de Rythme, de Couleur, et d'Ornithologie*, III (Paris: Alphonse Leduc, 1996), 244. "Un cri," in Oliver Messiaen, "Note de l'Auteur," *Visions de l'Amen* (Paris: Durand, 1943), n.pag. "Les larmes de Jésus dans son Agonie," in the *Traité*, 246.

Figure 6.1. Symmetry in the theme titled, “the curse of the Father.”

A.

2 4 9  
1 3 1  
9 4 2

B.

Messiaen would have been fully aware of the interlocking parts, not only in principle as he wrote the piece, but also in the physical movements involved in the performance of each gesture: the left hand contracts inward while the right hand expands outward, both gestures symmetrical around dyads [1, 3] and [9, 10]. This physical movement, of contraction and expansion, foreshadows the third theme to occur in the movement: the tears of Jesus. The aforementioned gestures that constitute the “curse” theme are also present in the “tears” theme. It would appear as though the two distinct, self-sufficient themes are connected in some way; the motion, manifested as a literal expansion and contraction of the fingers on the piano, connects both themes under a common gesture not explicitly evident in the printed music.

The “tears” theme, played by an unaccompanied piano 2 in mm. 32–46, comprises two transpositions of a common gesture (figure 6.2) that alternate in groups of three. Three statements of the theme in its original transposition (figure 6.2, label “A”) are followed by three statements of the theme after it is transposed down a half step (figure 6.2, label “B”). After two repetitions of three statements in each transposition, Messiaen then varies the number of consecutive statements of a transposition (presumably as it conforms to the surrounding, developing theme). He does, however, bring the theme to a close with a three-fold statement of the final transposition, followed by a fermata in m. 46.

Figure 6.2. Gestural symmetry in the theme titled “the tears of Jesus in his agony.”

Figure 6.2 illustrates the gestural symmetry in the theme. Part A shows two musical staves. The first staff, labeled '1.', shows a three-note dyad in G minor (G4, Bb4, D5) with a '-1' above and '+1' below. The second staff, labeled '2.', shows the same dyad transposed down a half step to F minor (F4, Ab4, A4) with a '-1' above and '+1' below. A vertical line labeled 'T11' connects the two staves. Part B.1 shows two piano keyboard diagrams. Diagram 1 shows finger positions for the first staff: Finger Position 1 (solid circle) on G4 and Finger Position 2 (open circle) on Bb4. Diagram 2 shows finger positions for the second staff: Finger Position 2 (open circle) on F4 and Finger Position 1 (solid circle) on Ab4. Arrows indicate the movement of fingers between positions.

Beneath this ostinato of alternating dyads and its transposition are three-note ostinatos:  $\langle 7, 5, 4 \rangle$  below the original transposition, and  $\langle 5, 4, 3 \rangle$  below its  $T_{11}$  transposition. Much like the perceived tears of Christ, these ostinatos descend by step.

The coda, or epode, briefly paraphrases the creation theme. “Why (a return to) the creation theme?” Messiaen asks rhetorically, “because the sufferings of Christ give grace and create mankind anew.”<sup>69</sup> In terms of the overall narrative, this paraphrase at the conclusion of the third movement foreshadows the return of the carillon of light in the fourth movement, while also placing emphasis on the overall formal symmetry around the fourth movement, as the theme also briefly returns in the fifth movement. An additional paraphrase of the creation theme at the very end of the third movement provides a link between the first, third, and final movement (which had been the fifth movement in Messiaen’s earlier design). The injection of the two newest movements, the fourth and fifth, offsets this symmetrical connection, replacing it with symmetry around the fourth movement now implied by the presence of the carillon and its corresponding *talea* and *color*.

## Conclusion

While the nature of symmetry exhibited by the inner movements changes considerably depending on analytic criteria (especially if one of those criterion prioritizes thematic content, subject matter, or musical texture and form), similar musical structures, often influenced by the number three and five, occur in the first, fourth and final movements. Between these “pillars” of symmetry, Messiaen’s integration of balanced,

---

<sup>69</sup> “Porquoi le Création? Parce que les souffrances du Christ donnent le grâce et créent l’homme nouveau.” Olivier Messiaen, *Traité de Rythme, de Couleur, et d’Orinithologie*, III (Paris: Alphonse Leduc, 1996), 248. Context added.

pseudo-symmetrical structures throughout the composition affirms the notion that both symmetry and numerology play an integral role in the large-scale, often less apparent structures of *Visions de l'Amen*. The composer often employs the numbers three, five and seven into his formal plans; this, coupled with both the highly symmetrical nature of these forms, and the narrative as a whole, suggests more than just an affinity for balance.

Symmetry, both vertical and horizontal, and the symbolic numerical values discussed are almost always concurrent—essentially transfigurations of a single structural entity. Both aspects are unified under a common theme: God, the divine, and the eternity. While the written narrative can only supply limited fodder for a theological interpretation of Messiaen's musical writing, the application of the aforementioned techniques, devices and forms—perceptible or imperceptible—breathe a certain vitality into the composition that brings an unwritten narrative “to life.” In the introduction to his book, *The Reinvention of Religious Music: Olivier Messiaen's Breakthrough Toward the Beyond*, Sander van Maas poses the question:

The notion of the sublime, which as such seems to be such an apt concept for the music of Messiaen, entails the question of the boundary between truth and technique, between revelation and construction; and between religion, philosophy, and art. How to decide on the “overwhelming” of *La Transfiguration* or *Saint François d'Assise* as the event of truth, on the one hand, but on the other as a sublime truth *effect*, the apparent event of truth in the manner of *as if*?<sup>70</sup>

Such an effect is constantly suffused with symmetry, expressed in values of three, five, and seven. Messiaen did not consider himself a mystic—his musical output was not directly sent from God, only to be written through the composer's hands. Instead, Messiaen's sincere

---

<sup>70</sup> Sander van Maas, *The Reinvention of Religious Music: Olivier Messiaen's Breakthrough Toward the Beyond* (New York: Fordham University Press, 2009), 2. Emphasis in original, quotations added for context.

adoration of the divine informed the composer's aesthetic goals and the compositional devices required to express them. He sought to represent the divine in two ways: through symbolic description, and through imitation of the divine "effect." In *Visions de l'Amen*, Messiaen does both: the composer's prevalent use of numerical, gestural and symmetrical symbols constitute the former representation while Messiaen's partitioning and calculated control of large-scale, often monolithic, expanses of time emulates the influence of God beneath the threshold of clear perceptibility, resulting in pure effect. The contrast between both pianos reveals a juxtaposition of qualitative and quantitative treatments of time, a type of duality inherent in the aforementioned effect. Messiaen's technique actively embodies aspects of the divine where words would otherwise fail—music brought to life by his portrayal of God, by means of a *musique vivante*.

### Chapter III:

The Homogeneity of Opposition in Gérard Grisey's *Talea*

The word “talea” has two separate meanings: in Latin, the term describes the act of “cutting,” while in musicological scholarship it is also used interchangeably with the word “isorhythm” as a term for the repeated rhythmic structures prevalent in medieval music. In Gérard Grisey’s composition *Talea*, both definitions of the word play an active role in defining the piece. According to the composer, the composition is based on an initial idea that is “cut” and developed over the course of the work.<sup>1</sup> The sonorous material of the work, a sequence of three-stage cycles, is suspended in a constant state of entropy; the proportions and characteristics of its internal components change according to several gradual processes.<sup>2</sup> Each cycle, exemplary of the definition of “talea” that pertains to rhythm, is composed of two contrasting materials and one neutral material that are gradually diffused and merged over the course of the movement. This amalgamation of opposing materials reveals the interrelatedness between all facets of the sound object, and is the ultimate goal reached through a constant cutting and repositioning of materials over time.

Gérard Grisey (1946–98) was one of the eminent composers of the French “spectral school,” a group of composers who used the acoustic properties of a sound (informed largely by spectral analysis, which reveals the fundamental and partial tones of a given sound) as a basis for the organic or artificial manipulation of a timbre in the

---

<sup>1</sup> In the preface of Gérard Grisey, *Talea* (Milan, Italy: Ricordi, 2009), n.pag.

<sup>2</sup> This multi-faceted musical subject, the cycle, exemplifies an underlying concern of Grisey and Dufourt’s compositional procedure, described by Viviana Moscovich as the construction of “sound-entities that are formed, transformed and transmuted. These sound-entities thus become the nucleus from which the piece develops over time.” Viviana Moscovich, “French Spectral Music: An Introduction,” *Tempo*, no. 200 (April 1997): 27.

service of harmonic development.<sup>3</sup> The use of spectral analysis was thus a means to an end—the purpose was not to replicate the sounds, but rather to manipulate their components in order to produce new sounds. In his article “Spectralism,” Jonathan Harvey distills the harmonic basis of spectral music down to its very essence; Harvey proclaims: “Here, for the first time, there is no distinction between harmony and timbre. Harmony is timbre; timbre is harmony.”<sup>4</sup>

Tristan Murail commented on the matter, suggesting that spectral music isn’t a set of materials and techniques but rather an attitude toward composition as a whole.<sup>5</sup> Murail’s first piece to exemplify the spectral approach without placing emphasis on the spectrum, *Mémoire-érosion* (1976), is based on the feedback mechanism of a tape machine; the use of harmonic spectra is incidental, as Murail did not consciously extract his pitch content from an extended spectrum (although he does imitate natural timbres by often using the lower partials of a given sound). While harmonic spectra seem to be indispensable aesthetic components of spectral music, their limited role in Murail’s earlier music draws attention to the idea of process as a principal underlying syntactic element, which is particularly evident in Grisey’s work.<sup>6</sup>

---

<sup>3</sup> While a sound’s spectrum offers a natural harmonic model, the fundamental structure of a spectrum may be proportionally altered in an artificial fashion. In Grisey’s composition *Vortex Temporum*, multiple artificial spectra are generated from a single fundamental tone, B♭. Grisey manufactures two theoretical spectra—one expanded, one compressed, which are slightly larger or smaller than the natural spectrum—by applying a mathematical formula to the fundamental frequency. To this end, while the spectrum is used in a completely unnatural fashion, the general concept of “spectrum” still provides the basis for the composition. Robert Hasagawa, “Gérard Grisey and the ‘Nature’ of Harmony,” *Music Analysis* 28, nos. 2–3 (2009): 352–354.

<sup>4</sup> Jonathan Harvey, “Spectralism,” *Contemporary Music Review* 19, no. 3 (2000): 12.

<sup>5</sup> Joshua Fineberg, “Spectral Music,” *Contemporary Music Review* 19, no. 2 (2000): 2.

<sup>6</sup> Tristan Murail, “After-thoughts,” *Contemporary Music Review* 19, no. 3 (2000): 7.

In his dissertation, “Pushing the Envelope: The Art and Science in the Music of Gérard Grisey,” Christopher Arrell asserts that spectral thought is founded on the principle that sound is a macrocosm within a microcosm; from timbre to form, the physical structure of acoustic sound offers multiple resolutions to compositional concerns.<sup>7</sup> The seemingly infinite physical properties of a sound, such as the interaction and periodicity between overtones or the amplitude of waves, bring to light a natural syntax that may project itself onto the large-scale form of an entire movement. The spectrum, as a point of reference, offers a rich basis for harmonic and timbral manipulation; altering higher partials will fine-tune degrees of harmonicity, while altering tones closer to the fundamental results in more rapid harmonic changes. Movement between both ends of the spectrum (between fundamental and higher partials) directly affects the presence—and, thus, recognition—of the characteristic fundamental tone. A departure from, and return to, the fundamental offers tremendous form-articulating potential, which is realized by Grisey in the first section of *Talea*. Unlike the tonal system, which embodies a natural hierarchy of components (tonic, dominant, subdominant) that can only be understood temporally as a sequence of events with predictable outcomes, the “hierarchy of spectra,” as Jonathan Harvey puts it, can exist instantaneously as well as temporally.<sup>8</sup> *Talea* begins with an inharmonic spectrum that gradually progresses towards harmonicity; with no degree of expectation or knowledge of the underlying tone, the process must be perceived in its entirety.

---

<sup>7</sup> Christopher Arrell, “Pushing the Envelope: Art and Science in the Music of Gérard Grisey, Part II” (D.M.A. diss., Cornell University, 2002), 18.

<sup>8</sup> Jonathan Harvey, “Spectralism,” *Contemporary Music Review* 19, no. 3 (2000): 12.

In his article, “Did you say spectral?” Grisey elaborates on the perception of time in spectral music, asserting that time itself is integrated into the sound object and is an objective property of the materials at hand. Grisey states:

Strengthened by an ecology of sounds, spectral music no longer integrates time as an external element imposed upon a sonic material considered as being “outside-time,” but instead treats it as a constituent element of sound itself. This music forces itself to make time palpable in the “impersonal” form of durations; apparently far removed from spoken language, but doubtlessly close to other biological rhythms which we have yet to discover. Finally, it is sounds and their own materials which generate, through projections or inductions, new musical forms.<sup>9</sup>

Grisey continues to outline several considerations with regard to form that arise from the integration of time into the sound object. Notable considerations include the “interplay between fusion and continuity, on one side, and diffraction and discontinuity, on the other,” and, “superposing and placing in and out of phase contradictory, partial, or implied processes.”<sup>10</sup>

While the term “spectral” is directly drawn from the terms “spectra” and “spectrogram,” the term will be used here in order to describe a general way of thinking about musical dichotomies as two forces capable of assimilation by some process.<sup>11</sup> This attitude is particularly evident in Grisey’s work, where two opposing ideas (loud / soft, high partials / fundamental tone, short durations / long durations, periodicity /

---

<sup>9</sup> Gérard Grisey, “Did you say spectral?” *Contemporary Music Review* 19, no. 3 (2000): 2.

<sup>10</sup> *Ibid.*, 3.

<sup>11</sup> As a general trend in spectral music, processes span long periods of time in the service of articulating large-scale formal divisions, such as a section or an entire movement. This consideration stems from one of Murail’s principal assertions regarding the spectral mindset: a spectral work must be conceived globally, and not as a product of sequential or cellular thinking. Viviana Moscovich, “French Spectral Music: An Introduction,” *Tempo*, no. 200 (April 1997): 22.

aperiodicity, harmonicity / inharmonicity, etc.) are either slowly brought together or pulled apart throughout the course of a movement or section. The integration or separation of such contrasting ideas is subject to an underlying process of linear transformation; again, the process itself unfolds according to a regular gradation between both ends. Grisey comments on the matter, explaining: “the spectral method and, more important, the processes of transformation that I use allows, in principle, for the integration of all sounds (timbres).”<sup>12</sup>

In this regard, there is no clearly defined boundary between the two opposing forces—they are merely two ends of a scale; between them is an infinitely gradated field of possibilities and combinations. In his article “Gérard Grisey and the Foliation of Time,” amidst discussions of the history, aesthetics and techniques of Grisey’s music, Pierre Albert Castanet outlines several important dichotomies in the composer’s music that are particularly relevant to both *Partiels* (1975) and *Talea* (1986).<sup>13</sup>

---

<sup>12</sup> “Le méthode spectrale et, plus encore, les processus de transformation que j’utilise permettent d’intégrer en principe tous les sons.” Gérard Grisey, quoted in Danielle Cohen-Levinas, “Combinatoire Sérielle, Maïeutique Spectrale: Une généalogie du matériau,” *Musurgia* 3, no. 3 (1996): 82.

<sup>13</sup> P. A. Castanet, “Gérard Grisey and the Foliation of Time,” *Contemporary Music Review* 19, no. 3 (2000): 33–34.

Figure 1. P.A. Castanet's table of opposing forces in the music of Grisey.

|  |                                       |                                    |                          |
|--|---------------------------------------|------------------------------------|--------------------------|
| <i>dynamic pole</i>  | <i>durations</i>                      | <i>phasing</i>                     | <i>time</i>              |
| ppp<br>FFF   | strict notation<br>repetition ad-lib. | periodic<br>aperiodic              | striated<br>non-pulsated |
| <i>kinetic, spatio-temporal activity</i>                   |                                       | <i>rhythm</i>                      | <i>agogic</i>            |
| passive (fermata)<br>active                                | sometimes free                        | sometimes free<br>poly-tempi       | release<br>tension       |
| <i>sonic genesis</i>                                       |                                       | <i>aesthetic</i>                   |                          |
| biomorph (natural model)<br>technomorph (electronic model) |                                       | organic nature<br>artificial noise |                          |

Reprinted from P.A. Castanet, "Gérard Grisey and the Foliation of Time," *Contemporary Music Review* 19, no. 3 (2000): 34.

The musical object of the first section is the cycle. Distinct materials based on the qualities outlined in the aforementioned chart, when arranged in a fixed order, constitute a full cycle. Two of the materials are opposing forces—one is defined by loud dynamics, short durations and tension; the other is built on long durations and soft dynamics, characterized as a release. These will be referred to as A material and B material, respectively.<sup>14</sup> Arrell describes the physics of a sound wave in particularly relevant terms: "pressure causes molecules to compress, and a rarefaction occurs as the medium overcompensates in an attempt to return to its natural state."<sup>15</sup> In *Talea*, fast, loud bursts

<sup>14</sup> In figure 1, the B material corresponds to the adjective on the top of each pair, while the bottom corresponds to the A material.

<sup>15</sup> Christopher Arrell, "Pushing the Envelope: Art and Science in the Music of Gérard Grisey, Part II" (D.M.A. diss., Cornell University, 2002), 9.

of activity start each cycle and are followed by drawn-out, faint material in reaction to the initial disturbance. The two forces balance each other, and the consequence is silence; an archetype, comprising three stages, commonly referred to as the spectral envelope.<sup>16</sup> The complete cycle is thus a metaphor, where silence is interrupted—or cut—by tense bursts of activity. B material is the resultant transition between the interruption and silence—a type of reverberation, so to speak. The opposing qualities detailed in figure 1 are particularly relevant to *Talea*, as the A and B materials fit the criteria outlined in the table. Even the final category (sonic genesis / aesthetic) is applicable to *Talea*. While aesthetic descriptions may seem purely speculative, the subtitle of the piece, “The Machine and the Wild Weeds,”<sup>17</sup> alludes to the possibility of a natural / artificial polarity that is explored in the musical narrative and, thus, the material. Grisey specifies that despite the polarity that exists between the aforementioned dichotomies, they are merely two sides of the same coin. He asserts:

In *Talea*, I tackle two aspects of musical discourse from which my research on instrumental synthesis, on microphonics and on contiguous transformations had estranged me, that is speed and contrast. *Talea* consists of two parts linked together without interruption, which express two aspects or, more precisely, two auditory angles of a single phenomenon.<sup>18</sup>

From the microcosm to the macrocosm, Grisey blurs the lines between opposing elements and exploits the space between them. This potential for gradual change and development provides the basis for syntax in the first section of *Talea*.

---

<sup>16</sup> Ibid., 19.

<sup>17</sup> In lieu of the translation offered in the score, I have chosen a more suitable translation: “wild” rather than “rank.” The original title in French is “les herbes folles.”

<sup>18</sup> Gérard Grisey, *Talea* (Milan, Italy: Ricordi, 2009), preface, n.pag.

Bearing in mind Castanet's table of contrasting elements, I propose a similar basic model for the first section of *Talea*, which will constitute the focus of this analysis. Five fundamental processes are responsible for driving the polyphony of cycles toward its ultimate goal: a neutralization of several dichotomies as all voices realign on a unified, homophonic ostinato comprising the lowest partials of the harmonic series. The two opposing ends of each process are detailed in figure 2, with the category of each process presented on the left. Each process will be discussed thoroughly in the following analysis.

Figure 2. The dichotomies of *Talea*.

| Linear Processes / Dichotomies |                       |                     |
|--------------------------------|-----------------------|---------------------|
| Category                       | Start                 | Finish              |
| • <b>Materials</b>             | Separated             | Integrated          |
| • <b>Time</b>                  | Dilated, Unmeasurable | Regular, Measurable |
| • <b>Phrasing</b>              | Aperiodicity          | Periodicity         |
| • <b>Contour</b>               | Unidirectional        | Multidirectional    |
| • <b>Pitch Content</b>         | Higher partials       | Lowest Partial      |

### Structure, Form

The basic structure of *Talea* comprises two uninterrupted sections, which are divided at rehearsal no. 20. The first section is largely polyphonic—several voices, gradually pulled from a single homophonic source, introduce a distinct cycle, or “talea,” of rhythmic activity paired with a specific harmonic color that is brought in and out of phase with the cycles contained in other voices. Upon realignment of the polyphonic voices at rehearsal no. 17, there is a short transition section in which all voices participate

in a wave-like ostinato as the pitch content of the homophony nears its intended goal—an unmistakable representation of the harmonic series from the fundamental to its 32<sup>nd</sup> partial. The second section is predominantly homophonic, highlighting only one “cycle” at a time. In this section, the tripartite structure of the cycle is no longer applicable; the cycles that occur in this section are signaled by a rapid tremolo in the piano, followed by the other instruments playing recycled, developed material from the first section. Grisey describes the second section as being “pierced by more or less irrational emergences, kinds of recollections from the first part, which gradually assume the color of the new context until they become unrecognizable.”<sup>19</sup> The piano plays an important role throughout the composition by maintaining the original voice throughout the first section, as well as signaling new cycles in the second section. This analysis will place additional emphasis on the piano as the “control” instrument, since it continues to project the original voice of the first section, confined to tempered pitch material, even after the other instruments diverge from it.

Each of the five instruments in Section I carry a sequence of cycles that continuously repeats unless otherwise altered. The word “sequence” is used here to describe an ordered process of progressive diminution; each subsequent cycle in the series is a quarter note shorter in duration than the one previous. As a general tendency, this pattern remains constant in the first section. In several instances, however, Grisey interferes with the otherwise mechanical process by pulling voices out of phase with one another in the service of establishing polyphony. This linear process, with some outside

---

<sup>19</sup> Located in the preface of Gérard Grisey, *Talea* (Milan, Italy: Ricordi, 2009), n.pag.

interference from Grisey, allows the voices to converge slowly into a single homophonic cycle before transitioning into the second section.<sup>20</sup>

Each cycle, with the exception of the first, is generally constructed in the following fixed sequence: A material, B material, silence. Much like the overall length of the cycles, the materials within each cycle are also subjected to linear processes of either growth or reduction. The A material grows steadily throughout Section I while the proportions of B material and silence are gradually reduced (figure 3).

Figure 3. Proportions of distinct materials in each cycle in the piano.

A. Length of piano cycles 1–16, with ratio of constituent materials.

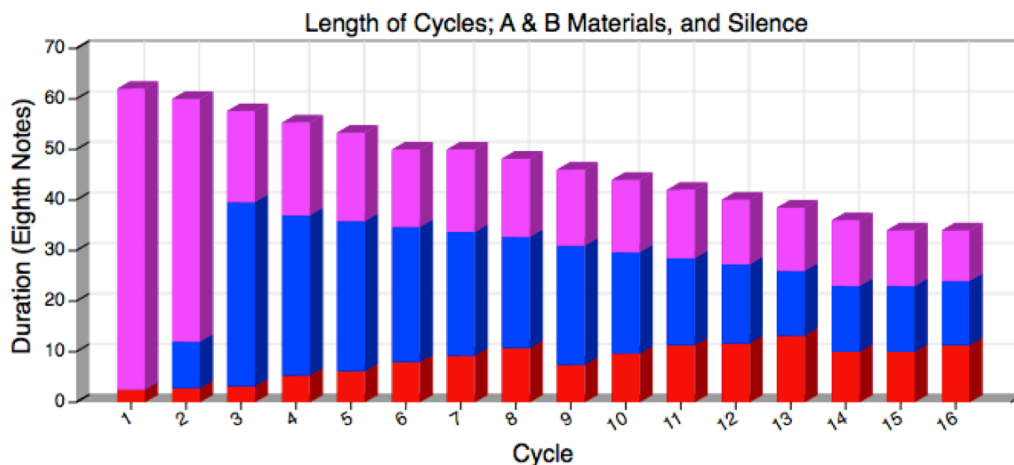

Cycle components: A material (bottom), B material (middle), silence (top).

<sup>20</sup> The frequent interference with an underlying process in the music is evident in Grisey's later work. Murail made note of this trend, stating: "In *Gondwana* (1980) for orchestra, which is considered a typical piece for its period, there is continuity, but there are also ruptures and many other types of transition..." Murail goes on to suggest that this interference, with regards to the spectral ideology, should be "viewed more as a development than a renunciation." Tristan Murail, "After-thoughts," *Contemporary Music Review* 19, no. 3 (2000): 7, quoted in Kari Besharse, "The Role of Texture in French Spectral Music" (D.M.A. diss., University of Illinois at Urbana-Champaign, 2009), 20.



piece revolves around an ideal path, from which we slowly stray up to a certain distance; once having tacked, we may then return.”<sup>22</sup> While the “ideal path” in *Dérives* is articulated by motion around a principal harmonic timbre, the same tenet guides the evolution of polyphonic voices as they reproach the ideal path suggested by the piano. The gradual convergence of several processes at the end of the first section of *Talea* brings to mind the first section of Grisey’s *Périodes* (1974), in which the principal design features the convergence of several processes, but without the interference and licenses seen in the polyphonic writing of *Talea*.

Figure 4. Sketch of the first section of *Périodes*.

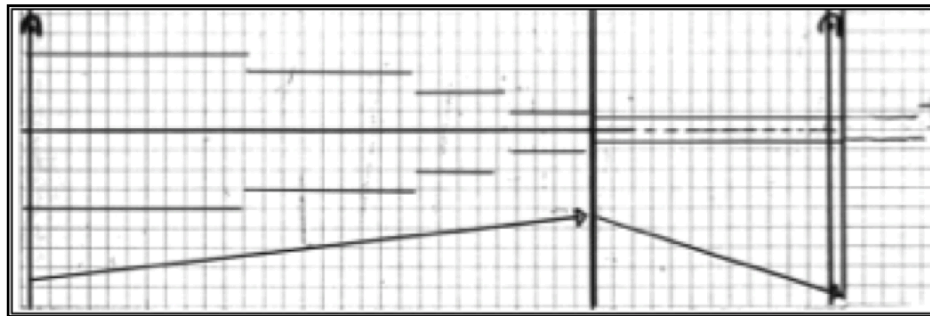

Sketch located in the Gérard Grisey Collection, Paul Sacher Foundation, Basel, Switzerland; reprinted from François Féron, “The Emergence of Spectra in Grisey’s Compositional Process: From *Dérives* (1973–74) to *Les espaces acoustiques* (1974–85),” *Contemporary Music Review* 30, no. 5 (2001): 349.

---

<sup>22</sup> Gérard Grisey, *Écrits ou l’invention de la musique spectrale*, eds. Guy Lelong and Anne-Marie Réby (Paris: MF Éditions, 2008), 129, quoted in François Féron, “The Emergence of Spectra in Grisey’s Compositional Process: From *Dérives* (1973–74) to *Les espaces acoustiques* (1974–85),” *Contemporary Music Review* 30, no. 5 (2001): 349.

Despite the disruption caused by the parsing out of the homophonic voice into many separate voices, the linear unraveling of cycles divided between each of the five polyphonic voices is clearly directed toward the forthcoming ostinato. The piano-centric implications of this procedure are reflected, or at the very least enforced, by the physical arrangement of instruments in the ensemble, as shown in figure 5. Since the piano carries the original voice throughout the first section of the work, its importance here is that of a placemaker—the instrument itself receives no more emphasis than any other, but is the sole instrument in the ensemble to continue the original voice of the work throughout the entire section. Presented in figure 6 is a proportional representation of the polyphonic arrangement of cycles in the first section, with events weighed against the original “voice” (indicated by rehearsal numbers).

Figure 5. The arrangement of instruments on stage, reprinted from the performance notes.

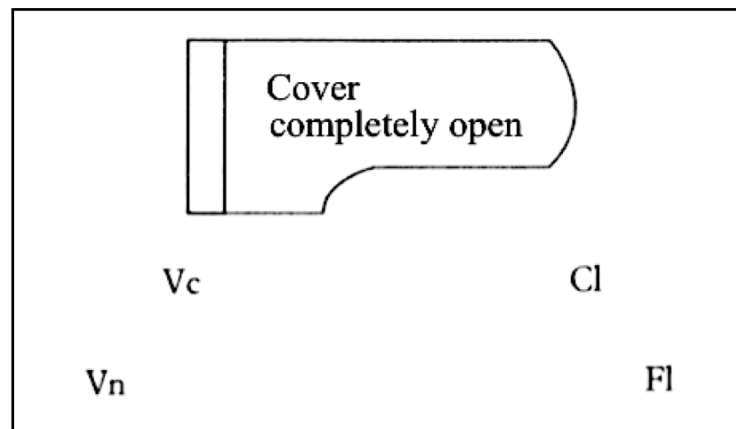
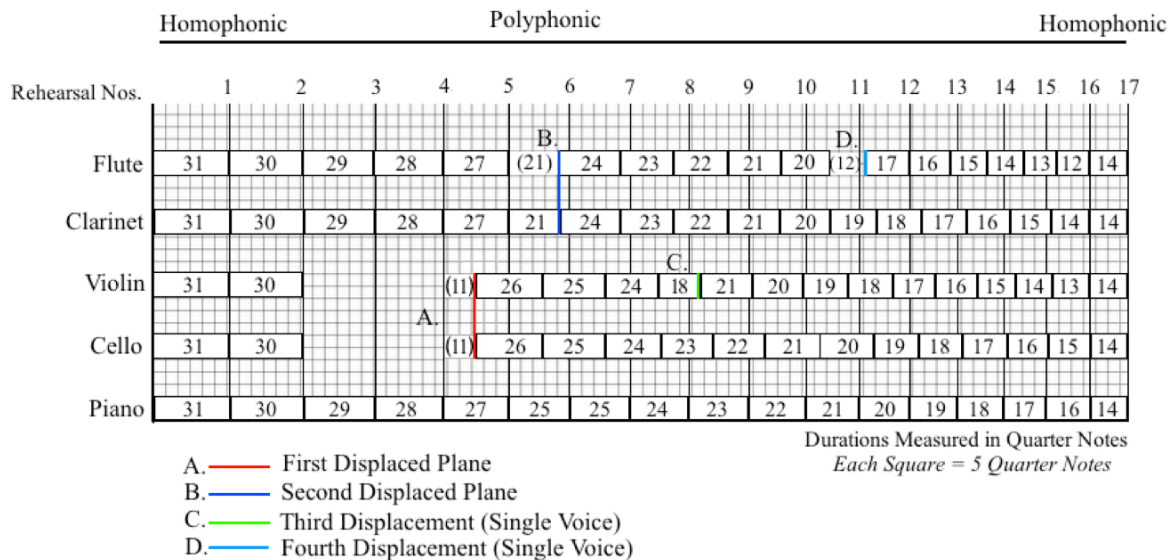

Figure 6. Proportional layout of cycles 1–17 against original voice (piano), Section I.



While the processes of *Talea* are predominantly linear, figures 6 and 8 show the degree to which Grisey interferes with and redistributes portions of the original homophonic voice, composed of constantly decreasing cycles, into five independent polyphonic voices. By the end of the 16<sup>th</sup> cycle (articulated by the tutti at rehearsal no. 16) each voice has moved into back into phase. Unless altered, the duration of each successive cycle of activity is systematically reduced by a quarter note, and the process governs itself. While all instruments participate in the first two cycles of the primary voice, Grisey removes a pair of instruments (the cello and the violin) and assigns them to the first polyphonic voice (figure 6, label “A,” and figure 8).<sup>23</sup> He then goes on to displace the flute and clarinet in similar fashion (figure 6, label “B,” and figure 8). This technique is referenced earlier in figure 6 as the “displacement of a plane,” which simply

<sup>23</sup> Evidence suggests the first polyphonic voice carried by this pair of instruments begins shortly after rehearsal no. 3, roughly 27 quarter notes before a prominent articulation that denotes the beginning of a cycle (figure 6 label “A”). The two interpretations will be rectified in the forthcoming analysis.

refers to the process of moving an entire group of homophonic voices as a single unit, which then function as a new polyphonic voice while still adhering to the fundamental pattern exhibited by the sequence of cycles.<sup>24</sup> Conversely, the displacement of a single voice occurs after both planes have been displaced; the procedure is extended one step further with the pulling apart of the two constituent instruments of a voice, resulting in a five-voice polyphony. Once each voice has been displaced, each sequence of cycles continues in its habitual linear fashion, with subsequent cycles reduced by a quarter note.

The proportional layout of materials belonging to the cycle phase, as detailed in figure 6, shows the layout of tripartite cycles throughout the section. An argument can be made, and is noted in this analysis, that the second polyphonic voice actually begins shortly after rehearsal no. 3 as the violin and cello separate from the other voices, producing the following statement (figure 7) as a means of articulating a divergence from the central homophonic voice. This earlier emergence of a polyphonic voice is not represented in figure 6 because it does not conform to the standard “A – B – Silence” model exhibited by other cycles in the first section—instead, the portion of the cycle model comprising A material is absent in the first dissenting voice of the polyphony. This consideration alone leads to a distinction between the two interpretations, which otherwise coincide.

---

<sup>24</sup> Grisey uses two techniques in order to displace the planes of activity. One is the literal shortening of a cycle, in which case the tripartite structure of the cycle is preserved, yet its overall length does not conform to the sequence of descending cycle lengths (as is seen in figure 6 label “C”); in this example, the violin sequence is brought out of alignment after the temporary injection of a cycle that is six quarter notes shorter than expected. The second method relies on halting a cycle completely, in which case the sequence is merely suspended until a later time. In such cases, a shorter, tripartite cycle does not occur between the new voice and the old from which the instrument was cut.

Figure 7. Inception of first polyphonic voice by the violin and cello between rehearsal nos. 3 and 4; no A material present.

The image shows a musical score for Violin (Fl.) and Cello (Cl.). The Violin part (top staff) begins with a triplet of eighth notes, marked 'arco alla punta' and 'flautando'. The Cello part (bottom staff) begins with a quintuplet of eighth notes, marked 'alla punta' and 'flautando'. Both parts are marked 'ppp' (pianissimo) and 'sempre' (always). The score is divided into three measures by vertical lines.

One of the most curious features of this five-voice polyphony is the occurrence of a rapid gesture labeled “très rythmé” by Grisey that occurs once in each voice (annotated in figure 8, detailed in figure 9), and is only present in the first section of the work.<sup>25</sup> This gesture occurs only once an instrument has become, or is becoming, its own independent voice in the polyphony. Not only does this figure show prominence as the articulation of an instrument’s independence within the polyphony, but is it also significant that the cycle lengths following the figure are decreased by three quarter notes with each subsequent occurrence. For instance, the figure is first observed in the piano at rehearsal no. 6, setting in motion a cycle that lasts 25 quarters. The following instance, heard in the cello at rehearsal no. 8, begins a cycle that lasts for 22 quarters. This is followed by a cycle in the clarinet that lasts for 19 quarters at rehearsal no. 10, a cycle in the viola at rehearsal no. 12 that lasts for 16 quarters, and finally a cycle between rehearsal nos. 14–15 that lasts for 13 quarters. The systematic reduction of cycle lengths with each

<sup>25</sup> The full articulation is labeled as “très rythmé, sauvagement et sans diminuer,” which translates to “very rhythmically, brutally, and without diminishing.” This label, applied to each instance of the gesture, solidifies the role of the gesture as a form of consistent articulation in the first section.

subsequent “très rythmé” figure is intimately tied to the order in which voices depart from the original homophonic voice.<sup>26</sup>

Figure 8. Assignment of instruments to the five polyphonic voices in Section I of *Talea*. Annotations indicating a recurring figure assigned the expression “très rythmé,” and cycle lengths that follow the figure, indicated below.

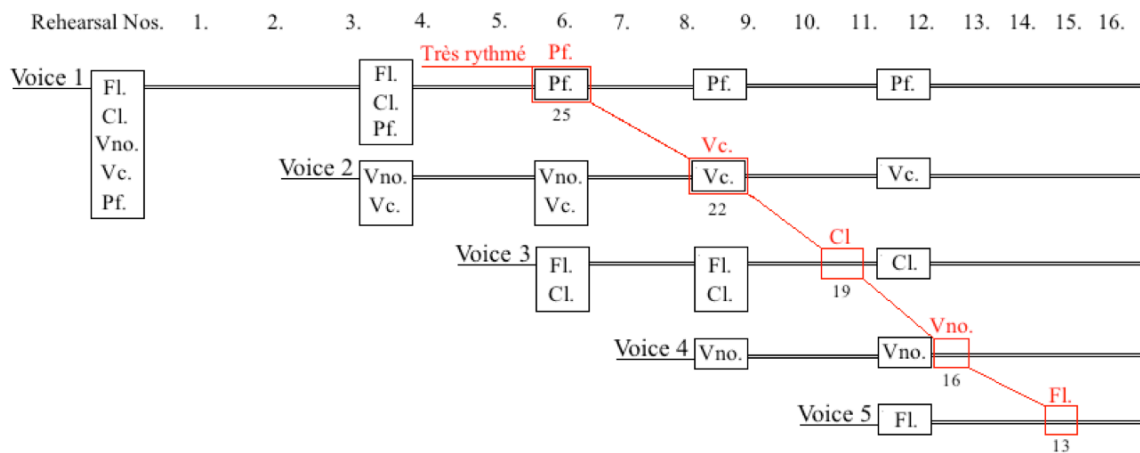

The unambiguous separation of instruments into polyphonic voices according to the above figure reveals a rather straightforward, systematic procedure for “cutting” away voices from the original homophony. This notion is strengthened by the aforementioned “très rythmé” figure, which closely follows behind the redistributed polyphonic voices and exhibits a methodical sequence of gradual reduction (just as consecutive cycles in a single voice exhibit).

<sup>26</sup> The cycle following this figure in the piano lasts for a total duration of 25 quarter notes, which is the sole anomaly in the otherwise linear shortening of cycle lengths in the piano (figure 6).

Figure 9. Similar gestures labeled “très rythmé” that occur in each instrument, arranged in the order they occur.

1. Pf. *très rythmé, sauvagement et sans diminuer.*

2. Vc. *très rythmé, sauvagement et sans diminuer.*  
*arco ORD* *arr. gettato* *ST*  
*fff* *fff* *p*

3. Cl. *très rythmé, sauvagement et sans diminuer.*  
*fff* *ffff* *mp* *mp*

4. Vno *très rythmé, sauvagement et sans diminuer.*  
*fff* *ffff* *mf senza dim.* *ST*

5. Fl. *très rythmé, sauvagement et sans diminuer.*  
*fff* *ffff* *f*

All voices depart from the original voice, while the piano is the only instrument to maintain it; it sounds as a point of reference and eventual goal for the multi-voice texture

to realign with. Recall the orientation of instruments on stage (figure 5), and the “time-keeping” designation of the piano, or original voice, throughout this process. When the polyphony is realized in three-dimensional space according to the arrangement of instruments on stage, the following symmetrical arrangement of budding polyphonic voices occurs (figure 10).

Figure 10. Symmetrical arrangement of polyphonic voice generation reflected by the position of instruments on stage.

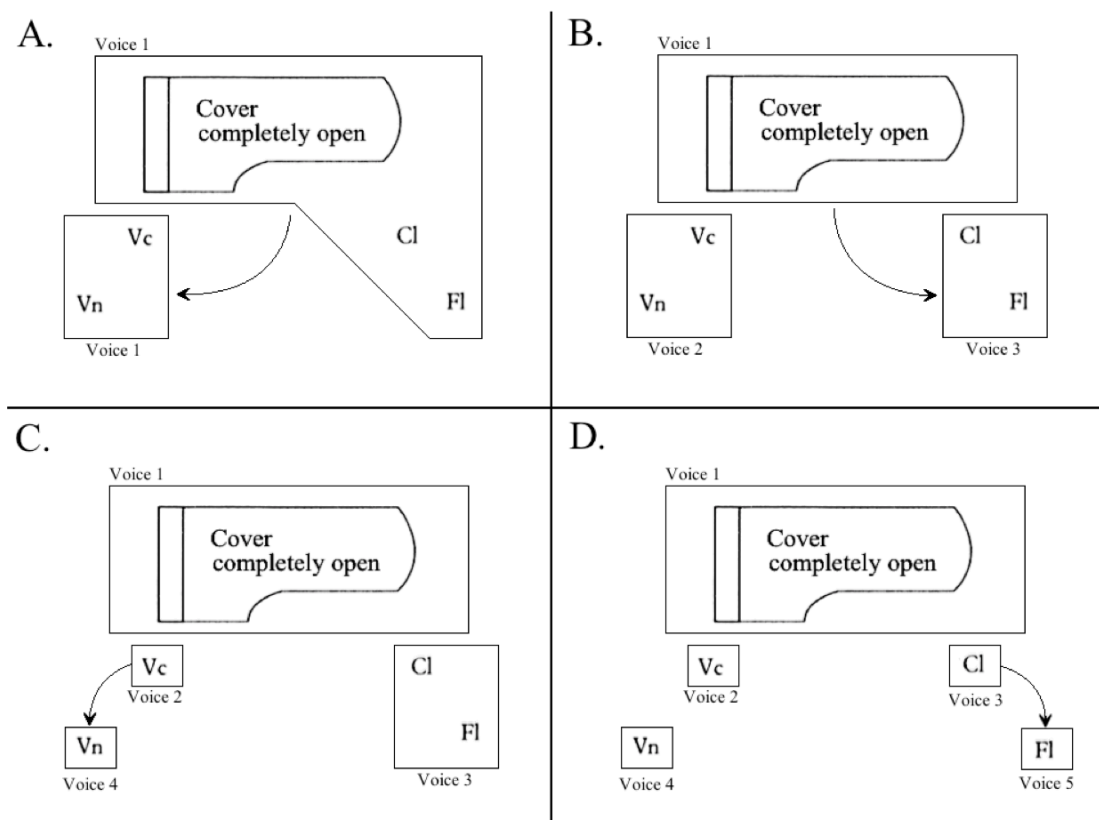

Grisey’s systematic treatment of the cycle phase becomes evident when the cycles are positioned side-by-side and the polyphony is unraveled. After Grisey’s final adjustment of the polyphony, the resultant pattern of cycle lengths brings to light an

apparent underlying logic to the composer's actions. In figure 11, the cycles of each voice are realigned to show their relationships to the other voices that occur simultaneously; the lengths of cycles between voices when read from flute to piano are sequential ascending values. For instance, at rehearsal no. 11 the lengths of overlapping cycles read: 16, 17, 18, 19, and 20.<sup>27</sup> This stepwise numerical pattern is preserved through each subsequent cycle phase (rehearsal nos. 11–16, approximately), and is preserved as each cycle is shortened.

Figure 11. Rehearsal nos. 11–16, length of cycles in each voice; cycles realigned according to simultaneity; durations measured in quarter notes.

|          |    |    |    |    |    |    |
|----------|----|----|----|----|----|----|
| Flute    | 16 | 15 | 14 | 13 | 12 | 14 |
| Clarinet | 17 | 16 | 15 | 14 | 13 | 14 |
| Violin   | 18 | 17 | 16 | 15 | 14 | 14 |
| Cello    | 19 | 18 | 17 | 16 | 15 | 14 |
| Piano    | 20 | 19 | 18 | 17 | 16 | 14 |

At the penultimate rehearsal number, no. 15, the durations between voices are 12, 13, 14, 15, and 16. The average value (and median) of this numerical set is 14, which becomes the length of the final homophonic cycle before the brief transition section that precedes Section II.

### **Diffusion / Fusion**

Upon listening, one finds that the fixed order “A – B – Silence” is frequently interrupted by brief bursts of displaced A material. First observed two measures before

---

<sup>27</sup> The ascending order of piano, cello, violin, clarinet and flute is as written in the score.

rehearsal no. 3, at the very end of the second cycle, the injection of foreign A material between the B material and silence becomes the norm. Close examination of this injected material reveals that it shares, in fact, the same rhythmic character as the A material used at the beginning of the cycle; while rapid attacks, sharp articulations, and loud dynamics are aural characteristics of A material, both events share the same rhythmic subdivision.<sup>28</sup>

This is an important distinction, as it suggests that the A material at the beginning of the cycle has been displaced, rather than added from some unrelated outside source.

Materials that occur outside of their prescribed locations in the “A – B – Silence” phrase model bring to light a systematic, progressive disintegration of the phrase model as a whole. The overall proportions of materials within each cycle, however, remain consistent. The data used in figure 3b (which outlined the proportions of materials within each cycle) is based on the total duration of each material in the cycle, regardless of its positioning in the phrase model. Figure 12 outlines the procedure used to identify these values, and reveals the source of data used in figures 3a and 3b.

Figure 12. Method used to calculate total duration of A material in cycle.

*Piano, Rehearsal No. 7*

⑦

|  |   |   |
|--|---|---|
| <p>A Material<br/>(1/7 Division)<br/>6 <math>\frac{2}{3}</math> Eighth Notes</p>                     | <p>B Material<br/>(1/3 Division)<br/>21 <math>\frac{13}{31}</math> Eighth Notes</p> | <p>A Material "Cutting"<br/>(1/7 Division)<br/>4 <math>\frac{3}{14}</math> Eighth Notes</p> |
| <p>-----</p> <p>Total Duration of A Material in Cycle 10 <math>\frac{37}{42}</math> Eighth Notes</p> |   |   |

<sup>28</sup> The A material that starts the cycle, and the A material that interrupts the B material.

As implied by the Latin definition of “*talea*,” the A material aggressively forces—or cuts—its way into the B material portion of the phrase model. As the cycle phase matures, the injection of foreign A material becomes less and less perceptible; rhythmic dilation and a systematic transformation of both rhythmic character and subdivision render the displaced A material unrecognizable (figure 13). While the subdivision of the two A materials may remain consistent, the rhythmic profile of the injected A material is influenced by its surroundings; rapid, regular flurries of pitch that had once defined the A material are now eroded, fractured and unpredictable. The contrast between the two materials, A and B, is gradually stabilized. The displaced A material progressively shares more in common with the B material (softer dynamics, slower tempo, infrequent attacks), to the point that it has diffused into the B material itself. The fusion of the two materials results in a simultaneous representation of both A and B—an ambivalent hybrid material.

Figure 13. Displaced A material as it is slowly eroded into silence.

The image shows a musical score for Violin (Vno) and Violoncello (Vc.) in treble clef. The Vno part features a melodic line with sixteenth-note patterns, marked with dynamics *pp*, *mf*, and *ppp*. Above the staff, there are three bracketed groups of six notes, each labeled with a '6'. The Vc. part features a similar melodic line with sixteenth-note patterns, marked with dynamics *pp*, *mf*, and *ppp*. Above the staff, there are three bracketed groups of five notes, each labeled with a '5'. The score is divided into two measures by a vertical bar line, with the dynamics and markings continuing across the bar line.

While Section I is predominantly bound by linear processes, it is not exclusively linear in construction. Several auxiliary processes affect the way each cycle is perceived on the surface level. Contour, for instance, is subjected to a process of alternation. While

the A and B materials are bound to their defined pitch / dynamic components, the direction of overall trajectory is not restricted to a single material. Two directions of contour—ascending and descending—alternate between cycles.<sup>29</sup> In the primitive stages of the cycle phase, any foreign A material that had been injected into the latter half of the phrase model would continue in the same direction as the B material that preceded it, resulting in a single arch-shaped contour per cycle. As the first section progresses, the rate of alternation quickens; each unidirectional trajectory is altered, often resulting in multiple arch-shape contours within a single cycle. The technique of “cutting” or displacing material within a cycle (first demonstrated in figure 12) serves as a vehicle for rapid changes in trajectory. The injection of A material, in particular, often influences a sudden change in direction. Figure 14 depicts an intermediary state, where the rate of alternation is starting to become more active—the melodic contour of the cycle is forced in contrary motion after a portion of A material “cuts” into the B material.

Figure 14. Contour of the flute and clarinet in voice 2, between rehearsal nos. 6–7.

The figure shows a musical score for Flute (Fl.) and Clarinet (Cl.) in voice 2. The score is divided into four sections by brackets above the staves, labeled 'Ascending', 'Descending', 'Descending', and 'Ascending'. The first section is labeled 'A Material' and the second section is labeled 'A Material, "Cutting", Changing Directions'. The score includes dynamic markings such as *ff*, *pp*, and *mp*, and articulation marks like accents and slurs. The Flute part is in the upper staff and the Clarinet part is in the lower staff. The score shows a complex melodic contour with many notes and rests, indicating a rapid alternation of direction.

One cannot overlook the contour of the B material throughout the opening section; just as the A material alternates, so too does the B material. Relative to the rapid,

<sup>29</sup> As a general trend, each material will have its own contour. In the early stages of the first section, the overall contour of each cycle is a single arch: one material ascends while the other descends, and vice versa.

instantaneous exposition of the A material, the acoustic impact of the slowed B material moving in contrary motion is significant from an aural standpoint because it gives the impression of a sound that is either slowed down or sped up. In electroacoustic music, the technique of “time stretching” enables a sound to be prolonged without affecting its frequency, which ultimately allows for the inner components of a sound to become more perceptible.<sup>30</sup> As Grisey claims: “It has, in fact, become imaginable to explore the interior of a sound by stretching its duration...”<sup>31</sup> Since the B material is primarily derived from pitches introduced by the A material, its long, drawn-out representation is likely the product of a temporal elasticity. While the technique detailed earlier retains the original frequency as it is elongated, the changing contours of the B material give rise to a literal change in frequency analogous to the slowing down or speeding up of a vinyl record or magnetic tape—a phenomenon well understood by Grisey after nearly two decades in the electronic studio. These frequency shifts, much like the Doppler effect, are proportional; a spectrogram of the opening music reveals that the B material is stratified, visually indicative of a pseudo-spectrum construction. The deceleration of time and decrease in frequency is detailed at the points labeled “A” in figure 15, while the acceleration of time and increase in frequency is detailed at “B”.

---

<sup>30</sup> Huey-Meei Chen, “Temporality and Process in the Compositions of Gérard Grisey” (PhD diss., Columbia University, 2010), 9.

<sup>31</sup> Gérard Grisey, *Écrits ou l'invention de la musique spectrale*, eds. Guy Lelong and Anne-Marie Réby, translated by author (Paris: MF Éditions, 2008), 35, quoted in *ibid.*, 9.

Figure 15. Spectrogram of opening music (excerpt), with B material accelerations, “B,” and decelerations, “A,” annotated.

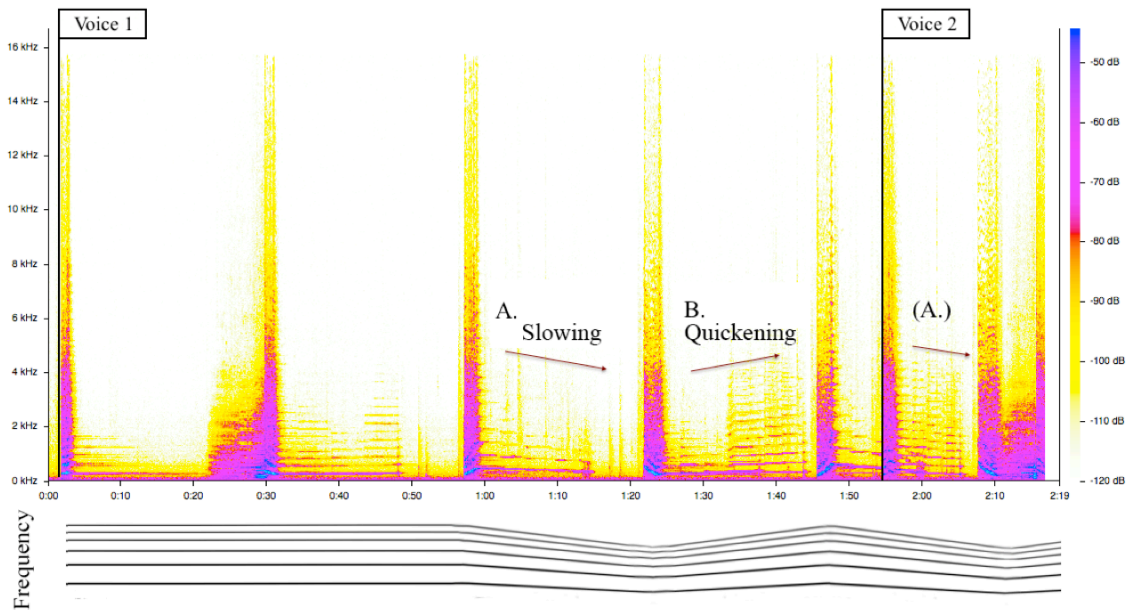

The rhythmic character of the A material in the original voice is systematically changed over the course of the section. The subdivision of the beat is subjected to a process of enlargement, moving from a  $1/10^{\text{th}}$  division of the beat to a  $1/3^{\text{rd}}$  division (figure 16). In *Partiels*, Grisey employs a similar technique; a subtle, linear change in subdivision results in an imperceptible rhythmic transformation. The human ear’s inability to perceive rhythmic events spaced less than 55 milliseconds apart will cause the rhythmic alteration detailed above to go unnoticed between consecutive cycles.<sup>32</sup> While the omnipresence of the original voice serves as a time-keeping mechanism, it also slows down select aspects of time while subsequently rearticulating newer, shorter cycles in a

<sup>32</sup> Christopher Arrell, “Pushing the Envelope: Art and Science in the Music of Gérard Grisey, Part II” (D.M.A. diss., Cornell University, 2002), 55.

more frequent and periodic fashion. Other instruments allude to the possibility of linear development, but do not unfold according to the regularity seen in the original voice.

Figure 16. Subdivisions of the A material in the original voice (piano).

|             |     |      |      |     |     |     |     |     |     |     |     |     |     |     |     |     |
|-------------|-----|------|------|-----|-----|-----|-----|-----|-----|-----|-----|-----|-----|-----|-----|-----|
| Cycle       | 1   | 2    | 3    | 4   | 5   | 6   | 7   | 8   | 9   | 10  | 11  | 12  | 13  | 14  | 15  | 16  |
| Subdivision | 1/3 | 1/10 | 1/10 | 1/9 | 1/9 | 1/8 | 1/8 | 1/7 | 1/7 | 1/6 | 1/6 | 1/5 | 1/5 | 1/4 | 1/4 | 1/3 |

By the 16<sup>th</sup> cycle, the sequence of rhythmic subdivisions has arrived at its starting point. The 1/3 subdivision that started Section I, while it did seem like an anomaly at the time, foreshadows the rhythmic “end result” of the A material that occurs as the cycle phase reaches completion. The progressive expansion of rhythmic subdivision operates hand-in-hand with a gradual progression, in pitch, from closely packed higher partials to more openly spaced lower partial tones.

## Pitch

One of the incontrovertible benefits of spectral analysis is the ability to observe a sound’s *natural* qualities, which opens up the possibility for the alteration of a sound’s sonic character, timbre, in a manner that gives the illusion of some sequential harmonic change. The two qualities are synonymous, as Kari Besharse points out: “spectral composers saw harmony and timbre as two aspects of a single phenomenon and wanted to control the finest degrees of change by blurring the division between harmony and timbre.”<sup>33</sup> Since timbre and harmony are two sides of the same coin, a hierarchy of sound

---

<sup>33</sup> Kari Besharse, “The Role of Texture in French Spectral Music” (D.M.A. diss., University of Illinois at Urbana-Champaign, 2009), 19.

colors can be inferred, established, and used for the purpose of articulating form. The extent to which a particular sound color aligns with the spectrum it is meant to imitate, for instance, provides a sense of referential harmonicity; since the produced sound will be either more sonorous or more distorted relative to the emulated sound, contrast is clearly perceptible. A sonority built from the partial tones of a sound relies heavily on the positioning of designated pitches along a spectrum for recognition of the fundamental tone; timbres built from tones (partials) closer to the fundamental will bear more of a resemblance to the principal tone, while higher fundamentals are not unique to the fundamental tone and resemble, rather, distorted pitches. The pitch content of the first section in *Talea* is derived from the overtone series built on a fundamental  $C^1$ . Figure 17 outlines a basic spectrum built on  $C^1$ , with tones of the series rounded to the nearest eighth of a tone.

Figure 17. The first 32 tones of the harmonic series based on  $C^1$ , rounded to the nearest eighth of a tone.

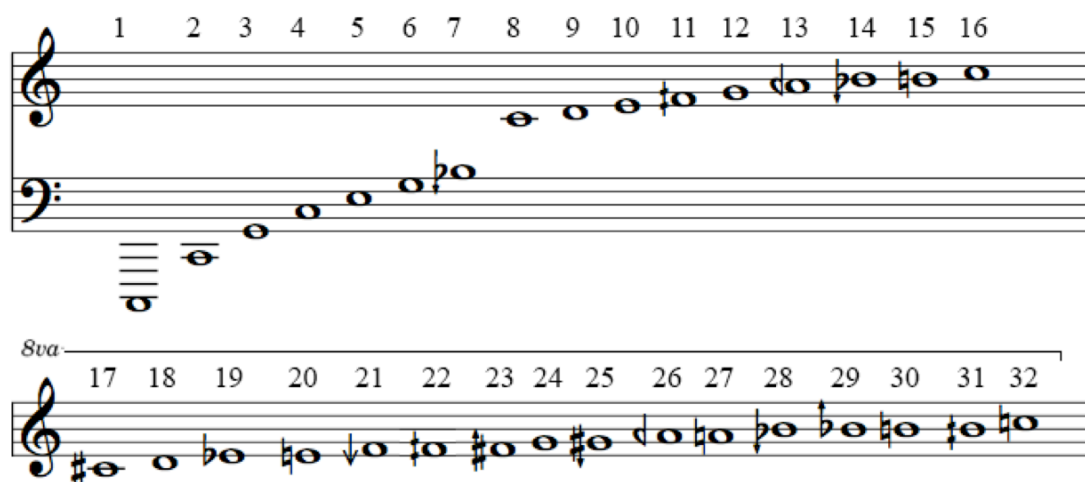

Since the overall objective of the first section is a consolidation of several linear processes in a fashion that communicates a large-scale progression, it is only fitting that the pitch content reflects this evolution; by moving from higher partials down to those closest to the fundamental tone, Grisey reveals the identity of the underlying tone at the culmination of several separate but closely related processes. The large-scale progression from inharmonicity to pitch is also reflected in this operation.

As demonstrated in figure 17, the higher partials of the overtone series may be rounded off to the nearest tempered pitch (using standard Tartini-Couper notational conventions for quarter tones, as well as arrows to indicate pitches that are raised and lowered an eighth of a tone) despite a progressive deviation from the tempered scale as the overtones ascend. Without special retuning, the piano is capable only of producing tempered pitches. The other instruments, either unfretted or capable of microtonal extended technique, are able to produce the eighth tones required to accurately imitate higher-partial tones that deviate from those in tones of the tempered scale. The amount of registral space occupied by each statement of the A material is predominantly identical between each instrument participating in a single voice of the polyphony. The way in which this space is divided varies depending on instrument; each partitions the space according to its own unique subdivision. Because the other instruments are capable of performing what the piano cannot—namely, microtones—their pitch content functions primarily as a supplement to the piano's crude representation of the spectrum in the first voice. In this sense, the other instruments play overtones above the 32nd tone of the harmonic series, which are transposed down to an inharmonic register. As other voices are pulled from the original homophonic voice in pairs, one instrument of the duo

provides a crude representation of the spectrum while the other instrument plays the aforementioned inharmonic tones in a way that distorts the perception of the other instrument. This is evident (as detailed in figure 18), as the pitches of the other instruments operate within the same span as those of the piano, but deviate from a tempered scale. Just as the piano's pitches provide a crude representation of the highest partial tones currently in focus at that point in the cycle process, similar tones found in the divergent voices of the polyphony also provide reliable placemarkers for the position on the spectrum that is currently in focus.

Figure 18. Pitch content of the A material in the first three cycles of voice 1, all instruments.

A. Cycle 1

B. Cycle 2, rehearsal no. 1

C. Cycle 3, rehearsal no. 2

Figure 18 displays three musical cycles (A, B, and C) for voice 1, showing the pitch content of the A material across five instruments: Flute (Fl.), Clarinet (Cl.), Violin (Vno.), Viola (Vc.), and Piano (Pf.).

- A. Cycle 1:** Shows the first cycle. The piano part (Pf.) moves chromatically. Other instruments (Fl., Cl., Vno., Vc.) play inharmonic tones. Dynamics include *fff*, *ppp*, and *pppp*. Performance markings include *sana réels*, *arco tremolo SP*, and *arco nettato*.
- B. Cycle 2, rehearsal no. 1:** Shows the second cycle. The piano part continues its chromatic movement. Dynamics include *fff*, *ppp*, and *pppp*. Performance markings include *arco tremolo SP* and *tr*.
- C. Cycle 3, rehearsal no. 2:** Shows the third cycle. The piano part continues its chromatic movement. Dynamics include *fff* and *pppp*. Performance markings include *arco trem SP*.

In the first voice, the piano moves chromatically while the other instruments fill in the space between the tones of the tempered scale. This phenomenon occurs in each voice

of the polyphony that comprises more than one instrument. As discussed prior, a single instrument outlines a discernible portion of the harmonic series (figure 19a), while an additional instrument distorts the perception of this portion of the series by transposing higher partials down to an inharmonic register (figure 19b, c). In the latter portion of Section I, each instrument has been assigned its own voice within the polyphony and is no longer distorted by additional instruments participating in the voice—the distorted component of each polyphonic voice has effectively been stripped, or “cut,” from it.<sup>34</sup> In voice 3, the clarinet sporadically provides non-linear inharmonic tones outside those outlined by the flute (figure 19b), while in voice 2 the cello performs a glissando as a means of obscuring the tones outlined by the violin (figure 19c).

Figure 19. Segments of the overtone series outlined at the onset of voices 2 and 3.

A. Upper partial content of the flute immediately before rehearsal no. 7, with corresponding tones of the overtone series.<sup>35</sup>

The image displays two musical staves. The upper staff, labeled '8va', shows a sequence of notes numbered 13 through 28, representing the upper partials of an overtone series. The lower staff, labeled 'Fl.', shows the flute's performance of these notes. A dashed line connects a note in the flute staff to a note in the overtone series staff, with the label '+/- 25 cents' indicating a discrepancy. The flute staff includes dynamic markings: *ff* and *ff* *pp*.

<sup>34</sup> Voices 1, 2, and 3 comprise more than one instrument and exhibit this feature of “added” dissonance until the additional instrument(s) participating in the voice have been removed and assigned to a new voice in the polyphony.

<sup>35</sup> This discrepancy regarding the “F” that is one quarter tone sharp is likely due to a natural limitation of the instrument. Joël-François Durand has pointed out to me that the flute is incapable of producing this particular microtone.

B. Voice 2: violin provides tones of the series, while the cello fills in the pitch space, generating inharmonicity (highest partial tones, transposed).

The musical score for Voice 2 consists of two staves. The top staff is for the Violin (Vno.) and the bottom staff is for the Cello (Vc.). Both staves are in treble clef and contain a series of notes with dynamic markings of *fff* and *fff pp*. Above the Vno. staff, there are two horizontal lines labeled 'SP' connected by a line, with the instruction 'AST flautando' written below them. Above the Vc. staff, there are two horizontal lines labeled 'ASP' connected by a line, with the instruction 'AST flautando' written below them. The Vc. staff also features several triplets of notes, each marked with a '3' above the notes.

C. Voice 3: flute provides tones of the series, while the clarinet generates inharmonicity (highest partial tones, transposed).

The musical score for Voice 3 consists of two staves. The top staff is for the Flute (Fl.) and the bottom staff is for the Clarinet (Cl.). Both staves are in treble clef and contain a series of notes with dynamic markings of *fff* and *fff pp*. Above the Fl. staff, there are two horizontal lines labeled '9' connected by a line, with a bracket above the notes. Above the Cl. staff, there are two horizontal lines labeled '5' connected by a line, with a bracket above the notes.

In the first section of *Talea*, the overall pitch collection of a cycle is enlarged slowly with each subsequent cycle; as pitch collections become larger, their contents change. Over the course of the 16 cycles of the first section (and rehearsal no. 16 onward, the first ostinato indicated by the tutti), Grisey derives his pitch content from the highest end of a spectrum down to the lowest partials. In the first voice (figure 18), second voice (figure 19c), and ensuing third voice (figure 19b), the exact locus of the harmonic series being represented is found in at least one instrument per voice. By the time each

instrument is assigned its own voice, their respective pitch content aligns rather tidily with the harmonic series. These collections exhibit a straightforward progression as the piece unfolds—a predominant feature of the first section is a gradual expansion of the space between adjacent tones: from microtones, to quarter tones and eventually to tempered pitches in the latter portion of the section. With regard to the fundamental tone, C, the first section of the piece moves from the completely unrecognizable toward the most identifiable portions of the spectrum while simultaneously enlarging the overall collection in registral space.

As the voices move into phase, the collective voice is decidedly more active than the original voice at the start of the piece—the progressive blending of A material, B material, and silence within each cycle brought about heightened activity, as the standard archetype of the cycle in the latter portion of Section 1 takes the form of an oscillating, wave-like ostinato. With each voice participating in this ostinato, the stratification of instruments brings to light an underlying, registraly significant pitch structure indicative of the harmonic series.<sup>36</sup>

---

<sup>36</sup> While the harmonic series seems to be registraly fixed, Grisey injects a G<sup>1</sup> above C<sup>1</sup>, which obscures the presumed harmonic series, suggesting that C<sup>0</sup> is in fact the actual fundamental tone despite its absence in the music (and despite the fact that it cannot be played by any of the instruments on stage). Instead, the progression from the highest partials to the lower partials is reflected in the pitch content—a registraly fixed representation of the harmonic series is only loosely applicable, although the stratification of the overlapping pitch collections does imitate the series.

Figure 20. Pitch content of pre-ostinato “wave” gestures at the end of Section 1, with approximate range of harmonic series tones annotated.

The musical score for Figure 20 consists of five staves, each representing a different instrument. The staves are labeled as follows:

- Fl. (Flute):** Tones 8-32. The notation shows a series of notes with slurs and accents, indicating a wave-like gesture. Dynamics range from *pp* to *ff*.
- Cl. (Clarinet):** Tones 5-29. Similar to the flute, it shows a wave-like gesture with slurs and accents. Dynamics range from *pp* to *ff*.
- Vno. (Violin):** Tones 6-32. The notation shows a series of notes with slurs and accents. Dynamics range from *pp* to *ff*.
- Vc. (Viola):** Tones 4-8. The notation shows a series of notes with slurs and accents. Dynamics range from *pp* to *ff*.
- Pf. (Piano):** Tones 2-3. The notation shows a series of notes with slurs and accents, indicating a clear progression of pitch material. Dynamics range from *pp* to *ff*.

The score is divided into two systems, with a measure number '32' at the top. The piano part shows a clear progression of pitch material, with notes moving from a lower register to a higher register, indicating a progression toward its ostensible goal in the harmonic series.

The piano, which provides pitch material closest to the fundamental C, exhibits a very clear progression toward its ostensible goal in the harmonic series (figure 21a). A pitch reduction showing the final four cycles of the piano (two cycles out of phase, and two cycles participating in an ostinato with the other instruments) makes the concluding steps of the process visible (figure 21).

Figure 21. Pitch content of the final four cycles of the piano (voice 1) as the partials approach the fundamental tone.

A.

B.

## Conclusion

In *Talea*, the musical object is a collection of parameters, kept in motion by the ongoing transition from one musical quality to its respective antithesis. Each cycle is a metaphor. Its tripartite structure imitates the production and physics of a sound: a compression that is followed by a rarefaction before returning to the neutral state of silence. This musical subject of the first section, much like the production of any sound, is constantly changing and unlike any other iteration. Each of the sound object's parameters, such as dynamics, subdivision, timbre, overtone content, tempo and periodicity, are constantly fluctuating from one end of a "spectrum" to the other. Grisey

referred to this state of constant change as “the principle of instantaneous generation,”<sup>37</sup> where a musical subject gives rise to a more developed, expanded form of itself with each subsequent stage of a process. To this end, the sound object is evolving in the service of self-discovery and comprehension. Each linear process may seem mechanical, but the natural influence for each dichotomy promotes an organic, unified sound object—a macrocosmic representation of a microscopic phenomenon, to quote Arrell once more. By exploiting the space between two seemingly opposed forces, the composer brings to light the underlying unity of his musical materials and their interrelatedness within a single sound object. The unique matrix of interconnected parameters in *Talea* effectively satisfies Grisey’s desire to “express two aspects or, more precisely, two auditory angles of a single phenomenon.”<sup>38</sup>

---

<sup>37</sup> “Le principe de la génération instantanée.” Gérard Grisey, “La musique: le devenir des sons,” *Conséquences*, quoted in Viviana Moscovich, “French Spectral Music: An Introduction,” *Tempo*, no. 200 (April 1997), 25.

<sup>38</sup> Preface to Gérard Grisey, *Talea* (Milan, Italy: Ricordi, 2009), n.pag.

## Sources Cited

- Anderson, Julian. "A provisional history of spectral music." *Contemporary Music Review* 19, no. 2 (August 2009): 7–22.
- Archibald, Bruce. "Some Thoughts on Symmetry in Early Webern: Op. 5, No. 2." *Perspectives of New Music* 10, no. 2 (Fall 1972): 159–63.
- Arrell, Christopher. "Pushing the Envelope: Art and Science in the Music of Gérard Grisey, Part II." D.M.A. diss., Cornell University, 2002.
- \_\_\_\_\_. "The Music of Sound: An Analysis of *Partiels* by Gérard Grisey." *Spectral World Musics: Proceedings of the Istanbul Spectral Musics Conference*. Istanbul, Turkey: Pan Yayıncılık, 2008, 318–333.
- Baggech, Melody. "An English Translation of Olivier Messiaen's *Traité de Rythme, de Couleur, et d'Ornithologie*, volume 1." D.M.A. diss., University of Oklahoma, 1998.
- Bailey, Kathryn, ed. *Webern Studies*. Cambridge, England: Cambridge University Press, 1996.
- Bailey, Kathryn. *The Twelve-Tone Music of Anton Webern: Old Forms in a New Language*. Cambridge: Cambridge University Press, 1991.
- \_\_\_\_\_. "Symmetry as Nemesis: Webern and the First Movement of the Concerto, Opus 24." *Journal of Music Theory* 40, no. 2 (1996): 245–310.
- Besharse, Kari. "The Role of Texture in French Spectral Music." D.M.A. diss., University of Illinois at Urbana-Champaign, 2009.
- Brown, Robert Barclay. "The Early Atonal Music of Anton Webern: Sound Material and Structure." PhD diss., Brandeis University, 1965.
- Bruhn, Siglind, ed. *Messiaen's Language of Mystical Love*. London: Garland Publishing, 1998.
- Bruhn, Siglind. *Messiaen's Interpretations of Holiness and Trinity*. Hillsdale: Pendragon Press, 2008.
- Castanet, Pierre Albert. "Gérard Grisey and the Foliation of Time." *Contemporary Music Review* 19, no. 3 (2000): 29–40.

- Chen, Huey-Meei. "Temporality and Process in the Compositions of Gérard Grisey." PhD diss., Columbia University, 2010.
- Cochran, Timothy B. "The Pebble in the Water: Messiaen, Debussy and the Meaning of Rhythmic Contrast." *Journal of Musicology* 31, no. 4 (Fall 2014): 503–540.
- Cohen-Levinas, Danielle. "Combinatoire Sérielle, Maïeutique Spectrale: Une généalogie du matériau." *Musurgia* 3, no. 3: *La création musicale et l'analyse aujourd'hui* (1996): 81–89.
- Féron, François-Xavier. "The Emergence of Spectra in Gérard Grisey's Compositional Process: From *Dérives* (1973–74) to *Les espaces acoustiques* (1974–85)." *Contemporary Music Review* 30, no. 5 (April 2012): 343–375.
- Fineberg, Joshua. "Spectral Music." *Contemporary Music Review* 19, no. 2 (2000): 2.
- Griffiths, Paul. *Oliver Messiaen and the Music of Time*. Ithaca: Cornell University Press, 1985.
- Dingle, Christopher, Robert Fallon, eds. *Messiaen Perspectives 1: Sources and Influences*. Surrey, UK, and Burlington, Vt: Ashgate Publishing Limited, 2013.
- \_\_\_\_\_. *Messiaen Perspectives 2: Techniques, Influence and Reception*. Surrey, UK, and Burlington, Vt: Ashgate Publishing Limited, 2013.
- Donelson, Jennifer. "Musical Technique and Symbolism in *Noël* from Oliver Messiaen's *Vingt Regards sur l'Enfant-Jésus*: A Defense of Messiaen's Words and Music." D.M.A. diss., University of Nebraska, 2008.
- Erpf, Herman. *Studien zur Harmonie- und Klangtechnik der neueren Musik*. Leipzig: Breitkopf & Härtel, 1927.
- Forte, Allen. *The Atonal Music of Anton Webern*. New Haven: Yale University Press, 1998.
- \_\_\_\_\_. "The Golden Thread: Anton Webern's Early Songs." In *Webern Studies*. Edited by Kathryn Bailey, 74–110. Cambridge: Cambridge University Press, 1996.
- Freeman, Robin. "Trompette d'un Ange Secret: Olivier Messiaen and the Culture of Ecstasy." *Contemporary Music Review* 14, nos. 3–4 (August 2009): 81–125.
- Friedmann, Michael. "A Methodology for the Discussion of Contour: Its Application to Schoenberg's Music." *Journal of Music Theory* 29, no. 2 (Autumn 1985): 223–248.
- Govers, Klaas. "Religious Music: Its time and reality." *Contemporary Music Review* 12, no. 2 (August 1995): 117–123.

- Grisey, Gérard. *Talea*. Milan, Italy: Ricordi, 2009.
- \_\_\_\_\_. "Did you say spectral?" *Contemporary Music Review* 19, no. 3 (2000): 1–3.
- \_\_\_\_\_. *Écrits ou l'invention de la musique spectrale*, eds. Guy Lelong and Anne-Marie Réby, translated by author. Paris: MF Éditions, 2008.
- \_\_\_\_\_. "Tempus ex Machina: a composer's reflections on musical time." *Contemporary Music Review* 2, no. 1 (1987): 241–247.
- Hanson, Robert. "Webern's Chromatic Organization." *Music Analysis* 2, no. 2 (1983): 135–149.
- Harley, Maria Anna. "To be God with God: Catholic Composers and the Mystical Experience." *Contemporary Music Review* 12, no. 2 (August 1995): 125–145.
- Harper, Steven A. "Contour and Melodic Structure in Two Homophonic Instrumental Works by Anton Webern." *College Music Symposium* 46 (2006): 105–122.
- Healey, Gareth. *Messiaen's Musical Techniques: The Composer's View and Beyond*. Surrey, UK, and Burlington, Vt: Ashgate Publishing Limited, 2013.
- Hepokoski, James, and Warren Darcy. *Elements of Sonata Theory: Norms, Types, and Deformations in the Late Eighteenth-Century Sonata*. Oxford, England: Oxford University Press, 2006.
- Hill, Peter, and Nigel Simeone. *Messiaen*. New Haven: Yale University Press, 2005.
- Hill, Peter, ed. *The Messiaen Companion*. London: Faber and Faber, 1995.
- Imberty, Michel. "Aspects du temps dans la création musicale." *Musicae Scientiae: Forum de Discussion* 3 (2004): 7–19.
- Johnson, Julian. *Webern and the Transformation of Nature*. Cambridge: Cambridge University Press, 1999.
- Kabbash, Paul. "Aggregate-Derived Symmetry in Webern's Early Works." *Journal of Music Theory* 28, no. 2 (1984): 225–250.
- Koozin, Timothy. "Spiritual-Temporal Imagery in Music of Olivier Messiaen and Toru Takemitsu." *Contemporary Music Review* 7, no. 2 (January 1993): 185–202.
- Mead, Andrew. "'Tonal' Forms in Arnold Schoenberg's Twelve-Tone Music." *Music Theory Spectrum* 9 (1987): 67–92.
- Messiaen, Olivier. *Traité de Rythme, de Couleur, et d'Ornithologie*, 7 vols. Paris: Alphonse Leduc, 1994.
- Moscovich, Viviana. "French Spectral Music: An Introduction." *Tempo*, no. 200 (April 1997): 21–27.

- Morris, Robert D. "New Directions in the Theory and Analysis of Musical Contour." *Music Theory Spectrum* 15, no. 2 (1993): 205–228.
- Murail, Tristan. "After-thoughts," *Contemporary Music Review* 19, no. 3 (2000): 5–9.
- \_\_\_\_\_. "The Revolution of Complex Sounds." *Contemporary Music Review* 24, nos. 2–3 (January 2007): 121–135.
- Perle, George. *Serial Composition and Atonality; an Introduction to the Music of Schoenberg, Berg, and Webern*. Berkeley, CA: University of California, 1962.
- Randel, Don Michael, ed. *The Harvard Dictionary of Music*, 4<sup>th</sup> ed. Cambridge: Harvard University Press, 2003.
- Rose, François. "Introduction to the Pitch Organization of French Spectral Music." *Perspectives of New Music* 34, no. 2 (Summer 1996): 6–39.
- Samuel, Claude. *Conversations with Olivier Messiaen*. Translated by Felix Aprahamian. London: Stainer & Bell Limited, 1976.
- Schloesser, Stephen. *Visions of Amen: The Early Life and Music of Olivier Messiaen*. Cambridge: William B. Eerdmans Publishing, 2014.
- Schoenberg, Arnold. *Theory of Harmony*. Edited by Roy Carter. Englewood Cliffs: Prentice Hall, 1967.
- \_\_\_\_\_. *Fundamentals of Musical Composition*. Edited by Gerald Strang. New York: St. Martin's Press, 1967.
- Shenton, Andrew. *Oliver Messiaen's System of Signs*. Surrey, UK, and Burlington, Vt: Ashgate Publishing Limited, 2008.
- Sholl, Robert, ed. *Messiaen Studies*. Cambridge: Cambridge University Press, 2007.
- Smalley, Roger. "Webern's Sketches (I)." *Tempo*, no. 112 (March 1975): 2–12.
- \_\_\_\_\_. "Webern's Sketches (II)." *Tempo*, no. 113 (June 1975): 29–40.
- Straus, Joseph Nathan. "Analysis 3: Webern, *Movements for String Quartet* Op. 5, No. 4." In *Introduction to Post-tonal Theory*. 3rd ed. Upper Saddle River, NJ: Prentice Hall, 2000.
- Webern, Anton. *The Path to the New Music*. Edited by Willi Reich, translated by Leo Black. Bryn Mawr, PA: Theodore Presser, 1963.