

© Copyright 2022

Kelsey Foster

Power and Energy Implications for Electrification of the UW Transportation Vehicle Fleet

Kelsey Foster

A thesis

submitted in partial fulfillment of the
requirements for the degree of

Master of Science in Electrical Engineering

University of Washington

2022

Committee:

Daniel Kirschen

Baosen Zhang

Program Authorized to Offer Degree:

Electrical and Computer Engineering

University of Washington

Abstract

Power and Energy Implications for Electrification of the UW Transportation Vehicle Fleet

Kelsey Foster

Chair of the Supervisory Committee:
Dr. Daniel Kirschen
Electrical and Computer Engineering

As climate change and greenhouse gas emissions become an increasing concern, there is a push for phasing out traditional combustion engine vehicles and replacing them with electric vehicles. The University of Washington has ambitious carbon emissions reduction plans including electrification of the UW Transportation vehicle fleet of over 500 vehicles. To successfully accommodate an electrified fleet with minimal cost implications and infrastructure upgrades, UW Transportation must deploy charge management and charge scheduling techniques to minimize energy, power, and charger requirements for the fleet. This thesis analyzes several strategies for when and where to charge electric vehicles in the UW Transportation fleet. As a result, charging every fleet vehicle every weekday and splitting charging between weekdays and weekends are the best options. The approach used in this analysis can be expanded to apply to other fleets using the UW Transportation fleet as a case study.

TABLE OF CONTENTS

List of Figures	iv
List of Tables	vi
List of Acronyms	vii
Introduction.....	10
1.1 Thesis Overview	10
Chapter 2. Prior work.....	12
2.1 UW Solar Transportation Electrification Report	12
2.1.1 UW Solar Transportation Electrification Report: Background	13
2.1.2 UW Solar Transportation Electrification Report: EV Costs.....	13
2.1.3 UW Solar Transportation Electrification Report: Survey of Fleet Users	15
2.1.4 UW Solar Transportation Electrification Report: Charging	15
2.1.5 UW Solar Transportation Electrification Report: Takeaways	16
2.2 Managed Electric Vehicle Charging Capstone Project.....	17
2.2.1 Managed Electric Vehicle Charging Capstone: Overview	18
2.2.2 Managed Electric Vehicle Charging Capstone: System Specifications	19
2.2.3 Managed Electric Vehicle Charging Capstone: Methods and Design.....	19
2.2.4 Managed Electric Vehicle Charging Capstone: Analysis and Results	25
2.2.5 Managed Electric Vehicle Charging Capstone: Conclusion.....	34
Chapter 3. Methods and Procedure.....	37

3.1	Data Collection Methods	37
3.2	Vehicle and Charger Visualization Methods	38
3.3	Energy, Power, and Cost Calculation Procedure	39
3.3.1	Initial Calculations	39
3.3.2	Energy Calculation Procedure	41
3.3.3	Power Calculation Procedure.....	43
3.3.4	Cost Calculation Procedure.....	44
Chapter 4. Analysis and Results		48
4.1	Vehicle Trends	48
4.1.1	Fleet Vehicle Composition	48
4.1.2	Fleet Vehicle Locations	50
4.2	Charging Scenarios	53
4.2.1	Case 1: No Charge Scheduling and No Charge Management	54
4.2.2	Case 2: Charge Scheduling and No Charge Management	57
4.2.3	Case 3: Charge Management and No Charge Scheduling, Charge Every Vehicle Every Day	59
4.2.4	Case 4: Charge Management and No Charge Scheduling	60
4.2.5	Case 5: Charge Management and Charge Scheduling.....	61
4.2.6	Case 6: Weekend Charging.....	63
4.2.7	Case 7: Charge Half the Fleet Each Day	64
4.3	Cost analysis	66
4.4	UW Transportation Fleet Vehicle Usage Survey.....	68

Chapter 5. Conclusion and Future Work	70
5.1 Case Comparisons.....	70
5.2 Infrastructure Implications.....	75
5.3 Recommendations.....	81
5.4 Future Work.....	82
Bibliography	86

LIST OF FIGURES

Figure 2.1. Software System Architecture	21
Figure 2.2. SteVe Charging Profile.....	22
Figure 2.3. Simulated EV Charger.....	23
Figure 2.4. Capstone Test Setup	24
Figure 2.5. Power Schedule for the UW Transportation Electrified Fleet.....	28
Figure 2.6. Charging Schedule from Software Tool.....	29
Figure 2.7. E1 and E18 Solar Canopy Design	30
Figure 2.8. Average Power Generation from the E1/E18 Solar Canopy	30
Figure 2.9. Atom Power EVSE Design	31
Figure 2.10. Capstone Break-even Analysis for UW Transportation Electrification	34
Figure 2.11. Recommended Procedure for Fleet Electrification	35
Figure 4.1. Number of UW Transportation Vehicles from 2012 to 2021.....	49
Figure 4.2. Percentage of each Vehicle Type each Year	50
Figure 4.3. UW Transportation Vehicle Locations 2022.....	51
Figure 4.4. UW Transportation Vehicle Locations 2032.....	52
Figure 4.5. N26 and E2 Parking Lots	53
Figure 4.6. Year 10 Chargers per Parking Lot for Case 1	55
Figure 4.7. Chargers per Parking Lot Each Year for Case 1	56
Figure 4.8. Chargers per Parking Lot Each Year for Case 2	58
Figure 4.9. Year 10 Power and Energy Required to Charge Each Day for Case 2	58
Figure 4.10. Chargers per Parking Lot Each Year for Case 3	59
Figure 4.11. Year 10 Total Power each Day for Case 5	61
Figure 4.12. Year 10 Total Chargers each Day for Case 5	62
Figure 4.13. Chargers per Parking Lot Each Year for Case 5	62
Figure 4.14. Chargers per Parking Lot Each Year for Case 6	64
Figure 4.15. Chargers per Parking Lot Each Year for Case 7	65
Figure 4.16. Costs of the Original versus Electrified Fleet.....	67

Figure 4.17. Fleet Vehicle Usage..... 69

Figure 5.1. Power and Energy Requirements for Each Charging Scenario..... 70

Figure 5.2. Parking Lot Existing Load Energy 76

Figure 5.3. Total Campus Power per Month..... 77

Figure 5.4. Electrified Fleet Hourly Load..... 78

Figure 5.5. Total Hourly Campus Load Including Electrified Fleet Load..... 79

Figure 5.6. Total Load for Unmanaged Scheduled Charging..... 80

Figure 5.7. Total Load for Weekend Charging..... 80

LIST OF TABLES

Table 2.1 Capstone System Specifications	19
Table 2.2. Electric Replacement Vehicles	26
Table 2.3. AC L2 Compatible Vehicles Charging Schedule	27
Table 2.4. DC Fast Charging Compatible Vehicles Charging Schedule	28
Table 2.5. Electric Vehicle Charging Infrastructure and Costs for 120 Parking Spaces ..	32
Table 2.6. Year 1 Total Cost for an Electrified Fleet.....	33
Table 3.1 Fixed and Recurring Vehicle Costs	44
Table 3.2. Fuel Usage for the 2018 Fleet.....	46
Table 4.1. Unscheduled Charging Cycle	54
Table 4.2. Electrified Vehicle Maximum Charging Power	55
Table 4.3. Vehicle Fleet Costs	68
Table 5.1. Charger Swapping Requirements for Each Case	73
Table 5.2. Recommendations to UW Transportation for Fleet Electrification.....	82

LIST OF ACRONYMS

AFLEET- Alternative Fuel Life-Cycle Environmental and Economic Transportation Tool
ECE- Electrical and Computer Engineering
EIA- Energy Information Administration
ENGINE- Engineering, Innovation, and Entrepreneurial
EPA- Environmental Protection Agency
EV- Electric vehicle
EVSE- Electric vehicle supply equipment
ICE- Internal combustion engine
MOVES- Motor Vehicle Emission Simulator
NREL- National Renewable Energy Laboratory
OCPP- Open Charge Point Protocol
PHEV- Plug in Hybrid Vehicle
SAM- System Advisor Model
SCL- Seattle City Light
SOC- State of charge
TCO- Total cost of ownership
UW- University of Washington

ACKNOWLEDGEMENTS

Thank you to all of the people who contributed to this project:

Professor Daniel Kirschen- *for advising this thesis project as well as the managed charging capstone and for providing support and guidance throughout the process.*

Professor Baosen Zhang- *for serving on my thesis defense committee and for your teaching contributions to my energy and power education.*

Professor Whittington- *for advising the managed charging capstone and introducing me to the transportation electrification plan.*

Lucie Hwang- *for advising the managed charging capstone and connecting the team with industry members.*

The managed charging ENGINE capstone team- *thank you to James Clough, Tran Quach, Carmen Twitchell, and Reese O'Craven for your dedication, motivation, and enthusiasm for this project even when faced with the challenges of the pandemic.*

Daniel Eden and UW Transportation- *for providing data and expertise to support this project and for your enthusiastic collaboration.*

Jeremy Park and UW Facilities- *for providing data and expertise to support this project and for guiding the UW capstone group with infrastructure research.*

UW Solar members- *for continuous efforts to put solar projects into action for support of electrification.*

Professor Ronald Lasser- *for encouraging me to pursue a thesis as a launchpad to my career.*

DEDICATION

I dedicate this thesis to my parents, my sister, and my close friends for your continuous support throughout the challenges of the past two years. You have all been there for me when I needed it most, enabling me to achieve my academic goals while enjoying the process!

INTRODUCTION

The transportation sector is responsible for about 28% of the United States' greenhouse gas emissions, making it the largest emitting sector in the country [1]. In an effort to reduce transportation emissions, companies, institutions, and governments have set goals for producing electric vehicles (EVs) and replacing conventional fleets with electric ones. The University of Washington (UW) is among those who have made commitments to reduce carbon emissions. It has consistently been recognized as a top performer in transportation sustainability according to the AASHE Sustainable Campus Index [2]. As stated in the University of Washington Sustainability Action Plan, UW aims to reduce greenhouse gas emissions by 45% by 2030.

One of the main action items to reach this target is to electrify the UW Transportation Services vehicle fleet [3]. Fleet electrification, however, requires substantial infrastructure and costs due to the collective energy and power requirements of all the vehicles. To ensure that UW can electrify the fleet and remain within budget and grid constraints, UW Transportation must consider charge management and charge scheduling strategies to optimize power, energy, and charger infrastructure. This study incorporates data from UW Transportation, UW Facilities, fleet vehicle users, and existing electrification planning to evaluate various electrification strategies and highlight the benefits and drawbacks of each.

1.1 THESIS OVERVIEW

Previous work exists which sets the groundwork for this thesis. Chapter 2 summarizes the results, methods, and conclusions from prior work to give context for the calculations and procedures described in Chapter 3. Chapter 4 is an analysis of the results of these calculations and procedures.

Finally, Chapter 5 concludes the document and includes recommendations and opportunities for future work.

The purpose of this thesis is to change the context of UW Transportation fleet electrification from a broad goal to a realistic, actionable process. This work provides several options for fleet electrification and the implications on energy, power, infrastructure, and cost for each option using data to support and quantify the results. In addition, results from a fleet vehicle user survey provide insight into the effects of fleet electrification on the end user and validate the assumptions made for calculations. As a result of this thesis, UW Transportation and other relevant constituents should be able to choose a charging scheme that best fits their needs as well as the needs of the university and the fleet vehicle users. To maintain status and efforts as a leader in sustainability, UW can carry out the recommendations and future work provided in the conclusion which will allow the university to continually apply innovations in the electrified transportation space and demonstrate the benefits of smart charging.

Chapter 2. PRIOR WORK

Several studies and projects have already been completed at the University of Washington regarding UW Transportation fleet electrification. UW Solar, a registered student organization and vertically integrated project at UW, is working with the Urban Infrastructure Lab and UW Transportation to implement solar canopies for charging. Additionally, UW Solar members have written a fleet electrification report for UW Transportation, which evaluates the existing fleet and infrastructure to make recommendations for electrification strategies.

During the 2020-2021 academic year, Seattle City Light (SCL) sponsored a UW Electrical and Computer Engineering, Innovation and Entrepreneurial (ENGINE) capstone project on the topic of managed electric vehicle charging. The purpose of the capstone project was to create a software tool that uses charge scheduling, fleet, and energy data to implement a managed charging algorithm which could interface with electric vehicle chargers.

As a member of UW Solar and the managed charging capstone team, I contributed to the existing transportation electrification plan as well as the managed charging project. These projects provided a foundation for the UW Transportation fleet electrification methods evaluated in this thesis.

2.1 UW SOLAR TRANSPORTATION ELECTRIFICATION REPORT

Members of UW Solar and the Urban Infrastructure lab developed the transportation electrification report during the 2019 to 2020 academic year. The objective of this report is to aid UW Transportation Services in the electrification of the fleet by providing information about the technology, incentives, and costs involved with the ten-year fleet electrification plan. In addition,

the authors evaluate vehicle replacement models using a multi-criteria analysis method. Also included in the study is results and analysis from a survey of UW fleet vehicle users, most of whom are participants in the UCAR ride sharing program. The report concludes with a financial case study comparing costs for a Honda Civic versus a Chevrolet Bolt based on the cost calculation methods introduced at the beginning of the report.

2.1.1 *UW Solar Transportation Electrification Report: Background*

UW Solar and the Urban Infrastructure Lab are collaborations between students and faculty to study and improve infrastructure to make a positive environmental impact [4]. According to the report, there are several additional benefits to and incentives for installing the infrastructure necessary for electrification. Electric vehicles require less maintenance than conventional gasoline-powered vehicles. Additionally, EV propulsion systems are more energy efficient than conventional internal combustion engines (ICEs). The state of Washington has instituted several bills for electrification, which include the Motor Vehicle Emissions Standards, Clean Energy Transformation Act, and Greenhouse Gas Emissions Limits. These bills collectively adopt California emissions standards, set a goal for Washington to become carbon neutral by 2030, and dictate that the state reduces greenhouse gas emissions by 45% before 2030 [5]. They also provide incentive for UW Transportation to reduce reliance on fossil-fuel powered vehicles in addition to the goals set forth by the Sustainability Action Plan for a 10% reduction in greenhouse gas emissions by 2030 by electrifying the fleet [3].

2.1.2 *UW Solar Transportation Electrification Report: EV Costs*

According to the Transportation Electrification Plan, the two main factors to consider for total cost of EV ownership are purchase costs on the fleet level and the total cost of ownership (TCO) on the

vehicle level. TCO includes fixed costs, operating costs, fuel use, and equivalent environmental costs for greenhouse gas emissions. EVs are less expensive than conventional vehicles over their lifetime since they do not require as much maintenance, do not have associated tailpipe emissions, and use electricity as a fuel source, which is less expensive and volatile than gasoline. The report uses Argonne National Laboratory's Alternative Fuel Life-Cycle Environmental and Economic Transportation Tool (AFLEET) to calculate total cost, petroleum use, and emissions for the life cycle of a vehicle or vehicle fleet [6]. To calculate the financial impact from tailpipe emissions, the Motor Vehicle Emission Simulator (MOVES) software from the Environmental Protection Agency (EPA) is used [7].

To demonstrate the cost benefits of EVs, the plan includes a cost comparison of a conventional 2020 Honda Civic with an all-electric 2020 Chevrolet Bolt. The total cost for each vehicle is broken down into several sections: carbon cost, cost of downtime, taxes and fees, insurance cost, maintenance and repair cost, fuel cost, and depreciation. In addition, the study assumes 10 year of ownership and a 2% US inflation rate. The study also assumes that 55% of the annual miles driven are for city driving. This is based on the EPA plug-in hybrid data and may not be an accurate assumption for the UW vehicle fleet specifically; however, it is probably good enough for the purposes of the example cost comparison [8].

During the first 6 years of the lifetime for each vehicle, the calculated annual cost of the Chevrolet Bolt EV is greater than that of the Honda Civic due to the greater initial purchase price of the Bolt. However, since the recurring costs of the Bolt are less than that of the Civic, the TCO for the Bolt after 10 years is cheaper, costing \$50,973 for its lifetime compared to \$56,934 for the Civic. Furthermore, the cost of emissions for the Bolt over the 10-year lifetime is one quarter the cost of emissions for the Civic [9]. For the purposes of this thesis, I will focus mainly on energy

and power implications for electrifying the UW Fleet. I have included a cost estimation; however, it is not as comprehensive as the cost estimation used in the Transportation Electrification Report and should be used to compare approximate costs for various electrification scenarios rather than taken as an exact calculation.

2.1.3 *UW Solar Transportation Electrification Report: Survey of Fleet Users*

UW Solar and Urban Infrastructure Lab members gathered 361 survey responses from people who use the UW Fleet vehicles. The majority of the respondents are UCAR users. The UCAR system is a short-term vehicle rental service offered by UW Fleet Services that is available for faculty, staff, and students [10]. From the survey, the authors were able to gain insight into the main concerns that users have about electric vehicles. The most common concerns are initial cost of EVs and concerns related to range anxiety. In the context of UW Transportation fleet electrification, these concerns could be a barrier to complete electrification since some fleet users may be uncomfortable using electric vehicles and may push back to having the vehicle that they commonly drive replaced with an electric vehicle. To gain further insight into UW Transportation fleet vehicle user behavior, I conducted an additional survey targeted at non-UCAR users which I will discuss later in this thesis report.

2.1.4 *UW Solar Transportation Electrification Report: Charging*

To meet complete fleet electrification needs, the fleet will need to be charged with a combination of alternating current Level 2 (AC L2) 240 V chargers and direct current Level 3 (DC L3) fast chargers. AC L2 chargers require less power and are less expensive to purchase and install than DC chargers. However, DC chargers have the benefit of being able to charge vehicles very quickly and provide charging to larger vehicles that require too much energy to be charged in a reasonable

amount of time using L2 chargers [11]. The report estimates that UW Transportation will need to install 715 AC L2 chargers and 7 DC L3 chargers for the fleet and an additional 161 AC L2 and 33 DC L3 chargers for public charging [9].

This estimation is far greater than the results from the capstone project and from this thesis analysis. The Transportation Electrification Plan assumes a one-to-one vehicle to charger ratio and likely includes vehicles located at other UW campuses or other UW-owned locations throughout Seattle. The capstone project and this thesis project present solutions to minimize charger infrastructure demands using charge management and charge scheduling. Additionally, both the capstone and this thesis do not consider public charging since the focus is to electrify the UW Transportation vehicle fleet rather than to provide charging locations for the general public. Future work can extend to public charging, especially to determine the financial benefits of leaving chargers available to the public when they are not scheduled to charge fleet vehicles, such as during the daytime. However, due to existing electricity grid constraints at UW and the additional demands that public charging will require, such a charging scheme may not be feasible without upgrading campus distribution grid infrastructure.

2.1.5 *UW Solar Transportation Electrification Report: Takeaways*

The UW Solar Transportation Electrification plan introduces important background information and considerations for determining a strategy for electrification of the fleet. Most importantly, it includes a detailed financial analysis that incorporates calculations from trusted models. The capstone group addressed some of the gaps in the Transportation Electrification Plan, including managed charging, using solar generation to meet increased demand, and providing recommendations to UW Transportation when planning for vehicle replacements and the supporting infrastructure.

2.2 MANAGED ELECTRIC VEHICLE CHARGING CAPSTONE PROJECT

The Managed Electric Vehicle Charging ECE ENGINE capstone project was a year-long project sponsored by Seattle City Light. The capstone student team members consisted of me (project manager), James Clough (technical design lead), Carmen Twitchell (finance manager), Tran Quach (engineering manager), and Reese O'Craven (finance manager). Professor Daniel Kirschen from the ECE department, Professor Jan Whittington from the Urban Infrastructure Lab and UW Solar, and Lucie Huang from Seattle City Light advised the project. The team also received guidance from Professor Payman Arabshahi, who teaches the capstone class, and Shruti Misra, a teaching assistant for the class. As part of Seattle City Light's partnership with the UW ECE department, SCL provided the requirements for the project. These requirements are as follows:

- Design of a charging solution for UW Transportation and the Recology vehicle fleets.
- Optimization of EV charging demand using solar generation and battery storage.
- Analysis of solar generation and cost of fleet charging for the Recology fleet.
- Modeling of solar arrays using software tools.
- Development of software to manage the vehicle fleet schedule and charging rate.
- Incorporation of a web interface that allows a user some control over fleet charging.

In this thesis report, I focus on summarizing the research, methods, analysis, and conclusions for the UW Transportation charging solution. For a more detailed overview of the capstone project, readers may refer to the ENGINE capstone website [12] or may directly reach out to me for the full capstone report.

2.2.1 *Managed Electric Vehicle Charging Capstone: Overview*

The main output of the capstone project is a software tool to assist with charging planning. In creating the software tool, the capstone team gathered and analyzed data from UW Transportation and UW facilities for inputs to the tool, tested the functionality with a hardware proof-of-concept, analyzed solar generation and battery storage as solutions to meet increased demand from electrification, and developed cost estimates for various configurations of charge management and infrastructure.

Charge management, in the context of the capstone project and this thesis project, is the act of controlling charging rates of electric vehicles. “Smart” EV chargers can operate at powers less than the maximum allowed charging power determined by the vehicle as a way to minimize power requirements. The purpose of charge management is to optimize costs by charging during times when electricity costs are low and to minimize infrastructure needs by reducing and scheduling energy demand.

The main inputs to the charge management algorithm are the current battery energy level of a vehicle, desired battery energy level, time available to charge, number of available chargers, and availability of energy from solar generation. In addition, the algorithm prioritizes charging during off-peak times or when solar generation is available.

2.2.2 *Managed Electric Vehicle Charging Capstone: System Specifications*

Table 2.1 shows the system specifications for the capstone project. The number of UW Transportation fleet vehicles is based on data from UW Transportation for the fleet composition as of January 2020. The capstone project assumes a fixed number of EV chargers based on calculations to minimize chargers. Additionally, the charger composition includes DC fast chargers, which can accommodate more vehicles than AC L2 chargers due to the higher power output. Finally, the off-grid battery capacity is calculated based on the solar generation.

Table 2.1 Capstone System Specifications

Parameter	Value	Tolerance	Units
Number of UW EV Fleet Vehicles	684	+/- 2%	vehicles
Number of UW EV Chargers	110	+/- 20%	chargers
Off-grid Battery Capacity	40.4	+/- 10%	kWh

2.2.3 *Managed Electric Vehicle Charging Capstone: Methods and Design*

UW Transportation Fleet Electrification Study

To create a plan for electrifying the UW Transportation vehicle fleet, the following procedure was used:

1. Gather data from UW Transportation.

To estimate power and energy needs of the fleet, the team received data from UW Transportation regarding the total miles driven, years in operation, make and model, and purpose of each vehicle in the fleet for 2020.

2. Calculate energy and power requirements for fleet vehicles.

From the existing data, the team calculated the average miles per day driven by each vehicle in the fleet and determined the appropriate EV replacement for each vehicle that could

serve the same purpose as the existing vehicle. From there, the energy required to charge each vehicle at the end of each day is calculated using the energy capacity of the replacement vehicle and miles driven per day.

3. Determine power requirements for the fleet.

The power requirements are calculated for each vehicle using the energy requirements and an estimate of the time available to charge. In an unmanaged charging scenario, the power per vehicle is equal to the maximum allowed charging power determined by the onboard charger of each vehicle. In a managed charging scenario, the power per vehicle is a function of time available to charge. For power-intensive vehicles, DC fast chargers are chosen for charging.

4. Generate an energy demand curve for the fleet schedule.

A sample schedule was manually created in an effort to optimize power, energy, and number of chargers. Charging is assumed to occur at night during the off-peak hours of 10am-6pm. Separate calculations are performed for the vehicles using AC L2 chargers and those using DC fast chargers.

5. Provide reasonable vehicle requirements for input into the software tool.

Based on the energy requirements, time available to charge, and power requirements calculated for each vehicle, reasonable values can be chosen to input into the software tool.

Managed Charging Software and Hardware

Figure 2.1 shows the system architecture for the managed electric vehicle software tool. The tool interfaces with the EV chargers using the Open Charge Point Protocol (OCPP), which is an industry standard for communicating between a charger and a central controlling system [13]. The

OCPP server, SteVe, is an open-sourced software developed by Aachen University that runs on a Raspberry Pi Linux machine. SteVe also has its own web interface [14]. In order to input data regarding the charge schedule, HTTP requests are sent to SteVe through the backend. To simulate an EV charger, the tool uses code from an open-source Arduino library. This is represented by the EVSE block in the diagram, which stands for electric vehicle supply equipment.

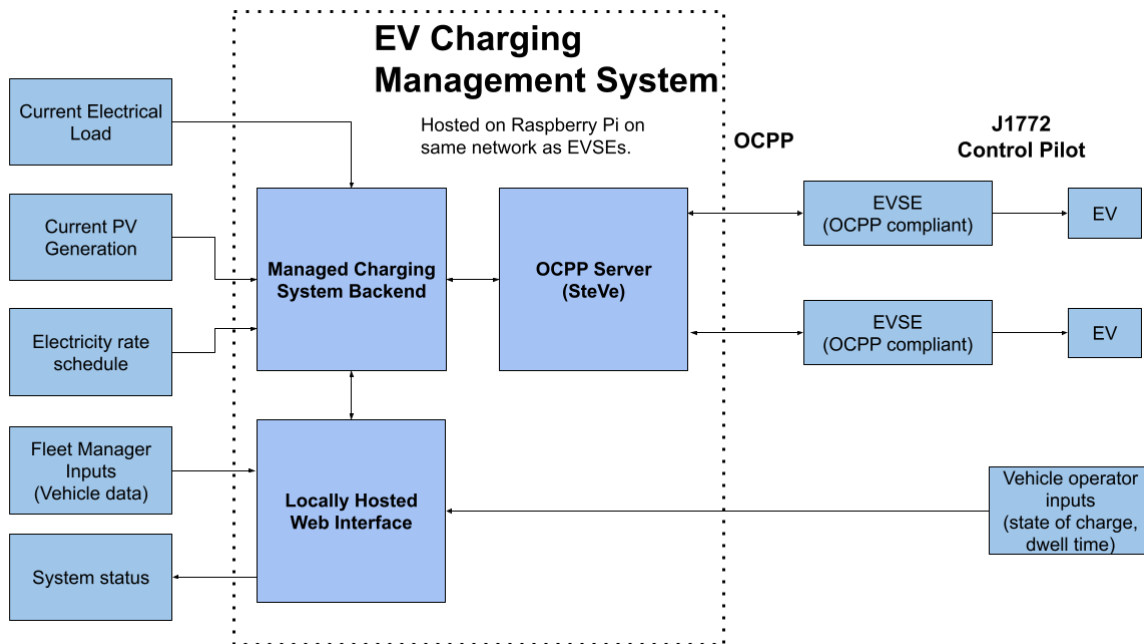

Figure 2.1. Software System Architecture

The charge management system takes several inputs. Data for the backend includes the power constraints of the vehicles, chargers, and the entire system; the time available to charge; energy requirements for each vehicle; times at which electricity rates are peak and off-peak; and the excess power generated from solar. As shown in Figure 2.2, the user can input charging time constraints, recurrency, and a minimum charging rate into SteVe to generate a charging profile. The user inputs vehicle data such as state of charge, battery capacity, and maximum charging power via the web interface.

Add Charging Profile

Details

Description: Charge Only 10pm to 6am

Stack Level (integer): 0

Charging Profile Purpose: TX_DEFAULT_PROFILE

Charging Profile Kind: RECURRING

Recurrency Kind: DAILY

Valid From:

Valid To:

Duration (in seconds):

Start Schedule: 2021-03-09 06:00

Charging Rate Unit: A

Min Charging Rate (decimal, multiple of 0.1):

Additional Note:

Schedule Periods

Start Period (in sec)	Power Limit (in amperes)	Number Phases	
0	48	1	Add
28800	0	if empty, 3 will be assumed	Delete

Add Back to Overview

Figure 2.2. SteVe Charging Profile

Electric vehicles operate by sending a pilot signal to the charger. The pilot signal is a 1kHz +/- 12V square wave that defines the state of an electric vehicle to determine whether it is connected to a charger and if it is actively charging or idle [15]. To simulate a pilot signal from an EV, the capstone team constructed a circuit with a 4-way switch to toggle between pilot signal types. Additionally, the team used simulated chargers from ESP8266 microcontrollers (as shown in Figure 2.3) as well as a network capable PowerCharge Platinum EV charger which UW Transportation supplied to the team for testing purposes [16].

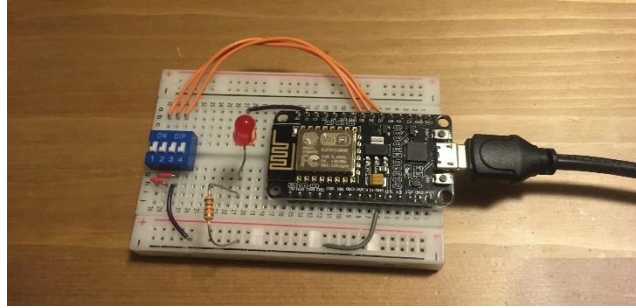

Figure 2.3. Simulated EV Charger

To test the hardware and software, the capstone team used the test setup as shown in Figure 2.4 and the following procedure:

1. Input historical load data and simulated solar generation data for meter values.
2. Establish communication between the EV charger and the SteVe OCPP server via a local Wi-Fi network.
3. Change the state of the simulated EV using the switches. This sends a status message from the charger to SteVe.
4. Set up a test charging profile on the SteVe server.
5. Send the charging profile to the charger.
6. Connect the simulated EV and start a transaction.
7. Verify that the charging transaction has been initiated by viewing the connector status page of the SteVe web interface.
8. Confirm that the state and power limit of the charger are correct by viewing the control pilot signal from the EV circuit with an oscilloscope.
9. Connect the PowerCharge charger to the system to verify functionality with a real charger in conjunction with simulated chargers.
10. View the outputted power schedule on SteVe.

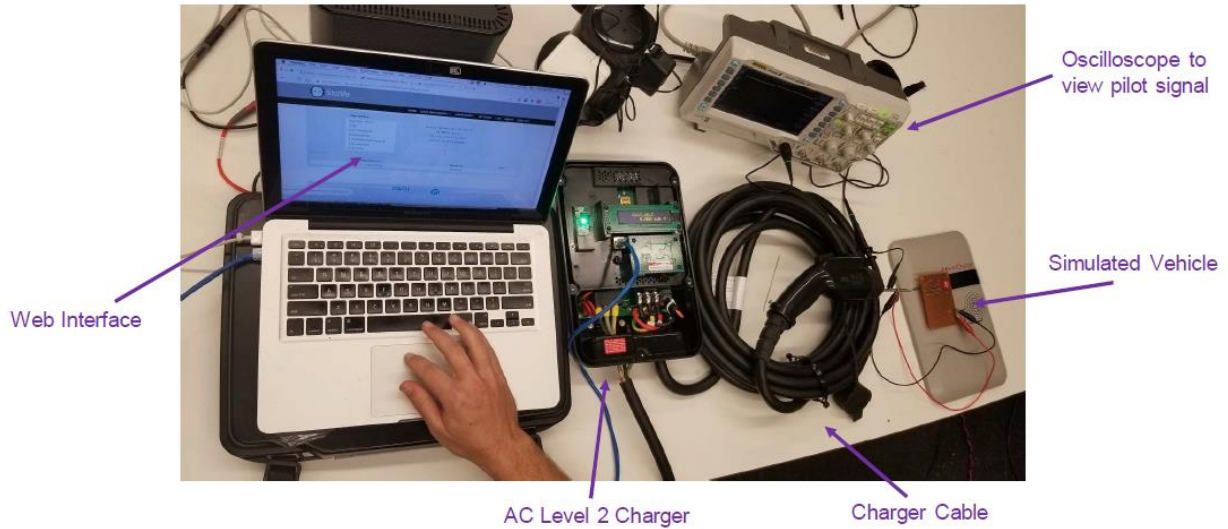

Figure 2.4. Capstone Test Setup

Solar and Charging Infrastructure

In partnership with UW Solar, the capstone team included a study of using solar generation to help meet the additional energy demand from fleet electrification. The design was constructed using Google's Project Sunroof [17], HelioScope [18], and the National Renewable Energy Laboratory (NREL) PVWatts Calculator [19]. These tools estimate solar energy production each day during different times of the year based on location, shading, and design factors such as tilt and available space for solar panels. Finally, the team used NREL's System Advisor Model (SAM) to create a table of solar generation for fifteen-minute intervals for an entire year. The energy data, power data, and generation table were then used for inputs to the software tool, inputs to the financial estimates, and feasibility study for the electrification plan.

Financial Estimates

To calculate financial estimates for various configurations of charging based on different management and scheduling schemes, the capstone team used the following procedure:

1. Calculate current costs for the UW transportation fleet.

These costs are based on fuel usage data from 2018 for the fleet, as well as fuel prices in 2020.

2. Calculate the cost of the proposed charging system.

The cost of installation, components, and labor was provided by Atom Power in their study of installing 120 chargers on the E1 and E18 parking lots. Added to that cost is the cost of electricity, which is calculated from Seattle City Light off-peak and peak rates. These costs are calculated for 4 cases: (1) managed charging with no solar generation, (2) managed charging with solar generation, (3) unmanaged charging with no solar generation, and (4) unmanaged charging with solar generation. Finally, cost projections for fuel and electricity are included to re-calculate costs over a ten-year period assuming an entirely electrified fleet each year.

3. Calculate cost of battery storage.

Using data from solar generation requirements, the capstone team calculated the battery storage capacity and cost required to take the system off-grid so it would no longer rely on electricity from the grid. This adds an additional upfront cost but eliminates recurring electricity costs.

2.2.4 Managed Electric Vehicle Charging Capstone: Analysis and Results

UW Transportation Fleet Electrification Study

The vehicle composition for a 100% electrified UW Transportation fleet is shown in Table 2.2 below. Some of the vehicles, namely the large trucks and buses, are only compatible with high

power AC chargers or with DC chargers. Therefore, they are divided into a different category than AC L2 chargers since they require much more expensive infrastructure and much more power.

Table 2.2. Electric Replacement Vehicles

Vehicle Type	Number of Vehicles	Charger Type
2022 Chevy Bolt EUV	100	AC L2
Chevy Bolt	105	AC L2
Ford 2022 e-transit	221	AC L2
Ford F150 EV	160	AC L2
Nissan Leaf	55	AC L2
Rivian R1T	7	AC L2
TOTAL AC L2	648	
BYD Trucks	24	AC 40 kW
MT50e	5	DC
Proterra	3	DC
Gillig battery electric	4	DC
TOTAL HIGH POWER	36	
TOTAL VEHICLES	684	

The AC L2 compatible vehicles collectively require 128 MWh to charge and the DC fast charger compatible vehicles collectively require 1.8 GWh to charge according to the calculations from the capstone. These calculations were performed under the following assumptions:

- Vehicles are charged to 90% of their capacity and discharged to no less than 20% of their capacity to minimize battery degradation.
- Vehicles are only used on weekdays and charged on weekdays or weeknights.
- There are 120 chargers available for the entire fleet.
- The charge rate is determined by the maximum power allowed by the vehicle internal charger hardware. This means that charging is unmanaged.

- Vehicles are charged on a 6-day cycle, so that over the course of the 6 days, every vehicle in the fleet has been completely discharged and charged again. Each vehicle is charged once every 6 days.
- Charging occurs at night.
- There are no minimum charge rates.
- Chargers switch on automatically or an attendant can plug and unplug vehicles from chargers. An attendant can move vehicles to cycle them through the chargers.
- Energy requirements are calculated as an average for each vehicle type.

After determining the energy requirements for each vehicle type, the number of vehicles for each type was spread out evenly over the 6-day cycle in order to spread energy requirements evenly per day. The results for AC L2 charging schedule are shown in Table 2.3. Table 2.4 shows the results for the DC charging schedule.

Table 2.3. AC L2 Compatible Vehicles Charging Schedule

Day	Number of 2022 Chevy Bolt EUV	Number of Chevy Bolts	Number of e-transit	Number of F150 EV	Number of Nissan Leaf	Number of Rivian	Total Vehicles
1	16	17	37	26	10	0	106
2	16	17	38	26	9	0	106
3	17	17	38	27	9	0	108
4	17	18	36	27	9	1	108
5	17	18	36	27	9	3	110
6	17	18	36	27	9	3	110
TOTAL	100	105	221	160	55	7	648

Table 2.4. DC Fast Charging Compatible Vehicles Charging Schedule

Day	Number of BYD	Number of MT50e	Number of Proterra	Number of Gillig
1	5	2	0	0
2	5	2	0	0
3	5	1	0	1
4	3	0	1	1
5	3	0	1	1
6	3	0	1	1
TOTAL	24	5	3	4

As a result of the charge schedule and the energy requirements, the power requirements for the 6-day cycle are shown in Figure 2.5 below.

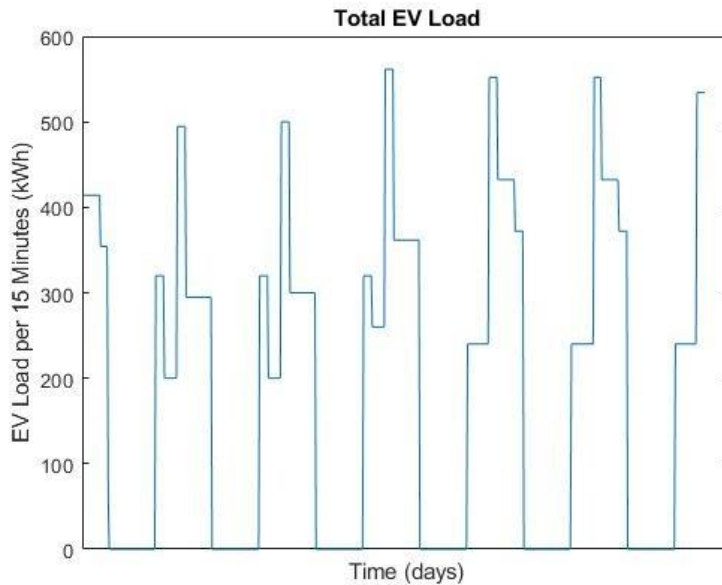

Figure 2.5. Power Schedule for the UW Transportation Electrified Fleet

Managed Charging Software and Hardware

The software and hardware setup is an effective proof-of-concept to demonstrate the components of a managed charging system. The capstone team was able to simulate interaction between

chargers, electric vehicles, and a networked charger control system as it reacts to inputs in order to generate an output charging schedule as shown in Figure 2.6.

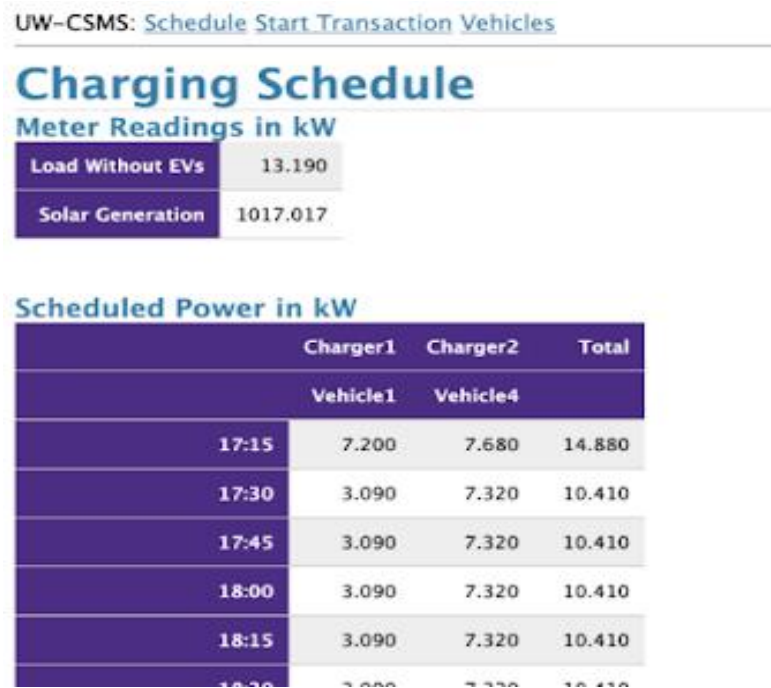

Figure 2.6. Charging Schedule from Software Tool.

Solar and Charging Infrastructure

The capstone team completed a solar design on HelioScope in collaboration with UW Solar for a solar photovoltaic canopy which covers the E1 and E18 parking lots on the UW campus. The full buildout of the solar canopy is shown in Figure 2.7, and is rated at 6.41 MW, producing 7.3 TWh/yr of power [20]. Figure 2.8 shows the power produced by the solar canopy for a typical day in each season. In the summer, generation is highest at almost 3.5 MW. In the winter, generation is lowest at just above 1 MW.



Figure 2.7. E1 and E18 Solar Canopy Design

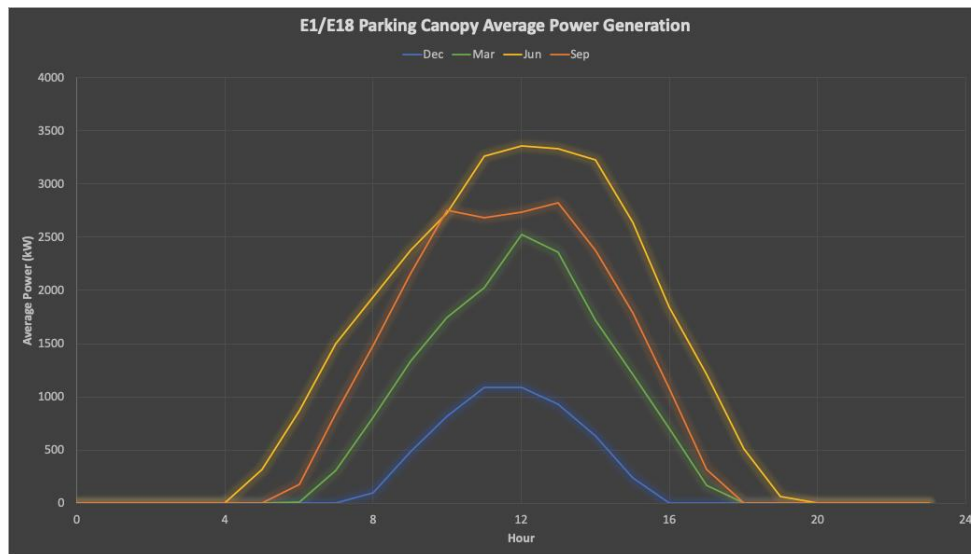

Figure 2.8. Average Power Generation from the E1/E18 Solar Canopy

Additionally, the capstone team partnered with Atom Power, a company that designs managed chargers as well as electrical panels for the chargers, to prepare a design for the installation of 120 chargers in the E1 parking lot. The preliminary design is shown in Figure 2.9 below. After meeting with Jeremy Park from UW Facilities and Joe Martek from Seattle City

Light, the capstone team determined the appropriate infrastructure required to support the chargers. The E1 and E18 lots connect to the UW distribution system. There is a 13.8 kV distribution line near the southeast corner of the lot which can be accessed to deliver power to the chargers. Transformers and inverters are placed near the vault to drop the voltage down to 240 V for AC L2 charging. From there, lines running from the main breaker of the Atom Panel can be run above ground to the chargers using sufficient conduit for protection.



Figure 2.9. Atom Power EVSE Design

Financial Estimate

The total cost of fuel for the conventional fleet during 2020 is about \$862,000. The capstone team found this cost based on the 2018 fuel consumption data, which was then weighted to reflect the decrease in the number of fleet vehicles from 2018 to 2020. Using the price of fuel at the start of 2020, the team calculated the cost for unleaded, diesel, and E-85 fuel.

Next, the team calculated the cost of charging infrastructure using the materials and cost estimate that Atom Power provided for 120 electrified parking spaces, as shown in Table 2.5 below.

Table 2.5. Electric Vehicle Charging Infrastructure and Costs for 120 Parking Spaces

Electric Vehicle System Equipment Design Allowance		
Power Conductor (L1/L2)	6 AWG	50400 ft
Ground Conductor (GND)	10 AWG	13200 ft
Pilot Conductor (Twisted)	16 AWG	26400 ft
Conduit Size	1" EMT	12000 ft
Atom Power EVSE Cost	\$215,000.00	
Material Cost	\$61,670.67	
Labor Cost	\$323,130.80	
Total EVSE System Design Allowance	\$599,801.47	

To calculate the electricity costs for electrifying the fleet, the energy requirements for the fleet during off-peak and peak hours are multiplied by the energy costs for the fleet using Seattle City Light’s rate structure for high demand businesses [21]. For cases that include solar, the solar generation energy is subtracted from the electric vehicle load energy, sometimes resulting in a negative cost reflecting excess solar energy being sold back to the grid. The managed charging system which includes solar generation is the cheapest option, as shown in Table 2.6. The 2nd cheapest option also includes solar generation but is for an unmanaged system.

Table 2.6. Year 1 Total Cost for an Electrified Fleet

	System Components, Installation and Labor Cost	Cost of Electricity	Total
Proposed managed system, no solar generation	\$273,600.00	\$139,719.09	\$413,319.09
Proposed managed system, solar generation	\$599,801.47	-\$396,309.66	\$203,491.81
Unmanaged system, no solar generation	\$273,600.00	\$150,324.11	\$423,924.11
Unmanaged system, solar generation	\$599,801.47	-\$385,704.65	\$214,096.82

In addition, the team calculated the cost to use battery storage for the solar generation, which takes the system off-grid and eliminates electricity costs. The cost for the battery system is about \$1M, and the team assumed this is a fixed, one-time cost. Including cost analysis with and without battery storage, the least expensive option is managed charging with solar generation and no battery storage, as shown in Figure 2.10 below. Additionally, less than two years after complete electrification, all of the combinations involving electrifying the fleet will be cheaper than the cost of the current system.

Break Even Analysis

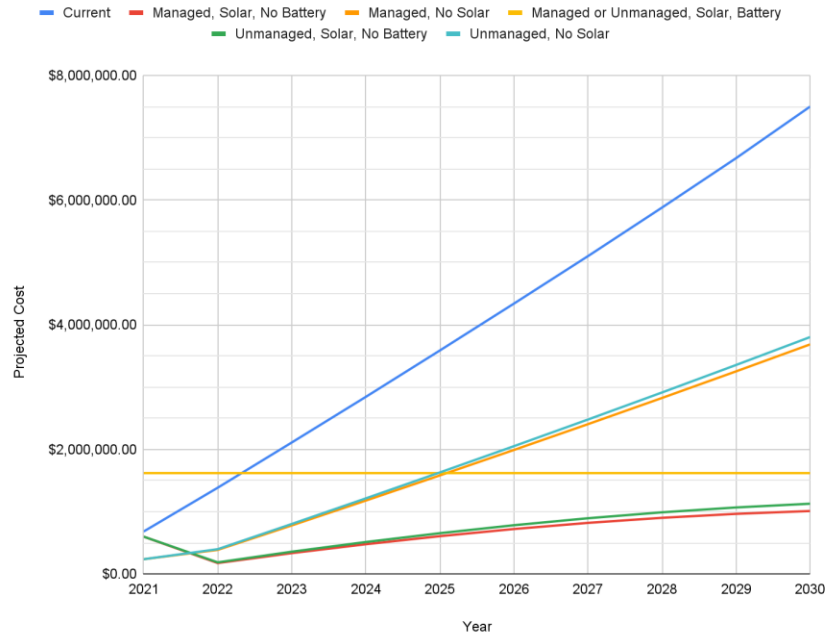

Figure 2.10. Capstone Break-even Analysis for UW Transportation Electrification

2.2.5 *Managed Electric Vehicle Charging Capstone: Conclusion*

According to the results of the capstone project, there are several options for fleet electrification that are feasible from a cost and infrastructure standpoint. Using DC fast chargers for vehicles that have large energy requirements would allow UW Transportation to electrify the fleet with as little as 120 chargers on a 6-day charging cycle. Additionally, installing solar panels on the E1 and E18 parking lots would offset the energy demand from electrification of the fleet.

Although the capstone team developed a software tool for managed charging, realistically if UW Transportation implements managed charging, they will use software developed by a professional corporation. Regardless, the capstone team gives recommendations for what features such a software tool should include. These features are:

- Ability to adjust the power and energy requirements for each charger based on total load on the grid.
- Solar generation as an input to the system so that when solar power is being generated, chargers can take advantage of it.
- An input for energy requirements of the fleet vehicles and the desired charging schedule constraints.
- Use of electricity costs at different times to prioritize off-peak charging.

Figure 2.11 shows a general procedure for electrification of the fleet, which the capstone team recommends as a result of the project.

1	Research the fleet's composition and operational requirements
2	Identify EVs with similar capabilities
3	Calculate the vehicles' energy requirements based on current usage
4	Determine the number and type of EV chargers needed to meet these energy requirements during the time the vehicles are parked
5	Create a charging schedule using charge management software
6	Determine the charging infrastructure needed for each fleet and incorporate solar generation in the electrical design

Figure 2.11. Recommended Procedure for Fleet Electrification

While determining a plan for fleet electrification, the capstone group made several assumptions. First, they use averages for all vehicles of the same type to determine energy and power requirements. This method is good enough for estimations but removes maximum and

minimum requirements from individual vehicles. In this thesis report, I expand upon the capstone analysis by considering vehicles individually rather than as an average.

Another assumption is that UW can install the full buildout of the E1/E18 solar canopy prior to implementing the ten-year vehicle replacement plan as a way to account for extra load from electric vehicle charging. Currently, UW is working on a plan for a partial buildout of the solar canopy, but it will likely not be complete until several years into the ten-year replacement plan. Therefore, it is safest to assume that there is no solar generation to accommodate extra load. Solar generation is usually decoupled from vehicle charging since vehicles often charge at night when they are not in use and solar generation occurs during the day. Using a battery for storage would shift the solar generation to accommodate charging at the time that vehicles require it, however the results of the financial analysis show that battery storage is a more expensive solution. If possible, UW Transportation should find a way to schedule and manage charging so that the load fits within grid constraints without requiring solar power and battery storage. In this thesis report, I analyze managed and scheduled charging without solar generation and provide cost estimates for various scenarios.

Chapter 3. METHODS AND PROCEDURE

The primary methods for gathering data for use in energy, power, and cost calculations involved collaborating with UW employees as well as conducting a survey. In the capstone project, the team mainly used Excel and Google Forms spreadsheets to perform calculations. For this thesis project, I used MATLAB to streamline the calculation process and output tables and graphs to visualize the results.

3.1 DATA COLLECTION METHODS

The data used in this project comes from several sources. UW Solar has a long-standing partnership with UW Transportation and UW Facilities, and therefore has a significant amount of data regarding the UW Transportation vehicle fleet as well as the electricity grid load. From the existing UW Transportation electrification study, UW Solar has a dataset on total fuel usage, which was used in the capstone project and is used for this thesis. Additionally, UW Solar uses data about total campus load to assess the need for additional solar generation on campus.

For the capstone project, the team worked closely with Daniel (Danny) Eden, the Fleet Services Manager at UW Transportation. I have continued to work with Danny while extending the capstone project to this thesis. Danny is in charge of purchasing fleet vehicles and managing the UCAR system. He provided valuable data for this project regarding fleet vehicle locations, charger locations, and the ten-year replacement schedule that UW Transportation will follow to electrify the fleet. Additionally, UW Transportation provided vehicle composition data which I use as a starting point for all calculations.

This data set includes the following information about every vehicle in the UW Transportation fleet:

- Equipment ID used to identify the vehicle
- Date purchased
- Total miles accumulated since purchase date
- Designation (UCAR, fleet, department)
- Make and model
- Purpose

I also worked with Danny to develop and distribute a survey for fleet vehicle users that helps characterize vehicle usage. This survey specifically targets fleet vehicle users rather than UCAR users since the UW Solar team already performed a survey which mainly targets UCAR users.

Additionally, for the purposes of the capstone and for this project, Jeremy Park, the Electrical Utilities and Power Systems Manager at UW Facilities, provided data regarding campus infrastructure. This data about the overall campus load, feeder capacity at charging locations, and available power for the UW distribution system is crucial in determining whether the existing UW infrastructure can support various charging configurations for an entirely electrified fleet.

Any additional data used in the thesis project I found via online research through reliable internet sources or through the UW library database system.

3.2 VEHICLE AND CHARGER VISUALIZATION METHODS

The current vehicle fleet is distributed among over 75 parking lots at the UW Seattle campus [22]. Twelve of these parking lots currently have chargers on site. Since these sites already support charging infrastructure, it is most convenient to expand the number of chargers at these twelve

sites and only add charging infrastructure to other parking lots if necessary. To show the increase in electric vehicles at each parking lot location each year, I produced a click-through bubble map in MATLAB. The bubble map provides a simple way to identify locations where electric vehicles will be parked and therefore where charging infrastructure will be placed during each year of the 10-year replacement plan. Additionally, it shows which lots will have the greatest number of electric vehicles and likely require the most charging infrastructure.

3.3 ENERGY, POWER, AND COST CALCULATION PROCEDURE

To calculate the energy, power, and cost estimates for a ten-year fleet electrification plan, I consider seven different charging scenarios which use different charge management and charge scheduling strategies. For example, when charging is scheduled but unmanaged, all of the vehicles are charged at a fixed, maximum power on certain days according to a rotating schedule. The number of chargers needed in each location each year is based on the energy requirements of the fleet. The cost is a function of the energy requirements and of the number of chargers required. Combined, the energy, power, and number of chargers required determine the infrastructure and financial requirements for fleet electrification. UW Transportation can use this analysis to choose the charging scheme that best fits their needs and constraints.

3.3.1 *Initial Calculations*

UW Transportation provided input data regarding the equipment ID, purchase year, make, model, accumulated mileage since the purchase year, and fuel type for each vehicle in the UW Transportation fleet. This data is for all vehicles in the fleet which are distributed across the UW Seattle, UW Bothell, and UW Tacoma campuses and includes vehicles parked in other sites such as near medical center locations in downtown Seattle or at Friday Harbor Labs on San Juan Island.

For the purposes of this thesis, I analyze only the vehicles that are regularly parked at the UW Seattle campus in the University District. Therefore, prior to reading in the data from an Excel spreadsheet as a table, I delete data from vehicles parked at other sites.

Next, I calculate the average daily mileage, which is an input for the state of charge (SOC) calculation used for energy, power, and charger calculations. The average daily mileage is found using Equation 3.1 below.

$$\text{Daily mileage} = \frac{(2020.5 - \text{purchase year})}{\text{accumulated miles} \times 365 \times \frac{5}{7}} \quad (3.1)$$

The accumulated miles variable in the denominator is multiplied by (5/7) under the assumption that vehicles are usually used only on weekdays. Additionally, this calculation assumes that vehicles are used every weekday.

Then, I add data to the table based on the original vehicle make and model. UW Transportation provided a replacement schedule for each vehicle in the fleet. All vehicles of the same make and model are replaced with an electric or plug in hybrid vehicle (PHEV) of one make and model. For example, every Ford Focus is replaced with a Chevrolet Bolt. I populate new columns for the replacement vehicle, total battery energy capacity for the replacement vehicle, range of the replacement vehicle, replacement vehicle purchase price, and original vehicle purchase price. Therefore, each row in the table corresponds to one fleet vehicle and contains data pertaining to the electric vehicle that will replace it.

Using catastrophic insurance data that contains information about where each vehicle in the fleet is currently parked, I assign every replacement vehicle to one of the twelve parking lots that contains charging infrastructure. The replacement vehicles will be parked in the lot closest to the parking lot that the original vehicles were parked in. In many cases, the original vehicle and its

replacement can be parked in the same lot. I then add the parking lot data into the table as a new column.

3.3.2 *Energy Calculation Procedure*

The energy requirements of the electrified fleet are calculated using the following procedure:

1. Calculate the SOC of each vehicle at the end of one day of driving. The SOC is a measure of how much battery energy capacity is left. Vehicles are typically charged once the SOC reaches 20% and terminate charging once the SOC reaches 90%. This is because fully charging or discharging an electric vehicle battery causes the battery to degrade faster, reducing its usable lifetime [23]. The SOC calculation in Equation 3.2 below assumes that battery percentage stays within 20-90% and is expressed as a percentage.

$$SOC = 70 - \frac{\text{daily mileage}}{\text{range on full charge}} \times 100 \quad (3.2)$$

2. Calculate how many consecutive days each vehicle can be used before requiring a charge according to Equation 3.3, rounded down to the nearest integer so that if a vehicle still has charge left but not enough to support the mileage for the next day, it will be charged. Equation 3.3 shows the days between charging, so zero days between charging corresponds to a vehicle being charged every day, whereas 1 day between charging corresponds to a vehicle being charged every 2nd day.

$$\text{days between charging} = \frac{SOC}{70 - SOC} \quad (3.3)$$

To simplify the charging process, in many cases I assume vehicles are charged on a 6-day cycle. The vehicles with the least SOC left at the end of one day are charged every day. Those with the most SOC left at the end of one day are charged every third day, and those with SOC values in the middle of the range are charged every second day. This grouping is found using an adjusted calculation for the days between charging.

3. Find the energy needed to charge each vehicle after the calculated number of days between charging from above. This is a function of the SOC decrease after the specified days of use, which is calculated as a percentage according to Equation 3.4.

$$SOC \text{ used prior to charging} = (70 - SOC) \times (\text{days between charging} + 1) \quad (3.4)$$

The energy needed to charge the vehicle is measured in kilowatt-hours (kWh) and is calculated using Equation 3.5 below.

$$\text{energy to charge} = .01 \times SOC \text{ used prior to charging} \times \text{energy capacity} \quad (3.5)$$

4. Based on the charge schedule for a given scenario, sum the energy required to charge for all of the vehicles that are charging for each day of the cycle. For example, if 100 vehicles are charging on day 1 of the charging cycle, and each vehicle requires a certain amount of energy to charge on that day according to the calculation in Equation 3.5, then the total energy required to charge the fleet on day 1 is the sum of the energy to charge each of the 100 vehicles. After separately computing total energy for each day of the cycle, find the

maximum energy required on any given day of the cycle. This represents the maximum daily energy requirement for the fleet.

3.3.3 *Power Calculation Procedure*

Power is related to energy as a function of time (measured in seconds) and is measured in kilowatts (kW), as shown in Equation 3.6. For managed charging, to minimize power requirements, vehicles must charge for as long as possible. Assuming vehicles are charging only during the hours in which SCL energy rates are off-peak, the maximum time available to charge is 8 hours. However, some vehicles are used frequently or have large energy capacities and cannot be fully charged within 8 hours even when charging at maximum power. The power requirements for those vehicles are therefore set to the maximum charging power for that make and model, and the time to charge is calculated from the maximum power and the energy to charge. Time to charge is an input for charger and cost calculations.

$$\text{power to charge} = \frac{\text{energy to charge}}{\text{time available to charge}} \quad (3.6)$$

For the scenarios using unmanaged charging, I assume that all of the vehicles are charging at their maximum power. Electric vehicles have an internal maximum power that they can accept from a charger. Maximum power that an EV can accept varies with the make and model of the vehicle.

Since power requirements vary with individual vehicle energy requirements in the case of managed charging and with vehicle make and model in the case of unmanaged charging, the calculation for maximum power drawn per day depends on which vehicles are charging on a given day. To find the maximum power required on any given day of a charging cycle, one must sum

the power required by each of the vehicles charged on each day and then use the largest power value as an upper limit for that scenario.

It is also useful to visualize the demand curve for power once the electrified fleet load is added. Based on the duration of charging, day of charging, and rate of charging, the hourly power requirements of the electrified fleet are the sum of the power requirements at any given hour for each vehicle in the fleet. UW Facilities provided total campus load data for the 202-2021 academic year. To visualize the case in which the UW distribution grid would be most constrained in each charging scenario, the electrified fleet hourly power is added to the total campus load for the most power-intensive day represented by the data.

3.3.4 Cost Calculation Procedure

The total cost associated with fleet electrification is based on initial investment costs as well as recurring costs. This report also considers costs associated with the current fleet as a comparison to demonstrate total costs over time. Table 3.1 summarizes the initial and recurring costs for electric and conventional vehicles.

Table 3.1 Fixed and Recurring Vehicle Costs

Vehicle Type	Fixed Costs	Recurring Costs
EV	EV purchase price Charger installation and equipment	EV maintenance Electricity for charging
ICE	ICE purchase price	ICE maintenance Fuel

The cost comparison considers the fleet after year 10 of the electrification plan so that the following assumptions hold:

- All vehicles in the fleet that can reasonably be replaced with an electric vehicle have been replaced.

- The total cost of purchasing all of the vehicles in the fleet is the sum of the cost to purchase the replacements each year over the ten-year electrification period.
- If the vehicles were not replaced with electric vehicles, each vehicle would be replaced with the exact same make and model (with the model year associated with the year of replacement) ten years after the initial purchase date. The total cost of purchasing all the vehicles in the fleet would be the sum of the cost to purchase the ICE replacements each year over the ten-year period. Even if an original fleet vehicle is electric, plug-in hybrid, or hybrid, the same assumptions would hold.
- Maintenance costs are \$.012/mi for electric vehicles and \$.028/mi for internal combustion engine vehicles and are adjusted each year based on a 1.7% change each month, then adjusted to present value based on a 3.5% discount rate [24]. Equation 3.7 is used to calculate present value, where the discount rate is expressed as a decimal. The variable k represents the year that the present value is calculated for, and the variable b represents the base year, which in this case is 2032.

$$present\ value = unadjusted\ value \left(\frac{1}{1+discount\ rate} \right)^{k-b} \quad (3.7)$$

- The total cost of charger installation and equipment is the sum of the cost to install and buy charger equipment each year over the ten-year electrification period.

The cost of the charger equipment and installation is directly related to the number of chargers installed each year. Maintenance costs are a function of the total number of vehicles in

the fleet and average number of miles driven each year. Fuel and electricity costs, however, require a more in-depth calculation.

Electricity costs depend on whether charging occurs during peak or off-peak pricing. Seattle City Light’s rate structure for the University of Washington is \$.0882 per kWh peak and \$.0575 per kWh off peak [21]. Note that Sunday morning after 6am would be considered off-peak, which only affects the weekend charging scenario. However, since very little energy is consumed by vehicles during that time, to simplify the calculation, Sunday is treated as having the same rate structure as other days of the week. Since UW is in the large business category for the SCL rate structure, additional energy requirements from charging will not affect the rate structure pricing for UW because it is in the most expensive category already. For each scenario, I separately sum the amount of energy used for charging during off-peak hours and for peak hours, where energy is an average energy per day found by summing the energy used over the entire cycle and dividing by the number of days in the cycle. Fuel costs for ICE vehicles are based on the gallons of fuel used in 2018 to power the entire fleet as shown in Table 3.2 below.

Table 3.2. Fuel Usage for the 2018 Fleet

Fuel (Jan 2018 to Dec 2018)	UW Fuel Island	Outside Fuel Charges - WEX	Total (Gallons)
Unleaded	123,515	71,269	194,784
Diesel (B20 Blend)	42,500	4,299	46,799
E-85	49,800	36	49,836

Each year, the price of fuel and electricity changes according to the percent increase as calculated by the Energy Information Administration (EIA) data dashboard [25]. Therefore, the total cost of ownership each year for the fleet is the sum of:

- (a) The cost to invest in chargers and vehicles.
- (b) The cost of maintenance for the current and all previous years since total electrification in 2032, which changes per mile each year and is adjusted to present value based on a 3.5% discount rate [24].
- (c) The cost of fuel (gas or electricity) for the current and all previous years since total electrification in 2032, which changes per unit of fuel each year based on predicted fuel cost increases. It is also adjusted to present value based on a 3.5% discount rate [24].

Chapter 4. ANALYSIS AND RESULTS

Following the calculations and procedures from above, I analyze seven different charging scenarios and complete a cost analysis for each. Each scenario uses a different combination of managed, unmanaged, scheduled, or unscheduled charging so that at the end of the defined charging cycle, the entire fleet of electric or plug-in hybrid vehicles is charged. The vehicle locations and number of vehicles used in the charging scenarios are based on data from UW Transportation, which helps give an estimate of the fleet makeup for each year of the ten-year electrification plan. Additionally, the results of the vehicle usage survey validate the assumptions regarding vehicle usage and uncover possible edge cases that could be evaluated in future work.

4.1 VEHICLE TRENDS

4.1.1 *Fleet Vehicle Composition*

The total number of vehicles in the UW Transportation fleet was between 649 and 720 vehicles each year from 2012 to 2021, as shown in Figure 4.1. According to the UW Transportation vehicle replacement plan, there should be about 635 vehicles in the fleet located at the Seattle campus in the University District each year from 2022 to 2032. 606 of these vehicles will be replaced by the end of the ten-year replacement plan, and 538 of the vehicles will be replaced by plug-in hybrid or electric vehicles by the end of the plan. The vehicles that are not replaced are either retired or were recently purchased and have a longer replacement cycle than the standard cycle of ten years.

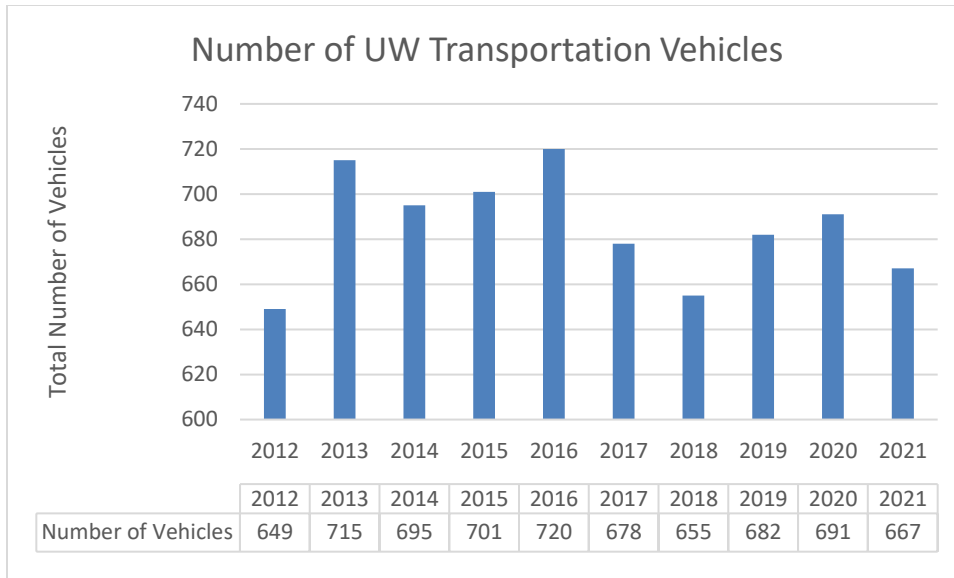

Figure 4.1. Number of UW Transportation Vehicles from 2012 to 2021

Of the vehicles located on the UW Seattle campus, some of them are replaced with conventional or hybrid vehicles rather than an electric or plug-in hybrid vehicle, meaning that after the ten-year plan, about 17% of the vehicles are not electrified. This is shown in Figure 4.2. UW Transportation presents the following reasons for replacing a vehicle with an ICE or hybrid:

- Lack of suitable EV or PHEV replacement for the vehicle type.
- Vehicle is used for off-road research in places without EV charging infrastructure.
- Client requested a replacement for the same make and model as the original vehicle.

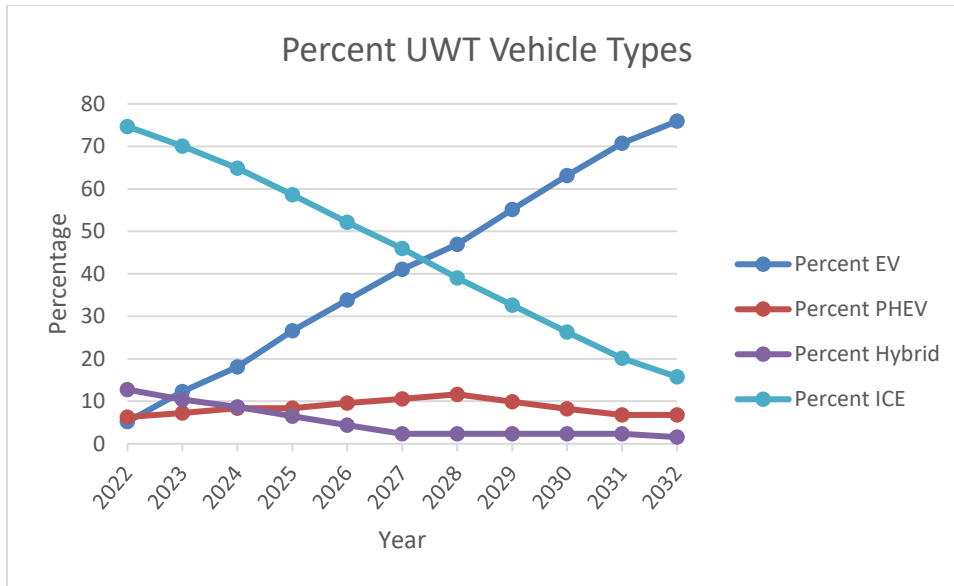

Figure 4.2. Percentage of each Vehicle Type each Year

Nevertheless, most vehicles can be replaced with EVs or PHEVs. In 2022, only 5.2% of the fleet vehicles are electric and 6.3% are plug-in hybrid. 12.76% are hybrid and the remainder are ICE vehicles. As EVs replace ICES, the percent of EVs increases and the percent of ICES decreases until 75.91% of the fleet is electric and 15.75% is conventional. The percentage of hybrid vehicles decreases to 1.57% in 2032 since the hybrids are replaced with EVs. However, since PHEVs are often replaced with the same make and model rather than with an electric vehicle, the percentage of PHEVs stays relatively the same so that 6.77% of the fleet vehicles are PHEV by 2032. Although the fleet will not be fully electrified by 2032, UW Transportation plans to make significant progress towards electrification within the next ten years.

4.1.2 Fleet Vehicle Locations

UW Transportation currently parks EVs or PHEVs at parking spots with chargers. In 2022, the number of chargers at the UW Seattle campus outnumbers the number of EVs and PHEVs. There

are 102 chargers distributed among 13 parking lots, whereas there are only 73 vehicles requiring charging. Of the parking lots with chargers, 12 of the parking lots contain fleet vehicles and one parking lot is dedicated to public charging.

Figure 4.3 shows the distribution of electrified vehicles (EV and PHEV) among the 12 parking lots that contain fleet chargers in 2022. The Central Plaza Garage (C1), S1 lot and Plant/Fleet Services lot near the Burke Gilman trail (N26) have the most electrified vehicles parked at them, which is indicated by the relatively larger bubbles compared to those at other lot locations. According to UW Transportation, the easiest way to add more chargers would be to expand the already existing charging infrastructure. As vehicles are replaced with EVs or PHEVs, they are moved to the charging parking lot closest to their original parking location. By the end of the ten-year electrification plan, 538 vehicles are electrified and distributed among the twelve parking lots for charging. The result, as shown in Figure 4.4, is that 239 vehicles are located in the N26 lot, with the S1 and C23 lots having the second and third most vehicles, accordingly.



Figure 4.3. UW Transportation Vehicle Locations 2022



Figure 4.4. UW Transportation Vehicle Locations 2032

It is important to note that in some cases, the number of vehicles is not the same as the number of chargers required at that location. As I will explain in Section 4.2, charge management and charge scheduling can reduce the number of chargers needed per vehicle. Furthermore, UW Transportation plans to have an attendant move vehicles in and out of charging parking spots and plug in and unplug chargers according to the charging schedule. For that reason, it is most convenient to have all of the vehicles that will be using the same charger parked in the same lot. However, if there are physically not enough parking spots in a lot to accommodate all of those vehicles, then UW Transportation will have to consider parking vehicles in other lots on days that they do not have to charge or adding charging infrastructure to a nearby parking lot. For example, the N26 lot probably cannot accommodate all 239 vehicles, so some of those vehicles could instead be housed and charged in the nearby E2 lot, as shown in the Google Maps image in Figure 4.5 below. Based on visualizing the N26 and E2 parking lots on Google Maps, N26 can likely fit about

100 vehicle and E2 can likely fit about 150 vehicles. The S1 parking garage has the 2nd highest population of vehicles but is a large garage and will be able to accommodate them all. One other parking lot which may have space constraints is the C23 lot. The analysis in this thesis results in at most 70 chargers being placed at C23, but from Google Maps visualization, this lot probably can only accommodate half of those chargers. However, it is near the large E2 and E18 parking lots where vehicles could instead be parked.

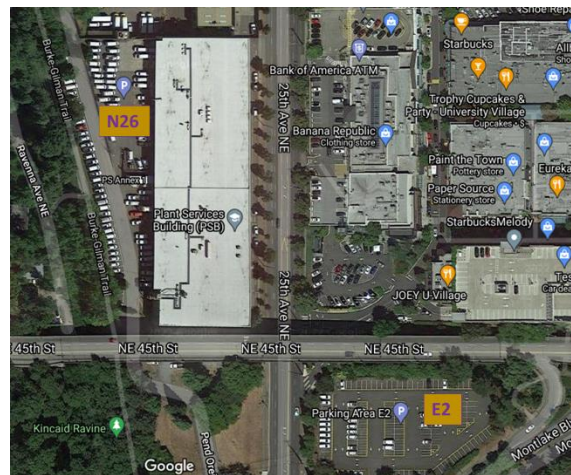

Figure 4.5. N26 and E2 Parking Lots

4.2 CHARGING SCENARIOS

For each charging scenario, I analyze the energy, power, and charger requirements calculated according to the procedure in Section 3.3. Each scenario has associated assumptions. Based on the validity of the assumptions and the tradeoffs between energy, power, and cost, UW Transportation can operate using a charge management and charge scheduling system that is most feasible for their needs.

4.2.1 *Case 1: No Charge Scheduling and No Charge Management*

In this case, vehicles are charged on a 6-day cycle, with some vehicles charging every day, some charging every second day, and some charging every third day. Since vehicles are not scheduled, the first day of the charging cycle is day 1. As shown in Table 4.1, all vehicles charge on day 1 when following this unscheduled 6-day cycle.

Table 4.1. Unscheduled Charging Cycle

Day of Charging Cycle	Vehicles that Charge Every Day	Vehicles that Charge Every 2 nd Day	Vehicles that Charge Every 3 rd Day
1	X	X	X
2	X		
3	X	X	
4	X		X
5	X	X	
6	X		

Additionally, charging is unmanaged, meaning each vehicle charges at its maximum allowable power according to Table 4.2 until fully charged. Based on the energy requirements of each vehicle, the day each vehicle is charging, and the power required to charge, each vehicle requires a certain number of chargers. For example, for a vehicle that is charged every day and needs 20 kWh to get to full charge at the end of each day, charging it will require 2 hours if it charges at 10 kW. Since there are 8 hours available for off-peak charging each day, then this vehicle requires 0.25 chargers because 4 vehicles with the same requirements could be cycled through 1 charger every day.

Table 4.2. Electrified Vehicle Maximum Charging Power

Vehicle Type	Maximum Charging Power (kW)
Chevrolet Bolt	7.2
Ford E-Transit	11.3
Ford F-Series EV	7.2
Kia Nero EV	7.4
Isuzu N-Series LDV	11
Toyota Sienna PHEV	6.6

Since chargers require permanent infrastructure, the total number of chargers needed in the unmanaged unscheduled scenario is equal to the maximum number of chargers needed on any given day. All the vehicles are charged on day 1, so the number of chargers needed for this case is equal to the number of chargers needed on day 1. This results in the charger distribution shown in Figure 4.6.

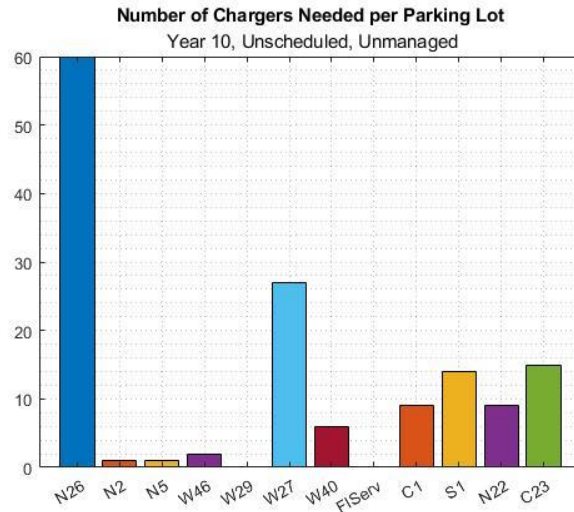

Figure 4.6. Year 10 Chargers per Parking Lot for Case 1

The N26 parking lot houses 60 chargers and is the most charger-populated location. In total, the fleet of vehicles requires 144 chargers. Since 538 total vehicles are electrified by the end of year 10, this means that less than one charger is required per vehicle. Therefore, vehicles must be swapped into and out of chargers throughout the night to minimize the number of chargers in

this case. Figure 4.7 shows the number of chargers required each year over the ten-year electrification plan. The height of each bar still corresponds to the total number of chargers after year 10, and each color block corresponds to the additional number of chargers added each year. For example, the gold color block towards the bottom of the chart is the number of chargers added to the existing infrastructure in year 1, and the existing infrastructure is represented by purple color block at bottom of the graph. Since the composition of the replacement fleet each year is similar, the number of chargers added to each parking lot each year stays mostly consistent.

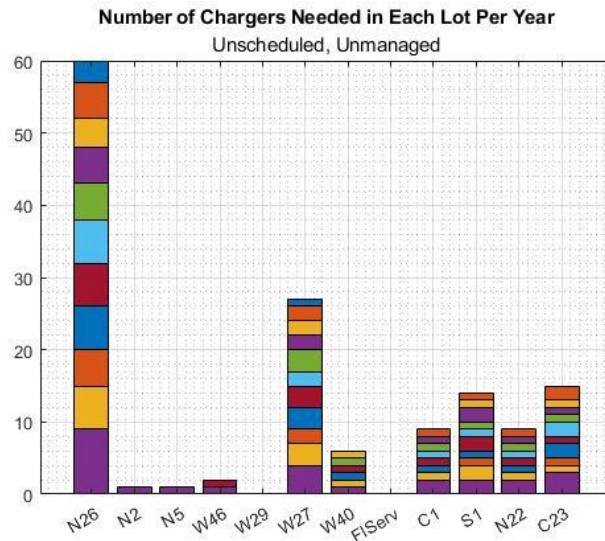

Figure 4.7. Chargers per Parking Lot Each Year for Case 1

The total power required to charge the fleet on day 1 of the cycle is approximately 1.73 MW. All vehicles are charging on day 1 and they are charging at their maximum power. However, since the vehicles are switched into and out of chargers throughout the night, power usage is staggered. Therefore, this value is less than the sum of the maximum power to charge each vehicle.

The unmanaged, unscheduled case results in large energy requirements. In all cases, the energy required to charge the entire fleet over an entire cycle is the same since it is based on vehicle usage and energy capacity. However, when charging is unmanaged, the maximum amount of

energy to charge the vehicles on any given day of the cycle is about 6.46 MWh, which is the largest amount of energy needed on a given day for any case since all of the vehicles are charging on the same day on day 1.

4.2.2 *Case 2: Charge Scheduling and No Charge Management*

When charging is scheduled but unmanaged, fleet vehicles are charged at their maximum rate. However, a schedule determines the day in which each vehicle is charged. In this case, the schedule minimizes the number of chargers required per day by offsetting the charging schedule of vehicles which charge every 2nd day and every 3rd day.

Using the unmanaged, unscheduled case, 78 chargers are needed for the vehicles that charge every 2nd day and 24 chargers are needed for the vehicles that charge every 3rd day. To minimize charger requirements, some of the vehicles which need to charge every 2nd day are charged on days 1, 3, and 5 of the cycle while the remainder are charged on days 2, 4, and 6 of the cycle. Similarly, vehicles which need to charge every 3rd day are distributed so that some charge on days 1 and 4, some charge on days 2 and 5, and the rest charge on days 3 and 6. The number of vehicles charging on each day is based on how many chargers each vehicle needs.

Figure 4.8 shows the number of chargers needed in each parking lot per year for the unmanaged, scheduled case. This case only requires 96 chargers, which is over a 33% decrease in the number of chargers required in case 1 and is the least number of chargers of any scenario. Once again, the N26 parking lot houses the most chargers because the most vehicles are parked in that location.

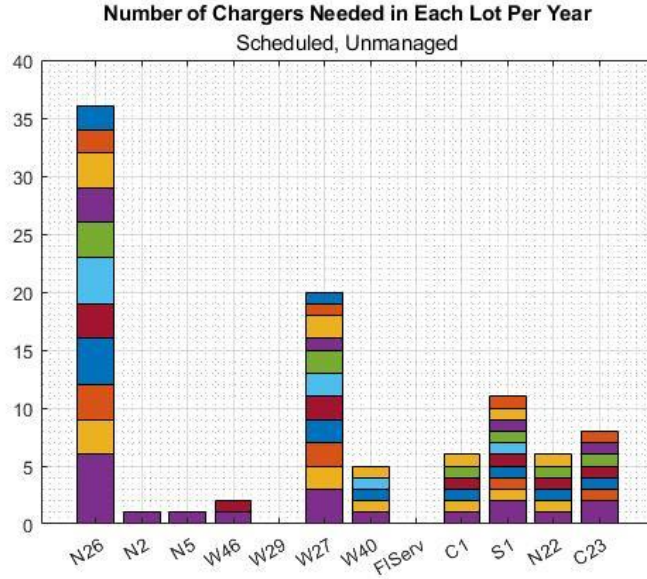

Figure 4.8. Chargers per Parking Lot Each Year for Case 2

The power and energy required to charge varies based on which vehicles are charging each day. As shown in Figure 4.9, the power requirements are around 2.5 MW per day. The value each day is similar because the maximum power for each vehicle type stays within the range of 6.6-11.3 kW. The energy requirements stay around 4 MWh on any given day and are similar since the number of chargers needed is spread evenly through each day and is a function of energy requirements.

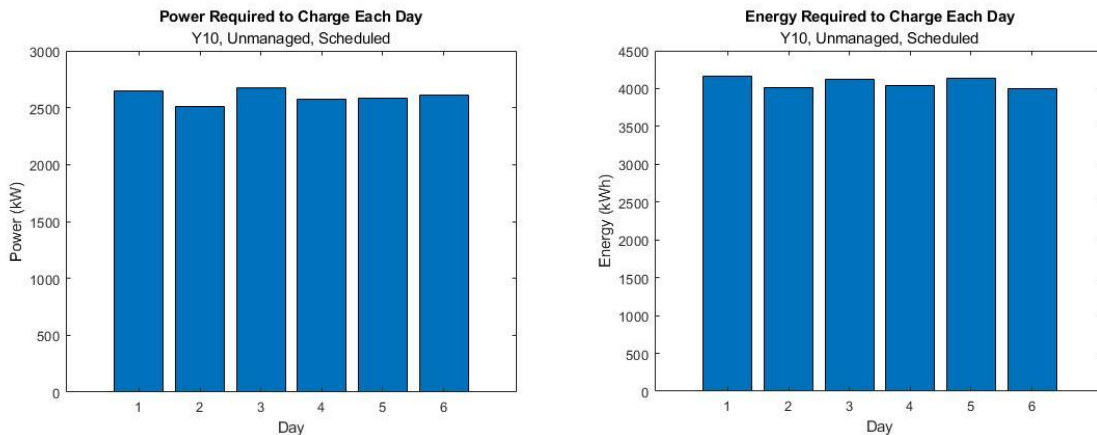

Figure 4.9. Year 10 Power and Energy Required to Charge Each Day for Case 2

4.2.3 *Case 3: Charge Management and No Charge Scheduling, Charge Every Vehicle Every Day*

If every vehicle is charged every day, the vehicles that would normally be charged every 2nd day or every 3rd day require less energy to charge each time they are plugged in. This case is one approach to reduce daily energy and power requirements by having each vehicle charge for as long as possible during off-peak hours. Therefore, only those vehicles which require 8 or more hours to fully charge at maximum power are charged at maximum power. All other vehicles can be charged at a reduced power. Also, since the miles driven per day and therefore the energy requirements use the assumption that vehicles are driven only Monday through Friday, “every day” in this case refers to every weekday.

Since every vehicle is charging every day and each vehicle requires at least 8 hours to charge, then the ratio of chargers to vehicles is one-to-one. Using this method to minimize power and energy requirements per day results in maximization of the number of chargers. Figure 4.10 shows the number of chargers required per year in this scenario.

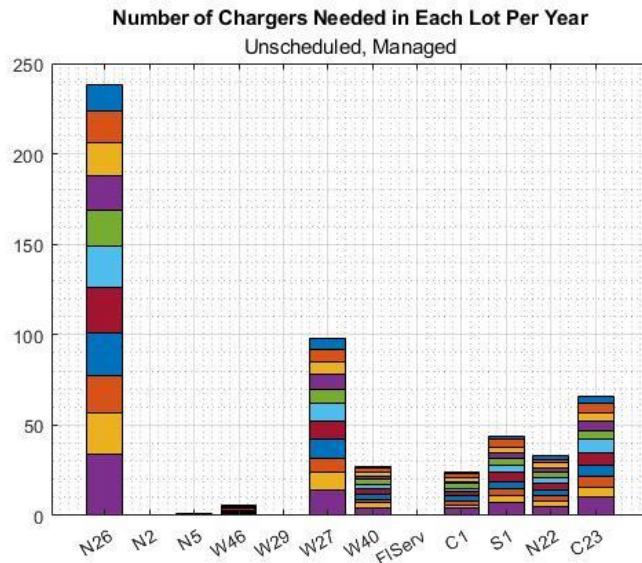

Figure 4.10. Chargers per Parking Lot Each Year for Case 3

The total power required each day is 509 kW and the total energy required each day is 4.16 MWh. If every vehicle is charged every day, then the power requirements are about one fourth of that for the unmanaged, unscheduled case (case 1) and about one fifth of the power requirements for the unmanaged, scheduled case (case 2). This case also results in the lowest energy requirements of the three scenarios.

Charging every vehicle every weekday is an effective approach to reducing energy and power requirements for charging the entire fleet. Additionally, since there is a charger for every vehicle, then there is no need for an attendant to move vehicles in and out of charging parking spots throughout the night. The downside is that charging infrastructure for 538 chargers is expensive and takes up space. Parking lot N26 requires almost 250 chargers and parking lot W27 requires about 100 chargers. This scale of charging infrastructure may not be feasible given space constraints, so charging infrastructure would have to be expanded to other nearby parking lots.

4.2.4 *Case 4: Charge Management and No Charge Scheduling*

In this case, each vehicle charges for the maximum amount of time as in case 3. However, rather than being charged every day, the vehicles are charged on a 6-day cycle as in case 1 and Table 4.1. Since all vehicles charge on day 1 of the cycle and each vehicle requires an entire day to charge, this case, like case 3, requires all 538 chargers. The breakdown of chargers in each location is the same as in Figure 4.10.

Since charging is not optimized with scheduling, this case requires a greater power and energy than case 3, using 806 kW and 6.46 MWh for day 1 when all vehicles are charging at once. These power requirements are still less than the unmanaged and unscheduled case since charging is spread out over a longer period of time. The energy requirements are exactly the same as in the

unmanaged and unscheduled case because the same vehicles are charging on the same days, just using a different number of chargers. Nevertheless, the benefit of this case is that it is simple to implement and reduce power requirements of the fleet. As in case 3, vehicles do not need to be switched in and out of chargers throughout the night since there is a one-to-one vehicle to charger ratio.

4.2.5 Case 5: Charge Management and Charge Scheduling

Case 5 is an attempt to minimize power requirements with scheduling and charge management. The vehicles are charged on a 6-day cycle for the maximum amount of time. As in case 2, the vehicles charged every 2nd day are spread among days 1, 3, and 5 and days 2, 4, and 6. Vehicles charged every 3rd day are spread among days 1 and 4, 2 and 5, and 3 and 6. To choose which vehicle charges each day, the vehicles are spread so that power requirements are the same every day. Figure 4.11 shows the power requirements on each day of the cycle using this scheduling method, which is about 509 kW. This power requirement is roughly the same as that for charging every vehicle every weekday.

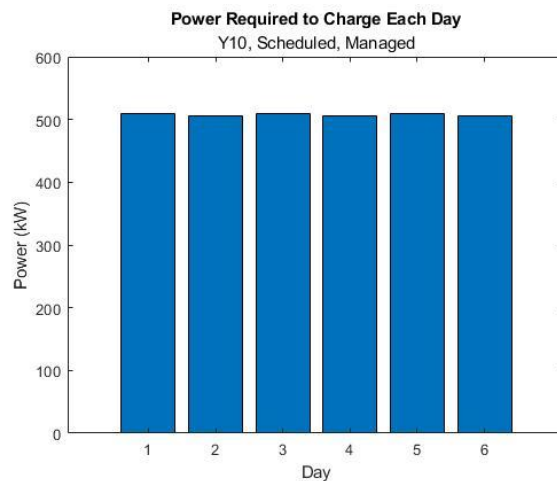

Figure 4.11. Year 10 Total Power each Day for Case 5

Since each vehicle is charged for at least 8 hours, every vehicle requires one charger. However, due to the distribution of vehicles, at most 315 vehicles are charging on any given day of the cycle. As shown in Figure 4.12, this maximum is reached on day 3 of the cycle, but the number of chargers needed each day are fairly consistent, ranging from 303 on day 4 to 315 on day 3. Therefore, only 315 chargers are required. Figure 4.13 shows the charger requirements for each year in each parking lot.

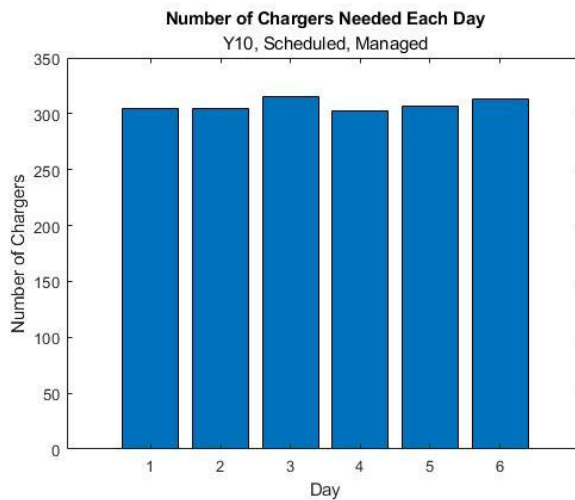

Figure 4.12. Year 10 Total Chargers each Day for Case 5

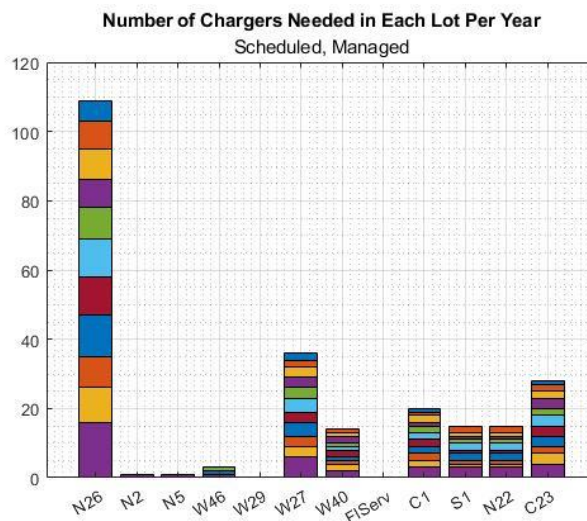

Figure 4.13. Chargers per Parking Lot Each Year for Case 5

Using charge management and scheduling in conjunction effectively reduces power requirements when compared with of the other cases that use a 6-day cycle. The energy requirements for this case are on par with case 2 (unmanaged, scheduled) and 3 (charge every vehicle every day) and less than that of the other cases for a 6-day cycle due to the charge scheduling.

4.2.6 *Case 6: Weekend Charging*

Since the vehicles in the fleet have a wide range of usage each day, some vehicles do not use much energy each day and can go many days without charging. This case uses an SOC calculation that is not adjusted to group vehicles into charging every day, every 2nd day, and every 3rd day, so the calculation is different than for the 6-day cycle. Instead, vehicles are grouped by those that can go at least 5 days without charging and those that need to charge more frequently than once every 5 days. Vehicles that can be charged every 5 or more days are charged on the weekend so that half of them charge on Saturday night and half of them charge on Sunday night. All other vehicles are charged every day on the weekdays. Like in the other cases, this case assumes that vehicles are only used on the weekdays so that their energy is not being depleted on weekends; therefore, the weekends are only used to reduce the number of vehicles charging on any given day.

A total of 390 vehicles can be charged on the weekend, with half charging on Saturday night and half charging on Sunday night. This means that 148 vehicles are charged on the weekdays. This case also uses charge management so that each vehicle charges for 8 hours or more to minimize power requirements. Therefore, the maximum number of chargers in use on any given day is 195, corresponding to the maximum number of vehicles charging on any given day. However, since each vehicle requires a charger in a specific location, the infrastructure must support 257 chargers based on the maximum number of chargers needed in each location. This

means that each day, a portion of the chargers will not be in use. Figure 4.14 shows the breakdown of vehicles in each parking lot each year.

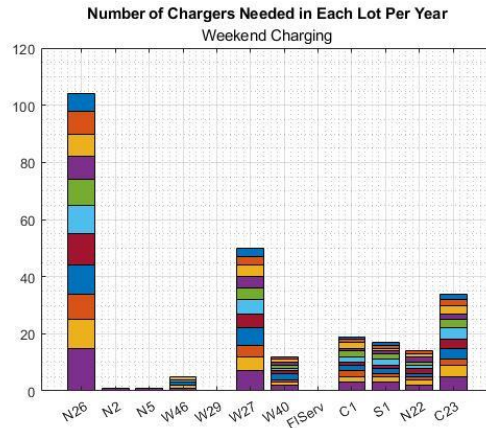

Figure 4.14. Chargers per Parking Lot Each Year for Case 6

Since this case uses charge management and vehicles are spread so that approximately one third of the fleet is charged each day, this case results in the relatively low power requirements compared to other scenarios at only 548 kW maximum per day. Additionally, this case results in low energy requirements of 4.42 MWh maximum per day due to the lower number of vehicles charged each day. Attendants do not need to move vehicles in and out of charging parking spots each night as long as vehicles are parked at their designated charging parking spot at the end of the day on the day they are charged. However, on weekends the weekday charging vehicles must be moved out of the charging parking spots to accommodate the weekend charging vehicles and vice-versa.

4.2.7 Case 7: Charge Half the Fleet Each Day

As in the other cases, this case assumes that vehicles are being used only on weekdays. Half of the fleet vehicles are charged each day based on the amount of power they require. To accomplish this, vehicles are divided into two categories: those which require above average power to charge

and those that require below average power to charge. Those two categories are split in half so that each day, half of the above average power vehicles are charged and half of the below average power vehicles are charged. However, there are still some vehicles which have large energy requirements and must be charged every day.

This charging scheme requires 358 chargers. 61 vehicles require charging every day, which results in about 300 total vehicles charging each day. As in case 6, since each vehicle requires charging at a specific location, more chargers are needed than vehicles charging each day so some chargers will be vacant on certain days. Figure 4.15 shows the chargers per parking lot each year.

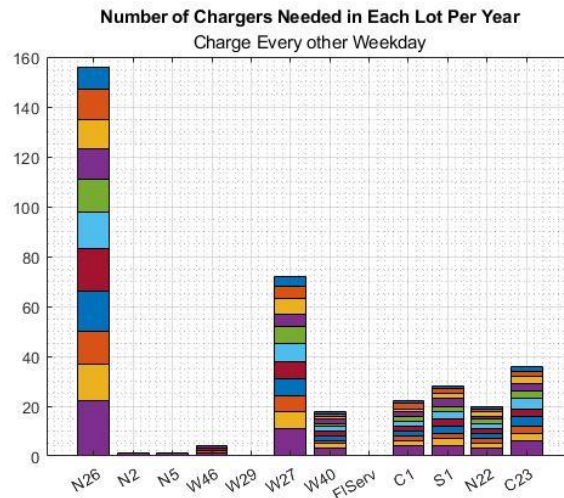

Figure 4.15. Chargers per Parking Lot Each Year for Case 7

Charging half of the fleet each day requires a maximum daily power of 531 kW and maximum daily energy of 4.3 MWh. Compared to the other cases, this case has relatively low requirements for power and energy due to the charge management and scheduling. It still requires more power and energy than managed, scheduled charging (case 5) and charging every vehicle every day (case 3). The number of chargers required is also reasonable but not the lowest. Although vehicles do not need to be switched in and out of chargers during the night, they still will have to

be parked in a different parking spot at the end of each day of use depending on whether it is their day to charge.

4.3 COST ANALYSIS

As described in Section 3.3.4, the cost analysis involves both fixed and annual costs comparing the original fleet with an electrified fleet. Figure 4.16 shows the costs associated with each scenario over 9 years starting from 2032, which is year ten of the ten-year electrification plan. The original fleet, shown by the steep, blue line, has a lower initial cost but higher annual cost than all the electrification scenarios. For the electrified fleet, the total cost each year is a sum of the cumulative costs of maintenance and electricity usage and of the initial fixed cost for vehicle purchasing, chargers, and charging infrastructure. For the conventional fleet, the total cost each year is the sum of the cumulative costs of maintenance and fuel usage and of the initial fixed cost for vehicle purchasing. Maintenance, fuel usage, and electricity usage costs depend on vehicle use and change each year due to projected fuel and energy costs as well as inflation. Vehicle usage is assumed to be the same each year.

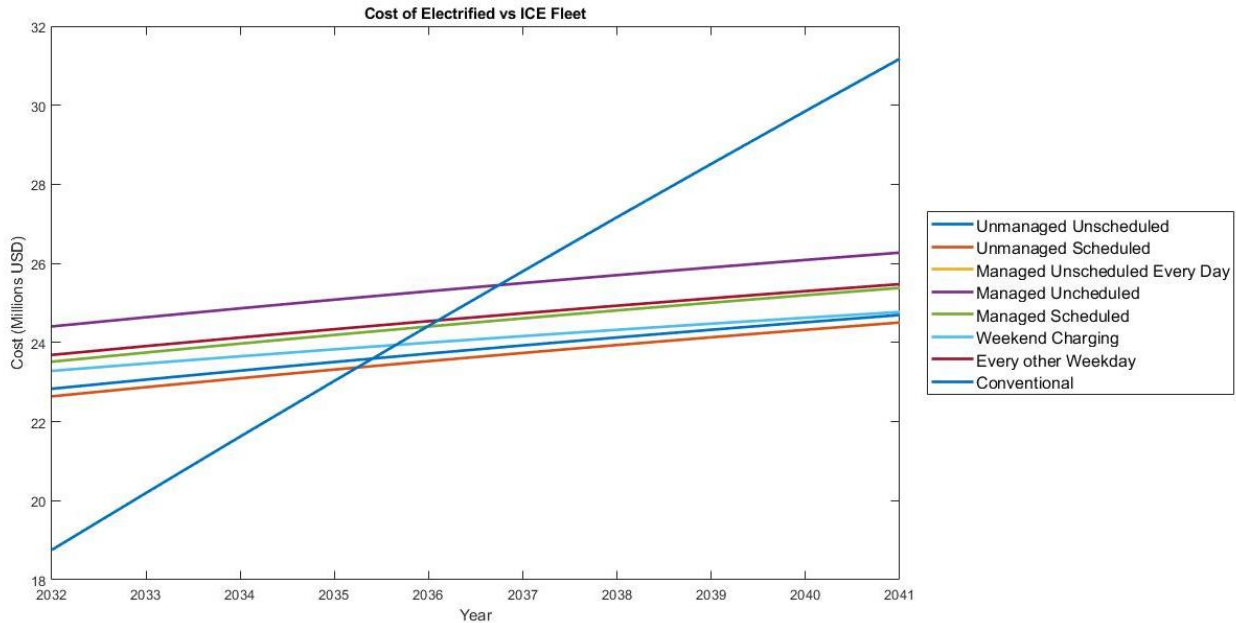

Figure 4.16. Costs of the Original versus Electrified Fleet

As shown by the y-intercept in Figure 4.16 and in Table 4.3, the total fixed cost is similar for the electrified scenarios, ranging from \$22.47 million in the unmanaged scheduled case to \$24.24 million in the managed unscheduled cases. This is consistent with the number of chargers required for each case since it is a function of the number of chargers required. The conventional fleet has the lowest initial cost at \$18.49 million since it is a reflection of only the cost to purchase the vehicles and there are no charger costs associated with it. However, as evident by the steep slope for the conventional fleet in Figure 4.16, the recurring costs for the conventional fleet are greater than those for an electrified fleet since ICE fuel and maintenance are more expensive than EV energy and maintenance.

Table 4.3 also details the total cost of ownership from 2032 through 2041. This is the cumulative cost for the vehicle fleet over its lifetime. The TCO is lowest for the unmanaged, scheduled case due to low energy requirements and a low initial cost and highest for the conventional fleet since the recurring costs are greatest. Weekend charging has low recurring cost

and would likely be the least expensive over a longer time span assuming there are no vehicle replacements and infrastructure upgrades. Regardless, all electrified charging scenarios are more cost effective than managing a conventional fleet.

Table 4.3. Vehicle Fleet Costs

Case	Unmanaged Unscheduled	Unmanaged Scheduled	Managed Unscheduled, Charge Every Vehicle Every Day	Managed Unscheduled	Managed Scheduled	Weekend Charging	Charge Every other Weekday	Conventional Fleet
Initial Fixed Cost (Million USD)	22.67	22.47	24.24	24.24	23.35	23.12	23.52	18.48
TCO (Million USD)	24.70	24.51	26.27	26.27	25.38	24.77	25.48	31.18

4.4 UW TRANSPORTATION FLEET VEHICLE USAGE SURVEY

The UW Transportation fleet vehicle usage survey provides insight into the fleet vehicles usage to help justify the assumptions made in this work. 19 people responded to the survey with information about 23 total vehicles.

70% of the vehicles are used only on weekdays. The exceptions are the mail trucks and the vehicle for the golf range. As shown in Figure 4.17, more than half the vehicles are driven for an average of 3 to 5 hours per day and over 75% of the vehicles are driven for 5 hours or less. Similarly, vehicles are usually not driven very far. Over half the vehicles are driven less than 10 miles each day on average. Only two vehicles are driven greater than 35 miles on average per day.

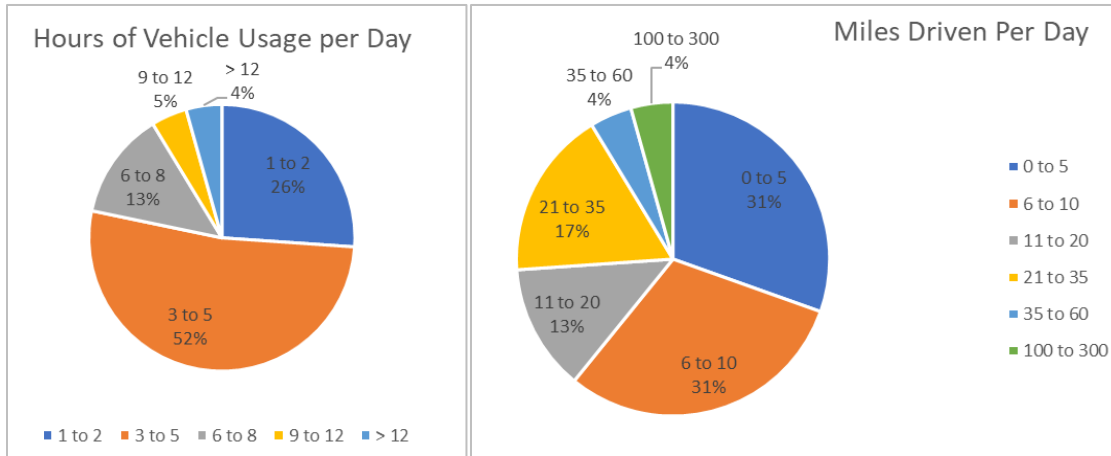

Figure 4.17. Fleet Vehicle Usage

This survey gives interesting insights into unique vehicle usage scenarios that pose challenges for 100% electrification. For example, an F250 that is used by the forestry department is driven 100 to 300 miles during each use since it is used for trips to forests in Washington and Oregon. The vehicle is driven on logging roads and kept overnight at hotels. Therefore, there is limited or uncertain access to EV chargers on the route that the vehicle is driven.

Some vehicles are used sporadically and have inconsistent use, such as the emergency management Ford Explorer. According to the respondent for this vehicle, the vehicle is sometimes only driven once or twice a week and can go months at a time without any use. Additionally, it is not used during the same times of day or for the same amount of time each day it is used. Similarly, the Ford Explorer used for UW Public Safety can be used at any time of day and parks in various locations when the department is responding to an incident.

Despite these edge cases, vehicle usage for many departments is similar each day and minimal, which provides a great opportunity for charge management and charge scheduling.

Chapter 5. CONCLUSION AND FUTURE WORK

The results of the calculations for each charging scenario and the vehicle usage survey can guide UW Transportation through the process of complete fleet electrification. Each charge management and charge scheduling case has benefits and challenges associated with it. Some cases are most feasible from an infrastructure and cost standpoint, while others are logistically simpler but require more construction and funding. Using the data-driven results and conclusions presented in this thesis work, any organization can gain insight into the power and energy implications of fleet electrification.

5.1 CASE COMPARISONS

The power and energy trends for each charging scenario are very similar, as shown in Figure 5.1.

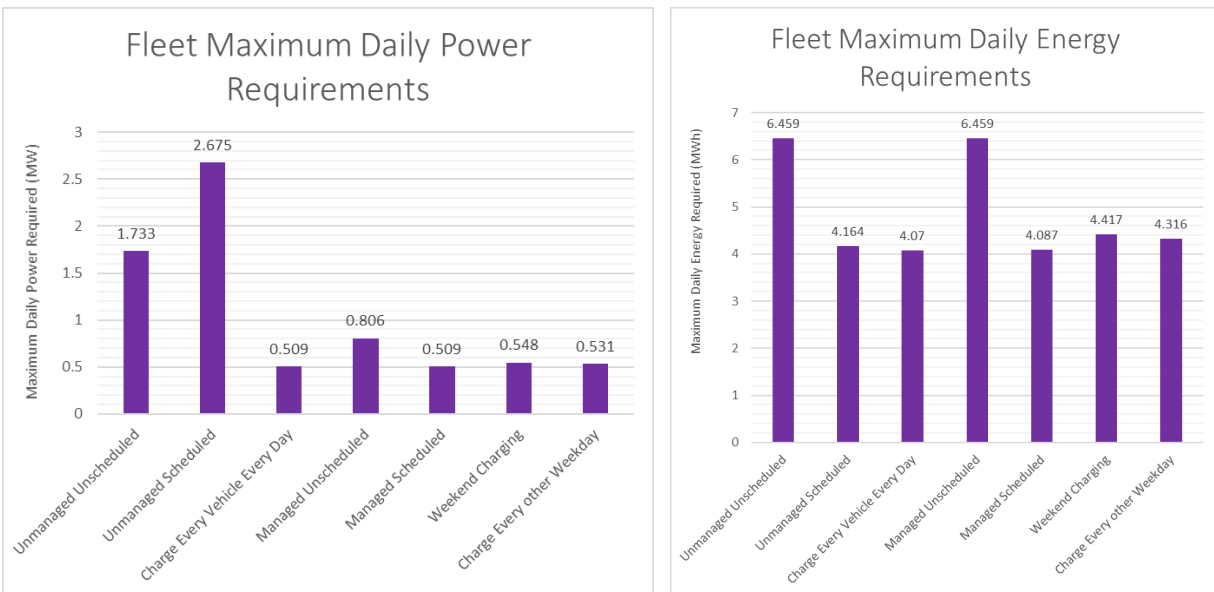

Figure 5.1. Power and Energy Requirements for Each Charging Scenario

Charging every vehicle every weekday, managed scheduled charging, utilizing weekends for charging, and charging every 2nd weekday require the least amount of power and energy compared to the other cases, needing about 500 kW and 4 MWh each day. Managing charging in some way reduces power requirements compared to unmanaged charging. This makes sense because the definition of charge management is to spread out charging among a larger time period to lower power requirements. Unmanaged, scheduled charging requires the most power because the vehicles are scheduled to minimize the number of chargers, which does not optimize the power requirements. If the power output from the feeder of a charging site is limited, it is especially important to employ charge management and charge scheduling techniques to avoid the need for an infrastructure upgrade.

The energy requirements can be reduced by scheduling charging. Employing solely charge management does not reduce energy requirements, which is evident from Figure 5.1 in which the unmanaged unscheduled case has the same energy requirements as the managed unscheduled case. Since the amount of energy for the entire fleet to charge over one cycle is the same for all cases, the daily energy required depends on which vehicles are charging which day and the amount of use since the previous charging event for each vehicle. For both of the unscheduled cases, the same vehicles are charging each day and each vehicle has the same amount of use between charging events. Therefore, regardless of the power the vehicles charge at, the energy required will be the same. Reducing energy requirements is not only important for minimizing infrastructure upgrades, but also for avoiding charging during peak hours.

As discussed in Section 4.3, the three cases with lowest costs over time are unmanaged scheduled charging, unmanaged unscheduled charging, and weekend charging. 9 years after the fleet is fully electrified, the cost of the lowest cost charging scenario (unmanaged scheduled) is

about \$1.8 million less than that of the highest cost charging scenario (managed unscheduled) for the electrified fleet. The difference in initial fixed cost for these two cases is about \$1.7 million since the recurring costs for each case are similar. Therefore, to minimize costs, UW Transportation should choose a charging scheme that not only has a low fixed cost but also a low annual cost. Doing so will save UW Transportation millions of dollars in the long run.

It is interesting to note that case 1 (unmanaged unscheduled charging) is not the most expensive even though it has relatively high power and energy requirements compared to most of the other cases. This is because although charging is not scheduled throughout the charging cycle, each charger can still be used for multiple vehicles in one day, significantly reducing the number of chargers needed and therefore the fixed cost. Additionally, the annual energy costs for each scenario are similar since most vehicles can be charged off-peak even in situations with higher energy requirements for each charge due to more days of use between charging events. Therefore, initial fixed cost often plays a larger role in determining long-term cost than annual costs do.

Also, as shown in Figure 4.16, the annual cost of the fleet in its current composition with mostly ICE vehicles is much greater than that of any of the electrified fleet cases. This is due to fuel being more expensive than electricity. Regardless of which charging scheme UW Transportation chooses, electrifying the fleet is a worthwhile investment.

Logistically, some cases are more complicated than others. Table 5.1 summarizes the need for charger swapping in each case. Charger swapping is when any number of fleet vehicles must be moved out of a charging parking spot to accommodate other vehicles which need to be charged. UW Transportation already employs 4 vehicle attendants who work early mornings to early afternoons to clean and service UCARs. These attendants could be used to swap vehicles in and out of chargers without added cost to UW Transportation. However, since charging occurs at night,

this does not line up with the attendants' current work schedule and may pose a barrier to using attendants for charger swapping. Both of the unmanaged cases require vehicles to be moved throughout the day each day. This reduces the number of chargers needed since each charger is used for multiple vehicles each day but would require attendants to move vehicles to and from parking spots many times each day and on a strict schedule. Managed unscheduled charging, managed scheduled charging, and charging every 2nd weekday require charger swapping every weekday, but after the necessary vehicles are moved in and out of charging parking spots once, they do not need to be moved again until the next day. Weekend charging only requires charger swapping on Saturday, Sunday, and Monday since all of the vehicles which are charged on weekends are charged every day using the same charger. Finally, charging every vehicle every weekday does not require charger swapping at all since each vehicle has a designated charger and takes the entirety of off-peak hours to charge each weekday.

Table 5.1. Charger Swapping Requirements for Each Case

Case	Unmanaged Unscheduled	Unmanaged Scheduled	Charge Every Vehicle Every Day	Managed Unscheduled	Managed Scheduled	Weekend Charging	Charge Every other Weekday
Requires Charger Swapping throughout the Day	x	x					
Requires Charger Swapping every Weekday	x	x		x	x		x
Requires Charger Swapping some Days						x	

Considering the energy, power, cost, and charger swapping requirements for the fleet, weekend charging is the best option, assuming there is an attendant available to move vehicles in and out of charging parking spots a few times a week. It is cost effective, requires a relatively low amount of energy and power, and requires the third least amount of chargers out of all the cases. This case involves some scheduling for attendants and does not guarantee that a user will be able to pick up a vehicle at the same parking spot where they dropped it off. However, UW Transportation has indicated that they can hire an attendant to move vehicles if necessary. Also, if vehicles are placed in the same lot (but different parking spot) than when the users last left them, or if users can track vehicles on an app or web interface, then these concerns can be addressed.

Charging every vehicle every weekday is also a feasible option from a logistics standpoint. Although the costs are higher than other electrified cases because of initial investment in charging infrastructure, the energy and power requirements are low. Due to the simplicity of this charging scheme, the user can plug in a vehicle to a smart charger in a designated parking spot after using it and find it in the same parking spot when picking it up the next time. The smart charger can determine when charging starts, stops, and the charging rate, so the user does not need to do anything other than plug the vehicle in at the end of use and unplug it at the beginning of use. Furthermore, this scheme could easily be adapted to include vehicles which are used on the weekends, since the analysis in this thesis assumes vehicles are used only on weekdays whereas survey results show this is usually, but not always, true. The main concern with this case besides cost is that space limitations could prohibit 538 chargers from being installed on campus. However, expanding charger infrastructure to other parking lots could solve this issue.

Other cases that have relatively low energy, power, cost, and charger requirements are managed scheduled charging and charging every other weekday. Both of these cases require

vehicles to be swapped into and out of chargers every weekday, which makes them more logistically complicated than weekend charging or charging every vehicle every weekday.

5.2 INFRASTRUCTURE IMPLICATIONS

The charging infrastructure for each parking lot is fed from the electrical panel of the nearest building unless the lot is in a parking garage which has its own panel. For example, the N2 parking lot is fed from the Denny Hall panel. According to UW Facilities, the panels are usually rated to accommodate far more load than they realistically experience due to electrical codes. Nevertheless, it is important to verify that the additional load from electric vehicle charging will still meet the capacity availability of the panels in each charging parking lot.

In a worst-case scenario, the fleet requires the maximum amount of energy to charge and the existing load on each parking lot panel is at peak. According to data from UW Facilities, energy requirements are usually greatest than the winter months, ranging from about .7 MWh to 4.3 MWh depending on the parking lot. Figure 5.2 shows the energy requirements for some of the lots every 15 minutes for the day of the year in which the load is the greatest. These values are based on the 2021 meter data for the feeders at buildings nearest to each parking lot. The energy requirements are greatest during daylight hours, with the left-hand side of the x-axis corresponding to 12am and the middle corresponding to 12pm. Most vehicles charge between 10pm and 6pm, which does not line up with peak load times. However, for the purposes of comparing daily energy existing load to daily charging energy, the sum of the energy values for each lot in Figure 5.2 is used.

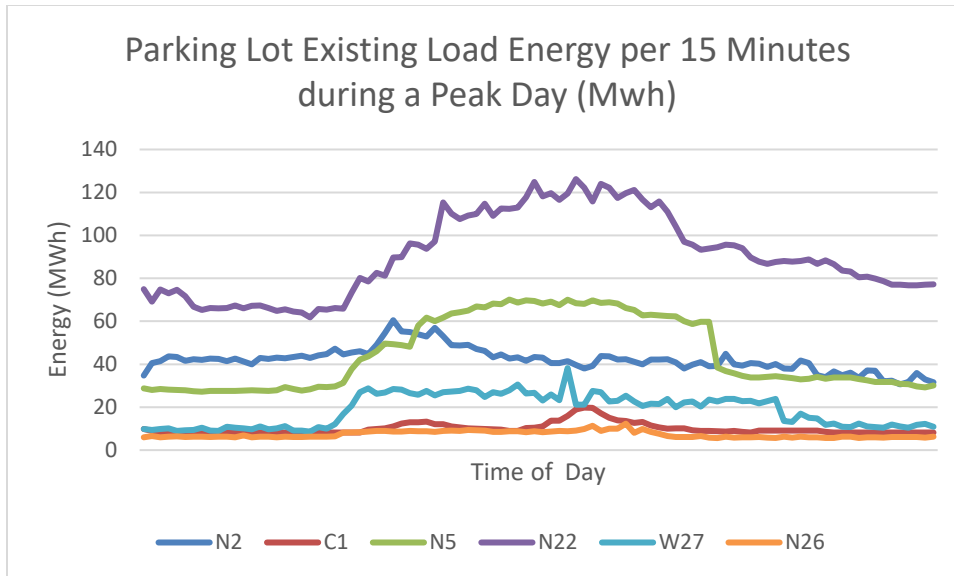

Figure 5.2. Parking Lot Existing Load Energy

The remaining capacity at each feeder after subtracting the existing load from the energy capacity (which is found from the campus one line diagram provided by UW Facilities) must be greater than the energy required to charge in order for a site to accommodate the extra load from charging when the entire fleet is electrified. In almost all cases, the existing infrastructure at each parking lot location can accommodate the charging load. There are two reasons why charging infrastructure cannot accommodate the load:

1. The existing panel has a low rating since it usually feeds a small load. This is the case with parking lot C23 for the Plant Operations Building. To mitigate this issue, some chargers can be fed off of nearby buildings such as for the Facilities Services buildings which are located on the same switchboard as the Plant Operations Building.
2. Many vehicles are located in the same parking lot. This is the case with lot N26, which houses at most 239 EVs. Rather than updating charging infrastructure, some of these vehicles could be moved to a nearby lot such as E2 or E1. In fact, UW Solar is working

with UW Transportation to install a solar canopy and chargers at the E1 lot, so that would be a good location for some of the vehicles initially intended for the N26 lot.

The worst-case scenario described above could also easily be avoided using charge management and charge scheduling, likely eliminating the need to plan for charging infrastructure in parking lots in which it does not already exist. Therefore, based on the results of this thesis, UW will be able to accommodate the extra load of a completely electrified fleet without infrastructure upgrades.

In addition to considering the individual feeder capacity at each charging location, UW Transportation must also consider the total power available to the campus grid. Seattle City Light feeds most of the campus distribution grid. According to UW Facilities, UW can expect a maximum of 60 MW of generation capacity from the SCL interconnect. Figure 5.3 shows the daily campus load as calculated from a monthly average of campus load power data for the 2021 fiscal year, which does not include the load from a completely electrified fleet. Since this data is averaged, it does not contain peak values. UW Facilities' data supports that the peak power usage on campus is 52 MW, leaving at most 8 MW available.

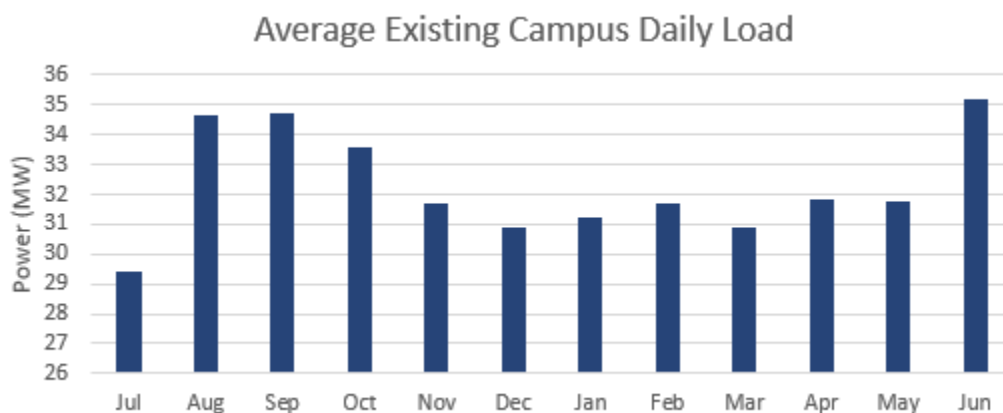

Figure 5.3. Total Campus Power per Month

The maximum daily power requirements for the electrified fleet corresponds to the unmanaged, scheduled charging scheme and is approximately 2.68 MW. In high demand months such as June, the combined monthly average power for the existing load plus maximum load for the unmanaged, unscheduled charging scheme would be about 38 MW, which is still more than 20 MW less than the maximum power that SCL can deliver to UW. However, Figure 5.3 does not reflect peak hourly load values. On certain peak days when there are only 8 MW of power available, the unmanaged and unscheduled charging scenario comes closer to constraining the grid capabilities, especially if the peak campus load and peak electrified fleet load occur at the same time. It further reduces total campus load requirements to use schemes for which the power requirements are closer to 0.5 MW. If the campus infrastructure expands in the future, then it will be important to minimize any extra load added to the distribution grid.

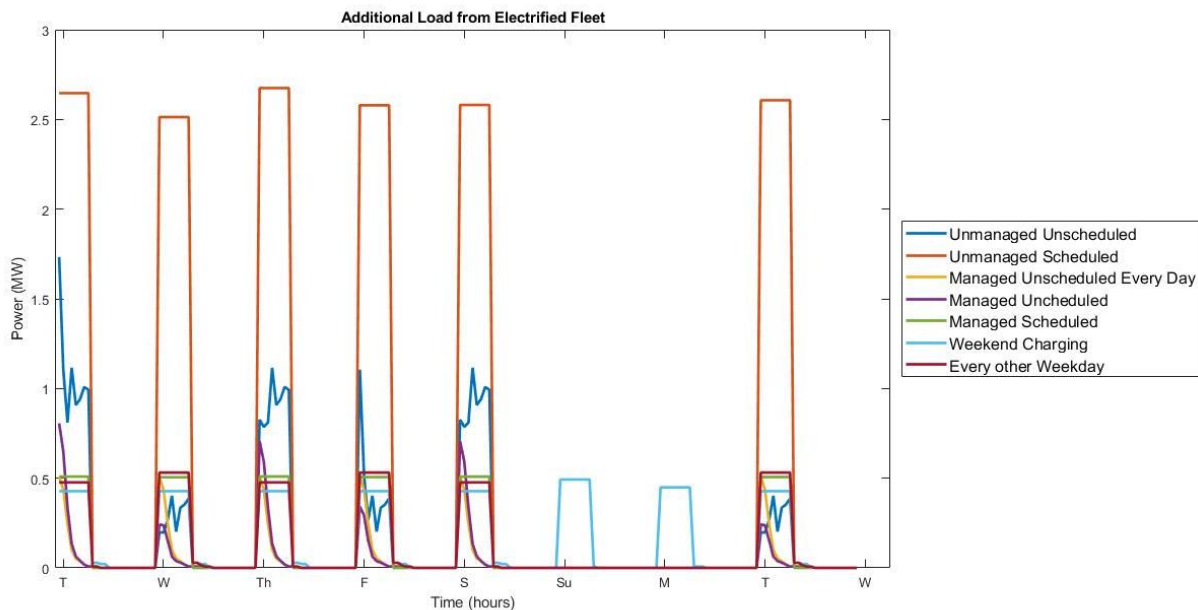

Figure 5.4. Electrified Fleet Hourly Load

To better visualize the typical load throughout the 6-day weekly cycle for each charging scenario, Figure 5.4 shows the hourly power curves, assuming all vehicles begin charging at the

beginning of off-peak hours, which is 10pm. The tick marks represent midnight, meaning that the highest power requirements usually occur at night and in early morning. Some power is required during peak hours for vehicles that cannot charge at maximum power within an 8-hour time span.

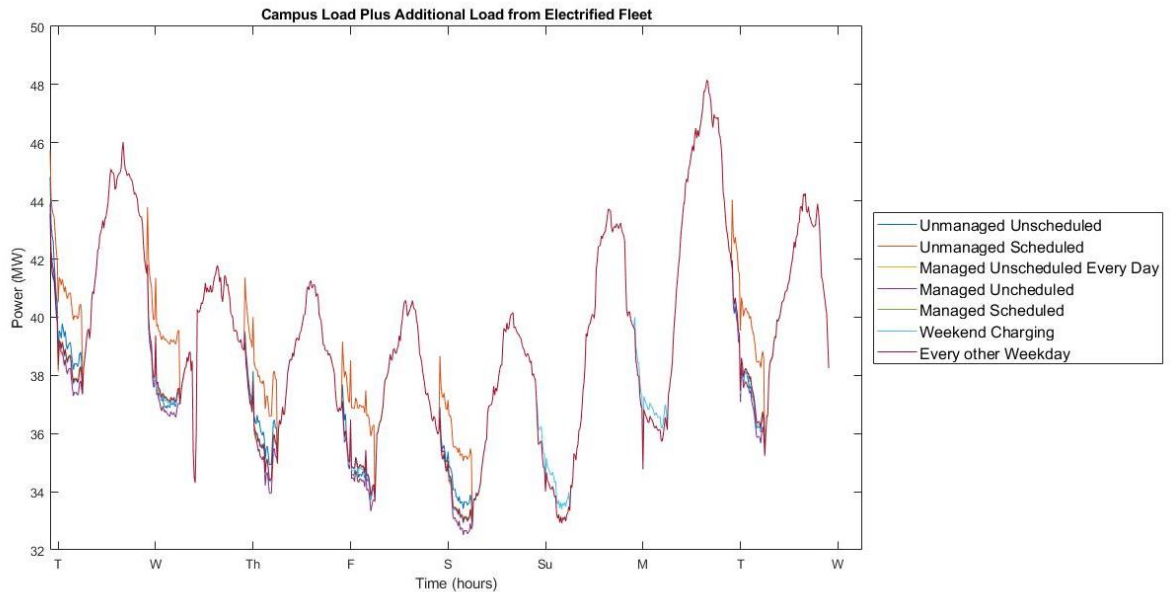

Figure 5.5. Total Hourly Campus Load Including Electrified Fleet Load

Figure 5.5 shows how this additional load effects the overall load profile of campus for all seven charging scenarios. The electrified fleet power in each scenario is added to the power requirements from the week that had the highest power requirements during the 2020-2021 academic year to show the case in which the grid would be most constrained. This week occurs at the end of July, likely due to hot summer temperatures causing buildings to use more power for air conditioning. The unmanaged, scheduled scenario is represented by the red curve which reaches the greatest maximum load.

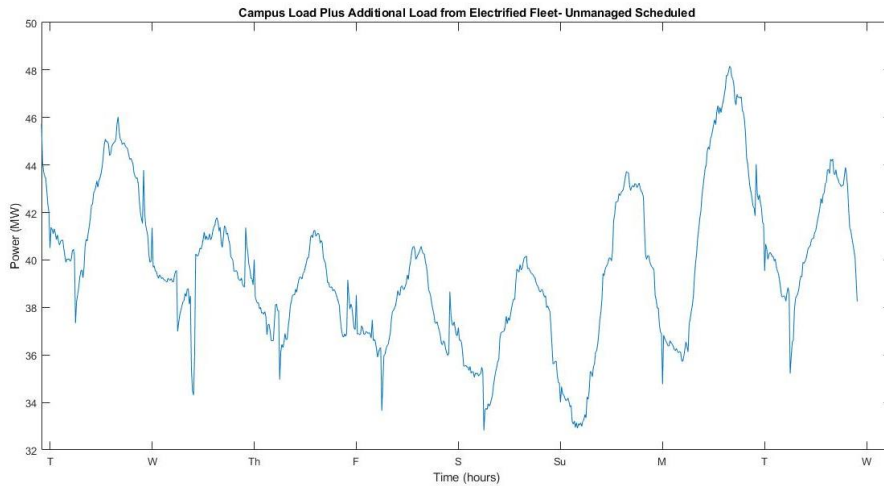

Figure 5.6. Total Load for Unmanaged Scheduled Charging

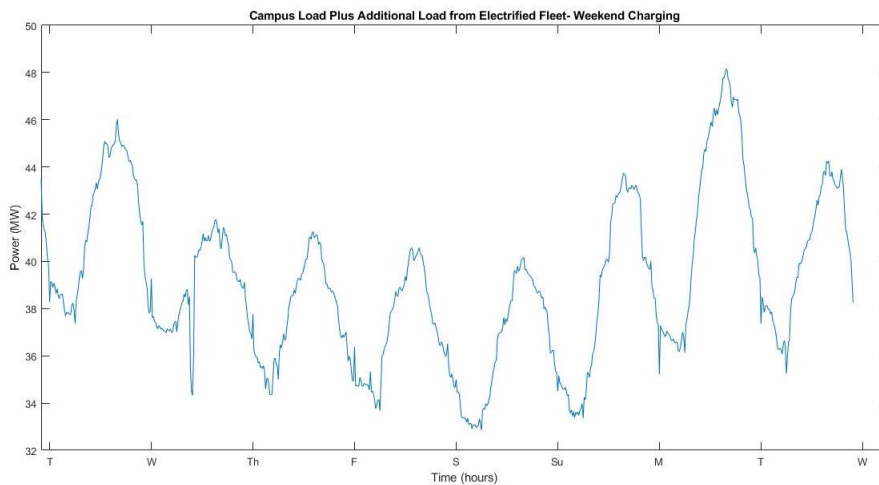

Figure 5.7. Total Load for Weekend Charging

The unmanaged, scheduled scenario has the largest peak power of about 2.7 MW on Monday night, which is the first day of the cycle. This is represented in Figure 5.6 the 45 MW peak which occurs near the y-axis. Besides the initial 45 MW peak, the other larger peaks shown in the figure are from the existing campus load rather than from the electrified fleet since they all occur in the afternoon, but charging occurs at night. Therefore, the smaller spikes are mostly due to electrified fleet load. The unmanaged, unscheduled scenario reaches the 2nd largest peak power

on Monday of about 1.7 MW. Weekend charging, charging every other weekday, charging every day, and managed scheduled charging all require around 0.5 MW of power each day maximum. Figure 5.7 shows the total campus load including electrified fleet charging for the weekend charging scenario. It is similar to Figure 5.6 since both load profiles are dominated by the existing campus load. However, among close inspection, the spikes between peaks are smaller in the weekend charging scenario due to lower power requirements for charging.

The power requirements of an electrified fleet stay below the 5 MW range, which is small in comparison to the 30 to 50 MW usually required for the rest of the campus load. Additionally, charging usually occurs at night while building power requirements are greatest during the day. Therefore, the peak power requirements for electric vehicle charging and for the rest of campus usually do not line up at the same hour. Future technology could perhaps use electric vehicles as storage in a vehicle-to-grid system to shift the overall peak load to off-peak hours. Overall, the UW distribution grid will be able to handle the addition of an electrified fleet, especially if the charging is managed and scheduled.

5.3 RECOMMENDATIONS

Based on the analysis of the energy and power requirements for electrifying the UW Transportation vehicle fleet, UW Transportation should consider the recommendations summarized in Table 5.2 when implementing the ten-year electric vehicle replacement plan.

Table 5.2. Recommendations to UW Transportation for Fleet Electrification

Recommendation	Benefits
Install L2 AC chargers for EVs and PHEVs	Minimal energy and power requirements compared to DC chargers. Faster charging than AC L1 chargers. Less expensive installation than DC chargers. Already existing AC L2 chargers on campus.
Install “smart” chargers with managed charging capabilities	Automated charge initiation and termination. Ability to control charging power based on schedule and energy constraints.
Charge vehicles according to the “charging vehicle every weekday” or “weekend charging” scenario	Low energy, power, cost, and charger requirements. Logistically simple charger swapping for an attendant and vehicle locating for a user.
Expand existing charging infrastructure so that chargers are located in the same parking lots that already contain chargers, or at an adjacent lot	Minimal construction. Convenience of EVs parked among a smaller number of lots, especially when charger swapping is required. Potential for future solar canopy charging stations since vehicles are arranged in clusters.
Electrify as many fleet vehicles as possible. If new EV models arise that are an appropriate replacement for vehicles which currently do not have a suitable replacement option, make sure to replace those vehicles with EVs as soon as possible	Lower long-term costs for EVs vs ICEs. Environmentally beneficial to electrify vehicles and reduce greenhouse gas emissions. Ability to achieve goals in UW’s sustainability action plan.

5.4 FUTURE WORK

This thesis work uses a data-driven approach to inform UW Transportation on the most energy, power, infrastructure, and cost-effective methods for electrifying the vehicle fleet. It is an attempt to narrow the options for charging schemes made under assumptions justified by quantitative data and user feedback. UW Transportation can follow the recommendations of this thesis with the confidence that these recommendations are supported by data provided by UW Transportation itself, UW Facilities, UW Solar, and other reputable sources. While this thesis provides details for typical fleet vehicle use cases, further work can be done to consider edge cases as well as perform a more detailed analysis for the most promising results.

One consideration that was not addressed in the thesis work but was incorporated into the ENGINE capstone project is using DC chargers for vehicles with high power and energy requirements. In UW Transportation's vehicle replacement plan, vehicles such as large shuttles or trucks are not replaced with EVs or PHEVs. Electric replacements for these vehicles could only be reasonably charged using DC fast chargers. Therefore, UW Transportation could consider purchasing EV replacements for these vehicles and DC fast chargers to accommodate them. While DC fast chargers have the benefit of quick charging, this means that they use far more power (often ten times more) than AC L2 chargers [11]. Additionally, their installation is much more expensive. UW Transportation would have to install DC fast chargers only when necessary and would need to be strategic about when and where they are used to avoid overloading the campus electrical grid.

Another opportunity for future work is the analysis of public charging on campus. Public chargers already exist on campus. Since they are not used for the UW Transportation fleet, they were not considered within the scope of this thesis. UW can take advantage of using fleet chargers for public charging as an additional revenue stream and a way to encourage commuting by EV or PHEV. In some of the scenarios analyzed for this project, there are chargers which are not used every day. These chargers could be used for off-peak public charging when they are not being used for UW fleet vehicles. Additionally, commuters who wish to charge during the day while they are in class or working on campus could charge during peak hours since that is when the UW fleet vehicles are usually not charging. While these options would not require additional charging infrastructure, they would require additional energy and power. If UW was to increase public charging, it would have to be aware of the additional energy and power this would entail and confirm that the grid would not be overloaded, especially if people are charging during peak hours.

As mentioned in Section 5.2, UW Solar is working with UW Transportation to install a solar canopy over the E1 parking lot and chargers under the canopy. The idea of this installation is to add electricity generation to campus that will help offset the increase total daily energy requirements due to electric vehicle charging. Such an addition would make charging during peak hours more feasible since solar power is most abundant during the daytime. Once the installation is complete, the E1 lot could be a promising location for fleet chargers that are used as public chargers during peak hours.

In addition to evaluating other charging infrastructure and use options, UW Transportation can do a more in-depth analysis of the most favorable charging scenarios, namely charging every vehicle every weekday and weekend charging. While this thesis work is useful for identifying charging scenarios which would most likely be superior from an energy, power, cost, and infrastructure perspective, the large scope of this project limits the ability to do an extremely in-depth analysis for each scenario. The main assumption in these cases is that vehicles are only used on weekdays. In order to make a more accurate estimate of energy and power requirements, this assumption would no longer be valid. Additionally, vehicle use likely varies with time of year, so it would be helpful to complete separate analysis for different seasons. Additionally, it would be useful to complete a more detailed cost analysis similar to the one done by UW Solar in the Transportation Electrification Plan which includes insurance and incentives.

Furthermore, this work considers only the UW Transportation vehicles located at the Seattle campus in University District. The analysis could be expanded to include the UW Bothell and UW Tacoma campuses. Other UW-owned vehicles which are not usually housed on a campus (such as ones used for Friday Harbor Labs) could be evaluated for electrification feasibility based on the availability of existing nearby chargers.

Similarly, this thesis can be used as an example for other fleet electrification studies. As incentives and climate goals encourage the shift to electrified transportation, organizations such as the University of Washington are electrifying entire fleets of vehicles. To do so in an efficient way with minimal environmental impact, organizations must consider charge management and charge scheduling. Fleet electrification is a necessity for a better environmental future, and thus should be planned with long-term energy and power implications in mind.

BIBLIOGRAPHY

- [1] “Lighting the Path to Net Zero: NREL’s Strategy Drives Deep Transportation Decarbonization.” [Online]. Available: <https://www.nrel.gov/news/program/2021/lighting-the-path-to-net-zero-nrels-research-strategy-drives-deep-transportation-decarbonization.html>
- [2] “UW earns sustainability recognition.” [Online]. Available: <https://green.uw.edu/news/uw-earns-sustainability-recognition>
- [3] “UW Sustainability Action Plan.” [Online]. Available: <https://green.uw.edu/sustainability-plan>
- [4] “Home - Urban Infrastructure Lab,” Urban Infrastructure Lab - Just another HIVE Sites site. [Online]. Available: <https://uil.be.uw.edu/>
- [5] “Bill Information.” [Online]. Available: <https://app.leg.wa.gov/billinfo/>
- [6] “AFLEET Tool - Argonne National Laboratory.” [Online]. Available: <https://afleet.es.anl.gov/home/>
- [7] O. US EPA, “MOVES and Other Mobile Source Emissions Models,” Feb. 12, 2016. [Online]. Available: <https://www.epa.gov/moves>
- [8] O. US EPA, “Plug-in Hybrid Electric Vehicle - Learn More About the New Label,” Oct. 13, 2016. [Online]. Available: <https://www.epa.gov/fueleconomy/plug-hybrid-electric-vehicle-learn-more-about-new-label>
- [9] UW Solar, “UW Transportation Electrification Report.”
- [10] “Vehicle rental (UCAR) | UW Facilities.” [Online]. Available: <https://facilities.uw.edu/catalog/vehicle-rental>
- [11] T. Moloughney, “What Are The Different Levels Of Electric Vehicle Charging?,” Forbes Wheels, Jul. 01, 2021. [Online]. Available: <https://www.forbes.com/wheels/advice/ev-charging-levels/>
- [12] “ENGINE Showcase | UW Department of Electrical & Computer Engineering.” [Online]. Available: <https://www.ece.uw.edu/news-events/capstone-fair/>
- [13] “Protocols, Home - Open Charge Alliance.” [Online]. Available: <https://www.openchargealliance.org/protocols/>

- [14] steve. 2021 [Online]. Available: <https://github.com/RWTH-i5-IDSG/steve>
- [15] H. Chris, “Electric Vehicle Charging” [Online]. Available: http://www.fveaa.org/fb/J1772_386.pdf
- [16] ArduinoOcpp. [Online]. Available: <https://github.com/matth-x/ArduinoOcpp>
- [17] “Project Sunroof.” [Online]. Available: <https://sunroof.withgoogle.com/>
- [18] “HelioScope: Advanced Solar Design Software.” [Online]. Available: <https://www.helioscope.com/>
- [19] “PVWatts Calculator.” [Online]. Available: <https://pvwatts.nrel.gov/>
- [20] UW Solar, “Solar Feasibility Study - E Lots,” Mar. 13, 2020 [Online]. Available: https://docs.google.com/document/d/1_xM0J8adv2U0IdcDchpc9-5iYv-vr0_ADiv2p0CIG_Y/edit#heading=h.oz6p5f1tk36y
- [21] D. Smith, “Business Rates,” City of Seattle. [Online]. Available: <https://www.seattle.gov/city-light/business-solutions/business-billing-and-account-information/business-rates>
- [22] “Hans Rosling Center for Population Health,” Campus Maps. [Online]. Available: <https://www.washington.edu/maps/>
- [23] “How Long Will My EV Battery Last? (and 3 Tips to Help it Last Longer),” The Equation, Mar. 10, 2020. [Online]. Available: <https://blog.ucsusa.org/hanjiro-ambrose/how-long-will-my-ev-battery-last-and-3-tips-to-help-it-last-longer/>
- [24] H. Chris, “Electric Vehicle Ownership Costs: Today’s Electric Vehicles Offer Big Savings for Consumers,” Consumer Reports, Oct. 2020 [Online]. Available: <https://advocacy.consumerreports.org/wp-content/uploads/2020/10/EV-Ownership-Cost-Final-Report-1.pdf>
- [25] “Annual Energy Outlook 2022,” Independent Statistics and Analysis. [Online]. Available: <https://www.eia.gov/outlooks/aeo/data/browser/#/?id=3-AEO2022®ion=1-0&cases=ref2022&start=2032&end=2042&f=A&linechart=ref2022-d011222a.96-3-AEO2022.1-0~---ref2022-d011222a.101-3-AEO2022.1-0&map=ref2022-d011222a.4-3-AEO2022.1-0&ctype=linechart&sourcekey=0>