

Under the Bridge:

Utilizing Covered Liminal Spaces for Formal Homeless
Encampments in the City of Seattle

Maxwell Baker

A thesis submitted in partial fulfillment of the requirements for the degree of
Master of Urban Planning
University of Washington
2016

Committee:

Associate Professor Manish Chalana
Lynne Manzo

Program Authorized to Offer Degree:
Urban Design and Planning

University of Washington

Abstract

Under the Bridge:

Utilizing Covered Liminal Spaces for Formal Homeless Encampments in the City of Seattle

Maxwell Baker

Chair of the Supervisory Committee:

Associate Professor Manish Chalana

Urban Design and Planning

The number of homeless sleeping outside in Seattle has increased significantly in the past few years, from 2,600 in 2012 to 4,500 in 2016. In response, the City has begun to spearhead the development of temporary sanctioned homeless encampments on vacant public land as an innovative alternative to an overburdened emergency shelter system. Vacant land remains a valuable, limited commodity in the rapidly growing Puget Sound region, however, making it difficult for the city to want to remove developable land from its inventory, even if only temporarily. Thus, land beneath and adjacent to rights-of-way presents an option for the placement of homeless encampments that doesn't utilize developable land. Numerous bridges, overpasses, and viaducts are employed in the city's transportation system to overcome physical impediments such as rivers and steep slopes, creating voids or "liminal spaces" in the urban landscape beneath them. This thesis looks to expand upon the City of Seattle's current site selection process for encampments by considering these covered liminal spaces as a viable option. The first section of this document covers the history and policies surrounding homelessness in the United States, while precedent studies examine different ways in which covered liminal spaces have been re-conceptualized as public assets that are either informal, formal, or prototypical in nature. The research study chapter describes the background research, GIS analysis, and field visits that were conducted during the site selection process. A scoring system was developed based upon a site's access to transit, proximity to homeless service centers, and current use, with three sites being ultimately chosen for field visits. Design recommendations and vignettes are subsequently presented for each site. In the end, expansion of the City of Seattle's encampment site-selection process to include covered liminal spaces offers up a significant amount of practicable underutilized land within the city for hosting the homeless while simultaneously improving otherwise discounted urban spaces.



Figure 0.1: I-5 Colonnade Park. Source: Max Baker

Table of Contents

List of Images/Tables.....	6
Introduction.....	8
Critical Stance.....	11
Chapter 1: Issues of Homelessness	14
State of Homelessness	16
Reactions to Homelessness.....	26
Chapter 2: Homeless Encampments	36
Encampment Qualities	38
Chapter 3: Liminal Spaces	48
Urban Liminal Spaces	50
Liminal Space Precedents.....	56
Chapter 4: Encampment Research Study	70
Seattle Siting Process	72
Proposed Siting Process.....	78
Current Encampment Sites.....	86
Potential Encampment Sites	94
Results	119
Chapter 5: Site Visits and Conclusion.....	124
Site Visits	126
Discussion and Conclusion.....	141
Works Cited.....	145
Appendix.....	155

List of Images/Tables

Figure 0.1:	I-5 Colonnade Park. Source: Max Baker
Figure 0.2:	I-5 in Seattle. Source: Max Baker
Figure 1.1:	Hooverville, Seattle, 1933. Source: University of Washington Libraries. Special Collections Division. Color by Paul Edwards.
Figure 1.2:	Guangzhou Overpass. Source: China / Caters News
Figure 1.3:	A bench in Vienna. Source: Herzi Pinki / CC BY-SA 4.0
Figure 2.1:	Othello Tiny Homes. Source: Max Baker
Figure 3.1:	Ship Canal Bridge. Source: Max Baker
Figure 3.2:	Brooklyn-Queens Expressway. Source: MusikAnimal, Wikimedia Commons
Figure 3.3:	Embarcadero Viadcut. Source: Bronson, William. <i>How to Kill a Golden State</i> . 1st Ed.]. ed. Garden City, N.Y.: Doubleday, 1968. Print
Figure 3.4:	Alaskan Way Viadcut. Source: Google
Figure 3.5:	Green Lake Boulevard. Source: Max Baker
Figure 3.6:	Green Lake Park and Ride. Source: Max Baker
Figure 3.7:	Aurora Bridge. Source: Max Baker
Figure 3.8:	Aerial, Jakarta Living Bridge. Source: Google
Figure 3.9:	Jakarta Living Bridge. Source: Sanja Jovanovich / Global Post
Figure 3.10:	Aerial, School Under the Bridge. Source: Google
Figure 3.11:	School Under the Bridge. Source: Altaf Qadri / AP
Figure 3.12:	Aerial, Bajo Puentes Site. Source: Google
Figure 3.13:	Bajo Puentes space. Source: Dominic Bracco II / Prime
Figure 3.14:	Aerial, Kwun Tong Bridge Site. Source: Google
Figure 3.15:	East Kowloon Office. Source: HKSAR Government
Figure 3.16:	Aerial, I-405 Overpass, Portland. Source: Google
Figure 3.17:	Unclouded Vision. Source: Opsi Architecture. aiaportland.org
Figure 4.1:	Othello Encampment Construction. Source: Ken Lambert. Beekman, Daniel. "Seattle mayor picks Rainier Valley for 3rd homeless camp." <i>Seattle Times</i> . February 26 2016.
Figure 4.2:	Author volunteering with LIHI. Source: Osato Cooley
Figure 4.3:	Current Seattle Encampment Sites
Figure 4.4:	Ballard Encampment. Source: Low Income Housing Institute, lihi.org
Figure 4.5:	Interbay Encampment. Source: Low Income Housing Institute, lihi.org
Figure 4.6:	Tiny House Village. Source: Low Income Housing Institute, lihi.org
Figure 4.7:	Othello Encampment. Source: Low Income Housing Institute, lihi.org
Figure 4.8:	Liminal Space Inventory
Figure 4.9:	Potential Liminal Space Encampment Sites
Figure 4.10:	Green Lake Park and Ride Sites Map
Figure 4.11:	Ballard Bridge Sites Map
Figure 4.12:	Fremont Bridge Sites Map
Figure 4.13:	Portage Bay Region Sites Map
Figure 4.14:	Magnolia Bridge Sites Map
Figure 4.15:	I-5 Colonnades Site Map
Figure 4.16:	I-5 Cherry Street Sites Map
Figure 4.17:	I-5 International District Sites Map
Figure 4.18:	I-90 Interchange Sites Map
Figure 4.19:	Spokane Street Viaduct Map
Figure 4.20:	Fauntleroy Expressway Map
Figure 5.1:	I-5 Colonnade Park. Source: Max Baker
Figure 5.2:	Recording noise levels. Source: Max Baker
Figure 5.3:	Sound Pressure Level Chart. Source: Occupational Safety and Health Administration, https://www.osha.gov/dts/osta/otm/noise/health_effects/soundpropagation.html
Figure 5.4:	Recommended encampment structures based on decibel levels
Figure 5.5:	Cherry Street Parking Lot Aerial. Source: Google
Figure 5.6:	Cherry Street Parking Lot. Source: Max Baker
Figure 5.7:	Cherry Street Parking Lot Rendering. Source: Max Baker
Figure 5.8:	Portage Bay Site 1 Aerial. Source: Google
Figure 5.9:	Portage Bay Site 1. Source: Max Baker
Figure 5.10:	Portage Bay Site 1 Rendering. Source: Max Baker
Figure 5.11:	Ballard Bridge North Site Aerial. Source: Google
Figure 5.12:	Ballard Bridge North Site. Source: Max Baker
Figure 5.13:	Ballard Bridge Rendering. Source: Max Baker
Table 1:	One Night Count Results, 2006 - 2015. Source: King County 2015 One Night Count
Table 2:	Summary of the 2016 Unsheltered Homeless Count. Source: King County 2016 One Night Count



Figure 0.2: I-5 in Seattle. Source: Max Baker

Introduction

Homelessness has existed to some degree throughout the history of the United States, but saw a marked rise following the Great Recession of 2008/2009. The resulting unemployment and foreclosures worked to push many individuals and families to the edge of financial security or past it. The dwindling number of subsidized rental units due to government funding cuts over the past few decades have effectively reduced the housing safety net for many people as well. The Department of Housing and Urban Development's HOME program, which distributes block grants to states and communities for assisting low-income renters and homeowners, had its budget slashed in half from \$1.8 billion to \$900 million between 2010 and 2015 alone (Hoag). In 2014, the total amount of funding for homelessness alleviation programs at HUD totaled just \$2.1 billion (National Alliance to End Homelessness).

The issue of homelessness has become a particular cause for concern for America's urban regions. Beginning in 1982, the U.S. Conference of Mayors and the U.S. Conference of City Human Services Officials brought to light the lack of emergency services in urban areas, and has since then attempted to underscore the need for affordable housing to combat homelessness (US Conf. of Mayors). Local government responses to homelessness vary widely however, ranging from progressive approaches such as the provision of services like soup kitchens and transitional housing, to the regressive, such as homeless encampment sweeps by law enforcement.

In the city of Seattle, homelessness continues to increase while the rate for Washington state decreases overall. Since 2007, the total homeless population in the region has swollen from 7,902 to 10,122, with the unsheltered population nearly doubling (HUD, 2015 CoC). The city of Seattle and King County enacted separate States of Emergency in 2015, and various short and long-term measures continue to be rolled out in an attempt to address the needs of the growing homeless population. Though regional leaders have made promises to fully address this crisis, many efforts continue to fall short of providing solutions for everyone in need, with lack of funding, challenging political processes, red tape, and remonstrations from city residents and property owners providing just a few of the causes. While nonprofits and religious organizations have attempted to fill the gaps in service delivery, they are often overwhelmed by demand. Shelters are often at or beyond capacity, all the while rising rents and home prices continue to push people out of homes across the city.

In working to develop cost-effective, interim solutions to the homeless crisis, the City of Seattle has decided to allow sanctioned homeless encampments run by non-profits to operate on publically owned land. Three such camps have been developed within the last year, dispersed evenly across the city. Additional encampments have also been permitted on religious properties as well. While this innovative approach is a commendable first step by the City, the site selection process is significantly hindered by the limited amount of vacant land within the city. A total of only six City parcels were ultimately deemed feasible for hosting the three encampments.

In working to expand upon this inventory, I looked to areas of the city that are often overlooked; the “liminal spaces” of the urban landscape. Expressly, covered liminal spaces are those areas beneath the city’s bridges and overpasses that often remain underutilized. Such locations exist all across Seattle, having emerged in tandem with the highways, viaducts and bridges that cross and connect the region. They range from the minute to the expansive, in some cases taking up entire city blocks. These sites do not show up in the City’s current locational process, providing new and uncharted options for the potential siting of homeless encampments.

Audience

This thesis is intended to be read by city planners and council members who deal specifically with municipally-sanctioned homeless encampments, non-profits that help to organize and operate the city’s these camps, urban designers who are looking to develop innovative solutions to the Seattle housing crisis, and potential encampment residents themselves. It works to analyze the City’s current site selection process while offering an improved, alternative approach. Additional site inventories are developed that identify previously unconsidered areas for encampment employment. Case studies present examples of other projects that have attempted to utilize cities’ liminal spaces in new and worthwhile ways, while the final site selection process and field visits offer detailed evaluations of potential locations.

Thesis Chapter Organization

Chapter One provides background information on the current state of homelessness in the United States. This section is broken into four subsections: The Great Recession(s) and Homelessness, Affordability and Homelessness, Federal Funding/Subsidized Housing and Homelessness, and Seattle and King County State of Homelessness. These subsections together look to expose the origins of the modern homelessness

emergency and the ways in which it is currently playing out in Seattle and the greater Puget Sound region.

Chapter Two covers the potential benefits and shortcomings of sanctioned homeless encampments. Their cost-effectiveness, safety, adaptability and ability to serve residents' needs are all examined in-depth. Comparisons to other forms of shelter are provided, drawn from both Seattle and other cities.

Chapter Three introduces the concept of "liminal spaces", providing different schools of thought concerning these urban elements. A general history of bridges and overpasses in modern American cities is outlined, followed by recent examples of infrastructure projects that have generated significant liminal space in various cities, including Seattle. Liminal Space Precedents provide examples of projects that have worked to address and improve such spaces that go beyond the creation of public parks and/or artwork. These cases studies range from the informal to the prototypical, as well as regional to international.

Chapter Four, Encampment Research Study, details my research methodology. The first section analyzes the City of Seattle's current encampment site location process and extricates any information that could be applied to my personal study. The next section, Proposed Siting Process, sets forth the proposed site selection and scoring scheme. An inventory of the city's covered liminal spaces is summarized, followed by subsequent rounds of omission that work to narrow the number of sites down to those that are most reasonable for hosting an encampment. Each of these remaining sites is then scored and ranked using the developed scoring scheme.

Chapter Five pulls three of the higher scoring sites for field visits in order to ground-truth findings from the earlier analysis. Issues surrounding access, current use and noise are detailed, with shelter design recommendations created dependent upon findings. Concept renderings showcasing potential redevelopment schemes are included, with conclusions and reflections on the site selection experience following. Any shortcomings are noted, and potential next steps set forth.

Critical Stance

It is my belief that as urban planners and designers, issues surrounding equity and its progression should be held up as some of our greatest concerns. As Cleveland's former planning director Norman Krumholz has said, "Equity requires that government institutions give priority attention to the goal of promoting a wider range of choices for those residents who have few, if any, choices" (Krumholz). It is for this reason that I chose to focus on the procurement of homeless encampments in Seattle, WA, an innovative form of urban design that works to better address the needs of the city's disenfranchised groups.

In seeking to understand the effectiveness of sanctioned homeless encampments in accommodating the homeless, my focus initially began with the successes and shortcomings of Seattle's current encampment location process. In doing so, I surmised that the exploration of permanently underutilized land would likely present better options for locating and placing new homeless encampments than the vacant city-owned lots that are currently being used. This led to my inventorying, analyzing, and exploring underutilized spaces beneath the city's transportation infrastructure, i.e. its bridges and highway overpasses.

The following questions were subsequently developed:

- What, if any, site considerations influence the City of Seattle's homeless encampment siting process?
- How may the city's site selection process be improved to better reflect the needs of the homeless?
- Which covered liminal spaces would function best to host homeless encampments, and how do they compare to the City's current encampment locations?
- How might covered liminal spaces be re-conceptualized as providers of shelter?

The city of Seattle and its residents have always prided themselves on innovative urban design approaches that look to recapture and improve those city spaces that would otherwise be considered unflattering to the public. Some examples include the Fremont Troll carving beneath the Aurora Bridge, the Colonnade mountain bike park

beneath Interstate 5 downtown, and Gasworks Park, a former industrial site turned world-renowned waterfront park. Such creative projects continue to be explored across the city as unprecedented growth and limited land force designers to become resourceful with what remains available.

While such innovative design endeavors are worthy of praise, it is unfortunate that little to no effort has been put forth in developing projects that work to accomplish more than one goal at a time, in this case the provision of housing for the homeless and the improvement of underutilized covered spaces. Attempting to employ every covered urban space for the development of either a park or art project is not necessarily the most effective tactic, and in many cases can lead to the displacement of individuals who are forced to use these spaces as a last-resort form of shelter.

I also believe that sanctioned homeless encampments play an important role in addressing what should be considered nothing less than a public health crisis. At least 91 homeless people died in 2015 alone, 27 more than the year before (Beekman, "Mayor, County Exec"). The current shelter system is perpetually failing Seattle's homeless population, and no end to the crisis is currently in site. Every possibility for housing the city's homeless, especially those approaches that aren't exceedingly cost-prohibitive or difficult to quickly implement, should be pursued. This makes sanctioned homeless encampments one of the best interim shelter options that currently exists. By looking to re-conceptualize covered liminal spaces as sites for new encampments, planners and designers may better work towards the creation of truly healthy and safe communities.

Chapter 1

Issues of Homelessness



Figure 1.1 :Hooverville, Seattle, 1933: Source: University of Washington Libraries. Special Collections Division. Color by Paul Edwards.

State of Homelessness

Homelessness is inextricably linked with the history of the Americas, its origins tracing back to English colonialism. The earliest recorded mention of homeless individuals was in 1640s Boston when “vagrant persons” were listed as some of the social outcasts that officers of the peace were to be charged with apprehending (Kusmer). As time has passed, the issue of homelessness has ebbed and flowed with the progression of the country. Wars, famine, economic recession and expansion, technological progression and political programs have all contributed to or partially alleviated homelessness through the centuries. It has been found that two of the more significant predictors of homelessness are the severity of economic recessions and the affordability of cities.

The Great Recession(s) and Homelessness

Leading up to and through a national recession, homelessness rates usually see a dramatic spike due to increased unemployment, added personal debt, and strained government resources. During the Great Depression, the worst recession in the history of the United States, unemployment soared to nearly 25% in 1933 (“Unemployment Stats of Great Depression”). Roughly 1,000 home loans were being placed into foreclosure each day during that time, and hundreds of thousands of Americans found themselves sharing a home with relatives or forced to live on the streets (Streissguth). It was during this time that Hoovervilles were produced, veritable villages within cities that housed hundreds, if not thousands of unemployed individuals and families (Fig. 1.1). One of the country’s largest Hoovervilles existed right within the borders of Seattle, housing over 1,000 unemployed workers near the city’s waterfront between 1931 and 1941 (Demirel).

Homelessness has continued to wax and wane with the flows of the national economy. The U.S. Census Bureau’s 2012 report *Income, Poverty, and Health Insurance Coverage in the United States* showcases the increases and decreases in poverty rates among the population in the context of recent national recessions. The largest spikes in poverty took place during the recessions of the early 1980s and the late 2000s, events that led to significant increases in unemployment and homelessness (DeNavas-Walt). It should also be noted that the effects of an economic downturn often continue to impact those closest to the poverty line long after the official culmination of a recession, with continuing decreases in wealth for the lowest earners for some time after (AP).

It should come as no surprise that the 2007-2009 downturn, known as the “Great Recession,” saw a marked increase in poverty rates and in turn homelessness. This event was the single greatest economic collapse since the Great Depression, with the national unemployment rate doubling from 5% in 2008 to 10% in 2009 (Fred Database-Unemployed). Stock market prices fell by nearly 57% between 2007 and 2009, from 1,565 to 676 (Fred Database-S&P 500 Index). Foreclosure starts increased fourfold during the recession, a spike much larger than any increase observed in the three other recessions since the start of the data series in 1980 (Ellen, 2).

According to the National Alliance to End Homelessness, homelessness increased approximately three percent, or by 20,000 people, between 2008 and 2009 (Cauvin). The increase in the number of homeless families was even greater, at four percent. This increase came on the heels of a steady decrease in homelessness through the early 2000s, undoing much of the progress that had been made during that time. Thirty-two states including Washington D.C. recorded increases, reflecting the national concern generated by the recession (Cauvin).

As we move into 2016 and further out of the Great Recession, homelessness rates have been decreasing steadily across the country. The NAEH estimated that the number of people experiencing homelessness in America decreased by 2.3 percent from 2013 to 2014. While these numbers are encouraging, it should be noted that there still exist 578,424 known homeless individuals in the United States, roughly equivalent to the population of Seattle in 2005. Of these, 177,173 or one third of the total remain unsheltered, indicating that these people are “living in a place unfit for human habitation, such as on the street, in a car, or in an abandoned building” (NAEH 16).

Affordability and Homelessness

While the NAEH’s report reflects a general trend of declining homelessness, levels remain variable by location. While the national rate of homelessness stood at about 18.3 people per 10,000 residents, a number of states recorded well above this average. For example, Washington D.C.’s rate stood at 119.9 homeless per 10,000 residents, while the state of Washington’s was 26.5 (NAEH, 13). Rates increased in the following 12 states between 2013 and 2014: Washington, Idaho, Nevada, Colorado, Nebraska, Minnesota, Iowa, Michigan, Pennsylvania, New York, Vermont, and Massachusetts (13). The remaining states’ rates either stayed flat or declined. This shows that while homelessness remains an issue of national importance, it often plays out in different ways at the regional level.

One of the great issues impacting this variability is that of housing affordability. Rental and homeownership costs differ significantly between cities and states, impacting low-income populations in various ways. In the United States we use a standard housing burden of 30% to signify what is and isn't affordable for a tenant. This standard has its origins in the United States National Housing Act of 1937, which dictated that eligibility for public housing was dependent upon a family's income and could not exceed five to six times the rent (US Census Bureau). This income limit gave way to the maximum rent standard, in which rent could not exceed 20 percent of income. The Brooke Amendment to the 1968 Housing and Urban Development Act raised this threshold to 25 percent to increase funding for public housing maintenance and construction needs, and was again raised to 30 percent in 1981, the standard that the U.S. Department of Housing and Urban Development uses today (2). The thirty percent standard has come under scrutiny over time, with opponents contending that it is an arbitrary measure of affordability. Such a flat standard affects households of dissimilar income levels differently, and often does not take into account the various additional needs that an individual or family may have. Michael Stone, a University of Massachusetts researcher, purports that family households are impacted to a greater degree than those without children, though the 30 percent standard is applied regardless. "Families with two incomes and no children can spend more on housing than those with kids, which have to pay more for everything from clothes to day care" (Weise). Higher-income groups are able to absorb the costs of a flat rate more easily than that of low-income groups, for they will have more remaining afterwards to take care of their other basic needs. It is for this reason that housing affordability measures often fall short of reflecting the true needs of low-income households. In turn, the true burden of housing cost on low-income households is often greater than many would expect it be.

Over the past few years, household income has increased at a slower rate than the cost of housing. In 2012 the median household income actually saw a decrease of 1.5 percent to \$50,054, lower than the median for 1995 (Rosenberg). Since then wages have gone up marginally, while housing prices have skyrocketed. Between the first quarter of 2012 and the second quarter of 2015, housing prices in the United States have increased an average of 13.8 percent ("American House Prices"). In Seattle this change has been even greater, with a 30.1 percent increase during the same period. The ratio of home prices has increased significantly for the city as well, climbing from 4.1 in 2012 to 5.0 in 2015 ("American House Prices"). Needless to say, this increase has worked to impact lower-income tenants, pushing them further to the edge of financial security.

Recent research has begun to overwhelmingly support the idea that homelessness is directly related to a lack of affordable housing within a municipality. According to a study completed by June Ying Shann-Hwa Park of Columbia University's Department of Economics, "Places and time periods with higher homelessness rates definitely have fewer vacancies in the low rent sector, making it more difficult for low-income households to secure housing" (Park 93). Following an even more critical examination of the market in New York City, the study held that "the relationship between housing and homelessness in New York City over time, there is a statistically significant negative correlation between the number of homeless households and vacant low rent housing units which emerges. In New York City, tighter housing market conditions occurred while homelessness was rising. Therefore, the previous cross-sectional finding that areas with higher homeless rates had tighter housing market conditions is consistent with the research here across space and time, if in time we are focusing on a single housing market" (Park 93).

According to a 2013 study by the Journal for Urban Affairs, an increase in the median rent of \$100 for a city in the United States is linked to a 15% increase in homelessness (Byrne). Seattle's rent went up by \$113 between 2010 and 2013, the highest of any major American city (Balk). This increase combined with a tight housing inventory has worked to push many tenants out of their rental units. Such findings provide a significant case for the creation of affordable housing within urban areas, and the consequences for those on the edge of homelessness when such stock is lacking.

It should be noted that the City of Seattle is attempting to address issues surrounding affordability through the development of the Housing Affordability and Livability Agenda, a 65 part plan developed by an advisory board consisting of affordable housing advocates, developers, land-use experts, tenants, businesses and nonprofits. Mayor Ed Murray outlines HALA as "a multi-pronged approach that calls for innovative changes in how Seattle plans and accommodates housing, as well as a shared commitment between taxpayers, businesses and nonprofits to support the construction and preservation of affordable housing" (City of Seattle 1). The end goal is the development of 50,000 new units in the city, 20,000 of which will be designated affordable (1). It also looks to double the Seattle Housing Levy to \$290 million, a funding mechanism that is meant to create affordable housing with services to support at-risk families, seniors and people with disabilities, preserve housing to prevent displacement of long-term residents, and to provide rental assistance to prevent homelessness (3). While the recommendations put forth by the board are commendable in their attempts to increase housing stock, stabilize rental rates and

prevent increases in the number of homeless, it does not mention any tactics to move those who are currently homeless into formal housing units. Additional plans will likely need to be conceived moving forward to accommodate those who currently go without shelter.

Federal Funding/Subsidized Housing and Homelessness

Another issue that contributes to the plight of the homeless is the dwindling amount of government resources that are allocated to fund homelessness programs and subsidized housing within the United States. The modern sphere of governmental assistance stems largely from federal programs that were enacted during the great depression and have been amended, restructured, or terminated since then. President Franklin D Roosevelt's New Deal program enacted in 1933 worked to establish assistance programs for disenfranchised Americans while creating new government agencies to more directly handle issues produced by the economic recession. One of these major issues was the lack of quality, affordable housing for the country's lower and middle income residents, which led to the formation of the 1934 National Housing Act, and in turn the Federal Housing Administration (FHA).

The FHA was created to stabilize the mortgage industry during the Great Depression by providing mortgage insurance on loans made by FHA-approved lenders throughout the United States (HUD-FHA). A second act was passed in 1937 and led to the creation of the United States Housing Authority (USHA). This act was created "to provide financial assistance to the States and political subdivisions thereof for the elimination of unsafe and insanitary housing conditions, for the eradication of slums, for provision of decent, safe, and sanitary dwellings for families of low income, and for the reduction of unemployment and the stimulation of business activity, to create a United States Housing Authority, and for other purposes" (US Housing Act 1937). While certain aspects of this act were controversial, i.e. defining and clearing "slums," it provided unprecedented governmental support in creating housing for low/no-income Americans. The USHA continued its efforts through World War II, after which it was eliminated and replaced by the Housing and Home Finance Agency in 1947.

President Harry Truman ratified the 1949 Housing Act shortly after the creation of the Housing and Home Finance Agency which included legislation reestablishing a public housing program authorizing long-term funding for a total of 810,000 additional units, known as Title III (Bratt). However, it should be noted that the act also included a section known as Title I, which provided funding for large-scale urban renewal

programs in city centers. Many of the targeted urban areas were traditionally home to low-income and minority populations, many of whom were displaced and relocated into new public housing developments. For this reason, it is unknown just how effective the creation of additional public units was at the time, for many residents were not new but instead only relocated from elsewhere. Despite its shortcomings, the act and its later iterations managed to enhance and protect public funding for low-income housing through the 1970s.

The most significant blow to low-income citizens and the homeless came in the early 1980s following the election of Ronald Reagan and the country's shift to a more conservative, hardline attitude around housing and social issues. "Spending on direct aid to cities, including general revenue sharing, urban mass transit, public service jobs and job training, compensatory education, social service block grants, local public works, economic development assistance, and urban development action grants, was sharply cut during the Reagan and Bush administrations" (Lawson). Federal funding for city budgets dropped from 18 percent to 6.4 percent between 1980 and 1990. Between 1978 and 1983 the HUD budget dropped from \$83 to \$18 billion in constant dollars, and a serious decline in the number of new units built reflected such cuts (Hellegers 10). Homelessness rates spiked dramatically during this time as low-rent housing supply dwindled, poverty increased, and the deinstitutionalization of mentally unstable individuals occurred in tandem (Baumohl). This increase in homelessness forced the ratification of the McKinney-Vento Homeless Assistance Act of 1987, which largely established funding mechanisms for the homeless shelter system that the United States continues to rely upon today. The law's goals as described within are:

- To establish an Interagency Council on the Homeless.
- To use public resources and programs in a more coordinated manner to meet the critically urgent needs of the homeless of the Nation.
- To provide funds for programs to assist the homeless, with special emphasis on elderly persons, handicapped persons, families with children, Native Americans, and veterans (Baumohl).

As public and subsidized housing funding has dwindled since its peak in the mid 20th century, so too has funding for homelessness. Between 1995 and 2006, the share of the U.S. budget allocated to Homeless Assistance Grants declined by 28% (NCH). In 1996, funding for McKinney-Vento programs was cut by 27%, with some being eliminated entirely. These included the Adult Education for the Homeless program, the Homeless Veterans Reintegration Project, the Emergency Community Services

Homeless Grant Program, and the Family Support Centers. As of 2015 the HEARTH program, McKinney-Vento’s modern form, is funded at \$2.480 billion, marginally above 1996 levels but still far below its pre-cut peak (FY 2016). The National Alliance to End Homelessness sees this increase as an encouraging step, but still falls short of the demand. “(The increased funding) should be enough to cover all Continuum of Care renewals from FY 2014 grants and will allow communities to continue to expand their rapid re-housing and prevention efforts. In part due to expiring multi-year grants, it unfortunately will not, however, allow us to expand permanent supportive housing capacity” (FY 2016).

Seattle and King County State of Homelessness

Table 1: One Night Count Results, 2006-2015

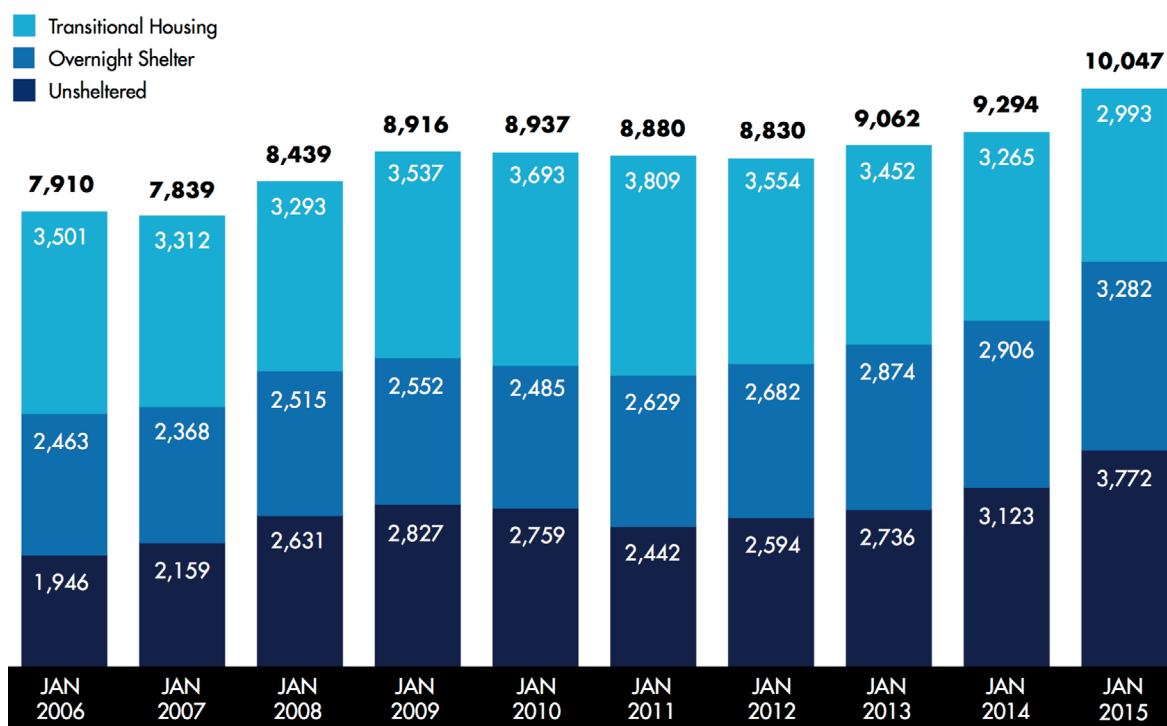

SOURCE: Seattle/King County Coalition on Homelessness

Homelessness in the Puget Sound area is an increasingly serious issue as rents and home prices continue to rise and federal and state funding for affordable housing falls well below the need. While the national rate of homelessness has been declining in recent years, Seattle and King County have recorded steadily growing numbers (Table 1). The 2016 Homeless One Night Count conducted by the Seattle/King County Coalition on Homelessness documented 4,505 unsheltered people within county borders, a 19% increase from the 3,772 that were counted in 2015 (“2016 Street Count Results”). The unsheltered proportion of the count, i.e. those who aren’t found within

emergency shelters or transitional housing, usually accounts for around one third of the total population without housing, making for a potential total homeless population of over 10,000 individuals in 2016. It should also be noted that the One Night Count does not capture the entirety of the homeless population due to issues surrounding access into some areas and the fact that some individuals work diligently to go unnoticed.

While the One Night Count's unsheltered results provide little to no information on the demographics of the population living outside, the results of the tallies taken indoors do. In 2015, a total of 4,197 households were recorded utilizing either an overnight shelter or transitional housing. Of these, 969 were households containing children. This equates to 3,046 or just under half of all homeless individuals as belonging to a "family with children," the significant majority of which were utilizing transitional housing. The next largest group was Single Adult Men at 2,372, followed by Single Adult Women at 836, and Unaccompanied Minors at 19 (Seattle/KC Coalition on Homelessness).

Due to this significant increase in homelessness, the city of Seattle and King County called two separate states of emergency in November 2015 to address the needs of those homeless individuals who are most at-risk. The states of emergency were intended to provide "more administrative authority and flexibility in contracting for services and distributing resources" as described by Seattle Mayor Ed Murray. An estimated \$5 million in city funds were allocated to pay for 100 additional shelter beds, increased prevention and outreach programs, and a van to deliver goods and services to those on the streets. The county proposed an additional \$2 million in funding to create 50 beds, provide 20 housing vouchers for people exiting drug court, and to increase incentives for landlords to rent apartments to homeless veterans (Beekman, "Mayor, County Exec").

As part of Mayor Murray's 2015 Proclamation of Civil Emergency, an expansion to the number of sanctioned encampments on City of Seattle owned land was introduced as well. Legislation allowing for the sanctioned encampment use-permits had been established just a few months earlier with the passing of Ordinance 124747, the first of its type in the city's history. This ordinance adopted a new regulation in the Seattle Land Use Code authorizing interim use permits for a one-year term with an option to extend to two years. The city's decision to allow for the creation of encampments was due to the growing understanding of their role in fighting homelessness: "While an encampment should not become a substitute for safe, affordable permanent housing, an encampment is a viable interim shelter option that can provide community, safety, and dignity in people's lives, when compared with other options such as living on

the streets” (Seattle DPD). The city’s estimated 1,600 shelter beds are obviously not enough to address the entirety of the growing homeless population, and any remaining safety nets are lacking as well. “Although efforts continue to provide low-income housing and managed temporary spaces in churches and public buildings, such resources are currently inadequate to meet the needs of all homeless persons and are not likely to address the needs of all homeless persons in the near future. Temporary shelters are typically available only during the worst environmental conditions including snowstorms and freezing weather” (Seattle DPD). Thus in 2015, the City of Seattle began its first ever effort to identify public lands on which to accommodate homeless encampments.



Figure 1.2: Guangzhou Overpass: Source: China / Caters News



Figure 1.3: A bench in Vienna: Source: Herzi Pinki/CC BY-SA 4.0

Reactions to Homelessness

Rates of homelessness tend to be higher in American cities vs. rural communities; according to the Homelessness Research Institute, major cities had a rate of 43 homeless people per 10,000 residents, compared with 29 people per 10,000 for all urban places and 22 people per 10,000 nationally in 2007 (Henry). Roughly three quarters of the homeless population in the United States congregate in areas deemed completely urban, while sixty percent live in metropolitan areas of greater than one million people (Henry 6). In response, cities have developed various approaches that have the effect of either accommodating, marginalizing, or forcing out their homeless populations.

Public Perception

Much of the American public recognizes homelessness as a significant issue in the country, and supports programs that work towards its eradication. A 2011 poll completed by the City of Chicago found that 4 out of every 5 residents believe housing is a right and support programs that work to prevent homelessness and move families into housing units (ICPH). Over half of these same respondents said that they would be willing to pay more taxes to fund programs to end homelessness. However, the public's perception of the homeless population is often skewed and out of alignment with a number of realities which can result in potentially harmful consequences.

A Gallup poll was conducted in 2007 across eight major cities to gain an understanding of Americans' perceptions on issues surrounding the current state of homelessness. When questioned as to what they thought the primary cause of homelessness is in the United States, over a quarter of the respondents stated that drug or alcohol abuse was to blame, followed by mental illness/disability/post-traumatic stress disorder (Gallup Inc.). Lack of affordable housing was the second least cited reason (4% of respondents), followed by laziness (3%). A similar survey completed in Los Angeles returned significantly more skewed results, with 91% of residents claiming that alcohol and drugs were likely the main reason a person becomes homeless. Eighty-five percent of residents also claimed that mental illness was likely a contributing factor.

These results show a disconnect between what homeless people themselves identify as the cause of their homelessness and what others consider to be the cause. While

the Los Angeles poll returned high numbers of citizen responses attributing substance abuse and mental health to the issue, a survey of the city's homeless population found that around 41% identified drugs and/or alcohol as being a contributing factor, and only 24% as being diagnosed with a mental disorder (Agans 5943). This disconnect is also reflected in the public's understanding of the makeup of the homeless population. Over three quarters of those surveyed in the Gallup poll believe the homeless population to be largely composed of individuals rather than split between families, when in fact nearly 37% of homeless people were members of a family in 2014 (Agans 5944). Such misconceptions have a great effect upon city residents' opinions on the needs and issues of the homeless, which in turn leads to stigmatization of the population.

Over half of all Americans believe that communities are safer when people do not live on streets, yet less than half agree that they desire to live in a community "that provides for the care of its homeless citizens." Only 19% believe that "homeless people could get back on their feet and become self-sufficient if only they could receive proper housing" (Gallup Inc.). A additional 15% believe that communities should enforce laws that would prevent homeless from gathering in public areas such as parks and libraries. Such thinking leads many municipalities to develop legislation that works to force homeless people out of the public's eye rather than provide for their needs, an approach that has effectively made being homeless illegal in many American cities.

Criminalization

Local reactions to homeless populations within urban areas have varied over time and often play out in different ways depending on the location. However, the aggregate number of laws forbidding activities that are usually attributable to homeless populations has risen dramatically in recent years. They range from minor inconveniences that are purposely designed into the cityscape (park benches with arm rests to prevent lying down) to the extreme (anti-loitering laws). In Seattle in particular, the city has moved away from a traditional form of welfare state that tolerated the presence of vagrants, to one in which decision makers and law enforcement actively work to banish the homeless from the public's eye (Beckett). An exploration of some examples provides a glimpse into how the urban poor have been marginalized in different ways.

Prohibition of Gathering/Loitering

Anti-loitering signs can be seen throughout many cities and towns in the United States. Often they exist near privately owned businesses or properties, but in some cases have worked their way in to public areas such as parks, places that one might expect people to loiter. Anti-loitering laws are some of the most oppressive and far-reaching forms of public space regulation, having a profound impact on homeless populations. As researcher Mark Malone contends, the decision makers' "rationale behind American vagrancy statutes - perpetuates the theory that society must have a means of removing the idle and undesirable from its midst before their potential for criminal activity is realized" (Malone 756). While such laws may sometimes be challenged as a violation of the first amendment's protection of the right to peaceful assembly, there still exists a significant amount of such legislation in many American cities.

One of the oft-cited anti-loitering laws that inspired many analogous forms of legislation is Chicago's Municipal Code 8-4-015. This law made it an offense for anyone to "remain in any one place with no apparent purpose" in the presence of a suspected gang member when ordered by a police officer to move on (Poulos). This law was eventually struck down in 2000 by the Supreme Court as being too vague to be protected by the constitution, and was amended to define loitering with more descriptive, yet arguably still ambiguous, language: "remaining in any one place under circumstances that would warrant a reasonable person to believe that the purpose or effect of that behavior is to enable a criminal street gang to establish control over identifiable areas, to intimidate others from entering those areas, or to conceal illegal activities" (Chicago § 8-4-015). Though this law was eventually overturned, it succeeded in forcing hundreds of homeless out of the city's public spaces during its application (Herz, 58).

In a survey of cities completed by the National Law Center on Homelessness and Poverty (NLCHP), it was revealed that:

- 33% of American cities have city-wide bans on loitering in public, a 35% increase in such laws since 2011.
- 65% of cities ban loitering in particular public places, a 3% decrease in such laws (NLCHP 8).

In Seattle, a criminal trespassing program exists that allows for business owners to admonish offenders with the aid of the police. While the program's current iteration is

debatably unfair to the homeless sleeping outside, the previous version that lasted until 2011 was unquestionably oppressive. It allowed the police to ban people indefinitely from certain areas after being stopped for loitering or suspected criminal activity, all without involving the courts. The ordinance is estimated to have banned hundreds of people without reason. “Defense attorneys and civil-rights activists say the policy unfairly (banned) vulnerable people, including the homeless, and criminalized their existence rather than just their behavior. Many people banned from businesses and public property often had no other place to go” (Williams).

Prohibition of Public Camping

The prohibition of public camping in public areas is one of the more obvious ways to keep the homeless from utilizing public areas such as parks or plazas at night. Many cities develop broad code amendments to cover any perceivable sleeping arrangement, making it nearly impossible for homeless individuals to escape prosecution. For example, the city of Minneapolis has made it illegal for a person to utilize a “camp car, house trailer, automobile, tent or other temporary structure” as short-term housing anywhere within the city (NLCHP 18).

The banning of public camping effectively makes much of the city off limits to the homeless, relegating them to the periphery or making them take precautions to hide their sleeping arrangements from law enforcement. Such oppression has recently caught the attention of the Department of Justice, which has declared it illegal to force the homeless out of their shelters if it threatens their survival: “When cities impose criminal penalties on homeless people for performing necessary, life-sustaining activities in public places when there are no sheltered alternatives, such actions may violate the cruel and unusual punishment clause of the Eighth Amendment” (NLCHP 18). Cities are able to sidestep any potential legal pitfalls, however, by providing some form of alternative shelter for homeless populations, regardless of whether the supply is sufficient enough to support the entire population.

According to the NLCHP:

- 34% of cities have city-wide bans on camping. This represents a 60% increase in such laws since 2011.
- 57% of cities ban camping in particular public places, a 16% increase (NLCHP 18).

Prohibition of Lying or Sitting

While it may seem unthinkable, some municipalities have made it illegal to sit or lie down in public areas. Often these rules are meant to keep public sidewalks clear, but have in some cases taken form as time limits for sitting in public plazas and parks. Spokane, Washington's infamous sit-lie law was passed in 2013 and has been used to force homeless people to move from encampment sites as demanded, especially in the downtown area. Breaking the law is a misdemeanor punishable by up to a \$5,000 fine or one year in jail. About 65 people, the majority of them homeless, have been cited since its enactment.

According to the NLCHP:

- 53% of American cities have laws prohibiting sitting or lying down in public, a 43% increase in such laws since 2011 (NLCHP 8).

The City of Seattle was the first major American city to enact a "sit/lie" regulation, which was passed in 1993. Following a 1996 decision by the 9th U.S. Circuit Court of Appeals that upheld the act, the city continues to enforce the law today (Knight). It specifically applies to the downtown business core and prohibits anyone from sitting or lying on the sidewalk between the hours of 7 a.m. and 9 p.m. Violators are given a \$50 citation, and in some cases taken to jail. Such enforcement does little more than displace homeless individuals during the daytime, forcing them to relocate elsewhere during the enforced time.

Prohibition of Feeding the Poor

In recent years the distribution of food to poor or homeless persons in public areas has come under fire, with legislation enacted in various American cities. One such law made national news in 2014 when a 90-year-old man by the name of Arnold Abbott was arrested in St. Petersburg, Florida for violating a food-sharing prohibition that was passed two days earlier (Holley). After much deliberation in court the ordinance was rescinded, but many other cities continue to enforce laws similar to the one in Fort Lauderdale. Since 2013 at least 31 cities have passed regulations that limit or prohibit the feeding of homeless individuals (NLCHP). These regulations usually come in one of two forms; the prohibition of the utilization of public spaces for food distribution, or the requirement that food preparers and handlers obtain a permit beforehand.

Prohibition of Living in Vehicles

Those who are lucky enough to have a vehicle in their name often utilize it for shelter before being forced to spend a night outdoors. However, many cities have passed legislation that works to limit people living in their cars by enforcing parking time limits, neighborhood parking permits, or outright bans on vehicle-sleeping. The increase of such regulations was the largest of any category that the National Law Center on Homelessness and Poverty examined. In 2014, 81 cities were found to have banned sleeping in vehicles outright, and increase of 119% since 2011 (NLCHP 24).

The city of Palo Alto enacted such a ban in 2013 in an attempt to curb the increase of people living in RVs and personal vehicles near a social service center. The resulting legislation made it illegal to use personal vehicles as dwellings, with offenders potentially facing a misdemeanor charge, six-months in jail, and/or a one thousand dollar fine (Green). Fortunately, a new city council ultimately reversed this legislation a year later. However, many cities around the country continue to pursue legislation similar to that of Palo Alto's ban. In Seattle, local law currently prohibits sleeping in a vehicle for a period greater than 72 hours.

Destruction of Homeless Property

Many American cities tend to confiscate and/or dispose of homeless individuals' belongings when clearing out an illegal campsite. These possessions are often removed with complete disregard of their contents, leading in some cases to mental and/or physical injury for those that are targeted. "The destruction of highly valuable or very difficult to replace items, such as birth certificates, social security cards, or photo identification, causes considerable harm to homeless people. Worse yet, the loss of medicine or medical equipment can become a matter of life and death" (NLCHP 23).

A case was recently brought forward against the city of Los Angeles citing the illegal seizure and destruction of homeless individuals' property. Some alleged that their property was not returned to them upon leaving jail or rehab, and in other cases had been destroyed during police clearance efforts. According to civil rights lawyer Carol Sobel, "The (city is) using justifications to take the property and destroy it in the name of cleaning up the city. What that does is makes homeless people criminals and leaves them without any lifeline" (Huang). In another lawsuit brought against the city of Fresno, it was found that dozens of people had had their possessions destroyed during police raids over a number of years. Many of these items included medicine,

identification papers, and sentimental possessions. Ultimately the city of Fresno was found to have overreached its power in the court case *Kincaid vs. City of Fresno*, and settled for \$1.485 million in damages.

Marginalization

If the homeless aren't forced out of a city through direct legislation, their day-to-day activities may be made more difficult through a number of less discernable actions, such as design interventions that make lying down or loitering nearly impossible to do. Some of these approaches are subtle and meant to make simple tasks more difficult, while others are overt and act as a warning to potential offenders.

In William Whyte's book *The Social Life of Small Urban Spaces*, the author discusses how numerous public spaces have been designed to actively force the destitute out. As a result, the entire public realm is made worse off. "The biggest single obstacle to the provision of better public space is the undesirables problem. They are themselves not too much of a problem. It is the actions taken to combat them that is the problem" (Whyte 156). Such actions, known as defensive architecture, include making lying down incredibly difficult in public areas (Fig. 1.2). Park benches are constructed with armrests every few feet, prohibiting one's ability to lounge prostrate (Fig. 1.3). Barriers are put at a height that is too difficult for people to easily access, and plazas are left devoid of anywhere to stretch out but on the ground. The aggregate effect of these efforts is that many public areas become so untenable that they remain completely underutilized, becoming wasted areas of space in the city. Whyte goes on to say that the only true way to deal with "undesirables" is to in fact accommodate them, and make a space so inviting that their presence is unnoticed in the crowd. "The best way to handle the problem of undesirables is to make a place attractive to everyone else... The way people use a place mirrors expectations" (Whyte 158).

Ocean Howell of the University of Oregon discusses defensive architecture's ability to effectively, yet imperceptibly, target its victims; "When you're designed against, you know it. Other people might not see it, but you will. The message is clear: you are not a member of the public, at least not of the public that is welcome here" (Andreou). By introducing subtle design interventions into areas where the homeless may gather, these groups are made extremely uncomfortable and forced to find refuge elsewhere. Such efforts hide the homeless rather than help them, making their already challenging existence more difficult as they become less welcome in the areas that the rest of the public gathers or moves through.

Lasting Effect

The aggregate effect of the aforementioned reactions to homelessness is the continued disenfranchisement of the homeless themselves. Such psychological and regulatory marginalization forces this population to become ever more resourceful with their few remaining options, fabricating shelter in areas where they will likely be ignored or hidden away from the public. In many cases they take up residence in the underutilized areas that have been formed through the city building process. According to the 2015 One Night Count, there were 1,366 homeless utilizing Seattle’s parking garages, benches, vacant structures, roadways, doorways and alleys as a home for the night (Figure 2). It is within the liminal spaces created by the city’s massive road infrastructure that I look to provide the homeless with an improved form of shelter, working to reverse years of oppression.

Summary of the 2016 Unsheltered Homeless Count in Selected Areas of King County

	SEATTLE	KENT	NORTH END	EAST SIDE	SW KING CO.	FEDERAL WAY	RENTON	NIGHT OWL BUSES	AUBURN	VASHON ISLAND	TOTAL
Men	827	21	55	55	65	25	46	109	13	9	1,225
Women	153	7	12	34	21	7	14	19	3	1	271
Gender Unknown	1,951	136	64	150	226	231	100	0	94	28	2,980
Minor (under 18)	11	1	4	6	3	0	0	4	0	0	29
TOTAL	2,942	165	135	245	315	263	160	132	110	38	4,505
Benches	46	2	2	1	5	1	0	0	0	0	57
Parking Garages	26	2	0	25	0	0	1	0	0	0	54
Cars/Trucks	914	42	53	85	161	199	75	0	48	31	1,608
Structures	533	4	4	27	55	2	18	0	3	7	653
Under Roadways	257	2	2	8	4	1	14	0	2	0	290
Doorways	271	1	2	3	10	3	7	0	0	0	297
City Parks	24	0	3	0	0	0	9	0	30	0	66
Bushes/ Undergrowth	37	60	3	9	2	30	12	0	0	0	153
Bus Stops	29	21	5	0	0	8	1	0	0	0	64
Alleys	32	9	0	0	0	0	0	0	0	0	41
Walking Around	494	14	10	15	13	13	16	0	4	0	579
Other	279	8	51	72	65	6	7	132	23	0	643
TOTAL	2,942	165	135	245	315	263	160	132	110	38	4,505

Table 2. Source: King County One Night Count

Chapter 2

Homeless Encampments



Figure 2.1: Othello Tiny Homes: Source: Max Baker

Encampment Qualities

The passing of ordinance 124747 marked Seattle's first official acknowledgement of sanctioned encampments' role in combating homelessness. While there had previously existed a small number of camps on land controlled by religious institutions, they were never considered as a serious tool for addressing issues surrounding homelessness. Their presence has historically been tolerated at best, and severely condemned at worst. The passing of ordinance 124747 changes this rationale dramatically by working to create a greater number of sanctioned encampments within the city of Seattle. It works to legitimize the benefits of legal encampments, of which there are arguably several.

Safety and Security

Issues of safety facing homeless are both serious and innumerable. Exposure to the elements, criminal and sexual assault, and illness are just a few of the problems that affect the homeless every day. In 2015, 67 homeless died on the streets of King County alone (Feit). These deaths were attributed to a variety of causes, but a handful drew the public's eye due to their violent nature. One incident involved a married homeless couple living beneath the Magnolia Bridge in the Seattle neighborhood of Interbay. During the evening of August 24th, 2015, the couple was brutally attacked by an individual while they were sleeping in their tent, resulting in severe injuries for the husband and the death of the wife. The assailant, a homeless man who was purportedly known to have "substance abuse issues, a history of assaultive behavior and a criminal history," was apprehended by the Seattle Police Department's SWAT team shortly thereafter (Q13). A second assault that drew national attention occurred beneath the Interstate 5 viaduct in an area known as "the Jungle," a controversial area that will be described in greater detail later. Three teens ranging in age from 13 to 17 shot five homeless individuals during the early morning of January 26th, 2016, resulting in the deaths of two (Moyer). These cases reflect just how dangerous life on the streets can be for the homeless and how valuable an extra layer of security provided by formal housing can be.

Exposure to the elements is of utmost concern to the homeless as well. In the United States it is estimated that over seven hundred people experiencing or at risk of homelessness are killed from hypothermia each year. Unfortunately, many winter

shelters across the country have temperature ranges that regulate whether or not they will be open. These cutoffs can range from 40 degrees Fahrenheit (Berkeley, CA) down to 13 degrees (Baltimore, MD), though hypothermia may set in at temperatures as high as 50 degrees ("Dangers of Cold"). Allowing for these shelters to be open 24 hours during the winter months would be a significant improvement over the current system. According to the National Coalition for the Homeless, "There is general consensus among public health officials, medical professionals and service providers that to reduce the incidence of hypothermia nationwide, local communities should implement effective and timely strategies to address the needs of vulnerable populations, including creating temporary homeless shelters and extending the hours of operation for existing shelters" ("Dangers of Cold").

Homeless encampments help to ensure individuals' safety by providing them with a more robust support network and a formal security network. The City of Seattle requires that a homeless encampment's supporting organization establish a security system within the camp. For example, the non-profit homeless organization Nickelsville, which is responsible for the operation of two of Seattle's encampments, runs an incredibly effective security team, ensuring that at least two security guards (each of whom are residents) are on duty at any time. These individuals are "responsible for answering the phone, greeting and logging in visitors and donations, arranging for escorts for all visitors, investigating and noting any incidents that occur on their shift, coordinating with the Camp Masters to house both new permanent residents and overnight transient guests, coordinating with Camp Coordinators to manage resources and donations, carrying out regular internal and perimeter patrols, ensuring that residents with doctor's appointments or jobs are awake and out of camp on time to keep those appointments, interceding in personal conflicts, and simply being the one ear that is always available for residents' concerns" (Brayden). The sense of refuge that such a security apparatus provides is significant for residents, allowing them to worry less about their personal safety while in the camp and the wellbeing of their personal belongings when they are gone. The city of Seattle also requires background checks for all residents in order to prevent sex offenders from residing within the encampments, a necessary step due to the possibility of families and children residing within the camps. Strict rules are often applied by the host organization to ensure that residents are provided with a safe, clean and substance-free refuge. Violators of an encampment's code of conduct face temporary bans up to 72 hours, and for more offensive incidents may be banned indefinitely (Brayden).

Cost Effectiveness

Homeless encampments are relatively cost-effective forms of temporary shelter. A single encampment is estimated to cost \$5,000 per month to construct and operate on average, equating to roughly \$50 per resident in a fully occupied encampment (“Tent City Primer”). This covers operations and site needs such as portable restrooms, a refuse dumpster and waste removal, two daily bus tickets per person, and other various necessities. In situations where tiny homes are erected within encampments, initial costs increase slightly. Seattle’s Low Income Housing Institute (LIHI) estimates that it costs \$2,200 to construct one of their tiny homes (labor is completed by residents or volunteers at no cost) (“Tiny Houses”). In the case of the Ballard encampment, the five tiny house structures were constructed by Sallal Grange, the Tulalip Tribes TERO Training Program and YouthBuild. LIHI, Seattle Jaycees, Sustainable Ballard, Home Depot, and the Lucky 7 Foundation worked together to pay for the materials. These tiny homes are entirely funded through private donations, reducing costs to taxpayers in providing the homeless with shelter. The cost of relocating a 100-person encampment to a new site was estimated by Greater Seattle Cares to be roughly \$2,500 in 2010, which includes the cost of truck rentals, relocation of portable toilets, trash service and any repairs to tents and platforms (GSC – FR 2010).

In comparison, traditional homeless shelters can cost significantly more than formal encampments. A 2006 study by the University of Pennsylvania of 300 homeless residential programs across 14 cities found an average per bed-night cost of \$14.05 for emergency shelter programs, greater than both transitional housing programs (\$13.10) and permanent supportive housing (\$11.38). These emergency shelter programs also require a greater number of employees and volunteers to operate, with an average bed-staff ratio of 5.84 in comparison to 8.41 and 6.08 for transitional housing and permanent supportive housing, respectively (Wong 81). In the city of Seattle, it is estimated that \$9,009,662 is spent on a total of 1,533 emergency overnight shelter beds each year (Human Services Department 21). This equates to roughly \$5,877 per bed each year, nearly ten times the \$600 annual operating cost estimated for each encampment resident. Transitional housing programs, which provide housing to individuals on a 12-18 month basis while they develop a housing and employment stability plan, cost even more. The City allocates \$7,334,693 to 22 local agencies that in turn provide 647 such beds, equating to \$11,337 per bed annually, over five times the cost of a LIHI tiny home (HSD 23). This makes homeless encampment shelters the most inexpensive form of homeless shelter currently available in city of Seattle by far.

While the costs of any homelessness housing program may seem significant, it should be noted that the cost of leaving people on the street is always greater. A 2009 study by the city of Los Angeles found that homeless individuals can cost the taxpayers between \$406 and \$5,038 a month dependent on their needs (Fleming 53). When housing is provided, costs are estimated to decrease by the following amounts: 79 percent for disabled, chronically homeless individuals that move into supportive housing; 50 percent for the entire population of homeless General Relief recipients when individuals move temporarily or permanently out of homelessness; 19 percent for individuals with jail histories and substance abuse problems who receive short-term General Relief emergency housing vouchers for four or more months (Fleming 53). It was also found that public costs increase as an individual grows older, making it essential to intervene early. Similar findings were generated in Colorado after the state chose to provide semi-permanent housing for 200 homeless individuals in a former correctional facility in Fort Lyons, CO. It was discovered that such a program would cost just \$16,813 per person in comparison to the estimated \$43,240 in public funds that the Colorado Coalition for the Homeless estimates are spent on homeless individuals each year (One Step Away). Such results make the argument in support of inexpensive, effectual homeless encampment programs quite strong, effectively legitimizing their role to taxpayers.

Serve Resident Needs

In the National Law Center on Homelessness and Poverty's (NLCHP) publication *Welcome Home: The Rise of Tent Cities in the United States*, the authors explore the reasons behind why some individuals may choose to live in homeless encampments instead of emergency shelters. In researching two sizable encampments in Providence, Rhode Island known as Hope City and Camp Runamuck, they came up with four main motives: persistent problems with the shelter system; lack of availability of adequate alternatives; lack of responsiveness to the needs and preferences of homeless individuals; and a lack of coordination among service providers (Hunter 19). They cited that many shelters in the city only provide overnight accommodations and force them pack up their belongings each day. Those individuals who work night shifts are severely disadvantaged by not having a place to return to following work. Couples are often forced to sleep separately in male or female-only quarters as well. Such a system is inefficient and robs the homeless of time and energy, making it more difficult to find employment and complete errands.

Another case study by the NLCHP of an encampment known as Tent City in Lakewood,

New Jersey identified explanations similar to those identified in Providence. The main reasons were “first, a shelter system that is completely inadequate and, in many communities, nearly nonexistent; second, restrictive state eligibility criteria that leave many households ineligible for emergency public assistance they desperately need; and third, a long-term failure to provide enough housing affordable to the most disadvantaged members of the community” (Hunter 30). While there are alternative shelter programs available to the homeless in which rooms in extended stay motels are provided for a year or more, applicants must meet the eligibility requirements for General Assistance, Temporary Assistance for Needy Families (TANF), or Supplemental Security Income (SSI). If these categorical requirements are not met, few options remain for homeless in the area, leading them to seek accommodations in Tent City.

In Virginia Werner’s 2014 thesis *Planning for Self-Organized Homeless Camps: Policy, Community Relations, and Locational Process*, the author interviewed residents of the Kirkland, Washington encampment known as Camp Unity Eastside, a 65 resident tent city six miles east of Seattle. She identifies four main factors that played into residents’ connection with Camp Unity: personal-empowerment, an identification of the camp as their home, a personal loyalty to the success of the camp, and the safety of personal belongings and one’s self within the camp. The group’s democratic organization provides each resident with a say in the daily operation and direction of the encampment, an experience that many homeless don’t have on the street. One host organizer was quoted as saying “I think (Camp Unity Eastside members’) greatest strength is that they are doing something proactive on their own behalf and that is really just amazing. They said [about Tent City 4] ‘this program isn’t good enough, it’s not getting us where we need to be so we’re going to take those ideas and make our own and go in the way we want to do it.’ That is just huge” (Werner 101). This personal connection to the success of the encampment plays a significant role in empowering residents to become actively involved and work toward the improvement of their neighbors’ lives.

While many residents prefer the freedom and conveniences that an encampment affords, some professionals believe these forms of shelter are inappropriate for properly serving the needs of a city’s homeless population. This belief was recently reinforced in Seattle when Barbara Poppe, the former Executive Director of the United States Interagency Council on Homelessness, came to the city at the request of Mayor Ed Murray to provide consultation on issues surrounding the homelessness crisis. After a three-day visit to the region, she came to the conclusion that encampments were not an effective tactic. In an interview with the *Seattle Times*, she was quoted as saying,

“It’s just unconscionable to me that (homeless encampment legislation) is a choice that’s been made here. That said, I understand there’s great pressure to have a short-term solution. But I don’t happen to think these encampments are the best solution” (Beekman, “Stop Opening Tent Cities”). Her rationale was that formal housing should be the end goal for the city’s homeless, and that by legitimizing encampments the City is wasting resources and thus not fully pursuing more effective solutions. Critics of her conclusions highlight that Ms. Poppe never actually visited an encampment in person to assess conditions, and that the \$80,000 of taxpayer funds that was paid towards her consultation could have been directly spent on homelessness efforts instead. They also defend the idea that residents often enjoy the organizational structure and freedom provided by encampments in comparison to other shelter options that are currently provided within Seattle.

Adaptability

The temporary nature of sanctioned homeless encampments allows them to relocate and adapt to an evolving urban landscape more easily than permanent shelters. The Puget Sound’s employment and cultural centers evolve and move over time like any other region’s, and homeowners and renters are often able to relocate if necessary to be closer to work, school, etc. Many of Seattle’s homeless shelters, however, have been in their current location for years or even decades, invariably linked to their original site. For instance, the Seattle Union Gospel Mission has been operating in Pioneer Square since the great depression over 80 years ago (“About Us”). Since that time, Pioneer Square has evolved from a waterfront commercial hub to a depressed skid row to the focal-point of urban renewal efforts of the 1970s. Now the neighborhood is experiencing rapid gentrification, with many businesses and affluent residents moving into the area. While the efforts and steadfastness of the Union Gospel Mission are admirable and should continue, it is perhaps more debatable whether or not the organization has always been in the right location to serve its users. As purely a matter of speculation, had the Mission been able to relocate over time, perhaps they would have saved their clients time and effort in utilizing their services.

Homeless encampments’ requirements for impermanence force them to be flexible and adapt to changing needs. The city of Seattle’s Land Use Code Section 23.42.056 authorizes a transitional encampment interim use permit for up to one year. Such a permit is a Type I process, which “does not provide for formal public notice or appeal opportunities and is renewable one time for an additional year, subject to certain criteria”. After two years at one site, an encampment must relocate to a different site

within the city and apply for a new permit. The same site may be used again after 12 months of vacancy. Between 2004 and 2007 alone, Seattle Housing and Resource Effort's Tent City 4 moved between sixteen different locations on the east side of Lake Washington, at times returning to previous sites ("Tent City 4"). In some cases, this was due to neighborhood resistance, but in others it was because a faith-based organization chose to reach out and act as a host. Such flexibility allows encampments to relocate as needed while jurisdictions work to develop legislation and/or identify long-term solutions.

Challenges

A number of challenges face homeless encampment siting and operation. One of the main limitations is Seattle's requirement that a third-party organization oversee day-to-day operations at each site. Only two non-profits meet the stringent requirements currently set forth: Nickelsville and SHARE/WHEEL. This limitation makes it difficult for newer and/or smaller entities to apply for a temporary use permit from the city. It also leaves encampments vulnerable to suffering any organizational or financial issues that the controlling organization may experience. For example, SHARE/WHEEL experienced a funding crisis in March 2016 that forced it to temporarily close 15 indoor shelters (Groover). While the three outdoor encampments the group operates were not directly affected, the closures did leave some residents and community members unsure of the group's future stability.

Another issue facing the siting of encampments is the potential backlash from neighboring residents. When the city announced its final encampment site selections in 2015, a significant outcry developed concerning the Ballard and Interbay locations. The Ballard Chamber of Commerce, the Central Ballard Residents Association, the Ballard Partnership for Smart Growth, and the North Seattle Industrial Association drafted a letter to the mayor protesting the selection of a site on Market St., stating that a more involved public process should have been undertaken (Broom). The Interbay Neighborhood Association also drafted a response regarding the Interbay site, saying that it was an inappropriate location to site a homeless encampment due to soil contamination. It was later found that the contaminated soil had already been properly remediated and posed no significant threat to encampment residents (Broom). These efforts together reflect a general disdain for sanctioned encampments in residential neighborhoods, exposing community NIMBYism that could possibly prevent a camp's construction. However, in the case of Tent City 4, a homeless encampment in Kirkland, WA, it was found that the community's initial negative response to the encampment

eventually gave way to acceptance, resulting in an amendment to the city's code making it easier to establish new sites (Werner 122). Such a finding highlights the positive and potentially transformative effect a homeless encampment can have on the surrounding community.

Chapter 3

Liminal Spaces



Figure 3.1: Ship Canal Bridge: Source: Max Baker

Urban Liminal Spaces

Bridges and overpasses are undeniably vital elements of the urban landscape. They are able to accommodate and/or overcome challenges in geography or urban form, linking people, goods and services throughout the city. In the modern city they may come to represent the community itself, acting as grand entrances into the municipality. Yet these structures can also work to fragment neighborhoods, simultaneously creating voids in the urban landscape that are difficult to improve. Planners and designers have sometimes attempted to utilize these covered "liminal" spaces, but usually end up disregarding them completely.

The love affair with bridges in the collective American psyche is easy to observe. The Golden Gate Bridge, perhaps the most photographed bridge in the world, is denoted as one of the seven Wonders of the Modern World by the American Society of Engineers (Dept. of Civil Engineering). John Roebling, the engineer behind the Brooklyn Bridge, opined, "The contemplated (Brooklyn Bridge), when constructed in accordance with my design, will not only be the greatest Bridge in existence, but it will be the greatest engineering work of this continent, and of the age. Its most conspicuous features, the great towers, will serve as landmarks to the adjoining cities, and they will be ranked as national monuments" (Trachtenberg 79). Not only monuments to the achievements of modern technology, bridges have been vital components to the modernization and evolution of the United States. When shipping companies grew frustrated with the inefficiency of ferry crossing, designers worked to develop innovative structures that were able to span the wide rivers of the Midwest, resulting in the more efficient movement of freight and labor (Cleary 12).

The development of the automobile in the 20th century only amplified the importance of bridges. The development of transcontinental trunk routes, increased speed limits, and the expansion of vehicular shipments made seamless connections between cities more necessary. The role of bridges came to expand, being seen more as "components of systems rather than as isolated objects" (Cleary 14). Thanks to this evolution, bridges have now become indispensable cogs of American civilization. As of 2015, there existed 611,840 bridges within the Federal Highway Administration's National Bridge Inventory (FHWA). This equates to about one bridge for every 520 people in the United States.

While it is difficult to argue that bridges have been valuable in expediting travel and creating wealth within the country, their installation in urban landscapes has not always been welcome. While often thought to connect separated people and places, elevated structures may be part of a larger system that works to fragment the city. For example, the Triborough Bridge complex in New York City effectively works to connect the boroughs of Manhattan, Queens and Brooklyn. While a helpful link for motorists, its role as a part of the Brooklyn-Queens Expressway makes its relationship with surrounding neighborhoods more divisive (Fig. 3.2). This roadway system was a brainchild of “powerbroker” Robert Moses, the then chair of the Triborough Bridge Authority. Rather than run along the waterfront or underground, he had the freeway system forced through the heart of both Brooklyn and Queens, fragmenting once vibrant residential areas. Adjacent neighborhoods have since had to deal with increased air pollution, traffic noise and inconvenient highway crossings. Current Cobble Hill Association President Roy Sloane has described its negative impact upon his section of the city as, “A scar. It’s a wound that was inflicted upon us, and we’re trying to do our best to heal that wound” (Rutkowski).



Figure 3.2: Brooklyn-Queens Expressway: Source: MusikAnimal, Wikimedia Commons

Structures such as viaducts or elevated roadways have also engendered fierce protests from city residents. The double decker Embarcadero Freeway in San Francisco, which ran along the city’s eastern edge from 1959 to 1991, effectively disconnected downtown from the city historic waterfront (Fig 3.3). The 1960s plan to extend this structure west to the Golden Gate Bridge drew extreme criticism from residents, prompting one of the city’s largest recorded protest rallies with over 200,000 attendees (Ross). The vitriol was so powerful that the San Francisco Board of Supervisors was eventually forced to pass a resolution opposing the construction of most of the planned freeways in the city. In reflecting on the failed project, San Francisco Chronicle architecture critic John King stated, “[The Embarcadero Freeway] cut off the downtown

from the water that gave birth to it, and it left the iconic Ferry Building, a statuesque survivor of the 1906 earthquake, stranded behind a dark wall of car exhaust and noise. Oppressive does not begin to describe it..." (King).

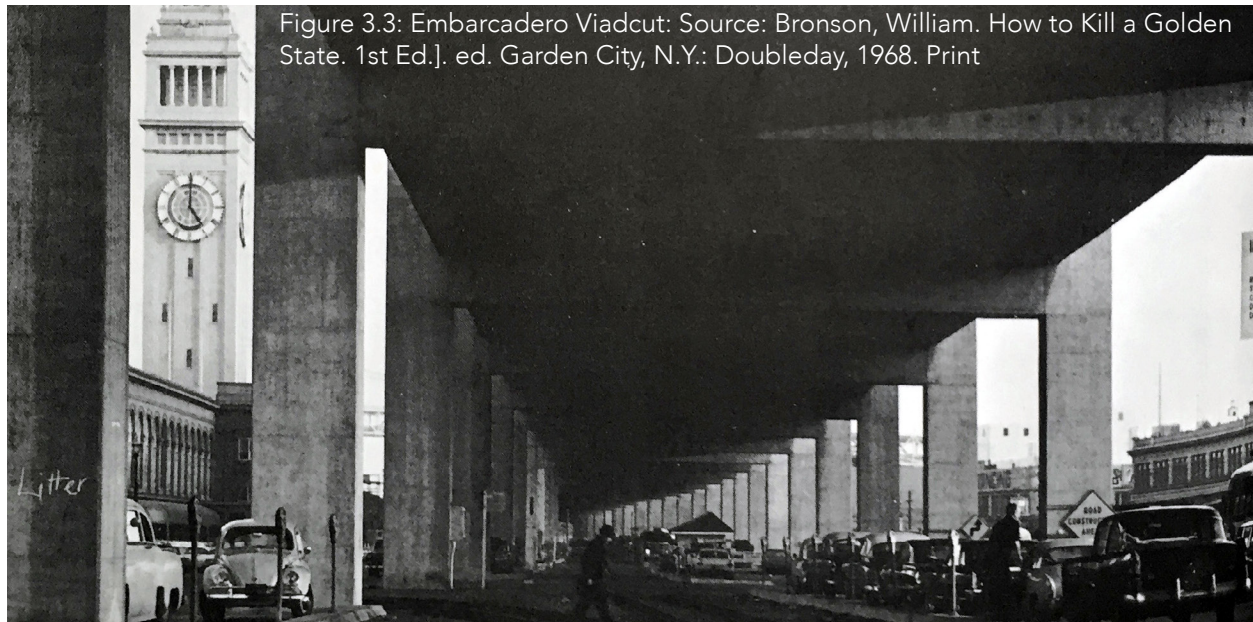

Figure 3.3: Embarcadero Viadcut: Source: Bronson, William. How to Kill a Golden State. 1st Ed.]. ed. Garden City, N.Y.: Doubleday, 1968. Print

Seattle's own Alaskan viaduct has received unforgiving criticism as well. Completed in 1953, the three-story structure runs for about a mile along the city's historic waterfront, providing motorists with convenient access to downtown while shadowing those at street level (Fig 3.4). Little time passed after its completion before local residents began to call for its demolition. In the early 1980s the Sierra Club Urban Committee pushed for removal, stating, "the value of the waterfront area for commercial and residential uses, and for tourism, will far exceed the value of the viaduct" (Bodenmuller). Even Ray Finke, Seattle's city engineer during the construction of the viaduct, was quoted as saying "It is not beautiful" (WSDOT). Ultimately these critics will be vindicated as the Washington State Department of Transportation plans for its removal following the completion of the new State Route 99 tunnel.



Figure 3.4: Alaskan Way Viadcut: Source: Google

While these examples demonstrate projects that have been or are being amended on a large scale, there are many more small-scale structures within the urban realm that cannot be so easily removed or replaced. Offramps/onramps, pedestrian overpasses, water crossings and elevated rail lines are just a few of the urban elements that exist within the urban realm. These structures often create voids in the landscape, which Philipp Rode of the London School of Economics and Political Space coins as “negative spaces”. He describes these spaces as ones that are not planned, but rather left over in the city building process (Erlacher). Their function was not conceived in the design process, and it is only after they have been created that they’re presence is addressed. Rode posits that they are often created by a system of political and economic disturbance that has redefined the meaning of urban spaces from the collective to the private.

Bridges are interesting producers of liminal space, for while they have the ability to join separated areas, they can also work to fragment coherent regions. “The continuum of the space that stretches out longitudinally below is interrupted by the fact of its being crossed and the structures and supports the bridge requires (Erlacher 11).” Utilization of this liminal space is often difficult, limiting the possibility for intervention. In some cases, low impact projects are proposed, such as art installations or public parks. More often than not they are left vacant or are utilized for storage by the bridge’s operators.



Figure 3.5: Green Lake Boulevard: Source: Max Baker

In Gil Doron’s essay “The Dead Zone and the Architecture of Transgression” the author describes these spaces as “Transgressive Zones.” These zones are “where architecture and planning reaches the limit of the plan and the intention of the architect. This is the place and time where a suspension appears, suspending the architect from his architecture, from his assumed sovereignty over architecture” (Doron 258). In the

public's mind they are often described as being dead zones, where formal activities are unable to occur due to constraints placed upon them by their history, location or access. Only through grand interventions do people think that such areas can be improved. "(Architects and planners) try to regain their subjectivity by strategies of depicting them as Void and Waste(of)land, etc., and later on use cleansing strategies like redevelopment, revitalization and Renaissanciation" (252). Dolon sees these places as forever existing outside of the modern teachings of architecture, where the rigid application of enhancements stemming from an ordered school of thought will likely fail. Instead, he advocates for a new approach that embraces these areas of transgression and works to utilize them in a constructive manner, rather than aim to do away with them entirely.



Figure 3.6: Green Lake Park and Ride: Source: Max Baker

While it is seemingly difficult to approach these sites from a design perspective, they offer great opportunity for new and creative interventions. In the ever-changing urban landscape where no vacant parcel is safe from development, these spaces exist in another plain entirely, less exposed to the ebbs and flows of the market and government action. They are spaces ripe for engagement, for their improvement can lead to better connected, vibrant neighborhoods. By working to engage these spaces rather than ignore them, the fragmentation caused by elevated roadways may be remediated to some degree.



Figure 3.7: Aurora Bridge. Source: Max Baker

Liminal Space Precedents

Urban areas are working to accommodate a disproportionate share of the world's ever-increasing population as evolving economies and trade patterns work to make rural areas less viable. In 2007 the U.N. estimated that over half of the world's people lived in urban areas for the first time in human history (UN Fund). This equates to roughly 3.5 billion people living within cities. The proportion of urban dwellers is expected to increase to roughly two thirds by 2030 ("Populations on the Rise"). However, such an unprecedented number of urbanites are expected to live on less than three percent of the Earth's total land surface area, making it clear that density is on the rise in these developed realms (Liu).

As more and more people continue to locate within a finite selection of land, the value of exploitable space increases dramatically. In Beijing, China's capital and second largest city, the value of all land within the city limits is estimated to stand at \$21.8 trillion, or five trillion dollars greater than the United States' Gross Domestic Product in 2012 (Chun). It goes without saying that as the population continues to grow in the world's major metropolitan centers, every available inch of urban land will need to play a role in accommodating its citizens.

Cities across the world contain a vast collection of covered liminal spaces, engaging them in various ways. In much of the developed world these areas are improved through a public process that leads to their eventual use as a civic space. In the urban centers of developing countries, these areas are frequently utilized in unsanctioned ways, often emerging to become dynamic centers of community for the disenfranchised. Innovative proposals that look to reclaim such areas are also being generated as urban designers look for new ways to exploit limited urban land. In exploring precedent cases, reimagined liminal spaces have been placed into one of three categories: the informal, the formal, and the prototypical. By examining how different cities and countries are attempting to utilize their covered urban spaces, lessons learned away and applied to the city of Seattle and its future homeless encampments.

Informal Uses

Jakarta's Living Bridge



Jakarta, Indonesia's capitol city, is currently home to ten million people and is the fastest growing urban area of Southeast Asia (World Bank). Indonesia itself has the second largest urban population in East Asia following China, with just 100 million people living in urban areas. Many of these residents have relocated to cities in recent years looking for work, but in many cases become homeless as new wealth remains largely concentrated with those in the upper class. Nearly five hundred thousand Jakartans were estimated to be in poverty in 2015, an eleven percent increase from the year before (Wardhani).

As these marginalized Jakartans look to survive within the urban landscape, they have developed some creative approaches to securing shelter. One such example is the Kuningan Bridge connecting the wealthy neighborhood of Menteng to downtown, a simple span that has evolved into a makeshift settlement for nearly 100 municipal workers. Located within the girders on the underside of the bridge, haphazard structures have been installed to create divisible shelters and amenities for residents. "The 'tenants' have built the wooden floor. They have also equipped this 'living room' with a television, a sound system, a few fans and outlets for lamps and mobile phones. They explain that they bribe an electricity employee for access to more than the 450



Figure 3.9: Jakarta Living Bridge. Source: Sanja Jovanovich / Global Post

watts of power wired in by their employers” (Dhumieres). Some residents have called this location home for over thirty years, coming to depend upon it for their livelihood.

What is unique about this situation is that is not so much an illegal squat as it is a city-sanctioned prohibited use. Most of the workers are employed by a subcontractor for the government, which works to house them within the space. “When asked about it, the municipality argued it wasn’t directly responsible for these workers, and wouldn’t discuss its subcontractor’s curious housing choice, nor these city workers’ questionable living conditions” (Dhumieres). While the space may not sound ideal to those accustomed to more formal housing arrangements, it is a marked improvement to living on city streets. This refuge is significantly cleaner, safer and more comfortable than many of the alternatives available to poor Jakartans. “While they admit their living standards are not ideal, they say they are grateful to their employers for providing them with a free place to live. ‘This is enough for us, it’s better than having to pay rent,’ says Fudoli, a 43-year-old gardener” (Dhumieres).

Informal Uses

New Delhi's School Under the Bridge

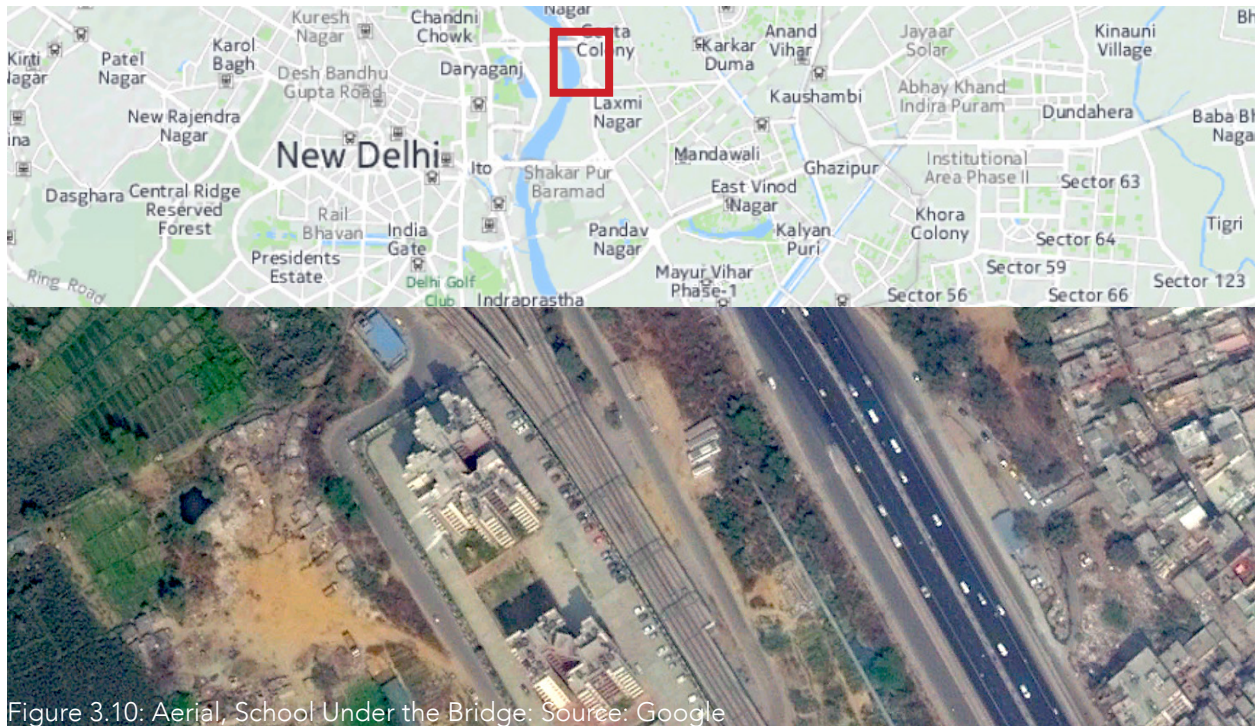

Figure 3.10: Aerial, School Under the Bridge. Source: Google

New Delhi's Metrorail system is one of the world's largest, carrying nearly a billion passengers each year. Much of the system's 100+ of infrastructure miles is elevated throughout the city, creating significant flyovers within neighborhoods. Many of the liminal spaces created underneath are used for rights of way or storage, but beneath one of these flyovers in the Shakarpur district of east Delhi, a local storeowner has fashioned a free school for impoverished children.

The "Free School: Under the Bridge" was developed by Rajesh Kumar Sharma in 2000 to supplement local childrens' school teachings (Saha). The program addresses a very serious issue facing India's children: lack of access to formal education. According to UNICEF, just under half of India's secondary-school aged boys and the majority of its girls don't attend school (A World at School). Acute poverty forces many children into work at a young age, causing them to forgo their schooling. Sharma attempts to address this problem by locating his school adjacent to a Metro station, in turn making it easier for his students to gain access. He also talks directly with local families, working to convince them that education will increase the likelihood of their children escaping the cycle of poverty.



Figure 3.11: School Under the Bridge: Source: Altaf Qadri / AP

The Free School teaches basic Hindi, English and mathematics to students between 9 am and 12 pm on weekdays, after which students are encouraged to attend a local government-run school. Sharma utilizes the backside of a wall for the Metrorail station above as a blackboard, and asks for donations for school supplies from local businesses and resident. Since its founding, the school has quadrupled in size from 50 to 200+ students. "In the Free School, we are assisted in completing our homework and understand what we were taught at school. Also, the time I spend here would have been otherwise wasted in roaming around or gossiping. The school is of great help," says (student) Pintu Kumar" (Saha).

Formal Uses

Mexico City's Bajo Puentes Program



With over 21 million residents, Mexico City is the most populous metropolitan area in the Western Hemisphere. Since the 1950s most of the population growth has occurred in the city's suburbs, with 17 million people or ninety percent of the city's total residents living in such neighborhoods today (Cox). Typical post-World War II development patterns transpired during this time, creating sprawling, albeit dense, neighborhoods that are heavily reliant on automobiles to get around. Highway overpasses dominate the landscape while the areas adjacent to them suffer.

Realizing that these covered spaces were often a nuisance for nearby residents due to their being used for trash dumping and illicit activity, the city's Department of Housing and Urban Development developed a pilot program in the late 2000s called Bajo Puentes, or Under Bridges. "Through the program, city officials persuade business owners and developers to move into an underutilized covered area by offering below-market lease rates. In return, the private sector foots the bill in the costs of cleanup, construction, and maintenance. To keep the focus on public space, the program stipulates that only one third of the area can be zoned for commercial uses, whereas half must remain public space and the remaining 20% allocated for parking. As of 2013, four spaces with a total area of 24,000 square meters have been successfully



Figure 3.13: Bajo Puentes space: Source: Dominic Bracco II / Prime

rehabilitated, and there are plans to develop at least twenty more areas” (Wang). Restaurants, cafés and even a gym have sprung up in these spaces, offering services for both commuters and tourists. The city-prescribed improvements to the space also provide affordable infrastructure for small businesses in the form of communal bathrooms, running water, electricity and lighting. Entrepreneurs have come to see the program as a unique opportunity for creating new commercial space, while local residents enjoy the benefits that the design interventions provide through the reutilization of these spaces. “These are places that improve public safety,” says Eduardo Aguilar, an Urban Planner for Mexico. “They have pedestrian crosswalks, they are well-lighted at night, and, most importantly, they attract a lot of people — which, in turn, brings more security” (Miroff).

Prototypical Uses

Under Bridge Action, Hong Kong



Figure 3.14 Aerial, Kwun Tong Bridge Site. Source: Google

Hong Kong is one of the most densely populated urban areas in the world, with over 17,000 people per square mile (ISD). It is incredibly limited by its geography, with the South China Sea coast to the south and steep hillsides to the north limiting development to a small strip of land alongside the city's harbor. It goes without saying that such concentrated development makes every inch of land within the city valuable, spurring creative approaches to accommodate ever-continuing growth within the municipality's borders.

Due to the city's tight housing market and increasing wealth disparity, more of Hong Kong's residents have been forced to sleep on the streets in recent years. A 2015 homeless one-night count revealed 1,614 people sleeping without formal shelter, a 14% increase over the previous year (Law). Of these, 256 were found to be sleeping in 24-hour grocery stores, a 400% increase from 2013. Most residents identified unaffordable or unattainable housing as being the root cause of their homelessness, regardless of whether they were gainfully employed or not. In some parts of the city, the average rent has climbed from HK\$1,550 to over HK\$4,000 in just a few years ("Hong Kong's 'New Homeless' Epidemic"). While emergency overnight shelters exist across the city, many of the recently homeless choose not to use them in an attempt to

save face with friends and family. This makes the need for more affordable, transitional housing all the more essential.

The group Under Bridge Action advocates for the use of the city's vast inventory of covered spaces as areas to locate residential structures. Over 1,900 bridges throughout Hong Kong were identified by the group that could potentially be exploited, not including pedestrian overpasses (Ko). They estimate that just one of the larger flyovers, Kwun Tong bridge, could accommodate anywhere between 300 and 500 container homes alone. By looking to these spaces to house student and low-income residents, the larger issues of affordability and housing scarcity may subsequently be addressed.



Figure 3.15: East Kowloon Office: Source: HKSAR Government

Some city officials argue that such a project is impractical and poses significant concerns for residents. "A commentator on Commercial Radio said that noise pollution, air pollution and lack of sunlight are practical disadvantages of these spaces, but there are psychological considerations as well. 'In many people's minds, living under a bridge is connected to homelessness,' he said" (Ko). However, many advocates say that these spaces may be an improvement over some existing housing stock and should be taken seriously by government officials. Mathias Woo, one of the program's supporters, contends that the creativity of urban designers and architects should not be underestimated, and that even the simplest proposals would likely be an improvement over some current housing designs. "Architects and designers could come up with lots of livable and innovative design ideas. There are many such sites in Hong Kong that we should explore rather sitting there and making judgments without any knowledge about design in a Hong Kong context" (Ko).

Under Bridge Action highlights the success of the Energizing Kowloon East Office, a district government affairs office, as an example of the feasibility of such projects. The office utilizes shipping containers stacked two stories high and organized in a square to create a central courtyard, with one of the Kwun Tong overpass's support towers acting as the centerpiece for the center. The group contends that if such a structure is permissible for housing workers, then they should also be reasonable for inhabitants.

Prototypical Uses

Stitch Competition, American Institute of Architecture

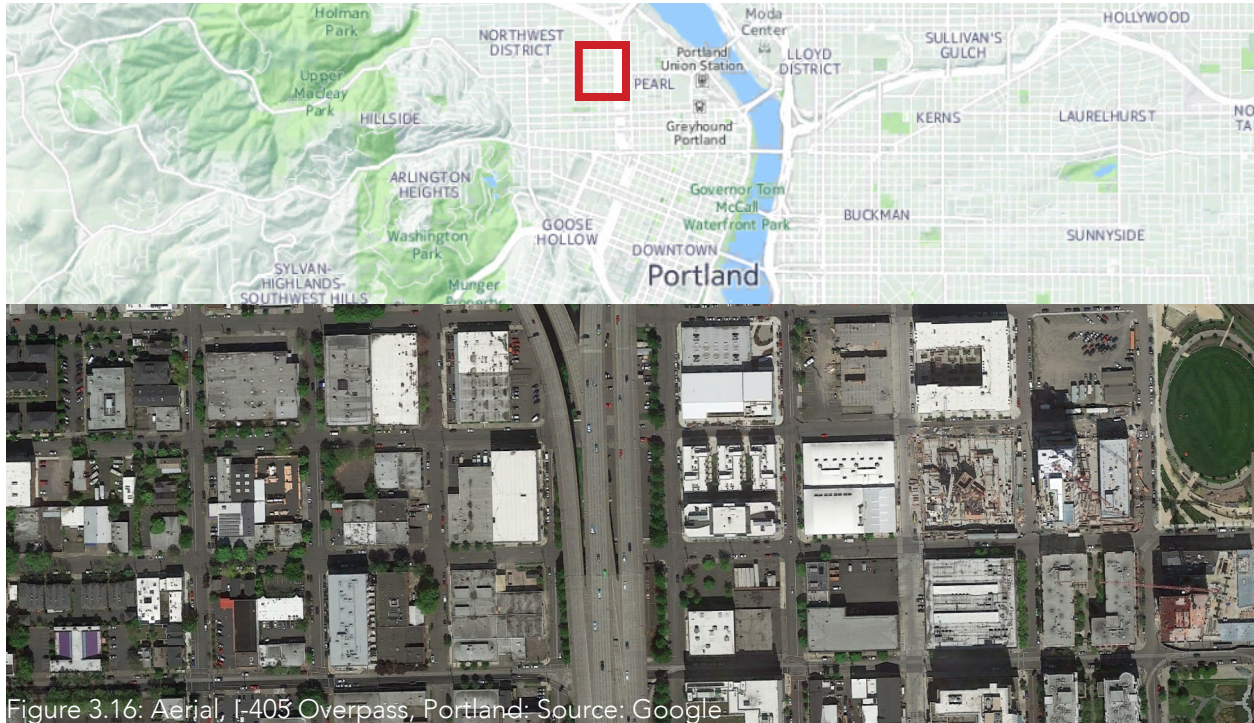

For the past two years, the Portland chapter of the American Institute of Architecture has held a competition that looks to develop the urban realm surrounding the city's Interstate 405 flyover. The freeway is perhaps the city's most significant artificial divide, effectively separating the Pearl District and downtown from neighborhoods to the west. In 2014 judges analyzed proposals to cap or build over the overpass. In 2015, the competition changed its focus from the area above the structure to the spaces adjacent to and below the freeway.

An excerpt from the competition's abstract provides insight as to why it is vital to examine liminal spaces in the modern city. "Density in the urban environment drives a need for the community to consider often-overlooked spaces created by infrastructure as infill potential. Modern vehicle conveyance structures create a natural shelter from the elements and a typically 'undesirable' area. We pass through or feel threatened by their cold and brutal existence" (Libby). By looking to reshape such sites, the greater urban realm should improve as well.

The competition's 2015 winner, *Unclouded Vision*, was developed by the city's own Opsis Architecture. Their proposal looked to create an area that would "provide

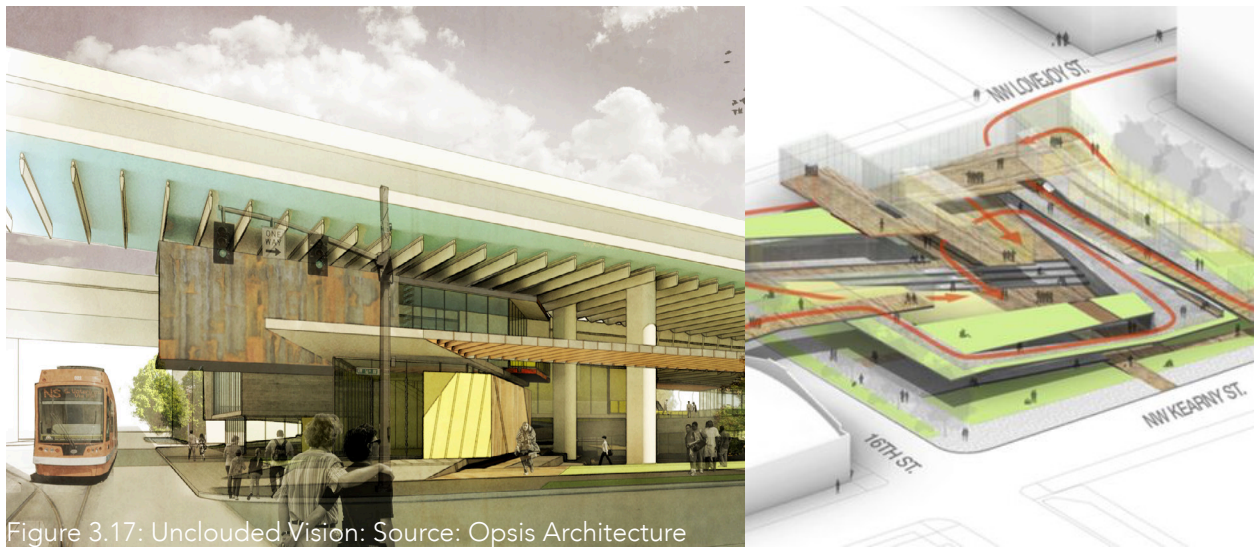

Figure 3.17: Unclouded Vision: Source: Opsis Architecture

transitional housing, temporary shelter and basic amenities to the homeless as well as connections to mentorship and job training and even a retail and community kitchen” (Libby). By integrating numerous amenities, such as “light harvesting systems, sound mitigating systems, pedestrian movement, commerce, food and public services”, the development would provide a habitable area for homeless residents.

Opsis’s proposal was created to help address the Portland metropolitan area’s continuing homelessness crisis. Since 2007, the regional homeless population has increased slightly, while the national trend has declined by nearly 11 percent. A lack of affordable housing is thought to be the main culprit: “Because of well-intentioned decisions made by well-meaning policymakers, Portland lacks enough permanent housing — the foundation of the 10-year plans — and enough emergency shelter space. Backlogs plague every step in the system” (Griffin). By working to add housing inventory that is specially set aside for homeless individuals, Opsis’s proposal works to address the needs of the city’s most vulnerable while reinvigorating an underutilized plot of urban land. Such a project shows that even the most creative and grand design interventions for covered liminal spaces can work to serve the needs of the disenfranchised.

Each of these precedents presents a unique approach that looks to utilize the liminal spaces of a city. While some emerged organically in response to a community need, others were developed as formal design interventions that attempt to employ otherwise derelict urban space. More often than not they work to serve the needs of the city's poor and disenfranchised, coming to be regarded as not just helpful but vital elements of survival. These examples come from across the world, showing up in smaller western cities like Portland, Oregon, as well as developing mega-cities like New Delhi and Hong Kong. An international city like Seattle that prides itself on innovative design and technology should easily lend itself to becoming the next candidate to engage these liminal spaces, particularly as centers of shelter for the city's disenfranchised.

Chapter 4

Encampment Research Study



Figure 4.1: Othello Encampment Construction. Source: Ken Lambert/The Seattle Times

Seattle Siting Process

Seattle is one of the few major American cities that has developed land use code to guide the location and management of homeless encampments, reflecting the City's commitment to the utilization of encampments in addressing homelessness. Frustrations with the shortcomings of current housing safety nets are made clear within the opening paragraph of the Department of Planning and Development's Transitional Encampments Ordinance 124747: "The current crisis of homelessness is impacted by a broad number of other societal challenges, including the growth of poverty and inequality, and the erosion of state and federal investments in our criminal justice, mental health, substance abuse, foster care and safety net systems, which have compounded in a crisis that requires the response of not just government, but by our entire community" (1). By acknowledging that every potential form of action should be considered, the City has been able to take an innovative approach with the permission and regulation of encampments. The evolution of this method can be traced back to the fall of 2010, when a Citizen Review Panel on Housing and Services for Seattle's Unsheltered Homeless Population recommended the development of encampments to provide emergency shelter to the recently homeless. In May 2011 the city council adopted Resolution 31292, containing the following approaches:

- *Working with faith-based communities to support the creation of shelter space on their properties or on City land leased by churches;*
- *Locating an encampment at a site... that, preferably, would not require any Comprehensive Plan or Land Use Code amendments; and*
- *Modifying the City's existing shelter services contracts to incorporate new best practices and address any shortcomings identified by the Human Services Department (HSD) and the Council (Office of Housing 1).*

These approaches were the City's first real steps in providing government support for the creation of homeless encampments. Recommendations were set forth for sanctioned homeless encampments, which would later be adopted into the Seattle Land Use Code. Resolution 31292 also provided guidance on how these encampments should be managed and the services that they should provide: "The Panel advised that the encampment be self-managed by its inhabitants in order to create opportunities for resident empowerment and to lower the cost of operating the encampment. It was strongly recommended that encampment managers provide residents with information

on how to access support services that would aid them in obtaining jobs, housing, and health care” (13).

In October 2011 the council passed ordinance 123729, which added a definition of “transitional encampment” to the land use code, as well as standards for locating encampments as an accessory use to religious facilities or to other principal uses on property owned or controlled by a religious organization. In 2012 Ordinance 123854 was passed, effectively amending the Human Development Element of the Comprehensive Plan and allowing for the City to guide the operation of transitional encampments to allow temporary shelter for those who are homeless. This made it possible for the city to consider the provision of public land for homeless encampments, as well as the management of camps by non-religious entities. However, it was not until March 2015 that finalized legislation allowing for the provision of transitional encampment use permits and the use of City-owned or private property was passed in the form of Ordinance 124747. This final ordinance details all legal requirements surrounding the establishment of encampments, including community outreach, operations standards, location, liability, duration and timing.

Site Selection Process

Ordinance 124747 established requirements for the City’s site selection process, including zoning, screening, geography, and access. The requirements are as follows:

1. *The property is:*
 - *Zoned Industrial, Downtown, SM, NC2, NC3, C1, or C2; except if the property is in a residential zone as defined in Section 23.84A.048 or is in a special review district established by Chapter 23.66; or*
 - *Within a Major Institution Overlay district.*
2. *The property is at least 25 feet from any residentially-zoned lot.*
3. *A property may be less than 25 feet from a residentially-zoned lot and used as an encampment site if:*
 - *All encampment facilities, improvements, activities, and uses are located at least 25 feet from any residentially-zoned lot. Access to the encampment site may be located within the 25-foot setback area; and*
 - *Screening is installed and maintained along each encampment boundary, except boundaries fronting on an opened public street. The screening shall consist of existing or installed vegetation that is sufficiently dense to obscure viewing the encampment site, or a 6-foot*

high view-obscuring fence or wall.

4. *The property is owned by the City of Seattle, a private party, or an Educational Major Institution.*
5. *The property is within 1/2 mile of a transit stop. This distance shall be the walking distance measured from the nearest transit stop to the lot line of the lot containing the encampment site.*
6. *The property is, as measured by a straight line, at least 1 mile from any other legally-established transitional encampment interim use including encampments accessory to a religious facility or accessory to other principal uses on property owned or controlled by a religious organization. This subsection 23.42.056.A.6 shall not apply to encampments on sites owned or controlled by religious organizations, or to any legally-established transitional encampment interim use that provides shelter for fewer than ten persons.*
7. *The property is 5,000 square feet or larger and provides a minimum of 100 square feet of land area for each occupant that is permitted to occupy the encampment site.*
8. *The property does not contain a wetland, wetland buffer, known and potential landslide designations, steep slope, steep slope buffer, or fish and wildlife habitat conservation area defined and regulated by Chapter 25.09, Regulations for Environmentally Critical Areas, unless all encampment facilities, improvements, activities, and uses are located outside any critical area and required buffer as provided for in Chapter 25.09.*
9. *The encampment site is not used by an existing legally-permitted use for code or permit-required purposes including but not limited to parking or setbacks.*
10. *The property is not an unopened public right of way; or designated as a park, playground, viewpoint, or multi-use trail by the City or King County.*

In working within the location requirements set forth by the ordinance, the City developed a site selection process that inventoried all available city-owned vacant land, 135 parcels in total. These were then analyzed and narrowed down to a selection of six potential sites for the siting of three permitted encampments. This process used a combination of GIS analysis and field visits: "Additional review of aerial photos and critical areas maps indicated that many of the sites were critical areas or heavily vegetated or treed, and therefore not suitable for an encampment. In addition, 'underutilized' sites were often found to be in use such as for parking or storage.

(The City) generally focused on the vacant sites, then worked with departments to cross-check availability. Further analysis was conducted to determine transit access, and whether or not the sites met the minimum encampment size” (Sugimura). The City then went through three rounds of evaluation, from the initial 135 in round one, to 27 “possible sites” in round two, to six final sites in round three. Sites were usually eliminated for the following reasons: dangerous topography, limited access, presence of critical areas, conflicts with current use, and the existence of rights-of-way through the site.

The City’s process is commendable in identifying the best vacant sites for encampment siting based upon multiple locational factors. However, little consideration is given to the desires of the potential residents during this process. In fact, the only guideline that works to provide a basic need for residents is the requirement that a site be located within 1/2 of a transit stop. It is the operators of the encampment who are responsible for providing basic needs and services for residents. This makes the site identification potentially flawed, for while it works to serve the desire of the City by employing least-utilized tracts of vacant land, it may do little to provide for the residents themselves. A more robust site selection process should instead be considered that takes into consideration the needs of the homeless, such as proximity to service centers. It is this shortcoming that I attempt to address in the site selection process for covered liminal spaces, detailed in the next section.



Figure 4.2: Author volunteering with LIHI: Source: Osato Cooley

Proposed Siting Process

The main goals of the data gathering efforts for this thesis were to document functional liminal spaces within the city of Seattle, to measure the performance of these sites in providing for their potential residents, and to gain perspective on the quality of these sites in comparison to current city-sanctioned encampments. Initial suitability scores were calculated based upon two categories: Performance, which includes access to services and transit quality, and Current Site Use. A final score was applied to each potential site and ranked from most to least suitable for hosting a homeless encampment. Three suitable sites identified in the initial analysis rounds were then chosen for site visits.

In attempting to score the performance of different encampment sites, I used the City of Seattle's Ordinance 124747 as a starting point in developing site requirements. After applying relevant code conditions, individual sites were evaluated based upon their proximity to homeless service centers, the strength of nearby public transit facilities, and the current use of the space.

Encampment Site Requirements

City of Seattle Requirements

Using the City of Seattle's Ordinance 124747 regarding the permitting of homeless encampments, I pulled any relevant information regarding encampment site needs that could be applied to my site location process. While requirements restricting locations through zoning requirements, setback needs, etc. exist, I was concerned foremost with language that directly addresses the needs of a site in providing for its residents. This includes the following stipulations:

- *The property is within 1/2 mile of a transit stop. This distance shall be the walking distance measured from the nearest transit stop to the lot line of the lot containing the encampment site.*
- *The property is 5,000 square feet or larger and provides a minimum of 100 square feet of land area for each occupant that is permitted to occupy the encampment site.*

The following restrictions on locations were adhered to in order to limit any obviously negative consequences in the utilization of certain sites:

- *The property does not contain a wetland, wetland buffer, known and potential landslide designations, steep slope, steep slope buffer, or fish and wildlife habitat conservation area defined and regulated by Chapter 25.09, Regulations for Environmentally Critical Areas, unless all encampment facilities, improvements, activities, and uses are located outside any critical area and required buffer as provided for in Chapter 25.09*

Any remaining restrictions dictating zones, screening, etc. were not applied to potential sites as they could effectively limit the study's effectiveness.

Applied Additional Requirements

In developing sites that work to best serve homeless residents, a number of additional needs were identified for the site selection process, as well as a modification to the city's half-mile transit stop access requirement.

Transit Score

The City of Seattle's requirement that encampments be located within one-half mile of a transit stop is a reasonable baseline for providing transportation options for residents that are less likely to own a personal car, but it falls significantly short of meeting the often-cited standards for pedestrian-transit access. Encampments should instead be located within ¼ mile of a transit stop rather than 1/2 mile to better accommodate residents. According to the Transportation Research Board, the majority of bus users (75-80%) will walk one-quarter mile or less to access a bus stop (Kittelsohn). Additionally, King County Metro's Service Guidelines state that any service restructures should work to create maximum walk distance goal of 1/4 mile in corridors where service is not primarily oriented to freeway or limited-access roadways (King County). It makes little sense to locate encampments and their residents up to one half mile from a transit stop when the standard rationale recommends no greater than a 1/4-mile walkshed for planning transit routes. Thus, a 1/4-mile walkshed is used to capture the number of potential bus stops near an encampment to ensure robust transit access.

While it is important to identify bus stops that are in close proximity to a potential

encampment site, this information reveals little about how adequate transit service in an area may be. In order to calculate and score a potential site's transit service levels, I collected discrete scores using Walk Score's Transit Score® service. The methodology for this scoring system is described on the organization's website as follows:

Transit Score is a patented measure of how well a location is served by public transit on a scale from 0 to 100.

Transit Score® Description

- 90–100 *Rider's Paradise*
World-class public transportation.
- 70–89 *Excellent Transit*
Transit is convenient for most trips.
- 50–69 *Good Transit*
Many nearby public transportation options.
- 25–49 *Some Transit*
A few nearby public transportation options.
- 0–24 *Minimal Transit*
It is possible to get on a bus.

The Transit Score algorithm calculates a score for a specific point by summing the relative "usefulness" of nearby routes. We define usefulness as the distance to the nearest stop on the route, the frequency of the route, and type of route. Transit Score works in any city where the transit agencies publish data in the GTFS format.

Calculating the Raw Transit Score

To calculate a raw Transit Score, we sum the value of all of the nearby routes. The value of a route is defined as the service level (frequency per week) multiplied by the mode weight (heavy/light rail is weighted 2X, ferry/cable car/other are 1.5X, and bus is 1X) multiplied by a distance penalty. The distance penalty calculates the distance to the nearest stop on a route and then uses the same distance decay function as the Walk Score algorithm.

Normalizing Scores from 0 to 100

Since any measure of transit infrastructure (number of stops, number of weekly trips, etc.) will have its own unique range, it is necessary to normalize the raw Transit Score to generate a Transit Score from 0 to 100.

The amount of transit infrastructure can vary by several orders of magnitude. Scales for measuring things that have an extremely large range of normal values (sound volume, earthquake intensity, etc) are typically logarithmic - a bus stop in a small town might see three trips a day, whereas downtown Manhattan might see tens of thousands. If Manhattan had a Transit Score of 100, then on a linear scale a small town's downtown might have a Transit Score of 0.01, whereas a logarithmic score might rate Manhattan as 100 and a small town as 10. The logarithmic score matches a rider's experience better: the added utility of one additional bus in a small town may exceed the addition of 10 new routes in downtown Manhattan.

In order to normalize from 0 to 100, we need to pick a "perfect score" location. To do this, we averaged the Transit Score of the center of a five U.S. cities where we had full transit data (San Francisco, Chicago, Boston, Portland, and Washington, D.C.) to create a canonical 100 Transit Score.

By calculating transit scores for each site, I was able to develop a better picture of how well connected a site may be to the rest of the region. A site with a higher score equates to more convenient access for residents, be it to employment centers, service centers or general amenities, in turn making it a more desirable location to site a homeless encampment.

Service Centers Score

In determining the convenience of a site's location, I scored existing and potential encampment locations based on their proximity to service centers that work to serve the homeless. By locating encampments within close proximity to service centers, ease of access should be significantly improved. An understanding of nearby services may also aid potential residents in choosing between different sites based on their personal needs.

According to the 2009 Seattle Homeless Needs Assessment (SHNA), a homeless population survey conducted by the city of Seattle, the following services were identified and ranked by their utilization rate based upon surveys conducted with homeless individuals :

- Food Banks 70%

- Hygiene Centers 53%
- Meal programs 48%
- Shelter 37%
- Health Care Services 34%
- Case Management 19%
- Community Voicemail 16%
- Employment program 14%

Using Washington State’s 2-1-1 Community Resources Database, I researched and created a database of Seattle service centers with geo-locatable addresses. Based upon the SHNA and the WA 2-1-1 site’s available search parameters, I developed five categories to capture service centers throughout the city:

- Food Bank / Soup Kitchens
- Mental Health Centers
- Substance Abuse Centers
- Family Services Centers
- Thrift Shops (This category was included to provide material needs for residents.)

Certain service groups identified in the SHNA were not considered for the following reasons:

- Shelter: the needs for shelter are addressed through the creation of an encampment, making such a category redundant.
- Hygiene centers: addressed within an encampment.
- Health care services: only acute service centers more directly tied to the needs of the homeless, such as mental health or substance abuse, were examined. Larger general health care centers such as hospitals or community medical centers were omitted.
- Community voicemail: utilization rate below 20%.
- Employment programs: utilization rate below 20%.

Following the creation of the five categories, I pulled addresses for every Seattle service center from the WA 2-1-1 database. These were then geo-referenced and pulled into ArcGIS.

In determining the number of service centers within a close proximity to current and

potential encampment sites, I applied a one-mile walking buffer to all sites. The reason for applying a one-mile buffer is due to the fact that people are often willing to walk longer distances to acute destinations like work or medical appointments versus to a transit stop (Larsen). At one mile the distance is often close enough to access without the assistance of transit or a vehicle. However, the distance decay curve (or willingness to walk) begins to drop off significantly after a mile, making such a walkshed size appropriate.

Service center scores were then tallied for each site. A multiplier for each category was applied equal to that of the utilization rates identified in the SHNA.

- Food Bank / Soup Kitchens x .7
- Mental Health Centers x .34
- Substance Abuse Centers x .34
- Family Services Centers x .19
- Thrift Shops x .14 (lowest utilization rate identified by SHNA).

As an example, a site with 10 food banks or soup kitchens within a one-mile walkshed would receive a score of 7 for that category: $10 * .7 = 7$. A site with 10 mental health centers would receive a score of 3.4: $10 * .34 = 3.4$. After identifying and rating all service centers within a one-mile walkshed the scores were aggregated, resulting in a final service centers score.

To develop a ranking score for each site, an omega score of 100 was set using the site with the greatest number of centers (i.e. the I-5 Cherry Street's 64 service centers). The values of the rank-ordered set were accordingly calculated as percentiles for each site, and given a score between 0 and 100. For example, the Fremont Bridge site has 8 service centers within one mile, providing it with a Service Center Score of 12.1 ($8/66 = .12, .12 * 100 = 12.1$).

Current Site Use Score

In acknowledging that some areas beneath bridges and overpasses may contain uses that are vital to the city and/or surrounding neighborhood, sites were also ranked dependent upon their current use. Sites that were deemed to be unutilized were given the highest score of 100, while those sites that were heavily utilized were given a score of 1. The following uses were applied to each ranking level.

- 100: Unutilized - Empty lot.
- 50: Somewhat Utilized - Storage area, under-capacity parking lot.
- 0: Utilized - At/over-capacity parking lot, any other use (artwork, park, etc.).

The aim in giving unutilized sites a higher score than those with parking lots, etc. is to encourage the early improvement of such vacant liminal spaces in the city. The likelihood of generating political or governmental opposition is also less likely in areas that are currently devoid of a purpose. However, just because a site may be unutilized does not mean it is incredibly appropriate for the siting of an encampment, which leads us to the final scoring process addressing such issues.

Final Score

To reiterate, the three scores tallied for a site are as follows:

1. Service Centers Score
2. Transit Score
3. Current Use Score

In order to give equal weighting to each score, a multiplier of $1/3$ was applied to each site's three separate scores. These scores were aggregated and then multiplied by 100, resulting in a site's final score. Final scores were then ranked from greatest to least, with the two highest scoring sites being selected for field visits. A third site was chosen at random to provide additional site insights. Design interventions were subsequently developed for each of the sites based upon these visits.

Figure 4.3: Current Seattle Encampment Sites

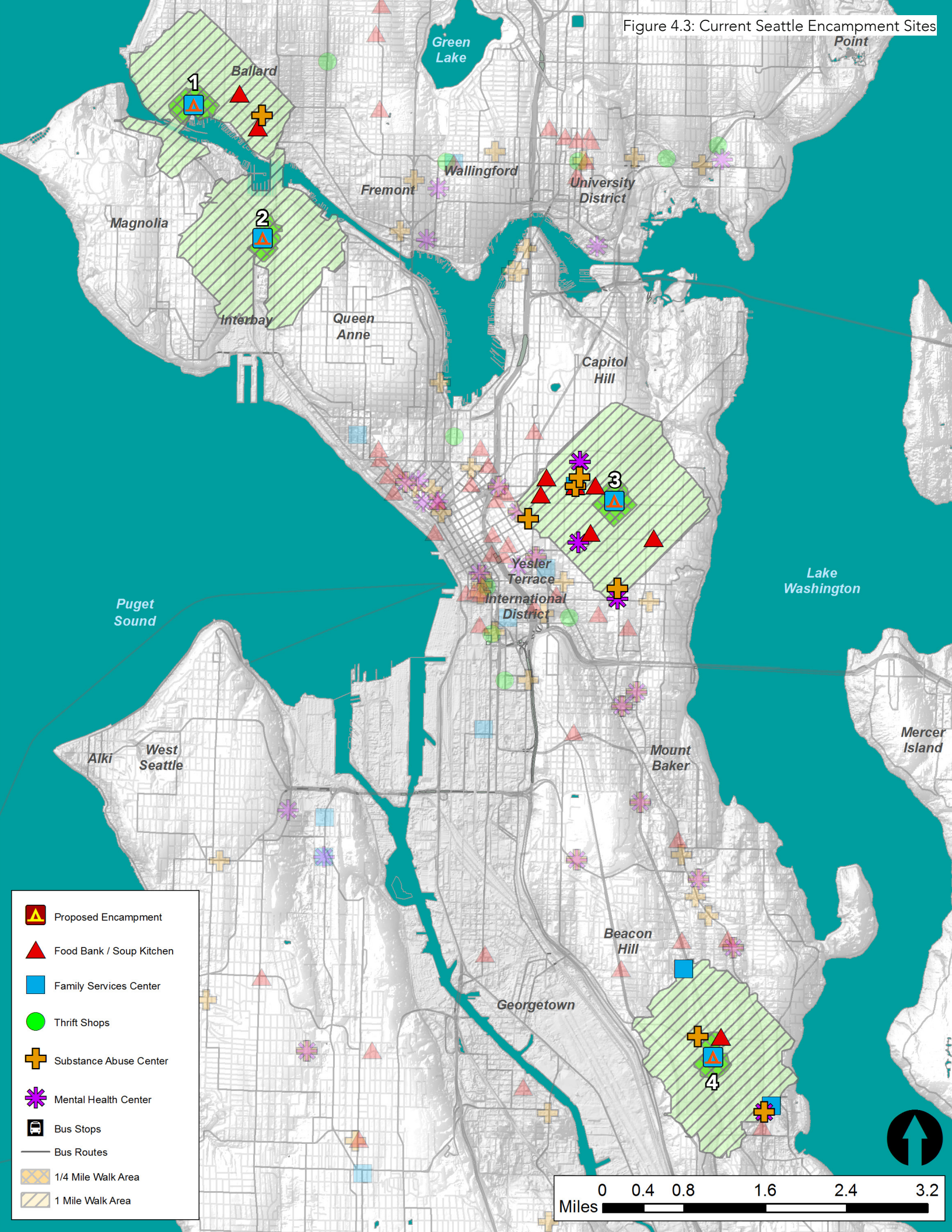

- Proposed Encampment
- Food Bank / Soup Kitchen
- Family Services Center
- Thrift Shops
- Substance Abuse Center
- Mental Health Center
- Bus Stops
- Bus Routes
- 1/4 Mile Walk Area
- 1 Mile Walk Area

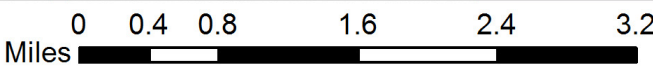

Current Encampment Sites

As of March 2016 there were four city-sanctioned homeless encampments within the city of Seattle as listed by the Low Income Housing Institute:

1. Ballard Encampment, 2826 NW Market Street

52 residents

Parcel Owner: City of Seattle

Management Group: Nickelsville

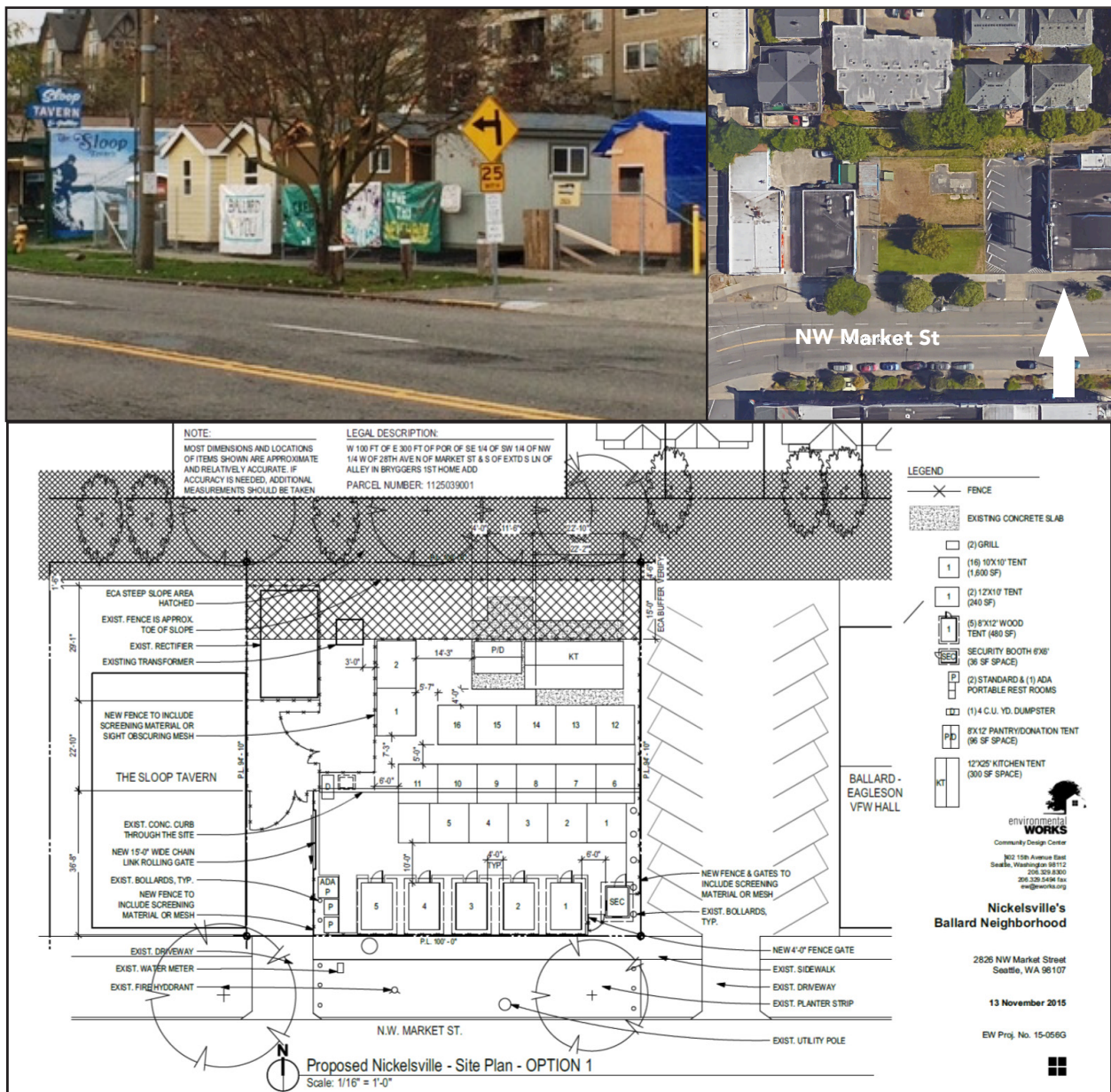

Figure 4.4: Ballard Encampment: Source: LIHI

2. Interbay Encampment: 3234 17th Avenue W

53 residents

Parcel Owner: City of Seattle

Management Group: Seattle Housing and Resource Effort

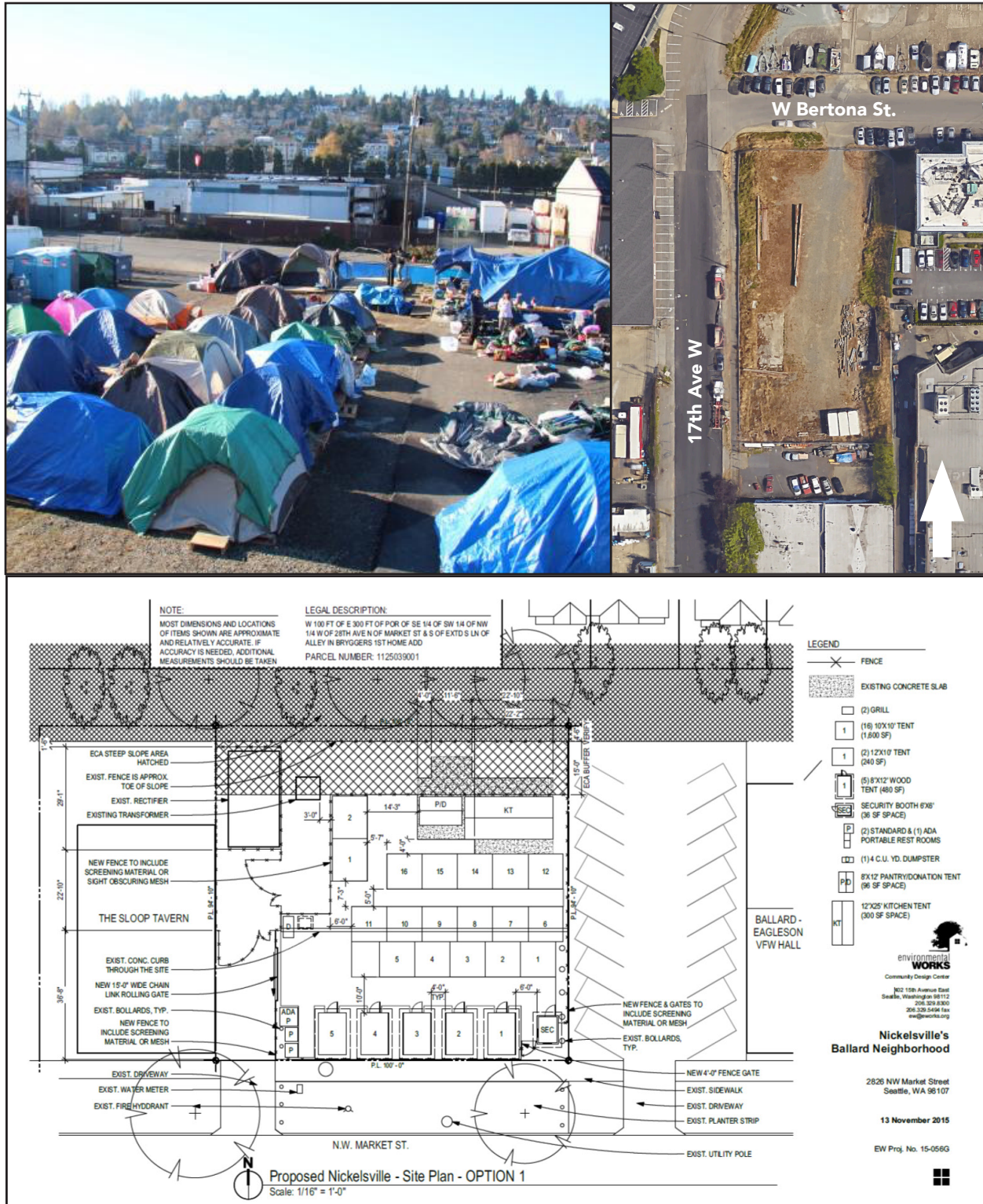

Figure 4.5: Interbay Encampment: Source: LIHI

3. Tiny House Village: 1419 22nd Avenue

30 residents

Parcel Owner: Lutheran Church of the Good Shephard

Management Group: Nickelsville



Figure 4.6: Tiny House Village: Source: LIHI

4. Othello Village: 7544 Martin Luther King Jr. Way S

60-80 residents

Parcel Owner: City of Seattle

Management Group: Nickelsville

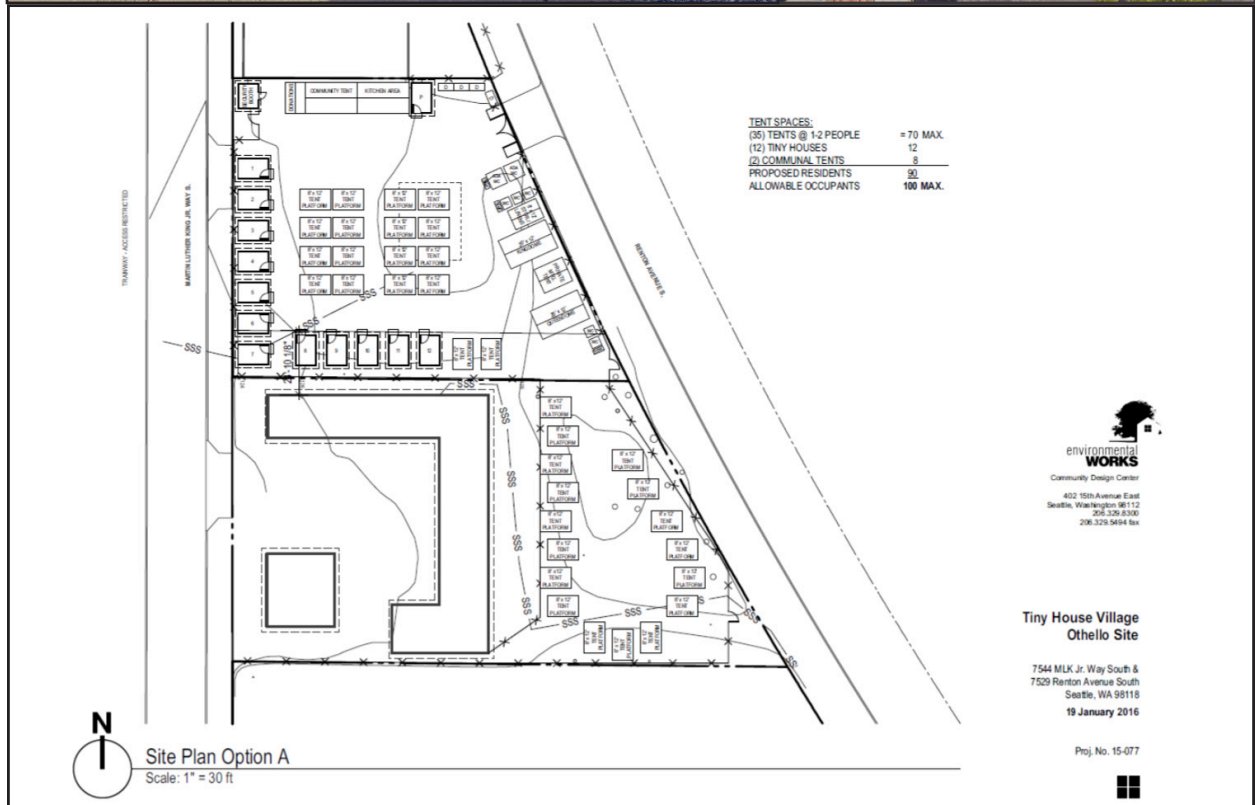

Figure 4.7: Othello Encampment: Source: LIHI

The four encampments are all organized in accordance with the City of Seattle's rules for encampment siting and size; each site is located more than one mile apart from one another, within a half-mile of a transit stop, and sited on a lot of 5,000+ square feet. Three of the four sites were chosen through the city's selection process, while the Tiny House Village is hosted by the Lutheran Church of the Good Shephard. The first encampment locations opened were the Ballard and Interbay sites in November 2015, followed by Tiny House Village in January 2016, and the Othello location in March 2016.

The site analysis that I applied to potential liminal spaces was applied to LIHI's encampments to offer a comparative analysis of current and potential locations. This included reducing the transit stop walkshed from one half mile to one quarter mile and analysis of services located within a one mile radius buffer.

Service Centers Scores

A total of nineteen service locations were identified within all one mile walksheds:

- 8 Food Banks
- 7 Substance Abuse Centers
- 3 Mental Health Centers
- 2 Family Services Centers
- 0 Thrift Stores

The greatest concentration of services was around the Tiny House Village, with twelve different centers located within a one mile distance. The least served location was the Interbay Encampment, with zero service centers located within a reasonable walking distance. Such results are not surprising, for services are often located in areas with greater population and job density. The Interbay site is located in a largely industrial section of the city between residential neighborhoods, while the Tiny House Village is located in the Central District near downtown Seattle.

Taking the average of each service center category for these sites (service centers/ number of sites), we can develop an idea of what a typical encampment might look like. Within a one mile walking distance, the average encampment would have the following number of services nearby:

- 2 Food Banks

- 1.75 Substance Abuse Centers
- .75 Mental Health Centers
- .5 Family Services Centers
- 0 Thrift Stores

Service Centers Scores for each encampment are as follows:

- Ballard Encampment: 16.33
- Interbay Encampment: 16.67
- Tiny House Village: 21.33
- Othello Village: 21.00

Transit Scores

Using Walkscore’s Transit Score calculator, the following scores were tallied for each site:

- Ballard Encampment: 49
- Interbay Encampment: 50
- Tiny House Village: 64
- Othello Village: 63

Current Site Use Scores

Due to the fact that every existing encampment is either located on vacant land owned by the City or the Lutheran Church of the Good Shepherd, each site was given the highest possible Current Use Score of 100.

Final Scores

Using the developed scoring methodology, the following final scores were calculated:

Looking at these results, it appears that the Tiny House Village performs best with an overall score of 63.52. This is due largely to the site’s close proximity to a number of nearby service centers, twelve in total. It also received the highest Transit Score, reflecting the site’s proximity to a significant number of major transit routes. The Interbay Encampment ranks lowest due to lower transit access and its significant

isolation from service centers. These scores provide a helpful baseline for measuring a new site's overall performance, be it the potential sites identified in this thesis or any future sites to be considered by the City of Seattle.

Figure 4.8: Liminal Space Inventory

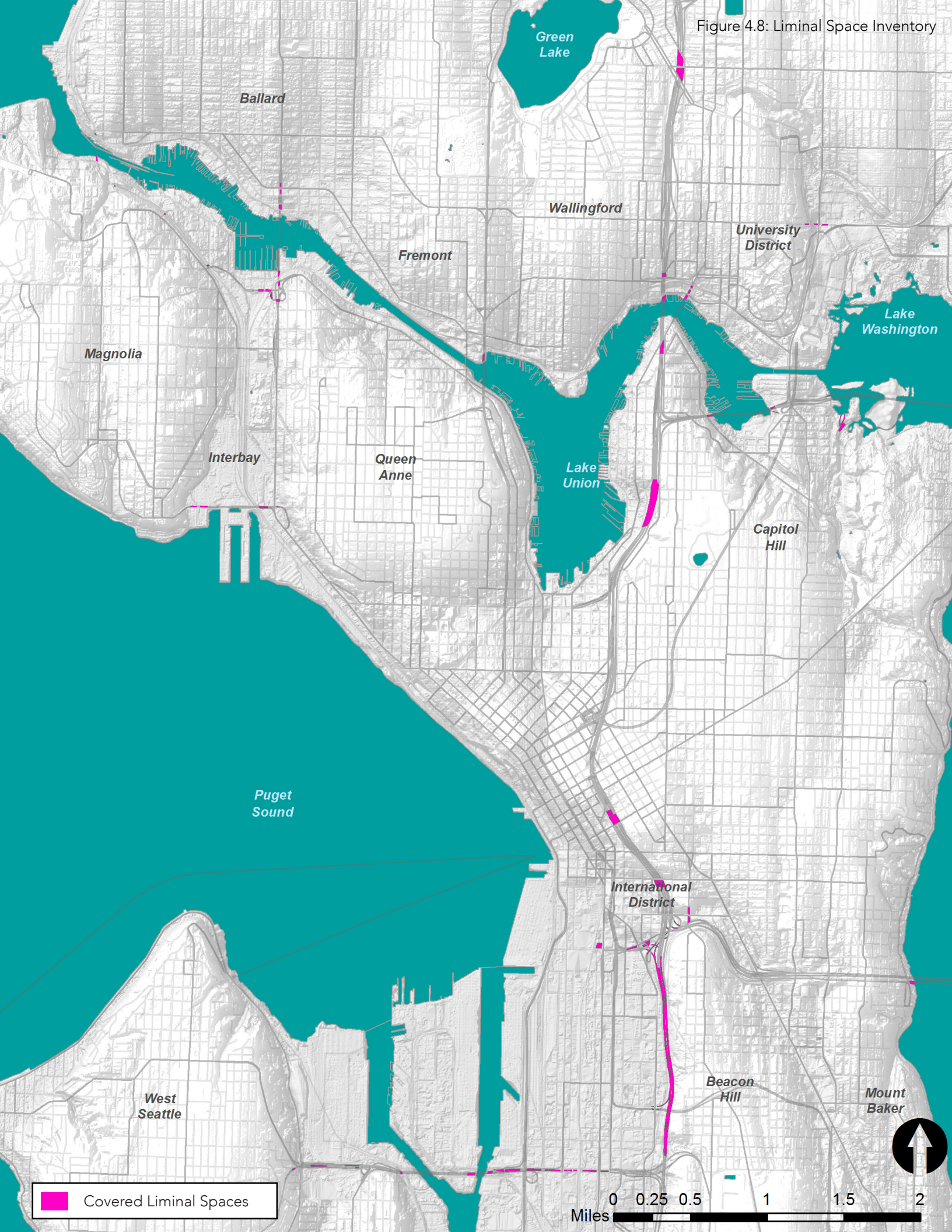

Potential Encampment Sites

In working to identify and analyze covered liminal spaces within the city that may have the capacity to host homeless encampments, an initial liminal spaces inventory was developed. Using information provided by the Washington State Department of Transportation's state bridge inventory and the Seattle Department of Transportation's Bridge Sufficiency Rating list, all elevated transportation structures within the city of Seattle were geo-located and compiled within a GIS geodatabase. These WSDOT and SDOT databases are limited in the structural information they provide, often only providing information as to the location, age and safety rating of a structure. Little to no information regarding the spaces beneath these structures was available, forcing me to develop a geodatabase detailing the location and extent of potentially viable spaces from scratch.

In order to develop a covered spaces inventory (CSI), I first used the database information provided by SDOT and WSDOT to locate sites within the city. Using a combination of Google Earth/Streetview, Apple Maps, Bing Maps and preliminary site visits, I developed rough estimates of covered space extents within Seattle. Sites that presented hindrances that were obviously too difficult to overcome were omitted during this first round of identification. Examples of such difficulties included spaces that were too small or mostly uncovered, covered areas that could not be easily utilized (waterways, railroads, etc.), inaccessible sites such as active industrial zones (i.e. the Port of Seattle), etc. Overpass sufficiency ratings were also noted, with those sites near structures below the City's critical safety threshold rating of 35 omitted. Moving from the original bridge inventory, a total of 72 sites were identified and mapped. Many of these sites were clustered near one another around particularly large infrastructure projects, such as the I-5/I-90 interchange and the Spokane Street Viaduct. For the purposes of this analysis, discernable sites that were separated by features like a street or barrier were given a unique identifier, rather than amalgamated.

After the initial CSI was developed, a second round of omission was undertaken to reduce the number of sites from the initial assessment to those that could be more justifiably considered for encampment siting. This included exclusion of sites that may be inaccessible or slated for destruction during the time this study was undertaken, such as the approaches to the old SR-520 bridge, the majority of which were off-limits due to the area's use as an active construction site for the new SR-520 bridge.

It also included omission of sites that could be seen as too politically contentious or unmanageable to be practically considered. An obvious case would be that of the area known as “the Jungle”.

The Jungle is a 3 mile long, 150 acre large site located beneath Interstate 5 on the western slopes of Beacon Hill. It is home to an estimated 210 identified camp sites and potentially 400+ homeless residents. The area has been a part of Seattle’s landscape for many years, with some residents claiming to have lived there for a number of decades. In recent years it has become an increasingly dangerous and contentious space for the city. A shooting event in January 2016 that left two homeless dead and three injured has spurred calls for officials to clear the site and fence the area off entirely. Concerns include potential risks to the greater public, such as storage of illicit materials within the space and uncontrolled fires that can damage the structure above. Accessibility for health and emergency crews is a difficult issue to overcome due to the geography and magnitude of the site as well. In fact, the King County One Night Count avoided the Jungle entirely in 2016, citing safety concerns for volunteers. Due to my own inability to gain access into and take assessment of the site, as well as the current state of public opinion surrounding the issue, I came to conclusion that omitting the area from study was the only practical course to take.

Following the initial site analysis, 34 sites remained across the city of Seattle for consideration as potential encampment locations. Fortunately for the study, these sites were spread relatively evenly across neighborhoods, providing a diverse inventory with which to complete the third round of analysis: site performance scoring.

**Note: Elevation profiles were intended to be included in the preliminary site inventory to gain an idea of whether a potential site may be too steep or varied for encampment siting. Unfortunately, any raster or elevation data provided by King County or the city of Seattle was unable to capture an accurate image of the slope in many sites. This was usually due to included features such as pilings or structural components that effectually distorted the data.*

Figure 4.9: Potential Liminal Space Encampment Sites

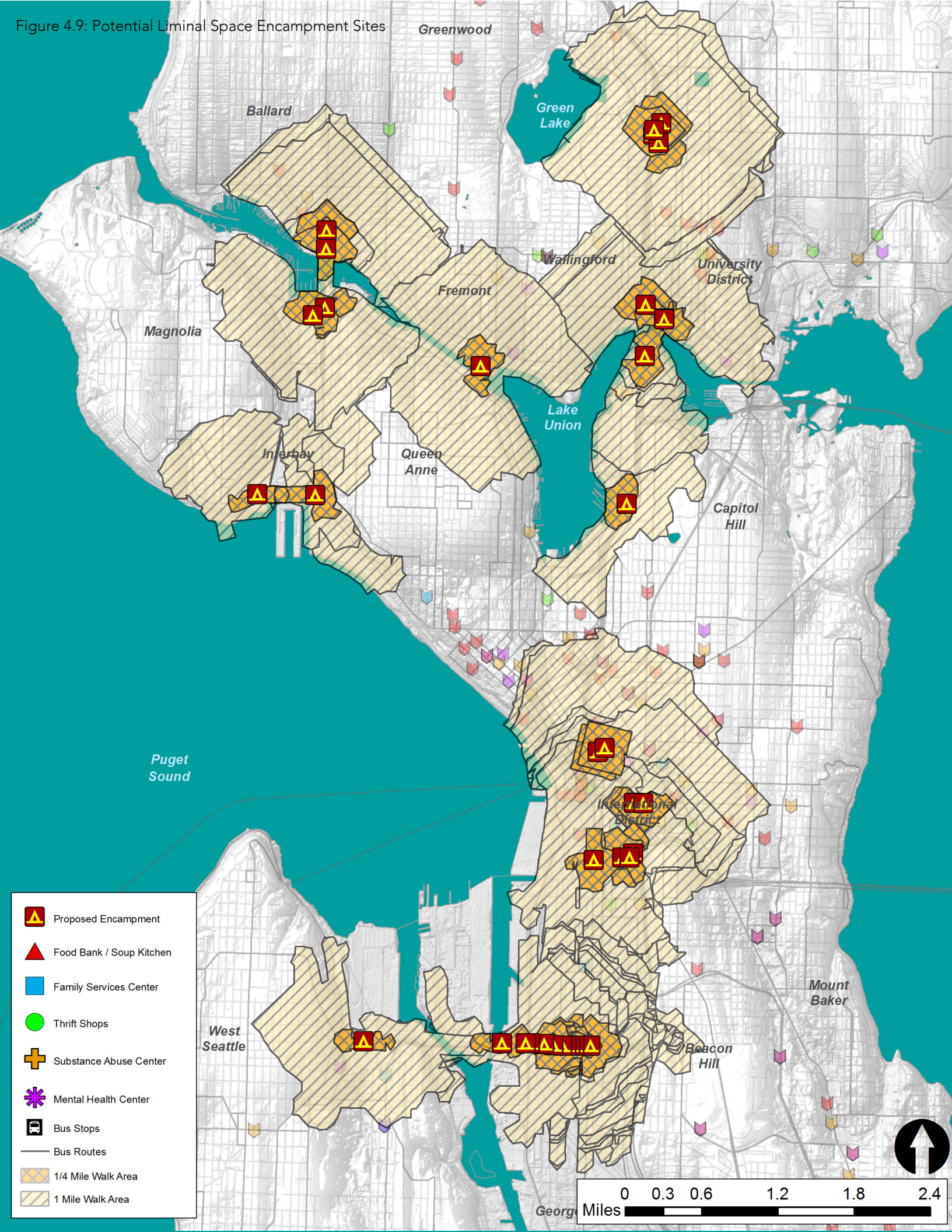

- Proposed Encampment
- Food Bank / Soup Kitchen
- Family Services Center
- Thrift Shops
- Substance Abuse Center
- Mental Health Center
- Bus Stops
- Bus Routes
- 1/4 Mile Walk Area
- 1 Mile Walk Area

0 0.3 0.6 1.2 1.8 2.4
Miles

Green Lake Park and Ride

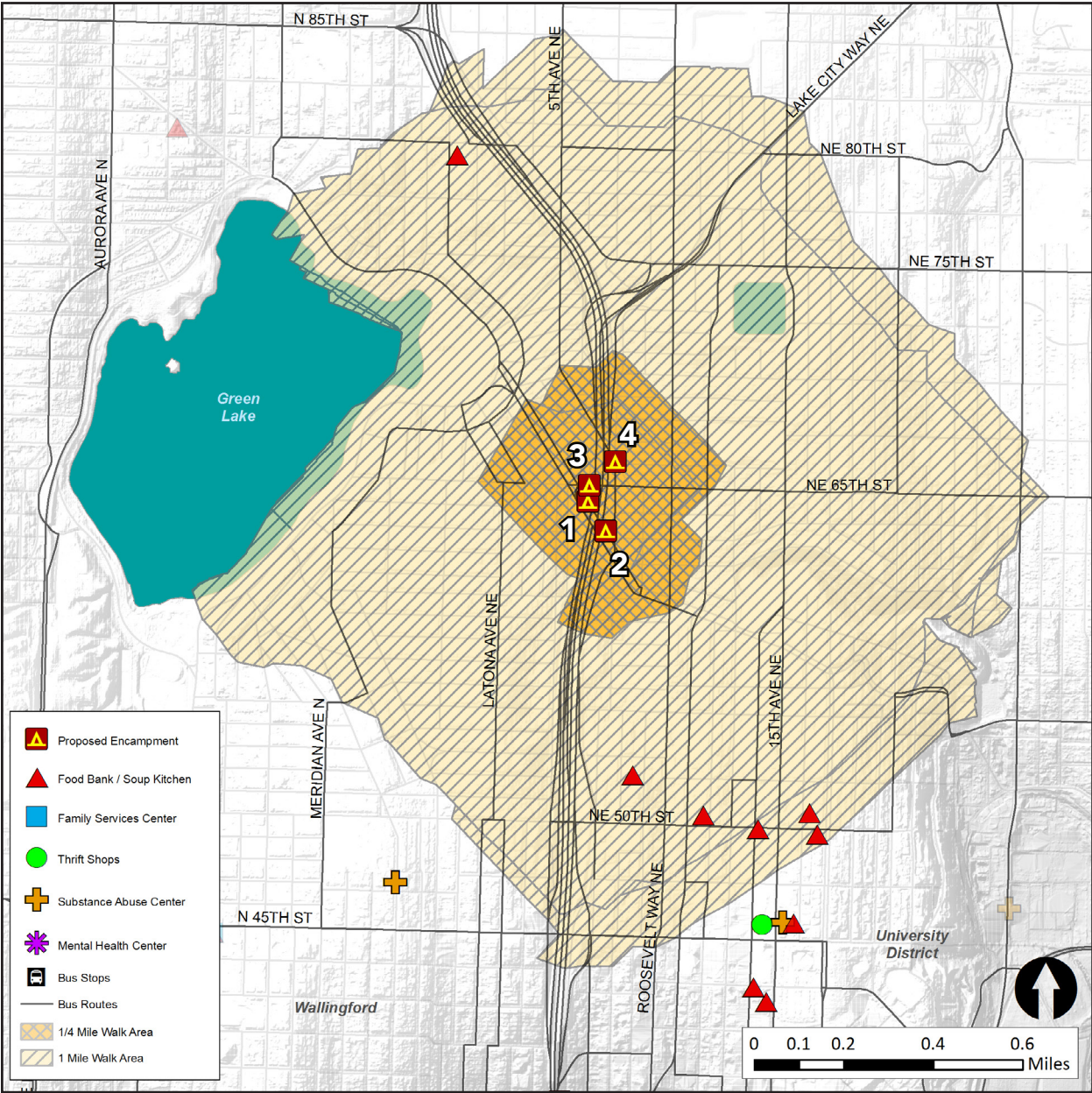

Figure 4.10: Green Lake Park and Ride Sites Map

Square Footage: 5,000 - 81,000

Owner/Operator: King County Metro

Overpass Sufficiency Rating (2012): 77.6

Notable Nearby Landmarks: Green Lake, Tangletown, University District

The Green Lake Park and Ride offers four potential sites for siting homeless encampments: two within the north and south parking lots themselves, one between the southern lot and Ravenna Boulevard, and one within the median of the boulevard itself. The twenty bus stops within a quarter mile offer plenty of travel options to potential residents, and the proximity to the park and ride makes for easier to access to regional buses as well. The one type of service identified in the neighborhood, food banks, offers many locations nearby. The park and ride itself is quite busy but not often above capacity, with observed utilization rates between 75 and 92 percent in 2010 (Puget Sound Regional Council). This may allow for the placement of an encampment within one of the lots itself without significantly impacting parking utility.

Current Use: Sites 1 and 2: Park and Ride Lot (Score: 0)		
Sites 3 and 4: Empty lot (Score: 100)		
¼ Mile Walkshed		
o Bus Stops:		20
1 Mile Walkshed:		
o Mental Health Centers:		0
o Substance Abuse Centers:		0
o Family Services Centers:		0
o Food Banks/ Soup Kitchens:		6
o Thrift Shops:		0
Area Transit Score:		19.33
Area Service Centers Score:		6.32
Current Use Score -	Sites 1/2:	33.33
	Sites 3/4:	0
Final Scores:	Sites 1/2:	58.99
	Sites 3/4:	20.95

Ballard Bridge

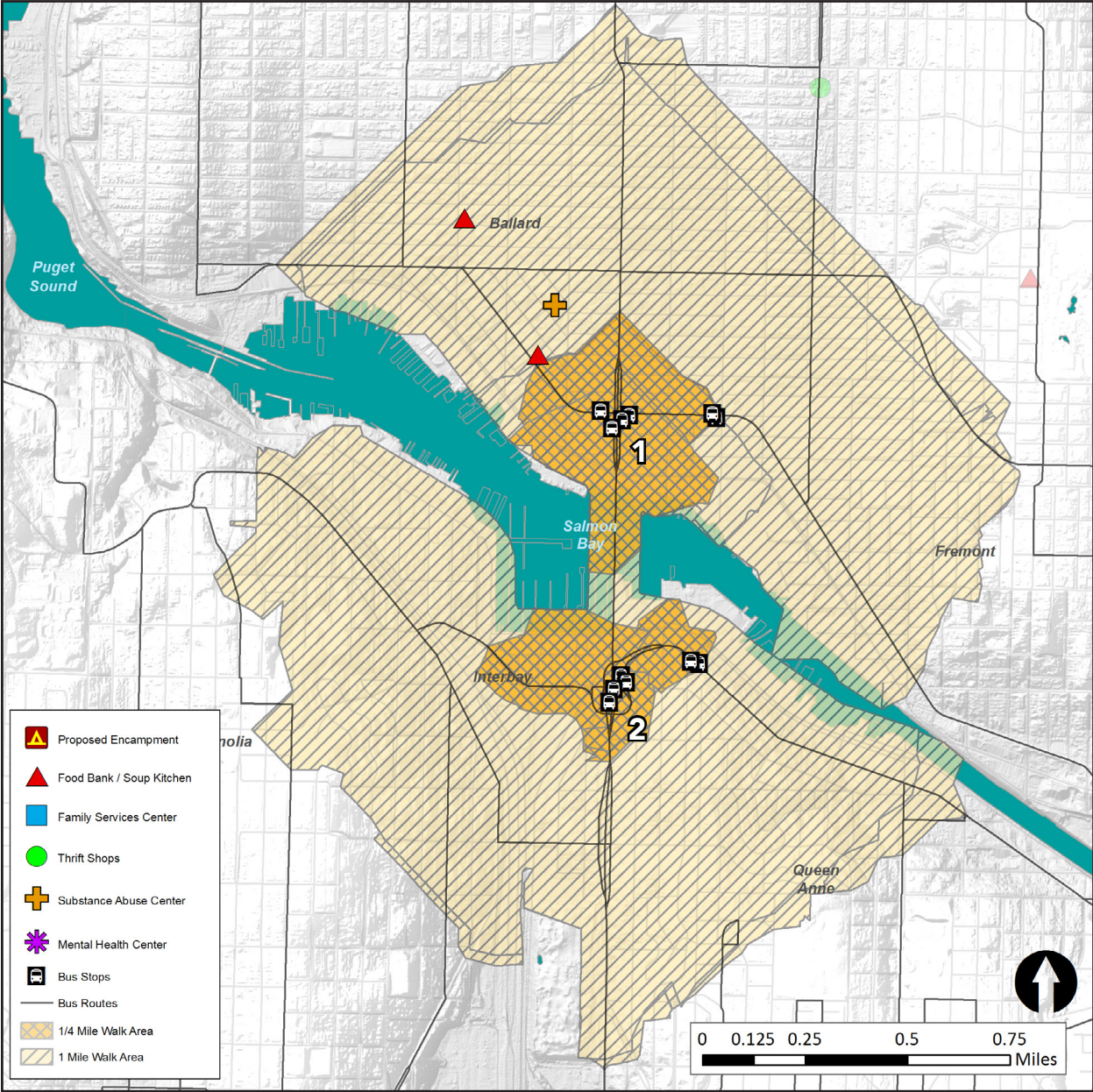

Figure 4.11: Ballard Bridge Sites Map

Square Footage: Site 1 - 13,500, Site 2 - 8,700.

Owner/Operator: Seattle Department of Transportation

Overpass Safety Rating (2012): 48.45

Notable Nearby Landmarks: Fishermen's Terminal, Chittendem Locks, Ballard Commercial District

The two identified sites are located underneath the concrete approaches to the Ballard basquale bridge. The northern site is currently fenced off and used for storage by SDOT, while the southern site remains vacant. While the sites are located within walking distance of the commercial center of Ballard, there are few services available to potential residents, with just two food banks and one substance abuse center within the one mile walkshed of the northern site. Both sites remain underutilized, however, and are well removed from more heavily used rights of way in the area.

Current Use: Site 1: SDOT storage (Score: 50)		
Site 2: Empty lot (Score: 0)		
¼ Mile Walkshed		
o Bus Stops:		12
1 Mile Walkshed:		
o Mental Health Centers:		0
o Substance Abuse Centers:		1
o Family Services Centers:		0
o Food Banks/ Soup Kitchens:		2
o Thrift Shops:		0
Area Transit Score:		18.33
Area Service Centers Score:		2.62
Current Use Score -	Site 1:	16.67
	Site 2:	0
Final Scores:	Site 1:	37.62
	Site 2:	20.95

Fremont Bridge

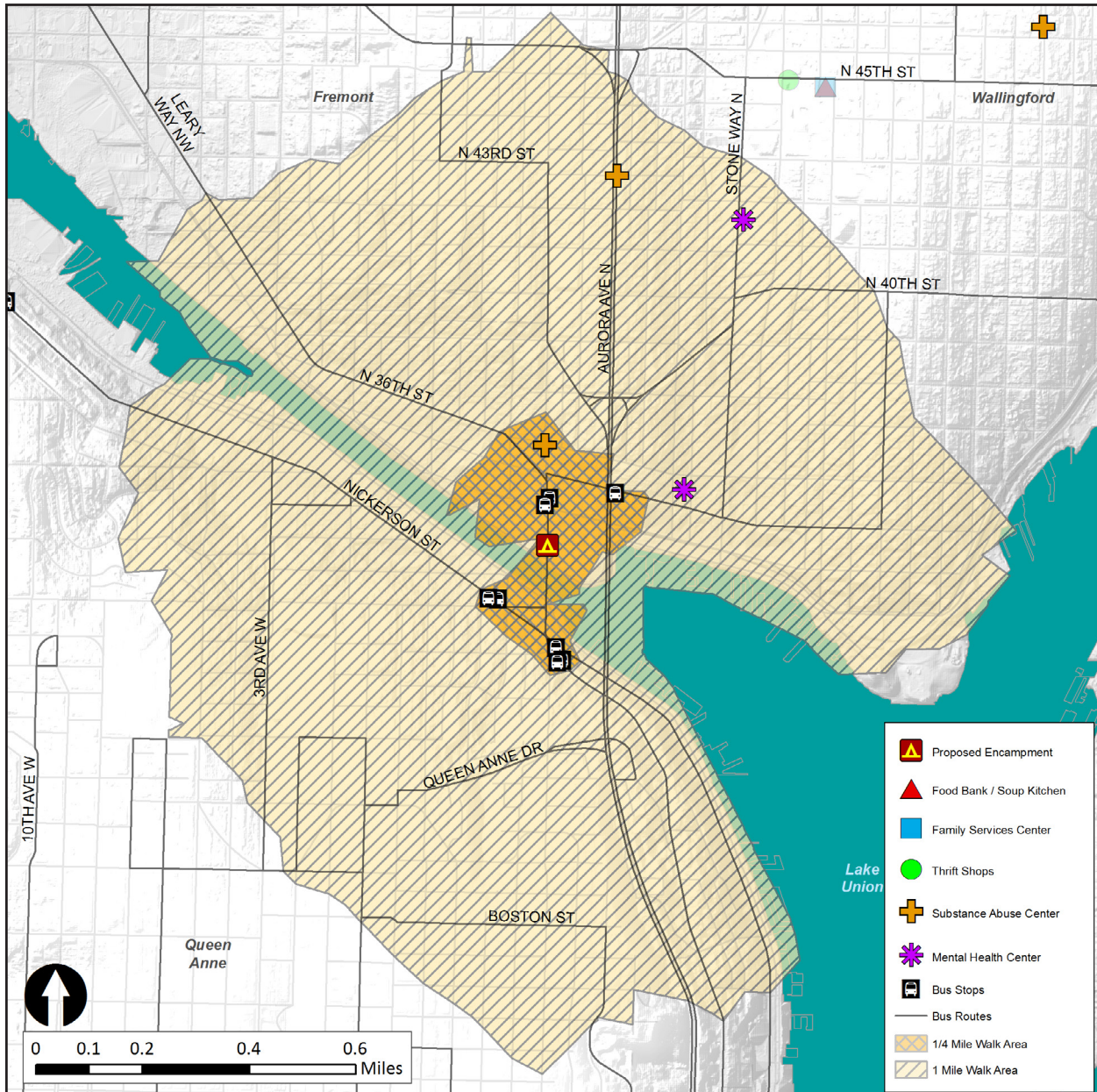

Figure 4.12: Fremont Bridge Sites Map

Square Footage: 6,000

Owner/Operator: Seattle Department of Transportation

Overpass Sufficiency Rating (2012): 71.08

Notable Nearby Landmarks: Aurora Bridge, Lake Union, Gasworks Park, Fremont

The site is located beneath the northern approach of the Fremont bridge, a structure that replaced the bridge's 1950s onramps in 2004. The site is currently occupied by a public parking lot that largely serves the office buildings on either side of the bridge. The location provides easy access to two substance abuse centers; Integrative Counseling Services and Island Assessment and Counseling Center. It is close to two mental health centers managed by the Community Psychiatric Center; one that focuses on housing issues/needs and the other providing community support services. The eight bus stops provide routes that travel in both north/south and east/west directions, making them convenient for potential riders. The lot is also adjacent to the Burke Gilman Bike Trail, providing easy bicycle access. The bridge itself is the country's busiest bascule (opening) bridge, making it a very active area.

Current Use: Utilized Parking Lot (Score: 0)	
¼ Mile Walkshed	
o Bus Stops:	8
1 Mile Walkshed:	
o Mental Health Centers:	0
o Substance Abuse Centers:	2
o Family Services Centers:	2
o Food Banks/ Soup Kitchens:	0
o Thrift Shops:	0
Area Transit Score:	20.33
Area Service Centers Score:	1.6
Current Use Score:	0
Final Score:	21.93

Portage Bay Region

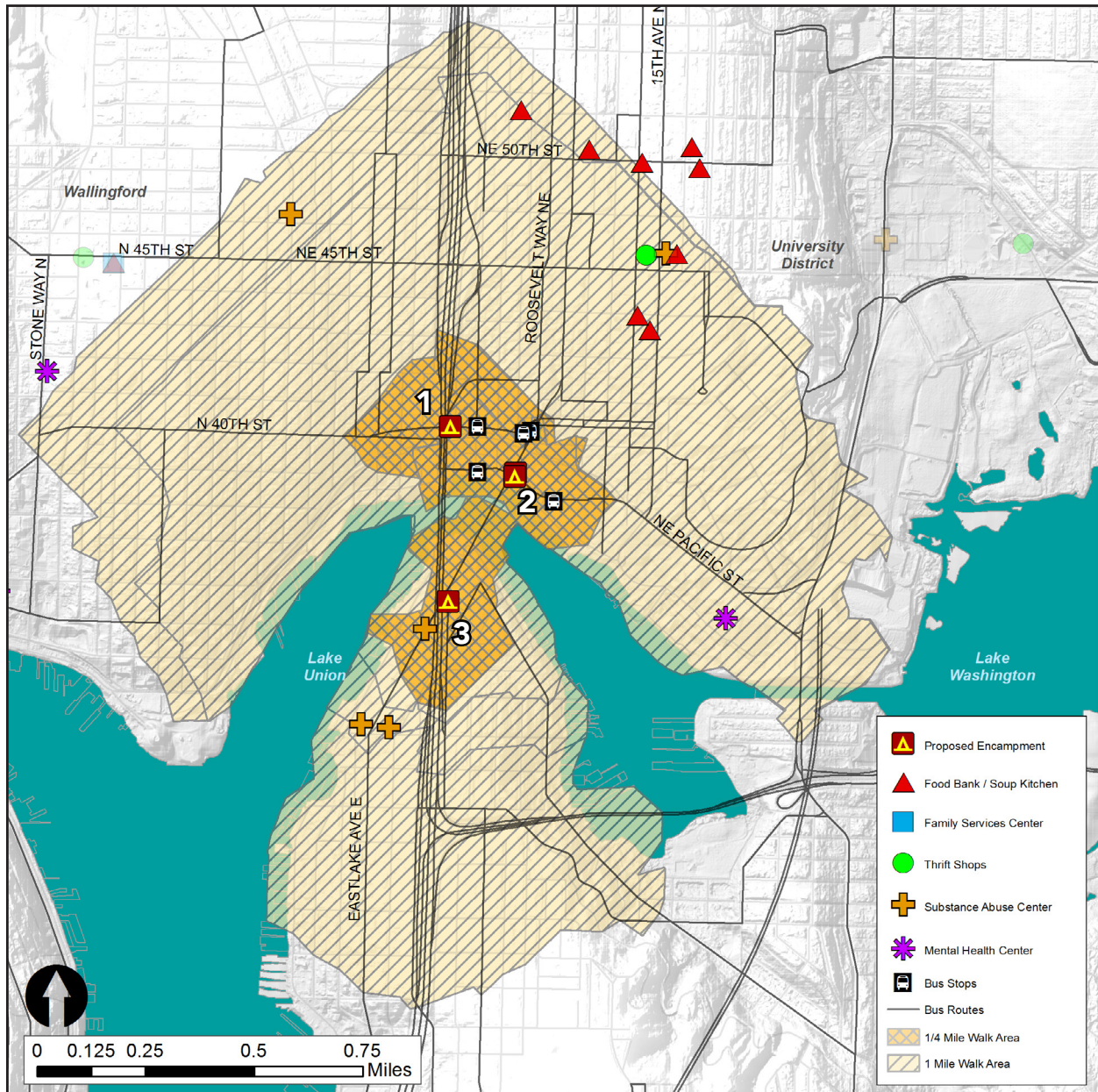

Figure 4.13: Portage Bay Region Sites Map

Square Footage: 9,000 - 42,000

Owner/Operator: Washington State Department of Transportation

Overpass Sufficiency Rating (2015): 67.7 - Ship Canal Bridge, 69.3 - University Bridge

Notable Nearby Landmarks: Lake Union, University of Washington, Montlake Cut

Three sites were identified in close proximity to one another near portage bay. The first is a storage lot below the northern approach of the University Bridge, the second is located below the northern portion of the I-5 Ship Canal Bridge near N 40th St and is primarily a vacant lot with a portion of WSDOT storage along the northern edge, and the third site exists below the southern portion of the Ship Canal Bridge within a privately managed parking lot that serves the George Pocock Rowing center and other nearby institutions. Each type of service center except for a family services center is located within the area's one mile walkshed, mainly near the University District.

Current Use:	Site 1: Empty Lot (Score: 100)
	Site 2: Storage (Score: 50)
	Site 3: Underutilized Parking Lot (Score: 50)
¼ Mile Walkshed	
o Bus Stops:	25
1 Mile Walkshed:	
o Mental Health Centers:	1
o Substance Abuse Centers:	4
o Family Services Centers:	0
o Food Banks/ Soup Kitchens:	6
o Thrift Shops:	1
Area Transit Score:	24
Area Service Centers Score:	9.09
Current Use Score -	Site 1: 33.33
	Site 2: 16.67
	Site 3: 16.67
Final Scores:	Site 1: 66.43
	Site 2: 49.76
	Site 3: 49.76

Magnolia Bridge

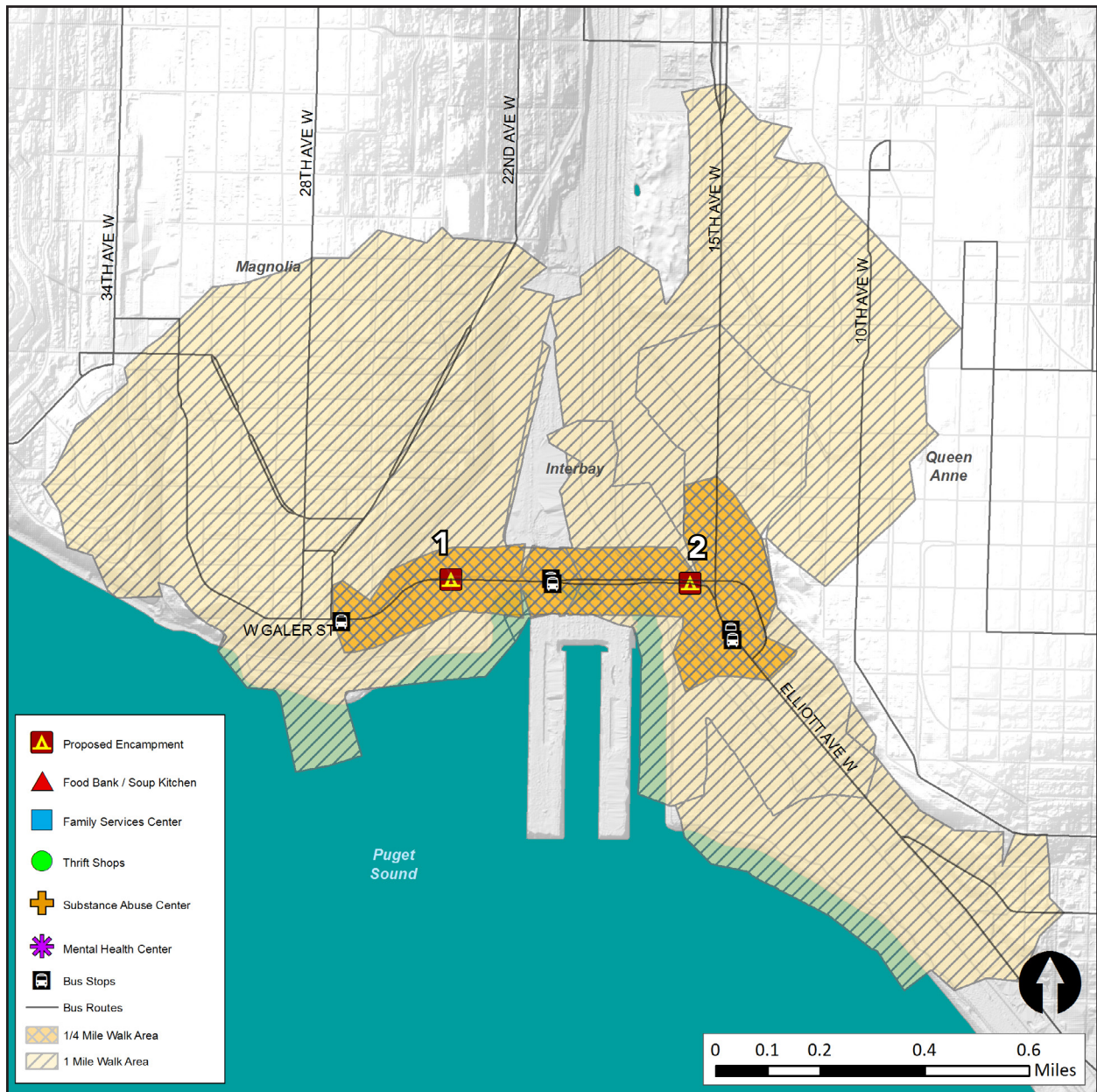

Figure 4.14: Magnolia Bridge Sites Map

Square Footage: Site 1 - 10,000, Site 2 - 20,000

Owner/Operator: Seattle Department of Transportation

Overpass Sufficiency Rating (2012): 17.7 for Site 1. 70.23 for Site 2.

Notable Nearby Landmarks: BNSF railyard, Interbay cruise ship terminals, Centennial Park

There are two potential sites located beneath the Magnolia bridge, one to the west beneath the 1930s viaduct, and the other to the east below the offramp to 15th Ave. Due to the fact that these sites are located in a largely industrial part of the city, there exist no nearby services, and any bus routes are located up on the bridge itself or on Elliott Ave. The sufficiency rating of the western section of the structure is also something to take note of, being one of the lowest on SDOT's sufficiency list. Calls for the bridge's replacement have been unending, largely due to the fact that the 2001 Nisqually earthquake damaged portions of the bridge significantly. Much of the area below the bridge is utilized as throughways for industrial activities like the Burlington Northern Santa Fe railyard and truck traffic between the working waterfront and warehouses to the north.

Current Use: Storage Lots/Shipping Area (Score: 0)		
¼ Mile Walkshed		
o Bus Stops:		6
1 Mile Walkshed:		
o Mental Health Centers:		0
o Substance Abuse Centers:		0
o Family Services Centers:		0
o Food Banks/ Soup Kitchens:		0
o Thrift Shops:		0
Area Transit Score:		16
Area Service Centers Score:		0
Current Use Score -	Site 1:	0
	Site 2:	0
Final Scores:	All Sites:	16

I-5 Colonnades

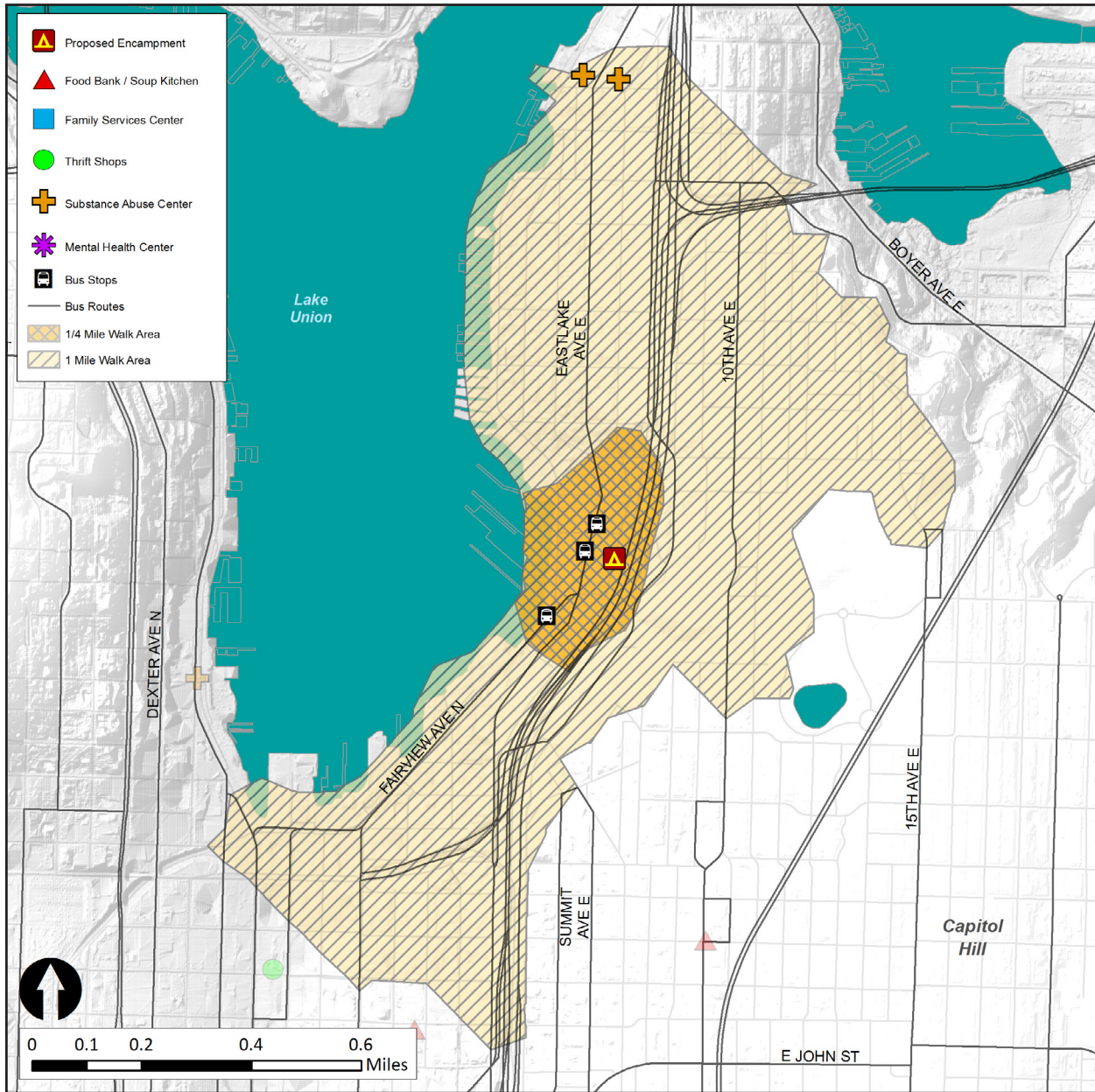

Figure 4.15: I-5 Colonnades Site Map

Square Footage: 50,000

Owner/Operator: Washington State Department of Transportation

Overpass Safety Rating (2013): 67.7

Nearby Landmarks: Eastlake, Montlake Cut, I-5 Colonnades Bike Park, MOHAI

This site is located directly beneath the Interstate 5 flyover between the Mercer Street onramps and the SR-520 interchange. Much of the covered space houses the groundbreaking I-5 Colonnades Park, a 7.5 acre mountain bike park that opened in 2005 as a partnership between the City of Seattle and the Evergreen Mountain Bike Alliance. The space examined is located just south of the park and currently contains an empty dirt lot. The site is served by three bus stops within the 1/4 mile walkshed. Unfortunately there are only two service centers of any kind nearby, Loveland Associates and Lake-Milam Recovery Center.

Current Use: Parking Lot / Empty Site (Score: 100)	
¼ Mile Walkshed	
o Bus Stops:	5
1 Mile Walkshed:	
o Mental Health Centers:	0
o Substance Abuse Centers:	2
o Family Services Centers:	0
o Food Banks/ Soup Kitchens:	0
o Thrift Shops:	0
Area Transit Score:	20
Area Service Centers Score:	1.02
Current Use Score:	33.33
Final Score:	54.36

I-5 Cherry Street

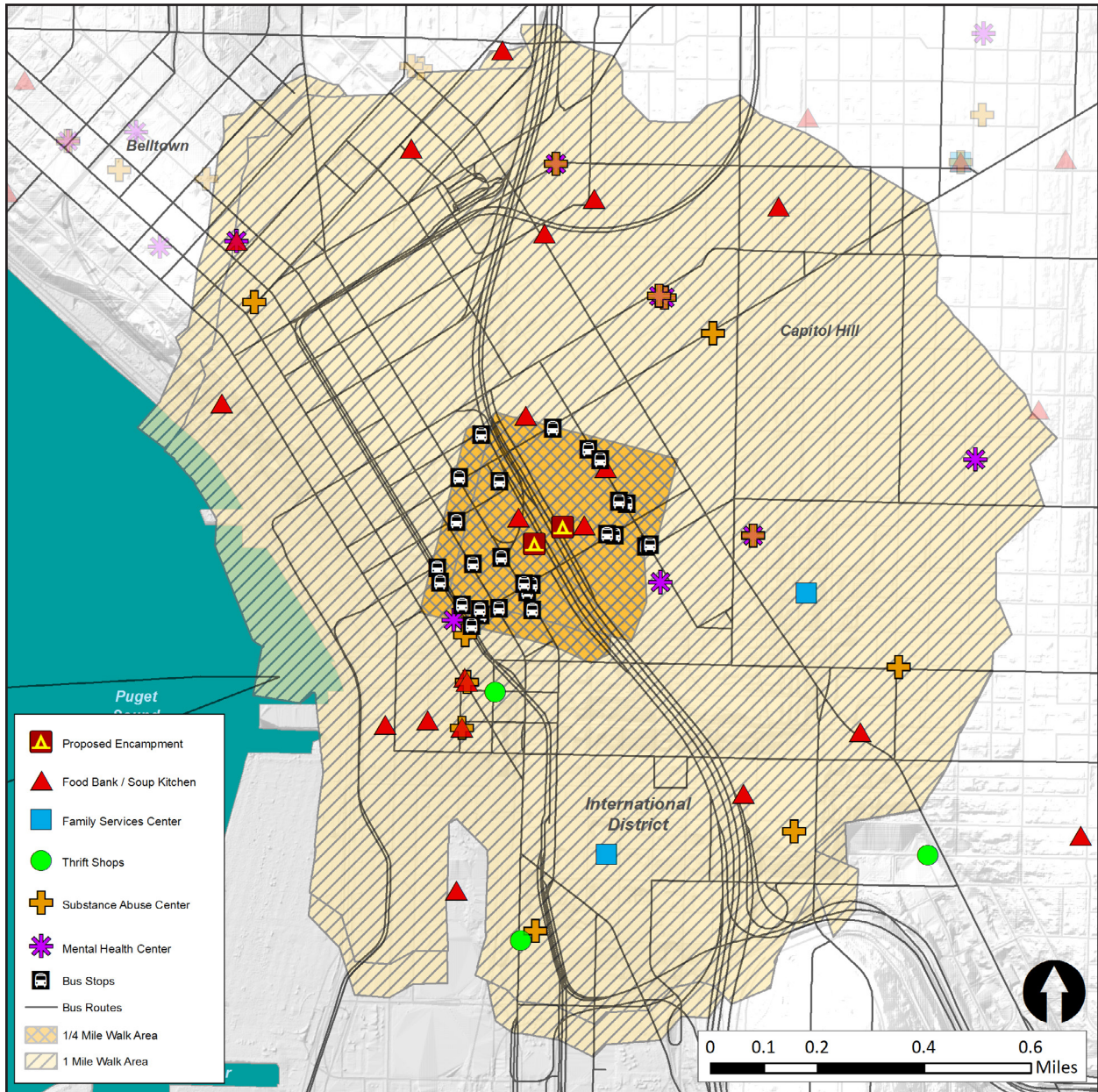

Figure 4.16: I-5 Cherry Street Sites Map

Square Footage: 36,000 to 78,000

Owner/Operator: Washington State Department of Transportation

Overpass Sufficiency Rating (2013): 65.5

Nearby Landmarks: Central Business District, Capitol Hill, Pike Place, Pioneer Square

The two sites identified below I-5 between Cherry St and James St are currently utilized as parking lots for area commuters. They are conveniently located near a plethora of transit options and service centers, many of which are within a quarter mile walkshed. Of all of the sites inventoried, the Cherry Street site offers the greatest opportunity for locating an encampment close to goods and services. The northern parking lot is even home to the Outdoor Meal Site, a partnership project between the City of Seattle and the nonprofit Only Serving Love that distributes meals to homeless individuals beneath the overpass seven days a week. The main potential hindrance to utilizing the site, however, would be the significant slope that exists from southwest to northeast.

Current Use: Heavily Utilized Parking Lots (Score: 0)	
¼ Mile Walkshed	
o Bus Stops:	26
1 Mile Walkshed:	
o Mental Health Centers:	8
o Substance Abuse Centers:	14
o Family Services Centers:	2
o Food Banks/ Soup Kitchens:	20
o Thrift Shops:	2
Area Transit Score:	33.33
Area Service Centers Score:	33.33
Current Use Score:	0
Final Score:	66.67

I-5 International District

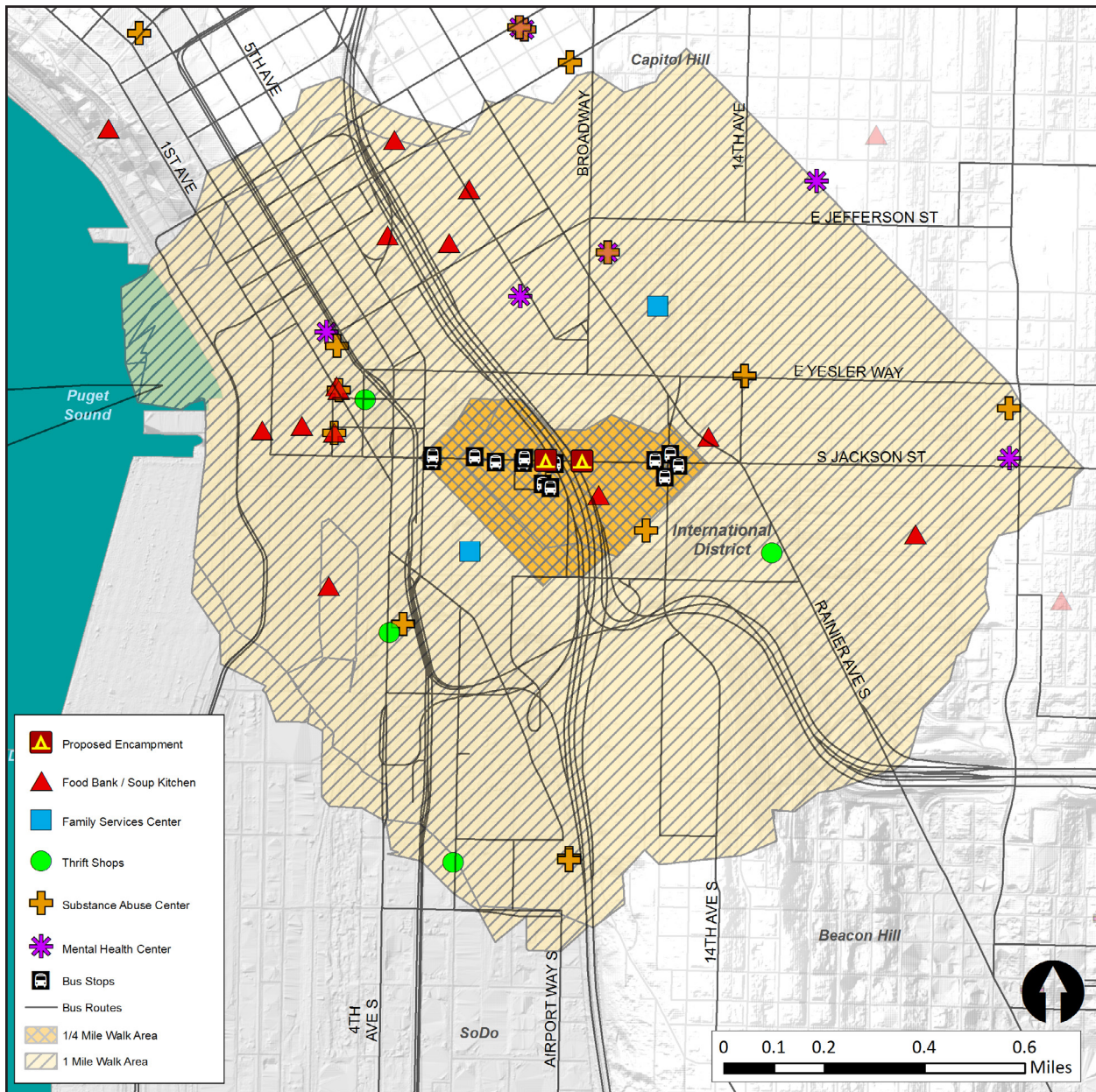

Figure 4.17: I-5 International District Sites Map

Square Footage: 30,000 each

Owner/Operator: Washington State Department of Transportation

Overpass Sufficiency Rating (2015): 84.1

Nearby Landmarks: International District, Pioneer Square, Yesler Terrace

The portion of I-5 crossing Jackson Street was built in 1965 and houses a heavily utilized parking lot. It is located near multiple bus stops, the majority of which are located along Jackson Street. One food bank, Asian Counseling and Referral Services, is located within the quarter mile walkshed. A plethora of service centers exist within the one mile walkshed, many of which are located in Pioneer Square to the west and First Hill to the north. The greatest abundance is that of food banks, with twelve in total. The parking lot itself was the focus of a public arts project completed in 2013 in which student volunteers painted the structural columns with artwork reflecting the cultural history of the International District.

Current Use: Utilized Parking Lot (Score: 0)	
¼ Mile Walkshed	
o Bus Stops:	14
1 Mile Walkshed:	
o Mental Health Centers:	4
o Substance Abuse Centers:	7
o Family Services Centers:	2
o Food Banks/ Soup Kitchens:	12
o Thrift Shops:	4
Area Transit Score:	33.33
Area Service Centers Score:	33.33
Current Use Score:	0
Final Score:	66.67

I-90 Interchange

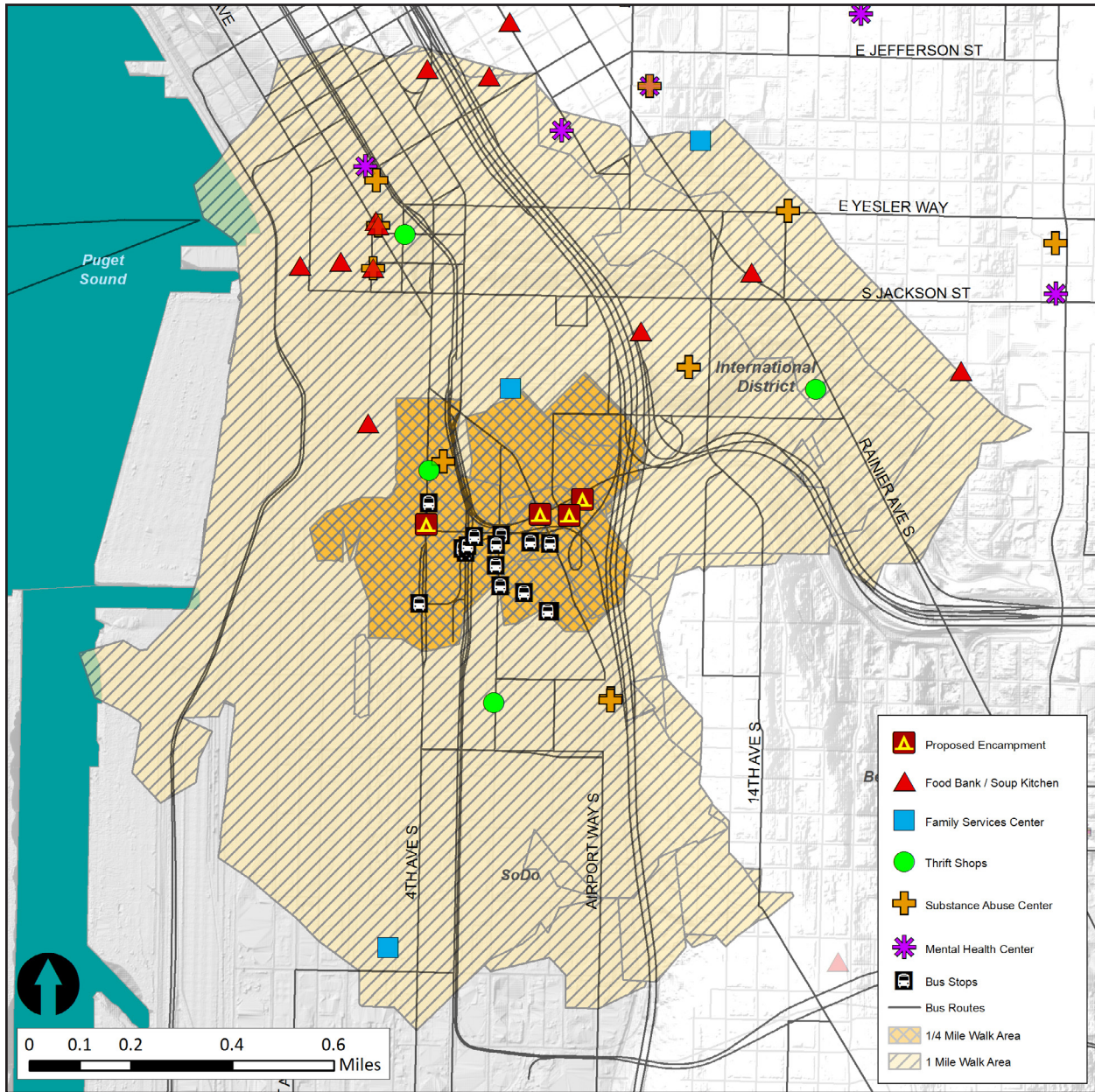

Figure 4.18: I-90 Interchange Sites Map

Square Footage: 8,900 - 35,500

Owner/Operator: Washington State Department of Transportation

Overpass Sufficiency Rating (2015): 99.8

Nearby Landmarks: SoDo, Stadium District, Pioneer Square, International District

The I-90 Interchange superstructure was built in 1991 to better connect I-5, I-90, and arterial streets surrounding the stadium district. Each of the identified lots is currently being used for storage by WSDOT crews. The area is conveniently located for bus and services access, with 15 stops, one substance abuse center and one thrift shop located less than one quarter mile from the western site. A link light rail station is also located directly between the four identified sites. A myriad of additional services exist within one mile of the area, 23 in total. This is largely due to the fact that the site is located adjacent to downtown, Pioneer Square and the International District, neighborhoods that host a great number of service centers. The immediate surrounding district itself is largely industrial.

Current Uses: Materials Storage (Scores: 50)	
¼ Mile Walkshed	
o Bus Stops:	15
1 Mile Walkshed:	
o Mental Health Centers:	2
o Substance Abuse Centers:	4
o Family Services Centers:	3
o Food Banks/ Soup Kitchens:	11
o Thrift Shops:	3
Area Transit Score:	32.67
Area Service Centers Score:	16.15
Current Use Score - All Sites:	16.67
Final Scores:	65.49

Spokane Street Viaduct

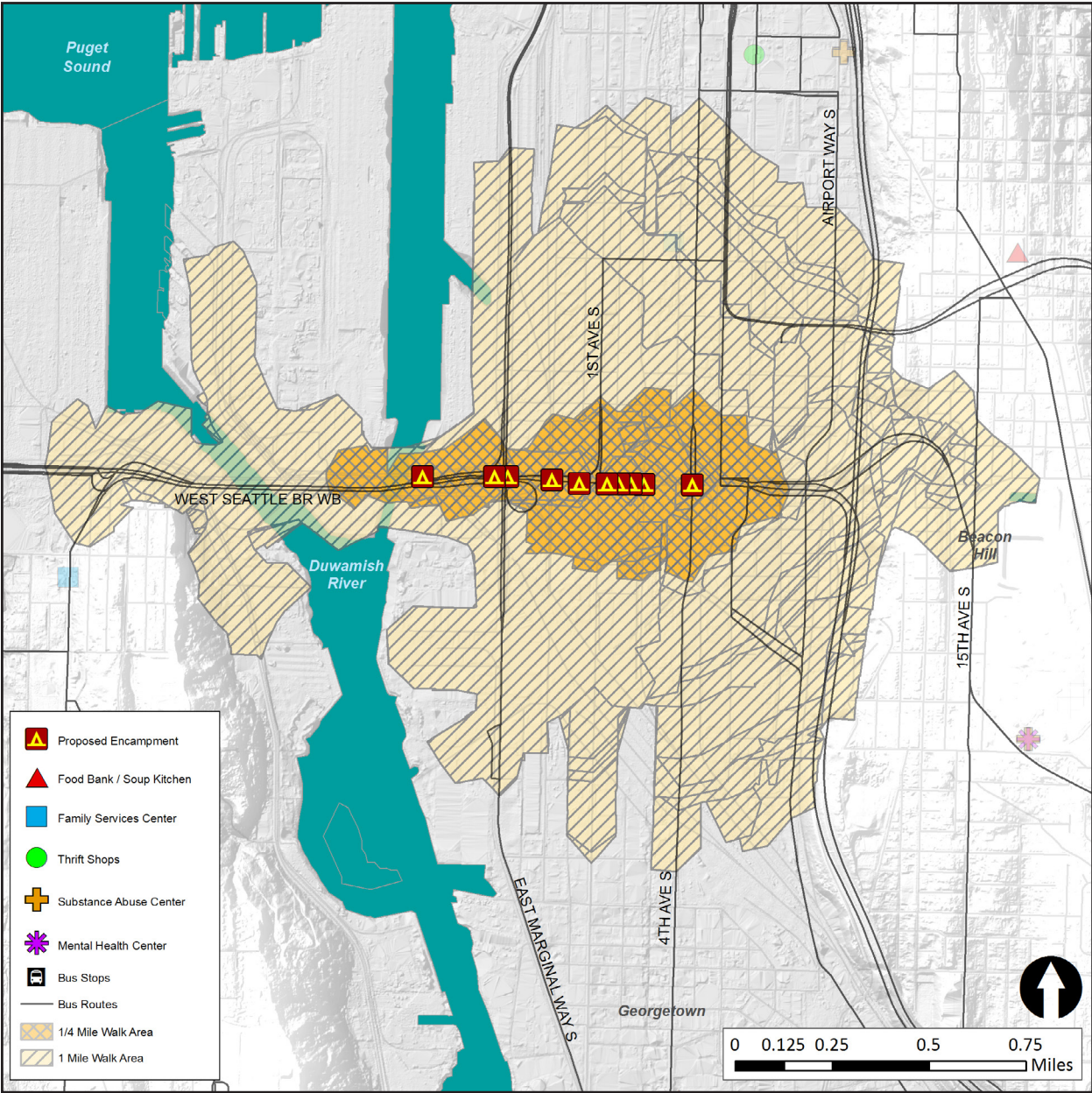

Figure 4.19: Spokane Street Viaduct Map

Square Footage: 5,600 to 39,000

Owner/Operator: Seattle Department of Transportation

Overpass Sufficiency Rating (2012): 50.45

Notable Nearby Landmarks/Districts: Duwamish River, SoDo, Beacon Hill, West Seattle

The nearly mile-long Spokane Viaduct presents a large amount of covered space for potential conversion into homeless encampment sites. Most of the area below is used as free public parking and is likely never near capacity. Eight bus stops clustered mainly around 4th Ave and the SoDo Busway provide easy access to downtown Seattle. Unfortunately the area is located in a largely unpopulated industrial area of the city, providing no service centers of any kind within either the quarter or one mile walksheds. For this reason alone, the Spokane Viaduct should not be considered for hosting encampments before other all alternative options have been exhausted.

Current Use: Underutilized Parking Lots (Score: 50)	
¼ Mile Walkshed	
o Bus Stops:	8
1 Mile Walkshed:	
o Mental Health Centers:	0
o Substance Abuse Centers:	0
o Family Services Centers:	0
o Food Banks/ Soup Kitchens:	0
o Thrift Shops:	0
Area Transit Score:	21.00
Area Service Centers Score:	0
Current Use Score - All Sites:	16.67
Final Scores:	37.67

Fauntleroy Expressway

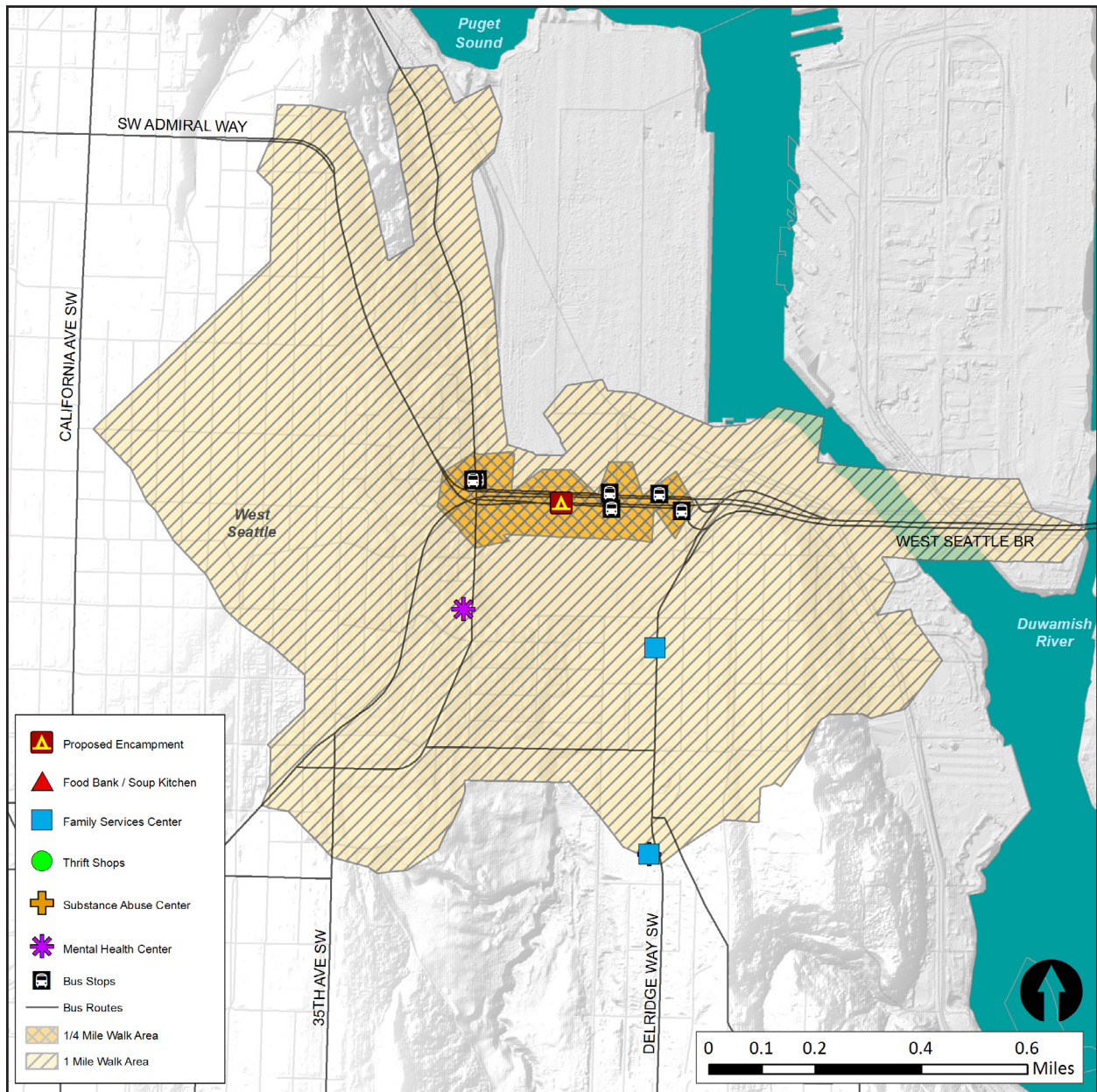

Figure 4.20: Fauntleroy Expressway Map

Square Footage: 6,700

Owner/Operator: Seattle Department of Transportation

Overpass Safety Rating (2012): 31.86. Improved in late 2012 following inspection.

Notable Nearby Landmarks/Districts: SoDo, Youngstown Community Arts Center, Alki Beach

The Fauntleroy Expressway connects Fauntleroy Way to the Spokane Viaduct and is located in West Seattle near the Duwamish River. The site itself is a Park and Ride lot managed by the city, likely used by workers of nearby industry. While it is well-served by transit, much of which travels between downtown much of West Seattle, it is lacking in service centers. Two family services centers are within walking distance: Southwest Youth and Family Services and a branch of the Department of Social and Health Services' Division of Children and Family Services, as well as one mental center: Transitional Resources. There exist no other service centers within the area.

Current Use: Park and Ride Lot (Score: 0)	
¼ Mile Walkshed	
o Bus Stops:	6
1 Mile Walkshed:	
o Mental Health Centers:	2
o Substance Abuse Centers:	0
o Family Services Centers:	1
o Food Banks/ Soup Kitchens:	0
o Thrift Shops:	0
Area Transit Score:	17.67
Area Service Centers Score:	1.31
Current Use Score:	0
Final Score:	18.98

Results

Following the GIS site analysis, final scores were ranked for each category in order from highest to lowest:



Transit Score

1.	I-5 Cherry Street	33.33
	International District	33.33
3.	I90 Interchange	32.67
4.	Portage Bay 1	24.00
	Portage Bay 2	24.00
	Portage Bay 3	24.00
7.	Spokane Street	21.00
8.	Fremont Bridge	20.33
9.	I5 Colonnade	20.00
10.	Green Lake 2	19.33
	Green Lake 1	19.33
12.	Ballard Bridge North	18.33
	Ballard Bridge South	18.33
14.	Fauntleroy Expressway	17.67
15.	Magnolia Bridge	16.00

Service Centers Score

1.	I-5 Cherry Street	33.33
2.	International District	19.69
3.	I90 Interchange	16.15
4.	Portage Bay 1	9.09
	Portage Bay 2	9.09
	Portage Bay 3	9.09
7.	Green Lake 2	6.32
	Green Lake 1	6.32
9.	Ballard Bridge North	2.62
	Ballard Bridge South	2.62
11.	Fremont Bridge	1.60
12.	Fauntleroy Expressway	1.31
13.	I5 Colonnade	1.02
14.	Spokane Street	0.00
15.	Magnolia Bridge	0.00

Current Use Score

1.	 <ul style="list-style-type: none"> Portage Bay 1 Green Lake 2 I5 Colonnade 	33.33 33.33 33.33
4.	 <ul style="list-style-type: none"> I90 Interchange Portage Bay 2 Portage Bay 3 Ballard Bridge North Spokane Street 	16.67 16.67 16.67 16.67 16.67
9.	 <ul style="list-style-type: none"> I-5 Cherry Street International District Green Lake 1 Ballard Bridge South Fremont Bridge Fauntleroy Expressway Magnolia Bridge 	0.00 0.00 0.00 0.00 0.00 0.00 0.00

Final Score

1.	I-5 Cherry Street	66.67
2.	Portage Bay. Site 1	66.43
3.	I90 Interchange	65.49
4.	Green Lake, Site 2	58.99
5.	I5 Colonnade	54.36
6.	International District	53.03
7.	Portage Bay, Site 2	49.76
8.	Portage Bay, Site 3	49.76
9.	Spokane Street	37.67
10.	Ballard Bridge North	37.62
11.	Green Lake, Site 1	25.66
12.	Fremont Bridge	21.93
13.	Ballard Bridge South	20.95
14.	Fauntleroy Expressway	18.98
15.	Magnolia Bridge	16.00

Looking at the results, it can be seen that the lowest performing sites were Magnolia Bridge and the Fauntleroy Expressway, receiving scores of 16 and 18.98, respectively. Both sites were located near few service centers and contained existing uses that are difficult to relocate. The Cherry Street region received the highest marks, with an overall score of 66.67. The sites here received high marks for both the Transit Score and the Service Centers Score, due largely to the location's close proximity to the Central Business District and its offerings. Unfortunately Cherry Street also received the lowest score possible for Current Use due to the site being used as a parking lot for area commuters. This reflects the fact that there is not necessarily a perfect liminal space in which to locate a homeless encampment. While a site may score high in one category, it often receives lower marks in another. This may be due to the fact that sites with greater transit access or in closer proximity to services are located in denser urban areas, making these spaces more valuable and thus less likely to remain underutilized.

Ultimately two sites were chosen for field visits based upon the Overall Scores: I-5 Cherry Street and Portage Bay Site 1. For the third site, I chose to visit and examine the Ballard Bridge North site in place of the Interstate 90 Interchange, the third highest scoring site overall. I chose to do so in order to provide a site analysis of a liminal space that was not located under or near a major highway. The I-90 site shares characteristics similar to that of Cherry Street and Portage Bay Site 1 in that it is located beneath freeway infrastructure and contains either parking lots or storage. Noise readings pulled from the area were similar to the preceding sites as well. The Ballard Bridge, however, is a slower speed, four-lane bascule bridge built in the 1930s, offering a significantly different structural form for examination in comparison to larger, modern highway flyovers. The Ballard Bridge North site was the highest scoring non-highway site, ranking tenth overall.

Chapter 5

Site Visits and Conclusion



Figure 5.1: I-5 Colonnade Park. Source: Max Baker



Figure 5.2: Recording noise levels. Source: Max Baker

Site Visits

The goal of the field visits was to identify any obvious hindrances that would need to be addressed when siting a homeless encampment. This included identifying any issues surrounding noise, access, and topography.

Noise

Noise is one of the larger concerns to be addressed when siting residences near roads and highways. At least one site identified near the I-5/I-90 interchange was disregarded in the City's final site selection process due to the level of noise in the area. In determining a covered space's potential for the siting of a homeless encampment, it is essential that any issues extending from prolonged noise exposure be remediated.

Noise levels are measured in decibels, with an approximate range of 0 to 120 for the human ear. While the decibel scale is linear, the intensity measure itself is exponential. This means that a noise recorded at 20 db is 100 times more powerful than that of one at 10 db, and a noise at 30 db is in turn 100 times more powerful than a noise recorded at 20 db. According to the U.S. Department of Health and Human Services, the recommended exposure limit for occupational noise exposure is 85 decibels (CDC). Once noise levels surpass 85 db, the power curve begins to increase significantly, making each additional decibel significantly more powerful than the last. Exposures at or above the 85 db threshold are thus considered hazardous.

For my site visits, I used the 85 decibel threshold as the level at which a site would not be considered for encampment siting. To determine whether or not a site qualified, I utilized a smartphone decibel meter app to capture noise

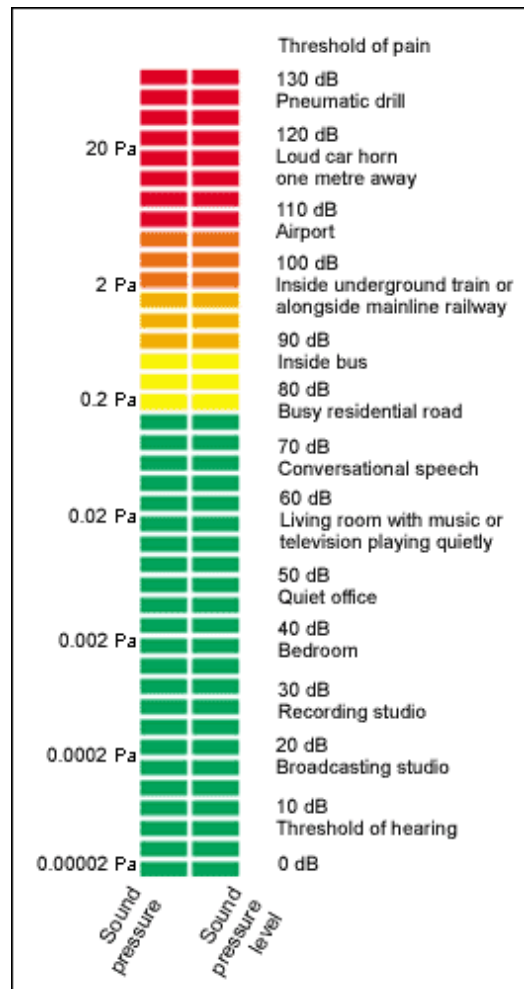

Figure 5.3: Decibel Chart. Source: OSHA

levels. These readings were captured twice at each site between the hours of 5 pm and 7 pm, during the weekday evening rush hour. Noise levels are usually expected to be greatest along roadways during this time, making it an appropriate period for capturing peak noise levels.

If noise levels were recorded at or below the 85 db threshold, shelter recommendations were developed based on the following scale: between 0 to 50 decibels a site would be acceptable for locating tents, at 35-70 decibels it is advised to consider the installation of tiny homes, and above 60 db it is recommended that more robust structures with heavier noise insulation be utilized. By using structures with greater insulation, any negative effects of prolonged noise exposure, especially at night, should be avoided. The sound reduction intensity of structures utilizing stud and gypsum board construction (like that of the tiny homes constructed by the Low Income Housing Institute) is estimated to be 36 db, meaning that a noise reduction of 36 decibels should be experienced within (HUD A-10). Increased insulation can bring additional noise reductions, potentially up to 63 decibels for wooden stud construction.

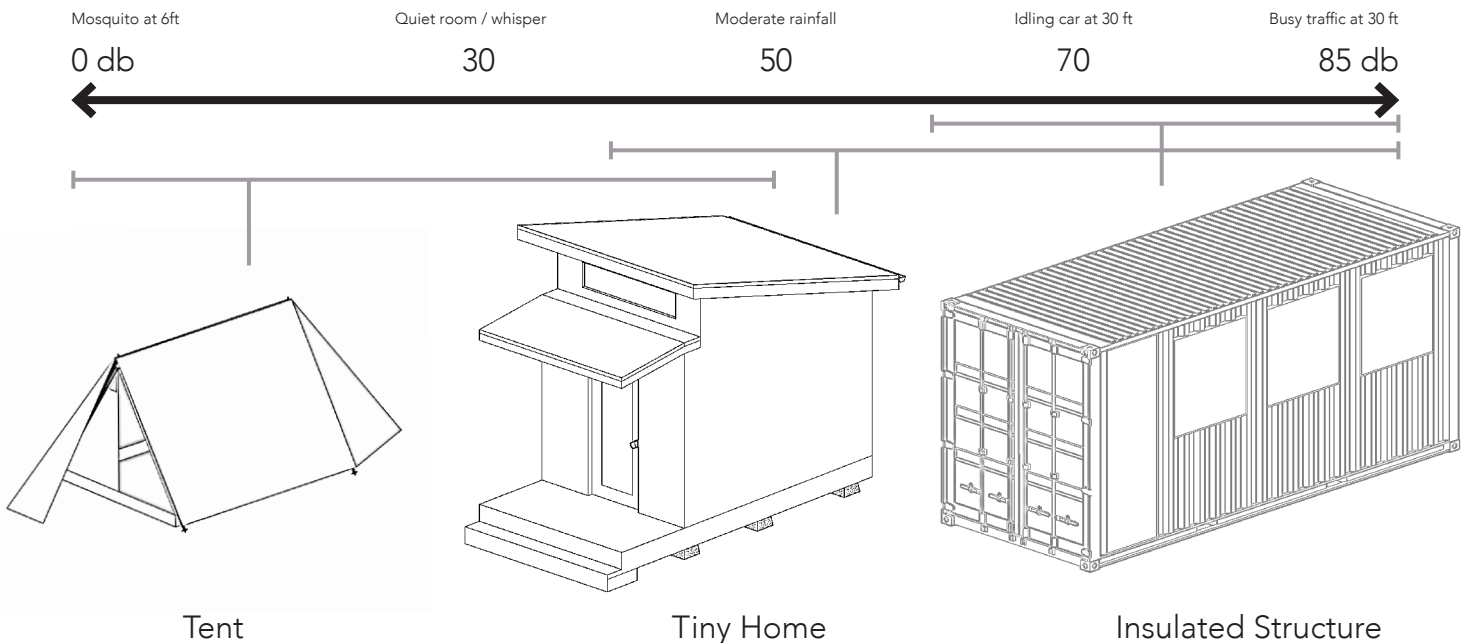

Figure 5.4: Recommended encampment structures based on decibel levels

Access

The City of Seattle’s requirements for access into a site are minimal, stating only that an encampment must comply with the health and safety requirements put forth in Seattle Municipal Code Section 23.42.054.B: “Access to garbage collection, suitable

location for providing food and bathroom services, and potential to provide parking for vehicles used as shelter or for workers who might assist encampment residents.” Ordinance 124747 details parking requirements for residents and workers: “1 space for every vehicle used as shelter; plus 1 space for each 2 staff members on-site at peak staffing times”. In making sure that adequate parking existed for a site, I decided that a minimum of two spaces must be located adjacent to or within an encampment. An easement must also be dedicated for waste management vehicles and highway crews to gain access into the area if need be.

Topography

Any issues with topography were noted during the site visits, and an estimate of the average grade was gathered using altimeter readings between the highest and lowest points. If sites were found to contain more varied topography, the use of semi-permanent structures like tiny homes were considered. This is due to fact that structures require the creation of a level foundation, an element that could more easily be fashioned to accommodate a slope than a simple tent platform. Sites with a inclination estimated to be greater than 8.33% should also not be considered for accommodating senior citizens or disabled residents, the American Disability Act’s upper threshold for sidewalk grades (DOJ).

Potential Future Considerations

While it was my intention to identify any major issues that may inhibit successful use of a site, I was unable to capture data regarding all potential site concerns. A major consideration that should be made moving forward is that of air pollution within a potential site location. It would be counter-productive to improve the lives of the city’s homeless by hosting them within encampments that expose them to potentially dangerous pollutants. However, a study by the Texas Transportation Institute found that carbon dioxide levels were lower for sensor sites adjacent to elevated freeways than for those next to at-grade or depressed roadways. This was thought to be due to the “possibilities (that elevated freeways) offer for increased turbulent dispersion of pollutants” (Nikolaou 55). This introduces the possibility that the air quality of encampments located beneath elevated structures is in fact better than that found within sites located directly adjacent to roadways, as each of the city’s encampments currently are. Regardless, pollution analyses may need to be completed to assuage any concerns around exposure levels within this study’s proposed sites.



Figure 5.5: Cherry Street Parking Lot Aerial. Source: Google



Figure 5.6: Cherry Street Parking Lot: Source. Max Baker

I-5 Cherry Street

Square Footage: 36,000 to 78,000

Owner/Operator: Washington State Department of Transportation

Overpass Sufficiency Rating (2013): 65.5

Nearby Landmarks: Central Business District, Capitol Hill, Pike Place, Pioneer Square

The Interstate-5 Cherry Street site scored highest in every category except for Current Use, bringing in a final score of 66.67/100. It is located less than one mile from 46 different service centers, less than one quarter mile from 26 bus stops, and received a perfect Transit Score of 100. The northern edge of the site also contains Only Serving Love's Outdoor Meal Site, a soup kitchen founded by singer Beverly Graham in 1989.

The site itself is composed of two parking sites, one on the northwestern side of Cherry Street and one on the southeastern side. These lots are owned by the Washington State Department of Transportation, and are managed by Republic Parking incorporated. A freeway entrance to the northbound lanes of Interstate 5 is located at the northeastern edge coming off of Cherry Street, making it a heavily utilized traffic area, especially during the rush hours. A total of six separate flyovers pass over the site: two on-ramps/off-ramps, two dedicated traffic lane overpasses, and two express-lane flyovers.

Noise

Noise levels at the I-5 Cherry Street site were the highest of any recorded. The average recorded decibel level between the two site visits was 83.2, with a range between 79 and 87. Such a noise level makes it imperative that the site utilize some form of heavily insulated structures to house residents, for it is much too loud for tents to even be considered. Fortunately, it falls just below the critical threshold of 85 db, making it a still viable site for hosting an encampment.

Topography

The topography of the site is perhaps the biggest challenge for siting an encampment, for the land slopes significantly heading northeast between 6th and 7th avenues. An average grade of 9% was calculated, with the site rising roughly 30 feet over a 300-

foot distance. This makes the area particularly challenging to establish level platforms within, making it suitable only for the placement of semi-permanent structures whose foundation can be more easily shaped to accommodate the changing geography.

Access

Access into the site is very easy, with multiple entry points provided thanks to the parking lot. By removing and/or rearranging a portion of either parking lot, there should be more than enough room to bring in support vehicles and provide overnight storage.

Current Use

The parking lots at I-5 Cherry Street were near capacity during both site visits, raising concern about the potential difficulty of removing parking spaces to install encampment structures. However, a quick Google Maps search produced ten parking lots or garages within a two block radius of the site which could provide alternative options to users. Utilization data on these lots was unfortunately not readily available. It should also be noted that the Outdoor Meal Site occupies former parking spaces, making it reasonable to believe that such a project could succeed there.

Design Intervention

The Cherry Street lot is paved for parking and thus fully improved, requiring little work to prep the site for an encampment. Given that each parking space is roughly 160 square feet and that LIHI tiny homes require only 96 square feet, individual parking spaces should easily accommodate one structure, making it easy to subdivide the site. Driving lanes could in turn be preserved as walkways.

Recommended Housing Types

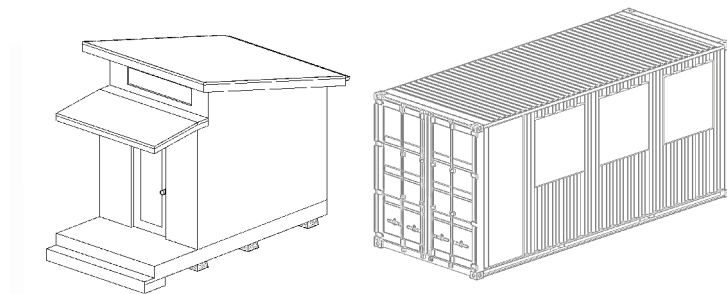



Before



After

Figure 5.7: Cherry Street Parking Lot Rendering: Source: Max Baker

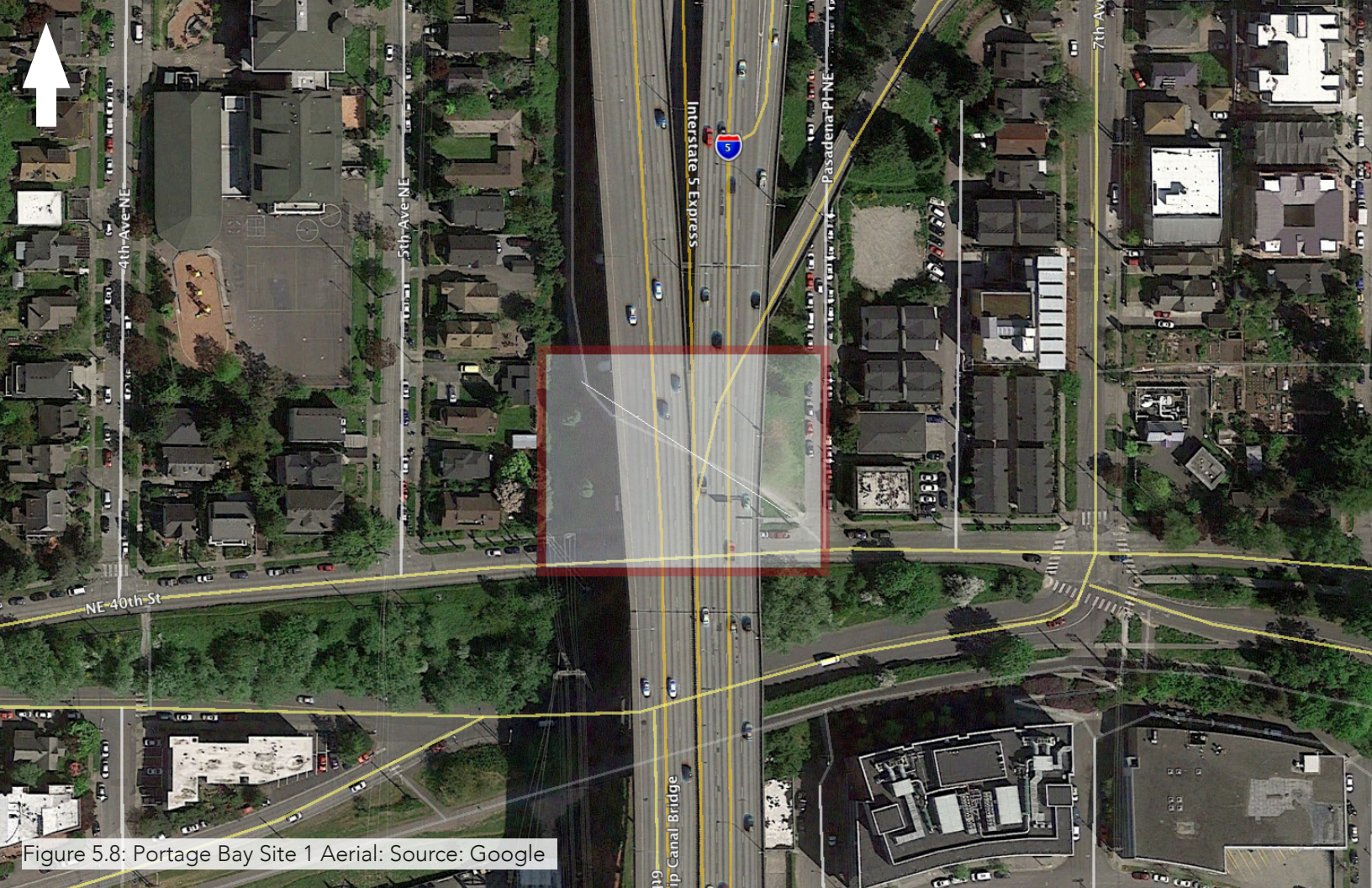

Figure 5.8: Portage Bay Site 1 Aerial: Source: Google



Figure 5.9: Portage Bay Site 1. Source: Max Baker

Portage Bay Site 1

Square Footage: 20,000

Owner/Operator: Washington State Department of Transportation

Overpass Sufficiency Rating (2015): 67.7 - Ship Canal Bridge

Notable Nearby Landmarks: Lake Union, University of Washington, Montlake Cut

Portage Bay Site 1 performed very well overall, coming in just behind I-5 Cherry Street with a final score of 66.43. The site was one of only three that contained completely unutilized land within, providing it with a perfect Current Use score. 12 service centers exist within a one-mile walkshed, and nearby bus access helps to give the site a relatively high Transit Score of 73.

The flyover itself is part of the northern approach to the Ship Canal Bridge, which was constructed in 1962. The entirety of the site is controlled by the Washington State Department of Transportation, which uses a small area near the northern structural supports for storage. Otherwise, the land has remained in a vacant state since the construction of the bridge. An informal user trail passes through the site, connecting NE 40th St. to NE 42nd St.

Noise

Noise levels at Portage Bay Site 1 were significantly lower than those recorded at Cherry Street. An average decibel level of 63.5 was captured, with a range between 53.6 db and 70.9 db. This makes the site appropriate for locating tiny homes and/or more insulated structures, but is too loud for extended use of tents.

Topography

The topography of the site is consistent, with an average measured grade of 10% moving from the low point at the southeast corner of the site to the high point at the northwest corner. This makes the utilization of platforms to accommodate the slope necessary. However, most of the land is simply exposed dirt, making it potentially possible to dig a flat platform in the ground itself if no utilities are located underneath.

Access

Access into the site is provided by NE 40th St. to the south and Pasadena Pl NE to the east. A dirt vehicle path currently exists leading from the intersection of these two streets into the site. This pathway would likely need to be moved to the eastern edge of the plot to accommodate WSDOT's crew vehicles. Parking for encampment support could be provided by the City along one of the two streets to prevent increased traffic at the intersection.

Current Use

Portage Bay Site 1's current unoccupied status makes it very attractive for locating a homeless encampment. Few covered liminal spaces in the city are mostly vacant, often being used for storage or parking. In this case, the site is largely empty and cleared of any debris or overgrowth, reducing the need for any anterior improvements. An adjacent grassy plot to the east also presents the possibility of installing a public resource like a community garden, which could help to support the encampment's residents.

Design Intervention

Portage Bay Site 1 is located on a largely dirt lot, making it important that any issues with water runoff or dust be remediated beforehand. Its south facing aspect makes it a prime site for installing vegetable planters that could work to feed encampment residents. The four large support pillars could be enhanced with public artwork, and the user trail identified through the site could be turned in a formal public walkway.

Recommended Housing Types

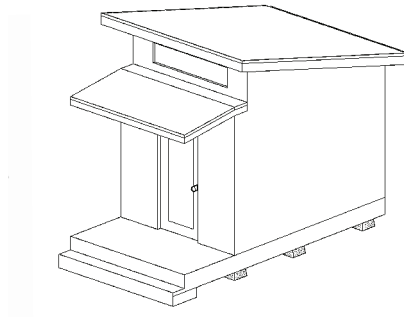



Before



After

Figure 5.10: Portage Bay Site 1 Rendering. Source: Max Baker

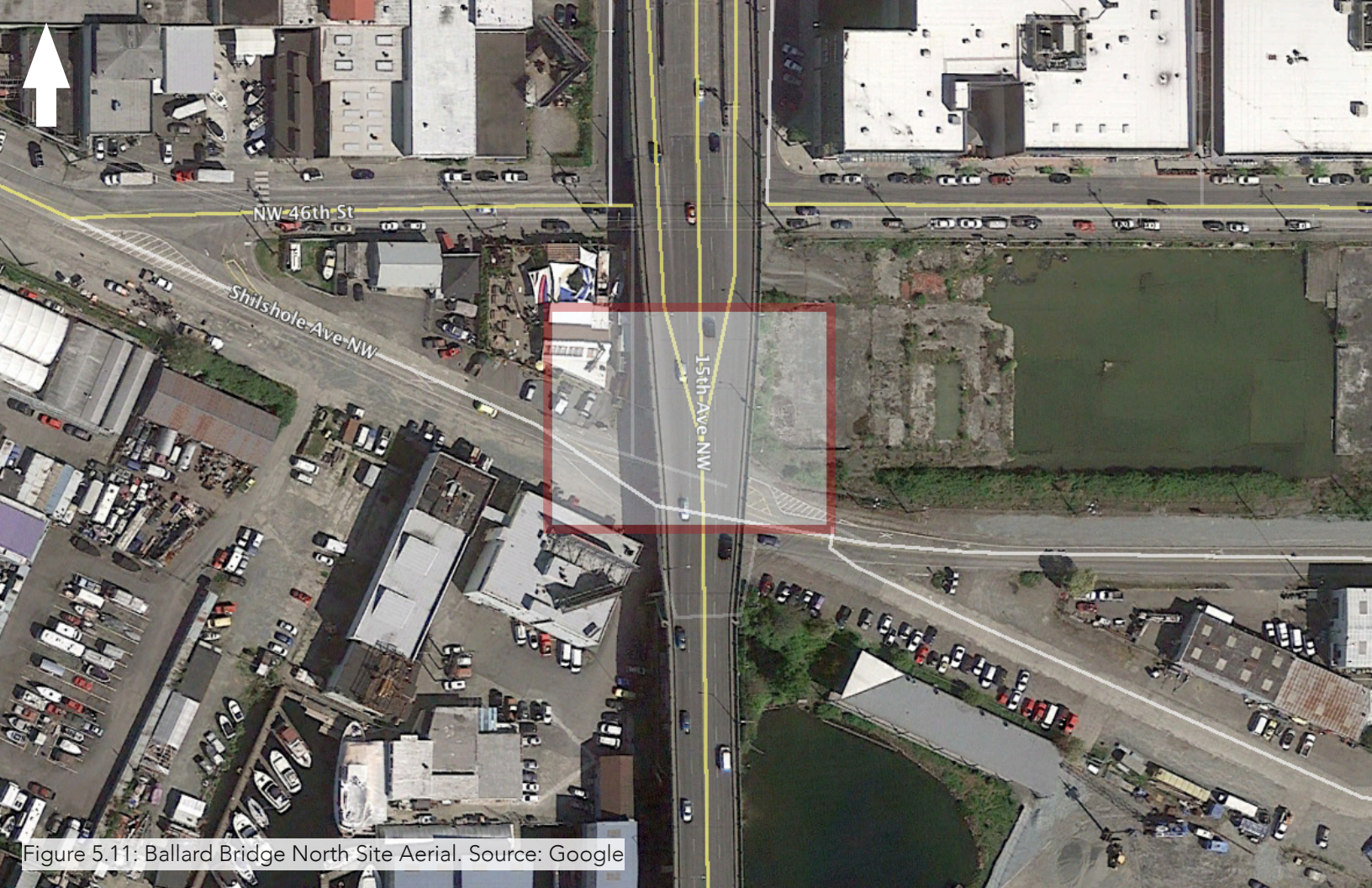

Figure 5.11: Ballard Bridge North Site Aerial. Source: Google



Figure 5.12: Ballard Bridge North Site. Source: Max Baker

Ballard Bridge North Site

Square Footage: Site 1 - 13,500, Site 2 - 8,700.

Owner/Operator: Seattle Department of Transportation

Overpass Safety Rating (2012): 48.45

Notable Nearby Landmarks: Fishermen's Terminal, Chittendem Locks, Ballard Commercial District

The Ballard Bridge was originally constructed in 1917, making it one of the oldest continuously operating bridges in Seattle. The original timber approaches were replaced in 1939 with concrete and steel superstructures, which were subsequently widened in the 1950s. The northern ramp crosses multiple rights of way as it descends to street level, creating a series of covered spaces below. The largest of these spaces is found in the area to the immediate north of Shilshole Avenue, approximately one block from the Ballard Blocks commercial development.

This site was previously used for the temporary siting of homeless individuals' RVs until a designated safe zone was established at the former Yankee Diner parking lot in early 2016. The majority of the space is now used as storage by the Seattle Department of Transportation.

Noise

In comparison to covered areas just to the north, the site is extremely quiet. An average decibel level of 56.6 was captured, with a range between 39.3 db and 72 db. This is roughly equivalent to the expected noise level within a quiet office. Such a level makes the space more than appropriate for siting all forms of encampment structures, from tents to more insulated structures.

Topography

The site is incredibly level and has recently been improved to accommodate the storage needs of SDOT. Little work would need to be done to transition the site for use by an encampment.

Access

46th Street to the north receives a slightly greater amount of road traffic due to its proximity to the Ballard Blocks development, but is still lower than that of Ballard Way NW and Leary Way NW to the north. Bus routes do not run near or through the site, using instead the wider arterials of 15th Avenue and Leary. The Burke Gilman bike path runs alongside 45th Street to the south, effectively turning Shilshole Avenue into a one-way single lane road that is used only by local traffic. Small alleys run alongside the eastern and western portions of the site and remain largely underutilized. Such spaces could potentially be used to park vehicles and/or provide storage.

Current Use

The site is incredibly level and has been recently restructured to accommodate the storage needs of SDOT. Small alleys run alongside the eastern and western portions of the site and remain largely underutilized. Such rights of way could potentially be used to park vehicles and/or provide storage for the encampment itself. Little additional work would need to be done to improve the area for constructing an encampment.

Design Intervention

Little basic work would need to be done to prep the area for siting tent platforms and camp structures. Fences could be installed to increase privacy and better separate the site from neighboring businesses. The site is relatively dark even during the daytime, making it vital that some form of overhead lighting be installed. A relatively large space between the bridge's pillars and The Burke Gilman trail could be used as a gathering area for residents and as the camp's main entrance.

Recommended Housing Types

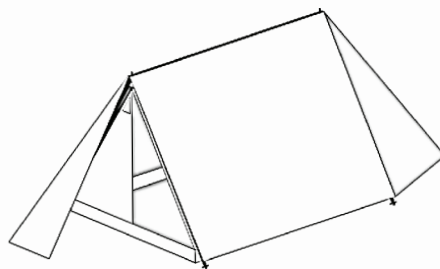



Before



After

Figure 5.13: Ballard Bridge Rendering. Source: Max Baker

Discussion and Conclusion

As Seattle's homelessness crisis continues to magnify, the importance of encampments will likely grow in tandem. However, land use pressures in a rapidly growing region like the Puget Sound may work to limit the future number of vacant parcels available for encampments, making it imperative that additional inventories be created. This is where the city's liminal spaces come into play, for they are areas in which few changes ever transpire. By looking to employ them for the siting of homeless encampments, these otherwise unutilized voids in the public realm may be reworked to provide much needed shelter for the disenfranchised.

In visiting the city's liminal spaces, I realized that these sites are usually devoid of human life, consigned to the storage of construction materials and commuter vehicles. This is unfortunate, as covered urban spaces easily lend themselves to the sheltering of Seattle's homeless. At least 300 individuals currently spend a winter's night beneath the city's roadways and infrastructure, a number that will likely only increase as the region's transitional housing and shelter systems remain overburdened (2016 Street Counts). Removing these spaces from access will only work to marginalize the homeless further, making life unimaginably more difficult for them.

The presence of liminal spaces is hard to ignore, taking form in dozens of locations across the city. Only through the most innovative approaches can these spaces be utilized, a practice that Seattle's homeless engage in each night as they look for a place to sleep. In learning from these individuals' examples, the formalization of encampments within underutilized covered spaces provides a new and obvious method of improving the urban realm while simultaneously addressing a basic need.

In working to evaluate the possibility of employing liminal spaces, I developed a new site selection process that builds upon the City of Seattle's current encampment siting process. While the City's approach is a good first effort, a number of shortcomings exist that need to be addressed. First, the 1/2-mile transit stop requirement does not adequately reflect common standards for transit access, especially when one considers that King County Metro buses will likely be the main form of transportation for residents. It also does not provide an apposite image of how well-served an area is by mass transit. Secondly, an absence of any form of rating system also makes it difficult to objectively determine which sites might be best suited to host an encampment

when compared to one another. My personal approach sets forth criteria that works to better address the needs of encampment residents while still acknowledging potential challenges within a site. Such a method would provide more objective results that would likely identify high-performance sites while satisfying the public's desire for accountability.

Through my method, a number of sites were identified that performed as well or better than current encampment locations, providing numerous sites that should more than satisfy the needs of the homeless. A total of 34 potential covered spaces were found to exist that meet the City's minimum site requirements. Of these at least three are completely vacant, requiring few improvements to accommodate an encampment. Six potential sites received higher scores than the City's lowest performing encampment in Interbay, which received an overall score of 50.

Site visits revealed that few modifications would need to be completed to improve liminal spaces to a state that would be appropriate for situating residents. Any issues with topography or access are often easy to overcome, and shelter structures can be adapted to a site based upon noise levels. Simple design interventions can work to re-imagine these areas not as dead spaces, but as vital sources of shelter and community.

There do exist a number of limitations given this project's limited time and resources, all of which must be addressed moving forward. While sound levels were recorded at what was expected to be peak intensities, more research into what conditions exist throughout the night should be explored before following through with an encampment installation. While research has found that consistent noise like that associated with steady traffic, i.e. white noise, is not incredibly bothersome, intermittent noises like aircraft takeoffs and/or banging can significantly disturb one's sleep (Stockman). For this reason, a relatively small range of noise levels should be observed throughout the night. Areas that contain serious spikes in noise levels, such as those near highway expansion joints, may need to be disregarded.

Potential issues near pollution sources, especially those that are airborne, should also be identified before siting an encampment. This may require taking pollution exposure readings beforehand, and/or developing mitigation strategies. However, the Texas Transportation Institute's study finding ground-level pollutant readings for elevated freeways to be considerably less than those recorded next to at-grade or depressed roadways is encouraging (Nikolaou). Additionally, the conversion of liminal spaces into formal encampments should only help to improve the health of some of the nearly

three hundred individuals that currently utilize such areas as refuge each night (2016 Street Counts).

Another potential issue is the diverse range of ownership patterns for Seattle's covered liminal spaces. While some areas are owned by the Seattle Department of Transportation and could be easily employed by the City, others are controlled by the Washington State Department of Transportation. Such areas may be subject to state control and in some cases federal regulation, especially if located beneath infrastructure that is part of the Interstate Highway System. Navigating the bureaucracy surrounding the use of such plots of land may present significant hurdles to stakeholders.

Moving forward, the City of Seattle and homeless encampment operators should explore any legal issues that may exist surrounding the use of covered spaces and work to adapt the land use code as needed. Maximum occupancy terms as currently required by the City's temporary use permits should be reconsidered, which would in turn reduce the amount of resources and energy that is need to relocate encampments every 1-2 years. An additional understanding of encampment residents' work and recreation patterns would also be constructive, adding supplementary dimensions that could be incorporated into the site scoring process.

In summation, the essential role of encampments should continue to be acknowledged by the City, and their deployment expanded. Only through the use of Seattle's covered liminal spaces will this likely be possible, making it imperative that such areas be considered in the future. By taking simple steps to introduce encampments into these areas, a safer and more equitable city will likely be shaped.

Works Cited

- "2016 Street Count Results." One Night Count. Seattle/King County Coalition on Homelessness. Web. 04 Feb. 2016. <http://www.homelessinfo.org/what_we_do/one_night_count/2016_results.php>.
- "A Tent City Primer." Greater Seattle Cares. Web. 05 February 2016.
- "About Us." Web. 10 Apr. 2016. <<http://www.ugm.org/site/PageServer?pagename=about>>.
- "American House Prices: Realty Check." The Economist. The Economist Newspaper, 03 Nov. 2015. Web. 04 Apr. 2016. <<http://www.economist.com/blogs/graphic-detail/2015/11/daily-chart-0>>.
- "Fred Database-S&P 500 Index". Research.stlouisfed.org. Retrieved 2013-08-17.
- "Fred Database-Unemployed". Research.stlouisfed.org. Retrieved 2013-08-17.
- "FY 2016 Appropriations: HUD Homeless Assistance Grants." National Alliance to End Homelessness, 3 Feb. 2015. Web. 04 Mar. 2016. <<http://www.endhomelessness.org/library/entry/fy-2015-appropriations-hud-homeless-assistance-grants>>.
- "FY 2016 Appropriations: HUD Homeless Assistance Grants." National Alliance to End Homelessness, 3 Feb. 2015. Web. 04 Mar. 2016. <<http://www.endhomelessness.org/library/entry/fy-2015-appropriations-hud-homeless-assistance-grants>>.
- "Hong Kong's 'New Homeless' Epidemic." The Chinese University of Hong Kong. Feb. 2015. Web. <<http://www.cuhk.edu.hk/english/features/professor-wong-hung.html>>.
- "HUD - Federal Housing Administration." HUD - Federal Housing Administration. US Dept. of Housing and Urban Development. Web. 04 Apr. 2016.
- "Kincaid v. City of Fresno." ACLU of Northern California. 21 May 2009. Web. 05 May 2016.
- "Off The Beat: What Laws Did Hawaii Rep. Tom Brower Break?" Civil Beat News. 22 Nov. 2013. Web. 05 May 2016. <<http://www.civilbeat.com/2013/11/20487-off-the-beat-what-laws-did-hawaii-rep-tom-brower-break/>>.
- "Populations on the Rise." Urban. National Geographic. Web. 11 Apr. 2016. <<http://environment.nationalgeographic.com/environment/habitats/urban-profile/>>.
- "Tent City 4." Wikipedia: The Free Encyclopedia. Wikimedia Foundation, Inc. 16 April 2016. Web. 2 May 2015.
- "The Cleveland Policy Plan Report," Norman Krumholz, Janice Cogger, John Linner,

in *Journal of the American Institute of Planners*, September, 1975.

- "The Dangers of Cold Weather - National Coalition for the Homeless." National Coalition for the Homeless. 07 Feb. 2014. Web. 20 Feb. 2016.
- "Tiny Houses Moving Forward!" Low Income Housing Institute. 25 Nov. 2015. Web. 12 Feb. 2016.
- "Unemployment Statistics during the Great Depression." Unemployment Statistics during the Great Depression. Online Highways LLC. Web. 22 Mar. 2016.
- A World At School. "Shopkeeper Who Teaches Indian Slum Children at His School under a Bridge | A World At School." India. 5 Aug. 2014. Web. 30 May 2016. <<http://www.aworldatschool.org/news/entry/School-under-bridge-for-slum-children-in-New-Delhi>>.
- Agans, Robert, Guangya Liu, Mary Jones, Clementina Verjan, Mark Silverbrush, and William Kalsbeek. "Public Attitudes Toward the Homeless." AAPOR (2011): 5935-946. Web.
- Alexander, Rachel. "Two Years In, Homeless Feel Targeted by Sit-lie Law." Spokesman.com. 13 Dec. 2015. Web.
- Andreou, Alex. "Defensive Architecture: Keeping Poverty Unseen and Deflecting Our Guilt." *The Guardian*. Guardian News and Media, 18 Feb. 2015. Web.
- Associated Press. "Income Gap Widens as Poor Lose Ground in Recession Recovery: Report." NBC News. 14 Jan. 2016. Web. 03 June 2016. <<http://www.nbcnews.com/feature/in-plain-sight/income-gap-widens-poor-lose-ground-recession-recovery-report-n496551>>.
- Balk, Gene. "Census: Seattle Saw Steepest Rent Hike among Major U.S. Cities." *The Seattle Times*. 18 Sept. 2014. Web. 03 June 2016.
- Baumohl, Jim., and National Coalition for the Homeless. *Homelessness in America*. Phoenix, Ariz.: Oryx, 1996. Print.
- Beckett, Katherine, and Herbert, Steven Kelly. *Banished : The New Social Control in Urban America*. Oxford ; New York: Oxford UP, 2010. Print. Studies in Crime and Public Policy.
- Beekman, Daniel. "Mayor, County Exec Declare 'state of Emergency' over Homelessness." *The Seattle Times*. 02 Nov. 2015. Web. 04 Feb. 2016.
- Beekman, Daniel. "Seattle-area Count Finds 'huge Spike' in Homelessness." *The Seattle Times*. 29 Jan. 2016. Web. 03 June 2016.
- Beekman, Daniel. "Stop Opening Tent Cities, Homelessness Expert Tells Seattle Leaders." *The Seattle Times*. 26 Feb. 2016. Web.
- Bodenmüller, Klaus Otto. *The Alaskan Way Viaduct*. Seattle]: [publisher Not Identified], 1981. Print.

- Bratt, Rachel, Stone, Michael, and Hartman, Chester, eds. *Right to Housing : Foundation for a New Social Agenda*. Philadelphia, PA, USA: Temple University Press, 2006. ProQuest ebrary. Web. 25 April 2016.
- Brayden, Joanne. "Nickelsville Security, Part 2: Who's in Charge, Anyway?" *West Seattle Blog*. 4 June 2011. Web. 1 Mar. 2016. <<http://westseattleblog.com/2011/06/nickelsville-security-part-2-whos-in-charge-anyway/>>.
- Broom, Jack. "New City-sponsored Homeless Camp Opens in Interbay." *The Seattle Times*. 19 Nov. 2015. Web. 30 May 2016.
- Byrne, Thomas, Ellen A. Munley, Jamison D. Fargo, Ann E. Montgomery, and Dennis P. Culhane. "New Perspectives on Community Level Determinants of Homelessness." *Journal of Urban Affairs* 35.5 (2013): 607-25. Web.
- Cauvin, Henri. "More Families Became Homeless in Recession." *The Washington Post*, 13 Jan. 2011. Web. 04 Apr. 2016.
- CDC/NIOSH. *Noise and Hearing Loss Prevention*. Cincinnati, OH: U.S. Department of Health and Human Services; 1998.
- Chicago, Illinois, § 8-4-015
- Chun, Yao. "Has the Land Value of Beijing Surpassed the Annual GDP of US? - People's Daily Online." *People's Daily Online*, 30 Aug. 2013. Web. 12 Apr. 2016.
- City of Seattle Office of Housing. *Alternatives for Homeless Services Response to Resolution #31292*. Rep. Seattle, 2011. Print.
- City of Seattle Office of Housing. *Seattle Homeless Needs Assessment 2009*. Rep. Seattle, October 2009. Print.
- City of Seattle. *Housing Seattle: A Roadmap to an Affordable and Livable City*. Rep. Seattle, Jul 13, 2015. Print.
- Cleary, Richard Louis. *Bridges*. 1st ed. New York : Washington, D.C.: Norton ; Library of Congress, 2007. Print. Norton/Library of Congress Visual Sourcebooks in Architecture, Design, and Engineering.
- Cox, Wendell. "The Evolving Urban Form: The Valley of Mexico." *Newgeography.com*. 2 Mar. 2011. Web. 11 May 2016. <<http://www.newgeography.com/content/002088-the-evolving-urban-form-the-valley-mexico>>.
- Demirel, Magic. "Seattle's "Hooverville": The Failure of Effective Unemployment Relief in Early 1930s Seattle." *Seattle's Hooverville*. 2009. Web. 10 Mar. 2016.
- DeNavas-Walt, Carmen, Bernadette D. Proctor, and Jessica C. Smith. "Income, Poverty, and Health Insurance Coverage in the United States: 2012."
- Dept. of Civil Engineering. "CIVL 1101 - Interesting Stuff." University of Memphis, 1997. Web. 15 May 2016. <http://www.ce.memphis.edu/1101/interesting_stuff/7wonders.html>.

- Design Trust for Public Space. *Under the Elevated: Reclaiming Space, Connecting Communities*. New York City: Design Trust for Public Space, 2015. Print.
- Dhumieres, Marie. "These 100 People Live Inside (Literally) an Urban Bridge - NBC News." NBC News, 1 Apr. 2014. Web. 11 May 2016. <<http://www.nbcnews.com/news/world/these-100-people-live-inside-literally-urban-bridge-n68731>>.
- Doron, Gil M. "The Dead Zone and the Architecture of Transgression." *City 4.2* (2000): 247-63. Web.
- Ellen, Ingrid Gould, and Samuel Dastrup. "Housing and the Great Recession." Policy Brief (2012).
- Erlacher, Gisela., Lička, Lilli, Lodermeier, Peter, and Cowper, Simon. *Himmel Aus Beton = Skies of Concrete* : Gisela Erlacher. Zürich: Park, 2015. Print.
- Federal Highway Administration. "Bridges & Structures." 2015. Web. <<http://www.fhwa.dot.gov/bridge/nbi/no10/deck15.cfm>>.
- Feit, Josh. "The Biggest Story of 2015." *The Biggest Story of the Year Was the Dramatic Increase in Homelessness | Seattle Met*. Seattle Met, 30 Dec. 2015. Web.
- Fleming, Daniel, Patrick Burns, and Michael Matsunaga. *Where We Sleep Costs When Homeless and Housed in Los Angeles*. Rep. Los Angeles, 2009. Print.
- Gallup Inc. *Homelessness in America Americans' Perceptions, Attitudes and Knowledge*. Rep. November 2007. Print.
- Greater Seattle Cares. *Greater Seattle Cares Financial Report January – December, 2010*. Rep. Web. <<http://greaterseattlecares.org/wp-content/uploads/rptGSC-Financial-2010.pdf>>.
- Green, Jason. "Palo Alto Passes Vehicle Dwelling Ban." *San Jose Mercury News*. 6 Aug. 2013. Web.
- Greenhouse, Linda. "Loitering Law Aimed at Gangs Is Struck Down by High Court." *The New York Times*. The New York Times, 11 June 1999. Web.
- Griffin, Anna. "Our Homeless Crisis." *OregonLive.com*. 17 Jan. 2015. Web. <<http://www.oregonlive.com/portland-homeless/>>.
- Groover, Heidi. "City Calls Nonprofit's Closure of 15 Homeless Shelters an Unnecessary "Advocacy Move." *The Stranger*. 31 Mar. 2016. Web. 30 May 2016.
- Hellegers, Desiree. *No Room of Her Own: Women's Stories of Homelessness, Life, Death, and Resistance*. New York: Palgrave Macmillan, 2011.
- Henry, Meghan, and M William Sermons. *Geography of Homelessness, Part 4: Examining Urban Homelessness*. Rep. National Coalition of Homelessness, March 2010. Print.
- Herz, Rick., Hagler, Tamar, and National Law Center on Homelessness & Poverty. *No Homeless People Allowed : A Report on Anti-homeless Laws, Litigation and*

Alternatives in 49 United States Cities. Washington, D.C.]: [National Law Center on Homelessness & Poverty], 1994. Print.

- Hoag, Christina. "Low-Income Housing Funds Are Drying Up All Over America." TakePart. 13 Jan. 2015. Web. 04 May 2016. <<http://www.takepart.com/article/2015/01/13/low-income-housing>>.
- Holley, Peter. "After 90-year-old Is Arrested, Florida Judge Halts Law That Restricts Feeding the Homeless." Washington Post. The Washington Post, 3 Dec. 2014. Web. 12 Mar. 2016.
- Huang, Josie. "LA Sued over Seizure of Homeless People's Belongings." Southern California Public Radio. 14 Mar. 2016. Web. 05 May 2016. <<http://www.scpr.org/news/2016/03/14/58542/la-sued-over-homeless-sweeps-law/>>.
- Human Services Department. Homelessness Investment Analysis. By City of Seattle Office of Housing. Seattle, March 2015. Print.
- Hunter, Julie, Paul Linden-Rintek, Sirine Shebya, and Samuel Halpert. Welcome Home: The Rise of Tent Cities in the United States. Rep. National Law Center on Homelessness and Poverty, March 2014. Print.
- Information Services Department. Hong Kong: The Facts. Rep. Hong Kong: Hong Kong Special Administrative Region Government, 2015. Print.
- Institute for Children, Poverty and Homelessness. Tracking Public Opinion on Family Homelessness. Rep. February 2011. Print.
- King County (Wash.). Transit Division. King County Metro Transit: Strategic Plan for Public Transportation. By King County Metro. Seattle, WA, 2013. Print.
- King, John (October 17, 2004). "15 SECONDS THAT CHANGED SAN FRANCISCO / The sweeping makeover that transformed the city began 15 years ago today with the Loma Prieta earthquake." San Francisco Chronicle.
- Kittelson & Associates, National Research Council . Transportation Research Board, United States. Federal Transit Administration, and Transit Development Corporation. Transit Capacity and Quality of Service Manual. 3rd ed. Washington, D.C.: Transportation Research Board, 2013. Print. Report (Transit Cooperative Research Program) ; 165.
- Knight, Heather. "San Francisco Looks to Seattle: Did Sidewalk Sitting Ban Help?" Seattlepi.com. 29 Mar. 2010. Web. <<http://www.seattlepi.com/local/article/San-Francisco-looks-to-Seattle-Did-sidewalk-888774.php>>.
- Ko, Vanessa. "In Cramped Hong Kong, a Home under the Bridge | ZDNet." ZDNet, 28 Feb. 2013. Web. 11 May 2016. <<http://www.zdnet.com/article/in-cramped-hong-kong-a-home-under-the-bridge/>>.
- Larsen, Jacob; El-Geneidy, Ahmed; Yasmin, Farhana. Canadian Journal of Urban

Research, suppl. *Canadian Planning and Policy* 19.1 (2010): 70-88.

- Law, Emily. "Survey Finds a 400% Increase in the Number of Homeless People Staying in 24-hour Fast-food Shops Overnight." City University of Hong Kong. 11 Jan. 2016. Web.
- Lawson, Roger and William Julius Wilson "Poverty, Social Rights, and the Quality of Citizenship", in McFate, Katherine, Roger Lawson, and William Julius Wilson(eds.) (1995) *Poverty Inequality and the Future of Social Policy*, Russell Sage Foundation, 693-714 <http://courses.washington.edu/gmforum/Readings/Lawson.pdf>
- Levintova, Hannah. "Is Giving Food to the Homeless Illegal in Your City Too?" Mother Jones. 13 Nov. 2014. Web.
- Libby, Brian. "Under the Freeway: AIA Announces Stitch II Ideas Competition Winners." Portland Architecture. 24 June 2015. Web. 11 May 2016. <<http://chatterbox.typepad.com/portlandarchitecture/2015/06/under-the-freeway-aia-announces-stitch-ii-ideas-competition-winners.html>>.
- Liu, Zhifeng, Chunyang He, Yuyu Zhou, and Jianguo Wu. "How Much of the World's Land Has Been Urbanized, Really? A Hierarchical Framework for Avoiding Confusion." *Landscape Ecology* 29.5 (2014): 763-71. Web.
- Matthews, Chris. "Why Should You Only Spend 30% of Your Income on Housing?" Fortune Magazine. 4 Aug. 2015. Web. 10 Mar. 2016.
- Minneapolis, Minn., Code of Ordinances § 244.60(a)(2013).
- Miroff, Nick. "In Mexico City, Planners Turn Vacant Space under Freeways into Places to Work, Dine, Play." The Washington Post, 29 May 2013. Web. 11 May 2016.
- Morse, Jack. "Sub-Par Pier 80 Homeless Shelter Costs More Per Bed Than An Airbnb Or Hotel Room." SFist. 11 Feb. 2016. Web. 30 Jan. 2016. <http://sfist.com/2016/02/11/pier_80_homeless_shelter_costs_1_mi.php>.
- Moyer, Justin. "Three Teens Arrested in Connection with Shooting at Seattle Homeless Camp 'the Jungle'." Washington Post. The Washington Post, 2 Feb. 2016. Web.
- National Alliance to End Homelessness. *The State of Homelessness in America 2014*. Issue brief. Washington D.C., 20. Print..
- National Alliance to End Homelessness. *The State of Homelessness in America 2015*. Issue brief. Washington D.C., 20. Print.
- National Coalition for the Homeless. *McKinney-Vento Act*. Publication. Washington D.C., June 2006. Web. <<http://www.nationalhomeless.org/publications/facts/McKinney.pdf>>.
- National Coalition for the Homeless. *Winter Homeless Services: Bringing Our Neighbors in from the Cold*. Issue brief. January 2010. Print.

- National Law Center on Homelessness & Poverty. No Safe Place: The Criminalization of Homelessness in U.S. Cities. Rep. Washington D.C., 2014. Print.
- Nikolaou, Michael. Traffic Air Pollution Effects of Elevated, Depressed, and At-grade Level Freeways in Texas. College Station, TX: Texas Transportation Institute, Texas A & M U System, 1997. Print.
- One Step Away. "One Step Away: A Homeless Person Costs Taxpayers \$31k." The Philadelphia Inquirer. 30 July 2014. Web. 16 Feb. 2016.
- Park, June Ying Shann-Hwa. "Increased Homelessness and Low Rent Housing Vacancy Rates." Journal of Housing Economics 9.1-2 (2000): 76-103. Web.
- Poulos, Peter W. "Chicago's Ban on Gang Loitering: Making Sense of Vagueness and Overbreadth in Loitering Laws." California Law Review 83.1 (1995): 379. Web.
- Pritchett, W. Kendrick. Studies in Ancient Greek Topography. Berkeley: U of California, 1965. Print. University of California Publications. Classical Studies ; v. 1, Etc.
- Q13 Fox News Staff. "Homeless Man Charged in Deadly Attack on Married Couple in Tent under Magnolia Bridge." Q13 FOX News. 27 Aug. 2015. Web. 04 February 2016. <<http://q13fox.com/2015/08/27/homeless-man-charged-in-deadly-attack-on-married-couple-in-tent-under-magnolia-bridge/>>.
- Rosenberg, Yuval. "Household Income Dropped To Its Lowest Point Since 1995." Business Insider. Business Insider, Inc, 13 Sept. 2012. Web. 04 Mar. 2016.
- Ross, Benjamin. Dead End : Suburban Sprawl and the Rebirth of American Urbanism. Oxford ; New York: Oxford UP, 2014. Print.
- Rutkowski, Izabela, and Erin Durkin. "Plans Aired to Heal the Hated BOE 'scar'" NY Daily News. 7 Dec. 2010. Web.
- Saha, Abhishek. "A School under Metro Bridge Teaches These Delhi Slum Children." HindustanTimes, 5 July 2015. Web. 11 May 2016. <<http://www.hindustan-times.com/delhi/a-school-under-metro-bridge-teaches-these-delhi-slum-children/story-Qr3EV279SarAME4K6N8orL.html>>.
- Seattle Department of Planning and Development. Director's Report Transitional Encampment Interim Use Amendments. By DPD Director. Seattle, January 16, 2015. Print.
- Seattle Department of Transportation. Bridge Sufficiency Rating. Rep. Seattle, WA: SDOT, 2012. Print.
- Seattle, Washington, Municipal Ordinance 123854
- Seattle, Washington, Municipal Ordinance 124747
- Seattle/King County Coalition on Homelessness. Rep. Web. <http://www.homelessinfo.org/resources/one_night_count/2015_ONC_Poster-web.pdf>.
- Stockman, J.a. "Aircraft and Road Traffic Noise and Children's Cognition and

- Health: A Cross-National Study." *Yearbook of Pediatrics* 2007 (2007): 69-71. Web.
- Streissguth, Tom. "Historical Rate of Mortgage Foreclosures." Home Guides. SF Gate. Web. 04 Mar. 2016. <<http://homeguides.sfgate.com/historical-rate-mortgage-foreclosures-8868.html>>.
 - Sugimura, Diane M., and Mike Podowski. City Owned Transitional Encampment Sites Memo. Issue brief. Seattle: City of Seattle, June 29 2015. Print.
 - The Right to Adequate Housing. Geneva: Office of the United Nations High Commissioner for Human Rights, 2009. Print.
 - The United States Conference of Mayors. Hunger and Homelessness Survey. Rep. Washington D.C., 2014. Print.
 - Trachtenberg, Alan. *Brooklyn Bridge : Fact and Symbol*. Phoenix ed. Chicago: U of Chicago, 1979. Print. Phoenix Books (Chicago, Ill.) ; P828.
 - U.S. Department of Housing and Urban Development. 2015 CoC Homeless Populations and Subpopulations Report - WA-500: Seattle/King County CoC. Rep. Print.
 - U.S. Department of Housing and Urban Development. Environmental Planning Division,. HUD Noise Guidebook. By US Department of Housing and Urban Development. March 2009. Print.
 - U.S. Department of Justice. 2010 ADA Standards for Accessible Design. By U.S. Department of Justice. Washington, D.C.: Dept. of Justice, 2010. Print.
 - United Nations Fund for Population Activities. *The State of World Population 2007*. Web.
 - United States. *The United States Housing Act of 1937: As Amended, And Provisions of Other Laws And of Executive Orders Pertaining to the United States Housing Act of 1937, As Amended*. Washington, D.C: [U.S. Govt. Print. Off., 1938.
 - US Census Bureau. *Who Can Afford To Live in a Home?: A Look at Data from the 2006 American Community Survey*. By Mary Schwartz and Ellen Wilson. Washington D.C. Print.
 - US Department of Housing and Urban Development. 2007 - 2015 HIC Data by State. Nov. 2005. Raw data. Washington D.C..
 - Wang, Lucy. "Mexico City's Bajo Puentes Program Turns Vacant Lots Under Freeways into Prized Public Spaces." *Inhabitat*, 1 Aug. 2013. Web. 11 May 2016. <<http://inhabitat.com/mexico-city-turns-vacant-lots-under-freeways-into-prized-public-spaces-in-bajo-puentes-program/>>.
 - Wardhani, Dewanti, and Corry Elyda. "Jakarta Sees Rising Poverty, Widening Income Gap." *News: City. The Jakarta Post*, 29 Jan. 2015. Web. 11 May 2016.
 - Weise, Karen. "Housing's 30-Percent-of-Income Rule Is Nearly Useless." *Bloomberg.com. Bloomberg Magazine*, 17 July 2014. Web. 04 May 2016.

- Werner, Virginia C., and Chalana, Manish. Planning for Self-organized Homeless Camps : Policy, Community Relations, and Locational Process. Seattle]: U of Washington, 2014. Web.
- Whyte, William H., and Paco Underhill. City: Rediscovering the Center. University of Pennsylvania Press, 1988. Web...
- Williams, Lauren C. "Seattle Police to Revise Trespass Policy That Has Banished Hundreds." The Seattle Times. 10 Dec. 2010. Web. 29 May 2016.
- Wiltz, Teresa. "Anti-Panhandling Laws Spread, Face Legal Challenges." The PEW Charitable Trusts. 12 Nov. 2015. Web. 05 May 2016.
- Wong, Yin-Ling Irene, Jung Min Park, and Howard Nemon. "Homeless Service Delivery in the Context of Continuum of Care." Administration in Social Work 30.1 (2006): 67-94. Web.
- World Bank. "Urban Expansion in East Asia – Indonesia." News. World Bank, 26 Jan. 2015. Web. 11 May 2016.
- WSDOT. "Alaskan Way Viaduct - History." WSDOT. 2016. Web. <<http://www.wsdot.wa.gov/Projects/Viaduct/About/History>>.

Appendix: Scoring Table

Site Name	Transit Score	Mental Health Center	MH*	Substance Abuse Center	SA*	Family Services Centers	FS*	Food Banks	FB*	Thrift Shops	TS*	Services Total	Services Score	Current Use Score	Final Score	
Green Lake 1	58 19.33	0	0	0	0	0	0	6 4.2	0	0	0	4.20	18.97	6.32	0.00	25.66
Green Lake 2	58 19.33	0	0	0	0	0	0	6 4.2	0	0	0	4.20	18.97	6.32	100.00	58.99
Ballard Bridge North	55 18.33	0	0	1 0.3	0	0	0	2 1.4	0	0	0	1.74	7.86	2.62	50.00	37.62
Ballard Bridge South	55 18.33	0	0	1 0.3	0	0	0	2 1.4	0	0	0	1.74	7.86	2.62	0.00	20.95
Fremont Bridge	61 20.33	0	0	2 0.7	0	2 0.4	0	0	0	0	0	1.06	4.79	1.60	0.00	21.93
Portage Bay 1	73 24.00	1 0.34	0	4 1.4	0	0	0	6 4.2	1 0.14	0	0	6.04	27.28	9.09	100.00	66.43
Portage Bay 2	74 24.00	1 0.34	0	4 1.4	0	0	0	6 4.2	1 0.14	0	0	6.04	27.28	9.09	50.00	49.76
Portage Bay 3	70 24.00	1 0.34	0	4 1.4	0	0	0	6 4.2	1 0.14	0	0	6.04	27.28	9.09	50.00	49.76
Magnolia West	46 16.00	0	0	0	0	0	0	0	0	0	0	0.00	0.00	0.00	0.00	16.00
Magnolia East	50 16.00	0	0	0	0	0	0	0	0	0	0	0.00	0.00	0.00	0.00	16.00
IS Colonnade	60 20.00	0	0	2 0.7	0	0	0	0	0	0	0	0.68	3.07	1.02	100.00	54.36
Cherry Street	100 33.33	8 2.72	0	14 4.8	2 0.4	2 0.4	0	20 14	2 0.28	0	0	22.14	100.00	33.33	0.00	66.67
International District	100 33.33	4 1.36	0	7 2.4	2 0.4	2 0.4	0	12 8.4	4 0.56	0	0	13.08	59.08	19.69	0.00	53.03
190 Interchange	98 32.67	2 0.68	0	4 1.4	3 0.6	0	0	11 7.7	3 0.42	0	0	10.73	48.46	16.15	50.00	65.49
Spokane Street	63 21.00	0	0	0	0	0	0	0	0	0	0	0.00	0.00	0.00	50.00	37.67
Fauntleroy Expressway	53 17.67	2 0.68	0	0	0	1 0.2	0	0	0	0	0	0.87	3.93	1.31	0.00	18.98
Current Sites																
Ballard	49 16.33	0	0	1 0.3	0	0	0	2 1.4	0	0	0	1.74	7.86	2.62	100.00	52.29
Interbay	50 16.67	0	0	0	0	0	0	0	0	0	0	0.00	0.00	0.00	100.00	50.00
Othello	63 21.00	0	0	2 0.7	0	2 0.4	0	1 0.7	0	0	0	1.76	7.95	2.65	100.00	56.98
Tiny House	64 21.33	3 1.02	0	4 1.4	0	0	0	5 3.5	0	0	0	5.88	26.56	8.85	100.00	63.52

