

**C I N T R A F O R**

**Working Paper**

**84**

**A TECHNICAL EVALUATION OF THE MARKET FOR US  
WOOD WINDOWS WITHIN THE JAPANESE POST AND  
BEAM CONSTRUCTION INDUSTRY**

**Ivan Eastin  
Joseph Roos  
Paul Boardman**

**September 2001**

^ ^ ^ ^ ^  
^ ^ ^ ^ ^  
^ ^ ^ ^ ^  
^ ^ ^ ^ ^

Center for International Trade in Forest Products  
University of Washington  
College of Forest Resources  
Box 352100  
Seattle, WA 98195



# C I N T R A F O R

## Working Paper 84

### A TECHNICAL EVALUATION OF THE MARKET FOR US WOOD WINDOWS WITHIN THE JAPANESE POST AND BEAM CONSTRUCTION INDUSTRY

Ivan Eastin  
Joseph Roos  
Paul Boardman

September 2001

Center for International Trade in Forest Products  
University of Washington  
College of Forest Resources  
Box 352100  
Seattle, WA 98195

This material is based upon work supported by the State of Washington Office of Trade and Economic Development and the Cooperative State Research Service, US Department of Agriculture. In addition, logistical support in Japan was provided by the American Forest & Paper Association Japan Office and the Softwood Export Council Japan Office. Any opinions, findings, conclusions, or recommendations expressed in this publication are those of the author(s) and do not necessarily reflect the view of the funding agencies.



## EXECUTIVE SUMMARY

In response to weakened demand for imported wood building materials within the 2x4 segment of the housing industry, a number of US exporters have begun to explore opportunities in the post & beam and prefabricated housing markets. In order to develop a better understanding of the problems and opportunities confronting US wooden windows in the post & beam segment of the Japanese residential construction industry, this project was designed to integrate with the ongoing market development programs being undertaken by OTED. The objectives of this project are to: 1) describe the factors driving technological change in the Japanese post and beam industry, 2) characterize and describe the major construction technologies used in the post and beam industry, 3) document the technical specifications and construction details required for wooden windows within the post and beam industry, and 4) recommend strategies for increasing the competitiveness of US wooden windows in the Japanese post and beam industry.

This results of this project support the idea that standard US wooden windows can be incorporated into the post and beam construction system used in Japan. However, product design and accessories as well as the range of support services offered by Japanese window manufacturers have a substantial impact on the competitiveness of US windows in Japan. US wooden window manufacturers (including clad wood windows) need to ensure that their windows are properly installed, finished, and maintained in order to ensure that their long-term durability and performance meets Japanese expectations. Significant technical and installation issues exist and US manufacturers must take the initiative to develop training programs and strategies to effectively address these issues so that window performance meets homeowner expectations.

While the fire codes in Japan describe the performance standards that windows must meet, it is interesting to note that the fire codes specify that aluminum is a non-combustible material and therefore exempted from the performance standards. Several people in Japan noted that, although it is difficult for wooden windows to meet the performance standards specified in the fire codes, to date approximately 15 wooden windows have been certified as meeting the fire code criteria. In contrast, they noted that most aluminum windows used in Japan, if exposed to the test criteria described in the fire tests, would melt and fail early on in the test process. It is obvious that the exemption of aluminum as a non-combustible material has played a critical role in providing aluminum window manufacturers with their dominant position in the industry.

During our visits to construction sites it was noted that the majority of windows had not been sized to fit the rough opening between adjacent posts. Rather, the rough opening for these windows was often framed in between the posts to accommodate the size of each window. Given this practice of in-fill framing for windows, it would be no more difficult for Japanese carpenters to frame in US standard size windows than Japanese metric size windows, a fact that our discussions with Japanese builders and carpenters confirmed. However, the different post sizes used in post and beam construction means that the casing width used to frame out the window in the wall varies based on the size of post being used. To address this complication, Japanese carpenters usually rip the window casing from a wide piece of casing after the window has been installed in the rough opening. So what is limiting the specification and use of US wood windows in Japan? Certainly price is one factor. But beyond this, product design and the range of services offered are equally important factors.

Another factor that impacts the window specification decision relates to the fact that Japanese home builders are usually provided with a range of services by domestic window manufacturers and wholesalers that are often not available from US manufacturers and exporters. These services include extended credit (*egata*), on-site product delivery, on-site installation crews, and locally available parts and replacement windows.

This research suggests that standard US window sizes can be easily accommodated within the post and beam construction system used in Japan. However, product design and the range of services being offered have a substantial impact on the competitiveness of windows in Japan. US wood window manufacturers should at least consider the following factors to increase the competitiveness of their products in the future: 1) establishing of training and education programs for Japanese builders and carpenters, 2) developing a certification program for

Japanese window installers and carpenters, 3) producing and distributing a generic window installation manual in Japanese, and 4) maintaining technical support, parts and product inventory in Japan. This research clearly shows that with a well thought out strategy, US wood window manufacturers could be competitive in the Japanese post and beam segment of the residential construction industry.

## TABLE OF CONTENTS

	Page
<b>Executive Summary</b> .....	<b>i</b>
<b>List of Tables</b> .....	<b>v</b>
<b>List of Figures</b> .....	<b>vi</b>
<b>Opportunity/Need/Objectives</b> .....	<b>1</b>
PROJECT OBJECTIVES .....	2
PROJECT APPROACH .....	2
<b>Introduction</b> .....	<b>3</b>
OVERVIEW OF THE JAPANESE RESIDENTIAL CONSTRUCTION MARKET.....	3
Residential Housing Types .....	5
Residential Housing Industry Structure.....	6
Changing Nature of the Residential Housing Market .....	7
OVERVIEW OF THE JAPANESE DOMESTIC WINDOW MARKET .....	8
<b>Type of Fixture and Combination (equivalent of one or another)</b> .....	<b>15</b>
OVERVIEW OF MAJOR JAPANESE WINDOW MANUFACTURERS .....	18
US EXPORTS OF WOODEN BUILDING MATERIALS TO JAPAN.....	31
<b>Constraints and opportunities for US wooden windows in Japan</b> .....	<b>37</b>
HISTORICAL WINDOW DESIGNS .....	37
FIRE SAFETY REGULATIONS AND FIRE ZONES .....	39
Fire regulations for wooden windows .....	40
Fire tests for wooden windows .....	41
THE IMPACT OF CHANGES IN THE JAPANESE HOUSING CONSTRUCTION LAWS AND REGULATIONS .....	45
Summary of Major Regulatory Changes in the Residential Construction Sector .....	45
<b>Current Problems Impacting the Competitiveness of US Wood Windows in Japan</b> .....	<b>49</b>
THE IMPACT OF CULTURAL PREFERENCES ON WINDOW DESIGN .....	49
METRIC SIZE OF BUILDING MODULE .....	49
WEATHERPROOFING AND FLASHING .....	51
RAINSCREEN SIDING SYSTEM (DOBUCHI) .....	53
HOME BUILDER EXPECTATION OF A BROAD RANGE OF ACCESSORIES AND SERVICES .....	58
LACK OF TECHNICAL SUPPORT .....	60
READY AVAILABILITY OF REPLACEMENT WINDOWS AND PARTS .....	60
LACK OF WINDOW MAINTENANCE AND UPKEEP BY HOMEOWNERS .....	60

<b>Conclusions.....</b>	<b>63</b>
<b>Bibliography .....</b>	<b>65</b>
<b>Appendix A: Japanese Wood Window Manufacturers.....</b>	<b>69</b>
<b>Appendix B: An Overview of the Re-Examination of the Construction Code Performance Standards Initiative for Fire Resistant Structures and Fireproof Materials. ....</b>	<b>71</b>
<b>Appendix C: Summary of Fire Door Test Methodology .....</b>	<b>75</b>
<b>Appendix D: Certified Fire Resistant Japanese Wood Windows .....</b>	<b>77</b>
<b>Appendix F: Summary of Changes in the Japanese Housing Construction Laws.....</b>	<b>81</b>
<b>Appendix G: Japan Wood Window Survey and Results .....</b>	<b>83</b>
<b>Appendix H: US Exports of Wood Products to Japan, 1989-1999 .....</b>	<b>89</b>

## LIST OF TABLES

	<b>Page</b>
Table 1. Window types installed in new single-family houses, 1993-1997. ....	11
Table 2. Sash materials used for residential windows, 1997. ....	11
Table 3. Sash colors used for residential windows, 1997. ....	12
Table 4. Table of Japan Energy Standards, by region. ....	15
Table 5. Summary of fire test methods and criteria. ....	44
Table 6. Summary of technical observations based on construction site visits in Japan. ....	61

## LIST OF FIGURES

	<b>Page</b>
Figure 1. A comparison of US and Japanese housing starts, 1965-2000. ....	4
Figure 2. Housing starts in Japan and the ratio of wood housing starts, 1965-2000. ....	5
Figure 3. Typical layout of windows in a traditional Japanese home. ....	9
Figure 4. Types of windows commonly used in Japanese residential housing. ....	9
Figure 5. Mold and staining is a common problem with aluminum windows in Japan. ....	10
Figure 6. Mold and staining is caused by condensation and water infiltration through aluminum windows. ....	10
Figure 7. Retractable window screens have become commonplace in new home construction. ....	13
Figure 8. Regional energy classification system used in Japan. ....	15
Figure 9. Manual or remote controlled weather screens provide privacy and protection from the elements and intruders. ....	19
Figure 10. Aluminum clad wood casement window from the Decorte window line. ....	19
Figure 11. Japanese manufacturers provide builders and homeowners with a wide range of product features and options. The weather screen in this figure has 12 combinations of cap design and screen colors, in addition to a power driven option and remote control. ....	20
Figure 12. Product literature highlights the thermal and soundproofing characteristics of YKK windows. ....	21
Figure 13. Corner details of YKK aluminum clad wood windows. ....	21
Figure 14. Low profile weather screen on a double slider aluminum clad wood window. ....	22
Figure 15. A combination weather screen with louvers, this window combines both security and natural lighting attributes. ....	22
Figure 16. Product advertisement targeting the remodel market. ....	23
Figure 17. The soundproofing qualities of Shin Nikkei windows are emphasized. ....	24
Figure 18. The Clearbirch product line includes aluminum clad wood windows and doors. ....	24
Figure 19. Double slider aluminum clad vinyl window with side weather screens. ....	25
Figure 20. Promotional flyer highlighting the range of window styles and window accessories offered by Tateyama. ....	26
Figure 21. A small wooden window manufacturer located in Chino City, Nagano prefecture. ....	28
Figure 22. A stack of composite lumber that will be processed into window components. ....	28
Figure 23. Japanese window manufacturers produce a wide range of stock and custom window sizes. ....	29
Figure 24. Worker installing a glass pane in a window. ....	29
Figure 25. Window blanks are manually cut to size for assembly. ....	30
Figure 26. Workers manually apply a primer/sealer onto wooden window components. ....	30
Figure 27. US primary and secondary wood products exports to Japan, 1989-1999. ....	32
Figure 28. Japanese imports of wooden windows, doors, tategu, and transoms, 1989-1999. ....	32
Figure 29. Shoji door ready for shipping. A paper face and back will be applied by another company prior to being installed. ....	33
Figure 30. Intricately carved panels (called rama) are often installed above shoji doors in traditional tatami rooms. ....	33
Figure 31. US exports of wooden doors and windows to Japan, 1989-2000. ....	34
Figure 32. US share of Japanese wood window, door and tategu imports, 1988-1999. ....	34
Figure 33. Traditional wood windows were often poor quality and poorly maintained. ....	38
Figure 34. Poor quality windows and construction practices contributed to moisture infiltration around and through wood windows. ....	38
Figure 35. While traditional window designs were interesting poor quality adversely affected performance in Japan's hot, humid and wet climate. ....	39

Figure 36.	Promotional brochure for a fire resistant wood window manufactured by Asahi Glass Company. ....	42
Figure 37.	Promotional brochure for fire resistant Kimado wood widow. ....	43
Figure 38.	Windows are often framed in between the structural posts in Japan. ....	50
Figure 39.	Small window overhangs on this older wooden house are an effective way to deflect rain water away from the window opening. ....	51
Figure 40.	Some home builders build small accent roofs to protect windows from water flowing down the side of the wall. ....	52
Figure 41.	Rain flowing down the exterior wall can penetrate this unprotected window opening and penetrate into the wall cavity as a result of hydrostatic pressure. ....	52
Figure 42.	Even in protected areas of the house, using waterproof tape around windows will help prevent moisture related problems. ....	53
Figure 43.	Wood dobuchi strips (20mm by 40 mm) are used in the rain screen siding system. ....	54
Figure 44.	Windows are installed flush onto the dobuchi strips, thereby necessitating the use of a wider casing for the interior trim. ....	54
Figure 45.	These windows were installed flush with the wall and the dobuchi strips were added. This is not a recommended installation technique and can result in the exterior wall surface being flush with the window surface as shown in Figure 34. ....	55
Figure 46.	Technical drawing of a double slider window installed between posts with a dobuchi rain screen siding exterior. Note the space between the exterior siding and the window frame that is filled with a silicon caulk. ....	56
Figure 47.	Technical drawing of double hung window with the dobuchi siding system. Note that the window is pulled away from the exterior wall with a spacer and the exterior siding butts up against the corner trim, not the window frame. ....	57
Figure 48.	Removable joint strip covers the small gap where the sash butts up to the window. Note that the interior sill of the window is white plastic lumber with a wood grain impression. ....	58
Figure 49.	Some window manufacturers offer accent roofs as an option with a window package. ....	59
Figure 50.	Detailed view of a shiiki (bottom track) for a sliding shoji screen illustrating how it slides under the casing return. ....	59



**Traditional Japanese wooden windows and shutters provide an interesting exterior pattern on older Japanese post and beam homes.**

## **OPPORTUNITY/NEED/OBJECTIVES**

The current economic downturn in Japan has seen residential housing starts drop from 1.64 million in 1996 to 1.39 million in 1997 to 1.23 million in 2000. The impact of the decline in Japanese housing starts on firms in Washington State has been dramatic. US Department of Commerce statistics indicate that PNW exports of primary and value-added wood products to Japan in 1997 were down by 32.8 percent and 17 percent, respectively. As a reflection of this, one regional association of wood products exporters in the Pacific Northwest has seen its membership decline by more than a third with almost 40 percent of the membership losses being attributed to business failures.

Recent exporter interest has focused on developing the market for North American-style 2x4 homes in Japan. The results of these efforts have helped to develop a better understanding of the opportunities and problems confronting North American-style 2x4 homes in Japan. While recognizing that the North American-style 2x4 construction technology has been remarkably successful in Japan, it still represented just 6.4 percent (79,114 homes) of total housing starts in 2000. In contrast, traditional wooden post & beam housing starts represented 36.3 percent (446,359 homes). Insights gained from the 2x4 technology transfer projects suggest that more effective strategies could also be developed to increase the competitiveness of US wood products and wooden building materials in the post and beam segment of the Japanese residential construction industry.

In a sense, the success of imported housing in Japan was facilitated by a series of MOC (now MLIT) and MITI (now METI) initiatives that emphasized the opportunity for North American-style 2x4 construction technology to help reduce construction costs and improving housing quality. As a result, US manufacturers of wooden building materials saw their exports increase substantially over the period 1989-1996. However, the weakness of relying on growth within a specific market segment (2x4) to support export growth for wooden building materials has been demonstrated over the past two years. During the period 1996-2000, 2x4 housing starts dropped from 93,693 to 79,114.

In response to weakened demand for imported wood building materials within the 2x4 segment of the housing industry, a number of US exporters have begun to explore opportunities in the post & beam and prefabricated housing markets. To their surprise, they have found that the measures taken by the Japanese government to promote the import of wooden building materials do not extend to these other segments of the housing market. For example, while softwood lumber used in 2x4 housing is not required to be JAS certified through mutual recognition of US lumber grade stamps, softwood lumber used in other segments of the housing market is still required to have a JAS grade stamp in order to meet GHLC mortgage requirements. This and a number of other non-tariff barriers (e.g., reduced mortgage rates for post & beam homes using domestic lumber and fire certification requirements for windows and doors used in fire and quasi-fire zone areas) have adversely impacted the competitiveness of US value-added wood products in the post & beam and prefab segments of the Japanese housing market.

Another important problem confronting US manufacturers and exporters relates to the product specification process employed by builders within the post & beam and prefabricated segments of the housing industry. A number of US exporters have indicated that, while Japanese contractors building North American-style 2x4 homes tend to source many of their building materials (e.g., lumber, sheathing panels, doors, windows, flooring and moulding) in the US, contractors building post & beam and prefabricated homes are much more reluctant to include US building materials as options for their customers. Obviously, some of this reluctance can be attributed to the broad selection of wood and non-wood products available in the domestic market as well as to the established business relationships and product support services that Japanese builders have developed with domestic manufacturers and suppliers. However, some of this reluctance may be attributable to non-tariff barriers and discriminatory provisions within the Building Standards Law and the impact of the Housing Quality Assurance Act.

Finally, rising labor costs and a shortage of skilled carpenters have contributed to relatively high construction costs in the post and beam industry. The Japanese government, in an effort to reduce housing costs, has encouraged builders and housing manufacturers to look for ways to make high quality housing more affordable. This effort has

resulted in component manufacturers and builders working together to develop “rationalized” post and beam construction systems, and it has had a substantial impact on how traditional post and beam houses are built. Today there are a growing number of “rationalized” construction systems being used and, because each is substantially different from the others, each has the potential to require different technical specifications for component systems.

## **PROJECT OBJECTIVES**

In order to develop a better understanding of the problems and opportunities confronting US wooden windows in the post & beam segment of the Japanese residential construction industry, this project was designed to integrate with the ongoing market development programs being undertaken by OTED. The objectives of this project are to: 1) describe the factors driving technological change in the Japanese post and beam industry, 2) characterize and describe the major construction technologies used in the post and beam industry, 3) document the technical specifications and construction details required for wooden windows within the post and beam industry, and 4) recommend strategies for increasing the competitiveness of US wooden windows in the Japanese post and beam industry.

## **PROJECT APPROACH**

Information for this project was collected in the US and Japan. A thorough review of the secondary literature was conducted to provide information relating to the Japan post and beam industry. In addition, product descriptions, technical information, and installation instructions (where available) were collected from the internet web sites of the major Japanese window manufacturers. Supplemental data on the post and beam industry was collected in Japan from the Ministry of Land, Infrastructure, and Transportation (the former Ministry of Construction), industry associations, and the Japan Wood Products Information Center. This information forms the basis for characterizing the Japanese post and beam industry. It also helps develop a better understanding of the factors that affect the competitiveness of US wood windows in Japan. Finally, discussions with US manufacturers and exporters of wooden windows helped to identify additional factors that adversely impact the performance and competitiveness of US wood windows in Japan.

## INTRODUCTION

### OVERVIEW OF THE JAPANESE RESIDENTIAL CONSTRUCTION MARKET

The greatest single end use for imported wood in Japan is the housing industry (JAWIC undated). In 1992, it was estimated that 79% of lumber shipments in Japan went into housing construction (Gaston 1997). Japan's residential housing market has consistently been one of the largest and most dynamic in the world. Since 1987, Japan's housing starts have been approximately equal to those in the United States even though Japan has only 46.9% of the population and 3.9% of the land area of the US.

A combination of factors have historically supported the relatively high number of housing starts in Japan, including: active construction of rental housing, low mortgage interest rates, active government support for inexpensive housing, sustained growth of per capita income, population growth, rapid turnover of existing housing stock, large migration to urban centers, large volumes of existing low quality housing in need of replacement, improved tax benefits for housing, and stable land prices (JETRO 1995; Robertson and Waggener 1995; Eastin 1999). For example, since 1950 the population in Japan has increased by 50% while household size has fallen from 5.02 to 3.01, suggesting a trend from the traditional extended family to a smaller nuclear family (Robertson and Waggener 1995). The increase in population and the number of nuclear family households has helped support the demand for housing.

However, recent population statistics and demographic projections clearly show a declining birth rate and an increasing life expectancy in Japan. This combination of demographic trends suggests that the population in Japan will begin to decline after 2010. As a result, demand for new housing is also expected to decline and most demographers estimate that housing starts in Japan will stabilize at around 1.1 million from 2002-2010 before declining to a level of approximately 800,000 to 900,000 starts per annum.

Housing starts in the US and Japan totaled 1.53 million and 1.23 million units, respectively, in 2000 (Figure 1). US and Japanese housing starts have tended to follow world economic trends and exhibit differences based on domestic trends as well. Both countries experienced rapid economic growth in the early 1970s as indicated by the high level of housing starts until 1973 when the OPEC oil crisis contributed to a decline in the number of new housing starts in both countries. Both countries also experienced housing slumps in the early 1980s and early 1990s, in response to the second oil crisis and the Persian Gulf War, respectively.

In Japan, housing starts were very high during the late 1980s (the so-called Bubble-Economy) and in 1996. 1996 was the first time since 1987 during the Bubble Economy when housing starts exhibited a double-digit increase over the previous year. The high number of housing starts in 1996 can be attributed in part to the rebuilding activity following the 1995 Hanshin Earthquake in Kobe. The earthquake damaged approximately 147,600 houses (Japan Lumber Reports 1995) and displaced over 400,000 households (Pacific Rim Wood Market Report 1996). Housing starts were also high in 1996 because homeowners rushed to purchase houses before the Ministry of Finance increased the national consumption tax from 3% to 5% on April 1, 1997. The increased consumption tax applied to housing construction and consumers wanted to avoid paying hundreds of thousands of yen in extra taxes.

The subsequent dramatic decrease in housing starts in 1997 can be attributed to simultaneous occurrence of several factors: the increase in the consumption tax from 3% to 5%; an increase in the cost of living due to the removal of the income tax reduction provision, an increase in the cost of medical care, which was expected to total 9 trillion yen; a lack of funds for large public works projects by the government due to anxiety over the troubled banking system; and an overall slump in the economy (Japan Lumber Reports 1998a). The government's implementation of several fiscal policies was expected to knock a full point off private spending in 1997 (Bremner and Takahashi 1996). Finally, The Asian economic Crisis that occurred in late 1997 caused widespread currency devaluations and economic instability throughout Asia.

Since 1997, the continuing economic difficulties in Japan have had a devastating impact on the Japanese housing industry, sending thousands of contractors out of business and reducing housing starts from 1.66 million units in 1996 to just 1.23 million units in 2000 (and the outlook for 2001 is approximately 1.1 million units). Not surprisingly, the decline in housing starts has had an adverse effect on US wood product exports to Japan, with exports of primary wood products declining by 53% and secondary wood products declining by 46% from 1996 to 1999. Compounding the impact of the economic recession and the decline in housing starts on US exports has been the surprising strength of the yen and the relative weakness of the Canadian dollar and the Euro. The impact of these currency changes has been a strong US dollar that has reduced the competitiveness of US wood products in Japan. As a result, European exports of softwood lumber to Japan have increased dramatically, largely at the expense of US and Canadian hemlock exports. From 1989-2000, the US market share for softwood lumber declined from 48.3% to 5.6% and the Canadian market share decreased from 50.9% to 43.9%, while the European market share increased from 0% to 25.1%.

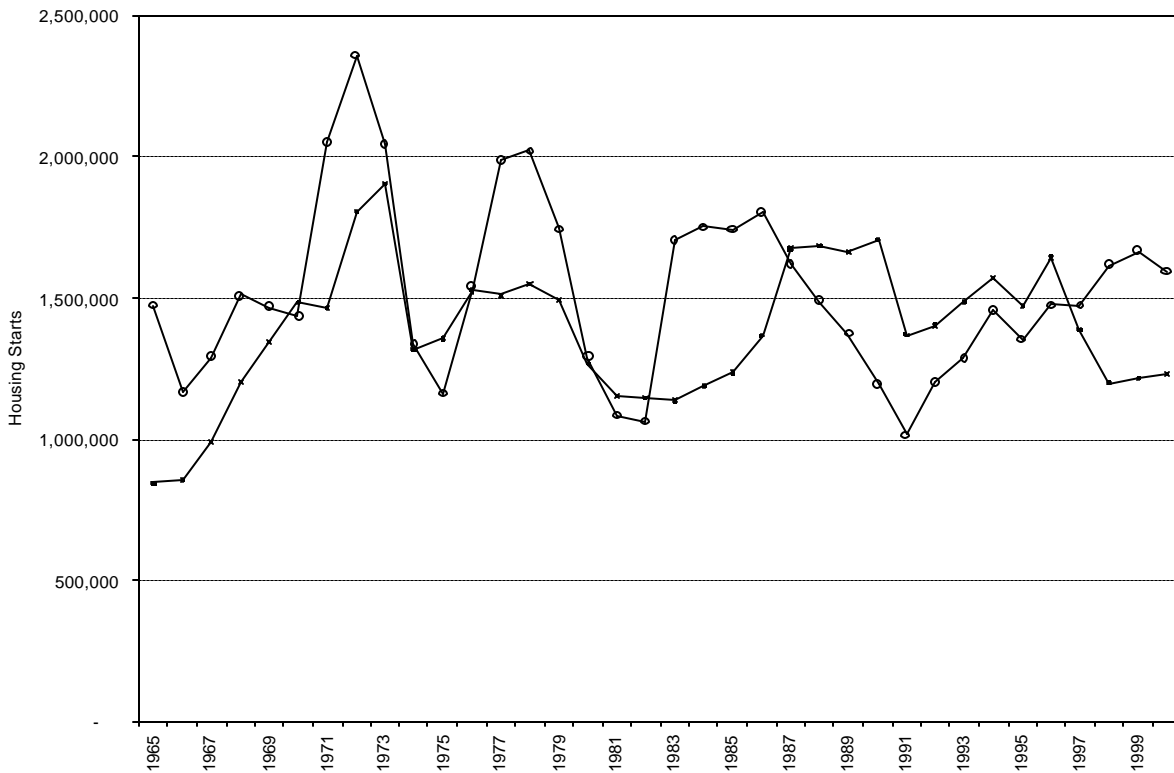
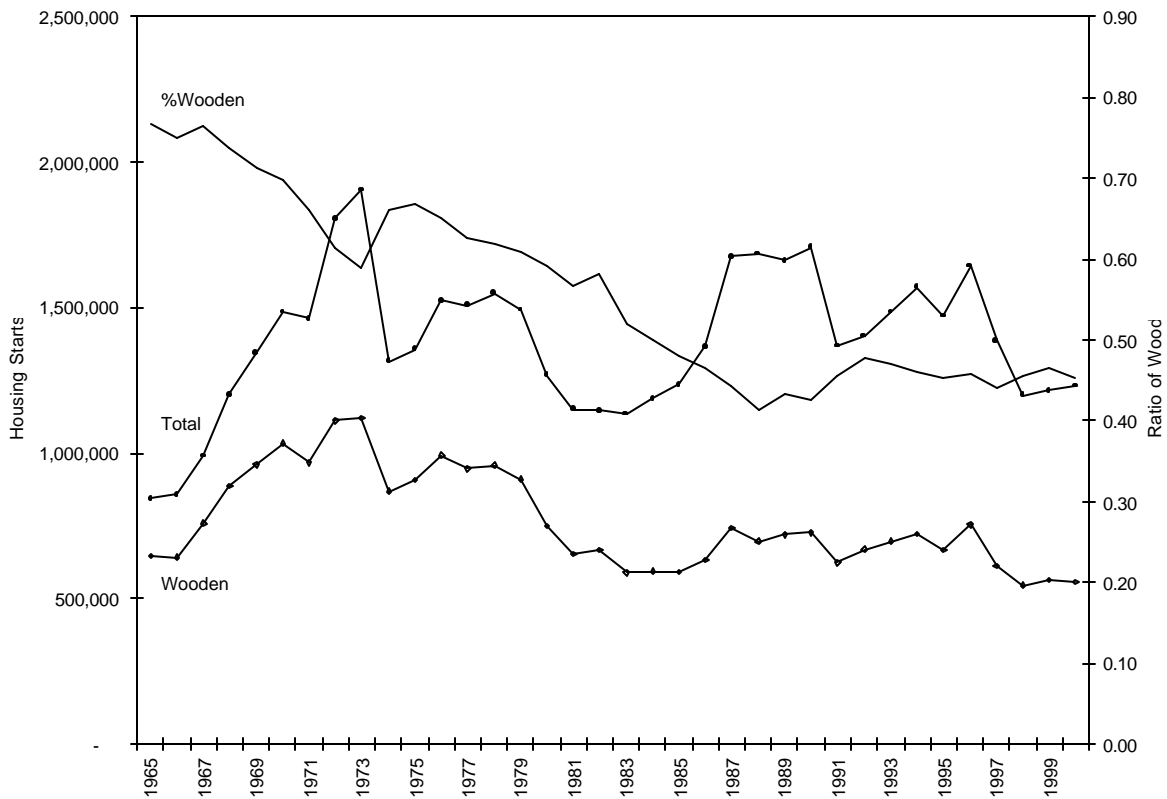

Figure 1. A comparison of US and Japanese housing starts, 1965-2000.



**Figure 2. Housing starts in Japan and the ratio of wood housing starts, 1965-2000.**

### Residential Housing Types

One way that residential housing can be classified is by occupancy type: single-family detached versus multiple-family collective housing residences (including apartments (mansions and condominiums) (JETRO 1996a). In 1999, multi-family homes made up the majority of total housing starts at 50.7%, down from 53.6% in 1998. Despite this drop, there is a clear trend towards multi-family residences to house the dense population in the larger urban areas. In Tokyo for example, 65.3% of all residences are multi-family units. Throughout all of Japan however, multi-family units comprise only 41.8% of the new construction.

Housing starts can also be segmented based on the type of structural material used (e.g., wood, steel, or reinforced concrete). Wood has always been an important part of the Japanese culture and trees were thought to be the places where the native gods first descended to earth. As a result, wood has traditionally had strong religious meaning and most temples and shrines are built using wood. The Japanese people are deeply drawn to the aesthetic beauty, strength, and aroma of wood, and Japanese consumers place a high value on using wood in their homes. A survey conducted by the Japanese Prime Minister's Office showed that, if given a choice, nearly 80% of Japanese homeowners would prefer to live in a wood house (Coaldrake 1990).

Residential construction was dominated by wooden housing well into the mid-1970s, accounting for almost two-thirds of all housing in 1976. However, the continued growth in multi-family housing and prefabricated single family housing has contributed to the declining share of wooden housing and in 2000 wooden housing represented just over 45% of all housing starts in Japan. There are three main types of wooden housing built in Japan: traditional Japanese post-and-beam houses, 2x4 (both Japanese-style and North American-style), and prefabricated houses. The 2x4 housing industry has experienced healthy growth within the wooden house segment (JETRO

1996a; Japan Lumber Journal 1998a). Japanese houses are typically replaced every 20-25 years and most new homes are built on sites where the previous home has been demolished (Eastin 1994). Given the poor quality of most of the older post-war housing, it is generally considered more cost-effective and efficient to demolish these older homes rather than repair or remodel them (Eastin 1994).

The type of financing used for new houses is another way in which government and industry associations have segmented the residential housing industry (Japan Lumber Journal 1998a). The two sources of construction financing are private and public. The majority of construction financing in Japan is through private sources at 55.7% in 1999. The remaining mortgage financing is obtained through public mortgage lenders, in particular the Government Home Loan Corporation (GHLC), which provided 37.5% of all mortgage funding in 1999. The GHLC was established by the government in 1950 to provide middle-class home buyers with low interest mortgages (JETRO 1995). The interest rate for GHLC mortgage loans is well below market interest rates and in April, 2001 the GHLC interest rate was 2.55% (Japan Lumber Journal 2001). The GHLC has strict rules regarding eligibility criteria for potential borrowers and house size. In 1993, the income ceiling for eligible borrowers was raised to ¥13.225 million to allow a larger proportion of the population to qualify for GHLC mortgage loans. Financing was also expanded to houses up to 2,580 ft<sup>2</sup> of floorspace, from 2,370 ft<sup>2</sup>. This resulted in a record 667,118 mortgages being granted by GHLC in 1994.

### **Residential Housing Industry Structure**

Housing is mainly built in New Towns and owner occupied in-fill housing (JETRO 1996a). Subdivision sales are like sales in the US where a developer sells both the new house and land in a new residential development. These developments, often referred to as *new towns*, are generally built by companies that specialize in large subdivision developments. They develop land tracts, sell the houses, and usually design and build the house. Other companies acquire small tracts of land to develop and sell houses. These are the *tateuri* (build and sell) or *mansion* (condominium) companies. Incidentally, in Japan, the term *mansion* refers to high-rise apartments or condominiums that generally have a smaller floor area than detached single-family houses.

Owner occupied housing refers to new houses built for a personal dwelling. In most cases, the homeowner demolishes an existing home and builds a new house in its place. These types of houses are mostly custom built and, given the very high cost of land in urban areas of Japan, they are designed to fit the shape and size of the lot in order to maximize the floor area (McKellar 1995). The owner has very strict specifications for their new house and their input is constantly solicited throughout the design and construction process. As suggested by Leonard Guss Associates, Inc. (1992), homes with a unique appearance are desired and “cookie-cutter” houses do not do well in this market segment.

JETRO (1996a) describes the three main types of Japanese single-family house builders as: 1) large, national housing manufacturers, 2) medium-sized, regional housing companies, and 3) small, local home builders (*kohmuten*) and/or carpenters. The large housing manufacturers have powerful nation-wide sales networks. In fiscal 1999, there were eight large housing manufacturers who each had annual sales of approximately 10,000 units or more. The eight largest home builders in Japan include: Sekisui House (63,300 homes built in 1999), Daiwa House (38,000), Misawa Homes (34,000), Sekisui Chemical (24,180), National House Industries (18,300), Asahi Chemical Industries (15,800), Sumitomo Forestry (10,550), and Mitsui Home (9,600). These firms often supply building materials manufactured in their own factories even though the actual construction may be subcontracted out to smaller companies. The regional housing companies are based in the local communities and they provide design, sales, and construction services. The medium-sized companies typically build approximately 50 to 100 houses annually. These companies see high potential growth because they construct most of the 2x4 houses whose sales are expected to grow rapidly (Pacific Rim Wood Market Report 1996). On many occasions, the actual construction is subcontracted to smaller companies.

The smallest housing companies do most of the actual construction of houses for both themselves and for the larger companies. The small companies include self-employed carpenters who work as labor subcontractors. Most small companies build roughly three to five houses annually. Historically, small companies have controlled the largest

market share within the housing industry. The Japan 2x4 Home builders Association reports that most 2x4 houses are built by small and medium sized companies, while the large companies primarily build Japanese-style 2x4 houses employing the 3x6 tatami module (Roos and Eastin 1998). The large national companies have seen their market share increase to roughly 20 to 30% of the single-family housing market, partly because they also build steel and reinforced concrete multi-family units whose market share has been growing in urban areas.

A survey by the Management and Coordination agency estimated that there were 92,500 companies directly involved in wooden house construction in Japan (JETRO 1996a). In addition, there were about 62,000 firms operating mainly as carpentry subcontractors. The average number of employees per housing company was 5.1, while it was 2.9 per carpentry business. These figures illustrate the fact that the majority of companies in the residential construction industry are small operations.

When a large housing company gets an order to build a house, it typically will subcontract the work to a construction company that in turn, subcontracts work to companies that specialize in various sub-trades such as foundation, framing, roofing and electrical work. After this level of subcontractor, there is usually another layer of subcontractors that do the construction. Levy (1990) suggests that there are potentially seven layers of subcontractors between the consumer and the actual workers who build the house. This complex system is referred to as the “multi-layered” or “multi-tiered” subcontracting structure (JETRO 1996a). This system makes building a house in Japan more complex, more time consuming, and more expensive than in the US. In addition, building a house in Japan is also different than in the US because it is a common practice to include labor costs when invoicing material costs. This practice, called the *total material and labor* system, makes it difficult to calculate the construction cost of a house (JETRO 1996a).

### **Changing Nature of the Residential Housing Market**

Historically, post-and-beam housing had dominated the residential housing market. In 1963, 86.2% of all residential housing starts utilized the traditional post-and-beam construction method (JAWIC 2001). However, in 2000, they represented only 36.3% of all new residential housing starts as substantial inroads have been made by the steel and ferro-concrete construction industry (JAWIC 2001). Since 1968, the share of multiple-family housing units has increased 16.6%. High-rise, high-density condominium or “mansion” buildings characterize multiple-family housing units where steel and concrete are used for structural integrity as specified in the building codes. In large cities such as Tokyo and Osaka, they are an absolute requirement to house the enormous population. Japan is already one of the most densely populated countries in the world at 857.1 people per square mile. However, the population density increases to 2,571.3 people per square mile because only about 33% of Japan is habitable. The other 67% is made up of mountains, farmland, forests, and uninhabitable terrain. In addition, for many people, mansions are more affordable than detached single-family homes (WWPA 1994). The main drawback to mansions is that their floor space is substantially smaller than the typical single family home. On average, the floor space of a single-family home is 2.7 times greater than a mansion or condominium (JETRO 1996a).

Inroads by prefabricated houses and 2x4 houses have further reduced the market share of post-and-beam houses. Prefabricated units built from all materials comprised about 8.7% of residential housing starts in 1999 (Japan Lumber Journal 2000a). In addition, 2x4 units comprised about 6.4% of residential housing starts in 2000. Post-and-beam housing construction has also decreased because of the aging labor force. Many young people dislike entering the construction industry because of the dirty and dangerous work involved. The construction industry is not viewed as a favorable place to work because of a poor industry safety record in past years. It also takes seven years of apprenticeship training to become a post-and-beam carpenter-another factor, which discourages entrance into this profession (Cohen *et al.* 1996). As a result, the average age of a carpenter is now almost 54 years old.

Although Japan might traditionally have been characterized as a culture that shuns outside ideas and people. Consumers in Japan, however, increasingly prefer the look of western-style architecture and the open floor plan in western homes (JETRO, 1996a). This is especially true with the younger generation where a greater proportion of the population has lived or traveled overseas. The strong yen and the bubble economy of the 1980s and early 1990s allowed many Japanese to travel overseas and experience other cultures and lifestyles. In addition, there are

significant numbers of Japanese who have lived overseas as a result of business transfers within a multinational corporation, overseas study, and homestay visits. These Japanese have seen the quality of housing in other cultures and are now demanding this same high quality for their own houses in Japan.

To say that many Japanese are dissatisfied with the quality of housing in Japan would understate the situation. A 1993 MOC survey showed that 49.4% of households are not satisfied with the condition or quality of their housing condition. Among the more commonly cited reasons are an inadequacy of space, inferior layout of rooms and facilities, poor noise and inadequate thermal insulation, and general wear and tear of their houses (JETRO, 1996a). There is great interest in matching the quality of their housing with their wealth and consumer spending power. In addition, a recent article in the Japan Times cited the increasing number of homeowner complaints about shoddy construction practices in new homes. Over the period 1991-2000 complaints about housing defects increased by 325%, with leaky roofs, cracked walls, sloping floors/walls, creaky floorboards, and unclosable doors and windows being the most common complaints (Japan Times 2000, 2001).

## **OVERVIEW OF THE JAPANESE DOMESTIC WINDOW MARKET**

North American 2x4-style wood frame houses are known for their structural strength and insulation values. As part of this system, North American windows are designed to provide a combination of performance and energy efficiency. In contrast, the Japanese building tradition has placed strong emphasis on allowing the comforts of nature, such as sunlight or a cool summer breeze, to enter the house through windows and doorways. Windows are seen as a bridge to nature. It is not unusual for a house in Japan to have two or three sliding patio doors that allow natural sunlight to enter the house and the summer breeze to flow through the house. Bay windows are also very popular in both the kitchens and bathrooms. A typical Japanese house has several 2-way slider windows, 2-way slider patio doors, casement windows, awning windows, and possibly a bay or bow window (Figures 3 and 4). In traditional Japanese houses, double slider windows are used where single and double hung windows would typically be used in North American homes.

Recently, especially with the advent of North American competition, the Japanese market has come to appreciate well-insulated houses. Japanese window companies have developed insulated glass, vinyl windows, aluminum clad wood windows, and combination aluminum-vinyl windows. Another factor that is important in the Japanese window market is the soundproofing capability of a window. Japan has extremely dense housing and it is important to maintain a peaceful environment within the house while protecting neighbors from noise as well. Additionally, moisture build up, or sweating, on the interior surface of the window and frame occurs frequently in humid Japan and frequently results in staining on curtains, wooden window casings, and hardwood floors, as well as contributing to the development of molds (Figures 5 and 6). This is an issue that is targeted frequently in Japanese window manufacturers promotional material.

According to an estimate by the U.S. Foreign Commercial Service, the total Japanese window market is approximately US\$4 billion (438.8 billion yen 109 yen/ US\$1). A majority of the residential windows are aluminum but wood and vinyl windows have been slowly gaining market share. The window market in Japan is dominated by the large aluminum manufacturers, most of whom are members of the major corporate groupings (*keiretsu*). Aluminum windows comprise approximately 90% of the Japanese residential window market. Aluminum windows have been used in Japan since 1932 and have been widely adopted because they are lightweight, sturdy, weather resistant, and were grandfathered into the building code as non-combustible. Vinyl windows are a distant second in Japan with a market share of approximately 8.5% while wood windows represent only about 1.5% of the window market.

The major manufacturers of Japanese aluminum windows are YKK, Tostem, Asahi Glass, and Fuji Sash. The dominant manufacturers of vinyl-clad windows are Tostem, Tokuyama, and Mitsui. The dominant type of window in Japan is the slider window, with a 52 percent share of the window market, although many other types of window styles are utilized, Figures 3 and 4. In 1996, the estimated size of the Japanese wood window market was US\$99 million (10.8 billion yen) while the market for vinyl windows was US\$320 million (34.9 billion yen). The combined wood and vinyl window market was US\$419 million (45.7 billion yen), a 31% increase over 1994

(USFCS 1998).

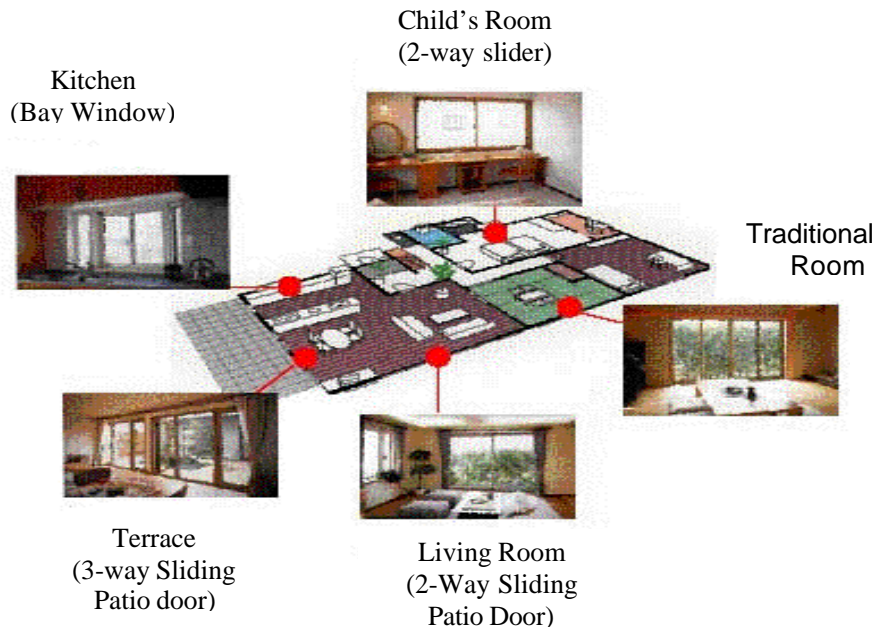
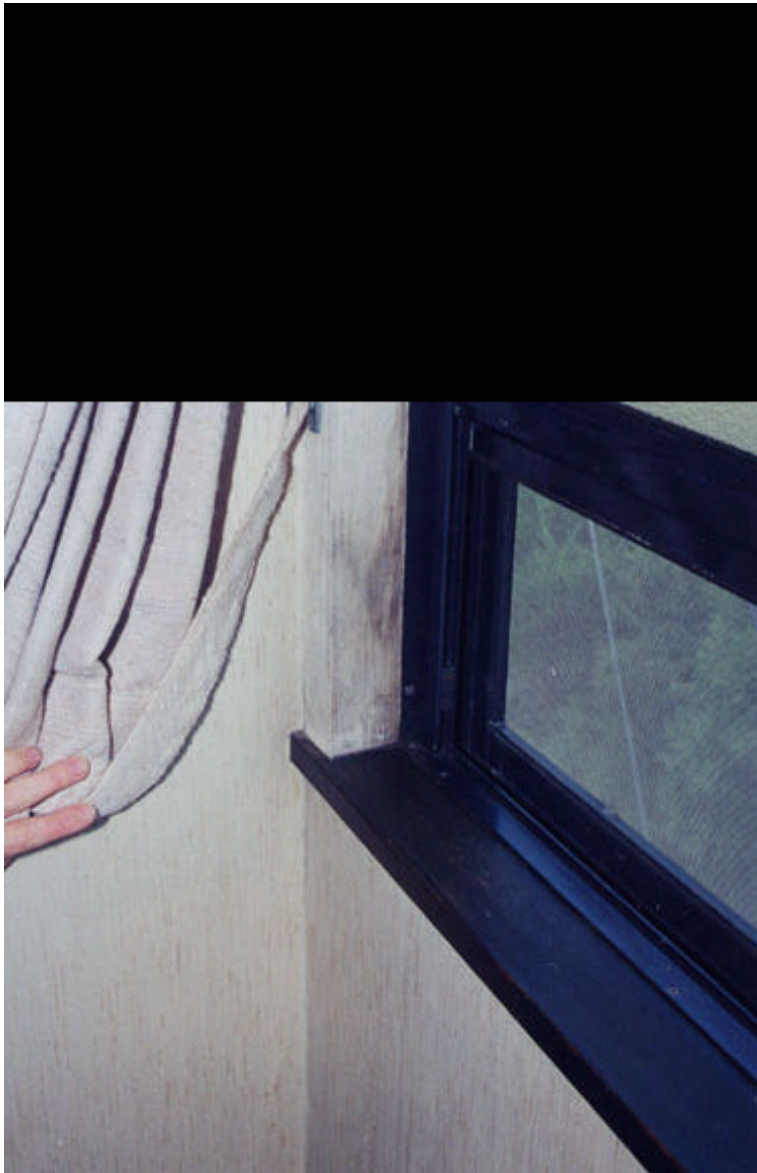

**Figure 3.** Typical layout of windows in a traditional Japanese home.



**Figure 4.** Types of windows commonly used in Japanese residential housing.

Source: Carmody, J. et. al., 2996.



**Figure 5.** Mold and staining is a common problem with aluminum windows in Japan.



**Figure 6.** Mold and staining is caused by condensation and water infiltration through aluminum windows.

The predominant type of window style installed in new residential homes in Japan is the horizontal slider, including both single and double sliders, Table 1. With a market share of over 50%, the horizontal slider is clearly the choice of builders. Other window styles that are popular include bay/bow windows, casement, and awning windows. While aluminum windows dominate the housing market, the interiors of almost 60% of aluminum slider windows are trimmed out with wood, Table 2. This clearly shows that while Japanese builders and homeowners favor aluminum for its perceived superior performance when exposed to the elements, they also prefer the appearance of wood windows on the interior of the house. The window data also suggests that vinyl windows have been successful in gaining a foothold in the casement and picture window segments of the window industry. Finally, the window data suggests that black window sashes are the most popular overall although Japanese-style windows still favor bronze colored sashes (Table 3).

**Table 1. Window types installed in new single-family houses, 1993-1997.**

	1993	1994	1995	1996	1997
Sliding	50.6%	50.6%	51.4%	51.6%	51.2%
Bay/Bow	9.7%	9.4%	9.3%	9.6%	9.8%
Japanese double	7.0%	6.2%	6.0%	5.5%	5.1%
Double	3.0%	3.0%	2.7%	2.0%	1.9%
Casement	n/a	n/a	n/a	n/a	9.7%
Awning	n/a	n/a	n/a	n/a	9.1%
Picture	n/a	n/a	n/a	n/a	6.0%
Double hung	n/a	n/a	n/a	n/a	4.6%
Other	29.8%	30.8%	30.5%	31.4%	2.6%

Source: Japan Sash Association, 1999.

**Table 2. Sash materials used for residential windows, 1997.**

	Aluminum	Vinyl	Wood	Clad wood
Exterior of double slider	87.5%	2.7%	0.2%	9.6%
Interior of double slider	20.6%	19.7%	58.8%	0.9%
Bay/bow	92.0%	2.3%	0.1%	5.6%
Picture	79.3%	12.2%	0.2%	8.3%
Casement	50.1%	35.5%	0.0%	8.3%
Awning	99.7%	0.2%	0.0%	0.0%
Double hung	94.6%	1.7%	0.1%	3.6%
Corner	93.4%	0.0%	4.0%	2.6%
Roof	79.8%	1.3%	4.3%	14.5%

Source: Japan Sash Association, 1999.

**Table 3. Sash colors used for residential windows, 1997.**

	<b>Black</b>	<b>Bronze</b>	<b>White</b>	<b>Grey</b>	<b>Other</b>
Total	65.4%	23.6%	6.8%	1.1%	3.1%
Japanese-style	31.7%	62.0%	2.3%	0.6%	3.4%
Western-style	71.0%	15.8%	8.8%	1.5%	2.9%
Japanese/Western	66.4%	24.1%	5.6%	0.7%	3.3%

Source: Japan Sash Association, 1999.

There were almost 800,000 detached homes built in Japan in 1999. Of these, approximately 20% were located in quasi fire zone areas that restrict the use of wood and vinyl windows. This means that there were almost 650,000 homes built in areas where there are no fire code regulations restricting the use of wood windows. If we were to estimate that there are between 15 and 20 window units installed in a home, the total number of the market for windows in the non-fire zone areas is between 10 and 13 million units. Since the market share for wood windows is 1.5%, the number of wood windows installed in 1999 was between 144,000 and 192,000, of which approximately 60% were imported (although some estimates of the market share for imported wood windows range as high as 81%). Traditionally, most manufacturers of wood windows have been small to medium size companies that serve a restricted geographic region. Production methods are generally costly and labor intensive, using expensive European hardware, and lacking production economies of scale.

A discussion with several members of the Japanese wood window industry provides an illustrative example of the role of price in the window market<sup>1</sup>. These experts estimate that the cost of a typical home located in the rural areas ranges from ¥20 million to ¥40 million. Assuming that there are 20 windows in each home, this means that the total cost of installing a set of basic Japanese aluminum windows is approximately ¥800,000 while the cost of installing a custom aluminum window (with insulated glass, low E and wood trim) would be between ¥1-1.2 million. Similarly, a set of basic Japanese vinyl windows would cost approximately about ¥1 million and a set of custom windows would be cost approximately ¥1.5 million. These same experts estimate that the cost of using US vinyl clad wood windows would run between ¥1.5 and ¥1.8 million. Finally, installing a set of Japanese wood windows is estimated to be between ¥2-3 million. Clearly, this comparison shows that US vinyl clad wood windows are at the high end of the price scale, although they are substantially less costly than Japanese wood windows.

### ***Product Features and Accessories***

As a result of the intense competition within the electronics industry, Japanese consumers have come to appreciate and expect a wide selection of product features and accessories in virtually all product categories. Whereas a decade ago most window manufacturers limited product options to sliding rain screens (shutters), the range of window options has changed and expanded considerably today. For example, sliding rain screens have largely been replaced by roll-up rain screens (Figure 5). The evolution of roll up rain screens highlights the continuing efforts of window manufacturers to offer new product options to consumers and differentiate their products from those of their competitors. The first generation of roll up rain screens were operated with manual hand cranks. The second generation of rain screens offered motor driven screens, while today's models can be operated by remote control.

The newest generation of windows offers rain screens with adjustable louvers (Figure 7). These rain screens not only provide security and protection from the rain (particularly during the typhoon season when driven rain can often cause a problem with moisture infiltration around window openings), but they also allow the homeowner to

---

<sup>1</sup> *It is important to remember that window prices vary widely based on style and product features. Therefore this paragraph is meant to be illustrative of relative price levels for similar types of windows, and should not be taken as a definitive comparison of specific window prices.*

regulate the level of natural lighting in the room. Learning from the US window industry, many Japanese window manufacturers now offer a wide variety of window coatings and tints as well as windows with different thermal and noise reduction performance characteristics. In summary, the larger window manufacturers are constantly looking to develop new product features that meet the needs of home buyers while providing them with an opportunity to differentiate their products from those of their competitors.

### ***Import Duties and Taxes***

There is no import duty applied to wood windows although there is a 4.3% duty imposed on vinyl window imports. The tariff rate imposed on house packages is 0.8%, and window imports are often included in house packages to avoid the import tariffs. Additionally, there is a 5% consumption tax that is applied on all imports, as well as domestic products (JETRO 1997a).

### ***Industrial Standardization Law***

The Japanese Industrial Standard (JIS) for sashes (A4706) was revised in 1996 to incorporate international standards with the domestic standards and move from a specification-based standard to a performance-based standard. The Japanese government defines the categories of sashes and performance features they must comply with, including opening and closing force, wind-pressure resistance, air tightness, water tightness, and insulation values. It also establishes grade levels based on these performance characteristics. JIS approval is obtained by having each production facility inspected to assure their ability to consistently manufacture products that comply with JIS standards. Products from approved facilities may display the JIS mark. Foreign factories may also qualify as a JIS approved production facility (JETRO 1997a).



**Figure 7. Retractable window screens have become commonplace in new home construction.**

### ***Quality of Housing Component Certification System***

The Ministry of Construction has established a certification system called the “Quality Housing Component Certification System”. Certified products have demonstrated superior characteristics in terms of product quality, performance, price, and after sales service. Certification is conducted by the Center For Better Living and products that have received this certification may display the “BL” product certification logo. In addition to quality certification, companies that are Better Living certified may participate in Better Living’s insurance program which provides warranty and indemnification insurance (JETRO 1997a).

### ***New Energy Savings Standards***

The Japanese government has programs to reduce Japan’s dependence on energy and this includes incentives to encourage energy efficient homes. In 1992, energy savings standards for new houses were strengthened. This revision included 3 main points: 1) Japan was divided into 6 regions (Figure 8), energy saving standards were set for each region (Table 4), and heat loss coefficients that measure insulation values also became more stringent, 2) air tightness housing standards were created for northern Japan, and 3) sunlight retention coefficients were established for summer cooling loads in southern Japan.

Manufacturers and home builders have used public financing as a tool to promote the acceptance of these standards. New housing that complies with these standards qualifies for higher levels of financing from the Government Housing Loan Corporation (JETRO 1997a). These programs provide an excellent opportunity for wood and vinyl window manufacturers to increase their share of the Japanese window market. For example, the Japanese Government Housing Loan Corporation offers subsidized interest rates for homes that include energy efficient products such as wood and vinyl insulated windows.

### ***The Government Housing Loan Corporation (GHLC) New Finance Program***

GHLC has established an incentive program for new homes that comply with the new standards for energy saving, barrier free design, and durability. Dwellings that qualify become eligible for higher levels of mortgage financing. These standards have been summarized by JETRO as follows:

1. *Energy Savings Dwellings* - These are dwellings that are insulated to meet the energy efficiency levels defined by the law for the Rationalization of Energy Consumption.
2. *Barrier Free Dwellings* – These are dwellings that incorporate user-friendly features for senior citizens. These include the elimination of changes in floor level, the installation of handrails on stairs, tracks for sliding glass doors that are flush with the floor, and other features defined by the barrier-free standards defined by the Japanese government.
3. *Durable Dwellings* – These are single-family dwellings that are built to be more sturdy and durable as defined by the durability standards established by the Japanese government. These include stronger foundations, thicker beams, and other structural supports, and other measures defined by the Japanese government. The primary purpose of this standard is to provide housing that is more resistant to earthquakes.



**Figure 8. Regional energy classification system used in Japan.**  
Source: JETRO

**Table 4. Table of Japan Energy Standards, by region.**

Region	Type of Fixture and Combination (equivalent of one or another)
I	<ul style="list-style-type: none"> <li>Fixtures of triple structure with a single pane of glass</li> <li>Fixtures of double structure with a single pane of glass and a pane of multi-layer glass made from low-emission glass (limited to those with an air layer of 12 mm or greater)</li> <li>Fixture of double structure with a single pane of glass and a pane of multi-layer glass (limited to those with an air layer of 12 mm or greater), at least one pane of which has a fixture made from wood, plastic, or material with equal or greater insulating properties</li> <li>Airtight fixtures made from wood with triple glass pane (limited to those with an air layer of 12 mm or greater), with airtight fixture made from wood, plastic, or material with equal or greater insulating properties</li> <li>Fixtures with multi-layer glass pane made from low-emission glass (limited to those with an air layer of 12 mm or greater), with airtight fixture made from wood, plastic, or material with equal or greater insulating properties.</li> </ul>
II	<ul style="list-style-type: none"> <li>Fixtures of double structure, at least one pane of which has a fixture made of wood, plastic, or material with equal or greater insulating properties, or has a metal fixture the frame of which is connected to elastic PVC or other material of equal or greater insulating properties, having a thickness of at least 3 mm and a width of no more than 10mm.</li> <li>Fixture with multi-layer glass (limited to those with an air layer of 6 mm or greater between panes), with an airtight fixture made of wood, plastic, or other material of equal or greater insulating properties</li> <li>Fixtures of double structure consisting of a single pane of glass and a pane of multi-layer glass</li> </ul>
III	<ul style="list-style-type: none"> <li>Fixtures of double structure with a single pane of glass</li> <li>Fixtures with a pane of multi-layer glass</li> </ul>
IV	
V	<ul style="list-style-type: none"> <li>Fixtures with a single pane of glass</li> </ul>
VI	

Source: JETRO

## *Distribution and Marketing Strategies*

The distribution channel used for Japanese wood windows is not particularly complex or extended, as is the case in other sectors of the Japanese economy. However, the distribution of wood windows without glass panes in Japan runs counter to the single most important strength of the US window industry – providing a completed unit with high energy efficiency. The distribution of windows in Japan involves a number of different entities including manufacturers, primary wholesaler, secondary wholesaler(s), retailers, and home builders. These distribution members perform a variety of functions, including production, parts inventory, credit, installation, and technical service. Distribution can generally be divided into two main channels; the wholesaler/dealer channel and the direct sales channel. Most manufacturers utilize both channels. The wholesaler/dealer channel accounts for approximately 75% of all window sales although direct sales from the manufacturer to the builder are increasing. For the wholesaler/dealer channel, the manufacturer ships the window without the glass installed. The glass pane is then inserted by the dealer or retailer prior to being shipped to the job site. A report issued by JETRO (1998) provides an interesting description of the roles of the various channel intermediaries for windows in Japan.

### 1. Window Manufacturers

There are two consistent trends among the major window manufacturers, including the addition of wooden windows to their product lines and the expansion of direct distribution channels. Pricing is listed in pricing catalogues that are distributed to dealers, retailers, home builders, housing manufacturers and architectural design offices. Each entity that receives a pricing catalogue also receives a discount factor. For example, the normal discount factor for dealers is 65%-70% of the list price. Window manufacturers are often required to provide their customers with credit terms.

### 2. Primary Wholesalers

Primary wholesalers provide manufacturers with national distribution for their products. Besides distributing windows and parts to secondary wholesalers and retailers, primary wholesalers often provide their customers with credit terms.

### 3. Secondary Wholesalers

Secondary wholesalers receive windows and parts from primary wholesalers and sell them to retailers and builders within a specific geographic region. There are a wide variety of types of secondary wholesalers including building materials wholesalers, glass wholesalers, fixture wholesalers, lumber wholesalers, and hardware wholesalers. Similar to primary wholesalers, secondary wholesalers provide financing for the customers.

### 4. Retailers/Dealers

There are approximately 30,000 window and sash retailers in Japan. The retailers put together the sashes, insert glass panes, and deliver them to the job site. The retailers also deliver paper screens (“Shoji” which are used as a decorative item on the inside of the window), window screens, door hardware, and other items at the appropriate time in the job scheduling process. Sash assembly methods are different depending on the manufacturer and so most retailers specialize in one manufacturer’s line of products. However, other products are also carried to meet the demands of home builder customers.

In the past, dealers have carried large inventories of windows. However, recently manufacturers have improved their “made to order” capability and physical distribution and so there has been a shift towards “just in time” inventory. This increased efficiency has been partially responsible for the increase in manufacturers distributing directly to retailers and builders. However, dealers remain an important component of the window distribution channel.

#### 4. Home Builders

Traditionally, in Japan it has been very rare for the home buyer to specify a particular brand of window. It is usually the home builder who chooses the type and brand of window, considering a variety of factors, including the ease of installation, product cost, and window quality in the window specification process. Japanese contractors now, more than in the past, are choosing manufacturers based on the breadth of the product line offerings, product quality, and technical characteristics. Additionally, with the shift to higher value added features such as insulated glass and roll-up screens, home buyers are now beginning to specify window products more frequently.

##### ***Financing***

*Tegata* (credit) is often provided by the manufacturer to the primary wholesaler for a 90-120 day period. The primary wholesaler then typically provides credit terms to secondary wholesalers on a 60 day basis while secondary wholesalers will provide 30 day credit to home builders. *Tegata* are often structured so that the customer pays 50% in cash and receives credit terms for an additional 50% of the price. The wholesale markup within the distribution channel is approximately 40-50%. *Tegata* are often sold by the holder to their bank at a 2.3% discount. Since there is usually no interest on *tegata* (essentially an interest free loan), this system often puts US windows at a competitive disadvantage relative to domestic windows.

##### ***Warranties***

Window manufacturers are required to provide at least a two year warranty with the provisions explicitly stated in the printed warranty. Since many large home builders offer a 10 year warranty with their homes, window manufacturers often extend their warranty coverage to coincide with home builder warranties. Parts inventory are generally maintained for a period of ten years after a specific window model has been discontinued.

## OVERVIEW OF MAJOR JAPANESE WINDOW MANUFACTURERS

The top five Japanese residential window companies in 1998 were Tostem Corporation (34.3% market share), YKK Architectural Products In. (30.7%), Sankyo Aluminum Industry Co. (11.2%), Shin Nikkei Company (10.8%), and Tateyama Aluminum Industry Company (7.2%). The Japanese window industry is very consolidated with the top two companies controlling 65% of the market. All of these companies have reacted to competition from North American manufacturers by developing higher quality, higher performance products. In order to understand the broad range of products, product features, and service being offered in Japan, a brief overview of each company is provided below.

### Tostem

Tostem, established in 1949, has 10,433 employees and annual sales of approximately US\$5.2 billion (121Yen/US\$1). The company has 48 factories in Japan, 450 related sales and technical service offices, and 30 showrooms. Their products include residential and commercial windows, doors, exterior wall panels, system kitchens and baths, and a variety of other products. Tostem also offers a CAD integration program to integrate their products into the CAD programs used by architects.

Bundling products is a popular method of marketing building materials in Japan and Tostem uses this method through their system kitchen and system bathroom packages. A “system” is a group of products bundled together to make an integrated bathroom or kitchen. For example, a system kitchen might include a sink, faucet, countertop, cabinets, hood range, and bay window. With its 30 showrooms, Tostem goes beyond selling products to offering their customers interior coordination. They offer a variety of system kitchens and bathrooms. One market Tostem is targeting with these showrooms is the remodel market. In 1996, 45% of all home loans from the Japanese Government Housing Loan Corporation were for remodels. Tostem has recently been opening new showrooms to go after the remodel market.

Another area Tostem is targeting is the growing elderly segment of the population. By the year 2020, almost 25% of Japan’s population will be over the age of 65. Tostem has a line of products called “barrier free” which are designed to be user-friendly for senior citizens. The designs include windows and patio doors with larger handles for easier gripping, wider door openings, tracks that are flush with the floor to avoid stumbling, and windows and doors that slide easier, requiring less force to operate.

Tostem has several different window lines including an insulated series, a sound-proof series, an electrically operated weather screen series (with an optional remote control), a fire barrier series, and other specialized systems. Within each of these series there are several different product options offered. Tostem’s insulated window series includes four different products, including an aluminum window with insulated glass (the Thermal brand), an aluminum clad wood window (the Decorte), a vinyl window (the Maister), and an aluminum clad vinyl window (the Fonbraus).

Similar to all major window manufacturers in Japan, Tostem offers a broad array of window accessories, including security screens and rain screens, and louvered screens. These accessories are available in a range of colors and often come with such innovative options as remote control, motor driven openers, and keyless locking systems, Figures 9-11.



**Figure 9. Manual or remote controlled weather screens provide privacy and protection from the elements and intruders.**  
Source: Tostem website.



**Figure 10. Aluminum clad wood casement window from the Decorte window line.**  
Source: Tostem website.



**Figure 11. Japanese manufacturers provide builders and homeowners with a wide range of product features and options. The weather screen in this figure has 12 combinations of cap design and screen colors, in addition to a power driven option and remote control.**

Source: Tostem website.

YKK Architectural Products Inc.

YKK, established in 1957, has 10,855 employees and annual sales of approximately US\$5.3 billion (121Yen/US\$1). YKK is globally orientated with YKK offices located in 48 countries. Within Japan, the company has 9 branch offices, 47 sales offices, 16 factories and two installation centers. YKK services both the residential and commercial construction markets. Residential products include windows, doors, siding, shutters, fans, balconies, car ports, system kitchens and baths, and other products. YKK also offers software that allows their products to be integrated with CAD design software.

YKK also has 12 product showrooms to display their system kitchens and bathrooms, windows, and other residential products. YKK has a broad variety of window products. Like Tostem, YKK has four main products within their insulated window series, including an aluminum window with insulated glass (the Telemor line), a vinyl window with insulated glass (the Promade III), an aluminum clad vinyl window (the Alpad), and an aluminum clad wood window (the Renard). In addition to their thermal product series, YKK also has a line of “barrier free” products target to the senior market, Figures 12-15.



Figure 12. Product literature highlights the thermal and soundproofing characteristics of YKK windows.

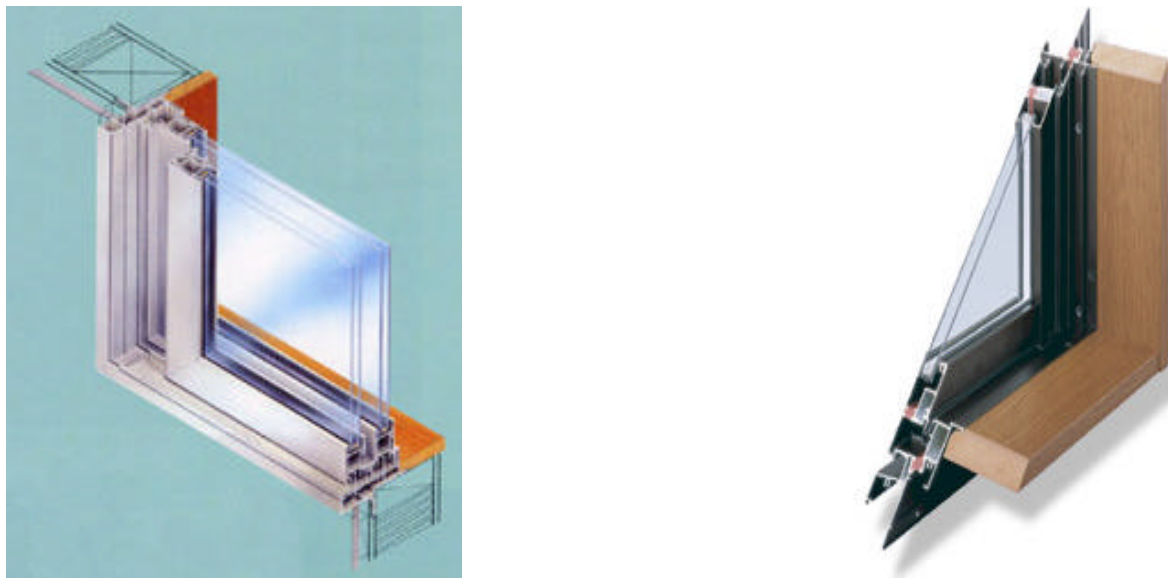

Figure 13. Corner details of YKK aluminum clad wood windows.  
Source: YKK website



**Figure 14. Low profile weather screen on a double slider aluminum clad wood window.**  
Source: YKK website.



**Figure 15. A combination weather screen with louvers, this window combines both security and natural lighting attributes.**  
Source: YKK website.

Sankyo Aluminum Industry Co.

Sankyo, established in 1960, has 6005 employees and annual sales of approximately US\$2.1 billion (121Yen/US\$1). Its product line includes doors, windows, system kitchens, system baths, commercial construction products, and other building products. The company has 6 factories and has established distribution outlets within every prefecture of Japan.

Sankyo markets their products through company owned distribution outlets. They offer CAD integration through a software program called Mr. Planner. They also have a number of showrooms to promote their residential products, including windows, system kitchens, system baths, and other products. Sankyo also targets the senior citizen market segment through a line of “barrier free” products.

Sankyo has two products within their insulated window series the “Sunshadan” and the “Noista” product lines. The first is a vinyl/ aluminum combination window line that uses vinyl strips on the interior of the window (the Sunshadan product line). The product literature for the Sunshadan window line emphasizes its superior insulation performance, anti-moisture accumulation ability, and sound proofing capability. Sankyo’s second insulated window line (the Noista), is an aluminum window with insulated glass. Like the other major window manufacturers, Sankyo has developed a line of windows specifically designed for replacement applications, Figure 16.



**Figure 16. Product advertisement targeting the remodel market.**

Source: Sankyo website.

Shin Nikkei Corporation

Shin Nikkei, established in 1977 has 4478 employees and annual sales of approximately US\$1.9 billion (121Yen/US\$1). They have 7 factories and 25 branch offices. Their products include commercial and residential windows, doors, rain gutters, car ports, and other interior and exterior building products.

Compared with Tostem and YKK, Shin Nikkei has a limited variety of window products. In addition to their regular line of aluminum windows with insulated glass, they also have a newly developed aluminum clad vinyl window line called the Arupura 70. Their most recent product line features wood trim in the interior, Figures 17 and 18).

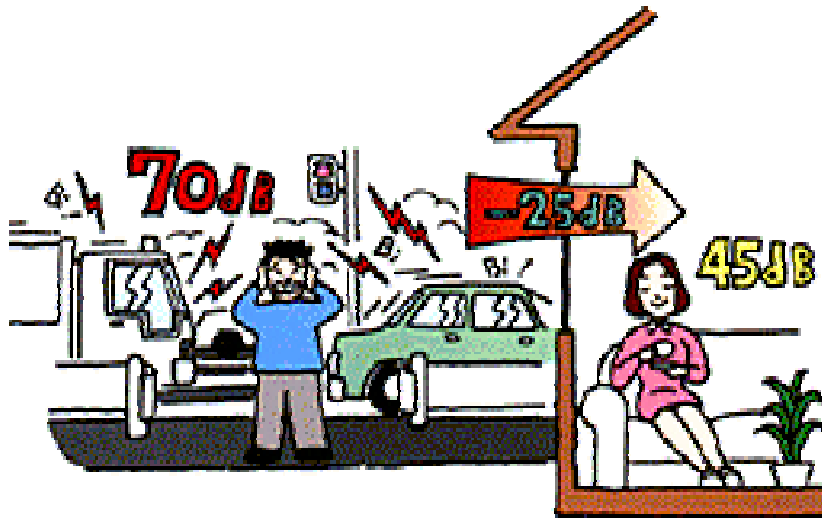

**Figure 17.** The soundproofing qualities of Shin Nikkei windows are emphasized.

Source: Shin Nikkei website.

# Clearbirch

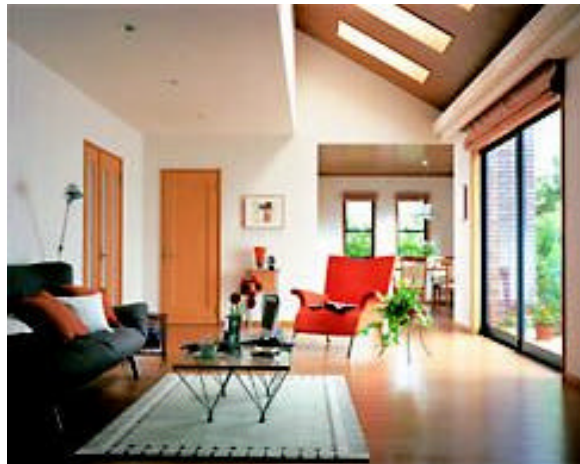

**Figure 18.** The Clearbirch product line includes aluminum clad wood windows and doors.

Source: Shin Nikkei website.

Tateyama Aluminum Industry Corporation

Tateyama, established in 1948, has 3357 employees and annual sales of approximately US\$1.3 billion (121Yen/ US\$1). They have 5 factories, 18 branch offices, 18 distribution warehouse centers, and 49 distributors. Their products include residential and commercial windows, doors, outdoor products (i.e. decorative garden, etc), system kitchens, and system bathrooms.

Tateyama's insulation series includes an aluminum window with insulated glass and an aluminum clad vinyl window called the Apex. The Apex window line is advertised as having superior insulation, sound proofing, and anti-moisture build up capability. The anti-moisture build up capability of this line of windows is heavily emphasized in their product advertising. The product literature highlights the anti-moisture performance of the Apex window by emphasizing its effectiveness in reducing moisture buildup on the interior of the window which creates mold and mildew, dirties curtains, and can ruin "shoji's" or the traditional Japanese paper sliding door with a wood frame. The literature points out that "Apex" has 12 mm of insulated glass which effectively resists moisture build up (Figures 19 and 20).



**Figure 19. Double slider aluminum clad vinyl window with side weather screens.**

Source: Tateyama website.



Figure 20. Promotional flyer highlighting the range of window styles and window accessories offered by Tateyama.  
 Source: Tateyama website.

### *Characteristics of the Japanese wood window industry*

Japanese wood window manufacturers are generally small firms serving a regional niche market. Most of these firms utilize relatively modest technology to produce a limited product line that is marketed towards a high quality, niche market. This niche market is characterized by home buyers who are willing to pay a premium price for a high quality, high performance custom wood window. These customers are often looking for a high performance wood window that incorporates custom features like expensive European tilt-and-turn hardware and fire resistant construction. Given their focus on the high quality niche market, it is no surprise that Japanese wooden window manufacturers offer comprehensive service policies for their products, including technical support (for both installation and maintenance), parts, and extended product warranties.

Most wooden window manufacturers in Japan employ a combination of basic processing technology and labor intensive manufacturing techniques to produce a high cost, high quality window, Figures 21-26. Window sashes are often manufactured from composite lumber (Figure 22) incorporating straight grained lumber with narrow growth rings from which all defects have been removed. The laminated member is then covered with a very high quality veneer overlay to produce an aesthetically pleasing, structurally stable window component. Japanese wood windows are manufactured in an extremely wide variety of sizes and window manufacturers pride themselves on their ability to produce custom windows for virtually any size of window opening, Figure 23. The production and finishing processes employed in most wood window companies is highly labor intensive compared to the US, Figures 24-26. The inevitable impact of low levels of automation, high levels of product customization, and labor intensive manufacturing techniques is that Japanese wooden windows are very expensive, costing almost three times more than a similar style of aluminum window.

The modern wood window industry in Japan is relatively new and struggling to find its place in the window market. Regulatory changes that favor energy efficiency and soundproofing ability in windows may help the wood window industry expand their market presence. The Japan Wood Window Association, affiliated with the Japan Housing and Wood Technology Center (HOWTEC), was recently established to help in the promotion of wood windows within the residential construction industry. Currently, the association has 16 wood window manufacturers in its membership. These manufacturers are listed in the Appendices.



**Figure 21.** A small wooden window manufacturer located in Chino City, Nagano prefecture.

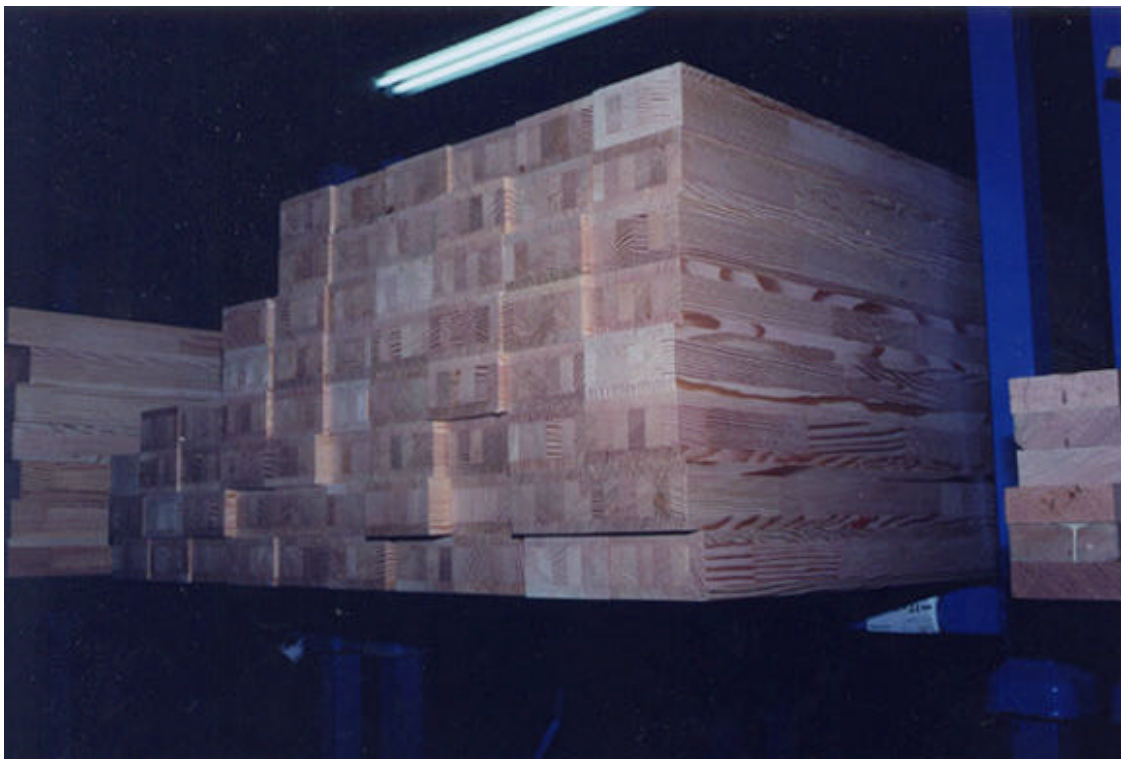

**Figure 22.** A stack of composite lumber that will be processed into window components.



**Figure 23.** Japanese window manufacturers produce a wide range of stock and custom window sizes.



**Figure 24.** Worker installing a glass pane in a window.



**Figure 25.** Window blanks are manually cut to size for assembly.



**Figure 26.** Workers manually apply a primer/sealer onto wooden window components.

## US EXPORTS OF WOODEN BUILDING MATERIALS TO JAPAN

Despite their extensive forest resource and wood processing industry, Japan has long relied on imports to provide the majority of their raw material requirements. The US has long been an important supplier of primary wood products and has been increasingly promoting exports of secondary wood products to Japan. However, as a variety of factors have worked to reduce the competitiveness of US wood products in Japan, other countries have increased their presence in Japan at the expense of US products.

The vast majority of wood product exports from the US to Japan have traditionally been in the form of unprocessed wood products, primarily softwood logs, softwood lumber, and chips. While primary products stabilized at about \$3 billion during the period 1993-1996, secondary wood products exports to Japan increased by 192%, accounting for virtually all export growth during this period, Figure 27. As a result, the ratio of secondary wood products to primary wood products increased substantially from just 4.3% to 12.8%. The Asian economic crisis in 1997 and the ongoing weakness of the Japanese economy have taken a heavy toll on US wood products exports to Japan. During the period 1996-1999, primary wood products exports to Japan declined by 53% while secondary wood products declined by 46%. Given the steeper drop in primary exports, the ratio of secondary wood product exports to primary wood products exports actually increased to 14.6% in 1999. Note that this increase is a reflection of the fact that, despite the recent decline in exports to Japan, secondary wood products exports show an 85% increase over the period 1989-1999, while primary wood product exports declines by almost 43% over the same period. Clearly, the ongoing economic recession in Japan has had a much more adverse impact on primary wood product exports from the US.

Japanese imports of wooden doors, windows, *tategu*, and transoms have all declined substantially since 1997, although the trends can be attributed to different reasons, Figure 28. But first, some definitions. *Tategu* are the interior wood trim components used with shoji screens that are installed in the traditional *tatami* room. The term *tategu* is used to refer to a variety of window casing parts including the *shiiki* (bottom track) and *kamoi* (top track) in which the shoji screen slides. Transoms (called *rama* in Japan) are intricately carved panels that are installed above the *fusuma* (essentially a *shoji* door used only in traditional *tatami* rooms), which allow air flow, even when the *fusuma* is closed, Figures 29 and 30. The Japanese trade statistics indicate that imports of both *tategu* and *rama* (transoms) have been declining since 1989. This trend can be attributed to the fact that many younger home buyers are not willing to pay the high cost associated with including a *tatami* room in a new house. In contrast, imports of both windows and doors increased substantially up until the Asian crisis.

US exports of wooden doors and windows display surprisingly different trends over the period 1989-2000, Figure 31. Export performance for both products was relatively stable during the period 1989-1993, followed by substantial export growth from 1993-1996. Exports of wooden doors surged from \$3.4million to \$47.1 million while wood window exports jumped from \$5.7 million to \$21.9 million by 1996. However, whereas wood window exports have dropped to \$19.6 million in 2000 (a 10.7% drop), wooden door exports plummeted to \$14.9 million (a 68.4% drop).

Prior to the Asian crisis, US market share for windows had remained fairly constant at approximately 60%, Figure 32. However, in 1999 market share declined substantially to 52%. Over the period, 1990-1999, the Canadian share of the wood window market jumped from 3.9% to 16.8% while the EU market share declined from 30.1% to 25.1%. Interestingly, the Swedish market share increased from 5.8% to 8.3% while the Danish share fell sharply from 22.6% to 11.8%.



**Figure 27. US primary and secondary wood products exports to Japan, 1989-1999.**  
Source: USDOC.

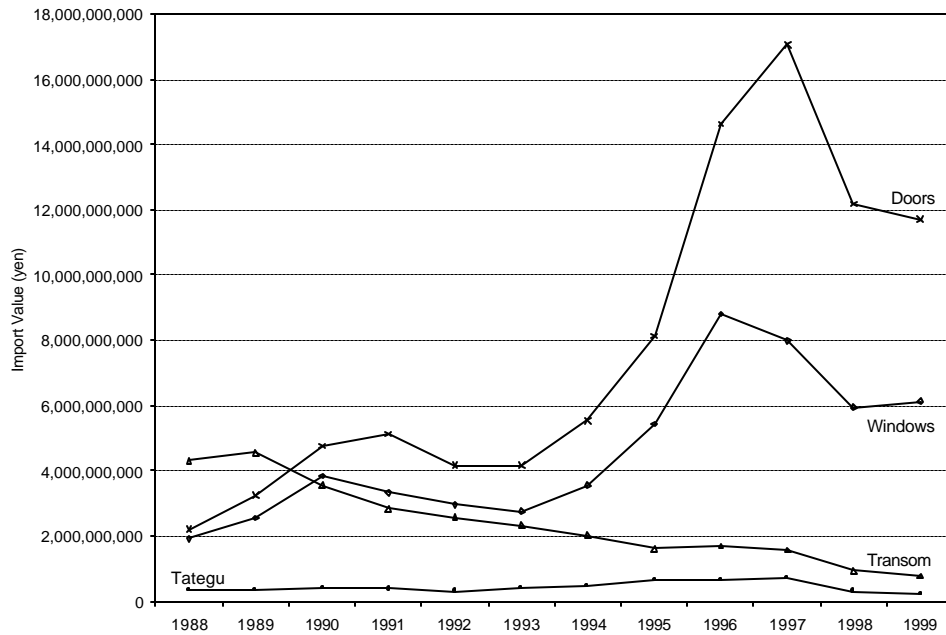

**Figure 28. Japanese imports of wooden windows, doors, tategu, and transoms, 1989-1999.**  
Source: Japan Tariff Association.



**Figure 29.** Shoji door ready for shipping. A paper face and back will be applied by another company prior to being installed.



**Figure 30.** Intricately carved panels (called rama) are often installed above shoji doors in traditional tatami rooms.

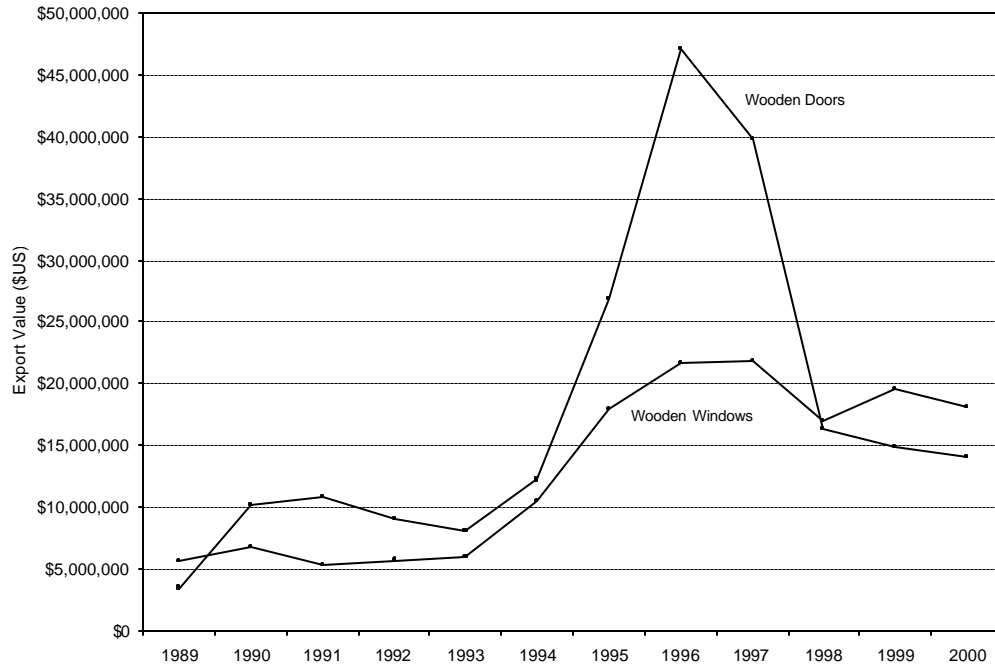

**Figure 31. US exports of wooden doors and windows to Japan, 1989-2000.**  
Source: USDOC.

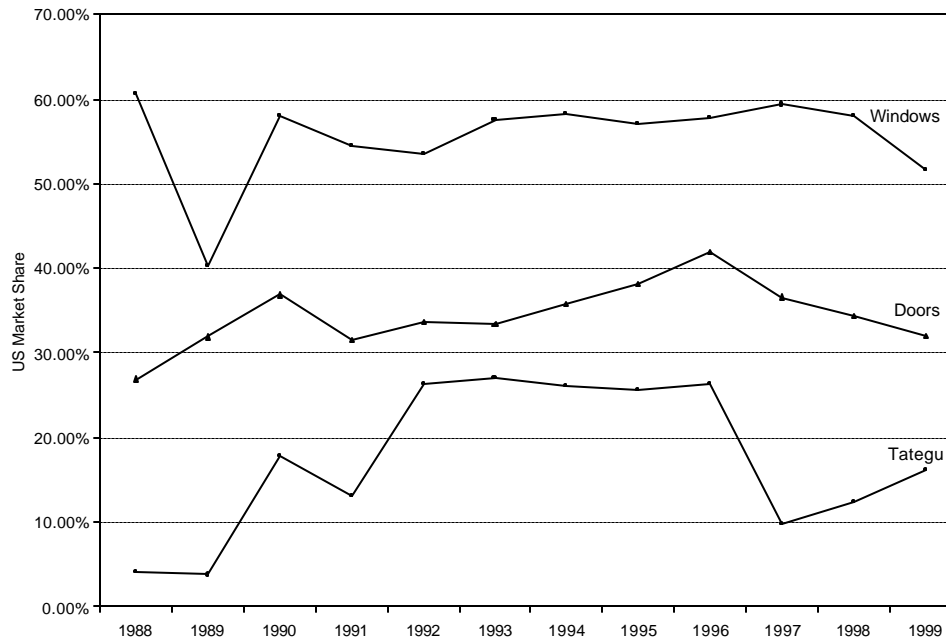

**Figure 32. US share of Japanese wood window, door and tategu imports, 1988-1999.**  
Source: Japan Tariff Association.

The difference in export performance for wooden doors and windows can be attributed largely to the increasing price sensitivity of Japanese builders and the level of technology required for each product type. For example, Japanese door manufacturers have been successful in investing in production facilities in countries where raw material and labor costs are low and environmental regulations are few. Window manufacturing technology, in contrast, is comparatively more sophisticated and Japanese window manufacturers (who largely focus on aluminum and vinyl window products) continue to employ domestic production facilities. Obviously, the implications are that US wooden door manufacturers find themselves competing against lower cost producers in southeast Asia while wood window manufacturers are competing against domestically produced aluminum and vinyl windows. As a result, US wooden window manufacturers find themselves competing in a relatively small niche market where they have a competitive advantage against their Japanese competitors.



## CONSTRAINTS AND OPPORTUNITIES FOR US WOODEN WINDOWS IN JAPAN

### HISTORICAL WINDOW DESIGNS

Historically, Japanese wood windows were based on a design of wood frames and paper *shoji* screens. Traditionally, many Japanese have viewed the outside as an extension of the interior of the house, and these types of windows and doors were an integral part of the effort to reduce the barriers between the outside and inside environments. This window design has greatly influenced the Japanese preference for double slider windows and doors.

Prior to 1960, locally manufactured wood windows were widely available and commonly used throughout Japan. However, these windows were poor quality and had serious problems with dimensional stability, water infiltration, durability, noise reduction, air infiltration, and thermal efficiency, Figures 33-35. In addition, the wood windows were usually made by a window manufacturer while the window sash and sliding tracks for the *shoji* were generally fabricated on-site by a wooden fittings specialist (*tateguya*) who crafted each door and window to fit the individual size of each door and window opening (which were generally not standardized). Thus, each door and window was essentially a custom size and, as a result, there was often a poor fit between the window and sash, adversely affecting the thermal efficiency and noise reduction performance of windows and doors, as well as their ability to resist air and water infiltration. Interestingly, the poor weather tightness of older Japanese wood windows meant that they were not subject to moisture buildup on the interior of the window pane as the next generation of weathertight aluminum windows would prove to be.

Obviously, these problems contributed to the poor perception of wood windows and provided a market opportunity for aluminum manufacturers in Japan. When aluminum windows were introduced into the market in the 1950's, they achieved rapid market success because of their effectiveness in providing protection against the elements. While the quality of wooden windows has improved dramatically in recent years, these quality improvements have been accompanied by significantly higher prices. As a result, the price of a wooden window is approximately 3 times higher than a similar aluminum window in Japan. Aluminum windows now dominate residential construction (both single family and multi-family) with a market share of approximately 90 percent as compared to 8.5 percent for vinyl and 1.5 percent for wood. The adoption of aluminum windows has also been favored by the fire regulations and group application process for fire code approval awarded by the then Ministry of Construction (now the Ministry of Land, Infrastructure, and Transportation (MLIT)).



**Figure 33. Traditional wood windows were often poor quality and poorly maintained.**



**Figure 34. Poor quality windows and construction practices contributed to moisture infiltration around and through wood windows.**



**Figure 35. While traditional window designs were interesting poor quality adversely affected performance in Japan's hot, humid and wet climate.**

Recently, builders, consumers and industry experts are increasingly recognizing the inherent limitations of aluminum windows in the following areas:

- poor fire resistance
- poor thermal efficiency
- poor soundproofing characteristics
- condensation buildup on interior window surfaces
- formation of mold and corrosion on interior window frame components
- poor air infiltration performance (due largely to product attributes such as weep holes and double sliding window design)

#### **FIRE SAFETY REGULATIONS AND FIRE ZONES**

Japan fire safety regulations fall under the Ministry of Land, Infrastructure, and Transportation (MLIT) and are specified within the Building Standards Law (BSL), Appendix B. These regulations were summarized in a report by the U.S. Foreign Commercial Service. Japan fire regulations are divided into fire protection districts (fire zones), semi-fire protection districts (quasi fire zones), and regular non-protected districts (non fire zones). Fire zones include most of Japan's urban areas while quasi fire zones include most of Japan's suburban areas.

Wood and vinyl windows do not need to comply with fire safety regulations if they are used in non fire zones. However, for installation within fire zones and quasi fire zones, they must comply with the fire safety regulations. These regulations are based on exterior “portions liable to catch fire”. These “portions” are defined as three specified areas: the boundary line with the adjacent land lot, the center line of a road, and the center line between external walls of adjacent buildings on the same site. Windows must be installed 3 meters or more for the first floor and 5 meters or more for the second floor from the specified areas described in the previous sentence. Due to these regulations, most wood and vinyl windows may not be used in urban and suburban areas. Since these regulations were passed in 1991, 39 Japanese wood windows have received fire protection approval. Japanese window companies have managed to circumvent the fire regulations by producing aluminum clad vinyl windows (these are essentially a vinyl window with an aluminum exterior cladding), (JETRO 1998).

### **Fire regulations for wooden windows**

Although there are many ways to classify residential housing in Japan, all houses must meet the requirements of the Building Standards Law (JETRO 1993). These building codes cover all aspects of the construction industry in Japan. The BSL ensures that the building site and structure are built in a manner that does not endanger the occupant’s life, health, and property from preventable disasters. All housing must also meet the strict fire prevention and flammability guidelines of the Fire Laws. Fire prevention requirements are strict because of a history of devastating fires in Japan’s residential areas. Major fires burned down many houses during the 1923 Great Kanto Earthquake in Tokyo and the 1995 Hanshin Earthquake in Kobe. Fires in urban areas have historically caused many fatalities and, in response, the Japanese government implemented strict guidelines regarding the construction of fire-resistant houses to prevent the spread of fire to adjacent buildings. In addition, residential lots in urban areas are small in size and the footprint of a house usually covers 80%-90% of the lot, resulting in houses being very close together, a factor that contributes to the necessity for fire resistant housing.

A history of devastating fires resulting from a combination of high density housing, the frequent occurrence of earthquakes and typhoons, the extensive use of wood as a building material, and poor quality construction led the Japanese government to include strict and specific fire regulations in the Building Standards Law (BSL). The objectives of these fire regulations are to contain the fire within a single structure and prevent the fire from spreading to adjacent structures.

Articles 64, 109, and 110 of the BSL specify where “fire doors” must be used. It is important to note that within the context of the BSL the term “fire door” refers to all openings in the exterior of the structure, including windows. These fire regulations apply to all housing units built in fire and quasi-fire zones. In both of these areas, the BSL specifies what types of exterior building materials may, and may not, be used. There are two classes of fire doors in Japan, Class A and Class B:

- Class A fire doors require a 60 minute fire rating (*koshu*) and are generally specified for large multi-unit apartment buildings located in fire zones.
- Class B fire doors require a 20 minute fire rating (*otsu*) and are generally permitted to be used in single family detached homes and smaller, multi unit apartments located in the quasi-fire zones.

Having said this, there are some situations where fire rated windows and doors are not specified for single family homes located in quasi-fire zones. These situations occur when one or more of the following criteria can be met:

- when the doors and windows installed on the first floor are located 3 meters or more from the adjacent lot line or the center of the road
- when the doors and windows installed on the second (or higher) floor are located 5 meters or more from the adjacent lot line or the center of the road.

There are two types of methods for getting wooden windows approved as fire rated: the group approval process

(*tsusoku*) or the individual product approval process, Appendix C. Under the group approval process, a group of window manufacturers can apply to MOC to gain a fire rating for wood windows with the objective of establishing standardized product specifications as prepared by the applicant group. Gaining MOC approval would allow member companies to manufacture wooden windows within a specified range of product design variations. In contrast, the individual product approval process allows individual window manufacturers to gain approval for their own windows. The advantage of the group approval process is that it allows the member firms to spread the cost of the approval process across each firm. The disadvantage is that it requires that each firm conform to the product design criteria used in gaining fire approval, reducing their ability to develop new window designs or differentiate their products. To date, there has been just one North American aluminum-clad wood patio door that has received a fire rating, as well as one window manufacturer who has received a fire rating for a high performance custom wood window. However, approximately 39 Japanese wooden windows have received a fire rating, Appendix D. In the absence of a fire rated North American wooden or clad windows receiving fire rating approval, it is expected that the product specifications designated for the group approval system are likely to be based on the design specifications of the fire rated Japanese wood windows.

Aluminum windows were awarded a group approval system early on by MOC and the aluminum windows of member companies need to be tested only once as long as they conform to the product specifications. The MOC has delegated responsibility to conducting fire tests and awarding fire ratings to the Aluminum Fire Door Certification Council (associated with and housed within the Japan Sash Association). The Aluminum Fire Door Certification Council is permitted to certify aluminum windows under a group approval system that relies on long-standing performance data. This favorable system for aluminum windows has helped maintain the dominant market position of aluminum windows and this group is working to gain approval for aluminum clad windows manufactured by its member companies. As of 1999, US wood and aluminum clad window manufacturers can apply to have their windows tested under the group approval process. This process is not only time consuming, but also expensive.

#### **Fire tests for wooden windows**

The fire test is conducted in a furnace unit with the test window being installed in a non-flammable wall system, Appendix C. The furnace is then heated to 800C following the ISO heating temperature curve for window tests. The time of the window test is 30 minutes for both the individual product approval and the group approval processes. Immediately following the conclusion of the test an impact load is applied to the test specimen (Note that the impact load is not required for windows being tested under the group approval process). The impact test is designed to simulate the impact caused by a 3 kilogram sandbag dropped onto the window surface from a height of 50 centimeters. Following the conclusion of the impact test, the test specimen is visually evaluated to assess its performance. Approval of the fire rating is based on the visual assessment of the window's performance, Table 5.

Given the restrictions against the use of wood windows in fire and quasi-fire zones, a number of wood window manufacturers have undertaken the complicated process of having their wood windows certified as fire resistant. To date, a total of 21 companies (including two US firms) have succeeded in having 39 wood window models certified as fire resistant (Appendix D). This means that the windows can be used in residential construction in quasi-fire zones but not in fire zones. Those companies that have been successful in gaining certification for their windows, often emphasize this fact in their promotional material, Figures 36 and 37.



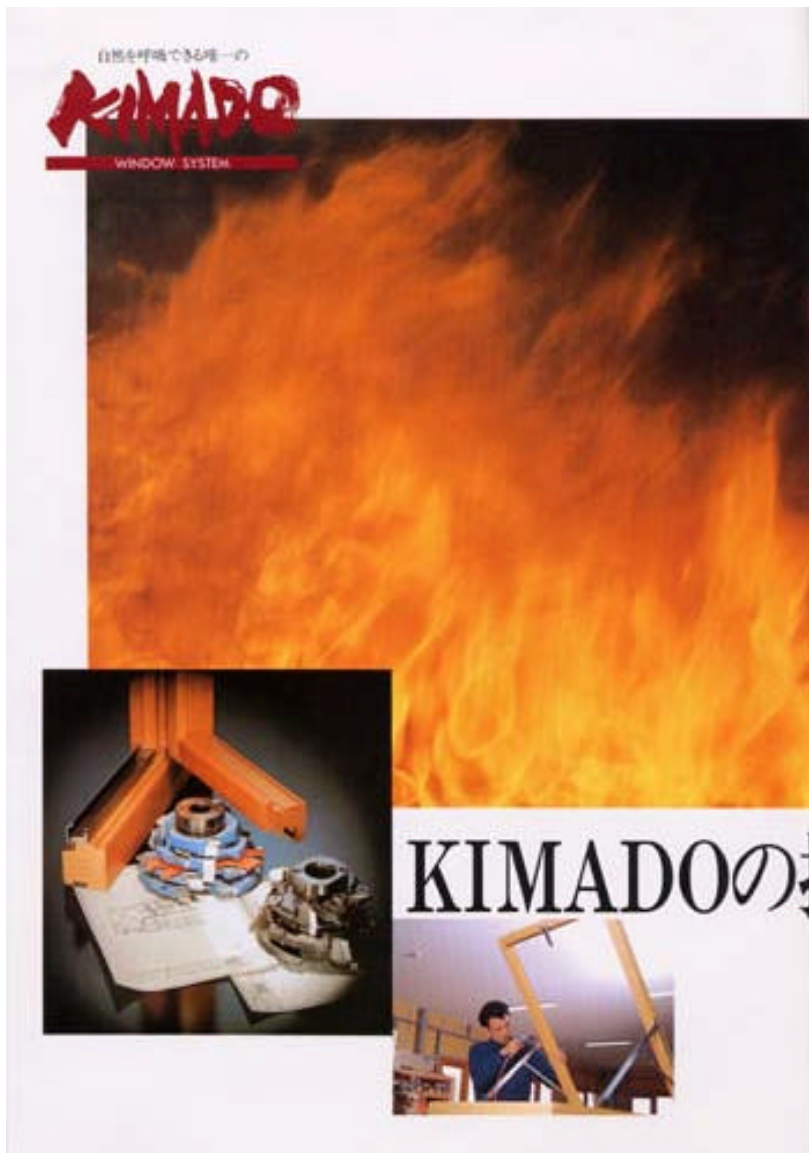

Figure 37. Promotional brochure for fire resistant Kimado wood widow.

**WWA** 全国主要サッシ製造商  
WWAは日本で制作される窓とドアの品質向上のための業界が結集した中立的な機関で、KIMADOも品質基準をクリアしている数少ないメーカーのひとつです。

**性能指標** アスト規格 国の日本住宅・建材規格センターにて  
熱貫流率——1.5Kcal/m<sup>2</sup>・h・°C (Low-Eペアガラス)  
耐風圧——10kPa (ペアガラス)  
耐雪荷——5kPa (ペアガラス)  
気密性——2.5等級以内

**建築基準** 乙種防火戸認定番号140号  
ペアガラスで日本独自の認定を受ける。  
(ペアガラス+2A95+F.L.D)

**新ベターリビング**  
KIMADOは日本で最も経験豊かなB/L認定メーカーです。B/Lとは、新ベターリビングが建築後の信頼を受けて認定される制度ある制度です。消費者保護、及び技術向上と広く業界に普及する事を目的としています。

**Wood** 高品質の狂目材  
オレゴン州(米国)にて厳選産輸入された狂目材を独自のVFD(バーチカル・フィンガー・ジョイント)加工により、より一層の品質向上につとめています。

**Glass** ダブルガラス、新熱、防火型ガラス等、豊富なバリエーションを揃えています。

**PAINT** KIMADOの塗料はアルキド系塗料をお勧めします。  
(工場塗装可能)

**SEAL** シール材はネオプレーン系を使用し、コーナーは電気溶着し強度の高いシール材として完成、水浸を防ぎます。

既設取付け 枠寸法: W×H / ハンドル

**FRAME & SASH**  
フレーム: 窓枠部  
サッシ: 障子部(可動部)  
W: 両開き  
H: 片開き  
ハンドル: 内開き  
以上の順にされています。

外開き 内開き

**Table 5. Summary of fire test methods and criteria.**

Test variable	Class A	Class B	
	Individual and group tests	Individual product test	Group approval test
Test temperature	800C	800C	800C
Test time	60 minutes	20 minutes	20 minutes
Burn area	Inside and outside	Inside and outside	Outside
Impact load	Required	Currently required	Not required
Pass criteria		<ol style="list-style-type: none"> <li>1. No formation of gaps or cracks through product</li> <li>2. No destruction, detachment which is detrimental to fire prevention when the impact load is applied</li> <li>3. No generation of flames on the back side of the test unit</li> <li>4. No generation of considerable smoke through to the other side of the test unit</li> </ol>	<ol style="list-style-type: none"> <li>1. No formation of gaps or cracks through product</li> <li>2. Not applicable</li> <li>3. No generation of flames on the back side of the test unit</li> <li>4. No generation of considerable smoke through to the other side of the test unit</li> </ol>

Burn area: where inside and outside tests are required, 2 units are tested individually, one for the outside surface and the other for the inside surface.

Impact load: a 3 kilogram sandbag is swung against the surface of the window unit with an impact load equivalent to a 3 kilogram sandbag being dropped onto the window from a height of 50 centimeters.

## **THE IMPACT OF CHANGES IN THE JAPANESE HOUSING CONSTRUCTION LAWS AND REGULATIONS**

As US manufacturers and exporters of wood products struggle to adjust to changes in the competitive environment in Japan, they are now being confronted with two regulatory changes that directly affect the Japanese residential construction industry. The revised Building Standard Law of Japan and the Housing Quality Assurance Law will significantly impact the structure of the residential construction industry in Japan, the mix of products that builders will use, and the range of services that they will require from suppliers in the future. In the following paragraphs, we will describe these regulatory changes and endeavor to explain their implications and the impact that they might have on the competitiveness of US manufacturers and exporters of wooden building materials, Appendices E and F.

### **Summary of Major Regulatory Changes in the Residential Construction Sector**

In May, 1998 the Building Standard Law of Japan (BSL) received its first major revision since 1950. The major revisions to the BSL: (1) specify interim and final building inspections and (2) transform the BSL from a specification-based building code to a performance-based building code. The first revision of the BSL requires that all residential housing units receive an interim and final inspection. Further, completion of the interim inspection is required before a building is eligible to receive its final inspection. Since there are only approximately 1,800 building inspectors in Japan, the BSL revisions will enable private construction inspection firms to be established. To provide guidance to the private inspection firms, a qualification system and standards has been established within the revised BSL. In the future, contractors will be allowed to obtain a construction inspection from either a private construction inspector or an inspector from the local government agency. Although the BSL revisions went into effect in May, 1999, given the shortage of inspectors in Japan, and the fact that many municipalities have not yet adopted the new inspection procedures, it is only now being phased in.

The second revision transformed the BSL from a specification-based standard to a performance-based standard. In the future, it is expected that any building material that meets the performance standards can be used in residential construction. While there is no mention about whether there will be reciprocity on test standards, the use of foreign test data is allowed in principle. Reciprocity would allow US firms to use the results of product tests conducted in the US in order to meet the performance standards in Japan to gain acceptance of their products. In addition, it is unclear how this change in the BSL will impact firms that have already gained Section 38 code approval for their products under the previous version of the BSL, though a two year grace period is allowed.

In addition to revising the BSL, the Housing Quality Assurance Act (HQAA) was also promulgated to provide home buyers with specific safeguards in resolving disputes with building contractors. The four objectives of the HQAA are to: (1) improve the quality and performance of residential homes, (2) provide home buyers with a mechanism for resolving disputes with building contractors, (3) establish a system of "Housing Performance Indication Standards" against which specific houses can be compared, and (4) establish a housing completion guarantee system. The HQAA, which went into effect in April, 2000, will significantly change the nature and structure of the residential construction industry in Japan, including the specification and use of domestic and imported wooden building materials (Appendix B). A more detailed assessment of the individual components of the HQAA is presented below.

The first objective of the HQAA is aimed at improving the quality and performance of new homes by requiring home builders to provide home buyers with a ten year warranty against structural defects and low durability (e.g., water infiltration into the structure). Under the guidelines of the HQAA, home buyers may make claims against home builders if the structural performance or durability of a home is judged to be sub-standard relative to a specific set of judgement criteria (which have yet to be published). These judgement criteria, which are expected to be published soon as a set of "Judgement Standards for Defects," will be prescriptive in nature and likely very detailed. For example, it is expected that a floor found to have a slope exceeding 6/1000 would require the contractor to take action to level the floor.

Since 1982 the Organization for Housing Warranty (affiliated with the Ministry of Construction) has provided ten year warranties for registered builders. Builders wishing to become registered with OHW simply pay a modest registration fee. As members of OHW, builders are required to cover all warranty costs during the first two years of the warranty period. However, during the remaining eight years of the warranty the builder is responsible for only a set amount of a warranty claim, with the remaining amount being covered by OHW. In the future it has been speculated that the two year exemption period may be removed given the fact that OHW has only paid out approximately ¥50 million while taking in registration fees in excess of ¥12 billion. With the ten year housing warranty guarantee now being mandatory, it will be interesting to see if OHW continues to provide registrations to all builders, regardless of size, financial stability, or qualifications.

There are a number of implications associated with this first component of the HQAA that are important to US manufacturers and exporters of wooden building materials. First, many small home builders will find it difficult to provide the requisite ten year warranty and they will be forced to either go out of business or become subcontractors for larger more financially stable firms. Second, most builders will look to use higher quality materials in their homes. This trend is already reflected in the fact that the use of dimensionally stable kiln-dried lumber in home construction has increased dramatically as has the volume of dry kiln capacity in Japan. Similarly, the use of glulam posts and beams has increased significantly, providing a tremendous market opportunity for kiln-dried European lamstock. Finally, home builders may look to the manufacturers and exporters of wooden building materials to provide extended warranty coverage for their products and in essence try to push the warranty responsibility back down the distribution channel towards export consolidators and manufacturers.

The second objective of the HQAA is to establish a mechanism for resolving disputes between home buyers and builders. To accomplish this objective, the HQAA mandates the establishment of Alternative Dispute Resolution (ADR) bodies in each prefecture in Japan. Each ADR will be staffed by a lawyer who will work to reconcile disagreements between builders and their customers during the ten year warranty period. Using the “Judgement Standards for Defects” as a guide, the lawyer will judge the severity of the defect against the standard to determine if a defect exceeds the allowable guidelines. If a defect is judged to be in excess of the allowable standard, then the builder will be required to correct the defect or compensate the homeowner.

The third objective of the HQAA is to establish a voluntary system of “Housing Performance Indication Standards” against which the performance of individual houses can be compared. The specific types of performance characteristics contained in this provision of the HQAA include: (1) structural performance, (2) fire safety, (3) durability, (4) ease of maintenance and management, (5) energy efficiency, (6) air quality, (7) ratio of exterior openings to total wall area, (8) noise transmission, and (9) barrier free design. The performance of individual houses will be judged by a “Designated Evaluation Body” using the criteria established in the “Japanese Housing Performance Indication Standards”. These evaluation bodies will be responsible for not only approving the architectural design of the house but will also perform inspections of the home during the construction process including the foundation process, structural framing process, and interior finishing phases of the project. Houses that are judged to meet or exceed the performance indication standards will receive certification as a “Performance Recognized House”, thus providing the builder with a way to differentiate their home from those of their competitors in their marketing material.

In addition, this section of the HQAA also makes provision for manufacturers of building components that meet the performance standards to become certified as “Authorized Manufacturers of Performance Components” thus providing them with some advantage in supplying their products to builders. While the performance indication system is voluntary, it is expected that once the Performance Indication Standards have been published, prospective home buyers will begin to insist that builders show how their homes compare to the performance standards and in this way it may become an informal requirement of the marketplace. To the extent that domestic manufacturers have an advantage over foreign manufacturers in gaining recognition as “Authorized Manufacturers of Performance Components”, this system has the potential to exclude foreign manufacturers and their products from a growing segment of the market.

Finally, the HQAA includes a provision for a Completion Guarantee System to protect home buyers against default by, or the bankruptcy of, their contractor prior to the completion of the home. This provision of the HQAA was

made necessary for two reasons. It is typical in Japan for the home buyer to provide up front financing to the contractor during the construction process. For example, it is not unusual for the home buyer to pay the contractor one-third of the price of the home before construction begins, with an additional third due after the house has been framed in and the remaining funds due upon completion of the house. This system may have worked well in the past but, given the current economic recession in Japan, a number of contractors have recently gone bankrupt, leaving home buyers with partially completed homes and outstanding payments due on building materials. The aim of the Completion Guarantee System is to provide home buyers with a form of insurance so that, in the event their builder goes bankrupt, funds will be available to complete the construction of their house.

To date, two organizations have been established to provide completion assurance guarantees. The first organization, Jutaku Anshin Assurance Company, is a privately funded effort between 52 national building material retailers (each of whom contributed ¥5 million) with substantial support from a consortium of four major Japanese insurance companies. The second organization, known as the Organization for Housing Warranty, is a publicly funded organization that will also provide completion guarantees to home buyers.

In order for a home builder to become a member of either of these organizations, they must submit a financial statement of their company for examination. Builders that are judged to be financially unstable will be unable to join either organization and therefore will be unable to provide their customers with a completion guarantee. It is estimated that there are approximately 160,000 contractors in Japan and less than 50,000 of them build more than ten homes per year while the remaining contractors tend to be very small firms who build less than 5 homes per year. Given this industry structure, it is widely expected that many of these small firms will not have the financial resources to join one of the Completion Assurance systems. Obviously, this will place these builders in an extremely weak position when they try to establish contracts with new customers. In fact, there is strong speculation that any new home construction being financed with a GHLC mortgage will be required to have a completion assurance guarantee issued prior to signing the construction contract.

This system of providing home buyers with completion assurance guarantees, particularly the privately funded Jutaku Anshin Assurance Company, has significant implications for manufacturers and exporters of wooden building materials. It can be expected that Jutaku Anshin will focus on recruiting the larger, more financially stable, builders into their program. To the extent that this relationship encourages member builders to purchase their building materials through member building material retailers, while discouraging relationships with non-member retailers or direct purchases from US manufacturers and consolidators, it could effectively restrict market access for US firms. The direct relationship between Japanese builders and US manufacturers and consolidators, which in the past had become an increasingly important distribution channel, could be phased out in favor of keiretsu-like relationships within the assurance group.

In summary, several factors have contributed to a substantial restructuring of the building code and regulations that affect the residential construction industry in Japan. The primary objective of the changes has been to increase the quality, performance, and durability of residential homes while providing home buyers with increased protection. However, a number of these changes have the potential to reduce the competitiveness of imported wooden building materials in Japan and severely restrict the ability of US manufacturers and exporters to sell directly to Japanese home builders. In addition, there is a strong likelihood that Japanese home builders (and wholesalers) will work to require that US manufacturers and/or exporters of wooden building materials provide extended warranties for their products that extend over the ten year warranty period. All of these factors are matters of concern for US manufacturers and exporters of wooden building materials who could see their position in the Japanese market undermined by the new building code revisions and regulations.



## CURRENT PROBLEMS IMPACTING THE COMPETITIVENESS OF US WOOD WINDOWS IN JAPAN

### THE IMPACT OF CULTURAL PREFERENCES ON WINDOW DESIGN

US windows are designed to provide protection against the elements while maintaining the thermal efficiency of the home. In order to accomplish these objectives, the seal around the sliding window sashes of a US window fit tightly to minimize air infiltration and moisture penetration. However, providing an effective air and moisture seal in a window necessarily increases the amount of force required to get the window moving (breaking force) and to maintain that movement (sliding force). Thus a trade-off exists between the weather tightness of a window and the force required to operate the window. Many Japanese are unaware of this relationship and often favor a Japanese window because of the ease of operation without understanding the impact of their choice on performance. This is particularly true of Japanese women and senior citizens. Given the temperature extremes and strong winds and rains experienced in Japan, it would seem that a tighter, more thermally efficient window would be attractive.

Japanese homeowners also have a strong preference for double slider (where both window panes slide) and casement windows that operate smoothly and require little force to move. In contrast, US homeowners more often favor energy efficient double hung windows or single slider windows (where only one pane slides and the other is fixed) with a stiffer movement that requires more force to move. While the Japanese preference for double slider windows does not pose a significant problem for US window manufacturers, the Japanese preference for windows that operate smoothly and require a minimal amount of force to move is more problematic and will require a targeted promotional campaign to communicate the trade-off's to Japanese builders and home buyers.

### METRIC SIZE OF BUILDING MODULE

With regard to the specification and use of US wood windows in Japan, it has often been speculated that the use of metric sizes by Japanese window manufacturers and the use of a different construction module has restricted the competitiveness of US windows in Japan. In the US, builders employ a four foot by eight construction module, while Japanese builders use a three *shaku* by six *shaku* (approximately three foot by six foot) module based on the size of a traditional *tatami* mat. As a result, whereas wall studs in the US are located at sixteen inches on center, wall posts in the post and beam system are located 910mm (35.8 inches) on center. In addition, the actual size of a *tatami* differs depending on the region, influencing the size of the building module used in different regions. For example, *tatami* in the Kansai region (the region around Osaka and Kobe) generally measure 1010mm by 1925mm while in the Kanto region (the region around Tokyo) they measure 910mm by 1820mm. A third system (referred to as *Chiho-ma*) is used in the countryside. In addition, rough opening sizes are called out according to three different measurement methods: center of post to center of post, outside edge to outside edge, and inside edge to inside edge. To further complicate things, the wall posts used in post and beam houses come in several sizes (105mm, 120mm, 130mm, or 150mm). As a result, aluminum window manufacturers in Japan provide literally thousands of different sizes for the multitude of module variations that occur.

To better explain the Japanese system, consider the following example. Assuming that the size of post being used is 105mm square, then the rough opening for a window located between adjacent posts is 805mm or 31.7 inches (910mm minus 2 times the width of a half post). Knowing this would theoretically allow a US window manufacturer to produce a window that fit into a post and beam module using a 105mm square post. However, the situation is not as simple as it seems. First of all, the post and beam system uses different post sizes, primarily 105mm square, 120mm square, and 130mm square. In addition, most houses are not built using a single size post. For example, in a three story house the balloon posts<sup>1</sup> (called *toshibashira*) are usually 130mm square while the infill posts located between them (called *kudabashira*) are frequently 105mm square. This combination of different size posts leads to

---

<sup>1</sup> Toshibashira posts extend from the foundation to the roof while kudabashira posts extend from the floor to the ceiling on each floor.

different size rough openings based on the size of post involved, complicating the calculation of rough opening sizes. Despite the different construction module employed in Japan, the use of metric sizes does not necessarily preclude the specification and use of US windows in post and beam construction.

During our visits to construction sites it was noted that the majority of windows had not been sized to fit the rough opening between adjacent posts. Rather, the rough opening for windows was often framed in between the posts to accommodate the different window sizes, Figure 38. Given this practice of in-fill framing for windows, it would be no more difficult for Japanese carpenters to frame in US standard size windows than Japanese metric size windows, a fact that our discussions with Japanese builders and carpenters confirmed. However, the different post sizes used in post and beam construction means that the casing width used to frame out the window in the wall varies based on the size of post being used. To address this complication, Japanese carpenters usually rip the window casing from a wide piece of casing on the job site after the window has been installed in the rough opening. In addition, Japanese windows generally have a wider extension outwards from the nail fins to take into account the additional thickness of the *dobuchi* used in the rain screen siding system (refer to *dobuchi* section that follows).



**Figure 38.** Windows are often framed in between the structural posts in Japan.

## **WEATHERPROOFING AND FLASHING**

Proper weatherproofing of windows is particularly important in Japan where typhoons and wind driven rain provide the perfect opportunity for rain water to penetrate into the cavity of a wall through improperly weatherproofed exterior wall openings. Another factor that contributed to this problem is related to the fact that, because houses are often three stories high and located close together in urban areas, roof eaves generally do not extend very far out from the side of the house. As a result, they are less effective in protecting the wall from falling rain. Lacking this protective feature, rain can hit the wall high up near the roof and flow down the side of the house as a sheet of water. As the water flows down the wall, hydrostatic pressure develops and this hydrostatic pressure can actually drive water into small openings around windows that have been improperly installed and/or weatherproofed.

In the past, Japanese architects and builders have located accent roofs over windows and doors as a method of directing the flow of water away from window openings, Figure 39. These accent roofs, which are called by a variety of names (including rooflets, accent roofs, window roofs, and window overhangs), extend approximately two to six inches beyond the window on either side, Figure 40. In this way, rain water flowing down the side of the house is directed away from the window opening, reducing the opportunity for water to penetrate into the wall cavity. In contrast, there is increased potential for water penetration when accent roofs are not used, particularly if the window is installed flush with the exterior wall, Figure 41.

Recognizing this problem, some aluminum window manufacturers are now integrating these accent roofs into their window designs, Figures 11 and 49. Builders have indicated that they prefer using windows that incorporate an integrated accent roof to having to incur the cost and time required to build a custom accent roof over each window as illustrated in Figure 40.



**Figure 39.** Small window overhangs on this older wooden house are an effective way to deflect rain water away from the window opening.



**Figure 40.** Some home builders build small accent roofs to protect windows from water flowing down the side of the wall.



**Figure 41.** Rain flowing down the exterior wall can penetrate this unprotected window opening and penetrate into the wall cavity as a result of hydrostatic pressure.



**Figure 42. Even in protected areas of the house, using waterproof tape around windows will help prevent moisture related problems.**

#### **RAINSCREEN SIDING SYSTEM (DOBUCHI)**

Rain screen siding is a system of placing the exterior wall siding onto a spacer strip so that a cavity is created behind the exterior siding and over the top of the primary moisture barrier (often a layer of building wrap such as Tyvek). The rain screen is used to protect the moisture barrier from wind driven moisture, provide an avenue of egress for water that finds its way behind the exterior siding, and allow the moisture barrier to dry out through evaporation if it does become wet, Figures 42-45.

The objective of the rain screen concept is to produce a high performance wall by providing several layers of protection for the underlying wall structure, thus reducing water penetration and collection. However, rain screen systems will only work effectively if they are properly designed and built. Using a rain screen does not eliminate the need for proper flashing around wall openings or the provision of regular maintenance.

A properly designed rain screen system provides an air cavity behind the exterior siding that allows air pressure differences to equalize on both sides of the siding during periods of intense wind and rain. Equalizing the pressure on both sides of the exterior siding reduces the ability of air pressure to force water into the wall cavity of the structure. However, this pressure equalization is only possible if the chamber behind the siding is open at the top and bottom of the wall, so that air can move quickly through the chamber. This open design allows equalization of air pressure on both sides of the siding and facilitates water drainage from behind the siding. One key to the rain screen system is that all seams of the house wrap must be properly sealed to prevent air and moisture penetration into the wall cavity or around windows and doors. In addition, exterior openings must be properly sealed as well, Figure 42 (Cheney 2000).

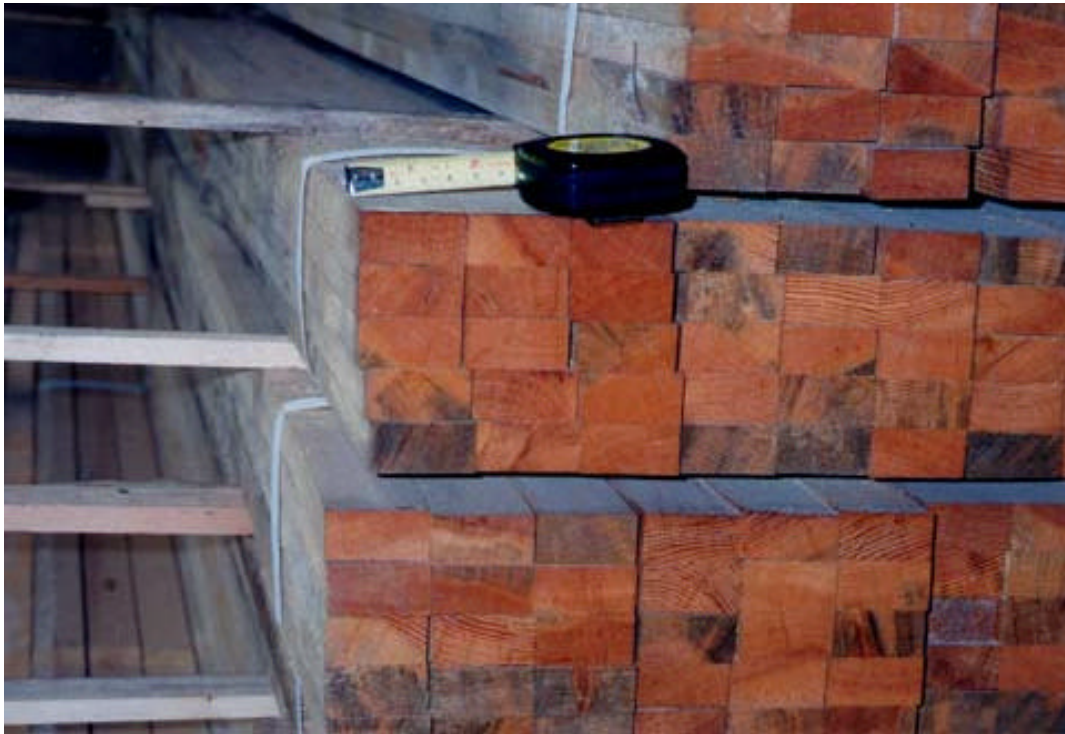

**Figure 43.** Wood dobuchi strips (20mm by 40 mm) are used in the rain screen siding system.



**Figure 44.** Windows are installed flush onto the dobuchi strips, thereby necessitating the use of a wider casing for the interior trim.



**Figure 45. These windows were installed flush with the wall and the dobuchi strips were added. This is not a recommended installation technique and can result in the exterior wall surface being flush with the window surface as shown in Figure 34.**

Because the window is installed over a spacer strip in the dobuchi system, it requires the use of a wider casing to trim out the interior of the window. As a result, over-wide casing strips should be included in window packages that will be used with a rain screen siding system. To address this complication, Japanese carpenters use jamb extenders to frame out the window after the window has been installed in the rough opening. In addition, Japanese windows generally have a wider profile outwards from the nail fins to take into account the additional thickness of the dobuchi strips used in the rain screen siding system. Technical drawings of a double slider window cross-section and a double hung window cross-section are provided in Figures 46 and 47.

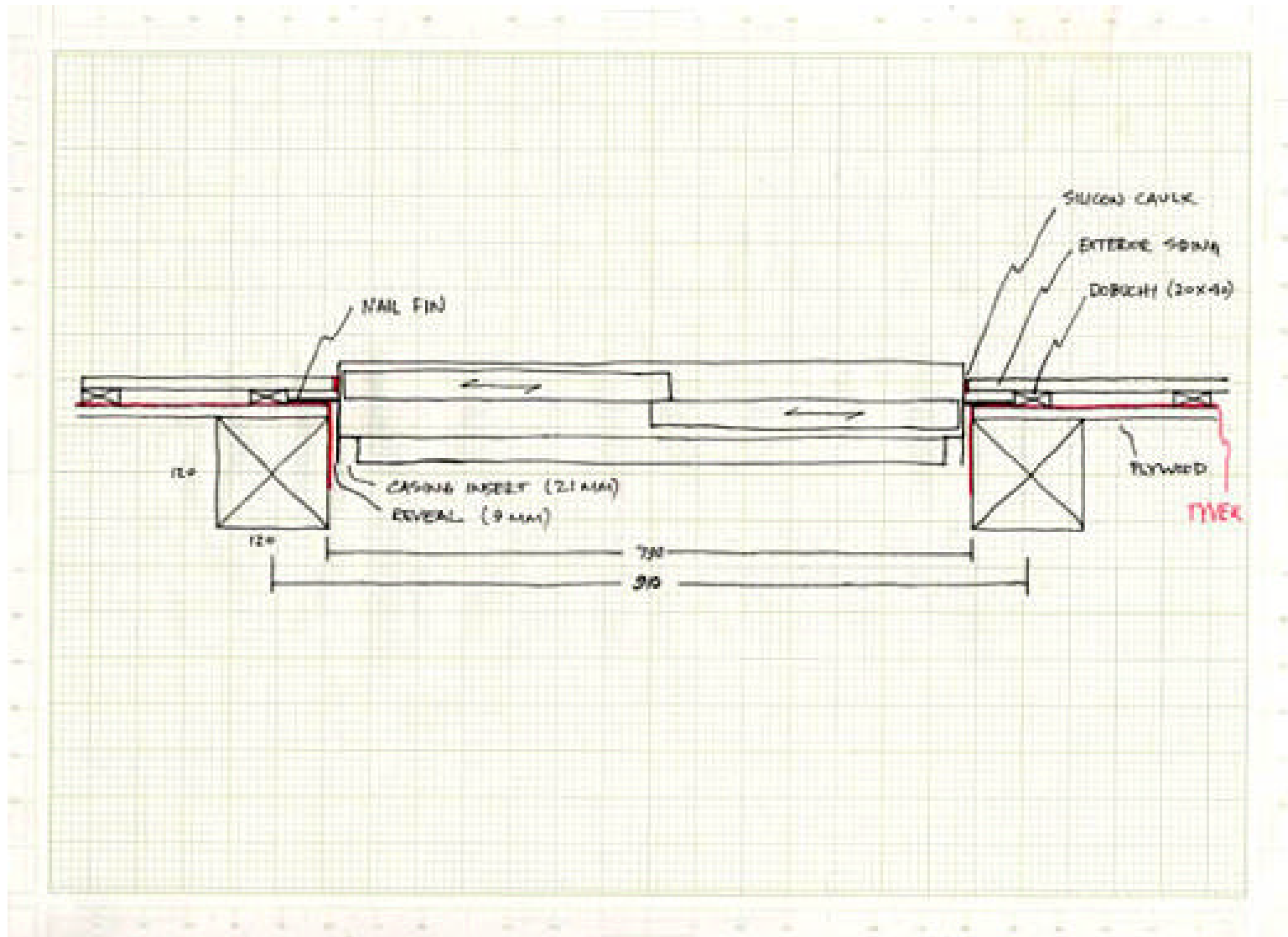

Figure 46. Technical drawing of a double slider window installed between posts with a dobuchi rain screen siding exterior. Note the space between the exterior siding and the window frame that is filled with a silicon caulk.

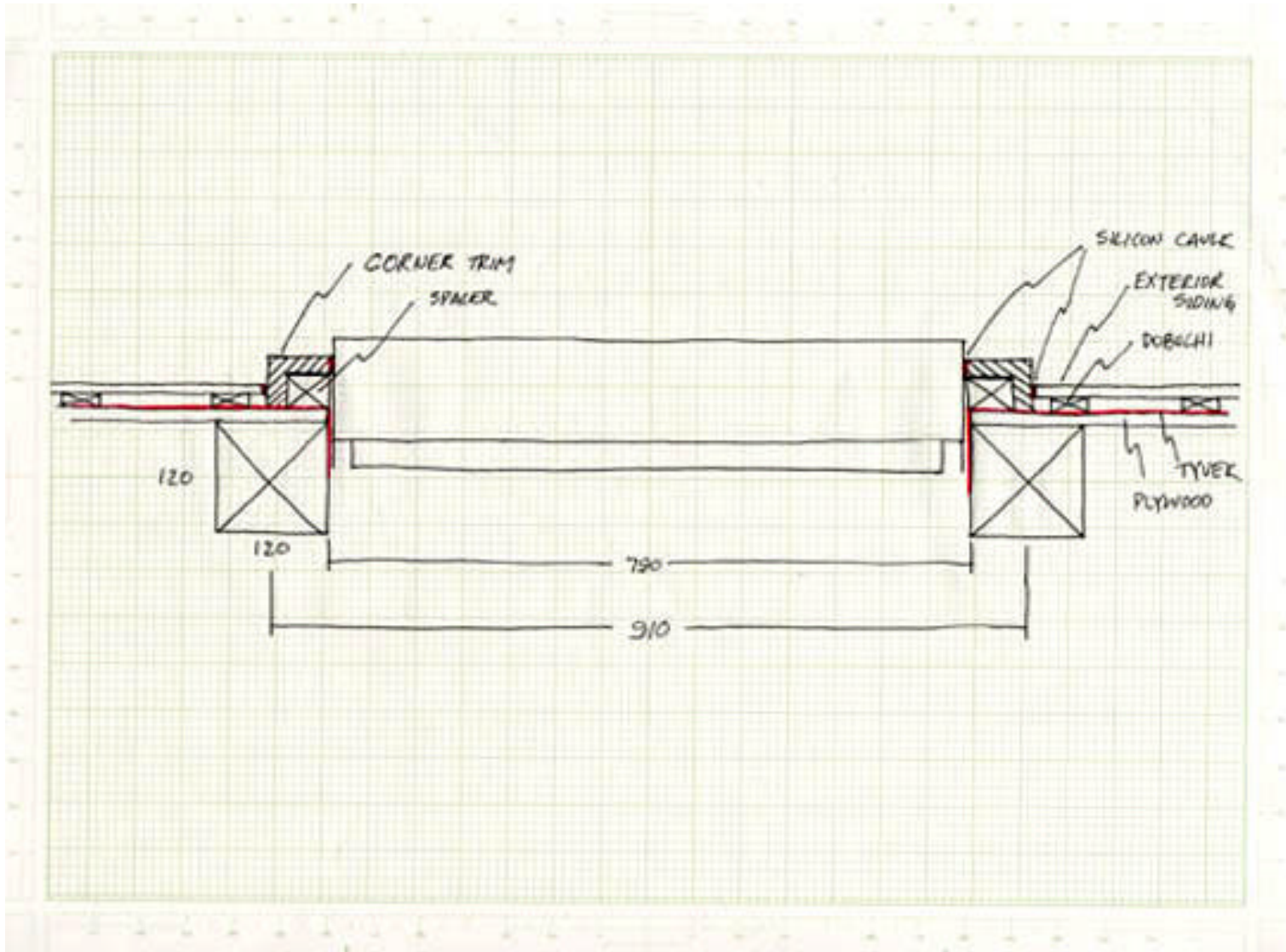

Figure 47. Technical drawing of double hung window with the dobuchi siding system. Note that the window is pulled away from the exterior wall with a spacer and the exterior siding butts up against the corner trim, not the window frame.

## HOME BUILDER EXPECTATION OF A BROAD RANGE OF ACCESSORIES AND SERVICES

As the window market has become more competitive and builder and home buyers have come to expect improved window quality and performance, Japanese window manufacturers have begun to offer a broader range of window accessories, Figures 9-11, 14-15, and 48-50. In addition, Japanese window manufacturers have substantially improved the quality and performance of their window products, although this has resulted in a corresponding increase in product prices.

One product feature to note is the use of a removable joint cover illustrated in Figure 48. This joint cover provides an effective method of covering any gaps that might exist between the casing and the frame of the window. The gaps could be the result of an inaccurate fit during the installation process or they could develop later as a result of shrinkage in the casing material. Use of the joint cover means that the carpenters do not have to worry about getting an exact fit between the casing and window frame. The joint cover is simply clipped into the base of the window following the installation of the window casing and its design allows for future removal if necessary.

In addition, although the inclusion of traditional *tatami* rooms in new houses is declining in Japan, a significant percentage of new post and beam homes includes at least one *tatami* room. Many of the builders interviewed indicated that the availability of specialized window casings for shoji screens was important and influenced their choice of window manufacturer. These interior casing products are referred to as *tategu* and include the top and bottom tracks in which the shoji screens slide (referred to as the *kamoi* and *shiji*, respectively).



**Figure 48.** Removable joint strip covers the small gap where the sash butts up to the window. Note that the interior sill of the window is white plastic lumber with a wood grain impression.



**Figure 49.** Some window manufacturers offer accent roofs as an option with a window package.



**Figure 50.** Detailed view of a shiiki (bottom track) for a sliding shoji screen illustrating how it slides under the casing return.

While some of these window accessories have been presented here, this report was not intended to provide a comprehensive summary of the broad range of product and service offerings available in Japan. This discussion should serve to highlight the fact that Japanese end-users wants and expectations differ substantially from those in the US. Thus, it is important that US window manufacturers looking to market their products in Japan conduct a thorough review of the products, accessories and service options that are being offered by their competitors in Japan, both domestic and foreign. For example, most window manufacturers and distributors provide their customers with interest-free credit (referred to as *tegata*) for various time periods. For the builder facing cash flow problems, this service alone may be enough to influence their choice of window supplier.

### **LACK OF TECHNICAL SUPPORT**

While the major window manufacturers (principally aluminum window manufacturers) provide installation services, the majority of windows in Japan are installed by carpenters. This means that installation instructions must be clearly presented and translated into Japanese to help ensure that the window is properly installed. Equally important are the instructions related to the installation of weather stripping materials both prior to and following the installation of the window. As mentioned earlier, one of the most frequently cited problems with new construction by homeowners was related to water infiltration around windows. A second major complaint was related to the fact that windows became difficult to open and close after a period of time. Both of these complaints are related to poor installation techniques.

It was observed on a couple of job sites that carpenters tended not to read the installation instructions very thoroughly, even when they had been translated into Japanese. As a result, window manufacturers need to seriously consider the possibility of providing on-site technical support for builders and carpenters in Japan. This support person could accomplish several objectives: 1) provide technical training seminars for builders and carpenters, 2) provide technical support for customers (both in terms of installation and weather proofing the window), and 3) provide rapid assessments for liability and defect claims. An on-the ground technical support person should be an important consideration for any US window manufacturer looking to establish a presence in Japan.

### **READY AVAILABILITY OF REPLACEMENT WINDOWS AND PARTS**

While a window is a remarkably strong and durable product when installed in a house, they are subject to a wide variety of problems during transport. Since they have little control over the shipping and transportation process, window manufacturers should be prepared to deal quickly and effectively to settle warranty claims in Japan. Given the long lead times required to ship products by ocean freight and the relatively short response times required to settle a claim, many US window manufacturers ship replacement parts and even entire window assemblies via air shipments. Not only is this expensive, but it is subject to the problems inherent in any transaction involving two languages and cultures. Thus, anecdotes abound of misunderstandings in parts specifications that resulted in the timely shipment of the wrong part. This can easily be avoided if a technical support person and an inventory of commonly requested replacement parts are established in Japan.

### **LACK OF WINDOW MAINTENANCE AND UPKEEP BY HOMEOWNERS**

Another important fact to recognize is that Japanese homeowners rarely perform even the most basic maintenance on their homes, a fact that wood window manufacturers should especially be aware of. Since land values in Japan are several times higher than the cost of a house, most Japanese regard homes as a durable good rather than an investment. In fact, the lack of a secondary housing resale market in Japan only further exacerbates this problem. Given the critical importance of regular maintenance to the durability and performance of wood windows, particularly in a hot and humid climate like Japan's, US wood window manufacturers need to ensure that easy to read maintenance instructions (in Japanese) are delivered to the homeowner. This can be problematic since most maintenance materials are not saved by carpenters. Again, an in-country technical representative can work with builders to make sure that maintenance materials are delivered to the homeowners after they have moved into their new home.

To obtain more detailed information on the problems encountered in specifying, utilizing and installing US wood windows and doors, the results of a survey administered to 87 Japanese builders and architects are summarized in Appendix G. The surveys were administered following each of four technical seminars on the correct techniques for installing US wooden windows and doors into Japanese post and beam homes.

**Table 6. Summary of technical observations based on construction site visits in Japan.**

<b>Technical Observations</b>	
1	Lack of maintenance will adversely impact the performance and durability of wood windows in Japan, particularly given the hot, humid climate and frequent typhoons. Maintenance materials should be provided to the homeowner
2	Wood windows should be pre-primed or finished immediately following installation otherwise they can pick up moisture, causing paint bubbles later as the absorbed moisture tries to escape in hot weather.
3	Manufacturers should consider providing flashing in factory colors and finishes to direct water flowing down the exterior wall away from the window surface. This is important because houses in Japan are close together and often don't have wide eaves to protect windows.
4	When windows are painted, the paint should overlap onto the window surface slightly (approximately 1mm).
5	Foam corner covers should be placed over the corners of the nail fins and caulked to prevent water infiltration. The nail fins and corner covers should then be covered with a double width of Tyvek tape.
6	Many Japanese carpenters use returns with wood casings to hide any gaps between the window and casing caused by shrinkage or a poor fit.
7	Since wall thicknesses in the post & beam system vary based on the post size used, jamb extensions should be shipped loose so that they can be cut to size on-site.
8	The weight of double hung US windows, their stiff movement and the height of the upper sash are perceived to be problems, particularly by Japanese women and the growing senior population.
9	The relationship and trade-off between air infiltration, water infiltration, sound transmission, energy efficiency and the ease of sash movement need to be better communicated to Japanese home builders and home buyers.
10	In general, casement windows over 30 inches in width tend to sag, making closing difficult.
11	Awning windows are well suited for use in Japanese bathrooms because they can be left open to allow air circulation while still providing protection from rain.
12	Providing wide jamb extenders is important not only because of variable post sizes and rain screen siding, but also because some rooms will be <i>ohkabe</i> (with exposed posts) while others will be <i>shinkabe</i> (covered posts).
13	Need to provide good maintenance and operating instructions ( <i>in Japanese</i> ) because many Japanese home owners are confused by window options that Americans take for granted (e.g., removing screens, using window locks, and using crank handles).
14	Carpenters are often uncertain how to install sliding shoji tracks on the interior of US wooden windows when they are used in traditional tatami rooms.
15	Windows must be installed on top of dobuchi strips when the rain screen siding system is used, otherwise the window is recessed behind the exterior siding and rain water flows easily across the window surface.
16	Technical support and parts availability are important considerations for builders when specifying windows.
17	Japanese home buyers value window features, such as motor driven roll up exterior screens and European tilt-and-turn hardware.



## CONCLUSIONS

This project supports the idea that standard US wooden windows can be incorporated into the post and beam construction system used in Japan. However, product design and accessories as well as the range of support services offered by Japanese window manufacturers have a substantial impact on the competitiveness of US windows in Japan. US wooden window manufacturers (including clad wood windows) need to ensure that their windows are properly installed, finished, and maintained in order to ensure that their long-term durability and performance meets Japanese expectations. Significant technical and installation issues exist and US manufacturers must take the initiative to develop training programs and strategies to effectively address these issues so that window performance meets homeowner expectations.

While the fire codes in Japan describe the performance standards that windows must meet, it is interesting to note that the fire codes specify that aluminum is a non-combustible material and therefore exempted from the performance standards. Several people in Japan noted that, although it is difficult for wooden windows to meet the performance standards specified in the fire codes, to date approximately 15 wooden windows have been certified as meeting the fire code criteria. In contrast, they noted that most aluminum windows used in Japan, if exposed to the test criteria described in the fire tests, would melt and fail early on in the test process. It is obvious that the exemption of aluminum as a non-combustible material has played a critical role in providing aluminum window manufacturers with their dominant position in the industry.

During our visits to construction sites it was noted that the majority of windows had not been sized to fit the rough opening between adjacent posts. Rather, the rough opening for these windows was often framed in between the posts to accommodate the size of each window. Given this practice of in-fill framing for windows, it would be no more difficult for Japanese carpenters to frame in US standard size windows than Japanese metric size windows, a fact that our discussions with Japanese builders and carpenters confirmed. However, the different post sizes used in post and beam construction means that the casing width used to frame out the window in the wall varies based on the size of post being used. To address this complication, Japanese carpenters usually rip the window casing from a wide piece of casing after the window has been installed in the rough opening. So what is limiting the specification and use of US wood windows in Japan? Certainly price is one factor. But beyond this, product design and the range of services offered are equally important factors.

Another factor that impacts the window specification decision relates to the fact that Japanese home builders are usually provided with a range of services by domestic window manufacturers and wholesalers that are often not available from US manufacturers and exporters. These services include extended credit (*tegata*), on-site product delivery, on-site installation crews, and locally available parts and replacement windows.

This research suggests that standard US window sizes can be easily accommodated within the post and beam construction system used in Japan. However, product design and the range of services being offered have a substantial impact on the competitiveness of windows in Japan. US wood window manufacturers should at least consider the following factors to increase the competitiveness of their products in the future: 1) establishing of training and education programs for Japanese builders and carpenters, 2) developing a certification program for Japanese window installers and carpenters, 3) producing and distributing a generic window installation manual in Japanese, and 4) maintaining technical support, parts and product inventory in Japan. This research clearly shows that with a well thought out strategy, US wood window manufacturers could be competitive in the Japanese post and beam segment of the residential construction industry.



## BIBLIOGRAPHY

- Cheney, David, 2000. Wood Window and Door Installation. Presented at the US Building Materials in Post & Beam Construction Seminar. Seattle, WA.
- Gilhooly, B. and T. Uranaka, 1999. Complaints of Shoddy New Homes on the Rise: Poor Workmanship Shattering Dreams. The Japan Times, 31 December; pp:3.
- JETRO, 1997a. Marketing Guide-Wooden Windows and Doors. Japan External Trade Organization. Tokyo.
- JETRO, 1997b. Japanese Market Report Regulations & Practices, Metal Building Fixtures No.2. Japan External Trade Organization. Tokyo.
- U.S. Foreign Commercial Service and U.S. Department of State, 1997. Japan – Wood and Vinyl Windows – ISA970601 Market Research Report, June 1997.
- Japan Sash Association, 1998. Study Regarding the Current Condition of Building Materials Used for Residential Housing. Tokyo.
- Oshima, Sumiko, 2001. Outside the Box. The Japan Times, 10 June; pp:9-10.
- US&FCS, 1997. Wood Windows and Vinyl Windows. Industry Sector Analysis. 24 pages.
- [www.tostem.co.jp](http://www.tostem.co.jp), Tostem Corporation Web Site
- [www.sankyoalumi.co.jp](http://www.sankyoalumi.co.jp), Sankyo Aluminum Industry Corporation Web Site
- [www.ykkap.co.jp](http://www.ykkap.co.jp), YKK Architectural Products Inc. Web Site
- [www.shinnikkei.co.jp](http://www.shinnikkei.co.jp), Shin Nikkei Corporation Web Site
- [www.tateyama.co.jp](http://www.tateyama.co.jp), Tateyama Aluminum Industry Corporation Web Site



# APPENDICES



**APPENDIX A: JAPANESE WOOD WINDOW MANUFACTURERS**

*(based on 1999 membership directory of the Japan Wood Window Association).*

<b>Company name</b>	<b>Address</b>	<b>Telephone</b>
Island Profile Company, Ltd.	2-13-15 Ikegami, Ota-ku, Tokyo 146	3-3754-7043
Oide Sangyo Company, Ltd.	4-12-18 Toyo, Koto-ku, Tokyo 135	3-3645-9178
Oharasanwa KK	6-4-13 Umeda, Adachi-ku, Tokyo	3-3889-6601
Kamo Tategu Kyodo Kumiai	16-6 Kotobuki-machi, Kamo-shi, Niigata 959	2-5652-0893
Kawakami Seisakusho Company, Ltd.	339-22 Kogyo-danchi, Murakami-shi, Niigata 958	2-5453-3030
Kimado Company Ltd.	1-1 kami Akae-cho, Toyama-shi, Toyama 930	7-6441-1423
Kyowa Mokko Company, Ltd.	22-2 Owada Minami, Suwa-shi, Nagano 392	2-6679-5531
Koshiyama Company, Ltd.	100 Osuga, Kawatogawa, Noshiro-shi, Akita 016	1-8554-3214
Seren Company, Ltd.	17-7-1 Futukaichi-cho, Fukui-shi, Fukui 910	7-7655-1675
Taisei Tategu Company, Ltd.	Kakezukuri-cho 9, Wakayama 640	7-3422-2634
Tanaka Tategu	14 Aza-Usui, Futatsui-cho, Yamamoto-gun, Akita 018	1-8573-4916
Tanaka Mokuzai Kogyo Company, Ltd.	288-1 Akaike, Nakagawa-cho, Naka-gun, Tokushima 779	8-8442-1130
Tokushu Mokuka Kogyo Company, Ltd.	177 Shimomumata-cho, Mumata, Gunma 378	2-7823-2622
Try Wood Company, Ltd.	2716 Oaza Kamibaru, Kamitsue-mura, Hita-gun, Oita 977	



**APPENDIX B: AN OVERVIEW OF THE RE-EXAMINATION OF THE CONSTRUCTION CODE  
PERFORMANCE STANDARDS INITIATIVE FOR FIRE RESISTANT STRUCTURES AND FIREPROOF  
MATERIALS.**

1. Performance Base Standards Initiative Regarding Fire Resistant Structures and Fireproof Materials, etc

Regulations based on laws are being changed from codes based on required specification regulations to a regulation system based on technical performance standards. In relation to this, the required performance standards, test methods, etc for this technical code is scheduled to be determined and then officially announced.

Additionally, certified fireproof materials and fire resistant materials will be changed to a system that directly regulates the required performance. The required performance standards, test methods, etc for this technical code is scheduled to be determined and then officially announced.

2. The Adoption of Fire Resistant Design Methods

Currently, fire resistant structures must be structures such as steel and concrete. However, based on a re-evaluation of the definition of fire resistant structures, a fire resistant design law was adopted to ensure fire resistant performance. This includes taking into account special characteristics such as the layout of open space in the building when calculating the fire resistant performance. Along with this, the fire resistant design law will specify a method to confirm if the required fire resistant performance levels are met or not. This is scheduled to be determined by law and announced. Based on this, it will be possible to reduce large scale wooden domes and fireproof coverings.

3. The Rationalization (*Improvement*) of Fire Codes Regarding Roofs, etc of Wooden Structures.

Based on the law reformation, the ability to prevent fire spreading from roofs, etc will be changed from specific regulations system to a direct confirmation system. Along with this, the required performance standards, test methods, etc for this technical code is scheduled to be determined and then officially announced. Based on this, various building methods such as roofs with built in solar panels will become possible.

4. Adoption of Evacuation Calculation Law

Regarding structures such as large scale buildings, an evacuation calculation law will be adopted to ensure the safe evacuation of building users. The technical standards will be define by the evacuation calculation law to ensure whether the required evacuation safety procedures are met or not. The required performance standards, test methods, etc for this technical code is scheduled to be determined by a law and announced. Based on this, regulations will be rationalized (*improved*) hallways, the width of entrance and exists, and distance of routes (*to exits*).

## 5. The Introduction of the New Structural Calculations Law Regarding Earthquake Safety, Etc.

### (1) Introduction of New Structural Calculations Law Regarding Performance Standardization.

The current earthquake resistant design calculations for loads and external forces and assuring the ability to adjust (e.g. *sway to absorb shock*) were combined. However, the new method introduced makes it possible to calculate the strength used to resist earthquakes and adjustment performance (e.g. *sway to absorb shock*) at the same time (using maximum resistance method *genkai tairyoku ho*). The application of uniform specification regulations will be phased out.

### (2) Consolidation of Codes Regarding Technology That Has Been Standardized

Regulations will be introduced by an official announcement regarding performance inspection methods and specification regulations. This will be done for diffusion and definitions of technology that has already been standardized by the construction standards law article 38 regulation.

The introduction of new building methods and new materials for earthquake resistant structures and new building methods using imported materials, etc should be made smoother by the above re-examination.

## 6. The Introduction of Performance Inspections For Building Facilities

Performance inspection methods will be introduced through performance tests, etc

for building facilities such as elevators and waste tanks. This will make the adoption of items such as foreign products and products utilizing new technology.

## 7. The Re-Examination of Sanitary Related Standards Including (*Natural*) Lighting

### (1) Deregulation of Lighting Standards

Regulations will be rationalized by the exemption of office rooms other than those used as living rooms. This will rationalize (*improve*) the areas covered by the regulations. Additionally, regarding areas effective for (*natural*) lighting, up until now the distance to the adjoining property line and amount above the fixed distance according to the height of your building were decided equally. However, there will be rationalization by using an area calculation method based on methods such as the percentage of window area space. Based on this, even areas that, up until now were not effective for (natural) lighting, will be able to become living spaces due to the window becoming larger.

### (2) The Deregulation of Basement Living Rooms (*i.e. rooms for living*)

The regulation that, in general, prohibited living rooms in basements is being reformed. The committee covering basement rooms will clarify the required sanitary regulations and this will simplify construction.

New Versus Old Provisions of the Construction Standards Law Regarding Fireproof Doors (An Example)

Old: (Definition of Specialty Words)

Provision 2 “Fire Resistant Building”

A building where a majority of the structure is a fire resistant structure. Also, it has fire resistant doors

and windows within the structure defined by an ordinance and placed in areas where there is fear of spread of fire from openings.

New: (Definition of Specialty Words)

Provision 2 “Fire Resistant Building”

Any building that falls within the following definition.

A. The main parts of the structure are either (1) or (2).

(1) The building is a fire resistant structure.

(2) The building’s abilities that are listed below come under the technical standards that are defined by an ordinance (the main parts of the structure other than exterior walls is limited to the ability provided in (i) below).

(i) The Structure of a Proper Building

The ability to withstand flames and heat that occur from a fire (of a scope that can be expected) through the building’s *fire fighting* equipment and their use until the fire has been extinguished.

(ii) The ability to withstand the flames and heat of a normal fire from a neighboring building until the fire has been extinguished.

B. In areas where there is fear of the fire spreading from exterior opening areas, fire resistant doors (*and windows*) and fire fighting equipment (the structures ability\* to block flames is determined by the technical standards defined by an ordinance and is limited to building methods utilizing items defined by the minister of construction or somebody approved by the minister of construction) specified by an ordinance must be used.

\*this means the ability to block a fire effectively utilizing the necessary fire prevention equipment for the ordinary (*average*) time of a fire.

The current situation of the test inspection method.

Existing (*Inspection Method*): The Heat Test + The Shock Test (The Ministry of Construction Announcement No. 1125, 1990 Japan)

Proposal (*For New Inspection Method*): A Standard Heat Test Aiming at Being Combined With ISO-834 Test Method.



## APPENDIX C: SUMMARY OF FIRE DOOR TEST METHODOLOGY

Wood windows and doors used in fire zones must pass the 60 minute test, while in quasi-fire zones they must pass the 20 minute test. For unrestricted areas they do not have to pass any fire test. However, even in a few cases in quasi-fire zones the 20 minute rating need not apply if there is sufficient egress or distance between two structures. As for the test methodology for wood windows, a 20 minute burn is required on ONLY ONE side of the window/door for group approval. Also for group approval the impact test has been dropped. There is no sandbag test. The 60 minute rating still requires the impact test and burn on both sides of the window/door specimen (outside and inside). The salient points of the fire test methodology for fire doors and windows in Japan are as follows:

- In 1990 the tests were amended and the ISO standard heating temperature curve was introduced in lieu of the former Japan-developed heat curve.
- Under the new heating temperatures, heating time was changed from 30 minutes to 20 minutes so that the temperature-time area (total heat load) in the new testing methods was slightly relaxed.
- No generation of flames on consisting materials while heated and no remaining of fires after the end of heating are no longer required in order to allow use of the fire doors/windows using combustible materials such as wood.
- Objective description was included in judgment criteria instead of subjective description so that performance as fire doors/windows was clearly judged.
- General Approval or Group Approval contents are the same as an individual approval. However, a group of manufacturers, or builders will apply for the certification and the object of the general approval is not individual products but standardized specifications prepared by the applicant group of manufacturers/builders which allow a certain range of product designs variations.

A Comparison of the fire test criteria prior to the amendment and following the implementation of the amendment.

	<b>Before Amendment</b>	<b>After Amendment</b>
Heating temp curve	Secondary Fire protection Heating Temperature Curve – JIS A1311	ISO Heating Temperature Curve
Heating Time	30 minutes	20 minutes
Judgment criteria	<ul style="list-style-type: none"> <li>- No deformation, destruction to its fire prevention properties shall be observed.</li> <li>- No penetration of flames damaging its fire prevention properties shall be observed.</li> </ul>	<ul style="list-style-type: none"> <li>- No formation of gaps/cracks through to the other side</li> <li>- No destruction, detachment which is detrimental to fire prevention when the impact load of a sandbag (3kg swung @ 50 cm)</li> <li>- No generation of flames on the back side</li> <li>- No generation of considerable smoke through to the other side</li> </ul>
	No generation of flames on remaining materials shall be observed and no remains of fires for 5 min or longer after the heating shall be observed.	- deleted
	The temperature of the copper plate is located at 3 cm from the back side is less than 260 C degrees.	- deleted

**APPENDIX D: CERTIFIED FIRE RESISTANT JAPANESE WOOD WINDOWS**

<b><i>Certification Number</i></b>	<b><i>Certification Date</i></b>	<b><i>Company Name</i></b>	<b><i>Product Name</i></b>	<b><i>Phone</i></b>
1433	10/25/91	Nyuusuto Inc	Good Wood W-20	03-5261-8881
1437	12/11/91	Sappororo Wood Association Center	Wood Window A Type	
1438	12/11/91	Sappororo Wood Association Center	Wood Window DK Type	
1460	6/1/92	Kimado Inc	Kontora F	076-441-1423
1475	10/5/92	Nord Inc	Nord Fenstar FK Type	011-758-3446
1476	10/5/92	Nord Inc	Nord Fenstar FU1-Out	011-758-3446
1477	10/5/92	Nord Inc	Nord Fenstar FU1-In	011-758-3446
1480	11/24/92	(Can't Find)		
1500	2/15/93	Woody Asahi Kawa Association	NT Cezar Wood Fireproof WT-20	
1502	2/15/93	Woody Asahi Kawa Association	NT Cezar Wood Fireproof FWT-20	
1503	2/15/93	Tomoku Inc	FRW-T	086-426-0018
1509	3/12/93	Seren Inc	Seremado FF1	
1518	5/10/93	Kimado Inc	Casement F	
1519	5/10/93	Kimado Inc	Slider F	
1520	5/28/93	Shinmiya Shoko Inc	Olympia Window CF	011-644-1011
1521	5/28/93	Shinmiya Shoko Inc	Olympia Window F	011-644-1011
1522	5/28/93	Shinmiya Shoko Inc	Olympia Window C	011-644-1011
1566	4/14/94	(Can't Find)		
1586	11/14/94	Tomoku Inc	FRD-T	086-426-0018
1589	11/29/94	Seren Inc	Seremado FF3	

1590	11/29/94	Seren Inc	Seremado FF2	
1595	2/10/95	Fujita Inc	Window Lead	011-281-7102
1622	9/14/95	Best Tech Inc	Bestech TVF	03-5478-8193
1625	9/14/95	Seren Inc	Seremado FF4	
1643	12/19/95	Mitui Homes Inc	MA20F	089-933-8031
1644	12/19/95	Mitui Homes Inc	MA20T	089-933-8031
1690	1/19/19	Tamiya Factory	Wood Window Dorekippu	0745-83-1000
1694	2/17/97	Gaderi Usu Inc	Elite Fenstar Wood Window	022-776-0501
1706	4/4/97	Japan Velux Inc	Roof Window (skylight) GGL Type	03-3478-8141
1733	10/8/97	Kichimoto Contractors Inc	Brusute ERIT Awning?	
1734	10/8/97	Yoshimoto Contractors Inc	Brusute ERIT Slider?	0743-53-5491
1759	6/3/98	Ai Emu Inc	Rotating Handle Open Out Window Sweden Type EFH	
1762	6/19/98	Bitaresuku Inc	All Back	
1764	8/19/98	Kyu sash Inc	Wood Window A	
1765	8/19/98	Kyu sash Inc	Wood Window B	
1767	9/10/98	Kyu sash Inc	Wood Window Slider?	
1770	11/20/98	Japan Velux Inc	Velux Total Floor Space	03-3478-8141
1771	11/20/98	Sekusui Chemical Industries Inc	W3 D 2206	0120-27-7256
1772	11/20/98	SekusuiChemical Industries Inc	W3 DK 1608	0120-27-7256

## APPENDIX E: SUMMARY OF THE HOUSING QUALITY ASSURANCE ACT

### Housing Quality Assurance Act

#### 1. Purpose

- (1) The assurance of housing quality
- (2) Protection of the interests of housing purchasers
- (3) Prompt resolution of disputes related of housing

(Ref.) Number of consultations concerning housing (quality of construction work of detached houses) brought to Japan Consumer Information Center (JCIC)

	FY1994	FY1995	FY1996	FY1997
Total	15500	18000	21000	22000
Consultations concerning safety, quality, etc.	2500 (16%)	3300 (18%)	4200 (20%)	4300 (20%)

#### 2. Housing Performance Indication System

The Housing Performance Indication System is completely voluntary, and application is at the discretion of housing suppliers and consumers.

##### (1) Japan Housing Performance Indication Standards and Evaluation Methods Standards

The "Japan Housing Performance Indication standards" consist of the items which should be stated concerning the housing performance and the methods to state them. The "Evaluation Methods Standards" is regarding how to evaluate the level of performance.

[Figure 1 : Image of Housing Performance Indication System]

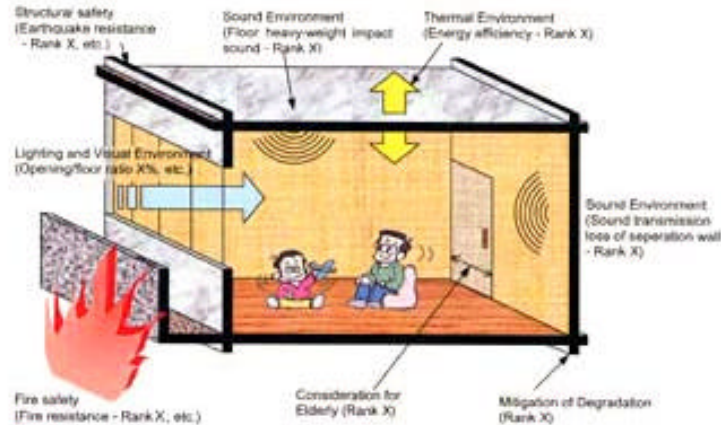

##### (2) Housing Performance Evaluation by Designated Evaluation Bodies

[Figure 2 : Process of Housing Performance Evaluation]

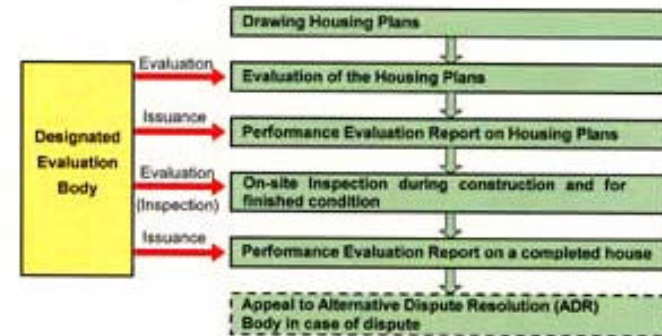

- 1) Designated evaluation bodies (designated by the Minister of Construction) may, by request, conduct housing performance evaluation (of plans or of constructed houses) in accordance with the "Japan Housing Performance Indication Standards" and the "Evaluation Methods Standards," and issue Performance Evaluation Reports marked with a special logo.
- 2) Nobody, except for the case mentioned in 1), can put the aforementioned logo or any other similar logo on evaluation reports regarding housing performance, on contracts (undertaking or sale), or on attached documents thereof.
- 3) In cases where Performance Evaluation Reports or their copies are attached to contracts, or where they are given to the consumers, contractors of new houses will take liabilities to deliver houses with the level of performance indicated in the reports, unless otherwise stipulated in the contracts. (Equally, the sellers of new constructed houses will take liabilities to deliver new constructed houses with the level of performance indicated in the reports.)

##### [Housing Performance Type Approval, etc.]

In order to evaluate the housing performance efficiently, the following measures could be taken:

- 1) Simplification of evaluation procedure for housing with standardized design (Housing performance type approval). And, simplification of evaluation procedure for housing with industrialized production method (Products manufacturer approval)
- 2) Application of exceptional evaluation methods (ones not stipulated in the "Evaluation Methods Standards") to cope with new technology, etc. (Special evaluation method approval)

**(3) Housing Dispute Resolution System**

[Figure 3 : Dispute Resolution of Performance-Evaluated Houses]



**3.Enforcement of 10 Years Liability for Defects**

[Enforcement of Liability for Defects of New Houses]

Building parts concerned	Certain parts of following parts of new house -The principal building parts for structural stability (foundations, columns, floor slabs, etc.) -Parts preventing the penetration of rain water (roofs, exterior walls, etc.)
Claimable contents	-Repair claims (not stipulated for sales contracts under the current Civil Law) -Compensation claims -Cancellation (limited to sales contracts only when repairs are not possible)
Liability period	10 years obligation after delivery (Shortening the period to less than 10 years is valid under the current Civil Law)

#Special contracts more disadvantageous to purchasers than above-mentioned are invalid.

[Figure 4 : Image of housing parts for which 10 years Liability is mandatory ]\*\*\*

Example of detached house  
by the post & beam wooden construction

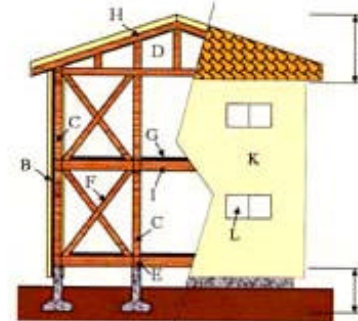

[Principal building parts for structural stability]

Foundations	A
Walls	B
Columns	C
Roof frames	D
Sills	E
Diagonal Members	F
Floor Slabs	G
Roof Slabs	H
Horizontal Members	I

[Parts preventing the penetration of rain water]

Roofs	J
Exterior walls	K
Openings	L

Example of collective house  
by the reinforced concrete construction (wall structure)

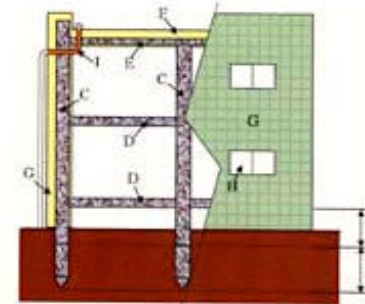

[Principal building parts for structural stability]

Foundations	A
Foundation piles	B
Walls	C
Floor Slabs	D
Roof Slabs	E

[Parts preventing the penetration of rain water]

Roofs	F
Exterior walls	G
Openings	H
Drainage pipes	I

**4.The Date of Application**

"Enforcement of Liability for Defects" has come into effect at the same time as the operation of the law since 1<sup>st</sup> of April 2000. It was applied for contracts of buying new houses concluded after 1st of April 2000. Housing Performance Indication System has come into effect from the 3<sup>rd</sup> of October 2000.

## APPENDIX F: SUMMARY OF CHANGES IN THE JAPANESE HOUSING CONSTRUCTION LAWS

### A. Revision of Building Standards Law of Japan

- Requires interim and final inspections of new homes
- Established a qualification system for private inspection companies
- Shift from a specification-based to a performance-based system

### B. Housing Quality Assurance Law

1. 10 year warranty system
2. Establish Alternative Dispute Resolution Bodies
3. Construction Completion Guarantee Systems (Public and Private)
4. Voluntary Housing Performance Evaluation and Indication System

#### *1. 10 Year Warranty System*

- Builders must provide home buyers with a 10 year warranty against defects in structural durability of major components and damage due to rainwater infiltration
- Defects will be evaluated against a set of “Judgment Standards for Defects” that will specify defect criteria (e.g., floors that slope more than  $X/1000$ )

#### *2. Alternative Dispute Resolution Bodies*

- ADR’s will be established in each prefecture
- ADR’s will arrange a lawyer to reconcile disputes between home buyers and builders

#### *3. Construction Completion Guarantee Systems*

- Voluntary system for insuring the completion of residential construction projects if the primary builders becomes insolvent
- Voluntary system but will greatly advantage qualified builders
- Builders can get completion guarantees from public or private organizations

- Private: Jutaka Anshin Assurance Company
- Public: Organization for Housing Warranty
- Builders with poor financial status will be excluded and most likely lose substantial business
- Completion assurance certificates may become required for GHLC funded projects

#### ***4. Housing Performance Evaluation and Indication System***

- Voluntary system to improve housing quality and performance
- Evaluation of high performance houses will be done private sector Designated Evaluation Bodies based on an evaluation of architectural plans and subsequent inspections of the construction project
- Will lead to “Performance Recognized Houses” and “Authorized Manufacturers of Performance Components”
- Includes 9 proposed performance articles (i.e., structure, fire safety, durability, easy maintenance/management, energy efficiency, air quality, natural light, noise insulation, and senior/handicapped design)
- Will facilitate the comparison of house performance against an established minimum

## APPENDIX G: JAPAN WOOD WINDOW SURVEY AND RESULTS

(For the purposes of this survey, wood windows are defined to include both solid wood windows and aluminum clad wood windows)

1. Have you ever used wood windows in Post and Beam homes?      ▶ Yes      ▶ No

2. Have you ever used NA wood windows in Post and Beam homes?      ▶ Yes      ▶ No

3. How satisfied have you been with the performance of wood windows?

Not Satisfied		Somewhat Satisfied		Very Satisfied
1	2	3	4	5

4. What factors restrict your use of wood windows in Post and Beam homes?

a) \_\_\_\_\_  
b) \_\_\_\_\_  
c) \_\_\_\_\_

5. What technical problems have you encountered installing wood windows in Post and Beam homes?

a) \_\_\_\_\_  
b) \_\_\_\_\_  
c) \_\_\_\_\_

6. Do you expect to increase or decrease your use of wood windows in the future?

▶ Stop using      ▶ Remain the same      ▶ Increase somewhat      ▶ Greatly increase

7. In your opinion, do wood windows provide superior performance compared to metal windows.

▶ Yes      ▶ No

8. What factors restrict the increased use of North American wood windows in Post and Beam homes?

\_\_\_\_\_  
\_\_\_\_\_  
\_\_\_\_\_

9. When you build a Post and Beam home, who usually installs the windows?

▶ carpenter      ▶ window manufacturer  
▶ subcontractor      ▶ other, please specify: \_\_\_\_\_

10. Approximately how many homes do you build per year? \_\_\_\_\_

## Survey Results

### Imported Wood Windows and Doors for Post and Beam Houses

Survey Responses : 87 in total for the four venues (over 200 participated)

**What type of business are you in?**

Builder	34
Architectural design	18
Building materials dealer	10
Building materials wholesaler/distributor	12
Other	8

**Which Seminar did you attend?**

Tokyo	17
Kitakyushu	31
Hiroshima	13
Osaka	26

**Q1: For those who use double-paned thermal windows, what proportion is:  
Imported?**

<b>100%</b>	<b>90%</b>	<b>80%</b>	<b>70%</b>	<b>50%</b>	<b>40%</b>	<b>30%</b>	<b>20%</b>	<b>15%</b>	<b>10%</b>	<b>5%</b>	<b>2%</b>	<b>1%</b>
(17)	(4)	(2)	(1)	(5)	(1)	(2)	(5)	(1)	(2)	(3)	(1)	(1)

**Domestic?**

<b>100%</b>	<b>99%</b>	<b>98%</b>	<b>95%</b>	<b>90%</b>	<b>85%</b>	<b>80%</b>	<b>70%</b>	<b>60%</b>	<b>50%</b>	<b>30%</b>	<b>20%</b>	<b>10%</b>
(10)	(1)	(1)	(3)	(3)	(1)	(7)	(2)	(1)	(7)	(1)	(2)	(4)

**Q2: For those who use imported windows and doors, which building method do you use?**

North American 2x4	30
Japanese 2x4	26
Post and Beam	30
Pre-fab	1

**Q3: When purchasing American window products and doors, how much importance do you place on the following?**

	WINDOWS					<i>total</i>
	<i>No Importance</i>		<i>Essential</i>			
	<i>1</i>	<i>2</i>	<i>3</i>	<i>4</i>	<i>5</i>	
Reasonable price	0	6	22	20	32	(80)
Appropriate style	1	2	13	25	40	(81)
Multifunctionality	1	6	30	19	23	(79)
Good thermal efficiency	1	1	9	21	49	(81)
Good durability	1	1	7	23	45	(77)
Easy maintenance	0	2	12	22	36	(72)
Easy installation	0	3	23	20	29	(75)
Other						

	<b>DOORS</b>					<i>total</i>	
	<i>No Importance</i>						<i>Essential</i>
	<i>1</i>	<i>2</i>	<i>3</i>	<i>4</i>	<i>5</i>		
Reasonable price	0	2	16	27	33	(78)	
Appropriate style	0	0	8	19	51	(78)	
Multifunctionality	3	8	33	15	21	(80)	
Good thermal efficiency	2	4	19	12	39	(76)	
Good durability	1	2	13	17	46	(79)	
Easy maintenance	0	4	16	20	38	(78)	
Easy installation	0	4	20	22	29	(75)	
Other							

**Q4: Have you ever had a problem using American-made windows or doors?**

**A) Function    YES 24                      NO 19**

***Please specify***

1. Twisting, warping. (5).
2. Bad opening (due to lack of adjustment and warping) (2)
3. Window doesn't stay in the middle. (2)
4. Leakage (2).
5. Metal fittings often come off. Screws of vinyl windows tend to not work.
6. Water leakage in vinyl band windows.
7. Insufficient strength of vinyl sashes.
8. Metal fittings often come off.
9. Customers have a better image of domestic window products.
10. Rails/stiles of door break off. Technical Seminar
11. Lack of support from suppliers.
12. Springs of single-hinge and double-hinge windows loosen.
13. Post-installation service.
14. Procurement of parts.
15. Screens for aluminum windows needed modification since Japanese prefer sliding screens, not fixed.
16. Water leakage inside the frame.
17. How can the extension frame be installed to fit the thickness of the wall?
18. Water leakage from the top part of panel pivoting window
19. Problems too numerous to list.
20. When rebuilding, the size of openings was limited.
21. Hinges.
22. Hung windows are heavy when opening and closing.
23. Difficult adjustment after installation.
24. Water came in from a wooden panel of the front door.
25. Casement handle wore out and didn't work.

**B) Installation:            YES 18                      NO 20**

***Please specify:***

1. The weight of the product itself is too heavy. (3)
2. Twisting of door frame. (2)
3. I lost some hinges; getting replacements was difficult
4. Carpenters did not know the proper method of installation; they did it their own way.
5. Incline in large-size windows, including bay and bow windows.
6. How should screws be handled at the time of installation?
7. How to modify thickness for the interior frame of the window.

8. Problems with shim.
9. Japanese customers don't like nails and screws to be visible.
10. Difficult to adjust.
11. French door got stuck in the frame; refused to open.
12. Since large patio doors have glass, sometimes I didn't know how to install them.

**C) What are specific problems have you had installing imported doors and windows in post and beam houses? Please specify:**

1. How to install imported windows and doors with a 114 mm thick wall for 2x4 into post and beam with a 127-145 mm thick wall. Also, how to finish the interior. (2)
2. Explanation about the size of openings.
3. Sizes need to be in metric.
4. Carpenters lack knowledge and experience with imported building materials.
5. It needs to be understood that imported products are somewhat imprecise compared to Japanese products.
6. When there is a difference in the level of the exterior wall (main studs and sub studs), an aluminum sash that I usually use was much easier.
7. Frame of large window (like a patio door) tends to warps.
8. There are still many instances of incorrect installation.
9. Since the pillar size for post and beam is different from 2x4, installation is difficult.
10. How to install windows and doors directly to the stud.
11. For windows, the exposed outer part is too small. 40-45 cm for the finished size is needed.
12. Hinge is thin and metal screws rust quickly.
13. Regarding the building frame, shrinkage and expansion of the material is more common in post and beam than in 2x4. Treatment (not only to prevent water from entering the window sill) which allows water to drain should be considered. For imported wooden sashes, Mitsui Home set up spacers on the top of the window and covered it with a waterproof sheet in order to allow water to drain.
14. Screen door got torn and took much time to repair.
15. I think interior solid oak fittings tend to crack.
16. Since the installation method hasn't been established, it takes too much time to install for first time users.

**Q5: For those who have had trouble with installation, how beneficial was this seminar?**

<i>Not at all</i>				<i>Very helpful</i>
<i>1</i>	<i>2</i>	<i>3</i>	<i>4</i>	<i>5</i>
(1)	(1)	(14)	(20)	(15)

**Q7: What information did you expect to gain from this seminar?**

1. Correct installation method. (5).
2. How to obtain fireproofing certification and information. (3)
3. Installation method for post and beam; waterproof treatment and ways to purchase. (2)
4. I wanted to find as many Japanese agents as possible to purchase from.
5. The data in this seminar was very useful.
6. Installation method would be specific and easy to understand.
7. I wanted information on waterproof treatment.
8. I wondered if it would be possible for bulk purchases of doors and windows of the same standard.
9. Installation method to prevent water leakage.
10. How to deal with accidents.
11. Maintenance.

12. I wanted to hear from people who actually use imported materials in post and beam including specific problems and how they dealt with them.
13. Correct installation of house wrap and waterproofing for windows and doors.
14. Differences in performance between Japanese and American windows
15. I would like windows and doors that fit Japanese legal standards.
16. Method to install sashes directly to studs without affixing to plywood in post and beam.
17. Distribution routes and product supply.
18. This was a good seminar which was easy to understand for dealers.
19. I would like a video showing the [installation] process .
20. The seminar was what I expected.
21. It was very helpful to see real installation by American workmen.
22. I wanted to know if American doors and windows are certified as a type B firedoor. I wonder if we have to continue using rain shutters.
23. I expected explanations on how to install [windows and doors] for a Japanese-style tatami room.
24. Japanese builders are so used to using aluminum windows they have forgotten how to handle wooden fittings.
25. Latest product information.

**Q8: What hinders your use of American-made windows and doors?**

	WINDOWS					<i>total</i>
	<b>The least</b> <i>1</i>	<i>2</i>	<i>3</i>	<i>4</i>	<b>The most</b> <i>5</i>	
Delivery takes too long	3	4	12	18	29	(66)
Procurement is troublesome	12	7	14	12	20	(65)
Lack of Installation information	5	9	19	13	16	(62)
Insufficient product guarantee	3	5	19	19	20	(66)
Lack of customer support	4	6	18	23	17	(68)
Lack of product information in Japanese	6	14	27	11	23	(81)
Incompatibility with J. building methods	12	15	24	5	6	(62)
Too expensive	6	14	25	6	8	(59)
Same as Japanese window products	6	18	24	8	0	(56)
Same as other imported windows	9	17	27	5	0	(58)
Other						

	DOORS					<i>(total)</i>
	<b>The least</b> <i>1</i>	<i>2</i>	<i>3</i>	<i>4</i>	<b>The most</b> <i>5</i>	
Delivery takes too long	1	6	9	18	27	(61)
Procurement is troublesome	9	15	11	14	16	(65)
Lack of Installation information	6	10	15	14	15	(60)
Insufficient product guarantee	2	5	22	19	19	(67)
Lack of customer support	3	5	15	22	20	(65)
Lack of product information in Japanese	5	7	17	10	20	(59)
Incompatibility with J. building methods	11	12	29	2	3	(57)
Too expensive	7	13	25	5	5	(55)
Same as Japanese window products	9	15	23	13	0	(60)
Same as other imported windows	10	15	25	6	0	(56)
Other						

**Q9: Do you have any other comments or opinions about today's seminar or American windows and doors?**

1. It was very helpful. (5)
2. I would like more technical guidance about other areas by American workmen invited to Japan. (2)
3. Although it is said that American windows and doors can be installed in post and beam houses, there is no consideration about structure. It seems that the same installation method for 2x4 is applied to post and beam.
4. I would like a technical seminar for installation and coordination of interiors, including molding, wallpaper and curtains.
5. I would like to see further deregulation. Customs procedures are complicated. All off-loading port charges are the same, and the container transportation fee is too expensive.
6. I already have used imported windows and doors and came to the seminar for a review; it was very good.
7. The door knobs look cheap compared to Japanese products.
8. Since there is demand from builders, I will handle imported windows and doors in the future.
9. I have run an exhibition for imported building materials in Kobe for five years and consumers have begun to understand the merits of imported materials.
10. I would like metal parts for windows and doors to be stocked by Japanese dealers.
11. I would like American suppliers to sell the products in Japanese sizes. At the very least, I would like makers to manufacture an extruded-style window (half of the window comes out from the wall).
12. There should be more explanation about handling wooden products. Also, I think it's good to hear about problems and how they were dealt with.

**APPENDIX H: US EXPORTS OF WOOD PRODUCTS TO JAPAN, 1989-1999**

	1990	1991	1992	1993	1994	1995	1996	1997	1998	1999
chips	\$375,680,068	\$451,497,298	\$418,075,980	\$378,550,036	\$394,196,359	\$484,792,224	\$499,616,635	\$439,417,913	\$430,855,701	\$368,156,532
fiberboard	\$2,342,274	\$1,487,645	\$1,885,361	\$1,639,621	\$3,005,773	\$6,447,773	\$3,030,205	\$2,048,013	\$1,264,949	\$662,568
hardboard	\$97,824	\$63,412	\$122,285	\$404,287	\$734,879	\$1,474,453	\$298,002	\$221,089	\$316,153	\$91,219
hardwood logs	\$55,031,580	\$51,044,294	\$42,413,291	\$53,836,870	\$45,990,961	\$52,260,423	\$49,509,752	\$48,828,647	\$35,525,934	\$34,936,162
hardwood lumber	\$138,357,492	\$138,445,543	\$132,801,917	\$152,362,385	\$134,501,053	\$151,169,659	\$136,278,949	\$138,674,913	\$71,534,835	\$81,320,880
hardwood veneer	\$13,030,041	\$15,423,345	\$14,956,394	\$14,453,408	\$14,297,679	\$12,939,525	\$7,260,354	\$11,441,642	\$4,302,998	\$5,584,612
mdf	\$3,081,308	\$2,715,237	\$1,983,063	\$2,372,909	\$4,112,330	\$3,194,386	\$1,974,106	\$1,690,757	\$176,158	\$191,718
osb + waferboard		\$38,816	\$57,885	\$335,679	\$830,264	\$3,604,372	\$6,974,286	\$13,898,416	\$7,248,117	\$5,690,871
other primary	\$5,563,832	\$4,809,370	\$4,066,701	\$5,104,294	\$8,772,650	\$5,615,270	\$5,719,839	\$10,405,230	\$7,663,477	\$14,938,474
particleboard	\$4,389,525	\$3,595,569	\$3,467,824	\$2,390,194	\$2,034,725	\$2,253,845	\$4,864,963	\$7,449,826	\$6,684,040	\$7,473,438
plywood	\$4,233,474	\$6,696,142	\$5,107,072	\$14,325,172	\$12,003,173	\$13,949,627	\$12,716,750	\$14,783,813	\$3,264,644	\$3,003,966
poles, piles and posts	\$4,973,377	\$4,082,164	\$3,193,365	\$10,153,778	\$12,438,473	\$8,531,932	\$7,273,486	\$5,655,477	\$511,985	\$901,322
railroad ties	\$33,316	\$120,921	\$20,286	\$427,034	\$76,797	\$6,100	\$12,916	\$221,103	\$335,028	\$284,947
softwood logs	\$1,585,486,489	\$1,332,536,707	\$1,503,165,936	\$1,833,399,892	\$1,727,193,731	\$1,668,608,146	\$1,640,196,529	\$1,096,602,277	\$706,689,201	\$697,547,501
softwood lumber	\$500,881,984	\$491,980,846	\$498,498,795	\$612,736,195	\$625,507,122	\$618,567,357	\$649,542,659	\$439,368,950	\$183,805,360	\$204,094,191
softwood veneer	\$5,187,571	\$8,627,767	\$8,824,563	\$16,831,668	\$15,788,036	\$13,130,996	\$12,496,357	\$5,667,491	\$1,384,892	\$1,677,440
<b>Primary Total</b>	<b>\$2,698,370,155</b>	<b>\$2,513,165,076</b>	<b>\$2,638,640,718</b>	<b>\$3,099,323,422</b>	<b>\$3,001,484,005</b>	<b>\$3,046,546,088</b>	<b>\$3,037,765,788</b>	<b>\$2,236,375,557</b>	<b>\$1,461,563,472</b>	<b>\$1,426,555,841</b>
casks and barrels	\$1,631,203	\$512,909	\$351,098	\$290,136	\$439,124	\$1,265,530	\$581,446	\$453,835	\$1,280,078	\$1,380,960
fab. struc. wood members	\$3,500,960	\$4,245,727	\$3,450,698	\$8,871,924	\$13,362,281	\$22,730,912	\$38,290,703	\$19,518,792	\$7,892,402	\$8,098,142
hardwood flooring	\$5,273,327	\$4,176,847	\$3,603,051	\$2,933,614	\$3,860,960	\$5,790,763	\$7,474,940	\$6,367,440	\$3,868,737	\$3,871,924
hardwood moulding	\$13,321,608	\$9,580,641	\$1,141,080	\$972,072	\$2,253,180	\$4,785,892	\$4,991,162	\$4,014,180	\$2,978,427	\$972,368

misc. secondary	\$15,273,561	\$13,624,302	\$16,710,979	\$18,435,865	\$18,613,977	\$27,116,339	\$31,014,818	\$26,330,118	\$20,743,768	\$24,782,671
other builders joinery	\$35,201,870	\$33,331,947	\$24,400,858	\$21,776,389	\$27,120,698	\$55,471,672	\$62,575,853	\$60,686,113	\$40,713,704	\$33,665,705
pallets and packing cases	\$1,093,880	\$629,850	\$1,211,007	\$2,545,260	\$2,577,490	\$4,387,614	\$2,943,569	\$2,655,922	\$2,973,071	\$1,984,694
parquet panels of wood	\$145,307	\$72,886	\$189,820	\$98,984	\$137,580	\$278,129	\$82,690	\$94,654	\$147,285	\$141,674
softwood flooring	\$1,895,047	\$1,378,399	\$1,691,752	\$3,005,284	\$1,702,684	\$3,302,730	\$5,528,946	\$4,893,822	\$1,679,742	\$2,093,064
softwood moulding	\$1,542,615	\$3,209,957	\$2,520,063	\$3,000,193	\$4,604,016	\$4,393,810	\$2,894,505	\$4,074,994	\$2,221,758	\$1,538,975
treated lumber	\$538,927	\$366,805	\$287,946	\$354,656	\$1,238,130	\$1,516,945	\$2,303,330	\$10,073,753	\$6,475,538	\$4,285,306
wood doors, frames, etc	\$10,212,264	\$10,828,211	\$9,019,455	\$8,018,150	\$12,195,489	\$26,799,881	\$47,132,551	\$39,788,236	\$16,300,472	\$14,910,096
wood furniture parts	\$241,872	\$270,790	\$461,765	\$313,736	\$617,651	\$2,270,409	\$1,372,836	\$2,537,749	\$2,768,573	\$1,327,357
wood household furniture	\$24,435,814	\$29,759,217	\$34,478,780	\$31,649,003	\$44,731,329	\$48,229,984	\$56,661,847	\$51,656,304	\$36,927,038	\$38,007,104
wood kitchen cabinets	\$1,707,172	\$1,964,922	\$1,547,013	\$730,970	\$2,204,058	\$3,033,244	\$13,410,550	\$4,928,817	\$3,386,233	\$2,762,032
wood or wood frame seats	\$1,993,507	\$4,436,036	\$4,618,948	\$3,902,159	\$7,092,891	\$8,792,649	\$15,552,248	\$14,325,565	\$8,544,065	\$8,428,329
wood windows and frames	\$6,738,990	\$5,264,840	\$5,702,672	\$5,953,030	\$10,465,665	\$17,970,841	\$21,733,889	\$21,888,277	\$16,924,506	\$19,555,927
wooden office furniture	\$1,187,091	\$2,163,983	\$1,526,310	\$1,590,555	\$1,301,974	\$3,154,202	\$2,322,644	\$3,514,695	\$2,344,918	\$1,225,510
wooden prefab buildings	\$18,657,976	\$15,856,009	\$14,575,652	\$18,143,809	\$32,102,867	\$50,745,297	\$70,839,263	\$73,075,300	\$40,715,084	\$38,864,448
<b>Secondary Total</b>	<b>\$144,592,991</b>	<b>\$141,674,278</b>	<b>\$127,488,947</b>	<b>\$132,585,789</b>	<b>\$186,622,044</b>	<b>\$292,036,843</b>	<b>\$387,707,790</b>	<b>\$350,878,566</b>	<b>\$218,885,399</b>	<b>\$207,896,286</b>
<b>Grand Total</b>	<b>\$4,127,194,287</b>	<b>\$3,865,892,598</b>	<b>\$3,950,946,157</b>	<b>\$4,373,555,299</b>	<b>\$4,417,064,899</b>	<b>\$5,150,426,485</b>	<b>\$4,832,595,860</b>	<b>\$3,853,519,142</b>	<b>\$2,789,041,874</b>	<b>\$2,739,379,053</b>

