

The function and diversity of the antiretroviral restriction factors TRIM5 α and TRIMCyp
in Old World primates

Elizabeth A. Dietrich

A dissertation
submitted in partial fulfillment of the
requirements for the degree of

Doctor of Philosophy

University of Washington

2012

Reading Committee:

Shiu-Lok Hu, Chair

Adam Geballe

Jaisri Lingappa

Program Authorized to Offer Degree:

Microbiology

ABSTRACT

The retroviral restriction factors TRIM5 α and TRIMCyp, encoded in the *TRIM5* gene, prevent cross-species transmission of retroviruses in primates. In macaques (genus *Macaca*), TRIMCyp evolved through the retrotransposition of a cyclophilin A sequence into the *TRIM5* gene. In this work, I examine the evolutionary origin and geographic distribution of TRIMCyp, and I describe functional variability in both TRIM5 α and TRIMCyp. I focus on *M. sylvanus*, because of its status as an evolutionary outgroup, and on *M. fascicularis*, which is commonly used as a model species for AIDS research. I show that TRIMCyp evolved approximately 5-6 million years ago in the common ancestor of the Asian macaques, after their divergence from *M. sylvanus*, and that the genetic changes leading to TRIMCyp expression are variably distributed in *M. fascicularis* populations. I demonstrate that multiple TRIM5 α and TRIMCyp alleles, with different antiviral specificities, are present in the *M. sylvanus* and *M. fascicularis* populations, respectively. Finally, I show that coexpression of *M. fascicularis* TRIM5 α and TRIMCyp does not lead to the loss of restriction capability by either protein. The functional diversity of TRIM5 α and TRIMCyp restriction factors in macaques may have important consequences for their use as HIV/AIDS models. This work helps to define some of the parameters that may affect retroviral infection of nonhuman primate species.

TABLE OF CONTENTS

List of Figures	ii
List of Tables	iii
Chapter 1. Introduction.....	1
Chapter 2. Materials and Methods	21
Chapter 3. Evolution of the Antiretroviral Restriction Factor TRIMCyp in Old World Primates ...	26
Chapter 4. Variable Prevalence and Functional Diversity of the Antiretroviral Restriction Factor TRIMCyp in <i>Macaca fascicularis</i>	46
Chapter 5. The Effect of Coexpression of <i>M. fascicularis</i> TRIM5 α and TRIMCyp	64
Chapter 6. Conclusions.....	76
References	88

LIST OF FIGURES

Figure 1. Restriction factors in the retroviral life cycle.....	2
Figure 2. Domain structure of TRIM5 proteins showing TRIM5 α , TRIM5 γ , TRIM5 η , and macaque TRIMCyp	4
Figure 3. Geographic distribution and phylogenetic relationships of selected Old World primate species.....	17
Figure 4. Genome structures of selected primate lentiviruses	18
Figure 5. Genomic organization and mRNA splicing of <i>TRIM5</i> alleles.....	28
Figure 6. Baboons lack TRIMCyp.....	31
Figure 7. <i>M. sylvanus</i> lack TRIMCyp.....	32
Figure 8. TRIMCyp-linked alleles form a monophyletic group.....	33
Figure 9. Single <i>M. thibetana</i> and <i>M. nigra</i> individuals lack TRIMCyp-related genetic changes.....	34
Figure 10. Restriction activity of <i>M. sylvanus</i> TRIM5 α	37
Figure 11. Model for TRIMCyp evolution in Old World primates	39
Figure 12. Genomic organization and mRNA splicing of <i>TRIM5</i> alleles.....	49
Figure 13. <i>NsiI</i> restriction analysis of <i>TRIM5</i> genotype in <i>M. fascicularis</i> populations.....	50
Figure 14. PCR analysis of <i>CypA</i> insertion in <i>M. fascicularis</i> populations.....	51
Figure 15. Phylogenetic tree of intron 6 – exon 8 region	52
Figure 16. Expression and antiviral restriction activity of <i>M. fascicularis</i> TRIMCyp	55
Figure 17. Amino acids 369 and 446 determine TRIMCyp restriction activity	56
Figure 18. Amino acid 178 affects TRIMCyp protein expression or stability	57
Figure 19. Schematic for the evolution of TRIMCyp residue 178.....	61
Figure 20. Coexpression of TRIMCyp does not diminish TRIM5 α restriction activity	68
Figure 21. Coexpression of TRIM5 α does not diminish TRIMCyp restriction activity	70

LIST OF TABLES

Table 1. Intraspecies polymorphisms in <i>M. sylvanus</i> TRIM5 α	35
Table 2. Interspecies comparison of predicted TRIM5 α amino acid sequence from <i>M. sylvanus</i> , <i>M. mulatta</i> , and <i>Papio cynocephalus anubis</i>	36
Table 3. Frequency of TRIMCyp-linked alleles in <i>M. fascicularis</i> populations.	51
Table 4. Polymorphisms in <i>M. fascicularis</i> TRIMCyp.	53

ACKNOWLEDGMENTS

I thank my advisor, Shiu-Lok Hu, for his incredible help and mentorship.

I thank my committee for valuable advice and discussion: Carlos Catalano, Adam Geballe, Michael Emerman, Jaisri Lingappa. Special thanks to Drs. Geballe and Lingappa for agreeing to be on my reading committee.

Thanks to my collaborators, Lisa Jones-Engel, Roger Wiseman, David O'Connor, Betsy Ferguson, and Summer Street, for providing samples and support and helping with analysis.

I thank Eric Shaw, John Cortes, Dale Lageua, and Damian Holmes of the Gibraltar Ornithological and Natural History Society and Mark Pizarro of the Gibraltar Veterinary Clinic for research permission and help with sample collection; Gregory Engel and Agustin Fuentes for help with sample collection; Alicia Wilbur for help with population genetic analyses; and Caitlin Burgess and James Ha for statistical consultation.

I thank the students who have worked with me on some of these projects. Kendan Jones-Isaac performed initial optimization of the *Nsil* restriction assay. Mayim Wiens helped to establish some of the TRIM5 α and TRIMCyp coexpressing cell lines. Paul Munson and Emily Darveau performed some of the cloning of *M. sylvanus* TRIM5 α .

Thanks to current and former members of the Hu Lab and Virology Core: Brad Cleveland, Deborah Diamond, Patricia Firpo, Wenjin Guo, On Ho, Maria Kahn, Andrea Kirmaier, Yun Li, Jennifer McKenna, Samantha Townsley, Modou Mbowe, Heather Mack, Xuebing Li, Bing Mei, Baoping Tian, Taryn Urion, and Ryan Wallerstedt. Particular thanks to Greg Brennan, who started the TRIM5 project in the Hu lab and taught me many of the assays used here.

Finally, I thank the administrative staff of the Department of Microbiology and the Hu Lab: Fiona Gibson, Sarah Mears, Maura Murphy, Betsy Stearman, and Janeth Talty.

CHAPTER 1. Introduction

RETROVIRAL RESTRICTION FACTORS

The AIDS pandemic resulted from the cross-species transmission of a retrovirus from chimpanzees to humans (Sharp and Hahn, 2011). Yet despite ongoing contact between humans and nonhuman primates, we have acquired very few of the retroviruses that are endemic in other primate species, and of these only HIV-1 is now pandemic in humans. Why are successful cross-species retroviral transmission events rare? How do organisms protect themselves from infection by retroviruses? One answer to these questions is found in retroviral restriction factors, which are host proteins that act as dominant genetic factors to restrict retroviral replication in certain species or cell types (Bieniasz, 2004; Goff, 2004; Neil and Bieniasz, 2009; Strebel et al., 2009; Zheng and Peterlin, 2005). Restriction factors are typically expressed constitutively in non-immune cell types and thus can act as an immediate defense against viral attack, acting even before the induction of innate immunity. For this reason, they have been described as comprising a third branch of the immune system known as intrinsic immunity (Bieniasz, 2004). However, just as the innate and adaptive immune systems are closely linked, restriction factors are intimately related to the innate immune system.

Understanding human restriction factors will help us to understand the selection pressures that have operated on HIV-1 and led to its current pandemic status. Similarly, understanding restriction factors in nonhuman primates and other model species will help us to develop better animal models for AIDS and eventually to develop vaccines and therapies.

Restriction factors can act at multiple stages of the retroviral life cycle (Figure 1). APOBEC3G is a cytidine deaminase that is packaged into the viral particle by producer cells and causes hypermutation of the viral genome during the reverse transcription step in target cells (Harris et al., 2003; Sheehy et al.,

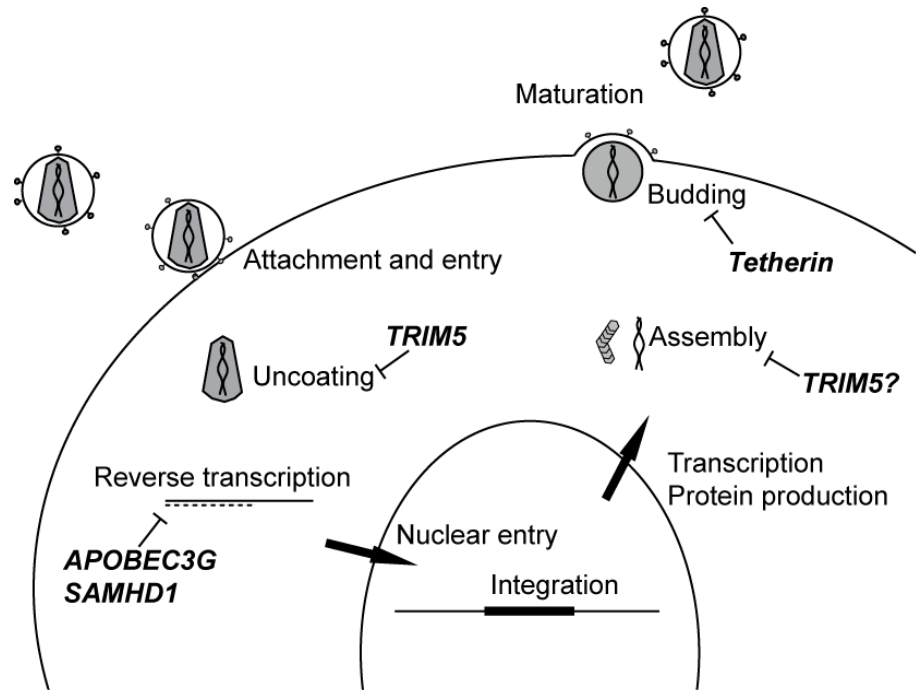

Figure 1. Restriction factors in the retroviral life cycle. Schematic of events in the retroviral life cycle, showing the stages at which restriction factors act. TRIM5 α and TRIMCyp act at the uncoating step and may also prevent assembly by causing degradation of Gag protein. APOBEC3G is packaged into the nascent viral particle (not shown) and causes hypermutation during reverse transcription in target cells. Tetherin prevents viral budding. SAMHD1 blocks viral replication at the reverse transcription step, possibly by sequestering nucleotides.

2002). Tetherin, also known as BST-2 or CD317, is a membrane-associated protein that is thought to physically tether budding viral particles to the membrane of the producer cell, limiting virion release (Neil et al., 2008). SAMHD1, which acts in myeloid cell types such as macrophages and dendritic cells, degrades free nucleotides, limiting reverse transcription (Goldstone et al., 2011; Hrecka et al., 2011; Laguette et al., 2011; Laguette and Benkirane, 2012; Powell et al., 2011).

Primate lentiviruses have evolved proteins that specifically counteract APOBEC3G, tetherin, and SAMHD1. The Vif protein targets APOBEC3G for proteasomal degradation. The Vpx gene of HIV-2 and SIV strains counteracts the activity of SAMHD1. HIV-1 does not have a Vpx gene, explaining its inefficient infection of myeloid cells. In most primate lentiviruses, the

Nef protein counteracts the activity of tetherin. However, human tetherin contains a deletion in the Nef-binding region; thus, HIV-1 uses the Vpu gene to counteract tetherin, while the envelope protein of HIV-2 has anti-tetherin properties (Jia et al., 2009; Le Tortorec and Neil, 2009; Lim et al., 2010b; Sauter et al., 2009; Yang et al., 2010). The existence of these varied mechanisms to counteract restriction factors suggests a long-term evolutionary arms race between viruses and their host species. The restriction factors themselves have signatures of adaptive evolution, suggesting their role in this arms race (Emerman and Malik, 2010).

One of the most interesting and best studied retroviral restriction factors is TRIM5 α . TRIM5 α targets the retroviral capsid at an early post-entry step. TRIM5 α restriction is not counteracted using a specific accessory gene, as for the restriction factors described above. Instead, mutations that change the sequence and conformation of the viral capsid can abrogate TRIM5 α binding. TRIM5 α is highly variable both within and among primate species, and has important consequences for the host specificity of primate lentiviruses.

ANTIRETROVIRAL ACTIVITY OF TRIM5 α

More than a decade ago, researchers found that the replication of N-tropic murine leukemia virus (N-MLV) is restricted in human cells, and named the putative restriction factor leading to this activity Ref1 (Towers et al., 2000). Meanwhile, independent research demonstrated a similar block to the replication of HIV-1 in nonhuman primate cells, which the researchers called Lv1 (Cowan et al., 2002). In both cases, the restriction occurs before reverse transcription and is saturable by increasing amounts of viral capsid. Although these two activities were described and named separately, they were subsequently traced to species-specific alleles of the TRIM5 α protein (Hatzioannou et al., 2004; Keckesova et al., 2004; Perron et al., 2004; Yap et al., 2004).

TRIM5 α is one of several splice variants expressed from the *TRIM5* gene, which belongs to the tripartite motif (TRIM) gene family (Reymond et al., 2001). TRIM proteins canonically contain, in order, a RING domain, one or two B-Box domains, and a coiled coil domain; these three domains are collectively known as the tripartite motif. The B-Box domain is unique to TRIM proteins and can be considered the defining feature of the family (Reymond et al., 2001).

This conserved domain structure is followed by any of a number of C-terminal domains. TRIM5 α contains a B30.2/SPRY

domain, which is the most common C-terminal domain

among TRIM proteins (Figure 2). *TRIM* genes encoding this

domain appear to form an evolutionary subgroup

(Sardiello et al., 2008).

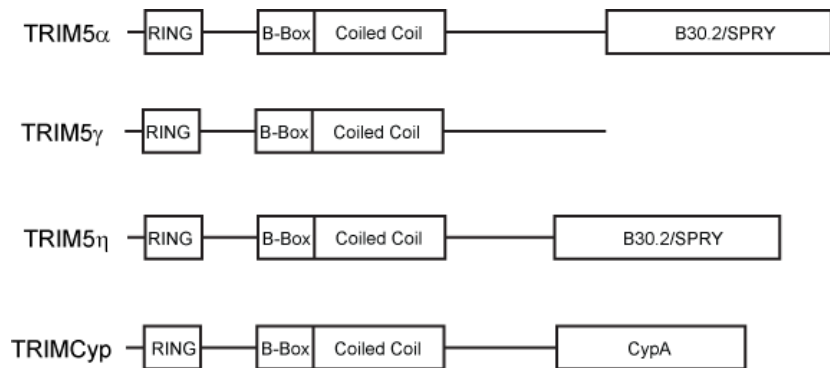

Figure 2. Domain structure of TRIM5 proteins showing TRIM5 α , TRIM5 γ , TRIM5 η , and macaque TRIMCyp.

TRIM5 α binds to the capsid of susceptible retroviruses via its B30.2/SPRY domain, and the sequence of this domain determines the viral specificity of a TRIM5 α isolate (Ohkura et al., 2006; Sawyer et al., 2005; Sebastian and Luban, 2005; Stremlau et al., 2006). Consistent with its role in determining viral specificity, the B30.2/SPRY domain has evolved under positive selection (Liu et al., 2005; Ortiz et al., 2006; Sawyer et al., 2005). In addition to extensive amino acid changes in specific variable regions that likely bind directly to viral capsids, certain lineages of both Old World and New World monkeys have undergone duplications in this region, leading to expanded antiviral specificity (Nakayama et al., 2005; Sawyer et al., 2005; Song et al., 2005a; Song et al., 2005b). In addition to positive selection, there is evidence for balancing selection on Old World monkey TRIM5 α . Several polymorphisms are shared across species, suggesting that

the maintenance of multiple alleles in a population may confer an evolutionary benefit (Newman et al., 2006).

The three domains of the tripartite motif are also required for restriction activity. The RING domain allows TRIM5 α to act as an E3 ubiquitin ligase, and specifically to autoubiquitinate (Diaz-Griffero et al., 2006; Yamauchi et al., 2008). However, it apparently does not target viral capsids for degradation via polyubiquitination (Javanbakht et al., 2005; Stremlau et al., 2006), and the function of the ubiquitination activity may depend on the specific host species and viral strain being targeted (Kim et al., 2011; Lienlaf et al., 2011; Maegawa et al., 2010). The ubiquitin ligase activity of TRIM5 α may be more relevant to its other activities that are independent of direct viral restriction (see below). The coiled coil domain mediates dimerization, which is thought to be required for efficient capsid binding (Javanbakht et al., 2006; Langelier et al., 2008). Some studies have found evidence of positive selection in the coiled coil domain, suggesting that it may also play a role in restriction specificity (Maillard et al., 2010; Sawyer et al., 2005). The B-Box domain mediates higher-order self-association, although other regions of the protein also participate in this self-association (Li and Sodroski, 2008; Li et al., 2011).

TRIM5 α dimers are thought to assemble into a hexagonal lattice that overlays the lattice structure of the viral capsid (Ganser-Pornillos et al., 2011). This interaction leads to disruption of the viral capsid and to premature uncoating (Black and Aiken, 2010; Zhao et al., 2011). TRIM5 α -mediated restriction typically occurs before reverse transcription. However, in the presence of proteasome inhibitors, reverse transcription products accumulate but restriction activity is maintained. This suggests that TRIM5 α restriction is a two-step process, with both proteasome-dependent and independent stages (Anderson et al., 2006; Wu et al., 2006). In the presence of proteasome inhibitors, TRIM5 α apparently sequesters viral capsids into cytoplasmic

bodies, suggesting that this sequestration is an intermediate in a pathway that ultimately leads to proteasomal degradation of the capsid (Campbell et al., 2008).

TRIM5 expression is upregulated by interferon signaling, connecting it with the innate immune system (Asaoka et al., 2005; Sakuma et al., 2007a; Carthagena et al., 2008). *TRIM5* is subject to alternative splicing, and multiple isoforms are found in all species that have been examined. Although TRIM5 α is the most abundant *TRIM5* isoform in human cell lines, it only constitutes approximately 50% of *TRIM5* cDNA derived from these cell lines (Battivelli et al., 2011a). Other isoforms, such as TRIM5 γ , δ , ι , and κ lack the B30.2/SPRY domain and thus the capsid-binding activity and restriction capability of TRIM5 α (See Figure 2) (Reymond et al., 2001; Stremlau et al., 2004). In some *in vitro* experiments, these other isoforms have a dominant negative effect on TRIM5 α antiviral activity (Battivelli et al., 2011a; Maegawa et al., 2008; Stremlau et al., 2004). However, their function *in vivo* is not well understood.

In addition to the early restriction of retroviruses by TRIM5 α , some researchers have described an additional restriction capability at a late stage of retroviral replication. Specifically, they found that the Gag polyprotein of HIV-1 is degraded in the presence of rhesus macaque TRIM5 α (Ohmine et al., 2011; Sakuma et al., 2007b). Another group found a similar, albeit weaker, effect of human TRIM5 α on HIV-1 (Zhang et al., 2010) However, this potential activity has been controversial, and its relevance to *in vivo* infection and disease is unclear (Zhang et al., 2008).

Although most studies on *TRIM5* have focused on its specific antiretroviral activity, an additional function in immune signaling has recently been described. TRIM30 α , which is one of several murine homologs of TRIM5 α , was found to negatively regulate NF- κ B activation downstream of toll-like receptor (TLR) signaling (Shi et al., 2008; Tareen et al., 2009). Shi *et al.* found that murine TRIM30 α negatively regulates TLR signaling by targeting TAB2 and TAB3 proteins for proteasomal degradation. These proteins are part of a complex that acts

downstream of TLR signaling to activate NF- κ B. Given that TRIM30 α is induced by TLR agonists, the authors speculate that it is a key component of a negative feedback loop to reduce innate immune activation (Shi et al., 2008).

Expression of human TRIM5 α , but not rhesus macaque TRIM5 α , also reduced TAB2 protein levels. However, human and rhesus macaque TRIM5 α resulted in the activation of NF- κ B-driven transcription, rather than the downregulation seen with murine TRIM30 α (Tareen et al., 2009). This seemingly paradoxical effect was explained when another group found that human TRIM5 α independently promotes activation of NF- κ B, as well as AP-1, another innate immune transcription factor, through the production of free K63-linked ubiquitin chains. These ubiquitin chains bind to TAB2/TAB3, leading to activation of downstream signaling (Pertel et al., 2011). This signaling activity of TRIM5 α occurred during retroviral infection, leading the authors to conclude that TRIM5 α acts as a pattern-recognition receptor for retroviral capsids. However, TRIM5 γ , which lacks the B30.2/SPRY domain, was also competent for signaling (Tareen et al., 2009), and TRIM5 α had signaling activity after interferon treatment in the absence of retroviral capsids (Pertel et al., 2011). Thus, TRIM5 proteins function in innate immune signaling in both retroviral capsid-dependent and independent ways.

TRIM5 α is present in most mammals, although it has not been extensively studied in species other than primates. Rabbits and hares, like primates, have a single *TRIM5* gene encoding a functional TRIM5 α (Fletcher et al., 2010; Sawyer et al., 2007; Schaller et al., 2007a). The *TRIM5* gene has been independently disrupted in both feline and canine lineages, and these species do not encode a functional TRIM5 α (McEwan et al., 2009). In contrast, the *TRIM5* locus has been expanded in rodents and cattle, with at least eight paralogs in mice, three in rats, and five in cattle (Sawyer et al., 2007; Si et al., 2006; Tareen et al., 2009; Ylinen et al., 2006). The multiple *TRIM5* paralogs in rodent species may also have expanded functional abilities (Shi et al., 2008; Tareen and Emerman, 2011; Taylor et al., 2011).

The *TRIM5* gene is under positive selection in primate lineages, suggesting that it has evolved under pressure to restrict viral replication (Liu et al., 2005; Ortiz et al., 2006; Sawyer et al., 2005). Although it is difficult to determine the specific viruses that TRIM5 α might have evolved to control, the foamy viruses are possible candidates. These viruses belong to the Spumaviridae, a distinct and unusual family of retroviruses found in most nonhuman primates (Yap et al., 2008). Among three species of New World monkeys with overlapping geographic ranges, the TRIM5 α protein from each species restricted the replication of foamy viruses endogenous to at least one of the other species. None of the species had a TRIM5 α protein that was able to restrict its own foamy virus. Thus, TRIM5 α restriction may contribute to the species specificity of foamy viruses (Pacheco et al., 2010). Other similar ecological interactions likely drive the evolution of *TRIM5* in various species.

HUMAN TRIM5 α AND HIV INFECTION

Human TRIM5 α , unlike that of many nonhuman primates, has limited restriction activity against HIV-1 infection. Rather, it has potent activity against gammaretroviruses such as MLV. Thus, the specificity of human TRIM5 α may have contributed to the emergence of HIV-1 and the AIDS pandemic. The lack of HIV-1 restriction by human TRIM5 α can be traced to a single amino acid substitution. Human TRIM5 α contains an arginine residue at position 332 in the B30.2/SPRY domain, whereas macaque TRIM5 α has a proline at this residue. Substitution of the proline residue in the human gene allows it to restrict HIV-1 (Li et al., 2006; Stremlau et al., 2005; Yap et al., 2005).

It is not clear what ancestral selective pressures drove the evolution of human TRIM5 α to its current form. Might an ancient epidemic gammaretrovirus have selected for the current specificity of human TRIM5 α ? Reconstruction of an endogenous gammaretrovirus found in chimpanzees but not in humans suggests that human TRIM5 α may have evolved to restrict this virus (Kaiser et al., 2007). However, a different reconstruction of the same ancestral virus was

insensitive to human TRIM5 α (Perez-Caballero et al., 2008). These findings remain controversial, and the past evolutionary pressures on human TRIM5 α may never be known in detail.

The relevance of human TRIM5 α to HIV-1 infection in the context of pandemic AIDS is unclear (Stremlau et al., 2005). There are several polymorphisms in the human *TRIM5* gene that may affect retroviral replication, as discussed below. However, no entirely consistent pattern has emerged from the several studies on the effects of human TRIM5 α on HIV-1 infection, and those studies that have found effects often find them in only one of several outcome measures. Thus, any effect of human TRIM5 α on HIV-1 infection is apparently small and is not clear-cut.

Two rare polymorphisms in human populations apparently lead to a truncated TRIM5 α protein. The deletion of a nucleotide leads to a frameshift at the C-terminal end of the RING domain in some Japanese individuals, while a nonsense mutation found in the Baka pygmies of Cameroon leads to a truncation early in the B30.2/SPRY domain (Nakajima et al., 2009; Torimiro et al., 2009). Both of these mutations would be expected to lead to a TRIM5 α protein that is nonfunctional for direct antiviral activity, although the form with the nonsense mutation may still be competent for signaling.

There are several more common *TRIM5* polymorphisms in various human populations. The H43Y polymorphism, found in the RING domain, has received a considerable amount of attention. This variant is most common in indigenous Central and South American populations but has been found in every cohort examined (Sawyer et al., 2006). The Y43 allele had impaired *in vitro* restriction activity against both HIV-1 and N-MLV in experiments conducted in canine or feline cell lines (Javanbakht et al., 2006; Sawyer et al., 2006). However, the change in HIV-1 restriction was not observed in independent experiments performed in HeLa cells, a human T cell line, or primary human CD4⁺ T cells (Goldschmidt et al., 2006; Nakayama et al., 2007;

Speelmon et al., 2006). Interpretation of these findings is challenging due to the already limited restriction activity of human TRIM5 α against HIV-1, which may explain the inconsistent results. Consistent with a detrimental effect on HIV-1 restriction, Y43 was associated with accelerated disease progression in a European cohort (van Manen et al., 2008). However, Y43 had no effect on various outcome measures in other studies (Nakayama et al., 2007; Price et al., 2010; Speelmon et al., 2006). In Chinese injecting drug users, Y43 was found more commonly in seronegative individuals relative to infected patients, possibly indicating a protective effect (Liu et al., 2011). Similar results were found in an Indian cohort, in which Y43 was more common in HIV-1 uninfected individuals than in infected individuals (Nakajima et al., 2009). This trend was also observed in Japanese patients, although it did not reach statistical significance in the Japanese cohort (Nakajima et al., 2009). Thus, the apparent detrimental effect of the H43Y polymorphism on restriction *in vitro* is not borne out by *in vivo* studies, and this allele may in fact be protective.

The R136Q polymorphism has also been extensively examined. This polymorphism improved restriction activity against HIV-1 in one *in vitro* study, but had no effect in two others (Goldschmidt et al., 2006; Javanbakht et al., 2006; Speelmon et al., 2006). In one epidemiological study, the Q136 allele was more common among HIV-1-infected subjects relative to exposed seronegative individuals, suggesting a detrimental effect (Speelmon et al., 2006). However, the opposite was seen in two other studies (Javanbakht et al., 2006; Price et al., 2010). An additional study found that individuals homozygous or heterozygous for the Q136 allele maintained low viral loads for a longer time after the development of CXCR4-using HIV-1 variants, suggesting a possible protective effect for this TRIM5 α allele late in infection (van Manen et al., 2008).

Several other polymorphisms have been associated with HIV-1 acquisition or disease progression in single studies, which have not been confirmed by other researchers.

Goldschmidt *et al.* found a modest association of G249D and H419Y variants with slower disease progression in a European cohort (Goldschmidt *et al.*, 2006). Nakajima *et al.* found that G110R was associated with reduced susceptibility to HIV-1 infection, although *in vitro* it slightly decreased the ability of chimeric TRIM5 α constructs to restrict both HIV-1 and HIV-2 (Nakajima *et al.*, 2009). Javanbakht *et al.* found two noncoding single nucleotide polymorphisms (SNPs) in the 5' untranslated region (UTR) that were elevated in uninfected individuals; they speculate that these polymorphisms may affect gene regulation or splicing (Javanbakht *et al.*, 2006).

TRIM5 α may have other effects on HIV-1 infection and disease that are not allele-specific. One study found that viral mutations that conferred escape from cytotoxic T lymphocyte responses also increased the sensitivity of these viral variants to human TRIM5 α , suggesting that TRIM5 α acts as a constraint on immune escape (Battivelli *et al.*, 2011b). Another study found that HIV-1 infected individuals had lower levels of TRIM5 α mRNA in their peripheral blood mononuclear cells before infection than did individuals who did not seroconvert (Sewram *et al.*, 2009). In a third study, putative TRIM5 α escape mutants were found in a minority of patients late in HIV-1 infection. These patients had a slower disease progression than those who did not develop these putative escape mutations, suggesting that TRIM5 α may have slowed their disease progression until the virus successfully escaped it (Kootstra *et al.*, 2007). Finally, HIV-2 patients infected with TRIM5 α -sensitive virus variants had lower viral loads than those with TRIM5 α -resistant virus variants (Onyango *et al.*, 2010). Together, these studies suggest a possible role for human TRIM5 α in HIV infection, although its role is probably relatively limited.

TRIM PROTEINS IN INNATE AND ANTIVIRAL IMMUNITY

TRIM5 is one of the best studied of the TRIM family of genes, a large and complex family with multiple functions. These genes, and the proteins they encode, are widely distributed throughout the animal kingdom (Sardiello *et al.*, 2008; van der Aa *et al.*, 2009). *TRIM* genes are variable among species, and are a frequent target for duplications and other genomic

rearrangements (Han et al., 2011; McEwan et al., 2009; Tareen et al., 2009). Many *TRIM* genes, including *TRIM5*, encode multiple protein isoforms through alternative splicing, further increasing the diversity of the *TRIM* family (Reymond et al., 2001).

Of the approximately 100 *TRIM* genes in the human genome, at least seven are not found in any other species, and there is at least one *TRIM* gene amplification that is polymorphic within the human population (Han et al., 2011). It is not clear whether these newly evolved *TRIM* genes have any function in human biology. However, other *TRIM* genes have been implicated in numerous biological processes. For instance, mutations in *TRIM* genes are associated with developmental disorders and cancers (Reymond et al., 2001; Sardiello et al., 2008).

Many *TRIM* proteins have functions in immunity and inflammation (Jefferies et al., 2011; McNab et al., 2011; Nisole et al., 2005; Ozato et al., 2008). A large subset of *TRIM* genes, including *TRIM5*, is upregulated by interferon treatment in both human and mouse cells (Carthagen et al., 2008; Rajsbaum et al., 2008). Many *TRIM* genes have also been implicated in autoimmune and inflammatory diseases (Jefferies et al., 2011). *TRIM20*, also known as pyrin or MEFV, is involved in familial Mediterranean fever, a hereditary inflammatory disease (Chae et al., 2009; Grandemange et al., 2011). *TRIM21*, also known as Ro52, is an autoantigen in systemic lupus erythematosus and is thought to downregulate the immune response under normal circumstances (Espinosa et al., 2009). *TRIM5*, 19, 20, 21, 22, 23, 25, 27, 40, and 56 are all implicated in the regulation of immune signaling pathways including the NF- κ B pathway, Toll-like receptor signaling, and interferon signaling (Gack et al., 2007; Gack et al., 2009; Jefferies et al., 2011; Pertel et al., 2011; Yu et al., 2011).

In addition to general roles in immunity and inflammation, a large subset of *TRIM* proteins has antiviral activity, and given the diversity of *TRIM* proteins, it seems likely that more remain to be discovered. These proteins can target any of a variety of virus families. A

screening study identified approximately 20 human TRIM proteins that inhibited either early or late stages of retroviral life cycles when overexpressed in human cells, although many of these remain to be substantiated and the mechanisms are not clear (Uchil et al., 2008). TRIM19, also known as PML, has been implicated in defense against a wide array of viruses, including retroviruses, herpesviruses, adenovirus, rhabdoviruses, lymphocytic choriomeningitis virus, influenza A virus, and poliovirus (Blondel et al., 2010; Geoffroy and Chelbi-Alix, 2011; Kentsis et al., 2001; Maroui et al., 2011; Regad et al., 2001; Reichelt et al., 2011; Turelli et al., 2001). Among other TRIM proteins, TRIM28 mediates silencing of murine leukemia virus in embryonic cells (Wolf and Goff, 2007; Wolf et al., 2008). TRIM79 α , a murine-specific protein, targets the RNA polymerase of certain flaviviruses for lysosomal degradation (Taylor et al., 2011). TRIM22 inhibits HIV particle production (Barr et al., 2008). TRIM21 mediates intracellular antibody-mediated antiviral immunity (Mallery et al., 2010). Thus, the antiviral and inflammatory functions of TRIM5 are not unique, or even unusual, within its gene family. It seems likely that further functions of *TRIM* genes in immunity remain to be discovered, and that studies of these genes will continue to improve our understanding of antiviral immunity in the future.

EVOLUTION AND GENETIC STRUCTURE OF TRIMCYP

The peptidyl prolyl isomerase cyclophilin A (CypA) binds the capsids of HIV-1 and other lentiviruses (Lin and Emerman, 2006; Luban et al., 1993). This protein has numerous effects, both positive and negative, on retroviral replication, depending on the specific virus and cell type (Berthoux et al., 2005; Lin and Emerman, 2006; Luban, 2007; Matsuoka et al., 2009; Sawyer et al., 2007; Sokolskaja et al., 2006; Stremlau et al., 2006). Inhibition of CypA activity by the drug cyclosporin A (CsA) disrupts the replication of HIV-1 in human cell lines (Luban, 2007; Sayah and Luban, 2004). However, CsA treatment dramatically improves HIV-1 replication in cells derived from owl monkeys (the *Aotus* genus of New World monkeys). These data were explained when researchers found that a retrotransposition event has inserted a *CypA* cDNA

into an intron of the *Aotus TRIM5* gene (Nisole et al., 2004; Sayah et al., 2004). The resulting fusion protein, known as TRIMCyp, contains a CypA domain in place of the B30.2/SPRY domain. TRIMCyp has antiretroviral activity similar to that of TRIM5 α , but with its specificity determined by the capsid-binding specificity of CypA rather than that of the B30.2/SPRY domain. Thus, the antiviral activity of TRIMCyp is abrogated by CsA, which prevents CypA binding to the viral capsid.

This insertion is unique to *Aotus* species and apparently fixed within all members of the genus. *Aotus* species diverged from other New World monkeys approximately 22 million years before present (ybp), while the different *Aotus* species diverged approximately 4.5 million ybp. Thus, TRIMCyp must have evolved in New World monkeys between 4.5 and 22 million ybp (Ribeiro et al., 2005).

An independent retrotransposition of *CypA* in the 3' UTR of the *TRIM5* gene has generated a remarkably similar TRIMCyp in macaques, which are Old World monkeys belonging to the genus *Macaca* (Brennan et al., 2008; Liao et al., 2007; Newman et al., 2008; Virgen et al., 2008; Wilson et al., 2008b). In these animals, the presence of the *CypA* insertion is correlated with a polymorphism at the exon 7 splice acceptor site, in which the canonical AG dinucleotide splice acceptor is changed to an AT dinucleotide. This change leads to the production of at least three alternatively spliced products. In TRIM5 θ , the AG dinucleotide that comprises the first two nucleotides of exon 7 is used as a splice acceptor. This two-nucleotide deletion in the coding sequence causes a frameshift and a truncated protein. In TRIM5 η , exon 7 is skipped entirely, and exon 6 is spliced directly to exon 8. The absence of exon 7 leads to an in-frame deletion of nine amino acids in the linker 2 region between the coiled coil and B30.2/SPRY domains (see Figure 2). Interestingly, TRIM5 η has no antiviral activity that has been discovered so far, suggesting that the linker 2 region is important for the structure and antiviral function of TRIM5 α (Brennan et al., 2007; Brennan et al., 2008).

The final alternative splice form related to the presence of the AT dinucleotide is TRIMCyp, which results from the skipping of exons 7 and 8 and splicing to the beginning of the *CypA* insertion (Brennan et al., 2008; Virgen et al., 2008; Wilson et al., 2008b). Unlike *Aotus* TRIMCyp, which binds to and restricts HIV-1, the TRIMCyp from rhesus macaques (*M. mulatta*) and pigtail macaques (*M. nemestrina*) restricts HIV-2 but not HIV-1. The capsid of HIV-2 only weakly binds to wild-type CypA (Price et al., 2009). However, two mutations in the *CypA* sequence of *M. mulatta* and *M. nemestrina* TRIMCyp allow for specific binding to the HIV-2 capsid (Virgen et al., 2008; Price et al., 2009; Caines et al., 2012). These mutations are D369N and R372H in the TRIMCyp protein (also sometimes defined by their as residues 66 and 69 within the CypA domain). In the context of *M. mulatta* TRIMCyp, R372H improves the affinity of the protein for the HIV-2 capsid, while D369N destroys affinity for HIV-1 (Price et al., 2009).

The restriction specificity of TRIMCyp in both New World and Old World monkeys is determined by the viral capsid binding specificity of the CypA domain, much as the specificity of TRIM5 α is determined by the capsid binding specificity of the B30.2/SPRY domain. In support of this idea, artificial fusion of CypA to the tripartite motif region of human or feline *TRIM5*, or even of other TRIM proteins such as TRIM19, leads to a functional antiviral restriction factor (Dietrich et al., 2011b; Dietrich et al., 2010b; Neagu et al., 2009; Yap et al., 2006). Fusion of CypA to an unrelated murine restriction factor or even to multimerization domains not otherwise implicated in antiviral defense can also lead to viral restriction, suggesting that at least part of the antiviral activity of TRIMCyp results from its ability to bind to the viral capsid and to multimerize (Javanbakht et al., 2007; Schaller et al., 2007b; Yap et al., 2007).

As mentioned above, TRIM5 proteins homodimerize through their coiled-coil domains (Javanbakht et al., 2006; Langelier et al., 2008). Because all TRIM5 splice forms, including TRIMCyp, share the same coiled-coil domain, they may also be able to heterodimerize. Indirect evidence suggests that such heterodimerization may have important functional consequences.

When *M. mulatta* TRIMCyp is overexpressed in TRIMCyp-negative *M. mulatta* cells, the TRIM5 α -mediated restriction of HIV-1 is reduced. Thus, TRIMCyp may have a dominant-negative effect on TRIM5 α (Wilson et al., 2008b). These data suggest that TRIM5 α and TRIMCyp likely interact. However, interpretation of these results is complicated by the artificial system in which they were obtained. In the unrelated but mechanistically similar murine restriction factor Fv1, overexpression of one allele relative to the other leads to an apparent dominant negative effect, when the two alleles are codominant *in vivo* (Bock et al., 2000). Thus, the effect of coexpression of different TRIM5 proteins remains an open question and is one of the aims addressed in this work (see Chapter 5).

MACAQUE EVOLUTION AND ANIMAL MODELS FOR AIDS

Infection of macaques with SIV or related chimeric viruses is commonly used as a model of HIV infection in humans. The three macaque species commonly used as models for biomedical research are *M. mulatta* (rhesus macaques), *M. fascicularis* (cynomolgous macaques), and *M. nemestrina* (pigtail macaques). All three of these species have TRIMCyp at some proportion in their populations. The genetic changes in *TRIM5* leading to TRIMCyp expression appears to be fixed in *M. nemestrina*, and this species does not express TRIM5 α (Brennan et al., 2007; Brennan et al., 2008; Kuang et al., 2009; Newman et al., 2008). In *M. mulatta*, TRIMCyp is relatively rare, and appears to be present in animals of Indian, but not Chinese, origin (Newman et al., 2008; Wilson et al., 2008b). The prevalence of TRIMCyp in *M. fascicularis* had not previously been described, and its determination was one of the aims of this work (Dietrich et al., 2011a; see Chapter 4).

Macaques belong to the genus *Macaca*, in the family Cercopithecidae of Old World monkeys (Figure 3). The natural range of all macaque species, with the exception of *M. sylvanus*, is in Asia. *M. sylvanus* is found in North Africa and Gibraltar and diverged from the Asian macaques approximately 5-6 million years ago. The Asian macaques are divided into

three clades, known as the *silenus* group, the *fascicularis* group, and the *sinica* group. These groups are defined by morphological characteristics as well as molecular phylogeny (Li et al., 2009; Tosi et al., 2003). *M. mulatta* and *M. fascicularis* are closely related members of the *fascicularis* group, while *M. nemestrina* is more distantly related and belongs to the *silenus* group. These three species have overlapping native ranges in Southeast Asia.

The first AIDS models in macaques used infection with SIVmac. SIVmac is derived from SIVsm, which naturally infects sooty mangabeys. These viruses are relatively distantly related to

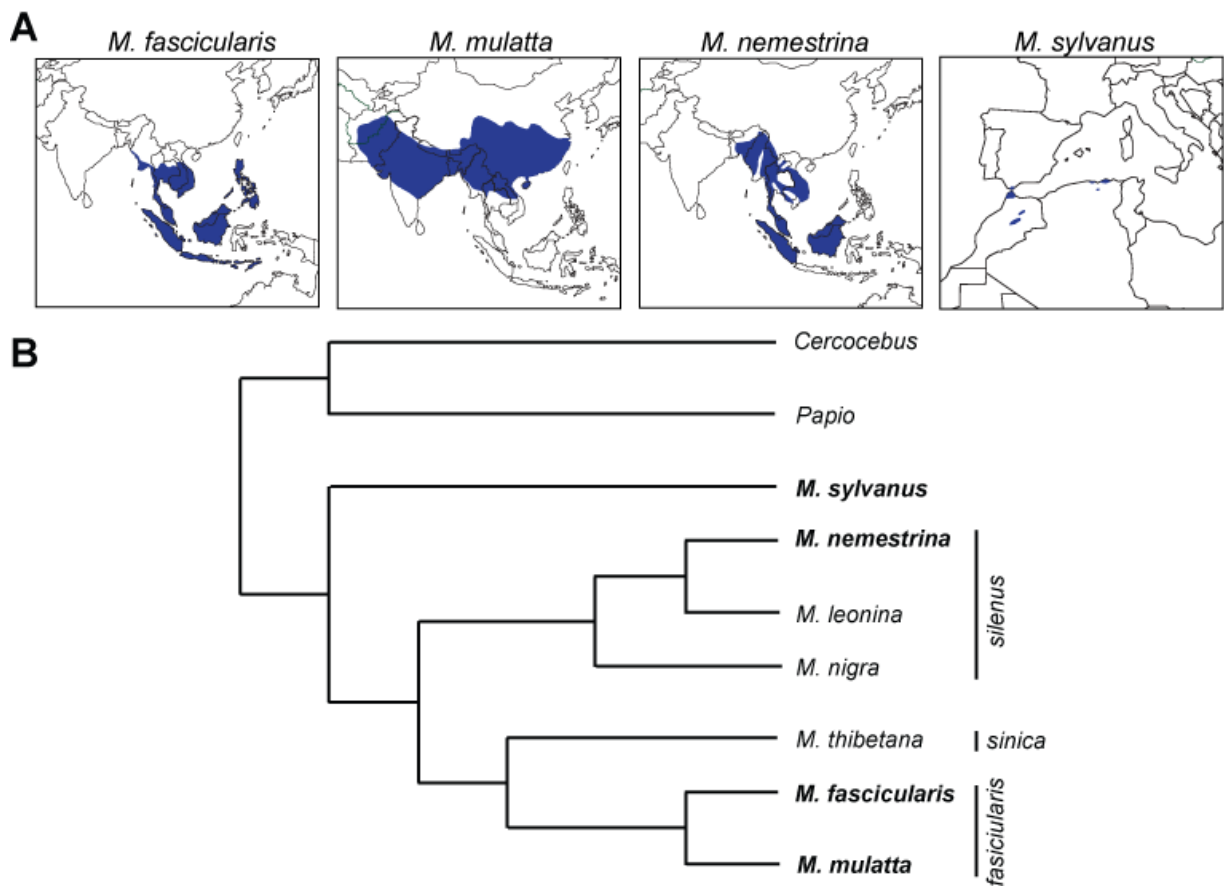

Figure 3. Geographic distribution and phylogenetic relationships of selected Old World primate species. (A) The geographic ranges of *M. fascicularis*, *M. mulatta*, *M. nemestrina*, and *M. sylvanus* are highlighted in blue. (B) Schematic dendrogram showing the phylogenetic relationships between macaque species, *Papio* (baboons), and *Cercocebus* (mangabeys). Asian macaque phylogenetic groups are indicated at right (Li et al., 2009). This graphical representation is not to scale and is not intended to reflect relative divergence. Relationships are adapted from Li et al., 2009; Page et al., 1999; and Tosi et al., 2003.

HIV-1, which is derived from SIVcpz. SIVcpz is found in chimpanzees and is itself a recombinant virus derived from the SIVs of red-capped mangabeys (*Cercocebus torquatus*) and those infecting various *Cercopithecus* species (Sharp and Hahn, 2011). HIV-1 and SIVmac have different accessory genes, which affects their susceptibility to restriction factors, as described above (Figure 4). Epitopes targeted in HIV-1 vaccine candidates may not be present in SIVmac, and many of the therapeutic agents used against HIV-1 are not active against SIVmac.

Because of these challenges, researchers have developed recombinant viruses, known as SHIV. SHIV strains contain the HIV envelope or reverse transcriptase, along with various accessory genes, within the backbone of SIVmac (Ambrose et al., 2007; Baroncelli et al., 2008). These constructs allow testing of envelope-based vaccines or reverse transcriptase inhibitors. However, SHIV constructs are not useful for testing vaccines that target HIV-1 epitopes not contained in the SHIV strain, or drugs that target proteins other than the reverse transcriptase.

Therefore, a new generation of chimeric viruses that can infect macaques has recently been described. These constructs, known as HSIV or simian-tropic HIV-1 (stHIV-1), are designed to evade host restriction factors. Specifically, these constructs contain the Vif gene from SIVmac in the background of HIV-1, allowing the virus to counteract simian APOBEC3G.

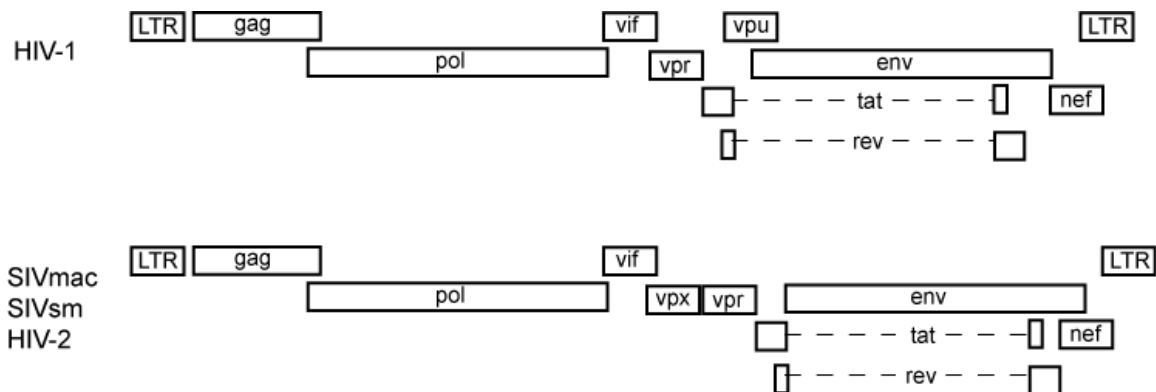

Figure 4. Genome structures of selected primate lentiviruses.

TRIM5 α -mediated restriction can be avoided by using these constructs to infect *M. nemestrina*, which does not have TRIM5 α and has a TRIMCyp protein that does not restrict HIV-1. Although HSIV/stHIV-1 viruses are still imperfect models of HIV/AIDS and do not replicate as well as SIV models in macaques, these studies show that animal models of HIV/AIDS have been directly improved by our understanding of restriction factor function (Hatzioannou et al., 2009; Igarashi et al., 2007; Saito et al., 2011; Thippeshappa et al., 2011). Future work will doubtless improve these models, perhaps by evading tetherin-mediated restriction.

Recently, it has become clear that TRIM5/TRIMCyp proteins have important consequences for the outcome of SIV infection of macaques. In addition to TRIMCyp, rhesus macaques have two major alleles of TRIM5 α , which differ at positions 339-341 in the B30.2/SPRY domain. One allele contains amino acid residues TFP at those positions, and can restrict SIVsm, as can rhesus macaque TRIMCyp. The other TRIM5 α allele contains a Q residue, with a two amino acid deletion; this allele does not restrict SIVsm (Kirmaier et al., 2010; Newman et al., 2006; Wilson et al., 2008a). Kirmaier *et al.* showed that animals homozygous for the nonrestrictive TRIM5 α allele have significantly higher viral loads when infected with SIVsm than animals that have two copies of a restrictive allele; heterozygotes had an intermediate phenotype (Kirmaier et al., 2010). They further showed that several amino acid residues found in SIVmac can evade restriction by TRIMCyp and by the TFP allele of rhesus macaque TRIM5 α . They speculate that these residues evolved to evade TRIM5 proteins when the ancestor of SIVmac was transmitted to rhesus macaques. *TRIM5* genotype also has an effect on mucosal acquisition of SIVsm in rhesus macaques (Yeh et al., 2011). *TRIM5* alleles may also affect the acquisition or control of SIVmac strains in rhesus macaques, although this effect is less dramatic than the effect on SIVsm and appears to depend on the virus strain and/or route of transmission (de Groot et al., 2011; Fenizia et al., 2011; Letvin et al., 2011; Lim et al., 2010b; Lim et al., 2010c).

In this work, I address several critical questions about TRIM5 α and TRIMCyp in Old World primates. When in the evolution of Old World primates did TRIMCyp arise, and what is its distribution within existing species? Among species used as AIDS models, *M. fascicularis* has not previously been thoroughly examined for its restriction capability. How common is TRIMCyp within different populations of *M. fascicularis*, and what is its restriction specificity? Finally, what is the effect of coexpressing TRIM5 α and TRIMCyp in the same cells? All these questions have important implications for animal models of AIDS, and further exploration of these topics will doubtless lead to important insights.

CHAPTER 2. Materials and Methods

Samples

Peripheral blood (maximum of 10 ml/kg/week) from unrelated *P. cynocephalus anubis* and *M. fascicularis* animals housed at the Washington National Primate Research Center (WaNPRC) was collected in heparinized Vacutainer tubes. *M. sylvanus* were captured from wild populations in Gibraltar, and blood was collected in EDTA-coated Vacutainer tubes. Blood was collected by venipuncture when animals were under sedation (ketamine 10-15 mg/kg) to relieve pain and suffering. DNA was isolated using a QIAamp DNA Blood Mini kit (Qiagen) on fresh whole blood. RNA was isolated using a QIAamp RNA Blood Mini kit (Qiagen) on fresh whole blood (*P. cynocephalus anubis* and *M. fascicularis*) or frozen leukocyte pellets preserved using RNeasy (Qiagen) (*M. sylvanus*).

Blood samples from 16 *M. fascicularis* were obtained from Alpha Genesis, Inc., including 4 each derived from Indochina (2 Vietnam, 2 Cambodia), Indonesia, Mauritius and the Philippines. Five additional Indonesian and ten additional Indochinese samples were obtained from different breeders, to ensure that animals were unrelated. DNAs were extracted using a MagnSil Genomic DNA Extraction procedure (Promega, Inc.) and the animal ancestries were confirmed by a 66 SNP assay developed to distinguish macaque ancestry (Street et al., 2007). The SNP assay also verified each animal to be unique.

Genomic DNAs from 40 feral Mauritian-origin *M. fascicularis* housed at the Wisconsin National Primate Research Center (WNPRC) were purified from 2ml EDTA peripheral blood samples using a MagNA Pure LC DNA Isolation kit (Roche).

DNA samples were obtained from the Coriell Institute Integrated Primate Biomaterials and Information Resource (IPBIR) for *M. nigra* (Repository number PR00726), *M. thibetana* (PR00711), and *P. hamadryas* (PR00559).

All animals were cared for according to the regulations and guidelines of the Institutional Animal Care and Use Committees at their respective institutions.

Cell lines

293T cells were grown in DMEM containing 10% fetal bovine serum. CrFK cells were grown in DMEM containing 8% bovine growth serum, supplemented with 0.4 µg/ml puromycin(Sigma) and/or 800 µg/ml G418 (Promega) as appropriate.

PCR and Restriction Analysis

For the *NsiI* restriction assay, genomic DNA was amplified using Platinum PCR Supermix High Fidelity (Invitrogen), with forward primer MfaT5ex6F (Primer 2; ATC TGA AAC GAA TGC TAG ACA TG) and reverse primer 3TmNotI (Primer 4; ATC TAG GCG GCC GCT TAA GAG CTT GGT GAG CAC AGA GTC ATG). PCR products were digested using FastDigest *NsiI* enzyme (Fermentas) (Newman et al., 2006).

To test for the *CypA* insertion, genomic DNA was PCR amplified using Platinum PCR Supermix High Fidelity (Invitrogen), with forward primer 3UTRF (Primer 3; TGA CTC TGT GCT CAC CAA GCT CTT G) and reverse primer 3UTRRLong (Primer 6; TCA CCC TAC TAT GCA ATA AAA CAT TAG GAC), as described by Wilson *et al.* (Wilson et al., 2008b). *CypA*-containing PCR products were cloned and sequenced (at least two clones per animal).

For RT-PCR, *M. fascicularis* TRIMCyp RNA was reverse transcribed and PCR amplified using a SuperScript III One-Step RT-PCR kit (Invitrogen), with forward primer XhoIHATRIM5 (Primer 1; CTA GAT CTC GAG ATG TAC CCA TAT GAC GTT CCA GAC TAC GCG GCT TCT GGA ATC CTG GTT AAT GTA AAG) and reverse primer CypARMCSNotI (Primer 5; GTA TAT GCG GCC GCT TAT TCG AGT TGT CCA CAG TCA G). *M. sylvanus* TRIM5α first-strand cDNA was produced using the Accuscript High Fidelity 1st Strand cDNA Synthesis Kit (Stratagene), using random hexamers as primers, and the cDNA was PCR amplified using primers 1 and 4 with AccuPrime Pfx Supermix (Invitrogen).

To confirm cDNA sequences, genomic DNA was amplified in two segments due to the length of intron 4. Exons 2-4 were amplified using forward primer XhoI/TRIM5 (CTA GAT CTC GAG ATG GCT TCT GGA ATC CTG GTT AAT GTA AAG) and reverse primer MfaT5int4R (CAG CAA CTG ATT CAG AAA AGC GGT CC). Exons 5-6 were amplified using forward primer MfaT5int4F (CAC TGT CAC CAT CTC CAT TCT CAG CAC) and reverse primer MfaT5int6R (CCC ATC AGC AGC AGA CAA TAT CCA). Two clones from each animal were sequenced.

Brightness and contrast were adjusted in gel photos using Adobe Photoshop CS4 software. All adjustments were made across entire images.

Cloning

PCR products for sequencing were cloned using a StrataClone Blunt PCR Cloning Kit (Stratagene). Sequencing was performed by the University of Washington Biochemistry Sequencing Center or the University of Washington Pharmaceutics Sequencing Center.

For stable transduction of cell lines, RT-PCR products were cloned using a StrataClone PCR cloning kit or a StrataClone Blunt PCR Cloning Kit (Stratagene). The resulting plasmids containing HA-tagged TRIMCyp were digested using *XhoI* and *NotI* restriction enzymes (New England Biolabs). The excised TRIMCyp bands were subcloned into the pLPCX or pLNCX2 retroviral expression vectors (Clontech).

TRIMCyp-containing pLPCX plasmids were mutagenized using a QuikChange II XL site-directed mutagenesis kit (Stratagene).

Sequence Analysis

Sequence analysis was performed using Geneious 4.8 (Drummond et al., 2009) and MEGA software (Tamura et al., 2007; Tamura et al., 2011). Sequences were aligned for a 1204 bp genomic region of *TRIM5* encompassing exons 7 and 8 and introns 6 and 7 (amplified using primers 2 and 4). Novel sequences were aligned with sequences from *M. mulatta* (extracted from chromosome 14 of the rhesus macaque genome, NC_007871.1), *M. nemestrina*

(EU371641.1), and *Homo sapiens* (extracted from chromosome 11 of build 37.1 of the human genome, NT_009327.18) obtained from GenBank. Phylogenetic trees were generated in Geneious or MEGA 5 using neighbor-joining or maximum likelihood algorithms with 1000 bootstrap replicates. The human sequence was used as an outgroup.

MEGA4.0 software was used to detect departures from neutrality with Tajima's *D* statistic (Tajima, 1989). Positions containing gaps and missing data were deleted.

Sequences generated in this work were deposited in GenBank (Accession numbers HM468429- HM468446, HQ834751-HQ834786 and HQ840753-HQ840761).

Production of stable TRIM5 α and TRIMCyp-expressing cell lines

293T cells were co-transfected using linear polyethylenimine with plasmids expressing VSV-G envelope protein (pL-VSV-G), MLV Gag-Pol backbone (mGP), and pLPCX or pLNCX plasmids containing HA-tagged *M. fascicularis* TRIMCyp (Reed et al., 2006). Supernatants were harvested after 48 hours. CrFK cells in 6-well plates were transduced with 1 mL of virus-containing supernatant and spinoculated for 1 hour at 650 \times *g*. Cells were then allowed to grow to confluence before beginning selection with 6 μ g/mL puromycin or 800 μ g/ml G418. For coexpression, puromycin-resistant cells expressing TRIM5 α were established, and then re-transduced with TRIMCyp constructs in pLNCX.

For immunoblotting, cells were lysed in M-PER Mammalian Protein Extraction reagent (Thermo Scientific). HA-tagged proteins were bound with HA.11 monoclonal antibody (Covance) and detected with a goat anti-mouse alkaline phosphatase-conjugated secondary antibody (Sigma-Aldrich). Western blot films were scanned, and brightness and contrast were adjusted using Adobe Photoshop CS4 software. All adjustments were made across entire images.

Pseudotyped virus production

293T cells were cotransfected with VSV-G envelope protein and envelope-negative, GFP-expressing virus backbones (HIV-1 pNL4-3, HIV-2 ROD, SIVmac239, and FIV) using linear polyethylenimine (Reed et al., 2006). In the case of FIV, the packaging plasmid pGinSin was also cotransfected. Virus-containing supernatant was harvested after 48 hours and concentrated using PEG-It (System Biosciences). Reverse transcriptase in viral preparations was quantified using a colorimetric reverse transcriptase assay (Roche).

Infectivity assay

CrFK cells, and CrFK-derived cells expressing TRIM5 proteins, were seeded and grown overnight in 6-well plates with nonselective medium. They were then infected with dilutions of virus in DMEM containing 5 µg/mL polybrene. For initial testing of *M. fascicularis* TRIMCyp-expressing cell lines, viral inocula were normalized by RT concentration using a colorimetric RT assay kit (Roche). In subsequent experiments, inocula were normalized by infectivity on CrFK cells.

After 2 hours, the medium was replaced with fresh growth medium, and the cells were grown for an additional 48 hours. GFP-expressing cells were enumerated by flow cytometry on a FACSCalibur (Becton Dickinson), and data were analyzed with FlowJo 7.1.3 software (Tree Star, Inc.). Normalized percent infectivity was calculated relative to CrFK cells.

CHAPTER 3. Evolution of the Antiretroviral Restriction Factor TRIMCyp in Old World Primates

ABSTRACT

The retroviral restriction factor TRIMCyp, which is a fusion protein derived from the *TRIM5* gene, blocks replication at a post-entry step. Among Old World primates, TRIMCyp has been found in four species of Asian macaques, but not in African monkeys. To further define the evolutionary origin of Old World TRIMCyp, we examined two species of baboons (genus *Papio*) and three additional macaque species, including *M. sylvanus*, which is the only macaque species found outside Asia, and represents the earliest diverging branch of the macaque lineage. None of four *P. cynocephalus anubis*, one *P. hamadryas*, and 36 *M. sylvanus* had either TRIMCyp mRNA or the genetic features required for its expression. *M. sylvanus* genomic sequences indicated that the lack of TRIMCyp in this species was not due to genetic homogeneity among specimens studied and revealed the existence of four TRIM5 α alleles, all distinct from *M. mulatta* and *Papio* counterparts. One of the polymorphisms in *M. sylvanus* TRIM5 α , T339M, led to differences in restriction activity against HIV-2 ROD and SIVsm. Together with existing data on macaque evolution, our findings indicate that TRIMCyp evolved in the ancestors of Asian macaques approximately 5-6 million years before present (ybp), likely as a result of a retroviral threat. TRIMCyp then became fixed in the *M. nemestrina* lineage after it diverged from *M. nigra*, approximately 2 million ybp. The macaque lineage is unique among primates studied so far due to the presence and diversity of both TRIM5 and TRIMCyp restriction factors. Studies of these proteins may provide valuable information about natural antiviral mechanisms, and give further insight into the factors that shaped the evolution of macaque species.

INTRODUCTION

Primates have been infected with retroviruses frequently throughout their evolution. Retroviral infections are believed to have driven the evolution of host factors such as the restriction factors TRIM5 α and TRIMCyp (Emerman and Malik, 2010). These restriction factors specifically inhibit retroviral replication (Hatzioannou et al., 2004; Keckesova et al., 2004; Stremlau et al., 2004; Stremlau et al., 2006), and bear the marks of previous evolutionary conflicts (Newman et al., 2006; Sawyer et al., 2005).

TRIM5 α and TRIMCyp are two of several alternatively spliced isoforms of the *TRIM5* gene (Reymond et al., 2001). This gene belongs to the tripartite motif (*TRIM*) gene family, of which several members in addition to *TRIM5* have been implicated in immune responses to pathogens (Ozato et al., 2008). TRIM proteins contain, in order, a RING domain, one or two B-Box domains, and a coiled coil domain. TRIM5 α also has a C-terminal B30.2/SPRY domain, which recognizes and binds to the capsids of susceptible retroviruses, leading to post-entry restriction of infection (Diaz-Griffero et al., 2009; Javanbakht et al., 2006; Reymond et al., 2001). This restriction occurs in a two-stage process, with stages both before and after reverse transcription (Stremlau et al., 2004; Stremlau et al., 2006; Wu et al., 2006).

In a striking instance of convergent evolution, cyclophilin A (*CypA*) sequences have been inserted into the *TRIM5* gene by independent retrotransposition events in both New World (*Aotus*/owl monkey) and Old World (*Macaca*/macaque) primate lineages. Alternative splicing to these sequences leads to the production of TRIMCyp, in which the B30.2/SPRY domain of TRIM5 α is replaced with a *CypA* domain. Because *CypA*, like the B30.2/SPRY domain, can bind to retroviral capsids, TRIMCyp also has antiretroviral activity (Nisole et al., 2004; Sayah et al., 2004). New World and Old World TRIMCyp proteins have distinct antiretroviral specificities, which also differ from that of TRIM5 α (Brennan et al., 2008; Liao et al., 2007; Virgen et al., 2008; Wilson et al., 2008b).

In macaques, the retrotransposed *CypA* sequence required for TRIMCyp production is found in the 3' untranslated region (UTR) of the *TRIM5* gene. TRIMCyp expression and the presence of this *CypA* insertion are correlated with a single nucleotide polymorphism (SNP) at the exon 7 splice acceptor site, in which the canonical AG dinucleotide splice acceptor is changed to AT (Brennan et al., 2007). This change leads to the production of alternatively spliced products including TRIMCyp, which results from skipping of exons 7 and 8 and splicing to the *CypA* insertion (Figure 5) (Brennan et al., 2007; Brennan et al., 2008; Liao et al., 2007; Virgen et al., 2008; Wilson et al., 2008b).

TRIMCyp, and the splice acceptor SNP and *CypA* insertion required for its expression, have been found in all four species of Asian macaques that have been tested so far. In these four species, *Macaca nemestrina*, *M. leonina*, *M. mulatta*, and *M. fascicularis*, the genetic

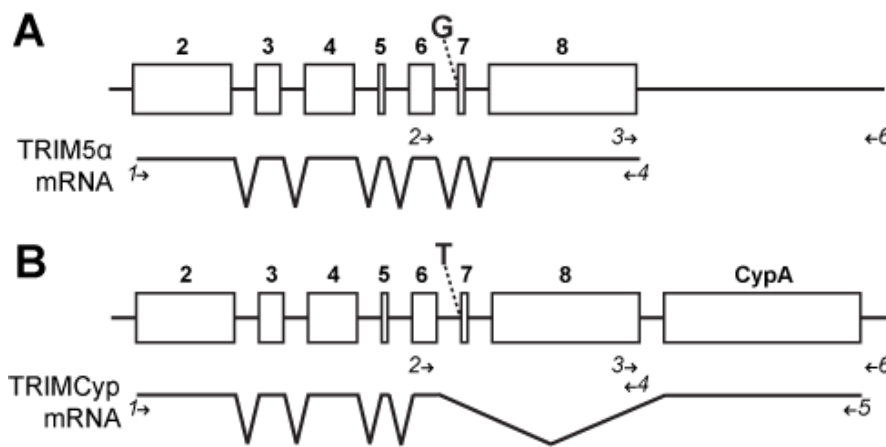

Figure 5. Genomic organization and mRNA splicing of *TRIM5* alleles. (A) DNA sequence of the *TRIM5α*-expressing allele is shown schematically on top, with open boxes representing exons 2-8 numbered in bold. The mRNA splicing pattern indicated below. The canonical splice acceptor sequence with a G nucleotide upstream of exon 7 is as indicated. (B) The *CypA* insertion in the *TRIMCyp*-expressing allele is located as indicated. A SNP (T) at the exon 7 splice acceptor allows the splicing of exon 6 to the coding region of the *CypA* insertion. Minor splice isoforms in both alleles are not depicted. Primers used for analyses described in subsequent figures and text are depicted as arrows and numbered in italics. Primers used for genomic analysis are shown above the mRNA diagram, and those for RT-PCR analysis shown below. Primer 4 was used for both analyses.

changes are found at varying frequencies. They appear to be fixed in *M. nemestrina* and the closely related *M. leonina* (Brennan et al., 2007; Brennan et al., 2008; Kuang et al., 2009; Newman et al., 2008). In *M. mulatta*, *TRIMCyp* is present in animals of Indian origin at an allele frequency of approximately 25%. It

has not been found in Chinese *M. mulatta*, among at least 76 individuals that have been screened (Newman et al., 2008; Wilson et al., 2008b).

Phylogenetically, *M. mulatta* and *M. fascicularis* belong to the *fascicularis* group of Asian macaques. *M. nemestrina* and *M. leonina* belong to the earliest diverging group, the *silenus* group (Li et al., 2009; Ziegler et al., 2007; see Figure 3). Thus, TRIMCyp is present in maximally divergent groups within the Asian macaques, and was likely present in the ancestor of all Asian macaques. TRIMCyp was not found in sooty mangabeys (*Cercocebus atys*), the only other Old World monkey species that has been tested (Newman et al., 2008). This African monkey species, along with baboons (genus *Papio*), belongs to the papionin clade, a sister clade to the macaques. However, the absence of TRIMCyp in sooty mangabeys does not necessarily imply that it is absent in the papionin clade as a whole, because at least one Asian macaque lineage (Chinese *M. mulatta*) also appears to lack TRIMCyp. Therefore, studies of additional Old World primate species are necessary to help establish the evolutionary origin of TRIMCyp.

M. sylvanus, the only African macaque, has a unique position within the macaque lineage. This species diverged from the Asian macaques after the macaques diverged from the papionin clade, making it the most closely related outgroup to the Asian macaques. Thus, study of *M. sylvanus* will help to determine whether TRIMCyp evolved before or after the divergence of African from Asian macaques.

In this study, we tested *M. sylvanus*, two baboon species, and two additional Asian macaques, *M. nigra* and *M. thibetana*, for TRIMCyp. We find that all samples lack the *CypA* insertion in the *TRIM5* 3' UTR, the splice site SNP associated with TRIMCyp, and TRIMCyp expression. These findings indicate that TRIMCyp likely evolved in Old World primates after the divergence of *M. sylvanus* from the Asian macaques, approximately 5-6 million years before present (ybp). It then became fixed in *M. nemestrina* and *M. leonina* after their divergence from

M. nigra, approximately 2 million ybp. Identification of the evolutionary origin of TRIMCyp in Old World primates suggests that retroviral selection may have helped to shape the speciation of Asian macaques.

RESULTS

Baboons lack TRIMCyp and the *CypA* insertion

Old World primate TRIMCyp has so far been found in Asian macaques, and not in sooty mangabeys, which are African primates that belong to the papionin clade, a sister clade to the macaques. Because the frequency of the TRIMCyp allele is variable among Asian macaques, we reasoned that it may also be present in species related to sooty mangabeys. To test this possibility, we examined baboons, which also belong to the papionin clade. We tested five baboons, including four *P. cynocephalus anubis* and one *P. hamadryas*, for the *TRIM5* exon 7 splice site SNP, which is required for TRIMCyp expression. As controls, we used three *M. fascicularis* animals of known genotype. We initially used the restriction assay developed by Newman *et al.* (Newman *et al.*, 2008), which takes advantage of a second polymorphism upstream of the splice site. In macaques, the presence of an upstream *NsiI* restriction site is linked to the T allele at the splice site, and thus correlated with TRIMCyp expression. The absence of the *NsiI* site is linked to the G allele and correlated with the absence of TRIMCyp.

However, we found that this correlation does not apply in baboons. All five *Papio* samples had the *NsiI* restriction site at the expected location, but sequencing of this region of the genome demonstrated that these animals have the G allele at the splice site (Figure 6a) (GenBank HM468444-HM468446). Therefore, while the restriction assay is useful for genotyping macaques, it is not valid for baboons and should be verified when testing any new species.

We tested the same animals for the *CypA* insertion, using PCR primers designed to bind on either side of the putative *CypA* sequence in the 3' UTR of the *TRIM5* gene (Primers 3 and

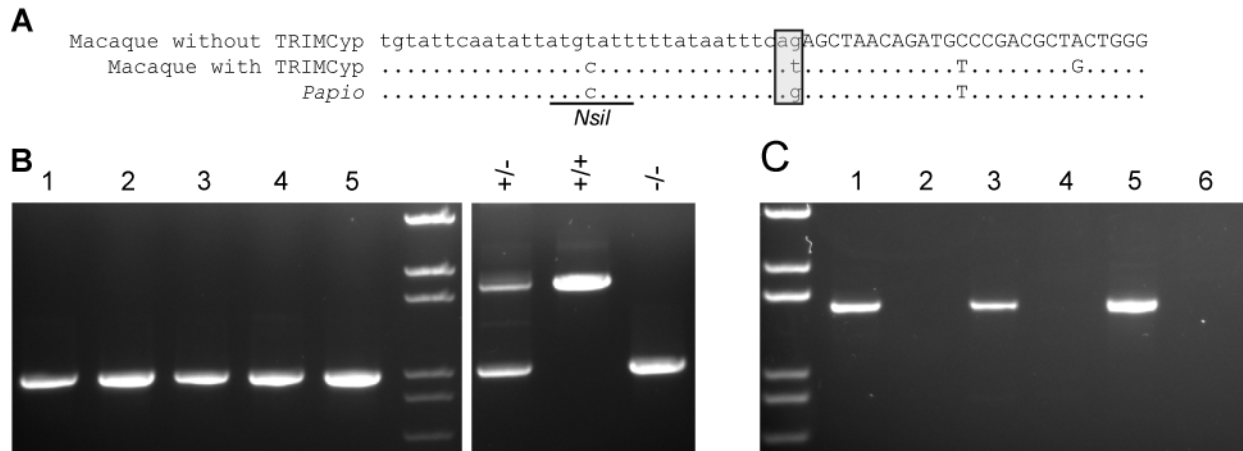

Figure 6. Baboons lack TRIMCyp. (A) Sequence of the intron 6/exon 7 junction, showing the splice site SNP and the *NsiI* polymorphism, in a macaque that expresses TRIMCyp (*M. nemestrina*, GenBank EU371641.1); a macaque lacking TRIMCyp (*M. mulatta* sequenced genome, GenBank NC_007871.1); and baboons (*Papio*, GenBank HM468444-HM468446). Capital letters, exon; lowercase letters, intron. Box, splice acceptor site. DNA from both *P. cynocephalus anubis* and *P. hamadryas* was sequenced, and all sequences were identical in the region shown here. (B) PCR across the *TRIM5* 3' UTR (Primers 3 and 6) in *P. cynocephalus anubis* (4 individuals, lanes 1-4) and *P. hamadryas* (lane 5). Three *M. fascicularis* of known genotypes were used as controls. Lane 6, *CypA* insertion heterozygote. Lane 7, homozygote with *CypA* insertion. Lane 8, homozygote lacking *CypA* insertion. (C) RT-PCR for TRIM5 α (lanes 1, 3, and 5; primers 1 and 4) and TRIMCyp (lanes 2, 4, and 6; primers 1 and 5) in cDNA from 3 *P. cynocephalus anubis*.

6). All five baboons had only the shorter PCR product, demonstrating the absence of the *CypA* insertion (Figure 6b). *P. cynocephalus anubis* individuals for which RNA was available also lacked TRIMCyp mRNA expression (Figure 6c). Thus, baboons, like sooty mangabeys, lack TRIMCyp expression and the *CypA* insertion. These data support the view that TRIMCyp is not present in the papionin clade, and that it evolved in the macaque lineage after its divergence from papionins.

TRIMCyp evolved after the divergence of Asian macaques and *M. sylvanus*

In order to further define the evolutionary origin of TRIMCyp among Old World primates, we examined *M. sylvanus*, which represents the earliest diverging macaque species. We sampled 36 *M. sylvanus* individuals from Gibraltar (Modolo et al., 2005). Unlike the baboons, all *M. sylvanus* lacked the *NsiI* restriction site (Figure 7a). Sequence analysis confirmed that they had the G allele at the splice site. Thus, the genetic linkage between the *NsiI* site and the SNP associated with TRIMCyp expression appears to be conserved among macaque species,

amplified using Primers 2 and 4 and consisted of introns 6 and 7 and exons 7 and 8 (see Figure 5). We also analyzed published sequences from *M. mulatta* and *M. nemestrina*. Of the sequences analyzed, four (three *M. fascicularis* and one *M. nemestrina*) had the T allele at the exon 7 splice acceptor, and were known or presumed to be linked to the *CypA* insertion; the remainder had the G allele at the splice site. *M. fascicularis* was the only species for which genomic DNA sequences in this region for both T-containing and G-containing alleles were available. Although some *M. mulatta* have the T allele, a complete sequence for the region analyzed here was not available from publicly accessible data.

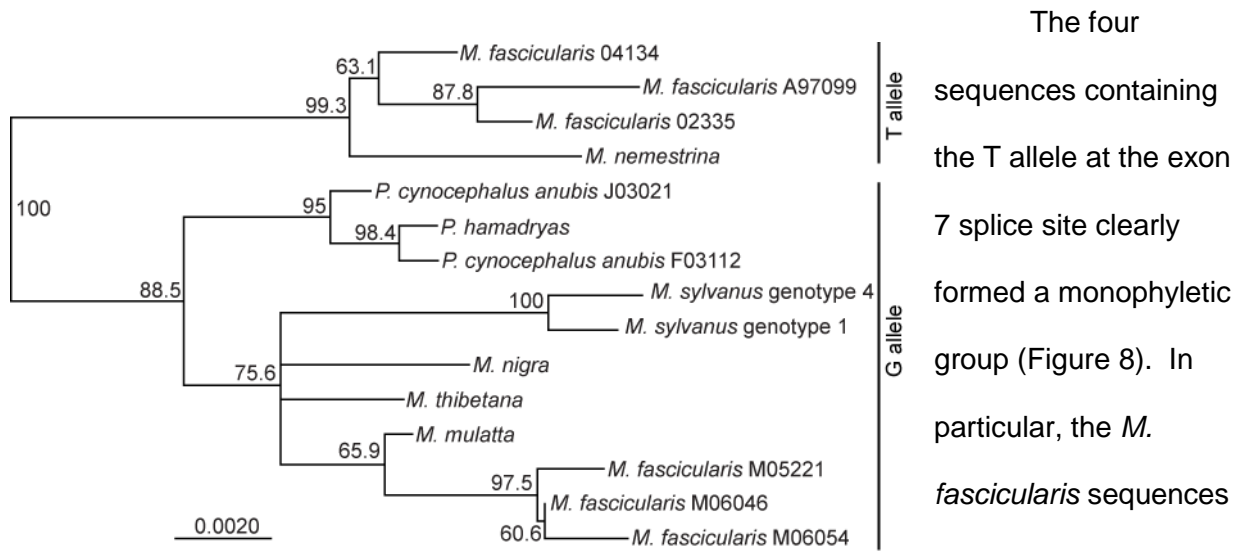

Figure 8. TRIMCyp-linked alleles form a monophyletic group. Phylogenetic tree of *TRIM5* genomic sequences from the exon 6-8 region. Tree was built using a neighbor-joining algorithm using the homologous human sequence as an outgroup (not shown). Bootstrap values from 1000 replicates are shown. Scale bar, substitutions per site.

the G allele grouped with *M. mulatta*. Similarly, *M. fascicularis* sequences containing the T allele grouped with *M. nemestrina*. This finding is consistent with the notion that the T allele associated with TRIMCyp expression evolved once, in the common ancestor of *M. fascicularis* and *M. nemestrina* (and thus of all Asian macaques), and has not been subsequently lost in any of the lineages studied.

TRIMCyp fixation in *M. nemestrina* and *M. leonina* occurred after divergence from *M. nigra*

To further define TRIMCyp evolution in Asian macaques, we tested one sample each from *M. thibetana* and *M. nigra*. Both of these samples lacked the *CypA* insertion and had the G allele at the exon 7 splice site (Figure 9). Thus, TRIMCyp is absent in at least

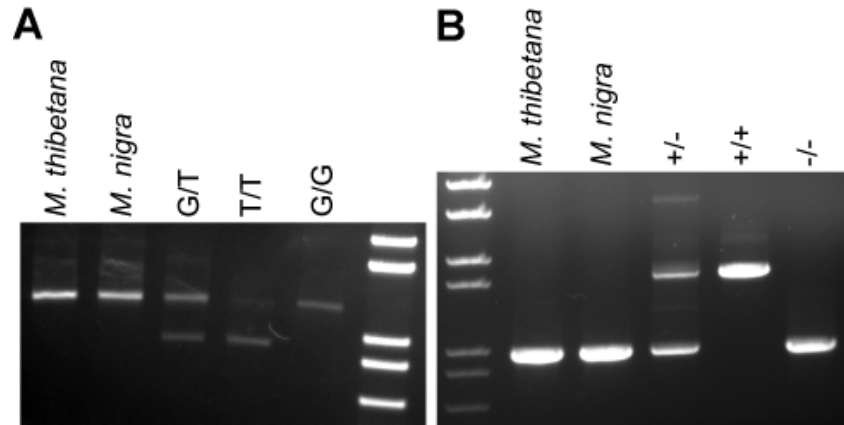

Figure 9. Single *M. thibetana* and *M. nigra* individuals lack TRIMCyp-related genetic changes. (A) *NsiI* restriction site assay on *M. thibetana* and *M. nigra*. (B) PCR across the *TRIM5* 3' UTR in *M. thibetana* and *M. nigra*. Three *M. fascicularis* of known genotype were used as controls (last 3 lanes of both parts A and B).

some individuals of these species. Phylogenetically, *M. thibetana* belongs to the *sinica* group, of which no members have previously been tested. *M. nigra* belongs to the *silenus* group, along with *M. nemestrina* and *M. leonina*. Because the *CypA* insertion and the T allele are fixed in *M. nemestrina* and *M. leonina* (Brennan et al., 2007; Brennan et al., 2008; Kuang et al., 2009; Newman et al., 2008), we conclude that TRIMCyp must have become fixed in the *M. nemestrina/M. leonina* lineage after it diverged from *M. nigra*.

***M. sylvanus* TRIM5 α is polymorphic and distinct from orthologues in closely related species**

In order to determine the level of diversity among the *M. sylvanus* samples tested and to ensure that the sample population was not homogeneous, we cloned and sequenced TRIM5 α cDNA from seven *M. sylvanus* (GenBank HM468429-HM468432). We found six SNPs, of which four result in amino acid substitutions and two are synonymous (Table 1). We also cloned and sequenced *TRIM5* exon 8 from genomic DNA in nine animals, including the same

seven from which TRIM5 α was cloned. At least four of nine animals were heterozygotes. Four of the SNPs (three nonsynonymous and one synonymous) are in the B30.2/SPRY domain, which is the capsid-binding domain and has been described as the most variable domain in other primate TRIM5 α sequences (Newman et al., 2006; Sawyer et al., 2005; Song et al., 2005a).

The SNP at amino acid 339 (nucleotide 1016) is within the “patch” of amino acids previously described as being under strong positive selection in primate lineages (Sawyer et al., 2005). Interestingly, this residue is also polymorphic in *M. mulatta* and *M. fascicularis*. In these species, one allele encodes amino acid residues TFP at residues 339-341. However, the other allele described in Asian macaques contains a glutamine (Q) residue at position 339; residues 340-341 are deleted. These two alleles are referred to as the TFP and Q alleles, respectively. The TFP allele of *M. mulatta* TRIM5 α restricts HIV-2 and SIVsm, while the Q allele does not, and an animal’s genotype at this position contributes to determining the outcome of *in vivo* infection (Kirmaier et al., 2010; Newman et al., 2006; Wilson et al., 2008a).

SNP	1		2		3		4		5		6	
	nt	aa	nt	aa	nt	aa	nt	aa	nt	aa	nt	aa
Residue	90	30	424	142	1016	339	1071	357	1072	358	1268	423
Allele 1	T	C	A	M	T	M	C	S	A	I	A	H
Allele 2	C	C	G	V	C	T	T	S	C	L	A	H
Allele 3	C	C	A	M	C	T	T	S	C	L	G	R
Allele 4	T	C	A	M	C	T	T	S	C	L	G	R
Domain	RING				Coiled Coil				B30.2/SPRY			

Table 1. Intraspecies polymorphisms in *M. sylvanus* TRIM5 α .

Nonsynonymous SNPs are marked in **bold**.

nt = nucleotide residue number

aa = amino acid residue number

Amino acid	29	44	69	112	139	142	177	217	247	296	298	310	330	333	339	358	385	423
<i>Papio</i>	P	R	Q	S	E	V	D	T	E	V	R	I	T	A	S	I	P	H
<i>M. sylvanus</i>	P	K	R	R	K	V/M	E	M	E	A	C	M	M	T	T/M	I/L	L	H/R
<i>M. mulatta</i>	H	K	Q	S	E	V	D	T	D	A	R	I	M	A/S	T/Δ	I	S	H
Domain	RING			B-Box	Coiled Coil								B30.2/SPRY					

Table 2. Interspecies comparison of predicted TRIM5 α amino acid sequence from *M. sylvanus*, *M. mulatta*, and *Papio cynocephalus anubis*.

Bold = not found in *P. cynocephalus* or *M. mulatta*

We also compared the predicted *M. sylvanus* TRIM5 α amino acid sequence with all six common alleles identified in *M. mulatta* (Newman et al., 2006), and with two *P. cynocephalus anubis* TRIM5 α sequences (Table 2). One of these baboon sequences was characterized for this study (GenBank HM468433), while the other was previously published (Kaiser et al., 2007). We found 13 *M. sylvanus*-specific residues, suggesting that extensive evolution has occurred in this species since its divergence from a common ancestor. Two residues (P29 and E247) were shared with baboons but not with *M. mulatta*, and four (K44, A296, M330, and T339 in some alleles) were shared with *M. mulatta* but not baboons. Six residues (M142, M310, M339, L358, L385, and R423) were not found in any other available TRIM5 α sequence, including those of apes and New World monkeys. Like the intraspecies polymorphisms, these interspecies differences were distributed throughout the length of the TRIM5 α gene, with a large number found in the B30.2/SPRY domain. We also found intraspecies polymorphism within *P. cynocephalus anubis* TRIM5 α , as there were one synonymous and three nonsynonymous SNPs between the newly characterized sequence and the published sequence (Kaiser et al., 2007). A synonymous variation in nucleotide 90 is polymorphic in both *M. sylvanus* and *P. cynocephalus anubis*. Thus, *M. sylvanus* TRIM5 α is polymorphic and unique among TRIM5 α proteins described to date.

M. sylvanus TRIM5 α polymorphism affects restriction specificity

To characterize the restriction activity of *M. sylvanus* TRIM5 α , we stably expressed HA-tagged versions of alleles 1 and 4 in CRFK cells (Figure 10A). We chose these two alleles because allele 1 was the most common in the animals we examined, while allele 4 was the most different from allele 1. Importantly, these two alleles differ at position 339, previously described to be important for restriction of HIV-2 and SIVsm (Kirmaier et al., 2010; Newman et al., 2006; Wilson et al., 2008a). Allele 4 encodes a threonine residue at this position, like those alleles of *M. mulatta* TRIM5 α that restrict HIV-2 and SIVsm. Allele 1, in contrast, encodes a methionine, which is unique to *M. sylvanus* among TRIM5 α sequences described to date.

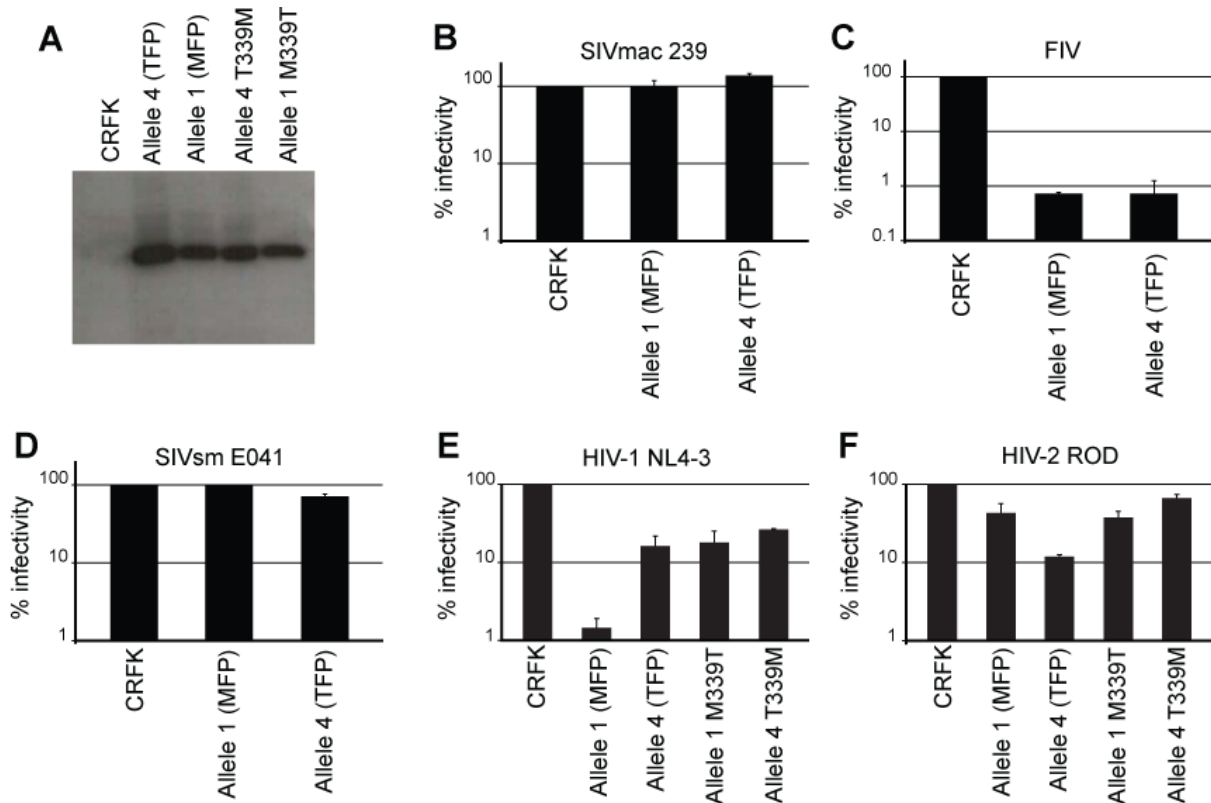

Figure 10. Restriction activity of *M. sylvanus* TRIM5 α . (A) Anti-HA immunoblot of CrFK cells expressing wild-type and mutant *M. sylvanus* TRIM5 α . (B-F) Restriction activity of *M. sylvanus* TRIM5 α against SIVmac (B), FIV (C), SIVsm E041 (D), HIV-1 NL4-3 (E), and HIV-2 ROD (F). Data shown are mean \pm standard deviation from three independent experiments.

We tested these two alleles for restriction activity against a panel of viruses (Figure 10B-F). Neither allele restricted SIVmac, while both restricted FIV. Both alleles restricted HIV-1 NL4-3, although allele 1 apparently restricted this virus better than allele 4. Neither allele restricted SIVsm well, although allele 4 had marginal restriction against this virus. Allele 4, like the similar *M. mulatta* allele restricted HIV-2 well, while allele 1 restricted this virus minimally if at all.

To determine whether the difference in restriction activity between allele 1 and allele 4 is due solely to the polymorphism at position 339, we performed site-directed mutagenesis at this site to create allele 1 M339T and allele 4 T339M constructs. When expressed in CrFK cells, allele 4 T339M lost its ability to restrict HIV-2. However, surprisingly, the M339T mutant did not allow allele 1 to gain restriction of HIV-2. This suggests that a threonine residue at position 339 is necessary but not sufficient for restriction of HIV-2. Similarly, allele 1 M339T lost its increased ability to restrict HIV-1, but allele 4 T339M did not gain this phenotype. Therefore, one or both of the other two differences between the two alleles must also contribute to the restriction phenotype against both HIV-1 and HIV-2.

DISCUSSION

We report here that TRIMCyp, and the genetic changes required for its expression, are absent in *M. sylvanus* and in two species of baboons. These data, in combination with data on sooty mangabeys (Newman et al., 2008), suggest that the common ancestor of the macaques also lacked TRIMCyp, and that TRIMCyp evolved after *M. sylvanus* diverged from the Asian macaques (Figure 11). Old World TRIMCyp expression results from two genetic changes that are invariably linked in species examined to date, namely a T allele at the exon 7 splice junction and a *CypA* insertion. The *CypA* insertion required for production of functional TRIMCyp in Old World primates is consistently found in the same genetic location, in the 3' UTR downstream of exon 8. Furthermore, we show that *CypA*-containing *TRIM5* DNA sequences are monophyletic. Taken together, these data indicate that functional TRIMCyp evolved only once in Old World

primates. Given the widespread distribution of TRIMCyp among the Asian macaques and its absence in African primates, we conclude that TRIMCyp expression evolved in the common ancestor of the Asian macaques.

Based on molecular evidence, the macaques are thought to have diverged from the papionin clade about 9-10 million ybp (Raum et al., 2005), although fossil and geological evidence indicates that this event could have occurred as recently as 6 million ybp (Kohler et al., 2000). Molecular evidence suggests that the Asian macaques diverged from *M. sylvanus* approximately 5.5-6 million ybp, and diverged from each other about 5-6 million ybp (Tosi et al., 2003; Ziegler et al., 2007). Based on these data and on our findings, we hypothesize that a retrovirus invaded the population of the Asian macaque progenitors approximately 5-6 million

novel antiretroviral factor and leading to the evolution of TRIMCyp in this clade. This event could have occurred either in Asia or in Europe or Africa, before these species arrived in Asia. The oldest macaque fossil found in Asia is dated at approximately 5.5 million years old, not long after the presumed divergence of Asian from African

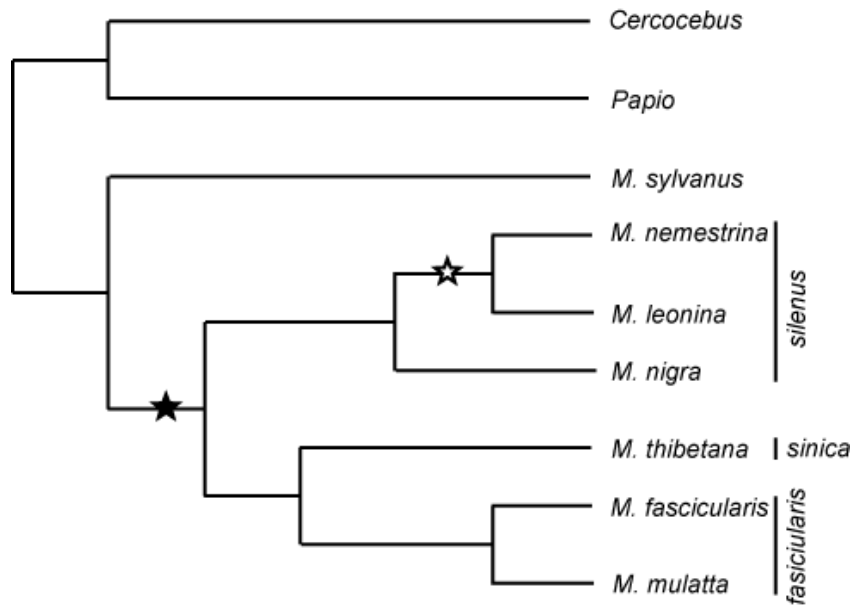

Figure 11. Model for TRIMCyp evolution in Old World primates. Schematic dendrogram showing the history of TRIMCyp evolution inferred here, in the context of established phylogenetic relationships among Old World primate species studied. Filled star, evolution of TRIMCyp. Open star, fixation of TRIMCyp. Asian macaque phylogenetic groups are indicated at right (Li et al., 2009). This graphical representation is not to scale and is not intended to reflect relative divergence. Relationships are adapted from Li et al., 2009; Page et al., 1999; and Tosi et al., 2003.

macaques, suggesting that the migration to Asia was relatively rapid (Delson, 1996). However, our data do not allow us to pinpoint a location for the evolution of TRIMCyp.

Although our data are most consistent with an origin of TRIMCyp in the common ancestor of Asian macaques, we have also considered several alternative hypotheses. First, it is possible that TRIMCyp was present in ancestral Old World primates but has been lost in all lineages other than Asian macaques. Results shown in Figure 8 clearly show that TRIMCyp sequences have not been lost at the DNA level, by deletion of the *CypA* sequence or by reversion of the exon 7 splice site. If this had occurred in some species, we would expect them to have the G allele but to group with the T-containing sequences, or to have the T allele in the absence of the *CypA* insertion. Neither of these features is present in any of the species tested. Instead, our data show unambiguously that sequences containing the T allele form a monophyletic group, distinct from those containing the G allele. Thus, it is unlikely that TRIMCyp was lost at the DNA level in any lineage.

In contrast, we cannot formally rule out the possibility that TRIMCyp was lost by lineage sorting. In our phylogenetic analysis, the T alleles appear to branch off before the separation of baboon and macaque G alleles (see Figure 8). This could be taken to suggest that the T allele evolved before this evolutionary branching, and thus that TRIMCyp, or at least TRIMCyp-linked sequence changes, may be older than suggested by our other data. However, this analysis is complicated by the possibility of different evolutionary rates in different sequences. In sequences that do not encode TRIMCyp (i.e. those with the G allele), approximately half of the region included in this analysis consists of coding sequence. In sequences containing the T allele, the entire region could be considered to be noncoding and thus potentially under relaxed selection. In these sequences, exon 8 (587 bp) is still used to code for TRIM5 η ; however, no biological function has been ascribed to this isoform (Brennan et al., 2007). Due to this uncertainty, no firm conclusions can be drawn from our phylogenetic analysis about the timing

of the evolution of the T allele. Thus, the most parsimonious explanation for our data remains that TRIMCyp-related sequences evolved once in the ancestral Asian macaque lineage.

Although it is unlikely that Old World TRIMCyp itself has been lost by lineage sorting, it should be noted that lineage sorting has almost certainly played a part in the evolution of this gene. Expression of functional Old World TRIMCyp requires two genetic changes that must originally have happened independently, namely a single nucleotide transversion and a retrotransposon-mediated insertion. Therefore, ancestral individuals must have had one in the absence of the other. The splice site T allele in the absence of the *CypA* insertion would probably be disadvantageous, since such an animal would be unable to produce either TRIM5 α or TRIMCyp, likely making it more susceptible to retroviruses (Brennan et al., 2007). It is unclear whether the presence of the *CypA* insertion in the absence of the T allele would allow any expression of TRIMCyp. However, under these circumstances, TRIMCyp would likely be only a minor splice variant. Thus, these two genetic changes are expected to confer a strong selective advantage only in combination. The hypothetical ancestral form, with only one of the two genetic changes, has likely been lost by lineage sorting, due either to selection or to genetic drift.

We also considered the possibility that TRIMCyp is present in *M. sylvanus* but was not detected in our study. *M. sylvanus* individuals have been repeatedly introduced into Gibraltar, and animals in this population have mitochondrial haplotypes representative of the most common alleles found in both Algerian and Moroccan populations (Modolo et al., 2005). All existing wild *M. sylvanus* populations live in these three countries; thus, the Gibraltar population is representative of the species as a whole (Modolo et al., 2005). Our *M. sylvanus* samples consisted of 36 animals from the Gibraltar colony. This colony currently contains approximately 230 animals belonging to six groups, with group sizes ranging from 14-64 individuals per group. We sampled individuals from all six groups. The animals in our sample also have diverse

TRIM5 sequences, so they do not represent closely related animals with similar or identical genotypes. Statistically, the absence of TRIMCyp in any of our 36 sample animals implies that the prevalence of TRIMCyp in our population of 230 is no higher than 8.3 percent or 19 animals ($p < 0.05$, according to the binomial probability distribution). Thus, although we cannot rule out the possibility that TRIMCyp is present in less than 10% of the Gibraltar population, or that it is a rare genotype in African *M. sylvanus* that is not present in the Gibraltar population, we believe that the available data are best explained by a model in which TRIMCyp evolved after the divergence of *M. sylvanus* from the Asian macaques.

A final alternative hypothesis is that TRIMCyp evolved in one group of Asian macaques after their divergence from other Asian macaques, and entered other groups by hybridization and introgression. A scenario in which TRIMCyp evolved specifically in the *silenus* group, which includes *M. nemestrina* and *M. leonina*, and later entered the *fascicularis* group, could explain the fact that it is fixed in *M. nemestrina* and *M. leonina* but not in *M. mulatta* or *M. fascicularis*. However, we believe that this hypothesis is not plausible. Although there is extensive literature on introgression between *M. fascicularis* and *M. mulatta*, there is currently no evidence of introgression between more distant macaque groups (Kanthaswamy et al., 2008; Tosi et al., 2003). Further, the geographic range of *M. nemestrina* and *M. leonina* overlaps with that of Chinese, but not Indian, *M. mulatta*. This contrasts with the presence of TRIMCyp in Indian but not Chinese *M. mulatta*. Thus, we believe that the most plausible scenario is that TRIMCyp evolved in the common ancestor of Asian macaques, and is not present in *M. sylvanus* or other Old World monkeys. We suggest that its variable frequency in different taxa results from the complex selective pressures exerted by multiple and different retroviral challenges.

Although TRIMCyp expression likely conferred a selective advantage on Asian macaque ancestors, it did not become fixed in the general Asian macaque population. TRIMCyp expression is polymorphic in both *M. fascicularis* and *M. mulatta*, and absent in individuals of *M.*

thibetana and *M. nigra* reported here. TRIM5 α alleles are thought to be subject to balancing selection in Old World monkeys, based on the existence of ancient shared polymorphisms (Newman et al., 2006), and it seems likely that TRIMCyp is subject to similar evolutionary pressures. Thus, if animals are subject to challenge both by retroviruses that are susceptible to TRIM5 α and by those susceptible to TRIMCyp, the maintenance of both restriction factors in the population would be beneficial. Our dataset does not provide molecular evidence to support the activity of balancing selection by Tajima's *D* test (Tajima, 1989) (data not shown); however, the dataset is small, and its power to detect such selection is low. Thus, it is possible that the long-term maintenance in some Asian macaque species of both TRIM5 α and TRIMCyp-expressing alleles may be due to balancing selection. Alternatively, there may be direct advantages to heterozygosity in this retroviral restriction factor, which could have led to the maintenance of both alleles.

M. sylvanus lacks many common viruses enzootic to other macaque species, including herpesviruses (cytomegalovirus and Cercopithecine herpesvirus) as well as retroviruses (simian immunodeficiency virus, simian retrovirus, and simian T cell leukemia virus) (Engel et al., 2008). The only retrovirus known to exist in this species is simian foamy virus (Engel et al., 2008). This lack of viral infections could be due either to unusually potent antiviral immunity in this species or to a simple lack of exposure, as *M. sylvanus* does not normally have contact with other nonhuman primate species. The many species-specific polymorphisms in *M. sylvanus* TRIM5 α , some of which are in regions known to be important for antiviral specificity, could be a result either of adaptive evolution or of genetic drift. The functional studies described here do not clearly resolve these possibilities, although the limited restriction activity against SIVsm, compared to that seen in *M. mulatta* TRIM5 α , is suggestive of genetic drift. However, it is possible that *M. sylvanus* TRIM5 α has activity against viruses that we did not test.

We confirmed the importance of residue 339 for HIV-2 and SIVsm restriction in the *M. sylvanus* system. These data may help to explain the difference in restriction capability between the two *M. mulatta* TRIM5 α alleles, in which the change in amino acid sequence from TFP to Q leads to the loss of restriction against HIV-2. We now show that the much less dramatic change from TFP to MFP also leads to the loss of restriction, suggesting that the threonine residue at this position is specifically important. However, while this residue was necessary for HIV-2 restriction, it was not sufficient. These data implicate either or both of two additional residues, I358L or H423R, in HIV-2 restriction. Neither of these residues has been previously shown to be important, although Sawyer *et al.* found that residue 422 is under positive selection (Sawyer *et al.*, 2005). L358 is unique to *M. sylvanus*, and other primates have an isoleucine at this position, with the exception of some New World monkeys, which have a phenylalanine. The residue at position 423 is more variable, but all Old World monkeys other than *M. sylvanus* encode a histidine residue. Both L358 and R423 are found in *M. sylvanus* allele 4 but not allele 1, which implies that full restriction activity may require the absence of one or both of the *M. sylvanus*-specific polymorphisms. Future studies will help to resolve these issues.

These data also suggest that there is a trade-off between restriction of HIV-1 and HIV-2 in *M. sylvanus* TRIM5 α . Allele 1 restricts HIV-1 better than it does HIV-2, while the opposite is true for allele 4. These data are reminiscent of the trade-off seen between HIV-1 and HIV-2 restriction in *M. fascicularis* TRIMCyp (Dietrich *et al.*, 2011a; Ylinen *et al.*, 2010), and together suggest that there may be a fundamental trade-off between these two restriction specificities. While it is obvious that neither *M. sylvanus* nor *M. fascicularis* evolved under pressure to restrict HIV-1 or HIV-2, these viruses may act as markers for restriction specificity of viruses that the species may have encountered either extinct or present but unknown. Given that *TRIM5* is under balancing selection in other related nonhuman primate populations, the maintenance of these two alleles in the population may be beneficial (Newman *et al.*, 2006).

TRIMCyp in New World primates evolved independently from its counterpart in Old World primates. Based on its presence in all members of the genus *Aotus* and its absence from others species, New World TRIMCyp must have evolved between 4.5 and 22 million ybp (Ribeiro et al., 2005). This date range encompasses the 5-6 million ybp proposed here for the evolution of Old World TRIMCyp. Available data do not allow us to distinguish whether the concurrent evolution of TRIMCyp in these two lineages was due to a worldwide retroviral epidemic or to multiple and separate events. However, findings reported here, together with existing evidence (Delson, 1996; Li et al., 2009; Ziegler et al., 2007), allow us to define with unprecedented precision the time and possible geographic origin for the evolution of TRIMCyp in Old World primates. These data also provide evidence linking the evolution of an antiretroviral restriction factor with a speciation event, namely the divergence of Asian macaques from the *M. sylvanus* lineage. Understanding the evolution of host restriction factors among macaque species will elucidate natural antiviral mechanisms and help us to better use these species as animal models for retroviral diseases such as HIV/AIDS.

CHAPTER 4. Variable Prevalence and Functional Diversity of the Antiretroviral Restriction Factor TRIMCyp in *Macaca fascicularis*

ABSTRACT

The retroviral restriction factor TRIMCyp, derived from the *TRIM5* gene, blocks replication at a post-entry step. TRIMCyp has so far been found in four species of Asian macaques, *Macaca fascicularis*, *M. mulatta*, *M. nemestrina*, and *M. leonina*. *M. fascicularis* is commonly used as a model for AIDS research, but TRIMCyp has not been analyzed in detail in this species. We analyzed the prevalence of TRIMCyp in samples from Indonesia, Indochina, the Philippines, and Mauritius. We found that TRIMCyp is present at a higher frequency in Indonesian than in Indochinese *M. fascicularis*, and is also present in samples from the Philippines. TRIMCyp is absent in Mauritian *M. fascicularis*. We then analyzed the restriction specificity of TRIMCyp derived from three animals of Indonesian origin. One allele, like the prototypic TRIMCyp alleles described in *M. mulatta* and *M. nemestrina*, restricts HIV-2 and FIV but not HIV-1. The others restrict HIV-1 and FIV but not HIV-2. Mutagenesis studies confirmed that polymorphism at amino acid residues 369 and 446 in TRIMCyp (or 66 and 143 in the CypA domain) confer restriction specificity. Additionally, we identified a polymorphism in the coiled coil domain that appears to affect TRIMCyp expression or stability. Taken together, these data show that *M. fascicularis* has the most diverse array of *TRIM5* restriction factors described in any primate species to date. These findings are relevant to our understanding of the evolution of retroviral restriction factors and the use of *M. fascicularis* models in AIDS research.

INTRODUCTION

Primates express several intrinsic restriction factors that can combat retroviral infection (Neil and Bieniasz, 2009). One of the best studied is TRIM5 α , which binds to the retroviral capsid and restricts replication at a post-entry step (Stremlau et al., 2004). TRIM5 α belongs to the *TRIM* (tripartite motif) gene family, a large family found throughout vertebrates with numerous members that have been implicated in immune responses (Ozato et al., 2008;

Sardiello et al., 2008). *TRIM* genes contain, in order, RING, B-Box, and coiled-coil domains (Reymond et al., 2001). TRIM5 α also has a C-terminal B30.2/SPRY domain, which is required for binding to retroviral capsids (Sawyer et al., 2005; Stremlau et al., 2006).

In some primates, the retrotransposition of a cyclophilin A (*CypA*) sequence into the *TRIM5* gene allows expression of the TRIMCyp isoform. Alternative splicing to this insertion results in the replacement of the capsid-binding B30.2/SPRY domain with a CypA domain, which is also capable of binding some retroviral capsids (Lin and Emerman, 2006). Thus, TRIMCyp, like TRIM5 α , has retroviral restriction activity, but its specificity is determined by the CypA domain rather than the B30.2/SPRY domain. Interestingly, TRIMCyp has evolved independently by separate retrotransposition events in two distantly related primate genera, *Aotus* (owl monkeys, New World monkeys), and *Macaca* (macaques, Old World monkeys) (Brennan et al., 2008; Liao et al., 2007; Nisole et al., 2004; Sayah et al., 2004; Virgen et al., 2008; Wilson et al., 2008b). In macaques, the *CypA* insertion is linked to a single nucleotide polymorphism (SNP) at the exon 7 splice acceptor site, which changes the canonical AG splice acceptor sequence to AT and allows skipping of exons 7 and 8 and splicing to the *CypA* sequence in the 3' untranslated region (UTR) of the gene (Brennan et al., 2007; Brennan et al., 2008).

These genetic changes are thought to be fixed in *Macaca nemestrina* and *M. leonina*; all individuals in these species examined so far express TRIMCyp but not TRIM5 α (Brennan et al., 2007; Brennan et al., 2008; Liao et al., 2007). In contrast, TRIMCyp is found in approximately 25% of Indian *M. mulatta*, and has not been found in at least 76 Chinese *M. mulatta* reported so far (Newman et al., 2008; Wilson et al., 2008b). Both TRIMCyp and TRIM5 α are expressed in *M. fascicularis* (Brennan et al., 2008), but the prevalence of the two forms in this species has not previously been examined.

M. fascicularis, known as cynomolgus, longtail, or crab-eating macaques, occupies a geographic range in Southeast Asia including parts of Indochina, Indonesia, and the Philippines (Street et al., 2007; Tosi et al., 2003). These animals can be sorted into genetically distinct subpopulations (Kanthaswamy et al., 2008; Smith et al., 2007). However, all *M. fascicularis* analyzed in the TRIMCyp literature to date have been of Indonesian origin (Brennan et al., 2008; Ylinen et al., 2010). Given the known geographic variability of TRIMCyp in *M. mulatta* (Wilson et al., 2008b), we hypothesized that similar geographic variations may exist in *M. fascicularis* TRIMCyp. Additionally, we sought to expand our knowledge of the allelic variability of *M. fascicularis* TRIMCyp.

Aotus TRIMCyp binds to and restricts the same viruses that bind to parental CypA, including HIV-1 and feline immunodeficiency virus (FIV) (Nisole et al., 2004; Sayah et al., 2004). However, the prototypical Old World TRIMCyp sequences, from *M. mulatta* and *M. nemestrina*, restrict HIV-2 but not HIV-1, due to two amino acid changes in the CypA domain (Brennan et al., 2008; Price et al., 2009; Virgen et al., 2008; Wilson et al., 2008b). The *M. fascicularis* TRIMCyp allele originally described by our laboratory had no detectable restriction activity (Brennan et al., 2008). However, whether this lack of activity was a true reflection of the allelic diversity of *M. fascicularis* TRIMCyp, or was the result of a cloning error, cannot be definitively ascertained. Recently, Ylinen *et al.* described a second allele of *M. fascicularis* TRIMCyp, and showed that its CypA domain can bind to and restrict HIV-1 (Ylinen et al., 2010). Therefore, we also sought to examine the functional diversity of TRIMCyp among *M. fascicularis*.

Here, we show that TRIMCyp-linked genotypes are present at significantly different frequencies in different *M. fascicularis* populations. We show that *M. fascicularis* has alleles of TRIMCyp that can restrict either HIV-1 or HIV-2, and that both alleles are found in all TRIMCyp-expressing *M. fascicularis* populations. These findings are likely to have critical implications for the use of *M. fascicularis* in AIDS-related research.

RESULTS

TRIMCyp prevalence varies among *M. fascicularis* populations

In order to determine the prevalence of TRIMCyp in different *M. fascicularis* populations, we performed the *NsiI* restriction assay described by Newman *et al.* (Newman *et al.*, 2008). This assay takes advantage of a second polymorphism closely linked to the splice site polymorphism that is required for TRIMCyp expression (Figure 12). Sequences with this *NsiI* restriction site have the T allele at the splice site, which is linked to the presence of the *CypA* insertion and the ability to

produce TRIMCyp. Sequences lacking the *NsiI* site have the G allele at the splice site, lack the *CypA* insertion, and cannot produce TRIMCyp. Initially, we tested nine animals of Indonesian

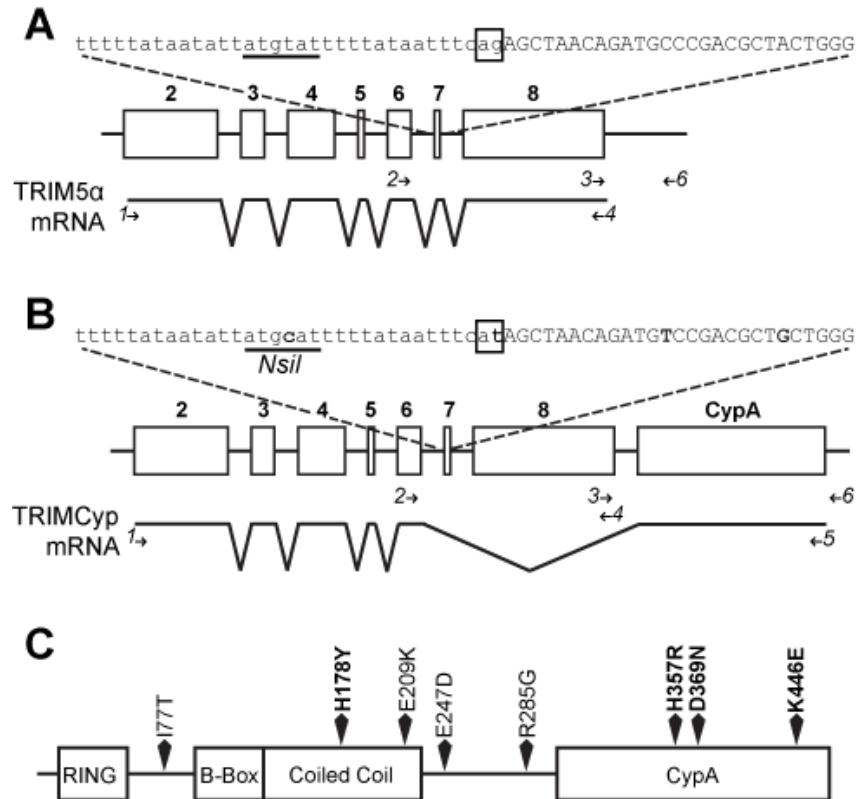

Figure 12. Genomic organization and mRNA splicing of *TRIM5* alleles. (A) *TRIM5α*-expressing allele. At top is the sequence of the intron 6-exon 7 junction, with intronic sequence in lowercase and exon 7 in capital letters. The canonical AG splice acceptor dinucleotide is boxed. The underlined sequence represents the location of the *NsiI* restriction site in the other allele. Below is a schematic of the *TRIM5* gene, with open boxes representing exons 2-8 numbered in bold. The mRNA splicing pattern indicated below. (B) *TRIMCyp*-expressing allele. Sequence changes from the sequence in (A) are in bold, and the *NsiI* site is labeled. Below, the *CypA* insertion in the *TRIMCyp*-expressing allele is located as indicated. Minor splice isoforms in both alleles are not depicted. Primers used for analyses described in subsequent figures and text are depicted as arrows and numbered in italics. Primers used for genomic analysis are shown above the mRNA diagram, and those for RT-PCR analysis shown below. Primer 4 was used for both analyses. (C) Primary structure of *TRIMCyp*, showing polymorphisms found in *M. fascicularis*. Residues known to affect protein function are marked in bold.

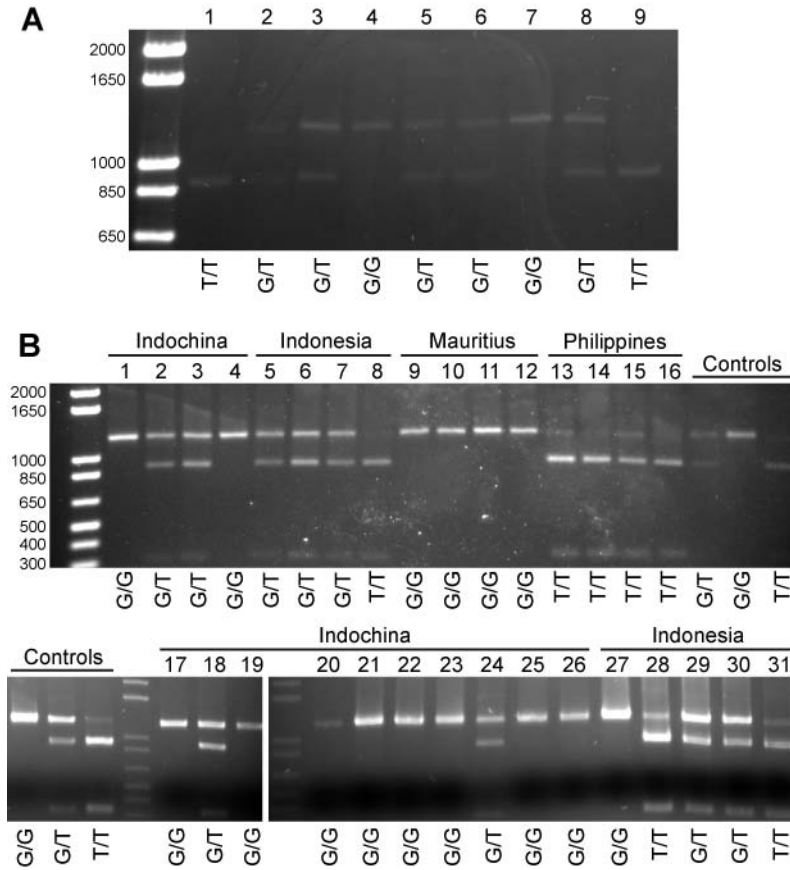

Figure 13. *NsiI* restriction analysis of *TRIM5* genotype in *M. fascicularis* populations. *NsiI* restriction analysis was used to determine splice site genotype. The uncut band, which is associated with the G allele and the absence of TRIMCyp, is expected to be approximately 1194 bp; the cut band associated with the T allele and the presence of TRIMCyp is expected to be approximately 891 bp. Inferred genotype is shown below the gel. (A) Animals of Indonesian origin housed at WaNPRC. (B) Samples from Indonesia, Indochina, Mauritius, and the Philippines. Samples tested in part (A) were used as controls (labeled) to test for the completion of digestion in independent assays. For inferring genotype, band density was quantified using Quantity One software (Bio-Rad) and compared to controls processed at the same time.

origin housed at WaNPRC (Figure 13a). At least three clones of this region from each animal were also sequenced to ensure the accuracy of the restriction assay (GenBank HQ834776-HQ834786). We then genotyped an additional nine animals of Indonesian origin, as well as 14 of Indochinese origin, 4 of Mauritian origin, and 4 from the Philippines (Figure 13b). All

four animals from Mauritius were G/G homozygotes, while all 4 animals from the Philippines were T/T homozygotes. In contrast, the samples from both Indonesia and Indochina were

genetically variable. The T allele was significantly more prevalent in Indonesian than Indochinese animals (Table 3) ($p = 0.0008$, Fisher's exact test).

Origin	# animals	# animals of genotype			allele frequency (%)	
		GG	GT	TT	G	T
Indonesia	18	3	10	5	44.4	55.6
Indochina	14	10	4	0	85.7	14.3
Mauritius	44	44	0	0	100	0
Philippines	4	0	0	4	0	100

Table 3. Frequency of TRIMCyp-linked alleles in *M. fascicularis* populations.

G or T refers to the single nucleotide polymorphism (SNP) at the exon 7 splice acceptor site linked to the expression of TRIMCyp (Fig. 1). GG or TT refers to homozygotes and GT refers to heterozygotes.

To further verify these findings, we tested a subset of the samples using a PCR assay designed to detect the presence or absence of the *CypA* insertion (Wilson et al., 2008b). These data confirmed the results of the restriction assay (Figure 14), lending support to the idea that the *CypA* insertion and the splice site T allele are invariably linked in macaques.

M. fascicularis animals of Mauritian origin have been developed recently as an AIDS model (O'Connor et al., 2010; Wiseman et al., 2007). Because this population is genetically

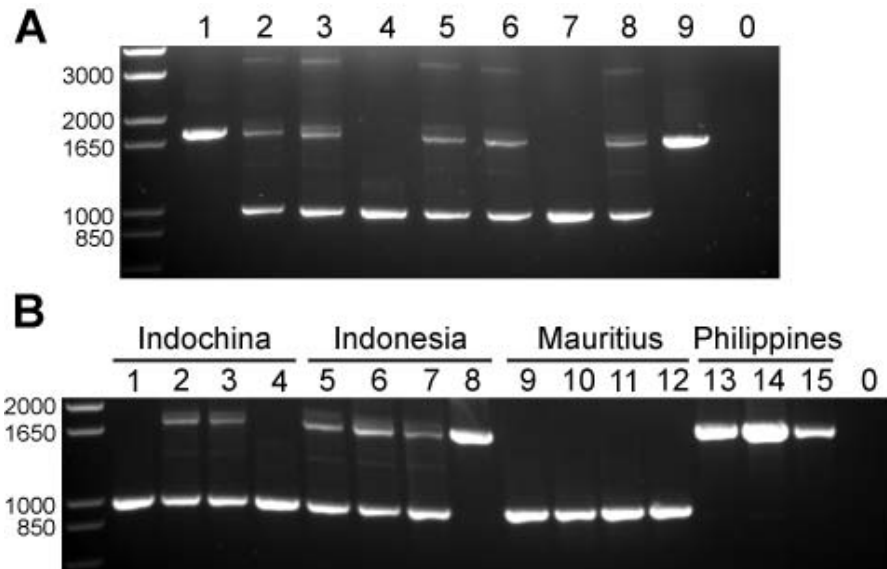

Figure 14. PCR analysis of *CypA* insertion in *M. fascicularis* populations.

PCR was performed using primers 3 and 6, spanning the 3' UTR and the putative *CypA* insertion. Band containing insertion is expected to be 1750 bp; band without insertion is expected to be 994 bp. (A) WaNPRC animals. (B) Geographically diverse samples shown in Figure 13B, top panel. In both parts, negative control PCR reactions with no template are marked 0.

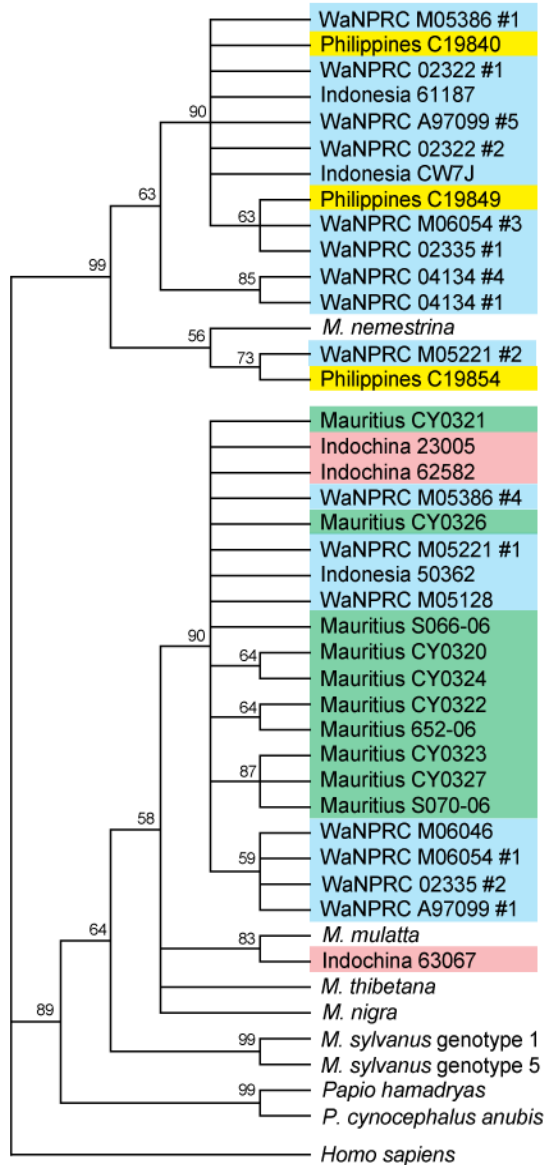

Figure 15. Phylogenetic tree of intron 6 – exon 8 region. The intron 6 – exon 8 region of the *TRIM5* gene was cloned and sequenced. *M. fascicularis* are classified based on geographic origin; other species are as indicated. All WaNPRC *M. fascicularis* are of Indonesian origin. Multiple clones were sequenced from each WaNPRC animal; thus, heterozygotes are present in two locations on the tree. Only one clone was sequenced from each of the other individuals. Sequences from *Papio*, *M. thibetana*, *M. nigra*, *M. sylvanus*, and six of the WaNPRC *M. fascicularis* were described previously (Dietrich et al., 2010). Tree was built using a maximum-parsimony algorithm (Tamura et al., 2011) using the human sequence as an outgroup. Similar results were also found using maximum likelihood and neighbor-joining algorithms (not shown). Bootstrap values from 1000 replicates are shown.

relatively homogeneous, we hypothesized that these animals completely lack TRIMCyp, based on its absence in the four samples that we initially tested. To test this hypothesis, we analyzed an additional 40 Mauritian *M. fascicularis* samples from animals currently in use for AIDS model studies. All were negative for TRIMCyp by both the *NsiI* restriction assay and PCR.

TRIMCyp-linked sequences form a monophyletic group

We sequenced clones of the region used in the *NsiI* restriction assay, comprising introns 6 and 7 and exons 7 and 8 (approximately 1194 bp) (GenBank HQ834757-HQ834786).

We found that these sequences clustered depending on their genotype at the exon 7 splice site (Figure 15). As previously reported (Dietrich et al., 2010a), sequences containing the T allele, which are presumably linked to the *CypA* insertion, formed a

monophyletic group, separate from those with the G allele, which are expected to lack the *CypA* insertion. *M. fascicularis* sequences grouped together, although, interestingly, one Indochinese animal (63067) clustered with the only available *M. mulatta* sequence. As expected, sequences from Mauritian animals clustered within a single clade, closely related to some sequences from Indonesian and Indochinese animals.

Diverse TRIMCyp genotypes in *M. fascicularis*

We cloned and sequenced full-length TRIMCyp cDNA from six of the seven TRIMCyp-positive *M. fascicularis* from WaNPRC analyzed previously (see Figure 13A). We found nine SNPS resulting in amino acid changes in various parts of the TRIMCyp gene (GenBank HQ834751-HQ834756) (Table 4; Figure 12C). We also sequenced the *TRIM5* gene in genomic DNA, to determine whether the SNPs in our cDNA clones resulted from cloning error. We found six likely cloning errors. Two of these were in the linker 2 region: M246T in M05386 and K272R

Animal	Residue at amino acid								
	77	178	209	247	285	310	357	369	446
<i>M. nemestrina</i>	I	H	E	E	G	S	H	N	E
04116	T	H	K	E	R	F	R	D	K
MafaTC2	I	H	E	D	R	F	H	D	K
A97099	I	H	K	E	R	F	H	D	K
02335	I	H	E	E	R	F	H	D	K
M06054	I	H	E	E	R	F	H	D	K
M05221	I	Y	E	D	G	F	H	D	K
M05386	I	Y	E	D	R	F	H	N	E
04134	I	H	E	E	G	F	H	N	E
Domain	Linker 1	Coiled Coil		Linker 2		B30.2/SPRY			

Table 4. Polymorphisms in *M. fascicularis* TRIMCyp.

L1, Linker 1 region between RING and B-Box domains

Bold letters indicate differences from consensus.

M. nemestrina and 04116 sequences are from Brennan et al., 2008. MafaTC2 is from Ylinen et al., 2010

in M06054. The other four were in the *CypA* domain: F310S in 02335, F310I and F370L in 04134, and N440D in M05386. These likely artifacts are not included in Table 4. None of these artifacts *per se* appeared to affect restriction activity or specificity (see below).

Amino acids 369 and 446 were previously described to be important for restriction specificity (Price et al., 2009; Ylinen et al., 2010). Two of the WaNPRC animals had asparagine residues at position 369 and glutamic acid at 446 (N369/E446; henceforth referred to as NE), while four had aspartic acid and lysine, respectively (D369/K446; DK).

To examine these variable TRIMCyp genotypes in geographically diverse populations, we sequenced the *CypA* insertion region from additional animals—four Indonesian, two Indochinese, and three Filipino (see Figure 14) (Genbank HQ840753-HQ840761). The only polymorphisms found in these sequences were at positions 369 and 446; the *CypA* sequences were otherwise identical to the consensus found in the Indonesian WaNPRC samples. All three animals from the Philippines had the DK genotype (D369/K446). In contrast, one Indochinese animal had DK and the other had NE (N369/E446). Two Indonesian animals had NE, one had DK, and, interestingly, one had DE (D369/E446). The DE genotype has not previously been described in natural isolates, but an isolated *CypA* domain of this genotype has been created by mutagenesis and found to restrict both HIV-1 and HIV-2 (Ylinen et al., 2010). Unfortunately, because RNA from that animal is not available, we were not able to clone full-length TRIMCyp cDNA in order to determine the restriction function of this genotype from a natural isolate. However, we did confirm the restriction specificity of DE-containing TRIMCyp proteins by mutagenesis (see Figure 17).

***M. fascicularis* TRIMCyp alleles have two distinct restriction activities**

To characterize the restriction activity of the *M. fascicularis* TRIMCyp variants described above, we expressed HA-tagged versions of three of the WaNPRC *M. fascicularis* TRIMCyp alleles in TRIM5-negative feline CrFK cells (Figure 16A). One of these, from animal 04134, had

the NE genotype. The other two, from animals 02335 and A97099, had the DK genotype. We then infected these cells with GFP-expressing, VSV-G pseudotyped HIV-1 NL4-3, HIV-2 ROD, SIVmac, and FIV (Figure 16). None of the alleles restricted SIVmac (data not shown), and all restricted FIV. The 04134 allele (NE genotype) restricted HIV-2 but not HIV-1, like TRIMCyp isolates with the NE allele previously described in *M. mulatta* and *M. nemestrina* TRIMCyp (Brennan et al., 2008; Price et al., 2009; Virgen et al., 2008; Wilson et al., 2008b). The other two alleles, A97099 and 02335 (DK genotype), restricted HIV-1 but not HIV-2, as recently described for an independent *M. fascicularis* TRIMCyp allele, which also had the DK genotype (Ylinen et al., 2010).

Amino acids 369 and 446 are determinants for TRIMCyp restriction specificity

To verify and extend previous findings on the restriction determinants in Old World monkey TRIMCyp, we created D369N and K446E mutants in the A97099 background (referred to as A97099 NK and DE, respectively), and similarly N369D and E446K mutants in the 04134 background (referred to as 04134 DE and NK, respectively). TRIMCyp in either

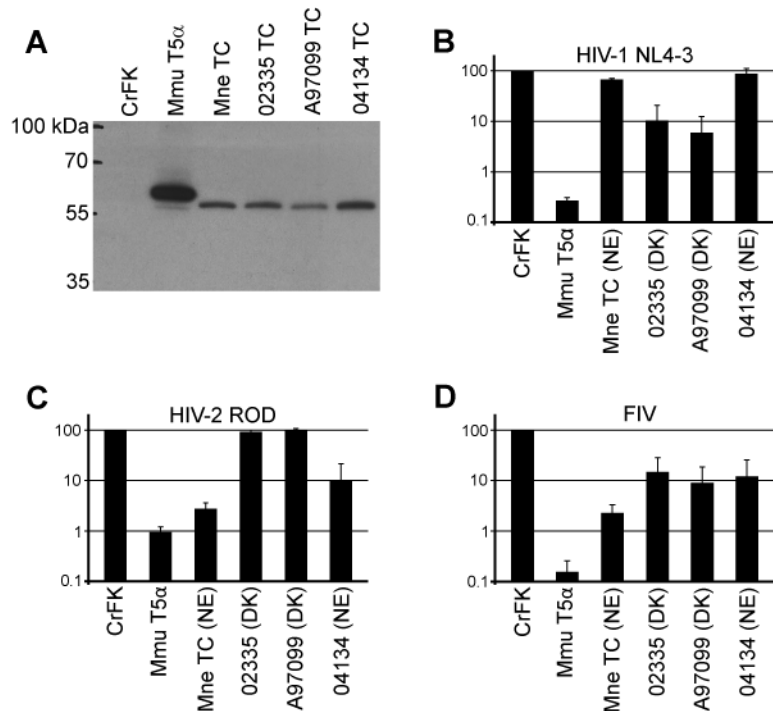

Figure 16. Expression and antiviral restriction activity of *M. fascicularis* TRIMCyp. (A) Anti-HA immunoblot of CrFK and CrFK-derived TRIM5 α - and TRIMCyp-expressing cell lines. (B) Restriction activity of CrFK and TRIMCyp-expressing cell lines against HIV-1 NL4-3. (C) Restriction activity against HIV-2 ROD. (D) Restriction activity against FIV. Controls are TRIM5 α from *M. mulatta* (Mmu T5 α), and TRIMCyp from *M. nemestrina* (Mne TC). Genotypes at amino acid positions 369 and 446 are shown as NE (N369/E446) or DK (D369/K446). Data shown are mean \pm standard deviation from three independent experiments using one representative dilution of virus (11 ng RT/well for HIV-1 and HIV-2; 33 ng RT/well for FIV).

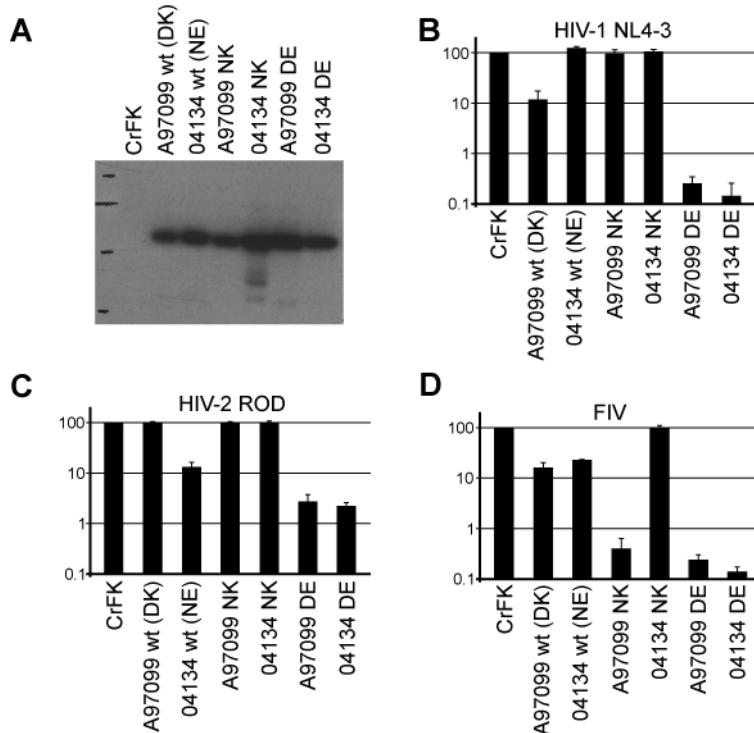

Figure 17. Amino acids 369 and 446 determine TRIMCyp restriction activity. (A) Anti-HA immunoblot of control and mutagenized TRIMCyp-expressing CrFK cell lines. (B) Restriction activity against HIV-1 NL4-3. (C) Restriction activity against HIV-2 ROD. (D) Restriction activity against FIV. Genotypes at amino acid positions 369 and 446 are shown, as in Figure 16. Data shown are mean \pm standard deviation from three independent experiments using one representative dilution of virus (11 ng RT/well for HIV-1 and HIV-2; 33 ng RT/well for FIV).

DNA, and are not shown in Table 4). Interestingly, NK-containing TRIMCyp restricted FIV in the A97099 background but not in the 04134 background (**Figure 17**). Therefore, one or more of the four differences between these two TRIMCyp proteins must have additional critical effects on the restriction of FIV.

background containing DE residues restricted both HIV-1 and HIV-2, as previously described (Ylinen et al., 2010), as well as FIV (Figure 17). TRIMCyp with the NK residues restricted neither HIV-1 nor HIV-2.

Aside from the differences at positions 369 and 446, there are four additional amino acid differences between A97099 and 04134 TRIMCyp, at positions 209, 285, 310, and 370 (Table 4; the differences at positions 310 and 370 are probable cloning artifacts that were not found in genomic

Residue 178 affects TRIMCyp protein expression or stability

We also attempted to produce cell lines expressing M05221 (DK) and M05386 (NE) TRIMCyp. After two independent transductions, we were not able to produce a cell line expressing these alleles at levels comparable to those attained for the other three TRIMCyp alleles analyzed (Figure 18 and data not shown). Cell lines expressing low levels of these TRIMCyp proteins had no or negligible restriction activity (data not shown). These two alleles share an H178Y polymorphism in the coiled coil domain of TRIMCyp (Table 4). We therefore

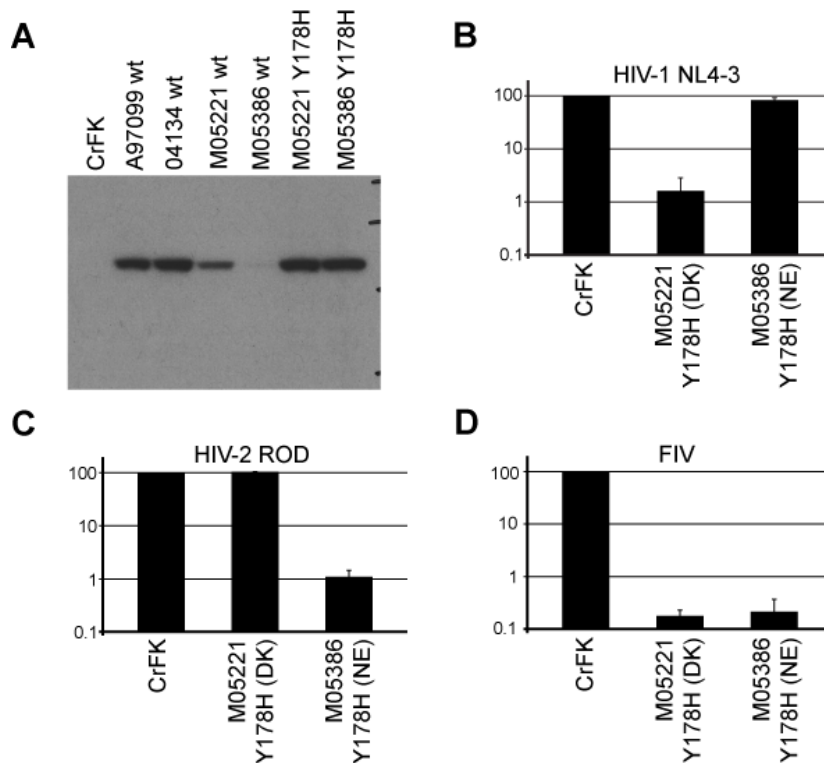

Figure 18. Amino acid 178 affects TRIMCyp protein expression or stability. (A) Anti-HA immunoblot of control and mutagenized TRIMCyp-expressing CrFK cell lines. Cell lines expressing wild-type and H178Y TRIMCyp from M05221 and M05386 were transduced and grown in parallel. (B) Restriction activity against HIV-1 NL4-3. (C) Restriction activity against HIV-2 ROD. (D) Restriction activity against FIV. Genotypes at amino acid positions 369 and 446 are shown, as in Figure 16. Data shown are mean \pm standard deviation from three independent experiments using one representative dilution of virus (11 ng RT/well for HIV-1 and HIV-2; 33 ng RT/well for FIV). Cell lines expressing wild type M05221 and M05386 had no or negligible restriction activity (not shown).

mutagenized this site to the consensus histidine residue. Cells transduced with the resulting mutant H178 alleles expressed TRIMCyp stably and at high levels, whereas parallel transductions done with wild type M05221 and M05386 alleles did not (Figure 18A). The restriction specificity of both Y178H mutants was as predicted by their genotype at amino acid positions 369 and 446 (Figure 18).

DISCUSSION

Here, we present a detailed description of TRIMCyp in *M. fascicularis*. We show that *M. fascicularis* is more diverse than any other species described to date, with respect to the presence or absence of TRIMCyp and to its restriction specificity. We found differences among animals both within and between geographic populations. TRIMCyp was present in three of four populations tested. Within Indonesian and Indochinese populations of *M. fascicularis*, three active antiretroviral TRIM5 proteins with different specificities coexist, namely TRIM5 α , TRIMCyp DK, and TRIMCyp NE. We also show that one individual had a DE genotype, which has not previously been found in natural isolates. It will be of interest to determine the prevalence of this genotype in natural populations. Although we were not able to create a cDNA clone of that individual, our mutagenesis results as well as the results of others suggest that it likely has an expanded restriction specificity. Identification of the DE allele in naturally occurring *M. fascicularis* populations, even at a low frequency, suggests that this genotype should be taken into consideration when designing HIV studies involving *M. fascicularis*.

Our phylogenetic analysis is consistent with our previous findings, in which TRIMCyp-linked sequences (with T at the exon 7 splice acceptor site) clustered together separate from all other sequences (with G at the splice acceptor site) (Dietrich et al., 2010a). These findings suggest that TRIMCyp arose early in the evolution of the Asian macaques. The clear differentiation between T-containing and G-containing alleles is likely due to a combination of founder effects and changed selection pressures. At one time in evolutionary history there would presumably have been an intermediate state, containing the *CypA* insertion in the absence of the splice acceptor polymorphism, or vice versa; however, such sequences have not been found in existing populations.

The current work also serves to expand our understanding of the evolution of TRIMCyp in *M. fascicularis*. Indochinese *M. fascicularis* overlaps in geographic range with Chinese *M.*

mulatta, and genetic evidence indicates that the two species have experienced and likely are currently experiencing hybridization and introgression (Kanthaswamy et al., 2008; Street et al., 2007; Tosi et al., 2003). Interestingly, TRIMCyp is apparently absent in Chinese *M. mulatta* (Newman et al., 2008; Wilson et al., 2008b). Introgression with TRIMCyp-negative Chinese *M. mulatta* may have decreased the prevalence of TRIMCyp in Indochinese *M. fascicularis*, potentially explaining the lower prevalence of TRIMCyp in Indochinese than in Indonesian *M. fascicularis*. Such introgression likely also explains the fact that the *TRIM5* sequence from an Indochinese *M. fascicularis* clustered phylogenetically with an *M. mulatta* sequence rather than with other *M. fascicularis*. Because gene flow between the species appears to be unidirectional from *M. mulatta* to *M. fascicularis*, it is unlikely that Indochinese *M. fascicularis* have contributed TRIMCyp to *M. mulatta*, although this possibility cannot be entirely ruled out (Bonhomme et al., 2009; Stevison and Kohn, 2009).

M. fascicularis was introduced to Mauritius in historical times, likely from Indonesian (Sumatran) stock (Kanthaswamy et al., 2008; Smith et al., 2007; Tosi and Coke, 2007). The initial founding population was small, and genetic signs of founder effects are apparent in the population (Kanthaswamy et al., 2008; Tosi and Coke, 2007; Wiseman et al., 2007). The fact that TRIMCyp is apparently absent in Mauritian individuals, but common in the parental Indonesian population, underscores the genetic bottleneck involved in the founding of the Mauritius colony. Previous genetic studies have found that sequences from Mauritian individuals tend to cluster apart from those from other *M. fascicularis* (Smith et al., 2007). Although our phylogenetic analysis is consistent with this finding, we were not able to resolve the relationships among TRIMCyp-negative *M. fascicularis*, due to the limited sequence data available. Because of the low genetic diversity in the Mauritian *M. fascicularis* population, these animals are of particular interest as an AIDS model (Cafaro et al., 2010; Krebs et al., 2005; O'Connor et al., 2010; Smith et al., 2007). The finding that these animals uniformly lack

TRIMCyp, which could be a confounding factor in infection studies, indicates the potential for additional advantages of working with this model.

Our group previously reported an *M. fascicularis* TRIMCyp clone (04116, also referred to as MafaTC1 (Ylinen et al., 2010)) that had no detectable antiviral activity (Brennan et al., 2008). This lack of activity was likely due to an H357R mutation, which prevents binding to the viral capsid (Ylinen et al., 2010). However, we were unable to replicate this sequence using archival samples, and no animals we have subsequently tested have this genotype. Since the initial cloning of the 04116 allele was performed using a low-fidelity polymerase, the H357R mutation may have been an artifact introduced during cloning. Thus, its physiological relevance is uncertain. We have subsequently optimized the procedure to minimize such artifacts, and whenever possible confirm the cDNA sequence with genomic DNA sequencing.

We tested three TRIMCyp alleles and three mutated versions for restriction activity. Our mutagenesis analysis confirms previous reports that residues 369 and 446 are important for restriction specificity (Price et al., 2009; Ylinen et al., 2010). Furthermore, because at least one animal sequenced had the DE genotype, our finding supports the potential biological relevance of DE-containing TRIMCyp proteins (Ylinen et al., 2010). In contrast, the NK genotype, which has not previously been analyzed and was not found in any of the animals tested, restricted neither HIV-1 nor HIV-2. Interestingly, only one of the two NK-containing proteins tested restricted FIV. This result may provide interesting clues about the determinants required for this restriction activity, although it may result from one of the two introduced mutations in the CypA domain of 04134 TRIMCyp.

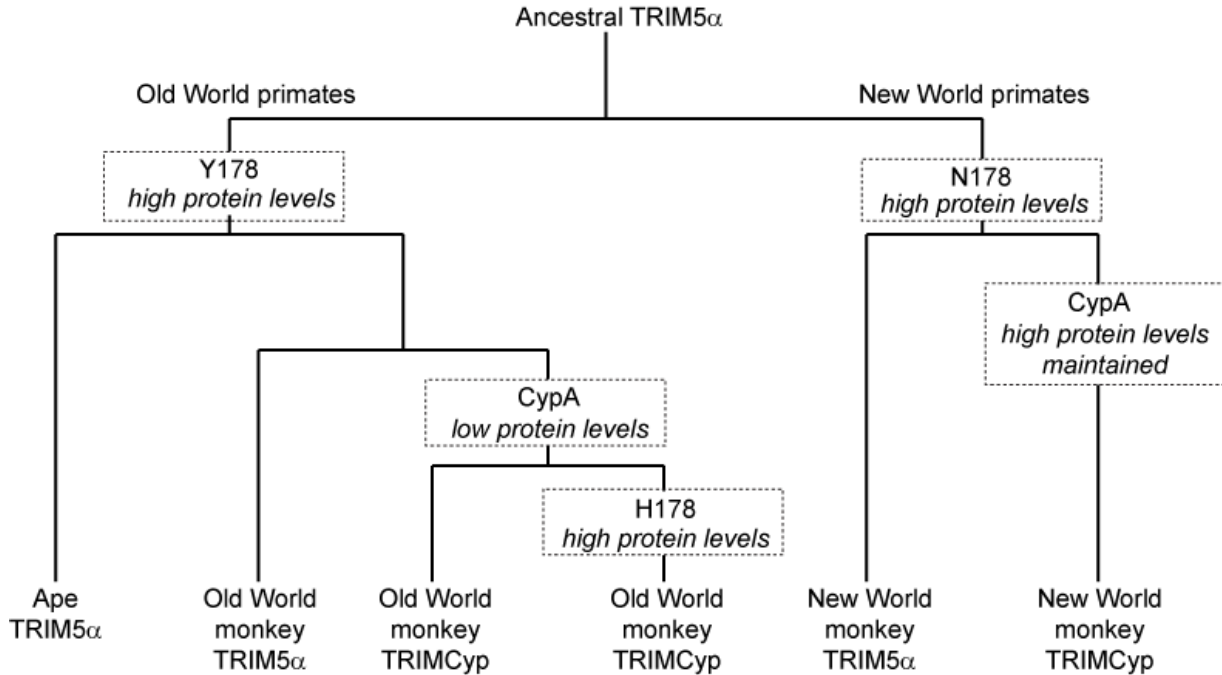

Figure 19. Schematic for the evolution of TRIMCyp residue 178. The TRIM5α sequence in the common ancestor of Old World monkeys and apes would have encoded a tyrosine residue at position 178, whereas that in New World monkeys would have encoded an asparagine residue. It is not clear what residue would have been present in the common ancestor of both lineages. TRIMCyp evolved independently in the two lineages. The presence of Y178 in the context of TRIMCyp, but not TRIM5α, appears to lead to a reduction in protein levels. Thus, I propose that Old World monkeys evolved the Y178H polymorphism to improve TRIMCyp protein levels. In New World monkeys, the evolution of TRIMCyp in the context of N178 did not apparently cause a change in protein levels.

Our data also suggest that a polymorphism in the coiled coil region, H178Y, affects the ability to stably express TRIMCyp proteins. It is possible that this polymorphism either decreases protein stability or increases toxicity; we have not yet examined the mechanisms behind this effect. Further, it is not yet clear whether this effect will be seen *in vivo*, or whether it is an artifact of expression in CrFK cells. However, assuming that the differential expression of the two alleles is found *in vivo*, it may point to an interesting evolutionary story. The amino acid at this position is a histidine in all other Old World TRIMCyp proteins described to date and in *M. nemestrina* TRIM5 η , which is also produced by alternative splicing from the same allele as TRIMCyp. In contrast, all TRIM5α isolates described to date in Old World monkeys and apes have a tyrosine residue at this position, with the exception of one isolate from *M. fascicularis* (Kono et al., 2008). Thus, it seems likely that the initial form of TRIMCyp that evolved from

TRIM5 α would have encoded Y178 as well. If for some reason high level protein expression of TRIMCyp is not possible with Y178, the Y178H variant might represent an adaptation to improve TRIMCyp protein levels. Interestingly, New World monkeys encode an asparagine residue at this position in both their TRIM5 α protein and their TRIMCyp, which arose independently of that in Old World primates. Although residue 178 has not previously been shown to be important for any aspect of TRIM5 biology, residue 177 is under positive selection, suggesting that this region of the coiled coil domain may be important for restriction activity (Sawyer et al., 2005). It is therefore tempting to speculate that the histidine allele at amino acid 178 could have been selected in some Old World primates due to improved TRIMCyp expression levels (Figure 19).

TRIM5 α alleles have evolved under both positive and balancing selection (Newman et al., 2006; Sawyer et al., 2005). The balancing selection is likely due to pressure from pathogens restricted by different alleles (Newman et al., 2006). Although TRIMCyp evolved recently in Old World primates, as it is found only in Asian macaques (Dietrich et al., 2010a), it is also likely to be under balancing selection. The presence of multiple restriction phenotypes in *M. fascicularis* TRIMCyp, in addition to TRIM5 α , may reflect a history of such balancing forces in this species and its ancestors. Current TRIM5 α and TRIMCyp expression patterns have also likely been influenced by evolutionary pressures such as genetic drift and founder effects, particularly in the Mauritius and Philippines populations (Kanthaswamy et al., 2008; Smith et al., 2007; Tosi and Coke, 2007), in addition to possible pressures from past retroviral infections.

Recently, it has become clear that differences in *TRIM5* genotype have dramatic effects on the outcome of SIV infection in *M. mulatta* (Kirmaier et al., 2010; Lim et al., 2010b; Lim et al., 2010c). It is likely that TRIM5 and TRIMCyp diversity in *M. fascicularis* has also played a role in the outcomes of infection during previous studies. It will be of interest to test the restriction of *M. fascicularis* TRIMCyp alleles against relevant SIV strains, and examine historical samples

from infected *M. fascicularis* to determine whether TRIMCyp genotype could have affected pathogenesis. More in-depth knowledge of restriction factors in model species will inform the choice of appropriate models for AIDS research and the proper interpretation of results.

CHAPTER 5. The Effect of Coexpression of *M. fascicularis* TRIM5 α and TRIMCyp

ABSTRACT

The primate *TRIM5* gene encodes multiple protein isoforms with different C-terminal domains. The C-terminal domains of the TRIM5 α and TRIMCyp isoforms bind to retroviral capsids and restrict viral replication at an early post-entry step. TRIM5 proteins can dimerize through their coiled coil domains, and it has been suggested that nonrestrictive isoforms may have dominant negative activity against restrictive isoforms. However, these experiments were carried out in cell culture systems in which TRIM5 protein expression levels were poorly controlled or characterized. I show here that TRIM5 α and TRIMCyp do not interfere with each other's restriction activity when expressed in cells at similar levels. This is consistent with *in vivo* data suggesting that these proteins may be codominant. Species such as *Macaca mulatta* and *M. fascicularis* express multiple TRIM5 proteins that may affect their susceptibility to retroviral infection. A better understanding of the potential interaction and functional interplay among TRIM5 proteins will inform the use of these species as models for AIDS research.

INTRODUCTION

TRIM5 α and TRIMCyp are restriction factors that block the replication of susceptible retroviruses in primates at an early post-entry step. TRIM5 α and TRIMCyp are both encoded by the *TRIM5* gene and share identical RING, B-Box, and coiled coil domains at their N-termini, all of which are required for antiviral function. TRIM5 α encodes a C-terminal B30.2/SPRY domain, while TRIMCyp encodes a cyclophilin A (CypA) domain at its C-terminus. Both the B30.2/SPRY domain and the CypA domain can bind to retroviral capsids. The antiviral specificity of TRIM5 α and TRIMCyp is determined by the capsid binding specificity of their respective C-terminal domains. In addition to TRIM5 α and TRIMCyp, multiple TRIM5 isoforms that are not known to have direct antiviral activity can also be expressed through genetic polymorphism and alternative

splicing. Any given primate cell likely expresses multiple isoforms, even if the individual is homozygous at the *TRIM5* locus (Battivelli et al., 2011a; Reymond et al., 2001).

TRIM5 proteins dimerize through the coiled coil domain, and dimerization is thought to contribute to capsid binding avidity (Javanbakht et al., 2006; Kar et al., 2011; Langelier et al., 2008; Mische et al., 2005). Because all TRIM5 isoforms contain the coiled coil domain, different TRIM5 proteins may be able to heterodimerize, and interaction between different TRIM5 proteins could impact their restriction activity against retroviruses.

Many macaque populations and species express multiple *TRIM5* alleles. *M. fascicularis* and *M. mulatta* encode both TRIM5 α and TRIMCyp (Brennan et al., 2008; Virgen et al., 2008; Wilson et al., 2008b; Dietrich et al., 2011a). Both species have multiple alleles of TRIM5 α (de Groot et al., 2011; Newman et al., 2006; Wilson et al., 2008a). *M. fascicularis* has multiple alleles of TRIMCyp, and it is possible that *M. mulatta* does as well, although the TRIMCyp diversity of this species has not yet been thoroughly explored (Berry et al., 2012; Dietrich et al., 2011a; Saito et al., 2012). One of the polymorphisms in *M. fascicularis* TRIMCyp is at position 178, in the coiled coil domain. Most Old World monkey TRIMCyp proteins encode a histidine residue at this position. Old world monkey TRIM5 α and some *M. fascicularis* TRIMCyp isolates encode a tyrosine residue at this position. In TRIMCyp but not TRIM5 α , the Y178 residue leads to decreased protein abundance in CrFK cells (Dietrich et al., 2011a). Because this polymorphism is in the coiled coil domain, it might also affect dimerization, but this has not yet been examined.

Ideally, the potential effects of TRIM5 protein coexpression on restriction activity should be examined using primate cells endogenously coexpressing the proteins of interest. However, currently such experiments are technically challenging because of the lack of satisfactory anti-TRIM5 antibodies. Some studies have found that coexpression of TRIM5 α with a nonrestrictive TRIM5 isoform leads to loss of TRIM5 α restriction activity. However, these studies have typically

been performed by overexpressing the nonrestrictive isoform in a primate cell line that expresses the restrictive isoform at much lower native levels (Battivelli et al., 2011a; McEwan et al., 2009; Nakajima et al., 2009; Stremlau et al., 2004; Wilson et al., 2008b).

Previous data on an unrelated restriction factor provide a precedent for suggesting that this unbalanced expression system may lead to artifacts that are not representative of *in vivo* restriction. The murine Fv1 protein restricts murine leukemia virus (MLV) at an early post-entry step. N-tropic MLV strains are restricted by the Fv1^b allele, while B-tropic strains are restricted by Fv1ⁿ. Heterozygous animals are resistant to both viruses. However, overexpression of Fv1ⁿ in cells naturally expressing Fv1^b leads to loss of Fv1^b activity, and vice versa (Bock et al., 2000). These data demonstrate the dangers of extrapolating from an artificial system and suggest that relative expression levels of restriction factor proteins, possibly including TRIM5 proteins, may affect their function.

A few studies have used dual overexpression techniques to study the effects of TRIM5 proteins lacking the B30.2/SPRY domain on wild-type TRIM5 α activity (Maegawa et al., 2008; Torimiro et al., 2009). Torimiro *et al.* found that a rare allele of human TRIM5 α that encodes a truncated protein had a dominant negative effect on the restriction activity of wild-type human TRIM5 α in a dual overexpression system (Torimiro et al., 2009). Similarly, Maegawa *et al.* found that an artificially created mutant lacking the B30.2/SPRY domain had strong dominant negative activity against TRIM5 α (Maegawa et al., 2008). However, no studies have yet examined the coexpression of two active antiviral TRIM5 proteins.

In vivo data support the idea that restrictive TRIM5 proteins are codominant rather than dominant negative. Kirmaier *et al.* showed that viral loads of SIVsm in infected *M. mulatta* were related to TRIM5 genotype. Animals with two restrictive alleles had significantly lower viral loads than did individuals with two nonrestrictive alleles. Critically, this was the case for TRIM5 α /TRIMCyp heterozygotes as well as animals that were homozygous for the restrictive

TRIM5 α allele. Similarly, animals with one restrictive and one nonrestrictive allele had intermediate viral loads (Kirmaier et al., 2010). Similar results were found in a study using SIVmac, although this study examined only different TRIM5 α alleles and not TRIMCyp (Lim et al., 2010c). These results suggest that nonrestrictive TRIM5 proteins do not have a dominant effect, and that different *TRIM5* alleles may be codominant.

Taken together, previous data indicate that overexpression of a nonrestrictive TRIM5 protein in cells endogenously expressing an antiretroviral TRIM5 results in a dominant negative effect. Dual overexpression of one functional and one truncated TRIM5 protein may also result in a loss of function. However, it is still unclear whether coexpression at similar levels of two functional TRIM5 proteins with different antiretroviral specificities would also lead to a dominant negative effect. The results of coexpression may be affected not only by the relative abundance of the different TRIM5 proteins, but also by the amount of viral capsid present, since TRIM5-mediated restriction is saturable. To further explore these issues, I coexpressed *M. fascicularis* TRIM5 α and TRIMCyp in CrFK cells. Here, I show that the two proteins act independently to restrict HIV-1 and HIV-2. Thus, in this system, there is no evidence of a dominant negative effect.

RESULTS

Increasing expression of TRIMCyp does not disrupt TRIM5 α restriction activity

Using a retroviral transduction system, I created a CrFK cell line stably expressing HA-tagged *M. fascicularis* TRIM5 α (isolate M06054) which restricts HIV-1 but has limited restriction activity against HIV-2 ROD. I then further transduced these cells with HA-tagged *M. fascicularis* TRIMCyp (isolate 04134; GenBank HQ834753.1) to create two independent cell lines, named 134Co1 and 134Co2, that coexpress TRIM5 α and TRIMCyp. 04134 TRIMCyp contains residues N369 and E446, and restricts HIV-2 but not HIV-1 (Dietrich et al., 2011a). Thus, restriction of

HIV-1 in the coexpressing cell lines is a measure of the antiviral activity of TRIM5 α , while restriction of HIV-2 is primarily a measure of TRIMCyp activity.

Because TRIMCyp is a smaller protein than TRIM5 α , the two proteins can be distinguished on a Western blot when both are HA-tagged (Figure 20A). Both 134Co1 and 134Co2 express levels of TRIM5 α similar to that in the cell line expressing TRIM5 α alone. However, 134Co1 expresses lower levels of TRIMCyp than 134Co2 does. Therefore, these two lines, in combination with the cell lines singly expressing TRIM5 α or TRIMCyp, allow us to determine whether increasing amounts of TRIMCyp lead to a decrease in TRIM5 α restriction activity.

I found that, as expected, restriction of HIV-2 ROD was correlated with TRIMCyp expression levels. Line 134Co1, which expresses a limited amount of TRIMCyp, did not have detectable restriction activity against HIV-2 ROD, while line 134Co2 restricted HIV-2 ROD approximately 10-fold. This was still lower than the restriction activity of the cell line expressing TRIMCyp alone, which expressed a higher level of TRIMCyp than either of the coexpressing cell lines.

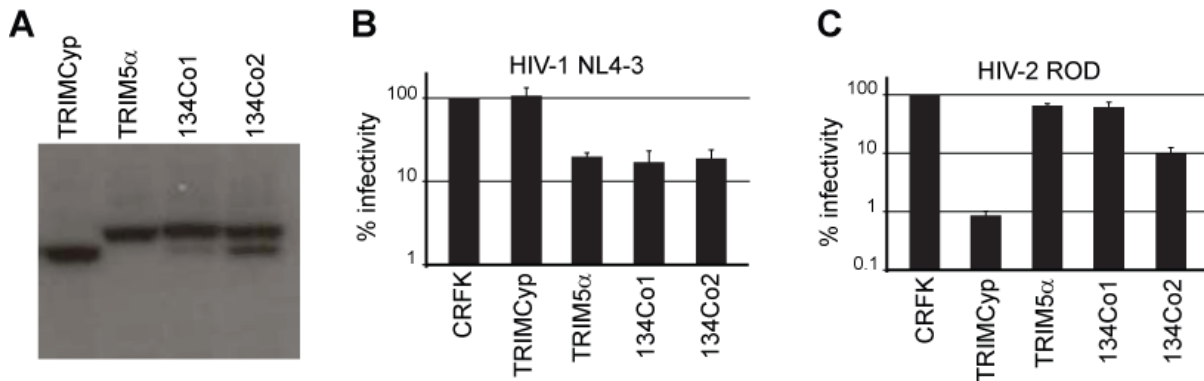

Figure 20. Coexpression of TRIMCyp does not diminish TRIM5 α restriction activity. (A) Anti-HA immunoblot of CrFK cells expressing *M. fascicularis* TRIM5 α , *M. fascicularis* 04134 TRIMCyp, or both proteins. (B) Restriction activity of TRIM5 α , TRIMCyp, or coexpressing cell lines against HIV-1 NL4-3. (C) Restriction activity of TRIM5 α , TRIMCyp, or coexpressing cell lines against HIV-2 ROD. Data shown are mean \pm standard deviation from three independent experiments.

In contrast, all three cell lines that expressed TRIM5 α restricted HIV-1 to a similar degree regardless of TRIMCyp expression. Thus, increasing amounts of TRIMCyp up to the amount expressed in the Co2 cell line do not lead to a decrease in TRIM5 α activity. This indicates that TRIMCyp does not have a dominant negative effect on TRIM5 α restriction activity under these experimental conditions.

TRIM5 α coexpression does not disrupt TRIMCyp restriction activity

The experiments described above were performed using a TRIMCyp encoding H178. In order to better control the relative expression of TRIMCyp, and to determine whether the allele at residue 178 in TRIMCyp affects the outcome of coexpression experiments, I used wild-type (Y178) and Y178H mutant variants of *M. fascicularis* TRIMCyp, isolate M05386 (GenBank HQ834755.1). The Y178H mutant is expressed at higher levels than the wild-type, and both isolates restrict HIV-2 to a degree consistent with their relative expression (Dietrich et al., 2011a). These experiments allowed me to examine the role of TRIMCyp protein abundance on TRIMCyp restriction activity against HIV-2 both individually and in the context of coexpression with TRIM5 α .

I transduced wild-type or Y178H M05386 TRIMCyp into either wild-type CrFK cells, or CrFK cells expressing *M. fascicularis* M06054 TRIM5 α . I created these cell lines twice independently. In both sets of cell lines, as described previously, the Y178H mutant was expressed at higher levels than the wild-type Y178 TRIMCyp, either in the presence or absence of TRIM5 α (Figure 21). Preliminary experiments showed variable restriction activity of *M. fascicularis* TRIM5 α against HIV-2 ROD, possible due to the saturable nature of TRIM5 restriction (Towers et al., 2000). To control for saturation, I performed further experiments using different amounts of viral inoculum. These dilutions represented a range of infectivity in CrFK cells not expressing any TRIM5 protein, from approximately 85% of cells infected at the highest

concentration of virus to approximately 3% infected at the lowest concentration (data not shown).

I found that *M. fascicularis* TRIM5 α restricts HIV-2 ROD in a readily saturable manner in the absence of TRIMCyp. In contrast, the restriction activity of TRIMCyp was not saturated even at the highest concentration of virus tested. Thus, *M. fascicularis* TRIM5 α restricts HIV-2 ROD, but this restriction activity is relatively weak compared to its activity against other viruses such as HIV-1 (see Figure 20) and to the activity of HIV-2-restricting TRIMCyp alleles.

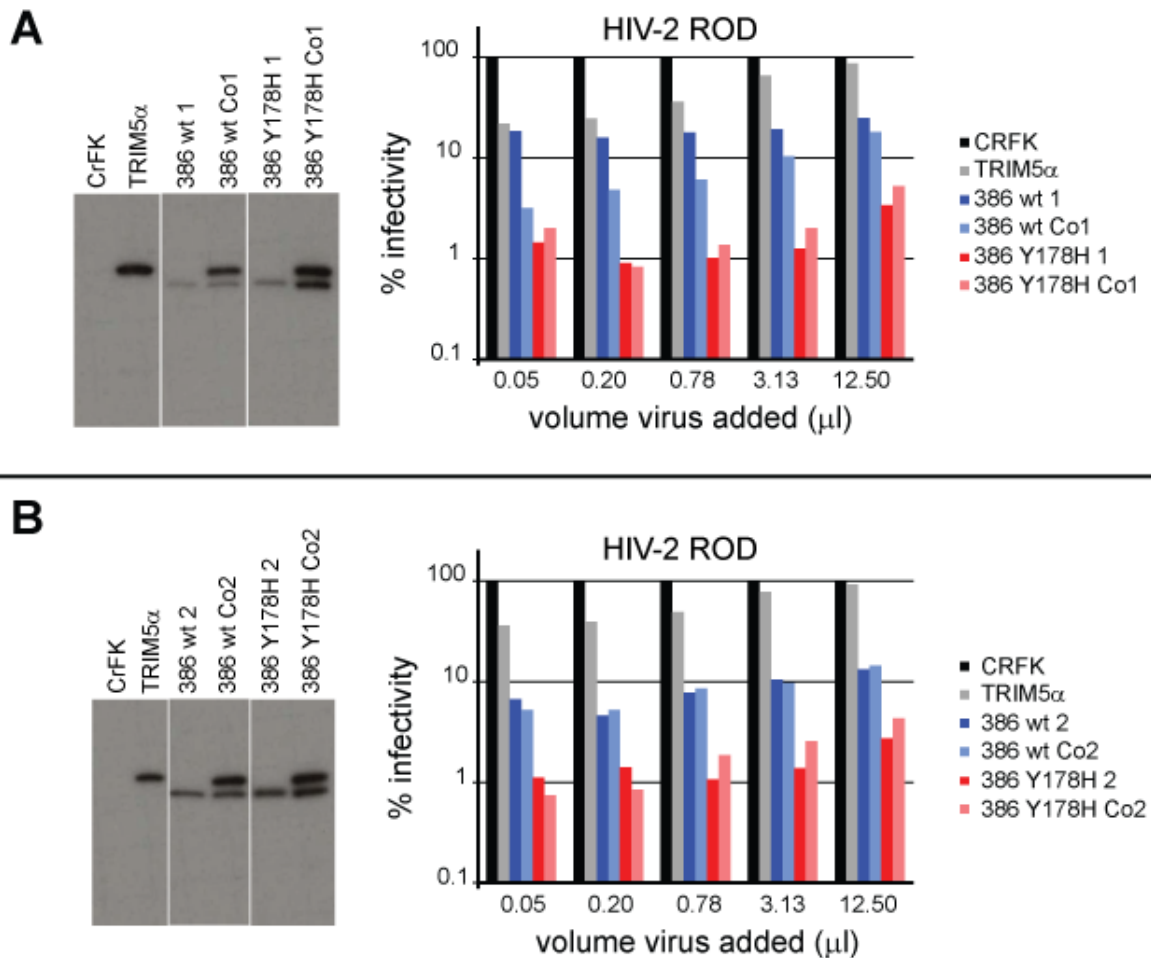

In one of two cell lines expressing TRIM5 α and wild-type M05386 TRIMCyp (386 wt Co1), the same saturable restriction activity of TRIM5 α was seen above and beyond the restriction activity of TRIMCyp alone (Figure 21A). However, this activity was not seen in the other cell line coexpressing TRIM5 α and Y178 TRIMCyp (386 wt Co2; Figure 21B), or in either of the cell lines containing the Y178H TRIMCyp mutant. This observation is consistent with the different TRIMCyp expression levels in these cell lines. Thus, the restriction activity of TRIM5 α was apparent only in the absence of high-level expression of TRIMCyp.

Although the precise interaction between TRIM5 α and TRIMCyp restriction in these experiments is unclear and likely to be complex, there were no conditions in these experiments in which TRIM5 α expression led to a loss of TRIMCyp restriction. To the contrary, TRIM5 α expression increased TRIMCyp restriction activity in the context of low TRIMCyp expression and low virus inocula. Thus, we can conclude that there is no dominant negative effect of TRIM5 α on TRIMCyp restriction in conditions where the two proteins were expressed at similar levels.

DISCUSSION

In this Chapter, I examined the functional consequences of the coexpression of TRIM5 α and TRIMCyp. Specifically, I aimed to address the question of whether coexpression interferes with the restriction activities of individual TRIM5 α or TRIMCyp proteins. I show that neither TRIM5 α nor TRIMCyp interferes with the restriction activity of the other when the two proteins are expressed at similar levels. Specifically, I show that increasing levels of TRIMCyp do not diminish the restriction activity of *M. fascicularis* TRIM5 α against HIV-1 NL4-3. Similarly, coexpression of TRIM5 α does not reduce the restriction activity of TRIMCyp against HIV-2 ROD. Overall, my data are consistent with the *in vivo* data on SIVsm infection of *M. mulatta* (Kirmaier et al., 2010) and suggest that the dominant negative effect seen previously was likely an artifact of overexpressing one protein relative to the other (Wilson et al., 2008b).

The *M. fascicularis* TRIM5 α isolate used here has some restriction activity against HIV-2 ROD. This limited restriction activity is readily saturated by increasing amounts of virus and is lost in the presence of high levels of TRIMCyp. Thus, although the less restrictive TRIM5 α protein does not disable the more restrictive TRIMCyp, the reverse may be true. It is unclear whether this effect would have any practical consequences *in vivo*, since the stronger restriction activity would predominate in any case. However, it will be of interest to explore further. Another group has described HIV-2 isolates that are not restricted at all by their *M. fascicularis* TRIM5 α isolate, unlike HIV-2 ROD (Kono et al., 2008; Song et al., 2007). It would be interesting to test whether these other HIV-2 isolates are restricted by TRIMCyp and by our TRIM5 α isolate. If they are restricted only by TRIMCyp, these isolates would likely provide a more definitive system for examining the effects of coexpression than we were able to use here.

The *M. fascicularis* TRIM5 α isolate described by Song *et al.* has potent restriction activity against HIV-2 ROD (Song et al., 2007). Their isolate (GenBank AB210052.1) differs from ours at several amino acid positions, including three positions in the B30.2/SPRY domain (Kono et al., 2008). One or more of these polymorphisms may explain the difference in restriction of HIV-2 ROD between my experiments and theirs. Interestingly, one of these polymorphisms results in a histidine residue at position 178, which has not been described in any other TRIM5 α isolate and may result from recombination between TRIM5 α and TRIMCyp-expressing *TRIM5* alleles (see Chapter 4). The robust restriction activity that they describe indicates that this residue does not disable TRIM5 α , as the corresponding Y178 residue decreases expression of TRIMCyp in our system.

Torimiro *et al.* showed that wild type human TRIM5 α lost its limited ability to restrict HIV-1 when it was coexpressed with a truncated mutant; however, its restriction of N-MLV was only partially abrogated (Torimiro et al., 2009). These data suggest that nonrestrictive TRIM5 α alleles may have a dominant negative effect on relatively weak restriction activity, but that the effect on

stronger restriction may be less pronounced. Although the two studies are not directly comparable, the data described by Torimiro *et al.* are consistent with my data showing that weak TRIM5 α -mediated restriction activity is lost in the presence of stronger restriction activity mediated by TRIMCyp. However, the data from Torimiro *et al.* are difficult to interpret because they used different epitope tags on the two TRIM5 proteins, meaning that the expression levels cannot be directly compared. My experimental design, which uses a single epitope tag on both proteins, circumvents this issue.

Maegawa *et al.* found that an artificial mutant lacking the B30.2/SPRY domain had strong dominant negative activity against four different primate TRIM5 α proteins, while TRIM5 γ had limited or no dominant negative activity. The authors attribute the difference to reduced expression of TRIM5 γ in their system, but it is difficult to judge whether TRIM5 γ expression is sufficiently decreased to explain the data, particularly since they do not show the expression levels of the TRIM5 α proteins (Maegawa *et al.*, 2008). It is also possible that some aspect of the TRIM5 γ protein that is not present in their artificially truncated protein may act to limit dominant negative activity. It should also be noted that in human cells, TRIM5 γ accounts for less than 10% of total *TRIM5* mRNA, whereas TRIM5 α accounts for approximately 50% (Battivelli *et al.*, 2011a). Thus, if TRIM5 γ needs to be expressed at high levels in order to have a dominant negative effect, it seems unlikely to have this effect *in vivo*, at least in humans.

It is still unclear whether TRIM5 α and TRIMCyp can heterodimerize, and this will be an important issue to address in the future. The dominant negative effect seen by Torimiro *et al.* and Maegawa *et al.* suggests that the proteins they examined may heterodimerize, although they do not show this directly. In contrast, my results suggest that TRIM5 α and TRIMCyp proteins act independently, which is easiest to explain if they do not interact. It is possible that the truncated proteins lacking C-terminal domains can heterodimerize with TRIM5 α , but TRIMCyp cannot. Perhaps heterodimerization is sterically hindered by the presence of two

different C-terminal domains. Alternatively, perhaps differences in protein trafficking prevent different isoforms from interacting in a way that is not recapitulated by the truncated mutants examined in previous studies.

It is also possible that the proteins in my study do heterodimerize, and heterodimers maintain some antiviral activity even when one monomer cannot independently bind to viral capsids. Langelier *et al.* showed that recombinant *M. mulatta* TRIM5 α -derived monomers can bind to HIV-1 capsids, but that homodimerization improved avidity under stringent conditions (Langelier *et al.*, 2008). However, higher-order self association is also thought to increase TRIM5 protein avidity for viral capsids (Ganser-Pornillos *et al.*, 2011). Perhaps the avidity gained by higher-order self association is sufficient to compensate for decreased avidity of individual TRIM5 α /TRIMCyp heterodimers to a viral isolate only recognized by one of the two variants. In this case, it is unclear why the same effect was not seen by Torimiro *et al.* and Maegawa *et al.* Perhaps the presence of a C-terminal domain is required for retroviral restriction, or perhaps TRIM5 α or TRIMCyp proteins that are not individually active against a given virus may have an undetectable binding affinity that is improved by avidity effects in a heterodimer. Future biochemical studies will help to explain the discrepancies in the data and provide a better conceptual model for TRIM5 protein interaction. Whether or not TRIM proteins heterodimerize, any of the scenarios described above would point to interesting possibilities with regard to the underlying mechanisms of TRIM5 restriction activity and regulation.

The data described here, in combination with previous *in vivo* data (Kirmaier *et al.*, 2010; Lim *et al.*, 2010c), suggest that antiretroviral TRIM5 proteins are codominant and do not interfere with each other's activity when expressed at similar levels. A codominant mode of inheritance would be advantageous from an evolutionary perspective. Individuals that express two TRIM5 proteins with different specificities would be able to restrict a broader range of viruses than homozygotes, although perhaps with decreased restriction activity against any

individual virus. This is consistent with the *in vivo* data on SIVsm and SIVmac infection in *M. mulatta* (Kirmaier et al., 2010; Lim et al., 2010c). In contrast, if TRIM5 proteins had a dominant negative effect on each other, heterozygotes would be at a severe disadvantage, as they would effectively not express any antiviral TRIM5 protein. This would presumably lead to strong selection for individual *TRIM5* alleles by any virus currently infecting these animals, and would not lead to the balancing selection seen in Old World monkey *TRIM5* (Newman et al., 2006).

Truncated mutants of TRIM5 α , as well as isoforms lacking the B30.2/SPRY domain, have consistently displayed dominant negative activity against TRIM5 α , even in a few experiments where both proteins were overexpressed (Battivelli et al., 2011a; Maegawa et al., 2008; McEwan et al., 2009; Nakajima et al., 2009; Stremlau et al., 2004; Torimiro et al., 2009; Wilson et al., 2008b). If these findings are true, why are TRIM5 isoforms lacking the B30.2 domain maintained through evolution? Recent studies have found that TRIM5 α has innate immune signaling activity, and that this signaling activity is present in TRIM5 γ as well (Pertel et al., 2011; Tareen and Emerman, 2011). This suggests that there may be a complex evolutionary calculus that has determined the relative expression levels of different TRIM5 isoforms, based on signaling activity as well as direct antiretroviral restriction.

The effects of TRIM5 protein coexpression are likely to be more complex than previously appreciated. It is possible that they may sometimes interact in a dominant negative fashion but act independently under other circumstances. It will be important to follow up these observations with more detailed analysis of the different TRIM5 isoforms expressed in different species, and their effects in combination. Careful dissection of these issues will help us to understand the determinants of susceptibility to retroviruses both in humans and in nonhuman primates.

CHAPTER 6. Conclusions

In this work, I have described several aspects of the biology of TRIM5 α and TRIMCyp in Old World primates, with a particular focus on *Macaca sylvanus* and *M. fascicularis*. *M. fascicularis* is noteworthy because of its use as a model for HIV/AIDS research, and because of the diversity of its TRIM5 restriction factors. *M. sylvanus* is of interest because of its unique evolutionary history, specifically its long isolation from other macaque species.

EVOLUTION AND GEOGRAPHIC DISTRIBUTION OF TRIM5 α AND TRIMCYP

TRIMCyp is absent in *M. sylvanus*, the most evolutionary divergent macaque species and the only macaque species found outside Asia (Dietrich et al., 2010a). However, it is present in both of the two most ancient branches of the evolutionary tree of the Asian macaques (Brennan et al., 2008; Li et al., 2009; Virgen et al., 2008; Ziegler et al., 2007). Thus, TRIMCyp must have evolved in the common ancestor of the Asian macaques after their divergence from *M. sylvanus*, approximately 5-6 million ybp. This research allows us to date the emergence of a novel restriction factor in a nonhuman primate population with unprecedented precision. It is tempting to speculate that a retrovirus infected the population at that time, driving selection for this novel restriction factor.

TRIMCyp evolved independently in the *Aotus* genus of New World primates approximately 4.5-22 million ybp. This striking example of convergent evolution suggests that TRIMCyp has played an important role in primate evolution at least twice, likely in resistance against retroviruses. *CypA* is one of the most commonly retrotransposed genes in primate genomes (Zhang et al., 2003), and this combined with its binding to retroviral capsids (Lin and Emerman, 2006; Lin and Emerman, 2008) makes it a logical target for the evolution of novel restriction factors.

I also examined the distribution of TRIMCyp both within and among Asian macaque species. I show that although TRIMCyp is fixed in *M. nemestrina* and *M. leonina*, it is not fixed in

M. nigra. Thus, the fixation event must have occurred in the common ancestor of *M. nemestrina* and *M. leonina* after their divergence from *M. nigra*, approximately 2 million ybp (Dietrich et al., 2010a; Ziegler et al., 2007). This could have occurred either through genetic drift or through selection caused by an additional virus in the *M. nemestrina/leonina* lineage.

Among the Asian macaques, *M. fascicularis* has a greater diversity of TRIM5 α and TRIMCyp proteins than any other species described to date (Dietrich et al., 2011a). In particular, I found TRIMCyp coding sequences in individuals from three of four populations tested. The exception was the population from Mauritius, which is noted for its lack of genetic diversity due to a small founding population (Krebs et al., 2005; O'Connor et al., 2010; Wiseman et al., 2007). Both TRIM5 α -expressing and TRIMCyp-expressing genotypes were present in animals from Indonesia and Indochina. TRIMCyp was present at approximately 56% allele frequency in animals of Indonesian ancestry and approximately 14% in Indochinese animals; this difference was statistically significant. Although I was only able to obtain four samples from the Philippines, I found that all four of these animals were homozygous for TRIMCyp.

Subsequent work by other groups has confirmed and extended these observations. Saito *et al.* tested individuals from Indonesia, the Philippines, and Malaysia (Saito et al., 2012). The TRIMCyp allele frequency in their Indonesian samples was 34.8%. In a larger group of animals of Philippine origin than we had access to, they found a TRIMCyp allele frequency of 87.0%, consistent with the fact that four out of four of our samples were TRIMCyp homozygotes. In Malaysian animals, TRIMCyp was present at a frequency of 48.9%. Similarly, Berry *et al.* tested animals of Mauritian and Indonesian origin. Consistent with our results, they found that TRIMCyp was not present in animals of Mauritian origin. The allele frequency of TRIMCyp in their Indonesian sample was 87% (Berry et al., 2012).

The differences in allele frequency in Indonesian populations tested in the three studies may be attributable not only to sampling bias but also to the geographic diversity of Indonesia.

The genetic characteristics of *M. fascicularis* on various Indonesian islands may be different, and this has not yet been well studied. Similarly, it would not be surprising if animals from peninsular Malaysia differed from individuals from Malaysian Borneo, or if different populations existed on different islands in the Philippines. These questions will be difficult to address fully, particularly as the majority of the macaques tested for TRIMCyp to date were colony bred in the United States, United Kingdom, or Japan. In this context, it will be important in the future to understand the geographic origin of animals used for biomedical research, and the possible implications of allelic diversity within genes such as *TRIM5* that may have an impact on the outcome of research.

FUNCTIONAL DIVERSITY OF RETROVIRAL RESTRICTION

M. fascicularis has at least two and possibly three TRIMCyp alleles with different antiretroviral specificities, adding functional diversity to the geographic diversity described above. The NE genotype at positions 369 and 446 of the CypA domain, which restricts HIV-2 but not HIV-1, is the only allele found in *M. nemestrina* and *M. mulatta* and is also found in *M. fascicularis*. The DK genotype, which restricts HIV-1 but not HIV-2, has been found only in *M. fascicularis*. The DE genotype, which restricts both viruses, was found in one *M. fascicularis* of Indonesian origin. The NK genotype has not been found in nature, and when created by mutagenesis it restricts neither HIV-1 nor HIV-2 (Dietrich et al., 2011a). Saito *et al.* were able to quantify the prevalence of the DK and NE alleles in their *M. fascicularis* samples. In all three populations they tested, the DK genotype was present at approximately 85-88% allele frequency, with the NE genotype as the minor allele; they did not find the DE or NK genotypes in their samples (Saito et al., 2012). Berry *et al.* also found only DK and NE genotypes (Berry et al., 2012). Together, these data suggest that the DE allele must be very uncommon.

In addition to the polymorphisms in the CypA domain that affect antiviral specificity, we also identified a polymorphism at position 178 in the coiled coil domain, which affects protein

abundance in CrFK cells. The specific mechanism for this effect is still unclear and will be of interest for future work. Because the coiled coil domain is involved in protein-protein interactions, it seems likely that this change affects either protein stability or toxicity in overexpressing cells. I speculate that the histidine residue at this position evolved to improve expression levels of macaque TRIMCyp (see Figure 19). However, this hypothesis remains to be tested, and it is unclear whether the effect of the polymorphism at position 178 on protein levels would be seen *in vivo*, or whether it is an artifact of expression in CrFK cells.

TRIM5 α has been more widely studied than TRIMCyp (Johnson and Sawyer, 2009). However, TRIM5 α from *M. sylvanus* had not previously been described. I show that *M. sylvanus* TRIM5 α differs from any other known TRIM5 α protein at six amino acid positions (Dietrich et al., 2010a). One of these unique residues is in a position known to be critical for retroviral restriction, and affords a unique opportunity to examine the determinants of TRIM5 α -mediated retroviral restriction. At amino acid residue 339, *M. sylvanus* TRIM5 α encodes either a threonine or a methionine residue, making its sequence either TFP or MFP at residues 339-341. In contrast, *M. mulatta* TRIM5 α encodes either TFP or Q $\Delta\Delta$ at positions 339-341. The TFP allele is able to restrict HIV-2 and SIVsm, and an animal's genotype at this position determines its susceptibility to SIVsm and related viruses (de Groot et al., 2011; Fenizia et al., 2011; Kirmaier et al., 2010; Letvin et al., 2011; Lim et al., 2010b; Lim et al., 2010c; Yeh et al., 2011). I found that the TFP allele of *M. sylvanus* TRIM5 α is capable of restricting HIV-2, but the MFP allele is not. This demonstrates that the threonine residue at position 339 is necessary for restriction of HIV-2, and thus likely the related virus SIVsm. Interestingly, however, mutagenesis of the MFP allele to encode TFP did not restore restriction of HIV-2, suggesting that other differences between the two alleles of *M. sylvanus* TRIM5 α may also play a role, and that the threonine residue at position 339 is necessary but not sufficient for restriction activity. Thus, further studies

of *M. sylvanus* TRIM5 α will shed light on additional determinants that contribute to restriction of HIV-2.

These observations help us to dissect the roles of the polymorphism at positions 339-341 in *M. mulatta*. They suggest that the two amino acid deletion seen in *M. mulatta* TRIM5 α may not be as important a factor as the absence of the threonine residue in the loss of restriction activity toward SIVsm and related viruses. This information would have been much more difficult to determine using only typical model species, as the MFP allele is unique to *M. sylvanus*.

COEXPRESSION

Typically, researchers have studied the function of TRIM5 proteins by overexpressing one TRIM5 cDNA in feline or canine cells, ensuring that only the single allele of interest will be present. These experiments have given us great insight into the function of TRIM5 proteins. However, TRIM5 function *in vivo* is likely much more complex. Even in humans, where the TRIM5 allelic diversity is relatively limited (Goldschmidt et al., 2006; Javanbakht et al., 2006; Sawyer et al., 2006; Speelman et al., 2006), multiple isoforms are expressed through alternative splicing (Battivelli et al., 2011a). The functional significance of TRIM5 isoforms other than TRIM5 α has not been thoroughly explored. In macaques, the situation is yet more complex. In addition to multiple isoforms with different C-termini, some macaques express both TRIM5 α and TRIMCyp. They may also have multiple alleles of both TRIM5 α and TRIMCyp with different antiviral specificity. Thus, it is clear that experiments testing the restriction activity of only a single TRIM5 protein, while valuable, will only give us part of the complete picture.

Early experiments suggested that TRIM5 isoforms lacking the capsid-binding B30.2/SPRY domain may have a dominant negative effect against TRIM5 α restriction (Stremlau et al., 2004). Similarly, early experiments on TRIMCyp found that it may have a dominant negative effect against TRIM5 α (Wilson et al., 2008b). However, these experiments were

performed by overexpressing the putative dominant negative protein in the context of endogenous expression of the antiviral isoform. This experimental design leads to extremely unbalanced amounts of the two proteins, which is known to lead to misleading results when studying a mechanistically similar murine restriction factor (Bock et al., 2000).

I found that the restriction activities of *M. fascicularis* TRIM5 α and TRIMCyp were functionally independent when the two proteins were coexpressed at similar levels. This finding is consistent with *in vivo* data, which seems to suggest that TRIM5 α and TRIMCyp, as well as different TRIM5 α alleles, are codominant (Kirmaier et al., 2010; Lim et al., 2010c). Conceptually, my findings are consistent with gene expression data as well as evolutionary analyses of the *TRIM5* gene. TRIM5 α makes up only approximately 50% of the *TRIM5* mRNA in human cells (Battivelli et al., 2011a), and the proportion is likely similar in nonhuman primate cells, although this has not yet been tested. If the expression of the shorter isoforms abrogated the antiviral activity of TRIM5 α , these cells would likely retain little if any TRIM5 α restriction activity. Similarly, if different antiviral TRIM5 proteins exerted a dominant negative effect on each other, heterozygotes would likely be at a strong disadvantage, and natural selection would favor homozygosity. However, on the contrary, primate *TRIM5* is subject to balancing selection, suggesting that heterozygosity is favored (Newman et al., 2006).

In the future, it will be important to explore the effects of coexpression in greater depth. What are the relative endogenous expression levels of different TRIM5 isoforms in nonhuman primates, and how does this affect their restriction activity? Does coexpression affect the innate immune signaling function of TRIM5 proteins? The implications of TRIM5 protein coexpression are not yet well understood, and this line of research will become ever more important as we continue to elucidate individual TRIM5 protein function.

IMPLICATIONS FOR AIDS MODELS

TRIM5 polymorphism plays an important role in the ability of macaques to be infected with susceptible retroviruses, and this has important implications for their use as model species for HIV/AIDS (de Groot et al., 2011; Fenizia et al., 2011; Kirmaier et al., 2010; Letvin et al., 2011; Lim et al., 2010b; Lim et al., 2010c; Yeh et al., 2011). *M. fascicularis* in particular expresses an unusually diverse array of retroviral restriction factors. Thus, it will be necessary to determine the *TRIM5* genotype of these animals and to be aware of the susceptibility of the virus of interest before beginning infection studies.

Alternatively, these issues could be avoided by using species or populations that are homogeneous at the *TRIM5* locus. For instance, Mauritian *M. fascicularis* have TRIM5 α but lack TRIMCyp (Berry et al., 2012; Dietrich et al., 2011a). Conversely, *M. nemestrina* has TRIMCyp, but apparently lacks TRIM5 α (Krebs et al., 2005; O'Connor et al., 2010; Wiseman et al., 2007). Further, *M. nemestrina* TRIMCyp is apparently relatively homogeneous compared to the functional diversity we have described in *M. fascicularis* (Newman et al., 2008; Virgen et al., 2008; A. Kirmaier, personal communication), and these animals therefore apparently lack any TRIM5-mediated restriction against HIV-1. Thus, it may be possible to infect *M. nemestrina* with HIV-1-derived viral isolates that would not be able to infect other species (Hatzioannou et al., 2006; Hatzioannou et al., 2009; Igarashi et al., 2007; Kamada et al., 2006; Pekrun et al., 2002; Saito et al., 2011; Thippeshappa et al., 2011). *M. nemestrina* may be an ideal primate species to model HIV-1 infection, as researchers continue to improve viral isolates to take advantage of our understanding of TRIM5 and other restriction factors.

FUTURE OUTLOOK

Research on the TRIM5 proteins has provided considerable insight into retroviral infection of primates, which has important implications for HIV/AIDS research. The studies reported here, along with other research in the TRIM5 field, raise numerous important questions

that will guide future research. Some of these questions could be answered relatively easily now, while others await future technological advances, such as purification of TRIM5 proteins and the development of improved antibodies to these proteins. Further exploration of these topics will allow for more insight into retroviral pathogenesis and primate evolution.

The work described here suggests several lines of inquiry related to TRIM5 α and TRIMCyp function. How does the T339M polymorphism in *M. sylvanus* TRIM5 α affect its restriction activity, and which other residues mediate the difference between the two alleles I tested? How do the polymorphisms I have described in the *M. fascicularis* and *M. sylvanus* TRIM5 genes affect their innate immune signaling function? What is the mechanistic basis for the effect of the H178Y polymorphism on TRIMCyp protein abundance, and is this effect found *in vivo*? More generally, understanding how the *in vitro* effects described here translate to the *in vivo* situation and affect viral infection in macaques is a high priority. Many different alleles and isoforms of TRIM5 are expressed in macaques; do these interact, and if so, how? Can variability in previous studies of infection using *M. fascicularis* be traced to polymorphisms in TRIM5 α and/or TRIMCyp? What evolutionary pressures led to the TRIM5 polymorphism we see today, and how does this affect extant viruses in wild macaque populations?

Purification and structural determination of TRIM5 proteins remains a desirable, if challenging, goal. If achieved, this will help us to understand the structural basis for variations in restriction activity. Structural data on the CypA domain has helped us to understand the effects of TRIMCyp polymorphisms (Caines et al., 2012; Price et al., 2009; Ylinen et al., 2010), and similar data on TRIM5 α would be extremely valuable. Continued work in this area, as well as efforts to determine the structure of TRIM5 α , will help us to understand the structural basis for the variations in restriction activity.

It will be of interest to continue to explore TRIM5 gene sequence and function in additional primate species that are not commonly used in biomedical research. These studies

will not only answer basic evolutionary questions, but may also help us to understand restriction in model species used for HIV/AIDS research. I show here that TRIMCyp is absent in single individuals of *M. nigra* and *M. thibetana*, but it remains to be determined whether TRIMCyp is present in other individuals of these species. Many other macaque species have not been examined at all. A further understanding of the distribution of TRIMCyp among macaque species will help to clarify the evolution of this protein and may reveal additional functional diversity. Similarly, just as examining *M. sylvanus* TRIM5 α gave us insight into the determinants of retroviral restriction by *M. mulatta* TRIM5 α , other polymorphisms in non-model species may help us to understand the potential specificity and variability of TRIM5 restriction factors.

Another important under-researched area is the *in vivo* expression of TRIM5 proteins. The relative RNA expression of TRIM5 isoforms has been studied in humans (Battivelli et al., 2011a), but not in nonhuman primates. The lack of suitable antibodies has limited the information that can be gained about endogenous TRIM5 protein expression. However, RNA expression data is attainable but has not yet been thoroughly examined. For analysis of TRIM5 protein function, one exciting possibility is to perform siRNA knockdown experiments in primary nonhuman primate cell lines. Such experiments will allow us to ascertain the contribution of individual TRIM5 isoforms to retroviral infection without the use of tagged overexpression systems.

Additional TRIM5 splice isoforms remain to be described fully, particularly in macaques that express TRIMCyp (data not shown and A. Kirmaier, personal communication). The function of isoforms other than TRIM5 α and TRIMCyp, if any, is unclear. TRIM5 γ , at least, has innate immune signaling activity, and this is likely true of other isoforms as well (Pertel et al., 2011). Based on the idea that they have dominant negative activity against TRIM5 α , it has been suggested that TRIM5 isoforms lacking C-terminal capsid-binding domains may act to regulate TRIM5 α activity (Towers, 2007). TRIM5 proteins may also have other functions that remain to

be described. The functions, interactions, and relative expression levels of the various TRIM5 proteins, both in humans and in nonhuman primates, will be an important avenue for research in the future.

The discovery of the signaling function of TRIM5 proteins has opened up many exciting possibilities for research (Pertel et al., 2011; Tareen et al., 2011). No one has yet tested for NF- κ B/AP-1 signaling ability in *M. fascicularis* TRIM5 α , or any Old World primate TRIMCyp (Pertel et al., 2011). It is possible that some of the polymorphisms in *M. fascicularis* TRIMCyp identified here will affect signaling function. I identified several polymorphisms that did not have an identifiable effect on restriction activity, including some in the RING and B-Box domains, and it will be of interest to test these variants for signaling capability. None of these residues has been identified as being under positive selection; however, it is possible that they may have a TRIMCyp-specific effect, like the Y178H polymorphism, or an effect that was not detected in evolutionary analysis (Sawyer et al., 2005).

Eventually, the study of TRIM5 and other restriction factors should lead to improved animal models for HIV/AIDS. Infection of macaques with SIV or related recombinants currently represents the best available compromise between ease of use and accurate modeling of human AIDS. However, these models are imperfect, and further progress in preclinical AIDS research will require further improvement. New viral isolates that more closely mimic HIV-1 while still being able to infect macaques have been made possible by research into restriction factors (Hatzioannou et al., 2006; Hatzioannou et al., 2009; Igarashi et al., 2007; Kamada et al., 2006; Pekrun et al., 2002; Saito et al., 2011; Thippeshappa et al., 2011). More improvements will certainly follow as these models continue to be refined, both empirically (e.g. Kamada et al., 2006) and through improved understanding of restriction factors. No viral isolate has yet been reported to mimic HIV-1 infection in macaques while taking tetherin into account,

for instance, and there may also be other restriction factors not yet described that will affect the ability of macaques to be infected by HIV-1 and related viruses.

IMPORTANCE OF RESTRICTION FACTORS

Study of the restriction factors has vastly improved our understanding of retroviral pathogenesis, and likely more remain to be discovered. The TRIM5 proteins have helped us to understand the barriers to cross-species transmission of retroviruses, as well as the uncoating process and the role of the capsid in the early steps of viral replication (Towers, 2007).

Research into other restriction factors, such as the APOBEC3 proteins, has provided other insights into retroviral pathogenesis and the role of the viral accessory proteins. The discovery of tetherin has led to important research on the budding step of the retroviral life cycle, and the recent discovery of SAMHD1 will likely provide insight into differences in cell tropism among different viral isolates. Doubtless future research into restriction factors will open up new lines of research not yet imagined.

Research on TRIM5 has also given us insight into the immune system. Early in the history of the field, restriction factors were hailed as belonging to a third branch of the immune system that was independent of innate and adaptive immunity (Bieniasz, 2004). However, it has become clear that this view is too simplistic, and that TRIM5 is intimately connected with the innate immune system. Like other restriction factors, it is upregulated by interferon signaling (Asaoka et al., 2005; Carthagena et al., 2008; Neil and Bieniasz, 2009; Sakuma et al., 2007a). However, the connection is deeper than this, as TRIM5 α itself participates in innate immune signaling in response to either retroviral infection or interferon signaling (Pertel et al., 2011; Tareen and Emerman, 2011). Thus, although the distinctions between intrinsic and innate immunity may provide a useful theoretical framework, it is also clear that they are at least somewhat artificial, and it seems likely that more interconnections will be found as research progresses.

Study of restriction factors, and particularly the *TRIM5* gene and the multiple proteins it encodes, have proved extremely useful to our understanding of viral pathogenesis, primate evolution, the immune system, and HIV/AIDS. The work described here has expanded our understanding of the role of TRIM5 in primate evolution, its functional diversity, and its effects on retroviral infection. This work also lays the foundation for further inquiry into the *in vivo* effects of these restriction factors and their potential interactions.

REFERENCES

- Ambrose, Z., KewalRamani, V.N., Bieniasz, P.D., and Hatziioannou, T. (2007). HIV/AIDS: in search of an animal model. *Trends Biotechnol.* *25*, 333-337.
- Anderson, J.L., Campbell, E.M., Wu, X., Vandegraaff, N., Engelman, A., and Hope, T.J. (2006). Proteasome inhibition reveals that a functional preintegration complex intermediate can be generated during restriction by diverse TRIM5 proteins. *J. Virol.* *80*, 9754-9760.
- Asaoka, K., Ikeda, K., Hishinuma, T., Horie-Inoue, K., Takeda, S., and Inoue, S. (2005). A retrovirus restriction factor TRIM5 α is transcriptionally regulated by interferons. *Biochem. Biophys. Res. Commun.* *338*, 1950-1956.
- Baroncelli, S., Negri, D.R., Michelini, Z., and Cara, A. (2008). *Macaca mulatta*, *fascicularis* and *nemestrina* in AIDS vaccine development. *Expert Rev. Vaccines* *7*, 1419-1434.
- Barr, S.D., Smiley, J.R., and Bushman, F.D. (2008). The interferon response inhibits HIV particle production by induction of TRIM22. *PLoS Pathog.* *4*, e1000007.
- Battivelli, E., Migraine, J., Lecossier, D., Matsuoka, S., Perez-Bercoff, D., Saragosti, S., Clavel, F., and Hance, A.J. (2011a). Modulation of TRIM5 α Activity in Human Cells by Alternatively Spliced TRIM5 Isoforms. *J. Virol.* *85*, 7828-7835.
- Battivelli, E., Migraine, J., Lecossier, D., Yeni, P., Clavel, F., and Hance, A.J. (2011b). Gag Cytotoxic T Lymphocyte Escape Mutations Can Increase Sensitivity of HIV-1 to Human TRIM5 α , Linking Intrinsic and Acquired Immunity. *J. Virol.* *85*, 11846-11854.
- Berry, N.J., Marzetta, F., Towers, G.J., and Rose, N.J. (2012). Diversity of TRIM5 α and TRIMCyp sequences in cynomolgus macaques from different geographical origins. *Immunogenetics* *64*, 267-278.
- Berthou, L., Sebastian, S., Sokolskaja, E., and Luban, J. (2005). Cyclophilin A is required for TRIM5 α -mediated resistance to HIV-1 in Old World monkey cells. *Proc. Natl. Acad. Sci. U. S. A.* *102*, 14849-14853.
- Bieniasz, P.D. (2004). Intrinsic immunity: a front-line defense against viral attack. *Nat. Immunol.* *5*, 1109-1115.
- Black, L.R., and Aiken, C. (2010). TRIM5 α disrupts the structure of assembled HIV-1 capsid complexes in vitro. *J. Virol.* *84*, 6564-6569.
- Blondel, D., Kheddache, S., Lahaye, X., Dianoux, L., and Chelbi-Alix, M.K. (2010). Resistance to Rabies Virus Infection Conferred by the PMLIV Isoform. *J. Virol.* *84*, 10719-10726.
- Bock, M., Bishop, K.N., Towers, G., and Stoye, J.P. (2000). Use of a transient assay for studying the genetic determinants of Fv1 restriction. *J. Virol.* *74*, 7422-7430.
- Bonhomme, M., Cuartero, S., Blancher, A., and Crouau-Roy, B. (2009). Assessing natural introgression in 2 biomedical model species, the rhesus macaque (*Macaca mulatta*) and the long-tailed macaque (*Macaca fascicularis*). *J. Hered.* *100*, 158-169.
- Brennan, G., Kozyrev, Y., and Hu, S.L. (2008). TRIMCyp expression in Old World primates *Macaca nemestrina* and *Macaca fascicularis*. *Proc. Natl. Acad. Sci. U. S. A.* *105*, 3569-3574.

- Brennan, G., Kozyrev, Y., Kodama, T., and Hu, S.L. (2007). Novel TRIM5 isoforms expressed by *Macaca nemestrina*. *J. Virol.* *81*, 12210-12217.
- Cafaro, A., Bellino, S., Titti, F., Maggiorella, M.T., Sernicola, L., Wiseman, R.W., Venzon, D., Karl, J.A., O'Connor, D., Monini, P., Robert-Guroff, M., and Ensoli, B. (2010). Impact of viral dose and major histocompatibility complex class IB haplotype on viral outcome in Mauritian cynomolgus monkeys vaccinated with Tat upon challenge with simian/human immunodeficiency virus SHIV89.6P. *J. Virol.* *84*, 8953-8958.
- Caines, M.E., Bichel, K., Price, A.J., McEwan, W.A., Towers, G.J., Willett, B.J., Freund, S.M., and James, L.C. (2012). Diverse HIV viruses are targeted by a conformationally dynamic antiviral. *Nat. Struct. Mol. Biol.* *19*, 411-416.
- Campbell, E.M., Perez, O., Anderson, J.L., and Hope, T.J. (2008). Visualization of a proteasome-independent intermediate during restriction of HIV-1 by rhesus TRIM5 α . *J. Cell Biol.* *180*, 549-561.
- Carthagen, L., Parise, M.C., Ringeard, M., Chelbi-Alix, M.K., Hazan, U., and Nisole, S. (2008). Implication of TRIM alpha and TRIMCyp in interferon-induced anti-retroviral restriction activities. *Retrovirology* *5*, 59.
- Chae, J.J., Aksenitjevich, I., and Kastner, D.L. (2009). Advances in the understanding of familial Mediterranean fever and possibilities for targeted therapy. *Br. J. Haematol.* *146*, 467-478.
- Cowan, S., Hatzioannou, T., Cunningham, T., Muesing, M.A., Gottlinger, H.G., and Bieniasz, P.D. (2002). Cellular inhibitors with Fv1-like activity restrict human and simian immunodeficiency virus tropism. *Proc. Natl. Acad. Sci. U.S.A.* *99*, 11914-11919.
- de Groot, N.G., Heijmans, C.M.C., Koopman, G., Verschoor, E.J., Bogers, W.M., and Bontrop, R.E. (2011). TRIM5 allelic polymorphism in macaque species/populations of different geographic origins: its impact on SIV vaccine studies. *Tissue Antigens* *78*, 256-262.
- Delson, E. (1996) The oldest monkeys in Asia. In *International Symposium: Evolution of Asian Primates*. (Freude and Kyoto University Primate Research Institute, Inuyama, Aichi, Japan: Inuyama, Aichi, Japan), pp. 40.
- Diaz-Griffero, F., Li, X., Javanbakht, H., Song, B., Welikala, S., Stremlau, M., and Sodroski, J. (2006). Rapid turnover and polyubiquitylation of the retroviral restriction factor TRIM5. *Virology* *349*, 300-315.
- Diaz-Griffero, F., Qin, X.R., Hayashi, F., Kigawa, T., Finzi, A., Sarnak, Z., Lienlaf, M., Yokoyama, S., and Sodroski, J. (2009). A B-box 2 surface patch important for TRIM5 α self-association, capsid binding avidity, and retrovirus restriction. *J. Virol.* *83*, 10737-10751.
- Dietrich, E.A., Jones-Engel, L., and Hu, S.L. (2010a). Evolution of the Antiretroviral Restriction Factor TRIMCyp in Old World Primates. *PLoS One* *5*, e14019.
- Dietrich, E.A., Brennan, G., Ferguson, B., Wiseman, R.W., O'Connor, D., and Hu, S. (2011a). Variable prevalence and functional diversity of the antiretroviral restriction factor TRIMCyp in *Macaca fascicularis*. *J. Virol.* *85*, 9956-9963.
- Dietrich, I., McEwan, W.A., Hosie, M.J., and Willett, B.J. (2011b). Restriction of the felid lentiviruses by a synthetic feline TRIM5-CypA fusion. *Vet. Immunol. Immunopathol.* *143*, 235-242.

- Dietrich, I., Macintyre, A., McMonagle, E., Price, A.J., James, L.C., McEwan, W.A., Hosie, M.J., and Willett, B.J. (2010b). Potent Lentiviral Restriction by a Synthetic Feline TRIM5 Cyclophilin A Fusion. *J. Virol.* *84*, 8980-8985.
- Drummond, A.J., Ashton, B., Cheung, M., Heled, J., Kearse, M., Moir, R., Stones-Havas, S., Thierer, T., and Wilson, A. (2009). Geneious 4.8. Available from <http://www.geneious.com>
- Emerman, M., and Malik, H.S. (2010). Paleovirology--modern consequences of ancient viruses. *PLoS Biol.* *8*, e1000301.
- Engel, G.A., Pizarro, M., Shaw, E., Cortes, J., Fuentes, A., Barry, P., Lerche, N., Grant, R., Cohn, D., and Jones-Engel, L. (2008). Unique pattern of enzootic primate viruses in Gibraltar macaques. *Emerg. Infect. Dis.* *14*, 1112-1115.
- Espinosa, A., Dardalhon, V., Brauner, S., Ambrosi, A., Higgs, R., Quintana, F.J., Sjostrand, M., Eloranta, M.L., Ni Gabhann, J., Winqvist, O., *et al.* (2009). Loss of the lupus autoantigen Ro52/Trim21 induces tissue inflammation and systemic autoimmunity by dysregulating the IL-23-Th17 pathway. *J. Exp. Med.* *206*, 1661-1671.
- Fenizia, C., Keele, B.F., Nichols, D., Cornara, S., Binello, N., Vaccari, M., Pegu, P., Robert-Guroff, M., Ma, Z., Miller, C.J., *et al.* (2011). TRIM5 α Does Not Affect Simian Immunodeficiency Virus SIVmac251 Replication in Vaccinated or Unvaccinated Indian Rhesus Macaques following Intrarectal Challenge Exposure. *J. Virol.* *85*, 12399-12409.
- Fletcher, A.J., Hue, S., Schaller, T., Pillay, D., and Towers, G.J. (2010). Hare TRIM5 α Restricts Divergent Retroviruses and Exhibits Significant Sequence Variation from Closely Related Lagomorpha TRIM5 Genes. *J. Virol.* *84*, 12463-12468.
- Gack, M.U., Albrecht, R.A., Urano, T., Inn, K.S., Huang, I.C., Carnero, E., Farzan, M., Inoue, S., Jung, J.U., and Garcia-Sastre, A. (2009). Influenza A virus NS1 targets the ubiquitin ligase TRIM25 to evade recognition by the host viral RNA sensor RIG-I. *Cell. Host Microbe* *5*, 439-449.
- Gack, M.U., Shin, Y.C., Joo, C.H., Urano, T., Liang, C., Sun, L., Takeuchi, O., Akira, S., Chen, Z., Inoue, S., and Jung, J.U. (2007). TRIM25 RING-finger E3 ubiquitin ligase is essential for RIG-I-mediated antiviral activity. *Nature* *446*, 916-920.
- Ganser-Pornillos, B.K., Chandrasekaran, V., Pornillos, O., Sodroski, J.G., Sundquist, W.I., and Yeager, M. (2011). Hexagonal assembly of a restricting TRIM5 α protein. *Proc. Natl. Acad. Sci. U. S. A.* *108*, 534-539.
- Geoffroy, M.C., and Chelbi-Alix, M.K. (2011). Role of promyelocytic leukemia protein in host antiviral defense. *J. Interferon Cytokine Res.* *31*, 145-158.
- Goff, S.P. (2004). Retrovirus restriction factors. *Mol. Cell* *16*, 849-859.
- Goldschmidt, V., Bleiber, G., May, M., Martinez, R., Ortiz, M., Telenti, A., and The Swiss HIV Cohort Study. (2006). Role of common human TRIM5 α variants in HIV-1 disease progression. *Retrovirology* *3*, 54.
- Goldstone, D.C., Ennis-Adeniran, V., Hedden, J.J., Groom, H.C., Rice, G.I., Christodoulou, E., Walker, P.A., Kelly, G., Haire, L.F., Yap, M.W., *et al.* (2011). HIV-1 restriction factor SAMHD1 is a deoxynucleoside triphosphate triphosphohydrolase. *Nature* *480*, 379-382.

- Grandemange, S., Aksentijevich, I., Jeru, I., Gul, A., and Touitou, I. (2011). The regulation of MEFV expression and its role in health and familial Mediterranean fever. *Genes Immun.* *12*, 497-503.
- Han, K., Lou, D.I., and Sawyer, S.L. (2011). Identification of a genomic reservoir for new TRIM genes in primate genomes. *PLoS Genet.* *7*, e1002388.
- Harris, R.S., Bishop, K.N., Sheehy, A.M., Craig, H.M., Petersen-Mahrt, S.K., Watt, I.N., Neuberger, M.S., and Malim, M.H. (2003). DNA Deamination Mediates Innate Immunity to Retroviral Infection. *Cell* *113*, 803-809.
- Hatzioannou, T., Princiotta, M., Piatak, M., Jr, Yuan, F., Zhang, F., Lifson, J.D., and Bieniasz, P.D. (2006). Generation of simian-tropic HIV-1 by restriction factor evasion. *Science* *314*, 95.
- Hatzioannou, T., Ambrose, Z., Chung, N.P.Y., Piatak, M., Yuan, F., Trubey, C.M., Coalter, V., Kiser, R., Schneider, D., Smedley, J., *et al.* (2009). A macaque model of HIV-1 infection. *Proc. Natl. Acad. Sci. U.S.A.* *106*, 4425-4429.
- Hatzioannou, T., Perez-Caballero, D., Yang, A., Cowan, S., and Bieniasz, P.D. (2004). Retrovirus resistance factors Ref1 and Lv1 are species-specific variants of TRIM5 α . *Proc. Natl. Acad. Sci. U.S.A.* *101*, 10774-10779.
- Hrecka, K., Hao, C., Gierszewska, M., Swanson, S.K., Kesik-Brodacka, M., Srivastava, S., Florens, L., Washburn, M.P., and Skowronski, J. (2011). Vpx relieves inhibition of HIV-1 infection of macrophages mediated by the SAMHD1 protein. *Nature* *474*, 658-661.
- Igarashi, T., Iyengar, R., Byrum, R.A., Buckler-White, A., Dewar, R.L., Buckler, C.E., Lane, H.C., Kamada, K., Adachi, A., and Martin, M.A. (2007). Human immunodeficiency virus type 1 derivative with 7% simian immunodeficiency virus genetic content is able to establish infections in pig-tailed macaques. *J. Virol.* *81*, 11549-11552.
- Javanbakht, H., An, P., Gold, B., Petersen, D.C., O'Huigin, C., Nelson, G.W., O'Brien, S.J., Kirk, G.D., Detels, R., Buchbinder, S., *et al.* (2006). Effects of human TRIM5 α polymorphisms on antiretroviral function and susceptibility to human immunodeficiency virus infection. *Virology* *354*, 15-27.
- Javanbakht, H., Diaz-Griffero, F., Stremlau, M., Si, Z., and Sodroski, J. (2005). The contribution of RING and B-box 2 domains to retroviral restriction mediated by monkey TRIM5 α . *J. Biol. Chem.* *280*, 26933-26940.
- Javanbakht, H., Diaz-Griffero, F., Yuan, W., Yeung, D.F., Li, X., Song, B., and Sodroski, J. (2007). The ability of multimerized cyclophilin A to restrict retrovirus infection. *Virology* *367*, 19-29.
- Javanbakht, H., Yuan, W., Yeung, D.F., Song, B., Diaz-Griffero, F., Li, Y., Li, X., Stremlau, M., and Sodroski, J. (2006). Characterization of TRIM5 α trimerization and its contribution to human immunodeficiency virus capsid binding. *Virology* *353*, 234-246.
- Jefferies, C., Wynne, C., and Higgs, R. (2011). Antiviral TRIMs: friend or foe in autoimmune and autoinflammatory disease? *Nat. Rev. Immunol.* *11*, 617-625.
- Jia, B., Serra-Moreno, R., Neidermyer, W., Rahmberg, A., Mackey, J., Fofana, I.B., Johnson, W.E., Westmoreland, S., and Evans, D.T. (2009). Species-specific activity of SIV Nef and HIV-1 Vpu in overcoming restriction by tetherin/BST2. *PLoS Pathog.* *5*, e1000429.

- Johnson, W.E., and Sawyer, S.L. (2009). Molecular evolution of the antiretroviral TRIM5 gene. *Immunogenetics* 61, 163-176.
- Kaiser, S.M., Malik, H.S., and Emerman, M. (2007). Restriction of an extinct retrovirus by the human TRIM5alpha antiviral protein. *Science* 316, 1756-1758.
- Kamada, K., Igarashi, T., Martin, M.A., Khamsri, B., Hatcho, K., Yamashita, T., Fujita, M., Uchiyama, T., and Adachi, A. (2006). Generation of HIV-1 derivatives that productively infect macaque monkey lymphoid cells. *Proc. Natl. Acad. Sci. U. S. A.* 103, 16959-16964.
- Kanthaswamy, S., Satkoski, J., George, D., Kou, A., Erickson, B.J., and Smith, D.G. (2008). Hybridization and Stratification of Nuclear Genetic Variation in *Macaca mulatta* and *M. fascicularis*. *Int. J. Primatol.* 29, 1295-1311.
- Kar, A.K., Mao, Y., Bird, G., Walensky, L., and Sodroski, J. (2011). Characterization of a core fragment of the rhesus monkey TRIM5alpha protein. *BMC Biochem.* 12, 1.
- Keckesova, Z., Ylinen, L.M.J., and Towers, G.J. (2004). The human and African green monkey TRIM5 α genes encode Ref1 and Lv1 retroviral restriction factor activities. *Proc. Natl. Acad. Sci. U.S.A.* 101, 10780-10785.
- Kentsis, A., Dwyer, E.C., Perez, J.M., Sharma, M., Chen, A., Pan, Z.Q., and Borden, K.L.B. (2001). The RING domains of the promyelocytic leukemia protein PML and the arenaviral protein Z repress translation by directly inhibiting translation initiation factor eIF4E. *J. Mol. Biol.*, 312, 609-623.
- Kim, J., Tipper, C., and Sodroski, J. (2011). Role of TRIM5 α RING Domain E3 Ubiquitin Ligase Activity in Capsid Disassembly, Reverse Transcription Blockade, and Restriction of Simian Immunodeficiency Virus. *J. Virol.* 85, 8116-8132.
- Kirmaier, A., Wu, F., Newman, R.M., Hall, L.R., Morgan, J.S., O'Connor, S., Marx, P.A., Meythaler, M., Goldstein, S., Buckler-White, A., *et al.* (2010). *TRIM5* Suppresses Cross-Species Transmission of a Primate Immunodeficiency Virus and Selects for Emergence of Resistant Variants in the New Species. *PLoS Biol* 8, e1000462.
- Kohler, M., Moya-Sola, S., and Alba, D.M. (2000). *Macaca* (Primates, Cercopithecidae) from the late Miocene of Spain. *J. Hum. Evol.* 38, 447-452.
- Kono, K., Song, H., Shingai, Y., Shioda, T., and Nakayama, E.E. (2008). Comparison of anti-viral activity of rhesus monkey and cynomolgus monkey TRIM5alphas against human immunodeficiency virus type 2 infection. *Virology* 373, 447-456.
- Kootstra, N.A., Navis, M., Beugeling, C., van Dort, K.A., and Schuitemaker, H. (2007). The presence of the Trim5alpha escape mutation H87Q in the capsid of late stage HIV-1 variants is preceded by a prolonged asymptomatic infection phase. *AIDS* 21, 2015-2023.
- Krebs, K.C., Jin, Z., Rudersdorf, R., Hughes, A.L., and O'Connor, D.H. (2005). Unusually High Frequency MHC Class I Alleles in Mauritian Origin Cynomolgus Macaques. *J. Immunol.* 175, 5230-5239.
- Kuang, Y., Tang, X., Liu, F., Jiang, X., Zhang, Y., Gao, G., and Zheng, Y. (2009). Genotyping of TRIM5 locus in northern pig-tailed macaques (*Macaca leonina*), a primate species susceptible to Human Immunodeficiency Virus type 1 infection. *Retrovirology* 6, 58.
- Laguette, N., and Benkirane, M. (2012). How SAMHD1 changes our view of viral restriction. *Trends Immunol.* 33, 26-33.

- Laguet, N., Sobhian, B., Casartelli, N., Ringeard, M., Chable-Bessia, C., Segeral, E., Yatim, A., Emiliani, S., Schwartz, O., and Benkirane, M. (2011). SAMHD1 is the dendritic- and myeloid-cell-specific HIV-1 restriction factor counteracted by Vpx. *Nature* 474, 654-657.
- Langelier, C.R., Sandrin, V., Eckert, D.M., Christensen, D.E., Chandrasekaran, V., Alam, S.L., Aiken, C., Olsen, J.C., Kar, A.K., Sodroski, J.G., and Sundquist, W.I. (2008). Biochemical characterization of a recombinant TRIM5 α protein that restricts human immunodeficiency virus type 1 replication. *J. Virol.* 82, 11682-11694.
- Le Tortorec, A., and Neil, S.J. (2009). Antagonism to and intracellular sequestration of human tetherin by the human immunodeficiency virus type 2 envelope glycoprotein. *J. Virol.* 83, 11966-11978.
- Letvin, N.L., Rao, S.S., Montefiori, D.C., Seaman, M.S., Sun, Y., Lim, S.Y., Yeh, W.W., Asmal, M., Gelman, R.S., Shen, L., *et al.* (2011). Immune and Genetic Correlates of Vaccine Protection Against Mucosal Infection by SIV in Monkeys. *Sci. Transl. Med.* 3, 81ra36.
- Li, J., Han, K., Xing, J., Kim, H.S., Rogers, J., Ryder, O.A., Disotell, T., Yue, B., and Batzer, M.A. (2009). Phylogeny of the macaques (Cercopithecidae: *Macaca*) based on Alu elements. *Gene* 448, 242-249.
- Li, X., and Sodroski, J. (2008). The TRIM5 α B-Box 2 Domain Promotes Cooperative Binding to the Retroviral Capsid by Mediating Higher-Order Self-Association. *J. Virol.* 82, 11495-11502.
- Li, X., Yeung, D.F., Fiengen, A.M., and Sodroski, J. (2011). Determinants of the Higher Order Association of the Restriction Factor TRIM5 α and Other Tripartite Motif (TRIM) Proteins. *J. Biol. Chem.* 286, 27959-27970.
- Li, Y., Li, X., Stremlau, M., Lee, M., and Sodroski, J. (2006). Removal of arginine 332 allows human TRIM5 α to bind human immunodeficiency virus capsids and to restrict infection. *J. Virol.* 80, 6738-6744.
- Liao, C.H., Kuang, Y.Q., Liu, H.L., Zheng, Y.T., and Su, B. (2007). A novel fusion gene, TRIM5-Cyclophilin A in the pig-tailed macaque determines its susceptibility to HIV-1 infection. *AIDS* 21 *Suppl* 8, S19-26.
- Lienlaf, M., Hayashi, F., Di Nunzio, F., Tochio, N., Kigawa, T., Yokoyama, S., and Diaz-Griffero, F. (2011). Contribution of E3-Ubiquitin Ligase Activity to HIV-1 Restriction by TRIM5 α : Structure of the RING Domain of TRIM5 α . *J. Virol.* 85, 8725-8737.
- Lim, E.S., Malik, H.S., and Emerman, M. (2010a). Ancient adaptive evolution of tetherin shaped the functions of Vpu and Nef in human immunodeficiency virus and primate lentiviruses. *J. Virol.* 84, 7124-7134.
- Lim, S.Y., Chan, T., Gelman, R.S., Whitney, J.B., O'Brien, K.L., Barouch, D.H., Goldstein, D.B., Haynes, B.F., and Letvin, N.L. (2010b). Contributions of Mamu-A*01 status and TRIM5 allele expression, but not CCL3L copy number variation, to the control of SIVmac251 replication in Indian-origin rhesus monkeys. *PLoS Genet.* 6, e1000997.
- Lim, S.Y., Rogers, T., Chan, T., Whitney, J.B., Kim, J., Sodroski, J., and Letvin, N.L. (2010c). TRIM5 α Modulates Immunodeficiency Virus Control in Rhesus Monkeys. *PLoS Pathog.* 6, e1000738.
- Lin, T.Y., and Emerman, M. (2008). Determinants of cyclophilin A-dependent TRIM5 α restriction against HIV-1. *Virology* 379, 335-341.

- Lin, T.Y., and Emerman, M. (2006). Cyclophilin A interacts with diverse lentiviral capsids. *Retrovirology* 3, 70.
- Liu, F.L., Qiu, Y.Q., Li, H., Kuang, Y.Q., Tang, X., Cao, G., Tang, N.L., and Zheng, Y.T. (2011). An HIV-1 resistance polymorphism in TRIM5alpha gene among Chinese intravenous drug users. *J. Acquir. Immune Defic. Syndr.* 56, 306-311.
- Liu, H.L., Wang, Y.Q., Liao, C.H., Kuang, Y.Q., Zheng, Y.T., and Su, B. (2005). Adaptive evolution of primate TRIM5alpha, a gene restricting HIV-1 infection. *Gene* 362, 109-116.
- Luban, J. (2007). Cyclophilin A, TRIM5, and Resistance to Human Immunodeficiency Virus Type 1 Infection. *J. Virol.* 81, 1054-1061.
- Luban, J., Bossolt, K.L., Franke, E.K., Kalpana, G.V., and Goff, S.P. (1993). Human immunodeficiency virus type 1 Gag protein binds to cyclophilins A and B. *Cell*, 73, 1067-1078.
- Maegawa, H., Nakayama, E.E., Kuroishi, A., and Shioda, T. (2008). Silencing of tripartite motif protein (TRIM) 5alpha mediated anti-HIV-1 activity by truncated mutant of TRIM5alpha. *J. Virol. Methods* 151, 249-256.
- Maegawa, H., Miyamoto, T., Sakuragi, J., Shioda, T., and Nakayama, E.E. (2010). Contribution of RING domain to retrovirus restriction by TRIM5 α depends on combination of host and virus. *Virology* 399, 212-220.
- Maillard, P.V., Ecco, G., Ortiz, M., and Trono, D. (2010). The Specificity of TRIM5 α -Mediated Restriction Is Influenced by Its Coiled-Coil Domain. *J. Virol.* 84, 5790-5801.
- Mallery, D.L., McEwan, W.A., Bidgood, S.R., Towers, G.J., Johnson, C.M., and James, L.C. (2010). Antibodies mediate intracellular immunity through tripartite motif-containing 21 (TRIM21). *Proc. Natl. Acad. Sci. U.S.A.* 107, 19985-19990.
- Maroui, M.A., Pampin, M., and Chelbi-Alix, M.K. (2011). Promyelocytic Leukemia Isoform IV Confers Resistance to Encephalomyocarditis Virus via the Sequestration of 3D Polymerase in Nuclear Bodies. *J. Virol.* 85, 13164-13173.
- Matsuoka, S., Dam, E., Lecossier, D., Clavel, F., and Hance, A.J. (2009). Modulation of HIV-1 infectivity and cyclophilin A-dependence by Gag sequence and target cell type. *Retrovirology* 6, 21.
- McEwan, W.A., Schaller, T., Ylinen, L.M., Hosie, M.J., Towers, G.J., and Willett, B.J. (2009). Truncation of TRIM5 in the Feliformia Explains the Absence of Retroviral Restriction in Cells of the Domestic Cat. *J. Virol.* 83, 8270-8275.
- McNab, F.W., Rajsbaum, R., Stoye, J.P., and O'Garra, A. (2011). Tripartite-motif proteins and innate immune regulation. *Curr. Opin. Immunol.* 23, 46-56.
- Mische, C.C., Javanbakht, H., Song, B., Diaz-Griffero, F., Stremlau, M., Strack, B., Si, Z., and Sodroski, J. (2005). Retroviral restriction factor TRIM5alpha is a trimer. *J. Virol.* 79, 14446-14450.
- Modolo, L., Salzburger, W., and Martin, R.D. (2005). Phylogeography of Barbary macaques (*Macaca sylvanus*) and the origin of the Gibraltar colony. *Proc. Natl. Acad. Sci. U.S.A.* 102, 7392-7397.
- Nakajima, T., Nakayama, E.E., Kaur, G., Terunuma, H., Mimaya, J.I., Ohtani, H., Mehra, N., Shioda, T., and Kimura, A. (2009). Impact of novel TRIM5alpha variants, Gly110Arg and

- G176del, on the anti-HIV-1 activity and the susceptibility to HIV-1 infection. *AIDS* 23, 2091-2100.
- Nakayama, E.E., Carpentier, W., Costagliola, D., Shioda, T., Iwamoto, A., Debre, P., Yoshimura, K., Autran, B., Matsushita, S., and Theodorou, I. (2007). Wild type and H43Y variant of human TRIM5alpha show similar anti-human immunodeficiency virus type 1 activity both in vivo and in vitro. *Immunogenetics* 59, 511-515.
- Nakayama, E.E., Miyoshi, H., Nagai, Y., and Shioda, T. (2005). A specific region of 37 amino acid residues in the SPRY (B30.2) domain of African green monkey TRIM5alpha determines species-specific restriction of simian immunodeficiency virus SIVmac infection. *J. Virol.* 79, 8870-8877.
- Neagu, M.R., Ziegler, P., Pertel, T., Strambio-De-Castillia, C., Grutter, C., Martinetti, G., Mazzucchelli, L., Grutter, M., Manz, M.G., and Luban, J. (2009). Potent inhibition of HIV-1 by TRIM5-cyclophilin fusion proteins engineered from human components. *J. Clin. Invest.* 119, 3035-3047.
- Neil, S., and Bieniasz, P. (2009). Human immunodeficiency virus, restriction factors, and interferon. *J. Interferon Cytokine Res.* 29, 569-580.
- Neil, S.J., Zang, T., and Bieniasz, P.D. (2008). Tetherin inhibits retrovirus release and is antagonized by HIV-1 Vpu. *Nature* 451, 425-430.
- Newman, R.M., Hall, L., Connole, M., Chen, G.L., Sato, S., Yuste, E., Diehl, W., Hunter, E., Kaur, A., Miller, G.M., and Johnson, W.E. (2006). Balancing selection and the evolution of functional polymorphism in Old World monkey TRIM5alpha. *Proc. Natl. Acad. Sci. U. S. A.* 103, 19134-19139.
- Newman, R.M., Hall, L., Kirmaier, A., Pozzi, L.A., Pery, E., Farzan, M., O'Neil, S.P., and Johnson, W. (2008). Evolution of a TRIM5-CypA splice isoform in Old World monkeys. *PLoS Pathog.* 4, e1000003.
- Nisole, S., Lynch, C., Stoye, J.P., and Yap, M.W. (2004). A Trim5-cyclophilin A fusion protein found in owl monkey kidney cells can restrict HIV-1. *Proc. Natl. Acad. Sci. U. S. A.* 101, 13324-13328.
- Nisole, S., Stoye, J.P., and Saib, A. (2005). TRIM family proteins: retroviral restriction and antiviral defence. *Nat. Rev. Microbiol.* 3, 799-808.
- O'Connor, S.L., Lhost, J.J., Becker, E.A., Detmer, A.M., Johnson, R.C., MacNair, C.E., Wiseman, R.W., Karl, J.A., Greene, J.M., Burwitz, B.J., *et al.* (2010). MHC Heterozygote Advantage in Simian Immunodeficiency Virus-Infected Mauritian Cynomolgus Macaques. *Sci. Transl. Med.* 2, 22ra18-22ra18.
- Ohkura, S., Yap, M.W., Sheldon, T., and Stoye, J.P. (2006). All three variable regions of the TRIM5alpha B30.2 domain can contribute to the specificity of retrovirus restriction. *J. Virol.* 80, 8554-8565.
- Ohmine, S., Sakuma, R., Sakuma, T., Thatava, T., Takeuchi, H., and Ikeda, Y. (2011). The antiviral spectra of TRIM5alpha orthologues and human TRIM family proteins against lentiviral production. *PLoS One* 6, e16121.
- Onyango, C.O., Leligdowicz, A., Yokoyama, M., Sato, H., Song, H., Nakayama, E.E., Shioda, T., de Silva, T., Townend, J., Jaye, A., *et al.* (2010). HIV-2 capsids distinguish high and low virus load patients in a West African community cohort. *Vaccine* 28, B60-B67.

- Ortiz, M., Bleiber, G., Martinez, R., Kaessmann, H., and Telenti, A. (2006). Patterns of evolution of host proteins involved in retroviral pathogenesis. *Retrovirology* 3, 11.
- Ozato, K., Shin, D.M., Chang, T.H., and Morse, H.C. (2008). TRIM family proteins and their emerging roles in innate immunity. *Nat. Rev. Immunol.* 8, 849-860.
- Pacheco, B., Finzi, A., McGee-Estrada, K., and Sodroski, J. (2010). Species-specific inhibition of foamy viruses from South American monkeys by New World Monkey TRIM5 α proteins. *J. Virol.* 84, 4095-4099.
- Pekrun, K., Shibata, R., Igarashi, T., Reed, M., Sheppard, L., Patten, P.A., Stemmer, W.P.C., Martin, M.A., and Soong, N. (2002). Evolution of a Human Immunodeficiency Virus Type 1 Variant with Enhanced Replication in Pig-Tailed Macaque Cells by DNA Shuffling. *J. Virol.* 76, 2924-2935.
- Perez-Caballero, D., Soll, S.J., and Bieniasz, P.D. (2008). Evidence for Restriction of Ancient Primate Gammaretroviruses by APOBEC3 but Not TRIM5 α Proteins. *PLoS Pathog* 4, e1000181.
- Perron, M.J., Stremlau, M., Song, B., Ulm, W., Mulligan, R.C., and Sodroski, J. (2004). TRIM5 α mediates the postentry block to N-tropic murine leukemia viruses in human cells. *Proc. Natl. Acad. Sci. U.S.A.* 101, 11827-11832.
- Pertel, T., Hausmann, S., Morger, D., Zuger, S., Guerra, J., Lascano, J., Reinhard, C., Santoni, F.A., Uchil, P.D., Chatel, L., *et al.* (2011). TRIM5 is an innate immune sensor for the retrovirus capsid lattice. *Nature* 472, 361-365.
- Powell, R.D., Holland, P.J., Hollis, T., and Perrino, F.W. (2011). Aicardi-Goutieres syndrome gene and HIV-1 restriction factor SAMHD1 is a dGTP-regulated deoxynucleotide triphosphohydrolase. *J. Biol. Chem.* 286, 43596-43600.
- Price, A.J., Marzetta, F., Lammers, M., Ylinen, L.M., Schaller, T., Wilson, S.J., Towers, G.J., and James, L.C. (2009). Active site remodeling switches HIV specificity of antiretroviral TRIMCyp. *Nat. Struct. Mol. Biol.* 16, 1036-1042.
- Price, H., Lacap, P., Tuff, J., Wachihi, C., Kimani, J., Ball, T.B., Luo, M., and Plummer, F.A. (2010). A TRIM5 α exon 2 polymorphism is associated with protection from HIV-1 infection in the Pumwani sex worker cohort. *AIDS* 24, 1813-1821.
- Raum, R.L., Sterner, K.N., Noviello, C.M., Stewart, C., and Disotell, T.R. (2005). Catarrhine primate divergence dates estimated from complete mitochondrial genomes: concordance with fossil and nuclear DNA evidence. *J. Hum. Evol.* 48, 237-257.
- Rajsbaum, R., Stoye, J.P., and O'Garra, A. (2008). Type I interferon-dependent and -independent expression of tripartite motif proteins in immune cells. *Eur. J. Immunol.* 38, 619-630.
- Reed, S.E., Staley, E.M., Mayginnis, J.P., Pintel, D.J., and Tullis, G.E. (2006). Transfection of mammalian cells using linear polyethylenimine is a simple and effective means of producing recombinant adeno-associated virus vectors. *J. Virol. Methods* 138, 85-98.
- Regad, T., Saib, A., Lallemand-Breitenbach, V., Pandolfi, P.P., de The, H., and Chelbi-Alix, M.K. (2001). PML mediates the interferon-induced antiviral state against a complex retrovirus via its association with the viral transactivator. *EMBO J.* 20, 3495-3505.

- Reichelt, M., Wang, L., Sommer, M., Perrino, J., Nour, A.M., Sen, N., Baiker, A., Zerboni, L., and Arvin, A.M. (2011). Entrapment of viral capsids in nuclear PML cages is an intrinsic antiviral host defense against varicella-zoster virus. *PLoS Pathog.* 7, e1001266.
- Reymond, A., Meroni, G., Fantozzi, A., Merla, G., Cairo, S., Luzi, L., Riganelli, D., Zanaria, E., Messali, S., Cainarca, S., *et al.* (2001). The tripartite motif family identifies cell compartments. *EMBO J.* 20, 2140-2151.
- Ribeiro, I.P., Menezes, A.N., Moreira, M.A., Bonvicino, C.R., Seunanez, H.N., and Soares, M.A. (2005). Evolution of cyclophilin A and TRIMCyp retrotransposition in New World primates. *J. Virol.* 79, 14998-15003.
- Saito, A., Kono, K., Nomaguchi, M., Yasutomi, Y., Adachi, A., Shioda, T., Akari, H., and Nakayama, E.E. (2012). Geographical, genetic and functional diversity of antiretroviral host factor TRIMCyp in cynomolgus macaque (*Macaca fascicularis*). *J. Gen. Virol.* 93, 594-602.
- Saito, A., Nomaguchi, M., Iijima, S., Kuroishi, A., Yoshida, T., Lee, Y.J., Hayakawa, T., Kono, K., Nakayama, E.E., Shioda, T., *et al.* (2011). Improved capacity of a monkey-tropic HIV-1 derivative to replicate in cynomolgus monkeys with minimal modifications. *Microbes Infect.* 13, 58-64.
- Sakuma, R., Mael, A.A., and Ikeda, Y. (2007a). Alpha interferon enhances TRIM5alpha-mediated antiviral activities in human and rhesus monkey cells. *J. Virol.* 81, 10201-10206.
- Sakuma, R., Noser, J.A., Ohmine, S., and Ikeda, Y. (2007b). Rhesus monkey TRIM5alpha restricts HIV-1 production through rapid degradation of viral Gag polyproteins. *Nat. Med.* 13, 631-635.
- Sardiello, M., Cairo, S., Fontanella, B., Ballabio, A., and Meroni, G. (2008). Genomic analysis of the TRIM family reveals two groups of genes with distinct evolutionary properties. *BMC Evol. Biol.* 8, 225.
- Sauter, D., Schindler, M., Specht, A., Landford, W.N., Munch, J., Kim, K.A., Votteler, J., Schubert, U., Bibollet-Ruche, F., Keele, B.F., *et al.* (2009). Tetherin-driven adaptation of Vpu and Nef function and the evolution of pandemic and nonpandemic HIV-1 strains. *Cell. Host Microbe* 6, 409-421.
- Sawyer, S.L., Emerman, M., and Malik, H.S. (2007). Discordant evolution of the adjacent antiretroviral genes TRIM22 and TRIM5 in mammals. *PLoS Pathog.* 3, e197.
- Sawyer, S.L., Wu, L.I., Akey, J.M., Emerman, M., and Malik, H.S. (2006). High-frequency persistence of an impaired allele of the retroviral defense gene TRIM5alpha in humans. *Curr. Biol.* 16, 95-100.
- Sawyer, S.L., Wu, L.I., Emerman, M., and Malik, H.S. (2005). Positive selection of primate TRIM5alpha identifies a critical species-specific retroviral restriction domain. *Proc. Natl. Acad. Sci. U. S. A.* 102, 2832-2837.
- Sayah, D.M., and Luban, J. (2004). Selection for loss of Ref1 activity in human cells releases human immunodeficiency virus type 1 from cyclophilin A dependence during infection. *J. Virol.* 78, 12066-12070.
- Sayah, D.M., Sokolskaja, E., Berthoux, L., and Luban, J. (2004). Cyclophilin A retrotransposition into TRIM5 explains owl monkey resistance to HIV-1. *Nature* 430, 569-573.

- Schaller, T., Hue, S., and Towers, G.J. (2007a). An active TRIM5 protein in rabbits indicates a common antiviral ancestor for mammalian TRIM5 proteins. *J. Virol.* *81*, 11713-11721.
- Schaller, T., Ylinen, L.M., Webb, B.L., Singh, S., and Towers, G.J. (2007b). Fusion of cyclophilin A to Fv1 enables cyclosporine-sensitive restriction of human and feline immunodeficiency viruses. *J. Virol.* *81*, 10055-10063.
- Sebastian, S., and Luban, J. (2005). TRIM5alpha selectively binds a restriction-sensitive retroviral capsid. *Retrovirology* *2*, 40.
- Sewram, S., Singh, R., Kormuth, E., Werner, L., Mlisana, K., Karim, S.S.A., and CAPRISA Acute Infection Study Team. (2009). Human TRIM5 α Expression Levels and Reduced Susceptibility to HIV-1 Infection. *J. Infect. Dis.* *199*, 1657-1663.
- Sharp, P.M., and Hahn, B.H. (2011). Origins of HIV and the AIDS Pandemic. *Cold Spring Harb Perspect. Med.* *1*, a006841.
- Sheehy, A.M., Gaddis, N.C., Choi, J.D., and Malim, M.H. (2002). Isolation of a human gene that inhibits HIV-1 infection and is suppressed by the viral Vif protein. *Nature* *418*, 646-650.
- Shi, M., Deng, W., Bi, E., Mao, K., Ji, Y., Lin, G., Wu, X., Tao, Z., Li, Z., Cai, X., *et al.* (2008). TRIM30 alpha negatively regulates TLR-mediated NF-kappa B activation by targeting TAB2 and TAB3 for degradation. *Nat. Immunol.* *9*, 369-377.
- Si, Z., Vandegraaff, N., O'hUigin, C., Song, B., Yuan, W., Xu, C., Perron, M., Li, X., Marasco, W.A., Engelman, A., Dean, M., and Sodroski, J. (2006). Evolution of a cytoplasmic tripartite motif (TRIM) protein in cows that restricts retroviral infection. *Proc. Natl. Acad. Sci. U.S.A.* *103*, 7454-7459.
- Smith, D.G., McDonough, J.W., and George, D.A. (2007). Mitochondrial DNA variation within and among regional populations of longtail macaques (*Macaca fascicularis*) in relation to other species of the *fascicularis* group of macaques. *Am. J. Primatol.* *69*, 182-198.
- Sokolskaja, E., Berthouex, L., and Luban, J. (2006). Cyclophilin A and TRIM5alpha independently regulate human immunodeficiency virus type 1 infectivity in human cells. *J. Virol.* *80*, 2855-2862.
- Song, B., Gold, B., O'Huigin, C., Javanbakht, H., Li, X., Stremlau, M., Winkler, C., Dean, M., and Sodroski, J. (2005a). The B30.2(SPRY) domain of the retroviral restriction factor TRIM5alpha exhibits lineage-specific length and sequence variation in primates. *J. Virol.* *79*, 6111-6121.
- Song, B., Javanbakht, H., Perron, M., Park, D.H., Stremlau, M., and Sodroski, J. (2005b). Retrovirus restriction by TRIM5alpha variants from Old World and New World primates. *J. Virol.* *79*, 3930-3937.
- Song, H., Nakayama, E.E., Yokoyama, M., Sato, H., Levy, J.A., and Shioda, T. (2007). A single amino acid of the human immunodeficiency virus type 2 capsid affects its replication in the presence of cynomolgus monkey and human TRIM5alphas. *J. Virol.* *81*, 7280-7285.
- Speelman, E.C., Livingston-Rosanoff, D., Li, S.S., Vu, Q., Bui, J., Geraghty, D.E., Zhao, L.P., and McElrath, M.J. (2006). Genetic association of the antiviral restriction factor TRIM5alpha with human immunodeficiency virus type 1 infection. *J. Virol.* *80*, 2463-2471.
- Stevison, L.S., and Kohn, M.H. (2009). Divergence population genetic analysis of hybridization between rhesus and cynomolgus macaques. *Mol. Ecol.* *18*, 2457-2475.

- Strebel, K., Luban, J., and Jeang, K.T. (2009). Human cellular restriction factors that target HIV-1 replication. *BMC Med.* 7, 48.
- Street, S.L., Kyes, R.C., Grant, R., and Ferguson, B. (2007). Single nucleotide polymorphisms (SNPs) are highly conserved in rhesus (*Macaca mulatta*) and cynomolgus (*Macaca fascicularis*) macaques. *BMC Genomics* 8, 480.
- Stremlau, M., Owens, C.M., Perron, M.J., Kiessling, M., Autissier, P., and Sodroski, J. (2004). The cytoplasmic body component TRIM5alpha restricts HIV-1 infection in Old World monkeys. *Nature* 427, 848-853.
- Stremlau, M., Perron, M., Lee, M., Li, Y., Song, B., Javanbakht, H., Diaz-Griffero, F., Anderson, D.J., Sundquist, W.I., and Sodroski, J. (2006). Specific recognition and accelerated uncoating of retroviral capsids by the TRIM5alpha restriction factor. *Proc. Natl. Acad. Sci. U. S. A.* 103, 5514-5519.
- Stremlau, M., Perron, M., Welikala, S., and Sodroski, J. (2005). Species-specific variation in the B30.2(SPRY) domain of TRIM5alpha determines the potency of human immunodeficiency virus restriction. *J. Virol.* 79, 3139-3145.
- Stremlau, M., Song, B., Javanbakht, H., Perron, M., and Sodroski, J. (2006). Cyclophilin A: an auxiliary but not necessary cofactor for TRIM5alpha restriction of HIV-1. *Virology* 351, 112-120.
- Tajima, F. (1989). Statistical method for testing the neutral mutation hypothesis by DNA polymorphism. *Genetics* 123, 585-595.
- Tamura, K., Dudley, J., Nei, M., and Kumar, S. (2007). MEGA4: Molecular Evolutionary Genetics Analysis (MEGA) software version 4.0. *Mol. Biol. Evol.* 24, 1596-1599.
- Tamura, K., Peterson, D., Peterson, N., Stecher, G., Nei, M., and Kumar, S. (2011). MEGA5: molecular evolutionary genetics analysis using maximum likelihood, evolutionary distance, and maximum parsimony methods. *Mol. Biol. Evol.* 28, 2731-2739.
- Tareen, S.U., and Emerman, M. (2011). Human Trim5alpha has additional activities that are uncoupled from retroviral capsid recognition. *Virology* 409, 113-120.
- Tareen, S.U., Sawyer, S.L., Malik, H.S., and Emerman, M. (2009). An expanded clade of rodent Trim5 genes. *Virology* 385, 473-483.
- Taylor, R.T., Lubick, K.J., Robertson, S.J., Broughton, J.P., Bloom, M.E., Bresnahan, W.A., and Best, S.M. (2011). TRIM79alpha, an interferon-stimulated gene product, restricts tick-borne encephalitis virus replication by degrading the viral RNA polymerase. *Cell. Host Microbe* 10, 185-196.
- Thippeshappa, R., Polacino, P., Yu Kimata, M.T., Siwak, E.B., Anderson, D., Wang, W., Sherwood, L., Arora, R., Wen, M., Zhou, P., Hu, S., and Kimata, J.T. (2011). Vif Substitution Enables Persistent Infection of Pig-Tailed Macaques by Human Immunodeficiency Virus Type 1. *J. Virol.* 85, 3767-3779.
- Torimiro, J.N., Javanbakht, H., Diaz-Griffero, F., Kim, J., Carr, J.K., Carrington, M., Sawitzke, J., Burke, D.S., Wolfe, N.D., Dean, M., and Sodroski, J. (2009). A rare null allele potentially encoding a dominant-negative TRIM5alpha protein in Baka pygmies. *Virology* 391, 140-147.

- Tosi, A.J., Morales, J.C., and Melnick, D.J. (2003). Paternal, maternal, and biparental molecular markers provide unique windows onto the evolutionary history of macaque monkeys. *Evolution* 57, 1419-1435.
- Tosi, A.J., and Coke, C.S. (2007). Comparative phylogenetics offer new insights into the biogeographic history of *Macaca fascicularis* and the origin of the Mauritian macaques. *Mol. Phylogenet. Evol.* 42, 498-504.
- Towers, G.J. (2007). The control of viral infection by tripartite motif proteins and cyclophilin A. *Retrovirology* 4, 40.
- Towers, G., Bock, M., Martin, S., Takeuchi, Y., Stoye, J.P., and Danos, O. (2000). A conserved mechanism of retrovirus restriction in mammals. *Proc. Natl. Acad. Sci. U.S.A.* 97, 12295-12299.
- Turelli, P., Doucas, V., Craig, E., Mangeat, B., Klages, N., Evans, R., Kalpana, G., and Trono, D. (2001). Cytoplasmic recruitment of INI1 and PML on incoming HIV preintegration complexes: interference with early steps of viral replication. *Mol. Cell* 7, 1245-1254.
- Uchil, P.D., Quinlan, B.D., Chan, W.T., Luna, J.M., and Mothes, W. (2008). TRIM E3 ligases interfere with early and late stages of the retroviral life cycle. *PLoS Pathog.* 4, e16.
- van der Aa, L.M., Levraud, J.P., Yahmi, M., Lauret, E., Briolat, V., Herbomel, P., Benmansour, A., and Boudinot, P. (2009). A large new subset of TRIM genes highly diversified by duplication and positive selection in teleost fish. *BMC Biol.* 7, 7.
- van Manen, D., Rits, M.A., Beugeling, C., van Dort, K., Schuitemaker, H., and Kootstra, N.A. (2008). The effect of Trim5 polymorphisms on the clinical course of HIV-1 infection. *PLoS Pathog.* 4, e18.
- Virgen, C.A., Kratovac, Z., Bieniasz, P.D., and Hatziioannou, T. (2008). Independent genesis of chimeric TRIM5-cyclophilin proteins in two primate species. *Proc. Natl. Acad. Sci. U. S. A.* 105, 3563-3568.
- Wilson, S.J., Webb, B.L., Maplanka, C., Newman, R.M., Verschoor, E.J., Heeney, J.L., and Towers, G.J. (2008a). Rhesus macaque TRIM5 alleles have divergent antiretroviral specificities. *J. Virol.* 82, 7243-7247.
- Wilson, S.J., Webb, B.L., Ylinen, L.M., Verschoor, E., Heeney, J.L., and Towers, G.J. (2008b). Independent evolution of an antiviral TRIMCyp in rhesus macaques. *Proc. Natl. Acad. Sci. U. S. A.* 105, 3557-3562.
- Wiseman, R.W., Wojcechowskyj, J.A., Greene, J.M., Blasky, A.J., Gojon, T., Soma, T., Friedrich, T.C., O'Connor, S.L., and O'Connor, D.H. (2007). Simian immunodeficiency virus SIVmac239 infection of major histocompatibility complex-identical cynomolgus macaques from Mauritius. *J. Virol.* 81, 349-361.
- Wolf, D., and Goff, S.P. (2007). TRIM28 mediates primer binding site-targeted silencing of murine leukemia virus in embryonic cells. *Cell* 131, 46-57.
- Wolf, D., Hug, K., and Goff, S.P. (2008). TRIM28 mediates primer binding site-targeted silencing of Lys1,2 tRNA-utilizing retroviruses in embryonic cells. *Proc. Natl. Acad. Sci. U.S.A.* 105, 12521-12526.
- Wu, X., Anderson, J.L., Campbell, E.M., Joseph, A.M., and Hope, T.J. (2006). Proteasome inhibitors uncouple rhesus TRIM5 α restriction of HIV-1 reverse transcription and infection. *103*, 7465-7470.

- Yamauchi, K., Wada, K., Tanji, K., Tanaka, M., and Kamitani, T. (2008). Ubiquitination of E3 ubiquitin ligase TRIM5 alpha and its potential role. *FEBS J.* 275, 1540-1555.
- Yang, S.J., Lopez, L.A., Hauser, H., Exline, C.M., Haworth, K.G., and Cannon, P.M. (2010). Anti-tetherin activities in Vpu-expressing primate lentiviruses. *Retrovirology* 7, 13.
- Yap, M.W., Dodding, M.P., and Stoye, J.P. (2006). Trim-cyclophilin A fusion proteins can restrict human immunodeficiency virus type 1 infection at two distinct phases in the viral life cycle. *J. Virol.* 80, 4061-4067.
- Yap, M.W., Lindemann, D., Stanke, N., Reh, J., Westphal, D., Hanenberg, H., Ohkura, S., and Stoye, J.P. (2008). Restriction of foamy viruses by primate Trim5alpha. *J. Virol.* 82, 5429-5439.
- Yap, M.W., Mortuza, G.B., Taylor, I.A., and Stoye, J.P. (2007). The design of artificial retroviral restriction factors. *Virology* 365, 302-314.
- Yap, M.W., Nisole, S., Lynch, C., and Stoye, J.P. (2004). Trim5alpha protein restricts both HIV-1 and murine leukemia virus. *Proc. Natl. Acad. Sci. U. S. A.* 101, 10786-10791.
- Yap, M.W., Nisole, S., and Stoye, J.P. (2005). A single amino acid change in the SPRY domain of human Trim5alpha leads to HIV-1 restriction. *Curr. Biol.* 15, 73-78.
- Yeh, W.W., Rao, S.S., Lim, S., Zhang, J., Hraber, P.T., Brassard, L.M., Luedemann, C., Todd, J.P., Dodson, A., Shen, L., *et al.* (2011). The TRIM5 Gene Modulates Penile Mucosal Acquisition of Simian Immunodeficiency Virus in Rhesus Monkeys. *J. Virol.* 85, 10389-10398.
- Ylinen, L.M., Keckesova, Z., Webb, B.L., Gifford, R.J., Smith, T.P., and Towers, G.J. (2006). Isolation of an active Lv1 gene from cattle indicates that tripartite motif protein-mediated innate immunity to retroviral infection is widespread among mammals. *J. Virol.* 80, 7332-7338.
- Ylinen, L.M.J., Price, A.J., Rasaiyaah, J., Hué, S., Rose, N.J., Marzetta, F., James, L.C., and Towers, G.J. (2010). Conformational Adaptation of Asian Macaque TRIMCyp Directs Lineage Specific Antiviral Activity. *PLoS Pathog* 6, e1001062.
- Yu, S., Gao, B., Duan, Z., Xu, W., and Xiong, S. (2011). Identification of tripartite motif-containing 22 (TRIM22) as a novel NF- κ B activator. *Biochem. Biophys. Res. Commun.* 410, 247-251.
- Zhang, F., Perez-Caballero, D., Hatzioannou, T., and Bieniasz, P.D. (2008). No effect of endogenous TRIM5alpha on HIV-1 production. *Nat. Med.* 14, 235-6; author reply 236-8.
- Zhang, X., Kondo, M., Chen, J., Miyoshi, H., Suzuki, H., Ohashi, T., and Shida, H. (2010). Inhibitory effect of human TRIM5 α on HIV-1 production. *Microb. Infect.* 12, 768-777.
- Zhang, Z., Harrison, P.M., Liu, Y., and Gerstein, M. (2003). Millions of Years of Evolution Preserved: A Comprehensive Catalog of the Processed Pseudogenes in the Human Genome. *Genome Res.* 13, 2541-2558.
- Zhao, G., Ke, D., Vu, T., Ahn, J., Shah, V.B., Yang, R., Aiken, C., Charlton, L.M., Gronenborn, A.M., and Zhang, P. (2011). Rhesus TRIM5alpha disrupts the HIV-1 capsid at the inter-hexamer interfaces. *PLoS Pathog.* 7, e1002009.
- Zheng, Y.H., and Peterlin, B.M. (2005). Intracellular immunity to HIV-1: newly defined retroviral battles inside infected cells. *Retrovirology* 2, 25.

Ziegler, T., Abegg, C., Meijaard, E., Perwitasari-Farajallah, D., Walter, L., Hodges, J.K., and Roos, C. (2007). Molecular phylogeny and evolutionary history of Southeast Asian macaques forming the *M. silenus* group. *Mol. Phylogenet. Evol.* 42, 807-816.

CURRICULUM VITAE

Education

Doctor of Philosophy in Microbiology

University of Washington (2012)

Dissertation: The function and diversity of the antiretroviral restriction factors TRIM5 α and TRIMCyp in Old World primates

Bachelor of Arts in Biology, Summa Cum Laude

Carleton College (2004)

Senior Thesis: Molecular mechanisms of human LINE-1 retrotransposition.

Research Experience

University of Washington, Seattle, Washington (2008-2012)

Evolution and function of TRIM5 α and TRIMCyp in macaques (Mentor, **Shiu-Lok Hu**)

I showed that the variant restriction factor TRIMCyp evolved in the common ancestor of the Asian macaques. I also described the genetic variability of TRIMCyp in *Macaca fascicularis*, a species commonly used as an AIDS model. I defined several polymorphisms in *M. fascicularis* TRIMCyp that affect antiviral function.

University of Minnesota, Minneapolis, Minnesota (2006-2007)

Oral transmission of HIV-1 (Mentor, **Mark C. Herzberg**)

I described the kinetics of HIV-1 inactivation by saliva at various dilutions. I also examined host factors expressed in oral epithelial cells that could impact transcytosis or infection of this cell type by HIV-1.

University of Minnesota, Minneapolis, Minnesota (2004-2006)

Innate immune defense in oral epithelial cells (Mentor, **Karen F. Ross**)

I examined the effects of calprotectin (S100A8/A9) expression in oral epithelial cells on infection by pathogens such as *Candida albicans* and *Listeria monocytogenes*.

Awards and Honors

Early Investigator Award, Annual Symposium on Nonhuman Primate Models for AIDS, 2011.

Honorable Mention, NSF Graduate Research Fellowship Program, 2009

Phi Beta Kappa, 2004

Carleton College Dean's List, 2001-2003

Service

Student member, Department of Microbiology graduate admissions committee, 2010

Volunteer judge, Northwest Association for Biomedical Research "Biomedical Breakthroughs and My Life" essay contest for 7th-8th grade students, 2008-2012

Memberships

American Society for Microbiology, 2007-present

Teaching

University of Washington, Department of Microbiology

Guest lecture: Fundamentals of Cloning, MICROM 431 (Recombinant DNA Techniques), 2012

Guest lecture: Southern Blots, MICROM 431 (Recombinant DNA Techniques), 2012

Teaching assistant, MICROM 411 (Gene Action Laboratory), 2009

Teaching assistant, MICROM 302 (General Microbiology Laboratory), 2008

Carleton College, 2004

Teaching assistant, Molecular Biology

Publications

E.A. Dietrich, K.H. Gebhard, C.E. Fasching, R.A. Giacaman, J.C. Kappes, K.F. Ross, and M.C. Herzberg. 2012. HIV type 1 escapes inactivation by saliva via rapid escape into oral epithelial cells. *AIDS Research and Human Retroviruses*, in press.
<http://dx.doi.org/10.1089/AID.2011.0069>.

E.A. Dietrich, G. Brennan, B. Ferguson, R.W. Wiseman, D. O'Connor, and S.L. Hu. 2011. Variable prevalence and functional diversity of the antiretroviral restriction factor TRIMCyp in *Macaca fascicularis*. *Journal of Virology* **85**:9956-9963.
<http://jvi.asm.org/content/85/19/9956>.

E.A. Dietrich, L. Jones-Engel, and S.L. Hu. 2010. Evolution of the antiretroviral restriction factor TRIMCyp in Old World primates. *PLoS One* **5**:e14019.
<http://dx.doi.org/10.1371/journal.pone.0014019>.

A.A. Zaia, K.J. Sappington, K. Nisapakultorn, W.J. Chazin, **E.A. Dietrich**, K.F. Ross, and M.C. Herzberg. 2009. Subversion of antimicrobial calprotectin (S100A8/S100A9 complex) in the cytoplasm of TR146 epithelial cells after invasion by *Listeria monocytogenes*. *Mucosal Immunology* **2**:43-53. <http://dx.doi.org/10.1038/mi.2008.63>.

R.A. Giacaman, A.C. Asrani, K.H. Gebhard, **E.A. Dietrich**, A. Vacharaksa, K.F. Ross, and M.C. Herzberg. 2008. *Porphyromonas gingivalis* induces CCR5-dependent transfer of infectious HIV-1 from oral keratinocytes to permissive cells. *Retrovirology* **5**:29.
<http://dx.doi.org/10.1186/1742-4690-5-29>.

Presentations

E.A. Dietrich, G. Brennan, B. Ferguson, R.W. Wiseman, D. O'Connor, and S.L. Hu. Functional diversity of the retroviral restriction factor TRIMCyp in *Macaca fascicularis*. Oral Presentation. Annual Symposium on Nonhuman Primate Models for AIDS, October 25-28, 2011.

E.A. Dietrich, L. Jones-Engel, and S.L. Hu. Evolution of the Antiretroviral Restriction Factor TRIMCyp in Old World Primates. Poster. Cold Spring Harbor Meeting on Retroviruses, May 24-29, 2010.

E.A. Dietrich, K.H. Gebhard, C.E. Fasching, K.F. Ross, and M.C. Herzberg. Survival of HIV-1 in whole saliva. Poster. American Society for Microbiology General Meeting, May 21-25, 2007.