

Dynamic Balance_school as living system

Nile vanWestrienen

A thesis
submitted in the partial fulfillment of the
requirements for the degree of

Master of Architecture

University of Washington
2016

Committee:
Robert Peña, Chair
Judith Heerwagen

Program Authorized to Offer Degree:
Architecture

© Copyright 2016
Nile vanWestrienen

University of Washington

Abstract

Dynamic Balance_school as living system

Nile vanWestrienen

Chair of the Supervisory Committee:

Robert Peña

Architecture

Currently, the scale and speed of human progress is disproportionate to live sustainably within the environment. This type of progress has forced us to choose between the continuation of human excess or the balance and rekindling between the human and natural world. Through an exploration into the ways that our environment affects our perspective and understanding, as well as the nature of children and their developmental needs, this thesis emphasizes the important role children play in reconnecting us to nature.

Architecturally, this thesis explores a methodology to elementary school design. These places for learning are supposed to provide the foundation to our children's understanding of the world. Included in the methodology is a systems-based approach to architectural design, a pedagogy in experiential education and Ecoliteracy, and an alignment to fit the culture of each community. With this framework for design, our future generations will be able to reclaim their connection to nature.

For my wife **Elise**
& my son **Rye**

Acknowledgments

This work is only possible through a culmination of experiences shared with:

Family_____for the stories and insights from a piece of their life to mine

Friends_____for listening to me ramble and change my mind over and over

Teachers_____Rob Peña, Judith Heerwagen, and Anne Taylor for encouragement and inspiration

Strangers_____for being a part of the world we all share

Nature_____for wisdom, patience and continual feedback

CONTENTS

<i>PREFACE</i>	xiv
<i>INTRODUCTION</i>	16
<i>THE PROBLEM</i>	18
<i>Invisible Structures</i>	20
<i>Visible Structures</i>	27
<i>Education</i>	30
<i>THE METHOD</i>	34
<i>Children</i>	38
<i>Experiential Education</i>	40
<i>Ecoliteracy</i>	44
<i>Permaculture</i>	47
<i>Theory Grounded</i>	56
<i>PLACE</i>	62
<i>Community and Culture</i>	64
<i>Climate</i>	72
<i>Ecology</i>	76
<i>Site</i>	80
<i>Concept</i>	90
<i>Design</i>	96
<i>CONCLUSION</i>	128



List of Figures

all images created by author unless otherwise noted

1. my son exploring the world
2. humans current vs needed relationship with nature
3. Corrales Elementary site photos
4. influences from invisible structures contained within society
5. community, education, and environment all affect our values
6. balancing today's values with tomorrow's possibilities
7. timeline of historical events that have affected our education systems in the U.S.
8. Corrales Elementary site photo
9. my son exploring the environment as an expression of biophilia
10. my son exploring the environment as an expression of biophilia
11. my son exploring the environment as an expression of biophilia
12. Reggio Emilia, Italy
source: <https://commons.wikimedia.org> (Paolo Picciati)
13. Corrales, NM, acequia farming as expressioin of place
14. Moab, Utah, rocks as an expression of place
15. Permaculture wheel principles
source: <https://permacultureprinciples.com/principles/> (David Holmgren)
16. Permaculture wheel principles and ethics
17. Academy for Global Citizenship: Studio Gang
source: <http://studiogang.com/project/academy-for-global-citizenship>
18. IslandWood: Mithun
source: <http://mithun.com/project/islandwood/>
19. Bullock's Permaculture Homestead
source: <http://www.permacultureportal.com/>
20. Academy for Global Citizenship sustainable systems
source: <http://studiogang.com/project/academy-for-global-citizenship21>.
21. living machine and sustainable systems at IslandWood
source: <http://mithun.com/project/islandwood/>
22. kids exploring at Bullock's Permaculture Homestead
source: <http://www.permacultureportal.com/>
23. learning Permaculture design
source: <http://www.permacultureportal.com/>
24. Academy for Global Citizenship entrance
source: <http://studiogang.com/project/academy-for-global-citizenship>
25. kids learning in treehouse
source: <http://mithun.com/project/islandwood/>
26. balancing systems in permaculture design
source: <http://www.permacultureportal.com/>
27. image of Corrales and map of New Mexico
28. pithouse section
source: *Mary P. Davis* "Corrales, New Mexico"
29. map of acequias in Corrales, NM
source: *Mary P. Davis* "Corrales, New Mexico"
30. watercolor of traditional farming methods in Corrales, NM
31. aerial photograph of the division of land in Corrales into long narrow strips
source: *Mary P. Davis* "Corrales, New Mexico"
32. map of Corrales, Albuquerque, and Rio Rancho
33. holistic approach to education
34. photograph of one of the original schools in Corrales, NM
source: *Mary P. Davis* "Corrales, New Mexico"
35. photograph of one of the original schools in Corrales, NM
source: *Mary P. Davis* "Corrales, New Mexico"
36. photograph of school built in 1925, Corrales, NM
source: *Mary P. Davis* "Corrales, New Mexico"
37. photograph of Wagner's Farm in Corrales, NM
38. photograph of harvest festival in Corrales, NM
39. climate data
40. diurnal averages
41. Sun diagram of Corrales, NM
42. wind diagram of Corrales, NM
43. vernacular building types of New Mexico
44. process of adobe making
45. historic dominant vegetation vs current dominant vegetation in NM
source: blm.gov
46. photograph of flora and fauna of Corrales Elementary
47. photograph of Rio Grande and bosque
48. photograph of vegetation left to grow wild
49. map of Corrales, NM with site highlighted
50. photographs of Corrales Elementary and surrounding site
51. aerial view of Corrales Elementary
52. photograph of myself as a student at Corrales Elementary
53. photograph of my mom working as counselor at Corrales Elementary
54. photograph of my wife working as 4th grade teacher at Corrales Elementary
55. photograph of my students as I was their educational assistant at Corrales Elementary
56. photograph of Corrales Elementary signage
57. photographs of the existing site of Corrales Elementary
58. performance evaluation of Corrales Elementary
source: U.S. Department of Education
59. aerial view of Corrales Elementary with site transparency
60. aerial view of Corrales Elementary showing site planning concept
61. development of a plant
62. development of a plant related to grade level

63. conceptual approach to site plan
64. vernacular building types related to student grade levels
65. site plan of re-designed Corrales Elementary
66. plaza / farmer's market
67. pea-patches
68. community learning
69. sundial play space
70. basic building block
71. basic building block applied to classrooms
72. courtyard scheme houses shared program
73. section showing program including teacher's room, entry, greenhouse, and cooking
74. basic building block + additional story for program and interior micro-climate
75. plan of root's environment
76. section showing curriculum of making soil
77. basic building block + pit house rooted into the soil
78. section through root's environment
79. perspective of root's environment
80. plan of stem's environment
81. section showing curriculum of harnessing energy
82. basic building block + pueblo lifted to the sky
83. section through stem's environment
84. perspective of stem's environment
85. plan of fruit's environment
86. section showing curriculum of systems development
87. basic building block + portal bringing nature inside
88. section through fruit's environment
89. perspective of fruit's environment
90. photograph entering the Village of Corrales

PREFACE

Dynamic Balance is a pattern found within nature expressing the relationships and responses we have to our environment. The Center for Ecoliteracy describes dynamic balance as “Ecological communities act(ing) as feedback loops, so that the community maintains a relatively steady state that also has continual fluctuations. This dynamic balance provides resiliency in the face of ecosystem change” (Stone). In nature, this balance is created by the living and dying of species due to opportunity and environmental constraints. Nature has evolved this way since the beginning of life. Humans, on the other hand, have developed and designed ways to ignore many of nature’s patterns and processes. In our ignorance, we have created a modern life requiring a pace that is outpacing our ability to adapt to these changes and nature’s capacity to evolve and adapt as well.

What sets us apart from other species are our ethics. The community at large understands that everyone should have equal opportunity and access to basic human needs like food, water and shelter. If this is the standard of humanity, then we must live by this standard. Inherent in this ethical standard is the protection of the earth and all of its ecosystems. Without a healthy environment, many will be deprived of both opportunity and basic human needs, and therefore will be less than equal.

We live in a time unlike any other. We must seek balance both in our personal lives and with the environment that sustains us. The time is passed for thinking only of ourselves. A growing proportion of humans are living not only in excess of their own needs, but beyond the carrying capacity of the planet. To have lived during this short time period of abundant growth is like winning the lottery and yet most of us cannot see this in our day to day lives. But with the spread of information through technology the scope of our impacts are becoming clear and we can no longer deny the extent of our destruction. While we are making some progress on modifying our destructive habits, real progress must address the root causes. We drive hybrid cars and put solar panels on our buildings, but we live, work and learn in buildings that are mostly unsuited to their climates, using far more energy than necessary for heating, cooling and lighting. Unlike cars, our buildings last a long time, and exert their impacts on the climate

for decades. Our society is built upon structures, ideas and regulations that no longer meet the imperatives of our age.

We are in an environmental crisis, and society is polarized in its response to this crisis. It is necessary to re-imagine our story and our way of living, and to identify our common ground of interests and needs in order to design solutions that allow us to live lives better suited to both our nature and mother nature; designs that nurture and sustain the things that keep us living and the things that are the source of beauty and happiness.

Too few of our amazing ideas and expectations for the future come to fruition within the context and constraints of modern society. We invest too little on changes today that will help us in the future. This difference between our present and future selves is the single greatest shift in our perception that needs to occur. If we ignore the feedback that our environment is giving us and fail to live within ethical boundaries for a wanted future, we are gambling away our future.

I am encouraging a rekindling of the connection between humans and nature so that we and our children may have a world that is full of life, connections, sunlight, water, and a bounty of smiles.

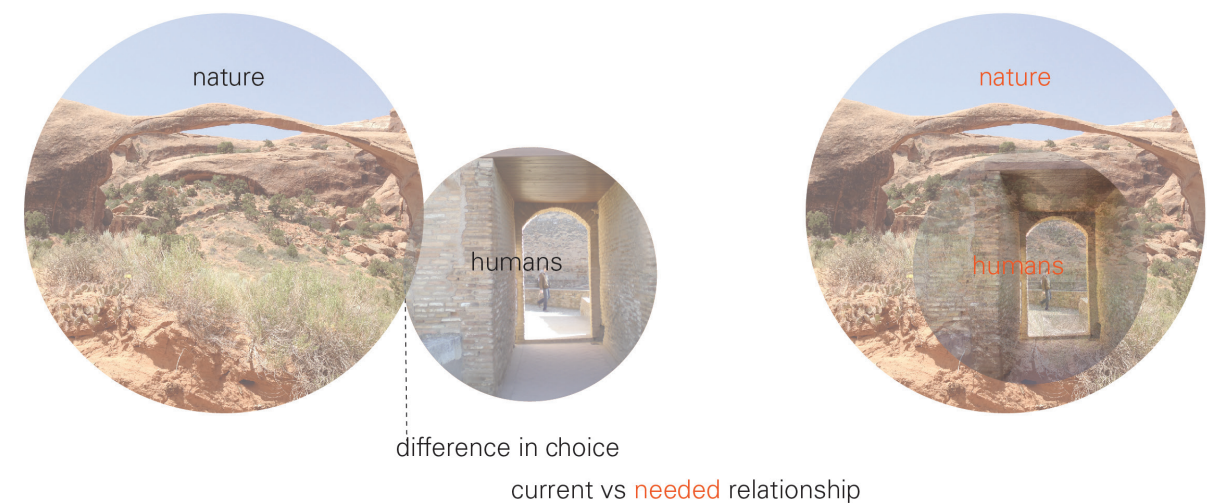

INTRODUCTION

The truth is that many things on which our future health and prosperity depend are in dire jeopardy: climate stability, the resilience and productivity of natural systems, the beauty of the natural world, and biological diversity. It is worth noting that this is not the work of ignorant people. Rather, it is largely the results of work by people with BAs, BSs, LLBs, MBAs, and PhDs.

-David W. Orr

The source of our sustenance and our good lives is slipping away. The environment, and all of its ecosystems, is in a rapid rate of deterioration. Much of this environmental impact has been caused by humans since the beginning of the industrial revolution. What has been generated from this revolution is an imbalance between the natural environment and the human environment. This imbalance has disconnected humans from the natural world, a kinship that we have shared for many millennium and are very close to severing. Wendell Berry points to the challenge implicit in this balance:

Humans, like all other creatures, must make a difference; otherwise, they cannot live. But unlike other creatures, humans must make a choice as to the kind and scale of the difference they make. If they choose to make too small a difference, they diminish their humanity. If they choose to make too great a difference, they diminish nature, and narrow their subsequent choices; ultimately, they diminish or destroy themselves. Nature, then, is not only our source but also our limit and measure (7-8, Berry).

Currently, the scale and speed of human progress is disproportionate to live sustainably within the environment. This type of progress has forced us to choose between the continuation of human excess or the balance and rekindling between the human and natural world.

This thesis begins by focusing on three factors or **problems** contained within society of the United States. Each of these factors affect people's perspective and understanding of the world. They are **invisible and visible structures** containing: **values**, the things that we find important in life, the **built environment**, the human hand that designs and uses tools to impress upon nature, and **education**, the ideas and experiences that we find important to pass on to future generations. After exploring how these factors create a physical and emotional place that influences the choices we make, the thesis will focus on the nature of children and the important role they play in reconnecting us to the natural world.

This thesis explores a **methodology** to designing elementary schools. These places for learning are supposed to provide the foundation to our children's understanding of the world. However, the majority of public schools provide a learning environment and teach to a system that is aimed at preparing them to compete in an industrial economy. While this system may be successful at producing future workers, it is a disaster at providing a place and pedagogy that will inspire people to be holistic learners and stewards of nature.

The fundamental question that this thesis addresses is: Can designing buildings as an armature for nature create an architectural environment that fosters lifelong learners and nurture community and ecological mindfulness? This thesis proposes a systems based approach to **architectural design** of elementary schools, that together with a pedagogy that has a strong foundation in **Ecoliteracy** and enriched to fit the goals and culture of each **community**, will help our future generations reclaim their connection to **nature**.

Lastly, this thesis argues for a human role in nature. Instead of viewing nature solely as a resource, it is imperative that people become stewards of the land, re-learning our deep connection that we once shared. Our future is only as good as the next generation conceives, and therefore, this is a time to **re-imagine** the **context** and **content** we are sharing with our youth. With an appropriate design, and children's innate curiosity and wonder, we might just be able to save the source of our sustenance and good lives.

THE PROBLEM

If the human economy is to be fitted into the natural economy in such a way that both may thrive, the human economy must be built to proper scale. It is possible to talk at great length about the difference between proper and improper scale. It may be enough to say here that the difference is suggested by the difference between amplified and unamplified music in the countryside, or the difference between the sound of a motorboat and the sound of oarlocks. A proper human sound, we may say, is one that allows other sounds to be heard. A properly scaled human economy or technology allows a diversity of other creatures to thrive.

'The proper scale,' a friend wrote to me, 'confers freedom and simplicity...and doubtless leads to long life and health.' I think that is also confers joy. The renewal of our partnership with nature, the rejoining of our works to their proper places in the natural order, reshaped to their proper scale, implies the re-enjoyment both of nature and of human domesticity. Though our task will be difficult, we will greatly mistake its nature if we see it as grim, or if we suppose that it must always be necessary to suffer at work in order to enjoy ourselves in places specializing in 'recreation.'

Once we grant the possibility of a proper human scale, we see that we have made a radical change in assumptions and values. We realize that we are, less interested in technological 'breakthroughs' than in technological elegance. Of a new tool or method we will no longer ask: Is it fast? Is it powerful? Is it a labor saver? How many workers will it replace? We will ask instead: Can we (and our children) afford it? Is it fitting to our real needs? Is it becoming to us? Is it unhealthy or ugly? And though we may keep a certain interest in innovation and in what we may become, we will renew our interest in what we have been, realizing that conservationists must necessarily conserve both inheritances, the natural and the cultural.

-Wendell Berry



Invisible Structures

Invisible structures are parts of a system that aren't usually tangible, and they are required to have a fully functioning and healthy system. Our current system that involves these structures has been evolving and adapting for millennium. Some of them have been passed down through culture, others have been adopted and others have become established through financial or other external pressures. One of the strongest of these structures are our values, which often permeate into the choices we make and affect our understanding of the world. Furthermore, values are so ingrained into our ways of modern life that they often seem more like truths than choices. Other examples of invisible structures that are also affected by values, but not limited to, include trust, ethics, time, technology, building and land use codes, finances, and social systems. These parts of a system often go unnoticed and unchallenged until they break. In order to improve upon these structures so that we may have a healthy system, we must first notice them and second, decide how to appropriately act on them before their breaking point. While this method seems simple enough, the problem is we either notice and don't act or act without understanding. Both the recognition and action require a broad understanding of our connection to place and therefore our limits.

background

Jean-Jacques Rousseau believed that "Man was born free, and is everywhere in chains." His theory is that we are all born in the state of nature as neither inherently good nor bad. It is when we enter into society that we are transformed and corrupted. To help create a society that has all of the benefits, but with minimal corruption, a *common good* is decided on by the will of the collective society. For this common good to work properly, the citizens would have to participate and give up some of their self interest for the betterment of the whole. These ideas had a profound impact on democracy and on the Constitution of the United States. Rousseau painted a picture of what a community or society could achieve, but it is up to us to decide what this common good is, it is up to us to participate to make it come to fruition, and it is up to

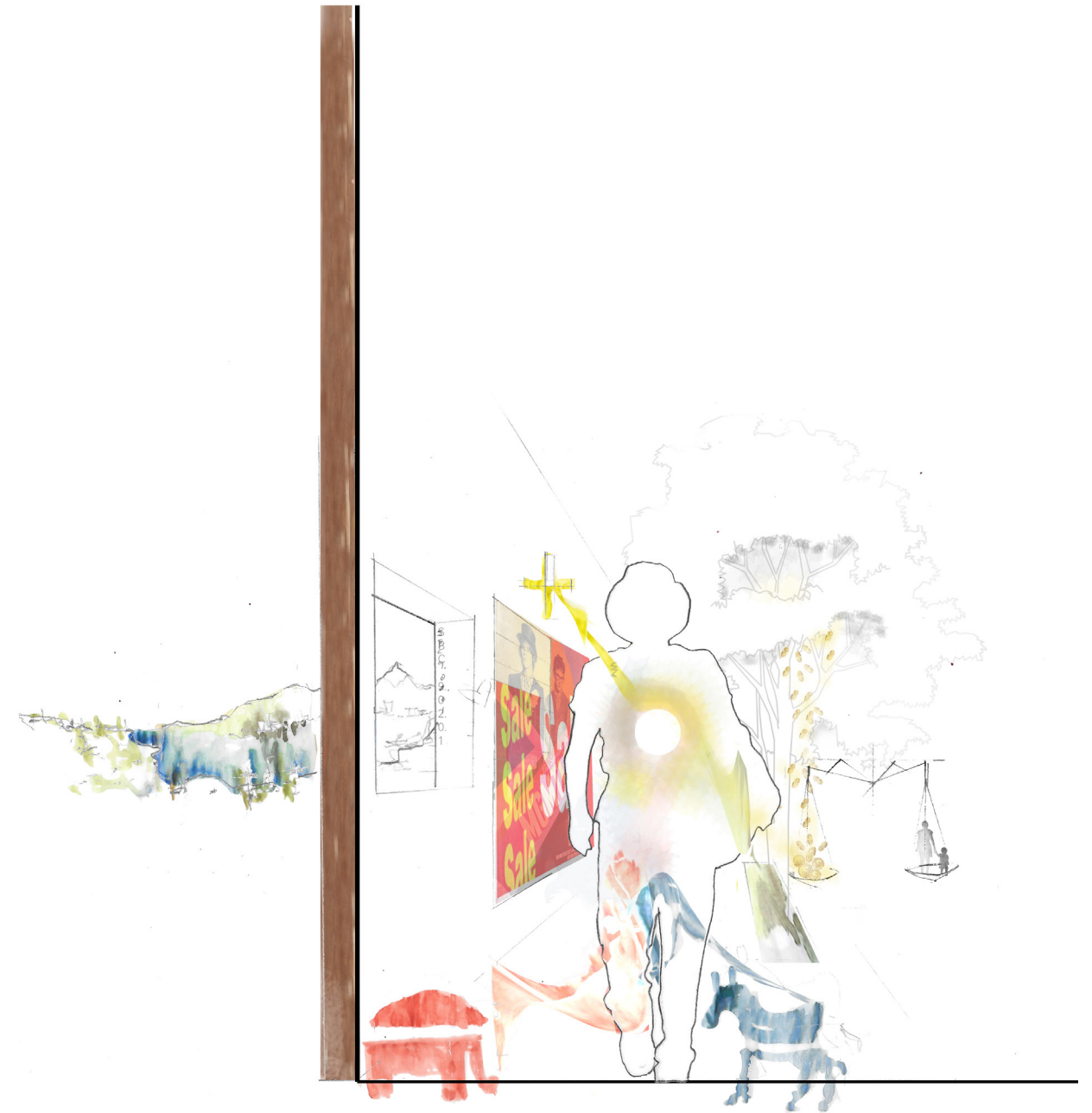

us to be content in our decision to enter into this social contract, and if we aren't? We need to change it.

What is the *common good*? If asked today compared to Rousseau's time, the answer may be very different as it is a question dependent upon time and place. What may be good for one town or one country may be very different in another town or another country, or simply another time. It would be hard to deny, however, that the health of the environment that supports us from and sustains us with nature is not a common good no matter the time or place. We are unable to separate ourselves from it and are therefore a part of it. Once we *value* this simple truth, creating a society made up of individuals that will be stewards of the environment is much more likely. In his book *Design for Ecological Democracy*, Randolph T. Hester speaks about the importance of bringing ecology into our democracy for a sustainable future:

Democracy bestows freedom—the dream of all who do not have it. Freedom can fuel personal fulfillment and, if unchecked, alienation, selfishness, and irresponsibility. Ecology explains our interconnected roles to even the lowliest creatures and makes us think comprehensively and outside narrow confines. In so doing, ecology creates responsible freedom. In a democracy, ecology is the constituency for the future. Ecology provides 'the rightly understood' in the political phrase 'self-interest rightly understood.' It forges the basis for civil society to address a shared public good among fractured interests (6-7).

Making matters difficult on the individual today are the values inherent in a capitalistic and technology driven society where competition, standardization, affluence, and many other values are deeply ingrained in us from an early age. This society and the values ingrained within it are products of the industrial revolution (Hester, 7).

values ■

Jean Jacques Rousseau, Loris Malaguzzi, Richard Louv, Michael Stone, Fritjof Capra, Edward O. Wilson, Anne Taylor, among others, speak to the idea that people, and especially children, have an innate connection to the natural world. This connection is gradually becoming lost in modern society. To further this claim, Richard Louv points out that "In Israel, researchers revealed that nearly all adults surveyed indicated that natural outdoor areas were the most significant environments of their childhood, while less than half of children ages eight to eleven

shared that view" (33). At the root of the cause are values that distract us from the need to be connected to nature.

The Industrial Revolution was rooted in values that are still present today. Being invisible structures, these values are not easy to change without a shift in perspective. The most prominent values in American society according to Randolph Hester are: mobility, affluence, standardization, technology, and specialization. These values free us from: place, relying on community, local identity, environmental processes, and comprehensive thinking (Hester, 17).

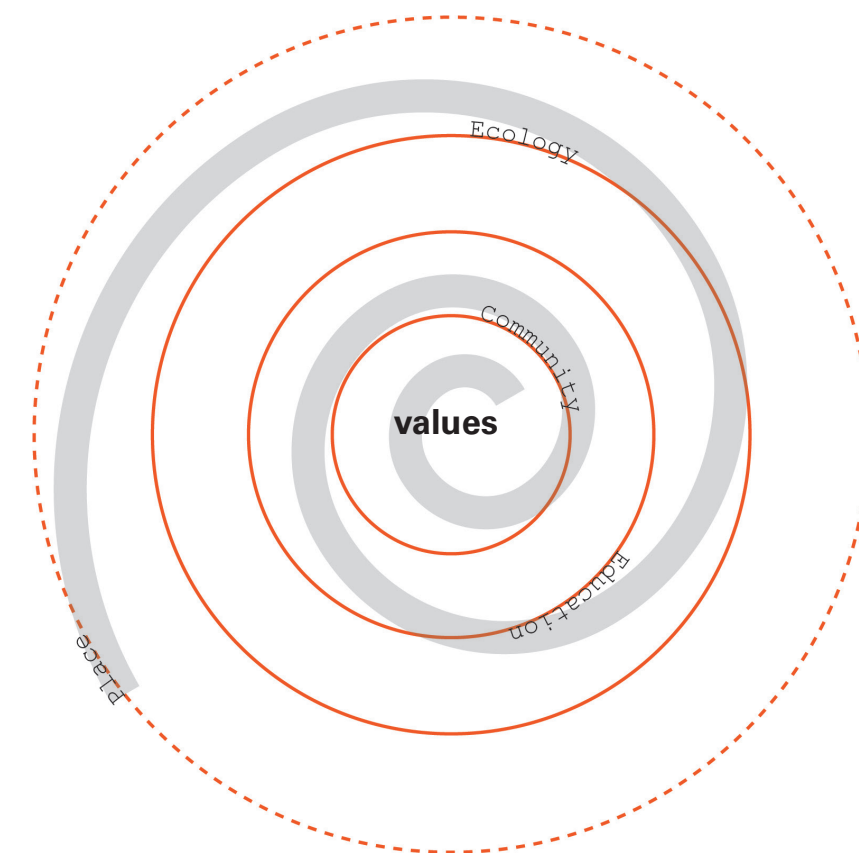

The freedom prompted by these values creates short-term single minded solutions to long-term systemic problems. This concern may not have been perceived as a problem when we thought the world was a vast expanse of resources. However, we know this is no longer the case. The values inherited from the Industrial Revolution have created dependency on large scale standardized solutions. These solutions, however, are only conceivable through the use of technology.

Technology has created a perceived increase in the speed of time, relative to what I will call natural time. Such examples of natural time include the time of the seasons, the growth of food, and the waxing and waning of the moon. With the advancement in technology, we no longer are strictly inhibited by the natural cycles. The downside to this ability is that we are still human, still a part of nature and we don't have the capacity to understand and reflect on the systemic impacts that this power brings. This cycle inevitably leads us to a role where we are dependent not upon each other, but upon the few people who understand technology which requires training and studies of several years. After all of this effort to sustain a technology driven society, we gain more luxuries, but at what cost?

The values inherent in today's society do not account for a balanced relationship between humans and the rest of the natural world. They are values that are inherently out of proportion and out of rhythm to the natural world. These values of mobility, affluence, standardization, technology, and specialization, permeate throughout our landscapes including the built environment. The values which are invisible structures turn into visible, tangible objects that still contain as much, if not more, meaning as they do in their invisible form.

An overlapping term, 'hidden curriculum,' coined by Brian Jackson in the 1960s, points to the fact that schools transmit not just 'knowledge' but also norms and values (such as respect, manners, fair play, and other traits needed to maintain a civil society). Sometimes hidden curriculum is intentional: in CEL terms, changing the context from the four walls of the classroom to include the culture and the community of the school, experiences in the garden, faculty talking to one another respectfully, or the use of a tablecloth in the dining room at The Edible Schoolyard are all hidden curriculum. Sometimes the hidden curriculum's lessons are not intentional, but reveal unspoken, and often unconscious, values: the soda machine in the hallway outside the classroom where nutrition is being taught is hidden curriculum (Stone, Barlow, 42).

While we are able to perceive these values, albeit unconsciously, they do affect our perspective on life. Anne Taylor writes about a similar idea which is called the "knowing eye" (xvii). She states, "Developing the knowing eye means temporarily suspending the past, opening

ourselves to new possibilities, and choosing creativity over destructive or negative impulses" (Taylor 260). While it is easy to see an environment and accept it as true, we can play with this understanding that it is simply an image of the past with possibilities of a future.

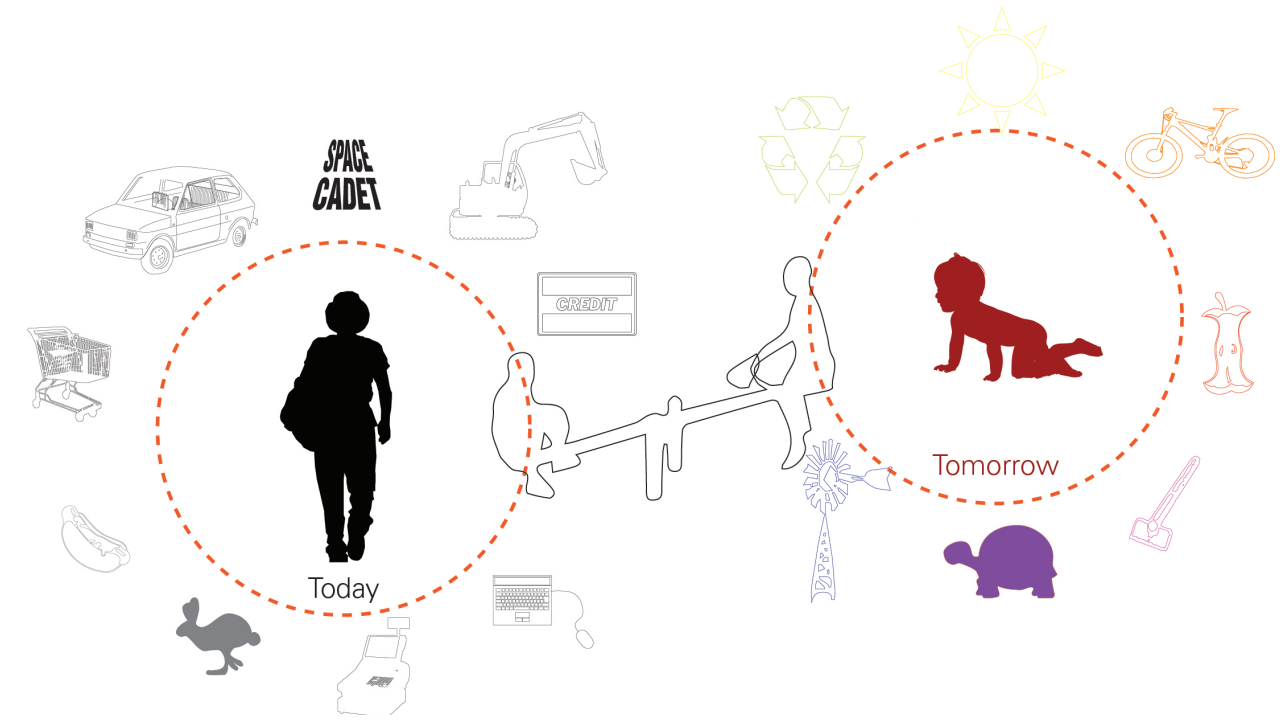

Values are molded by a number of factors including cultural characteristics. Children, through experience and nature, learn these cultural characteristics and feel the need to exhibit similar behaviors or run the risk of being left out. What is exciting about this idea, is that children readily adapt to their environments, as they imagine, question, and explore openly. "Childhood is often the first place where we begin to see and use the environment imaginatively" (Wilson, Ellis 40-1). A further example of how children perceive their environment, but in comparison to adults, can be highlighted in a scenario of a child and adult walking into an elementary school building. The perspective each has on the school building would likely be different. The child may perceive the school through smelling, touching, listening, and seeing the environment whereas the adult would have preconceived notions based on their personal experiences leading them to a biased understanding. There are a number of values perceived by the child that are loud and clear, but have become obscured to the adult through experience and learning. The principles of Reggio Emilia, an approach to learning that is further explained later in this thesis, are aligned

Visible Structures

with these differences among children and adults as one article states, "If we interpret these principles [of Reggio Emilia] in light of research on children and place, we find that a Reggio Emilia approach to the role of the environment in teaching and learning draws deeply on how young children perceive and use space to create meaning... From a child's point of view, an environment is what the child can make of it. Children will often find uses for objects and spaces that adults do not anticipate or intend" (Wilson, Ellis 41-3).

This difference between child and adult learning can also be seen with respect to time. Time is relative. To a grandfather, five minutes goes by in the blink of an eye, he is busy thinking about 70 years of experience, of life, what it all means, and with countless memories all firing to create a world that he and the collective have made true. To a five year old, however, five minutes can seem like an hour or five hours, with each new experience only starting to create a reality. With few memories and an expanding brain, the child is experiencing each second without many preconceived notions and this is continually shaping their identity and their values.

Visible structures are the tangible parts of a system as they are comprised of the things that we can perceive in our environment. Like invisible structures, they shape a perspective of reality and give meaning to our lives. Visible structures include trees, bridges, plastics, food, animals, electronics, and much much more *stuff*. Since these structures are tangible, they are more easily changed. For example, we can rip out counter tops because of the way they look and add new ones, we can change material properties to fit new purposes, and we can tear up asphalt and plant perennials in a park for aesthetics and storm-water detention. There are many ways we can change our environment, but the question is: how and for what purpose?

background ■

The built environment is one of the most prominent visible structures that people experience on a day to day basis in modern society. It has both form and expression. It is a form that through the use of materials and space creates a new environment that people can experience. It is an expression of the values that societies hold dear. We perceive this form and expression with all of our senses. It is in our urban landscapes, where the majority of people now live, that these forms and expressions are loudest. These places are comprised of networks of paved roads, train tracks, and airports; all of which enable mobility. They are divided into small plots with similar building types enabling standard solutions, driven by wealth enabling trends, and they are technologically dependent which enables a lack of dependence on nature. We are creating many of the problems we face because of our societal values. Our solutions, therefore, are never able to get to the base of the problem since we are currently incentivized to meet unsustainable values. This is inevitably a cyclical pattern of problems and solutions and we are running out of time to repair our connection to nature. We need to start shifting our perspective of what is valuable.

Much of what we see in our built environment are designs that have been shaped by invisible structures such as building and land use codes. As previously mentioned, these are affected and shaped by our values. Like other invisible structures, these are often hard to change where there isn't a will to do so. We currently see many progressive and ecologically mindful designs from countries that value such things, and therefore, have building and land use codes that allow such things (Abdelhamid). While we are seeing trends that appear to be more "green" in the United States, we aren't changing the root of unsustainable development through our building and land-use codes. For example, we are finding incentives for programs such as Leadership in Energy and Environmental Design (LEED), which provides a checklist of ways to do less harm to ourselves and the environment. (LEED, US Green Building Council). While this is a step in the right direction, the system is still left unchanged and we are still relying on incentives rather than a deep connection for ourselves and the environment. How then can we start to create environments that evoke this type of deep connection?

perspective & perception ■

Perspective: a particular attitude toward or way of regarding something; a point of view.

Perception: the ability to see, hear, or become aware of something through the senses.

Research has shown that the environment has a very real affect on our physical and mental well-being (Louv, 46). The most obvious example of this is the theory of evolution. Naturalist and geologist, Charles Darwin's work has had profound implications for our understanding of our place within this world suggesting our very real biological connection. Richard Louv, author of "Last Child in the Woods" presents evidence supporting the idea that more natural settings and exposure to these types of environments have real quantifiable effects on our physical and mental well-being. According to Louv, people tend to heal faster and feel better in hospital settings that have views of nature, and kids and adults with learning disabilities or mental illness show signs of improvement while gardening and taking care of animals (45). Another example of this can be seen in our prison system where inmates are

often exposed to little or no nature, thus demonstrating how the lack of a natural environment is a punishment. We are putting people in a cell where all of their perceptions are numb, it is the hope that their perspective will change in this type of environment. In other words, perception can help change our perspective. Louv reiterates this idea as he states "...research revealed Michigan prison inmates whose cells faced a prison courtyard had 24 percent more illnesses than those whose cells had a view of a farmland...Gordon Orians, professor emeritus of zoology at the University of Washington, says such research suggests that our visual environment profoundly affects our physical and mental well-being" (46). This evidence of nature having qualitative effects on human well-being is becoming more apparent and businesses are starting to capitalize on it. Businesses are creating environments that feel more natural and give the user or client sounds, smells, textures, and views that mimic the natural world. Many of these types of places are often viewed as retreats or luxuries, and these should be the norm, not the exception. (The Economics of Biophilia).

If we look at our cities, our learning environments, and many of our homes, it is clear that our goal is not the preservation of nature, but rather fast and cheap solutions to obtain a standard of living that we have come to expect in the western world. To obtain this standard, there is a path to be followed and it is generally viewed that higher education will enable this path to open. It is difficult, however, to deny this path that leads to our wants when we are each given a relatively short time on the earth. We all want to have the best experiences and leave a lasting mark on the things that matter most. Our desires aren't wrong, they are just misguided; they are the fruits of both the visible and invisible structures within the environment and society. There is a need to redesign our values with our current situation on Earth. In order to preserve our sustenance and good lives, we must value our sustenance and good lives.

Education

The public education system in the United States is not working. At both the federal and state levels, the objectives for learning are influencing programs to place competition as a determinant factor among students. Before mandatory education, we would be educated by our parents and community. Our training and understanding on how to survive and what was important was as good as the stories and teaching that both our community and environment imprinted upon us. Since the inception of education in the United States, we notice that education has had the primary objective to create a population of people who are equipped to take part in the changing needs that our society brings (American Educational History Timeline). These changing needs are often the cause of major social events or new ways of looking at the world, and they often spark change in education policy. While we would assume a drastic change in education to take place in the last fifty years, due to the unprecedented amount of change in our environment, not much has changed for the last hundred years or more.

While some areas of education have changed and improved in the last one hundred years, including an expansion of accessible and equal education, we are finding that even with more access to education, we are still not achieving the Department of Education's mission which is: "To promote student achievement and preparation for global competitiveness by fostering educational excellence and ensuring equal access" (Mission). The United States is falling behind many other countries in terms of student performance within similar subject matter (International Comparisons of Achievement). This suggests that the problem isn't access to education, but rather the way we educate. Furthermore, if our main goal is to be competitive in the global market, it would be more beneficial for our education system to focus its efforts on securing and preserving our resources while creating the best environments for learning that are free of cost so that all of our citizens can learn to be the best global competitors they can be!

The goal here is not to proselytize that we need to act a certain way, do certain things and save the world, but rather, give children their right to express themselves, learn by exploring their environment, and investigating their curiosities. After all this, I wouldn't be surprised if these children came to conclusions and designs that benefited the environment they experience.

What are the dangers of education? There are three that are particularly consequential for the way we live on the earth:

(1) that formal education will cause students to worry about how to make a living before they know who they are,

(2) that it will render students narrow technicians who are morally sterile, and

(3) that it will deaden their sense of wonder for the created world.

Of course education cannot do these things alone. It requires indifferent or absentee parents, shopping malls, television-MTV-Nintendo, a culture aimed at the lowest common denominator, and de-placed people who do not know the very ground beneath their feet. Schooling is only an accomplice in a larger process of cultural decline. Yet, no other institution is better able to reverse that decline. The answer, then, is not to abolish or diminish formal education but rather to change it.

-David Orr

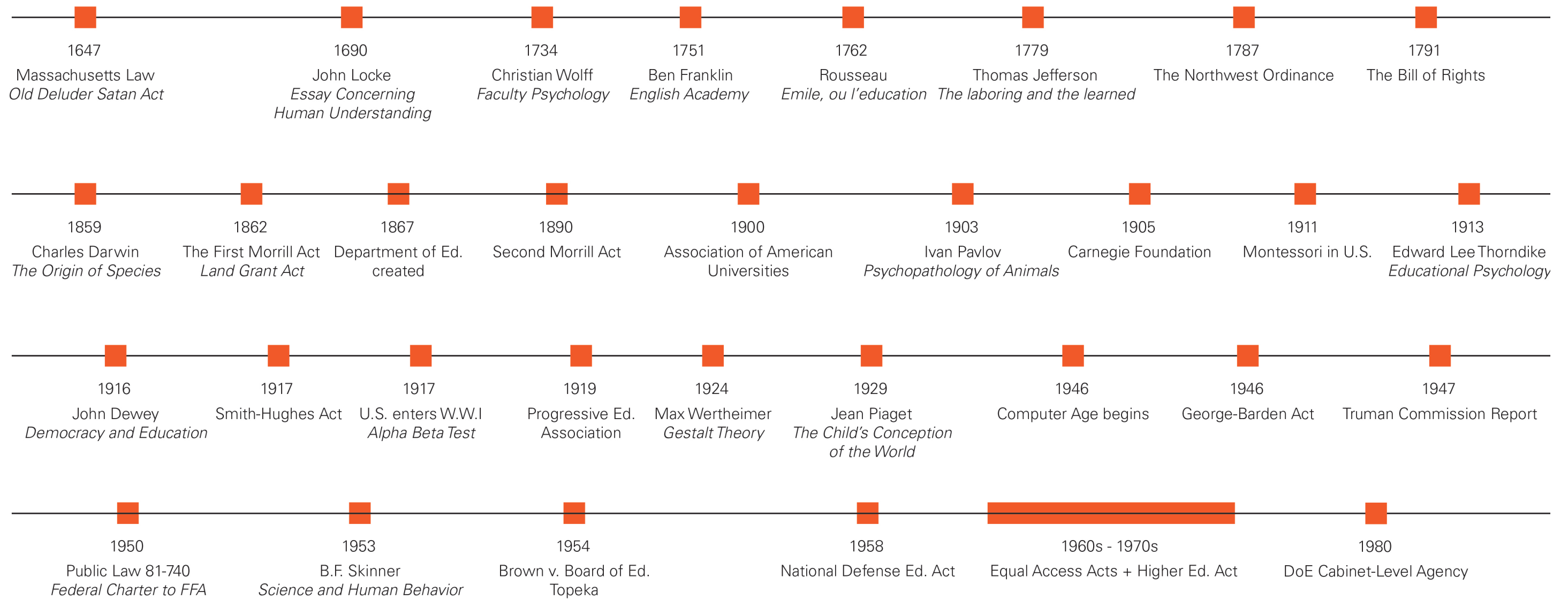

Department of Education's Official Mission Statement: *to promote student achievement and preparation for global competitiveness by fostering educational excellence and ensuring equal access*

Besides the fundamental problems that an education with a mission to be globally competitive has, it requires that we value jobs, money, and technology over family, community, and time.

-David Orr

THE METHOD

It is not the job nor the right for one person to proselytize how someone else should live. There are many understandings to the world and life itself, and the sharing of these understandings is what makes life so beautiful, diverse and abundant. This thesis explores a method to provide a framework for communities to plug in their own needs and culture to elementary education while promoting a balanced environment for a sustainable future. Fritjof Capra points out that nothing is or lives in isolation, there is always a network or community needed to have life (Stone).

The method explored is a permaculture-based pedagogy for design. It takes into account a number of factors including the developmental needs of children, methods of teaching and learning, a curriculum to support children's understanding of the building blocks of life, as well as a systems approach to design. These factors create a framework that can then be implemented into a specific place. Once we have the context then the framework expands to include the community and culture, climate, and ecology of that place. Only after each of these factors are observed and described, the design can start to take form. The holistic design will create an environment that is suited to the needs of the children by responding to the context, and is ethically derived to make a positive impact on children's learning and development.



Goals Articulation

The challenges that this thesis confronts are to provide a place for learning where children explore the culture of their place, where children sense their connection to the environment, where children are active members of their community, and where children are given an environment that is suited to their developmental needs .

Like many schools across the nation, Corrales Elementary provides a campus and curriculum that is centered around textbook memorizing. Analogous to how we have been building for the past hundred years, learning today is not rooted in place. Our environments and education are largely delivered as a one-size fits all approach.

This thesis will explore a framework for design that provides environments for children to explore the natural world and allow them to connect to the very small and the very large systems that create and sustain their place. This framework for design can then be implemented globally and suited to place when designing elementary schools. Creating a holistic framework will allow the designers, clients, community and children to see the impact that we can have on our surroundings and question our actions to see if they fit within an ethical framework rooted in place. Every person is different and every person has a different way of learning, doing things, and experiencing the world. Providing an environment that allows these diverse learners to be excited and want to keep learning will promote people who are active, not passive, and people who can problem-solve and take care of themselves so that they may contribute to their community.

Through the design and process, this thesis aims to create a close relationship between the school and the community. The connection would promote a more resilient community by creating more connections, while also inspiring a sense of pride in place. Many children grow up wanting to escape their community. We view nature as a similar escape from the cities that have none, but this is not a sustainable solution to our social and ecological problems. We can start creating places that combine nature and community if people are rooted in place, understand their connection to nature, and are proud to be a part of their community.

At the Center for Ecoliteracy we believe that at their heart, the ecological problems we face are problems of values. We've noticed over the years that it's very hard to change the values of adults, while at the same time we've noticed that children are born with certain values intact--namely their sense of wonder and their affinity for nature. David W. Orr reminds us that the biologist E.O. Wilson calls this 'biophilia.' We all share that trait, but it seems particularly strong in children. It's undiminished when they're young. And one of our philosophies is that we think that, properly nurtured, biophilia can develop into ecological literacy and eventually lead toward a more sustainable society

-Stone, Barlow

Children

Children are sponges who soak up and imitate what they observe in their environment. They are naturally curious and show a deep understanding of the world through their perception. We are stifling children's ability to learn by giving them a factory model of learning, an environment suited to robots, not children. Instead, we can design learning environments that honor and support children's potential, their innate needs, and intrinsic characteristics.

Through the work of many great minds and much time observing children, we see that children generally possess similar developmental milestones. Jean Piaget, a Swiss psychologist, has done extensive research into child development and has asserted when these milestones occur as well as what processes are forming and should be nurtured. This thesis will use his framework as a basis for understanding how to design environments that would promote children's social, cognitive and physical development (Cherry).

The beginning of everyone's life started as a child. This is the root of ourselves and the start of our understanding and relationship with the world. Our ability to change our perspective of our relationship with the natural world starts with our children. This is a great place to start since children are born with what E.O. Wilson calls "biophilia" or "the urge to affiliate with other forms of life" (Louv, 43). It is rare that people will protect or provide for things that they have no experience of or relationship with. Therefore, providing an environment that will further children's intrinsic characteristic to want to be around other living things, we can connect children to nature, their community and their needs in the place where they come to learn; their school. So the question then becomes, how do we teach them (process), what do we teach them (content), where do we teach them (place), who teaches them (community and environment) and of course the why do we teach them has already been established; to reconnect people to the source of their sustenance and good lives so that we may all thrive and become people who are decent members of their communities.



Experiential Education

To begin developing a learning environment, an exploration is needed to understand the difference between the what and the how to educate. The what is the curriculum, it emphasizes the subject areas in a study and this is only one side of the coin. The other side is the how; the pedagogy or approach to learning. Richard Louv makes a great distinction between these two sides of the coin, “While environmental education focuses on how to live correctly in the world, experiential education teaches through the senses in the natural world” (203). The use of our senses is our natural way to understand and react to our environment, it is a way that each individual can bring understanding to their environment for and to themselves.

Experiential education is inherently rooted in place. Children are not inspired to be confined to a desk, not to mention inefficient classrooms and buildings that have no relationship to their context. The substitution of learning through doing and experiencing with learning through books and computers has made children complacent and often not invested in learning. With new technologies increasingly entering into schools at younger and younger ages, children are able to see within an instant what is happening all around the world, while they are simultaneously disconnected from their other senses. Their eyes tend to give a fleeting understanding of the situation as they flip the screen to the next image or simply turn off their learning until otherwise notified that class has *begun* again.

background ■

The natural world has been developing and reacting for the past 4.5 billion years. In contrast, the human mind has only a few thousand years of experience. Nature is a great teacher and a great listener. We, as a species have only been able to survive by working with nature, creating a relationship and honoring that relationship. For the past couple hundred years we have started to turn our backs to the natural world, finding ways to control it for our own benefit. The only problem is we have tried to bottle something that cannot be contained; dynamic balance is inevitable and we should be adjusting accordingly.

We are born capable of sensation and from birth are affected in diverse ways by the objects around us. As soon as we become conscious of our sensations we are inclined to seek or to avoid the objects which produce them: at first, because they are agreeable or disagreeable to us, later because we discover that they suit or do not suit us, and ultimately because of the judgments we pass on them by reference to the idea of happiness or perfection we get from reason. These inclinations extend and strengthen with the growth of sensibility and intelligence, but under the pressure of habit they are changed to some extent with our opinions. The inclinations before this change are what I call our nature. In my view everything ought to be in conformity with these original inclinations.

-Émile, Book 1 – translation by Boyd 1956

Experiential education has been emphasized as an important process for learning by many notable people including Rousseau, Carl Rogers, Maria Montessori, Albert Einstein, John Dewey, Paulo Freire, David Kolb, Loris Malaguzzi, among others. It is the active engagement of discovering and doing for the self that connects to the intellectual, social and physical processes that makes experiential education so powerful. It allows us to continually learn rather than take another's experience and reflection as true, having never felt or figured it out for ourselves.

While there are many approaches to experiential education that can be implemented as a pedagogy, Reggio Emilia is one approach that does a good job at being a product of place, developing the whole learner, empowering children with their rights, and allowing them and ourselves to discover the world together each and every day.

Reggio Emilia ■

Reggio Emilia is an approach to learning that began shortly after WWII. Parents in northern Italy sought a separation from the church to create a place to teach their children how to be critical thinkers and active members of their community. Through their teachings, these parents hoped their approach to learning would foster students who would ensure a democratic state (Community School). The philosophy that comprises Reggio Emilia was therefore established and currently exists in a unique political, economic, cultural and historical context. The approach was designed by members of the community realizing the need for change and hoping for a brighter future for their children and their community. Today, schools who are founded on the same approach are said to be "Reggio inspired" since they are not a part of that same context. What this implies is that while there may be certain universal truths, every place is different, has different needs, hopes, environments and histories and we should be taking these factors into consideration rather than applying one solution to many different problems and circumstances.

Besides being a realization of a unique context, Reggio Emilia considers the importance that each and every child brings to the table as well as the importance of both the constructed and natural environment to learning. In a seminar in Reggio Emilia, Professor Loris Malaguzzi, founder of the Reggio Emilia philosophy, asserted that, "The environment you construct around

you and the children also reflects this image you have about the child. There's a difference between the environment that you are able to build based on a preconceived image of the child and the environment that you can build that is based on the child you see in front of you" (Seminar 3/94). This idea of a preconceived image of the child is a great way to look at how we tend to classify and categorize children to be the same. In reality, life, including children, are much more complex and each come from different backgrounds. Creating an environment that reflects this complexity can be difficult. So, what are we to do?

Just as there are universal characteristics in species who share similar traits, children have similar levels of development. The difference between children is in their own backgrounds and understanding of the world. To allow these differences to flourish so that we may live in a world full of ideas and meaning, we must acknowledge the rights that children have. Malaguzzi writes of the various rights that children have including, but not limited to: the right to a good school—building and teachers, the right to imagine, the right that we (adults) believe in their intelligence and strength, their beauty and ambitions, desires and request (Seminar 3/94). Without these rights, children are taught what is right and wrong when it is their own right to understand and question what is right and wrong. They have the ability to learn for themselves and we can provide guidance when they need a lending hand. This type of relationship between teacher and student fosters life-long learners who are able to problem-solve for themselves and flourish to their own capacities. This relationship also introduces the teacher as co-explorer and learner, observing the children's interactions with their environment and documenting their experience which can then be used to share and reflect on the process of learning.

Collaboration is key to Reggio Emilia. Children are emphasized to develop social skills and build relationships. Through the careful observation of student interests, teachers deliberate over possible directions for projects, and plan how they might incorporate the environment and community within the project-based study of a concept or set of ideas. All of these components describing the philosophy of a Reggio-based approach to learning helps to inform what is described as the "third teacher" or classroom environment (Malaguzzi, seminar 3/94). This environment includes: flexible spaces, natural materials, a variety of tools and surfaces to express themselves, as well as an overall aesthetically pleasing environment. The "third teacher" is paramount to developing a holistic learner rooted in place.

Ecoliteracy

While we saw that the Reggio Emilia approach to learning empowers the child to learn based on their own interests, a curriculum that circles back to the fundamental aspects of life or Ecoliteracy, could help children see how their interests are tied back to living systems including themselves, their families, their community, and the environment. Learning from nature, we can see that the components that make up life is a network of organisms that interact with each other. Humans are no different, we are a part of this network and we can learn from the other components by looking at the make up of our societies and the needs for them, and mimic what nature does best. Nature is the greatest teacher of all with diversity and balance that humans have a hard time reproducing.

Within our globalizing world, we are becoming a mass agglomeration with few differences. More of our lives are becoming standardized, applying one size fits all solutions to a diverse set of problems. In reality, each place is distinct with regards to its ecosystem, history and culture, and climate. We would imagine that our schools and the built environment would reflect these characteristics, but instead are mostly found to be out of context. Moreover, with an increase in the number of natural disasters affecting communities, nature's way of balancing itself, reacting to our constant draw and pollution, we no longer have the knowledge nor the resources to create resilience and repair without relying on our cities and federal governments. This reliance inevitably creates dependencies on systems that are not prepared to support everyone who may be in need. Instead of relying on someone and someplace else to support our communities, we have the knowledge, the experience, and each other, to conserve, regenerate and steward the environment and therefore ourselves. This knowledge and shared experience can begin to develop in our schools, the place where children come to learn.

Similar in approach to the founding of the Reggio Emilia philosophy, Ecoliteracy in conjunction with supporting our children's inherent curiosity, can start to create communities that have resilience and local knowledge. Much of our daily lives today in developed and developing countries rely on processes that distance us from each other and from nature.



- 12 | Reggio Emilia, Italy
- 13 | Corrales, New Mexico, acequia farming as expression of place
- 14 | Moab, Utah, rocks as an expression of place

Advanced technologies require dependence on specialized knowledge and manufacturing. Processed foods creates communities that are dependent on large scale manufacturers and agribusiness. Buildings that do not reflect local traditions and methods rely on materials processed somewhere else and people who are highly specialized. Hardly anything anymore is needed or dependent upon the local community and therefore, we don't need to know our neighbors or the soil or the ecosystem. Therefore, why would we invest time in the things we don't visibly or quickly need like an understanding of networks, nested systems, cycles, flows, development or dynamic balance, or "principles of ecology" (Stone). These concepts provide a foundation for understanding the world and processes that are inherent to our being. Without such a framework, it would be hard to assume that anyone make a choice that may require more work or a restriction of self indulgence over ease and immediate satisfaction. However, if that person were to experience and start to understand their choices and the effects they have on their environment, we may expect an ethical framework. This could act as a way to support both nature and our human needs, as well as to start forming and providing guidance in much the same manner as the teacher provides guidance to the students in a Reggio Emilia environment.

Permaculture

In a sense, permaculture is a way of life that's ahead of its time while also taking us back to how our ancestors lives, sustainably and within their ecological means. That doesn't mean we can't live in comfort and utilize current technology in permaculture lifestyle. Permaculture gives us the tools and techniques to live sustainably while still having our needs met in a lifestyle rich with healthy food, comfortable housing, and renewable energy and resources.

Permaculture is similar to both architecture and engineering in that it is a design approach first and foremost. Whether we are designing a house, a chicken coop, a garden, a bowling alley, or a schoolyard, permaculture is a process that starts with a problem and finds solutions. In permaculture, design decisions are first based on ethics and then incorporate the logic of natural systems. Mimicking nature's patterns makes our lives more sustainable and less reliant on resources outside of our control.

In contrast to living in a wasteful, consumerist manner that depletes our resources and doesn't leave future generations much to work with, permaculture is about building resilience and using only what we need and what we have access to—in other words, living within our ecological means. It's about building fertility and abundance. It's about designing and building systems in our lives that work together to provide food and water and energy, that reuse waste, and that make life easier. It's about making these systems beautiful and inspiring, and by doing that, making our lives healthier and better overall.

In a nutshell, then, permaculture can be defined as meeting human needs through ecological and regenerative design.

-Bloom + Boehnlein

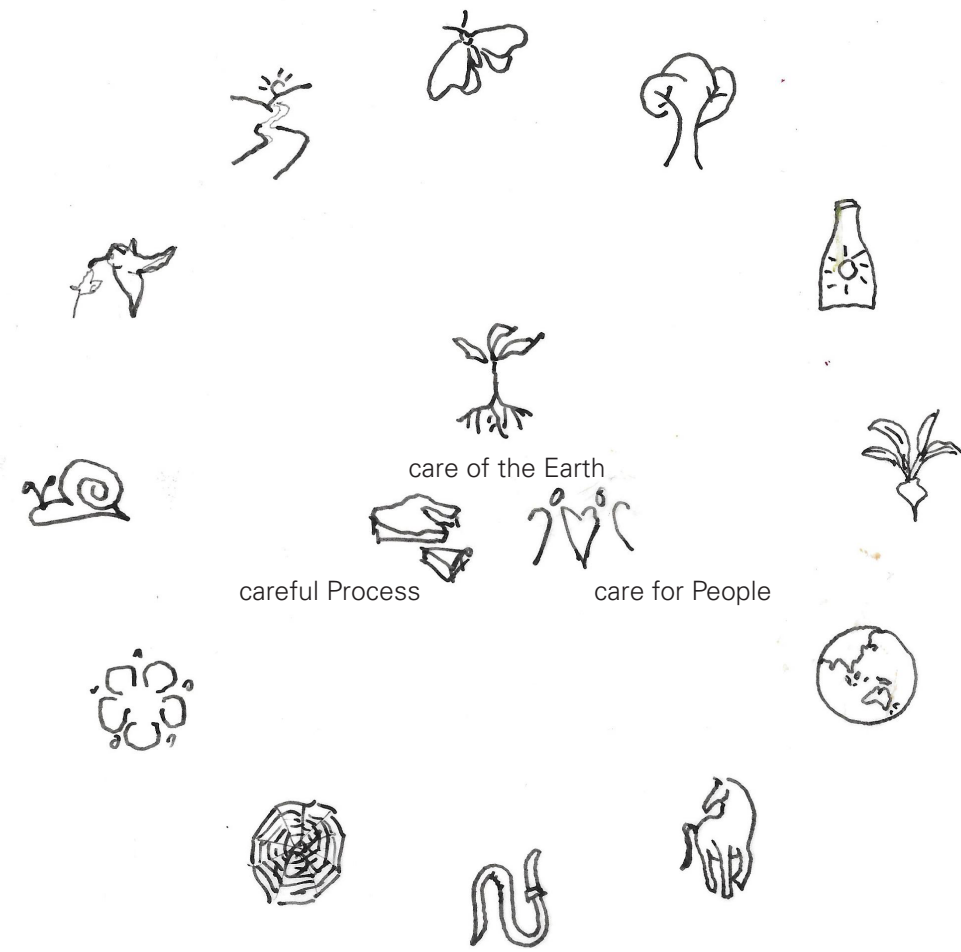

The permaculture principles surround the ethics at the center of the circle. Like a clock starts a new day, the designer starts at the 12. As the designer moves clockwise around the circle designing solutions, he or she checks these designs with the ethics for guidance, by the time the clock strikes 12 again the design is likely to be a more holistic solution that accounts for both human and environmental needs.

The ideas that permaculture embody have been around and used for thousands of years, but it wasn't until the mid-1970s that Bill Mollison and David Holmgren decided to create a design methodology that brings ethics and sustainability together with the intention of creating a more healthy and abundant life for all to share (Bloom, Boehnlein, Intro). Like many things worth doing in life, permaculture takes practice. It is not something that we do only when we are at work and then turn off when we get home or visa-versa. Rather, permaculture is a way of life that inherently makes people shift their perspective from the way we currently do things to asking questions of why we do them and what are they in turn are doing to or for us.

When we start to ask questions about the choices we make, we start to see stories that are being told all around us. Within these stories are values and roles that are exuded by the world around us. There are always multiple stories being told and listening to them informs us of what is important and what we can do to either plug into or change the story. Currently, one of the largest stories being told is about global warming. Within this story is the idea that we are destroying the environment, and that nature is *out there* beyond our daily lives. Another story can be called "business as usual." Within this story, there are lots of unspoken privileges and some of the players in this story include the media and marketing. This story tells us that to be successful you need a large house, a good car and lots of stuff. The idea then is to thoughtfully and critically examine these stories to see whether they align with the type of relationship needed to have a sustainable community and lifestyle. The ideas and values that permaculture bring is simply a shift in perspective, yet not unlike the shift that took place during the enlightenment, but rather a continuation of the enlightenment with regards to the context and needs of today.

There are about 7.5 billion people on the Earth, but we have only enough resources for about 2 billion people if they all lived like we do in the western world. This fact raises questions about how we are living in relationship with the world. There are boundaries to our living, but we are using our resources as if western expansion were still a reality today. Being that it isn't, we need to ask what our basic needs are and how we can design to meet those needs. What makes permaculture different from other design methods is its foundation in ethics. These ethics can inform design decisions that are less about the self-interest of the designer or client and more about what is best for all parties that the design will affect, including the client, the

community, the environment, and so on.

One of the key tenants behind permaculture is to simply ask questions. These questions then get filtered like water through a filter (ethics) to make sure that the solution is as pure as it can be to meet its preconceived goal. Much of our current technology puts us in a predicament of whether we should use it or not. It makes quick labor, but at what cost? If an excavator is used to remove soil to get to precious metals next to a river and this fills the pockets of a company that lives thousands of miles away and doesn't care of their impact on the community, then this is ethically questionable. At the same time, since we have the technology, if that same excavator is digging up soil to create a berm for a preschool so that the children will be comfortable in an arid climate, the embodied energy in the use of that excavator may be beneficial when compared to the amount of work it would take to move the same amount of earth with a shovel. What permaculture design strives to achieve are ethical designs that the economy or self-interest can't answer alone. There isn't a right and wrong way of doing things, rather it is an approach that asks questions, guides further study, and comes to a solution that is more often than not a systemically holistic design.

One set of permaculture principles, that have been adopted by many within the permaculture community, are a set of 12 concepts that act as a great starting point when thinking about designing with systems. These include: observe and interact, catch and store energy, obtain a yield, apply self-regulation and accept feedback, use and value renewable resources and services, produce no waste, design from patterns to details, integrate rather than segregate, use small and slow solutions, use and value diversity, use edges and value the marginal, and creatively use and respond to change. These principles are a starting point and not the only means of generating an appropriate design, whatever way we can come to a design that works with systems that promotes a balanced solution for the earth and ourselves, is more than acceptable to be thrown on the table.



Observe + Interact

- Insurance against senseless mistakes
- Not just traditional solutions, observe what is there and what is the best way to use it
- Helps us slow down in design and provides an opportunity to question what we think we know
- Notice patterns and provide the smallest intervention for greatest effect
- Interact, we can't design in isolation



Catch + Store Energy

- Need to understand energy flows
- Many ways to capture and store energy (rocks, water, seeds, solar, culture, etc.)



Obtain a Yield

- There are many different types of yields (money, crops, networking, information, etc.)



Apply Self-Regulation + Accept Feedback

- This is a check on hubris
- Accept feedback from many sources i.e. is the design offending people, is there a poor yield and if so why?
- Design solutions with overflows, account for change



Use + Value Renewable Resources + Services

- Examples of these resources include people and plants
- Use biological solutions over technological when applicable



Produce No Waste

- Nature doesn't produce waste, everything reused
- Re-purpose and use ancestral wisdom
- Find multiple uses for things



Design from Patterns to Details

- Think big
- Allow systems to evolve by not filling in all the details, leave shim space
- Understand patterns of social gathering and what breaks social barriers like food and work
- Patterns of movement



Integrate rather than Segregate

- The more beneficial connections we have, the more resilient the system
- What are the roles of all the players in a system and how do they relate?
- Diversity of views
- No mono-culture!



Use Small + Slow Solutions

- Smallest change for greatest effect
- Scale: everything has an effect
- What is necessary to start?



Use + Value Diversity

- Use relationships that work well together, not just a diversity of species, is it a system or just an amalgamation of species?
- Emergent properties



Use Edges + Value Marginal

- There is lots of action and interaction on the edges
- Innovation is not usually mainstream
- Everything has an intrinsic worth, we can't look at just what can be done for us as humans, but whole systems



Creatively Use + Respond to Change

- Everything has a useful life
- 20 yr life, the next generation gets to learn and build and put new touch on design
- Things change, how do we build this into the system?

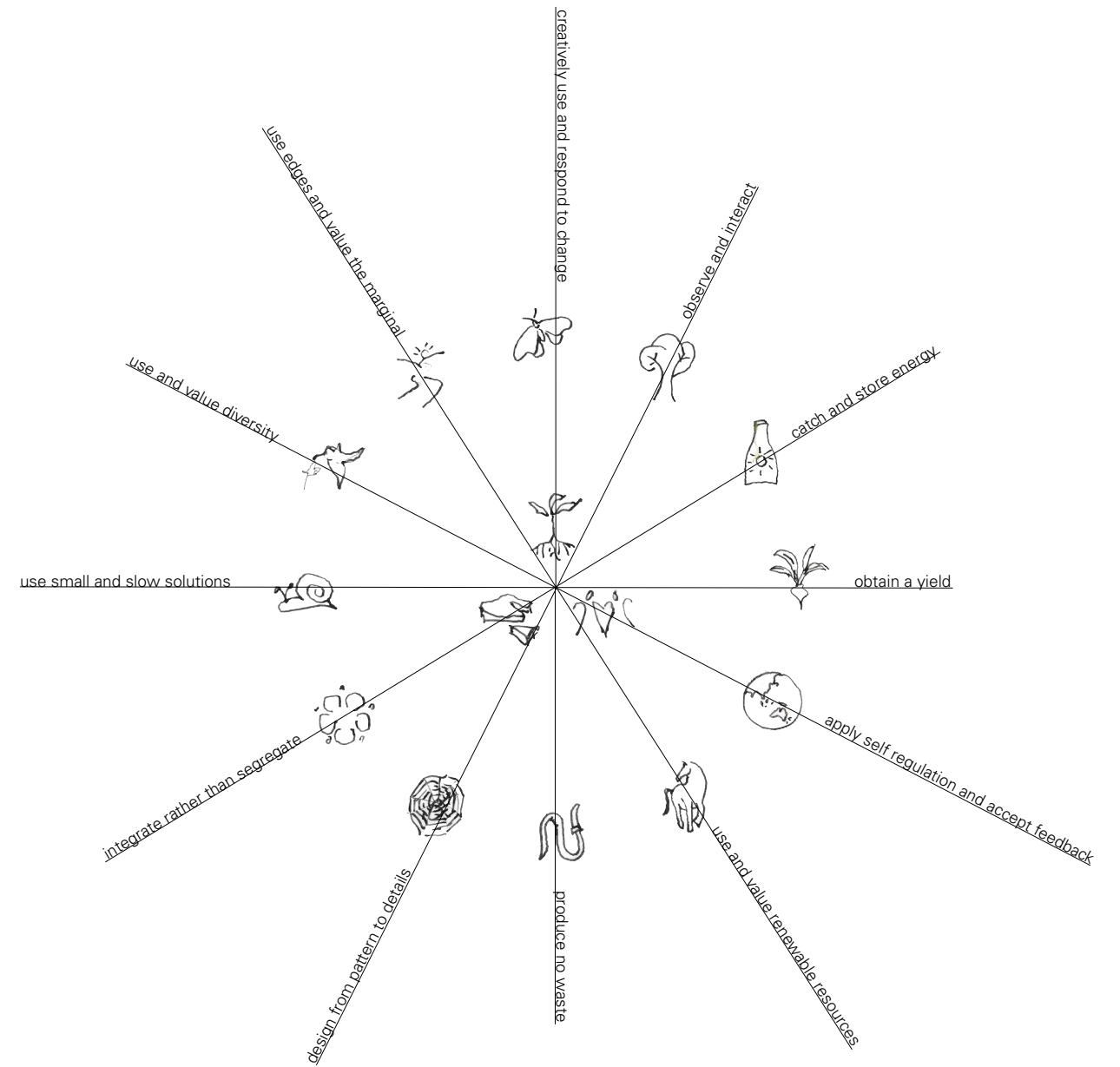

Theory Grounded

There are inspiring educational approaches and environments that are addressing the need to live more sustainably. These precedents offer insights to what is currently happening within the education environment today. In these places, teachers and students learn together, provoking questions and evoking discovery. The fundamentals that these people and environments teach are: life is an elaborate network of systems or communities, and that without understanding the foundational principles that govern all life, societies will have a hard time living sustainably.

The precedents studied show a diverse approach to how we can create learning environments. By selecting a project that is currently in design, the *Academy for Global Citizenship*, we receive an insight into what is at the forefront of environmental education. By selecting *IslandWood*, one of the first LEED Gold projects in the world, we can see how the built environment and natural environment can work together to create inspiring places for learning. Lastly, by selecting *Bullock's Permaculture Homestead*, a project that has been in development for 34 years and constantly being worked on and designed, we can see the power that of community as well as tested solutions to living sustainably and ethically.

The diverse project approaches and programs will lend a hand to begin thinking about an appropriate elementary school design in its own climate and context. Each of the precedents works with the natural flows of weather and site to harness free energy and minimize inefficiencies in the built environment. The precedents have had and will continue to have a major impact on their immediate and larger communities, shining like a beacon of hope that we may yet rekindle our connection to nature.

1. *Academy for Global Citizenship*: Studio Gang



2. *IslandWood*: Mithun



3. *Bullock's Permaculture Homestead*



Academy for Global Citizenship

Studio Gang, Architect
Chicago, IL
Anticipated completion 2018

The *Academy for Global Citizenship* is designed with the intent that sustainability starts at school. Taking a stance that traditional classrooms do not engage the whole student, the site is being designed to have a more fluid and flexible environment where learning takes place on the site rather than solely in the classroom. The site will provide differentiated learning spaces for the developmental needs of the students, 3-acres of growing space that will help offset school lunches, as well as connections to animals to further foster the student's connection to nature. The architecture is situated to maximize solar collection and uses many environmental strategies to minimize drawing upon external sources for their daily consumption needs. This is a big step towards shifting the paradigm from a traditional learning environment to one that will help students become aware of their impact on the earth and create a place to become closer to nature.

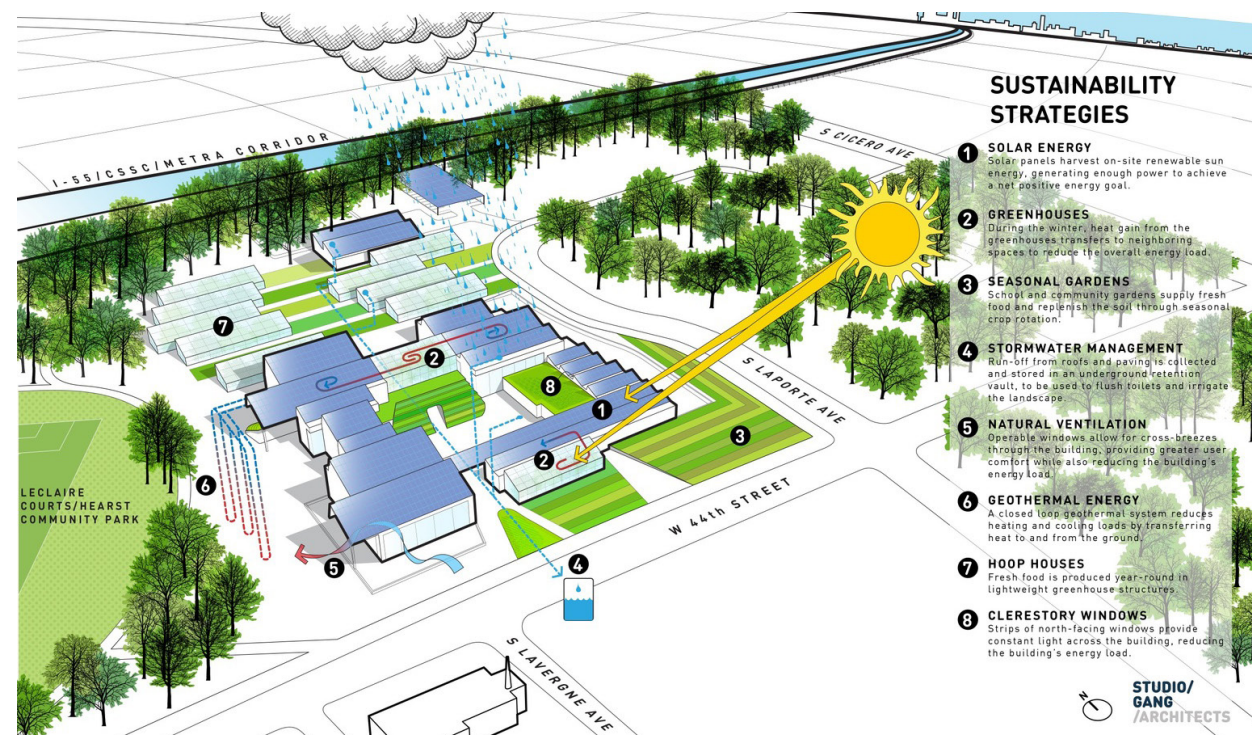

IslandWood

Mithun
Bainbridge Island, WA
Completed 2002

Created as an environmental education center, *IslandWood* focuses on creating an experience for children and adults that embodies the feeling of the outdoors, but with the warmth and comfort of modern building techniques. Self described as "An Educational Sleep-away Experience on Bainbridge Island" (islandwood.org), one of the goals is to give students an environment that allows them to explore nature inside and out. By using the outdoor environment to explore, discover, plant and grow, the students then are able to further their investigations using the tools and comfort of the indoors. Inside they learn to cook tasty treats they just picked outside and they reflect and synthesize their experiences both individually and collaboratively. Using the built and natural environments that have been integrated gives a sense of place, history and culture for the students to soak up and take with them on their journey back home. The experience including compost toilets, a living machine, integrated technology and abundant nature will ideally instill a sense of stewardship and affinity for natural systems.



Bullock's Permaculture Homestead

Bullocks and extended family
Orcas Island, WA
Work in progress since 1981

The homestead is what the Bullocks call an "integrated, holistic approach to land use and development" (Bullocks Permaculture Homestead). For the last 34 years, the homestead has been a testing grounds for designs that maximize growing food stuffs including plants and animals in a way that contributes to the ecosystem rather than degrading it. The family, with the help of friends and collaborators from all over the world, practice the art of making and designing with systems in mind. Over the years they have become quite knowledgeable in a variety of settings and have founded a design consultation group that work with people wanting to integrate sustainable systems practice into their own lives.

On the site, the family hosts visitors, both short and long term, who are interested in learning and getting their hands dirty in real projects, gaining experience and first-hand knowledge. The family also leads a "skill building program," where students stay on site for at least six months learning, working, and being a part of a community that shares common interests. The program focuses on our basic needs including annual gardening, perennial zone management (keeping the soil happy) as well as monthly specializations that range from working with electricity, mechanics, water systems, animal management, building high efficiency heaters, building sheds to building and relaxing in saunas (because we need to take care of ourselves too). This is a great example of a permaculture site that takes care of the earth, people, and understands the importance of healthy systems.



PLACE

Corrales, New Mexico

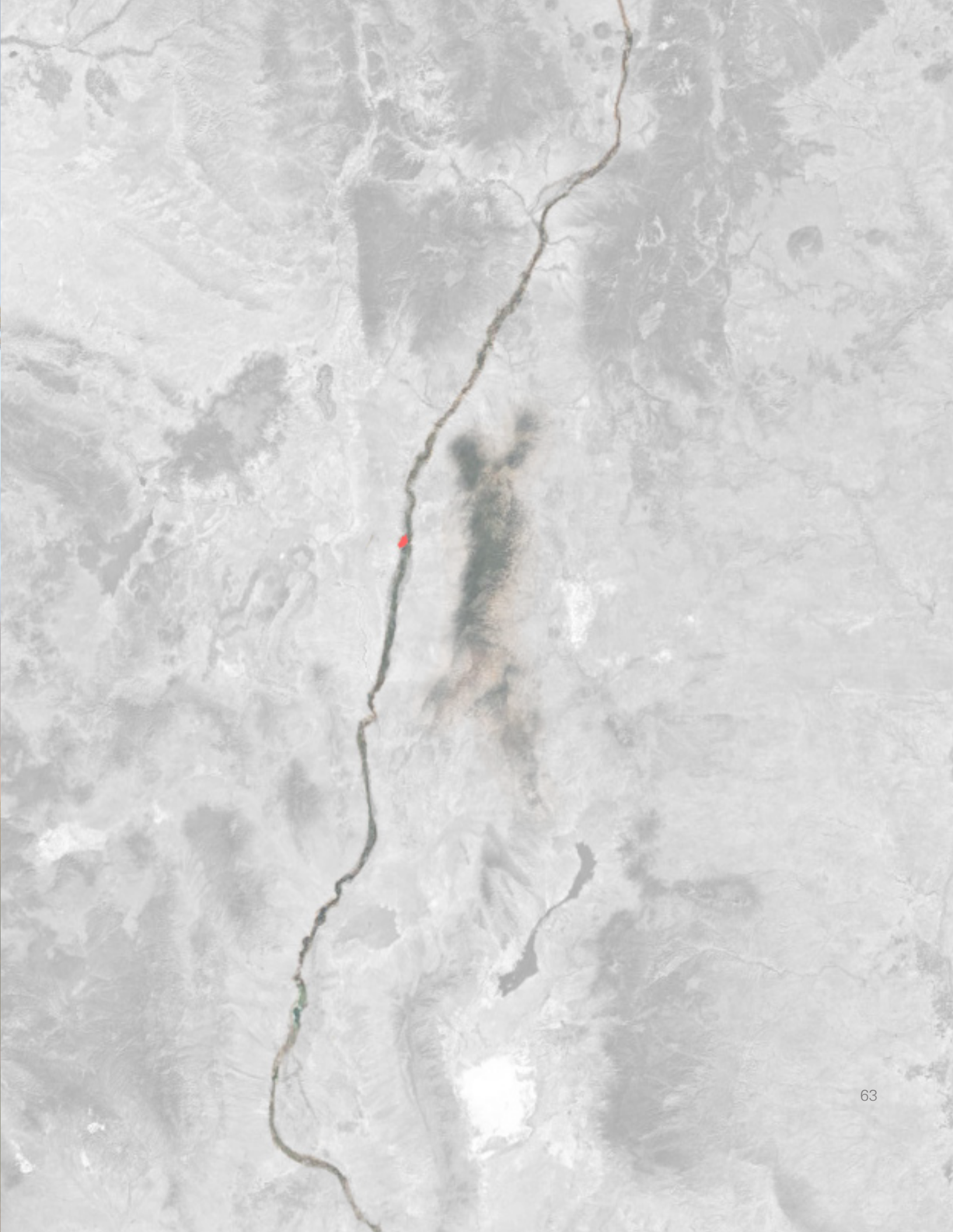

Community and Culture

Corrales is still known as a “village” that is situated along the Rio Grande river near the center of New Mexico. The Rio Grande is the major lifeline of the state, it’s water brings an oasis to an otherwise harsh environment. Due to the life giving force of the river, Corrales has a rich cultural history that dates as far back as the 5th century CE. At this time the Native American Tiguex tribe laid roots and called this place home. By the time the Spaniards arrived in the late 17th century, the Native peoples were said to have moved out of the area and the land was for the taking. In 1710, the Alameda Land Grant was given to Francisco Montes Vigil, a soldier in the Spanish army. Unable to uphold the grant, Vigil sold in 1712 to Captain Juan Gonzales Bas (Village of Corrales Comprehensive Land Use Plan). Soon after, the village was split into a few large ranches and owned by only a few families.

Drawing upon the river, the families divided up the land into long corridors that ran from the Rio Grande in the east to the sandy mesas to the west. The long narrow strips of land allowed people to irrigate from the acequias, or network of irrigation ditches. The acequias were and still are one of the main characteristics that brought the community together to achieve similar goals. Irrigating allowed people to grow a number of crops including chile, corn, and a variety of fruits and vegetables. While the crops were grown close to the source of water, the land along the mesas were used to graze cattle, horses, and a number of other animals. Life went on like this for a while with a small community of families growing crops and raising animals, a lifestyle that can still be seen in Corrales today.

In 1848, New Mexico was attained by the United States. Slowly the area started to grow as European immigrants came into town. Mostly French and Italian, the village expanded its palette of food stuffs to include orchards and vineyards. The population held relatively steady with the new mix of cultures until after WWII. With an influx of people living in Albuquerque, Corrales attracted a number of new residents. The expansion left most of the land to the West to be bought by a developer in the 1960s and turned into Rio Rancho, one of the largest developments at that time.

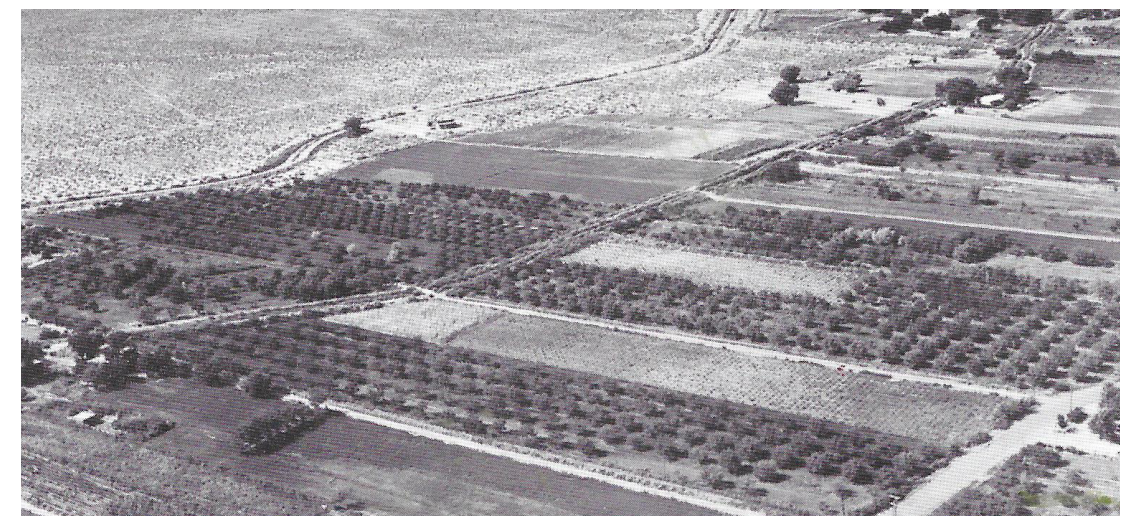
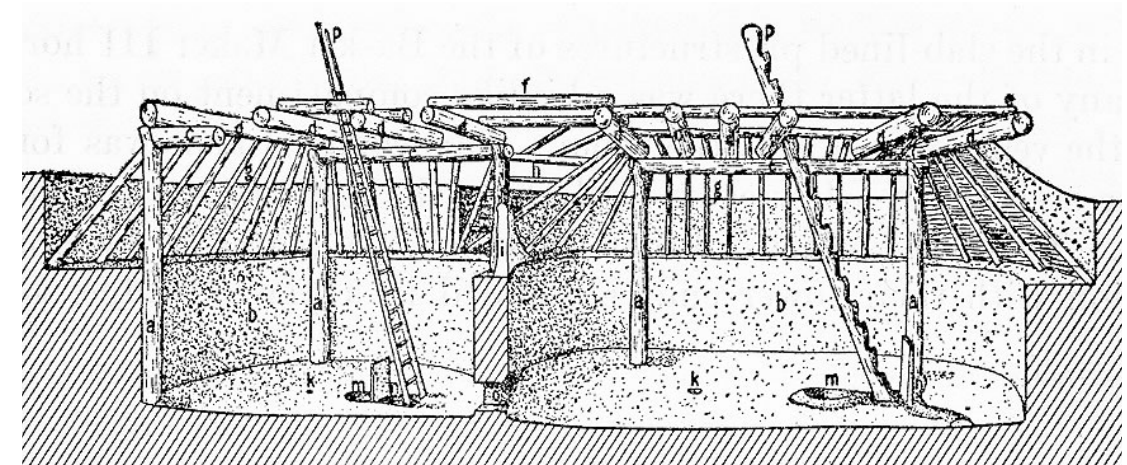

- 28 | pithouse section
- 29 | map of acequias in Corrales, NM
- 30 | watercolor of traditional farming methods in Corrales, NM
- 31 | aerial photograph of the division of land in Corrales into long narrow strips

In 1971, Corrales created its own governing body in hopes of maintaining its own identity from the rapidly growing populations of Albuquerque to the south and Rio Rancho to the west and north. Aimed at creating a plan for future development, the “residents of Corrales have always tried to maintain a strong agrarian sense of community self-support and community self-determination” (Village of Corrales Comprehensive Land Use Plan). These ideas of self-support and self-determination to uphold its deeply rooted agrarian culture speaks to values this community exudes. One point that is contrary to this admirable claim is the history of Corrales’ public elementary school.

1. Farm Town Votes to Save Land and Way of Life.....

The governing body should:

- Encourage, preserve and enhance the rural, agricultural, historical, and cultural character of the village;
- Protect the environment, including open space, the Rio Grande Bosque, the sand dunes, arroyos, acequias, main canal and escarpment.
- Manage development of appropriate commercial activities within the Village which preserve and enhance its semi-rural agricultural character, and its economic diversity.
- Foster sound planning of residential development, including designing a system of roads and streets which is environmentally sound and appropriately scaled to its needs and lifestyles of residents.

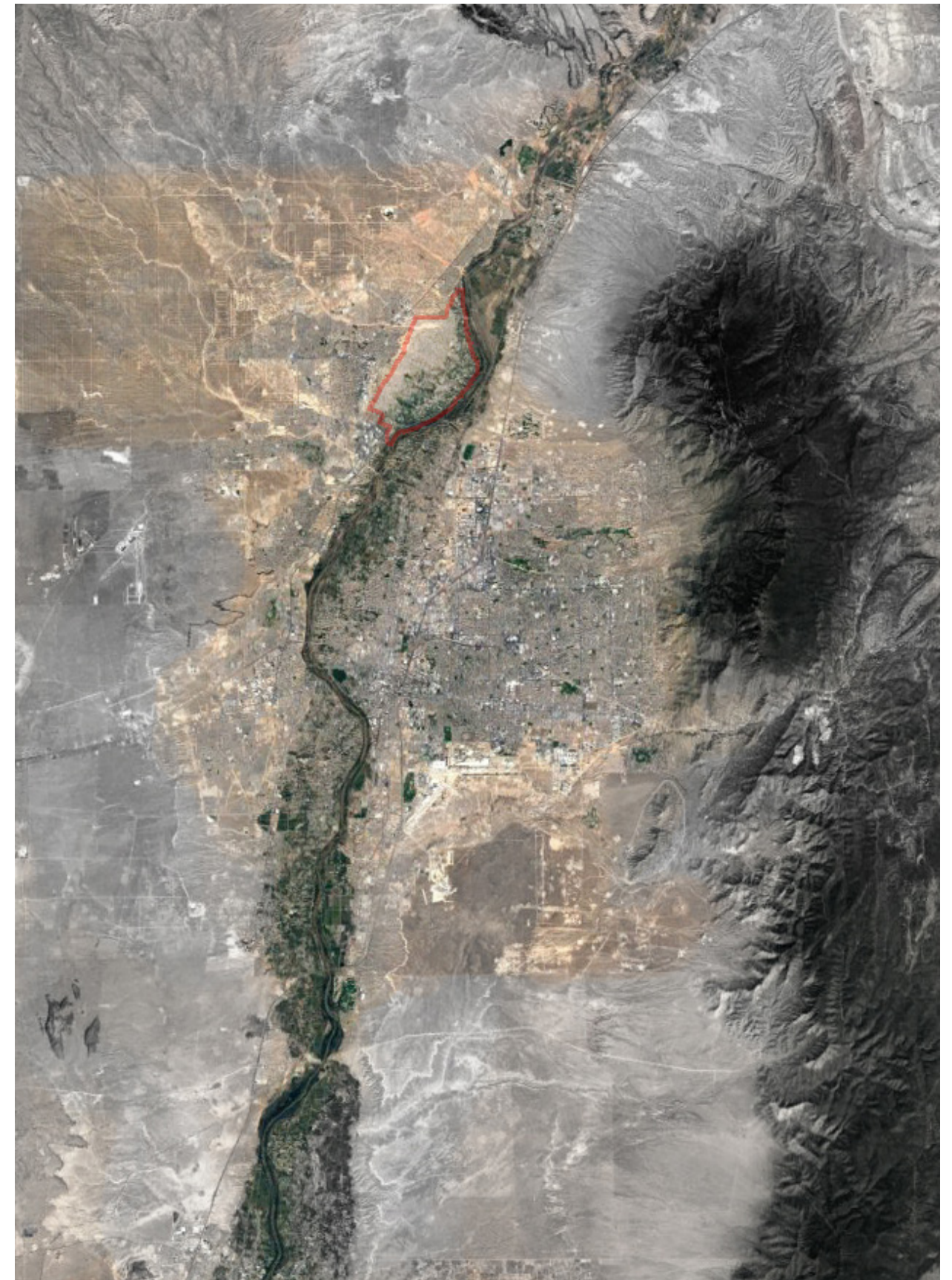

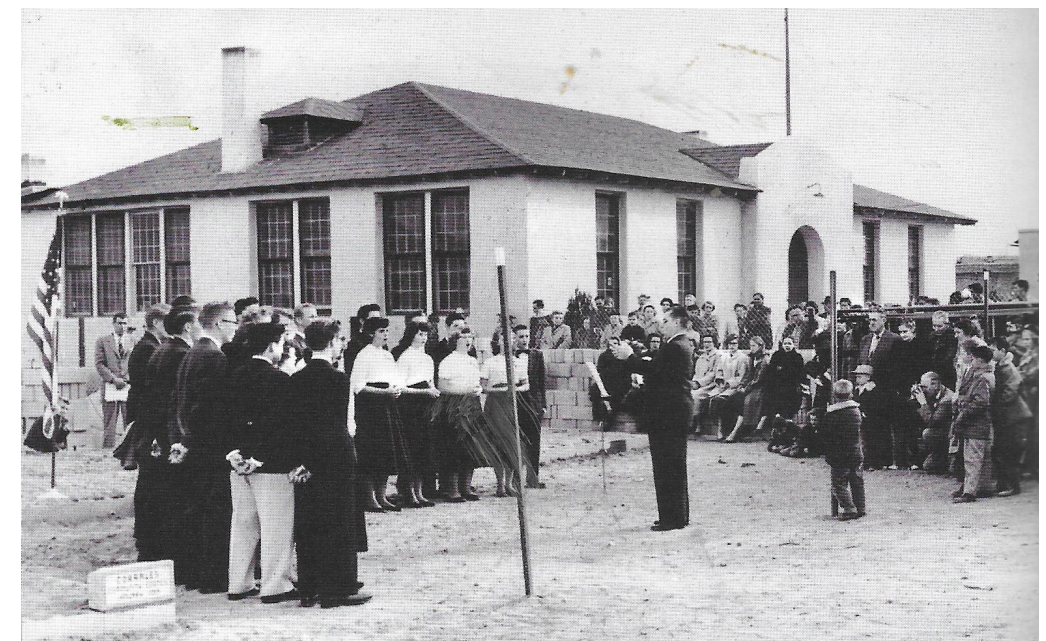
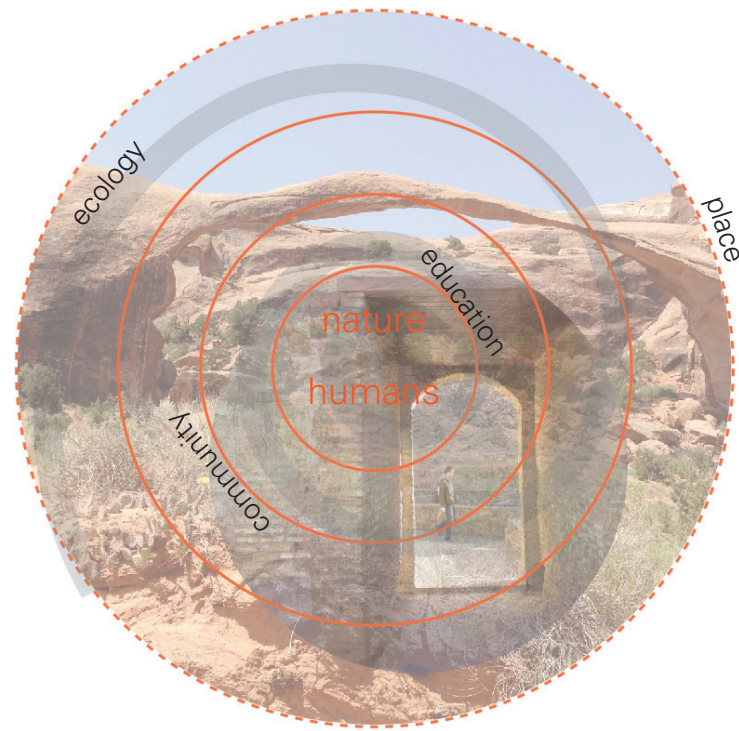

At the turn of the 20th century, Corrales had two schools, one in the northern part of the community and one in the middle. Each of the schools were one room large. A new school was built in 1923, burned down in 1924 and rebuilt in 1925. The school had four rooms, no running water, wood stoves, and outdoor bathrooms (Davis 43). The school taught grades one through eight, and reaching the eighth grade was typically seen as the end of schooling. The school then joined the Albuquerque Public School district in 1956. Instead of building the community up and making it stronger by taking responsibility for the education of its community members, Corrales is sending its students elsewhere and preparing them for a community unlike their own. While the village hopes to maintain its culture and community, the elementary school is established within values of a national and state based public education system. The public education system in the United States has supported a national curriculum which has nurtured a strong “American” identity, but has done so at the expense of a strong connection to the culture, traditions, and natural history of place.

- 33 | holistic approach to education
- 34 | photograph of one of the original schools in Corrales, NM
- 35 | photograph of one of the original schools in Corrales, NM
- 36 | photograph of school built in 1925, Corrales, NM



37 | photograph of Wagner's Farm in Corrales, NM
38 | photograph of harvest festival in Corrales, NM



Climate

USDA Plant Hardiness Zone: 7B
 Sunset Zone: 3a
 AHS Heat Zone: 7-8

Situated at an elevation of 5,023' along the Rio Grande Valley, and only six miles from the Sandia Mountains, Corrales has a diverse landscape that moderates a semi-arid climate. Given the location along the Rio Grande, which supports a canopy of trees, the Village of Corrales tends to be cooler than the surrounding cities of Albuquerque and Rio Rancho. Corrales boasts 280 sunny days with little humidity. What this means is that even though Corrales has a large diurnal range, the temperatures can be easily moderated through the use of shading, thermal mass, and more recently evaporative cooling. There are an average of 81 precipitation days with average annual precipitation reaching around 15" with an average snowfall of 10". The winds tend to shift between the day and night. On average the winds head from the south during the day and reverse at night heading from the north to south. Each season brings new weather patterns to the village.

The Summer tends to be hot during the day reaching up to 100 degrees F, but quickly cools after sunset to the low 70s. During the latter portion of this season, the monsoon hits bringing much needed moisture to the area. The soil tends to be a clay loam and it is often the case that if the soil isn't managed, the rain will quickly turn into flash floods.

The Fall continues the warm weather until around November when the time to break out the sweaters and winter clothing approaches. During this time of year, the air is crisp and the "Harvest Festival" brings the scent of roasted chile to the air.

The Winter brings chances of snowfall, but the sunny days tend to make it quickly disappear. The Sandia Mountains; however, tend to be completely covered in snow throughout the season and this is a time of the year (along with Summer) that the high thermal mass makes a big difference to the thermal comfort of our homes.

Springtime is known for its strong winds, obscuring the mountain range with dust, scattering pollen and seeds, and bringing allergies to our noses. The river starts to thrive again with the freshly melted snow pack and the valley begins to bloom, bringing greenery and life to

Sunny Days | # Precipitation Days | Rain | Elevation

Corrales, NM

Seattle, WA

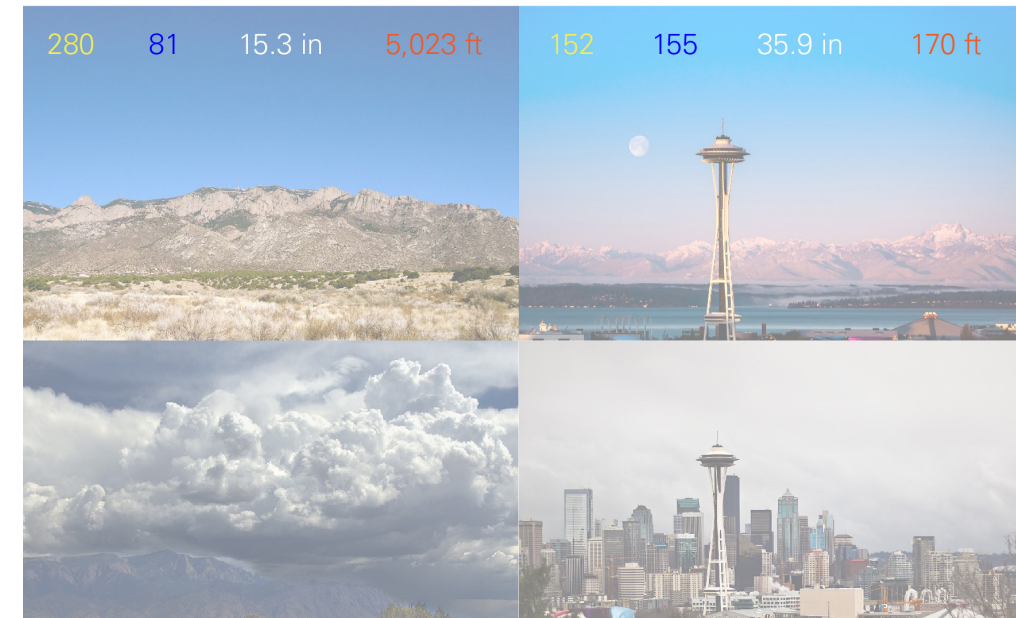

Diurnal Averages

Corrales, NM

Seattle, WA

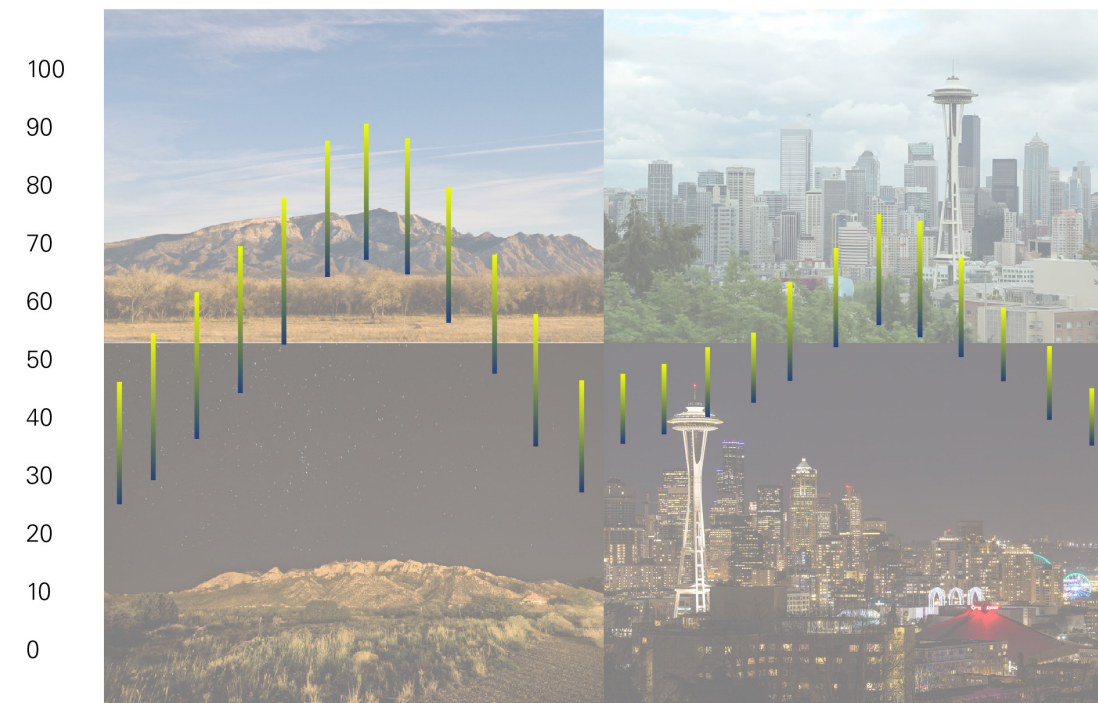

Jan Feb Mar Apr May Jun Jul Aug Sep Oct Nov Dec | Jan Feb Mar Apr May Jun Jul Aug Sep Oct Nov Dec

Natives Americans, and the Spaniards that arrived in the 17th century, evolved a small set of design patterns that employ form, orientation, and high-mass materials to create stable indoor spaces within an environment of extremes. Today, we can see their typical vernacular responses to the climate including the stepped pueblo architecture, creating micro climates and communal spaces, the portal, where a porch is added to create shading from the harsh summer sun and extend the outdoor living quarters, the courtyard, where the structure creates protection from the elements to create a micro climate within the courtyard, as well as the pit house that digs into the earth to provide refuge. These design solutions provide great protection from the elements, and low-tech solutions for people living within this climate.

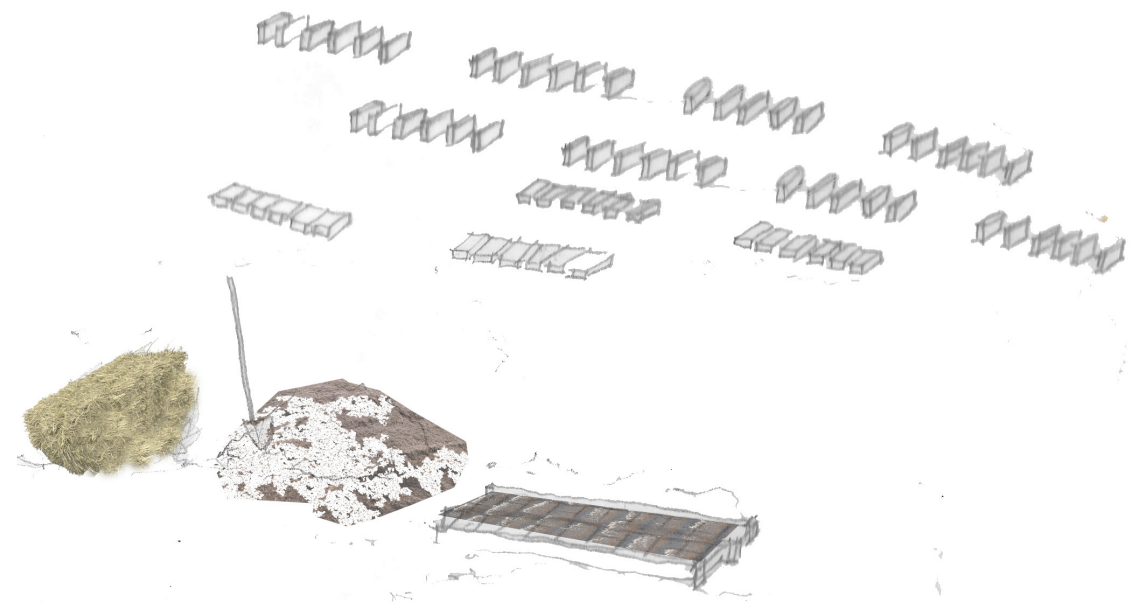
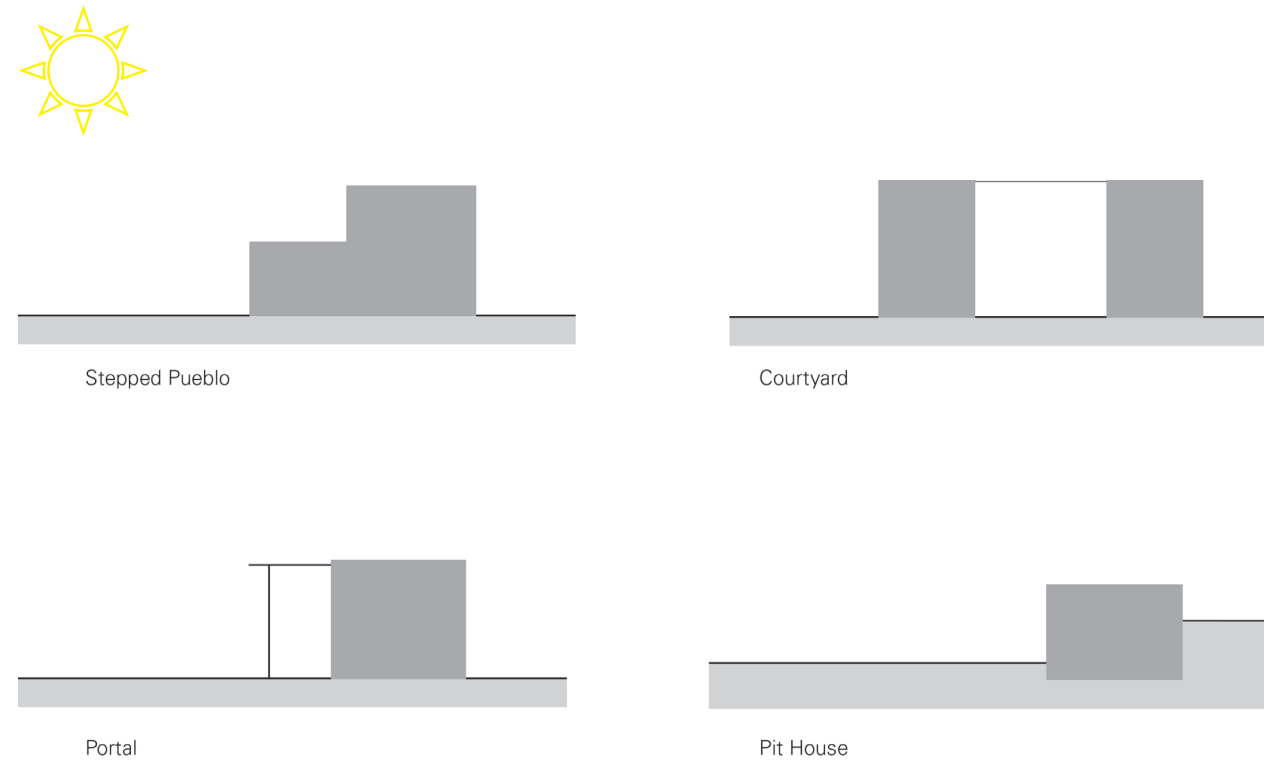
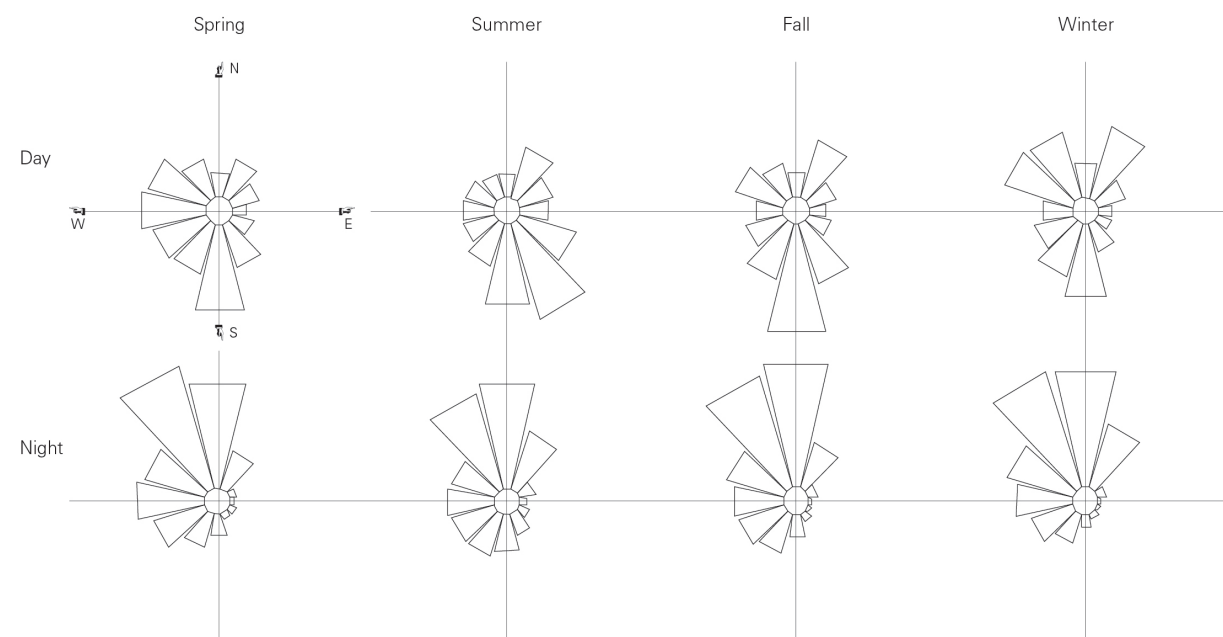
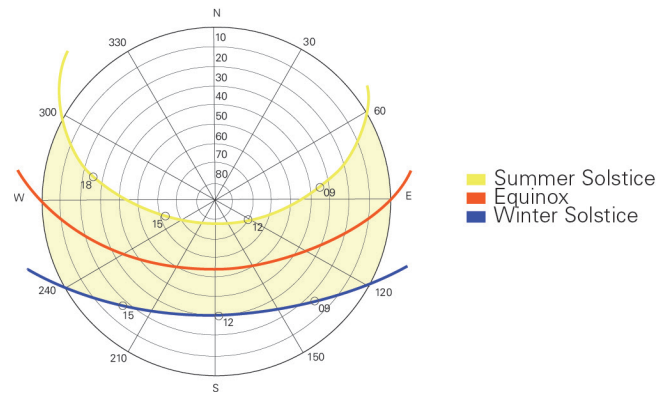

- 41 | Sun diagram of Corrales, NM
- 42 | wind diagram of Corrales, NM
- 43 | vernacular building types of New Mexico
- 44 | process of adobe making

Ecology

Nested at the junction between the southern desert and basin and a bosque ecosystem comprised of riparian forest and floodplains, Corrales is home to more than 500 different species of animals and thousands of native plant species (Wilson). While much of New Mexico used to be covered with native grasses that flourished through succession and wild animal grazing, over the past couple centuries, much of the native grasses have been obliterated due to overgrazing from fenced in and protected livestock. Much of Corrales has been able to keep its rich ecosystem due to the adjacency to the Rio Grande and high water table. The bosque or Spanish for forest, is a haven for many plants and animals. Around the same year that Corrales Elementary School was built, 1950, the U.S. Army Corps of Engineers installed thousands of steel structures intended to trap debris and sediment during floods. As the Village of Corrales grew as well as the demand from Albuquerque, the Rio Grande has been turned into more of a water storage system than a free-flowing river.

The changes to the river and the bosque has drastically changed the systems that relied upon the floods and residual nutrients. One of the key indicator species, the Cottonwood, which has been growing in the area for more than a million years, relies upon the floods to germinate and thus the area has seen a drastic reduction in the Cottonwood canopy and therefore a reduction in the habitat of many plants and animals.

The bosque as well as the number of irrigation ditches provide not only habitat for plants and animals, but places for the meeting and gathering of people. The network of trails and acequias are the recreational hubs of the village, while it is not advised to play in the ditches, these waterways have always been a place for both the young and old to play, socialize, commute, and connect to nature. However, as the ecosystem is becoming more fragile, the experience for us humans becomes less enjoyable. During the fire seasons, the bosque is often off-limits for recreational purposes, and the connection to the water and animals is becoming more disparate. While it may seem that for those that live in the area, there is nothing that can be done to remediate this loss of life, this is not true.

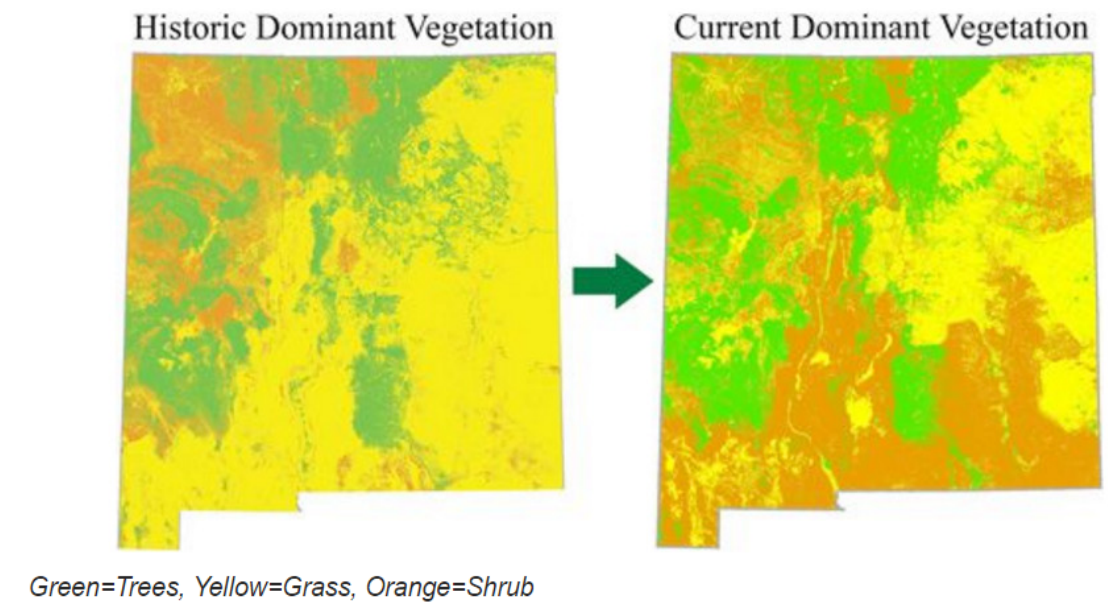

Because living systems are nonlinear and rooted in patterns of relationships, understanding the principles of ecology requires a new way of seeing the world and of thinking—in terms of relationships, connectedness, and context—that goes against the grain of traditional Western science and education...

-Stone, Barlow

There are a number of programs including the Open Space Division, the Bosque Monitoring Program as well as the U.S. Forest Service that are taking initiative to protect and revitalize the ecosystem. Other than supporting these programs, people can start right in their own yard. Through the planting of trees and native grasses supported by the sustainable use of animals and soil remediation, habitat, and therefore emergent properties including endangered animals, would have a place to thrive and bring a dynamic balance to the ecosystem.

By observing the natural processes and relationships between organisms, we can learn how to live a balanced and fruitful life. "Nature demonstrates that sustainable systems are possible. The best of modern science is teaching us to recognize the processes by which these systems maintain themselves. It is up to us to learn to apply these principles and to create systems of education through which coming generations can learn the principles and learn to design societies that honor and complement them" (Stone, Barlow, 29). While the Native peoples of this area have learned throughout generations, we have the aid of technology that can help us more easily understand the connectedness of life. However, there is no better way to understand this than direct experience and exposure to other forms of life.



46 | photograph of flora and fauna of Corrales Elementary
47 | photograph of Rio Grande and bosque
48 | photograph of vegetation left to grow wild

Site

This thesis proposes to reuse the existing public elementary school site to re-imagine the content and context of Corrales Elementary. Bound by Corrales Road to the west and a type of acequia called a lateral drain to the east, Corrales Elementary sits in the heart of the community. The lateral drain was created as a way to prevent the area from flooding given the high water table due to the proximity to the Rio Grande. The lateral drain would relieve some of the excess water and send it back into the Rio Grande at a lower point in the river. To reiterate, Corrales is an oasis in an otherwise harsh environment.

Surrounding the site are single family residences to the north and south and small commercial shops to the west. The lateral drain provides a buffer from more single family residences to the east as well as provides students with a network of irrigation ditches that allow students a safe path to walk and bike to and from school from almost any location within the village. Most of the parcels of land are still contained by long narrow strips of either 1 - 2 acre sites that run perpendicular to the Rio Grande, slightly off the east - west axis.

The elementary school sits on 11 acres with minimal topography. The site is not only used during school hours, but also during community events such as the 4th of July parade and Harvest Festival. Due to the location along Corrales Road and in the center of town, members of the community set up hay bail stops, use the school to set up their 4th of July parade, and hold carnivals during Halloween.

Over the years, I have established a deeply rooted connection to Corrales Elementary. As a toddler, my parents moved about a mile north of the elementary school and built my childhood home. I began my education at Corrales Elementary, starting in kindergarten and graduating in 5th grade. The site currently contains two campuses for learning, but during my education, only the first campus had been built. A set of wood framed buildings with stucco exterior, the original campus was built in the early 1950s. It was only after I left that the school expanded to build another set of buildings, a mixture of wood and steel framing with stucco exterior. The two campuses are split apart with pre-k, 1st, 2nd, and 3rd grades situated in the original campus and kindergarten, 4th, and 5th grades in the new campus. The shared program

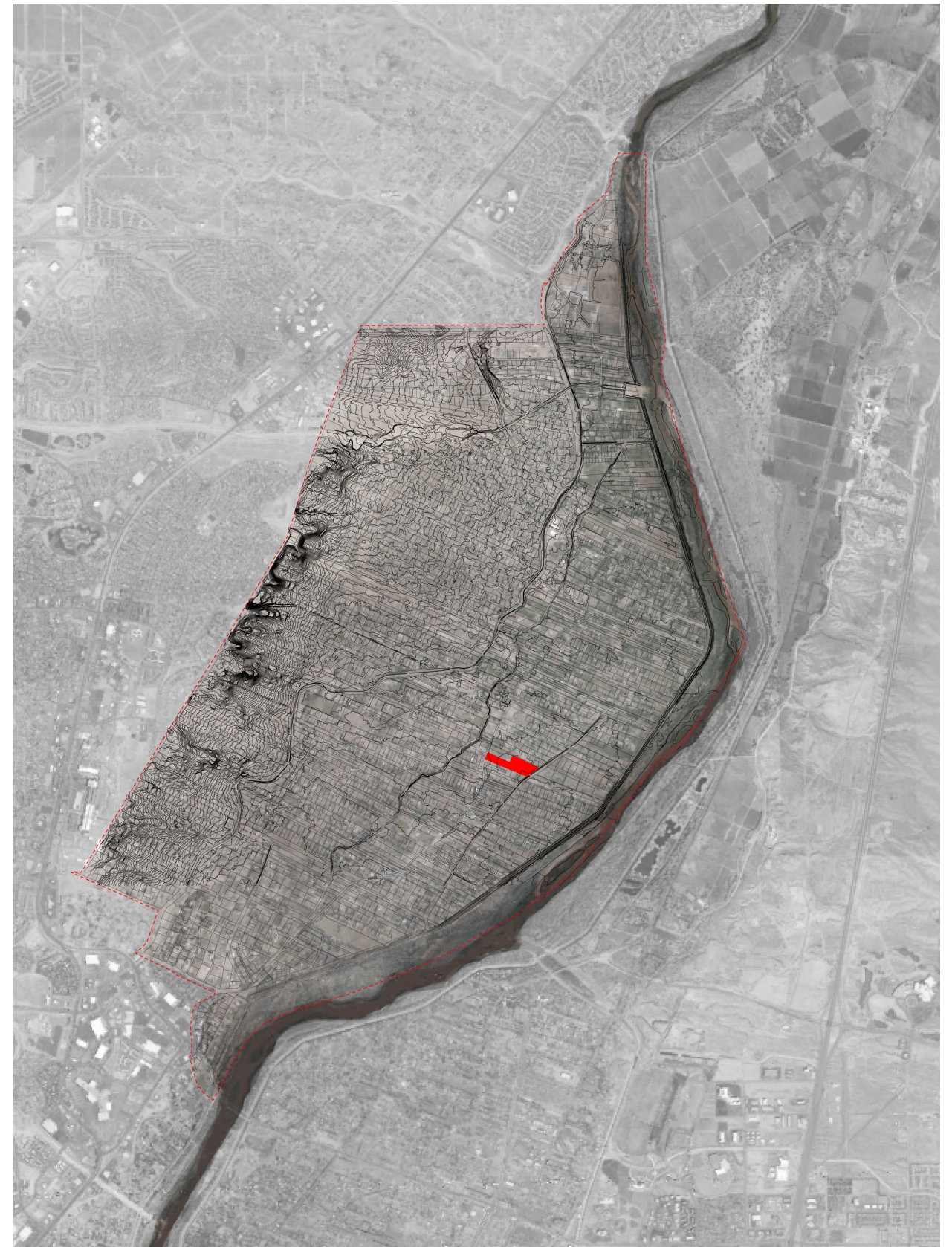

spaces are then split between the two campuses creating a separation between children and their needs.

As a student at Corrales Elementary, the most prevalent memory that comes to mind is impermeable surfaces. Maybe it was the xeriscape mindset (other than the expansive field where we would play kickball), a solution to pave and provide sand that needed little maintenance and water. In contrast, I remember getting out of school, riding the bus and walking home along places that provided xeriscape habitats, but provided a rich assortment of blooming flowers, trees, shrubs, vines and grasses. These environments often provided rooms to play in, places to take a discreet pee on the long walk home, and created habitats to see and interact with wildlife. The elementary school provided ants and not much else.

Besides my own elementary education at Corrales Elementary, I have further ties and experiences getting to know the site. My mom was the counselor there since I was in the second grade up until a few years after I graduated my undergraduate studies. I often visited the campus and even more so when my wife became a fourth grade teacher there and I became an educational assistant to an integrated special needs kindergarten class within the new campus on the east side of the site. I came full circle, from student to teacher within the same environment, but with an entirely new perspective.

What I noticed is a number of problems with the context and content of the elementary school. The old campus is falling apart, it is not designed to take advantage of the site, thus using a lot of energy to maintain comfort. All of the buildings require a large draw upon the energy grid and provide a context that is driven by an industrial model to produce children that can remember facts that prepare them to compete in a global economy, but who do not develop essential social skills, creativity, or sense of place.

According to the New Mexico Public Education Department, during the 2015 school year, the school failed to meet its goals, besides that, my intuition, site research and educational philosophy tells me that neither campus is fulfilling its need to the community. Instead of holding onto the past for the sake of it, I am proposing a reinterpretation of the educational environment and approach to learning that will help provide a place for children to learn and explore life.





Existing school, on the left is the original 1950s school and the addition on the right built in 1999

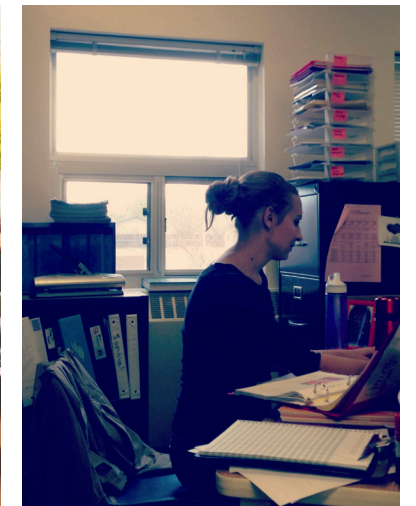

- 51 | aerial view of Corrales Elementary
- 52 | photograph of myself as a student at Corrales Elementary
- 53 | photograph of my mom working as counselor at Corrales Elementary
- 54 | photograph of my wife working as 4th grade teacher at Corrales Elementary
- 55 | photograph of my students as I was their educational assistant at Corrales Elementary
- 56 | photograph of Corrales Elementary signage

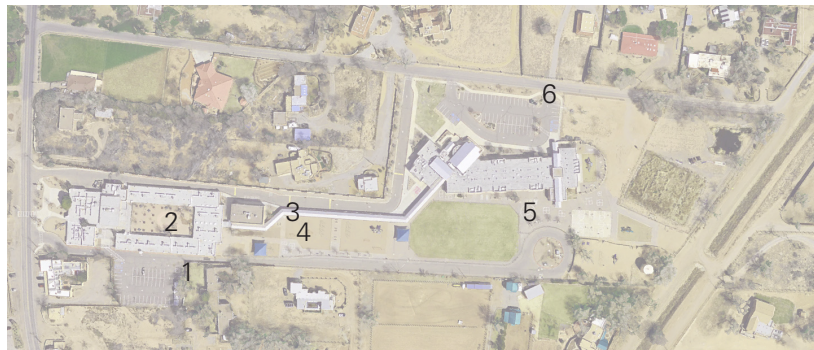

1 looking west



2 looking east



3 looking east



5 looking north



4 looking south



6 looking south



School Grade Report Card
2015
Certified

Final Grade
F *

Corrales Elementary

District: Albuquerque Public Schools
Grade Range: KN - 05 Code: 1351

This School ■
Statewide C Benchmark ■

		Grade	School Points	Possible Points
Current Standing How did students perform in the most recent school year? Students are tested on how well they met targets for their grade level.	■ ■ 21.3	F	9.70	40
School Growth In the past 3 years, did the school as a whole increase performance? For example, did a schoolwide reading program advance reading scores over the prior years?	■ ■ 5.8	F	2.55	10
Student Growth of Highest Performing Students How well did the school help individual students improve? The highest performing students are those whose prior scores placed them in the top three quarters (75%) of their school. Individual student growth over the past 3 years is compared to the state benchmark.	■ ■ 7.2	C	6.63	20
Student Growth of Lowest Performing Students How well did the school help individual students improve? The lowest performing students are those whose prior scores placed them in the bottom quarter (25%) of their school. Individual student growth over the past 3 years is compared to the state benchmark.	■ ■ 15.3	F	3.56	20
Opportunity to Learn Does the school foster an environment that facilitates learning? Are teachers using recognized instructional methods, and do students want to come to school?	■ ■ 7.5	A	9.19	10
Bonus Points Does the school show exceptional aptitude for involving students and parents in education, reducing truancy, and promoting extracurricular activities?	■ ■ 1.6		3.71	5

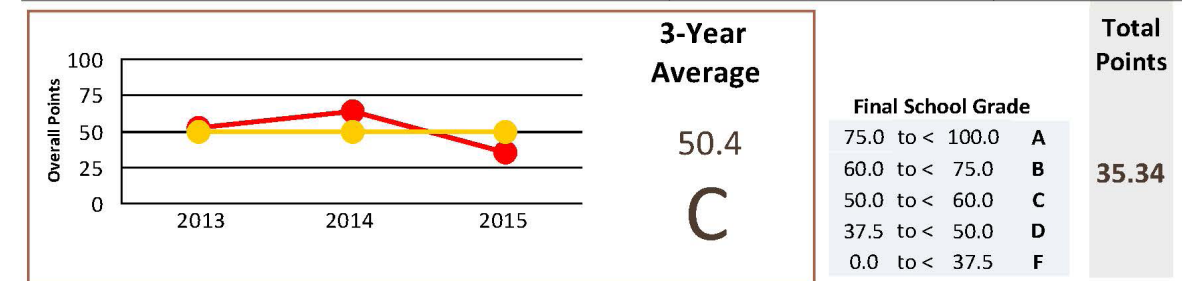

**This school's grade was reduced by one letter because it failed to test 95% of eligible students.



With such a rich history in agriculture, Corrales aims to maintain their rural agricultural roots. The community has made the conscious effort to preserve open land and create a land use code that preserves the community from rapid development. Given the environmental pressures we face today, and a resurgence of locally sourced food and products, the redesigned school aims to provide the context and content that students will flourish within to grasp an understanding of living systems and their place within a broader and rapidly developing world.

To do this, students need a diverse environment to explore a curriculum that is rooted in Ecoliteracy and place. Providing a conceptual guidance for the design as well as guidance for the curriculum, the school is broken into four groups that take lessons from biomimicry and are described in terms of the development of a plant. The groups are subdivided as Seeds, Roots, Stems, and Fruit. The seeds are the shared program spaces for the school including the administration, library, etc., the roots are comprised of pre-k through 1st grade, stems as 2nd and 3rd, and fruits as 4th and 5th.

As a basis for these groups is a study into the developmental stages from Jean Piaget. His observations of children concluded that they were no less intelligent than their adult counterparts, but rather they think differently, and furthermore, children have an active part in their own development. Similar to ideas of experiential education and Reggio Emilia, children should have an invested interest and ability to discover things for themselves. Piaget identified four stages for development including:

The sensorimotor stage, from birth to age 2

The preoperational stage, from age 2 to about age 7

The concrete operational stage, from age 7 to about age 11

The formal operational stage, which begins in adolescence and spans into adulthood

As the school will not have a focus in children from birth to age 2, the concepts for this stage will not be emphasized in the design. A further look into these stages and their key characteristics will be discussed later in the design.

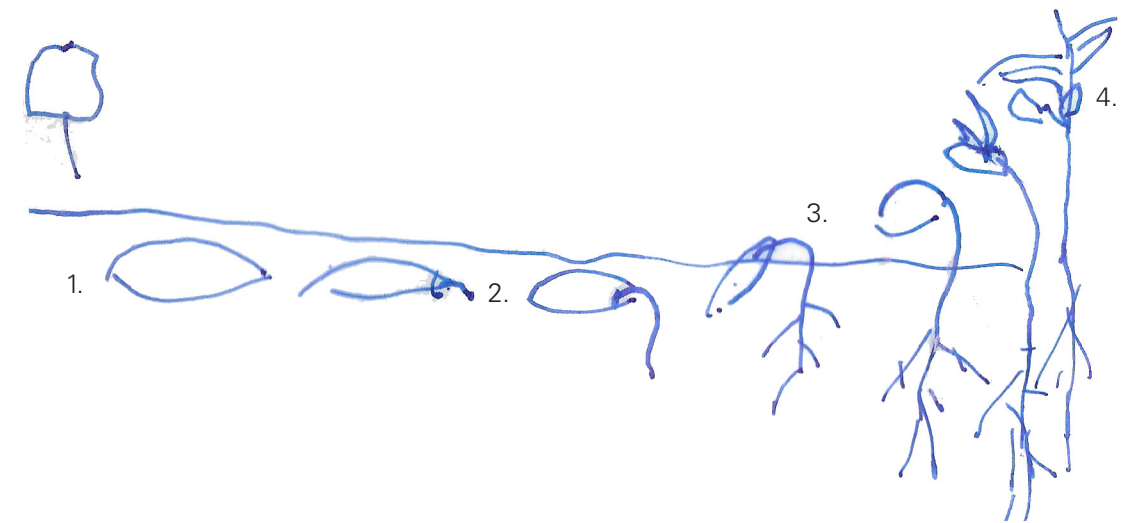

Development of a plant

1. Seeding 2. Rooting 3. Stemming 4. Fruiting

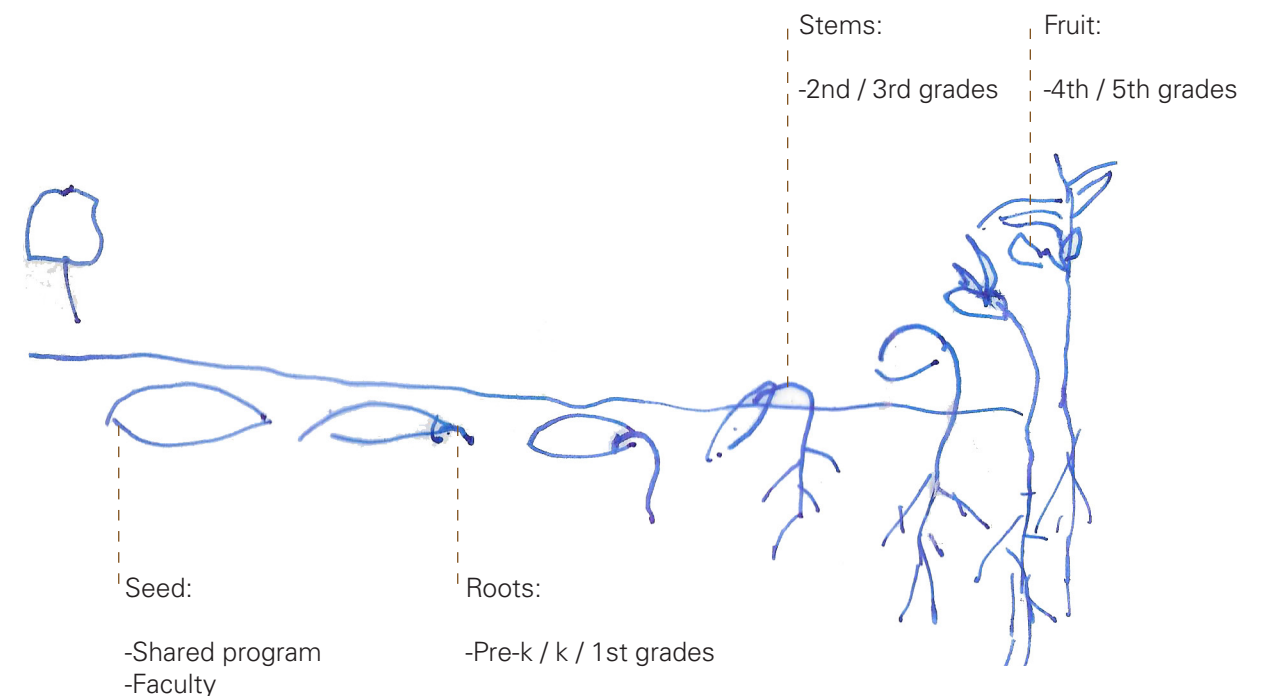

Using Piaget's psychological development as a foundation to group these ages in distinct architectural settings makes sense since they require different needs as they are developing socially, cognitively, and physically which requires difference within their environment as well as within their curriculum. Creating smaller groups rather than a traditional k-5 model creates a greater sense of community and shared experience.

Conceptually, the Seed, or shared program spaces, falls East of the major jog in the site allowing for a central role and easy access to parent pick-up/drop-off for the younger students. From here, the roots and stem project out naturally, creating places within their environment for exploration. The roots extend out towards the source of water, while the stem extends south towards the sun, allowing the fruit to project toward the civic center. While each of the groups can benefit from environments suited to their needs, there are program elements that can be shared to bring the whole community together.

Architecturally, the groups are given environments to support their developmental needs and curricular goals. At the heart of the school, the seed becomes a courtyard or plaza, connecting all of the needs and groups together. The roots are given the pit house which furthers their learning of soil and water, providing refuge and an environment for playing. The stems have the stepped pueblo where the height and indoor/outdoor relationship allows them to survey the area and notice weather patterns and energy flows. And the fruit is given the portal style of architecture where the porch becomes their center of learning, furthering their development of whole systems and their relationship to the community.

The design for the elementary school is informed by the permaculture principles that ethically questions whether our designs are first, good for the earth, second, good for people, and third, considers deficiencies and abundancies and how we can create a balanced environment. Permaculture design aims to create closed looped systems where the needs and resources are kept on site to conserve, regenerate and steward the source of our sustenance and good lives.

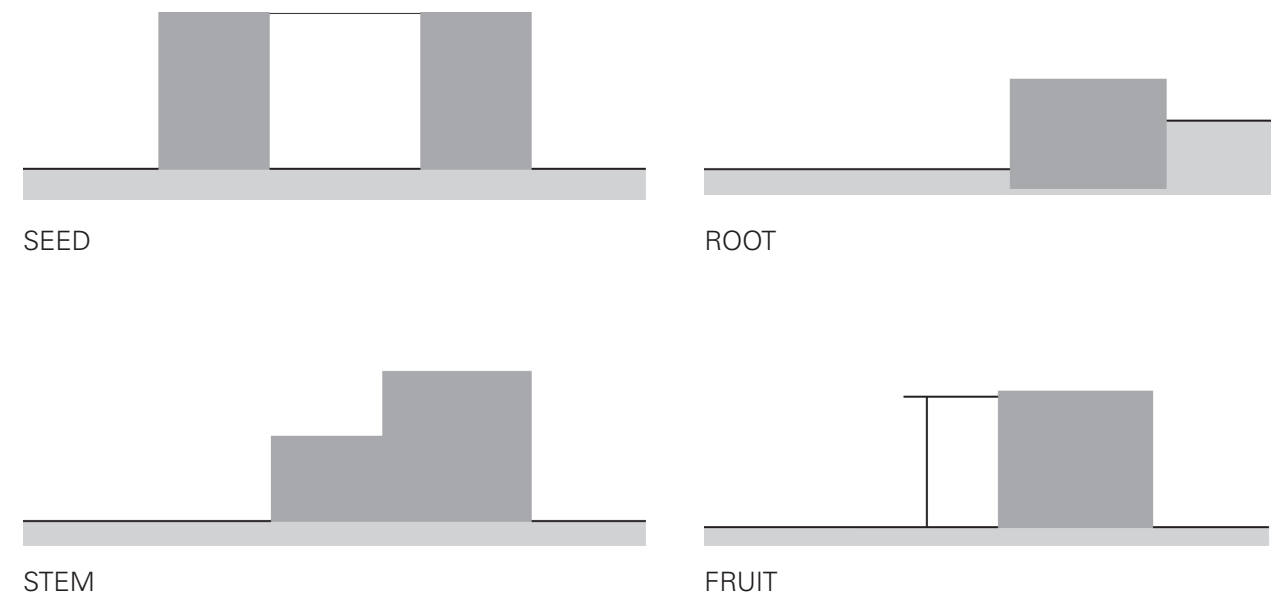
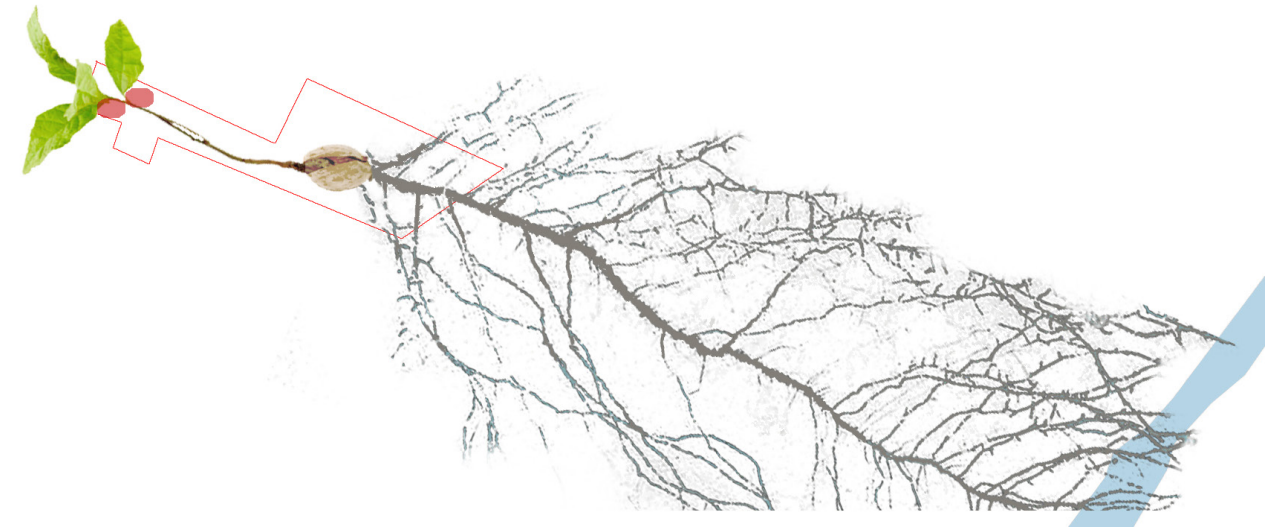

Design

Architecturally, the problem is to define and embody spaces that inspire, aid in comfortable and experiential learning environments, and be a place for community. This thesis explored the redefinition of what an elementary education might look like if it were designed around the idea to foster children who will: be stewards of nature, become problem solvers and question askers, and become fluent in the language of their place. This type of environment will provide a place for learning that will foster children who are better equipped for the uncertain future. Experience is telling mankind that it is vital to reclaim an understanding of the natural world, but in order to do so requires ethics and compassion which are being underdeveloped in the developing world. The school site and architecture were aimed at pointing to the human condition and individual identity to allow children to grasp a larger understanding of place, community, and ecosystems. The school, as a built environment, acts as a context for the exploration of these ideas.

The theoretical framework studied the problems our education system currently face as well as the methods for remediating these problems including children's desire to affiliate with other forms of life, Piaget's developmental stages, experiential education, Eco-literacy, and permaculture started to inform a matrix for design. This matrix then is a tool which informs the type of spaces children need and the type of environment that would foster life-long learners. This part of the framework can then be applied to any location as a basis for holistic design. The architecture then receives further refinement through the careful attention and observation of place. These include, but aren't limited to the culture and community, the climate, and the ecology. Taken as a whole, the matrix then informs a careful process for design.

A careful process for design isn't a fast solution. As the design takes whole systems into account and the effects that the design will have on those systems, including the community, this process takes time to implement. Ideally the community would be involved early and throughout the entire design, construction and commissioning and the project would likely be phased to reach "completion". What should be noted is that this framework is a process and the

All of this is a great forest. Inside the forest is the child. The forest is beautiful, fascinating, green, and full of hopes; there are no paths. Although it isn't easy, we have to make our own paths, as teachers and children and families, in the forest. Sometimes we find ourselves together within the forest, sometimes we may get lost from each other, sometimes we'll greet each other from far away across the forest; but it's living together in this forest that is important. And this living together is not easy.

We have to find each other in the forest and begin to discuss what the education of the child actually means. The important aspect is not just to promote the education of the child but the health and happiness of the child as well.

We need to think of the school as a living organism. Children have to feel that the world is inside the school and moves and thinks and works and reflects on everything that goes on. Of course not all children are the same—each child brings a part of something that's different into the school.

-Loris Malaguzzi

Permaculture-Based Design Pedagogy

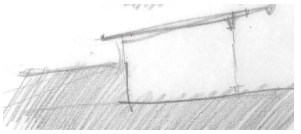
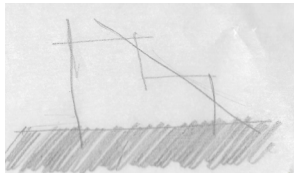
	PERSON			EDUCATION		DESIGN	
	SOCIAL DEVELOPMENT	COGNITIVE DEVELOPMENT	PHYSICAL DEVELOPMENT	PEDAGOGY: EXPERIENTIAL	CURRICULUM: ECO-LITERACY	TPOLOGY INFLUENCE	SOCIAL SPACE
SEED	<p>very social</p> <ul style="list-style-type: none"> -mixed-use stages for self expression, social play, and team work 	<p>mixed</p> <ul style="list-style-type: none"> -perception with all the senses, concept development, language and literacy 	<p>mixed</p>	<p>mixed</p>	<p>mixed</p>	<p>courtyard</p> 	<p>-center of community life</p>
ROOT	<p>inter-classroom</p> <ul style="list-style-type: none"> -ability to play with diverse groups -imaginative play 	<p>Pre-Operational</p> <ul style="list-style-type: none"> -language development, playing and pretending, ego-centric perspectives 	<p>-fine motor</p> <p>-gross motor: hop, skip, jump</p> <p>-skills development</p>	<p>doing</p>	<p>-soil</p> <p>-water</p>	<p>pit-house</p> 	<p>-mix of refuge spaces and open spaces</p> <p>-story telling</p> <p>-dancing</p> <p>-singing</p>
STEM	<p>small group</p> <ul style="list-style-type: none"> -friendships become closer and groups are forming 	<p>Concrete Operational</p> <ul style="list-style-type: none"> -more logical, but struggle with the abstract -experiences to principles -can imagine different scenarios 	<p>-improved hand/eye coordination, overall skills</p>	<p>-critical analysis</p> <p>-reflecting</p>	<p>-forces</p> <p>-wind</p> <p>-sun</p> <p>-animals</p>	<p>pueblo</p> 	<p>-semi-open</p> <p>-overlapping spaces</p> <p>-many families</p>
FRUIT	<p>team focus</p> <ul style="list-style-type: none"> -greater amount of self-direction and leadership forming -understanding other's perspectives -enhanced overall social skills 	<p>Formal Operational</p> <ul style="list-style-type: none"> -abstract ideas and theories applied to creative solutions to problems -hypothesis testing 	<p>-puberty</p> <p>-hand/foot dominance</p> <p>-greater ability to use tools</p>	<p>-synthesis</p> <p>-application</p>	<p>-systems</p> <p>-development</p> <p>-balance</p>	<p>portal</p> 	<p>-gather</p> <p>-extended living</p> <p>-transition between "controlled and uncontrolled wild"</p>

The site's particular attributes including a long narrow strip of land with many angles and jogs, as well as little slope, required many quick as well as hard lined trials of site layout and planning. To remediate the existing school's configuration that provided two campuses that had no relationship to each other, the design turned to a more concentrated school layout so that the students would be close to each other as well as their needs. This layout further allowed the buildings to provide micro climates in the exterior spaces which would help to extend the time the children could spend outdoors in connection to nature as well as help to extend the growing seasons of plants that are close to the high thermal mass, moderating temperature swings.

The appropriate location for the layout of the new school design given the need for a more condensed configuration of program spaces was in the middle of the largest swath of land which allowed the shared program elements to become the center of the school with the classrooms and learning environments arrayed around. What this approach to site designed allowed were both interior and exterior environments suited to the developmental needs of each group of students. Furthermore, this design allowed for an agricultural connection, via the narrow swath of land, to the community which includes large and small intensive growing plots, animal husbandry, and a plaza to celebrate the farmer's market, one of the cornerstones of Corrales' community and culture. This connection to the community allows the students and community members to interact, share wisdom, and work together to provide educational opportunities such as implementing a CSA program and re-skilling workshops.

The connection between community and school is not emphasized linearly, but rather as a path which creates an experience moving between the alley cropping of annuals, community gardens, and community learning spaces. This progression allows people to slow down upon entering the educational environment. We are often in a hurry in today's technologically driven societies and if we can slow down to a more natural pace and rhythm, we start to observe the site and the systems within which it is a part.

As the school contains agriculture and animal husbandry, this is a school that will be used year-round. While the school may not be "in session" throughout the year, a grounds-keeper lives on site to help with maintenance and security. It is hoped that with the investment from the community, further help would not be a problem and events on site could garner interest in preserving, renewing, and stewarding the site.

Conceptual Story

My name is Carlos Gonzalez. My mom tells me our ancestors have lived in Corrales for over three hundred years! I am starting my third year as a Root, the classrooms that are furthest East, towards the mountains. Oh and I have a sister named Danielle, she is in the fruit group and my best friend is Thomas he is in the stems group. The classrooms, or what we call home bases all share similar characteristics, but are different at the same time too. Like my home base is dug into the earth and we get to open our home base with another group of kids so that we have an extra-large room when we are learning about similar things. When I see Thomas, his home base reaches towards the sky. He is able to perceive weather patterns and says he can feel the energy that the school is harnessing when he's playing on the merry-go-round and tetor-totters, he's a little strange sometimes. And after school I go to see my sister where she is always in the portal with her friends and says she is "testing ideas" and that I can't know of such things. I don't mind however because I get to play in the dirt and water, jump on logs and go through tunnels made out of grass. Oh and did you know that the grass and sticks make really good soil, with the help of those little worms of course! My sister says we make the best soil for her experiments and that working with all of the animals and plants, learning how they create systems and balance is soooo cool, I have no idea what she's talking about.

Some of my favorite people at school have their home bases located in the seed, they are the music teacher, the veterinarian and the cook. The cook takes us up to the greenhouse on the second floor of the seed and shows us the importance of seed saving and he really likes to show us the sundial from up there since it is so easy to read, and I can never remember which day it is so it's a great reminder. Oh and next to the sundial is the school grounds care-taker, she is probably the funniest person in the whole wide world, my dad says it's probably because of all the grapes she grows, but I don't know why grapes would make someone funny.

It seems like my mom and dad are always around too. They have a little pea patch near the plaza and they like to take care of some of the animals over there too. Every Sunday we go to sell some of the extra produce and goat cheese at the farmer's market in the plaza, and about once a week, we go to learn about different things in the community learning spaces that are a part of the pea patch network. My sister is really involved with it since her home base works with members of the community to prepare CSA boxes to community members and restaurants. My sister says that the long strip of agriculture emphasizes the cultural and economic connection to the civic center, she is so wise. Ok, time to go find some worms, bye bye!

Site Plan

- | | | | | | |
|---|-----------------------|---|--------------------|----|---------------------------|
| 1 | SEED (shared program) | 5 | STEMS ENVIRONMENT | 9 | COMMUNITY LEARNING |
| 2 | ROOTS (pre-k - 1st) | 6 | FRUITS (4th - 5th) | 10 | SMALL - LARGE PEA PATCHES |
| 3 | ROOTS ENVIRONMENT | 7 | FRUITS ENVIRONMENT | 11 | PLAZA / GROWER'S MARKET |
| 4 | STEMS (2nd - 3rd) | 8 | SUNDIAL PLAY SPACE | | |



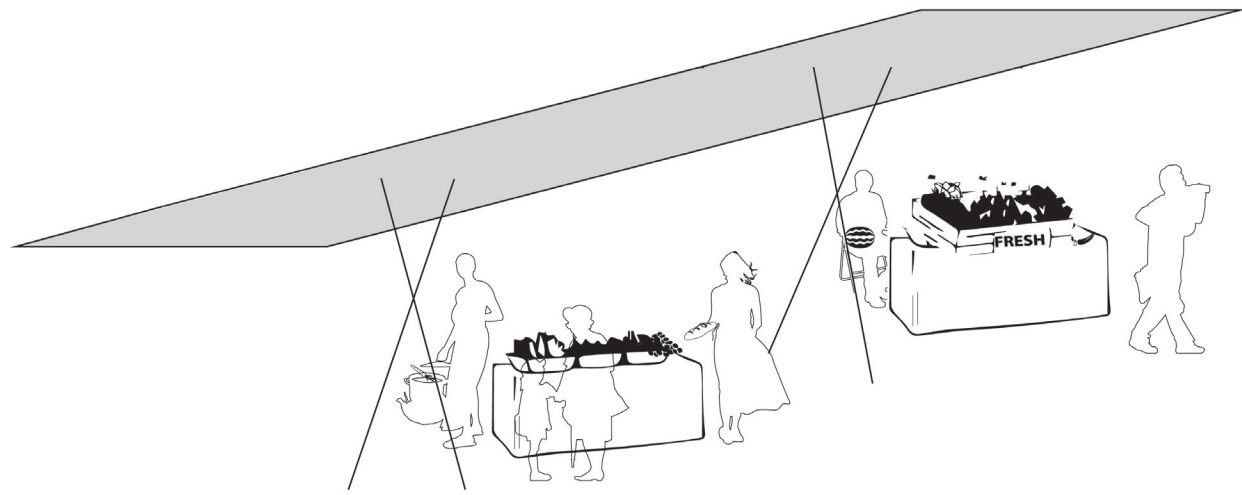

a lightweight canopy creates a flexible-use farmers market and event space

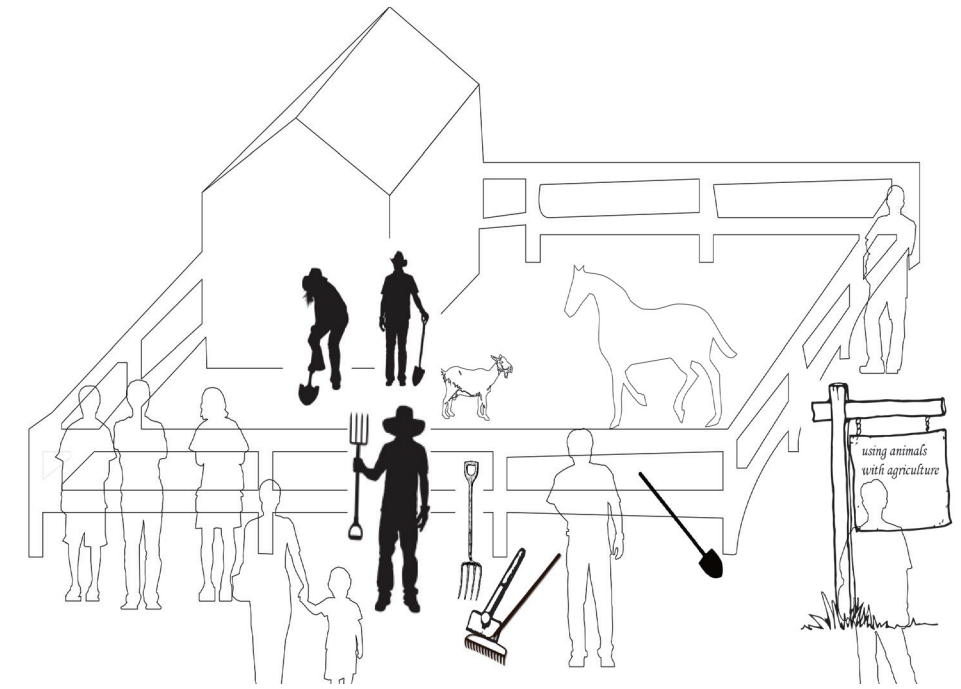

community learning spaces for workshops

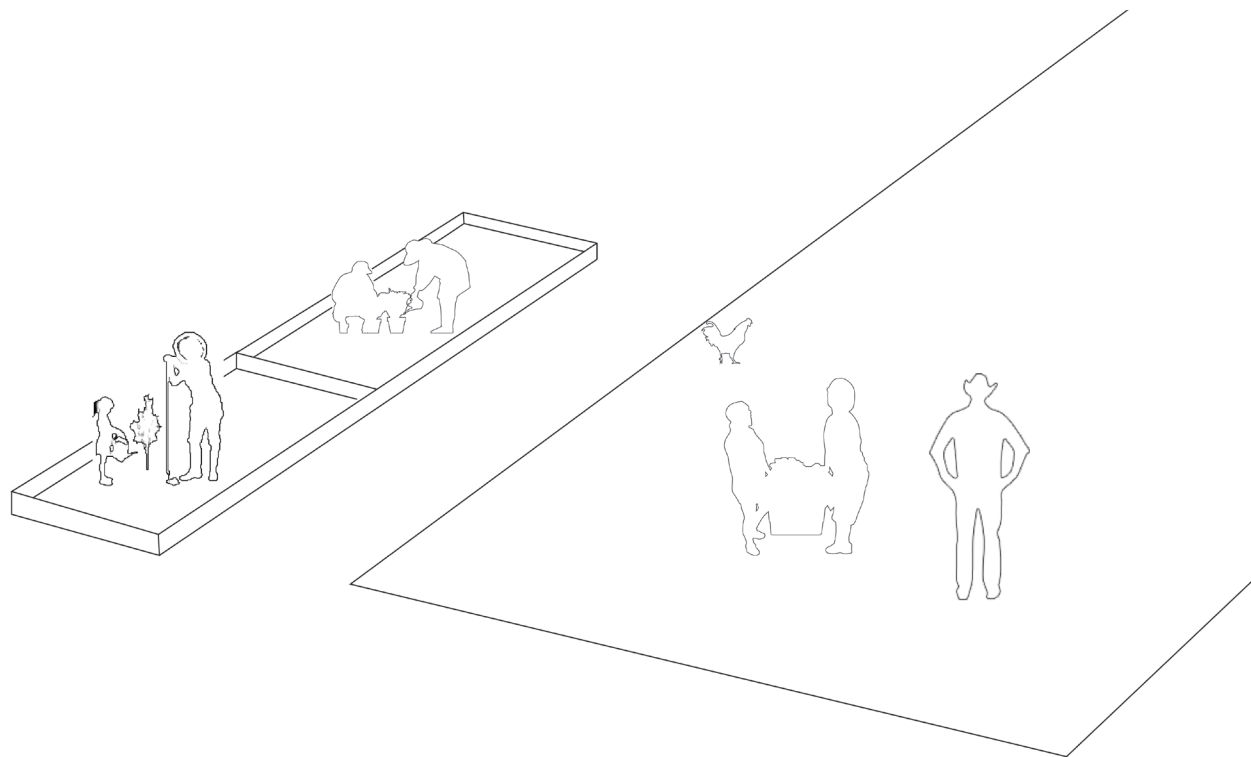

small and large "pea-patches" for community gardening

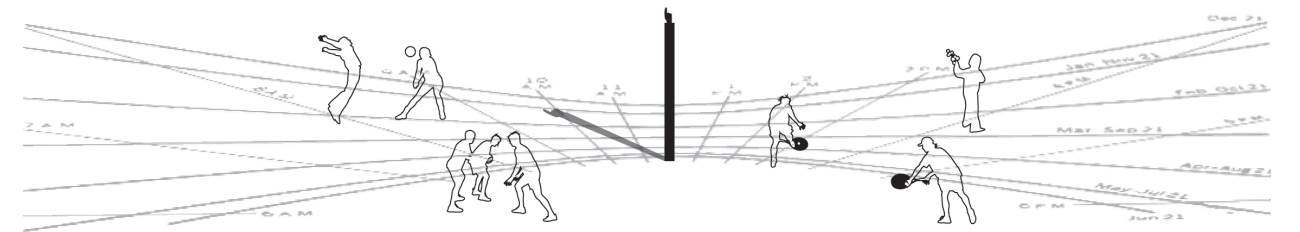

sundial play space to understand time, rhythm, and seasons

Home Base

The interior and exterior environments of each of the program elements including the seed, the root, the stem, and the fruit were developed with the goal to create sensory rich, flexible, thermally comfortable, aesthetically pleasing, and developmentally appropriate environments. The architectural and material response to provide for this type of environment is a cast-in place concrete post and beam system with a thin-shelled vaulted ceiling. This design hits all of the check boxes in the aforementioned goals, and as a basic building block which can be efficiently and cost-effectively administered to any number of environments, the space can then be manipulated to the needs of the students and program. For this site, an appropriate material to infill or partition space are adobe bricks which can be made on-site, provide thermal mass, are a natural material, and aesthetically pleasing.

As mentioned in the conceptual approach to design, each of the developmental groups is given an environment to support their stage of development, their curricular goals, and connect them to place. The architecture and its context displays how each of these criteria are being met.

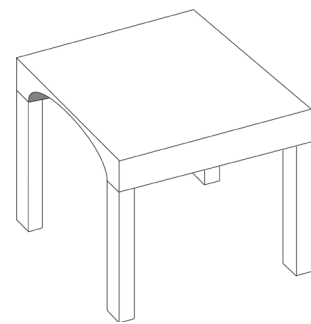

basic building block

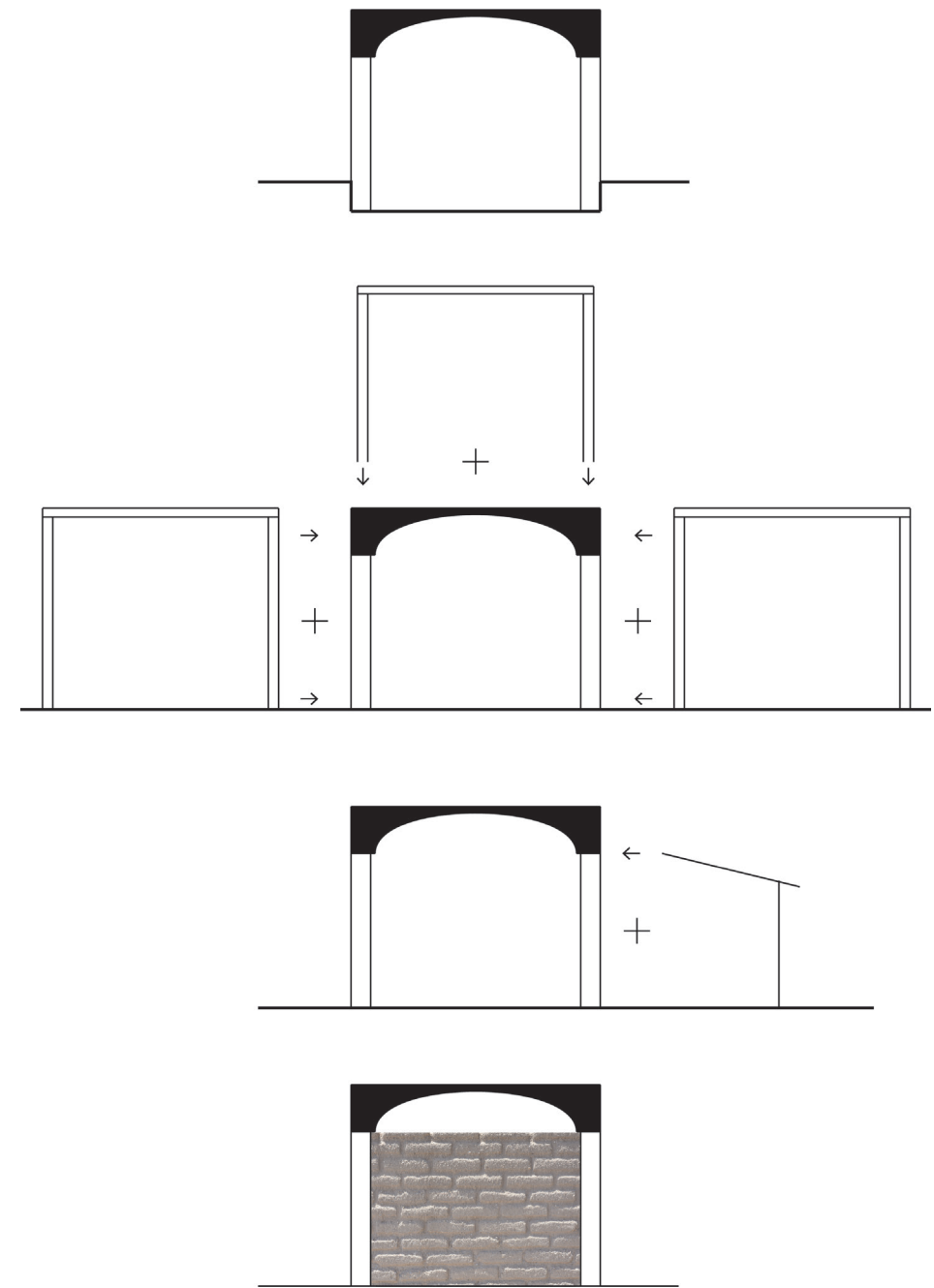

basic building block applied to roots, stems, and fruit - infilled with adobe brick

Seed

PERSON

SOCIAL DEVELOPMENT

very social
-mixed-use stages for self expression, social play, and team work

COGNITIVE DEVELOPMENT

mixed
-perception with all the senses, concept development, language and literacy

PHYSICAL DEVELOPMENT

mixed
-places to practice fine and gross motor development

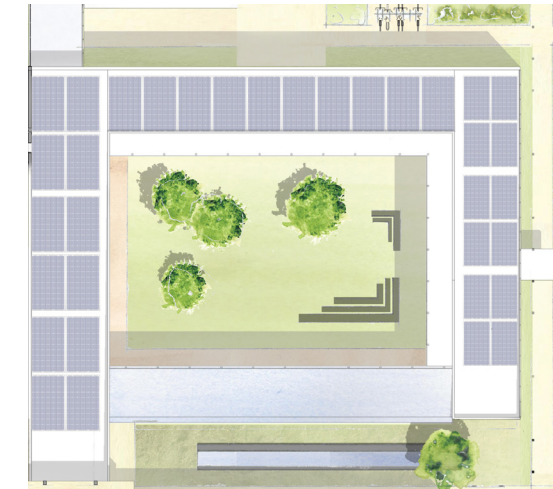

EDUCATION

PEDAGOGY: EXPERIENTIAL

mixed

CURRICULUM: ECO-LITERACY

mixed

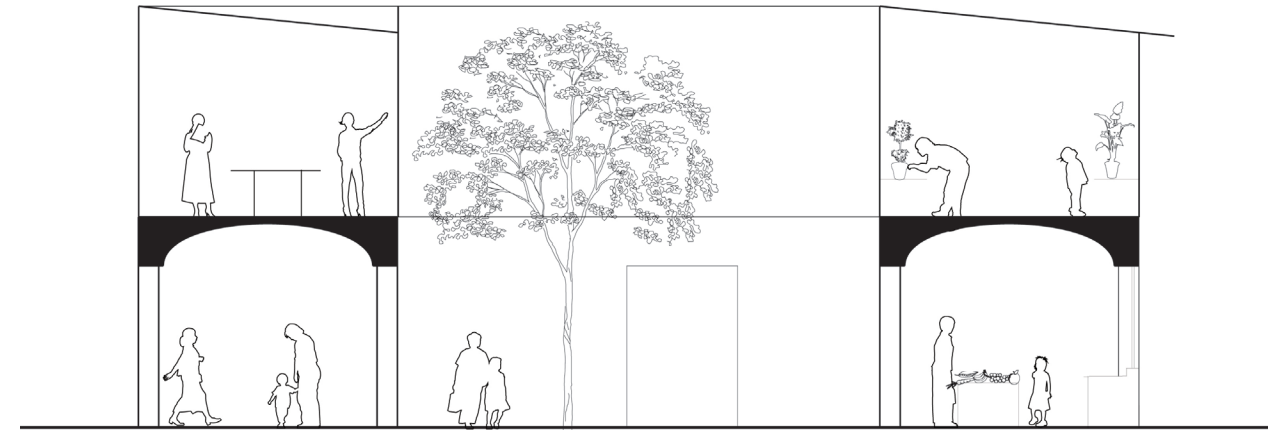

DESIGN

TPOLOGY INFLUENCE

courtyard

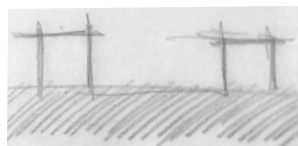

SOCIAL SPACE

center of community life

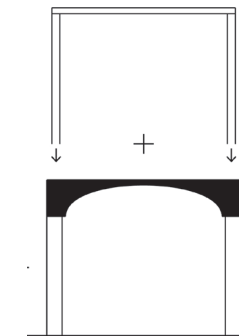

Root

PERSON

SOCIAL DEVELOPMENT

inter-classroom
-ability to play with diverse groups
-imaginative play

COGNITIVE DEVELOPMENT

Pre-Operational
-language development, playing and pretending, ego-centric perspectives

PHYSICAL DEVELOPMENT

-fine motor
-gross motor: hop, skip, jump
-skills development

EDUCATION

PEDAGOGY: EXPERIENTIAL

doing

CURRICULUM: ECO-LITERACY

-soil
-water

DESIGN

TPOLOGY INFLUENCE

pit-house

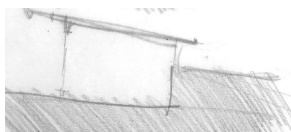

SOCIAL SPACE

-mix of refuge spaces and open spaces
-story telling
-dancing
-singing

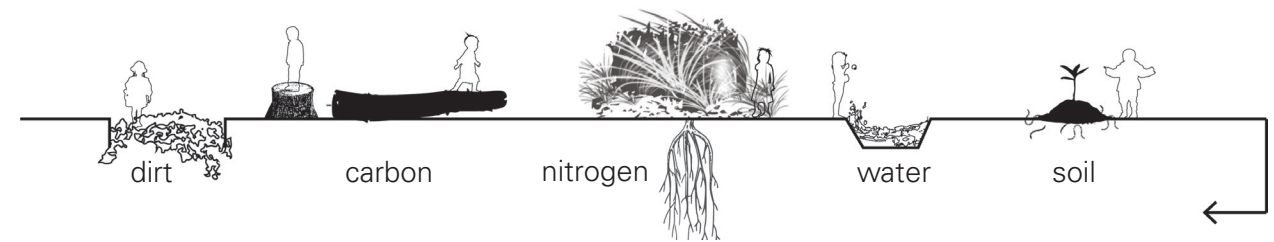
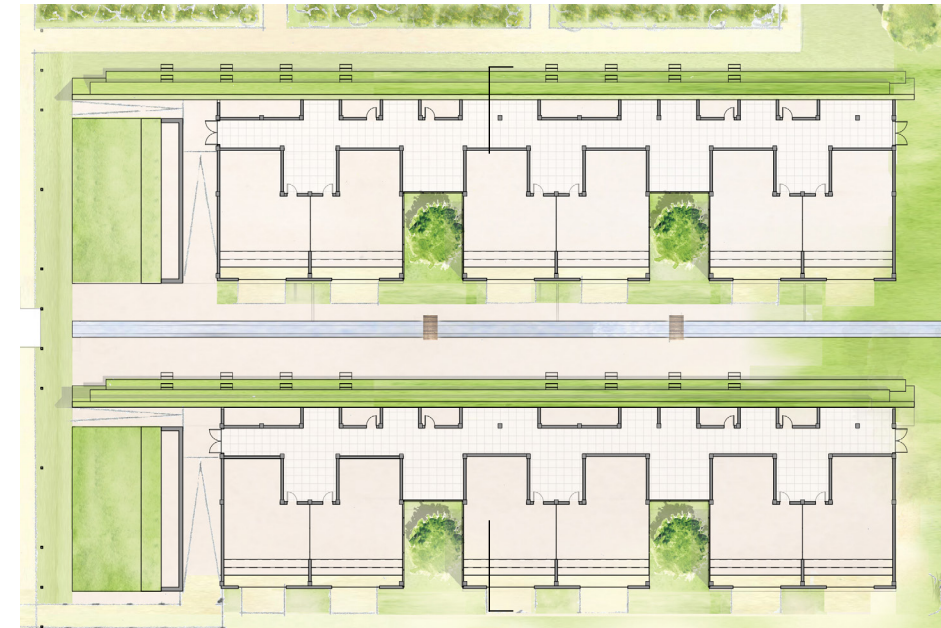



5' 10 20



Stem

PERSON

SOCIAL DEVELOPMENT

small group
-friendships become closer and groups are forming

COGNITIVE DEVELOPMENT

Concrete Operational
-more logical, but struggle with the abstract
-experiences to principles
-can imagine different scenarios

PHYSICAL DEVELOPMENT

-improved hand/eye coordination, overall skills development

EDUCATION

PEDAGOGY: EXPERIENTIAL

-critical analysis
-reflecting

CURRICULUM: ECO-LITERACY

-energy
-wind
-sun
-animals

DESIGN

TPOLOGY INFLUENCE

pueblo

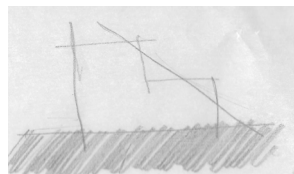

SOCIAL SPACE

-semi-open
-overlapping spaces
-many families

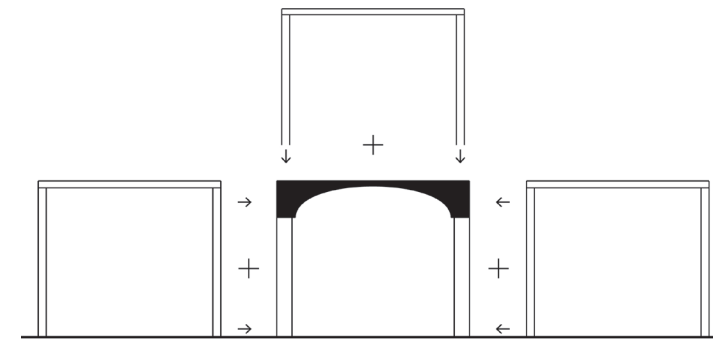
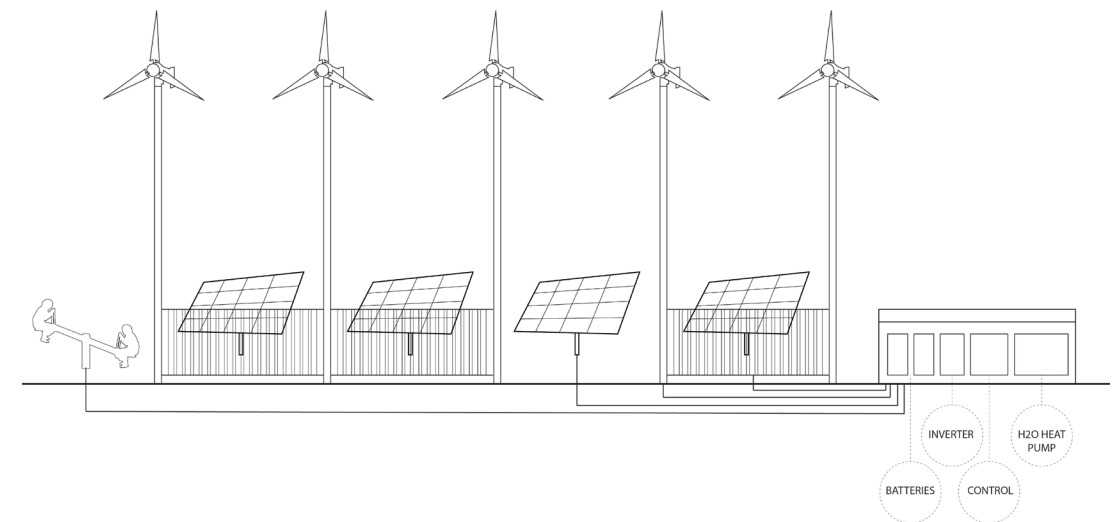

80 | plan of stem's environment

81 | section showing curriculum of harnessing energy

82 | basic building block + pueblo lifted to the sky

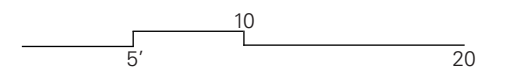



Fruit

PERSON

SOCIAL DEVELOPMENT

team focus
 -greater amount of self-direction and leadership forming,
 -understanding others perspectives
 -enhanced overall social skills

COGNITIVE DEVELOPMENT

Formal Operational
 -abstract ideas and theories applied to creative solutions to problems
 -hypothesis testing

PHYSICAL DEVELOPMENT

-puberty
 -hand/foot dominance
 -greater ability to use tools

EDUCATION

PEDAGOGY: EXPERIENTIAL

-synthesis
 -application

CURRICULUM: ECO-LITERACY

-systems development
 -balance

DESIGN

TYOLOGY INFLUENCE

portal

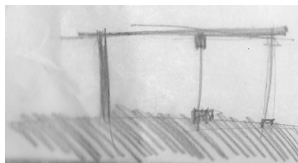

SOCIAL SPACE

-gather
 -extended living
 -transition between "controlled and uncontrolled wild"

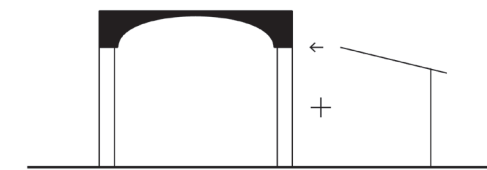
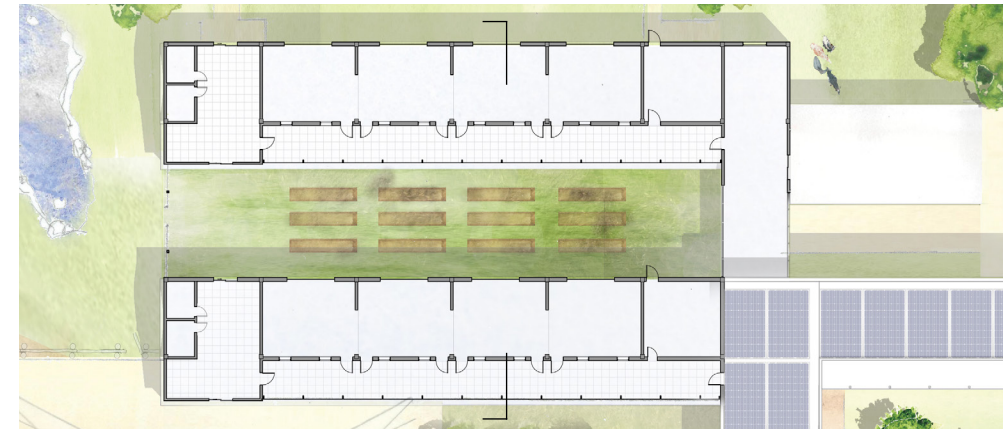

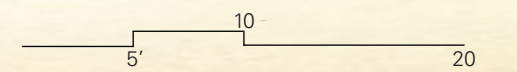



Conclusions

This thesis explored a framework for design which creates a holistic process for the careful planning and design of elementary education that is suited to place. If we as communities don't value our children's rights to have an education that supports their desire: to connect with living things, explore, question and come to their own conclusions, to be supported in their developmental endeavors, and learn in a comfortable and aesthetically pleasing environment, then the hope that they will become life-long learners and stewards of nature is slim. It is not simply an ethical argument that we should all take care of the earth and each other, it is a global necessity. Without a change in our societal values, our connection to nature and ourselves will keep getting more artificial. Nature, in all her wisdom, may choose to kick us off the planet we call home.

One of the permaculture principles is "use small and slow solutions," this principle speaks to the fact that nature takes time to adjust to our designs through the constant feedback of systems. Through the process and practice, we can learn what works in a given place to create regenerative design, thus speeding up this process to ameliorate environments. This should be done; however, only through time tested solutions to local problems. The conceptual design for Corrales Elementary provides the community with a place for their children to learn and explore, a reflection of their culture, and resilience through the many connections both human and not.

To achieve this type of design, the community will have to fulfill their statement of "maintain(ing) a strong agrarian sense of community self-support and community self-determination" (Village of Corrales Comprehensive Land Use Plan). The community may need to decide that the school is part of their jurisdiction and break away from the Albuquerque Public Schools district. While this would not be an easy endeavor, it would be a step in the right direction for the strength of the community. The process then could be applied in phases as the community builds up the soil and creates a space to be shared by all living things to prosper.



Appendix

A little wisdom from one of the great minds of our time speaking of the human condition, education, and nature.

David W. Orr

"Yet we continue to educate the young for the most part as if there were no planetary emergency. It is widely assumed that environmental problems will be solved by technology of one sort or another. Better technology can certainly help, but the crisis is not first and foremost one of technology. Rather, it is a crisis within the minds that develop and use technology."

"For us, coming home means restoring ecological and human scale to a civilization that has lost its sense of proportion and purpose. It means regenerating roots in particular places and traditions. But if we do not build a worthy home, what are we building? And if we do not prepare our young people to come home, for what destination and for what destiny do we consign them?"

"THE RECOVERY OF CHILDHOOD: I began by describing biophilia as a choice. In fact it is a series of choices, the first of which has to do with the conduct of childhood and how the child's imagination is woven into a home place. Practically, the cultivation of biophilia calls for the establishment of more natural places, places of mystery and adventure where children can roam, explore, and imagine...It means redesigning schools and campuses to replicate natural systems and functions. It means greater contact with nature during the school day but also unsupervised hours to play in places where nature has been protected or allowed to recover"

"A constituency able and willing to fight for the long-term human prospect must be educated into existence."

"This leads me to propose that agriculture should be included as a part of a complete liberal arts education, first because it offers an important kind of experience no longer available to many young people from predominantly urban areas. Student responsibility for farm operations would teach the values of discipline, physical stamina, frugality, self-reliance, practical competence, hard work, cooperation, and ecological competence."

"Until quite recently much of what people knew about the natural world they learned from the experience of growing up on a farm or by periodic visits to nearby farms. For all of their flaws, farms were schools of a sort in natural history, ecology, soils, seasons, wildlife, animal husbandry, and land use. The decline of ecologically diverse farms and part, I think, the increasing gap between the broad support for environmental causes evident in public opinion polls and a growing ignorance of how ecosystems work and how private consumption and economic growth destroy the environment."

"Ecological education...requires breaking free of old pedagogical assumptions, of the straitjacket of discipline-centric curriculum, and even of confinement in classrooms and school buildings. Ecological education means changing (a) the substance and process of education contained in curriculum, (b) how educational institutions work, (c) the architecture within which education occurs, and most important, (d) the purposes of learning."

"It is time, I believe, for an educational 'perestroika,' by which I mean a general rethinking of the process and substance of education at all levels, beginning with the admission that much of what has gone wrong with the world is the result of education that alienates us from life in the name of human domination, fragments instead of unifies, overemphasizes success and careers, and unleashes on the world minds ignorant of their own ignorance."

"First, the process of design and construction is an opportunity for a community to deliberate over the ideas and ideals it wishes to express and how these are rendered into architectural form. What do we want our buildings to say about us? What will they say about our ecological prospects? To what large issues and causes do they direct our attention? What problems do they resolve? What kind of human relationships do they encourage?"

"The problem is not just that many academic buildings are unsightly, do not work very well, or do not fit their place or region. The deeper problem is that academic buildings are not neutral, aseptic factors in the learning process. We have assumed, wrongly I think, that learning takes place in buildings, but that none occurs as a result of how they are designed or by whom, how they are constructed and from what materials, how they fit their location, and how—and how well—they operate. My point is that academic architecture is a kind of crystallized pedagogy and that buildings have their own hidden curriculum that teaches as effectively as any course taught in them."

"The functions of ecological design institutes are (1) to equip young people with a basic understanding of systems and to develop habits of mind that seek out 'patterns that connect' human and natural systems; (2) to teach young people the analytical skills necessary for thinking accurately about cause and effect; (3) to give students the practical competence necessary to solve local problems; and (4) to teach young people the habit of rolling up their sleeves and getting down to work."

"How can competence in the ecological design arts be taught within the conventional curriculum? There are at least two broad possibilities. The best, but most difficult, approach is to make over entire institutions so that their operations and resource flows (food, energy, water, materials, waste, and investments) become a laboratory for the study of ecological design. There is a strong case for doing this for economic as well as pedagogic reasons."

"It makes far better sense to reshape ourselves to fit a finite planet than to attempt to reshape the planet to fit our infinite wants."

"If our crisis, however, is first and foremost a crisis of mind and perception, as I believe it to be, the time has come for a fundamental reconsideration of how we might encourage what Edith Cobb (1977) has called 'an acute sensory response to the natural world.'"

Works Cited

- Abdelhamid, Aisha. "Canada "Tops Out" Tallest Wood-Frame Building In The World." CleanTechnica. N.p., 10 Oct. 2016. Web. 2 May 2016.
- "About Reggio Emilia." Community School from Here...anywhere. Community School, n.d. Web. 11 Dec. 2016.
- "American Educational History Timeline." American Educational History Timeline. Edmund Sass, 24 Nov. 2016. Web. 12 July 2016.
- Berry, Wendell. Home Economics: Fourteen Essays. San Francisco: North Point, 1987. Print.
- Bloom, Jessi, and Dave Boehnlein. Practical Permaculture for Home Landscapes, Your Community, and the Whole Earth. Portland, OR: Timber, 2015. Print.
- Boyd, W. (1956) *Émile for Today*. The *Émile* of Jean Jaques Rousseau selected, translated and interpreted by William Boyd, London: Heinemann.
- Cherry, Kendra. "The 4 Stages of Cognitive Development in Children." Verywell. N.p., 22 Nov. 2016. Web. 14 Oct. 2016.
- Davis, Mary P. Corrales, New Mexico. N.p.: Arcadia SC, 2010. Print. Images of America Ser.
- "Educational Programming." IslandWood. IslandWood, n.d. Web. 10 Nov. 2016.
- Hester, Randolph T. Design for Ecological Democracy. Cambridge, MA: MIT, 2010. Print.
- Homestead, Bullock's Permaculture. "Home." Bullock's Permaculture Homestead. Bullock's Permaculture Homestead, n.d. Web. 14 Oct. 2016.
- "International Comparisons of Achievement." National Center for Education Statistics. N.p., n.d. Web. 8 June 2016.
- "LEED | U.S. Green Building Council." LEED | U.S. Green Building Council. N.p., n.d. Web. 17 Dec. 2016.
- Louv, Richard. Last Child in the Woods: Saving Our Children from Nature-deficit Disorder. Chapel Hill, NC: Algonquin of Chapel Hill, 2008. Print.
- Malaguzzi, Loris. "Your Image of the Child: Where Teaching Begins." Reggio Emilia, Italy. June 1993. Seminar.
- "Mission." Data and Research. U.S. Department of Education, 20 Oct. 2011. Web. 12 Oct. 2016.
- Orr, David W. Earth in Mind: On Education, Environment, and the Human Prospect. Washington, DC: Island, 2004. Print.
- Rousseau, Jean Jacques. Social Contract & Discourses. New York: E. P. Dutton & Co., 1913; Bartleby.com, 2010. www.bartleby.com/168/. 14 August 2016.
- Stone, Michael K. "APPLYING ECOLOGICAL PRINCIPLES." Center for Ecoliteracy. Center for Ecoliteracy, 25 July 2012. Web. 15 Oct. 2016.
- Stone, Michael K. Smart by Nature: Schooling for Sustainability. Healdsburg, CA: Watershed Media, 2009. Print.
- Strong-Wilson, Teresa, and Julia Ellis. "Children and Place: Reggio Emilia's Environment as Third Teacher." Theory Into Practice 46.1 (2007): 40-47. Web. 24 Sept. 2016.
- Taylor, Anne P., and Katherine Enggass. Linking Architecture and Education: Sustainable Design for Learning Environments. Albuquerque: U of New Mexico, 2009. Print.
- "The Economics of Biophilia." Terrapin Home - Terrapin Bright Green. N.p., 01 May 2014. Web. 5 July 2016.
- "Village of Corrales Comprehensive Land Use Plan." (2009): n. pag. Village of Corrales New Mexico. Village of Corrales. Web. 10 June 2016.
- Wilson, Ruth A. "Beauty of the Bosque - American Forests." American Forests. American Forests, 2012. Web. 13 Dec. 2016.

Bibliography

- Akerlof, George A., and Robert J. Shiller. *Animal Spirits: How Human Psychology Drives the Economy, and Why It Matters for Global Capitalism*. Princeton: Princeton UP, 2009. Print.
- Alexander, Christopher, Sara Ishikawa, and Murray Silverstein. *A Pattern Language: Towns, Buildings, Construction*. New York: Oxford UP, 1977. Print.
- Allen, Jenny, and B. C. Mollison. *Smart Permaculture Design*. Sydney: New Holland, 2002. Print.
- Bejan, Adrian, and J. Peder Zane. *Design in Nature: How the Constructal Law Governs Evolution in Biology, Physics, Technology, and Social Organization*. New York: Doubleday, 2012. Print.
- Benyus, Janine M. *Biomimicry: Innovation Inspired by Nature*. New York: Morrow, 1997. Print.
- Berry, Wendell. *Home Economics: Fourteen Essays*. San Francisco: North Point, 1987. Print.
- Berry, Wendell. *What Are People For?: Essays*. San Francisco: North Point, 1990. Print.
- Bloom, Jessi, and Dave Boehlein. *Practical Permaculture for Home Landscapes, Your Community, and the Whole Earth*. Portland, OR: Timber, 2015. Print.
- Bronfenbrenner, Urie. *The Ecology of Human Development: Experiments by Nature and Design*. Cambridge, MA: Harvard UP, 1979. Print.
- Carson, Rachel. *Silent Spring*. 215 Park Avenue South, NY, NY 10003: Houghton Mifflin, 1962. Print.
- Day, Christopher, and Susan Roaf. *Spirit & Place: Healing Our Environment, Healing Environment*. Oxford: Architectural, 2002. Print.
- Downton, Paul F. *Ecopolis: Architecture and Cities for a Changing Climate*. Dordrecht: Springer Science Business Media, 2009. Print.
- Goleman, Daniel, Lisa Bennett, and Zenobia Barlow. *Ecoliterate: How Educators Are Cultivating Emotional, Social, and Ecological Intelligence*. San Francisco, CA: Jossey-Bass, 2012. Print.
- Hester, Randolph T. *Design for Ecological Democracy*. Cambridge, MA: MIT, 2010. Print.
- Hurd, A-P, and Al Hurd. *The Carbon Efficient City*. Seattle: U of Washington, 2012. Print.
- Lengen, Johan Van. *The Barefoot Architect: A Handbook for Green Building*. Bolinas, CA, U.S.A: Shelter Publications, 2008. Print.
- Louv, Richard. *Last Child in the Woods: Saving Our Children from Nature-deficit Disorder*. Chapel Hill, NC: Algonquin of Chapel Hill, 2008. Print.
- Macnamara, Looby, and Rebecca Storch. *People & Permaculture: Caring and Designing for Ourselves, Each Other and the Planet*. East Meon, Hampshire, England: Permanent Publications, 2012. Print. Intro to permaculture
- Nelson, Louis P. *American Sanctuary: Understanding Sacred Spaces*. Bloomington: Indiana UP, 2006. Print.
- Orr, David W. *Earth in Mind: On Education, Environment, and the Human Prospect*. Washington, DC: Island, 2004. Print.
- Ryn, Sim Van Der, and Stuart Cowan. *Ecological Design*. Washington, D.C.: Island, 1996. Print.
- Stone, Michael K. *Smart by Nature: Schooling for Sustainability*. Healdsburg, CA: Watershed Media, 2009. Print.
- Trachtenberg, Marvin, Isabelle Hyman, and Marvin Trachtenberg. *Architecture, from Prehistory to Postmodernity*. New York: Harry N. Abrams, 2002. Print.
- Vitek, William, and Wes Jackson. *The Virtues of Ignorance: Complexity, Sustainability, and the Limits of Knowledge*. Lexington, KY: U of Kentucky, 2008. Print.
- White, Courtney. *Grass, Soil, Hope: A Journey through Carbon Country*. Print.