

**SPATIAL ANALYSIS OF ACCESSIBLE SEATING AREA
ON THE NEXT GENERATION PASSENGER RAIL CARS
USING 3-D MODELING AND DIGITAL HUMAN MODELING**

FINAL PROJECT REPORT

by

Katharine Hunter-Zaworski
Kamolnat Tabattanon
Oregon State University

Sponsorship
PacTrans and Oregon State University

for

Pacific Northwest Transportation Consortium (PacTrans)
USDOT University Transportation Center for Federal Region 10
University of Washington
More Hall 112, Box 352700
Seattle, WA 98195-2700

In cooperation with US Department of Transportation-Research and Innovative
Technology Administration (RITA)



Disclaimer

The contents of this report reflect the views of the authors, who are responsible for the facts and the accuracy of the information presented herein. This document is disseminated under the sponsorship of the U.S. Department of Transportation's University Transportation Centers Program, in the interest of information exchange. The Pacific Northwest Transportation Consortium, the U.S. Government and matching sponsor assume no liability for the contents or use thereof.

Technical Report Documentation Page

1. Report No.	2. Government Accession No.	3. Recipient's Catalog No.	
4. Title and Subtitle Spatial analysis of accessible seating area on the next generation passenger rail cars using 3-D modeling and digital human modeling		5. Report Date August 3, 2018	
		6. Performing Organization Code	
7. Author(s) K.M. Hunter-Zaworski, and K. Tabattanon ORCID: 0000-0001-5042-3667		8. Performing Organization Report No. 2017-S-OSU-4	
9. Performing Organization Name and Address PacTrans Pacific Northwest Transportation Consortium University Transportation Center for Region 10 University of Washington More Hall 112 Seattle, WA 98195-2700		10. Work Unit No. (TRAIS)	
		11. Contract or Grant No. 69A3551747110	
12. Sponsoring Organization Name and Address United States of America Department of Transportation Research and Innovative Technology Administration		13. Type of Report and Period Covered Research Final Report	
		14. Sponsoring Agency Code	
15. Supplementary Notes Report uploaded at www.pacTrans.org			
16. Abstract <p>This project extended research that was conducted for the Federal Railroad Administration (FRA) in collaboration with the Passenger Rail Investment and Improvement Act Next Generation Equipment Committee on the development of specifications for the next generation of passenger rail cars. The FRA research project conducted a preliminary spatial analysis to determine whether two or more wheeled mobility devices (WhMD) could be accommodated in the seating compartment of next generation passenger rail cars. The original project showed that it is possible to accommodate two WhMDs with the loss of one or two revenue seats. However, there was significant concern that occupant protection and containment of WhMDs could be compromised.</p> <p>This research project used 3-D modeling tools and anthropometric digital human models to design and evaluate passenger rail interior layouts for inclusivity and safety while also considering design constraints for vehicle builders and operators. By itself, 3-D modeling provided a means of digitally evaluating the design feasibility of potential accommodations. Including anthropometric human models into the early phases of design then accounted for human and ergonomic factors. The use of digital evaluation permitted the inclusion of analysis for many different types of WhMDs, design scenarios and anthropometric users within the same space.</p> <p>The significant findings illustrated the challenge of both providing space for maneuvering WhMDs and controlling for the loss of revenue seating. The project examined a number of different scenarios for accommodating one or two WhMDs. This project recommends the use of rear-facing seating to provide containment for WhMDs and the use of personal restraint devices such as seat belts to control the amount of free flight associated with severe braking conditions and limit secondary impacts.</p> <p>This project also used a framework for 3-D modeling to evaluate and test spatial consumption, feasibility, human factors, and human-environment interaction, and this framework could be used on other modes of passenger rail travel and transit.</p>			
17. Key Words Wheeled Mobility Devices, Occupant Protection, Containment, revenue seats, Compartmentalization		18. Distribution Statement No restrictions.	
19. Security Classification (of this report) Unclassified.	20. Security Classification (of this page) Unclassified.	21. No. of Pages	22. Price NA

Table of Contents

1	INTRODUCTION	1
	1.1 Background	1
	1.2 Compartmentalization and Containment	2
2	LITERATURE REVIEW	5
3	METHOD	9
	3.1 Overall Approach.....	9
	3.2 Visualization	9
4	RESULTS	11
	4.1 Scenario A Layout	12
	4.2 Scenario B Layout.....	14
	4.3 Scenario C Layout.....	14
	4.4 Scenario D Layout	15
	4.5 Scenario E Layout	16
	4.6 Scenario F Layout	17
	4.7 Scenario G Layout	18
	4.8 Scenario H Layout	19
5	DISCUSSION	21
	5.1 Containment and Compartmentalization	21
	5.2 Challenges	22
6	CONCLUSIONS AND RECOMMENDATIONS	23
7	REFERENCES	25
8	APPENDIX A.....	27
	8.1 Representative Wheeled Mobility Device Dimensions	27
	A.1.1 Manual Wheelchair	27
	A.1.2 Power-Based Wheelchair.....	27

A.1.3 Scooter	28
9 APPENDIX B.....	31
9.1 Technical Specifications for Q'Straint Quantum from Quantum Data Sheet (Q'Straint n.d.).....	31

List of Figures

Figure 2-1	Secondary impact in Stage 3 is responsible for injuries as shown	6
Figure 2-2	Graph of relative displacement associated with occupant free-flight and the relative velocity that is a factor of injury severity.....	7
Figure 4-1	Scenario A without and with a 95th percentile male manikin	13
Figure 4-2	Scenario B, layout with extra position but limited aisle width	14
Figure 4-3	Scenario C, accommodation of two WhMDs.....	15
Figure 4-4	Scenario D, accommodation of two WhMDs on same side of the train	16
Figure 4-5	Scenario E shows accommodation of one or two WhMDs and limited occupant protection.....	17
Figure 4-6	Scenario F showing options for rear-facing accommodation, with restricted seat access.....	18
Figure 4-7	Scenario G showing additional options that would require stabilization of WhMD	19
Figure 4-8	Scenario H for stowage of unoccupied WhMD	19
Figure A- 1	Manual wheelchair turning radius and footprint	27
Figure A- 2	Power base radius and footprint	28
Figure A- 3	Large and medium size scooters radii and footprints.....	29
Figure B 1	Picture of Quantum installed on transit bus (Q'Straint 2017)	32

List of Tables

Table 4-1 Description of scenario layouts.....11

List of Abbreviations

CAD:	Computer-aided design
DHM:	Digital human modeling
FRA:	Federal Railway Administration
PacTrans:	Pacific Northwest Transportation Consortium
WhMD:	Wheeled Mobility Device, including manual wheelchairs, three- and four-wheeled scooters, powered wheeled mobility devices, wheeled walkers, and other wheeled devices.
WSDOT:	Washington State Department of Transportation

Acknowledgments

This report contains work that was funded in part by the National Academies Rail Safety IDEA Project -31, “*Modeling and validation of standards for a sleeper compartment on accessible passenger rail vehicles.*” In addition, the work reported in this document was funded in part by the Federal Railroad Administration, Contract Number DTFR53-17-C-00014, titled “Cost, Safety and Feasibility of Accessible Recommendations: Phase III.”

Executive Summary

This project extended research that was conducted for the Federal Railroad Administration (FRA_ in collaboration with the Passenger Rail Investment and Improvement Act Next Generation Equipment Committee (NGEC) on the development of specifications for the next generation of passenger rail cars. The FRA research project conducted a preliminary spatial analysis to determine whether two or more wheeled mobility devices (WhMD) could be accommodated in the seating compartments of next generation passenger rail cars. The original project showed that it would be possible to accommodate two WhMD with the loss of one or two revenue seats. However, there was significant concern that occupant protection and containment of WhMD might be compromised,

This research project used 3-D modeling tools and anthropometric digital human models to design and evaluate passenger rail interior layouts for inclusivity and safety while also considering design constraints for vehicle builders and operators. By itself, 3-D modeling provided a means of digitally evaluating the design feasibility of potential accommodations. Including anthropometric human models into the early phases of design then accounted for both human ergonomic factors. The use of digital evaluation permitted the inclusion of analysis for many different types of WhMDs, design scenarios, and anthropometric users within the same space.

The significant findings illustrated the challenges of providing space for maneuvering WhMDs and controlling for the loss of revenue seating. The project examined a number of different scenarios for accommodating one or two WhMDs. This project recommends the use of rear-facing seating to provide containment for WhMDs and the use of personal restraint devices

such as seat belts to control the amount of free flight that is associated with severe braking conditions and limit secondary impacts.

This project also used a framework for 3-D modeling to evaluate and test spatial consumption, feasibility, human factors, and human-environment interaction, and that this framework could be used on other modes of passenger rail travel and transit.

1 Introduction

1.1 Background

The Federal Railroad Administration (FRA) and members of the Passenger Rail Investment and Improvement Act Next Generation Equipment Committee (NGEC) requested a feasibility study on the economic impacts of accommodating two or more wheeled mobility devices in the accessible seating area (US Access Board, 2015). The feasibility study indicated that there is space to accommodate two wheeled mobility devices (WhMD) without significant impact on revenue seat loss; however, larger safety issues emerged (K. Hunter-Zaworski, Berthelsdorf, and Shurland 2015) (K. Hunter-Zaworski, Kiff, and Shurland 2014).

This study examined the containment and maneuverability of two large wheelchairs in the provided accessible space, including the space for containment or securement of WhMDs. The project estimated the impact on revenue seating in an Acela-style coach class passenger train. Previous FRA research examined the relationship between spatial consumption and seat loss when two wheeled mobility devices are accommodated in a coach class car and recommended the need for additional study of occupant protection and containment of WhMDs.

Currently in passenger rail operations in the United States, securement or containment devices do not have to be provided for wheeled mobility devices, and passengers sitting in WhMDs may not be provided the same level of containment or protection as passengers sitting in row-to-row train seats. A key consideration is the containment of WhMDs and their occupants. Passengers sitting in row-to-row seats or in seats with a fixed workstation table can be compartmentalized by the adjacent seat or table. These fixtures reduce the free-flight travel distance in the event of a collision. WhMDs need room to maneuver into the accessible seating location, resulting in a large open space, and this space conflicts with the need for containment

and occupant protection. In both Canada and the U.S., there is a need to research the appropriate level of containment for WhMDs on passenger rail vehicles. In the United States and in Western Europe, population demographics have shown that the general adult population is becoming more obese, and many of these individuals require WhMDs such as scooters to increase their mobility(Hunter-Zaworski, K.M., Severson, Kristine, and Shurland, Melissa 2018).

1.2 Compartmentalization and Containment

Compartmentalization is the term more commonly used to refer to the passive safety practice of limiting the amount of travel distance before a person will make contact with a fixed surface in the interior, and containment is a term that refers to rear-facing orientation of WhMDs on transit vehicles.

The base case for analysis was the current coach class car on the Amtrak Acela, which is shown below in figure 1.1.

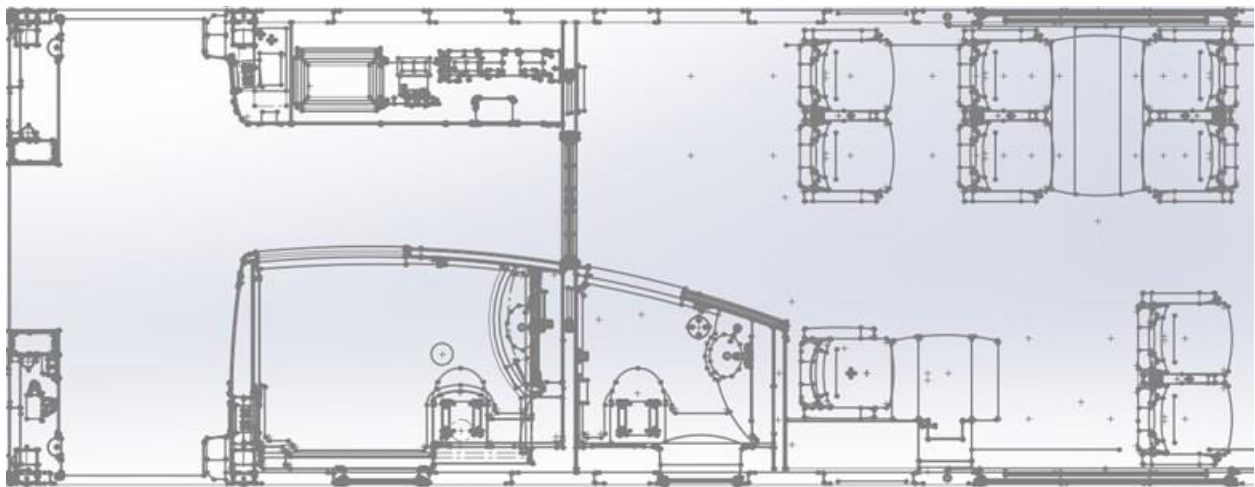

Figure 1.1 Base case is the Coach Class Acela Car

The earlier seating study was done concurrently with the redesign of the accessible restroom. Figure 1.2 shows the base layout used for the seating analysis. This figure incorporates

the new, larger accessible restroom that was designed in the previous FRA research work. Creating a larger accessible restroom resulted in changes to the location of the restroom door from the vestibule area to the coach, and the aisle was moved to one side of the car. In the new restroom configuration, the toilet is oriented in the longitudinal direction, and a sink is adjacent to the toilet. Key dimensions include a standard aisle width of 24 inches and a double seat of 46 inches.

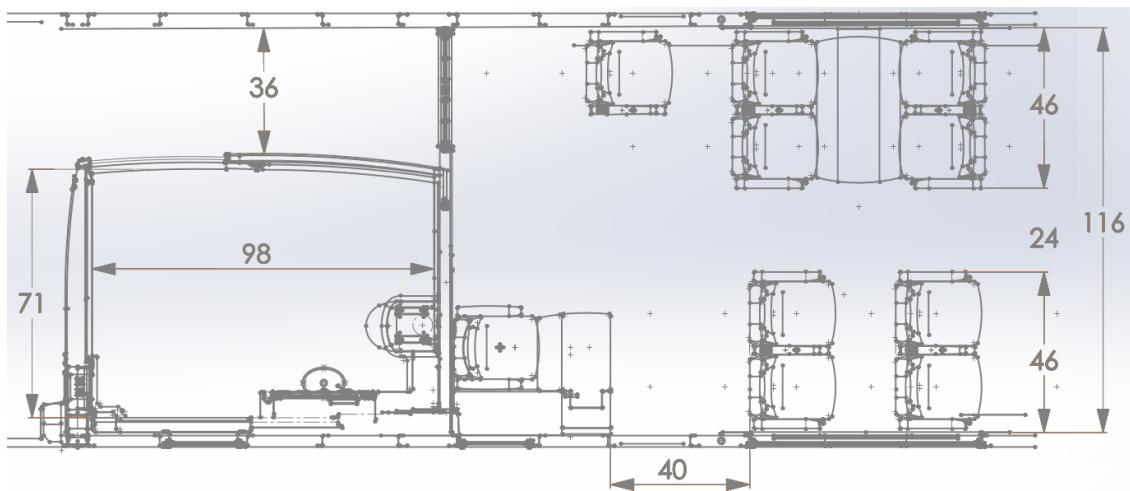

Figure 1.2 Dimensioned layout of base scenario with larger accessible restroom shown.

2 Literature Review

Demand for accessibility within transportation is projected to increase as the numbers of individuals and families with accessibility needs increase (Suen and Mitchell 2000; Huh and Singh 2007). Within the general population, there has been an increase in individuals' size, weight, and age (K. M. Hunter-Zaworski, Rutenberg, and Shurland 2013). The upward trend of these increases is expected to continue in the United States (Suen and Mitchell 2000). In fact, the number of individuals who are elderly or have physical, sensory or cognitive limitations has been projected to be as high as 25 percent of the general population in 2030. These trends will further the demand for accessible spaces (Jette and Field 2007; Waidmann and Liu 2000; Huh and Singh 2007). Passenger rail shows promise as a transportation option for inter-city transportation. However, there is a need to develop and update standards and regulations regarding certain aspects, including passenger protection and containment of wheeled mobility devices.

Functional and safety requirements must be balanced in design conceptualization to ensure safe and independent access to containment systems while maximizing seat revenue generation.

Containment of passengers in wheelchairs and the wheelchairs themselves is an important accommodation to provide for future passenger rail. A number of the challenges in designing passenger cars and seating layouts are similar to the challenges in designing for commercial aviation. Available real estate on rail cars is limited for passenger accessibility accommodation and amenities, and the over-arching need is to optimize passenger protection and safety and minimize weight.

Containment of occupants and their WhMDs is necessary to reduce potential injuries from secondary impact that may result from the collision or derailment of the passenger train.

Injuries from secondary impact refer to injuries that occur when the occupant strikes an interior fixture after free flight, as indicated in figure 2-1. The severity of the injury of the occupant is a function of secondary impact velocity and the stiffness of interior fixtures (Severson, Kristine and Tyrell, D 2012).

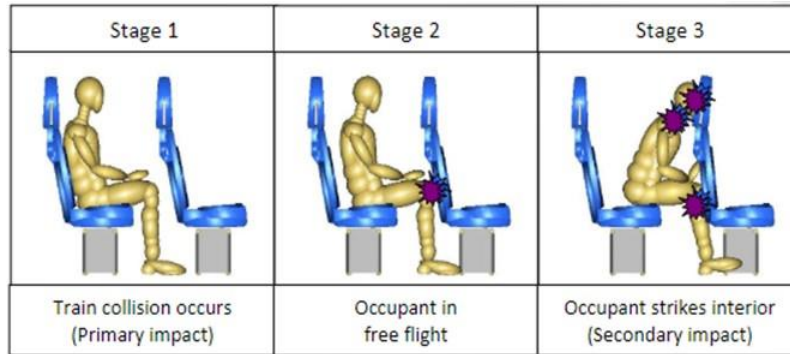

Figure 2-1 Secondary impact in Stage 3 is responsible for injuries as shown

Injury severity is reduced by decreasing the free-flight travel distance of the occupant. Figure 2-2 shows a graph that relates the free flight travel distance to injury severity. Sled tests conducted on rear-facing and forward-facing seats have demonstrated that rear-facing seats significantly reduce the free-flight travel distance, the magnitude of secondary impact velocity, and the severity of the resulting injuries in longitudinal collisions (Severson, K., Parent, D., 2006). In addition, rear-facing seating can also provide containment for WhMDs by restricting the movement of the devices.

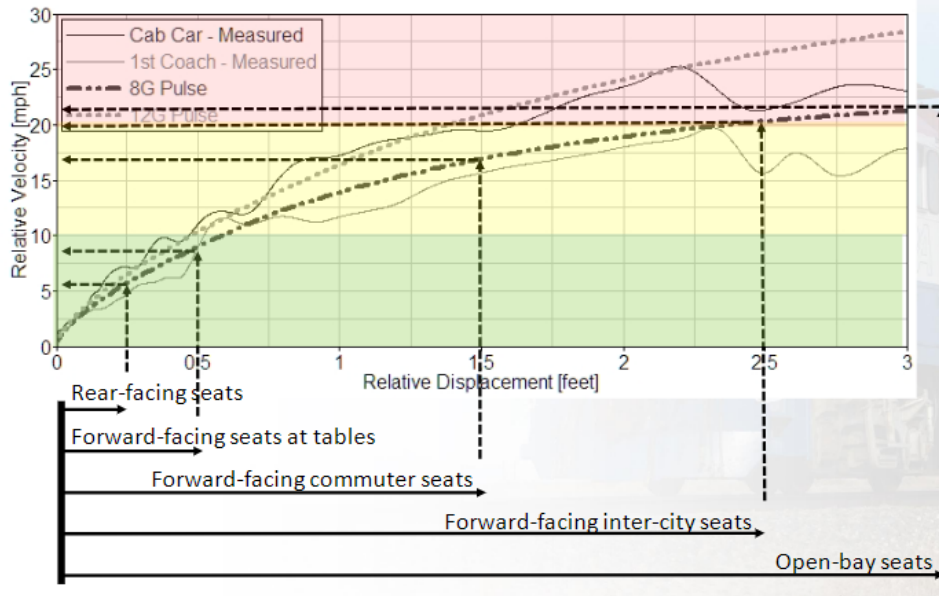

Figure 2-2 Graph of relative displacement associated with occupant free-flight and the relative velocity that is a factor of injury severity.

Designing a passenger rail-specific, rear-facing containment unit may be expensive and time-costly; therefore, it was proposed that commercially available WhMD containment systems be used in layout conceptualization. For passengers occupying wheelchairs, containment for the wheelchair in a rear-facing securement system such as the Q-Strait Quantum™ would increase safety for both the occupant and other passengers. Such a system might be included as a fixture that permitted WhMD users to maneuver independently.

3 Method

3.1 Overall Approach

This project used inclusive and universal design principles to conceptualize seating layouts for a number of accessible seating locations that could also include containment locations. Accessible seating includes seats to which people with reduced mobility may transfer from their WhMD, which is stowed. Containment locations include spaces that are used for passengers who remain seated in their WhMD, and the space may include devices to contain or secure the WhMD. This project focused on accommodating the needs of passengers who may use WhMDs. In addition, by using inclusive design principles, accommodation for a range of WhMDs was considered; the dimensions and descriptions for the WhMDs considered are available in Appendix A.

The layouts for Acela Coach and Business class cars were the base layouts and were modified to include the large accessible restroom. Containment unit dimensions of 28”W x 37”L x 56”H were used based on currently existing rear-facing systems available for large rubber tire public transportation vehicles (K. Hunter-Zaworski, Kiff, and Shurland 2014). Conceptualized layouts were created digitally in 3-D computer-aided design (CAD) software so that multiple layouts could be visualized with accurate dimensions.

3.2 Visualization

Layout scenarios were visualized with models generated with 3-D CAD software and digital human modeling (DHM) to represent wheelchair users and passengers. A key motivation for this work was that CAD and DHM are time- and cost-efficient tools that are successfully able to consider human and ergonomic factors early in design (Demirel and Duffy 2013; Bradtmiller 2000; Demirel and Duffy 2007; Duffy 2016; Chaffin 2007; Ullman 2015). Generated models of

various wheelchairs, including a manual wheelchair, a power-based wheelchair, and a four-wheeled scooter, were used to visualize unoccupied seats and proposed layouts for wheelchair containment. The dimensions for these representative assistive devices are shown in the appendix. To visualize occupied seats, a 95th percentile Caucasian male was used, which was defined as a male 6 ft 1 in (185cm) tall and 216 lbs (97.98 kg). Stakeholders from the rail industry, the accessible population, and designers for accessibility were included in concurrent discussions on the design process and iterations.

4 Results

Scenarios A through D showed power-base wheelchairs within a blocked space for containment. Containment unit space dimensions of 28”W x 37”L x 56”H were modeled after the Q-Strait Quantum™, an automatic, rear-facing containment station designed for large, fixed-route public transit buses. Appendix B includes the technical specifications and a picture of the Quantum system. All shown units were meant to be occupied only when they are rear-facing in relation to the direction of travel, for consideration of occupant containment and passenger safety. Because passenger rail vehicles travel in two directions, two rear-facing systems were required for each vehicle.

Scenarios E through H had problems with containing passengers and their WhMDs; these layouts were unable to accommodate rear-facing containment in either one or both directions of travel or did not show sufficient room for mobility vehicles to access the proposed containment devices. **Table 4-1** summarizes descriptions of each of the scenario layouts.

All scenario layouts included the larger accessible restroom shown in figure 1.2. This larger accessible restroom, discussed in the “Validation of the Accessible Lavatory Recommendations for the Next Generation of Accessible Passenger Rail Cars” (K. Hunter-Zaworski, Kiff, and Shurland 2014), \ permits back-in entrance and forward drive-out of large wheeled mobility devices, as well as assisted transfers to the toilet. Additional studies were done to design a slightly larger accessible restroom that would accommodate a full 360-degree rotation and assisted transfers (Hunter-Zaworski, K.M., Rutenberg, U. 2018). Adequate space was provided for access into the car area and maneuvering into the containment unit.

Table 4-1 Description of scenario layouts

Layout	Description	Number and Type of Wheeled Mobility Devices	Number of seats lost or gained with respect to base case (Figure 1.2)
A	2 accessible spaces with rear-facing containment units	1 power base in each direction of travel	1 seat lost, manual wheelchair stowage
B	3 accessible spaces with rear-facing containment units	1-2 power bases in each direction of travel	1 seat lost, manual wheelchair stowage
C	4 accessible spaces with rear-facing containment units	2 power bases in each direction of travel	4 seats lost
D	4 accessible spaces with rear-facing containment units	2 power bases in each direction of travel	6 seats lost
E	2 accessible spaces, 0 with rear-facing containment units	1 power base and 1 manual	0 seats lost
F	2 accessible spaces, 0 with rear-facing containment units	1 power base in each direction of travel	2 seats lost
G	3 accessible spaces, 0 with rear-facing containment units	1 power base in each direction of travel and 1 manual	1 seat lost
H	1 accessible spaces, 0 with rear-facing containment units	1 power base perpendicular to line of travel	1 seat lost

4.1 Scenario A Layout

Scenario A, shown in figure 4-1, added two WhMD containment spaces to the base layout. The dimensions with a representative human model are shown in an example with only the rear-facing unit occupied.

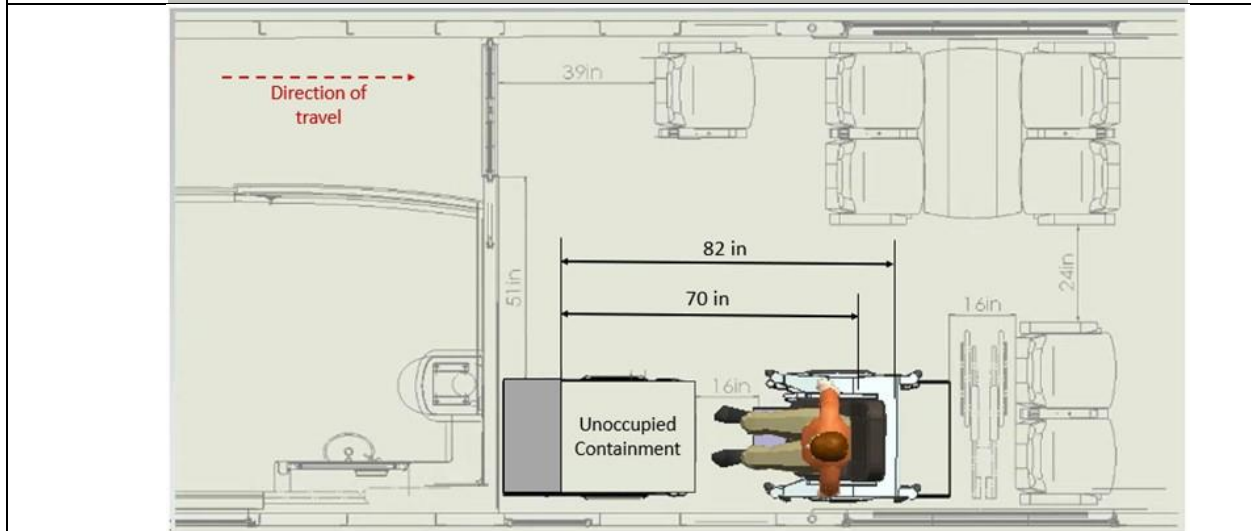
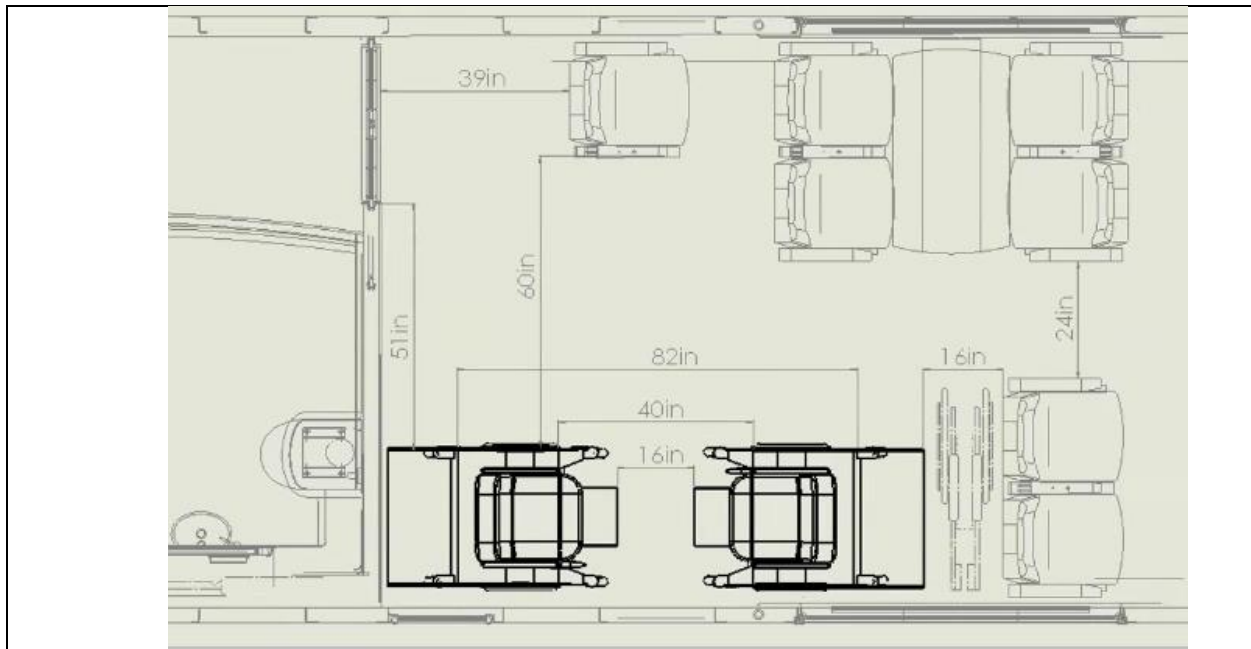

Scenario A

- + Base layout with single seat removed
- + Two containment spaces accommodate one rear-facing WhMD
- + Rear-facing containment available
- + Space for stowage of manual WhMD
- No table access for power-base WhMD

Figure 4-1 Scenario A without and with a 95th percentile male manikin

Additional layout scenarios were modifications of Scenario A, as it was the proposed layout that provided the optimal ratio of rear-facing containment units to seat revenue. In addition, Scenario A also provided space for stowage of an unoccupied manual wheelchair.

In the indicated direction of travel, only the rear-facing seat was proposed to be occupied. Rear-facing seats and rear-facing containment reduce the number and severity of second impact injuries by reducing free travel distance.

4.2 Scenario B Layout

Scenario B, shown in figure 4-2, added an accessible space next to the wall, but there was not enough maneuvering space in the aisle.

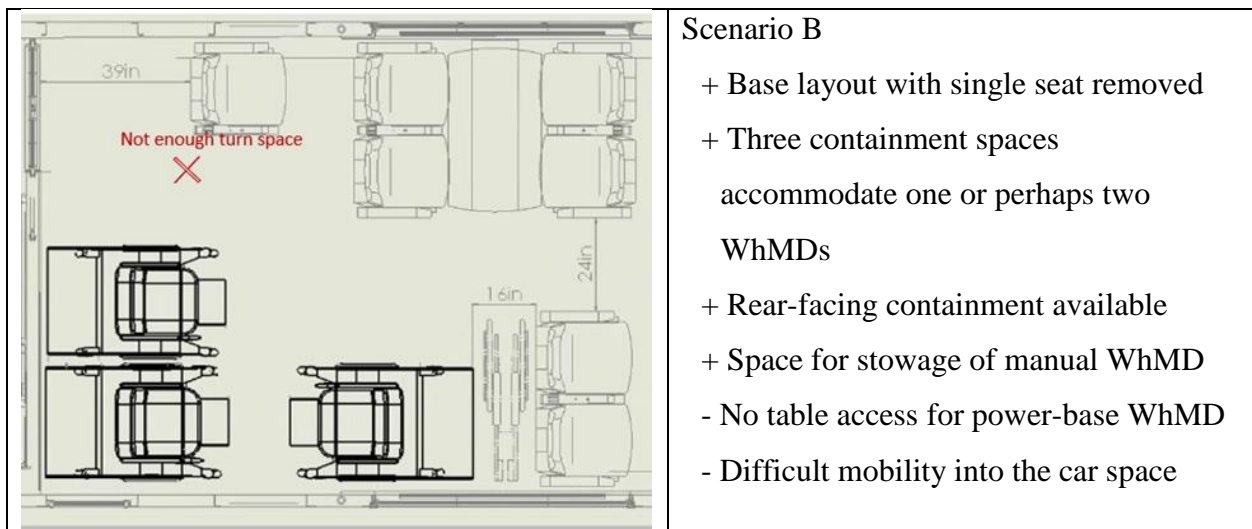

Figure 4-2 Scenario B, layout with extra position but limited aisle width

4.3 Scenario C Layout

Scenario C, shown in figure 4-3, added an accessible space with containment unit space across the aisle. Because of the bi-directional motion of the train, only two WhMDs were accommodated.

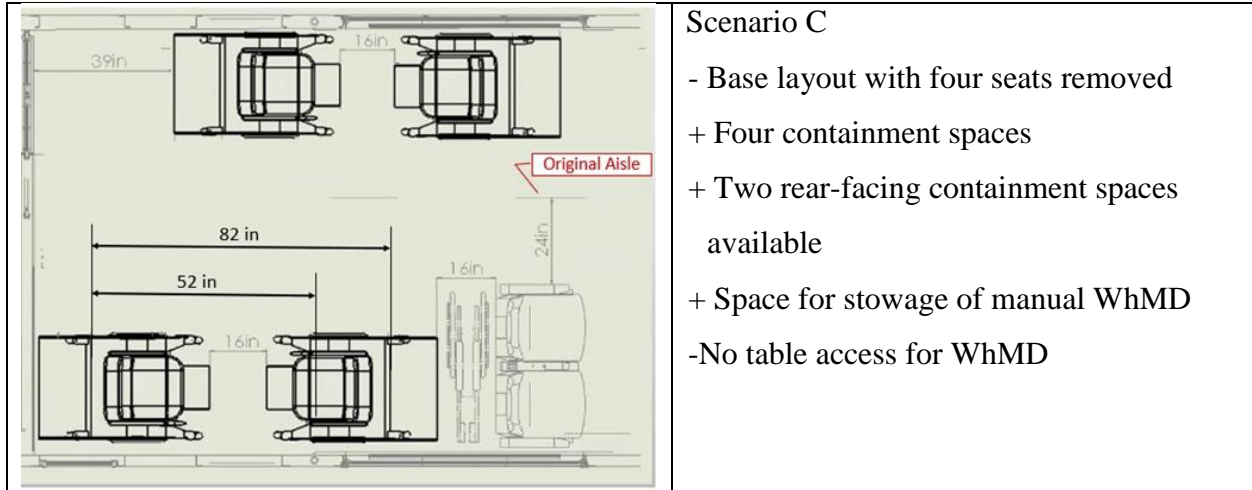
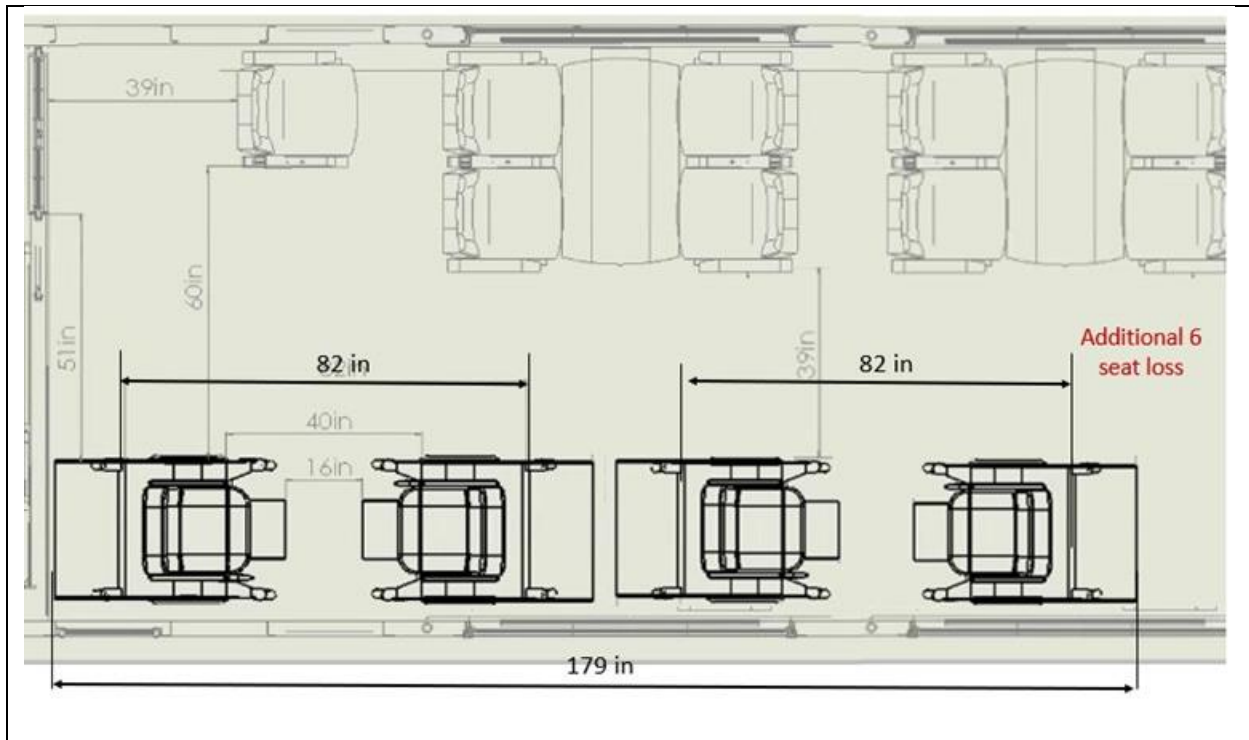

Figure 4-3 Scenario C, accommodation of two WhMDs

4.4 Scenario D Layout

Scenario D, shown in figure 4-4, added an accessible space with containment unit space along the one side of the train. Because of the bi-directional motion of the train, only two WhMDs were accommodated



Scenario D

- Base layout with six seats removed
- Four containment spaces
- + Two rear-facing containment spaces available
- No space for stowage of manual WhMD
- No table access for power-base WhMD

Figure 4-4 Scenario D, accommodation of two WhMDs on same side of the train

4.5 Scenario E Layout

The Scenario E layouts, shown in figure 4-5, did not provide any containment for WhMDs. It might be possible to provide belt-type securement system for the WhMDs, but there was no occupant protection in the forward-facing direction. Both scenario E layouts showed the potential for severe injury for forward-facing WhMDs.

	<p>Scenario E1</p> <ul style="list-style-type: none"> - No containment for WhMD + Base layout with a single seat moved closer to the outside wall + Power-base WhMD + Space for service animal - No table access for power base
	<p>Scenario E2</p> <ul style="list-style-type: none"> - No containment for WhMD + Base layout with a single seat moved closer to the outside wall +/- Room available for uncontained manual wheelchair or service animal - Restricted access to seat with table - No table access for power base

Figure 4-5 Scenario E shows accommodation of one or two WhMDs and limited occupant protection.

4.6 Scenario F Layout

The Scenario F layout, shown in figure 4-6, could also include containment for rear-facing WhMDs. However, the maneuvering space would be more limited. The adjacent companion seat could be moved closer to the outside wall. Access to the companion seat was restricted by the adjacent WhMD. As in scenario E, rear-facing containment could be provided. Longer WhMDs would encroach on the aisle space.

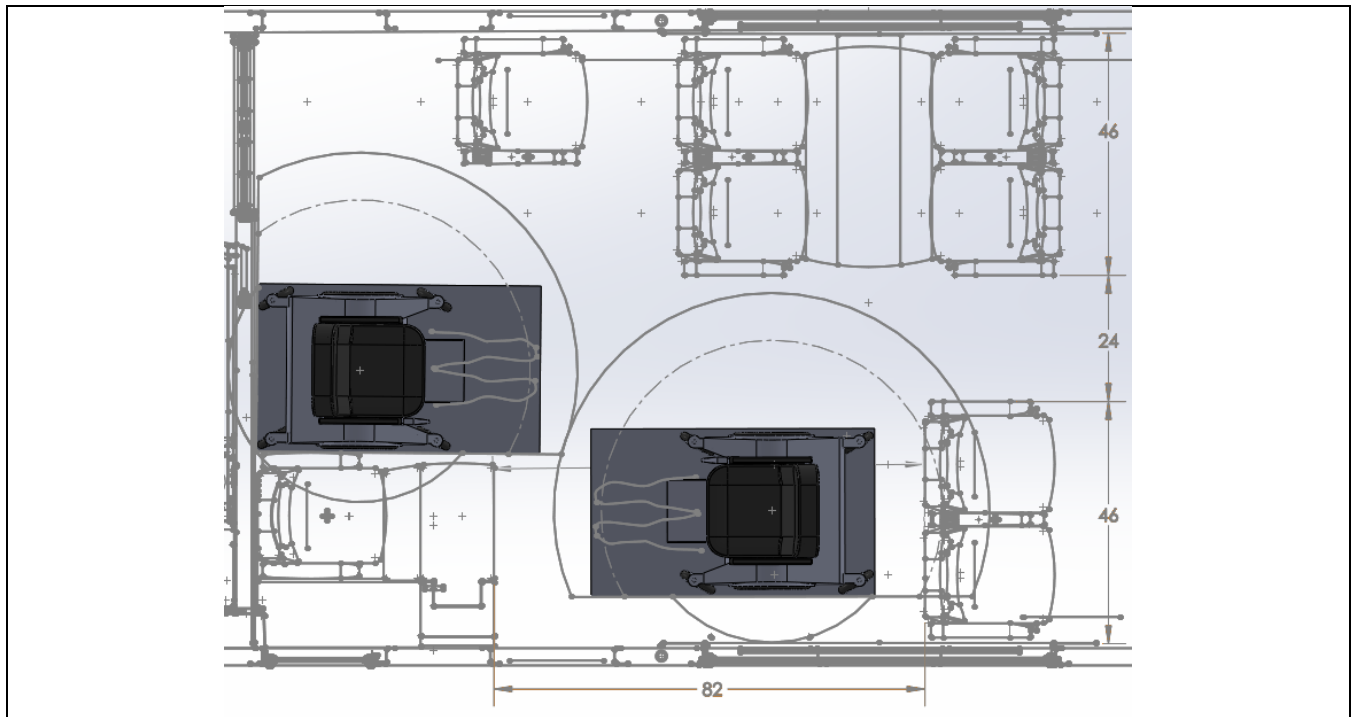

Scenario F

- Limited containment for WhMD
- + Base layout with two seats removed
- Containment possible for one or two power-based WhMDs
- Option for rear-facing containment only in one direction of travel
- Potential difficulty in maneuvering space in the adjacent aisle

Figure 4-6 Scenario F showing options for rear-facing accommodation, with restricted seat access

4.7 Scenario G Layout

Scenario G, shown in figure 4-7, illustrates other seating options; however, additional technologies or securement systems would be needed to stabilize the WhMD. The table in the top area would reduce second impact velocity but might induce other hazards. In the lower area, there was a lack of occupant containment.

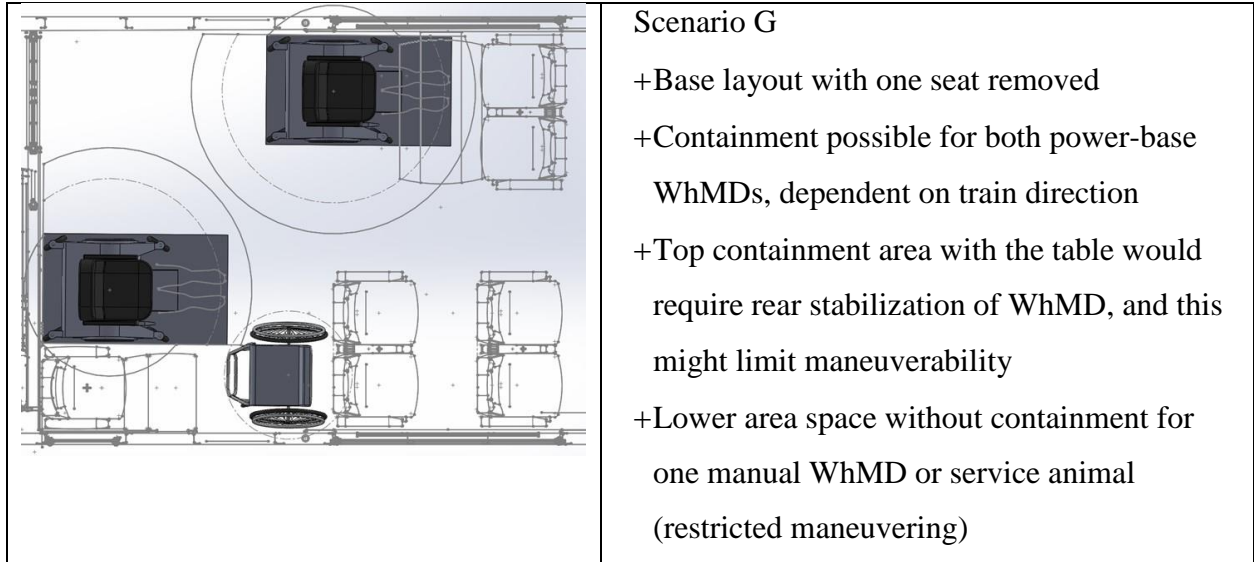

Figure 4-7 Scenario G showing additional options that would require stabilization of WhMD

4.8 Scenario H Layout

Scenario H, in figure 4-8, had a possible stowage space for an unoccupied WhMD. Side-facing orientation of seats on long distance trains is not recommended.

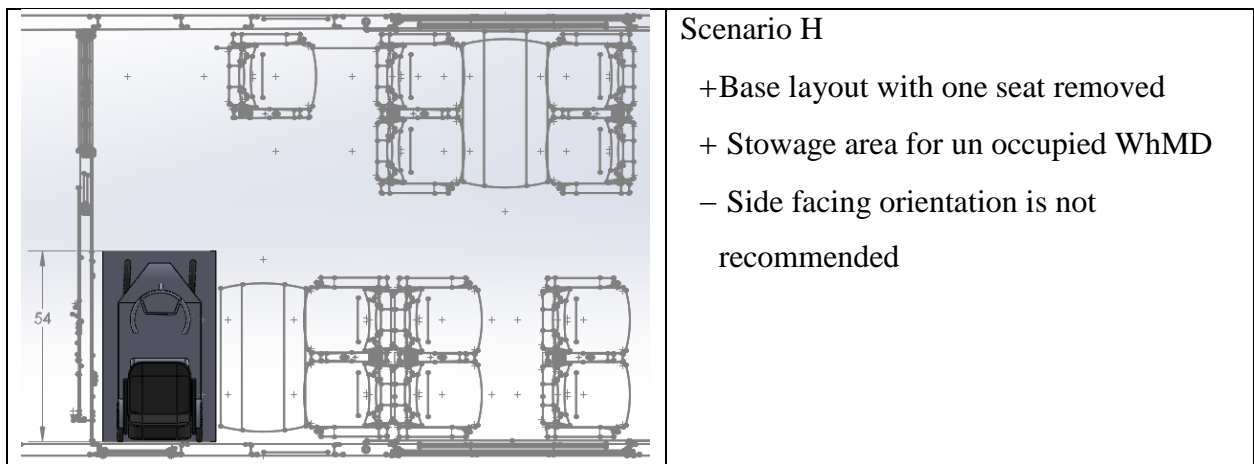

Figure 4-8 Scenario H for stowage of unoccupied WhMD

5 Discussion

5.1 Containment and Compartmentalization

A number of accessible seating scenarios were designed and presented. The inclusion of rear-facing containment for both directions of travel would increase the safety of passengers who remained in their wheeled mobility devices.

In Scenarios A through D, at least one rear-facing containment unit was provided for both directions of travel. In Scenarios A and B, space was also allocated for manual wheelchair stowage for passengers who transfer to a seat rather than remain in their wheelchair. In Scenarios A through D, the secondary impact velocity resulting from relative free flight travel would be high if the WhMD occupant was not restrained by a seat belt to the wheelchair. An improvement to overall safety would be achieved with the containment of the WhMD itself. Scenarios C and D accommodated the containment of two WhMDs but did not account for stowage of manual wheelchairs for seated passengers and also presented a greater loss of seats than Scenarios A and B.

Scenarios E through G could accommodate multiple WhMDs but presented difficulties with access and maneuverability. These scenarios left limited space for maneuvering into a rear-facing containment unit. Scenario F might accommodate uncontained, rear-facing WhMD positioning; however, the relative free flight travel distance would be unconstrained and high in either direction of travel. Scenario H did not accommodate any rear-facing WhMDs. Scenarios B and F presented potential difficulties for WhMDs to access the aisles.

Scenario A would provide one rear-facing containment unit in both directions of travel while resulting in the lowest loss of seats from the base layout of all the scenarios presented.

5.2 Challenges

The study results presented in Chapter 4 showed that there is a significant challenge in accommodating more than one occupied WhMD on passenger trains and in accommodating both directions of travel with rear-facing, accessible spaces with containment. There are competing needs to provide both maneuvering space and passenger containment. Previous research has shown that there are safety benefits for all travelers oriented in the rear-facing position during a crash. However, some passengers may experience discomfort from rear-facing containment, and further research is needed to explore this potential effect on passengers. Rear-facing containment of WhMDs provides a level of independence, and the use of a seat belt on the WhMD provides some reduction in secondary impact velocity resulting from decreased free flight travel distance.

In addition to the safety issues, there is a need to be cognizant of the removal of revenue-generating seating space to provide multiple accessible spaces on passenger rail vehicles. A balance in use of space must be realized.

Scenario A is suggested as a possible compromise between providing one rear-facing containment for each direction of travel and potential seat loss. Scenarios E, F, G, and H had challenges with occupant and WhMD containment. Scenarios A, B, C, D, provided WhMD containment, but unless a seat belt would be used, allowed more free flight travel distance for occupants in the forward-facing configuration.

6 Conclusions and Recommendations

The findings of this study showed that it is possible to provide a rear-facing containment system for one large power-base wheelchair in each direction of travel on board passenger rail cars. Rear-facing containment systems would increase the safety of the wheelchair occupant and other passengers, but some passengers might not be comfortable traveling in a rear-facing orientation. Multiple scenario layouts that would accommodate passengers who wished to remain in their WhMD were presented. Some layouts would accommodate stowage of manual wheelchairs for passengers who transfer to a regular seat.

Scenarios A through D would accommodate at least one rear-facing WhMD containment system for each direction of travel. Scenarios C and D would accommodate two containment units in either direction but would result in the loss of four and six seats from the base layout, respectively. Scenario A and B would only result in the loss of one seat but would also only accommodate one WhMD.

Scenario A is suggested as a compromise in providing two containment units, one in either orientation, with the loss of only one revenue seat.

7 References

- Bradt Miller, Bruce. 2000. "Anthropometry for Persons with Disabilities: Needs in the Twenty-First Century." In *Proceedings of the RESNA 2000 Annual Conference*, 543–548. ERIC.
- Chaffin, Don B. 2007. "Human Motion Simulation for Vehicle and Workplace Design." *Human Factors and Ergonomics in Manufacturing & Service Industries* 17 (5): 475–484.
- Demirel, H. Onan, and Vincent G. Duffy. 2007. "Applications of Digital Human Modeling in Industry." In *International Conference on Digital Human Modeling*, 824–832. Springer.
- . 2013. "A Sustainable Human Centered Design Framework Based on Human Factors." In *International Conference on Digital Human Modeling and Applications in Health, Safety, Ergonomics and Risk Management*, 307–315. Springer.
- Duffy, Vincent G. 2016. *Handbook of Digital Human Modeling: Research for Applied Ergonomics and Human Factors Engineering*. CRC press.
- Huh, Chang, and A. J. Singh. 2007. "Families Travelling with a Disabled Member: Analysing the Potential of an Emerging Niche Market Segment." *Tourism and Hospitality Research* 7 (3–4): 212–229.
- Hunter-Zaworski, K. M., Uwe Rutenberg, and Melissa Shurland. 2013. "Recommendations for the PRIIA Specifications on the Next Generation of Accessible Passenger Rail Cars." In *2013 Joint Rail Conference*, V001T02A015–V001T02A015. American Society of Mechanical Engineers.
- Hunter-Zaworski, Kate, Friederich Berthelsdorf, and Melissa Shurland. 2015. "Validation of the Space for Accommodating Wheeled Mobility Devices on Accessible Passenger Rail Cars." In *2015 Joint Rail Conference*, V001T08A002–V001T08A002. American Society of Mechanical Engineers.
- Hunter-Zaworski, Kate, Robin Kiff, and Melissa Shurland. 2014. "Validation of the Accessible Lavatory Recommendations for the Next Generation of Accessible Passenger Rail Cars." In *2014 Joint Rail Conference*, V001T02A005–V001T02A005. American Society of Mechanical Engineers.
- Hunter-Zaworski, K.M., Rutenberg, U. 2018. "Inclusive and Universal Design Guidelines for HSR Passenger Cars: Safety and Feasibility Review of Accessibility." Federal Railroad Administration.
- Hunter-Zaworski, K.M., Severson, Kristine, and Shurland, Melissa. 2018. "Containment for Occupied Wheeled Mobility Devices on Passenger Trains." In *Proceedings Fo the 2018 Joint Rail Conference*. ASME. <https://asme.pinetec.com/jrc2018/data/pdfs/trk-8/JRC2018-6119.pdfv>.
- Jette, Alan M., and Marilyn J. Field. 2007. *The Future of Disability in America*. National Academies Press.

- Q'Straint. 2017. "Quantum Brochure 2017." Q'Straint.
- . n.d. "Quantum Data Sheet 2017." Q'Straint. Accessed July 19, 2018.
<https://www.qstraint.com/pdf/brochures/2017-quantum-data-sheet-MKM-06-1602.pdf>.
- Severson, K., Parent, D.,. 2006. "Train-to-Train Impact Test of Crash Energy Management Passenger Rail Equipment: Occupant Experiments." In *IMECE2006-14420*,. American Society of Mechanical Engineers,.
- Severson, Kristine, and Tyrell, D. 2012. "Comparison of Interior Crashworthiness Observed in Passenger Train Accidents and 8G Dynamic Seat Sled Tests." In *Proceedings of the SASME/ASCE/IEEE 2012 Joint Rail Conference (Pp. JRC2012-74154)*. Vol. JRC2012-74154. Philadelphia, PA: ASME.
- Suen, S. Ling, and C. G. B. Mitchell. 2000. "Accessible Transportation and Mobility." *Transportation in the New Millennium*.
- Ullman, David G. 2015. *The Mechanical Design Process*. McGraw-Hill Science/Engineering/Math.
- US Access Board. Rail Vehicles Access Advisory Committee-Final Report. July 29, 2015.
https://www.access-board.gov/attachments/article/1765/final_report.pdf
- Waidmann, Timothy A., and Korbin Liu. 2000. "Disability Trends among Elderly Persons and Implications for the Future." *The Journals of Gerontology Series B: Psychological Sciences and Social Sciences* 55 (5): S298–S307.

8 Appendix A

8.1 Representative Wheeled Mobility Device Dimensions

Dimensions used for turning footprints, the occupied spaces in a 360-degree turn of the depicted WhMD, are as defined in Hunter-Zaworki, Kiff, and Shurland, (2014). Only the dimensions of the power-based WhMD were defined with a human occupant.

A.1.1 Manual Wheelchair

A sports model manual wheelchair was used to represent the spatial requirements and 37-inch turning footprint of a manual-type wheelchair. This represents the style of manual wheelchair that may be used by active and independent wheelchair users.

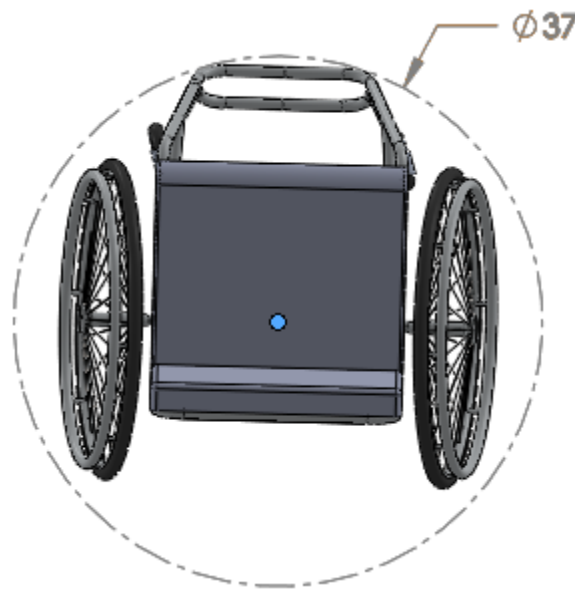

Figure A- 1 Manual wheelchair turning radius and footprint

A.1.2 Power-Based Wheelchair

The large power-base and the footprint incorporate the dimensions of a 95th percentile male, which is defined as a male 6- ft 1 in (185cm) tall and 216 lbs (97.98 kg), with legs slightly extended. This footprint is designed to be more reflective of the population of users. The

mobility aid occupies a footprint of 40 inches long by 32 inches wide and also includes additional toe space for the occupant.

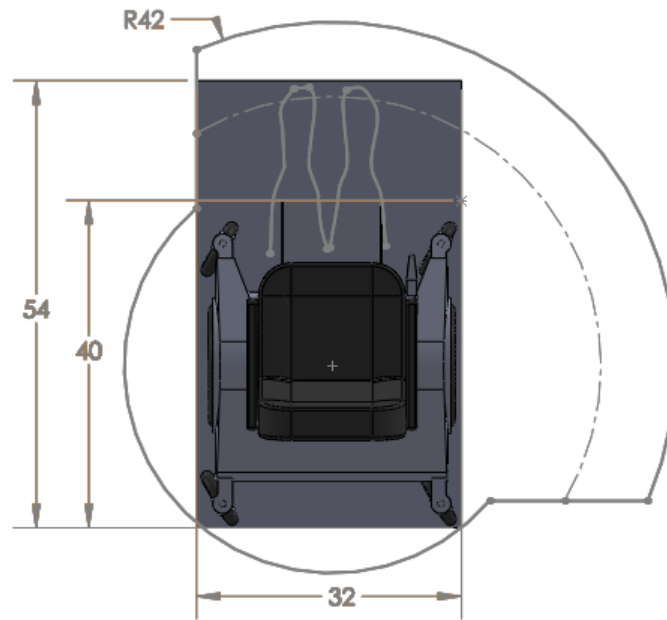

Figure A- 2 Power base radius and footprint

A.1.3 Scooter

Two sizes of power scooter were used for conceptualizing potential layouts. A 48-inch-long scooter would fit within the ADA general footprint for a wheelchair of 30 in by 48 in, and a 54-inch-long scooter should be able to access the train if the platform of the on-board wheelchair lift is 54 in long. In the seating scenarios the 54-inch long scooter could only be stored in the longitudinal position. Otherwise, it would encroach into the aisle. The smaller scooter could be stored in the crosswise and longitudinal positions.

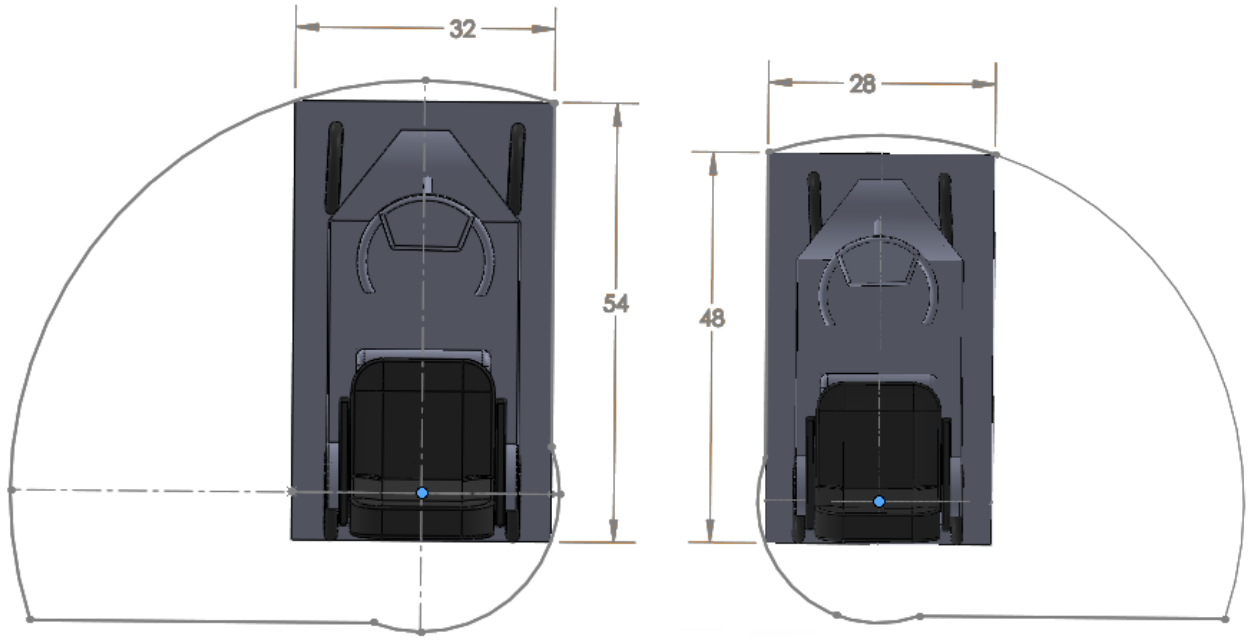

Figure A- 3 Large and medium size scooters radii and footprints

9 Appendix B

9.1 Technical Specifications for Q'Straint Quantum from Quantum Data Sheet (Q'Straint n.d.)

TECHNICAL SPECIFICATIONS

OVERALL DIMENSIONS

With Backrest: 28"W x 37"L x 56"H

Without Backrest: 28"W x 35"L x 34"H

MAXIMUM WIDTH

With Arms Deployed: 37.15" (943.5mm)

TOTAL UNIT WEIGHT

90 lbs. (including mounting plate)

STORED DIMENSIONS

W: 27.35" (694.7mm)

H: 30.92" (785.5mm)

L: 34.04" (864.6mm)

COMPLIANCE

The QUANTUM Securement System meets or exceeds all current regulations for rear-facing transit, European Directives, and ADA/CSA requirements.

The QUANTUM Backrests conform to the performance specifications of FMVSS 201 or ECE R 21, FMVSS 302 and ISO3794.

Figure B-1 shows a picture of the Quantum installed on a transit bus (Q'Straint 2017).



Figure B 1 Picture of Quantum installed on transit bus (Q'Straint 2017)