

©Copyright 2013
Apsara Ravish Suvarna

Transformer-Based Tunable Matching Networks implemented in Silicon CMOS

Apsara Ravish Suvarna

A thesis

submitted in partial fulfillment of the
requirements for the degree of

Master of Science in Electrical Engineering

University of Washington

2013

Committee:

Jacques Christophe Rudell

Robert Bruce Darling

Program Authorized to offer degree:

Department of Electrical Engineering

University of Washington

Abstract

**Transformer-Based Tunable Matching Networks
implemented in Silicon CMOS**

Apsara Ravish Suvarna

Chair of the Supervisory Committee:
Professor Jacques C. Rudell
Department of Electrical Engineering

The growing market for small form-factor, low power wireless communication devices has provided tremendous impetus towards research on multi-mode and multi-standard transceiver designs. A key building block in realizing such a transceiver is a reconfigurable/tunable matching network. In this thesis, two tunable matching networks, designed with the explicit goal of providing large impedance-tunability and low insertion loss, at a fixed resonant frequency have been proposed. The two tunable networks, namely Transformer-plus-L-Match Network (TLMN) and Transformer-plus-Pi-Match Network (TPMN) are fully-integrated and prototype test-chips have been realized in a 40nm bulk CMOS process. The transformer in the two networks provides fixed impedance conversion and switch-capacitance based L/Pi-network provides a variable impedance transformation. A design methodology highlighting the loss mechanism in a transformer-based matching network is presented. Based on this methodology, circuit conditions to obtain minimum insertion loss are derived.

Table of Contents

Table of Contents	ii
List of Figures	iv
List of Tables.....	vi
1. Introduction.....	1
2. Matching Networks for Integrated CMOS Power Amplifiers	4
2.1 Optimal Load for a PA	4
2.2 Basic Types of Matching Networks	6
2.3 Advantages of Tunable Matching Networks in Power Amplifiers	9
2.3.1 Power Requirements and R_{opt} values in different standards	11
2.3.2 AM-PM Conversion in Power Amplifiers	12
2.4 Challenges in Tunable Matching Network Design.....	13
3. Transformer-Based Matching Networks.....	16
3.1 Transformer model	17
3.2 Transformer matching network design to minimize insertion loss	19
3.3 Validation of the transformer-matching network model	25
3.4 Parallel secondary capacitor vs. Series secondary capacitor	28
4. Tunable Matching Network Design.....	31
4.1 Transformer-plus-L-match-based tunable Matching Network (TLMN).....	33

4.1.1 Design details.....	34
4.1.2 Tuning Range Limitations using an L-match	37
4.2 Transformer-plus-Pi-match-based tunable Matching Network (TPMN).....	41
4.2.1 Design details.....	41
4.2.2 Tuning Range Limitations using a Pi-match	43
4.3 Comparison between TLMN and TPMN	46
5. Simulation Results	50
5.1 Simulation results of the TLMN.....	51
5.2 Simulation results of the TPMN.....	54
5.3 Comparison of results of the TLMN and TPMN	57
6. Conclusion	58
References	60

List of Figures

Fig. 2.1 Concept of optimum load impedance in an ideal class-A PA [9]	6
Fig. 2.2 Impedance Down-conversion Networks (a) High Pass Network (b) Low Pass Network.	7
Fig. 2.3 Impedance Up-conversion Networks (a) Low Pass Network (b) High Pass Network.....	8
Fig. 2.4 Transformer as an Impedance Scaling Network.....	9
Fig. 3.1 Frequency-dependent lumped element model for transformer [25]	17
Fig. 3.2 Low frequency approximation of broadband model for transformer	18
Fig. 3.3 Non-ideal transformer with turns ratio ‘n’	20
Fig. 3.4 Equivalent circuit of a loaded transformer with impedances reflected onto primary side	21
Fig. 3.5 Steps involved in simplifying a transformer with parallel secondary capacitor and load R_L	22
Fig. 3.6 (a) Matlab plot of $M=R_{L,eff} / (R_{2,eff} + R_1)$ Vs. C_2 (b) Plot of insertion loss (IL) Vs. C_2 ..	26
Fig. 3.7 Plot of insertion loss Vs. freq. in a transformer with series/parallel secondary capacitors	30
Fig. 4.1 Tunable Matching network implemented with transformer and L/Pi- network.....	32
Fig. 4.2 Circuit implementation of Transformer-plus-L-match-based tunable network (TLMN)	35
Fig. 4.3 Simplified representation of the TLMN	36
Fig. 4.4 Illustration of tuning range limitation due to C_{var} and C_{par} values.....	39
Fig. 4.5 (a) Switch-capacitor branch (b) Equivalent circuit when the switch is in ‘ON’ state	40
Fig. 4.6 (a) Switch-Capacitor Bank (b) Equivalent circuit when the switches are ‘OFF’	41
Fig. 4.7 Circuit implementation of Transformer-plus-Pi-match-based tunable network (TPMN)	42
Fig. 4.8 Simplified representation of the TPMN	43

Fig. 4.9 Tuning Range Limitation in the TPMN: Plot of (a) Real (Z_{in}) Vs. C_{var} (b) C_{par} required to resonate the imaginary part of Y_{in} Vs. C_{var} (c) Insertion Loss Vs. C_{var} – for different values of L_3	44
Fig. 4.10 Limitation in the TLMN due to parasitic capacitances	48
Fig. 4.11 Cross-section of a NMOS transistor in deep n-well.....	48
Fig. 5.1 Layout of (a) TLMN (b) TPMN	50
Fig. 5.2 Plot of $ Z_{in} $ and phase (Z_{in}) Vs. frequency for different switch settings in the TLMN ...	52
Fig. 5.3 Plot of Power gain as a function of input power in the TLMN.....	54
Fig. 5.4 Plot of $ Z_{in} $ and phase (Z_{in}) Vs. frequency for different switch settings in the TPMN....	55
Fig. 5.5 Plot of Power gain as a function of input power in the TPMN	56

List of Tables

Table 5.1 Insertion Loss and phase of S_{21} across Z_{in} values in the TLMN	52
Table 5.2 Insertion Loss and phase of S_{21} across Z_{in} values in the TPMN.....	55
Table 5.3 Comparison of the performance of TLMN and TPMN.....	57

1. Introduction

The expanding market for small form-factor, low-power wireless communication devices, such as cellular-phones, laptops, and tablets, has provided tremendous impetus towards research on multi-mode and multi-standard transceiver designs. The immediate-next goal in these wireless state-of-the-art devices will be to incorporate multiple radios on a single chip in order to satisfy the consumer's short/long-range high-speed/low-power data-transfer requirements. Software defined radio (SDR), wherein a single transceiver chip can be configured to talk with Wi-Fi, GSM or even Bluetooth peripherals has the potential to enable substantial reduction in the size of these devices. However, while the digital backend can be highly programmable and is well suited for 'software-defined' re-configurability, the analog front-end is traditionally designed and optimized for a single carrier frequency (ω_C) and peak output power. Analog circuits are tuned at ω_C with the help of matching networks comprising of inductors, capacitors and transformers in order to maximize the power-gain at radio-frequencies. Thus, single chip SDR, which entails processing signals over a large range of carrier-frequencies, bandwidths, and power-levels would significantly benefit by advances in reconfigurable/tunable matching network design.

A matching network with a reconfigurable impedance transformation ratio opens the door to several other applications as well. One such example is a long-range sensor power-amplifier that is required to maintain constant output-power under the influence of a variable supply voltage. Consider a long-range sensor PA that employs a switching amplifier in the final stage to get good efficiency. Since the power output in switching amplifiers is proportional to

$(\text{Supply Voltage})^2 / R_{\text{load}}$, by varying R_{load} as the supply voltage varies, the output power can be maintained at a constant value [1]. Tunable matching networks can also be employed in systems to improve the performance significantly. Consider a transmitter used in a mobile phone application. The antenna impedance is nominally assumed to be 50Ω but variations as large as 1:7 can occur in the impedance (real and imaginary part) owing to varying environmental conditions [2]. This can lead to degraded performance in addition to causing large voltage-standing wave-ratio (VSWR) variation at PA-antenna interface which could potentially damage the PA [3], [4]. While this problem could be solved by placing isolators between the PA and the antenna, the cost and size of the resulting transmitter will need to be compromised. On the other hand, tunable matching networks which can give independent control of the real and imaginary parts of the matching load, could possibly tackle the challenge of large VSWR with negligible increase in size and system cost. The other major application of tunable matching networks is in RFID systems. In RFID tag or reader, the antenna that interfaces to the microchip is matched in terms of impedance at a single power level. When the power level in the chip varies, the impedance of the chip also varies creating a mismatch between the antenna and the chip impedance. The transmit power and efficiency of the RFID system degrades under such a scenario. If a tunable matching network is employed between the antenna and chip, then it can help match the antenna and chip impedances across different power levels [5]. This will enable longer range of operation for RFID systems.

The immense benefit of tunable matching networks has motivated research in on-chip implementations in recent times. In this thesis, two tunable matching networks have been implemented using transformers and L/Pi-matched networks and the tunability is obtained using

switch-capacitor elements. The tuning networks are fully-integrated in 40-nm bulk CMOS process. While these networks have been designed for use in an integrated PA, the techniques and concepts described are generic to any transformer-based or switch-capacitor based matching network.

The rest of the thesis is divided as follows: In chapter 2, matching networks for integrated CMOS power amplifiers are discussed. The concept of optimal load-impedance for a PA is explained and various benefits of making the PA output matching network tunable are highlighted. The chapter concludes with a discussion on the challenges involved in implementing a tunable matching network. In chapter 3, transformer modeling and design are discussed and conditions for minimizing the insertion loss in a tuned transformer network are derived. Chapter 4 deals with the design of two impedance tuning networks, namely, Transformer-plus-L-match based matching network (TLMN) and Transformer-plus-Pi-match based matching network (TPMN). Design guidelines to ensure low-insertion loss and wide tuning range along with the limitations existing in these structures are presented. The chapter concludes by providing a comparison between these two matching networks. In chapter 5, simulation results of the two tunable matching networks, implemented in a 40nm CMOS process, are presented. The thesis concludes with a summary of the contributions and a discussion on the scope for further work, in chapter 6.

2. Matching Networks for Integrated CMOS Power Amplifiers

Matching networks find extensive use at PA-antenna interface. A key function of the output matching network for PA is to transform the antenna impedance to an ‘optimal-impedance’ at PA output so that peak output power is delivered to the antenna load at the highest efficiency [6]. According to maximum power transfer theory, the load needs a conjugate match to its source in order to transfer maximum power to the load. However, in a PA the optimal load impedance does not correspond to the conjugate-match condition due to voltage swing limitations imposed at the output by finite supply voltage. In this chapter, the concept of an optimal load for a PA is introduced and some of the basic types of impedance matching networks are discussed. The advantages and challenges in incorporating tunability in the matching networks are detailed in the later sections of this chapter.

2.1 Optimal Load for a PA

Power Amplifier is the most power hungry block in wireless transmitters and its efficiency dictates the efficiency of the entire transmitter [8]. Therefore, in order to extract the required output power from the power amplifier while operating at its best efficiency, both voltage and current swings need to be maximized at the PA output. In order to understand the concept of optimal load, let us consider a linear power amplifier. Fig. 2.1(i) shows a power amplifier operating in class-A mode. The maximum current that can be obtained from this PA depends on the sizing of the NMOS transistor. Let us assume that the NMOS transistor has been sized to give a maximum drain current of ‘ I_{\max} ’ at a particular input drive voltage, ‘ V_{in} ’. Assuming that the V_{dsat} for the NMOS transistor is 0V, the maximum peak-to-peak output

voltage swing that can be obtained at the drain of NMOS is $2 \cdot V_{dd}$ (Practically $V_{dsat} > 0V$ and the maximum V_{out} , while maintaining the transistor in saturation, thus will be $2 \cdot (V_{dd} - V_{dsat})$). However, to get this maximum voltage swing under the maximum current output condition of $I_{out} = I_{max}$, the impedance at the output of the PA needs to be set to the right value. This is defined as the optimum impedance, R_{opt} , for the PA. When the impedance at PA output (here, at the drain of the NMOS) is R_{opt} , then both voltage and current swings are maximized resulting in maximum output power, as shown in Fig. 2.1(ii). The antenna impedance is typically 50Ω and there needs to be an impedance transformation network which converts the antenna impedance to an optimum value at the PA output (Fig. 2.1(i)). If the impedance presented to the PA is lower than R_{opt} ($R_{in} < R_{opt}$), the voltage swing is not rail-to-rail and hence the power delivered decreases. This is shown in Fig. 2.1(iii) where V_{out} is less than $2 \cdot V_{dd}$. On the other hand, if the impedance presented is too large ($R_{in} > R_{opt}$), there will be clipping of the output voltage which results in reduced power in the fundamental frequency and increased harmonics. To avoid clipping the driver might need to be backed-off, in which case, the current swing $I_{out} < I_{max}$. This is shown in Fig. 2.1(iv). This implies that depending on the value of the load-resistance, either the output voltage or the output current might be sub-optimal unless the terminating resistance is equal to R_{opt} .

Load pull simulations are done on a PA to establish the value of this optimum impedance during the design of the PA. Depending on the R_{opt} value, a suitable impedance transformation block is designed to convert the 50Ω impedance of the antenna to R_{opt} at the PA output. In the next section some of the basic types of matching networks are discussed.

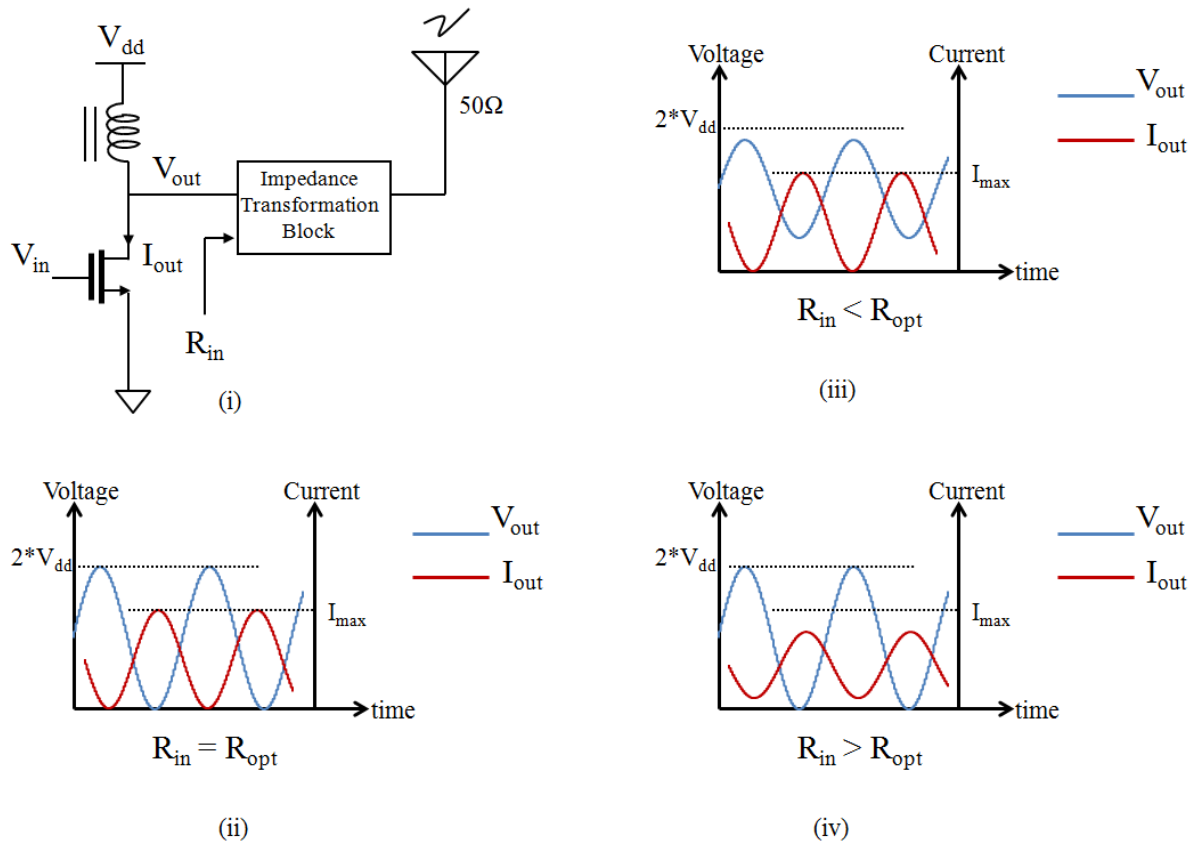

Fig. 2.1 Concept of optimum load impedance in an ideal class-A PA [9]

2.2 Basic Types of Matching Networks

Matching networks are designed using reactive components, such as inductors, capacitors and transformers, in order to minimize losses. Most of the implementations of matching networks are based on L-C ladder topologies and transformers. Fig. 2.2 shows two L-C based matching networks that are used to convert the load impedance R_L to a lower value. In Fig. 2.2(a), a high-pass network is used to achieve the desired transformation while in Fig. 2.2(b) a low-pass network is used. In both of these networks, the components L and C are chosen based on the transformation ratio required at the frequency of operation, ω_0 . Let us analyze the circuit in Fig. 2.2(a) which comprises of inductance L_1 and capacitance C_1 . Here, L_1 and R_L form a parallel R-L network that can be converted into a series network for simplification. The series

value of R_L is given by $\frac{R_L}{(1+Q_1^2)}$ where $Q_1 = \frac{R_L}{\omega_0 L_1}$. Similarly, the series inductance value can be calculated to be $\frac{L_1}{(1+Q_1^2)}$. If a real looking-in impedance is desired between nodes A and GND, then the inductance needs to be resonated out with capacitance C_1 . Hence the capacitance C_1 needs to be, $C_1 = \frac{1}{\omega_0^2 * \frac{L_1}{(1+Q_1^2)}}$. Thus, at resonance, the impedance $Z_{in,1} = \frac{R_L}{(1+Q_1^2)}$ is real with 0 imaginary component.

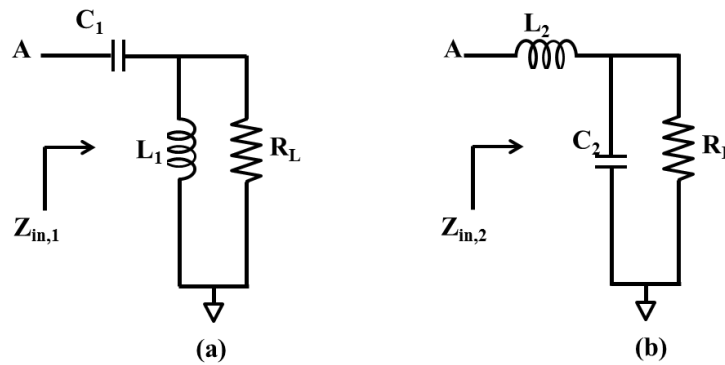

Fig. 2.2 Impedance Down-conversion Networks (a) High Pass Network (b) Low Pass Network

If the load R_L needs to be converted to a certain desired value of $Z_{in,1}$ at the frequency of interest, the value of L_1 that is required in this network is fixed. Similar equations can be obtained for the circuit in Fig. 2.2(b) where a particular value of C_2 is required to achieve the transformation of load R_L to a value $Z_{in,2}$ at ω_0 .

The two networks described above are used to convert the load impedance R_L to a lower value. If the load R_L needs to be converted to higher impedance, then the matching networks in Fig. 2.3 can be used. In Fig. 2.3(a), inductance L_1 and load R_L form a series R-L network that can be converted into its parallel equivalent form where the parallel resistance value is given by $R_L * (1 + Q_1^2)$ and the parallel inductance value is given by $L_1 * (1 + Q_1^{-2})$ where $Q_1 = \frac{\omega_0 L_1}{R_L}$.

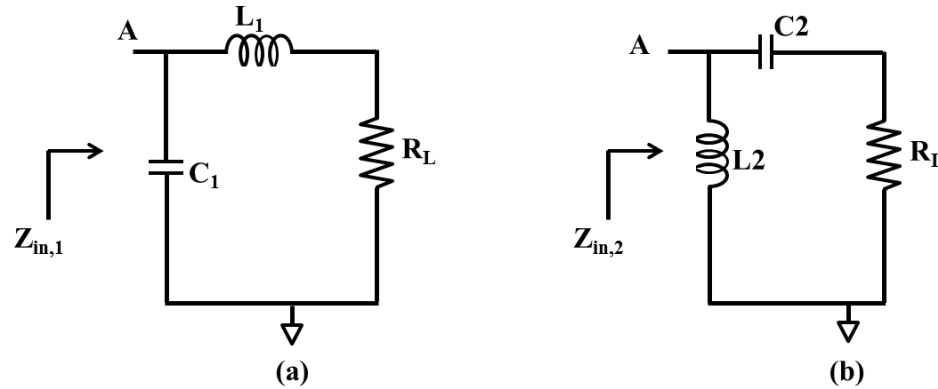

Fig. 2.3 Impedance Up-conversion Networks (a) Low Pass Network (b) High Pass Network

The value of C_1 is chosen to resonate out this parallel equivalent inductance and therefore is chosen to be $C_1 = \frac{1}{\omega_0^2 * L_1 * (1 + Q_1^{-2})}$. Similarly, the matching network in Fig. 2.3(b) can be simplified to obtain the value of $Z_{in,2}$ while cancelling out the imaginary part by appropriately choosing the value of L_2 .

Both the matching networks (Fig. 2.2 and Fig. 2.3) are lossless if ideal components are considered for L and C. However, real inductors and capacitors have finite quality factors and hence some finite non-zero resistances associated with them, which give rise to insertion loss in the network. It can be shown that the insertion loss in these networks is tightly coupled to the transformation ratio desired [7]. Since the on-chip inductors and capacitors have poor quality factors, the insertion loss in these networks for transformation ratios on the order of 10-12 can be prohibitively large. Hence, in order to minimize loss, the transformation of R_L to the desired value (higher or lower) is carried out in multiple stages. If the transformation ratio and quality factor of the L-C components are known, optimal number of stages that gives minimum insertion loss for the network can be calculated [7].

The third type of matching network which is commonly used is the transformer. Unlike in the matching networks discussed above, the insertion loss in a transformer is independent of

the transformation ratio required, to a first order. Fig. 2.4 shows the basic circuit of an ideal transformer block. The turns ratio 'n' is given by $n = \sqrt{L_2/L_1}$ where L_1 and L_2 are the primary and secondary inductances.

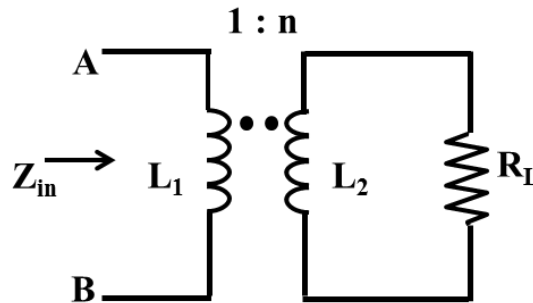

Fig. 2.4 Transformer as an Impedance Scaling Network

If $n > 1$, then R_L is transformed to a lower value between nodes A and B and vice versa. The steps involved in simplifying a transformer circuit and the non-idealities associated with the transformer are discussed in detail in chapter 3.

The impedance transformation blocks described in this section transform the load R_L to a fixed impedance value at the input of the matching network. However, as mentioned in chapter 1, tunable matching networks have advantages over fixed matching networks. The benefits of employing a tunable matching network in a power amplifier are discussed in the next section.

2.3 Advantages of Tunable Matching Networks in Power Amplifiers

It is well known that the matching networks are indispensable in any transmitter where the PA needs to be interfaced to the antenna. In addition, if these matching networks can be made tunable, they can be employed to increase the PA performance significantly, as will be described in this section.

The matching network is traditionally designed to convert the antenna load to an optimum load R_{opt} , which corresponds to peak output power condition in a PA, where the efficiency is maximized. However, there might be a need to operate the PA at back-off power due to several reasons such as to support high peak-to-average ratio (PAR) modulation schemes, to conserve battery power or to mitigate interference to other users. In conventional linear RF PAs, the impedance termination of R_{opt} is sub-optimal when operated at back-off as it results in a smaller voltage swing at the PA output. Hence co-control of load modulation and PA gain together with input power is critical for improving the efficiency at back-off power levels [10]. Load modulation can be achieved by using tunable matching networks which can provide instantaneous optimum impedance according to the input signal envelope to assure high efficiency. In [11], load modulation has been used to achieve amplitude modulation with average efficiency twice that achieved in linear operation of the same PA.

Apart from improving the efficiency of the PA at back-off power levels, PA matching networks which provide variable impedance transformations can enable software defined operation where the PA block can be used across multiple standards. This would result in considerable saving in hardware and hence cost of the transceiver system. The other benefit of tunable matching network is in solving the high VSWR variation problem that occurs due to antenna variation. By providing a fixed output load to the PA even while the antenna impedance is varying, breakdown of the PA due to high voltage swings can be avoided. Tunable networks with independent control of the imaginary part of the impedance can also be used in solving AM-PM conversion issue in the PA, which in turn leads to linearity improvement of the transmit system.

In the next two sub-sections two of the benefits of tunable networks that were mentioned in this part will be explained in more detail.

2.3.1 Power Requirements and R_{opt} values in different standards

To get an understanding about the range of impedances that is required from the output matching network, consider a transmitter designed to operate over two commercial standards: Bluetooth (BT) and Wi-Fi, both of which operate in the unlicensed 2.4GHz ISM band. For a class-1 Bluetooth transmitter, the maximum power that can be radiated from the transmitter is 20dBm [12]. Therefore, let us consider a system which requires a BT transmitter with 20dBm output power, working off a 1.8V supply. For an ideal PA-stage, with no voltage drop across the switch in the final stage, the maximum voltage swing possible at this supply is $2*1.8V$ (peak-to-peak). Therefore, to obtain 20dBm output power while maintaining peak voltage swing possible at PA output, the resistance at the output of the PA needs to be 16Ω . If the same system needs to support Wi-Fi standard as well, in addition to sizing the PA transistor appropriately, the R_{opt} that needs to be presented to the PA needs to be modified to adapt to the desired output power. The maximum transmitter power output in a Wi-Fi system needs to be less than 30dBm [13]. If we need to design the PA to support 30dBm, the value of R_{opt} needs to be 1.6Ω for obtaining a voltage swing of $2*1.8V$ (peak-to-peak) at PA output. So, in order to support both BT and Wi-Fi standards operating at their maximum transmit capability, the PA output matching network needs to convert a 50Ω antenna impedance to 16Ω as well as 1.6Ω . If we define tuning-range as the ratio of the maximum to minimum transformation ratios, then, in this example, a tuning-ratio of approximately '10x' is required. This means that the tuning range requirement of the matching network is 10. Now if the BT transmitter needs to output lesser than 20dBm power, then the R_{opt}

value increases further from 16Ω placing a much higher tuning range requirement. Hence, it is necessary to have a matching network which can support a wide tuning range.

2.3.2 AM-PM Conversion in Power Amplifiers

As mentioned in section 2.1, the matching network that interfaces the PA to the antenna provides R_{opt} at PA output for maximum power output from the PA. In addition to this, the matching network also needs to absorb the drain capacitance on the PA output node in order to operate at GHz frequencies. The matching network is usually designed for a fixed drain capacitance on the PA output node, which is assumed to remain constant irrespective of the output power level. However, this is not the case. In addition to variation in the non-linear drain capacitance, there are several other factors that cause non-linearity in the PA stage, which cause an output signal phase dependence on the amplitude of the PA output signal. This leads to AM-PM distortion in PAs. AM-PM distortion in PAs used in communication systems, which are based on modulation schemes like FM, QPSK, QAM, can result in an increased Error-Vector-Magnitude (EVM) and hence increased Bit-Error-Rates (BER).

Different methods have been adopted in systems to solve the AM-PM distortion problem. Pre-distortion algorithms are used where the AM-PM distortion in the PA is corrected for by adding additional phase shift at the input of the PA, thus increasing the linearity of the PA [30]. Another method to reduce the effect of AM-PM distortion is through the use of a tunable matching network. By monitoring the input power level to the PA and adjusting the R_{opt} to the PA such that a fixed voltage swing results at the PA output, the non-linearity associated with the drain capacitance of the PA can be eliminated. The PM distortion that arises due to capacitance variation at the PA input and due to other non-linearities in the PA output stage can be compensated for by providing a variable imaginary part at the PA output along with variable real

impedance. However, this would require the matching network's tuning bandwidth to be relatively higher as compared to the baseband signal that carries information.

Thus, it is clear that having tunability in matching networks which are employed at the output of the PA can prove to be very beneficial and improve the PA performance significantly. However, there are several challenges involved in building tunable matching networks in Silicon bulk-CMOS process as will be discussed in the next section.

2.4 Challenges in Tunable Matching Network Design

Matching networks are designed using reactive components, such as inductors and capacitors as there are ideally lossless. However, the reactive components that are realized on-chip have finite, low quality factors making them prone to losses. This problem of loss in the matching network is further exacerbated at lower technology nodes due to the increasing demands of the system from the matching network. For example, scaling of supply voltage at smaller process nodes requires that the R_{opt} be small at the PA output in order to extract large output powers. This might demand a transformation ratio of the order of 10-12 from the PA output matching network. The design of the matching network for such high transformation ratios becomes more challenging and the insertion loss in them increases [7]. At low frequencies, the quality factor of inductors is dependent on the resistivity of the metal used in building the inductor while at higher frequencies the amount of substrate loss due to magnetic and capacitive coupling to substrate dictates the maximum quality factor attainable. The quality factor of on-chip capacitors is better than inductors when the frequency of operation is in few GHz. Hence, in order to build low-loss networks, high quality factor inductors need to be designed. One way to build better inductors is by using low-resistivity metal layers which are at a larger distance from the substrate. If the frequency of operation is slightly higher than 10's of GHz, then a pattern

ground shield can be added around the inductor, which can help improve the performance. While it is challenging to design matching networks with good performance on-chip, introducing the element of tunability makes the problem even harder to solve.

Tuning in matching networks can be achieved by either varying the inductors or the capacitors. Multi-tap inductors [17], multi-tap inductors along with switch-capacitors [18], [19] and magnetically-tuned transformers [20] have been considered in some of the prior publications to implement tunability while others have used capacitor as the tuning element [14]. If capacitor is used as the tuning element, variable capacitance can be obtained by using either varactors or switch-capacitor banks. Though varactors can provide continuous tuning, the change in the capacitance value due to signal variation at the varactor leads to AM-PM distortion [21]. Special techniques need to be incorporated both while manufacturing the varactors and designing the networks with varactors in order to eliminate AM-PM distortion [22]. While these techniques solve the problem of distortion and non-linearity, they eliminate the goal of realizing a single CMOS chip for the entire transceiver block. Tuning the capacitors using switches does not pose linearity problems as severe as the varactors. However, the switches, due to their non-zero resistance, can cause considerable increase in the insertion loss in the system. This has the effect of degrading the capacitor Q, and becomes more problematic at higher frequencies. In addition to loss, switches also introduce considerable amount of parasitics which will limit the tuning range. Hence, if switches are used for tuning, the choice of inductor or capacitor as the tuning element depends on the impact of the switch resistance on the overall loss and tuning range in the network.

Most of the implementations of tunable matching networks for PA-antenna interface are based on LC ladder topologies, T-network, Pi-network, etc. While some of them are fabricated in

high voltage silicon-on-insulator processes and make use of varactors for obtaining tuning [14], the others make use of off-chip components to realize the matching network [15], [16]. Though better performance can be obtained by using off-chip components and high-voltage varactors in better processes, the goal of realizing the entire system on a single-chip is eliminated. With the objective of integrating the entire matching network in bulk-CMOS processes, in this work, switch-capacitor banks along with on-chip transformers, inductors and capacitors have been used to obtain the required tuning in the matching network. Unlike in implementations that need large control voltages to operate the switches or tune the varactors, the switches in this design operate off a 1V control voltage.

3. Transformer-Based Matching Networks

Matching networks which are desired to operate in a given frequency band can be designed using transformers or LC ladders. While LC-ladder based circuits such as a T-network, Pi-network, or a combination of these are well suited for low transformation ratios, their insertion loss is prohibitively high for transformation ratios on the order of 10-12 [7], [23]. Transformers, on the other hand, are ideally suited for such applications because the insertion loss is independent of the transformation ratio [24]. In addition to the above mentioned advantage, transformer-based networks serve other purposes, including as a balun, to interface a differential PA with a single-ended antenna. In addition, it can also eliminate the necessity of a large choke inductor by utilizing the center-tap of the transformer to deliver a bias to the PA input or output.

For high-power PAs using transformer-based matching networks, the overall system power-efficiency will be dependent on the insertion-loss of the transformer. Hence, in this chapter, criteria for designing transformer networks are developed with the goal of minimizing insertion loss. The assumption made for developing optimum design guidelines is that the primary and secondary inductance values in the transformer are chosen based on the impedance transformation ratio requirement and are fixed in value. The optimization is in terms of the selection of a secondary capacitor value for the given transformer such that the insertion loss of the loaded transformer network is at its minimum. Section 3.1 describes the modeling of the transformer. In section 3.2, a methodology for simplification of the transformer network is presented and equations for insertion loss are derived. Based on these, the selection criteria for secondary capacitance are obtained. The validation of the methodology developed in section 3.2

is presented in section 3.3, while section 3.4 compares and contrasts the use of a parallel vs. series secondary capacitors in the transformer-based matching network design.

3.1 Transformer model

Transformers can be modeled using pi-models, similar to inductors. Fig. 3.1 shows the transformer model which accommodates the center-tap connection and distributed capacitance effects at high frequencies. C_p and C_s are terminal-to-substrate capacitances, R_b is the pattern ground shield parasitic resistance, C_c is the terminal-to-terminal capacitance and R_p , R_s are the equivalent series resistances on the primary and secondary terminals which capture the ohmic losses, skin effect and proximity effects. L_p and L_s are the primary and secondary inductances and the coupling co-efficient between primary and secondary is given by ' k_m '.

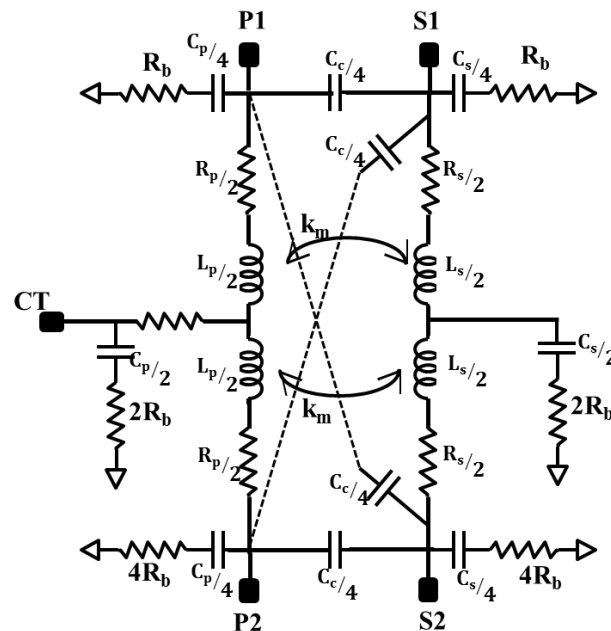

Fig. 3.1 Frequency-dependent lumped element model for transformer [25]

If the frequency of operation is much lower than the self-resonance frequencies of primary and secondary inductances, then for the sake of simplicity, the model can be approximated as shown

in Fig. 3.2 (the center-tap becomes important for common-mode analysis and can be ignored while considering differential operation of the circuit).

Since on-chip transformers and inductors implemented using the metal-stacks available in standard CMOS technology have lower quality factor than discrete off-chip components, the values of R_p and R_s could be quite high. This is primarily due to the power loss due to the finite resistance of the metal windings, in addition to the lossy substrate [26]. In advanced technology nodes such as 28 and 40nm, this problem is even more pronounced because of the shrinking height of the metal stack through technology scaling. Hence, it is essential to design the transformer network carefully such that the losses due to high R_p and R_s are reduced. Else, the insertion loss of the matching network could be quite high which in turn will reduce the overall efficiency of the system where the matching network is employed. In the next section, the choice of the secondary capacitor for obtaining minimum insertion loss is discussed at length using the transformer model described above.

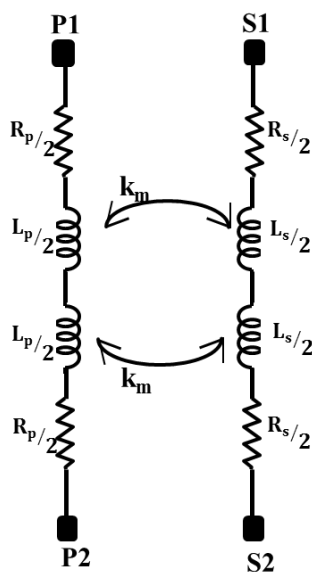

Fig. 3.2 Low frequency approximation of broadband model for transformer

3.2 Transformer matching network design to minimize insertion loss

Matching network design requirements can be quite different depending on the application. For example, the matching network used at the receiver front-end for LNA matching needs to be optimized for low noise, good matching with antenna impedance and voltage gain. For VCO applications, the matching network needs to have good phase noise and narrow-bandwidth implying a high Q. For a PA matching network, impedance transformation with minimum loss in the network is of utmost importance. Hence, in this section, design of transformer-based matching network which provides minimum insertion loss is discussed.

Loss in matching networks can be characterized in different ways. While one way is to calculate loss which is independent of the source impedance and the termination load impedance, the other method is to characterize the loss of the entire network (which includes the source and load resistance). In some publications, the maximum available gain, G_{\max} , is used as a figure-of-merit to characterize the loss since it is independent of the termination impedances. (G_{\max} , in a transformer, corresponds to the power transfer from the primary coil to the secondary coil under bilateral conjugate matched conditions) In [27], G_{\max} of the transformer is derived and ways to improve the G_{\max} are discussed. However, in applications where transfer of power is the primary objective, it makes more sense to characterize the network insertion loss (for given termination source/load impedances) since it helps in estimating the actual power delivered to the load in presence of the matching network. Based on this, insertion loss (IL) of an impedance matching network can be defined as –

$$IL = 10 \log \left(\frac{P_{\text{load}}}{P_{\text{load}} + P_{\text{loss}}} \right)$$

where P_{load} is the power delivered to the load and P_{loss} is the power dissipated in the matching network. Note that the matching network's insertion loss is dependent on the value of load impedance and changes when the load is changed. In this section, the criteria for choosing a secondary capacitor for a given transformer, in a transformer-based matching network, are described. Equations for insertion loss in the transformer-matching network are also provided.

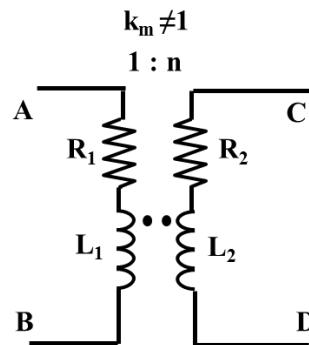

Fig. 3.3 Non-ideal transformer with turns ratio ‘n’

Consider the transformer shown in Fig. 3.3. The terminals (A, B) represent the primary side of the transformer and terminals (C, D) represent the secondary side. L_1 and L_2 are the primary and secondary inductances, respectively. The turns-ratio of the transformer denoted as ‘n’ is defined as $n = \sqrt{L_2/L_1}$ and the magnetic coupling-coefficient is denoted as k_m . R_1 and R_2 are the equivalent series resistances on the primary and secondary windings. The insertion loss in the network arises due to these resistances and hence they need to be minimized. The quality factor (Q-factor) of primary and secondary windings, Q_1 and Q_2 , are defined as $Q_1 = \omega L_1/R_1$ and $Q_2 = \omega L_2/R_2$ respectively. Theoretically, there are two equivalent techniques to model the Q-factor of an inductor: first, with a series resistance R_s , where $R_s = \omega L/Q$, and second, with a parallel resistance R_p , where $R_p = Q\omega L$. However, it is important to note that representing the

inductor and the series equivalent resistor in their parallel equivalent form will lead to inaccurate results in a transformer. In section 3.3 the incorrect conclusion drawn by assuming the parallel-resistance model will be highlighted.

If the transformer described above is terminated with a resistance R_L at the secondary, the input impedance at the primary can be obtained by simplifying to a form shown in Fig. 3.4(b). Non-ideal magnetic coupling between L_1 and L_2 results in a leakage inductance which has been accounted for on the primary side, whose value is $L_1 * (1 - K_m^2)$ [28]. The impedance at the secondary, which consists of L_2 in parallel with $(R_L + R_2)$ is reflected on the primary with a scaling-factor of $(n/k_m)^2$ which is the effective turns-ratio [28]. The reflected impedance appears in series with the primary leakage inductance, $L_1 * (1 - K_m^2)$ and primary ESR, R_1 .

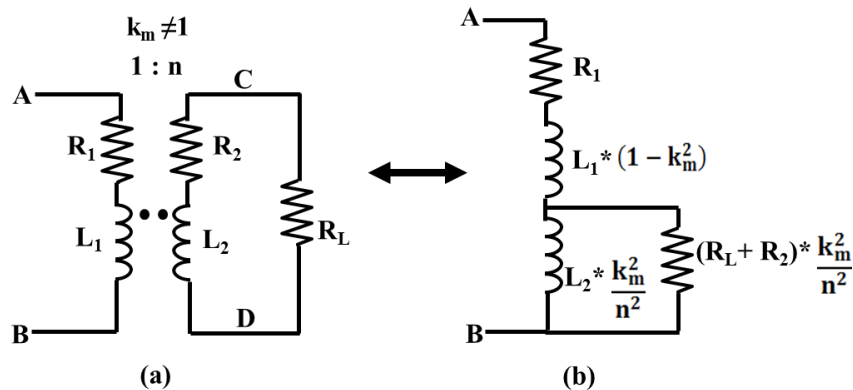

Fig. 3.4 Equivalent circuit of a loaded transformer with impedances reflected onto primary side

Fig. 3.4(b) is the simplest representation of a transformer and helps in accurately evaluating the looking-in impedance, Z_{in} , as seen from the primary of the transformer. It can be observed from this model that impedance Z_{in} has both resistive and inductive components. However, in most applications, it is desirable for the transformer to be ‘tuned’ to ensure the input-impedance is real in the frequency range of interest. Shunt/series capacitances can be added at the

primary/secondary terminals to resonate the inductance. Out of these four cases, it can be shown that the shunt-capacitance at the secondary is the most generic case. In this section, simplification of the transformer network is discussed, which will provide an intuition for the impact of tuning-capacitance on the insertion-loss.

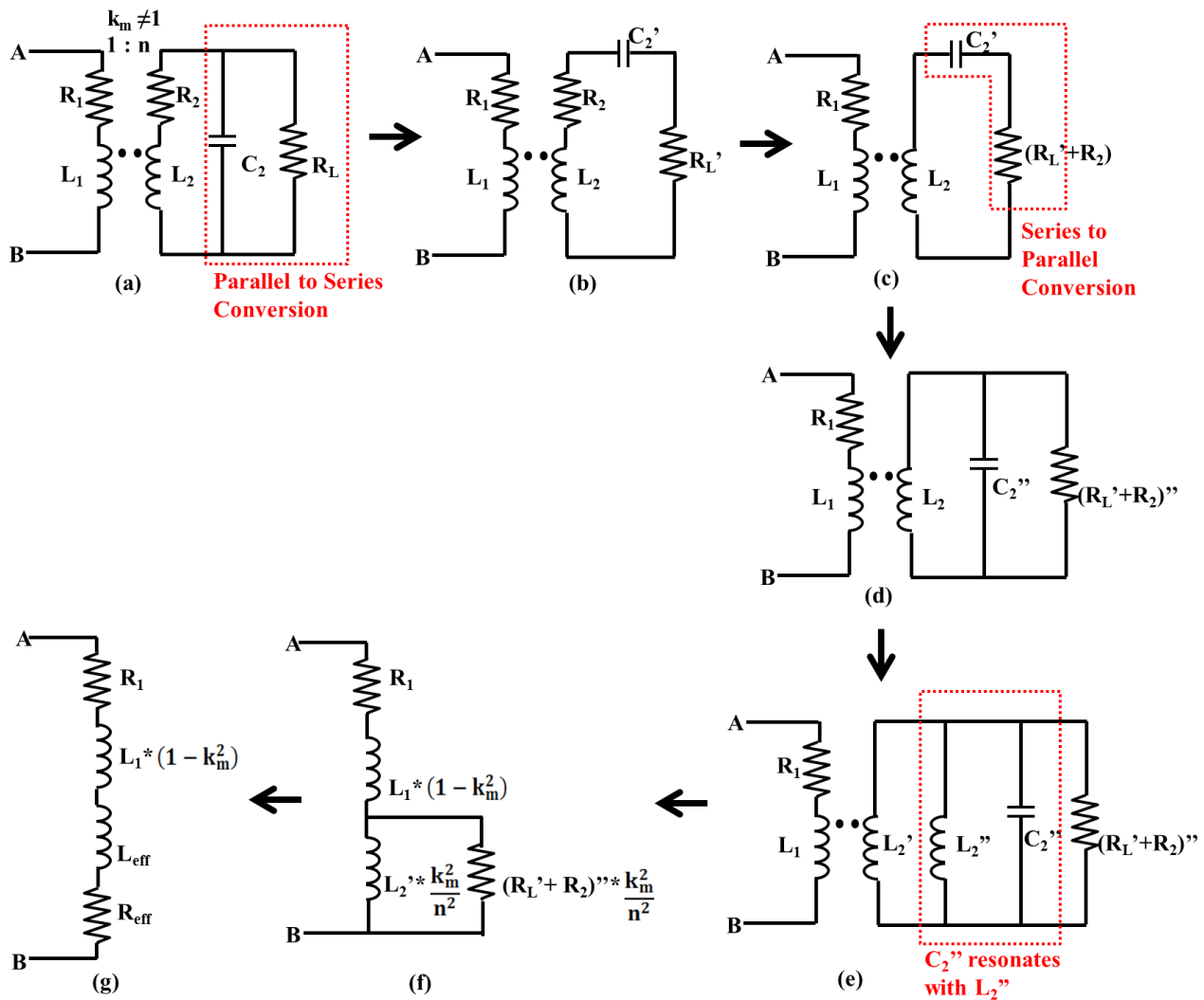

Fig. 3.5 Steps involved in simplifying a transformer with parallel secondary capacitor and load R_L

The transformer-model with the secondary tuning capacitance is shown in Fig. 3.5(a). The secondary capacitor C_2 and R_L form a parallel R-C network. At the center frequency ω_0 , the

parallel-circuit can be transformed to its narrowband equivalent series network, R_L' in series with C_2' , as shown in Fig. 3.5(a) and (b), where

$$R_L' = \frac{R_L}{(1 + Q_p^2)} \quad (1a)$$

$$C_2' = C_2 * (1 + Q_p^{-2}) \quad (1b)$$

$$Q_p = \omega_0 C_2 R_L \quad (1c)$$

The resistance R_L' and R_2 form a voltage divider network. As a result, in order to minimize the losses R_L' needs to be large compared to R_2 . From (1a)-(1c), one observes that R_L' is maximized by minimizing Q_p and C_2 . Thus, a low value of C_2 suppresses the contribution of R_2 to the total insertion-loss. Next, to study the impact of C_2 on the insertion loss caused due to primary side loss-resistance R_1 , the circuit transformations described in Fig. 3.5(c-g) are discussed.

The series network consisting of C_2' and $(R_L' + R_2)$ can be transformed to an equivalent parallel network as shown in Fig. 3.5(c) and (d) with

$$(R_L' + R_2)'' = (R_L' + R_2) * (1 + Q_s^2) \quad (2a)$$

$$C_2'' = \frac{C_2'}{(1 + Q_s^{-2})} \quad (2b)$$

$$Q_s = \frac{1}{\omega_0 C_2' (R_L' + R_2)} \quad (2c)$$

The effective shunt-capacitance resonates with a part of L_2 at ω_0 . Inductance L_2 can be represented as a parallel combination of two inductors, say L_2' and L_2'' , such that L_2'' and C_2'' satisfy (3a). The residual inductance L_2' is then given by eqn. (3b)

$$L_2'' = \frac{1}{\omega_0^2 C_2''} \quad (3a)$$

$$L_2' = \frac{L_2 L_2''}{L_2'' - L_2} \quad (3b)$$

Next, as shown in Fig. 3.5(f), the secondary impedance, L_2' in parallel with $(R_L' + R_2)''$, is referred from the secondary to the primary of the transformer. As a result the impedances are scaled down by a factor of $(n/k_m)^2$. On the primary side, the parallel to series conversion of $L_2' * (k_m^2/n^2)$ and $(R_L' + R_2)'' * (k_m^2/n^2)$ gives L_{eff} and R_{eff} , as indicated in Fig. 3.5(g). Resistance R_{eff} represents the loading on the primary of the transformer and can be obtained using (4a) and (4b).

$$Q_{\text{pri}} = \frac{(R_L' + R_2)''}{\omega_0 L_2'} \quad (4a)$$

$$R_{\text{eff}} = (R_L' + R_2)'' * \frac{k_m^2/n^2}{(1 + Q_{\text{pri}}^2)} = R_{L,\text{eff}} + R_{2,\text{eff}} \quad (4b)$$

R_{eff} can be split as $R_{L,\text{eff}}$ and $R_{2,\text{eff}}$ as given in equations (5a) and (5b). $R_{L,\text{eff}}$ represents the load resistor and $R_{2,\text{eff}}$ represents the ESR R_2 when referred to the primary side.

$$R_{L,\text{eff}} = R_L * \left(\frac{1 + Q_s^2}{1 + Q_p^2} \right) * \frac{k_m^2/n^2}{(1 + Q_{\text{pri}}^2)} \quad (5a)$$

$$R_{2,\text{eff}} = R_2 * (1 + Q_s^2) * \frac{k_m^2/n^2}{(1 + Q_{\text{pri}}^2)} \quad (5b)$$

In order to minimize insertion loss, the value of $R_{L,eff}$ needs to be much larger as compared to the two loss components, $R_{2,eff}$ and R_1 . Since all three resistances appear in series, to minimize the IL, the factor M must be maximized, where

$$M = \frac{R_{L,eff}}{R_{2,eff} + R_1} \quad (6)$$

Several important observations can be made based on (6). First, if C_2 is minimized, from (1a)-(1c) it can be seen that R_L' is maximized. However for small values of C_2 , $R_{L,eff}$ also reduces thus increasing the loss due to R_1 . In summary, there exists an optimum value of C_2 for which the ratio M is maximized i.e. loss due to both R_1 & R_2 are minimized. This optimum value of C_2 gives the least insertion loss for a given transformer. The insertion loss can be calculated using (7).

$$IL = 10 * \log \left[\frac{R_{L,eff}}{R_{L,eff} + R_{2,eff} + R_1} \right] \quad (7)$$

The above criterion has been used in selecting the secondary capacitor C_2 in the design of tuning networks in chapter 4.

3.3 Validation of the transformer-matching network model

An example validating the model given in the previous section and conditions for choosing C_2 are described below. A transformer with turns-ratio 1:2 and a primary inductance of approximately 400pH were chosen to construct the transformer matching network. The exact values of primary and secondary inductances were obtained from HFSS simulations of the transformer that was laid out in a 40nm CMOS process. These values were found to be $L_1=324\text{pH}$ and $L_2=2.7\text{nH}$. The value of ESRs on primary and secondary windings were obtained

to be $R_1=300\text{m}\Omega$ and $R_2=3.26\Omega$ and the coupling coefficient, $K_m=0.63$. The center frequency was chosen to be $f_0=2\text{GHz}$ as it is close to GSM, Bluetooth and Wi-Fi frequencies.

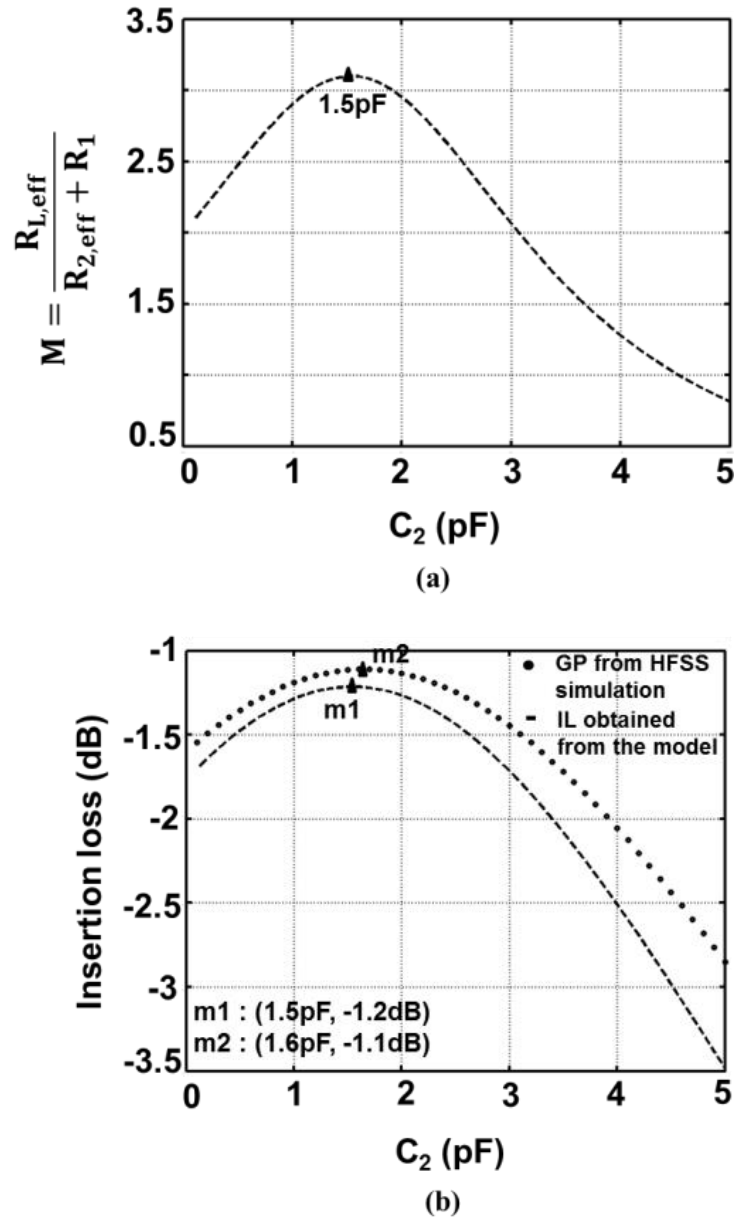

Fig. 3.6 (a) Matlab plot of $M=R_{L,\text{eff}} / (R_{2,\text{eff}} + R_1)$ Vs. C_2 (b) Plot of insertion loss (IL) Vs. C_2

The load for the transformer network is $R_L=50\Omega$, which represents the nominal antenna impedance value. In order to choose a C_2 that gives the least insertion loss, the ratio M given by

eqn.(6) needs to be maximized. Fig. 3.6(a) shows the plot of M versus C_2 , obtained from matlab. It can be seen that the ratio is maximum for $C_2=1.5\text{pF}$.

In order to validate the model, a 4port s-parameter file was obtained for the transformer from HFSS simulation and the loss of the network versus C_2 was simulated using this s-parameter file in cadence. The plot of insertion loss, GP versus C_2 is shown in Fig. 3.6(b) along with the plot of IL obtained using eqn.(7). In HFSS simulation, the optimum C_2 obtained is 1.6pF and $\text{IL}=-1.1\text{dB}$. The optimum value obtained from the model is close to the above values and they are $C_2=1.5\text{pF}$ and $\text{IL}=-1.2\text{dB}$. The two graphs, Fig. 3.6(a) and Fig. 3.6(b), validates the accuracy of the transformer model developed in the previous section. The slight mismatch in the two curves is due to simplified model of a transformer instead of a comprehensive Pi-network.

An important point to be noted is that the secondary inductance of the transformer cannot be represented in the parallel form as $L_2||R_p$ where $R_p = \omega Q_2 L_2$, where Q_2 is the Q-factor of the secondary winding. The results obtained for such a representation will not be equal to the simplified model obtained in Fig. 3.5(g), which is the exact representation, as validated by simulations. Also, representing the secondary inductance in a parallel equivalent form would mean the loss due to the resistance R_p is independent of secondary parallel capacitor C_2 . The reason for this is because R_p would appear in parallel with load resistor R_L and the two could be compared directly for estimating loss due to R_p . However, the insertion loss due to finite Q-factor of L_2 is dependent heavily on the parallel secondary capacitor, as was discussed in section 3.2 and as validated in the plots of Fig. 3.6(b).

Based on the theory developed in this section, the steps involved in designing a transformer-based matching network can be stated as follows:

1. Determine the turns-ratio required to achieve the required transformation ratio
2. Choose L_1 and L_2 values which meet the turns-ratio specification based on the area and SRF (self-resonance frequency) constraint
3. Layout the transformer such that the Q-factor in the primary and secondary windings are maximized
4. Once the transformer layout is ready, select the value of secondary capacitor based on the criteria mentioned in the above section in order to obtain least insertion loss.

It is important to note that the primary capacitance does not play any role in determining the insertion loss in the network (unless the transformation requires a very large R_{in} , where the quality factor of the on-chip capacitor might add to the insertion loss) and hence is chosen solely based on the residual inductance in the matching network that needs to be resonated.

3.4 Parallel secondary capacitor vs. Series secondary capacitor

In section 3.2, the insertion loss equation was derived based on the assumption that the secondary capacitor is in parallel with the load R_L . However, the set of equations described in 3.2 hold true even for a series secondary capacitor. The starting step for such a configuration would be Fig. 3.5(b). The rest of the steps remain the same. The choice of series secondary capacitor versus a parallel secondary capacitor depends on the application of the system where the matching network is employed. If a series secondary capacitor is chosen, since the value of secondary winding's ESR R_2 compares directly with R_L (as can be seen in Fig. 3.5(b)), the loss due to R_2 remains constant irrespective of the value of series capacitor C_2 chosen. Hence the value of C_2 can be chosen so as to minimize the loss that arises due to the primary winding's ESR R_1 . In configurations which have parallel secondary capacitors, the value of C_2 cannot be

made too large or too small as it would increase the loss in either R_2 or R_1 respectively. This places a trade-off constraint on the selection of C_2 . However, in configurations which have series secondary capacitors, since the loss in R_2 is independent of C_2 , the value of C_2 can be chosen to minimize the loss in R_1 . This helps to make the insertion loss minimal over wide band of frequencies in a series-secondary capacitor configuration. Therefore, in applications where insertion loss needs to be made minimum over wide band of frequencies, series-secondary capacitors are preferred. On the other hand, if the application requires the matching network to be narrow-band so as to reject out-of-band signals, then parallel-secondary-capacitor configurations are preferred.

To illustrate the points mentioned above, the transformer that was used for the validation of the transformer model in section 3.3 is simulated with parallel and series secondary capacitors, respectively. The insertion loss plots for these two cases are shown in Fig. 3.7. From the figure, it is seen that the parallel-secondary capacitor configuration gives a minimum insertion loss of 1.2dB at 2GHz and the loss increases as the frequency of operation deviates from 2GHz. However, in series-secondary capacitor configuration, the insertion loss at 2GHz is 1.3dB and the loss decreases as the frequency of operation is increased. The minimum loss is 0.8dB for frequencies greater than 4GHz. This shows clearly that the series-secondary capacitor configuration is well-suited for applications requiring wide-band operation for a given transformer while the parallel-secondary capacitor configuration works well if narrow-band operation is desired.

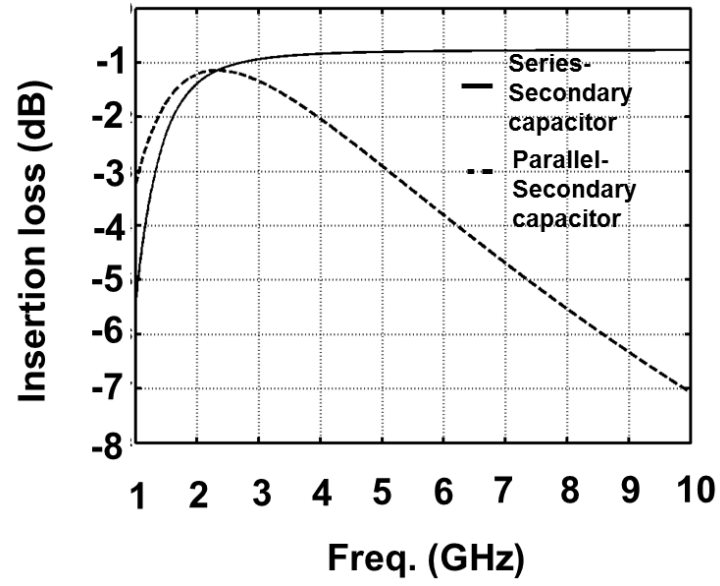

Fig. 3.7 Plot of insertion loss Vs. freq. in a transformer with series/parallel secondary capacitors

4. Tunable Matching Network Design

In order to fulfill the multi-standard and multi-mode demands of the ever-growing mobile device market (cellphones, laptops, tablets), current implementations contain an array of on-board duplexers and matching networks to interface the antenna with multiple RFIC transceiver chips. The goal of eliminating multiple off-chip matching networks, while supporting multi-standard communication provides a huge motivation to build fully-integrated tunable matching networks.

Two key parameters which characterize matching networks at the chip-boundaries are the impedance transformation-ratio (N), and the resonant frequency (ω_R) at which the transformation ratio N is valid. Furthermore, this leads us to identify two forms of tunability: *frequency-tunability*, and *impedance-tunability*. In this chapter, the design of a fixed-frequency, *impedance-tunable* matching network is described.

Traditionally, the matching network is optimized for low-insertion loss at a fixed ω_R , and a fixed transformation-ratio, N . Therefore, any tunability-algorithm must account for the variation in insertion-loss across the tuning range. This makes tuning network design which aims at achieving wide tuning ratios, on the order of 1:5 or 1:10, quite challenging. In chapter 3, the advantage of a transformer-based approach for the design of a large impedance transformation-ratio matching network was described. Extending on that foundation, two tunable matching networks have been realized using transformers along with L- and Pi-matched circuits, respectively. The transformer in the tunable networks steps-down the 50Ω antenna impedance to

a fixed lower value and the L-or Pi-matched network converts this fixed value impedance resulting from the transformer to variable input impedance.

Fig. 4.1 describes the tunable matching network implemented in this work. The transformer portion of the network, consisting of L_1 , R_1 , L_2 , R_2 , C_2 and R_L , forms the fixed impedance transformation block while the L-match or Pi-match forms the variable impedance transformation block. Impedance tunability in the L/Pi-network is achieved with tunable capacitor banks.

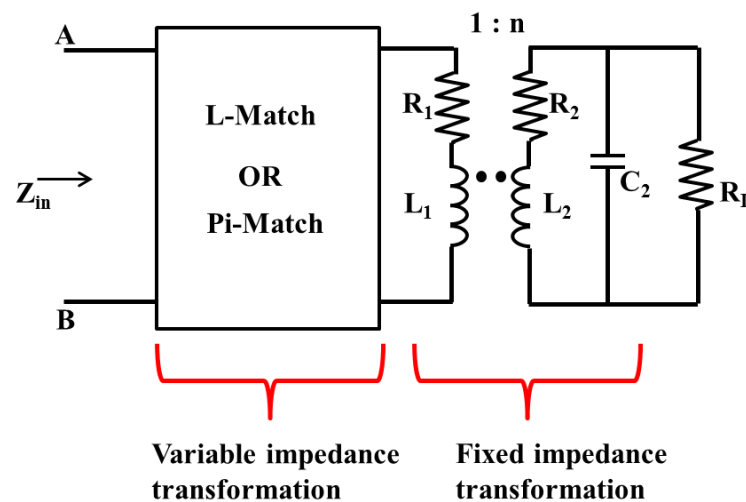

Fig. 4.1 Tunable Matching network implemented with transformer and L/Pi- network

Theoretically, it is possible to achieve impedance tuning by modulating the secondary capacitor C_2 of the transformer. However, as described in chapter-3, the efficiency and insertion loss of transformer is a strong function of C_2 . Thus, C_2 is selected with the goal of optimizing the transformer insertion-loss only, and is not used for obtaining tunability.

From a reliability perspective, there is an additional benefit of using a transformer to step-down the impedance prior to the variable L/Pi matching network. For a transformer with a 1:n turns-ratio, the n^2 reduction in impedance is accompanied by a factor of “n” *step-down* in

voltage swing on the primary side as compared to the secondary. Thus, CMOS switches used in tunable L/Pi-match sections (in the capacitor banks), are subjected to lower voltage swings across the drain-to-gate and drain-to-bulk terminals. It is also important to note that the capacitance C_2 must sustain the same voltage swing as seen by the antenna, across its terminals. For a PA generating 30dBm of output power, this swing could be as large as 10V. This precludes any attempt to add a switch-capacitor bank to vary the value of C_2 and obtain tunability.

The design and implementation details of the two tunable networks, transformer-plus-L-matched network (TLMN) and transformer-plus-Pi-matched network (TPMN), are discussed in sections 4.1 and 4.2 respectively. The two tuning networks are designed to absorb the fixed output capacitance of the PA into the matching network, while presenting the PA with input impedance Z_{in} , which is real and variable. Hence, in both TLMN and TPMN, two sets of capacitors are varied using switch-capacitor banks. While one of the capacitors tunes the real-part of the impedance Z_{in} , the other capacitor is necessary to maintain the imaginary part of Z_{in} at a constant value. In systems which need to correct the AM-PM conversion induced non-linearity, it is possible to extend the proposed tuning structure to enable independent control over the imaginary part of the impedance Z_{in} as well [29], [30].

4.1 Transformer-plus-L-match-based tunable Matching Network (TLMN)

The circuit schematic for the TLMN is shown in Fig. 4.2. The finite quality factor transformer comprises of inductors L_1 , L_2 and resistors R_1 , R_2 . The variable L-match is implemented with inductor L_3 , and switch-capacitor banks C_{var} and C_{par} . The real-part of the input impedance Z_{in} , of the TLMN, can be varied using C_{var} . The capacitor bank C_{par} is used to

compensate for the variation in imaginary-part of Z_{in} , which is the resultant of a variable C_{var} . The matching network has been designed for a center frequency of 2GHz.

4.1.1 Design details

In order to demonstrate impedance tunability for large transformation ratios, the prototype test chip is designed using a transformer with turns-ratio $n \approx 2$. A stacked-transformer has been implemented using the ultra-thick metal layer (UTM) and Aluminum passivation layer (AP). The transformer is characterized through a 3-D electromagnetic simulation using Ansoft's HFSS. The self-inductance of the primary and secondary windings of the transformer is determined to be 362pH and 1.25nH, respectively, resulting in a transformation ratio of approximately 1:1.86. The ESRs of primary and secondary inductances are $R_1=0.7\Omega$ and $R_2=1.87\Omega$ and the coupling co-efficient, $k_m=0.65$. The secondary capacitor C_2 is selected using the minimum insertion loss criteria derived in section 3.2. At the operating frequency of 2GHz, a secondary capacitance of 3.9pF results in a minimum insertion loss of 1.9dB.

The variable capacitors in the tunable network, C_{var} and C_{par} , are realized using switch-capacitor banks as shown in Fig. 4.2. The capacitors in this network are implemented using MOM-capacitors as these capacitors are significantly more linear than a junction-based varactor diode, hence producing lower distortion products [31].

Ideally, ON/OFF switches in series with a capacitor, should be sized to minimize the ON resistance and hence, the insertion loss. However, increasing the switch size to reduce the ON resistance will result in increased parasitic capacitances associated with the switch. The parasitic capacitances of the switch will constrain the minimum C_{var} and C_{par} values that can be realized, which in turn will limit the tuning range.

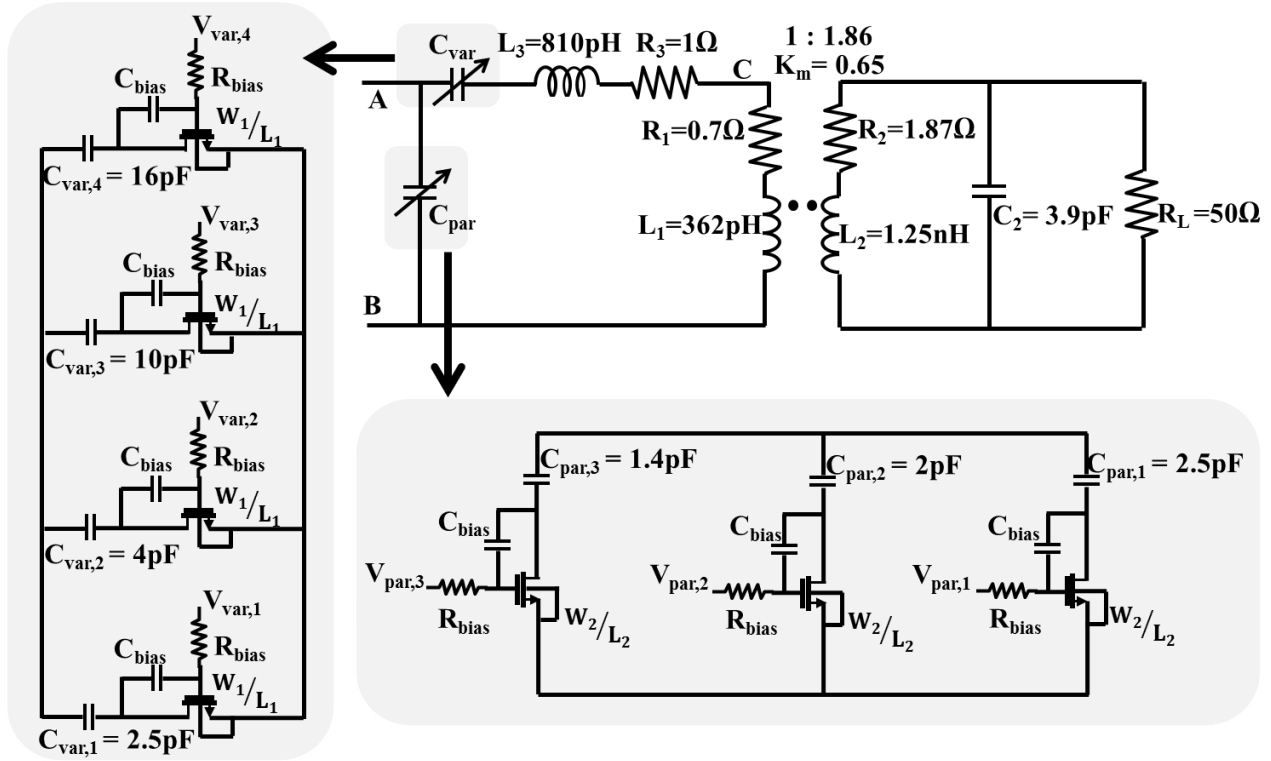

Fig. 4.2 Circuit implementation of Transformer-plus-L-match-based tunable network (TLMN)

Considering this trade-off between loss and tuning range, for the switch capacitor bank C_{var} , a deep n-well NMOS switch with a width of 2mm and length of 40nm is used in this design. At $f_0=2\text{GHz}$, the ON resistance of the switch is 0.85Ω .

The switch in the capacitor bank C_{var} is in series with the inductor L_3 . Therefore, a larger ON resistance of the switch will result in lower quality factor for the series arm consisting of inductor L_3 and the switch. At radio frequencies, the quality factor of an inductor is usually the more critical parameter than the capacitor. Hence, the ON resistance of the switch in the C_{var} capacitor bank, which decides the net quality factor of the inductor L_3 , needs to be smaller when compared to the switch in the C_{par} capacitor bank. Considering the above mentioned factors, for the switches in C_{par} , a size of 200um/40nm was selected, which gives an ON resistance of 8.5Ω at f_0 .

A $10\text{K}\Omega$ resistor, R_{bias} , is used to bias the gate of the NMOS switches in C_{var} and C_{par} , and thus provide high impedance for AC signals. The high impedance at the gate of the series-switch transistor in C_{var} bank allows bootstrapping the voltage swing on the source/drain onto the gate. The signal coupled to the gate through C_{bias} eliminates large voltage swing across the gate-to-source terminals of the NMOS and improves the reliability of the circuit. The digital signals $V_{\text{var}1,2,3}$ and $V_{\text{par}1,2,3}$ control the state of the switch-capacitor bank. The control signals operate at an ON/OFF voltage of 1V and 0V, respectively. Inverter buffers are used to drive the signals on both V_{var} and V_{par} .

To illustrate the impact of various resistive and capacitive parasitics on the impedance tuning range, the transformer in the TLMN circuit has been simplified and the schematic for the same is shown in Fig. 4.3. The transformer, consisting of L_1 , R_1 , L_2 , R_2 , C_2 and R_L , is now represented as an equivalent inductor, L_{xfrm} in series with a resistor, R_{xfrm} . The values of L_{xfrm} and R_{xfrm} are calculated using the simplification steps described in section 3.2, Fig. 3.5. At the center frequency of 2GHz, $L_{\text{xfrm}}=410\text{pH}$ and $R_{\text{xfrm}}=4\Omega$ for the prototype TLMN circuit.

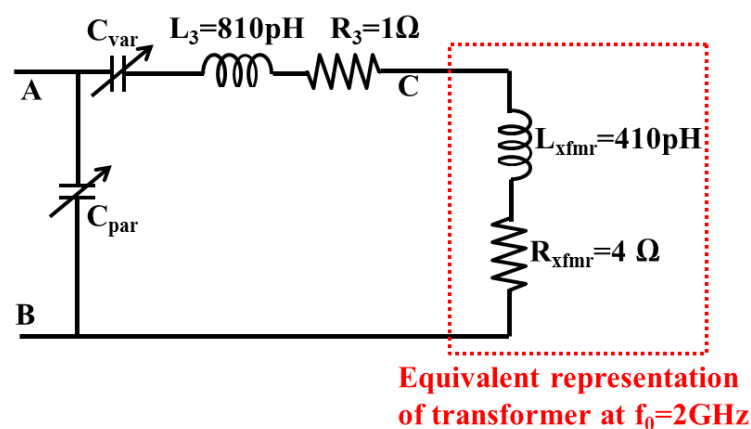

Fig. 4.3 Simplified representation of the TLMN

The simplified network indicates that the transformer has stepped-down the 50Ω antenna

impedance to R_{xfmr} of 4Ω . The goal is to study the range of input impedance (Z_{in}) that can be obtained with a variable L-match, which is discussed in the next section.

4.1.2 Tuning Range Limitations using an L-match

From a circuit-theory perspective, there is no upper-bound on the impedance that can be obtained from a tunable L-match made of ideal L and C components. However, for a practical physical implementation of the TLMN in integrated-circuit form, it is important to analyze the impact of three non-idealities. First, inductors have a finite quality factor of less than 10 or 12 at radio frequencies. Second, the parallel-plate capacitors have parasitic bottom-plate capacitance which can be 5-10% of the desired capacitance. Finally, any switch implementation using MOS transistors must account for the fundamental trade-off between channel resistance in the ON state and parasitic capacitance in the OFF state.

Upper Bound on Z_{in} :

In Fig. 4.3, L_3 , L_{xfmr} , R_3 and R_{xfmr} form a series R-L circuit with the quality factor of the branch given as -

$$Q_{ser} = \frac{\omega_0(L_3 + L_{xfmr})}{(R_3 + R_{xfmr})}$$

The purpose of C_{var} in the L-match network is to modify the effective value of inductance L_3 . Hence, if we consider the inductance L_3 to be variable (achieved by varying C_{var}), the resultant impedance Z_{in} , between nodes A and B, will be

$$\text{Real}(Z_{in}) = (R_{xfmr} + R_3) * (1 + Q_{ser}^2)$$

where, Q_{ser} is variable and is determined by the variable inductance L_3 . From the expression for Z_{in} , it is obvious that higher values of input impedance Z_{in} can be obtained by increasing the inductance L_3 . However, assuming a constant quality factor, it is straight-forward to prove that

an increase in L_3 is also accompanied by a corresponding increase in the ESR, R_3 . From Fig. 4.3, R_3 appears in series with $R_{x_{fmr}}$. An increase in R_3 results in an increased insertion loss in the TLMN. Thus, an upper bound on L_3 is determined based on the maximum insertion loss tolerable. And this maximum value of L_3 places an upper bound on input impedance Z_{in} .

The next component to consider is the series capacitance C_{var} . C_{var} is employed in the L-match network to provide variable inductance L_3 (by tuning the values of C_{var}). Thus, the value of C_{var} will determine the effective value of L_3 in the network indicated in Fig. 4.3. As explained in the above paragraph, higher the value of effective L_3 , higher will be the input impedance Z_{in} . Therefore, a large capacitance value for C_{var} will result in an increase in the effective inductance L_3 , which in turn will lead to higher values for Z_{in} . In order to illustrate this point, an example is considered which is explained with the help of Fig. 4.4. Let the inductance L_3 have a fixed value of 810pH. Consider two different values of C_{var} , say $C_{var}=10\text{pF}$ and $C_{var}=30\text{pF}$. As seen from the two circuits in Fig. 4.4, corresponding to two different values of C_{var} , the circuit with higher value for C_{var} , i.e. $C_{var}=30\text{pF}$, results in a higher impedance for Z_{in} . However, the C_{par} capacitance required to resonate out the imaginary part is lower too in such a case.

The capacitance C_{var} is implemented using a metal-oxide-metal (MOM) parallel plate capacitor. The parasitic capacitance ($C_{parasitic_MOM}$) on the bottom-plate makes the capacitor an asymmetric device. This parasitic capacitance can be absorbed into the C_{par} capacitor bank such that $C_{par} = C_{par_variable} + C_{parasitic_MOM} + C_{PA}$ where $C_{par_variable}$ is the variable capacitance implemented using switch-capacitor bank and C_{PA} is the output capacitance of the PA stage. Since, $C_{parasitic_MOM}$ is directly proportional to the value of C_{var} , higher values of capacitance C_{var} will result in large parasitic bottom-plate capacitance. It is important to note that absorbing the

fixed capacitance $C_{\text{parasitic_MOM}}$ into C_{par} reduces the variable component of $C_{\text{par_variable}}$. Therefore, there exists an upper bound on the value of C_{var} than can be realized in the TLMN.

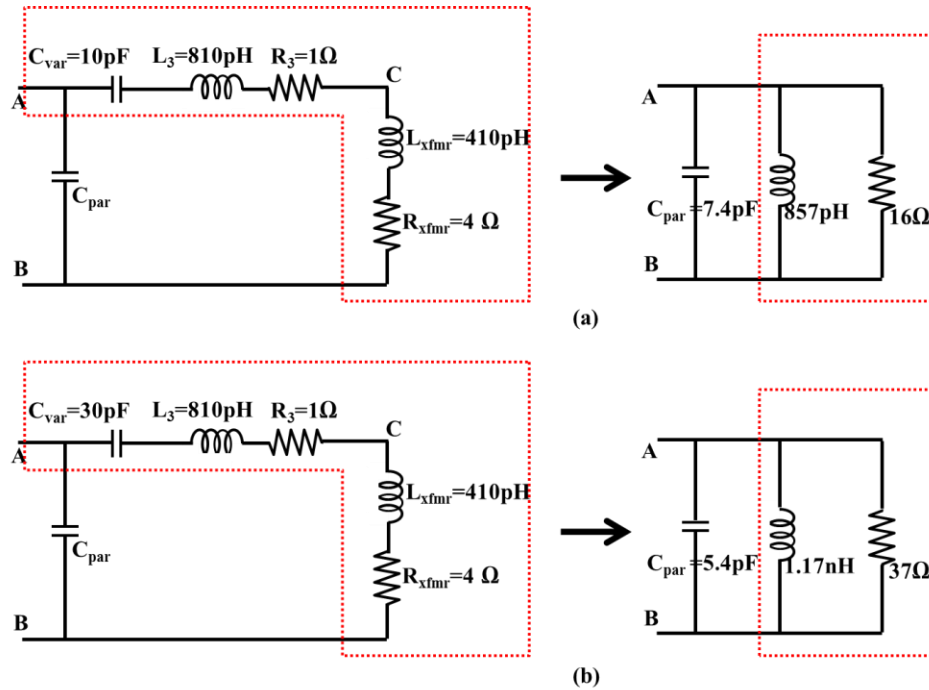

Fig. 4.4 Illustration of tuning range limitation due to C_{var} and C_{par} values

The third limitation on the upper bound of Z_{in} arises from the MOS implementation of the switches which is illustrated in Fig. 4.5. When the MOS switch is ON, the switch-capacitor arm can be modeled as a capacitor in series with the ON resistance, which can be represented in the parallel form as $C_{\text{par}}' \parallel R_{\text{on}}'$. In section 4.1.1, the fundamental trade-off that exists between the switch ON resistance and the parasitic capacitance was described. The switch in series with C_{par} is sized such that the parasitic capacitance arising due to the OFF switch doesn't limit the minimum C_{par} that can be realized. However, this constrains the minimum ON resistance that can be obtained when the switch is ON, resulting in a finite value of R_{on}' in the parallel representation. As the value of Z_{in} increases, the loss due to R_{on}' (or the switch in the parallel

capacitor bank C_{par}) increases, resulting in an increased insertion loss in the network. Thus, there is a trade-off between the insertion loss and upper bound on Z_{in} that can be obtained.

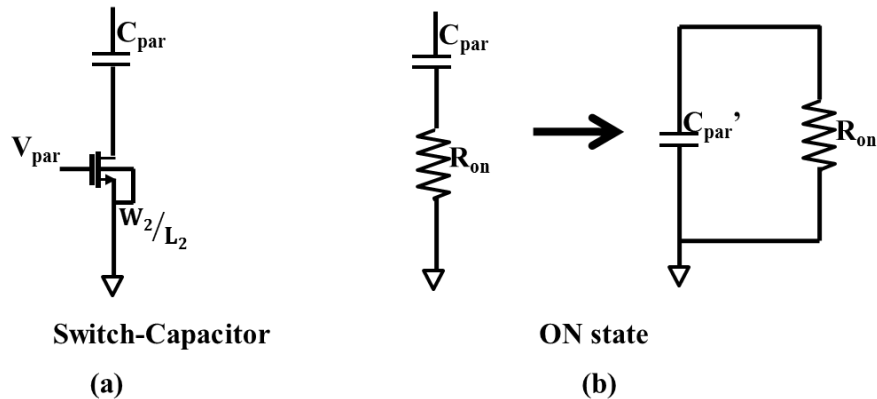

Fig. 4.5 (a) Switch-capacitor branch (b) Equivalent circuit when the switch is in 'ON' state

Lower Bound on Z_{in} :

The lower range of impedance obtainable is limited by two factors- transformer turns ratio and the parasitic capacitance in C_{var} bank. The L-match networks can only step-up the impedance that results from the fixed impedance translation from the transformer. The lower bound on Z_{in} is thus equal to R_{xfrm} (refer to Fig. 4.3). In the previous section, it was shown that higher values of C_{var} will result in higher values of Z_{in} . Therefore, to obtain lower values of Z_{in} , the value of C_{var} should be smaller. The dependence of the lower bound on C_{var} 's parasitic capacitance can be better illustrated with the help of Fig. 4.6. Assume C_1 , C_2 and the series switches constitute a switch-capacitor bank. The OFF NMOS transistor is modeled as a capacitance, C_{drain} , as shown in Fig. 4.6(b). When a switch is OFF, ideally it should provide an open-circuit, or infinite impedance condition. However, due to parasitic capacitance C_{drain} , the OFF switch provides an input capacitance of $(C_1 \text{ series } C_{\text{drain}}) \parallel (C_2 \text{ series } C_{\text{drain}})$. Thus, in the C_{var} and C_{par} capacitor banks, the OFF transistor's parasitic capacitor limits the minimum

achievable capacitance value.

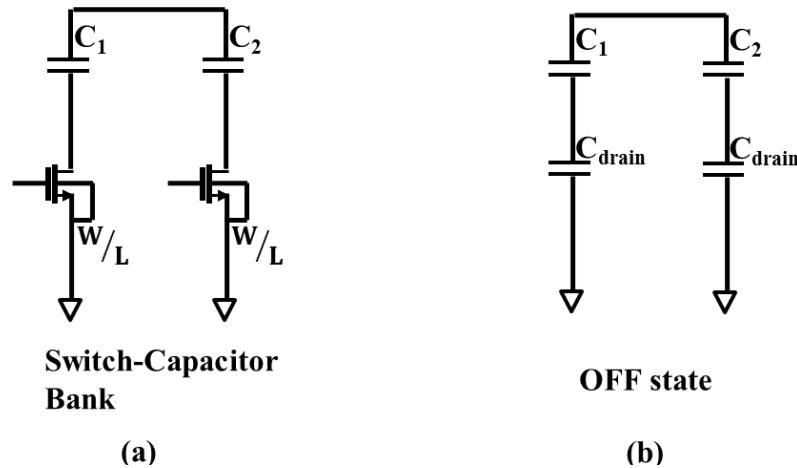

Fig. 4.6 (a) Switch-Capacitor Bank (b) Equivalent circuit when the switches are ‘OFF’

Considering the above mentioned trade-off, values of C_{var} , C_{par} and L_3 have been chosen to optimize both the tuning range and insertion loss. A tuning range of 1:4.8 has been obtained using the TLMN. The loss in the transformer is 1.9dB. The switches and the ESR of L_3 introduce an additional loss of 1.5dB, resulting in a total loss of 3.4dB in the TLMN. In the next section, design of the second tunable matching network namely, Transformer-plus-Pi-match-based tunable matching network (TPMN) is discussed.

4.2 Transformer-plus-Pi-match-based tunable Matching Network (TPMN)

In TPMN described in Fig. 4.7, the Pi-matching network provides impedance tunability. Similar to the TLMN, the transformer steps-down the 50Ω antenna impedance to lower valued impedance. The pi-network converts the fixed impedance resulting from the transformer network to variable impedance by tuning the capacitor values in C_{par} and C_{var} capacitor banks.

4.2.1 Design details

The transformer used in the TLMN, described in sub-section 4.1, is also used in the

design of the TPMN. The fixed inductance L_3 and the variable capacitors, C_{var} and C_{par} , together form a Pi-network. The variable capacitors are realized using switch-capacitor banks where the switches are turned ON or OFF using digital control signals $V_{par,1,2,3}$ & $V_{var,1,2,3}$. The NMOS switch control voltages are 1V and 0V in both the capacitor banks. The switch-size W_1/L_1 in the capacitor bank C_{var} is 2.5mm/40n and the switch size W_2/L_2 in the capacitor bank C_{par} is 2mm/40n. These switch sizes are chosen to minimize the losses without increasing the parasitic capacitance (explained in detail in section 4.2.2). Similar to the TLMN, R_{bias} and C_{bias} are used to setup DC bias voltages for the NMOS switches and couple AC signal swing onto their gates. Inverter buffers are used to drive both sets of switches. A value of 444pH is selected for inductance L_3 considering the tuning range versus insertion loss trade-off, which will be explained in the next section (4.2.2)

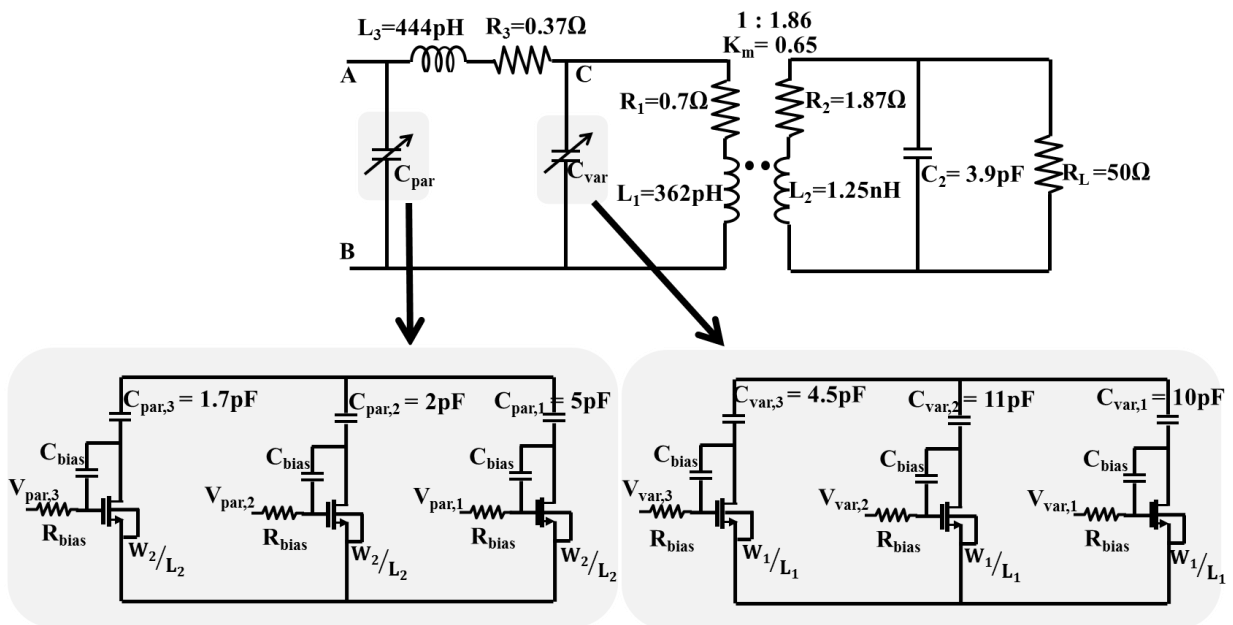

Fig. 4.7 Circuit implementation of Transformer-plus-Pi-match-based tunable network (TPMN)

The transformer network formed by the components L_1 , L_2 , R_1 , R_2 , C_2 and R_L can be simplified into an equivalent inductance and resistance by following the steps described in section 3.2, Fig. 3.5. However, in contrast to section 4.1.1, the equivalent inductance and resistance are represented as a parallel network, ($L_{\text{xfmr}}' || R_{\text{xfmr}}'$), as shown in Fig. 4.8. Parallel representation was chosen over series representation for the sake of convenience to simplify the Pi-network.

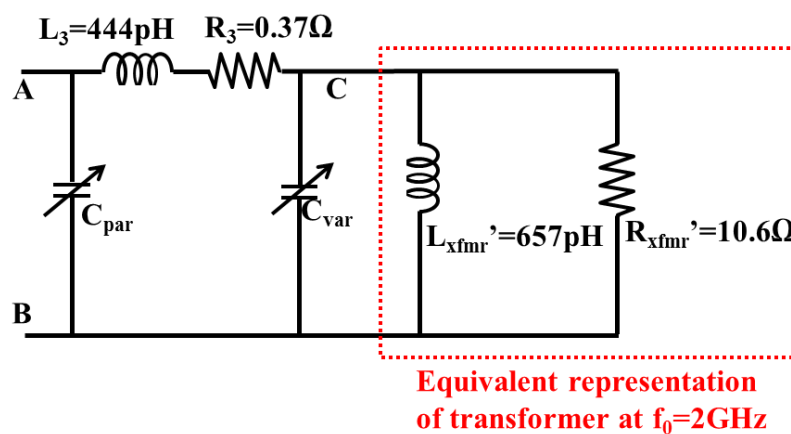

Fig. 4.8 Simplified representation of the TPMN

4.2.2 Tuning Range Limitations using a Pi-match

The design of the TPMN involves selecting values for L_3 , C_{var} , and C_{par} which simultaneously maximize the tuning range and minimize the insertion loss. However, once the non-ideal effects of the circuit components are considered, a closed-form optimization criterion is difficult to derive. Hence, an empirical design approach, which highlights the trade-offs involved in the choice of L_3 , C_{var} and C_{par} , is described next. The tuning range limitation of the TPMN is described with the assistance of the plots in Fig. 4.9(a)-(c).

The characteristics of the TPMN are plotted as a function of the variable capacitance C_{var} .

First, the variation of the real part of the input impedance Z_{in} i.e. $\left[\frac{1}{\text{real}(Y_{\text{in}})} \right]$ is plotted in Fig.

4.9(a). Next, the value of C_{par} required to maintain resonance at the operating frequency of 2GHz, as a function of variable C_{var} , is plotted in Fig. 4.9(b). Finally, the insertion loss of the TPMN as a function of C_{var} is plotted in Fig. 4.9(c). All the graphs in Fig. 4.9(a)-(c) have been plotted for four different values of L_3 , 200pH, 400pH, 800pH and 1500pH. A Q-factor of 10 has been assumed for L_3 in each case.

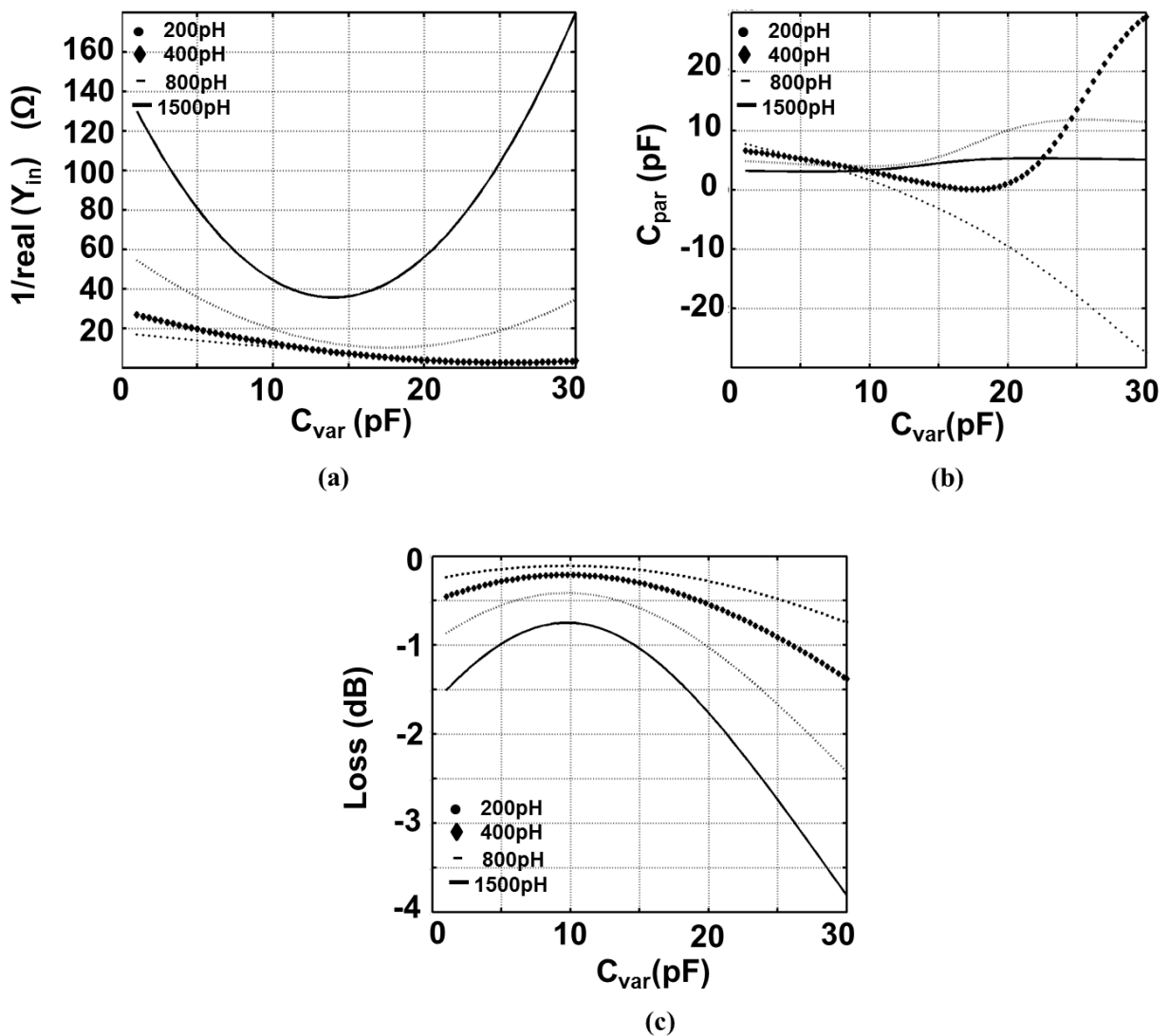

Fig. 4.9 Tuning Range Limitation in the TPMN: Plot of (a) Real (Z_{in}) Vs. C_{var} (b) C_{par} required to resonate the imaginary part of Y_{in} Vs. C_{var} (c) Insertion Loss Vs. C_{var} – for different values of L_3

Starting with the minimum inductance value, $L_3=200\text{pH}$, from plot (a), it would appear that a C_{var} variation of 0.1pF to 30pF yields a Z_{in} variation from 2Ω to 18Ω . However, from Fig. 4.9(b), for values of C_{var} larger than 12pF, C_{par} is negative. Thus, with $L_3=200\text{pH}$, the entire range of C_{var} (0-30pF) cannot be utilized.

Next, consider the case in which the inductance L_3 is 1500pH. From plot (a) in Fig. 4.9, it can be observed that maximum Real (Z_{in}) of 90-140 Ω can be obtained at the high end. However, this is accompanied by a corresponding increase in the minimum Real (Z_{in}) which limits the impedance tunability to a ratio of 1:3. More importantly, from Fig. 4.9(c), the TPMN suffers from higher insertion loss as the value of L_3 increases.

In summary, to obtain a large Z_{in} , a large L_3 is required. However, large values of L_3 result in high insertion loss. To realize smaller values for Z_{in} , a smaller L_3 is required. But for small values of L_3 , as C_{var} increases, the C_{par} required to resonate the residual imaginary part becomes negative, meaning that a parallel inductor is required instead of a capacitor.

The value of L_3 is thus chosen based on the range of Z_{in} desired from the TPMN and the specification of the insertion loss. Once L_3 is chosen, the tuning range limitations come from the range of C_{var} and C_{par} that can be implemented using switch-capacitor banks (discussed in section 4.1.2, Fig. 4.6). Hence, the tuning range in this structure is limited by L_3 value and minimum C_{var} and C_{par} capacitor values that can be realized. Also, there is a trade-off between the maximum value of Z_{in} and minimum value of Z_{in} versus the network insertion loss (similar to the TLMN structure).

To achieve a tuning range of 1:5.5, while maintaining an insertion loss of less than 2.3dB, an inductance of 440pH was selected for the TPMN. The switches in the parallel capacitor banks

and ESR of L_3 introduce 0.5dB loss while the transformer introduces 1.9dB loss.

4.3 Comparison between TLMN and TPMN

Transformer-plus-Pi-matched structure (TPMN) has several advantages when compared to Transformer-plus-L-matched structure (TLMN).

- a. DC-Bias functionality: The TLMN contains a series capacitor in the signal path. As a result, in a fully-integrated differential PA system, the center-tap of the transformer in the TLMN cannot be used to provide the supply bias. A separate DC choke inductance has to be included in the PA for providing supply voltage. On the contrary, the TPMN does not contain any series capacitance and does not need any additional bias inductance.
- b. ON-resistance of the switch: In the TPMN, the switches in both the C_{var} and C_{par} capacitor banks are shunt switches with one terminal connected to the ground. With a grounded source, the NMOS transistors are fully turned on independent of the input signal level. In addition, there is no signal swing at the drain of the NMOS switch when it is ON. This leads to constant switch resistance ensuring better linearity [15]. In contrast, the switches for C_{var} bank in the TLMN are in the signal path and have large voltage swings at both the drain and source nodes of the NMOS. Though a coupling capacitor is added between the source and gate nodes of the NMOS switch, to keep the switch ON at all signal levels, the value of the ON resistance varies depending on the input signal strength. The ON resistance is also sensitive to the parasitics occurring at the switch's source/drain and gate nodes. Thus, the linearity of the TLMN is not as good as the TPMN.

- c. Robustness of the network: The series switches in the TLMN pose another serious problem. In the series switches in C_{var} block, the bulk of the NMOS switch is locally connected to its source. This is done with the intention of eliminating threshold voltage increase due to different potentials at source and bulk terminals. Due to the locally shorted bulk, the deep-nwell associated with the NMOS switch necessitates a layout as shown in Fig. 4.11. There are two p-n junctions between the source/bulk and p-substrate (ground) terminals which results in two diodes, a pwell-to-deep nwell diode and a deep nwell-to-psub diode, in anti-series configuration as shown in Fig. 4.11. These diodes create depletion capacitance between the source and ground nodes. This capacitance is modeled as the unwanted capacitance C_{unwanted} , indicated between nodes C and B in Fig. 4.10 (highlighted in red). The unwanted capacitance between nodes C and B alters the value of the input impedance Z_{in} . Therefore, it is necessary to account for this capacitance while designing the TLMN (Even if the bulk is not shorted to ground, the source-to-bulk capacitance has the same undesired effect as described above). The TPMN, on the other hand, is transparent to this C_{unwanted} capacitance (occurring between the drain/source of the switch and substrate), as the capacitance gets shorted out by the ON resistance of the switch. Hence, the TPMN is more robust to parasitics arising due to the internal diodes in NMOS switches.

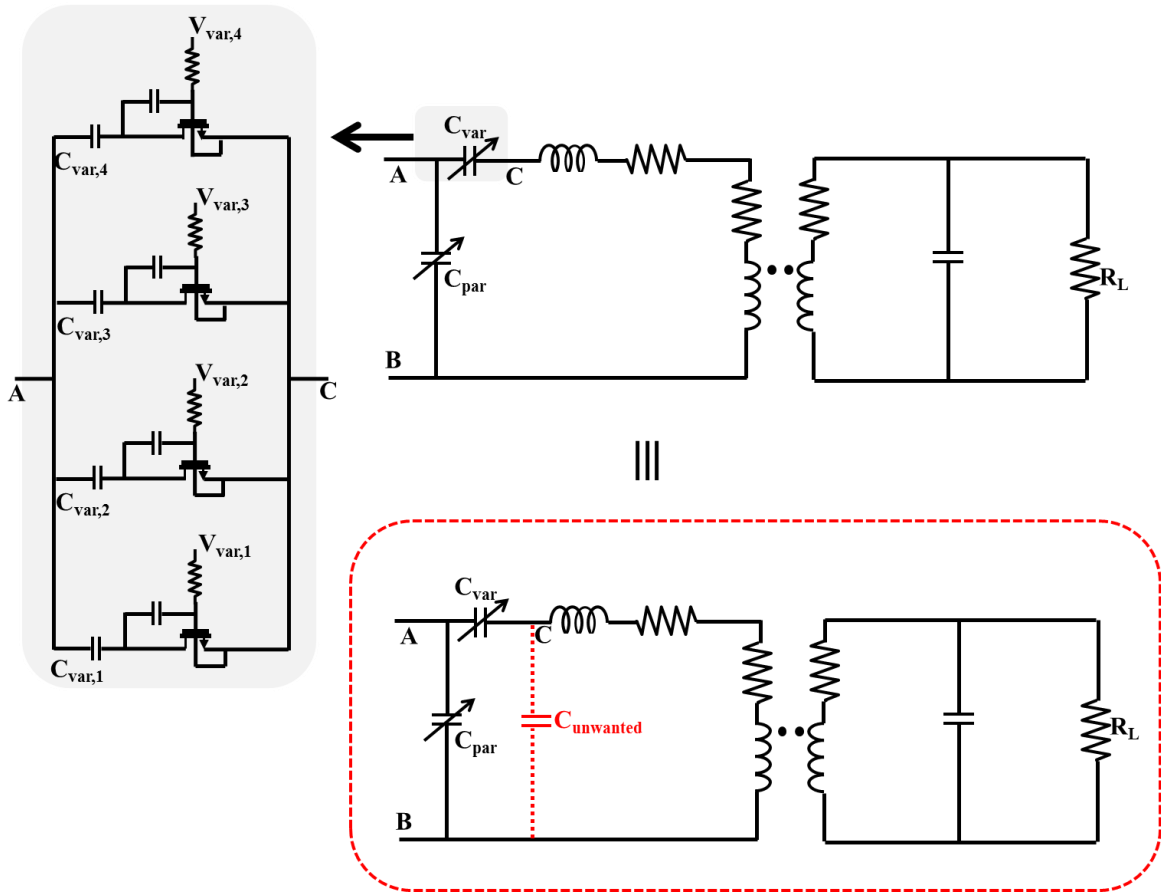

Fig. 4.10 Limitation in the TLMN due to parasitic capacitances

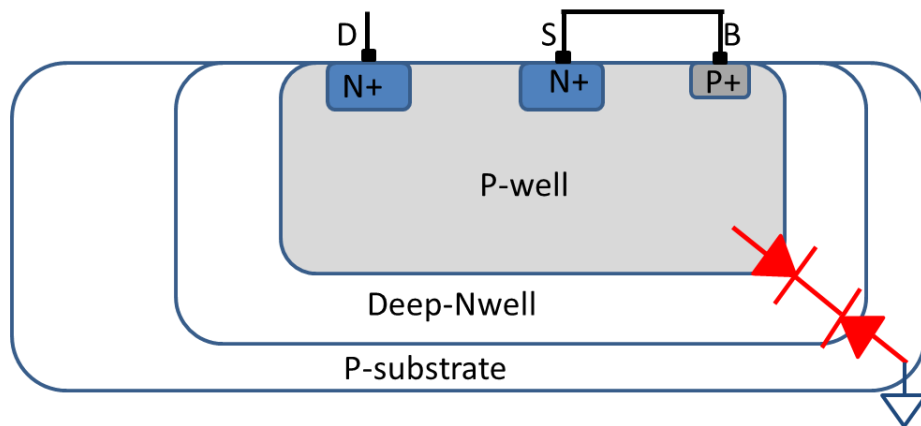

Fig. 4.11 Cross-section of a NMOS transistor in deep n-well

In summary, by using a set of switch-capacitor banks to realize a variable capacitance, two tunable matching networks have been implemented in bulk-CMOS process. The two networks have a 100MHz bandwidth of operation, with a center frequency around 2GHz. Since the control voltages for all the switches are 1V, the tuning networks are ideal for integration with lower sub-nanometer CMOS process nodes where the supply voltages are limited to 1V or 1.2V. The transformer in the tunable matching network has been designed for minimum insertion loss while the L/Pi-networks have been optimized for both tuning range as well as insertion loss. The variable capacitors in this work are selected to obtain real impedance Z_{in} for all switch settings while maintaining the imaginary part of the impedance at 0Ω . However, a variable imaginary part can be obtained as well, by aptly varying the capacitors in the switch-capacitor banks. The two matching networks are ideal for use as PA output matching network where a variable R_{out} needs to be presented to the PA. The concepts described in this chapter and the tunable networks developed can be used for other applications as well by tailoring the networks to meet the specific demands of the application.

In the next chapter, simulation results for the two tunable matching networks are presented.

5. Simulation Results

In this chapter, simulation results for TLMN and TPMN are presented. The two tuning structures were designed in 40nm CMOS process using a 6-layer metal stack. The transformer was built using the two low-resistivity metal layers available in the stack: M6, the ultra-thick-metal (UTM) made of copper, and AP, the Aluminum Passivation metal. The layout of the two structures, TLMN and TPMN, is shown in Fig. 5.1. The area of each tuning structure is approximately 0.47mm^2 .

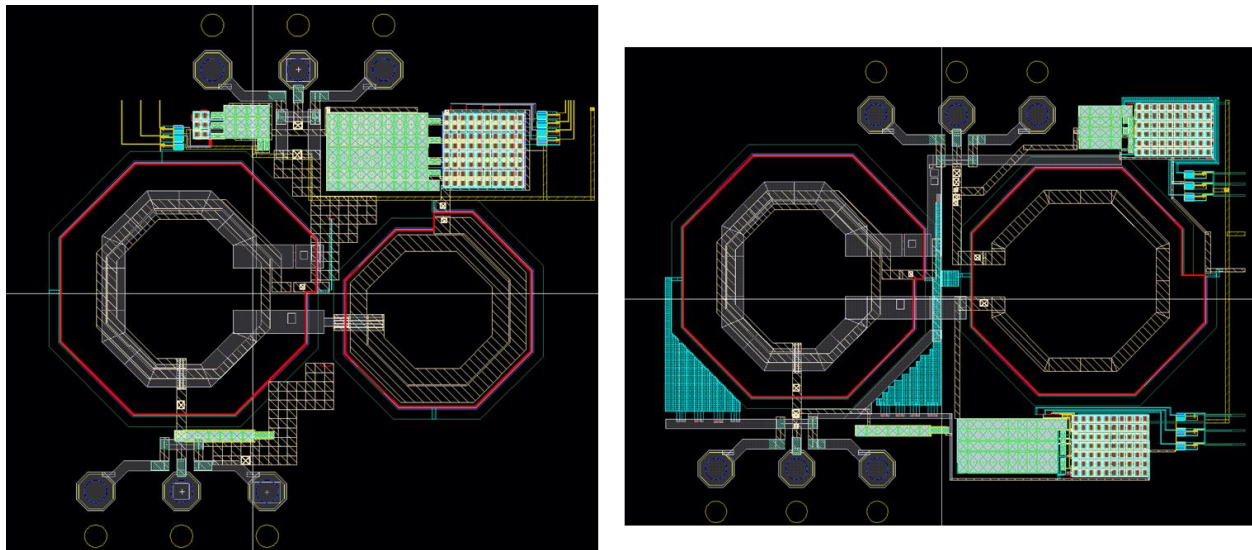

Fig. 5.1 Layout of (a) TLMN (b) TPMN

The transformers and inductors used in the tuning networks were characterized by EM simulations in HFSS. Since both the networks are implemented as single-ended structures, GSG probe pads are added on the input and output side for wafer probing. The power supply, ground, and digital control-bits are brought off-chip via wire-bonded pads. A serial shift-register based test interface is used to control the ON/OFF state of the switches in the capacitor bank.

The tuning networks described in this section have application between the PA output and the antenna. Therefore, the main parameter of interest is the range of real input impedance that can be realized while maintaining a zero imaginary part. Another possible application of the tunable matching network techniques proposed in this work would be for dynamic load modulation for efficiency improvement. In such a system, the impedance presented to the PA is modulated as a function of the input signal strength to maintain PA operation at peak efficiency. Variation in the phase of S_{21} , resulting due to impedance tuning, translates to a signal dependent phase delay, resulting in inter-symbol interference (ISI) [14]. Hence, if dynamic load modulation is desired, the variation in the phase of S_{21} should be as low as possible. For high power application, it is important that the tuning network does not limit the compression point of the PA. The next two sections provide the performance of the two networks in the areas discussed above. Both these networks are characterized with a 50Ω load to mimic the effect of the antenna impedance.

5.1 Simulation results of the TLMN

The TLMN impedance tuning network comprises of a 4-bit capacitor bank along the series path, and 3-bit capacitor bank in the shunt path. Seven independent bit settings yield 2^7 unique input impedance (Z_{in}) values. However, as described previously, at the output of the PA it is important to modulate the real-part of the input impedance with minimal variation in the imaginary part. The magnitude and phase of the input impedance for four states of the TLMN which yields very small $\text{imag}(Z_{in})$ are plotted in Fig. 5.2. The magnitude, and phase of Z_{in} versus frequency is shown in Fig. 5.2(a) and Fig. 5.2(b), respectively.

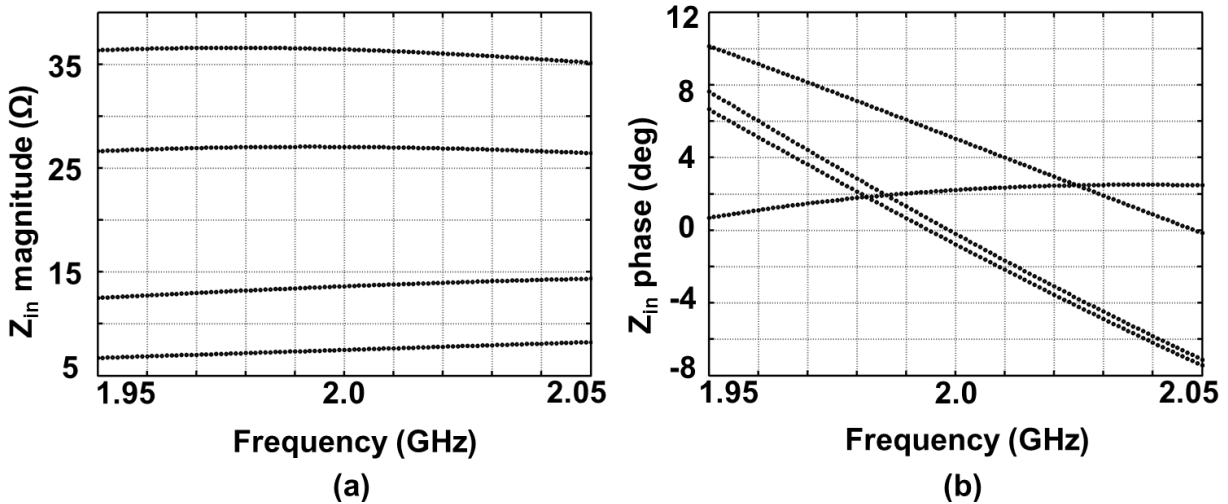

Fig. 5.2 Plot of $|Z_{in}|$ and phase (Z_{in}) Vs. frequency for different switch settings in the TLMN
 A total of four real Z_{in} values have been obtained using the TLMN structure, with a lowest value of 7.5 Ω and a highest of 36 Ω . The TLMN has a tuning range of 1:4.8 and the phase of the input impedance varies by less than 10 degrees over a bandwidth of 100MHz. Low phase variation as a function of frequency implies that the impedance transformation is broadband.

Z_{in} (Ω)	Simulation Results	
	Insertion Loss (dB)	S_{21} phase (deg.)
7.5	3.6	-12
14	3.6	-14
27	3.6	-32
36	3.5	-36

Table 5.1 Insertion Loss and phase of S_{21} across Z_{in} values in the TLMN

The insertion loss of a tuning network is an important parameter especially for PA output matching networks. The insertion loss as a function of $\text{Re}(Z_{in})$ is reported in Table 5.1. The 3.6dB loss of the TLMN network includes 1.9dB loss from the transformer, and 1.6dB loss from the series inductor and the switches. It is possible to reduce the insertion loss of the switches by

increasing the W/L ratio and thus reducing the switch resistance. However, the improved insertion loss is obtained at the expense of reduction in the tuning range due to increased parasitic capacitance. On the other hand, improving the Q-factors of the primary and secondary windings of the transformer will reduce the insertion loss without affecting the tuning range.

While it is important to maintain the phase of Z_{in} (related to the phase of S_{11}) at a fixed value across the frequency range of interest, it is also necessary to minimize the variation in phase of S_{21} across impedance settings. The 2nd column in Table 5.1 lists the phase values of S_{21} at different Z_{in} values. As seen in the table, the phase variation in S_{21} across the entire Z_{in} range is 24 degrees. As described in the earlier section, variation in phase of S_{21} as a function of Z_{in} will result in distortion in a dynamic impedance tuning network. However, if the tuning network is used in static applications where the impedance setting does not require a dynamical change based on the input power level, then the change in the S_{21} phase has minimal consequence.

For high power applications where the output node of the PA could see large voltage swings, the linearity performance of the tunable matching network becomes important. The passives in the tunable impedance network, namely the series inductor and transformer, do not contribute to linearity degradation. The metal-oxide-metal (MOM) capacitors are also linear over large voltage swings. The main sources of non-linearity are the active devices or switches used in the capacitor banks. A measure commonly used to assess the non-linearity in a power amplifier is the 1-dB compression point, P-1dB. It is defined as the point where the output power of the amplifier is 1dB below the level extrapolated from linear small-signal region.

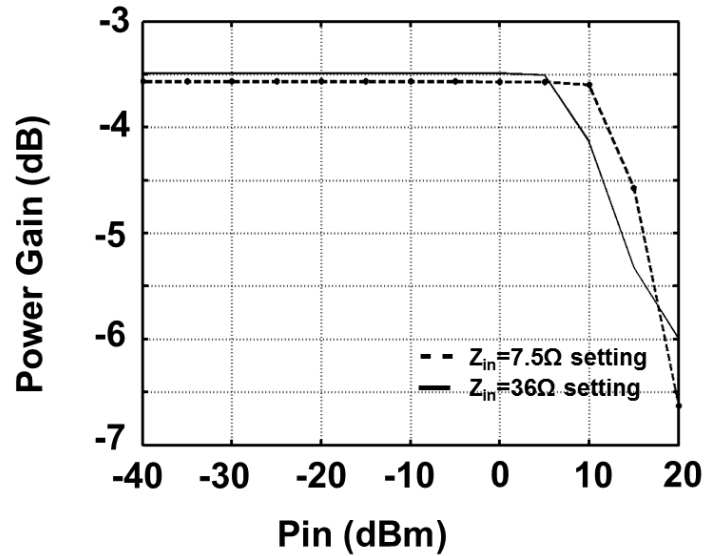

Fig. 5.3 Plot of Power gain as a function of input power in the TLMN

For the TLMN structure, the plot of power gain versus input power is shown in Fig. 5.3. When the switches are set to obtain a Z_{in} of 7.5Ω , the P-1dB is 15dBm and for the switch setting to obtain $Z_{in}=36\Omega$, P-1dB is 12 dBm.

5.2 Simulation results of the TPMN

The TPMN structure is comprised of two 3-bit capacitor banks in the shunt path and they tune the capacitors C_{var} and C_{par} . Six independent bit settings yield 2^6 unique values for Z_{in} . However, only those Z_{in} values that result in purely real impedances are plotted in Fig. 5.4. The magnitude, and phase of Z_{in} versus frequency is shown in Fig. 5.4(a) and Fig. 5.4(b), respectively. A total of four real Z_{in} values have been obtained using the TPMN structure, with a lowest impedance of 3.8Ω and a highest impedance of 21Ω . A tuning range of 1:5.5 has been achieved while maintaining a phase deviation of less than 8 degrees for Z_{in} , over a bandwidth of 100MHz.

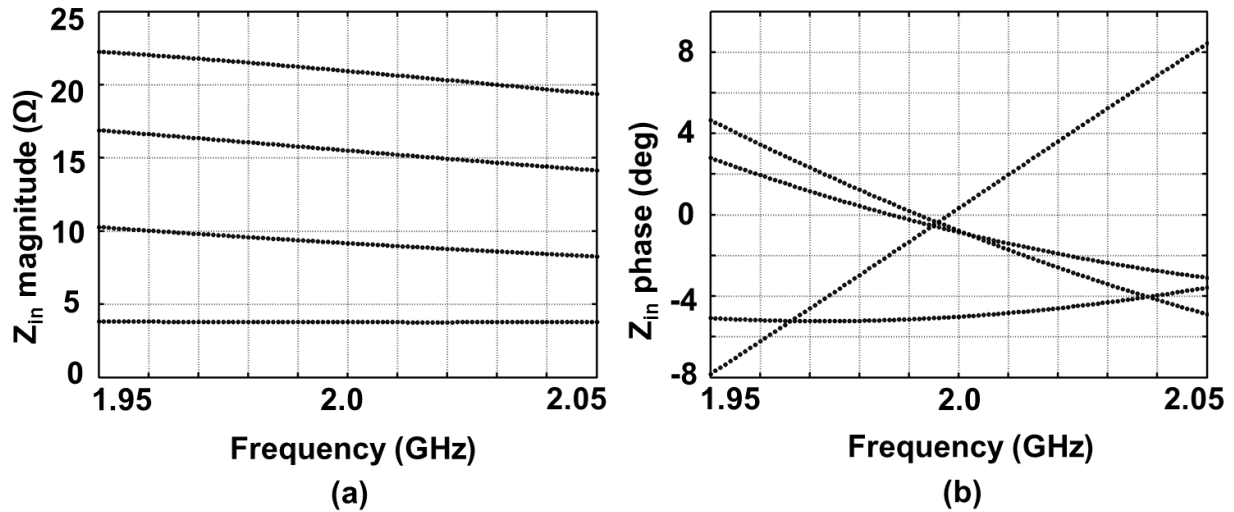

Fig. 5.4 Plot of $|Z_{in}|$ and phase (Z_{in}) Vs. frequency for different switch settings in the TPMN

The insertion loss of the TPMN structure is lower than the loss in the TLMN structure because there are no switches in the signal path. The insertion loss as a function of $\text{Re}(Z_{in})$ is reported in Table 5.2. Out of the 2.4dB total loss that is obtained, 1.9dB is the loss in the transformer and 0.5dB is the loss in the series inductor and the parallel switches. Since the majority of the loss in the network is due to the transformer, by using a higher metal stack process, better Q-factor transformers can be designed. This results in a lower loss, transformer network.

Z_{in} (Ω)	Simulation Results	
	$ S_{21} $ (Insertion Loss) (dB)	S21 phase (deg)
3.8	3.1	-95
9.2	2.4	-60
15.5	2.3	-46
21	2.3	-41

Table 5.2 Insertion Loss and phase of S_{21} across Z_{in} values in the TPMN

The 2nd column in Table 5.2 lists the phase of S_{21} across different Z_{in} values. As seen in the table, the phase variation across the entire Z_{in} range is 54 deg. This dictates the amount of signal distortion that arises if the TPMN is used for dynamic impedance tuning.

The linearity of the structure is tested by obtaining the P-1dB compression point. The plot of power gain versus input power is shown in Fig. 5.5. When the TPMN is tuned to obtain an input impedance of 3.8 Ω , 9 Ω , and 21 Ω , it achieves an input-referred 1dB compression power of 32dBm, 21dBm, and 17dBm respectively.

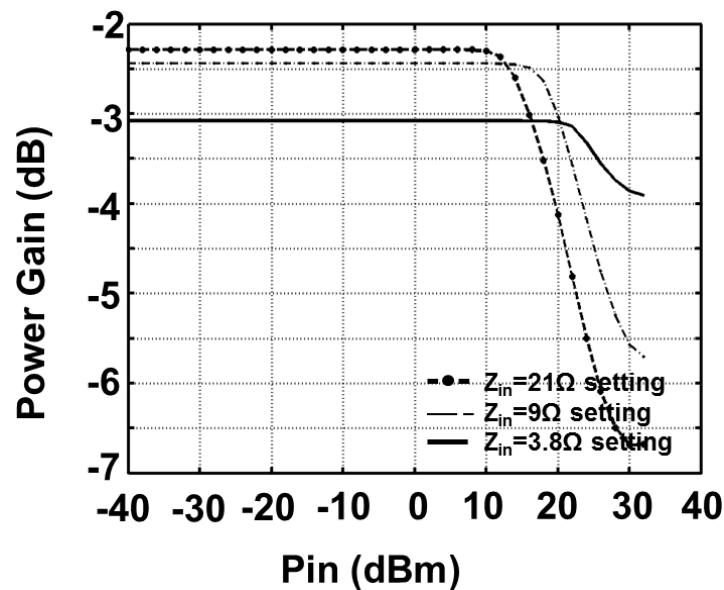

Fig. 5.5 Plot of Power gain as a function of input power in the TPMN

Similar to the TLMN, the main sources of non-linearity are the switches in the capacitor banks. However, the P-1dB compression point in TPMN structure is much higher than that obtained in the TLMN structure due to the absence of series switches in the signal path. This shows that parallel switches, where the source of the NMOS switch is connected to ground (or fixed potential), is better for linearity than having series switches.

5.3 Comparison of results of the TLMN and TPMN

The TLMN and TPMN have been designed for a bandwidth of 100MHz and center frequency of 2GHz. By controlling the state of the switch-capacitor bank, four distinct real impedances have been realized in each of these structures.

The tuning range of 1:4.8 achieved by the TLMN is comparable to the 1:5.5 range achieved in the TPMN. However, to achieve similar tuning range, the series inductance L_3 (refer to Fig. 4.2) required in the TLMN is higher than the corresponding series inductance in TPMN. As a result, the TLMN suffers 1.3dB of higher insertion loss as compared to the TPMN, as seen in Table 5.3.

	Simulation Results			
	Bandwidth (MHz)	Tuning Range	Min. Insertion Loss (dB)	Max. P-1dB (dBm)
TLMN	100	1:4.8	3.6	15
TPMN	100	1:5.5	2.3	32

Table 5.3 Comparison of the performance of TLMN and TPMN

Another drawback of the TLMN is that it requires series switches in the signal path. These switches are sized to optimize both tuning range & insertion loss and therefore, the ON resistance of the switch is higher when compared to the parallel-switches in the TPMN. In addition to increased loss, the ON resistance of the switch varies with the input signal level resulting in higher non-linearity. The P-1dB compression point of the TLMN is only 15dBm in contrast to the 32dBm compression point of the TPMN.

6. Conclusion

In this work, two tunable matching networks, designed with the explicit goal of providing large impedance-tunability and low insertion loss, at a fixed resonant frequency have been proposed. Both the matching networks, TLMN and TPMN, are fully-integrated and prototype test-chips have been realized in a 40nm bulk CMOS process.

The TLMN comprises of a transformer followed by an L-match and the TPMN comprises of a transformer followed by a Pi-match. In both the networks, the transformer provides a fixed impedance transformation, and the switch-capacitance based L/Pi-network provides a variable impedance transformation. A design methodology highlighting the loss mechanism in transformer-based matching networks is presented. Based on this methodology, circuit conditions to obtain minimum insertion loss are derived.

The TLMN and TPMN achieve an impedance transformation ratio greater than 12 and tuning ranges of 1:4.8 and 1:5.5, respectively. The minimum insertion loss of the entire network is 2.3dB with switches contributing to less than 25% of the loss. The P-1dB compression point for the TLMN and TPMN is 15dBm and 32dBm, respectively. The switch-capacitor banks in both the tuning networks have been designed to ensure all reliability constraints are satisfied, with the control voltage for the switches being 1V.

A logical extension to the work presented in this thesis would be to build a complete transmit system in which TLMN/TPMN are part of fully-integrated, closed-loop dynamic load modulation system. Ideally, in a dynamic load modulation system, the transformation ratio of the matching network will be a function of the input power to the power amplifier. Modulation

techniques such as OFDM, with large peak-to-average ratio, can potentially exploit dynamic load modulation to maximize the power efficiency of the PA in back-off.

A switch-based capacitor bank lies at the heart of the tunable matching network technique described in this work. However, a switch-based capacitor can only be tuned over a discrete set of values. In order to obtain dynamic load modulation, continuous tunability is required. Though varactors are advantageous in this scenario, the non-linearity introduced by them must be analyzed carefully. The capacitance realized by the varactor is dependent on the voltage swing appearing across it. Since the matching network is employed at the PA output, large voltage swings occur across the varactor. An interesting technique to solve this problem would be to employ the varactor in conjunction with switch-capacitor banks. The switch-capacitors can be used for selecting an appropriate range of capacitance while the varactor can be used for fine tuning of the capacitance. Thus, by restricting the capacitance obtained from the varactor to a small fraction of the total desired value, the non-linearity arising due to it can be minimized.

References

- [1] W. Wesson *et al.*, “A long-range, fully-integrated, regulator-less CMOS Power Amplifier for Wireless Sensor Communications”, *IEEE Radio Frequency Integrated Circuits Symposium Dig. of papers*, pp. 145-148, Jun 2012
- [2] K.R. Boyle *et al.*, “Analysis of Mobile Phone Antenna Impedance Variations with User Proximity” *IEEE Transactions on Antennas and Propagation*, Vol. 55, No. 2, pp. 364-372, Feb 2007
- [3] D. M. Pozar, “Microwave Engineering” 3rd ed., Wiley, 2004
- [4] A. Keerti *et al.*, “RF Characterization of SiGe HBT Power Amplifiers Under Load Mismatch” *IEEE Transactions on Microwave Theory and Techniques*, Vol. 55, No. 2, pp. 207-214, Feb 2007
- [5] B. Jiang *et al.*, “Energy Scavenging for Inductively Coupled Passive RFID Systems” *IEEE Transactions on Instrumentation and Measurement*, Vol. 56, No. 1, pp. 118-125, Feb 2007
- [6] S. Cripps, “RF Power Amplifiers for Wireless Communications”, 2nd ed. Norwood, MA: Artech House, 2002
- [7] A.M. Niknejad, “Electromagnetics for High-Speed Analog and Digital Communication Circuits”, Cambridge University Press, 2007
- [8] G. Hanington *et al.*, “High-Efficiency Power Amplifier Using Dynamic Power-Supply Voltage for CDMA Applications” *IEEE Transactions on Microwave Theory and Techniques*, Vol. 47, No. 8, pp. 1471-1476, Aug 1999
- [9] H. Wang *et al.*, “A CMOS Broadband Power Amplifier With a Transformer-Based High-Order Output Matching Network” *IEEE Journal of Solid-State Circuits*, Vol. 45, No. 12, pp. 2709-2722, Dec 2010
- [10] H. M. Nemati *et al.*, “Design of Varactor-Based Tunable Matching Networks for Dynamic Load Modulation of High Power Amplifiers” *IEEE Transactions on Microwave Theory and Techniques*, Vol. 57, No. 5, pp. 1110-1118, May 2009
- [11] F. H. Raab “High-Efficiency Linear Amplification by Dynamic Load Modulation” *IEEE MTT-S International Microwave Symposium Digest*, pp. 1717-1720, Jun 2003
- [12] Bluetooth SIG, “Bluetooth Core Specification Addendum 3 rev. 2”, Jul 2012
<https://www.bluetooth.org/en-us/specification/adopted-specifications>

- [13] Std. IEEE 802.11-2009, IEEE Standard for Information Technology-Telecommunications and information exchange between systems Local and metropolitan area networks—Specific Requirements Part 11: Wireless LAN Medium Access Control (MAC) and Physical Layer (PHY) Specifications
- [14] W.C. Edmund Neo *et al.*, “Adaptive Multi-Band Multi-mode Power Amplifier using Integrated Varactor-based Tunable Matching Networks” *IEEE Journal of Solid-State Circuits*, Vol. 41, No. 9, pp. 2166-2176, Sep 2006
- [15] P. Sjoblom *et al.*, “An Adaptive Impedance Tuning CMOS circuit for ISM 2.4-GHz Band” *IEEE Transactions on Circuits and Systems-I: Regular papers*, Vol. 52, No. 6, pp. 1115-1124, Jun 2005
- [16] J. Fu *et al.*, “Improving Power Amplifier Efficiency and Linearity using a Dynamically Controlled Tunable Matching Network” *IEEE Transactions on Microwave Theory and Techniques*, Vol. 56, No. 12, pp. 3239-3244, Dec 2008
- [17] X. Yu *et al.*, “A 2-11 GHz Reconfigurable Multi-Mode LNA in 0.13 μ m CMOS” *IEEE Radio Frequency Integrated Circuits Symposium Dig. of papers*, pp. 475-478, Jun 2012
- [18] W. Li *et al.*, “A 2.4-GHz/3.5-GHz/5-GHz Multi-Band LNA with Complementary Switched Capacitor Multi-Tap Inductor in 0.18 μ m CMOS” *International Symposium on VLSI Design, Automation and Test*, pp. 1-4, Apr 2006
- [19] X. Yu *et al.*, “Integrated Multi-Tap Transformer for Reconfigurable Multimode Matching Networks” *International Symposium on Circuits and Systems*, pp. 1395-1398, May 2011
- [20] G. Cusmai *et al.*, “A Magnetically Tuned Quadrature Oscillator” *IEEE Journal of Solid-State Circuits*, Vol. 42, No. 12, pp. 2870-2877, Dec 2007
- [21] R.G. Meyer *et al.*, “Distortion in Variable-Capacitance Diodes” *IEEE Journal of Solid-State Circuits*, Vol. 10, No. 1, pp. 47-54, Feb 1975
- [22] K. Buisman *et al.*, “Distortion Free Varactor Diode Topologies for RF Adaptivity” *IEEE MTT-S International Microwave Symposium Digest*, pp. 157-160, Jun 2005
- [23] Y. Han *et al.*, “Analysis and Design of High Efficiency Matching Networks” *IEEE Transactions on Power Electronics*, Vol. 21, No. 5, pp. 1484-1491, Sep 2006
- [24] I. Aoki *et al.*, “Distributed Active Transformer—A New Power-Combining and Impedance-Transformation Technique” *IEEE Transactions on Microwave Theory and Techniques*, Vol. 50, No. 1, pp. 316-331, Jan 2002

- [25] H. Gan “On-Chip Transformer Modeling, Characterization, and Applications in Power and Low Noise Amplifiers”, Ph.D. Dissertation, Stanford University, 2006
- [26] A.M. Niknejad *et al.*, “Analysis, Design and Optimization of Spiral Inductors and Transformers for Si RF IC’s” *IEEE Journal of Solid-State Circuits*, Vol. 33, No. 10, pp. 1470-1481, Oct 1998
- [27] K.T. Ng *et al.*, “Substrate Effects in Monolithic RF Transformers on Silicon” *IEEE Transactions on Microwave Theory and Techniques*, Vol. 50, No. 1, pp. 377-383, Jan 2002
- [28] J.R. Long “Monolithic Transformers for Silicon RF IC Design” *IEEE Journal of Solid-State Circuits*, Vol. 35, No. 9, pp. 1368-1382, Sep 2000
- [29] H. Cao *et al.*, “Linearization of Efficiency-Optimized Dynamic Load Modulation Transmitter Architectures” *IEEE Transactions on Microwave Theory and Techniques*, Vol. 58, No. 4, pp. 873-881, Apr 2010
- [30] Y. Palaskas *et al.*, “A 5-GHz 20-dBm Power Amplifier With Digitally Assisted AM-PM Correction in a 90-nm CMOS Process” *IEEE Journal of Solid-State Circuits*, Vol. 41, No. 8, pp. 1757-1763, Aug 2006
- [31] H. Samavati *et al.*, “Fractal Capacitors” *IEEE Journal of Solid-State Circuits*, Vol. 33, No. 12, pp. 2035-2041, Dec 1998