

**Growing Washington's Prison Landscapes:  
A Design & Construction Guidebook**

Graham Golbuff

A thesis  
submitted in partial fulfillment of  
the requirements for the degree of

Master of Landscape Architecture

University of Washington  
2016

Committee:  
Daniel Winterbottom  
Lynne Manzo

Program Authorized to Offer Degree:  
Landscape Architecture

**© Copyright 2016  
Graham Golbuff**

University of Washington

**Abstract**

Growing Washington's Prison Landscapes:  
A Design & Construction Guidebook

Graham Golbuff

Chair of the Supervisory Committee:  
Professor Daniel Winterbottom  
Department of Landscape Architecture  
College of Built Environments

To date, no formal framework exists for utilizing a prison landscape as a means to reduce recidivism, improve facility safety, enhance operational and ecological functionality, and foster agency and empowerment in the lives of offenders and staff. Growing Washington's Prison Landscapes represents an interdisciplinary attempt at defining, documenting and illustrating techniques to achieving those benefits through the activities of landscape design and construction. The resulting document contains standards and processes suitable for deployment at any prison facility in the state of Washington.

## **Prologue**

This thesis serves multiple purposes. It fulfills the requirements for a Master of Landscape Architecture degree at the University of Washington. Beyond that purpose though, it is primarily directed at offenders and staff within the Washington Department of Corrections as a mechanism for actively implementing landscape based programs in their facilities.

Because of this thesis' fundamental nature as a practical guide to be applied in real settings, it features a somewhat unconventional format. The core of the thesis is "Growing Washington's Prison Landscapes: A Design & Construction Guidebook." This document will subsequently be owned and administered by the Sustainability in Prisons Project, which is a partnership between the Washington Department of Corrections and The Evergreen State College.

Following the guidebook is a series of essays, "Reflections," that more closely follows the traditional structure of an MLA thesis. These essays address the critical theories and scholarship at the foundation of Growing Washington's Prison Landscapes, and add richness to the overall narrative that the practically oriented guidebook may omit.

# CONTENTS

## GUIDEBOOK

Intent	i	Preventative Pre-Planning	48
Prison Landscapes Today	1	Supervision & Crew Management	49
Historic Prison Landscapes	2	Tool & Material Management	50
Innovative Prison Landscapes	3	Sequence & Considerations	51
Why Modify & Construct Prison Landscapes?	5	Demolition	52
Establishing Project Goals	8	Rough Grading	53
Likely Spaces For Landscape Projects	9	Excavation	54
Custody Levels & Project Appropriateness	11	Drainage	55
Site Analysis	13	Concrete	56
Sustainability	16	Stone & Masonry	57
(Potential) Partners & Resources	17	Finish Grading	58
Approval Process & Project Sequencing	19	Carpentry	59
What Are Design Guidelines?	22	Metal Work	60
Footprints	23	Planting	61
Buffers	24	Celebration	63
Vertical Elements	25	Monitoring & Evaluation	64
Structural Footprints	26	Maintenance	65
Materials (General)	27		
Paths	28	Resources	
Vegetation	29	Works Cited	
Trees	30		
Furniture & Interactive Elements	31		
Process	33		
Concept & Program	34		
Survey	35		
Marking & Massing	36		
Schematics	37		
Construction Drawing	39		
<i>Visualization: Sustainability</i>	41		
<i>Visualization: Custody Unit Courtyard</i>	43		
<i>Visualization: Outdoor Recreation Area</i>	45		

# CONTENTS

## REFLECTIONS

Disclaimer	73
Context and Background to Involvement	74
History of Prison Landscapes and Affiliated Programs	76
Prison Landscape Programs: Punitive or Rehabilitative?	78
A Theoretical Framework for Growing Washington’s Prison Landscapes	80
Benefit of Prison Landscape Programming:	
◦ Reduce Recidivism	81
◦ Increase Facility Safety “Naturally”	83
◦ Enhance Operational and Ecological Function	86
◦ Foster Agency and Empowerment	89
Sequencing and Methodology	92
Reflection and Aftermath	95
Works Cited	100



# GROWING WASHINGTON'S PRISON LANDSCAPES

## A Design & Construction Guidebook



# GROWING WASHINGTON'S PRISON LANDSCAPES

## A Design & Construction Guidebook

### Prepared For:

Washington Department of Corrections  
Sustainability in Prisons Project

### Prepared By:

Graham Golbuff, Master of Landscape Architecture candidate, University of Washington-Seattle

### Project Team & Advisors:

Kelli Bush, Program Manager, Sustainability in Prisons Project

Anna Crickmer, PE, Project Manager, Capital Programs, Washington Department of Corrections

Troy Hansen, Maintenance Mechanic, Monroe Correctional Complex, Washington Department of Corrections

Sgt. Sarah Lamm, Monroe Correctional Complex, Washington Department of Corrections

Lynne Manzo, PhD, Associate Professor, Landscape Architecture, University of Washington-Seattle

Dan Pacholke, Secretary, Washington Department of Corrections

Julie Stevens, Assistant Professor, Landscape Architecture, Iowa State University

Barbara Toews, PhD, Assistant Professor, Criminal Justice, University of Washington-Tacoma

Joslyn Rose Trivett, SPP Network Manager, Sustainability in Prisons Project

Julie Vanneste, Sustainability Coordinator, Washington Department of Corrections

Daniel Winterbottom, Professor, Landscape Architecture, University of Washington-Seattle

All photos and graphics property of the Sustainability in Prisons Project unless otherwise expressly credited.

Last updated: December 2015.



UNIVERSITY of  
WASHINGTON

# CONTENTS

Intent i

## INTRODUCTION

Prison Landscapes Today 1  
Historic Prison Landscapes 2  
Innovative Prison Landscapes 3  
Why Modify & Construct Prison Landscapes? 5

## PRE-DESIGN

Establishing Project Goals 8  
Likely Spaces For Landscape Projects 9  
Custody Levels & Project Appropriateness 11  
Site Analysis 13  
Sustainability 16  
(Potential) Partners & Resources 17  
Approval Process & Project Sequencing 19

## DESIGN GUIDELINES

What Are Design Guidelines? 22  
Footprints 23  
Buffers 24  
Vertical Elements 25  
Structural Footprints 26  
Materials (General) 27  
Paths 28  
Vegetation 29  
Trees 30  
Furniture & Interactive Elements 31

## DESIGN

Process 33  
Concept & Program 34  
Survey 35  
Marking & Massing 36

## DESIGN ctd.

Schematics 37  
Construction Drawing 39  
*Visualization: Sustainability* 41  
*Visualization: Custody Unit Courtyard* 43  
*Visualization: Outdoor Recreation Area* 45

## CONSTRUCTION

Preventative Pre-Planning 48  
Supervision & Crew Management 49  
Tool & Material Management 50  
Sequence & Considerations 51  
Demolition 52  
Rough Grading 53  
Excavation 54  
Drainage 55  
Concrete 56  
Stone & Masonry 57  
Finish Grading 58  
Carpentry 59  
Metal Work 60  
Planting 61

## POST-CONSTRUCTION

Celebration 63  
Monitoring & Evaluation 64  
Maintenance 65

Resources  
Works Cited

## INTENT

You hold in your hands a collection of illustrations, standards, photos and processes to inspire and support the creation of unique landscapes within prison environments in the state of Washington. This collection, or guidebook, as it will be referred to henceforth, takes the reader through the entire sequence of prison landscape creation, from idea to implementation. It has been assembled over the course of 18 months by an interdisciplinary team of 12 individuals that hail from across corrections as well as other professional and academic disciplines, including landscape architecture, criminal justice, environmental psychology, and sustainability.

The phrase “prison landscape” immediately brings to mind the concept of a prison garden, examples of which have been found in prisons throughout history. Despite their popularity, gardens are generally not the norm in prison environments, and should continue to be thought of as unique prison landscapes. However, this guidebook aims to expand the notion of unique prison landscapes to include a variety of landscape types and features beyond the garden, including those for passive and active recreation, environmental sustainability, tangible skill building, and personal growth. In short, this guidebook outlines the steps for creating nearly any type of prison landscape or landscape element, from a flower bed, to a ball field, to an artful storm drain.

The process of creation is inherently empowering. An explicit value of the Washington Department of Corrections (WDOC) is to support the ability for offenders and staff to grow and change. As such, this guidebook serves as a resource for the offenders and staff of WDOC to conceive and implement unique prison landscapes. After all, they are the people who spend the most time in Washington’s prison environments, and are uniquely positioned to shape these often underutilized spaces.

We also intend for this guidebook to be useful to additional audiences, including designers, builders, social justice advocates, academics and administrators. While the processes, standards and details described in the document are specific to WDOC, they can feasibly be adapted for use by other correctional jurisdictions. Ultimately, it is our hope that this guidebook is helpful to anyone that wants to help change a prison landscape, no matter their identity or role.

# INTRODUCTION



*Vegetable garden and picnic seating at Rhode Island's Women's Minimum Security Facility. Photo: Garden Time; Providence, RI*

# GROWING WASHINGTON'S PRISON LANDSCAPES

## Introduction

### PRISON LANDSCAPES TODAY

Within the perimeter, the majority of modern prison landscapes are immediate in their simplicity. Almost all prison grounds are composed of some assortment of fencing, concrete pathways, large lighting fixtures, and flat stretches of turf. More complex vegetation and other landscape elements are largely absent.

The standard layout of a prison landscape does provide for high functionality, which helps influence the safety of a facility. The preservation of sight lines, the ability to move people quickly, the potential for broad application of a maintenance technique, and the ability to reduce costs are just a few of the reasons that prison landscapes have evolved as they have.

*Stafford Creek Corrections Center*



*Coyote Ridge Corrections Center*

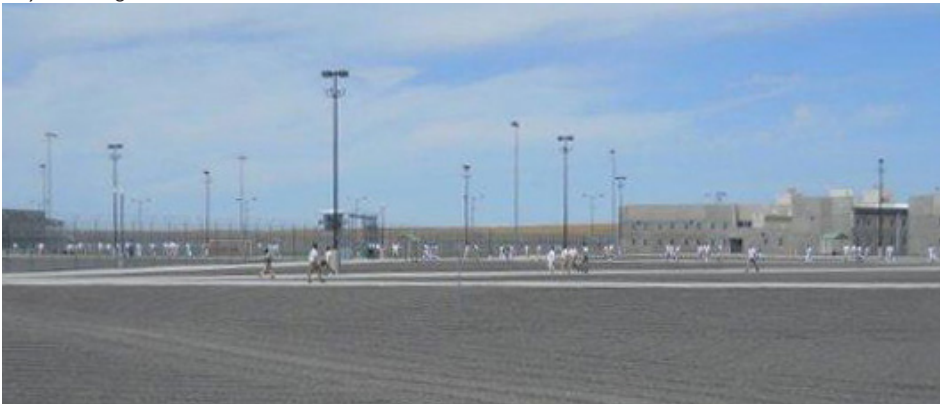

*Monroe Correctional Complex*

*Amy Lindemuth*



*Washington Corrections Center For Women*

*Benj Drummond & Sarah Joy Steele*



# Introduction

## HISTORIC PRISON LANDSCAPES

Conventional wisdom would lead one to believe that prisons are institutions that are mostly permanent and unchanging in nature. When viewed through a historical context, however, we see that prisons are in fact dynamic places whose typical layouts and spatial arrangements have changed significantly over time.

Since the inception of the US penitentiary system approximately 170 years ago, a strong self-sustaining ethic has guided programs and operations, a principal that still exists today. In the landscape, this drive for self-sufficiency resulted primarily in farms, gardens and constructed landscape features such as fences and walls. In many cases, offenders and prison staff collaborated in the design and construction phases of many of these landscape features.

### TYPICAL PRISON LAYOUT PLANS THROUGHOUT HISTORY

*Diagrams inspired by Norman Johnson*

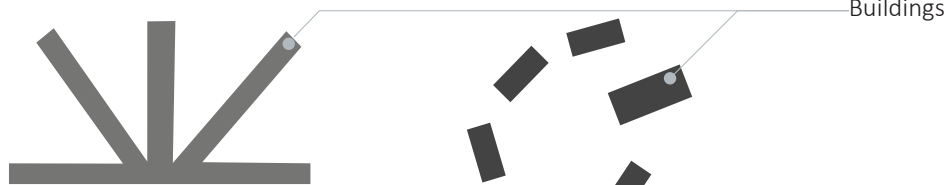

*Radial, ca. 1820-1860*

*Fragment, ca. 1840-1920*

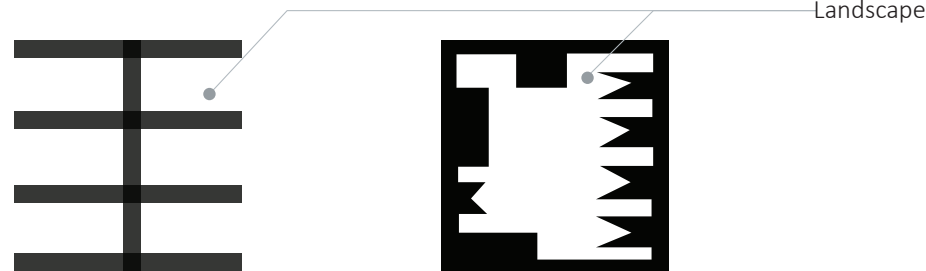

*Telephone Pole, ca. 1860-1955*

*Enclosed Campus, ca. 1950-present*

*Side Yard Gardens at Alcatraz Island, CA, 1869*

*Bill Noble*



*Prison Farm at Louisiana State Penitentiary, ca. 1900*

*Andrew Lytle*



*Rose Gardens at Sing Sing Correctional Facility, NY, ca. 1930*

*Lewis Lawes*



# GROWING WASHINGTON'S PRISON LANDSCAPES

## Introduction

# INNOVATIVE PRISON LANDSCAPES

Increasingly there are examples of prison landscapes from around the world that expand upon contemporary standards. Unique features like ponds, signage, trees, structures and seating are being incorporated into existing prison landscapes. These features preserve the functionality desired in contemporary prison landscape design, but add further value to the prison campus, be it aesthetic, ecological or recreational; or provide therapeutic benefit to its users.

Concern over site safety and facility operations, lack of landscape design and construction expertise, and inadequate funding for facility improvements are just a few reasons innovative landscapes aren't yet the norm at all prison facilities. With clear guidelines and processes outlined in these sections, the process of implementing innovative landscapes will be made easier and thus more accessible to all.

PROJECT	PARTNERS	DATES	FUNDING
West Kimberley Regional Prison	TAG Architects, Iredale Pedersen Hook Architects	2008- 2012	State revenues (\$122 million USD)
Iowa Correctional Institution for Women	Iowa State University Dept. of Landscape Arch.	2011- Present	Small grants & private donations
Rikers Island Jail	Horticultural Society of New York	1997- Present	Grants
Sustainability in Prisons Project	Washington Dept. of Corrections & The Evergreen State College	2003- Present	Grants, private donations, state revenues

Bench & wooden boardwalk at West Kimberley Regional Prison, Australia

Peter Bennetts



Outdoor classroom at Iowa Correctional Institution For Women

Heather Ligler



Gazebo & water feature at Rikers Island Jail, New York

Hilda Krus



Production gardens & organic maintenance at Cedar Creek Corrections Center, Washington



Artful garden shed at Cedar Creek Corrections Center, Washington



Signage for sustainability features at Stafford Creek Corrections Center, Washington



Biodiverse, pollinator-friendly landscape planting at Stafford Creek Corrections Center, Washington



## Introduction

### WHY MODIFY & CONSTRUCT PRISON LANDSCAPES?

The modification of any built environment requires energy, financial resources and time. Even the smallest, most routine projects can demand a significant investment from the individuals involved. Because of the challenging realities inherent in modifying a prison landscape compared to other contexts (security factors, lack of available capital/expertise, etc.), the very reasonable question of “why bother at all?” can and will arise.

There are many beneficial outcomes of modifying and constructing prison landscapes. Technical training and increased biodiversity are just two examples of possible beneficial outcomes. These benefits are often complementary and non-exclusive, meaning that a single landscape project has the potential to result in multiple beneficial outcomes.

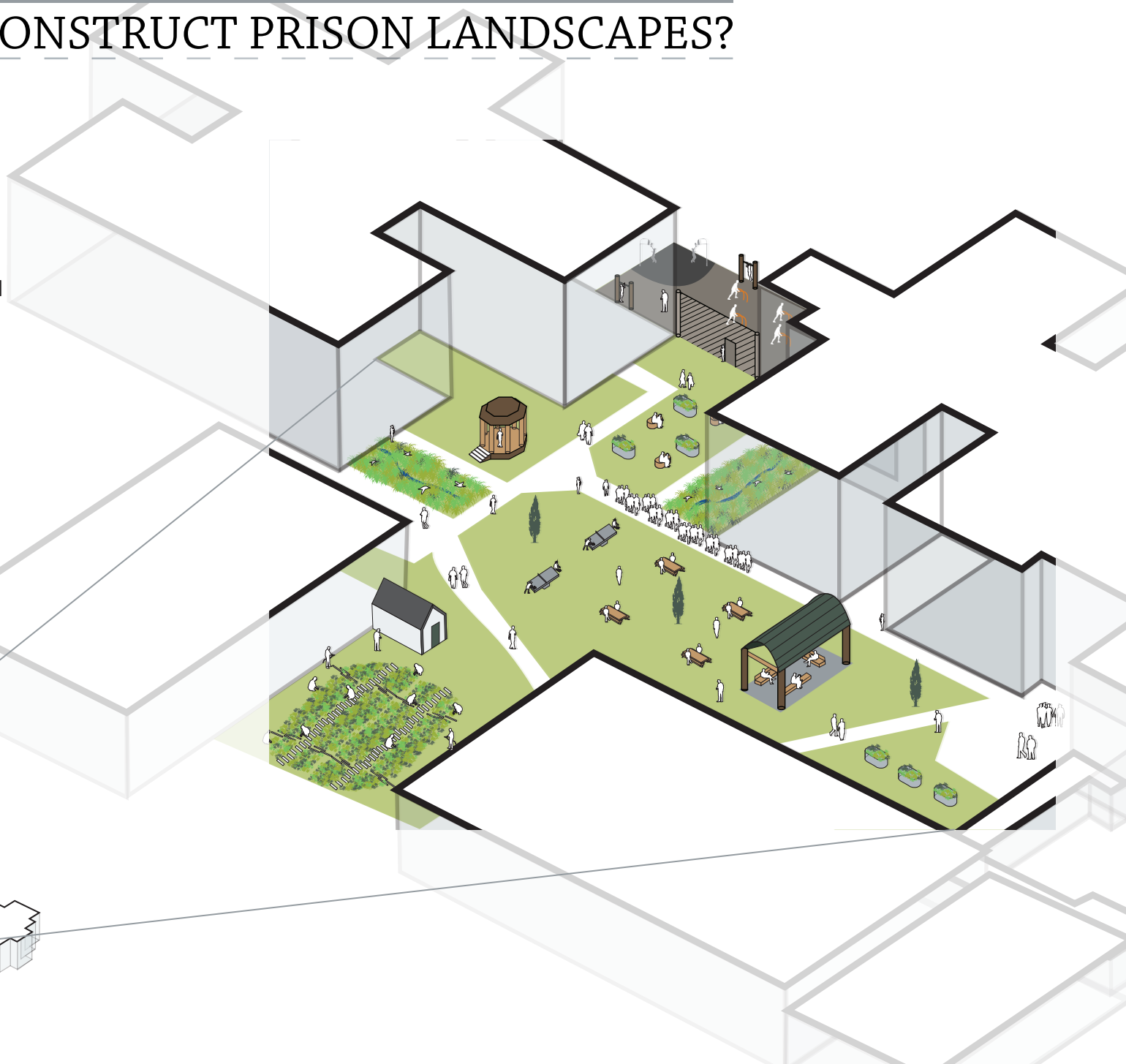
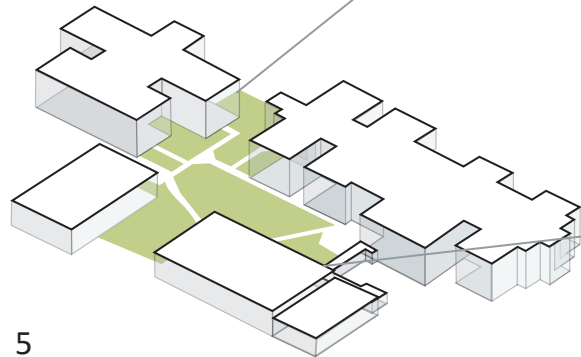

**IMPROVE FACILITY SAFETY & SENSE OF CALM**



The concept of a landscape inherently invokes natural components: vegetation, soil, stone, wood. Significant research has demonstrated that time spent in proximity to natural settings elicits calmness and mitigates physical and mental exhaustion from stress (Ulrich et al., 1991). Stress and tension are unfortunate realities of the prison experience, and can lead to compromised safety conditions (Conover, 2001). Landscape projects with natural elements can then contribute to calmer, safer conditions for all in a prison environment.

**CREATE PROGRAM OPPORTUNITY**



Amongst offenders, monotony & boredom are the most frequently identified negative aspects of the prison experience (Rhodes, 2004). Additional low cost programmatic opportunities allow prisons to provide more activities for offenders to engage in, reducing idleness and increasing facility safety.

Designed landscapes can provide space for specialized programs that require outdoor space, such as beekeeping or horticulture, or can provide unique, alternate settings for existing programs, such as outdoor classrooms and performance spaces.

**ENHANCE ECOLOGICAL FUNCTIONALITY**



Prisons are significant consumers of resources like energy and water, and provide little habitat value for critical wildlife species. A movement to “green” prisons is growing across corrections nationwide as a means to benefit both those incarcerated as well as the environment (Thigpen et al., 2011). Landscapes can be used as catalysts to achieve these goals, be it through a planting that encourages endangered pollinator species, a channel that conveys and infiltrates stormwater, or through a structure that serves as a base for solar panel infrastructure.

**EDUCATE & DEVELOP MARKETABLE SKILLS**



Vocational and other training opportunities are proven in reducing recidivism in offenders upon their release (Bouffard et al., 2000; Wilson et al., 2000). Furthermore, employers in the construction industry have demonstrated a unique willingness to hire ex offenders (Alexander, 2011). Designed landscapes require aptitude in a variety of construction techniques, from grading terrain to building a structure. Participation in crafting such spaces can leave offenders better prepared to enter the landscape and construction workforces upon release.

# PRE-DESIGN

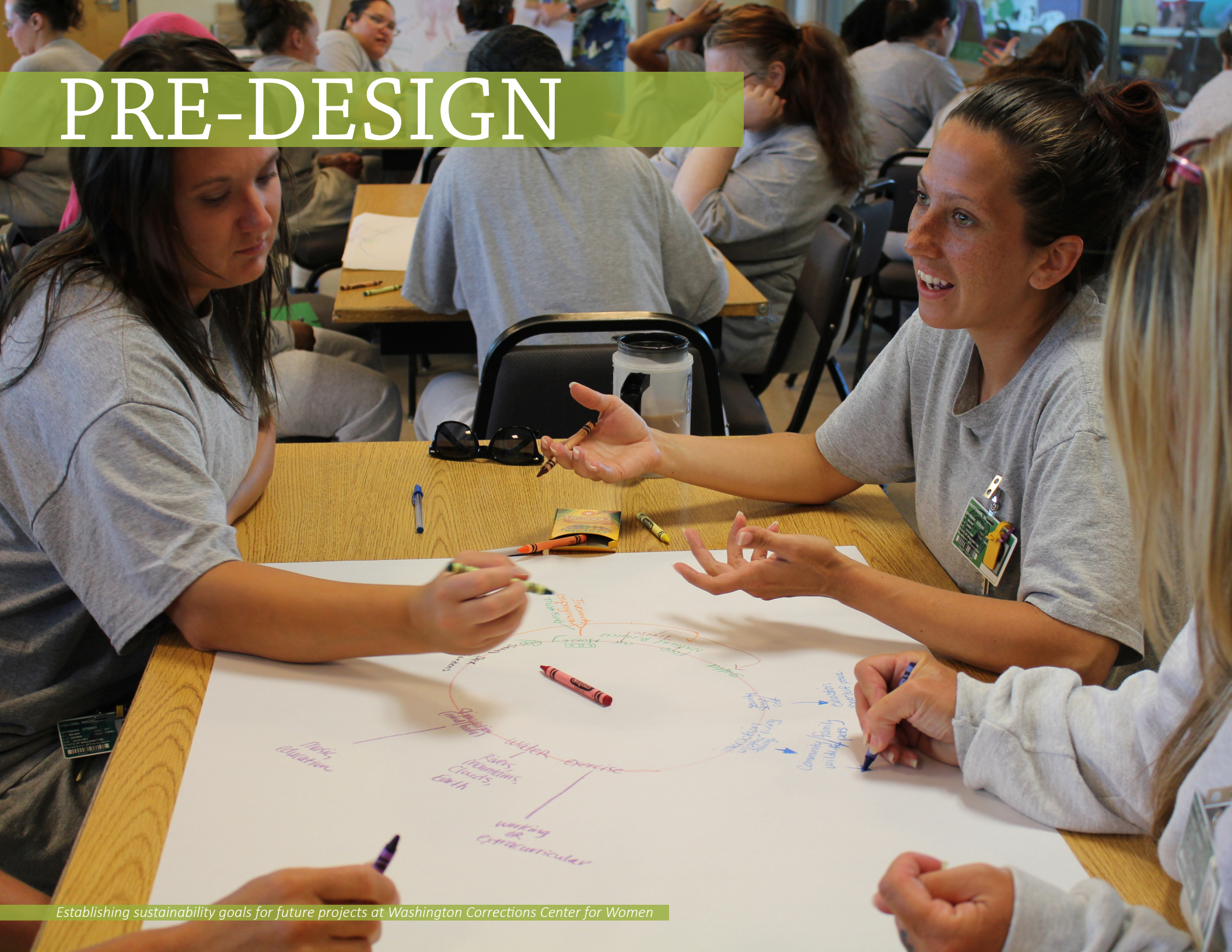

Establishing sustainability goals for future projects at Washington Corrections Center for Women

# Pre-Design

## ESTABLISHING PROJECT GOALS

The beginning of any prison landscape modification process should involve the primary parties interested in creating a designed landscape getting together and establishing common objectives. Goals can be both tangible (i.e. “the project must have vegetable gardens and seating areas”) and experiential (i.e. “project participants will learn to install drainage infrastructure”). Simply put, the project goals are what you and your team want to accomplish as an end result. When possible, project goals should strive to be mutually beneficial.

These fundamental decisions are critical guideposts during the design and construction processes, and ensure that the efforts being put forth meet their original intent. Establishing project goals also helps when communicating with other project stakeholders, including prison administration and external community groups, allowing them to understand your vision more quickly.

What follows is an example of initial project goals for a prison landscape design project at the Santa Rita Jail in Dublin, California.

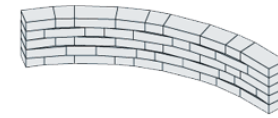

MANY SEATING OPTIONS

Quiet, individual contemplation; one-on-one counseling sessions.

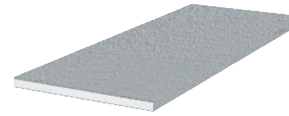

ACCESSIBILITY FOR ALL

ADA pathway materials; garden beds that can be reached from a wheelchair.



VEGETABLE GARDENS

Provide kitchens with produce; cultivate space for donating crops.

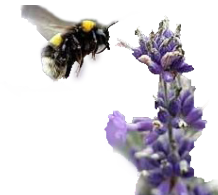

SENSORY AREAS

Appeal to touch and smell, attract pollinating insects; exhibit stark seasonal change.

## Pre-Design

### LIKELY SPACES FOR LANDSCAPE PROJECTS

It is important to understand what types of spaces exist within a prison landscape, and what types of projects those landscapes can reasonably afford. The areas described in this section are commonly understood across WDOC as being well suited for various landscape projects. Exploring how these sites can be modified to meet your project goals is a great place to start.

A variety of spaces exist within prison facilities across the state beyond those profiled here. Should your ideal site for meeting your project goals not fit one of these space types, talk with your Staff Sponsor (a WDOC staff person, often from custody, that acts as a Project Manager throughout a project's duration) about moving the project forward and see if special approval or exceptions can be arranged.

#### RECREATION YARDS

Recreation yards are the areas in prison landscapes where the most modification can occur. Because movement and activity within the site is controlled, they make great locations for a variety of site amenities, including custom built exercise features, benches, shelters, or simply some vegetation to "soften" these often "hard" sites.



James Davis



Roni Taylor



## CORRIDORS

Corridors have been specifically identified as areas in need of landscape attention by WDOC. As these are areas in which movement is controlled, only certain projects are appropriate: those that do not require stopping and interaction. Decorative plantings and sustainability features that address water quality are good project options along corridors.

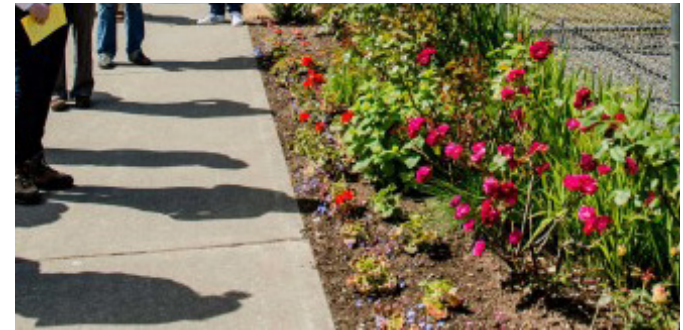

## LARGE OPEN SPACES

Large open spaces are abundant in prison landscapes and are most frequently adapted for large scale landscape projects. Productive gardens, environmental restoration, and programming areas like outdoor classrooms are all well suited for these spaces. Large open spaces are also movement controlled, but allow for more design and activity flexibility than a corridor.

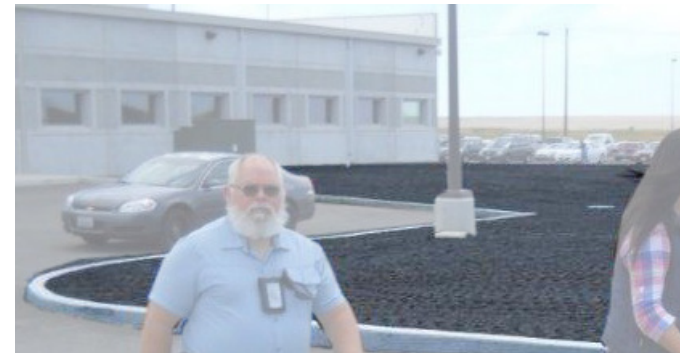

## Pre-Design

# CUSTODY LEVELS & PROJECT APPROPRIATENESS

The custody level of a prison facility is the primary factor in determining the feasibility of a particular landscape project. WDOC recognizes 4 unique custody levels: Minimum, Medium, Close and Maximum. Currently, this guidebook only addresses landscape project possibilities in the first three custody levels. Generally, as custody levels increase, so do restrictions on landscape project possibilities. This is primarily to preserve the functionality of the original prison landscape design: preserve sight lines, expedite movement, etc.; which all contribute strongly to the safety of the facility.

The matrix on the following page correlates a number of actual prison landscape projects (either currently in operation at a WDOC facility or in another innovative prison landscape) with its respective custody level. Intended to provide broad level inspiration and a means to quickly gauge the feasibility of a project idea, this matrix is not absolute. The Design Guidelines in the subsequent section will help you fine tune your project idea to its respective context.

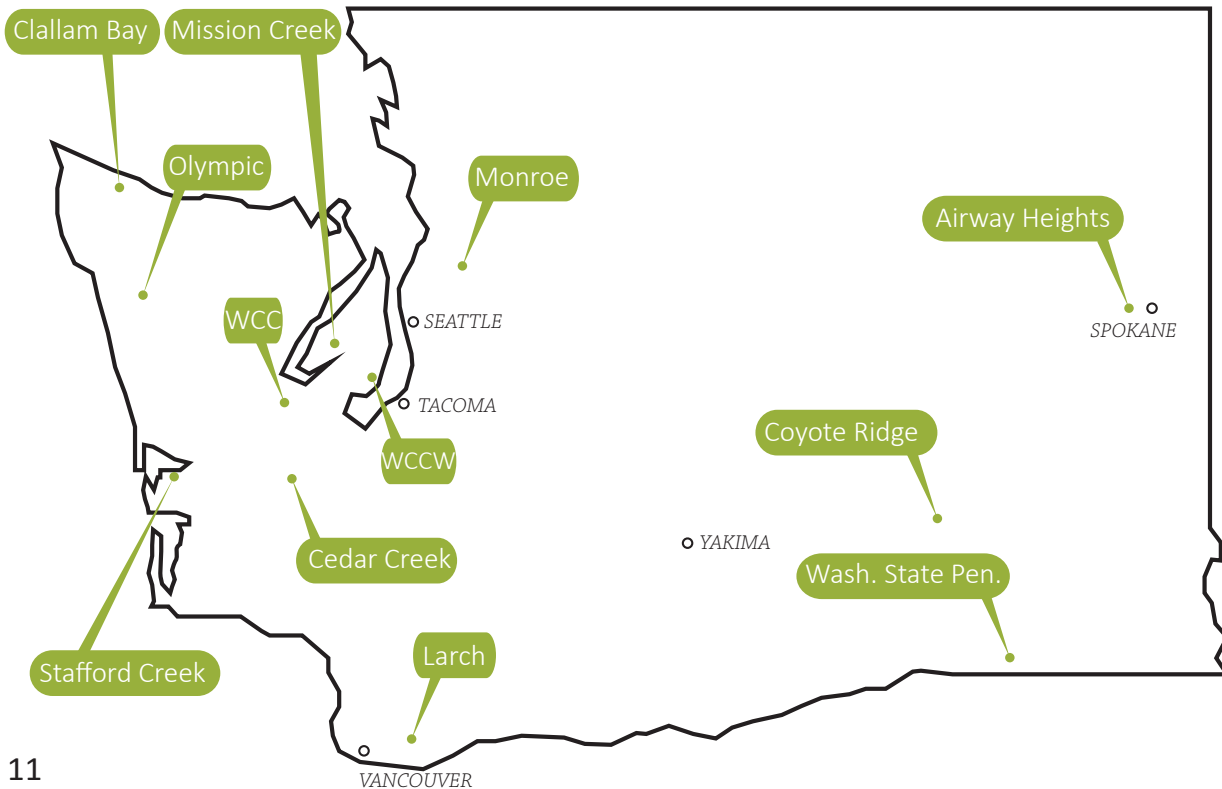

FACILITY	MIN.	MED.	CLOSE
Airway Heights	█	█	█
Cedar Creek	█	▤	▤
Clallam Bay	█	█	█
Coyote Ridge	█	█	▤
Larch	█	▤	▤
Mission Creek	█	▤	▤
Monroe	█	█	█
Olympic	█	▤	▤
Stafford Creek	█	█	█
WCC	█	█	█
WCCW	█	█	█
Wash. State Pen.	█	█	█

APPROPRIATE FOR  
**MINIMUM** CUSTODY CONTEXTS

**MEDIUM** CUSTODY

**CLOSE** CUSTODY

- Boardwalks
- Bridges
- Compost Area
- Concrete Paths
- Courtyard Garden
- Game Tables
- Gazebos
- Greenhouses
- Group Seating Area
- In Ground Plantings
- Outdoor Classroom
- Paths (Non-Concrete)
- Patios
- Performance Area
- Picnic Tables
- Quiet / Reflective Area
- Rain Gardens
- Raised Plantings
- Remembrance Area
- Sculpture
- Seat Walls
- Sensory Gardens
- Sheds
- Signage
- Stage
- Trees
- Trellises
- Vegetable Gardens
- Visitation Area
- Water Features
- Wood Fences

- Bridges
- Compost Area
- Concrete Paths
- Courtyard Garden
- Game Tables
- Gazebos
- Greenhouses
- Group Seating Area
- In Ground Plantings

- Compost Area
- Concrete Paths
- Courtyard Garden

- Gazebos
- Greenhouses

- In Ground Plantings

- Paths (Non-Concrete)

- Picnic Tables

- Picnic Tables

- Rain Gardens
- Raised Plantings
- Remembrance Area

- Sensory Gardens
- Sheds
- Signage

- Sheds

- Trees
- Trellises
- Vegetable Gardens
- Visitation Area

- Trellises
- Vegetable Gardens
- Visitation Area

- Wood Fences

- Wood Fences

## Pre-Design

### SITE ANALYSIS

Site analysis is meant to help you evaluate the relative importance and influence of different factors on a site, and to reveal qualities about the space that might not be immediately visible. The information this process reveals can be used to compare different site options, and to provide design inspiration. For example, during your analysis you may find an especially warm area of the site that would be well suited for a vegetable patch, or you may find an area where people often socialize but that lacks comfort amenities, like seating.

Record and organize your findings as you move through the process. Then, take the information that you gather and assign it different levels of importance. From there, communicate your most important findings to other project stakeholders and, as a group, consider how these important factors can work to support your project idea, or how they might need special attention during the design or construction phases.

The categories outlined here are merely a starting point. You may find the need to analyze additional criteria. Conversely, you may find that some factors you've analyzed have no influence on your project idea.

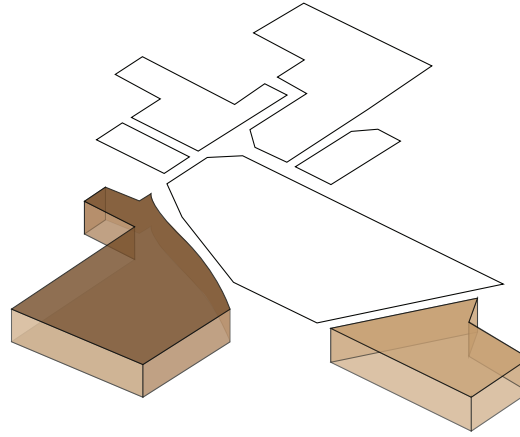

#### SOILS

Soils are the foundation of most any landscape project. With permission, begin by digging in and sampling the soil at your site. Is it light and loose or dense and compacted? Are there large rocks or is it all fine particles? Is the soil exactly the same 10 feet to the right or left of your sample area, or does it seem different? Are there many worms and bugs? Different soil types have different benefits. Plants like loose dark soils with lots of insects, while structures like to sit atop stable surfaces. Use your findings to inform your project idea.

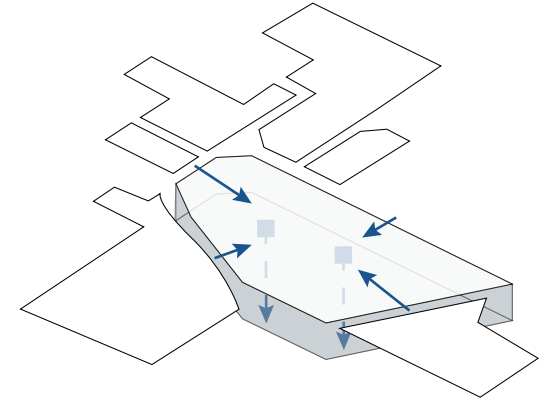

#### DRAINAGE

The way that water moves across and into a landscape is broadly referred to as drainage. Begin by noticing after a rain which areas do and do not stay saturated. Observe the direction water moves on the surface. Record any drain grates and pipes that are present. You most likely want water to move away from your project and for the surrounding area to remain dry. This analysis will reveal if the site's drainage is suitable or if some topography manipulation (berm or depression) or infrastructure (cistern, catch basin) will be required to convey and drain water adequately.

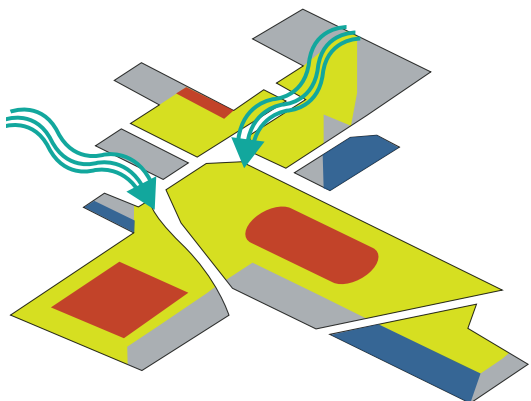

## MICRO & REGIONAL CLIMATES

Although you might be familiar with a region's climate, you are probably unfamiliar with your site's microclimates. These are areas where climate differs from its greater context; the relative warmth of urbanized areas and coolness of spaces near water bodies are two examples. Note how wind moves through the site and areas where you feel particularly warm or cool. Record sunny and shady area boundaries at regular intervals in a day. These data will have significant influence on where you place landscape elements. For example, vegetable gardens will want at least 6 hours of sun in a day and generally warm conditions, while compost areas do well in the shade.

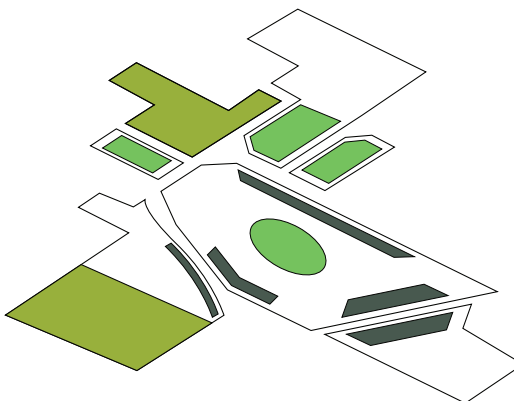

## VEGETATION

Analyzing the existing vegetation on your site adds value to your soil, drainage and climactic findings, and begins to describe the site in more experiential rather than functional terms. Note vegetation types (lawn, flowers, shrubs, etc.) and their physical boundaries. Identify the species by consulting the library or facility's horticulture program. Record if the plants seem healthy or not. Specify if the plants receive any maintenance, and if so, what is done and how often. Research the likely age of the plants as well as their and expected lifespans so you can design for their eventual replacement.

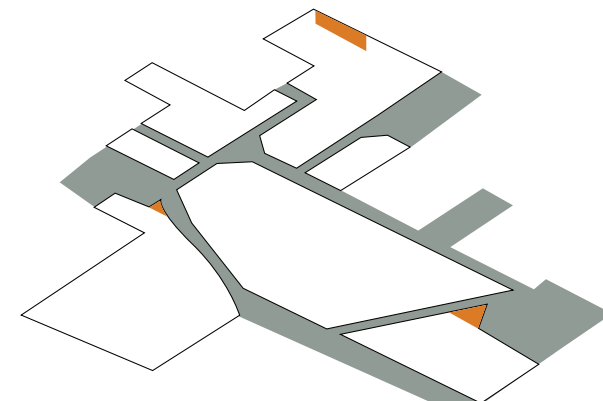

## USERS

Record who is using the site and what they're doing. Like tracking sun and shade patterns, periodic observations are the best means to get this information. Are there areas that are specific to custody officers or offenders only? Where are the spaces that those groups share? What kind of use does this space currently permit, and what might it allow? A landscape for quiet contemplation is probably not well suited for an already highly trafficked area, but signage or picnic benches might be.

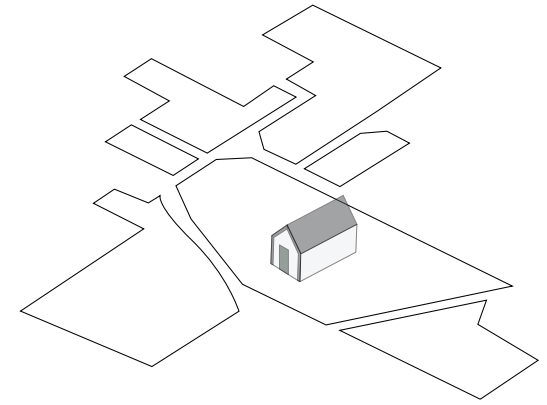
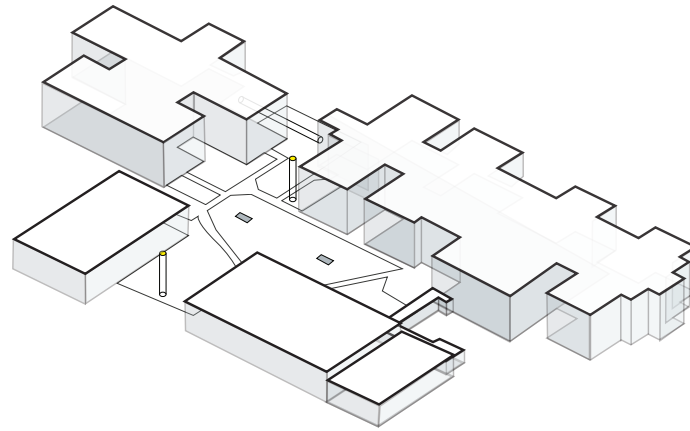
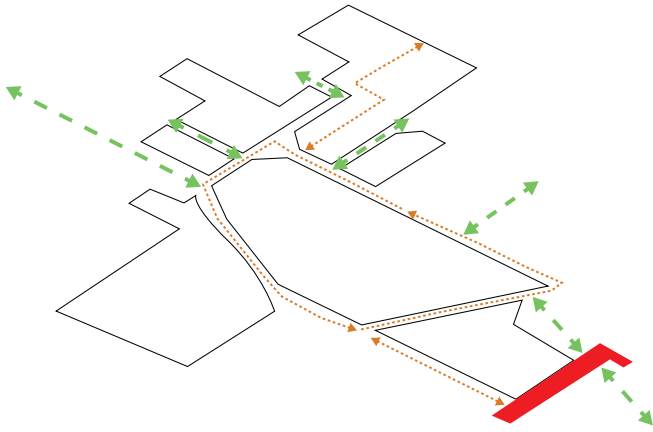

## MOVEMENT

Observe how people move through your site. Are there any short cuts taken along “desire lines?” Where does movement stop and then start up again? Are some routes used more frequently than others? How will people get from common movement corridors to your project? Think of your “movement” analysis as a subset of “users” that adds more information to those findings. Analyzing movement addresses how elements in the landscape are connected, and where opportunities to make better connections may exist.

## BUILDINGS & INFRASTRUCTURE

Take note of the “built” components in your site. Record buildings and other constructs like fences, lights, water fixtures and electrical outlets. Depending on your project idea, some of these elements will likely be advantageous and provide opportunity for irrigation, growing surfaces and other functionality. Observing and recording them now will help legitimize your final project siting decision. If possible, work with maintenance staff to learn of any below ground infrastructure that shouldn’t be disturbed by a potential landscape project.

## HISTORY

Prisons are often places with significant cultural histories. Spending some time exploring this topic can offer a trove of inspiration. Perhaps the prison site was a logged conifer forest, and you want to plant evergreens to acknowledge that past. Maybe you want to locate a garden shed where a barn used to sit. Perhaps you want a decorative element in the landscape to recall the art of indigenous peoples that inhabit and inhabited the region. Exploring history grounds you and your project to place, making the (new) site more rewarding for users.

Pre-Design  
SUSTAINABILITY



The Washington Department of Corrections operates under a self-imposed Sustainability Strategic Plan, which aims **to reduce the environmental, economic and human costs of prisons**. The design, construction & maintenance of landscapes is not always inherently sustainable. However, with some specific thought during the pre-design phase, creating a landscape that endures and gains value over time is very doable. Incorporating sustainability techniques and principals into a landscape project can not only help a prison reduce its impact on the environment and save money, but it provides opportunities to learn about new topics and receive green job training. The following is a quick primer on sustainability in the landscape. Connect with Sustainability in Prisons Project (SPP) personnel for additional technical expertise on any of these topics.



**MATERIALS**

Using **durable** and/or **recycled and re-purposed** materials ensures the project has a prolonged life cycle, which minimizes waste and reduces its embodied carbon footprint. Durable and recycled materials will also save money over time.



**WATER**

Shape your landscape to **reduce** its water use through drought tolerant plantings, hose timers and thick layers of mulch. Or, **capture** water in a cistern or rain barrel and reuse it on site.



**VEGETATION**

**Native** plants need little nutritional input, naturally resist pests and diseases, and require minimal water. **Food** plants can meet the daily needs of the prison population and the general public, if grown for donation.

## Pre-Design

### (POTENTIAL) PARTNERS & RESOURCES

Prisons are remarkably self-sufficient institutions and have many specialized resources available to help actualize landscape projects. By now you have likely identified some of your project's specific needs or technical challenges that you may face in getting it implemented. Approaching these partners for assistance and collaboration in the pre-design phase is advised to maximize the overall efficiency of implementing the project.

#### EDUCATIONAL PROGRAMS

Green Building | Art | Ecology



#### WDOC SUSTAINABILITY OPERATIONS

Recycling | Composting | Water Catchment



#### CORRECTIONAL INDUSTRIES (CI)

CAD Services (Drafting & Design)  
CNC Machining (Fabrication & Craft)



#### SHOPS

Wood | Metal  
Chair | Paint



#### CAPITAL PROGRAMS

Construction | Space Planning



#### MAINTENANCE

Carpentry | Grounds | Welding

#### HORTICULTURE & NATURE

Nurseries | Food Gardens | Restoration



WDOC & partner resources may be unable to provide support for a particular aspect of your project, and you may need to reach out for external support. A sampling of organizations providing technical assistance to communities are described below. Discuss with WDOC program staff how you can leverage the expertise of these groups, or others with similar missions, to support your project.



Architects Without Borders (AWB) is a national organization with particularly active chapters in Washington. Their mission is to collaborate with underserved communities to design and implement ecologically sensitive, culturally appropriate, and life-changing projects. AWB provides free and low-cost design services, such as conceptual design and construction drawing, for non-professionals.

An international, charitable organization devoted to constructing “simple, decent, and affordable” housing through volunteer labor, local Habitat For Humanity chapters in Washington have been involved in a number of “special” projects with scopes beyond housing. Reaching out to those programs in particular could yield assistance with site selection, construction and project management.



With 39 locations throughout the state, WSU Extension serves as the “front door” to the university’s College of Agricultural, Human and Natural Resource Sciences by building capacity of individuals and communities to find solutions for local issues. WSU Extension has expertise in food growing, low-impact development, composting and many other technical topics.

For project ideas with a strong environmental sustainability component, the Washington Department of Ecology provides a variety of technical assistance documents intended for the general public. WDOE’s Rain Garden Handbook, Stormwater Management Manuals and Low Impact Development Technical Guidance Manuals are just three examples. Search “Technical Resources” at [www.ecy.wa.gov](http://www.ecy.wa.gov) for access.



A professional society exists for nearly every specialized profession, many with local chapters and service based components of their programming. ASLA and ASCE are just two that might be of use for survey or drafting needs, but seeking similar groups from additional disciplines can help accomplish almost any specialized task.



# GROWING WASHINGTON'S PRISON LANDSCAPES | PRE-DESIGN

depending on your project, all steps may not be necessary, and additional steps may be required.

## DESIGNER

Offender and/or any WDOC Staff Member



## PROJECT MANAGER (PM)

Custody Staff and/or Staff Sponsor



## CONSTRUCTION MANAGER (CM)

Maintenance Staff



## OWNER REPRESENTATIVE

Custody Unit Supervisor (CUS), and/or Capital Programs (HQ)



## EXTERNAL PARTNER

Representative(s) from a supporting agency



## PRE-DESIGN

Establish Project Goals

Scout Site(s)

Site Analysis

Solicit Partners

Support Pre-Design\*

Partner Coordination

\* an underlined task indicates a requirement before proceeding to the next project phase.

\*\* KITE is jargon within WDOC for a standardized internal memo or form that offenders can use to make suggestions (programmatic and otherwise) to custody staff and custody unit supervisors.

Solicit Volunteer Opportunities

Complete Volunteer Protocols

Support Pre-Design

## DESIGN

Secure Staff Sponsor (KITE\*\*)

Conceptual Design & Program

Initial Maintenance Study

Submit Needed Work Requests

Partner Coordination

Obtain CUS Approval

Technical Design Support

Request Additional Drawings

Concept Design Review

Solicit HQ Assistance

Technical Design Support

# APPROVAL PROCESS & PROJECT SEQUENCING

## DEVELOPMENT



## CONSTRUCTION



## POST-CONSTRUCTION

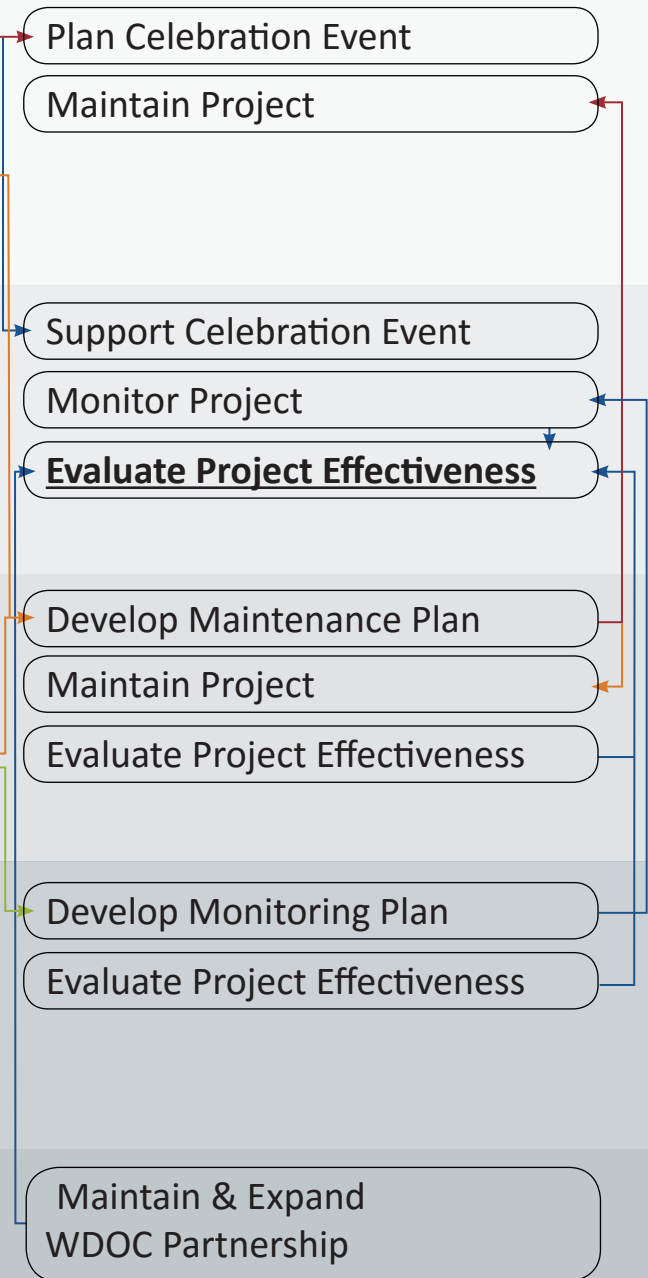

# DESIGN GUIDELINES

10,000 SQ FT  
MAX FOOTPRINT

20' FENCE  
BUFFER

VEGETATION  
36" TALL

STRUCTURE  
MAX FOOTPRINT  
20' x 20'

*Illustration of landscape features at HM Prison Whatton, Nottinghamshire, UK. Drawing: Katherine Cannella*

### WHAT ARE DESIGN GUIDELINES?

Design guidelines are modification standards that have been approved by an administrative body. In the case of guidelines for prison landscape projects, they exist to ensure that any modifications are safe, appealing, functional and feasible. Design guidelines are common in most every public design and construction effort. In our case, guidelines for prison landscape projects have been developed and approved by WDOC custody, maintenance, program and administrative staff, using information from successful innovative prison landscapes in WDOC facilities as well as from other prisons around the country.

### HOW TO USE THESE GUIDELINES

These guidelines are most easily used in the early stages of the design process, which is covered in detail in the next section. It is helpful to get to know the guidelines now so that your design process can happen more efficiently by operating within the approved standards. Think of these guidelines as resources or opportunities rather than restrictions. Not only do guidelines ensure that ideas are possible and can be actualized (as opposed to remaining only ideas), but guidelines can often inspire creativity and innovation in ways that can surprise a project team.

*Certified Wildlife Habitat Garden at Washington Correctional Institution For Women*

*Benj Drummond & Sarah Joy Steele*



# FOOTPRINTS

The overall footprint of a project helps dictate its scale within the greater prison landscape. Footprints are calculated in square feet (sq ft). Determine the footprint of your project by measuring key dimensions and calculating the area. Area calculations depend on the shape of your proposed intervention. The formulas for many common shapes are described below.

As long as your project footprint does not exceed the maximums described in the diagram on the right, your project meets the criteria for this guideline.

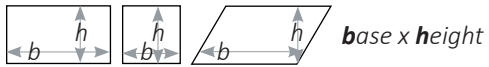

$1/2 \times \text{base} \times \text{height}$

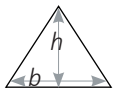

$3.14 \times \text{radius}$



$1/2 \times (a + b) \times \text{height}$

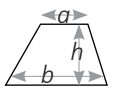

$3.14 \times a \times b$

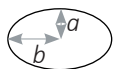

$1/2 \times \text{radius}^2 \times \text{Angle}$

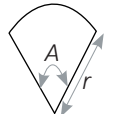

## **MINIMUM** **12,000 SQ FT MAXIMUM**

$100' \times 115' = 11,500 \text{ sq ft}$

**MEETS DESIGN GUIDELINES**

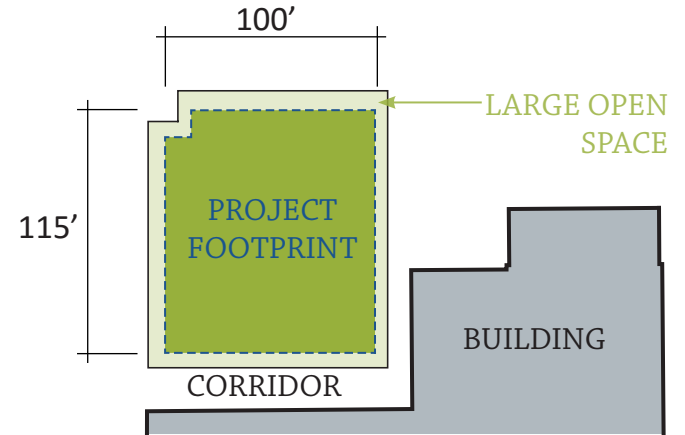

## **MEDIUM** **10,000 SQ FT MAXIMUM**

$92.5' \times 107' = 9897.5 \text{ sq ft}$

**MEETS DESIGN GUIDELINES**

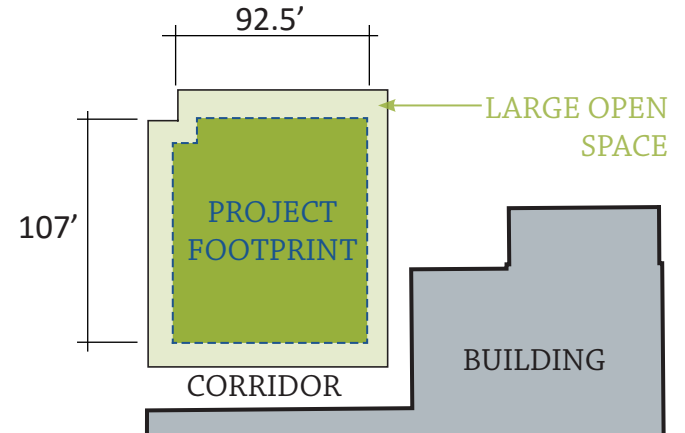

## **CLOSE** **6,500 SQ FT MAXIMUM**

$73' \times 84' = 6,132 \text{ sq ft}$

**MEETS DESIGN GUIDELINES**

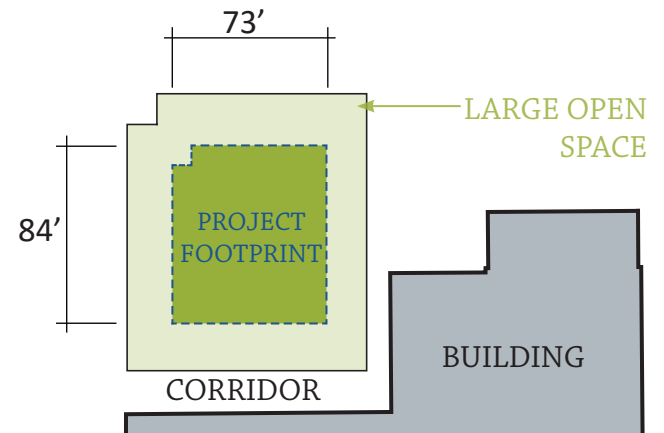

# BUFFERS

Buffers are utilized in prison landscape projects to ensure clear definitions of space, to concentrate activity, and to increase safety by preserving sight lines. Buffer spaces must be kept free of modification with the exception of modest access means (e.g. a path).

In the case of perimeter fences (“double fences”), a minimum 20’ buffer must be maintained. For interior fencing that divides and defines different spaces, it may be possible to modify right up to the fence edge. Begin by using a Minimum custody level buffer standard, and discuss with your Staff Sponsor the possibility of extending to an interior fence edge if necessary. See the annotated photos below for additional context.



**MINIMUM**  
**5' MINIMUM**  
From Building & Path Edges

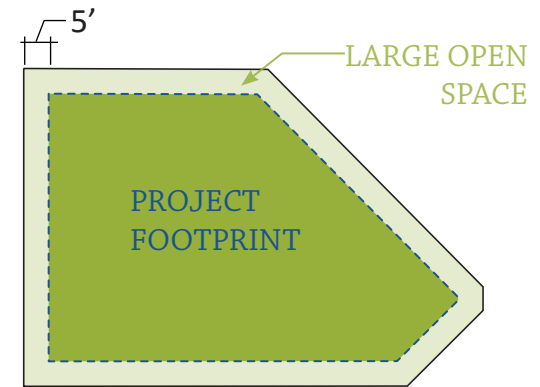

**MEDIUM**  
**10' MINIMUM**  
From Building & Path Edges

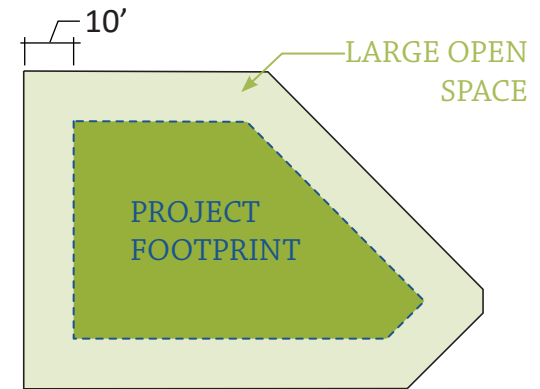

**CLOSE**  
**20' MINIMUM**  
From Building & Path Edges

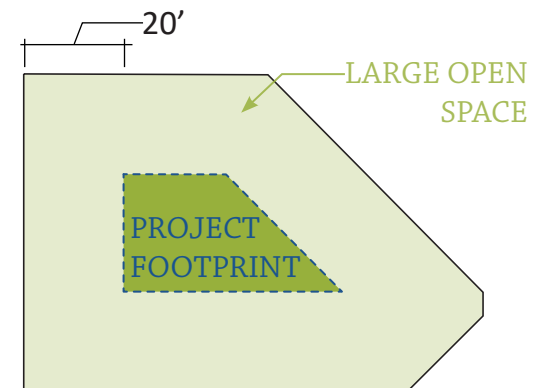

## VERTICAL ELEMENTS

Sight lines can be compromised with each insertion into the prison landscape. These guidelines illustrate best practices for scaling your project into space above the ground while maintaining safety and functionality. Guidelines for vertical elements are standard across custody levels.

APPLICABLE TO  
**MINIMUM,  
MEDIUM  
& CLOSE**  
CUSTODY LEVELS

### **CLOSED SIDED STRUCTURES** 10' MAXIMUM HEIGHT

If your project has walls or other vertical elements made from any opaque material (wood, metal, etc.), you must meet this guideline. Such structures could include sheds, greenhouses, and programmatic spaces such as bee box housing.

### **OPEN AIR STRUCTURES** 12' MAXIMUM HEIGHT

With translucent materials (glass, clear plastic), or no siding, you can extend a bit more into vertical space than you would with opaque materials. Gazebos, picnic coverings and trellises are some of the common forms that might meet this criteria and appear in a prison landscape project.

### **VEGETATION** 36" MAXIMUM HEIGHT

Plant forms at this size or smaller are perfectly suitable in any custody context. Note that if planting in a raised bed, the structure's height counts towards the 36" maximum. ADA guidelines recommend 18-24" high raised planting beds.

### **GROUND PLANE** 12" MAXIMUM VARIATION

You may consider forming mounds or depressions to create microclimates for plantings, to direct the movement of water, or simply for visual intrigue.

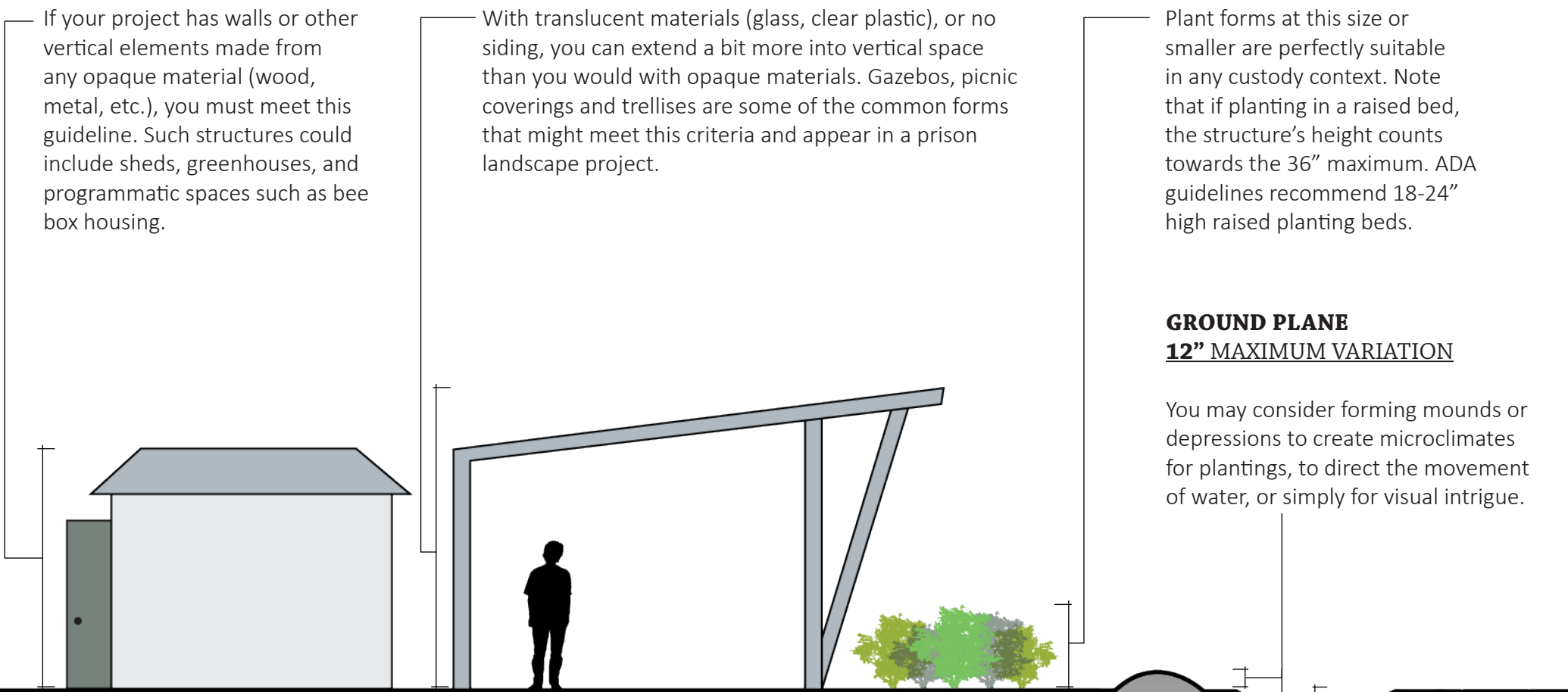

# STRUCTURAL FOOTPRINTS

Now that you know the maximum vertical heights of any structural element you place in the landscape, it will be helpful to know the maximum footprints that structures can occupy.

You'll see that these footprints are much smaller than the total footprints described earlier. This is to ensure that structures do not dominate the landscape and that a character of openness in the greater prison landscape is preserved.

## APPLICABLE TO MINIMUM, MEDIUM & CLOSE CUSTODY LEVELS



### **CLOSED SIDED STRUCTURES** 150 SQ FT MAXIMUM

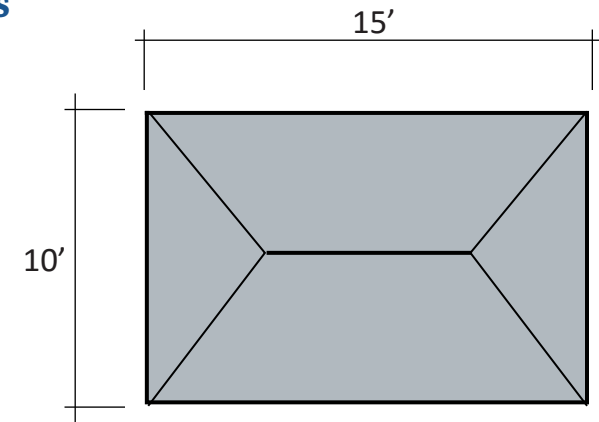

### **OPEN SIDED STRUCTURES** 400 SQ FT MAXIMUM

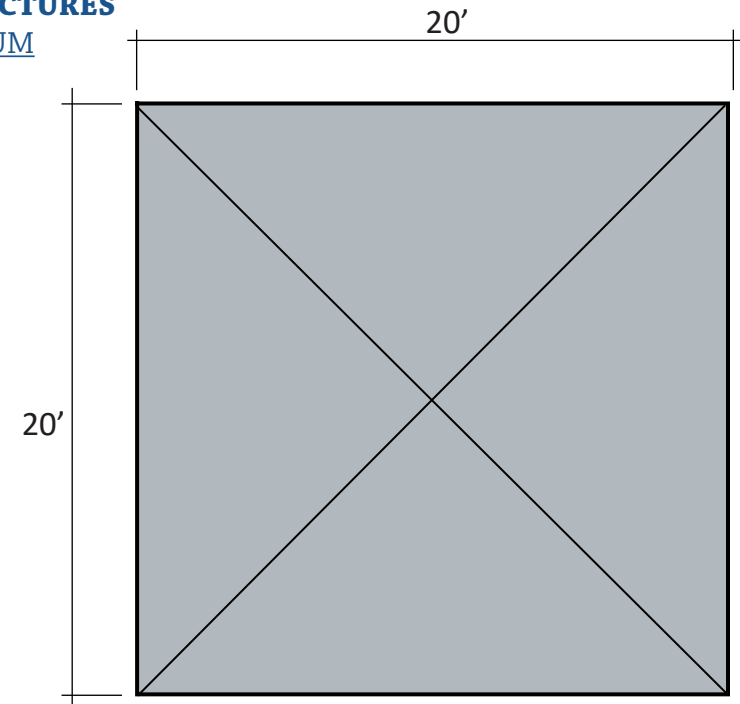

*Note: This diagram depicts roof plans to illustrate square footage, but the roofs of your structures do not have to conform to the shapes or pitch orientations illustrated here.*

# MATERIALS (GENERAL)

You've figured out how big your project can be and determined where it's going to go. Now you can give some thought to the materials that you want to use in it.

In selecting materials it is important to strive for durability and weather resiliency. As discussed in the Pre-Design section, recycled or salvaged materials help enhance the overall sustainability of your project.

As you select materials, give some thought to the permanence of your project. We know that prison landscapes do change over time, so the more your project's materials can be disassembled and repurposed if things need to change, the better.

## MINIMUM

- Wood
- Concrete
- Vegetation
- Plastic
- Stone
- Masonry
- Metal



## MEDIUM

- Wood
- Concrete
- Vegetation
- Plastic
- Stone
- Masonry
- Metal



*Metal can often be taken apart, which can present safety concerns.*

## CLOSE

- Wood
- Concrete
- Vegetation
- Plastic
- Stone
- Masonry
- Metal

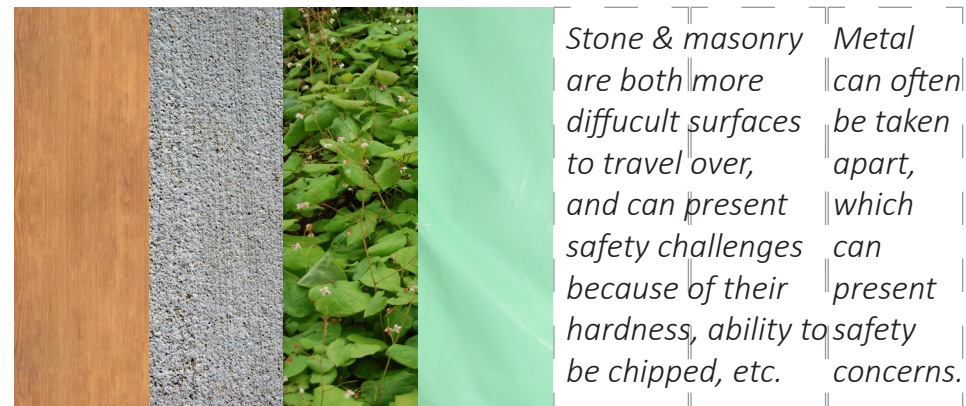

*Stone & masonry are both more difficult surfaces to travel over, and can present safety challenges because of their hardness, ability to be chipped, etc. Metal can often be taken apart, which can present safety concerns.*

# PATHS

Paths are some of the best opportunities to balance aesthetic intrigue with functionality in a landscape. A well designed and constructed path encourages exploration of a landscape, allows people and other materials to move efficiently in and out of the space, and can be a canvas for patterns and ornamentation that provide visual interest.

Standards for path widths and materials in prison landscape projects vary slightly depending on custody contexts. As you design, consider how different materials and their arrangement can provide different experiences (think the way walking on gravel or brick feels compared to walking on concrete)

There is an infinite amount of artistic touches that can be applied to path materials. Scoring interesting patterns into concrete or creating mosaics from different stone types are just two examples. A sampling can be seen in the matrix below.

As you experiment with paths, remember that ornamentation or interesting design does not have to compromise functionality and accessibility.



## **MINIMUM**

**5' MINIMUM**

Path Width

### **MATERIALS**

CONCRETE  
STONE | GRAVEL  
MASONRY

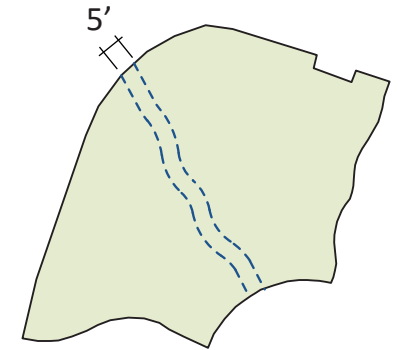

## **MEDIUM**

**8' MINIMUM**

Path Width

### **MATERIALS**

CONCRETE  
STONE | GRAVEL

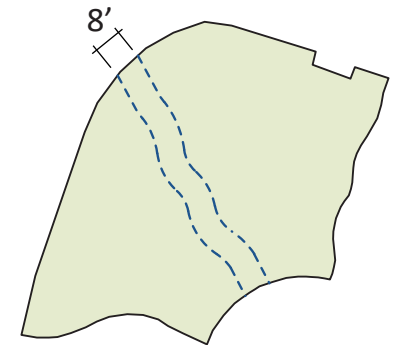

## **CLOSE**

**10' MINIMUM**

Path Width

### **MATERIALS**

CONCRETE

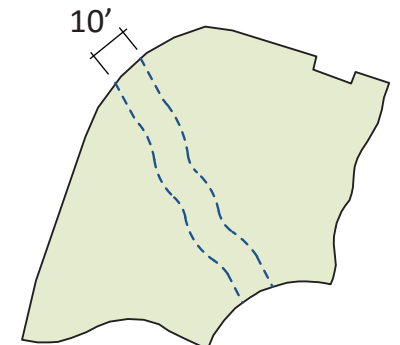
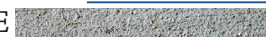

# VEGETATION

Vegetation is one of the most common elements in any landscape, and is perhaps the most frequently used material in past prison landscape projects. Plants help “soften” spaces and make areas more inviting and pleasant.

Selecting plant materials can be a challenging process, and the combination of possibilities is infinite. Best practice guidelines are illustrated on the right. For additional assistance, consult with your facility’s horticulture program, grounds staff, and library.

APPLICABLE TO  
**MINIMUM,**  
**MEDIUM**  
**& CLOSE**  
 CUSTODY LEVELS

## ACCEPTABLE



### PLANT & CONTAINER HEIGHTS



*Cornus sericea*  
Red Osier Dogwood



*Hamamelis sp.*  
Witch Hazel

### PRESERVE TRANSPARENCY

*twiggy growth, minimal leaves*



*Nandina domestica*  
Heavenly Bamboo



*Nandina domestica*  
Heavenly Bamboo

### MULTI-SEASON INTEREST

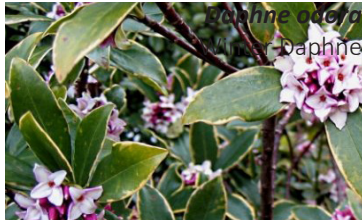

*Genkya odorata*  
Daphne



*Festuca idahoensis*  
Idaho Fescue

### SENSORY VALUE

*smell, touch, hear, taste (vegetables & herbs)*



*Symphoricarpos albus*  
Snowberry



*Ribes sanguineum*  
Red Flowering Currant

### NATIVE & SUSTAINABLE

*drought tolerant, habitat enhancing*

## REQUIRES PERMISSION



### SUGARY BERRIES & FRUITS

*pruno-making potential*



### THORNED OR BARBED FOLIAGE

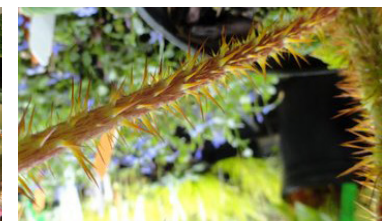

### PEPPERS

*safety compromising potential*



### SMALL PLANTS IN LARGE CONTAINERS

*contraband hiding potential*



# TREES

Trees are some of the most difficult materials to work with in the prison landscape because of their size, but when thoughtfully considered, they can add incredible value to a space.

Design standards for trees in prison landscapes primarily relate to their totals (or concentration) within a defined space, and are based on analyses of existing WDOC landscapes and other unique prison landscapes. The diagrams on the right illustrate custody specific information for siting trees inside the security perimeter. Standards for trees beyond the security perimeter are not set, but are generally more flexible than the standards for within.

Equally important to tree concentration are their growth forms and habits. Species should be selected for transparency and upright character rather than umbrella-like growth forms. Birch, arborvitae, aspen and Japanese maples are just a few options that generally fit these criteria and are acceptable trees. As with smaller plants, consult with your facility's horticulture program, grounds staff or library for additional information and support.

In all cases **trees and bushes will require special permission** from the project's Staff Sponsor. Be sure to secure this early in your process.



**ACCEPTABLE**



**AVOID**

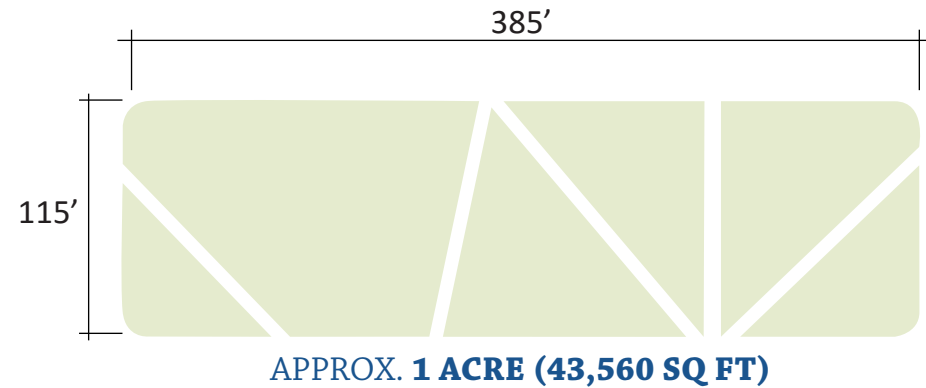

**MINIMUM**

3 TREES MAXIMUM Per Acre

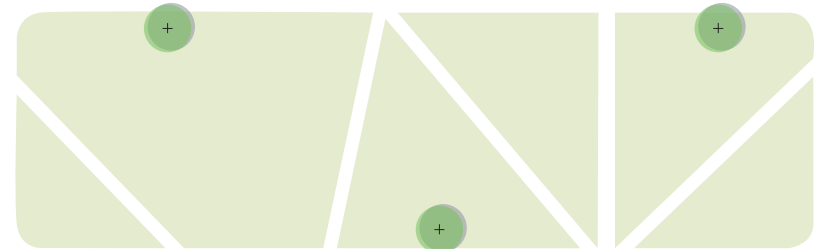

**MEDIUM**

2 TREES MAXIMUM Per Acre



**CLOSE**

1 TREE MAXIMUM Per Acre



# FURNITURE & INTERACTIVE ELEMENTS

Structural items that have a specialized purpose, such as benches, game tables and exercise equipment, can add both aesthetic intrigue and function to a landscape project. Bright colors and bold forms spark curiosity and encourage users to engage with the space. The key design guideline for these elements, aside from their not exceeding the structural footprint standards described earlier in this section, is their proper placement within a specific prison landscape type.

Existing recreation areas are very fit to accommodate furnishings and interactive elements. Large open areas are a bit more questionable for these items. In their current state(s), they are controlled movement areas. Provided the rest of the space is modified to accommodate a new type of program or activity, such as a garden space or outdoor visitation area, these elements can be accommodated. Furniture and interactive objects are not well suited for corridors or other specifically designated controlled movement areas.

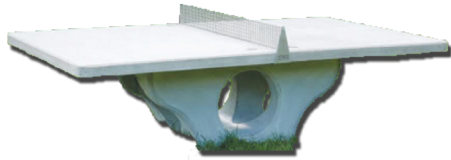
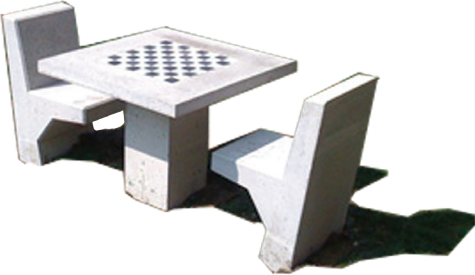
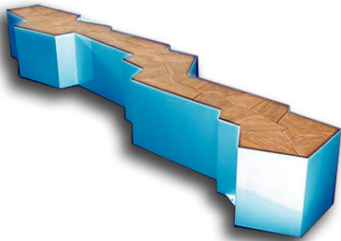
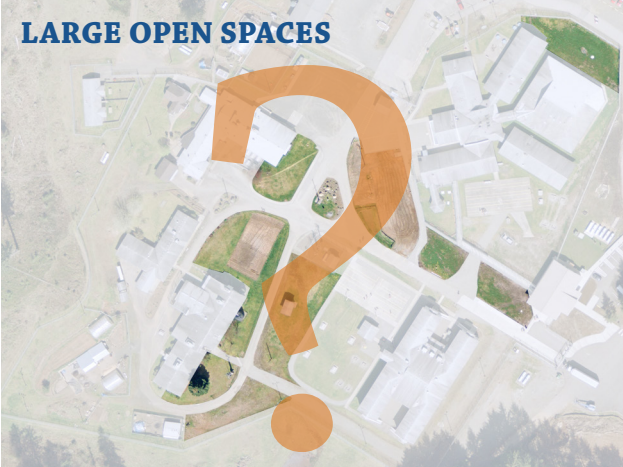
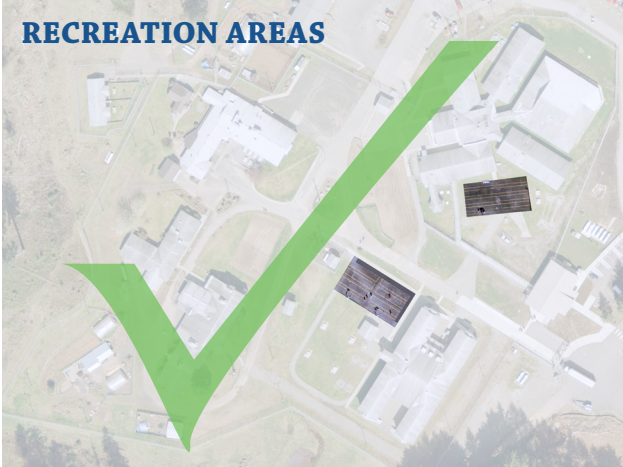

# DESIGN



Offenders at Santa Rita Jail (CA) present their design for the Cherryland/Ashland re-entry campus. Photo: Deanna Van Buren ([designingjustice.com](http://designingjustice.com))

Design  
PROCESS

Taking an idea for a landscape project into construction is a process of replication and overlap. This section will give a broad sense of all the steps that could possibly be needed to take a prison landscape project idea to implementation, along with documentation required and resources to help as you proceed. The diagram below holistically illustrates the sequence of the steps in the prison landscape design process, and each step is explained in greater detail later in this section.

While the idealized design process is composed of distinct phases in a linear sequence, in the real world the design process doesn't always work out exactly as is illustrated below. It is not uncommon for phases to require revision, or be deemed unnecessary and skipped entirely. Those determinations are to be made by the project's Staff Sponsor, the Project Manager, the Construction Manager and/or the Owner's Representative, rather than by the designer. Throughout the process, those individuals will provide feedback on what design steps are still needed before the project can move into construction.

Similarly, sometimes the phases of the design process all take an equal amount of time, and sometimes some phases go much more quickly than others. Allow yourself and the design the flexibility it needs to move forward.

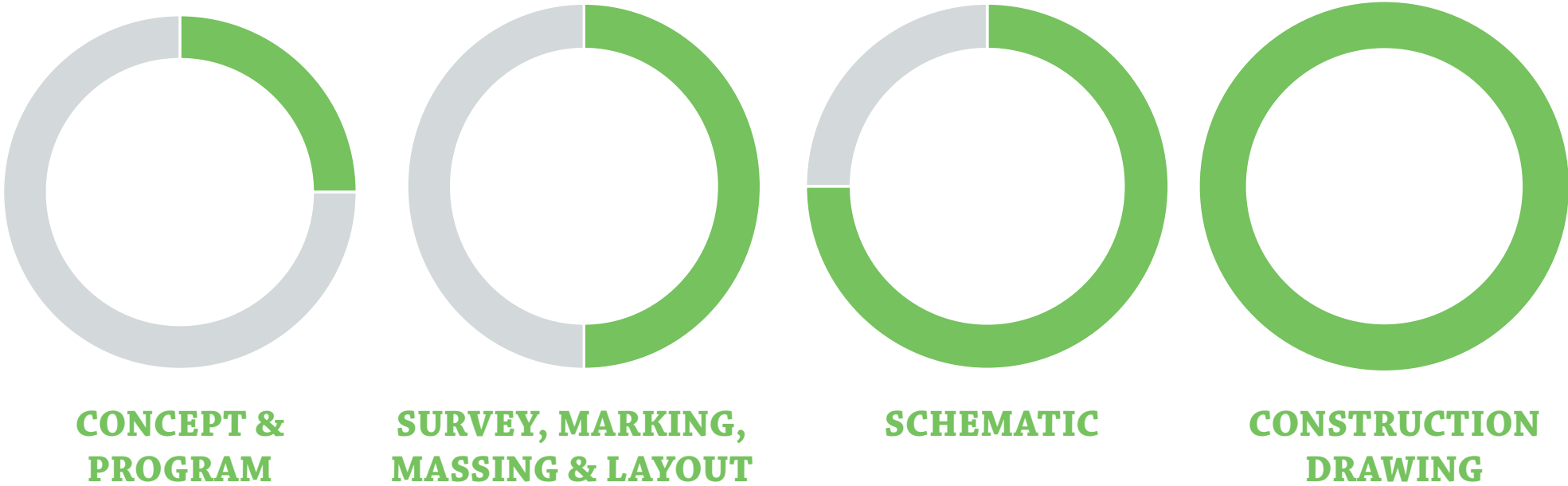

# Design

## CONCEPT & PROGRAM



Concept design is an initial attempt at giving shape to your project goals while responding to prison landscape design guidelines. These drawings illustrate how landscape elements relate to one another in space and in function. Drawings at this stage are composed primarily in “plan” view, like a map.

Concept and program drawings do not need to be realistic or spatially accurate. The more they meet those criteria, the more you may be able to bypass subsequent design steps, but in many cases minimal markings, notes on the drawings, and bold abstracted forms work best. These markings show the core of your idea and help the project’s reviewers avoid getting immediately lost in other details that could arise.

At bare minimum, submission of a concept drawing is required for a landscape project at a WDOC facility to move forward. Use text to describe what your markings represent and indicate distances and dimensions when possible.

Three dimensional models from everyday materials are also effective items to work with during concept and program design. In some cases they may be able to be substituted for a concept plan drawing.

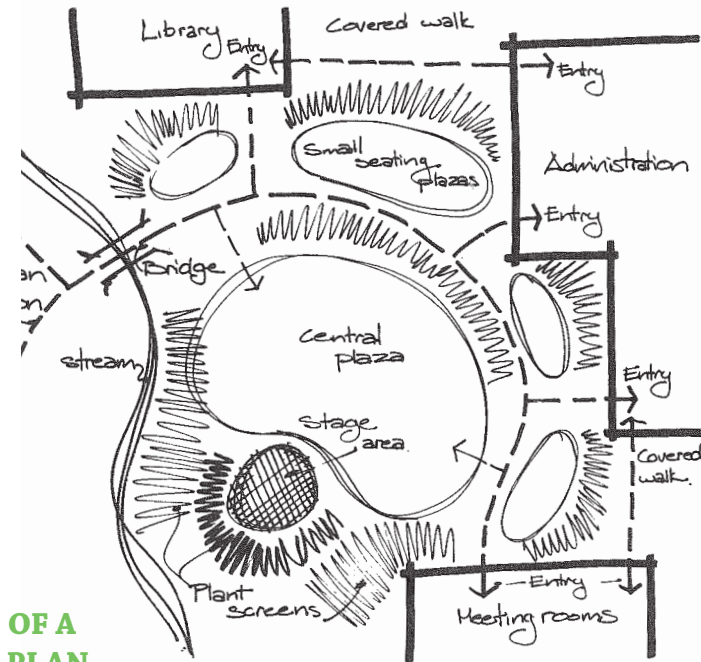

**EXAMPLE OF A CONCEPT PLAN**

*Designer: Grant Reid*

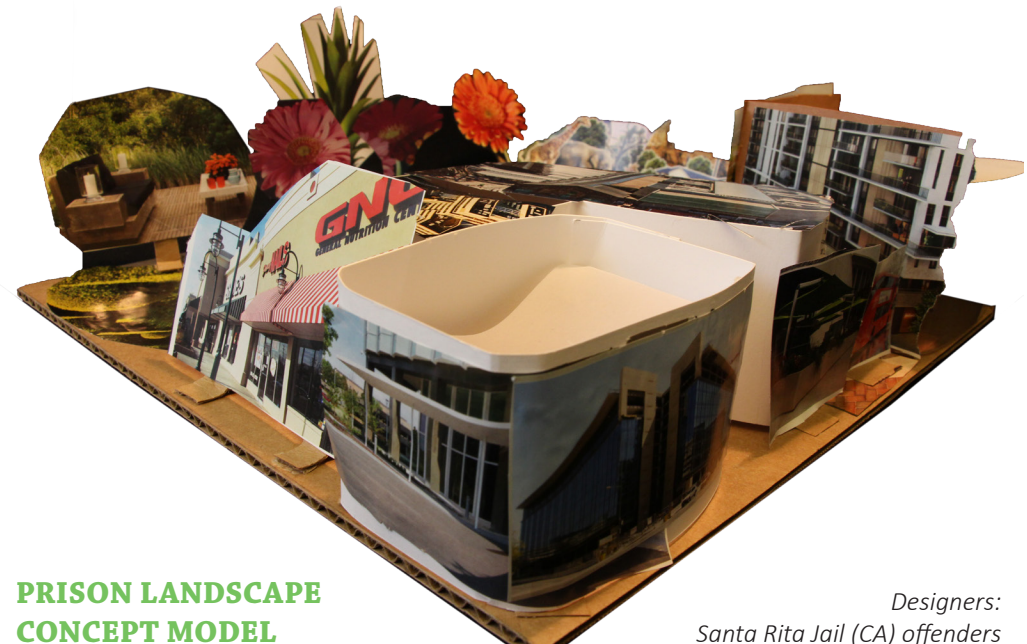

**PRISON LANDSCAPE CONCEPT MODEL**

*Designers: Santa Rita Jail (CA) offenders*

## Design SURVEY



During or after completion of your concept & program drawings, you will need to record the site's dimensions in order to make precise design decisions, and to represent them accurately. Broadly, this concept is understood as "surveying" a site. Survey can even be completed prior to concept design, and often naturally compliments the process of Site Analysis as described in the Pre-Design section.

Site survey is most easily accomplished by "pacing" out on a site. An average pace is between 2.5' - 2.75', but begin by measuring your own pace prior to arriving on the project site. Count your paces from one point to another, do some quick conversion math and you'll soon have fairly accurate measurements. Record the distances and dimensions of all existing features in your site (paths, structures, utilities, plants, fences, etc.) from a "point of beginning," or consistent reference point. Having a calculator available helps expedite the process. If you can access a measuring device, use it to double check your pacing calculations, but know that most commonly available tape measures are often too small to measure at the landscape scale. Be thorough & meticulous, taking good notes throughout the process. These efforts will make future design phases easier. In the present, this activity can help you make key design decisions that are still unaddressed at the concept stage.

### ESTABLISHING A POINT OF BEGINNING

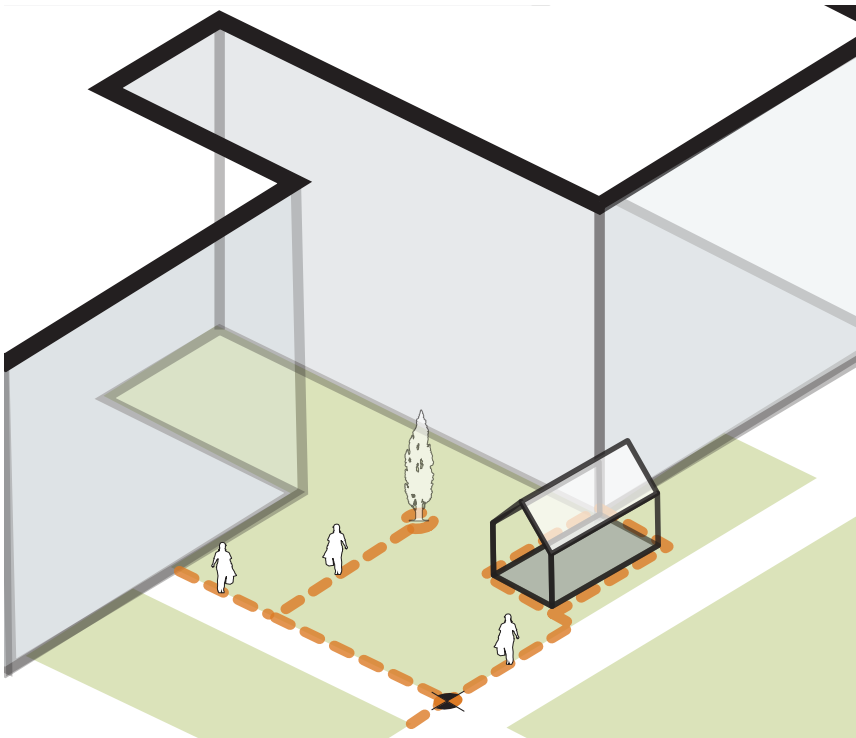

### CALCULATING DISTANCE BY PACING

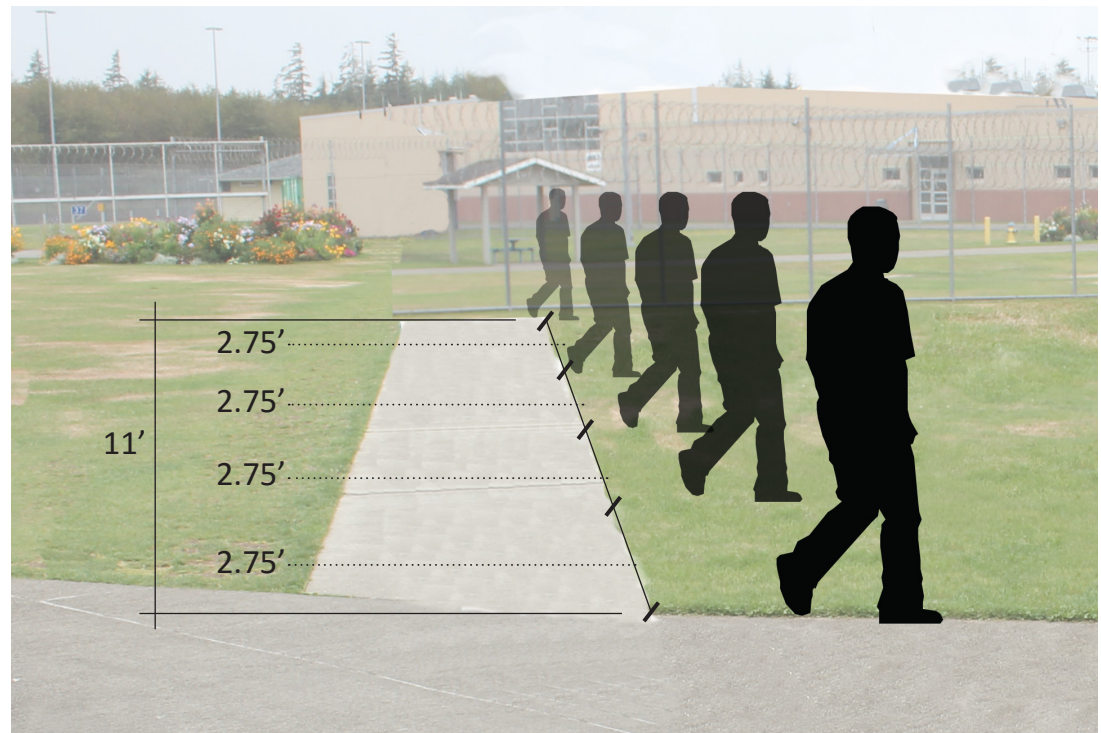

## Design

## MARKING &amp; MASSING



Massing & marking can be thought of as designing in place. The ultimate goal of this exercise is visualize the 2D and 3D realities of a proposed landscape project in the actual site. In the 2D realm, use grass chalk or marking paint to trace outlines of elements proposed in your project. Think of it as drawing a concept plan on the ground, but this time more true to scale and tied to place.

Massing is a similar activity but uses 3D elements to visualize the approximate volumes of proposed landscape elements. Any 3D object will work fine for massing. Most commonly used are plants in pots and overturned cardboard boxes to approximate for seating, tables and other structures.

Massings and markings are not intended to be permanent, and may need to be repeated during the construction phase to identify the work areas (this is particularly true of marking). Assume that clean up will be required shortly after completion of this activity, unless otherwise specifically permitted by the Project Manager.

### MASSING WITH VEGETATION & OTHER 3D ITEMS



### MARKING OFF A DESIGN IN A SITE

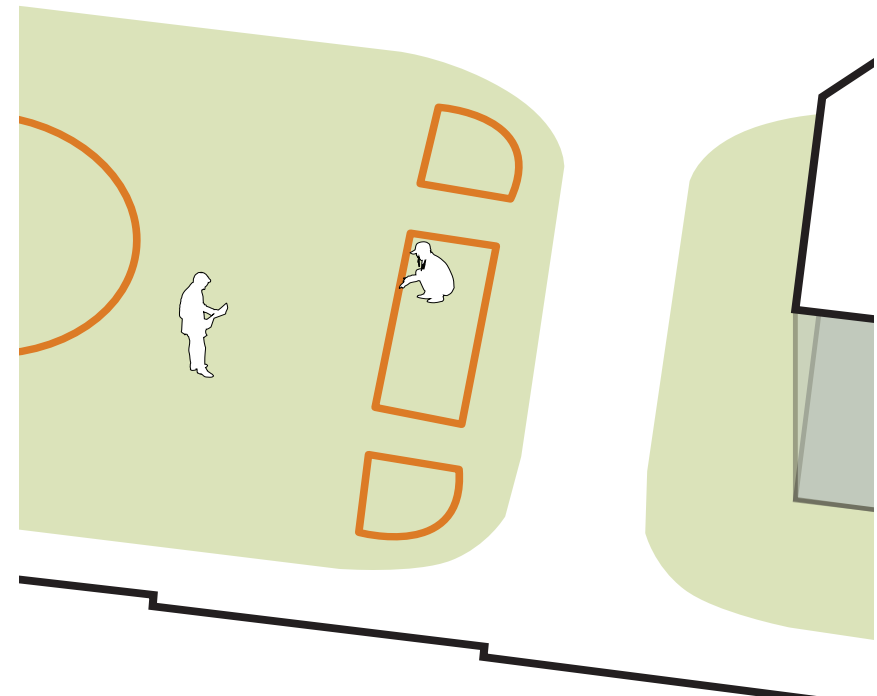

## Design SCHEMATICS



Depending on the “completeness” of your concept plans & models, as well as your massing and marking activity, your Project or Construction Managers may require a phase of schematic design. Schematic design drawings contain more information than concept drawings, and speak visually to the project’s materials, colors, and precise arrangements and size in space.

Schematics are done “to scale” and strive to achieve photorealism. Working from your survey notes, use an established scale to produce a plan drawing that is spatially accurate. 1”=16” works well with a standard ruler, as every 1/16 inch = 1 foot. Notes can be made on the drawing to explain details too small to depict graphically, as well as to describe the measurements of an element. You can also use a “key,” similar to those found on maps, to describe similar fine details in a way that minimizes the amount of text on the drawing.

Sections, or cut-through drawings, illustrate vertical relationships and depict the site at the scale of the human body rather than from above. Using 1/8” = 1’ and 1/4” = 1’ will help you zoom in to more easily draw those details.

Amazing artistry is not required for schematic design, but clear, lifelike graphics do help better illustrate ideas. Look to books in the library as well as any art-related educational programs at your facility to help your schematic efforts.

### SECTION DRAWING OF OUTDOOR CLASSROOM AREA IOWA CORRECTIONAL INSTITUTION FOR WOMEN

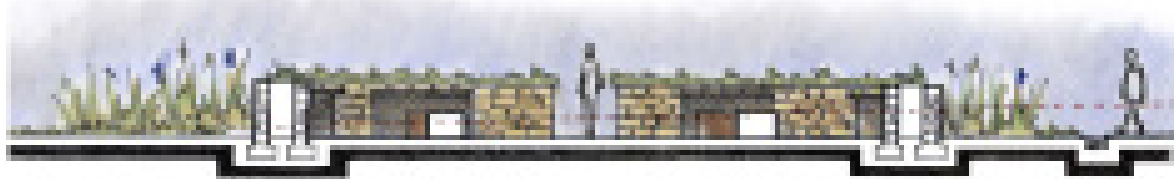

Designers:  
Garret Munch & Nicholas King

### GREENHOUSE GARDEN SCHEMATIC PLAN RIKERS ISLAND JAIL

Designers:  
Rikers Island Jail offenders

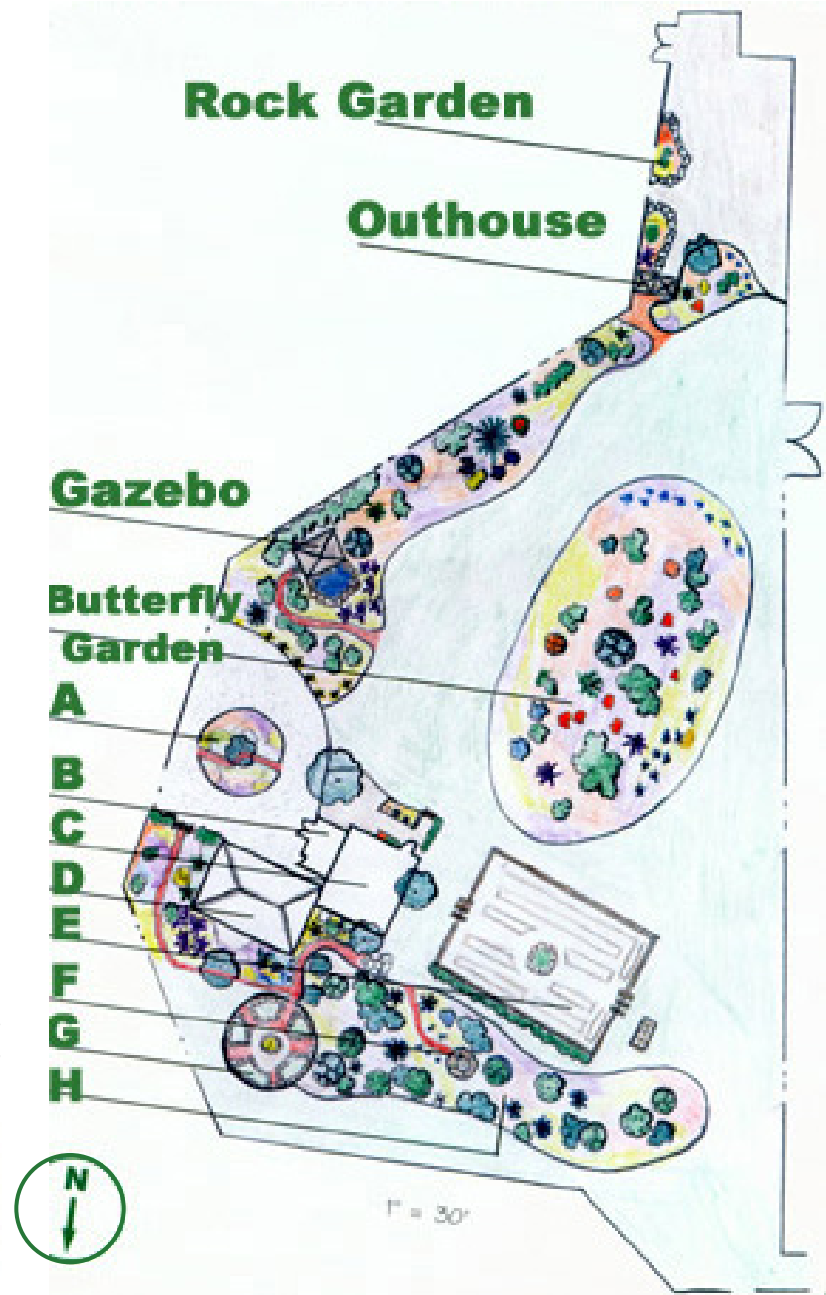

**SCHEMATIC DESIGN FOR SOU COURTYARD GARDEN  
MONROE CORRECTIONAL COMPLEX**

Designer:  
Amy Lindemuth



## Design

# CONSTRUCTION DRAWING



Depending on the complexity of your project, your managers may require construction drawings (CDs). The “final” stage of design, construction drawings communicate project details to those tasked with installing it. All forms and shapes should be completely spatially accurate, properly located and drawn to scale. Items, material types, and quantities should be noted in detailed annotations. Construction drawings are done in both plan and section. Oftentimes, construction drawing sections are zoomed in to illustrate only a single element. These drawings are also called “details.”

While highly accurate, construction drawings are also very diagrammatic, as they communicate technical information. You may have the chance to review past construction drawings for your site as part of your Site Analysis. This will likely require some interpretation, and you should work with your Project and Construction Managers to help you understand what the drawing is telling you.

WDOC has terrific construction drawing resources available in house. Correctional Industries offers Computer Aided Drafting (CAD) Services to the public to produce construction drawings. Collaboration with them will be necessary if your managers determine the need for CDs. Additionally, many of the groups addressed in the “(Potential) Partners & Resources” section are well equipped to assist non-professionals with construction drawing (see pages 17-18).

### EXAMPLES OF CONSTRUCTION DETAILS

Designer:  
Graham Golbuff

NOTES:  
1. NO STAKING REQUIRED.  
2. SEE STD. PLAN NO. 424 FOR TREE PIT DETAIL

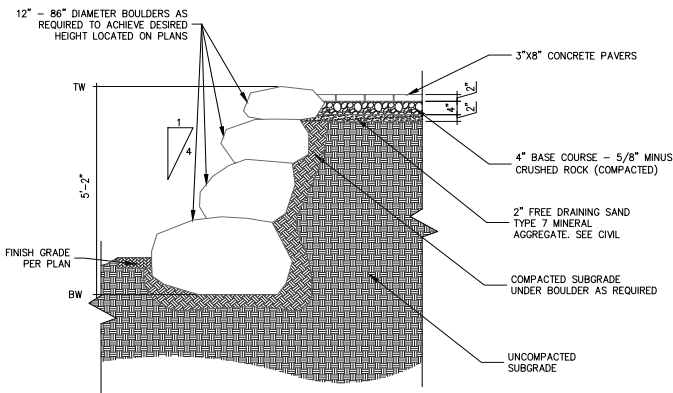

1 BOULDER\_RETAINING\_WALL  
L&O 3/4"=1'0" SECTION

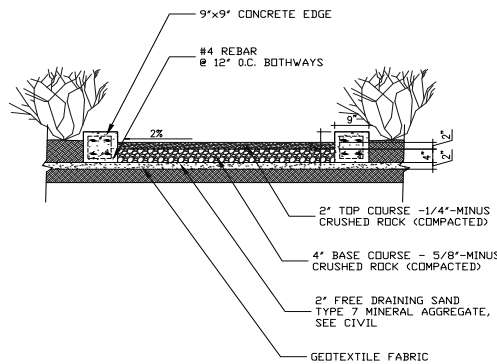

9 PATH\_DETAIL  
L&O 3/4"=1'0" SECTION

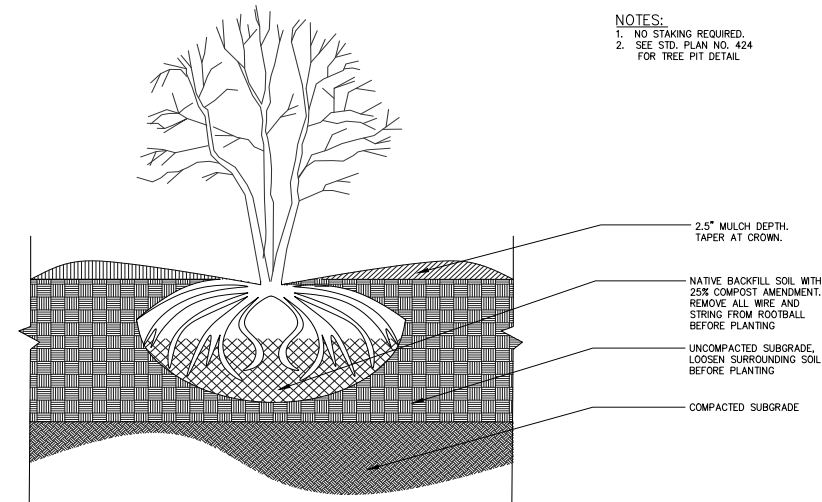

13 SHRUB\_PLANTING\_DETAIL  
L&O 1-1/2"=1'0" SECTION

SITE PLAN CONSTRUCTION DRAWING EXAMPLE

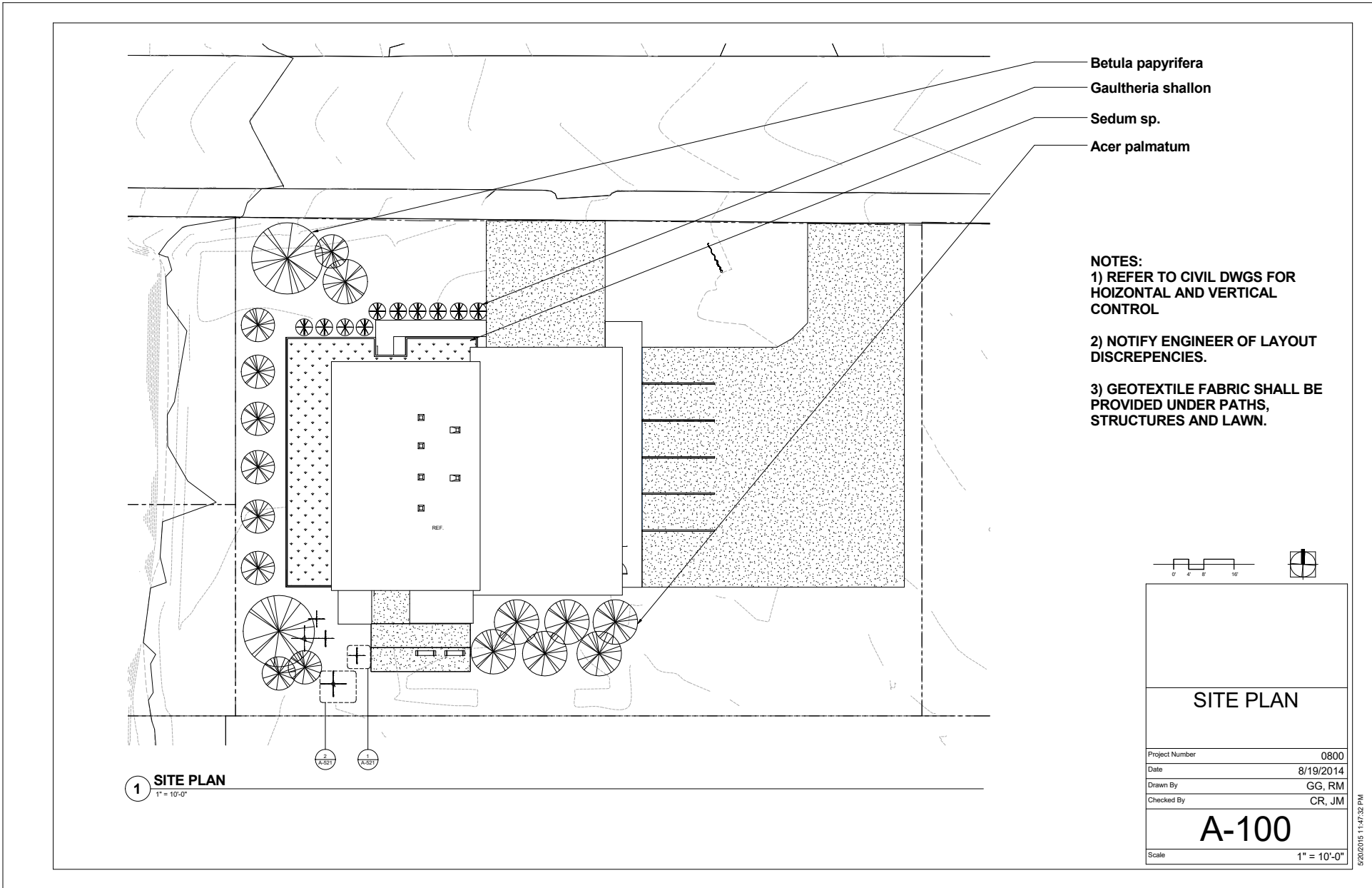

## Design

### *VISUALIZATION: SUSTAINABILITY*

---

Another useful tool in the design process is the perspective drawing. These are not “measured” drawings like plans and sections from which one can determine dimensions of various elements in the design; rather, perspectives evoke the character and ambiance of a place by placing the viewer in the scene.

Perspectives are excellent means to develop design ideas as well as to present them. They can be utilized at any point during the design process. Sketching ideas over photographic prints of existing conditions is a great way to begin conceptual design.

The following pages depict a number of visualizations of prison landscape interventions around a particular theme or concept. All images adhere to the Design Guidelines addressed earlier in these pages. They are intended to provide inspiration and give you a sense of what is possible in prison landscapes.

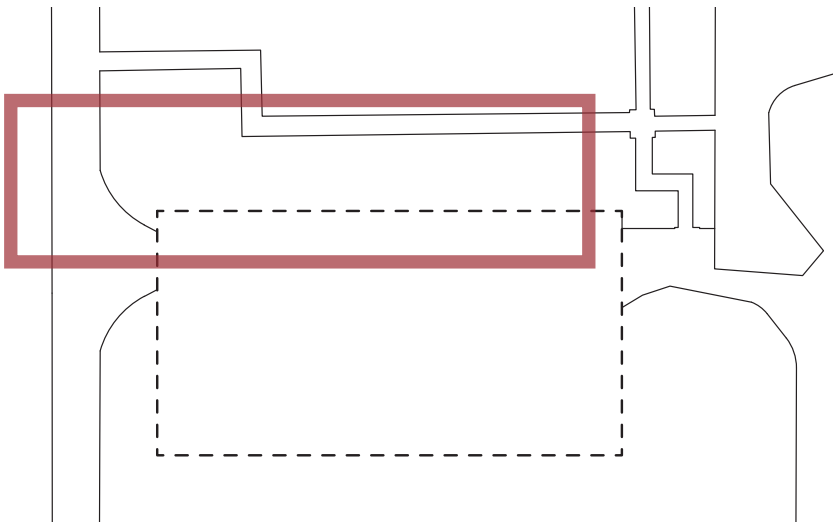

### **WATER CAPTURE (RAIN BARRELS)**

---

### **RAISED BEDS FROM RECYCLED MATERIALS**

---

### **FOOD GARDENING**

---

### **WATER QUALITY IMPROVEMENT CHANNEL (BIOSWALE)**

---





**STONE  
SEATING**

**GEOMETRICALLY  
ARRAYED  
FLOWER  
BEDS**

**STONE PATH**

**GRAVEL PATHS**

## VISUALIZATION: CUSTODY UNIT COURTYARD

The forms of many custody units allow for small pockets of space that can be converted to create a sense of privacy and personalization. Custody unit courtyards add value to those who experience them directly (outside), as well as from within and can see the landscape through a window. They build community and become a common cause for offenders in a particular unit to rally behind and collaborate in together.

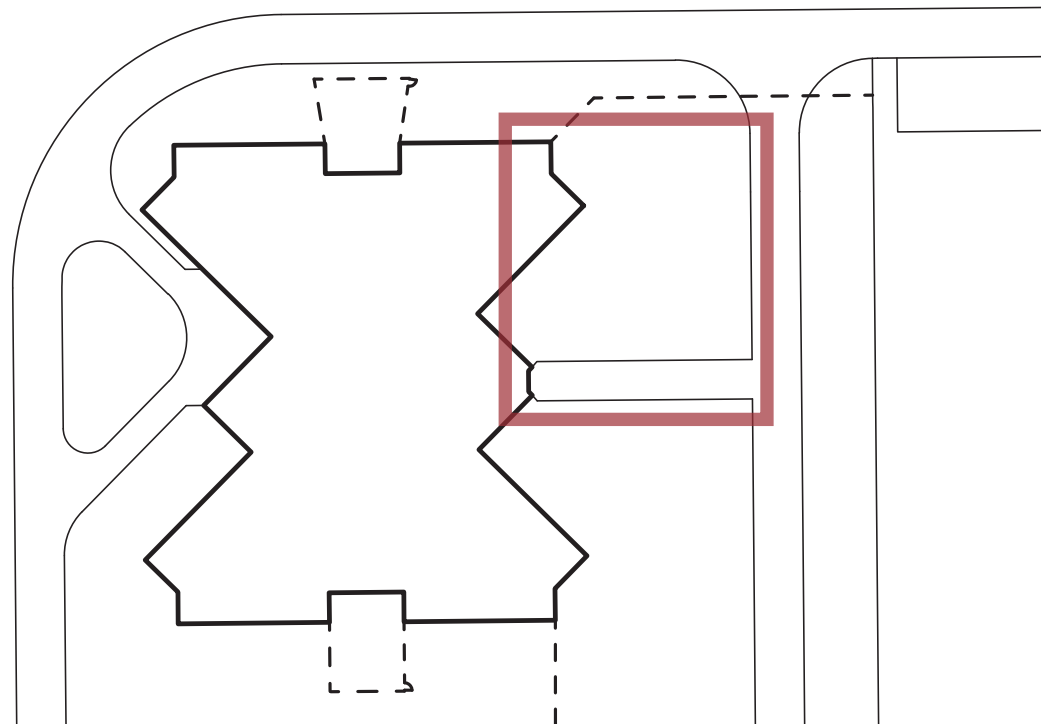

## Design

### VISUALIZATION: OUTDOOR RECREATION AREA

This concept attempts to take activities that have traditionally occurred inside, such as playing games or conversing, and creating space for them to occur outdoors. The scene depicted here allows for significant crafting and fabrication opportunities, which provide job skills, and help maximize opportunities for pro-social behavior among offenders.

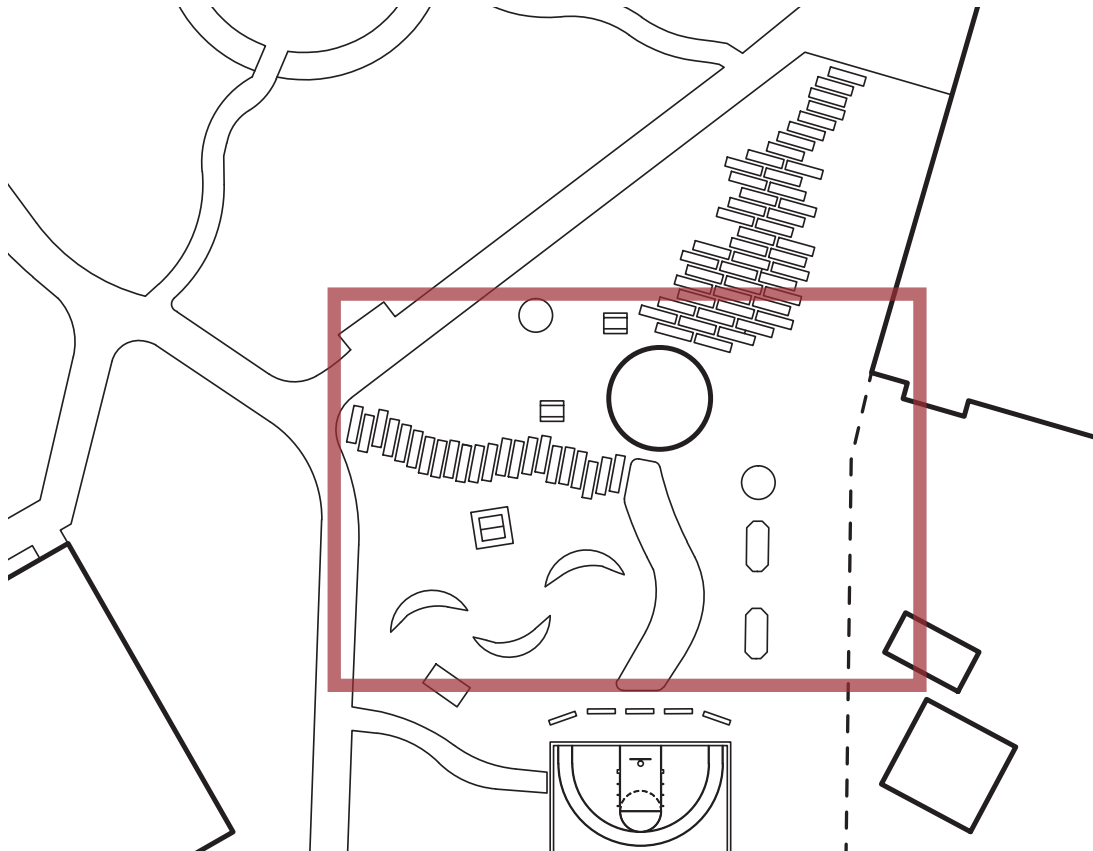

**IN GROUND  
PLANTINGS**

---

**RAISED  
BEDS**

---

**GAME  
TABLE**

---

**TREES**

---

**PICNIC  
TABLES**

---

**GAZEBO &  
SEATING**

---

**STONE PATH**

---



# CONSTRUCTION



*Construction team members installing raised beds for a plant nursery at Washington Corrections Center.*

# Construction

## PREVENTATIVE PRE-PLANNING

Your idea has moved through the design phase and has been given approval for construction by the Project Manager, Construction Manager and Owner Representative.

Before any work starts, the Project Manager will need to recruit a construction team, ensure access to proper safety equipment and provide a preventative safety training to the crew.

Construction teams should be recruited through standard program and work placement channels that occur during offender intake processing (FMRT). A short list of universally applicable safety equipment for any job is depicted on the right. Because of their ubiquity, these items are perhaps the most frequently forgotten once the construction process begins, so extra effort and attention to ensure access to them is critically important.

The Project Manager should conduct general job safety training any time a new individual begins on the project crew. Training should cover standard work protocols such as how tools are handled and how crew members can properly enter and exit the job site. Broad level information from the US Occupational Safety and Health Administration (OSHA) and WDOC environmental health and safety personnel should also be included in these trainings. Equipment or technique specific training should be led by the Construction Manager on the job site on as needed bases prior to operating the equipment or performing the technique.

### UNIVERSAL SAFETY “MUST HAVES”



Ear Protection



Eye Protection



Hard Hats



Sunscreen



Gloves



Drinking Water

### INTRODUCTORY SAFETY TRAINING



## Construction

### SUPERVISION & CREW MANAGEMENT

When working on landscape scale projects in prison environments, there may be a need for supervision that exceeds standard protocols for other offender jobs or programs. The following scenarios have been established using a combination of best practices from past WDOC projects as well as other innovative prison landscape projects from around the country.

If a construction crew is composed of up to three offenders, only one supervisor needs to be present. This supervisor would usually come from the facility's maintenance department. It could be the project's Construction Manager, or simply another maintenance staffer. If the crew is between 4-10 offenders large, at least two supervisors need to be present. In addition to the maintenance staff member, a custody officer (CO) should be available to help provide oversight. The CO could be the Project Manager, or any officer.

The flexibility concerning "who" these supervisors must be allows for staffing flexibility and prevents the managers from being overworked.

As crew size increases, continue to increase supervision as per this framework (3 supervisors for 10-13 person crew, 4 supervisors for every 14-20 crew, etc.).

*Crew supervision at Iowa Correctional Institution For Women  
Photo: Alison Weidemann*



#### **1 SUPERVISOR (MAINTENANCE)**

For 3 person  
construction crew



#### **2 SUPERVISORS (MAINTENANCE & CUSTODY)**

For up to 10 person  
construction crew



## Construction

# TOOL & MATERIAL MANAGEMENT

If the landscape project adheres to the supervision program addressed on the previous page, tool access for construction crew members is fairly unrestrictive. Two tools that can not be used by crew members however are box knives and hydrant keys. Supervisors should make all necessary cuts and provide water access when appropriate.

Tools should be inventoried at the beginning and conclusion of each work day, after crew members arrive on the site and before they leave. Project & construction managers should label all tool types with unique numbers. Throughout the day, supervisors should hold periodic “role calls,” asking for the location of, say, hammer 4 of 6. This will help cultivate a sense of sacredness around tools and improve overall facility safety. Tools should be stored in a controlled, monitored area. Only the necessary tools for the day’s work should be brought out to the job site each day. All other tools should remain in storage.

Coordinating the delivery of materials and stockpiling it on the job site is a complex endeavor for any construction project, but is especially difficult in prison settings. Construction Managers should lead this process and be sure to provide vendors with as detailed information as possible when arranging delivery of materials. Any materials stored on site should be in a secured area with no movement or activity outside of supervised landscape construction work.



*Staging soil within a secured area at Washington Corrections Center*



## Construction

# SEQUENCE & CONSIDERATIONS

The remainder of this section is meant to give a broad introduction to the general sequence of construction tasks on any landscape project, as well as to address considerations that are unique to prison contexts for that particular phase of construction.

*Construction of Outdoor Classrooms at the Iowa Correctional Institution For Women*

*Bob Elbert*



# Construction

## 1) DEMOLITION

Most any landscape project begins with clearing a site of features that are not to remain. This helps improve the project's overall efficiency by allowing for materials to move more easily through the site, but can also be environmentally destructive if not considered wisely.

Items that are commonly demolished include structures, paths & vegetation. Trees should only be demolded if absolutely necessary.

When possible, it is ideal to demolish by hand rather than by vehicular equipment, which helps reduce overall environmental impact.

Tools used in this process include picks, digging bars, shovels, saws & hammers. Vehicular demolition equipment includes bulldozers & excavators.

Under supervision, offenders can participate in any manual demolition activity. They can not operate vehicular equipment, and should be assigned work in other project areas while those operations are occurring.

Example of a demolition plan in a construction drawing set.

Designer: UW Landscape Design/Build Studio

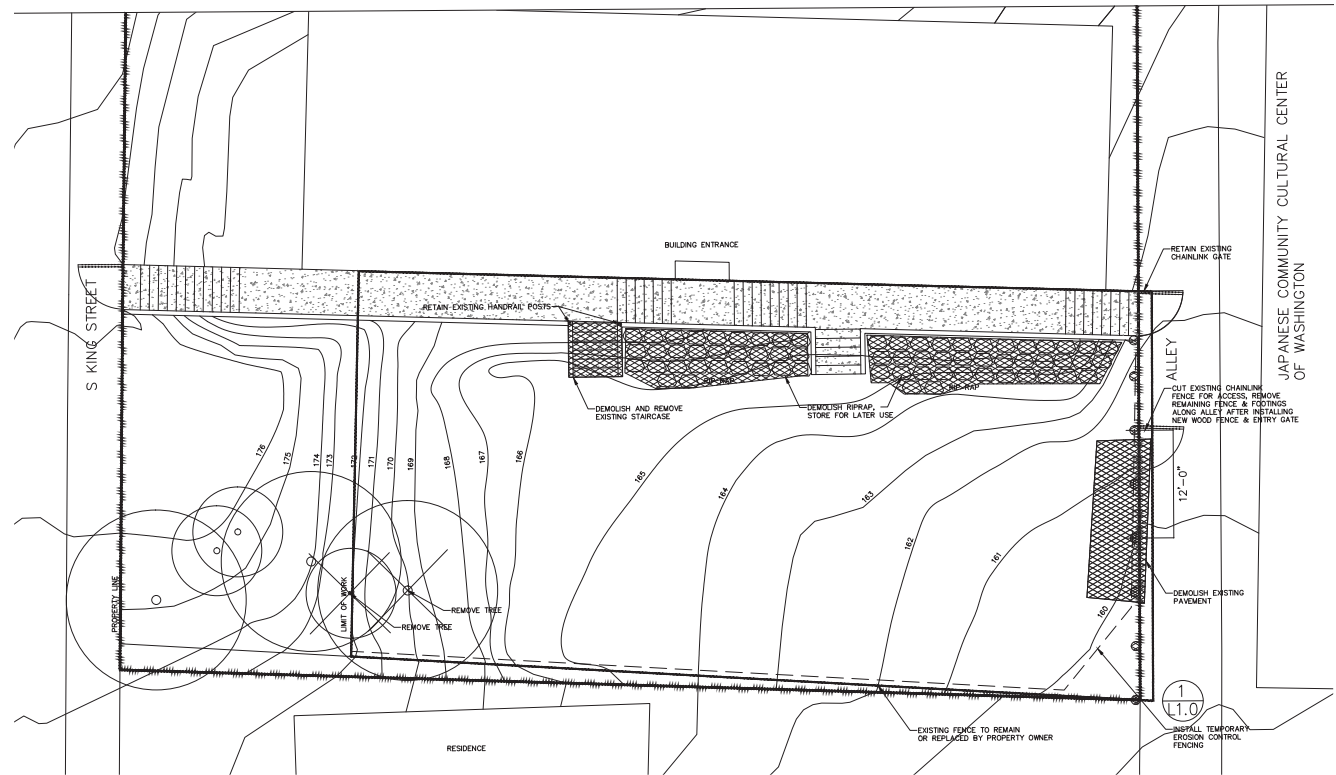

## Construction

### 2) ROUGH GRADING

In creating landform or topographic variation, a site undergoes rough grading. Earth is “cut” to create depressions and low points, and “filled” to create mounds or high points. To maximize sustainability, rough grading aims to equalize the amount of earth that is cut and filled. This reduces the quantity of material that needs to be imported or exported from the site and minimizes overall disturbance. Calculating the equalization of cut and fill happens during the creation of construction documents.

Rough grading is typically accomplished by vehicular equipment like bulldozers and scrapers. As WDOC landscape design guidelines only permit a 12” topographic variation, rough grading for prison landscape projects can occur manually with shovels, digging bars and rakes.

*Cutting & filling of earth on a job site during rough grading*

*Pacific Coast General Engineering*



# Construction

## 3) EXCAVATION

*Manual excavation to establish a reflecting pond*

*Jackson's Landscape Design*



After your project's general topography has been established, any digging for trenches, foundations, footings, steps and other landscape features should be accomplished at this time. This step is broadly referred to as excavation.

Due to the precision that most excavated areas require, excavation is best completed manually. In addition to picks, shovels and digging bars, rototillers, sod cutters and augers may be helpful at this stage to loosen compacted areas.

After areas are excavated, they should be clearly marked with marking paint, caution tape, flags and other fluorescent materials.

Like the demolition stage, under supervision, offenders can participate in any manual excavation activity, even when potentially dangerous tools are involved.

*Rototiller*



*Sod Cutter*



*Auger*



## Construction

### 4) DRAINAGE

Drainage features may become part of your landscape project, particularly when renovating a field, installing a water feature or a bioswale. Drainage infrastructure construction typically involves both “built” components and natural features such as topography and soils. General site drainage strategies include infiltration (absorption by soils & other natural media), detention (collection and subsequent release), and retention (capture & storage). Many projects employ multiple drainage approaches at once.

After drainage feature areas have been excavated, infrastructure like piping and catch basins are placed for detention and retention approaches. For infiltration approaches, the excavated areas are amended with compost and other organic materials.

One type of drainage infrastructure that deserves special attention in a prison setting is an area drain. Found in both vegetated and paved areas in landscapes, area drains feature exposed grates that allow water to percolate into a pipe or basin for retention or detention. In prison landscapes, grates must be fastened to their below ground component rather than simply left in place and secured by their weight and gravity.

#### INFILTRATION

Bioswales, Rain Gardens,  
Porous Paving

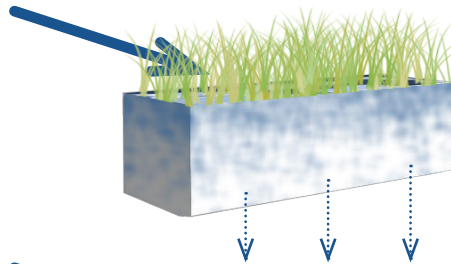

#### DETENTION

Catch Basins, Cisterns



#### RETENTION

Cisterns, Ponds,

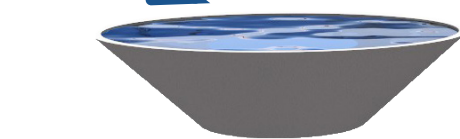

#### SECURING AN AREA DRAIN

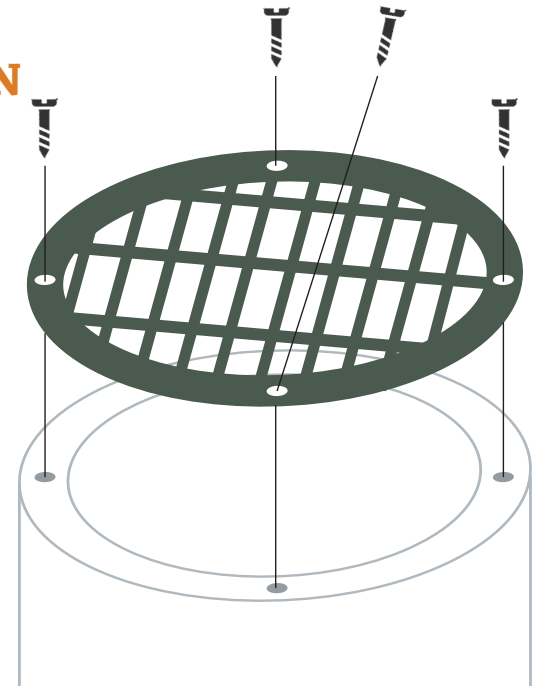

## Construction

### 5) CONCRETE

The most widely used building material in the world, concrete is remarkably durable and versatile. In landscape contexts, concrete is primarily used as a material for a foundation or footing for a structure, as media for a path or floor, or in a functional or sculptural context, such as a bench or table. Under supervision, offenders can participate in all aspects of the concrete construction process.

Concrete is made by mixing cement, an aggregate (typically sand and/or crushed stone) and water. It is then poured into a wood, metal and plastic mold (“form”) and left to solidify (“cure”). Forms are then deconstructed, leaving behind only the concrete. In many cases, other materials such as rebar and metal brackets are set into the concrete after it’s been poured into a form to either improve the material’s tensile strength or as a means to connect other materials later on. Concrete is typically installed in excavated areas that have had a layer of crushed stone applied (“subbase”) and then compacted before the form is set into the excavated area and before concrete is poured into the form.

Concrete has remarkable thermal mass, meaning that it retains heat well. At the same time, concrete also requires significant thermal energy inputs to warm from ambient temperatures. Thus, concrete plays an important role in the creation of microclimates on a site. It is also an important consideration in specifying it as a material for functional purposes. If used as a bench and placed in direct sun, will it get too hot for people to sit on? Finally, concrete can be made artful and intriguing by the formwork itself, or by applying unique finishes and scoring patterns into the concrete while curing.



## Construction

### 6) STONE & MASONRY

Stone & masonry units like bricks or pavers have a variety of applications in the landscape. Broadly, they can be used to make seating, paths, planting beds, and (when large enough) individual sculptural elements. Individual stone and masonry units (think “pieces”) can be assembled by “dry” (without a binding agent), or “wet” (with a binding agent, typically mortar) techniques. Which technique you’ll use will ultimately depend on your materials and desired feature or structure.

Individual stones are commonly measured by “men” units, that is, how many individuals it would generally take to move and place the unit. For individual, dry laid stones in prison landscapes, the units must be no smaller than 4-man. Stones of this size are best placed manually, using digging bars and wheelbarrows.

In assembling structures from smaller stone and masonry units, such as for seating or planting beds, epoxy has been found as an effective binding agent in prison landscapes. This reduces the need for mortar and accompanying training, which ultimately allows for more individuals to be involved in the construction and improve the project’s overall efficiency.

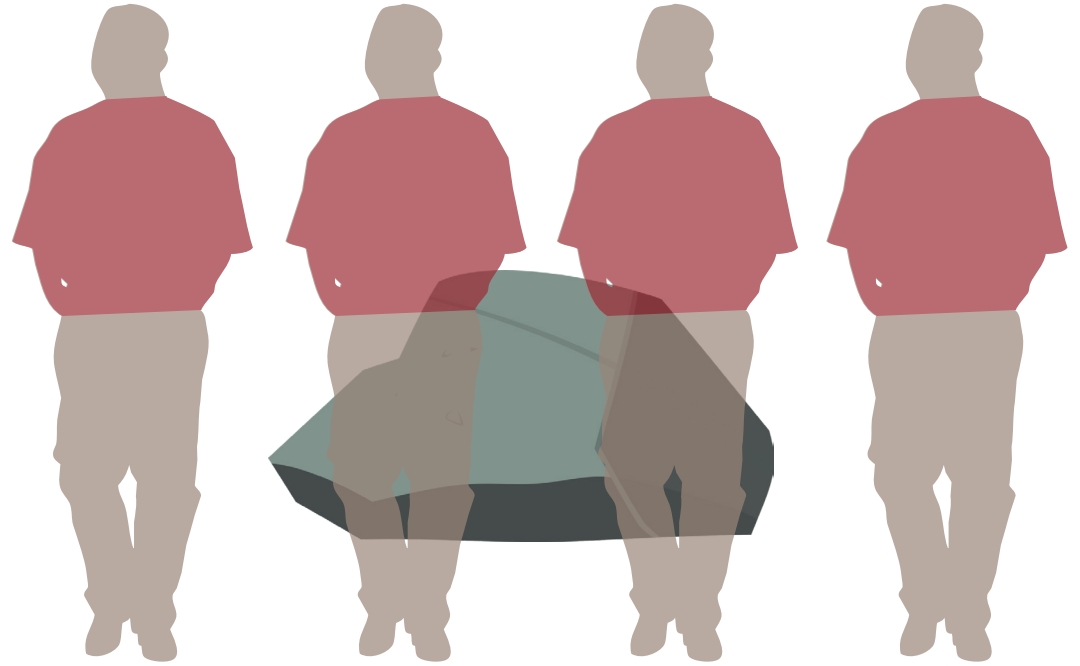

*Epoxy & dispenser*



*Stone seating & planters*

*Bob Elbert*



Construction

7) FINISH GRADING

At this point, all digging has been completed and the majority of heavy items that can shape topography by virtue of their mass, such as concrete and stone, have been placed. The next step in the sequence is to establish finished grade for final site modifications.

Finished grades are the intended, precise surface elevations across the entire project site. Unlike rough grading, finish grading is much more precise and is best achieved through manual means. Check elevations with a transit level and grading rod, and sculpt terrain accordingly with a landscape rake.

Finish grading a stair landing with a landscape rake

Shih-Chia Chiu



Checking final elevations

Shih-Chia Chiu



Transit Level & Grading Rod



Landscape Rake

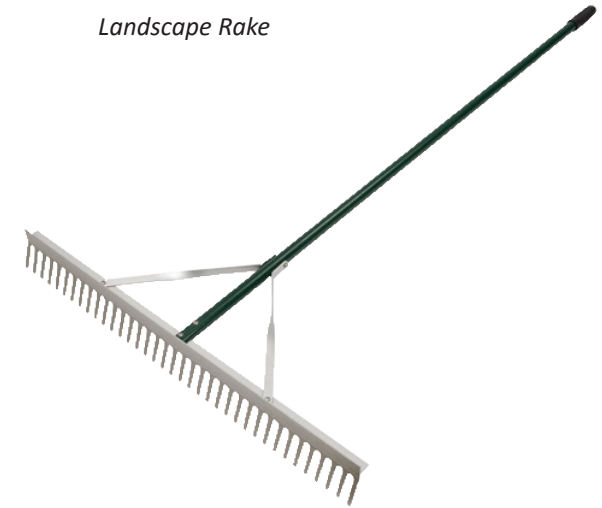

## Construction

### 8) CARPENTRY

Wood is a versatile material in the landscape, and due to its organic nature & human scale, it possesses an inherent warmth and inviting quality that few materials can match. It is also comparatively easy to work and allows for fine craftsmanship. Primarily a structural material, wood is typically used in structures and furnishings in prison landscapes. Sheds, garden beds, shelters, and specialty paths can all be constructed from wood in prison environments.

Many wooden landscape elements can and should be constructed off the job site in WDOC maintenance or educational program shops. In selecting woods for prison landscape projects, fir and cedar are recommended due to their local availability and inherently long lives through natural preservatives in their tissues.

*Wooden bridge over pond at HM Prison Whatton, UK  
prolandscapingmagazine.com*



*Artful trellis in garden at Halden Prison, Norway*

*Marte Aas*



*Carpentry shop in action at Crowley County Correctional Facility, CO*

*Cyrus McCrimmon*

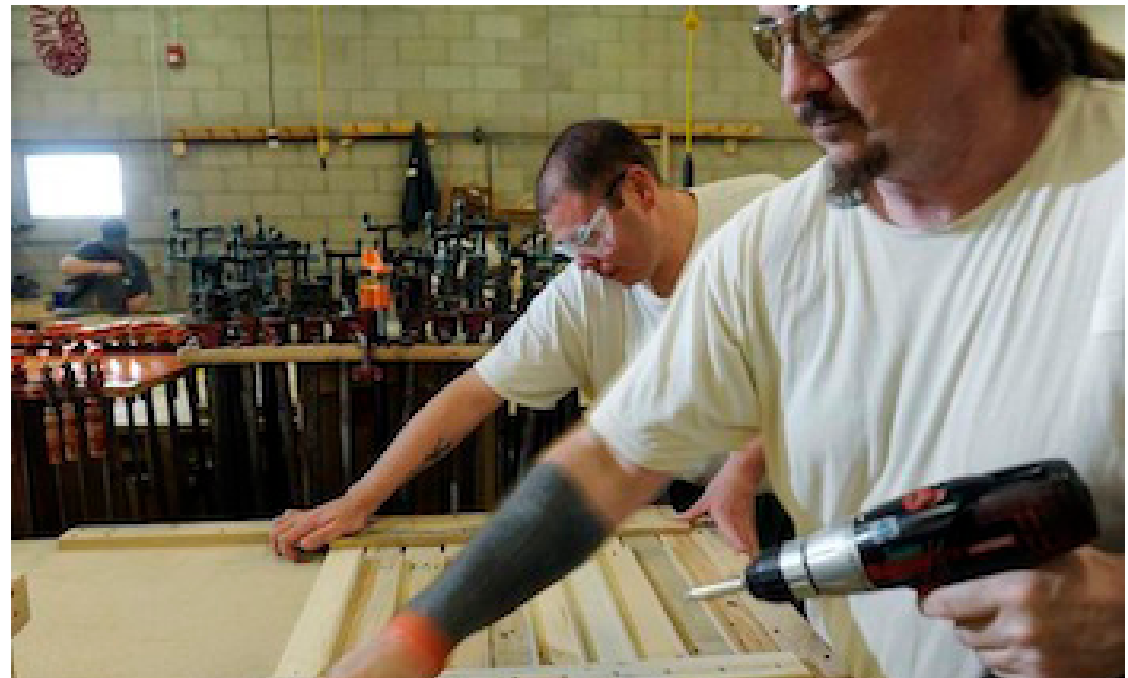

**Construction**

**9) METAL WORK**

Though their fabrication can take place concurrently with any other phase of the construction sequence, metal elements are the final pieces that are installed in a prison landscape. In prison landscapes, metal is primarily used as a structural component or to connect different elements. Due to the inherently more technical nature of metal fabrication and construction compared to concrete, wood and stone, as well as related safety concerns, metal is generally discouraged in prison landscapes.

There may be times, however, when the use of metal is imperative, such as for a structural connection or a lighting fixture. In those cases, the key detail to working with this material in a prison landscape is to minimize the amount of connections that can be easily taken apart. This is to say that connections should be welded or riveted rather than assembled by traditional fasteners (bolts, screws, nuts, etc.).

**WELDED CONNECTION**

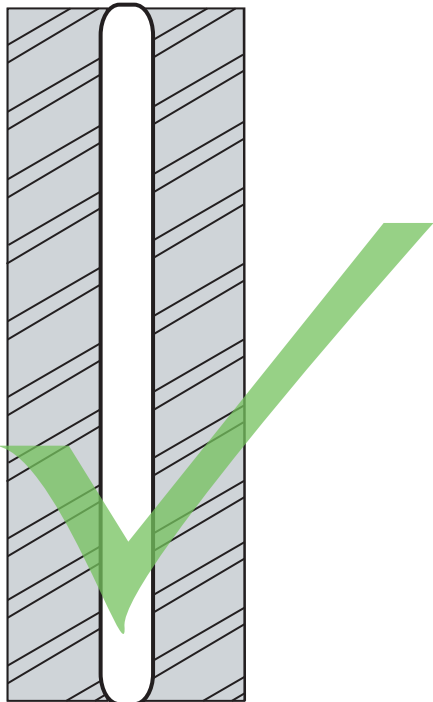

**RIVETED CONNECTION**

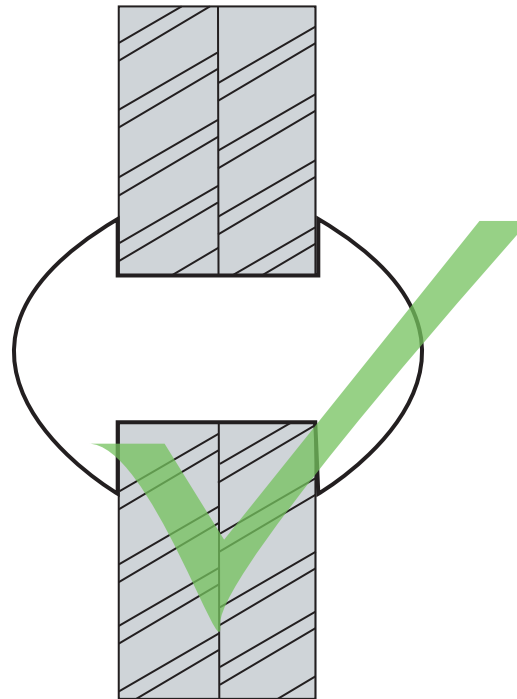

**BOLTED CONNECTION**

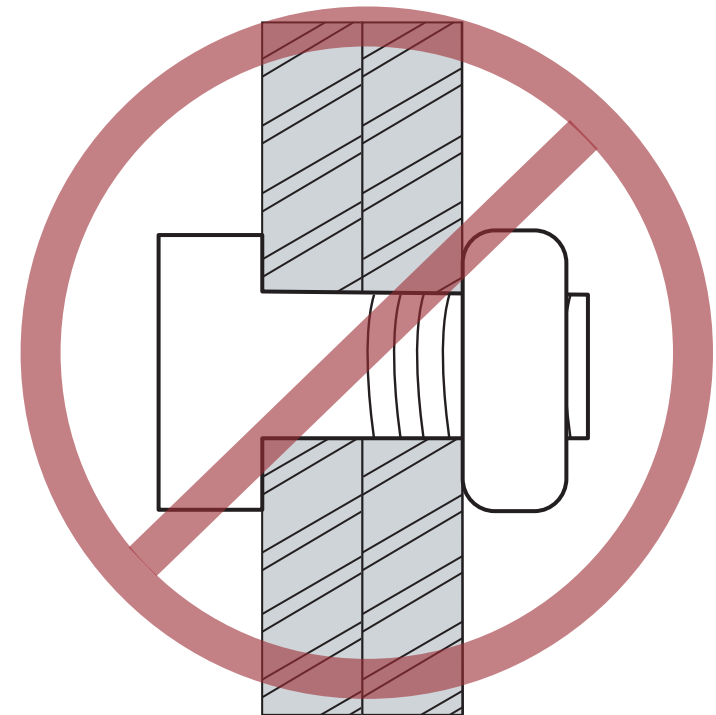

## Construction

### 10) PLANTING

Construction is nearly complete, and the project is beginning to look like a functional, enjoyable space. The last step to be completed in the construction sequence is planting. If possible, and if they haven't played a role in the project thus far, involve the grounds and/or horticulture programs at your facility to assist with or lead this activity. Hopefully they have some plant stock that they can contribute to the project.

General planting guidelines are as follows: Dig a hole that exceeds the plant's root ball diameter and loosen the soil on the sides and base of hole while maintaining its shape. Sprinkle some compost and worm tea or other organic fertilizer into the hole. Remove the plant from its container and rough up the root ball. Set the plant in the hole so that the plant's crown (where it emerges from the soil of the root ball) is level with the adjacent ground. Adjust the depth of the hole by filling in or digging out extra soil as needed. When the appropriate depth is set, place the plant and pack it down with light force to stabilize. Repeat the compost and worm tea application at the surface around the plant's crown, then lightly scratch it in as you did the root ball. Water the new planting "in" as soon as possible.

Under supervision, offenders can participate in all aspects of the planting phase.

*Greenhouse planting at Cedar Creek Corrections Center*



*Watering in a new raised bed planting of Viola adunca at Washington Corrections Center*



# POST-CONSTRUCTION



*Enjoying strawberry plants in a brick planter at Washington Corrections Center for Women*

# Post-Construction CELEBRATION

When your landscape project is complete, the first order of business is to celebrate and recognize your accomplishments! This is a great way to show gratitude to individuals, departments and programs at the facility that helped make the project possible. Having a celebratory or recognition event also helps build buzz for creating more enjoyable landscapes around a facility, resulting in an more positive environment for all.



# Post-Construction MONITORING & EVALUATION

As lots of energy and effort went into the creation of your landscape project, it may be appropriate to assess the benefits that your project yielded over time.

It is first important to define what you wish to monitor. For this, revisit your initial project goals. If creating wildlife habitat was an objective, doing periodic insect and animal counts would be an appropriate way to assess the effectiveness of meeting that objective. If you wanted to create a space for socialization and gathering, tracking how often it was being used by offenders would be an effective way at getting that information. In short, your methods will be defined by what you want to monitor.

The “who” component of the monitoring question can vary. Offenders may be able to participate if interested, though they might not be able to have continual access to the landscape that staff would have, which could compromise the quality of data collected. Project Managers should work with other custody officers on duty during movement or other outdoor times to see if they can help the project collect information.

When sufficient monitoring data has been collected, the Project Manager should work with the Construction Manager and Owner Representative to analyze the data and evaluate the overall value of the project. Evaluations can be repeated periodically, and if a particular project returns regularly poor results, that information can be used as grounds to adapt the site for different use in the future.

*Monitoring insect damage on leaves*

*Benj Drummond & Sarah Joy Steele*



*WDOC Project Managers evaluate landscape projects*



## Post-Construction MAINTENANCE

To ensure your project persists over time, a maintenance regiment should be established. Depending on what elements your project contains, maintenance could include painting, staining, washing, lubricating, sanding/grinding, compacting, pump cleaning, mulching, pruning, fertilizing and weeding.

The earlier in the process that the project considers the likely maintenance required, the better. This thinking ultimately helps inform design and construction decisions. Work first with your Construction Manager to establish a maintenance program & rate of recurrence.

The Project Manager should then reach out to specific maintenance teams (grounds, plumbing, hardscape, etc.) to ask if they'll take on maintaining the project as part of their regular work. If not, the Project Manager can consider lobbying for the establishment of a new crew that specifically cares for the newly created landscape project.

Regardless of who maintains the project in the long run, once the maintenance program is established, it should be documented. Offenders can help draft a maintenance manual for the project that details the program established by the CM, and work with the Project Manager to ensure the manual is archived and shared appropriately. Finally, offenders can apply to work on crews that maintain the created landscapes. These jobs are rewarding and benefit individual offenders as well as the greater prison community.

Routine garden maintenance at Washington Corrections Center for Women

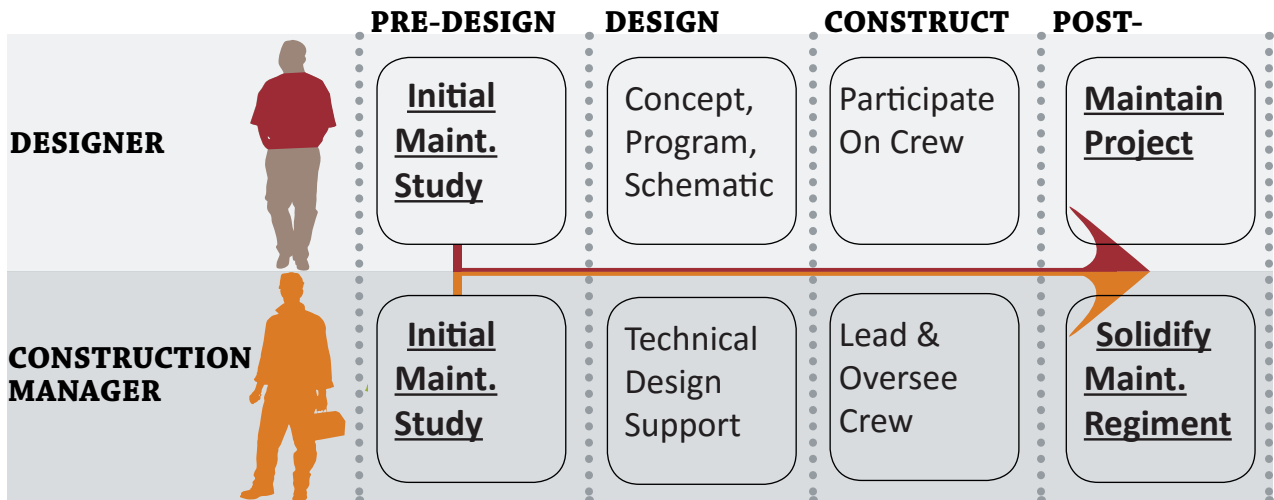



# GROWING WASHINGTON'S PRISON LANDSCAPES

## (invaluable) RESOURCES

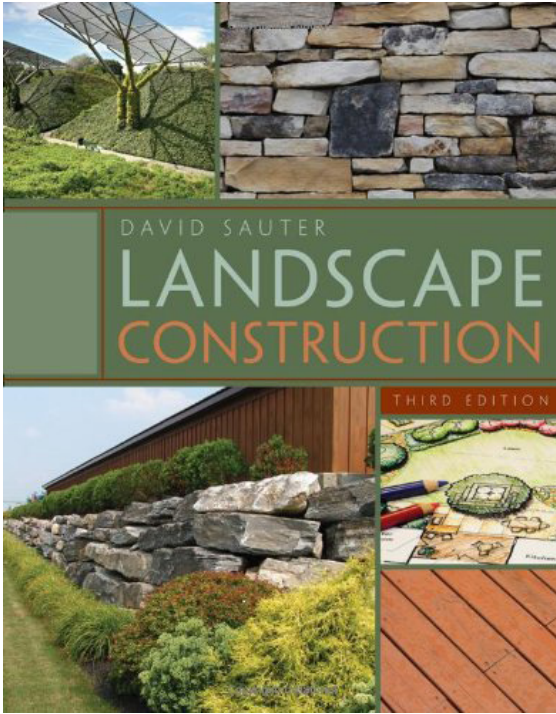

### **Landscape Construction**

by David Sauter

detailing,  
construction techniques,  
material properties

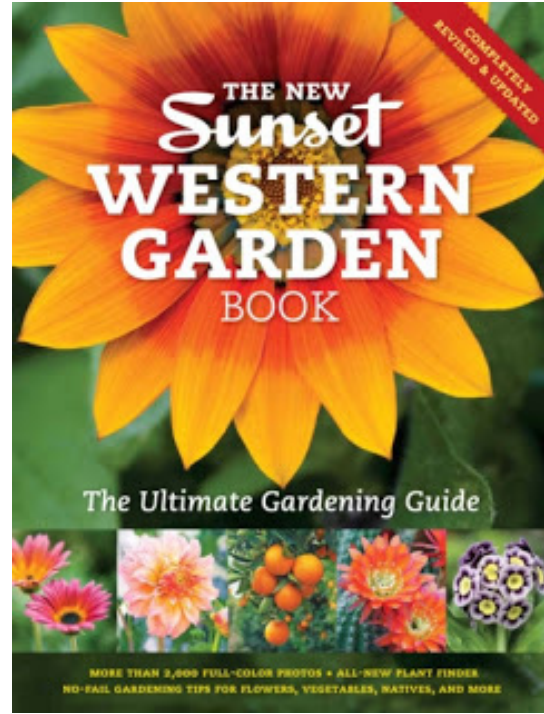

### **The Sunset Western Garden Book**

plant selection,  
design inspiration,  
maintenance requirements

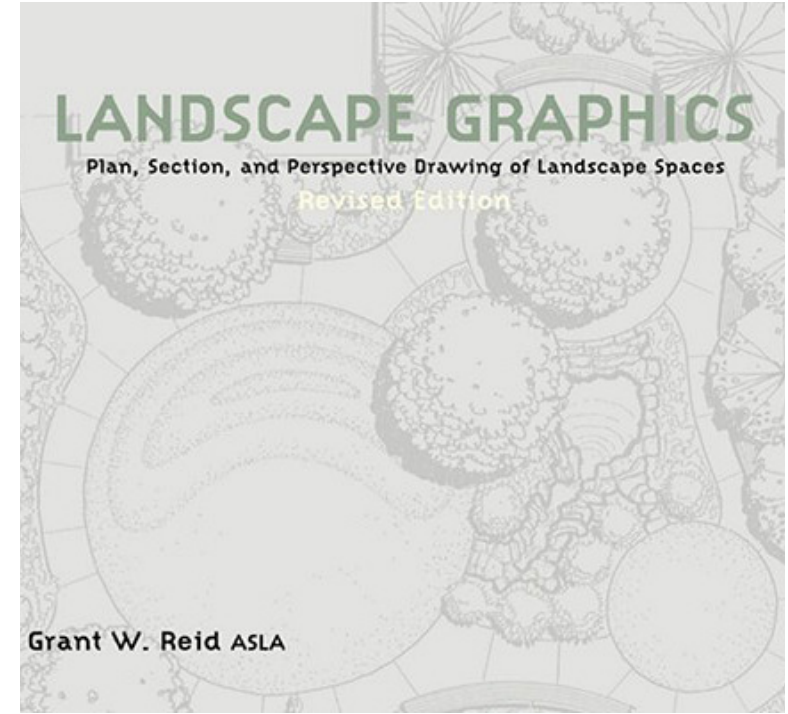

### **Landscape Graphics**

by Grant Reid

concept drawing,  
schematic drawing,  
graphic conventions

---

# WORK CITED

---

Alexander, Michelle. The New Jim Crow: Mass Incarceration in the Age of Colorblindness.  
New York City, The New Press. 2011.

Bouffard Jeffrey; Doris MacKenzie and Laura J. Hickman.  
“Effectiveness of Vocational Education and Employment Programs for Adult Offenders: A Methodology-Based Analysis of the Literature.”  
*Journal of Offender Rehabilitation*. 31: 1-2: (2000). 1-41.

Conover, Ted. New Jack: Guarding Sing Sing.  
New York City, Vintage Books. 2001.

Rhodes, Lorna. Total Confinement: Madness and Reason in the Maximum Security Prison.  
Berkeley, University of California Press. 2004.

Thigpen, Morris; Thomas Beauclair and Shelly Carroll.  
The Greening of Corrections: Creating a Sustainable System.  
Washington, DC, US Department of Justice. 2011.

Ulrich, Roger; Robert Simmons, Barbara Losito, Evelyn Fiorito, Mark Miles and Michael Zelson.  
“Stress Recovery during Exposure to Natural and Urban Environments.”  
*Journal of Environmental Psychology*. 11: (1991). 201-230.

Wilson, David; Catherine Gallagher and Doris MacKenzie.  
“A Meta-Analysis of Corrections-Based Education, Vocation, and Work Programs for Adult Offenders.”  
*Journal of Research in Crime and Delinquency*. 37: 4: (2000). 347-368.

Sustainability in Prisons Project  
Lab 2 2257  
The Evergreen State College  
2700 Evergreen Parkway NW  
Olympia, WA 98505  
(360) 867-6863  
[www.sustainabilityinprisons.org](http://www.sustainabilityinprisons.org)

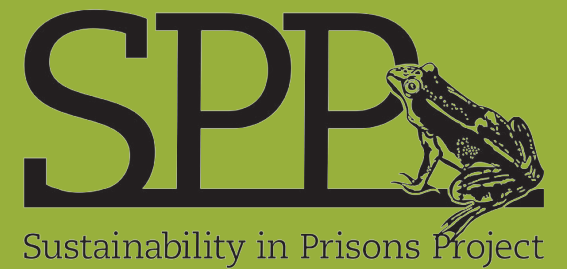



*this page has been intentionally left blank*

# REFLECTIONS

essays inspired by and influencing the work of

**GROWING WASHINGTON'S  
PRISON LANDSCAPES**

A Design & Construction Guidebook

by Graham Golbuff

*The following text contains the positions and opinions of the author alone, and do not necessarily reflect the official positions or opinions of any individual or entity involved in Growing Washington's Prison Landscapes, including the Washington Department of Corrections, the Sustainability in Prisons Project, and the University of Washington.*

## Context and Background to Involvement

In 2003, two separate but aligned events occurred at Cedar Creek Corrections Center (CCCC) in Littlerock, Washington. In a move to reduce the institution's operational costs and simultaneously offer green job training opportunities for offenders, then-superintendent Dan Pacholke initiated both a composting and water catchment program for the facility. At the same time, Nalini Nadkarni, a forest ecology professor at The Evergreen State College (Evergreen) in Olympia, Washington, was investigating the viability of growing native mosses whose stocks in the state's old growth forests had been decimated by harvest for the horticultural trade. Nadkarni reached out to Pacholke with the idea of offering offenders the opportunity to work as moss horticulture technicians in her experiments. Pacholke welcomed the proposal, and after securing funding from the National Science Foundation, 10 CCCC offenders were conducting rigorous scientific research that had direct beneficial impact on their backyard ecosystem.

Within a year, both projects garnered unprecedented success: including more cost savings than expected, significant press attention, experimental results suited for publication in peer-reviewed journals, and indications that CCCC was becoming a more productive and positive environment as a result of these efforts. Between 2004 and 2008, the partnership expanded their programs to 4 additional facilities within the Washington Department of Corrections (WDOC), resulting in similar successes. In July 2008, an inter-agency agreement between Evergreen and WDOC was completed and the Sustainability in Prisons Project (SPP) was formally established. Today, SPP oversees a myriad of sustainability programs at all 11 WDOC facilities, including the rearing of local endangered plant and animal species, bicycle and medical equipment repair services, waste reduction and recovery, and extensive "in-class" educational curriculum (Nadkarni and Pacholke, 28-29; Sustainability in Prisons Project, "History"). The mission of SPP is: *"...to bring science and nature into prisons. [They] conduct ecological research and conserve biodiversity by forging collaborations with scientists, inmates, prison staff, students, and community partners. Equally important, [they] help reduce the environmental, economic, and human costs of prisons by inspiring and informing sustainable practices (Ibid)."*

I first became aware of SPP during its initial startup years, likely before the program even had an official title. I was an undergraduate student at Evergreen between 2003 and 2007, studying ecology. While I never had a class with Nadkarni, I had friends who did, and at some point whispers of prison-based ecological work made their way to my ears. The concept captivated me. I admired the integrity of the project not just because of its ecological and sustainability rigor, but because it intentionally engaged a marginalized community. While I didn't have a language for it, I suspected that by providing offenders the opportunity to connect with nature, some offender betterment would result.

I left Evergreen in 2007, just before SPP was formalized and fully expanded across WDOC. In the years that followed, I had a few acquaintances go to work for SPP, while I simultaneously saw more media coverage of the organization's work. I knew the work being done in Washington's prisons was catalytic. For years I recall feeling immense pride in the fact that I lived in the state and received a degree from the institution that arguably kick-started the green prison movement in this country (Thigpen et al., 91-94).

In late 2013, half way through my Master of Landscape Architecture (MLA) degree, I fortuitously read an article in *Landscape Architecture Magazine* that profiled the work of Iowa State University professor Julie Stevens. That summer, she had led a design/build studio in creating an outdoor classroom space for the Iowa Correctional Institute for Women, rooted in concepts of therapeutic landscape design (Jost, 2013). Having come from the natural sciences, but having spent the last year learning the language of design, I became convinced that engaging offenders in design and construction could also help bring nature into prisons and further reduce their environmental, economic, and human costs, and ultimately meet SPP's mission even more efficiently. Taking inspiration from Stevens' work, I set out to help SPP build capacity for design and construction-based programming in their work.

From the outset, I was adamant that I had little interest in doing a design for a WDOC landscape. To me, the beauty of SPP's work is that it offers offenders hands-on opportunity. Since 2004, all SPP's activities that have composed SPP's programs have been in the hands of offenders as much as possible. Typically, work such as endangered species rearing and extensive waste recovery is done by professionals, PhD students, consultants and post-docs.

I inferred that SPP's success has been due in large part to the technical sustainability and scientific expertise that its staff and partners possess. Knowing that I could not create a job for myself as "SPP Design Expert," while still forging my way towards becoming a professional designer, I thought the most efficient way to building capacity for SPP staff and the individuals they work with would be to create a landscape design and construction "toolkit." This concept evolved from a "manual," to a "process model," and is now a "guidebook."

## History of US Prison Landscapes and Affiliated Programs

While SPPs work is indeed revolutionary, the concept of “bringing nature into prisons” has been utilized in a related form by correctional professionals for some time. Before exploring the benefits of modifying prison landscapes and expanding affiliated programs, as well as discussing the actions that have transpired as a result of this thesis project, it is important to understand the context and history of prison landscapes, how they’ve evolved over time, and the philosophical precepts behind their evolution.

As were other cultural institutions of the late 18th and early 19th centuries, early US prisons were influenced by European models of penal practice. From the Middle Ages through the 1600s, European prisons utilized the adaptive reuse of buildings featuring central, flat, expansive atriums or courtyards, defined by interior walls or the arrangement of adjacent buildings within the complex. Monasteries, convents and military forts, often on offshore islands, were commonly converted (Johnston, 28), however, the courtyards were seldom used for rehabilitative, offender betterment, or programmatic purposes.

US prisons borrowed heavily from the “expansive openness within a defined boundary” that defined the repurposed European prisons (Ibid, 67). Prior to the 1800s, US prisons were overwhelmingly urban and resembled what today we recognize as jails. Jails, in contrast to prisons, housed offenders temporarily and approached treatment punitively, with fines, torture and execution being common practices (Cannizzo, 171).

Since the early 19th century, US prisons were intentionally designed by architects. Located in rural contexts, sites were selected for their potential as agrarian landscapes that could be self-sustaining and productive. These landscapes, including former plantations and dairy farms, were repurposed for new correctional facilities (Jiler, 22-25). At the same time, an ideological revolution in regards to offender treatment was gaining momentum. Guided by the concepts of improved health and safety conditions, fixed daily activity routines and general facility design details as means of offender rehabilitation, the modern prison reform movement emerged (Johnston, 43). As the reform movement progressed through the 1800s, previous treatment protocols of fines, torture and execution gave way to methods that utilized the landscape as a means of treatment, including on-site farming and animal husbandry (Jiler, 23).

In the 20th century, horticulture and landscape programs proliferated across the correctional field. Two facilities in New York featured noteworthy examples of sprawling gardens curated by offenders: Sing Sing Correctional Facility in Ossining and the Bedford Facility for Women in Westchester County. At Sing Sing offenders exercised considerable autonomy in modifying the landscape and leveraging external donations to fund various landscape projects, including an aviary. At Bedford, offenders were required to work outdoors maintaining the prison's grounds, as well as take classes in a variety of topics, including carpentry, furniture repair and drafting. Administration stressed "fresh air treatment" as a way of promoting health and as justification for engaging offenders in operational procedures that engaged the landscape, such as producing food for the facility (Jiler, 24-25).

Today, most US prisons have some semblance of a prison horticulture program or landscape maintenance work opportunities (Jiler, 26). In Washington, all 11 prison facilities feature at least one ornamental or productive garden. Two prisons have on-site greenhouses (Sustainability in Prisons Project, "SPP Programs"). Each facility's landscape maintenance crew is primarily composed of offenders, under the direction of a maintenance staff person ("groundskeeper") (Crickmer et al.).

## Prison Landscape Programs: Punitive or Rehabilitative?

The degree to which prison landscape programs are exploitative or beneficial is subject to much debate and quickly crosses into greater philosophical questions surrounding the proper objective of incarceration in our society. Offender-based landscape maintenance crews are often cited as cheap labor benefiting the institution over the individual (Jiler, 26). Conversely, there are many examples of offenders that upon release have found work in landscape, horticultural and related industries as a result of participating in prison landscape programs (Jiler, 147-166; Crickmer et al.; Nadkarni and Pacholke, 28-29).

Criminal justice scholars split the philosophical models of incarceration into two categories: punishment and rehabilitation. The primary objectives of the punishment approach are to restrict the liberties of offenders and segregate them from society. The justification for a punishment approach ranges from a severe “eye for an eye” basis, in which some tangible reciprocity between the offender and the victim is the goal, to one of “justice,” in which maintaining societal welfare via segregation is the goal (Burke, 149, 164-166). The rehabilitation approach aims to change the personalities of offenders so that their criminal inclinations are reduced and that they are better citizens as a result of their incarceration. Corrections and justice professionals attempt offender rehabilitation through three primary means: psychological counseling, partial or alternative institutionalization (such as through house arrest or probation), and programmatic opportunities for offenders to reengage with the community (Bartollas, 9-28).

Within WDOC, there is no clear consensus on the proper role of incarceration. The first three clauses of the law that establish WDOC read:

*(1) The system should ensure the public safety. The system should be designed and managed to provide the maximum feasible safety for the persons and property of the general public, the staff, and the inmates.*

*(2) The system should punish the offender for violating the laws of the state of Washington. This punishment should generally be limited to the denial of liberty of the offender.*

*(3) The system should positively impact offenders by stressing personal responsibility and accountability and by discouraging recidivism. (RCW 72.09.010, Legislative Intent).*

The first two clauses indicate a punitive approach, while the third reflects a rehabilitative approach. In my encounters with WDOC staff, I've observed a general preference towards rehabilitation, but have also heard stories of their colleagues expressing frustration when rehabilitative methods are applied, indicating that a clear preference for a punishment approach does exist at least among some staff within WDOC (Crickmer, et al.).

It can be inferred then that the same is true of both past and contemporary prison landscape programs, there are examples that are punitive and others that offer rehabilitative value. In going forward and expanding prison landscape programs, or "Growing Washington's Prison Landscapes" I believe programs should strive to be rehabilitative to the maximum extent feasible. In thinking of the end goal of rehabilitation as a benefit, the following section addresses specific benefits that arise as a result of modifying the prison landscape.

### A Theoretical Framework for **GROWING WASHINGTON'S PRISON LANDSCAPES**

Adapting the built environment is a challenging endeavor. Because of their unique qualities, modifying or creating landscapes within prison environments is even more challenging. Frequent offender and staff turnover, prioritization of security protocols, and lack of necessary resources such as technical expertise or funding are just three factors that contribute to this reality. Given the unique challenges of working within a prison environment, it is natural to question the “return on investment” (ROI) for any prison landscape design and construction effort. Modifying environments generally requires significant expenditures of energy, capital and time. In contexts like prisons that are often resource limited, being critical of landscape modifications is appropriate and healthy.

Assessing the ROI of prison landscape projects is difficult. Many of the benefits that arise are qualitative and do not lend themselves for easy ROI comparison, as these generally rely on quantitative data and metrics. Additionally, the data that do exist on prison landscape modification do not guarantee that identical results will be carried over from one context or facility to another, even if methods are replicated exactly.

These challenges aside, it is clear there are numerous wide ranging and often non-exclusive benefits that can arise from modifying prison landscapes. This section synthesizes the key theory and evidence for these benefits. The benefits addressed are, in order, a reduction in recidivism, a safer facility, improved operational and ecological functionality, and a culture of agency and empowerment.

### Benefit of Prison Landscape Programming: **REDUCE RECIDIVISM**

Recidivism, or the return to criminal behavior after the successful completion of a previous sentence, is one of the most gripping issues in our national penal system. A recently published study by the US Bureau of Justice Statistics surveyed the post-release activities of over 400,000 offenders, approximately 20% of the current US prison population. Within five years of release, over 75% of those offenders had been re-arrested (DuRose et al., 7). The causes of recidivism are unclear, but both criminal justice scholars and those who have been incarcerated believe that the mere exposure to others who have high propensity for crime, such as through incarceration, may increase criminal behavior in individuals (Chen et al., 1-29; Baca, 361). The US' high rate of recidivism serves as a primary argument against the effectiveness of the prison as rehabilitation model.

Reducing recidivism is a key agency objective for WDOC. The department defines recidivism as any felony offense resulting in a prison conviction within 36 months of a previous offender's release. WDOCs current recidivism rate is approximately 30% (Evans et al., 2).

While there is no single panacea to reduce recidivism, evidence indicates the effectiveness of vocational and educational programming. A 2000 analysis of 25 contemporary vocational education, correctional industry and community employment programs in the *Journal of Offender Rehabilitation* concluded that vocational education programs do work to reduce recidivism (Bouffard et al., 18). Of the programs reviewed in the analysis, the most statistically rigorous and encouraging of the batch indicated a 33% lower risk of re-offense when 8 to 12 years removed from release (Ibid, 16). When comparing the recidivism rate of individuals who participated in vocational and educational programs while incarcerated compared to those who were eligible for such programs but did not participate, the former group exhibited a 5% lower recidivism rate than the latter (Ibid, 15).

A similar meta-analysis of 33 prison education, vocation and work programs saw an 11% reduction in recidivism in program participants compared to controls (individuals who did not participate), and the reduction was greater amongst individuals who participated in education and vocation programs than those who participated only in work programs (Wilson et al., 15).

Of course, vocational education alone is not enough to combat recidivism trends singlehandedly. It is merely a means to an opportunity. Most experts believe that stable employment is the critical factor in ensuring that former prisoners do not reoffend (Redcross et al., ES-1). Unfortunately, ex-prisons face a myriad of challenges in entering the workforce upon release, including low levels of education, little previous work experience and the stigma of incarceration (Ibid). While vocational education programs address the first two challenges, the third challenge is a burden of potential employers. Despite the efforts of social justice advocates, offender rehabilitation professionals, and public policy, many employers are reluctant to hire people with criminal records (Ibid).

Construction is the dominant industry sector that employs ex-offenders. A 2003 analysis of the Los Angeles labor market found the construction industry to be 86% more likely to accept a job application from an ex-offender than the service industry. In terms of actual hires in the same geographic area, construction has exceeded service by 81% (Holzer et al., 38). While little is known about the factors that govern an employer's willingness to consider someone with a criminal record, it is assumed that the data skews towards construction, manufacturing and utility industries because they require comparatively less customer contact (Ibid, 15).

Given the role that vocational education plays in reducing recidivism, combined with the propensity of the construction industry to employ ex-offenders, it seems that landscape based programs are well positioned to contribute to WDOCs goal of reducing recidivism. WDOC currently offers a wide assortment of educational and vocational programming for offenders, and many touch very directly on landscape related tasks, such as horticulture and carpentry (WDOC, "Prison Life – Education"). In general though, most landscape projects completed by these programs are addressed through a limited lens or in a fragmented manner. For example, a horticulture program installs an annual flower garden, but does not complete a set of reference drawings for future program participants, all while a carpentry program constructs a garden shed within the vicinity of the garden.

This is not necessarily a counterproductive outcome, but it does present a missed opportunity for more holistic learning. Growing Washington's Productive Landscapes offers technical guidance in specialized topics related to landscape design and construction in prison environments. It also identifies opportunities and pathways for collaboration between existing and formerly disparate vocational education and work placement programs, giving those program participants exposure to topics and experiences they might not have had otherwise. Because of the multi-disciplinary nature of landscape design and construction, offenders that participate in these programs will be more robust candidates on the job market and theoretically increase their chances of employability, subsequently reducing WDOCs recidivism rate even further.

### Benefit of Prison Landscape Programming: **INCREASE FACILITY SAFETY “NATURALLY”**

Among those who work inside them, prisons are perceived mostly as safe environments (Crickmer et al.; Johnson, 5), a result of the strict order and regiment under which they are operated. To offenders, however, the threat of trauma is real. While the frequency and intensity in which offenders experience trauma is unknown and potentially even uncommon, it does exist across a spectrum, ranging from verbal abuse to physical violence (Rhodes, 13). A commitment to providing a “safe and healthy environment for staff and offenders” is also clearly outlined in WDOC’s Statement of Values (WDOC, “DOC’s Mission Statement”).

While practitioners have long noted that offender contact with nature improves facility safety, unfortunately no quantitative data for that hypothesis exists. The literature speaks in potentials and speculatives, “Caring for living organisms...*can* results in in calmer safer prison settings,” (Kaye et al., 91); “the garden...*may* reduce abusive behavior,” (Lindemuth, “Beyond,” 365); “I *sensed* a dramatic change after months in the greenhouse, (Jiler, 62) (emphasis added by the author). These data are still significant, but require facility managers to look to therapeutic landscape scholarship to understand the conclusions many have drawn about facility safety.

Potentially complicating the association between therapeutic landscape effects and increased prison safety is the fact that the bulk of the scholarship on therapeutic landscapes demonstrates health benefits rather than safety benefits (Winterbottom & Wagenfeld, 12-14, and 31-34). While this may be discouraging at first for prison administrators looking to reduce violence in their facilities, it is important to consider how closely aligned the concepts of health and safety are. They are joined in a variety of everyday contexts, from the federal Occupational Safety and Health Administration (OSHA), to environmental health and safety (EHS) departments in the private sector, to appearing in tandem in WDOC’s Statement of Values mentioned earlier. In applying therapeutic landscape scholarship to improve facility safety, making the connection between safety and health is imperative.

In many ways, stress defines the prison experience for both offenders and staff. The regimented, surveyed monotony, the need to repress emotion and especially the fear of physical violence are three qualities that contribute to the stressful environment of a prison (Rhodes, 122, Conover, 115). Stress and aggression have been strongly correlated by psychologists and sociologists since the 1940s. A recent study of both ex-offender and general population samples found that aggressive behavior increased when individuals were confronted by stressful life events. Additionally, the same study also found that individuals dealing with stressful life situations were more likely to be targeted with aggression by others (Felson, 1-9). Fortunately, stress has been identified as something that can be mitigated by environmental factors (Winterbottom & Wagenfeld, 33).

The correlation between natural settings and positive emotional or mental responses has been understood by psychologists since the mid-20th century. Roger Ulrich is widely credited with leading this line of inquiry within psychology, and his work has proven highly influential in the field of therapeutic landscape design. Ulrich's research demonstrates that exposure to nature, both direct (e.g. time spent in a garden) and indirect (e.g. a view of a garden through a window), results in improved vital signs, and in the case of hospital patients, shorter stays and reduced medication needs (Ibid). Beyond healthcare specific contexts, Ulrich has also demonstrated that an individual's ability to recover from stress is improved by direct and indirect exposure to nature (Lindemuth, "SOU Courtyard," 11). Given the correlation between stress and aggressive behavior, it's reasonable to assume that aggression can be reduced as a result of exposure to natural settings.

In Washington, similar phenomena have been observed in prison environments. An analysis of the Twin Rivers Unit within the Monroe Correctional Complex (MCC) in Monroe, Washington found offenders who had cell views of natural scenery or that participated in outdoor work details to have lower rates of illness complaints compared to controls (West, 82-89). Illness complaints are widely considered as useful measurements of stress, as they document physiological processes correlated with stress including blood pressure fluctuation, nausea, headache, anxiety and musculo-skeletal pain (Ibid, 48-50).

Contact and immersion with nature have also been shown to increase the intrinsic life aspirations of study subjects, particularly as the intensity of exposure increases. The concept of intrinsic life aspiration is defined by psychologists as "the pursuit of goals that in themselves satisfy basic psychological needs (e.g., personal growth, intimacy, community)." (Weinstein et al., 1316). Emotions associated with intrinsic aspirations are love and care, while perspective taking and altruism are affiliated behaviors (Ibid). In high nature-immersion scenarios, intrinsic aspirations are greater than extrinsic aspirations (goals that derive positive regard or reward from others, e.g. money, fame, etc.) by a factor of 7 (Ibid, 1320). As love and care run in direct opposition to concepts of violence and aggression, it can be inferred that natural setting immersion decreases aggression, thus resulting in a safer environment for all.

Beyond the safety benefits derived from the therapeutic elements of landscape, evidence suggests that participation in prison programming alone increases facility safety. In WDOC facilities, participation in programs is contingent on offenders' lacking any behavioral infractions. The desire to participate in programs encourages positive behavior, which contributes to a safer facility. Many offenders also participate in multiple prison programs. WDOC staff believe that as offender time spent in programming increases, opportunities for idleness decreases. Offender idleness is commonly agreed upon as a gateway to risk or danger within a facility (Crickmer et al., Vanneste, 60).

The theory and evidence discussed in this section makes a strong case that both landscape and program elements create a safer prison. Furthermore, it is suggested that safety increases the more these elements are present in the lives of those who live and work in prisons. It is true that existing assorted prison programs (religious, behavior-change, etc.), as well as landscape-based physical elements and programs, already do contribute to a safer prison facility. Because of the intensity and complexity of landscape design/build work, however, we can assume that creating those opportunities will result in even safer facilities than already exist.

### Benefit of Prison Landscape Programming: **ENHANCE OPERATIONAL AND ECOLOGICAL FUNCTION**

Each Washington prison campus houses approximately 1,500 offenders and at least 100+ staff at any given time (WDOC, “Prison - Locations”), all requiring food, water, heat and electricity at regular intervals. In addition, these ~1,600 person prison communities each generate and dispose of wastes created from the previously listed inputs, among others. These essentials of the built environment all carry significant capital costs and have associated and predominantly negative environmental impacts. Furthermore, prisons are perpetual institutions. Unlike many other institutional settings (office, retail, etc.), prisons operate 24 hours a day, 365 days a year; never shutting down and subsequently reducing their utility demands. Given their unique operational requirements and the scales at which they’re designed, the capital and environmental impacts of operating a prison facility are significant.

Increasingly, correctional professionals around the US are evaluating the long-term impacts of the entire corrections “ecosystem” (e.g. buildings, operations, programs, etc.) and are establishing and implementing sustainability plans, both on their own accord and in response to executive order (Vanneste, 46). These plans address a variety of factors including but not limited to resource consumption, goods and services purchased, facility construction & affiliated practices, and maintenance. This movement is broadly known as the “greening of corrections.” (Thigpen et al., i).

WDOC has been a leader in this movement since its inception in the early 2000s. Along with their founding partner The Evergreen State College, the pair has branded their holistic sustainability efforts as the Sustainability in Prisons Project (SPP). Some of SPPs noteworthy operational and environmental accomplishments include a reduction of 100+ million gallons of potable water per year and a 40% reduction in total carbon emissions between 2005 and 2010 (Vanneste, 46). Both metrics are cumulative and apply to the entire portfolio of WDOC facilities.

A similar emphasis on sustainability and green practices has enveloped the design trades as well. The bulk of the discourse and associated standards in green design, however, have focused predominantly on building-level improvements (e.g. energy, materials, indoor environmental quality, etc.), rather than landscape. For example, in the most recent version of Leadership in Energy and Environmental Design (LEED), the most broadly applied green design and construction standard in the world, the amount of available building-specific “credits” doubles those which are specific to landscape (US Green Building Council).

While this trend has become somewhat less drastic and more equitable in recent years with the development of the Sustainable Sites Initiative, the Living Building and Community Challenges, and other programs, clearly huge opportunity exists for landscape to contribute to broader prison sustainability initiatives. Social, cultural and interpersonal beneficial impacts of landscapes aside, when viewed through a purely operational and ecological lens, landscapes have the potential to reuse and recycle waste materials, remediate environmental contamination, regulate discharged stormwater volumes, expand and enhance critical habitat, reduce potable water needs and increase species biodiversity (Rottle and Yocom, 104-125). It should also be noted that this list of examples, while exhaustive, is not complete or definitive. The potential for landscapes to unlock additional unknown efficiencies in prison environments is likely.

Beyond the speculative though, prisons that have already integrated landscape components into their sustainability initiatives have observed positive contributions to their operational and ecological functionality objectives. In regard to operational efficiencies, it appears true that sustainability initiatives applied at the building level result in greater cost savings to a corrections department than similar techniques at the landscape level. California's Department of Corrections and Rehabilitation (CDCR) saved approximately \$3.2 million as a result of energy efficiency initiatives in 2008 alone (Thigpen et al., 4). Yet the landscape still represents great opportunity for fiscal savings.

In Washington, some prisons have begun to see similar cost savings to CDCR's as a result of landscape or landscape-related programs or improvements. For example, Stafford Creek Corrections Center spent \$53,000 to construct an on-site composting operation, the end product being applied to the landscape. Another Washington facility saves \$60,000 annually by diverting its food waste from the landfill. This indicates that a program with a landscape tie can pay for itself in just a year. When potential future savings on site amendments such as compost are considered, the investment can be seen as a revenue generator in the years after implementation (Vanneste, 59-60).

Additional cost savings can be seen when investigating landscape improvements to wastewater infrastructure. Two comparable Washington prison campuses from different design periods (one from the early 1990s, the other from 2009 and built to LEED "Gold" standard) differ in total wastewater costs (disposal, treatment, etc.) by nearly half a million dollars, with the older facility being the more expensive of the two to operate (Ibid, 62). As low impact development (LID) techniques are a component of the current LEED rating system, incorporating rain gardens, cisterns and other LID techniques into prison landscapes can help prisons save money and operate in a more environmentally friendly manor.

While capital and ecological efficiency are clearly very connected, in addition to the landscape-based, cost-saving sustainability efforts described previously, there are also examples that shine brightest in regards to ecological functionality. Between 2009 and 2013, the 4 conservation nurseries across WDOC facilities grew approximately 1 million individual plugs of 63 rare and endangered plant species from the sagebrush steppe and Garry Oak prairie ecosystems of the Columbia Plateau and Puget Lowlands, respectively (Thigpen et al., 91-94).

In many ways, the potential that landscape holds for positively impacting the operational and ecological functionality of a prison is just beginning to be understood. The results are encouraging and exciting. By creating opportunity for even more robust landscape programming within WDOC facilities, be it through offender-led landscape design/build projects as an “intensive” approach, or through additional bodies on landscape maintenance crews as a “conservative” approach, we can assume WDOC will see even more of its operational and ecological functionality objectives realized.

### Benefit of Prison Landscape Programming: **FOSTER AGENCY AND EMPOWERMENT**

While arguably a softer benefit than those previously discussed, landscape based programming can foster agency and empowerment in participating individuals, regardless of their role in the prison ecosystem (e.g. offender, staff, etc.). While WDOC doesn't currently employ any specific mandates to foster agency or empowerment in individuals, the agency's governance does display a strong tendency towards a rehabilitative philosophy, as discussed in the previous section. Furthermore, one of SPPs core goals is to reduce the human impact of prisons. WDOC has encouraged and facilitated the emergence of many SPP programs that, by their own evaluation, are best described as efforts that "elevate the human spirit" (Vanneste, 47). An increased scope of landscape programming in WDOC facilities will only assist in meeting this objective.

To modify the landscape is to exercise some degree of control. The need for individuals to feel a sense of control has been linked to emotional wellness by psychologists for some time and is considered a profound biological need (Winterbottom & Wagenfeld, 11). When an individual's ability to control aspects of their life is compromised, they can experience depression, anxiety and fear (Ibid). As previously discussed, depression, anxiety and fear are all feelings that exacerbate stress, which can compromise the safety of a facility.

The concept of "coherence" addresses the degree to which an individual feels he has control of his life (Ibid). Identity loss, a related concept to coherence, has been strongly noted in incarcerated offenders. Identity loss manifests in incarceration through the loss of personal possessions, the ability to control physical appearance, privacy, and the challenge of maintaining prior relationships (Lindemuth, "SOU Courtyard," 21). It can be inferred then that by providing opportunities for individuals to increase coherence, to exercise control over additional elements in their lives, WDOC will continue its track record of elevating the human spirit.

Design scholarship reveals similar phenomena to coherence, which it frequently characterizes as "empowerment." Empowerment has long been associated with the community design movement, especially when inclusive and participatory methods are utilized (Hester, 24). Small, neighborhood scaled projects serving a single, well defined community are uniquely suited to achieve a sense of empowerment as a result of community design efforts (Melcher, 171-172). Because the interior open spaces in prisons approximate the spaces found within a neighborhood scale, and the classification of "offender," or "custody officer," meets the criteria of a single well defined community, prisons appear to hold great potential for community design projects with empowerment outcomes.

The sense of empowerment gained from participating in landscape projects has been observed in prison. James Jiler, formerly of Rikers Island's notable GreenHouse horticultural program, writes of seeing offenders empowered as a result of time spent in his program multiple times in his 2006 book Doing Time In The Garden (Jiler, 36, 49, 86). A 2014 partnership between FORUM design studio and the Santa Rita Jail in Alameda County, California engaged 20 offenders in both preliminary conceptual design for a reentry campus as well as training to engage in peer-to-peer dialog about the project with neighbors, who had met the project with resistance. This unique approach to pair design services with community outreach had a profound empowering effect on both participants and partnership administrators (Toews & Van Buren).

When design and marginalized populations are correlated, even more evidence of empowerment exists. The Design & Culture Matérielle (DCM) research group at the University of Montreal have explicitly linked design, marginality and empowerment when working with the Atikamekw indigenous peoples of Quebec to generate design innovation(s) amongst native artisans and craftspeople facing both cultural identity loss as well as a loss of traditional physical materials (Marchand & Leitao, 90). Through a series of workshops to conceive alternative products and materials, attempt new design methodologies and develop new price points for the products to achieve new, improved positions in the local traditional craft marketplace, DCM observed an increased sense of empowerment amongst participants (Ibid, 95-99). As offenders are easily and often qualified as a marginalized population (Alexander, 95), the positive findings of the DCM are compelling.

In Building Without Borders, one of the foundational texts that links appropriate building technologies with the development of impoverished communities, Susan Klinker writes:

*“When community members are involved in establishing priorities and in decision making, they are invited to become true stakeholders in a project. Their grassroots involvement helps to expand their resources for future problem solving while allowing them to experience the immediate results of their decisions as the project proceeds. A well-planned community design and planning process can not only improve physical conditions, but can also help to build and raise a community’s sense of responsibility for creating and maintaining a healthy environment. While working together, residents from varying social and ethnic backgrounds often find new understanding of each other and create new common ground for moving forward as supporting neighbors.”* (Klinker, 10-11).

Undoubtedly then, benefits such as an improved sense of responsibility, new understanding of other humans and the establishment of common ground and support can be attained by the expansion of landscape programming in prison environments. As research and testimonials indicate, the more agency and boundary pushing the expansion of such landscape programs are, the more likely participants and facilities will be to experience such benefits.

## Sequencing and Methodology

After spending an academic quarter gaining aptitude in a variety of qualitative research methods, including observation, photo documentation and interviewing, I contacted SPP in the summer of 2014 with the idea of creating a prison landscape design and construction guidebook. Their staff was immediately receptive and circulated the proposal around other key WDOC staff for their endorsement. Many of these individuals eventually became part of the project team. I held an initial visioning meeting with one SPP representative and two WDOC staff. It was agreed that the remainder of 2014 was to be devoted to research and benchmarking to building my familiarity with prisons, prison landscapes, and WDOC.

The project team was assembled by a combination of “open door,” “technical expertise,” and “need to know” philosophy; and was largely recruited and overseen by SPP and WDOC staff. Following my initial contact and upon an initial understanding of the project’s proposed scope, SPP and WDOC took it upon themselves to solicit a diverse representation of necessary parties that could provide both necessary technical knowledge and that had the authority to suggest and develop agency-wide protocols. At the same time, the review team was not restrictive in its composition. As interest in the project arose through inter-agency word of mouth, individuals were welcome to join the project team, which happened with at least one reviewer. I found this team formation approach to be both effective and inclusive. As SPP and WDOC staff had significantly more experience implementing landscape based programs in correctional contexts than I did, I found it best to trust their judgement in ensuring the right people were involved, while simultaneously remaining open to any contributions from other interested parties that WDOC or SPP might have initially overlooked.

I began my research and benchmarking by touring two WDOC facilities (Monroe Correctional Complex in Monroe, WA and Stafford Creek Corrections Center in Aberdeen, WA) to see their landscape and sustainability programs, and meet with staff and offender program participants. These interactions represent the only input from offenders on Growing Washington’s Prison Landscapes to date. As offender betterment and engagement is a major goal of Growing Washington’s Prison Landscapes, I believe it’s likely that an even stronger product would have resulted from having had at least one offender or ex-offender as part of the core project team. While the data gleaned from offender observation and brief interviews during these tours was helpful, it is fair to say it is incomplete and not the entire story of an offender’s likely experience with the program framework Growing Washington’s Prison Landscapes envisions. Unfortunately, given the project’s external nature and roots as a graduate thesis first, rather than a top strategic initiative of WDOC, combined with the inherent logistical and security challenges of involving offenders with community-based projects, the project team could find no efficient way to better involve offenders in the early stages of the conception. The project team is confident, however, that the guidelines and program framework laid out in the guidebook will allow for considerable offender involvement in time after the program is officially launched.

Following my tours, I staged an extensive group interview with key WDOC staff from maintenance, custody, and capital programs to learn about WDOC operations, internal processes, and safety standards. These individuals became a part of the project team and participated in subsequent guidebook reviews. I conducted additional interviews with Professor Julie Stevens and Katherine Cannella, a recent University of Virginia MLA graduate who studied prison gardens around the world, to develop familiarity with prison landscapes beyond WDOC. Having lead prison landscape design/build projects with offenders as a part of her workforce, my discussions with Professor Stevens proved invaluable in developing protocols around material appropriateness and management, tool use and management, and general construction safety considerations. My correspondence with Cannella provided another point of reference for developing design guidelines. As part of her research, she produced measured axonometric drawings of prison gardens, which proved helpful when the review team was unable to determine design guideline specifics (e.g. structure height, number of trees per acre, etc.) from prior methods (observation, interview). Additionally, these drawings occasionally proved helpful in pushing for more robust or progressive design standards than initially assumed and understood.

To deepen my theoretical and technical understanding of the project's content, I conducted an extensive literature review of topical subjects, including design and construction with marginalized populations, criminal justice, prison design, offender rehabilitation, the presentation of design guidelines, and the therapeutic and restorative benefits of nature and landscape. To date, there is very little research that specifically addresses prison landscapes. While the information that does exist proved some of the most relevant and helpful during guidebook drafting process, a cross-disciplinary and broad approach to the content was necessary. With the exception of the therapeutic and restorative benefits of nature, it is safe to say that landscape architecture is largely absent from the subjects I explored. In the explicitly design related subjects, disciplines such as architecture or industrial design were used as a lens to explore prison design or design and construction with marginalized populations, rather than landscape architecture.

Through my literature review and correspondence with project team members and interview subjects, I amassed a significant archive of photos and publications on innovative prison landscape programs in the US and abroad, including as-built CAD drawings of various prison landscapes and operations manuals for related prison programs. These documents proved extremely helpful in developing landscape design guidelines and developing appropriate protocols for both offender involvement and management.

The guidebook was initially drafted between January and June 2015. While the project team was still evolving, and continued until the project's conclusion in December 2015, partial drafts and individual sections were reviewed monthly by at least 8 individuals. The review process operated essentially by consensus. WDOC and SPP project team members strove to meet collectively to synthesize their feedback before presentation to me, however given the size of the project team, and occasional logistical challenges of getting everyone in the same room at the same time, this was not always possible, and individual feedback from project team members had to suffice. In general, feedback from project team members was rarely contradictory or competitive. In the few instances where it was, it was either worked out in the moment via group discussion, or facilitated over time in group email correspondence.

Writing the document and producing the accompanying graphics was anything but a linear process. New information necessitated continual reworking or reorganization of the content. During this time, I presented iterations of the guidebook and project to classmates, UW faculty and landscape architecture professionals through studio pin-ups, mid-term and final reviews. This feedback also proved helpful in shaping the guidebook, but was occasionally challenging when feedback ran contradictory to what the core project team, and in some essence, the "clients," specifically requested in their feedback.

An initial draft was finished in late May 2015. WDOC and SPP project team members reviewed the content over the following month and provided extensive feedback and revisions in a project team meeting in July 2015. At this meeting, a publishing and distribution strategy was determined (2 guidebook copies per facility library, as well as 1 copy per "appropriate" facility program, such as horticulture or carpentry, as not all WDOC facilities have exactly the same program opportunities available).

Between September and December 2015 I completed WDOC and SPPs requested edits, while continuing to refine the document and my corresponding thesis narrative (the "Reflections" section) with my thesis committee. In December 2015, the guidebook was delivered to the SPP and WDOC for full ownership, with publication and distribution scheduled to commence in January 2016.

## REFLECTIONS

---

Given the restrictive and limited nature of a prison, in many ways the project team had to both be creative and work with what was available in amassing information to develop a program that did not previously exist. As such, methods were selected by their availability and feasibility rather than their being a “perfect” tactic for answering a particular research question. With the exception of reduced offender participation, I would characterize the Growing Washington’s Prison Landscape creation process as being particularly successful in its diverse and thorough review process. Inversely, the creation process was challenging because of the broad disciplinary and geographic reach of the project team, particularly when layered atop the reality that the project was attempting to create something for which there was no exact parallel. Ultimately, these challenges, while perhaps generating more questions than answers and thus warranting additional time for investigation, production and review, made for a unique thesis experience and one I feel proud to have played a lead role in.

## Reflection and Aftermath

In some sense, no designer ever knows the future fate of a design or project at its immediate conclusion, whether it will be “successful” or not. In my short design career, never has that reality felt truer than upon conclusion of Growing Washington’s Prison Landscapes. The guidebook does little more than create a mechanism for a horse to be lead to water. Ultimately, it will be up to the offenders and staff within WDOC and SPP to “drink.”

I do not wish to convey that this truth leaves me disheartened. Instead I’m quite encouraged by possibilities of what might arise from someone’s perusal of this resource. The “success” of Growing Washington’s Prison Landscapes to me will not be measured by the number of landscape projects completed at WDOC within X years or the degree to which recidivism is reduced across WDOC over X period of time. Of course, these metrics will be important and will tell part of the project’s success story in time, but for now, Growing Washington’s Prison Landscapes is successful because it provides a framework for our state’s prison community to view their environment as an asset; a way to creatively express, foster personal growth, save the planet, and so much more. Given the intensity of the prison environment and experience, I can think of few scenarios more in need and deserving of this sort of uplift.

I will spend the remainder of this section describing challenges I experienced through the creation of Growing Washington’s Prison Landscapes, reflecting on what I learned, and describe the direction I believe any unresolved challenges or issues are heading in.

From the outset of this project over 18 months ago, I faced critique from some, as well as a small nagging part of myself, that by even participating in the prison industrial complex, no matter how altruistic the intention, my activity was helping perpetuate a brutal and caustic system. This is fair critique, and honestly it’s not one I have a definitive counterargument for. Prior involvement of landscape architects in prisons under some semblance of providing therapeutic or rehabilitative value has been justified by the logic that prisons currently exist, will continue to exist and even grow for the foreseeable future, so the utilization of landscape can potentially benefit the millions of lives of those that live and work in corrections environments (Lindemuth, “SOU Courtyard,” 93). Encouragingly, in the last 5 years, the US has seen its first reduction in the national prison population since the early 1970s, and states across the country are closing and decommissioning prison facilities at a more rapid rate than they are building new facilities (Carroll, 2015). Therefore, it can be argued that the prison industrial complex is slowing, perhaps in no small part because of criminal justice strategies that prioritize rehabilitation over punishment.

This trend doesn't necessarily mean much to those already caught up in or employed by the prison system. To that end, some of the most meaningful insight I've gained as a result of this work was seeing just how many truly bright and caring people are involved in corrections. Prisons are systems too often stereotyped as those that breed nihilism and cynicism. My experience working with WDOC staff and offenders couldn't have been further from that impression. I encountered many individuals from across the agency, all with different backgrounds and expertise, who were highly creative, passionate and caring. Their every action was defined by a drive to improve the lives of their peers, colleagues and cell-mates. It's important to note that this observation holds equal truth for offenders as it does for WDOC staff. The dedication, care and craft I observed in offender crews doing everything from maintaining grounds to operating a recycling facility to leading peer-to-peer sustainability curriculum demonstrated equal ingenuity and compassion to their supervisors. I don't pretend that all prison environments are so nurturing and empathetic, but I have seen that those qualities absolutely do exist, and are often augmented by landscape and sustainability programming components.

Simultaneously, I've grown to more fully embrace the therapeutic and social justice components of Growing Washington's Prison Landscapes, which I was initially somewhat reluctant to do. Because I respect the work of my WDOC colleagues so much, who have other equally important facets of their jobs beyond improving the lives of individuals detained by WDOC (e.g. maintaining a safe environment, operating under tight margins, dealing with staff and offender turnover, etc.), I was sensitive of not coming into the project projecting any notion that offenders needed therapy or rehabilitation, and that a landscape program was the proper mechanism to achieve that goal. I remained open to the possibility that therapeutic value might be the lowest priority of WDOC adopting a new typology of prison landscape program, and that the proposal might be embraced entirely for pragmatic purposes. While I don't think that was ever fully the case, I think my openness to that perspective, ability to listen, and disinclination from framing corrections as a "problem" in need of a "solution" lent my work credibility within WDOC and went a long way to creating a healthy partnership. I can imagine that prison professionals are often inundated by external proposals for offender rehabilitation that are out of touch with necessary operations and protocols, no matter how well intentioned they may be. I did not want to be one of those proposals, and as such, kept the pragmatic components of the project (such as necessary buffer space, tool management protocols, etc.) at the core for much of the work.

However, as I began to revise the guidebook and as I was pushed by my thesis committee and external professional reviewers, I grew more and more comfortable incorporating therapeutic components into the work. It was a challenge to integrate them into a way that was not patronizing and did not diminish the pragmatic components of the guidebook's content. Ultimately, in the guidebook, rehabilitation is present as a theme, but never dominant over any other benefit. This approach allows potential users to achieve a variety of outcomes through the guidebook and customize intended results as much as possible depending on their individual preferences. While I am sensitive to not prioritize one approach over the other, I am now fully comfortable saying that the potential therapeutic and rehabilitative components of Growing Washington's Prison Landscapes are strong, and are on equal plane with the guidebook's other foundational themes, including sustainability, agency, and functionality.

Since program guidebook had been created for WDOC by external stakeholders, let alone completed for an MLA thesis, it was challenging to foresee what content and components the guidebook would require in the early stages of work. Determining these matters required much trial and error, revision and openness. I think the review structure the project team created was adequate, but certainly would have been made more efficient by my being more an "internal" player. Beyond the geographic distance between WDOC facilities, WDOC headquarters and Seattle (making in person meetings challenging), issues of file transfer & access, version control, security clearance, and space & time scheduling were constant hurdles that presumably could have been alleviated by, say, being in the same building as so many of the project team members. While this challenge isn't inherently any different than working on a project with multiple stakeholders or sub-consultants, it did quickly become clear to me that in corrections, such challenges can easily be exacerbated and require even more time and energy than is typical in other professional situations with multiple stakeholders. While I don't believe it was necessary to be a WDOC or SPP employee while working on this project, I am confident that groundwork has been laid so that any individual can pick up the guidebook and begin work on a prison landscape project without encountering the exact same challenges the project team had been through as a result of creating the document.

Additionally, as the content and components of the guidebook took time to solidify, the project was occasionally challenging to articulate to external reviewers in its early stages. The concept is most easily understood by perusal of a complete document, yet because it remained a somewhat nebulous concept for some time as just described, the guidebook's materialization didn't necessarily coincide with the traditional mileposts of the MLA thesis experience. Along these lines, the question of "why I wasn't doing a design" repeatedly came up. This is a fair question, as it is lens in which external design reviewers most naturally see the world, though as previously explained, "designing" a prison landscape was not a goal for mine.

Fortunately, the project's concept was fully grasped upon presentation of a complete guidebook draft in May 2015, but for those who reviewed the project from outside WDOC and the immediate project team, the review process was challenging and occasionally felt arbitrary, as these reviewers were ultimately not the client or the intended audiences, who were actively involved in the document's review. In dealing with this ambiguity, I am grateful to the UW Landscape Architecture faculty and my thesis advisors who remained open to this non-traditional design thesis model and allowed it the time it needed to fully take shape. Through the guidebook's creation I learned the necessity of perseverance, patience and vision when dealing with ambiguous outcomes.

Throughout the process of Growing Washington's Prison Landscapes, there has been discussion of actually and physically "testing" the methodologies outlined in the guidebook by designing and constructing a prison landscape project as per the guidebooks specifications. Ultimately, I think an analysis of such efforts would provide the definitive statement on the guidebook's "success," and would be an ideal conclusion for this thesis. However, given the already extensive amount of time required to complete the guidebook in comparison to the typical timeline available for an MLA thesis, a "test" was not feasible at this time. While this reality is reasonable, I personally hold a strong "if there's a will, there's a way" worldview, and definitely battled some personal frustration at having not tested the guidebook's framework, feeling my personal will to do so was not strong enough.

While this frustration will likely always be present, I am encouraged by the project's future potential and what it may catalyze. WDOC and SPP have been extremely pleased by the results of the document and are excited to utilize the guidebook in future diverse programming efforts. Through SPP, the work has been introduced to other criminal justice and design professionals who have both provided comment and inquired about the possibility of modifying the document for use in other jurisdictions or contexts, as well as broadly publishing it in academic journals or otherwise. This has been a particular interest from one of the project's advisor, who has strong ties to Pennsylvania's Department of Corrections, as well as the leading publications on criminal and restorative justice theory and practice. Finally, this project has linked WDOC and UW's Landscape Architecture Design/Build Studio, who are currently in discussion of collaborating on a project at Washington Corrections Center for Women in Gig Harbor, Washington in the immediate future, which has been a longtime goal of the studio's instructor.

I hope to remain involved in landscape based programming and efforts in Washington prisons beyond graduation as my time allows and as my support is needed by interested parties, but at this point am not exactly sure what route that support might take or how it may look. I am confident, however, that Growing Washington's Prison Landscapes will serve as a resource to both parties in their future work, as well as any other individuals that want to help change a prison landscape, no matter their identity or role.



## WORKS CITED

Baca, Jimmy. Past Present. In Working In The Dark: Reflections of a Poet of the Barrio. Santa Fe, NM: Red Crane Books, 1992.

Bartollas, Clemens. Correctional Treatment: Theory and Practice. Upper Saddle River, NJ: Prentice-Hall, Inc., 1985.

Bouffard Jeffrey; Doris MacKenzie and Laura J. Hickman. "Effectiveness of Vocational Education and Employment Programs for Adult Offenders: A Methodology-Based Analysis of the Literature." *Journal of Offender Rehabilitation*. 31: 1-2: (2000). 1-41.

Burke, Roger H. Criminal Justice Theory: An Introduction. London: Routledge, 2012.

Cannella, Katherine. What is a Prison Garden? Benjamin C. Howland Fellowship Exhibit, Campbell Hall East Gallery, University of Virginia, Charlottesville, VA. 2015.

Cannizzo, John. Growing with the Garden: A Curriculum for Practicing Horticulture with Incarcerated Individuals. The Horticultural Society of New York. 2010.

Carroll, Lauren. "Federal prison population drops for first time in 3 decades, Eric Holder says." PolitiFact, February 23, 2015.

Available online at

<http://www.politifact.com/truth-o-meter/statements/2015/feb/23/eric-holder/federal-prison-population-drops-first-time-3-decad/>.

Chen, M.K. and J.M. Shapiro. "Do Harsher Prison Conditions Reduce Recidivism? A Discontinuity-Based Approach," *American Law and Economics Review*. 9: 1: (2007). 1-29.

Conover, Ted. New Jack: Guarding Sing Sing. New York: Vintage Books. 2001.

Crickmer, Anna (Project Manager, WDOC Capital Programs), Troy Hansen (Maintenance Mechanic, WDOC) and Sgt. Sarah Lamm (Custody, WDOC). Interview by the author. Transcribed recording. Monroe, WA. November 6, 2014.

DuRose, Matthew R., Alexia D. Cooper, and Howard N. Snyder, Recidivism of Prisoners Released in 30 States in 2005: Patterns from 2005 to 2010. Bureau of Justice Statistics Special Report, April 2014, NCJ 244205.

Evans, Michael, Terri Herold-Prayer, Susan Owley-Koenig, Emily Yette, Ilyne Lawson and Sharon Semegen. Recidivism Revisited. Washington Department of Corrections. August 2010.

Available online at <http://www.doc.wa.gov/aboutdoc/measuresstatistics/docs/Recidivism%20Revisited.pdf>

Felson, Richard. "Kick 'Em When They're Down: Explanations of the Relationship between Stress and Interpersonal Aggression and Violence." *The Sociological Quarterly*. 33: 1: (1992). 1-16.

Hester, Randolph. Community Design Primer. Mendocino, CA: Ridge Times Press, 1990.

Holzer, Harry, Steven Raphael and Michael Stoll. "Employer Demand For Ex-Offenders: Recent Evidence from Los Angeles." Urban Institute. March 2003. Available online at <http://www.urban.org/research/publication/employer-demand-ex-offenders>.

Jiler, James. Doing Time in the Garden: Life Lessons Through Prison Horticulture. New York: New Village Press, 2006.

Johnson, Robert. Hard Time: Understanding and Reforming the Prison. Monterey, CA: Brooks/Cole, 1987.

Johnston, Norman. Forms of Constraint: A History of Prison Architecture. Chicago: University of Illinois Press, 2000.

Jost, Daniel. 'A Garden Behind Bars.' *Landscape Architecture Magazine*. 103: 11: (2013).

Available online at <http://landscapearchitecturemagazine.org/2013/11/04/a-garden-behind-bars/>

Kaye, Thomas, Kelli Bush, Chad Nagule and Carri LeRoy. "Conservation Projects in Prison: The Case for Engaging Incarcerated Populations in Conservation and Science." *Natural Areas Journal*. 35: 1: (2015). 90-97.

Klinker, Susan. "Shelter and Sustainable Development." In Building Without Borders: Sustainable Construction For The Global Village, edited by Joseph Kennedy, 5-33. Gabriola Island, BC: New Society Publishers, 2004.

Lindemuth, Amy “Beyond the Bars: Landscapes for Health and Healing in Corrections.” In Greening in the Red Zone: Disaster, Resilience and Community Greening, edited by Keith Tidball and Marianne Krasny, 361-374. Berlin: Springer, 2014.

Lindemuth, Amy. “SOU Courtyard Garden: Designing a Therapeutic Environment for Corrections Staff and Mentally Ill Offenders.” MLA Thesis, University of Washington, 2006.

Marchand, Anne and Renata Marques Leitao. “Design as a Means of Empowerment in Native Communities: Innovative Atikamekw Products Dedicated to a Global Marketplace.” *The International Journal of Design in Society*. 7: 2: (2014). 87-101.

Melcher, Katherine. “Equity, Empowerment or Participation: Prioritizing Goals in Community Design.” *Landscape Journal*. 32: 2: (2013). 167-182.

Nadkarni, Nalini and Dan Pacholke “Bringing Sustainability and Science to the Incarcerated: The Sustainability in Prisons Project.” In The Sustainability in Prisons Project: An Overview (2004-2012), edited by Carri LeRoy, Kelli Bush, Joslyn Trivett and Brittany Gallagher, 25-39. Olympia, WA: Gorham Publishing, 2012.

Redcross, Cindy, Dan Bloom, Gilda Azurdia, Janine Zewig and Nancy Pindus. Transitional Jobs for Ex-Prisoners: Implementation, Two-Year Impacts, and Costs of the Center for Employment Opportunities Prisoner Reentry Program. New York: MDRC, 2009.

Rhodes, Lorna. Total Confinement: Madness and Reason in the Maximum Security Prison. Berkeley: University of California Press. 2004.

Rottle, Nancy and Ken Yocom. Basics Landscape Architecture 02: Ecological Design. Switzerland: AVA Publishing SA, 2010.

Stevens, Julie (Assistant Professor, Landscape Architecture, Iowa State University). Interview by the author. February 27, 2015.

Sustainability in Prisons Project. “History.”  
<http://sustainabilityinprisons.org/about/spps-history/>

Sustainability in Prisons Project. "SPP Programs in Washington State Prisons."

<http://sustainabilityinprisons.org/what-we-do/spp-programs-in-washington-state-prisons/>

Thigpen, Morris; Thomas Beauclair and Shelly Carroll. The Greening of Corrections: Creating a Sustainable System. Washington, DC: US Department of Justice. 2011.

Toews, Barb and Deanna Van Buren. "Designing For Restorative Re-entry."

<http://us7.campaign-archive2.com/?u=1adf440ae2ceb34fbd6b51296&id=283683b634&e=2b478414c2>.

Published February 9, 2015.

US Green Building Council. "LEED v4 for Building Design and Construction: New Construction & Major Renovation."

<http://www.usgbc.org/resources/leed-v4-building-design-and-construction-checklist>

Vanneste, Julie "Sustainable Operations at Washington State Department of Corrections." In The Sustainability In Prisons Project: An Overview (2004-2012), edited by Carri LeRoy, Kelli Bush, Joslyn Trivett and Brittany Gallagher, 45-62. Olympia, WA: Gorham Publishing, 2012.

Washington Department of Corrections. "DOC's Mission Statement." <http://www.doc.wa.gov/aboutdoc/mission.asp>

Weinstein, Netta; Andrew Przybylski and Richard Ryan. "Can Nature Make Us More Caring? Effects of Immersion in Nature on Intrinsic Aspiration and Generosity." *Personality and Social Psychology Bulletin*. 35: (2009). 1315-1329.

West, Marcia. "Landscape Views and Stress Response in the Prison Environment." MLA Thesis, University of Washington, 1985.

Wilson, David; Catherine Gallagher and Doris MacKenzie. "A Meta-Analysis of Corrections-Based Education, Vocation, and Work Programs for Adult Offenders." *Journal of Research in Crime and Delinquency*. 37: 4: (2000). 347-368.

Winterbottom, Daniel & Amy Wagenfeld. Therapeutic Gardens: Design for Healing Spaces. Portland, OR: Timber Press, 2015.