

HOUSING METANOIA:
ACCOMMODATING THE MODERN FAMILY'S
CHANGING SPATIAL NEEDS THROUGH FLEXIBLE DESIGN

JOHN BRADFORD UNTEREKER

A THESIS
SUBMITTED IN PARTIAL FULFILLMENT OF THE REQUIREMENTS FOR THE DEGREE OF
MASTER OF ARCHITECTURE.

UNIVERSITY OF WASHINGTON
2016

COMMITTEE:
BRIAN McLARAN
GUNDULA PROKSCH

PROGRAM AUTHORIZED TO OFFER DEGREE:
ARCHITECTURE

© COPYRIGHT 2016
JOHN BRADFORD UNTEREKER

UNIVERSITY OF WASHINGTON

ABSTRACT

HOUSING METANOIA:
ACCOMMODATING THE MODERN FAMILY'S
CHANGING SPATIAL NEEDS THROUGH FLEXIBLE DESIGN

JOHN BRADFORD UNTEREKER

CHAIR OF THE SUPERVISORY COMMITTEE:
ASSOCIATE PROFESSOR BRIAN MCLARAN, CHAIR
ASSOCIATE PROFESSOR GUNDULA PROKSCH
DEPARTMENT OF ARCHITECTURE

The goal of this investigation is to understand how architecture can respond to the existing housing stock to accommodate a more family/community-centered living opportunity through flexible spaces. The design will allow residents to incrementally expand or contract their living spaces through a modular approach thus: bring families back into urban neighborhoods through thoughtful multigenerational housing design, create a community of diverse ages, encourage a sustainable lifestyle, and address affordability in desirable urban neighborhoods.

THIS PAGE IS LEFT INTENTIONALLY BLANK

H O U S I N G M E T A N O I A :

**ACCOMMODATING THE
MODERN FAMILY'S
CHANGING SPATIAL
NEEDS THROUGH
FLEXIBLE DESIGN**

Master of Architecture Thesis
by John Bradford Untereker



SPECIAL THANKS TO:

BRIAN McLARAN,
RICK MOHLER,
GUNDULA PROKSCH

MY FAMILY,
FRIENDS,
AND CATS

TABLE OF CONTENTS:

PART 1: INVESTIGATION	1	PART 2: RESPONSE	31
CHAPTER 1: Problem	2	CHAPTER 4: Site Selection	32
1.1 Obstruction of Evolution	3	4.1 Seattle	33
1.2 Foundations	4	4.2 Example Neighborhood: Wallingford	37
1.3 Catalysts – Reasons for the Shift	7	4.3 Specific vs Generic Sites	39
1.4 Obstructions Expounded	9	4.4 Users	41
1.5 Benefits of Multi-Generational Living	10	4.5 Program	41
1.5.1 For the Residents	10		
1.5.2 For the Built Environment	11	CHAPTER 5: Design	44
1.7 Thesis Statement	13	5.1 Design Considerations	45
CHAPTER 2: Theoretical Framework	14	5.2 Design Logic	47
2.1 Family Needs	15	5.3 Module Types	48
2.2 Existing Multi-Generational Typologies	17	5.4 Constructibility	53
2.3 Expanding on the Existing Models	19	5.5 Accessibility + Website Design	59
2.4 Spatial Flexibility + Incremental Development	20	5.6 Expansion and Contraction	63
2.5 Take-Away from Theoretical Framework	21	5.7 Community Elements	65
CHAPTER 3: Case Studies	22	CHAPTER 6: Final Thoughts	68
3.1 Tatiana Bilbao’s Sustainable House	23		
3.2 ELEMENTAL’s Villa Verde Housing	25	LIST OF FIGURES	72
3.3 Traditional Japanese Houses	26		
3.4 Take-Away	29	WORKS CITED	74

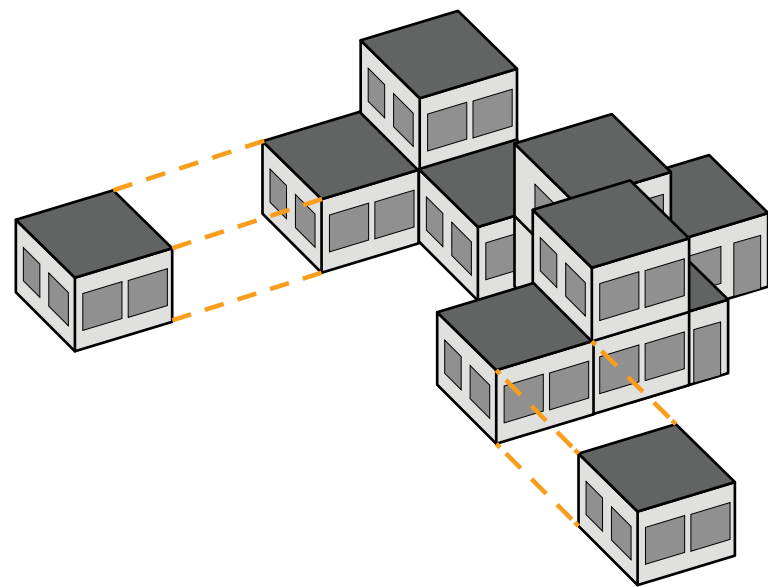

METANOIA: *ΜΕΤΑ'ΝΟΙΑ*

CHANGE IN A WAY OF LIVING OR THINKING

FROM GREEK: META (μετά-), AFTER

NOEIN (νοεῖν), TO PERCEIVE

HOUSING METANOIA IS A NEW DEVELOPMENT IN THE SINGLE FAMILY HOUSING TYPOLOGY, THAT ACCOMMODATES THE MODERN FAMILY'S CHANGING SPATIAL NEEDS THROUGH FLEXIBLE DESIGN.

THIS PAGE IS LEFT INTENTIONALLY BLANK

PART 1: INVESTIGATION



CHAPTER 1: The Problem



1.1 Obstruction of Evolution

An evolution is currently happening in American families, both physically and psychologically. This evolution has the opportunity to greatly improve lives and lifestyles, as well as change how people view the built environment. The American family is readily discarding its nuclear nature and is becoming increasingly multi-generational.¹

There exists an obstruction to this evolution. Existing housing and the current housing model are designed to be spatially rigid and reflect a specific stage of life or lifestyle. The current model does not reflect the numerous lifestyle changes in the occupants' lives, and for the case of this thesis the needs of multi-generational

¹ According to a 2010 Pew Research Center report cited below [2], a multi-generational household consists of: "Two generations, or parents (or in-laws) and adult children ages 25 and older (or children-in-law);" "Three generations, or parents (or in-laws), adult children (and spouse or children-in-law), grandchildren;" A "'skipped' generation, or grandparents and grandchildren, without parents (including step-generation);" And more than three generations co-residing..

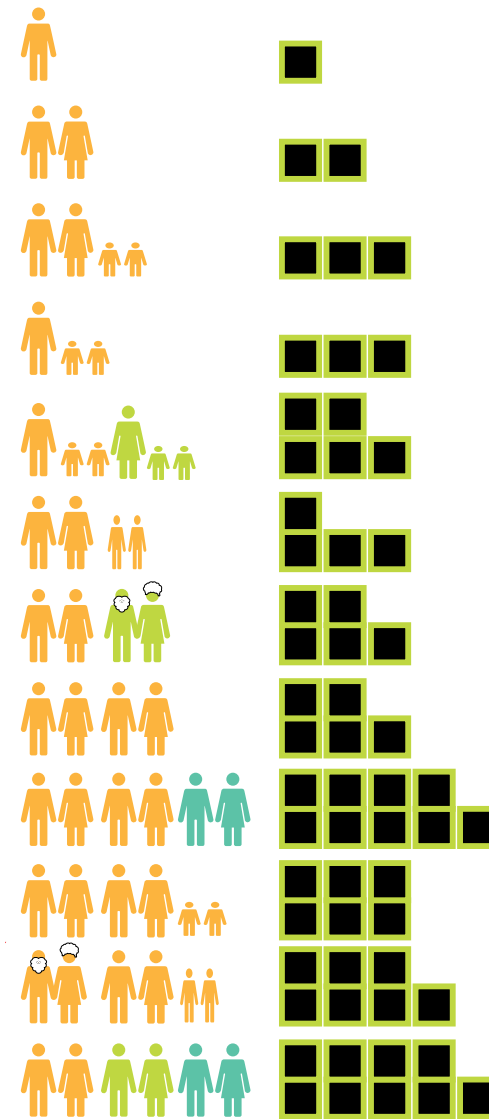

FIGURE 1.1: CHANGING SPATIAL REQUIREMENTS
A family's spatial requirements change with them.

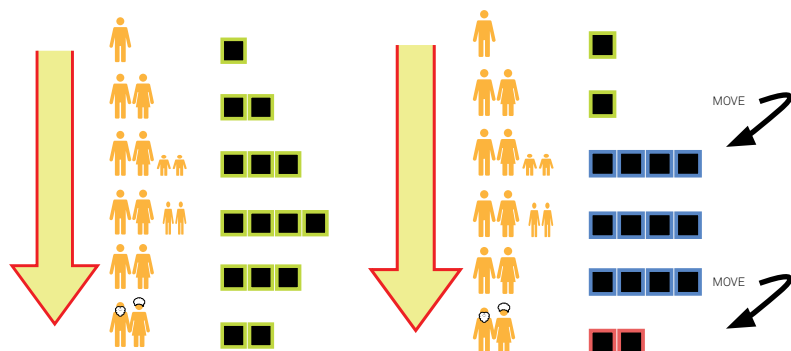

FIGURE 1.2: SPATIAL REQUIREMENTS: IDEAL VS ACTUAL
Current housing does not align with people's changing spatial requirements.

occupants. Therefore, as the spatial needs of the occupants change, they are forced to either live in spatially inadequate conditions or find new housing that suits their needs. As family size and demographics fluctuate with different stages of life, housing should be able to change in tandem.

1.2 Foundations

Multi-generational living is not a new phenomenon. It was the dominant form of living arrangement for the majority of human history. Not until the 1930s and 1940s did American families start to seek separate living arrangements. According to a 2010 study done by the Pew Research Center, the number of multi-generational living arrangements for people older than 65 decreased from 57 to 17 percent between 1900 and 1980. Also, in 1940 roughly a quarter of the total population lived in multi-generational households, but by 1980 this number was cut in half.² Currently, however, the trend is reversing, in part fomented by the financial crisis of 2008.

The recession of 2008 had a greater effect on two major demographics: the Millennial generation and

² Paul Taylor, Jeffrey Passel, Richard Fry, Richard Morin, Wendy Wang, Gabriel Velasco, and Daniel Dockterman, "The Return of the Multi-Generational Family Household," Pew Research Center, March 18, 2010, accessed April 22, 2016, <http://www.pewsocialtrends.org/files/2010/10/752-multi-generational-families.pdf>.

the Baby Boomer generation.³ Together, they make up roughly half of the total population of the United States, and are major contributors to the growing trend of multi-generational living.

According to a later Pew Research Center study, “a record 57 million Americans, or 18.1% of the population of the United States, lived in multi-generational family households in 2012, double the number who lived in such households in 1980.”⁴ More adults under the age of 35 are living with their parents than any other time in the past

³ The Millennial generation, henceforth known as Millennials, are individuals born between 1981 and 1997, or are adults aged 18 to 35. As the largest demographic group in the country, they represent just over 25 percent of the total population. In total, they number 81.3 million. The baby boomer generation, henceforth known as Baby Boomers, are individuals born between 1946 and 1964, or are adults aged 52 to 70. Once the largest demographic group in the country, they represent just under 25 percent of the total population. In total, they number 75.4 million.

⁴ Richard Fry and Jeffrey S Passel, “In Post-Recession Era, Young Adults Drive Continuing Rise in Multi-Generational Living” Pew Research Center, July 17, 2014, accessed April 22, 2016, <http://www.pewsocialtrends.org/2014/07/17/in-post-recession-era-young-adults-drive-continuing-rise-in-multi-generational-living/>.

Population Living in Multi-generational Households Has Doubled Since 1980

In millions

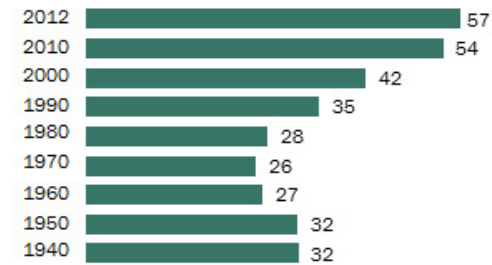

Share Living in Multi-generational Households Continues To Rise

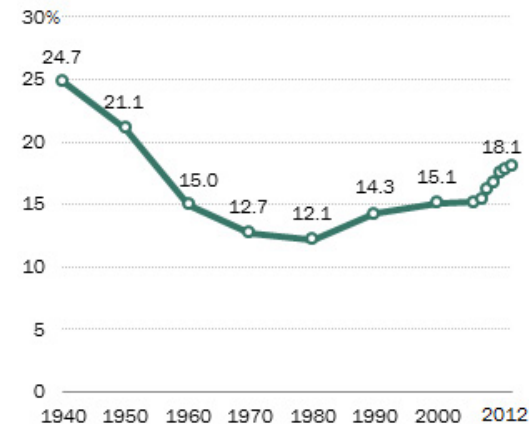

Source: Pew Research Center analysis of U.S. Decennial Census data, 1940-2000, and 2006-12 revised weight American Community Surveys (IPUMS)

PEW RESEARCH CENTER

FIGURE 1.3: MULTI-GENERATIONAL STATISTICS

Showing the sharp increase in multigenerational households in the past decade. Source: Pew Research Center, see footnote 4.

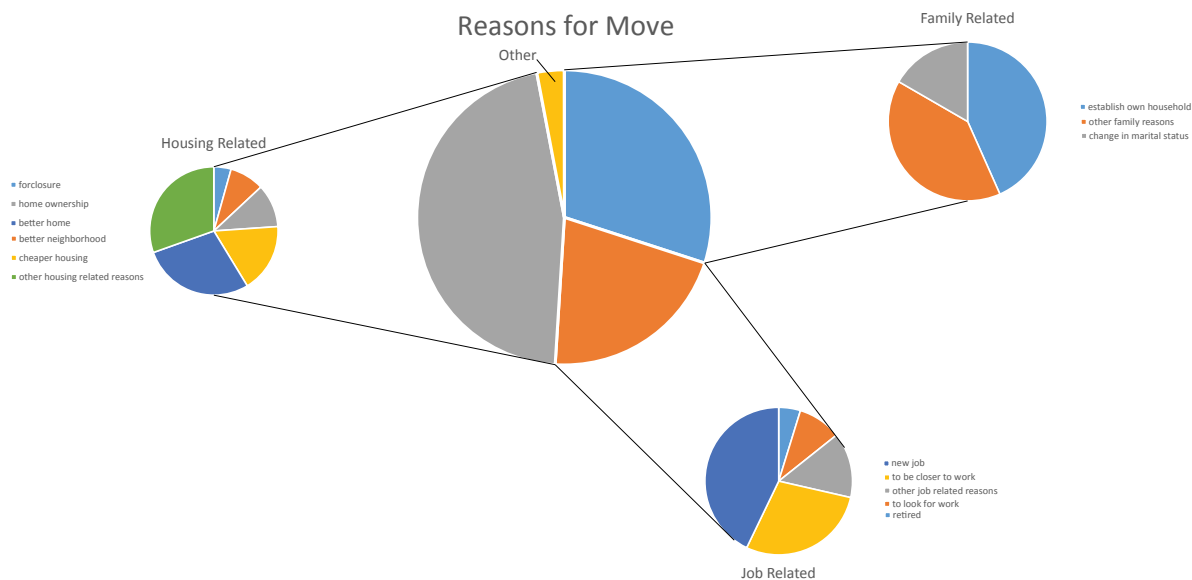

FIGURE 1.4: REASONS FOR MOVING

The majority of moves could be avoided with spatial flexibility integrated into the housing.

Source: United States Census Bureau, census.gov.

three decades.⁵ Between 1999 and 2013, the incidence of 30-year-old adults residing with their parents increased from 18.7 to 31.5 percent. Likewise, the incidence of 25-year-olds residing with their parents increased from 28.3 to 48.8 percent. Despite positive economic momentum in the past few years, this trend has continued to increase.

⁵ Quentin Fottrell, "The Case for Living with Mom and Dad," Market Watch, May 7, 2013, accessed April 10, 2016, <http://www.marketwatch.com/story/the-case-for-living-with-mom-and-dad-2012-08-31>.

Living with a parent is the most common young adult living arrangement for the first time on record

% of 18- to 34-year-olds by living arrangement

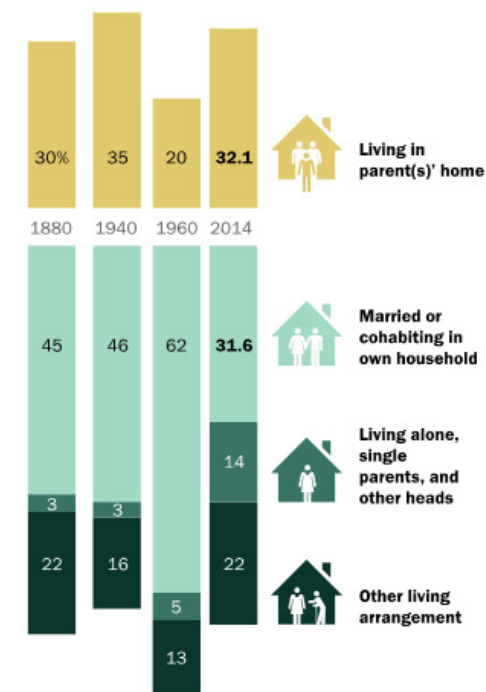

Note: "Living in parent(s)' home" means residing in a household headed by a parent regardless of the young adult's partnership status. "Other heads" include young adults who are the household head and living with roommates or boarders. "Other living arrangements" include living in the home of a grandparent, an aunt/uncle or a sibling or residing in a group quarters living arrangement (college dormitory or correctional facility).

Source: Pew Research Center tabulations of the 1880, 1940 and 1960 U.S. decennial censuses and 2014 American Community Survey (IPUMS)

PEW RESEARCH CENTER

FIGURE 1.5: MULTI-GENERATIONAL STATISTICS

Young adults are increasingly choosing to live with their parents.

Source: Pew Research Center, see footnote 4.

1.3 Catalysts – Reasons for the Shift

As the evolution toward multi-generational living continues to gain momentum, the reasons for this evolution need to be explained. The reasons for the shift to multi-generational living are manifold; however, the most pressing are to ease the rising costs of living, build stronger communities, and provide child and elder care.

The recession of 2008 and the subsequent unemployment forced many Millennials to either never move out of or move back into their parental homes. The economic downturn coupled with marrying and starting their own families later in life has resulted in this demographic living with their parents longer. At the beginning of their careers, Millennials are making less money than their parents did. Adjusted for inflation, they make 13.4 percent less based on median weekly earnings

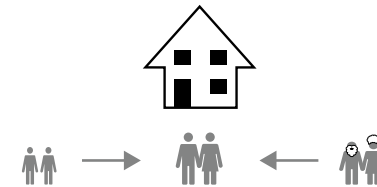

FIGURE 1.6: MOVING BACK HOME
Young adults and seniors are moving back home.

from 1979 and 2013.⁶ A lower income coupled with massive college debt (42% of this population has college debt)⁷ also account for the increase in multi-generational living among this population.

Baby Boomers are starting to retire, and are looking to downsize their current living circumstances. While some choose to move to retirement communities, a considerable

⁶ Andy Kiersz, "Millennials Aren't Making As Much As Their Parents Did When They Were Young," Business Insider, December 5, 2014, accessed April 10, 2016, <http://www.businessinsider.com/young-adult-vs-all-adult-weekly-earnings-2014-12>.

⁷ "Student Debt Viewed as Major Problem; Financial Considerations Important Factor for Most Millennials When Considering Whether to Pursue College" Harvard Institute of Politics, <http://iop.harvard.edu/student-debt-viewed-major-problem-financial-considerations-important-factor-most-millennials-when>.

number choose to move in with their adult children. Fewer Baby Boomers today consider retirement communities or nursing homes desirable. They would prefer to age-in-place and/or move in with other family members. This is made increasingly more possible because they are living longer and are in better health. In previous years, older adults were forced out of independent living due to health conditions and other issues, but now they have the option to stay put.

Increased immigration and cultural diversity is another important factor in the increased interest in multi-generational living. Cultures where multi-generational living is the standard, such as Hispanic and Asian, have immigrated in large numbers over the past few decades, bringing with them the custom of multi-generational living. In many immigrant cultures, including Hispanic and Asian, it is expected for children to take care of their parents during old age; as families grow, they anticipate this shift.

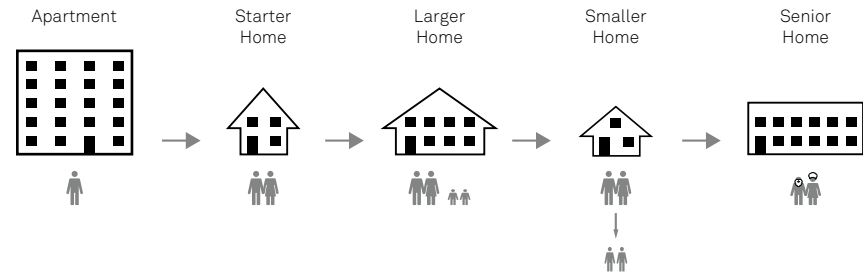

FIGURE 1.7: EXISTING HOUSING MODEL
Lack of flexibility in current model causes people to move to better accommodate their spatial needs.

Thus, for these reasons, more families are turning to a multi-generational housing typology, which is a growing trend throughout the country. As such, the traditional housing paradigm of Post-War America is shifting.⁸ Unfortunately, the current stock of housing is ill-equipped to accommodate this shift.

⁸ This paradigm is: A young family buys a house, has a couple of kids, move to a bigger house when the kids get older, the kids go off to college, the parents downsize with retirement, and then possibly move into a retirement facility/community. Meanwhile, after college, their kids start their own family and start the cycle all over again.

1.4 Obstructions Expounded

The current housing model is insufficient. Throughout the country, most family-sized housing exists in the form of detached single-family residences.⁹ However, as the city continues to grow, this housing stock is being demolished in favor of multi-family apartment developments. More often than not, the units in such developments are small in size and do not accommodate families. These developments contain few family-sized units. Due to the lack of family sized and affordable housing, middle-income families are moving away from desirable urban neighborhoods.

There are a number of zoning code obstacles to developing more multi-generational housing options. Zoning codes determine the density allowed as well as

⁹ Family-sized units are units that have 3 or more bedrooms.

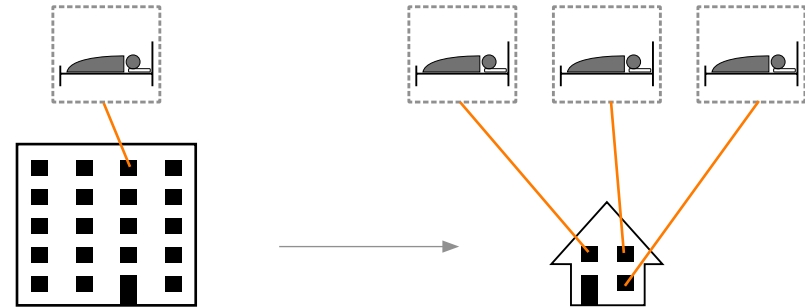

FIGURE 1.8: FAMILY SIZED UNITS
Multifamily apartments usually only have 0-2 bedroom units, whereas family sized units have 3 or more bedrooms.

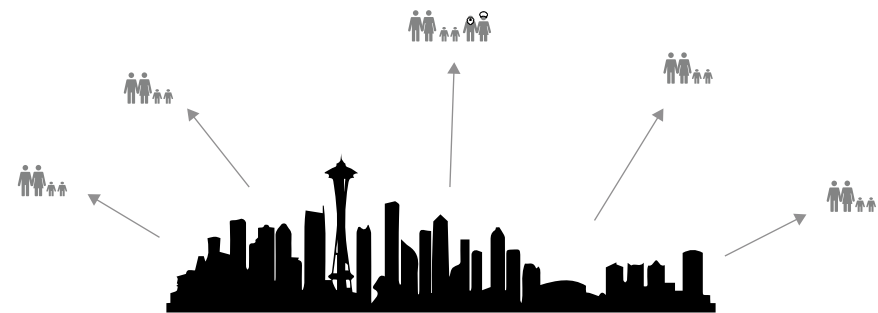

FIGURE 1.9: FAMILY SIZED UNITS
Families moving out of the city to find larger units.

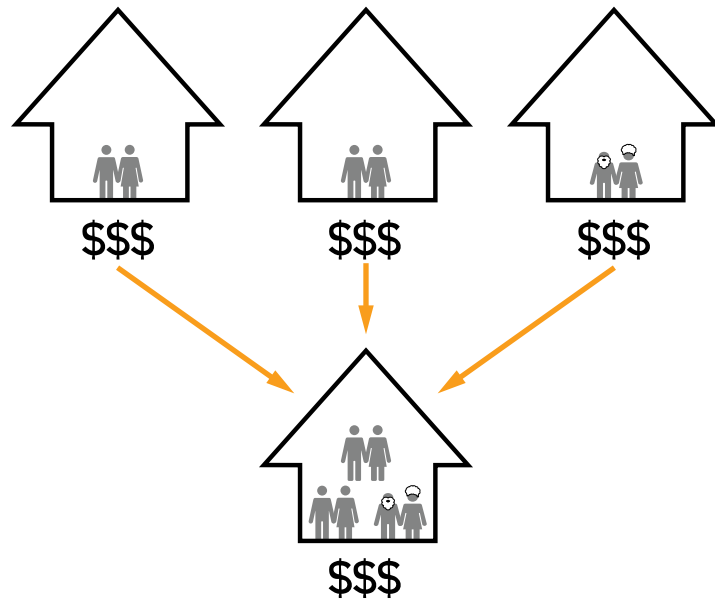

FIGURE 1.10: IMPLICIT COST SAVINGS
 Cost reductions occur by combining resources.

specify what can be built in a certain neighborhood. Some codes can even exclude certain types of units from being built. Planners and policy makers control the majority of this realm, and thus further discussion of the impact of zoning codes are not within the topic of this thesis.

1.5 Benefits of Multi-Generational Living

1.5.1 For the Residents

The greatest benefits of multi-generational living for the residents are cheaper cost of living, stronger communities, and easily available child and elder care. Multi-generational living is becoming more necessary. As the cost of living increases, having a close family structure becomes more desirable. Live-in grandparents to care for children in dual income households is both financially and socially beneficial. Easing this burden is essential for the retention of the urban middle-class family, as the average cost of daycare in a majority of States in the country is higher than the average cost of in-state undergraduate college education.¹⁰ Likewise, elder care – independent or assisted living facilities are historically expensive. Multi-

¹⁰ Eric Morath, "States Where Day Care Costs More Than College," The Wall Street Journal, April 11, 2016, accessed April 25, 2016, blogs.wsj.com/economics/2016/04/11/states-where-day-care-costs-more-than-college/?mod=e2fb.

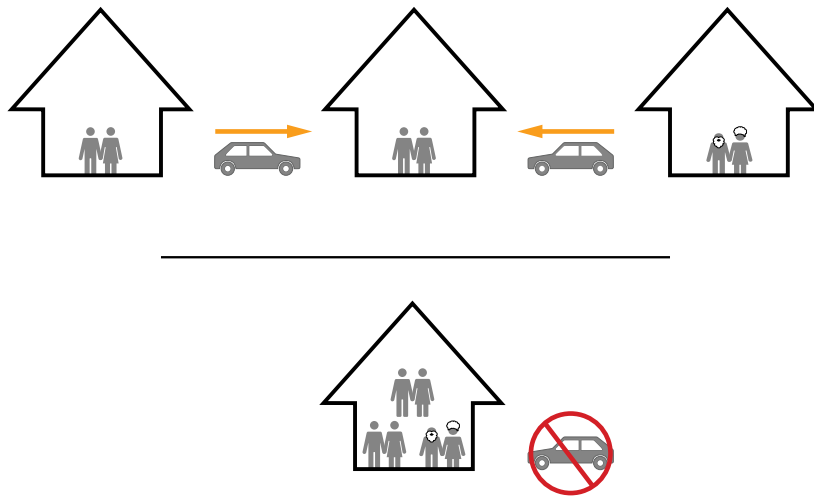

FIGURE 1.11: IMPLICIT ENVIRONMENTAL BENEFIT
Reduces automobile dependency and requires fewer natural resources.

generational housing can cover the amenities that those facilities include. In addition, other costs of living can be reduced.

Though multi-generational living is not a solution for all households, those who choose to live in multi-generational homes typically have strong family cohesion and better family relationships.

1.5.2 For the Built Environment

Just as families are embracing this shift to multi-generational housing, architects, planners, and developers need to follow suit. There are numerous benefits of multi-generational living to the built environment.

Density increases with each generation that lives under the same roof. This seems pretty self-explanatory, but it is an important aspect to recognize. The importance of an increased density is well known to the built-environment community, but worth reiterating. Higher residential density should strike a balance between privacy and interaction within a community, provide increased safety, reduce cost of living, and allow for greater opportunity for sustainable design features.

It addresses sustainability. With most of the family in one location, multi-generational living reduces the environmental cost of transit for family gatherings.

Also, the footprint of multiple generations living in one residence has less of an impact than if they were to be living in two or more discrete houses on two or more discrete plots of land.

Having a mix of generations is beneficial to the development of a community. The elderly have plenty to offer not only their families, but the community at large. Increasing the elderly population in neighborhoods also helps put additional “eyes on the street,” as Jane Jacobs would say. Jacobs also argues that the elderly have the time and patience to watch the neighborhood, therefore making this population a key ingredient to a healthy neighborhood. However, the elderly have been relegated to retirement communities and nursing homes, away from the younger generations. Reversing this trend of cloistering the elderly is necessary, as “old people cannot

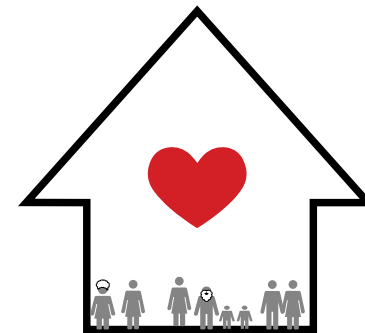

FIGURE 1.12: IMPLICIT SOCIAL BENEFIT
Better family relationships and better neighborhoods.

be integrated socially as in traditional cultures unless they are first integrated physically.”¹¹

¹¹ Christopher Alexander, *A Pattern Language: Towns, Buildings, Construction* (New York: Oxford University Press, 1977), 215-220.

1.7 Thesis Statement

As family needs change and develop, their housing and spatial requirements also change. However, the existing housing stock and building methods are insufficient to accommodate these changes in environmentally, socially, and economically sustainable ways. Renovating existing housing, or moving are the only options currently available. This conventional way of adapting a home to new life phases can be difficult, costly, and time consuming. This thesis proposes to address a modern family's needs to adapt to changing ways of living through modular, flexible housing.

The goal of this investigation is to understand how architecture can respond to the existing housing stock to accommodate a more family/ community-centered living opportunity through flexible spaces. The design will allow

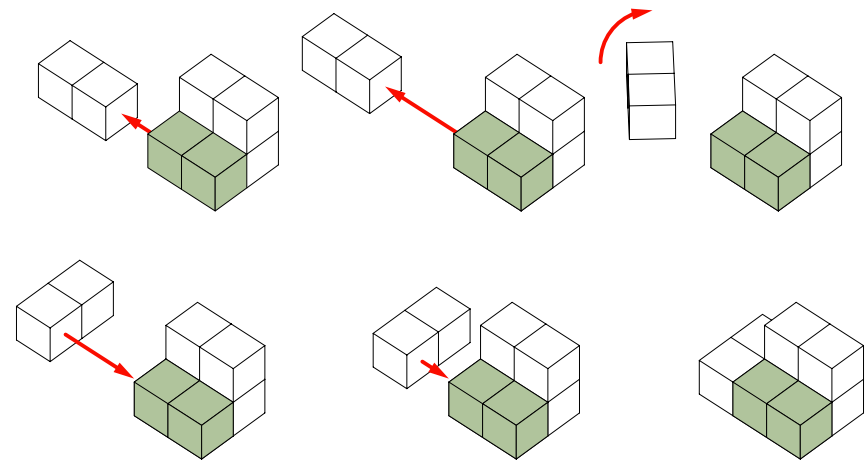
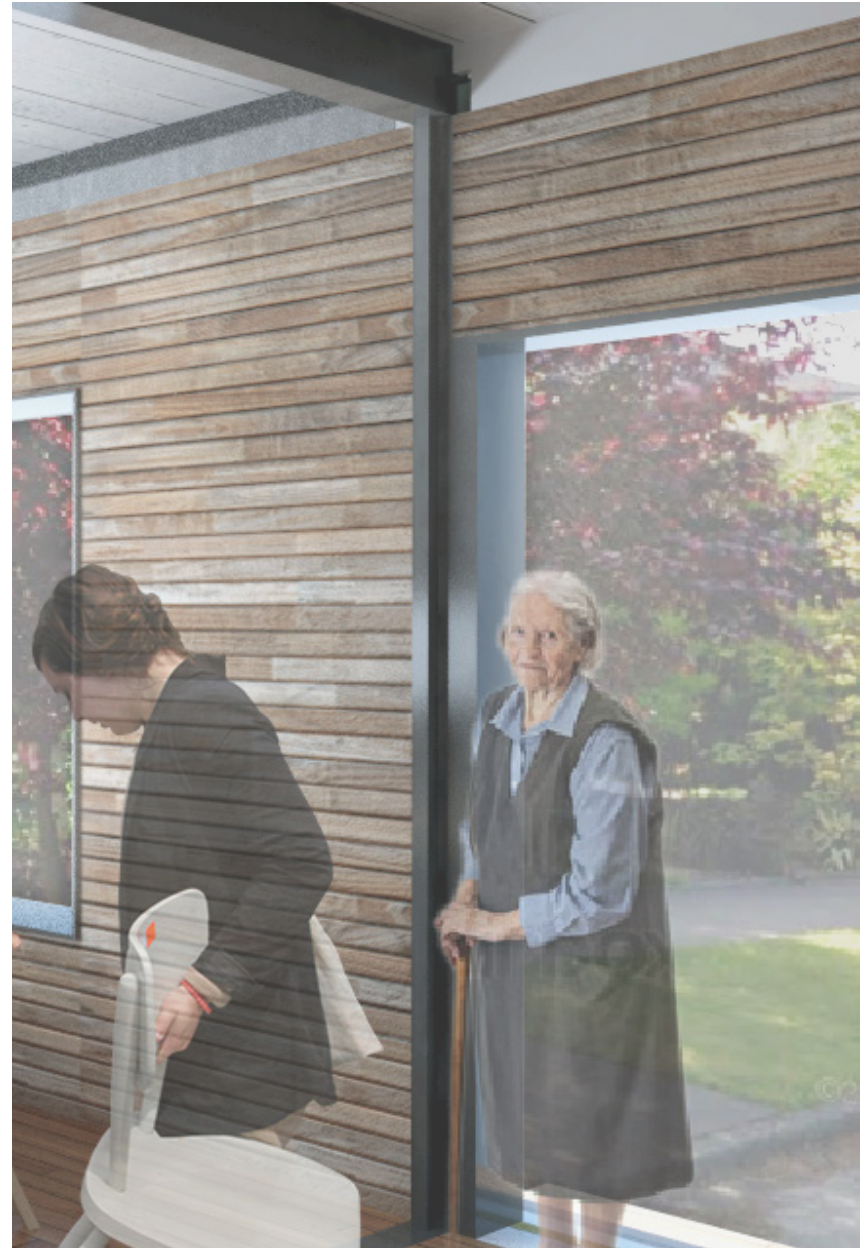

FIGURE 1.13: MODULARITY AND FLEXIBILITY
Modularity can allow for easy flexibility.

residents to incrementally expand or contract their living spaces through a modular approach thus: bring families back into urban neighborhoods through thoughtful multi-generational housing design, create a community of diverse ages, encourage a sustainable lifestyle, and address affordability in desirable urban neighborhoods.

CHAPTER 2: Theoretical Framework



Within a family style house, privacy is relative to the family structure, where public spaces are for family gatherings, instead of neighborhood events. For a multi-generational family, these definitions might change based on family culture.

Private space is that belonging to or for the use of a specific individual, or specific individuals. This relates to living spaces, in particular bedrooms and bathrooms – spaces in which people can take asylum. This could also be extrapolated to the entire house. Layers of privacy can be discussed, but for the sake of this thesis, “private spaces” are private within the family, instead of the general population. These private spaces require sequestration to quieter areas of the dwelling, and are generally more inward-focused.

Semi-private spaces serve as intermediary spaces between public and private, and act as a buffer between

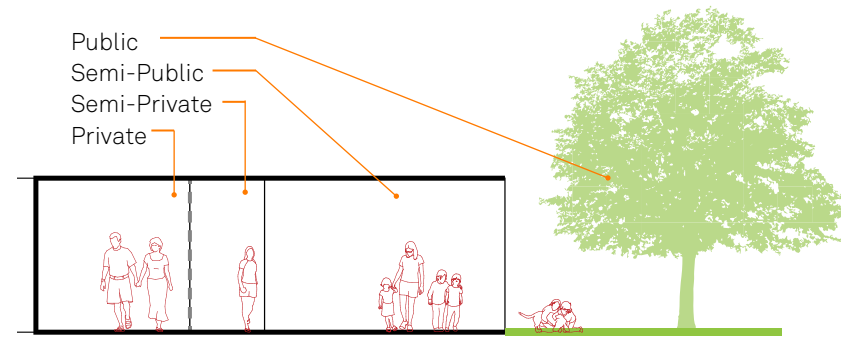

FIGURE 2.2: TYPES OF SPACES

Comprised of private, semi-private, semi-public, and public.

the two. Included in this definition are circulation space, studies, and recreation rooms. These spaces can be either closed off or opened up, depending on the current use.

Shared space is the most essential component to family-sized housing (multi-generational or traditional). These spaces are typically the exterior spaces, kitchen, dining room, and family room. Shared spaces enable open family interaction and provide safe locations for children to play. Successful execution of shared spaces is the lifeblood of family housing, and even more important for multi-generational housing.

2.2 Existing Multi-Generational Typologies

Currently there are few examples of multi-generational housing. There are some older, more historic examples and some recent developments to deal with the current evolution in family structure. The most prevalent are accessory dwelling units (ADUs), detached accessory dwelling units (DADUs), and multi-generational spec homes.

ADUs and DADUs are commonly known as “granny flats,” “in-law suites,” “backyard cottages,” “guest apartments,” or “secondary units.” There are numerous benefits to this typology. It is important to recognize that DADUs “are actually a throwback. [They] were common neighborhood features a century ago when multiple generations of a family lived together. By the 1950s, however, Americans were decamping for the suburbs,

pursuing the dream of a single-family home on a large tract of land. Many urban zoning codes of the second half of the century essentially banned the construction of new backyard cottages.”¹² They can easily be integrated into the existing single family context. ADUs and DADUs can provide a less expensive housing option with negligible negative impact on the quality of the neighborhood. Additionally, these units can also preserve a greater sense of privacy for all generations.

Spec-homes like Lennar’s NextGen homes are gaining popularity, and are a welcome addition to the lineup of multi-generational housing typologies. However, this concept suffers from the same problems as traditional single family homes in that they are spatially inflexible.

They offer further problems such as location, resources,

¹² Zach Patton, “Seattle Looks to Cottages for Affordable Housing,” *Governing*, May 2011, accessed April 20, 2016, <http://www.governing.com/topics/economic-dev/seattle-looks-cottages-affordable-housing-options.html>.

and finances.¹³ The location problem is the most troubling, as it relates to the other two: These spec-homes are built well outside urban areas. They are designed for young adults and senior citizens, both of whom have a strong desire to live in urban areas. “A recent study by the Wall Street Journal showed that 88% Millennials... want to live in an urban setting.”¹⁴ Therefore, the distance from desirable urban areas makes these homes less appropriate for their target audience. The resources problem is evident in the location. Because these homes are so far removed from urban centers, the resources needed to commute are higher than average. These houses also have very standard specifications and lack passive design strategies that would help reduce energy

13 Cavin Costello, “3 Failings of Lennar’s NextGen Multigenerational Homes,” Blooming Rock, January 23, 2012, accessed May 2, 2016, <http://bloomingrock.com/2012/01/23/3-failings-of-lennars-nextgen-multigenerational-homes/>.

14 Ibid.

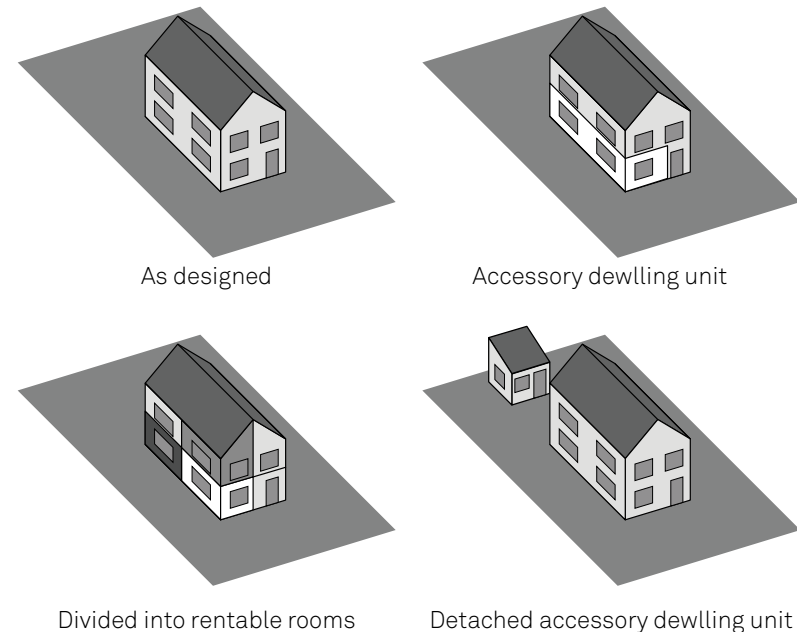

FIGURE 2.3: CURRENT WAYS OF HOUSING FLEXIBILITY
The four ways of dividing up a single family house.

consumption.¹⁵ And the financial burden of commuting and energy costs does little for those trying to cut down on costs, which was one of the main reasons why multi-generational living is making a comeback.

15 Ibid.

2.3 Expanding on the Existing Models

In most cases, the multi-generational spec-homes are located further away from the location their occupants wish to be. Locating the project within an urban single family neighborhood is the first necessary ingredient to a successful multi-generational typology. Closer proximity to transit-oriented urban neighborhoods maximizes mobility and reduces dependency on personal automobiles, thus reducing non-renewable resource consumption. Better location also places occupants closer to employment opportunities, schools, and other activities necessary for family living.

Multi-generational houses require flexibility to accommodate growing family structure. This aspect is something that the existing stock does not facilitate. Allowing for expansion and contraction provides many



FIGURE 2.4: HOW TO PROCEED

Video.

Create a framework of movable and removable walls within a modular system.

benefits to a multi-generational family. Creating a framework of movable partitions within the house and establishing a modular system that allows for incremental growth provides a near infinite amount of spaces.

2.4 Spatial Flexibility + Incremental Development

As lifestyles and stage of life changes, a flexible house can change as well. Through flexibility, a diversity of unit configurations can be created based on the individual preferences of the user. By taking inspiration from Japanese houses, in particular the expansion and contraction properties allowed by shoji screens, a flexible strategy can be developed. Allowing the walls to freely move and change means each unit can be expanded or contracted easier without abeyance of daily lives. Movable walls allow the spatial character of a room to change in relation to adjacent spaces. Therefore, a room could serve myriad different functions. However, thinking of flexibility in terms of shoji screens means there would typically be pre-existing structure for partitions to adhere to. However,

this thesis means to remove the existing structural framework from the equation, providing a visually cleaner approach to modularity, while allowing for walls to be altered quickly and easily. This would require a catalogue of prefabricated parts.

Incremental development is integral to a flexible concept of expansion and contraction. As previously mentioned, a flexible design can expand or contract based on the needs of the occupant. If the occupant needs more space later, they can add an additional module. This saves time and money compared to the traditional model of either purchasing a new house or undergo renovations.

2.5 Take-Away from Theoretical Framework

Flexible housing paired with incrementally adding or subtracting modules would accommodate the ideal family housing condition of having the house adapt to the family's changing spatial requirements, rather than the other way around. It also allows families to start by purchasing smaller units to accommodate smaller budgets, and expand from there. Designing for a multi-generational families would also allow for increased density in single family zones without subtracting from the feel of the neighborhood.

CHAPTER 3: Case Studies



3.1 Tatiana Bilbao's Sustainable House

Tatiana Bilbao designed a cost effective housing prototype that can be “adapted to suit varying numbers of residents, and can be expanded as a family grows. It can also be altered to suit the variety of climates around the country, by using a variety of materials and spatial layouts.”¹⁶ Its intentionally rigid core provides a base around which the house can be expanded. The core is composed of concrete, while the adjoining elements are modules composed of lighter materials, which allows for greater adaptability and expandability. Tatiana told Dezeen, “we used a modular system where not everything is finished with strong materials, sometimes its [sic] done

¹⁶ Amy Frearson, “Tatiana Bilbao Addresses ‘Urgent Need’ For Housing Mexico’s Poorest Inhabitants,” Dezeen, October 6, 2015, accessed April 22, 2016, <http://www.dezeen.com/2015/10/06/tatiana-bilbao-low-cost-social-housing-mexico-chicago-architecture-biennial-2015/>.

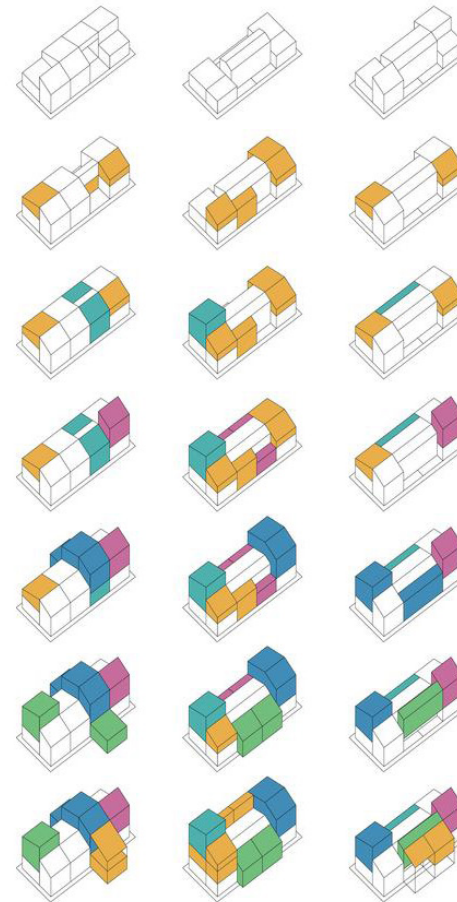

03
Sustainable House , Tatiana Bilbao Estudio

FIGURE 3.1: VARIABILITY

Source: Tatiana Bilbao

<http://www.dezeen.com/2015/10/06/tatiana-bilbao-low-cost-social-housing-mexico-chicago-architecture-biennial-2015/>.



FIGURE 3.2: VARIABILITY

Video.

Source: Tatiana Bilbao

<http://www.archdaily.com/775233/tatiana-bilbaos-8000-house-could-solve-mexicos-social-housing-shortage>

with an industrial palette... So it has more space, and with very much less [sic] money.”¹⁷ She also discovered, through working with the residents, that they want “a house that ‘looks like a finished house.’” And they want a pitched roof, specifically “a house that looks like a house.”¹⁸

¹⁷ Ibid.

¹⁸ Ibid

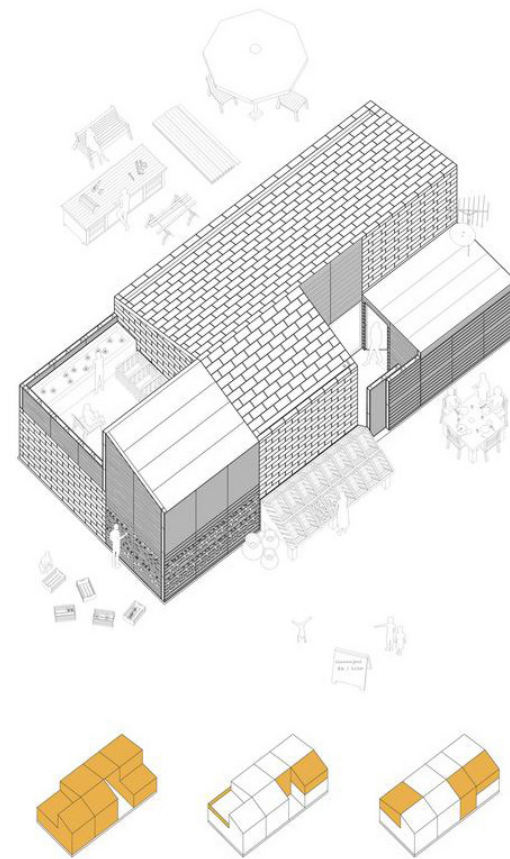

02
Sustainable House - Tatiana Bilbao Estudio

FIGURE 3.3: CORE + ADDITIONS

Source: Tatiana Bilbao

<http://www.dezeen.com/2015/10/06/tatiana-bilbao-low-cost-social-housing-mexico-chicago-architecture-biennial-2015/>.

3.2 ELEMENTAL's Villa Verde Housing

Elemental's Villa Verde Housing project in Chile is an excellent example of the principles of incremental construction. Initially, the houses are only half-built. This does not mean that the whole house is completed only partially. Instead, it means that a framework was built, and half of it was built to completion. The initial phase of the house sells between \$25,000 and \$40,000, which consists of a laundry room, bathroom, combined shared space (living room, dining room, and kitchen), and two bedrooms. As the owner needs more space, or has more money to completely fill in the framework, they can expand without needing to move. "In its initial phase the development comprises a terraced typology with each house separated from its neighbour by an undeveloped void. The pitched roofs form a continuous covering over this space and



FIGURE 3.4: INCREMENTAL CONSTRUCTION

Source: ELEMENTAL

<http://www.bdonline.co.uk/villa-verde-housing-chile-by-elemental/5062384.article>.

at first floor level joists are included that span to the adjacent party wall. Prior to further development these covered areas provide flexible usable spaces.”¹⁹

¹⁹ Hugh Strange, "Villa Verde Housing, Chile by Elemental," BDOnline, October 22, 2013, accessed April 30, 2016, <http://www.bdonline.co.uk/villa-verde-housing-chile-by-elemental/5062384.article>.

3.3 Traditional Japanese Houses

Edward Morse distills the essence of the Japanese house and clarifies the differences between the Japanese house and the typical Western house. Morse begins his description with, “The first sight of a Japanese house... is certainly disappointing.”²⁰ For the Western audience, who expect to see glazed windows, chimneys, permanent walls, light colored paint, sofas, etc., the Japanese house is unexpected. “An American finds it difficult indeed to consider such a structure as a dwelling, when so many features are absent that go to make up a dwelling at home... at least, so it appears at first sight.”²¹

Morse explains that the most surprising and

20 Edward Sylvester Morse, *Japanese Homes and Their Surroundings* (New York: Dover Publications, 1961), 6.

21 Morse, *Japanese Homes*, 7.

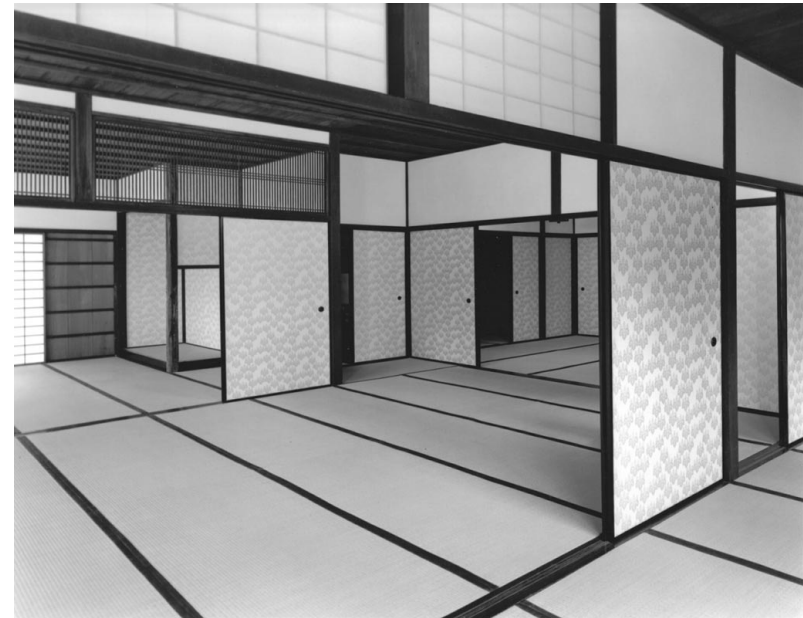

FIGURE 3.5: SHOJI AND SPATIAL FLEXIBILITY

Having movable walls allows for rooms to have multiple different configurations for different uses.
Source: Socks Studio; Location: Katsura Rikyuu, Kyoto.
<http://socks-studio.com/2016/05/15/the-imperial-villa-of-katsura-japan-1616-1660/>

possibly unsettling aspect of the Japanese house for Westerners is the lack of defined partitions. “In our houses, these [walls] are solid and permanent; and when the frame is built, the partitions form part of the framework. In the

Japanese house...there are two or three sides that have no permanent walls.”²² However, it is the interior spaces of the Japanese house that are exceptional. Foreign from the Western house’s permanence, the Japanese house is temporal, with parts that can be easily altered to accommodate the user. The absence of permanent walls allows a flexibility of purpose for the rooms. The impermanence of the walls are created by sliding screen doors that can be lifted up and removed from place to expand and contract rooms, and “a suite of rooms can be quickly turned into one, by the removal of the screens.”²³ This is expanded upon by the near lack of what Westerners consider furniture, such as beds and sofas. “The absence of nearly all furniture gives one an uninterrupted sweep of the floor, so that the entire floor can be covered with

²² Morse, 7.

²³ Ibid., 126.

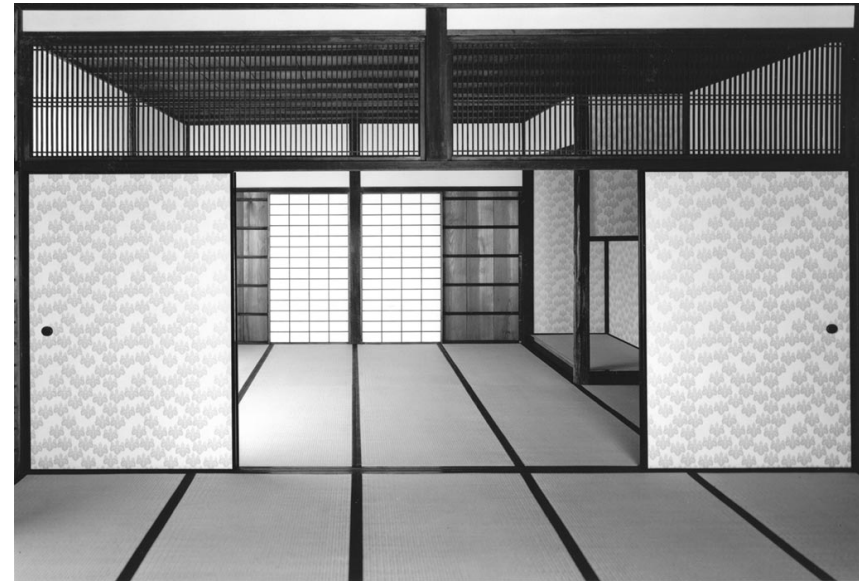

FIGURE 3.6: TATAMI AND SPATIAL REQUIREMENTS

One tatami mat is the proportions of one person. Using this as a reference can help determine size of modules in prefab units.

Source: Socks Studio, Location: Katsura Rikyuu, Kyoto.
<http://socks-studio.com/2016/05/15/the-imperial-villa-of-katsura-japan-1616-1660/>

sleepers if necessary.”²⁴ The Japanese house is a simple, inwardly-focused, multi-layered organic dwelling. It, however, as Morse writes, is not as simple and severe as it first appears, and is quite elegant in its subtlety.

²⁴ Ibid., 112.



FIGURE 3.7: CONNECTION TO NATURE

Having a connection to nature allows the space to feel larger. Source: Socks Studio; Location: Katsura Rikyuu, Kyoto. <http://socks-studio.com/2016/05/15/the-imperial-villa-of-katsura-japan-1616-1660/>

Life in traditional Japanese townhouses was symbiotic with nature. To make the space feel larger and to have a closer connection with nature, these homes had inner garden spaces, which the entire width of the

townhouse opened out into, connecting the interior and exterior spaces, “diverting one’s gaze from inside the rooms to the trees or rocks in the garden by the eaves that stretch out from the veranda space, emphasizing the connection to the garden.”²⁵

The measure and construction of the Japanese home is just as important as its elements. Rectangular, modular form allows for flexible design: “the rectangle is indeed the logical geometry of floor area, as it is the only form which allows the free addition of individual room units that in turn result in another rectangular shape, at the same time providing the basis for a most economical and simple construction.”²⁶

25 Takahiko Otani, “Architectural Theoretical Examinations of Typical Japanese Spatial Characteristics in Interior Spaces of Kyo-Machiya Townhouses,” accessed November 20 2015, http://www.mukogawa-u.ac.jp/~iasu2012/pdf/iaSU2012_Proceedings_203.pdf.

26 Heino Engel, *The Measure and Construction of the Japanese House* (Tokyo: Tuttle, 1985), 48.

3.4 Take-Away

To allow for variability in structure and in occupancy, Tatiana Bilbao used a more permanent core with less permanent modules that can be added as the spatial requirements demand. Elemental's half-built house approach to flexibility allows for the unbuilt, covered portions to provide flexible use spaces that can later be filled in as the resident builds financing. The Japanese house provides a methodology for spatial requirements through tatami, flexibility through shoji, and a connection to nature through interior gardens.

THIS PAGE IS LEFT INTENTIONALLY BLANK

PART 2: DESIGN RESPONSE



CHAPTER 4: Site Selection

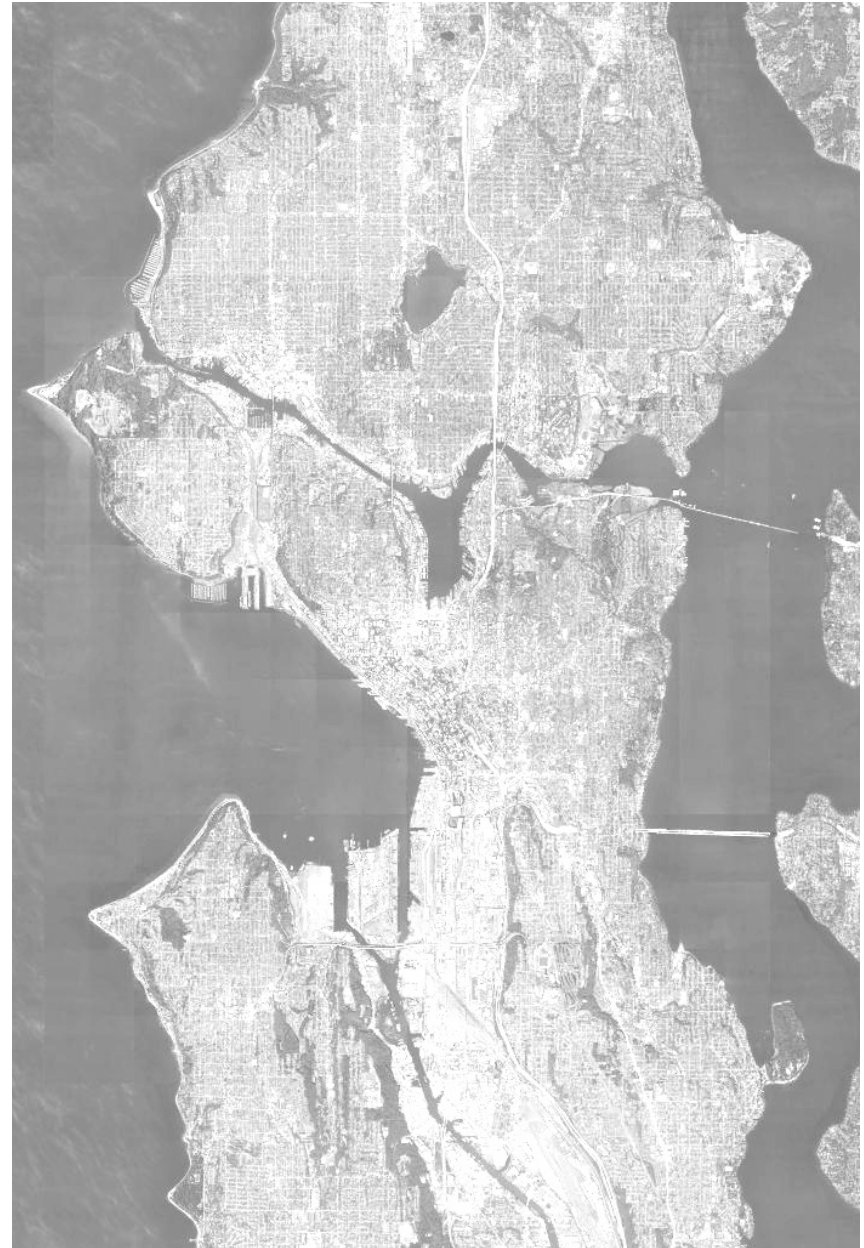

4.1 Seattle

The city of Seattle is an appropriate location for the exploration of this thesis. Throughout the city, most family-sized housing exists in the form of detached single-family residences. It is experiencing a population boom resulting in reduced housing stock and ever-increasing prices. Middle-class families are continuously priced and sized out of Seattle's single-family neighborhoods, moving farther afield. As they move out of the city's urban neighborhoods, a new group of people are moving in. The current people who are moving into the city are typically single, requiring either a studio or 1-bedroom unit. Seattle's average household size is 2.06 persons based on the 2010 census estimates. This implies that the majority of Seattle households are couples without children. The housing market is targeting this demographic, but does not

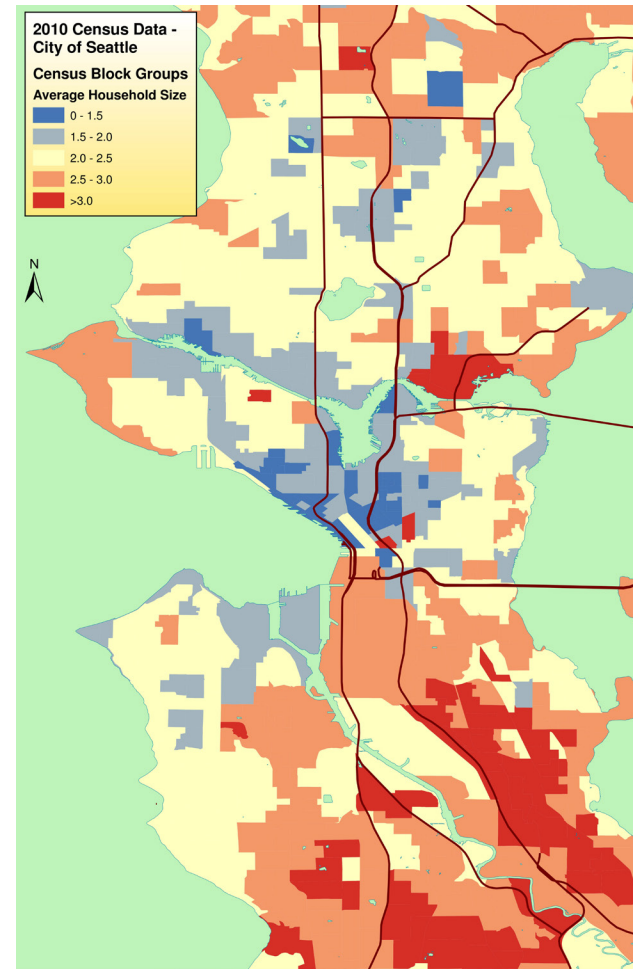

FIGURE 4.1: HOUSEHOLD SIZE IN SEATTLE

Urban neighborhoods have a shortage of families.
Source: Chad Newton,
<https://buildthecity.wordpress.com/2011/06/29/census-2010-average-household-sizes-in-seattle/>

take into account their future spatial requirements as the incoming population begins to couple and have children. Nor does it factor in the resurgence of multi-generational living.

In order for Seattle to be a city of growth and sustainability, its urban neighborhoods need to accommodate more families. As of 2009, 2 percent of market rate apartment units and 5 percent of condominiums and houses sold in Seattle had 3+ bedrooms.²⁷ 70 percent of the existing housing stock is studio and 1-bedroom units. When the current population of single adults becomes ready to start their families, the housing stock will be insufficient to meet their needs, and spatially inflexible for their changing lifestyles.

²⁷ "Family-Sized Housing: An Essential Ingredient to Attract and Retain Families with Children in Seattle," Seattle Planning Commission, January 2014, accessed April 10, 2016, pg 4. http://www.seattle.gov/Documents/Departments/SeattlePlanningCommission/AffordableHousingAgenda/FamSizePC_dig_final1.pdf.

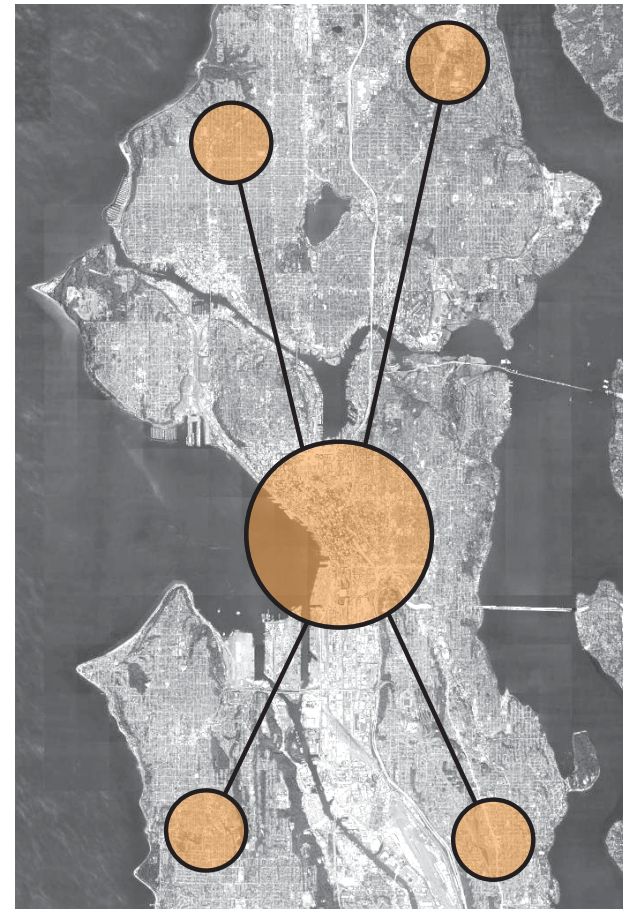

FIGURE 4.2: FAMILIES IN THE FRINGE
Seattle families are moving further out of the city due to lack of family sized units and affordability.

The current housing stock is also unaffordable for much of the middle class. In the State of Washington, middle income families are those that earn between \$38,937 and \$116,810 per year.²⁸ The real median household income in Seattle is \$71,273. This means that a Seattle household must make around \$1,367 per week to hit this average. The average home value in Seattle as of March 2016, based on Zillow market research, is \$557,700, with an annual increase of 16.7 percent. Whereas the average value for a single family house is \$610,000.²⁹ And the cost of renting is rapidly increasing. In 2015, apartment rents in King and Snohomish counties “jumped nearly 5 percent in the second quarter and almost

28 Libby Kane and Andy Kiersz, “How Much You Have to Earn to Be Considered Middle Class in Every US State” Business Insider, April 2, 2015, accessed April 10, 2016, <http://www.businessinsider.com/middle-class-in-every-us-state-2015-4>.

29 “Market Overview: Seattle Metro,” Zillow, April 2016, accessed April 23, 2016, <http://files.zillowstatic.com/research/public/realestate/ZHVI.Seattle.395078.pdf>

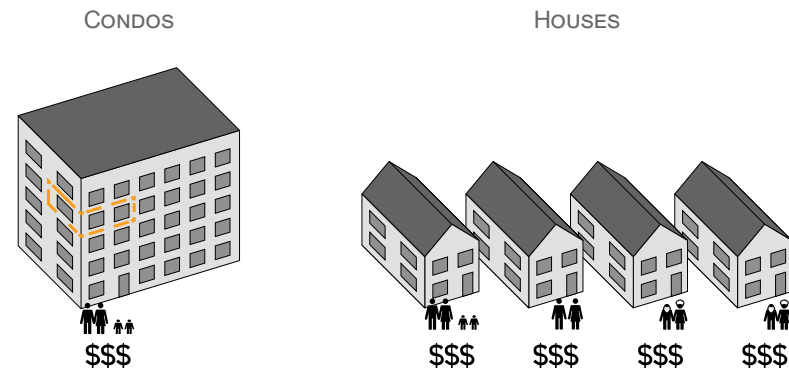

FIGURE 4.3: ESTIMATED COST COMPARISON

As of November 2016, the average monthly rent of a 2-bedroom apartment is higher than the average monthly payment on a 30-year mortgage.

10 percent over the past 12 months, according to a new survey;” meanwhile, vacancy rates fell to its lowest since 2005, in areas like Ballard to 6.9 percent.³⁰ According to the website Rent Jungle, “as of February 2016, average

30 Sanjay Bhatt, “Apartment Rents in King, Snohomish Counties Jump 5 Percent in 3 months,” The Seattle Times, July 2, 2015, accessed April 10, 2016, <http://www.seattletimes.com/business/real-estate/local-apartment-rents-up-almost-5-percent-in-3-months/>.

apartment rent within 10 miles of Seattle, WA is \$1,754.”³¹ The average rent for a 2-bedroom apartment is \$2,125. This is an increase of \$520 per month, or 42 percent, since 2011. The ideal monthly housing payment (including principal, interest, insurance, and taxes) is about 28 to 30 percent of gross income. This front-end ratio is becoming less viable as an increasing number of households are spending more than 30 percent of their income on their housing payments.³² With a household income of \$71,273, a monthly rent of \$1,754 is greater than 30 percent of their annual income. As it stands now, middle-income families will not be able to affordably live in the city with a sensible budget.

31 “Rent Trend Data in Seattle, Washington,” Rent Jungle, accessed April 10, 2016, <https://www.rentjungle.com/average-rent-in-seattle-rent-trends/>.

32 Karen Weise, “Housing’s 30-Percent-of-Income Rule Is Nearly Useless” Bloomberg, July 17, 2014, accessed April 10, 2016, <http://www.bloomberg.com/news/articles/2014-07-17/housings-30-percent-of-income-rule-is-near-useless>.

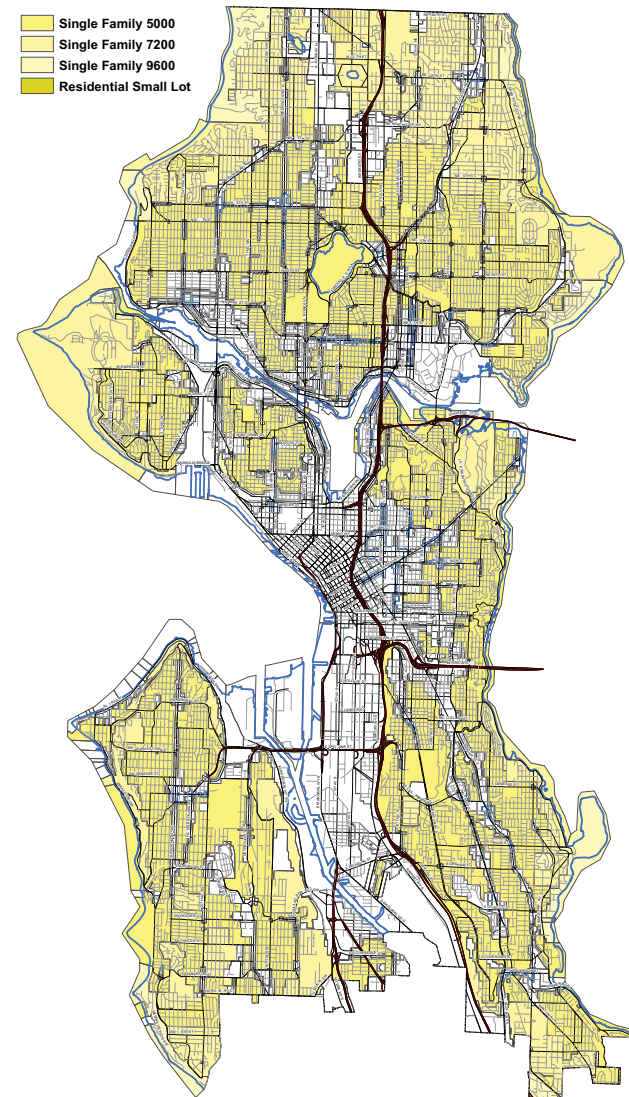

FIGURE 4.4: SINGLE FAMILY ZONES
The most prevalent zoning in the city.

4.2 Example Neighborhood: Wallingford

In order to address affordability in desirable urban neighborhoods, the site must be located close to schools, transit, retail, parks, and middle-income employment opportunities. The site must be a block in a residential zone. At least 1/3 (33 percent) of the neighborhood must be families, and at least 1/3 (33 percent) of the population must have home-ownership. It also must be difficult for middle income families to find housing in this neighborhood. This means the neighborhood must be expensive, have a relatively high turnover rate, and have a high percentage of homes sold above asking price. However, this is a prototypical design, and can be implemented anywhere in the Seattle metropolitan area.

Wallingford fits the criteria. Its median home value is \$742,100, which is an increase of 17.5 percent in the past

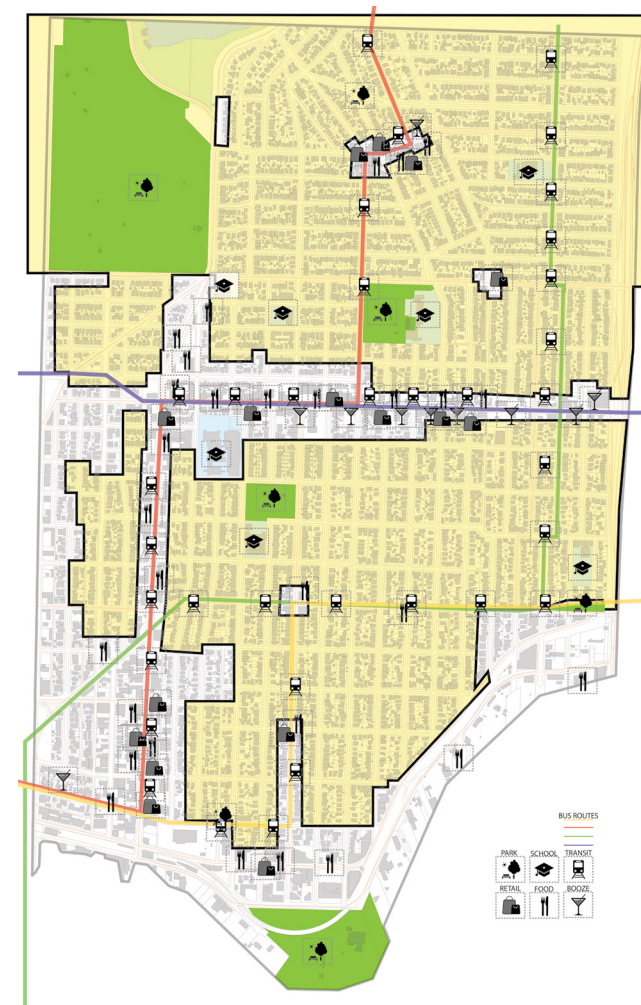

FIGURE 4.5: WALLINGFORD MAP
Map of amenities and single family zoning in Wallingford.

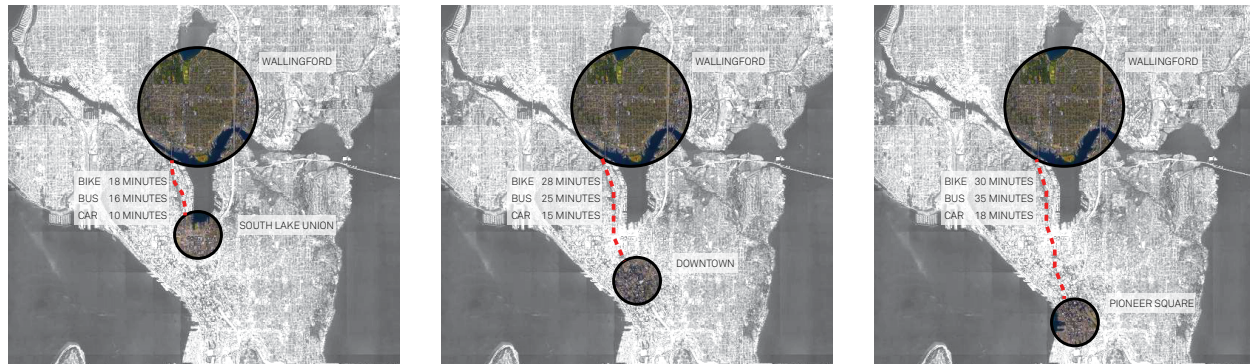

FIGURE 4.6: WALLINGFORD PROXIMITY
 Wallingford's relationship to places of employment.

year. The median household income is \$72,996, very close to the city's average. 38.1 percent of the neighborhood own their living arrangements, and 35.7 percent of the neighborhood are families.

Wallingford is a highly desirable neighborhood. It is a neighborhood rife with quality schools, parks, and retail shops and restaurants. There are four major transit routes through the neighborhood. Because of this, commuting time to major employment centers is minimal. By bus, it takes roughly 15 minutes to reach South Lake Union,

25 minutes to reach downtown, and 35 minutes to reach Pioneer Square. It is also a centrally located neighborhood, bordering the U District, Fremont, and Green Lake. Because it is so desirable, family sized units are hard to come by. According to a survey done by Estatefy in February 2016, 54 percent of houses in Wallingford sold in under 8 days, and 40 percent sold above the asking price.³³

³³ Ryan Nickum, "Seattle's Hottest & Coldest Neighborhoods for Real Estate," Estatefy, February 8, 2016, accessed April 29, 2016, <http://blog.estatefy.com/2016/02/seattles-hottest-coldest-neighborhoods-for-real-estate/>.

4.3 Specific vs Generic Sites

Although Wallingford is discussed as a desirable neighborhood in need of family-sized housing units, this thesis does not have a specific site, rather various prototypical sites following three prevalent lot conditions throughout the city: a corner lot, an infill lot, and an alley lot. Alley lots and corner lots are more advantageous, since they allow for two points of entry to the site. This not only helps create separate sense of space for the residents, but it also helps with the ease of assembling and disassembling modules. The infill lots pose the most difficult circumstance, whereby there is only one access point to the site. To allow the infill lot to accommodate multiple entrances and module assembly, a 16'-0" drive aisle must be present. This is notably restrictive with one parcel, but can be overcome if two adjacent parcels were

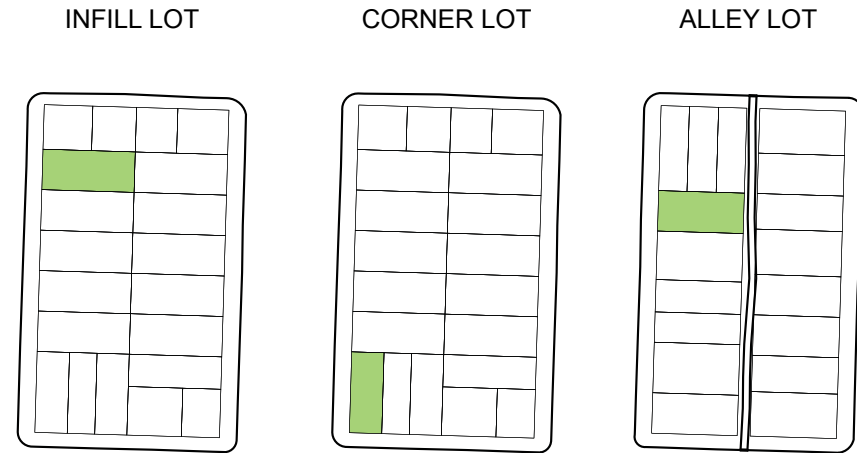
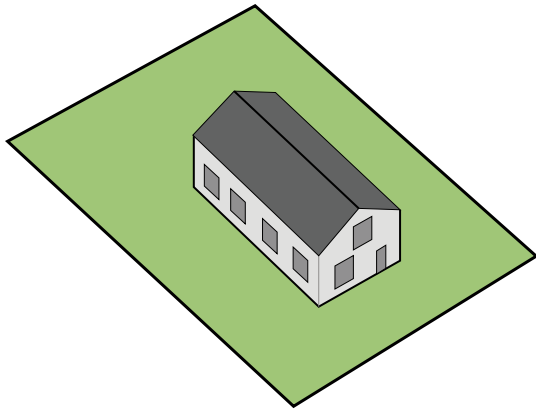

FIGURE 4.7: PROTOTYPICAL SINGLE FAMILY LOTS
The majority of Seattle Single Family lots are roughly 50' x 100', but do vary considerably throughout the city.

to choose this prototype.

The prototypical lots fall within the single family zoning prescription, however, to allow for the design to accommodate the desired density, amendments to the code for specific lots would be required. The proposed development would take on a zoning closer to low rise on the specific lot. Again, this thesis will not discuss the zoning code changes in depth.

SINGLE FAMILY ZONING



SETBACKS

Height: 30' max
Side Yard: 5' min
Front Yard: 20' min
Rear Yard: 20% Lot Depth
Lot Coverage: 35% max

SINGLE FAMILY DENSITY

1 Family = 1 Unit

LOW RISE ZONING

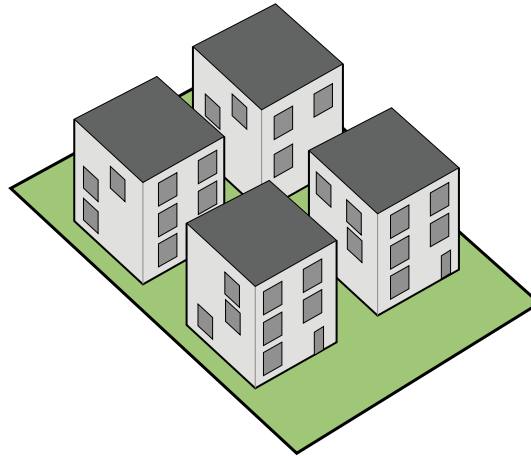

SETBACKS:

Height: 30' + 5'
Side Yard: 5' min
Front Yard: 7' average, 5' min
Rear Yard: 0' w/ Alley, 7' w/o

LOW RISE DENSITY

4 Families = 4 Units

PROPOSED ZONING

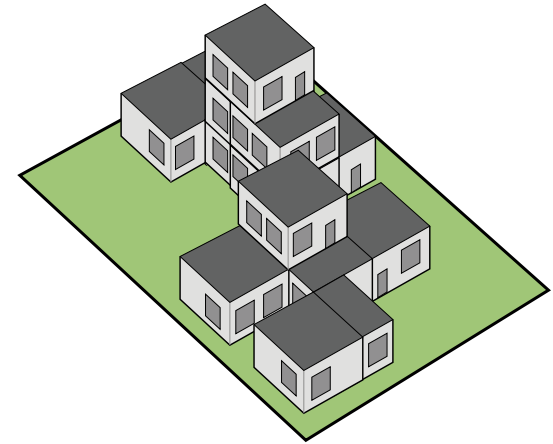

SETBACKS:

Height: 30'
Side Yard: 5' min
Front Yard: 5' min
Rear Yard: 5' min

PROPOSED DENSITY

1 Extended Family = 2 - 8 Units

FIGURE 4.8: EXISTING VS PROPOSED ZONING
General setbacks and density in SF and LR zones.

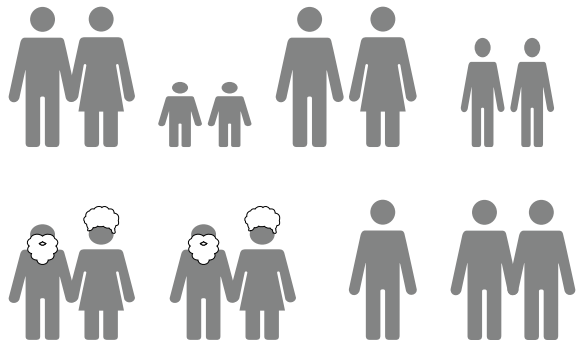

FIGURE 4.9: FAMILY STRUCTURE AND USER GROUP
Potential user group.

4.4 Users

The target users for this thesis are middle-income families at various stages in life, with a leaning toward multi-generational living. Occupants are variable and numerous, but can be broadly classified as follows: a single person; a young couple; a couple with kids; a couple with parents; a couple with kids and parents; a couple with kids, parents, and a boarder; a couple with kids, parents, a boarder, and sibling; and an older couple.

4.5 Program

A typical single family residence has fairly simple program elements. These are cooking spaces, living spaces, sleeping spaces, eating spaces, storage spaces, work spaces, recreational spaces, sanitary spaces, outdoor spaces, and circulation. However, to make efficient modular units, many of these spaces, in particular the spaces that do not require plumbing, can be simplified into flexible space.

The program is defined by modular units. These units are developed through a series of appropriate sizes for each type of space. In Japanese design, spatial measurement is based on a tatami mat.³⁴ Tatami mats illustrate space per person and thus can be extrapolated into program space. What is deemed appropriate is

³⁴ A tatami mat is roughly three feet by six feet. It is equivalent to the prostrate human body, or two seated or standing bodies.

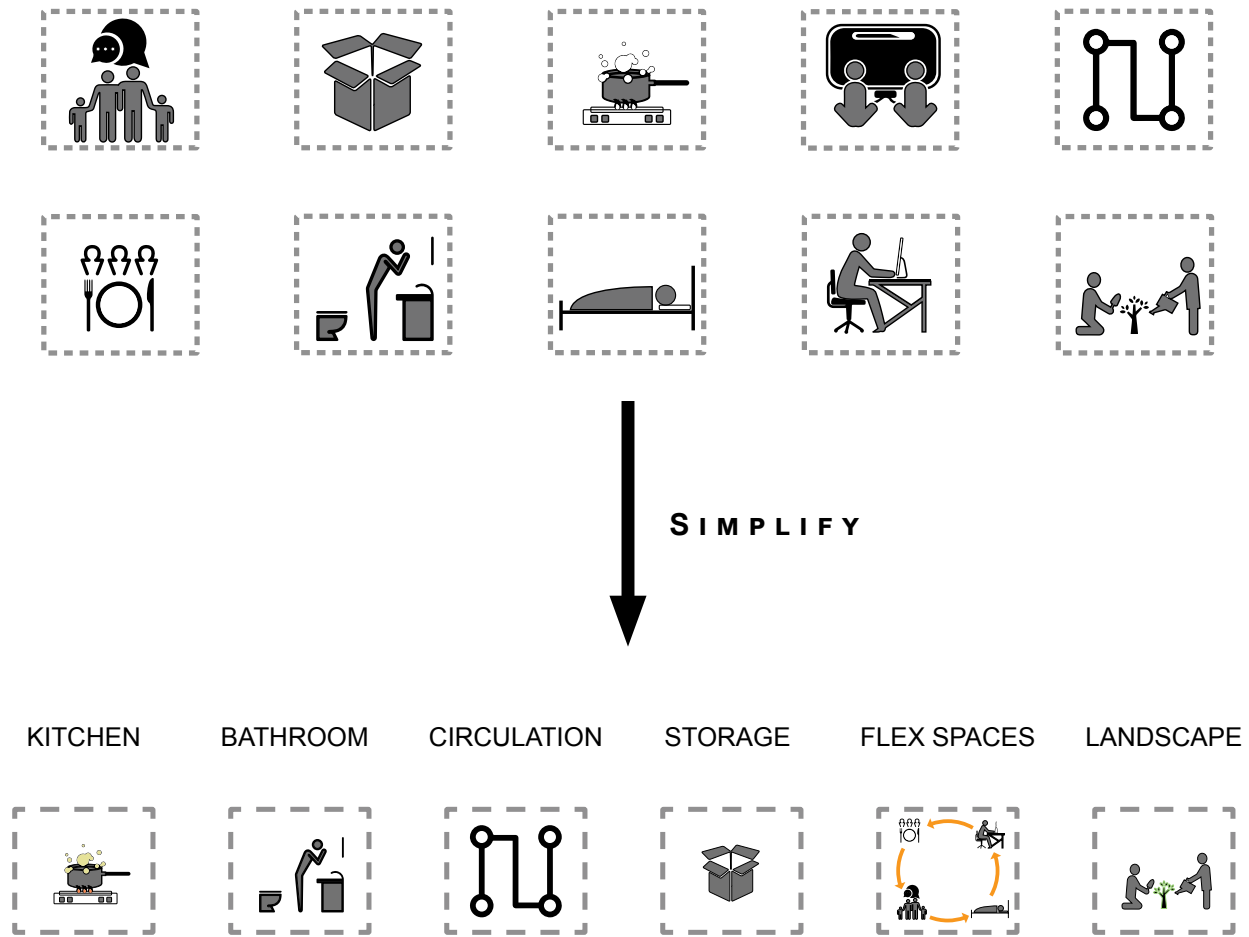

FIGURE 4.10: PROGRAM TO MODULES
 The 10 elements of a typical single family house are simplified into their most basic functions.

devised from an interpretation of the tatami mat. These appropriate sizes are called modules, where one module equals 4 feet by 8 feet, on center. These modules are larger than a tatami mat to fit a more American context, as well as being a standard premanufactured material size in the US. Each unit is derived from this dimension.

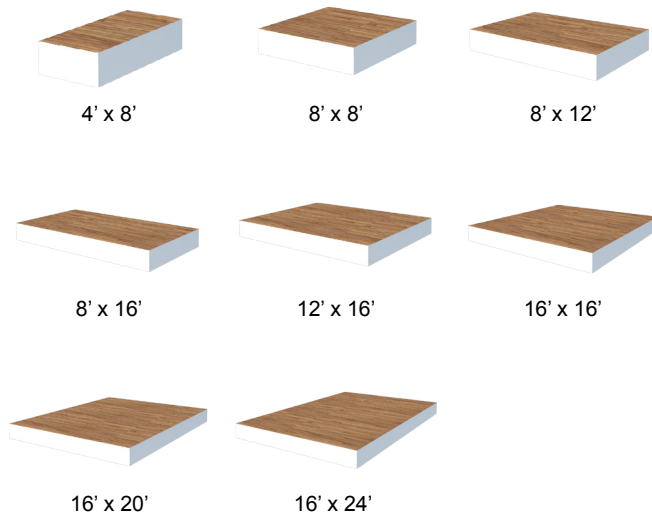

FIGURE 4.11: DIMENSIONS OF MODULES

Each module is based off a 4' x 8' base module, and expanded from there.



FIGURE 4.12: PROGRAM SPACE PER RESIDENT

Video.

As a family evolves, it not only needs more space, it requires different types of spaces as well.

CHAPTER 5: Design



5.1 Design Considerations

The objective of this thesis was to re-introduce family-sized housing in urban neighborhoods through the lens of multi-generational families by using modular, flexible design. To accomplish this, the prototype must be an evolution of traditional single family housing paradigms. For traditional single family housing and its evolutions, context, comfort, and privacy are the most

important aspects for design.

The new typology should fit within the existing context of a single family neighborhood. As such, the height of these prototypes will keep with existing zoning, as mentioned in the previous chapter. As also mentioned in the previous chapter, but worth noting here, the lot coverage and setbacks will deviate from the traditional single family restrictions to accommodate the increased density and to allow for the flexibility needed.

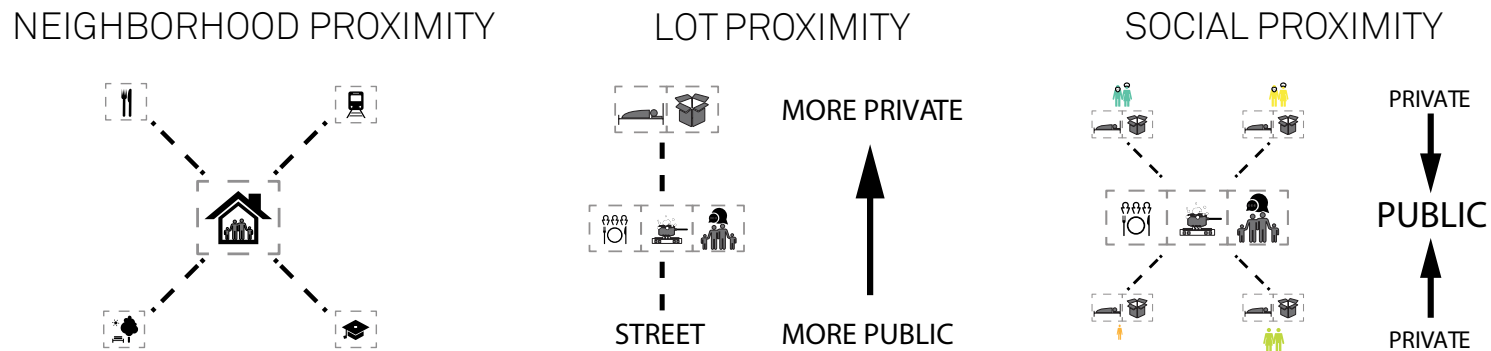

FIGURE 5.1: DESIGN CONSIDERATIONS
When designing for families, proximity plays a crucial role.

The interior spaces should be comfortable to facilitate all stages of life. Like in all housing, ventilation acoustic, and lighting comfort need to be addressed. Operable windows and relatively open floor plan provide passive ventilation. Keeping the noise sensitive areas sequestered from active spaces and having movable interior partitions help acoustic comfort. In addition, plenty of generous windows with shading devices and high ceilings keep the spaces light-filled and reduce glare.

Privacy and spatial relationships are important in multi-generational housing. Each occupant has different privacy needs, such as separate entrances for specific occupants. There is also a greater need for distinction of the relationship between spaces. An important relationship to consider is that the common areas play more significant roles, as they have to accommodate the expanding family dynamic.

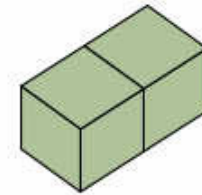

FIGURE 5.2: CONCEPT FOR SPATIAL FLEXIBILITY

Video.
Flexibility of spaces should be easy.

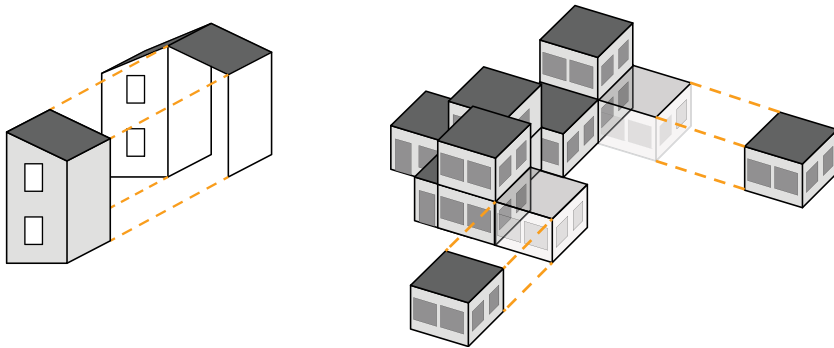

FIGURE 5.3: FIXED STRUCTURE VS FLUID STRUCTURE
Having a fixed structure is too limiting.

Flexibility is paramount to the success of this prototype. The housing needs to be flexible enough to accommodate demographic and lifestyle changes. It addresses the need to adapt to changing family dynamics and allows for continuous integration of new modules. This flexibility is resolved through a strategy of expanding and contracting, depending on the family size and structure of its residents.

5.2 Design Logic

Architecture should be contextual and site specific. However, when designing for prototypical conditions with modular components, a sense of specificity gets removed. To bring it back into the equation, walls have to be separate entities and configurable in multiple ways. By separating the wall components from the floor and ceiling components, flexibility and configurability are increased.

To increase the flexibility further, no predetermined structure will be on site. Module-based housing often has a pre-existing structural framework to allow for a “plug-n-play” mentality. This way of expanding a house is limiting. Therefore, this design proposes a more fluid approach of having the structural components integrated into the modules.

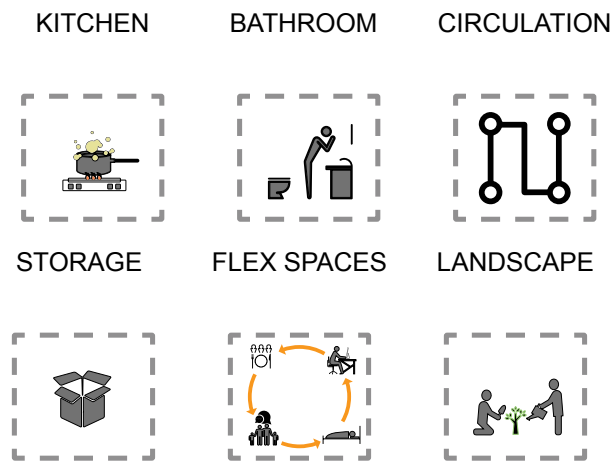

FIGURE 5.4: MODULE TYPES
Program simplified into modules.

In order to impose some constraints on the design, and to allow for connections to light and nature, each house must have at least three light well or courtyard spaces.

Each module is comprised of at least a floor component and structural framing. Conditioned modules are also comprised of exterior wall components, interior wall components, and roof component.

5.3 Module Types

As explained in chapter 4.5, the many program elements of a single family house were condensed into six basic modules: kitchen, bathroom, vertical circulation, storage, flexible space, and landscape. There is a predetermined number of each module for the occupant to choose from. This strategy allows the occupant to have control over the flexibility and hierarchy of spaces.

Because these spaces are designed with a multi-generational family in mind, larger kitchens and bathrooms are required to support ADA requirements and a larger number of occupants. The flexible spaces modules vary in sizes to adapt to a variety of configurations and uses.

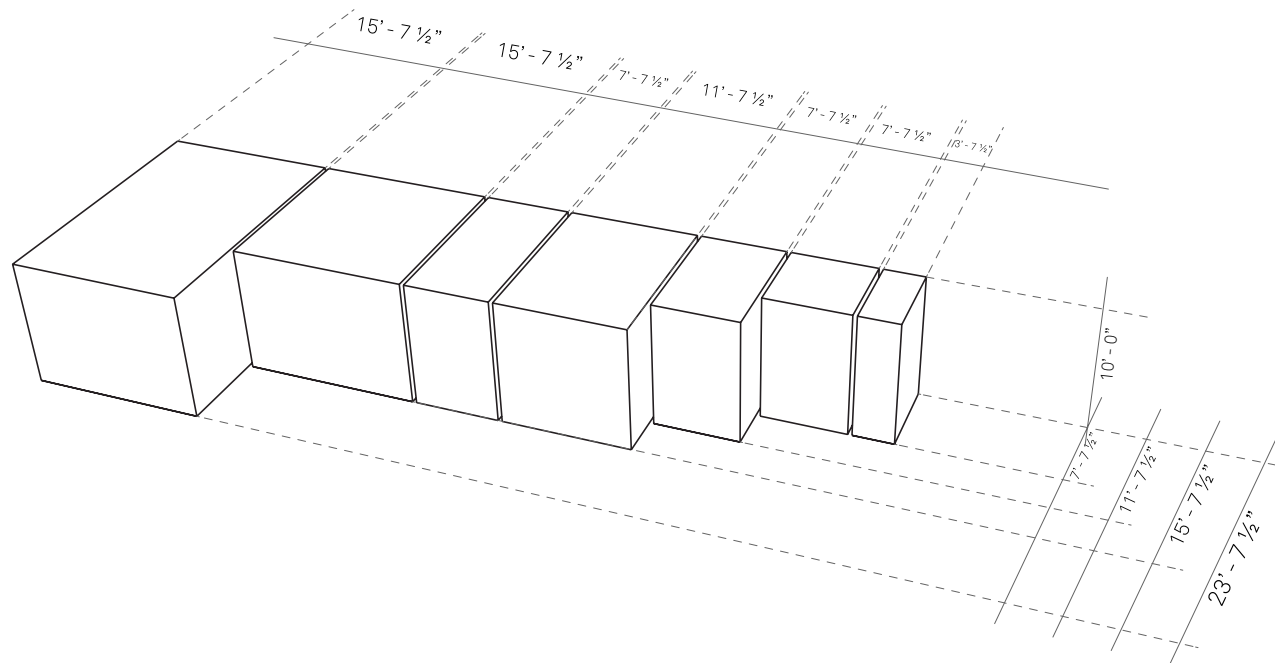

FIGURE 5.5: MODULE VOLUMES

Each module is based of a 4' x 8' on center base, with 4 1/2" structure in between, making the smallest size of the floor component 3'-7 1/2" x 7'-7 1/2".

KITCHEN



SMALL
12' x 16'



LARGE
16' x 16'

BATHROOM



POWDER ROOM
4' x 8'

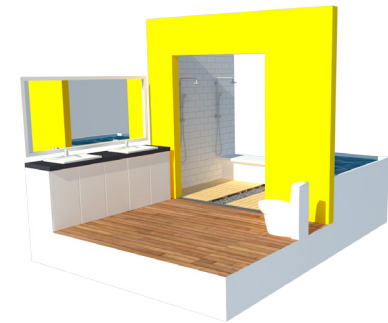

FULL BATH
12' x 16'

FIGURE 5.6: KITCHEN MODULES

Two kitchen modules allow for different configurability. Both are large enough to accommodate a variety of family sizes.

FIGURE 5.7: BATHROOM MODULES

Two bathroom modules allow for different configurability.

CIRCULATION



STAIRS
W/O STORAGE
8' x 12'

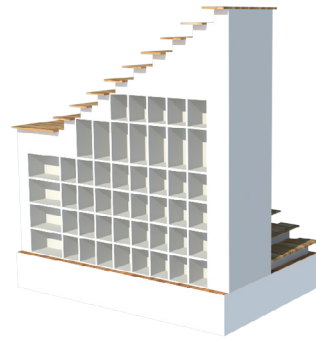

STAIRS
W/ STORAGE
8' x 12'

STORAGE

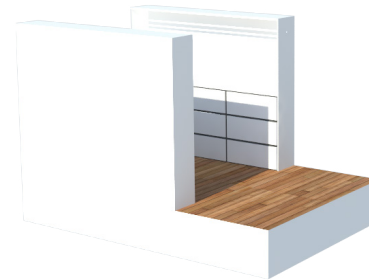

CLOSET
8' x 12'



LAUNDRY
8' x 8'

FIGURE 5.8: STAIR MODULES

The stair with storage would be a ground level unit, whereas the stair without storage would be for third floor access.

FIGURE 5.9: STORAGE MODULES

Laundry and closet modules provide the basis for storage. Other storage can be accommodated in the flexible space modules.

FLEX SPACES

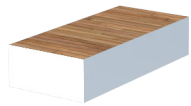

4' x 8'

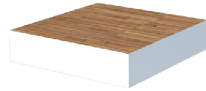

8' x 8'



8' x 12'



8' x 16'



12' x 16'



16' x 16'

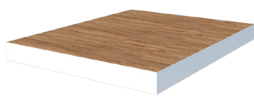

16' x 20'

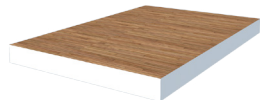

16' x 24'

FIGURE 5.10: FLEX SPACE MODULES

Flexible spaces can accommodate a variety of program elements, such as living room, bedroom, study, entertainment room, storage, and so forth.

LANDSCAPE

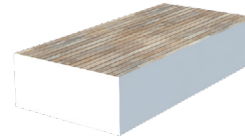

SMALL HARDSCAPE

4' x 8'



SMALL LANDSCAPE

4' x 8'



LARGE LANDSCAPE

8' x 12'



LARGE LANDSCAPE W/ TREE

8' x 12'

FIGURE 5.11: LANDSCAPE MODULES

Landscape modules allow for the landscape elements to be designed, rather than just being leftover spaces. They create a better relationship between interior and exterior spaces.

5.4 Constructibility

Each module is constructed from prefabricated kit-of-parts components in a warehouse off-site to allow for controlled environments, reduced delays, precision, and mass-production. Once all of the components are ordered and inventory is taken, they can be assembled into modules. The basic structure is a steel frame system with cross-laminated timber (CLT) infill panels. As mentioned earlier, the frame is 4 1/2 inches thick, which is the thickness of a 3-ply CLT panel.

Exterior walls are 11 inches thick to accommodate the 4 1/2 inch frame and CLT panel, 5 1/4 inches of rigid insulation, 3/4 inch air barrier, and 1/2 inch cladding. Interior walls are either large sliding doors for flexible spaces or CLT panel over the frame. The floors are 20

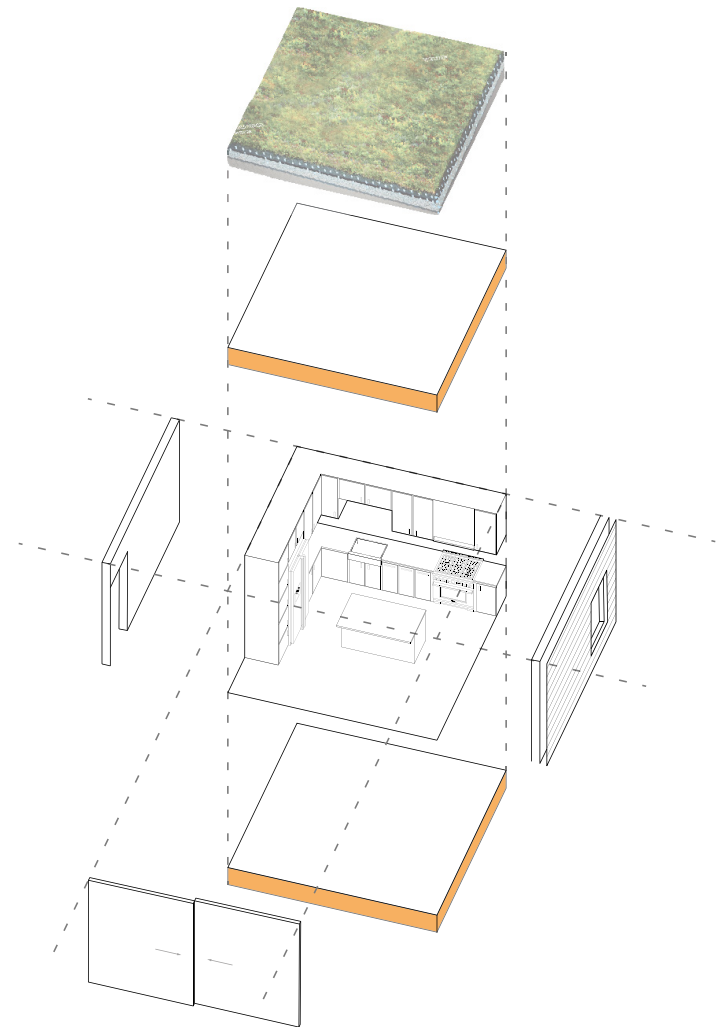

FIGURE 5.12: FABRICATION OF MODULE
The modules are constructed from pre-cut and prefabricated wall, floor, and roof components.

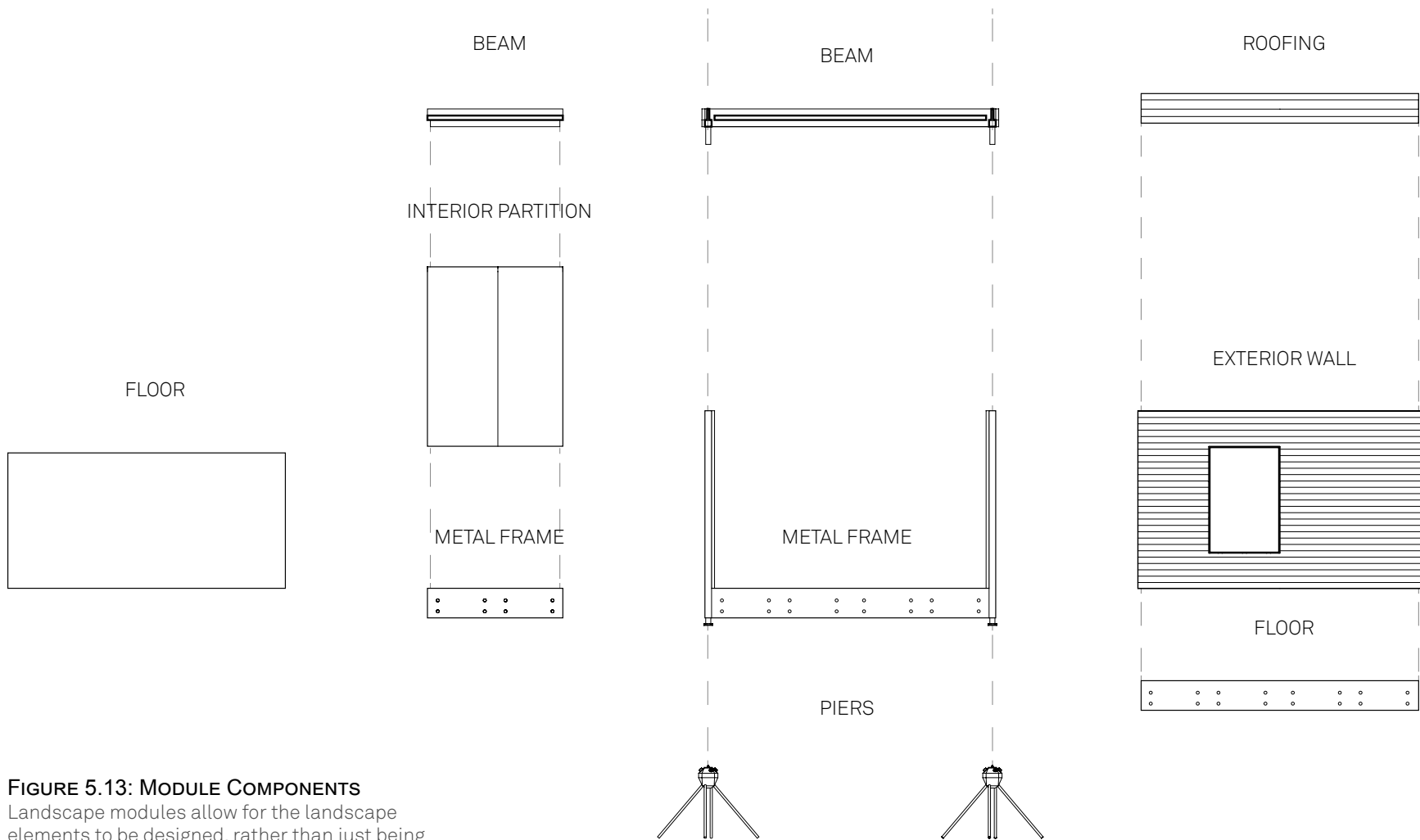

FIGURE 5.13: MODULE COMPONENTS
 Landscape modules allow for the landscape elements to be designed, rather than just being leftover spaces. They create a better relationship between interior and exterior spaces.

inches thick and contain utilities. They are made up of 4 1/2 inches of CLT, 6 1/2 inches of rigid insulation, framing to contain up to a 6 in diameter pipe, and 1/2 inch plywood. The internal framing of the floor panels connect to the overall structural frame of the module. The frame connects to piers to allow for very little site-work and a soft touch on the site.

The hyperrectangular (three-dimensional rectangle) geometry of the modules allows the flexibility to adjoin and stack. Platform frame construction also facilitates its flexible nature. The interior partitions in the form of large sliding doors are easily removed to open up space to allow for greater flexibility of spaces as well as making it easier for the whole house to be reconfigured.

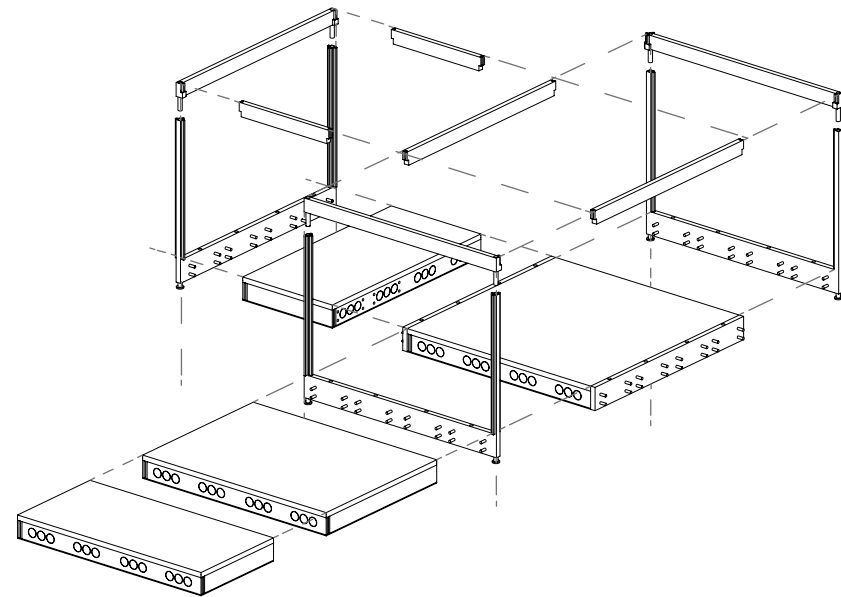

FIGURE 5.14: STRUCTURAL ASSEMBLY

A steel framework integrated into each module allows for greater flexibility and removes the clutter of a static structural frame with infill modules.

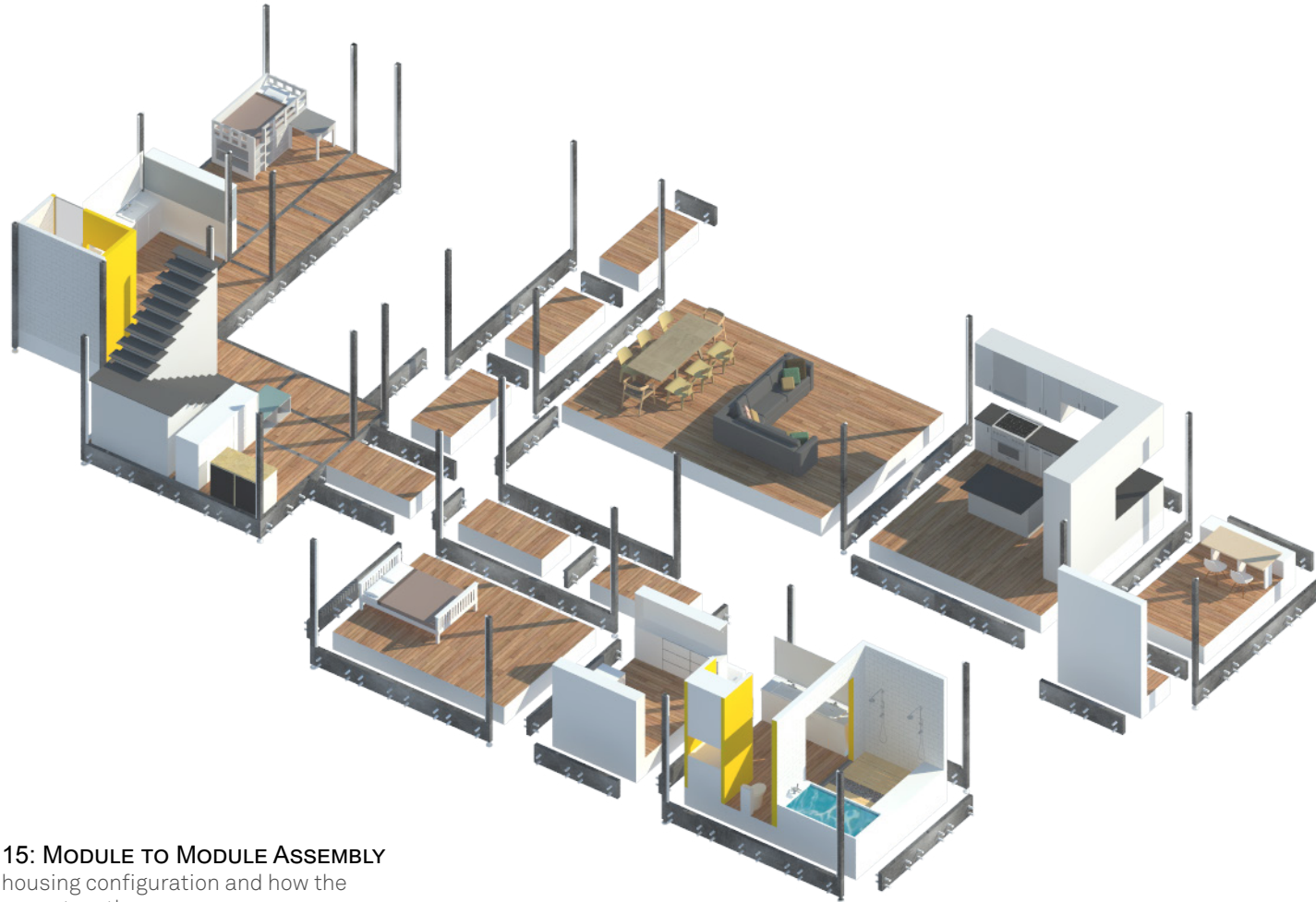

FIGURE 5.15: MODULE TO MODULE ASSEMBLY
A possible housing configuration and how the structure comes together.

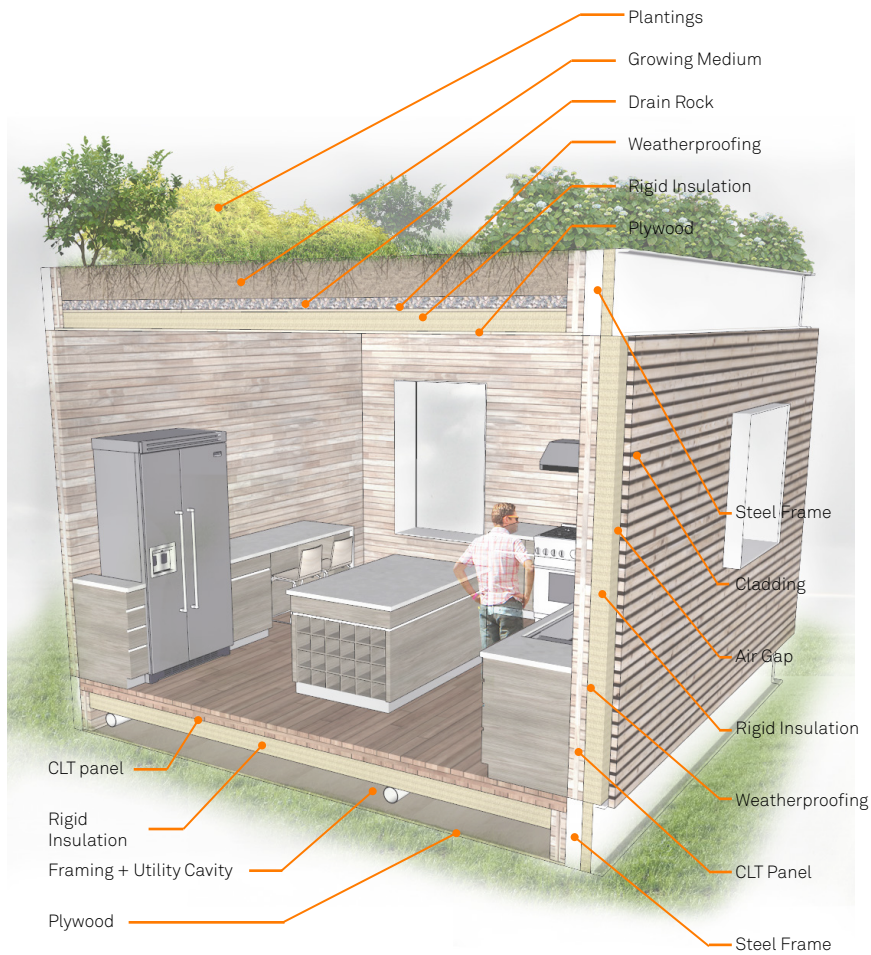

FIGURE 5.16: SECTION PERSPECTIVE
 Showing floor and wall details.

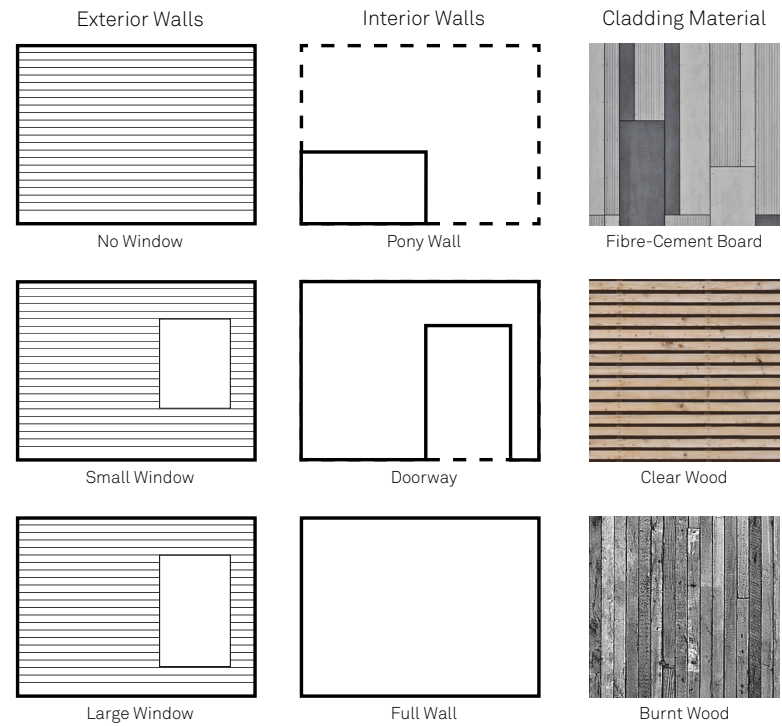

FIGURE 5.17: WALL TYPES AND MATERIALS
 Occupants choose their wall type and material based on what module, and wall location.



FIGURE 5.18: WEBSITE

Website helps the ease of self-design, ordering, and community aspects.

5.5 Accessibility + Website Design

In order for this prototype to be accessible to people in the modern era, a website is required to get information, contact designers, and place orders for houses. The website walks potential homeowners through the process of ordering modules, choosing a base design, or designing their own house with the help of a representative. All of the permutations that exist for this housing typology are stored within the site, and makes the process easier for the user to understand.

When first logging on, the users input the address of the project, and selects site conditions. Then they decide whether they want to contact a designer, choose a module, or choose a base design. The designer will come up with a strategy for the layout of their house; choosing a module will walk them through which module, which walls, and

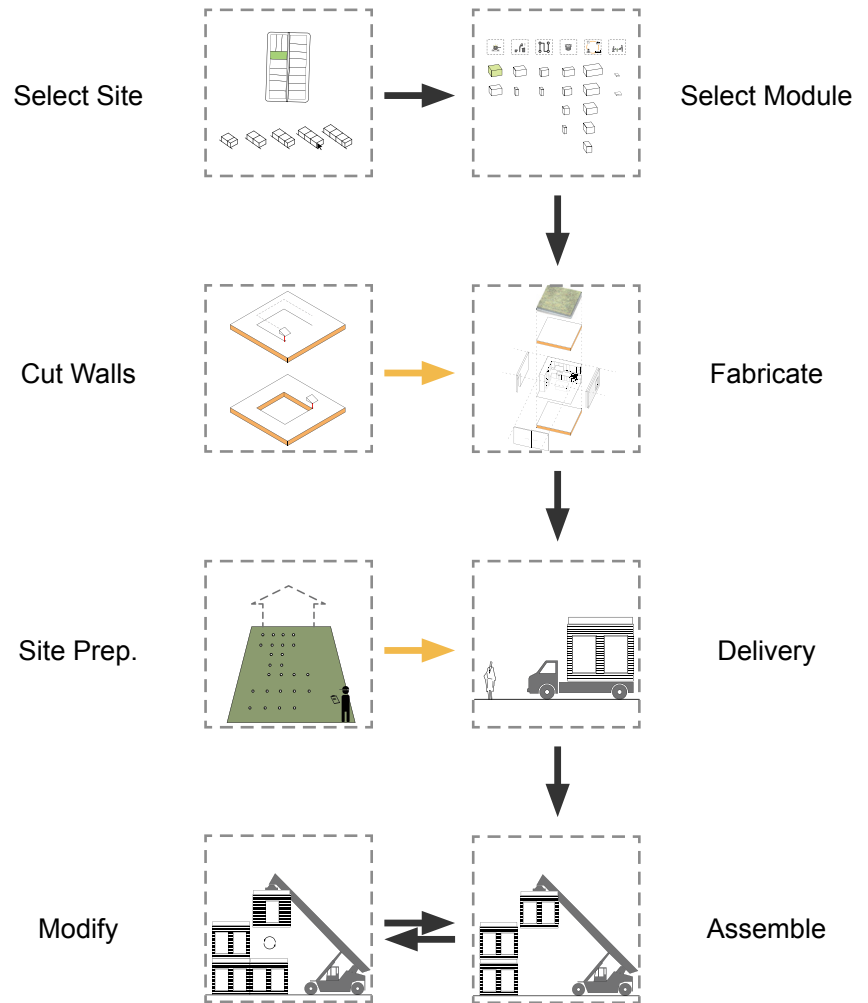

FIGURE 5.18: PROCESS
Process from ordering to on-site assembly.

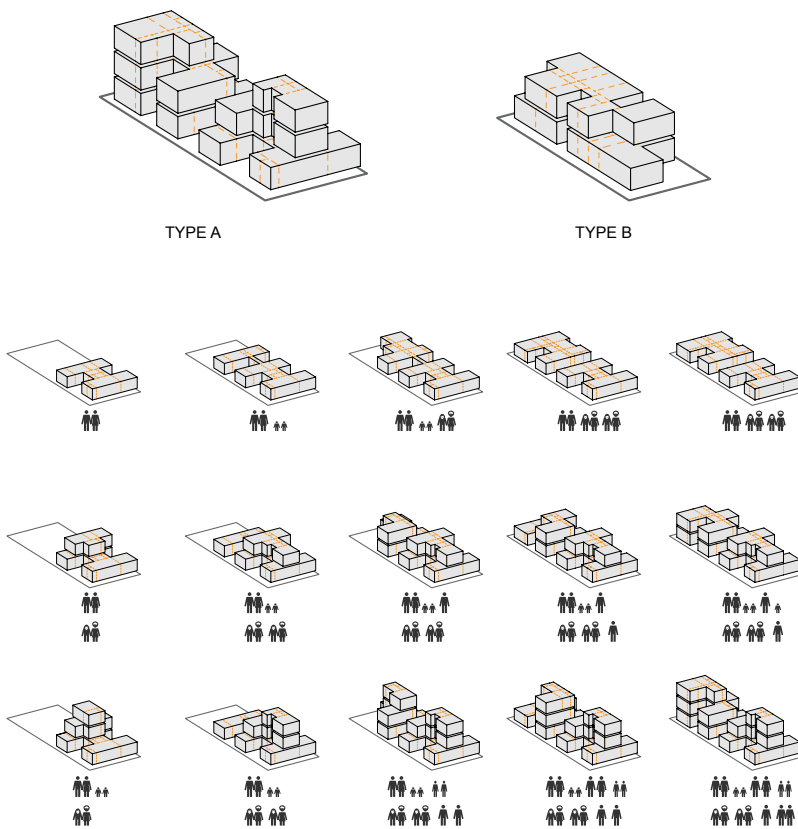

FIGURE 5.19: BASE DESIGNS AND PERMUTATIONS
 Each base design has different variations based on the number and type of occupants

where in the house the module would be located; choosing a base design will allow them to select the number of residents and the corresponding spatial requirements, then once the design is set, the users can view the modules in their selected design and make changes.

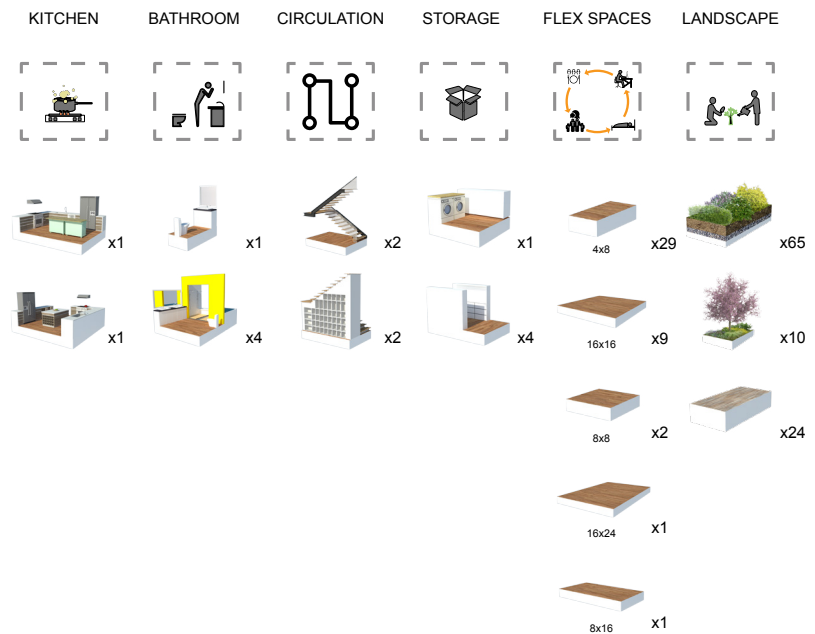
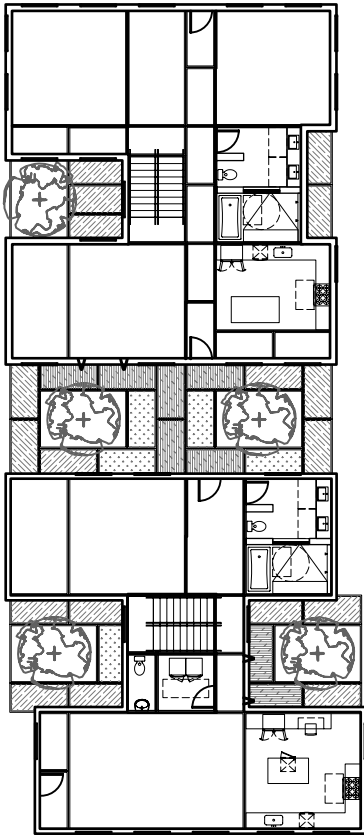

FIGURE 5.20: MODULE INCLUDED
 An example of the type and quantity of modules included in a base design.

L1



L2



L3

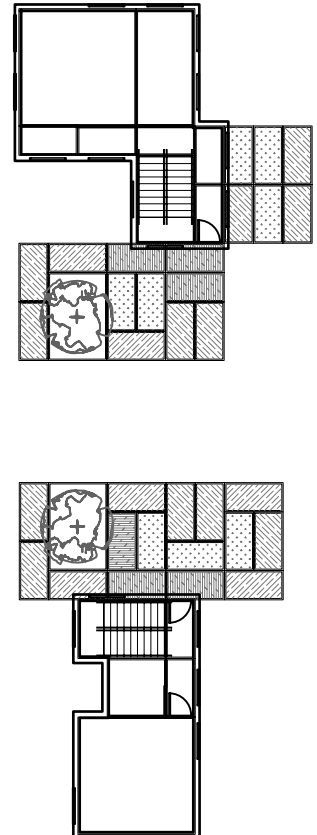

FIGURE 5.21: EXAMPLE FLOOR PLANS



FIGURE 5.22: INTERIOR RENDERINGS
Kitchen, bedroom, bathroom, hallway/storage.



FIGURE 5.23: INTERIOR RENDERINGS
Dining room, gardens.

5.6 Expansion and Contraction

Once ordered and built, families can choose to either expand or contract their spaces. As an example, a couple wishes to purchase a home. They go online and order a small house to fit their budget. A few years later, they have a baby and need a nursery. They order a flex space module and add it to their existing house. Shortly thereafter, their aging parents decide to move in to be closer to their grandchildren. The couple adds another flex space module and a bathroom module. Their child gets older and needs a larger room, so they get a larger flex space module to serve as a new bedroom, and an extra flex space module for a play area. Their parents pass away a few years later, so they sell off their old room. Then their child later graduates from college, and decides to take his module with him to start his own family.

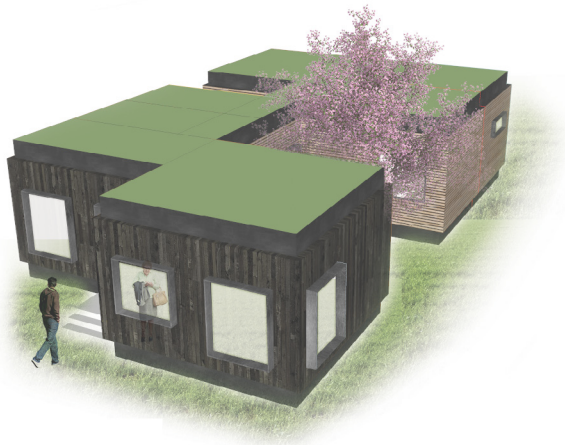

STARTER



1ST EXPANSION



2ND EXPANSION

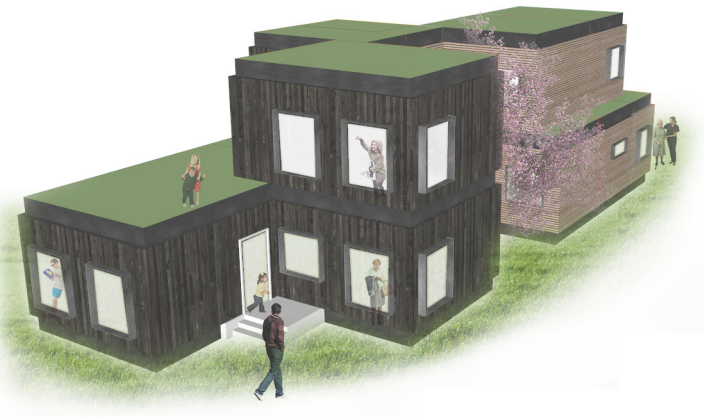

3RD EXPANSION

FIGURE 5.24: EXAMPLE OF EXPANSION

As a family's spatial requirements change, their housing should grow to accommodate that change.



FIGURE 5.25: MAP OF EXCHANGE

A map showing users willing to exchange modules.

5.7 Community Elements

When enough people use this typology, a market for the exchange of modules can develop. When in the process of expanding and contracting, owners can post what module they need or what module they no longer have the need for, and other members of the community can exchange with each other.

The website facilitates this community involvement by creating a database of people who have adopted this housing typology, and cataloging people who have expressed interest in exchanging modules. This data is made into map format, to illustrate proximity. Those who want to exchange and those who have the appropriate module are indicated on a block-by-block basis.

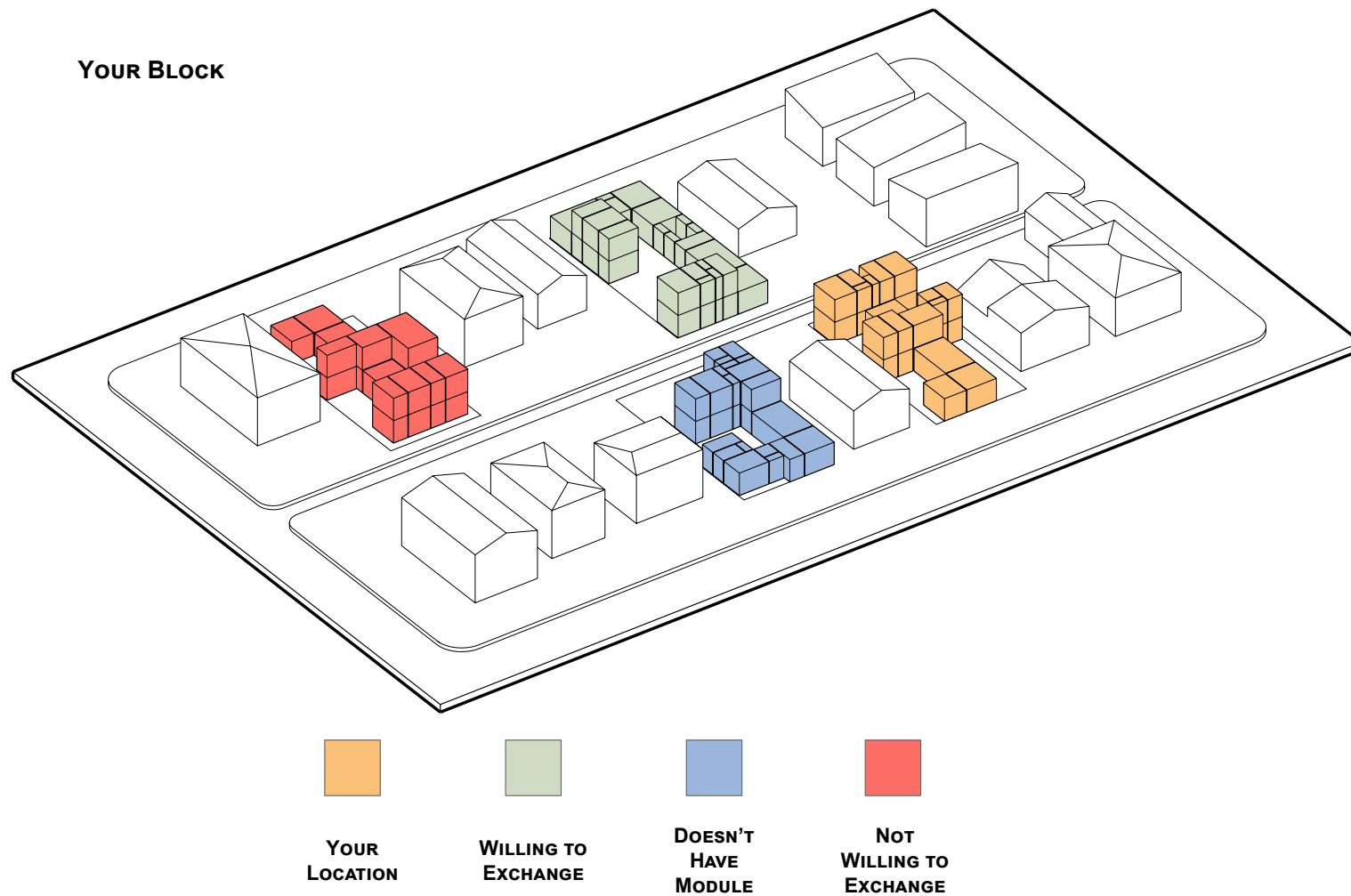
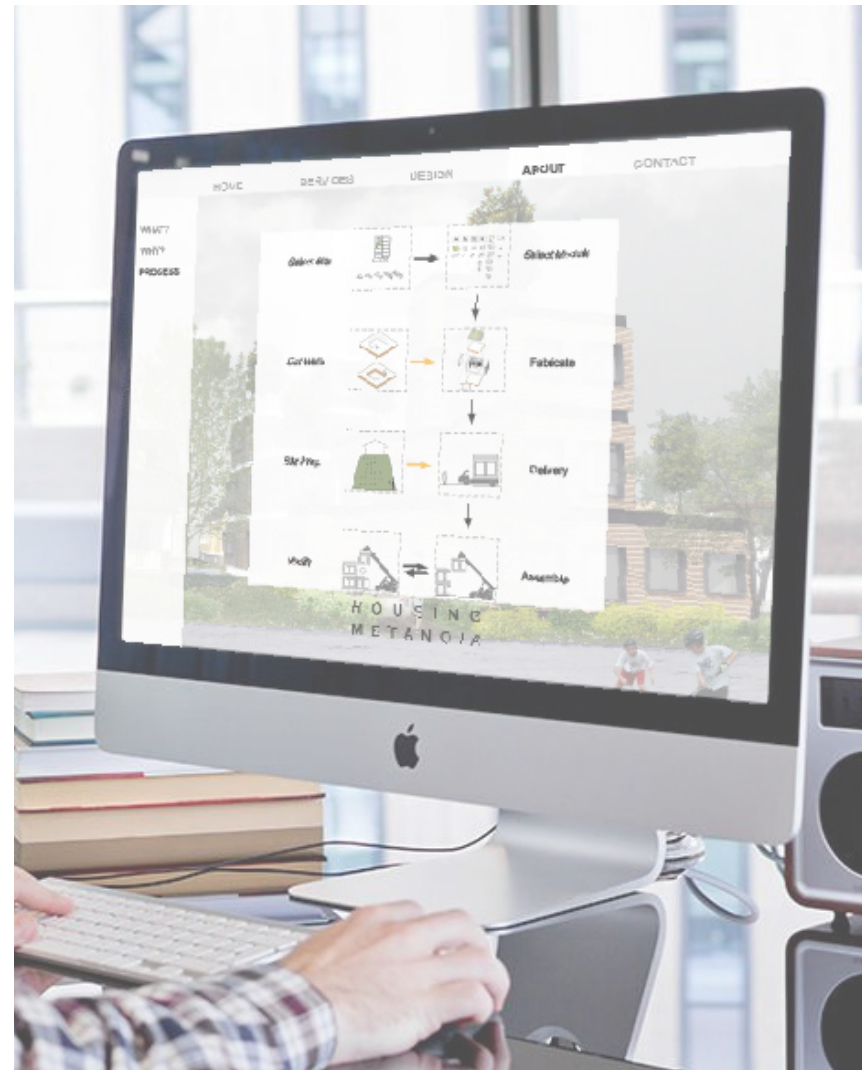
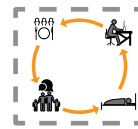

FIGURE 5.26: WHO'S ON YOUR BLOCK
 A block diagram showing people willing to exchange modules.



CHAPTER 6: Final Thoughts

CHOOSE MODULE



CHOOSE BASE DESIGN



CHOOSE WALLS

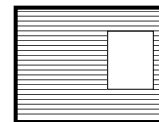

CONTACT DESIGNER



In Seattle, there is plenty of housing being developed. The downside is that the majority of it is studio and one bedroom apartments. While positive in the short run to house the tech boom happening right now, this development is horribly short-sighted and does not take into account what will happen in a few years when these newcomers start having families. Very little family-sized housing is coming out of this new development. Because of that, the existing family-sized housing stock is low and therefore too pricey for young and old families to afford on their own. This thesis began with a desire to bring families that are being driven out by lack of supply and affordability back into urban neighborhoods. Once that aspect was understood, the focus turned to how families evolve, and multi-generational living situations in particular. The conclusion derived from that exploration was that the current, static housing is unsustainable on economic,

cultural, social, and environmental levels. To solve this problem, housing must no longer be a static entity, but instead be flexible to adapt to changing ways of living. Thus, spatial flexibility and modularity quickly became the most important aspect of the design portion of this thesis.

As a prototypical housing typology, the goal is to be able to be implemented throughout the city in any single family lot, lack of site-specificity is to be expected. However, allowing for the owner to configure the prefabricated components as a kit of parts provides the its own context driven design.

The Housing Metanoia prototype provides relief to the current housing problem facing Seattle's middle-class families. Multi-generational households have the potential to increase density in single family neighborhoods while maintaining the similar character of single family homes. This allows the project to be more readily accepted by

Seattle's density-resistant urban neighborhoods. It becomes inherently cost effective when family members pool their resources together on things like housing cost, childcare and elder-care. It reduces the dependency on automobiles, since there is less need to travel to visit family and the family is in a public transit oriented urban neighborhood. Flexible design with the ability to expand and contract allows the owners to build as needed to fit their budget and spatial requirements. In addition, the website provides ease of access, configuration, order placement, and community engagement that would help families gain access to home-ownership.

In the final review, the jurors were excited by the concept of spatial flexibility, but expressed concern about how similar typologies such as Habitat failed to live up to the designer's expectations and in turn were not successful. They were also interested in the exchange infrastructure proposed, and how the idea could be expanded and how housing could become a part of the internet of things.

The prototype was successful despite concerns of weatherproofing, and the design provides a possible solution to the lack of family-sized housing in the city.

THIS PAGE IS LEFT INTENTIONALLY BLANK

List of Figures:

CHAPTER 1

- FIGURE 1.1: CHANGING SPATIAL REQUIREMENTS
- FIGURE 1.2: SPATIAL REQUIREMENTS: IDEAL VS ACTUAL
- FIGURE 1.3: MULTI-GENERATIONAL STATISTICS
Source: Pew Research Center, pewsocialtrends.org
- FIGURE 1.4: REASONS FOR MOVING
Source: United States Census Bureau, census.gov
- FIGURE 1.5: MULTI-GENERATIONAL STATISTICS
Source: Pew Research Center, pewsocialtrends.org
- FIGURE 1.6: MOVING BACK HOME
- FIGURE 1.7: EXISTING HOUSING MODEL
- FIGURE 1.8: FAMILY SIZED UNITS
- FIGURE 1.9: FAMILY SIZED UNITS
- FIGURE 1.10: IMPLICIT COST SAVINGS
- FIGURE 1.11: IMPLICIT ENVIRONMENTAL BENEFIT
- FIGURE 1.12: IMPLICIT SOCIAL BENEFIT
- FIGURE 1.13: MODULARITY AND FLEXIBILITY

CHAPTER 2

- FIGURE 2.1: SPATIAL REQUIREMENTS PER RESIDENT
- FIGURE 2.2: TYPES OF SPACES
- FIGURE 2.3: CURRENT WAYS OF HOUSING FLEXIBILITY
- FIGURE 2.4: HOW TO PROCEED

CHAPTER 3

- FIGURE 3.1: VARIABILITY
Source: Tatiana Bilbao, dezeen.com
- FIGURE 3.2: VARIABILITY
Source: Tatiana Bilbao, archdaily.com
- FIGURE 3.3: CORE + ADDITIONS
Source: Tatiana Bilbao, dezeen.com
- FIGURE 3.4: INCREMENTAL CONSTRUCTION
Source: Elemental, bdonline.co.uk
- FIGURE 3.5: SHOJI AND SPATIAL FLEXIBILITY
Source: Socks Studio, socks-studio.com
- FIGURE 3.6: TATAMI AND SPATIAL REQUIREMENTS
Source: Socks Studio, socks-studio.com
- FIGURE 3.7: CONNECTION TO NATURE
Source: Socks Studio, socks-studio.com

CHAPTER 4

- FIGURE 4.1: HOUSEHOLD SIZE IN SEATTLE
Source: Chad Newton, <https://buildthecity.wordpress.com>
- FIGURE 4.2: FAMILIES IN THE FRINGE
- FIGURE 4.3: ESTIMATED COST COMPARISON
- FIGURE 4.4: SINGLE FAMILY ZONES
- FIGURE 4.5: WALLINGFORD MAP
- FIGURE 4.6: WALLINGFORD PROXIMITY
- FIGURE 4.7: PROTOTYPICAL SINGLE FAMILY LOTS
- FIGURE 4.8: EXISTING VS PROPOSED ZONING
- FIGURE 4.9: FAMILY STRUCTURE AND USER GROUP
- FIGURE 4.10: PROGRAM TO MODULES
- FIGURE 4.11: DIMENSIONS OF MODULES
- FIGURE 4.12: PROGRAM SPACE PER RESIDENT

CHAPTER 5

- FIGURE 5.1: DESIGN CONSIDERATIONS
- FIGURE 5.2: CONCEPT FOR SPATIAL FLEXIBILITY
- FIGURE 5.3: FIXED STRUCTURE VS FLUID STRUCTURE
- FIGURE 5.4: MODULE TYPES
- FIGURE 5.5: MODULE VOLUMES
- FIGURE 5.6: KITCHEN MODULES
- FIGURE 5.7: BATHROOM MODULES
- FIGURE 5.8: STAIR MODULES
- FIGURE 5.9: STORAGE MODULES
- FIGURE 5.10: FLEX SPACE MODULES
- FIGURE 5.11: LANDSCAPE MODULES
- FIGURE 5.12: FABRICATION OF MODULE
- FIGURE 5.13: MODULE COMPONENTS
- FIGURE 5.14: STRUCTURAL ASSEMBLY
- FIGURE 5.15: MODULE TO MODULE ASSEMBLY
- FIGURE 5.16: SECTION PERSPECTIVE
- FIGURE 5.17: WALL TYPES AND MATERIALS
- FIGURE 5.18: WEBSITE
- FIGURE 5.18: PROCESS
- FIGURE 5.19: BASE DESIGNS AND PERMUTATIONS
- FIGURE 5.20: MODULE INCLUDED
- FIGURE 5.21: EXAMPLE FLOOR PLANS
- FIGURE 5.22: INTERIOR RENDERINGS
- FIGURE 5.23: INTERIOR RENDERINGS
- FIGURE 5.24: EXAMPLE OF EXPANSION
- FIGURE 5.25: MAP OF EXCHANGE
- FIGURE 5.26: WHO'S ON YOUR BLOCK

Works Cited

- “Family-Sized Housing: An Essential Ingredient to Attract and Retain Families with Children in Seattle.” Seattle Planning Commission, January 2014. Accessed April 10, 2016. http://www.seattle.gov/Documents/Departments/SeattlePlanningCommission/AffordableHousingAgenda/FamSizePC_dig_final1.pdf.
- “Rent Trend Data in Seattle, Washington.” Rent Jungle, 2016. Accessed April 10, 2016. <https://www.rentjungle.com/average-rent-in-seattle-rent-trends/>.
- “Student Debt Viewed as Major Problem; Financial Considerations Important Factor for Most Millennials When Considering Whether to Pursue College.” Harvard Institute of Politics, 2016. Accessed April 15, 2016. <http://iop.harvard.edu/student-debt-viewed-major-problem-financial-considerations-important-factor-most-millennials-when>.
- Alexander, Christopher. *A Pattern Language: Towns, Buildings, Construction*. New York: Oxford University Press, 1977.
- Bhatt, Sanjay. “Apartment Rents in King, Snohomish Counties Jump 5 Percent in 3 Months.” *The Seattle Times*, July 2, 2015. Accessed April 10, 2016. <http://www.seattletimes.com/business/real-estate/local-apartment-rents-up-almost-5-percent-in-3-months/>.
- Costello, Cavin. “3 Failings of Lennar’s NextGen Multigenerational Homes.” *Blooming Rock*, January 23, 2012. Accessed May 2, 2016. <http://bloomingrock.com/2012/01/23/3-failings-of-lennars-nextgen-multigenerational-homes/>.
- Engel, Heino. *The Measure and Construction of the Japanese House*. Tokyo: Tuttle, 1985.
- Fottrell, Quentin. “The Case for Living with Mom and Dad.” *Market Watch*, May 7, 2013. Accessed April 10, 2016. <http://www.marketwatch.com/story/the-case-for-living-with-mom-and-dad-2012-08-31>.
- Frearson, Amy. “Tatiana Bilbao Addresses ‘Urgent Need’ For Housing Mexico’s Poorest Inhabitants.” *Dezeen*, October 6, 2015. Accessed April 22, 2016. <http://www.dezeen.com/2015/10/06/tatiana-bilbao-low-cost-social-housing-mexico-chicago-architecture-biennial-2015/>.
- Fry, Richard and Jeffrey S Passel. “In Post-Recession Era, Young Adults Drive Continuing Rise in Multi-Generational Living.” *Pew Research Center*, July 17, 2014. Accessed April 22, 2016. www.pewsocialtrends.org/2014/07/17/in-post-recession-era-young-adults-drive-continuing-rise-in-multi-generational-living/.
- Kane, Libby and Andy Kiersz. “How Much You Have to Earn to Be Considered Middle Class in Every US State.” *Business Insider*, April 2, 2015. Accessed April 10, 2016. <http://www.businessinsider.com/middle-class-in-every-us-state-2015-4>.
- Kiersz, Andy. “Millennials Aren’t Making As Much As Their Parents Did When They Were Young.” *Business Insider*, December 5, 2014. Accessed April 10, 2016. <http://www.businessinsider.com/young-adult-vs-all-adult-weekly-earnings-2014-12>.
- Morath, Eric. “States Where Day Care Costs More than College.” *The Wall Street Journal*, April 11, 2016. Accessed April 25, 2016. blogs.wsj.com/economics/2016/04/11/states-where-day-care-costs-more-than-college/?mod=e2fb.

Morse, Edward Sylvester. *Japanese Homes and Their Surroundings*. New York: Dover Publications, 1961.

Otani, Takahiko. "Architectural Theoretical Examinations of Typical Japanese Spatial Characteristics in Interior Spaces of Kyo-Machiya Townhouses." *Archi-Cultural Translations through the Silk Road*, July 14-16, 2012. Accessed November 20, 2015. http://www.mukogawa-u.ac.jp/~iasu2012/pdf/iaSU2012_Proceedings_203.pdf.

Patton, Zach. "Seattle Looks to Cottages for Affordable Housing." *Governing*, May 2011. Accessed April 20, 2016. <http://www.governing.com/topics/economic-dev/seattle-looks-cottages-affordable-housing-options.html>.

Strange, Hugh. "Villa Verde Housing, Chile by Elemental." *BDOonline*, October 22, 2013. Accessed April 30, 2016. <http://www.bdonline.co.uk/villa-verde-housing-chile-by-elemental/5062384.article>.

Taylor, Paul, Jeffrey Passel, Richard Fry, Richard Morin, Wendy Wang, Gabriel Velasco, and Daniel Dockterman. "The Return of the Multi-Generational Family Household." *Pew Research Center*, March 18, 2010. Accessed April 22, 2016. <http://www.pewsocial-trends.org/files/2010/10/752-multi-generational-families.pdf>.