

Modeling & Analysis of Small Hydroelectric Generation and  
Battery Energy Storage Connected as a Microgrid

Kelly Kozdras

A thesis

submitted in partial fulfillment of the  
requirements for the degree of

Master of Science in Electrical Engineering

University of Washington

2016

Committee:

Daniel S. Kirschen

Baosen Zhang

Program authorized to offer degree:

Electrical Engineering

©Copyright 2016

Kelly Kozdras

University of Washington

**Abstract**

Modeling & Analysis of Small Hydroelectric Generation and  
Battery Energy Storage Connected as a Microgrid

Kelly Kozdras

Chair of the Supervisory Committee:  
Close Professor of Electrical Engineering, Dr. Daniel Kirschen  
Electrical Engineering

Interest in battery energy storage continues to grow as a way to realize a variety of benefits in complement to their ability to store energy, including incorporation in microgrids that can operate in parallel with or completely isolated from the larger power grid. This paper considers small hydroelectric generation and battery energy storage connected as a microgrid. The specific project studied is located in the mountains of Washington State, and the microgrid analyzed could provide backup power to a small town that experiences frequent power outages. A dynamic model is generated and a transient stability analysis of the system is performed to study whether it remains stable if operated as the proposed microgrid. In particular, the ability of the battery energy storage to provide frequency regulation to the generator is considered.

Acknowledgement:

The information, data, or work presented herein was funded in part by the Office of Energy Efficiency and Renewable Energy (EERE), U.S. Department of Energy, under Award Number DE-EE0002668 and the Hydro Research Foundation.

Disclaimer:

The information, data or work presented herein was funded in part by an agency of the United States Government. Neither the United States Government nor any agency thereof, nor any of their employees, makes and warranty, express or implied, or assumes and legal liability or responsibility for the accuracy, completeness, or usefulness of any information, apparatus, product, or process disclosed, or represents that its use would not infringe privately owned rights. Reference herein to any specific commercial product, process, or service by trade name, trademark, manufacturer, or otherwise does not necessarily constitute or imply its endorsement, recommendation or favoring by the United States Government or any agency thereof. The views and opinions of authors expressed herein do not necessarily state or reflect those of the United States Government or any agency thereof.

# Contents

- Table of Figures..... 6
- 1. Introduction..... 8
  - 1.1. Battery energy storage systems..... 8
  - 1.2. Small hydroelectric generation ..... 11
  - 1.3. Microgrids ..... 12
  - 1.4. Transient stability..... 14
- 2. Problem Description..... 16
  - 2.1. Puget Sound Energy project description..... 16
  - 2.2. Description of this project..... 18
- 3. Method ..... 20
  - 3.1. Modeling & analysis in PowerWorld..... 20
  - 3.2. Generator model..... 21
  - 3.3. Exciter model..... 23
  - 3.4. Governor model ..... 26
  - 3.5. Transmission & distribution model..... 28
  - 3.6. Battery energy storage system model ..... 28
- 4. Results..... 33
  - 4.1. Transient stability analysis without BESS..... 33
  - 4.2. BESS parameter tuning..... 38
  - 4.3. Transient stability studies with BESS..... 42
- 5. Conclusions and Future Work ..... 47
  - 5.1. Conclusions..... 47
  - 5.2. Future work ..... 49
- Appendix A..... 52
- Appendix B..... 54

# Table of Figures

Figure 1: Possible applications of energy storage systems [1] .....	8
Figure 2: Battery energy storage system schematic [1] .....	10
Figure 3: Example small-scale run-of-river hydroelectric system [5] .....	11
Figure 4: Example microgrid schematic [8] .....	13
Figure 5: Proposed microgrid in Glacier, WA.....	17
Figure 6: Map of proposed microgrid in Glacier, WA [17].....	18
Figure 7: GENSAL block diagram [20] .....	22
Figure 8: Power generation system block diagram [11].....	24
Figure 9: IEEE1A block diagram [20] .....	26
Figure 10: Pelton wheel high-head turbine [11].....	26
Figure 11: IEEEG1 block diagram [20].....	27
Figure 12: Simple BESS model [26] .....	29
Figure 13: REPC_A active power control block diagram [20] .....	31
Figure 14: Existing system with default exciter & governor settings ( $T_3 = 0.1$ s) .....	35
Figure 16: Existing system with default exciter settings & governor $T_3 = 0.25$ s.....	37
Figure 17: Generator speed with default exciter settings & governor $T_3 = 0.25$ s .....	37
Figure 18: Generator electrical power output with BESS $K_{pg} = 1$ .....	40
Figure 19: Generator rotor speed with BESS $K_{pg} = 1$ .....	40
Figure 20: BESS output with BESS $K_{pg} = 1$ .....	41
Figure 21: Summary of microgrid transient stability simulations .....	42
Figure 22: Generator electrical power output, 25% load increase (simulation 2) .....	44
Figure 23: Generator rotor speed, 25% load increase (simulation 2) .....	44
Figure 24: Load bus voltage, BESS internal voltage is 1.0 p.u. (simulation 2) .....	45
Figure 25: Load bus voltage, BESS internal voltage > 1.0 p.u. (simulation 3).....	45
Figure 26: Generator rotor speed, 0.5 MW base load (simulation 4) .....	46
Figure 27: Generator rotor speed, 1.5 MW base load (simulation 5) .....	46
Figure A1: REGC_A block diagram [20].....	52
Figure A2: REEC_C block diagram [28].....	53

Figure A3: REPC_A reactive power control block diagram [28] .....	53
Figure B1: Generator electrical power output with BESS $K_{pg} = 3$ .....	54
Figure B2: Generator rotor speed with BESS $K_{pg} = 3$ .....	54
Figure B3: BESS output power with BESS $K_{pg} = 3$ .....	55
Figure B4: BESS power, 25% load increase (simulation 2).....	55

# 1. Introduction

## 1.1. Battery energy storage systems

Large-scale energy storage has been implemented on the electric power grid as a method to store energy when power production is greater than consumption and release it when consumption exceeds generation capacity. Interest in battery energy storage continues to grow as a way to realize a variety of other benefits in complement to storing or discharging excess stored energy. These include greater and more efficient incorporation of intermittent renewable resources into the grid, an associated reduction in air emissions from generation, and an improved ability to employ transmission, distribution, and generation resources. A summary of many possible applications of energy storage systems is shown in Figure 1 below [1].

<b>Bulk Energy Services</b>		<b>Transmission Infrastructure Services</b>	
Electric Energy Time-Shift (Arbitrage)		Transmission Upgrade Deferral	
Electric Supply Capacity		Transmission Congestion Relief	
<b>Ancillary Services</b>		<b>Distribution Infrastructure Services</b>	
Regulation		Distribution Upgrade Deferral	
Spinning, Non-Spinning and Supplemental Reserves		Voltage Support	
Voltage Support		<b>Customer Energy Management Services</b>	
Black Start		Power Quality	
Other Related Uses		Power Reliability	
		Retail Electric Energy Time-Shift	
		Demand Charge Management	

**Figure 1: Possible applications of energy storage systems [1]**

Installation of battery energy storage systems (BESS) is being aided by grants and directives. The Washington Clean Energy Fund has provided funding to a variety of projects

including smart grid grants to utilities for incorporation of energy storage and improved information technology. This funding for energy storage has been and is being used to deploy battery assemblies to improve grid reliability and resilience at a variety of Washington state utilities, including with the project described in this paper [2]. In California, the Public Utilities Commission has passed a mandate that requires the state's largest three investor-owned utilities to add 1.3 GW of energy storage to their systems by 2020, which is the first mandate for energy storage in the United States. Large pumped storage facilities can't be counted towards this requirement, while other technologies like batteries and flywheels qualify [3].

A battery energy storage system consists of 2 main subsystems which include the storage and power conversion electronics as shown below in Figure 2. In addition, the system includes monitors and controls as well as switches and transformers that tie the system to the rest of the grid. Note that this is a schematic, and not necessarily representative of an energy storage system's physical configuration. The power conversion system is the interface between the battery and load and is bidirectional. It allows current to flow to the load and allows current flow in the opposite direction from the grid back to the battery to recharge it. The controls and power conversion system are generally designed to allow the BESS to perform many functions, such as some of the applications described above in Figure 1 [1]. A stability model of a BESS developed later in this paper will include these principal sub-components – storage, power conversion electronics, and a plant controller.

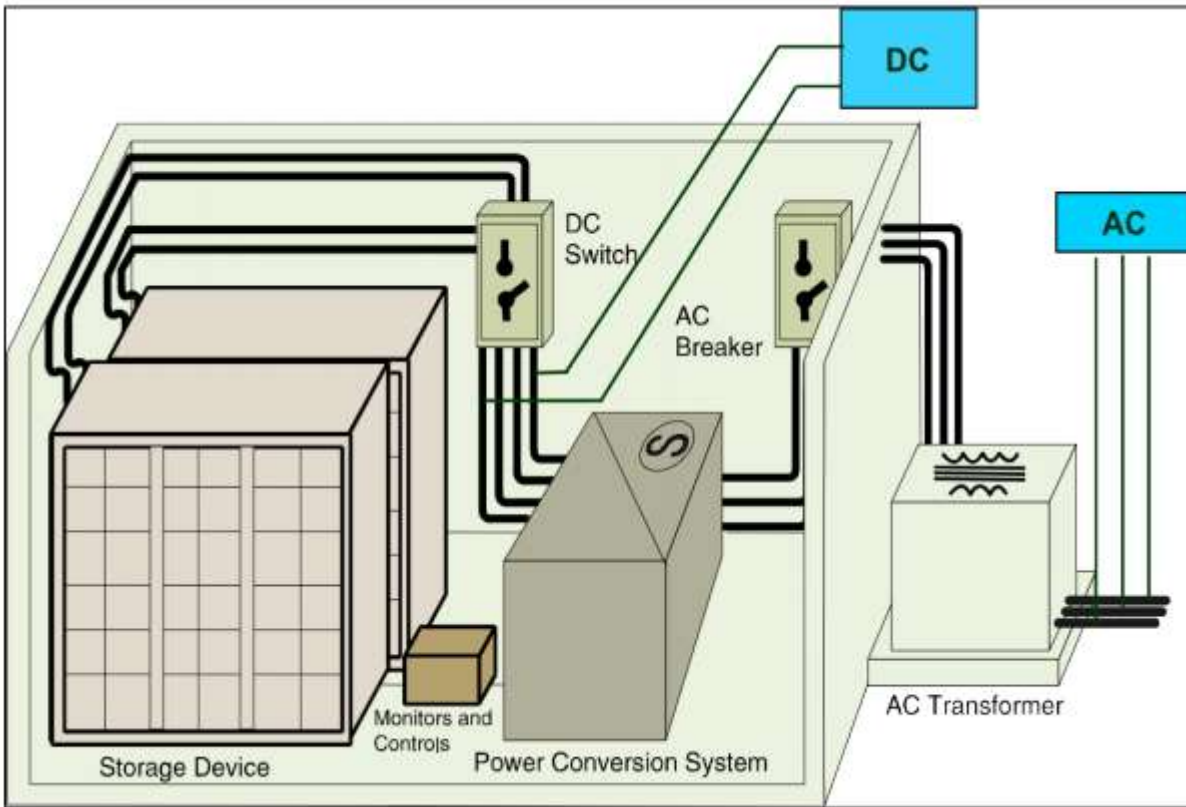

**Figure 2: Battery energy storage system schematic [1]**

A key aspect of integrating newer technology is the presence of relevant standards to increase the ease of implementing the project, permit it to readily interface with other system components, and allow for greater scalability. The Modular Energy Storage Architecture (MESA) Standards Alliance is developing two specifications with the involvement of a number of participants in the energy storage market. This includes electric utilities, storage and grid software companies, battery and inverter manufacturers, and a national laboratory. The MESA-ESS specifications will provide standards for communications and connection of the energy storage system to the utility SCADA and DMS. The project that will be discussed in this paper will utilize MESA standards, and the project owner (Puget Sound Energy) is a founding member of the standards alliance.

## 1.2. Small hydroelectric generation

Small hydroelectric generation sites are often “run-of-river” systems that rely on a change of elevation to generate electricity rather than requiring a large reservoir of water in front of the turbine (as is typical of larger hydroelectric generation). A small run-of-river system consist of a few key elements shown diagrammatically in Figure 3 below. Water enters the intake weir and goes through a settling basin that filters some of the larger sediment from the river. The water is then diverted through a channel to a forebay tank which regulates the fluctuation of the water, and allows for further settling of river sediment. The water then enters the penstock where it gains pressure through a change in elevation before entering a turbine in the power house. Run-of-river facilities are typically considered to have a smaller environmental impact as they do not rely on a dam to store water. There is therefore no need to flood an ecosystem that was once dry [4].

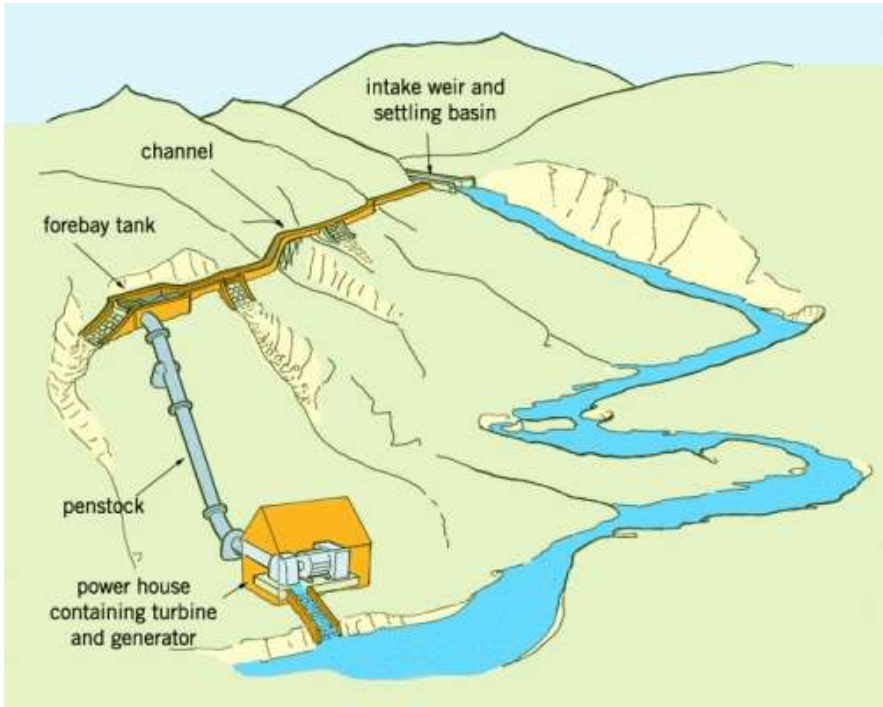
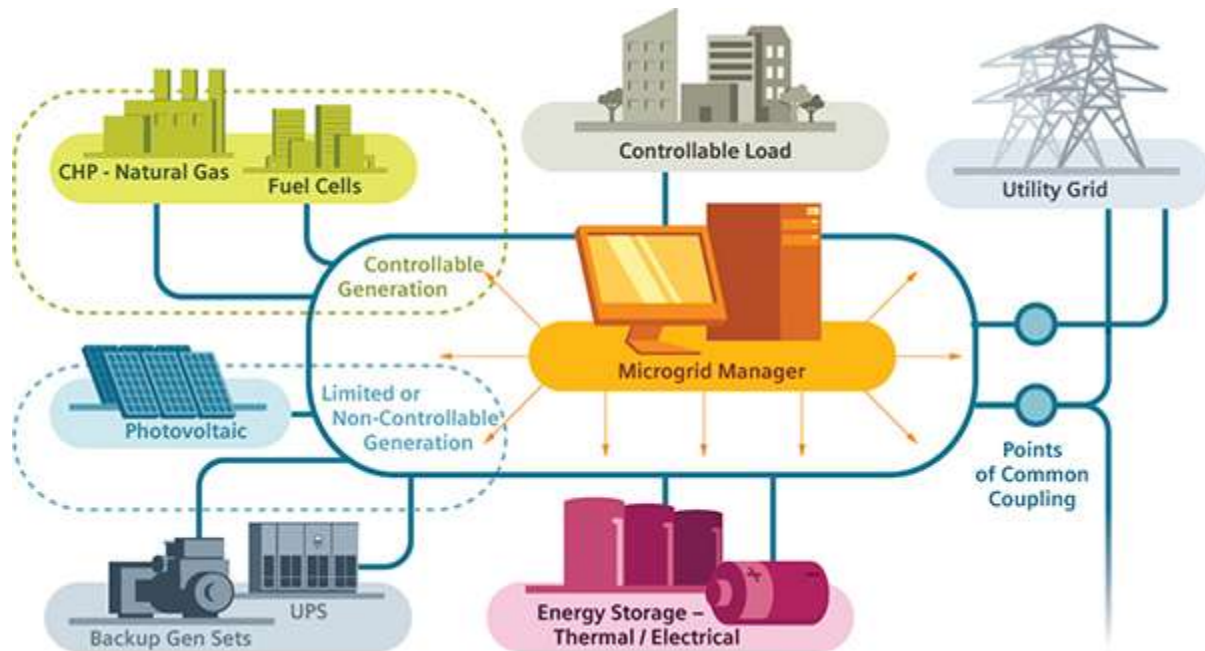

Figure 3: Example small-scale run-of-river hydroelectric system [5]

Renewable portfolio standards have been developed by many states as regulations that require prescribed increases in the generation of renewable resources over a particular period of time. Whether hydroelectric sources of any size can be counted towards these standards varies by state. For example, Oregon permits new small-scale hydroelectric projects of up to 50MW to qualify for their state's requirements if the project meet the requirements of the Low Impact Hydropower Institute. On the other hand, Washington State does not presently permit new small-scale hydroelectric projects to count towards their own state's standard, although legislators are considering a change to this [6].

### 1.3. Microgrids

A microgrid is a defined portion of a distribution system that can operate in parallel with or completely isolated from the larger power grid. Microgrids utilize regionally available smaller scale resources such as wind, solar, small hydro, biomass, and geothermal. A microgrid also incorporates some type of energy storage system to allow for continual service to the user, as well as a control systems to manage the system components. An example of a possible microgrid is shown below in Figure 4 and distinguishes the use of both controllable and non-controllable generation sources. Microgrids are currently being researched and developed in order to realize some of their benefits, which include increased resilience and incorporation of environmentally "friendly" sources. These advantages aid utilities in ways unique to their organization. For example, a utility may consider reliance on a microgrid for supply to critical loads during a blackout or for utilization during a natural disaster [7].



**Figure 4: Example microgrid schematic [8]**

As severe storms become more commonplace, the interest in microgrids has become broader. In 2012, Hurricane Sandy affected 8 countries including devastation throughout the eastern half of the United States. In the United States this included impact on 24 states, 157 fatalities, and greater than \$70 billion in damages. New York City, for example, experienced significant power outages across the city and throughout neighboring states as well as flooding in the streets, flooded vehicle and subway tunnels [9]. As a result of this, the New York State Energy Research and Development Authority (NYSERDA) developed the NY Prize microgrid competition. The competition awards funding to communities to plan, design, and construct microgrids across New York State. The first round of the competition resulted in 83 projects from towns around the state and neighborhoods in the city being awarded funding to prepare engineering feasibility assessments of their proposed projects. The program aims to both increase the resilience of the grid and promote integration of clean energy [10].

## 1.4. Transient stability

Transient stability as related to a power system refers to the system's ability to return to an acceptable stable operating point after a large disturbance. In this application a large disturbance includes faults and switching in or out of circuit elements such as generators, large amounts of load, and lines. A large disturbance triggers changes in the rotor angle of generators, generator departure from synchronous frequency, as well as changes in other system variables such as power flow and bus voltages. The dynamics that are considered in a transient stability study are on the order of a few milliseconds to a few seconds. Transient stability studies look at a selection of contingencies of interest for a particular system, and are performed to ensure the system remains stable for this selection of contingencies [11].

In a microgrid the low inertia and, in some cases, intermittency of sources create challenges with the control and stability of the system. Key factors that influence the stability of a microgrid include the control strategy and inertia of the generator, control strategy of any energy storage system, type of load including inertia of motor loads, and type of disturbance including location of any fault [12]. Controllers can be added to maintain stability. For example, in [13] the stability of a microgrid that contains small hydroelectric generation is maintained via incorporation of a speed controller and automatic voltage regulator into the system model. The control functionality of a BESS can also be utilized as an important element in maintaining microgrid stability, as described in this section 1.1 of this chapter. After a microgrid is isolated from the main grid it is connected to, the BESS can inject active power to stabilize the frequency and follow changes in the load [14]. This paper goes in depth about the stability factors related to the generator, energy storage system, and type of system

disturbance. In particular, this paper consider use of an energy storage system to improve transient stability when the system is operating as a microgrid with a small hydroelectric generator.

## 2. Problem Description

### 2.1. Puget Sound Energy project description

Puget Sound Energy (PSE) is a utility with headquarters in Bellevue, WA that provides electric and gas service to customers in many regions of western Washington State. PSE is implementing a battery energy storage system pilot project in Glacier, WA, a small town located in the North Cascade Mountains near Mt. Baker Ski Area. Glacier experiences power outages that are both somewhat frequent and lengthy (roughly 2.8 outages per year with a duration of 7.5 hours average). The primary cause of the outages is faults on a long 55 kV transmission line that serves the town of Glacier from the Kendall substation. This approximately 10-mile long line is shown in the upper left corner of Figure 5 below. The Kendall-Glacier transmission line extends through an area of heavy forest with few reasonable options for increasing the line's reliability. The substation in Glacier (also shown on figure below) serves over 1000 customers that are mostly residential but includes over 50 small businesses [15]. The town has approximately 250 year-round residents, and a peak in visitors during the winter ski season when storms are also more likely to cause power outages [16].

Given the reliability challenges in Glacier, PSE has recently installed and is testing a 2MW/4.4MWh battery energy storage system (also shown in figure below) that will allow for improved reliability. The BESS will also provide the ability to investigate other applications of utility-scale energy storage. Two of the applications that PSE has been interested in are relieving the system during peak consumption periods as well as increasing system flexibility [17].

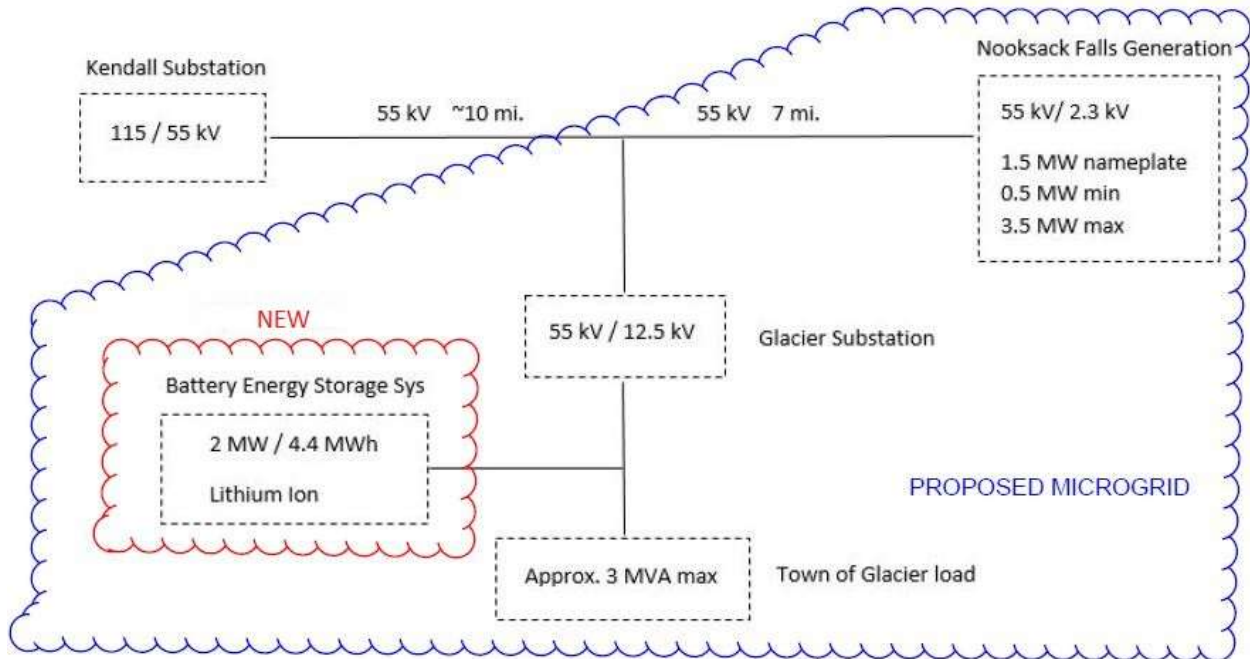
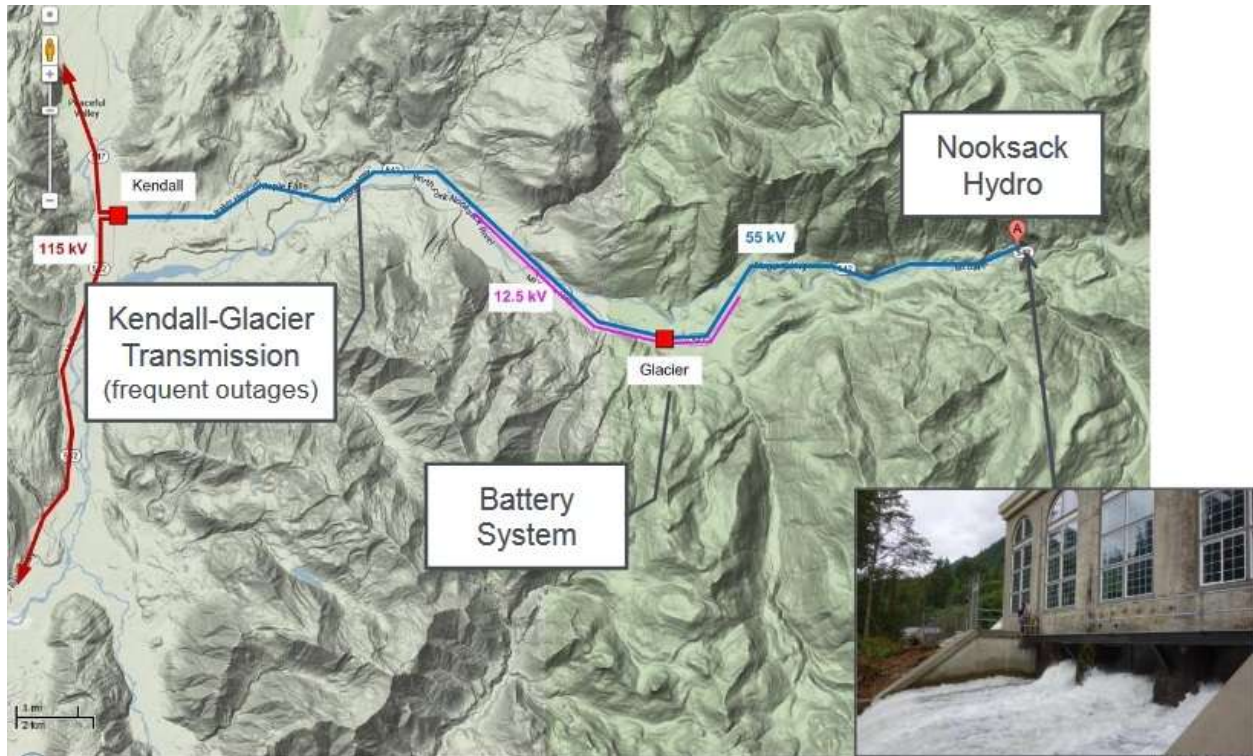

**Figure 5: Proposed microgrid in Glacier, WA**

This energy storage system is being considered for operation in “planned islanding” and “microgrid” mode. “Planned islanding” indicates use of the BESS to provide power to part or potentially all of the load in the town of Glacier during an outage. “Microgrid” indicates utilization (during an outage) of the BESS in parallel with Nooksack Falls Hydroelectric Power Plant, a small (nameplate 1.5 MW/2000 HP) hydro power plant less than 10 miles from the town of Glacier. All of these project elements are shown in Figure 5 and also pictured on a map in Figure 6 below.

Nooksack is a run-of river small hydro generation plant with a gross head of 226 ft. The site has a 5-foot diameter penstock which enters the powerhouse and goes into a Pelton turbine with six runners on one shaft [15]. It was originally constructed by Stone & Webster in 1906, which makes it the second oldest operating power generation facility in Western Washington. It was placed on the National Register of Historic places in December of 1988.

The plant operated until 1997 when a fire destroyed the generator. The site continued operations in 2003 after the replacement of the generator and other updates [18].



**Figure 6: Map of proposed microgrid in Glacier, WA [17]**

## 2.2. Description of this project

The project described in this paper includes a few key items. First, the project creates a dynamic model of a microgrid consisting of small hydroelectric generation and a battery energy storage system. Next it provides results of a transient stability analysis of the modeled microgrid. Finally, the project studies whether the BESS can provide frequency regulation to maintain the transient stability of the microgrid.

The particular project studied in order to achieve the goals described above is the “microgrid” aspect of the PSE project described in Section 2.1. Data was gathered about PSE’s existing and proposed systems to prepare a model of the microgrid in PowerWorld. This includes:

- Data about the existing transmission and distribution system in the area of Glacier, WA based on PSE’s own models.
- Drawings and data about the generator at Nooksack Falls and its governor and exciter from PSE engineers and the facility owner. This generator had not been modeled by PSE as its size does not require a model to be prepared (under WECC guidelines) [19].
- The proposed energy storage system design and procurement was done by a contractor to PSE, and coordination with them occurred to estimate the basic parameters of the battery model.

## 3. Method

### 3.1. Modeling & analysis in PowerWorld

A software program called PowerWorld was the tool used to generate a model of the microgrid system and perform a transient stability analysis of that system. PowerWorld is a power system simulation software that models network components in steady-state or in other conditions such as transient stability (of interest for this study). This chapter describes the basic PowerWorld model generated to simulate the microgrid at Glacier. Some elements that make up the proposed microgrid were already modeled by PSE, while the development of other aspects of the model is described here.

In order to perform a transient stability analysis in PowerWorld, a dynamic model of the system components was required. This model was generated by selecting block diagrams with transfer functions that best reflected the configuration of each individual system element. The system elements of the microgrid that were modeled with these block diagrams included the hydro generator at Nooksack, exciter, governor, and the BESS. PowerWorld contains dozens of potential block diagrams to select from for most categories of components [20]. Once a block diagram is selected that best models the particular component, various parameter values are calculated or chosen to further describe that dynamic model. Once these block diagrams and their parameters are completed, there are various types of transient contingencies available to simulate in PowerWorld. These contingencies include application of a fault or an increase or decrease in load at a selected point within the system.

### 3.2. Generator model

A variety of data was available from PSE and the generation site owner about the existing hydroelectric generation site at Nooksack Falls. A few pieces of information about this generator were most relevant to the selection of the appropriate block diagram and its parameters:

- The generator is salient pole [21]
- The generator nameplate rating is 1.5 MW, with a minimum generating turndown of 0.5 MW and a maximum generating output of 3.5 MW [16]
- Direct-axis reactances and time constants for the generator were provided by the generator manufacturer

Once this key information about the generator characteristics was gathered, an appropriate generator block diagram model could be selected from PowerWorld. Determining an appropriate block diagram to model a generator is simpler than selection of a block diagram for the system elements that will be discussed later in this section. The most commonly used generator models are GENSAL (a simple model for salient machines) and GENROU (a simple model for round rotor machines). Knowing that the generator at Nooksack Falls is salient pole indicated that the GENSAL model would be appropriate for this study. That block diagram for the GENSAL model is shown below in Figure 7.



could be obtained by reviewing typical parameter values from textbooks on power system dynamics and stability [11]. The inertia constant (H) was calculated based on the generator's moment of inertia (J), RPM, and MVA rating using the following formula with data provided by the generator manufacturer:

$$H = \frac{1}{2} \frac{J \left(2\pi \frac{RPM}{60}\right)^2 * 10^{-6}}{MVA \text{ rating}}$$

**Equation 1: Calculation of generator inertia constant [22]**

Once the inertia constant for the generator was calculated with these values, the inertia constant for the combined generator and turbine was estimated. In hydropower systems, the generator makes up most of the inertia. In this system, the generator was modelled as consisting of 95% of the combined generator and turbine inertia. Finally, the stator resistance, stator leakage reactance, and damping factor were estimated. These estimations were based on typical values provided for hydraulic generating units noted in another popular textbook on power system stability [22]. With the generator block diagram and its parameters selected, attention could be turned to other aspects of the dynamic model.

### 3.3. Exciter model

The roles of an exciter and governor in a power generation system are illustrated in the block diagram in Figure 8 below. A generator exciter provides a DC current that creates the magnetic field within the generator. Adjusting the magnetic field within the generator regulates the output voltage of the generator. The exciter is controlled by a voltage regulator which takes inputs from the measured voltage and current of the generator and compares

them to a reference voltage to provide an appropriate field current to the exciter. The governor references the measured power and frequency output of the generator and compares it with a previously established power-frequency curve. Discrepancies between the measured and preset power output and frequency are corrected by adjusting the turbine valve. This adjustment controls the amount of working fluid such as water, steam, or wind that enters the turbine, which ultimately controls the speed or power output of the generator.

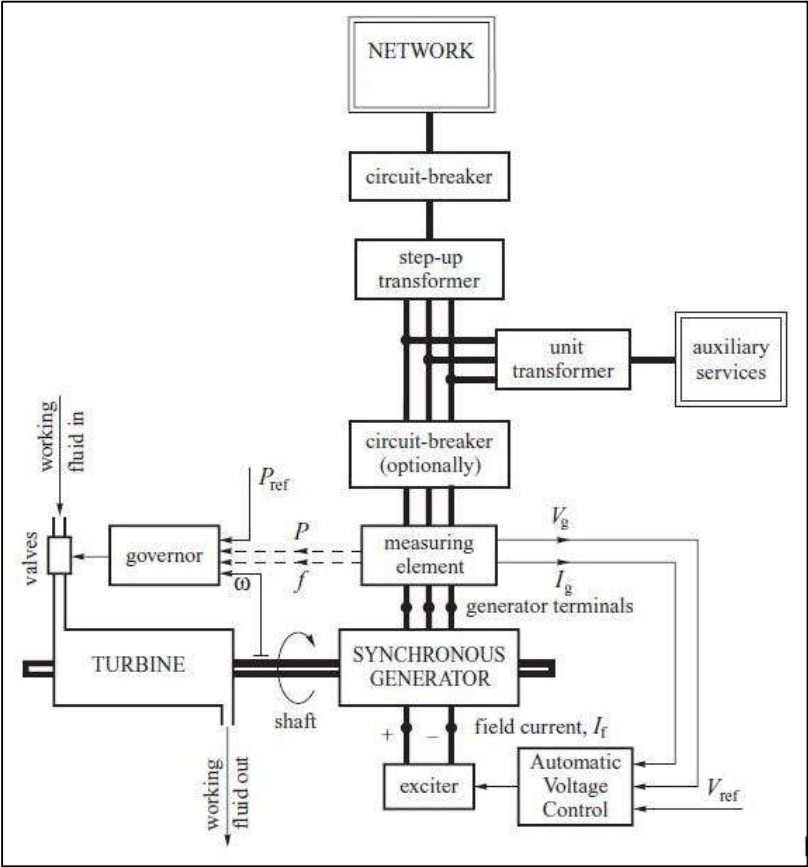

**Figure 8: Power generation system block diagram [11]**

The existing excitation and voltage control system at Nooksack Falls consists of a static exciter under manual control. This is achieved with an AC/DC converter, potentiometer, and power switch. The AC/DC converter takes AC line current and transforms it to a DC current to supply the generator with the DC field current. The AC/DC converter uses silicon-controlled

rectifiers (SCR) arranged in a bridge circuit. A power switch pulls in a contactor that provides power to this rectifier, or alternately drops the rectifier (and thus the generation capability at Nooksack Falls) after a system trip. A potentiometer that the site operator manually operates provides a variable signal to the rectifier's trigger card to control the rectifier's output [23].

As was the case with the model of the generator, there are dozens of block diagrams available to describe the dynamics of the exciter system. However, unlike the case of the generator, there are not just a few exciter block diagrams that are typically used for their modeling. Given the breadth of options, an appropriate exciter model was selected based on the following standards:

- The simplicity of the block diagram to mimic the simplicity of the device being modeled.
- Preference for any of the IEEE exciter block diagrams. These are standardized models to represent a variety of exciter systems presently in use. A benefit of these models is that a reasonable amount of documentation exists to describe both the models and their parameters [24].
- Recommendation of technical support engineers at PowerWorld with experience in which exciter models work well with the GENSAL generator model being used [25].

Based on these preferred qualities for a block diagram to model the exciter system, the IEEE T1A or Modified IEEE Type 1 Excitation System was chosen and is shown below in Figure 9. The values for the model parameters consisted mostly the model default parameters.

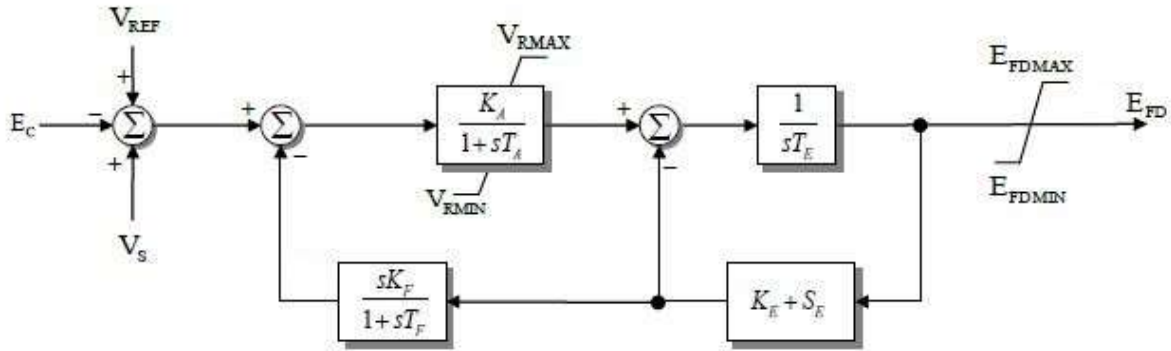

Figure 9: IEEE1A block diagram [20]

### 3.4. Governor model

The governor at Nooksack Falls is hydraulic operated with control of the turbine needles by a PLC. In a Pelton turbine, such as what is installed at Nooksack, the power output of the turbine is controlled by a needle in a nozzle that regulates the incoming water as shown in Figure 10. Water from a high-head source (such as is seen in the image on the right-hand-side of the figure) enters through a nozzle. This entry point is shown by the arrow in the center of the figure. High pressure water streams from the nozzles onto the bowl-shaped buckets that rotate the turbine runner. The power output of the turbine is determined by the size of the water stream, which is controlled by a needle in the nozzle.

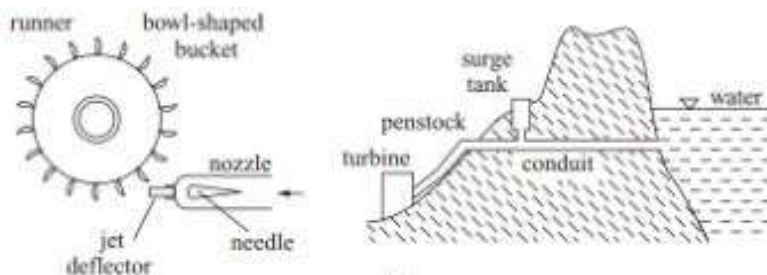

Figure 10: Pelton wheel high-head turbine [11]

Similar to the generator and exciter models, there are many block diagrams available to describe the dynamics of the governor system. An appropriate model for the governor system was selected based on the same criteria as described in Section 3.3 regarding the selection of the exciter block diagram. That is, the model should be simple to mimic the simplicity of the Nooksack Falls governor, preference is given to IEEE block diagrams, and finally the input of technical staff at PowerWorld was solicited to provide a recommendation on a governor block diagram that works well with the GENSAL generator model. Given this criteria, the IEEE G1 or IEEE Type 1 Speed-Governor model was selected and is shown in Figure 11 below [25]. The values for the model parameters used for this system were the model default parameters with the exception of  $T_3$ , the valve positioner time constant. The selection of that time constant is described with the results in Section 4. Note that in the default parameters, gain  $K_1$  has a value of one, but gains  $K_3$  through  $K_8$  as well as time constants  $T_5$  through  $T_7$  have values of zero thus vastly simplifying the block diagram below. With the completion of the block diagrams for the generator, governor, and exciter, the attention could be turned to aspects of the microgrid other than the existing generation.

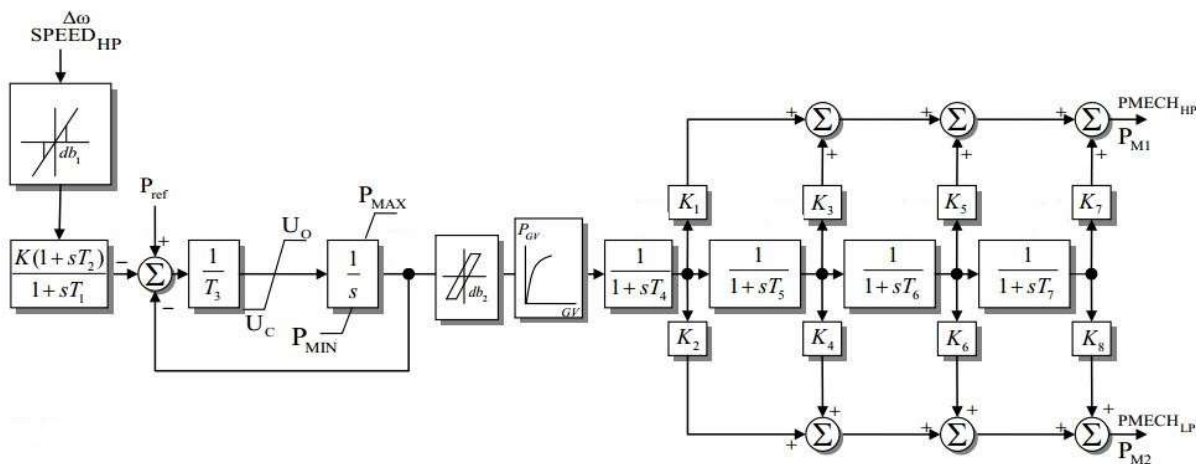

Figure 11: IEEE G1 block diagram [20]

### 3.5. Transmission & distribution model

The transmission and distribution networks in the area of Glacier are the other pieces of the existing system that required modeling for the microgrid. The power flow data for the 55 kV transmission lines and load at Glacier was from PSE's 2015-16 winter base planning case. For the distribution system in the area of Glacier, some minimal detail of the existing transformers was available and incorporated into the PowerWorld model. Data about the average, maximum, and minimum load for Glacier was also available. This data becomes helpful when various transient contingencies are analyzed.

In order to model the 55 kV transmission and 12.5 kV distribution lines in PowerWorld, the line resistance and reactance are incorporated in the model. Additionally, transformer ratings are entered as appropriate. The load at Glacier is modeled as a constant power load. If further details become available about the distribution lines and transformers and the location of loads within that topology, that information could be incorporated into a power systems simulation tool to increase the accuracy of the distribution system model. PowerWorld does not presently allow for unbalanced 3-phase loads that are typical of a distribution system, and so another simulation tool would be required.

### 3.6. Battery energy storage system model

The BESS installed at Glacier was designed by a contractor to PSE. The system consists of a 2 MW / 4.4 MWh lithium-ion batteries and a power conversion system that will provide voltage and frequency regulation when the Glacier system is islanded and the BESS is operating [15]. The Electric Power Research Institute (EPRI) has worked with partners in industry to

develop generic stability models that can be used for renewable energy resources such as wind and photovoltaic generation and more recently for BESS modeling. The BESS is represented by three separate models that are shown below in Figure 12. These three models work together to describe the transient behavior of a BESS.

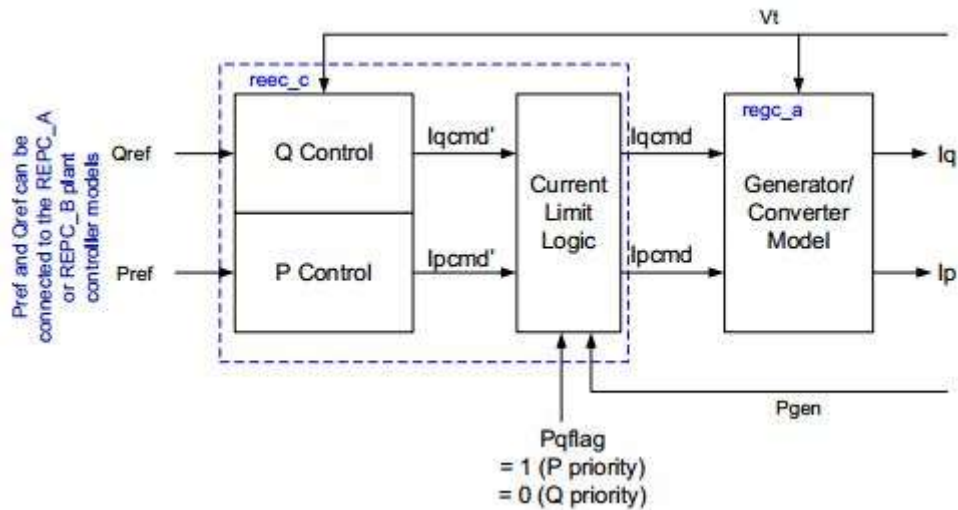

**Figure 12: Simple BESS model [26]**

The three block diagrams that make-up a BESS model are noted in Figure 12 in blue and are **regc\_a**, **reec\_c**, and **repc\_a**. Model **regc\_a** represents a generator or converter model, and in the case of the BESS is the inverter interface. It is controlled by real and reactive current commands and injects real and reactive current into the grid model with which it is connected. Model **reec\_c** is the electrical control module and in the BESS models the inverter controls and battery charging and discharging. It takes inputs of real and reactive power and provides the real and reactive current commands that control module **regc\_a**. Model **repc\_a**, representing a plant controller model, is the final model in the BESS system. This model is not required but when implemented takes values from the network solution and produces real and reactive power references that can be utilized for voltage and frequency control of other devices in a

plant [26]. The repc\_a model was incorporated into the Glacier microgrid simulation to test the possibility of providing frequency control to Nooksack Falls when the system is isolated as a microgrid, and will be further discussed later in this section.

Some basic design parameters about the BESS were available from the contractor that designed the system. The real and reactive power limits which apply to all three of the BESS models were the available parameters that were incorporated into the simulation. Estimation and experimentation was required for all other model parameters. The detailed block diagrams for models regc\_a and reec\_c are shown in Appendix A and were modeled with PowerWorld's default parameters.

The detailed model of repc\_a can be seen below in Figure 13 and is the model where most of the experimentation in PowerWorld was done during this project. Note that this figure shows the active power control block diagram of the plant controller, while the reactive power control block diagram is shown in Figure A3 of Appendix A. The possibility of maintaining stability on the microgrid system with assistance of the BESS is appealing given the limited control capabilities that presently exist at Nooksack Falls. The plant controller repc\_a was used to test the possibility of providing frequency control to the microgrid. EPRI guides for using the repc\_a block caution that this model is considered not fully validated or tested, and care should be taken in selecting parameters [26]. Given this, the variations to the repc\_a parameters were done to determine if any values for the parameters existed that could provide adequate frequency control to maintain the stability of the microgrid. That is, the parameters were not based on the design of the installed BESS. Despite the lack of a connection to the designed BESS, these simulations are still useful given the very limited documentation that exists about

the transient stability of microgrids containing hydroelectric generation. This lack of references for this type of microgrid is especially notable given the greater availability of information about microgrids containing other resources such as wind or solar.

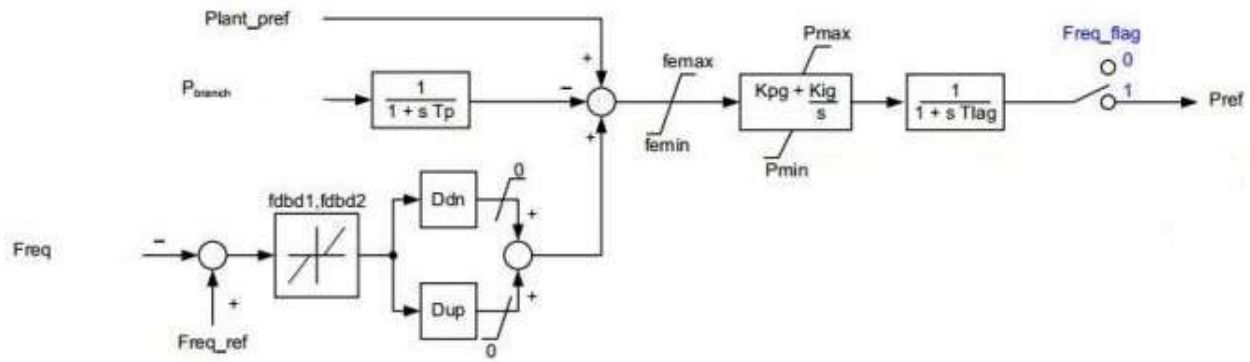

**Figure 13: REPC\_A active power control block diagram [20]**

The variations to the BESS parameters were restricted to stay within the reasonable limits noted in the EPRI document [27]. In addition, the parameter `Freq_flag` was set to 1 to activate the frequency regulation control loop. Figures that show results of interest based on varying these parameters are discussed and shown in Section 4. The following parameters (shown in Figure 13) were varied in the `repc_a` model to find settings that maintained the microgrid system stability:

- $T_p$ : Lag time constant on  $P_{gen}$  measurements.
- $fdbc1, fdbc2$ : Downside and upside deadband.
- $D_{dn}, D_{up}$ : Downside and upside droop. Variation of these parameters have an effect on the plant controller's ability to maintain microgrid stability.
- $femax, femin$ : Maximum and minimum error limit.

- $K_{pg}, K_{ig}$ : Proportional and integral gain control. Variation of these parameters had great impact on the plant controller's ability to maintain microgrid stability as will be shown in the results.
- $T_{lag}$ : Lag time constant on Pref feedback.

## 4. Results

### 4.1. Transient stability analysis without BESS

With all block diagrams inserted into the model and parameters selected by the methods discussed in chapter 3, the performance of the system during transient contingencies can be studied. There are several options for applying transient contingencies to a PowerWorld model. These include actions such as applying a fault, adding or removing the element from the model, or changing an element's associated values. These actions can be applied to system elements such as buses, lines, breakers, loads, generators, and transformers.

The first stability analyses performed consisted of modeling the generation (including governor and exciter) at Nooksack Falls as well as the 55 kV transmission and 12.5 kV distribution in the area of Glacier. The BESS is not included in this initial transient stability analysis, as the goal was to see how the system that already exists at Glacier and Nooksack performs when isolated from the rest of the grid. The first task when studying the transient response of this system without the BESS was to confirm that the performance of the transient models for each system element is reasonable considering the actual system. While manufacturer's data was available about the generator that was used in the dynamic model, recall that similar information was not available for the exciter or governor. The exciter, for example, was custom built and so recommendations for a stability model for it could not be obtained from a manufacturer. Variations to the governor and exciter parameters were done with the goal that the system (without the BESS) would maintain stability in the event of a small load increase. Given the lack of manufacturer data about the exciter and governor, the parameters were selected to meet this goal (while still being adequately physically realistic) and

should not be considered as a precise model of the installed exciter and governor. A more precise model could be generated by testing the installed generation system and obtaining characteristic curves of that system.

The first of the existing system cases that was simulated was with the exciter and governor at their default PowerWorld parameter settings. This serves as a baseline for considering what tuning of the parameters could be useful. The sequence of events in the simulation are noted below. It may be helpful to reference the diagram in Figure 5 to review the layout of the system:

- 0 seconds: Initialize simulation with BESS and Nooksack connected to Kendall and infinite bus with 1 MW load in Glacier.
- 20 seconds: Open line at Kendall (isolating BESS and Nooksack from infinite bus).
- 40 seconds: Increase load in Glacier by 10%.

As can be seen in Figure 14, the generator electrical power oscillates before returning to its new steady state value. Similar instances of oscillations before returning to steady-state were observed for the generator's rotor speed, mechanical power, and bus voltage. These outputs reflect the type of response that is desired for a generator to maintain stability in the midst of changing system conditions. However, the oscillations in this simulation occur faster than is likely to occur in a hydroelectric generator given that the medium being controlled is flowing water. This indicates that the model parameters require adjustment.

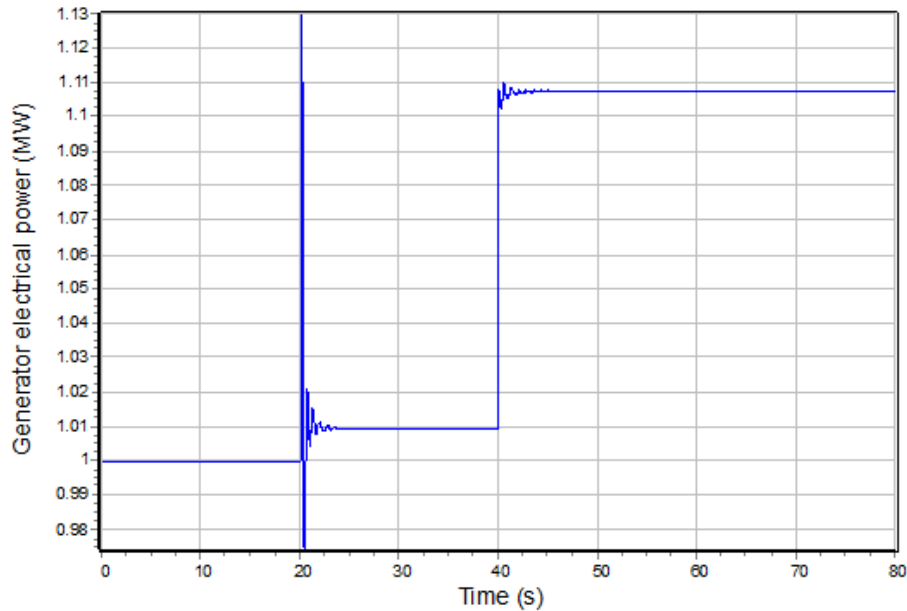

**Figure 14: Existing system with default exciter & governor settings ( $T_3 = 0.1$  s)**

The adjustments to the model focused on the governor as those adjustments directly impact the rotor speed and power output oscillations. A few of the governor model parameters were varied, but the parameter  $K$  (gain) and  $T_3$  (valve positioner time constant) were primarily reviewed. The gain,  $K$ , is the reciprocal of the governor droop. The speed-droop coefficient, or droop, indicates how much the generator speed will slow down (speed up) for a given increase (decrease) in load. A typical value for droop is between 4 – 9%, a gain of roughly 11 – 25, with PowerWorld’s default gain set at 25 (4% droop) [11]. With confirmation that the default PowerWorld gain is within reasonable limits, the focus turned to parameter  $T_3$ .

Variation of the parameter  $T_3$  had the most desired impact on the simulation outputs. First the value of parameter  $T_3$  was increased from the default of 0.1 seconds to 1 second. The results of this are shown in Figure 15. Recall that the goal of the modifications to the model were to maintain stability for a small load increase but with oscillations that were less rapid. Increasing  $T_3$  to 1 second did succeed in making the oscillations less rapid but does not

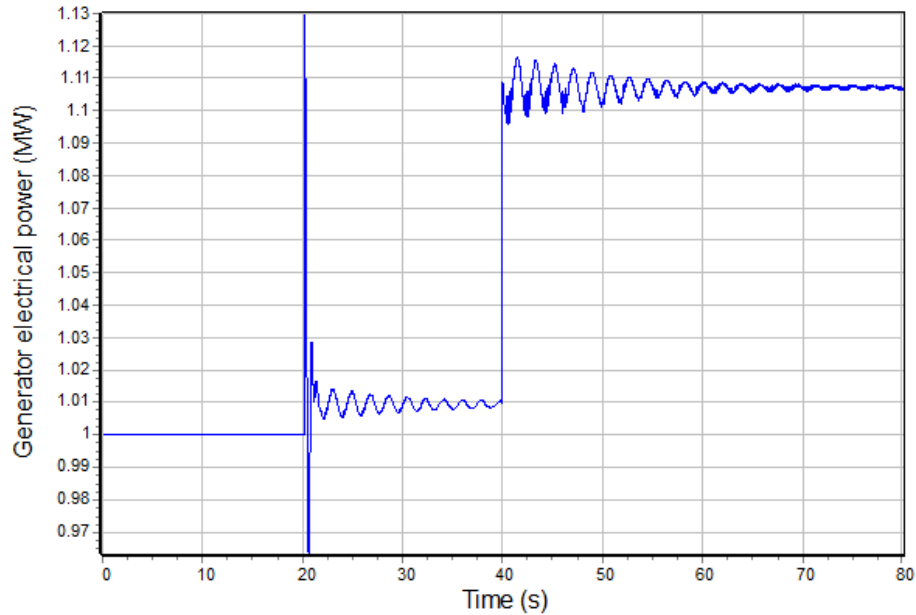

**Figure 15: Existing system with default exciter settings & governor  $T_3 = 1$  s**

maintain stability. The generator speed and mechanical power had even larger amplitude oscillations than those in this plot of generator electrical power. Parameter  $T_3$  was then varied between these two values and a good middle ground between them was found with  $T_3$  at 0.25 seconds. The results are shown in Figure 16 and 17 which are more realistic generator oscillations that still remain stable. The parameter of  $T_3$  was set at this value of 0.25 seconds.

With any simulation, it is useful to review several system outputs to confirm that the system is behavior is as expected. For example, recall that as a generator's power output is increased, the speed of the generator decreases. The rotor speed during this simulation is shown in Figure 17 and reflects this expectation. When the load is increased at 40 seconds, the generator electrical power increases while the rotor speed decreases. The generator mechanical power is not shown here but increases from 1 MW to 1.1 MW to match the electrical power, as would be expected by a system that is stable.

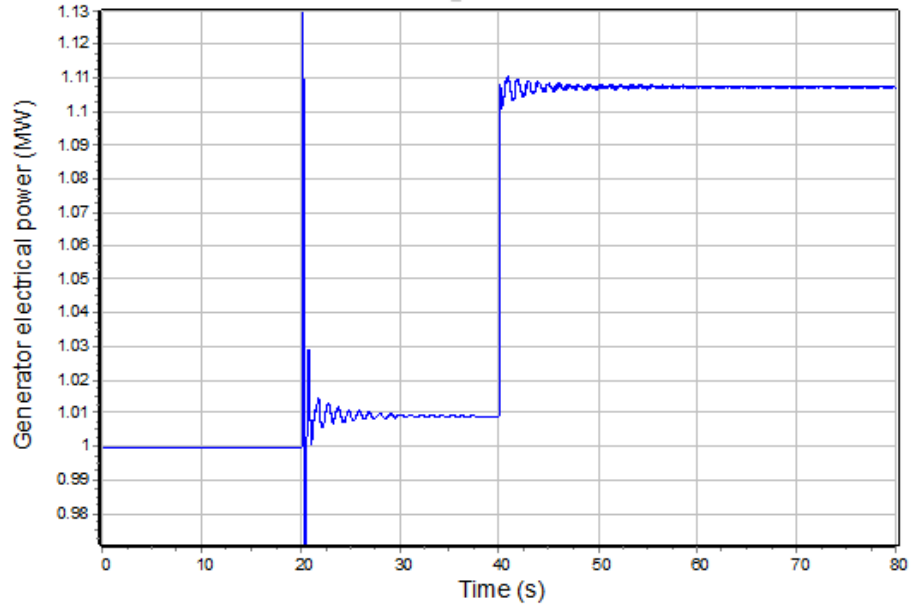

**Figure 16: Existing system with default exciter settings & governor  $T_3 = 0.25$  s**

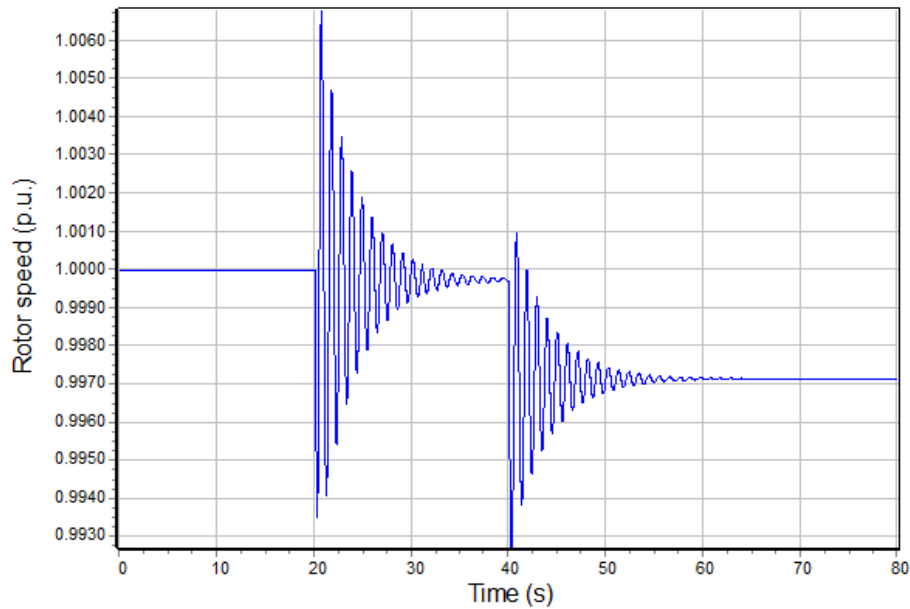

**Figure 17: Generator speed with default exciter settings & governor  $T_3 = 0.25$  s**

One final test of the existing system without the BESS was performed to review the model's performance. Transient stability is calculated by differential equations derived from Newton's second law of motion that describe the motion of a generator's rotor. The second-

order model of the solution (referred to as the swing equation) can also be written as two first-order equations by the following:

$$M \frac{d\Delta\omega}{dt} = P_{acc}$$
$$\frac{d\delta}{dt} = \Delta\omega$$

**Equation 2: Swing equation in first-order format [11]**

In these equations M is the generator inertia coefficient,  $\omega$  is the generator speed,  $P_{acc}$  is the net accelerating power, and  $\delta$  is the rotor angle. All of the time varying quantities ( $\omega$ ,  $P_{acc}$ , and  $\delta$ ) are values that can be plotted in a PowerWorld simulation. A simulation was done with the Nooksack generator isolated from the grid after the line opens at Kendall. The governor and exciter were not incorporated in this simulation to consider the action of the generator only and not its control. An approximation of the changes in the time varying quantities was noted from the output plots, and each part of equation 2 calculated. These calculations resulted in the solutions for the left side of each equation being reasonably close to the solution to the right side of the equation. This version of the swing equation is simplified, so given that the solutions were in the same order of magnitude is a helpful verification of the model's performance.

## 4.2. BESS parameter tuning

With governor parameters that have been tuned, the second stability analyses were performed. These consisted of simulating the generation at Nooksack Falls, transmission and distribution in the area of Glacier, and the BESS with the same series of transient contingencies

described in section 4.1. This case was first simulated with PowerWorld default parameters for the BESS. This resulted in instability in the form of large and increasing amplitude oscillations in the measured quantities like generator rotor speed, electrical power, and bus voltage. The parameters were then varied within the reasonable limits noted in the EPRI document [27], as described in section 3.6. Many of the model parameters shown in Figure 13 were varied with just a few having significant impacts on the system stability. While the upside and downside droop ( $D_{up}$ ,  $D_{down}$ ) did have notable effects on the simulation results, the proportional and integral gain ( $K_{pg}$ ,  $K_{ig}$ ) were a key to ensure the microgrid's stability. This stability was achieved by reducing the integral gain to zero, and keeping the proportional gain low. Proportional-integral control is the most common combination among the modes of control that include proportional, integral, and derivative control. However, tuning the integral control is also more complex and sensitive than only tuning the proportional control [29]. These simulations only varied the proportional gain and eliminated the integral control, but an interesting investigation would be raising the integral gain greater than zero. A range of values were considered for the proportional gain. The value for  $K_{pg}$  that was settled on was 1 and Figures 18 and 19 show results at this setting. For comparison, review Appendix B and Figures B1 through B3 which includes plots at  $K_{pg}$  of 3. The system becomes less stable as the value for  $K_{pg}$  increases, and is unstable when  $K_{pg}$  is set to 3 making it an undesirable value for that setting.

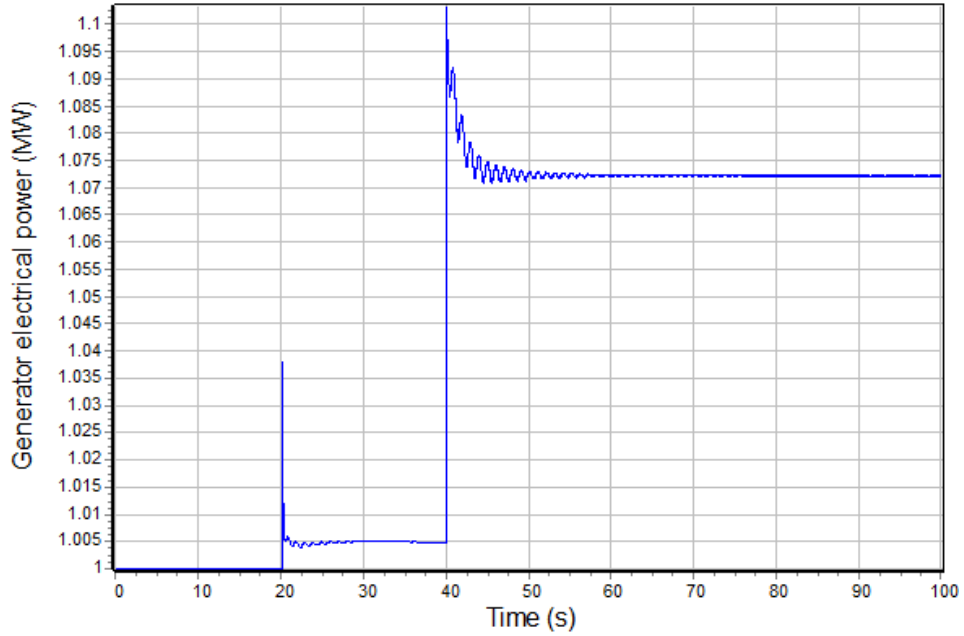

**Figure 18: Generator electrical power output with BESS  $K_{pg} = 1$**

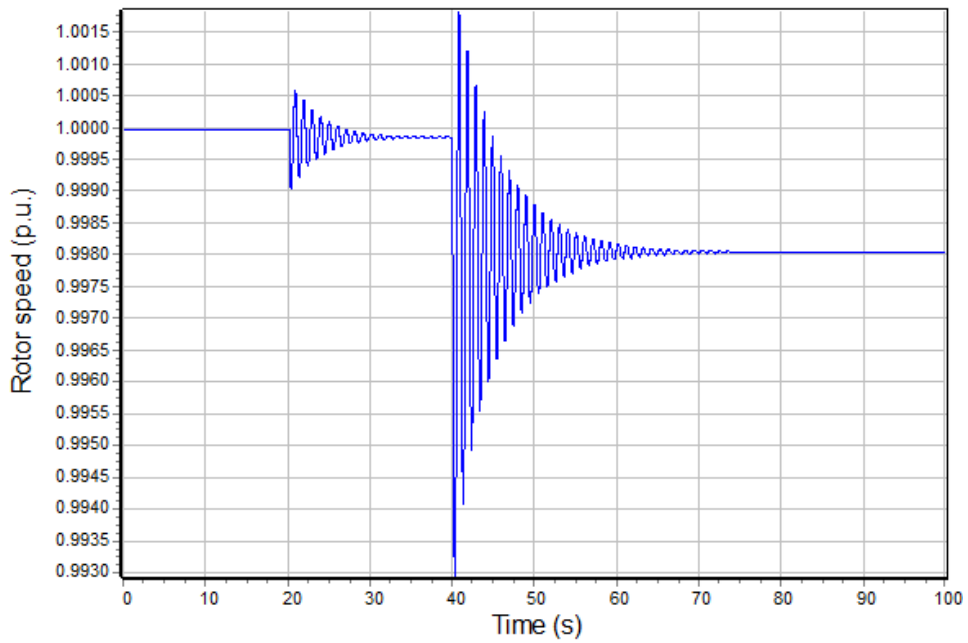

**Figure 19: Generator rotor speed with BESS  $K_{pg} = 1$**

Once the BESS parameters are tuned, it is necessary to consider whether simulation outputs make physical sense (as done after tuning the governor parameters). It is interesting to review the output of the BESS shown in Figure 20 and compare what is occurring in that figure

with the electrical power output of the generator in Figure 18. When the system is disconnected from Kendall and the infinite bus at 20 seconds, the electrical output power of the generator drops very slightly but this drop in generation is picked up by an increase in generation by the BESS. When the load increases by 10% at 40 seconds, the generator and BESS share this increase. The amount of the load increase that is shared by the BESS is affected by the setting of  $K_{pg}$ . In Figure 20 the BESS is generating about 30 kW (when the value of  $K_{pg}$  is 1) while in Figure B3 the BESS generates about 60 kW (when  $K_{pg}$  is 3). Also observable in Figure 19 is the decrease in rotor speed when there is an increase in the load the generator is serving. This decrease is not as great as when the generator picked up all of the load increase and the BESS was not in the system to share the load increase as was shown in Figure 17. Finally, the generator mechanical power is not shown here, but it matches the magnitude of the increase in generator electrical output.

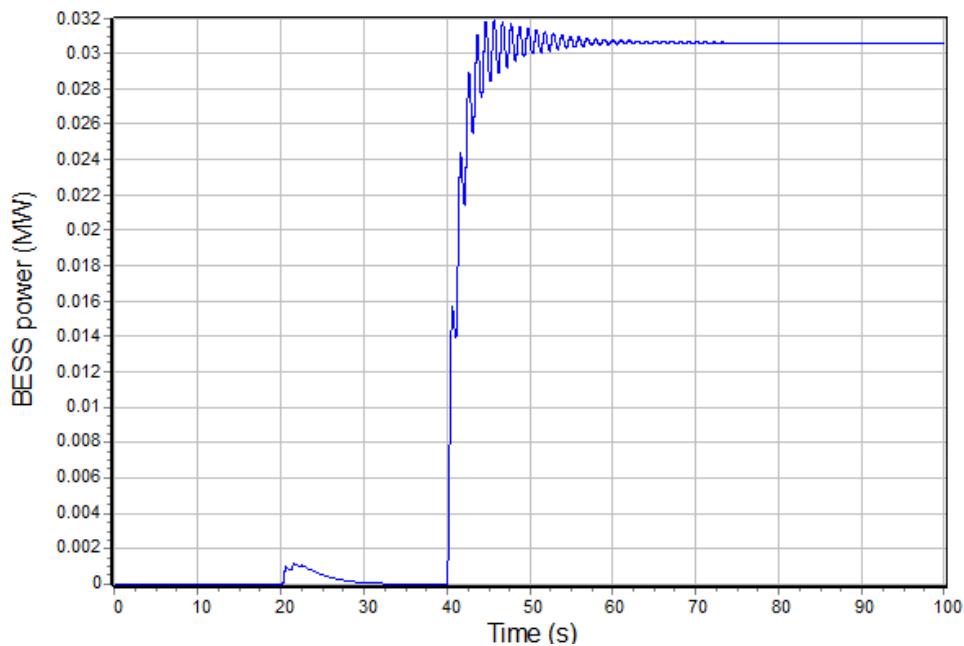

**Figure 20: BESS output with BESS  $K_{pg} = 1$**

### 4.3. Transient stability studies with BESS

With reasonable BESS parameter values chosen, the focus of the stability analyses shifted to making variations to the cases studied and observing the results. As previously described, there are several types of contingencies that can be analyzed. So far, the studies have included removing an element from the model (the line at Kendall connecting the microgrid to an infinite bus) and changing an element's associated values (increasing load in Glacier). Another major type of contingency is applying a fault. Given that the system being studied is already islanded, a fault is likely to cause more stability problems than could be sustained and so was not considered a relevant case to study. Instead, the additional cases that were studied were other variations of load increases and another setting for the internal voltage of the BESS. These were implemented with the same series of events described in section 4.1. The variations included a larger increase in load (with the same base load), smaller base load and a small load increase, and finally larger base load and a small load increase. Based on input from PSE, the internal voltage of the BESS was also changed in a simulation. The installed BESS has a voltage set-point that is greater than 100% of nominal in order to compensate for voltage drop of the transformers when supplying the islanded system. A summary of the simulations that were performed is shown in Figure 21.

#	Voltage setpoint (as compared to nominal)	Initial amount of load	Load increase	Figures
1	100%	1 MW	10%	18, 19, 20
2	100%	1 MW	25%	22, 23, 24, B4
3	103%	1 MW	25%	25
4	100%	0.5 MW	10%	26
5	100%	1.5 MW	10%	27

**Figure 21: Summary of microgrid transient stability simulations**

The first simulation that is considered is maintaining the same initial load, but having a greater load increase of 25% (simulation 2 described in Figure 21). Results for this are displayed in Figures 22 and 23. These figures show that with a 25% load increase, the system begins to have small oscillations that persist, rather than reaching a stable steady-state point. The BESS output power is included for reference in Appendix B, Figure B4. A greater load increase will result in a slightly greater decrease in rotor speed. This is valuable confirmation that care must be taken when considering how much load to add to a system at one time. In simulation 3, a similar effect occurs, but the spike in load bus voltage that occurs when the microgrid is isolated from the infinite bus is larger when the BESS' internal voltage is set greater than 100% of nominal. This large spike in bus voltage can be seen by comparing Figures 24 and 25 at 20 seconds, and could be a threat to system stability as well as the system's ability to stay within required voltage limits. Simulations 4 and 5 were performed to verify the system's performance with a smaller (0.5 MW) and larger (1.5 MW) initial value of load. Having less initial load results in less system stability while a larger initial load results in greater stability. These results are shown in Figures 26 and 27 where the rotor speed of the system with a base load of 0.5 MW has larger oscillations and takes longer to reach a stable point than a system with a base load of 1.5 MW. This result is to be expected and can be imagined visually by recalling the equal-area criteria, a simple way to visualize the effect of system changes on a single generator. This criteria graphs the generator power versus the rotor angle and is a way to analyze an imbalance in generator electrical and mechanical power that has been created by a large load increase or fault. The imbalance triggers a change in the rotor speed and rotor angle which can result in the system stabilizing at a new rotor angle where the generator

electrical and mechanical power are equal. Alternately, depending on factors that include the size of the initial system load or amount of load increase, the rotor angle can increase past a point where stability can be reached. Application of the equal-area criterion to systems with varied amount of pre-contingency load indicate that a return to a stable operating point is more difficult with a lower amount of pre-contingency load as was confirmed with this study [22].

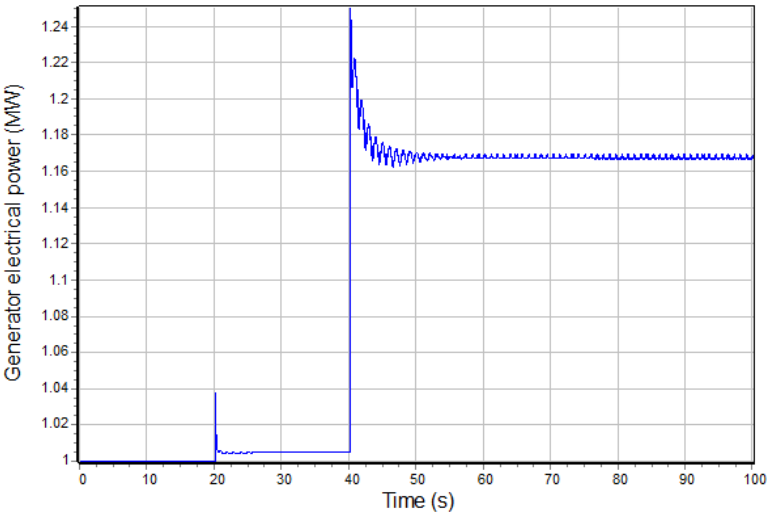

**Figure 22: Generator electrical power output, 25% load increase (simulation 2)**

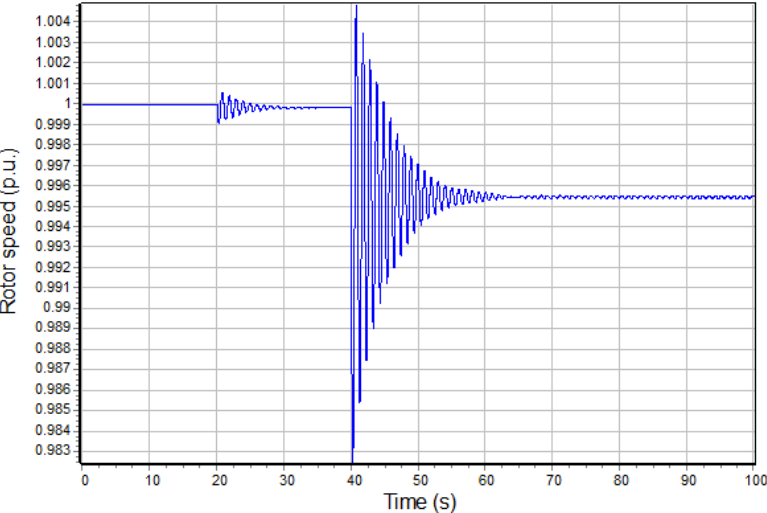

**Figure 23: Generator rotor speed, 25% load increase (simulation 2)**

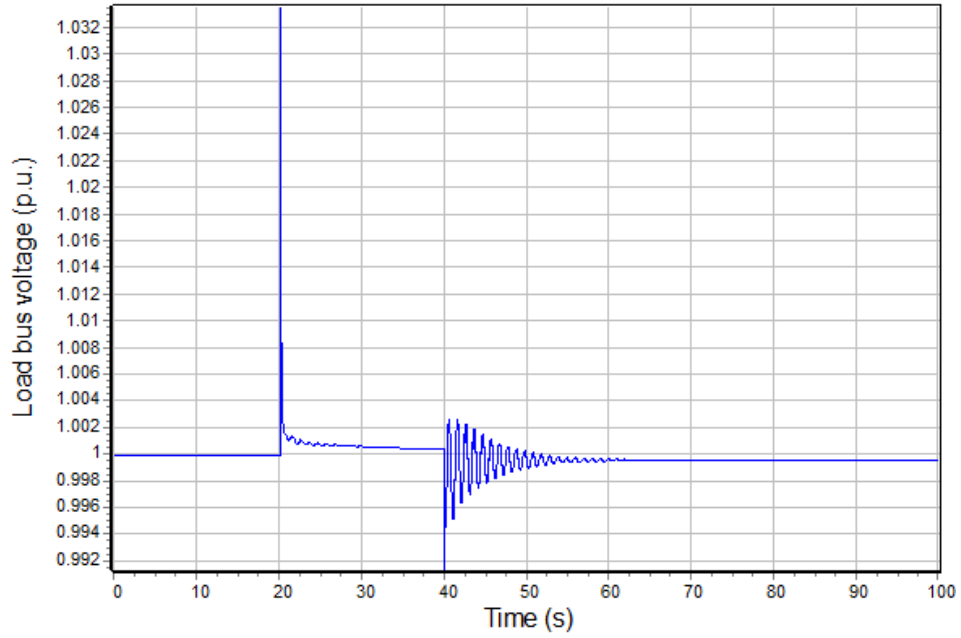

**Figure 24: Load bus voltage, BESS internal voltage is 1.0 p.u. (simulation 2)**

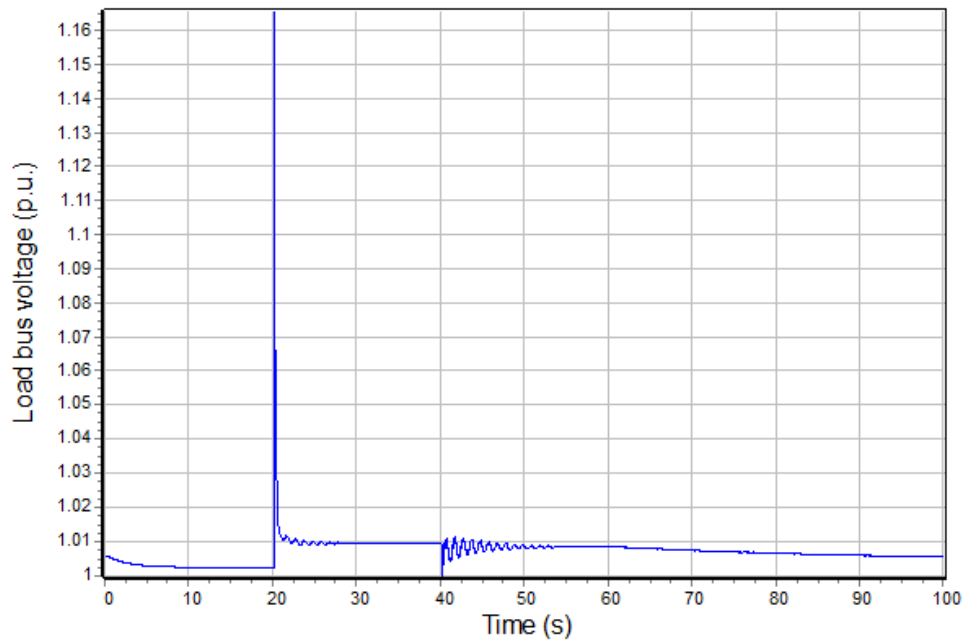

**Figure 25: Load bus voltage, BESS internal voltage > 1.0 p.u. (simulation 3)**

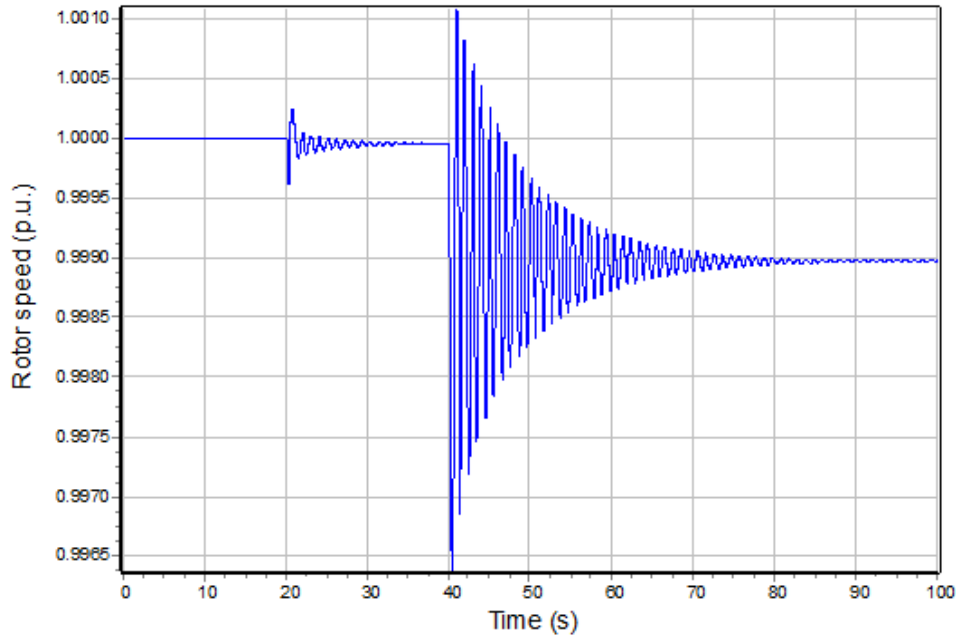

**Figure 26: Generator rotor speed, 0.5 MW base load (simulation 4)**

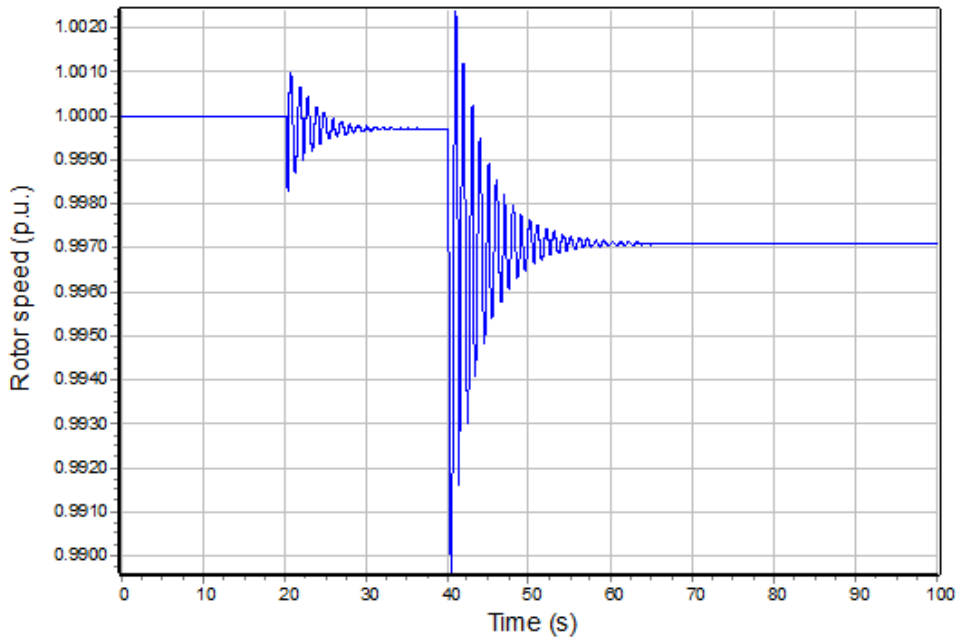

**Figure 27: Generator rotor speed, 1.5 MW base load (simulation 5)**

## 5. Conclusions and Future Work

### 5.1. Conclusions

This project developed a PowerWorld model for a microgrid incorporating small hydroelectric generation and a BESS. The transient stability of this microgrid was analyzed based on the system model, and use of the active power control capability within the BESS to provide frequency regulation was considered. The software used in the analysis allows for flexibility in terms of the type of models selected for each component of the system and also allows for a variety of types of transient contingencies to be analyzed. The particular site that was modeled and analyzed was a small microgrid being considered by Puget Sound Energy to improve reliability in a Washington mountain town. This proposed microgrid would utilize an existing small hydroelectric generation site and a new BESS. EPRI has developed generic dynamic models that can be used to model a variety of renewable resources, include BESS. The most important element of the BESS model for this project was a plant controller with active and reactive power control options that can provide frequency or voltage regulation to other devices.

The microgrid model parameters were selected with consideration of whether the simulation outputs were physically reasonable and consistent. In addition, the model performance was checked by plugging in results of a simulation of the generator's output into the first-order format of the swing equation. There were a few model parameters that were most important to tune in the governor and active power control loop of the plant controller in order to provide frequency regulation for the microgrid. In the governor these parameters were the gain and valve positioner time constant. In the BESS plant controller these key

parameters were the upside and downside droop and proportional and integral gain, with the gain being most critical to maintain stability.

A few key observations about operating a microgrid with a BESS and small hydroelectric generator were made, and these observations mostly pointed to areas of precaution for the implementation of a system like this. First, the amount of load that is added at one instant to a microgrid should be carefully determined. This was noted when considering a contingency with a large load increase as this system was less stable (by several measures) than the same system with a smaller load increase. Next, when determining how much load can be added to the microgrid, the amount of load that is already on the system should be taken into account. It was seen that a smaller initial or base load on the system leads to greater instability as the load level is increased when compared to a larger base load and the same load increase percentage. Finally, if the internal voltage of the BESS is larger than nominal caution must be taken to review the bus voltages within the system to ensure they stay within required limits.

Aside from these cautions, what was most notable about these simulations was that the BESS did provide frequency regulation for the small hydroelectric generator within the microgrid. For the case that was modeled in this paper, the model of some system elements did not replicate the existing system. Therefore quantitative results like how much load could be added before the system becomes unstable or how much the bus voltage would increase with a larger BESS internal voltage should not be considered definitive for that case. However, given that frequency regulation was possible in the model is encouraging and can provide motivation to further consider microgrids with BESS and small hydroelectric generation, while keeping the qualitative concerns described above in mind.

## 5.2. Future work

There are a few interesting areas for potential future work on modeling and analysis of microgrids that include small hydroelectric generation and BESS. First, if the modeled microgrid is to be implemented, it is beneficial to include dynamic model parameter selection based on manufacturer's data or onsite testing of the actual system. For the case reviewed in this paper, parameters for the governor and BESS were determined via estimation but more accurate parameters (from testing) would result in more accurate analysis results. Another potential area to study is control strategies other than the proportional control that was described and implemented. The BESS described in this paper was not modeled with the more common proportional-integral control, as it requires careful tuning. An additional area to model and analyze is the reactive power control loop that is available within the BESS REPC\_A block diagram to explore whether voltage regulation could be provided for a microgrid containing small hydroelectric generation. Finally, the model of the load and distribution in a microgrid could be further developed. For example, it can be modeled with a dynamic model or as a combination of constant power, current, and impedance. In the case study in this paper the load was modeled as constant power. The distribution lines and transformers are also not included in the system modeled, and their inclusion would provide additional value. This more detailed modeling can be beneficial for microgrid systems that typically have low inertia and therefore difficulty remaining stable. Note that PowerWorld does not presently allow for modeling the unbalanced three-phase systems that are typical of distribution networks, so another software program would be required.

## References

- [1] A. A. Akhil. "DOE/EPRI 2013 electricity storage handbook in collaboration with NRECA," Sandia Lab., Albuquerque, NM, Rep. SAND2013-5131, July 2013.
- [2] N. Demerice. (2015, Oct). *Clean energy fund update*. [Online]. Available: <http://www.commerce.wa.gov/Documents/Clean-Energy-Fund-Update.pdf>
- [3] B. Sweet, "California's first-in-nation energy storage mandate," *IEEE Spectr.*, Oct. 2013. [Online]. Available: <http://spectrum.ieee.org/energywise/energy/renewables/californias-firstinnation-energy-storage-mandate>
- [4] C. Helston. (2012, May). *Run of River*. [Online]. Available: <http://www.energybc.ca/profiles/runofriver.html>
- [5] *Micro-hydro power*. [Online]. Available: <http://practicalaction.org/micro-hydro-power-3>
- [6] *Small Hydropower*. [Online]. Available: <http://www.snopud.com/PowerSupply/hydro/lihydro.ashx?p=1517>
- [7] *About Microgrids*. [Online]. Available: <https://building-microgrid.lbl.gov/about-microgrids-0>
- [8] *Microgrids*. [Online]. Available: <http://w3.usa.siemens.com/smartgrid/us/en/microgrid/pages/microgrids.aspx>
- [9] *Hurricane Sandy*. [Online]. Available: [https://en.wikipedia.org/wiki/Hurricane\\_Sandy#cite\\_note-SandyTCR-1](https://en.wikipedia.org/wiki/Hurricane_Sandy#cite_note-SandyTCR-1)
- [10] J. Bonazzo. (2015, July 16). *New York State Invests in Microgrids Through NY Prize Competition*. [Online]. Available: <http://observer.com/2015/07/new-york-state-invests-in-microgrids-through-ny-prize-competition/>
- [11] Jan Machowski, Janusz Bialek, and James Bumby, *Power System Dynamics*, 2<sup>nd</sup> ed. West Sussex, UK: Wiley, 2008.
- [12] N. Jayawarna et al., "Stability of a Microgrid", *The 3<sup>rd</sup> IET International Conference on Machines and Drives*, Dublin, Ireland, 2006, pp. 316-320.
- [13] S. X. C. Quintero et al. "Feasibility of intentional Islanding operation with small hydropower plants," in *Transmission and Distribution: Latin America Conference and Exposition*, Montevideo, Uruguay, 2012, pp. 1-6.

- [14] R. Kamel, A. Chaouachi, and K. Nagasaka, "Detailed analysis of micro-grid stability during islanding mode under different load conditions", *Engineering*, vol. 3, no. 5, pp. 508-516, May 2011.
- [15] "Glacier Planned Islanding & Microgrid Feasibility Assessment", Puget Sound Energy, Unpublished.
- [16] J. Roach. (2015, Apr. 29). *Will Huge Batteries Save Us From Blackouts?* [Online]. Available: <http://news.nationalgeographic.com/energy/2015/04/150429-batteries-grid-energy-storage/>.
- [17] (2015, Jan. 12). *Glacier Battery Storage Project*. [Online]. Available: <http://www.commerce.wa.gov/Documents/PSE-Glacier-Overview-CEF-Outreach-020915.pdf>
- [18] *Nooksack Falls Hydroelectric Power Plant*. [Online]. Available: [http://en.wikipedia.org/wiki/Nooksack\\_Falls\\_Hydroelectric\\_Power\\_Plant](http://en.wikipedia.org/wiki/Nooksack_Falls_Hydroelectric_Power_Plant).
- [19] E. Ewry, private communication, January 2015.
- [20] *PowerWorld Simulator 18 Block Diagrams*. [Online]. Available: <http://www.powerworld.com/files/Block-Diagrams-18.pdf>.
- [21] J. Heil, private communication, May 2015.
- [22] Prabha Kundur, *Power System Stability and Control*, New York, NY: McGraw-Hill, Inc., 1994.
- [23] J. Hines, private communication, May 2014.
- [24] *IEEE Recommended Practice for Excitation System Models for Power System Stability Studies*, IEEE Standard 421.5, 1992.
- [25] A. Aquino, private communication, June 2015.
- [26] P. Pourbeik. "Model user guide for generic renewable energy system models," EPRI, Rep. 3002006525. June 2015.
- [27] P. Pourbeik. "Specification of the second generation wind turbine generators," EPRI, Jan. 2014.
- [28] P. Pourbeik. "Simple model specification for battery energy storage system", EPRI, Jan. 2015.
- [29] *PID for Dummies*. [Online]. Available: [http://www.csimn.com/CSI\\_pages/PIDforDummies.html](http://www.csimn.com/CSI_pages/PIDforDummies.html).

# Appendix A

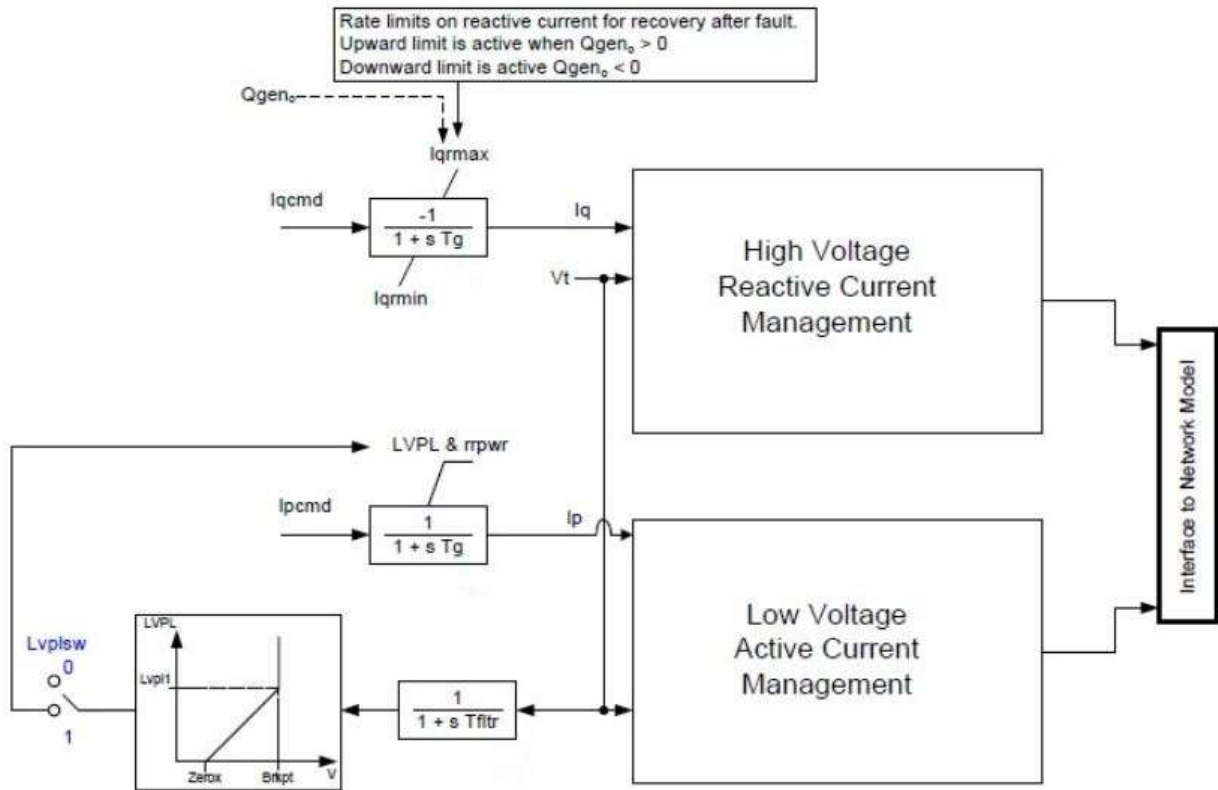

Figure A1: REGC\_A block diagram [20]

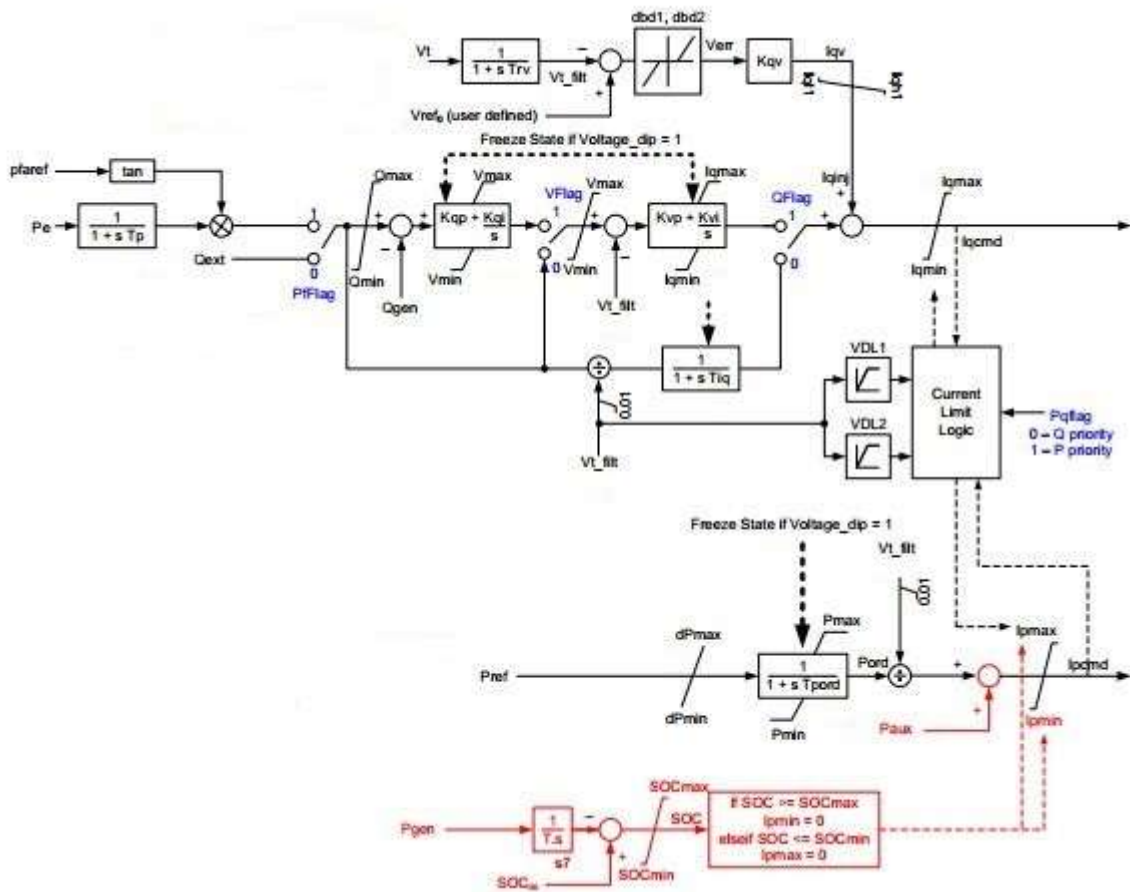

Figure A2: REEC\_C block diagram [28]

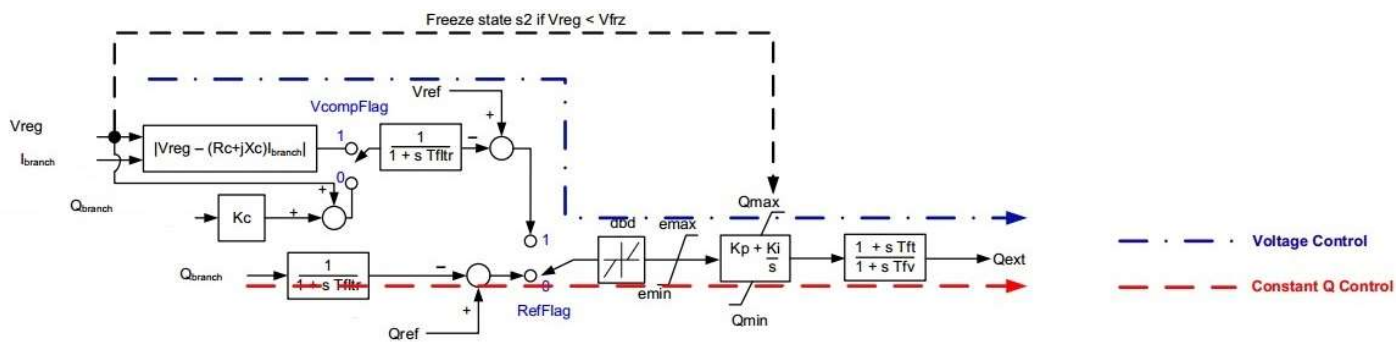

Figure A3: REPC\_A reactive power control block diagram [28]

# Appendix B

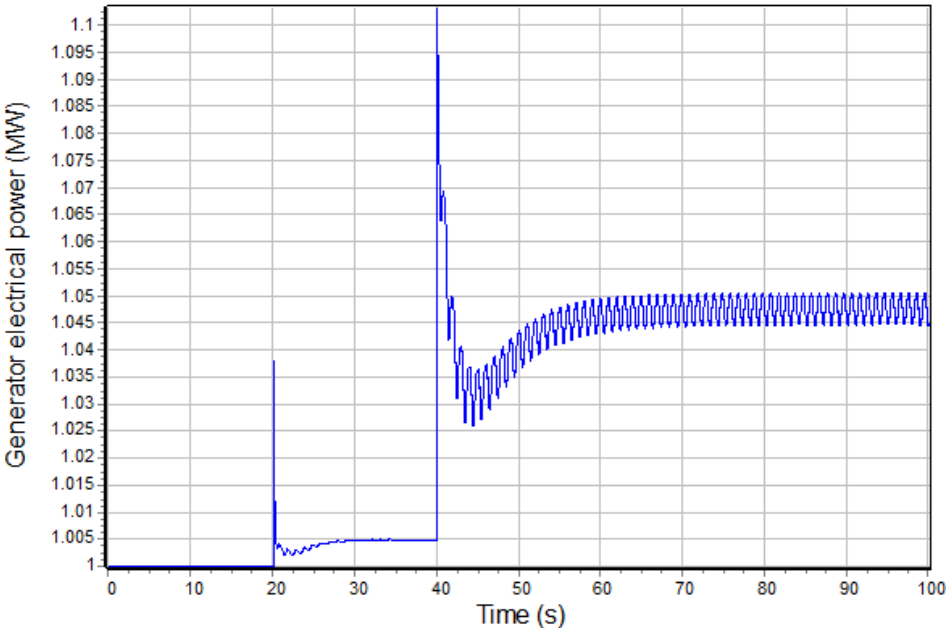

Figure B1: Generator electrical power output with BESS  $K_{pg} = 3$

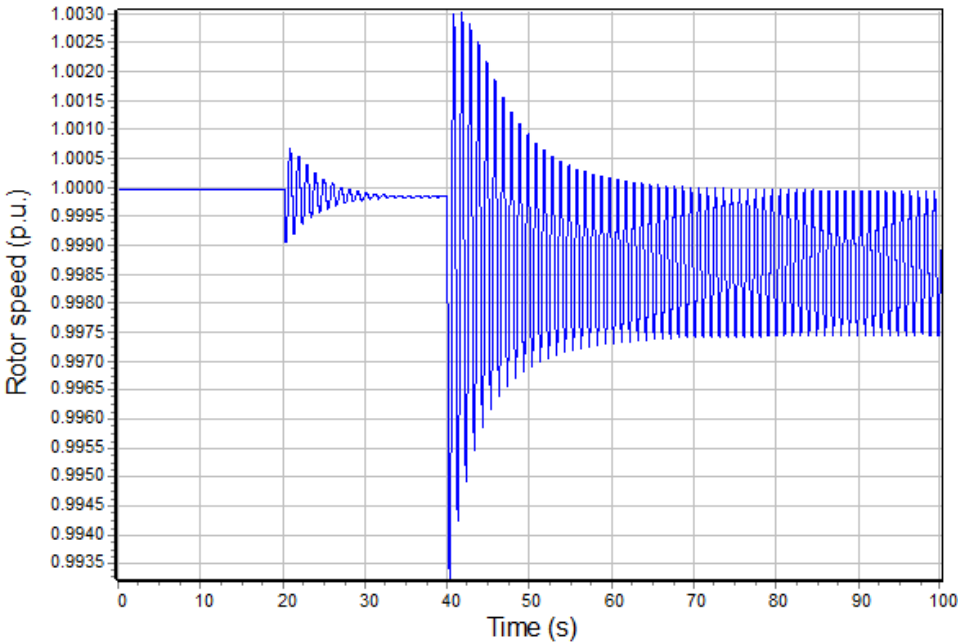
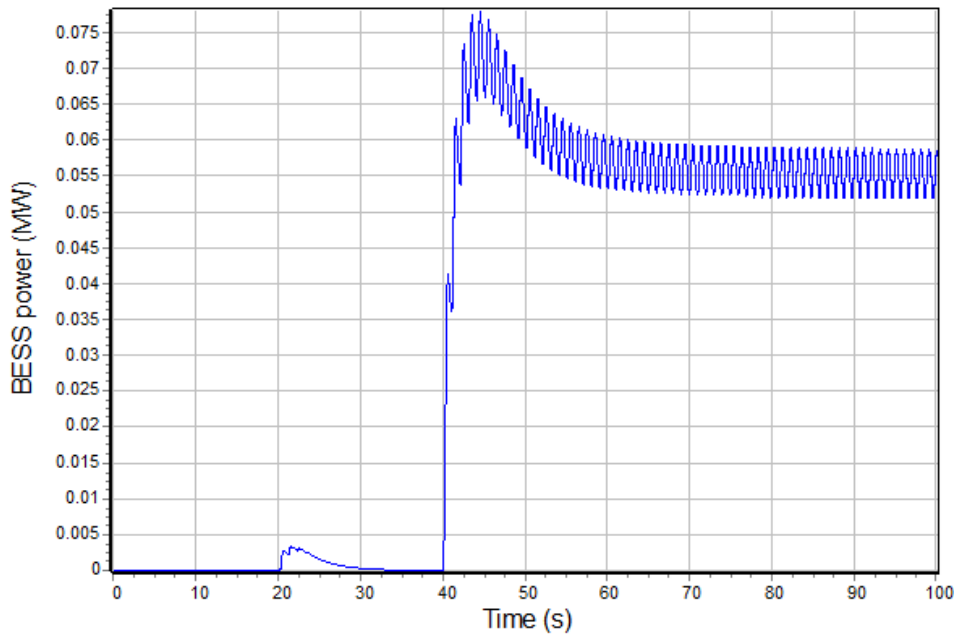
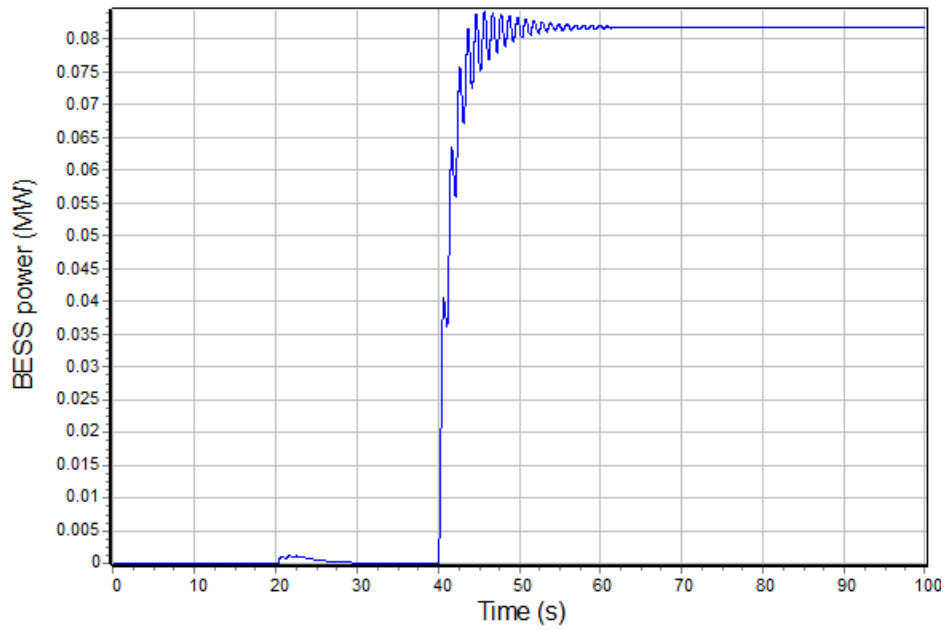

Figure B2: Generator rotor speed with BESS  $K_{pg} = 3$



**Figure B3: BESS output power with BESS  $K_{pg} = 3$**



**Figure B4: BESS power, 25% load increase (simulation 2)**