

little House on the Alley
Seeking an Ethic of Development for DADUs in Seattle

Ryan Nels Jorgensen

A thesis

submitted in partial fulfillment of the
requirements for the degree of

Master of Architecture

University of Washington

2013

Committee:

Elizabeth Golden [Chair]

Rob Corser [Co-chair]

Gundula Proksch

Rick Mohler

Program Authorized to Offer Degree:

Architecture

© Copyright 2013
Ryan Nels Jorgensen

All images and graphics were produced by
the author unless otherwise noted.

ACKNOWLEDGEMENTS

I would like to thank my all of my professors for their continual support and inspiration.



Ballard alleyway



Ballard alleyway

TABLE OF CONTENTS

I.	INTRODUCTION	3
II.	SMART GROWTH	5
III.	SEATTLE	6
IV.	DADUs	13
	Benefits	15
	Drawbacks	18
V.	RESIDENTIAL ALLEYWAYS	23
VI.	CASE STUDY SITE: BALLARD	35
VII.	AN ETHIC OF DEVELOPMENT	39
	Code	41
	Site Relationship	43
	Orientation	47
	Climate	49
VIII.	DESIGN	51
	Construction	65
	Materiality	67
IX.	CONCLUSION	79
X.	BIBLIOGRAPHY	80

“The essence of settlement consists in gathering, and gathering means that different meanings are brought together.”

Christian Norberg-Schulz,
Genius Loci



80% in Urban Areas

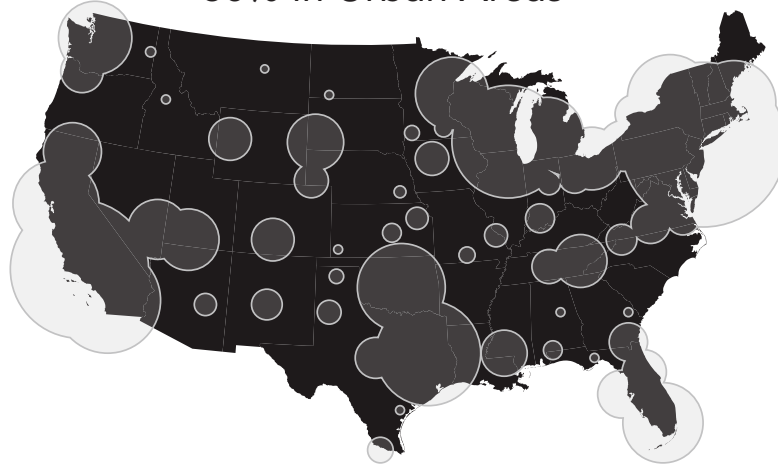

I. INTRODUCTION

In the United States 80% of the population lives in urban areas. The manifestation of allowing urban areas to accept greater density often results in a pattern of disruption, displacement, and destruction. For this thesis an alternative form of densification is explored that focuses on integration, infill, and maintaining the integrity of existing built fabric. To achieve this development is looked at on a macro and micro level and code was approached with a humane sensitivity in order to explore ways in which we can better grow as a city, a culture, and a community.

In 160 years Seattle has grown from a territorial settlement of a few hundred into a major international center of culture and commerce over half a million strong and growing. In order to achieve smart growth and development available land and infrastructure needs to be used in more effective ways while remaining conscious not to sacrifice the very essence that makes Seattle the unique place it is. We have a responsibility to those who came before us and to those who will come after us to be stewards of our culture, our built environment, and our natural environment alike.

This thesis explores ways in which Detached Accessory Dwelling Units (DADUs) can help transform residential alleyways into vibrant sub-places by following an ethic of development that promotes socially engaging, economically viable, and environmentally responsible design. This will be done by exploring construction and detailing potential of off the shelf materials, revitalizing public right-of-ways as social spaces, and through careful analysis of climate and context. The design project is a conceptual case study and argument for the creation of codes, guidelines, and incentives to include residential alleyways in the greater conversation of development and density in Seattle.

"Only when understanding our place, we may be able to participate creatively and contribute to its history."

Christian Norberg-Schulz,
Genius Loci

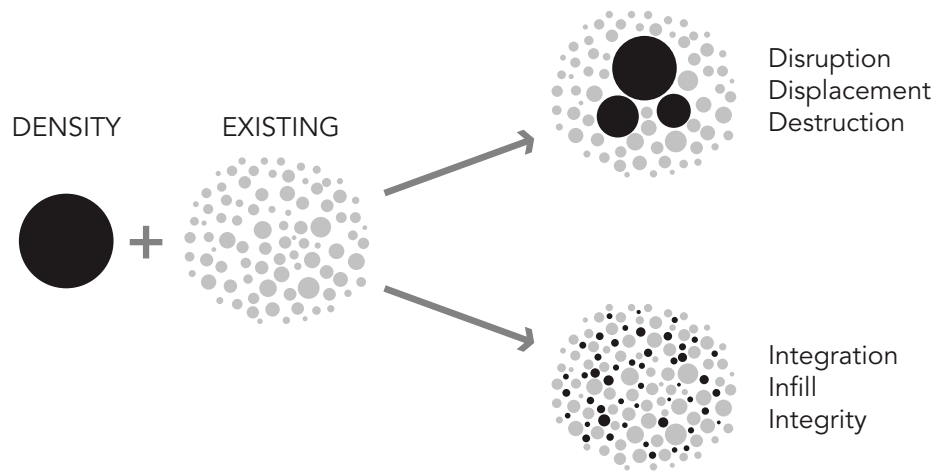

II. SMART GROWTH

When approaching the topic of density three issues must be acknowledged: Seattle is growing—in order to achieve smart growth and development we must live smaller, denser, and closer. Resources are limited—to better manage what is available we must reduce, reuse, and recycle. The success is measured by the triple bottom line—it must be economically viable, socially engaging, and environmentally responsive. How can architecture be used to address these issues in a positive way?

Before the term ‘sustainability’ was coined (and subsequently used to a point of meaninglessness) the motto of green living was: Reduce, Reuse, and Recycle. For many recycling is their only conscious attempt at green practices and an easy alternative to a garbage can. Recycling is an energy intensive and resource demanding process that can be minimized by simply reducing what we consume and reusing what we already have. If the true goal of sustainability is to achieve an existence in balance with our environment then Reduction and Reuse must be brought back to their respective places in the hierarchy of green fundamentals. If the built environment is to help us achieve this goal then we must reduce architecture to simple, effective, and efficient building(s) and reuse existing land and infrastructure.

To reduce architecture is to eliminate superfluous elements which results in a simplification of building(s). This simplicity is not stylistic minimalism but rather a practice of restraint where strategic architectural maneuvers yield the greatest functional results. Though the resulting architecture may appear outwardly basic a deeper inspection reveals a complex network of integrated systems and relationships. Reduction and simplification does not lead to aesthetic banality but instead creates a more efficient, effective, and pure architecture where beauty is expressed in an honest fulfillment of purpose by each essential part.

The most environmentally friendly structure is the one that is already built. Embodied energy of existing infrastructure, materials, and systems are resources in and of themselves. Spaces that are underutilized, abandoned, or neglected great potential to become catalysts for social engagement and interaction. Derelict areas can be transformed, if only temporarily, to create vibrant and much loved places within communities using stock that is already an established part of the built fabric.

“By the reduction of needs and consumption, the disruption potential of buildings with regard to equilibrium in the environment can be reduced. The law of economy should lead to a specific (passive) architecture that uses resources sparingly.”

Christian Schittich,
In Detail Building Simply

“We cannot build our way to sustainability; we must conserve our way to it.”

Carl Elefante

III. SEATTLE: City of Neighborhoods

“Because of a particular combination of favorable conditions, Seattle is more than just a city; it is a very special, unique place. These favorable characteristics are its unsurpassed natural setting, combining greenery, hills, and water, and its proximity to the country and natural waterways; the pleasant changing, temperate climate; and the adventurous, freedom-loving, friendly people who live here. The people have made and are making the city, and it in turn exercises its influences upon their destinies.”

Victor Steinbrueck,
Seattle Cityscape

Seattle is a boom-and-bust city that has grown from timber to technology and from gold rush to grunge. Its location at the farthest reaches of the lower 48 and its abundance of natural resources and beauty has drawn adventurers, entrepreneurs, and investors alike. Seattle is young, progressive, liberal, and environmentally conscious; particularly when compared with other American cities of similar size. It is a city where nature abounds: 14% of the city is preserved for open and green space. Parks, tree lined streets, clean water and air are the norm, and access to the solace of a forest, a river, or a mountain is never more than an hour away. Seattle is at the forefront of green development with politicians, planners, and citizens who are dedicated to helping our natural and built environments thrive. The influence of the city’s surrounding natural wonders and the pioneer spirit can still be felt in the streets, arts, industries and politics of this region. All of these things draw people to Seattle and will continue to do so long into the future.

Seattle had its start along the shores of Elliott Bay near what today is Pioneer Square. During the time of its growth and expansion other cities were also established on the stretch of land between the Puget Sound and Lake Washington. Because of its deep sea port and railroad access Seattle saw great economic growth and therefore needed to expand in order to accommodate its increasing population. By the turn of the century the city had grown to encompass all available lands from the shores of Lake Washington in the east, Beacon Hill in the south, and had fully encompassed Lake Union and Green Lake to the north.

The economic boom brought about by industry and export meant the city of Seattle needed more land to house an ever growing population. Between 1905 and 1910 Seattle annexed eight surrounding cities, effectively doubling its size and establishing many of the neighborhood centers that we know today. The independent cities of Ballard, Columbia City, Georgetown, Ravenna, South Seattle, South Park, Southeast Seattle, and West Seattle, complete with their own town cores, main streets, and characteristics, had all become part of the city of Seattle.

The city’s rapid growth was paralleled by a dramatic residential development. The early years of expansion helped shape the character and fabric of the city: neighborhood cores surrounded by vast plats of single-family homes. One of the unique characteristics that makes Seattle so livable and attractive is that one can attain the dreams of suburbia in the bustle city. Here it is possible to live in a house with a yard on a tree lined street and still have access, by foot, bike, or bus, to cultural and civic amenities all within one’s own neighborhood.

Former mayor Greg Nickels called Seattle as a ‘City of Neighborhoods’ and although no official neighborhood boundaries have existed in Seattle since 1910 these original city cores and subsequent cores that have grown between them help define the unique districts and



neighborhoods that give the city this distinction. It is not only the number of neighborhood cores that define the city but the prevalence of detached homes that surround them. Most of these residential neighborhoods were established during the early boom years to house the influx of workers moving to Seattle and are emblematic of life in the city today.

In Seattle 49% of the land is zoned for single-family use, 46% of all housing units are detached single-family homes, and because single-family homes have higher average household size just over half of the population lives in a single-family detached home. The bulk of these homes were built during times when resources were cheap, families were larger, and mentalities and lifestyles were different. In Seattle the median value for a single-family home is \$453,000 and with a median household income of \$62,000 this prices most residents out of purchasing a detached single-family home in the city.

Even with the boom and bust cycles that Seattle has experienced in the past it continues to grow and thanks to its strong economy, industries, favorable environment, and progressive culture it is poised to continue this trend long into the future. The population of Seattle is projected to grow from its current 630,000 inhabitants to a city of 800,000 in the next 25 years. Where, how, and in what capacity this populace will be housed is a question that has been and continues to be debated amongst politicians, planners, investors, developers, and citizens. In Seattle 80% of land is zoned for single-family, industrial, open space, or major institution leaving the remaining 20% to accept the majority of this growth.

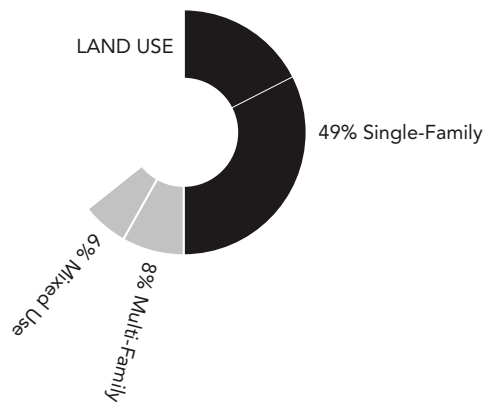

Around the turn of the millennium serious debate began on how Seattle and the greater King County region should grow and densify. In 1990 the State Growth Management Act created boundaries for urban growth within the county. In the mid-2000s overlay zoning was created to establish Urban Centers and Urban Villages within the city of Seattle. These newly zoned urban cores were aimed at allowing neighborhoods to accept greater density, infill, and new commerce in and around their established or potential centers. All together five Urban Centers and twenty five Urban Villages were created across the city; seven of which were the original cities annexed by Seattle one hundred years earlier.

The Urban Village overlays allow for greater density, increased building height, and mixed use of residential and commercial. These new zoning regulations brought much needed housing and commercial opportunities to many areas of Seattle and allowed for the revitalization and creation of many neighborhood cores. These redevelopments also led way for the improvements of civic and cultural amenities and an increase in the demand for and use of public transportation. In many ways the creation of Urban Villages has been a successful example of smart growth and has brought much needed housing, commerce, transportation, and amenities to many Seattle neighborhoods.

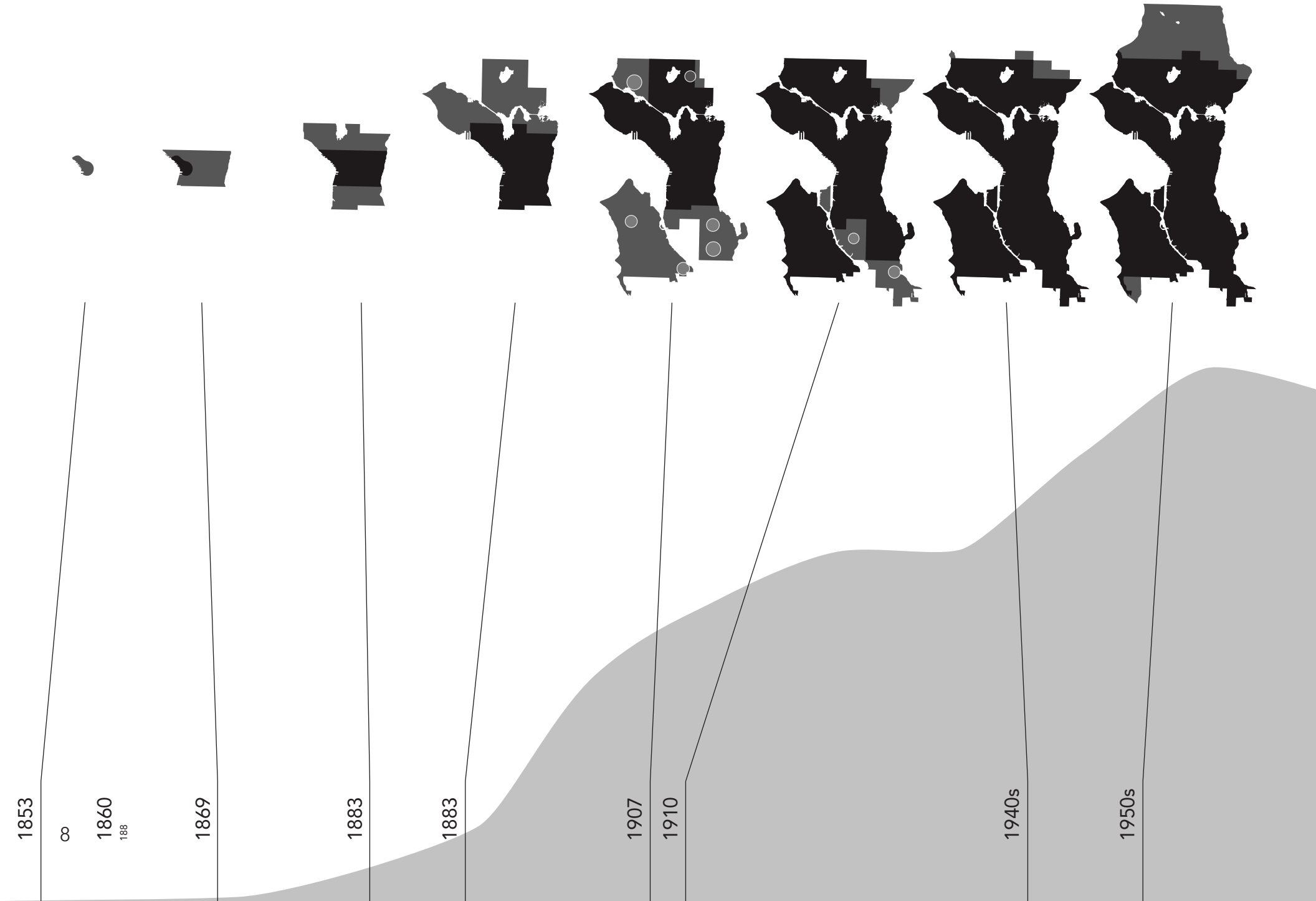

Growth in Seattle

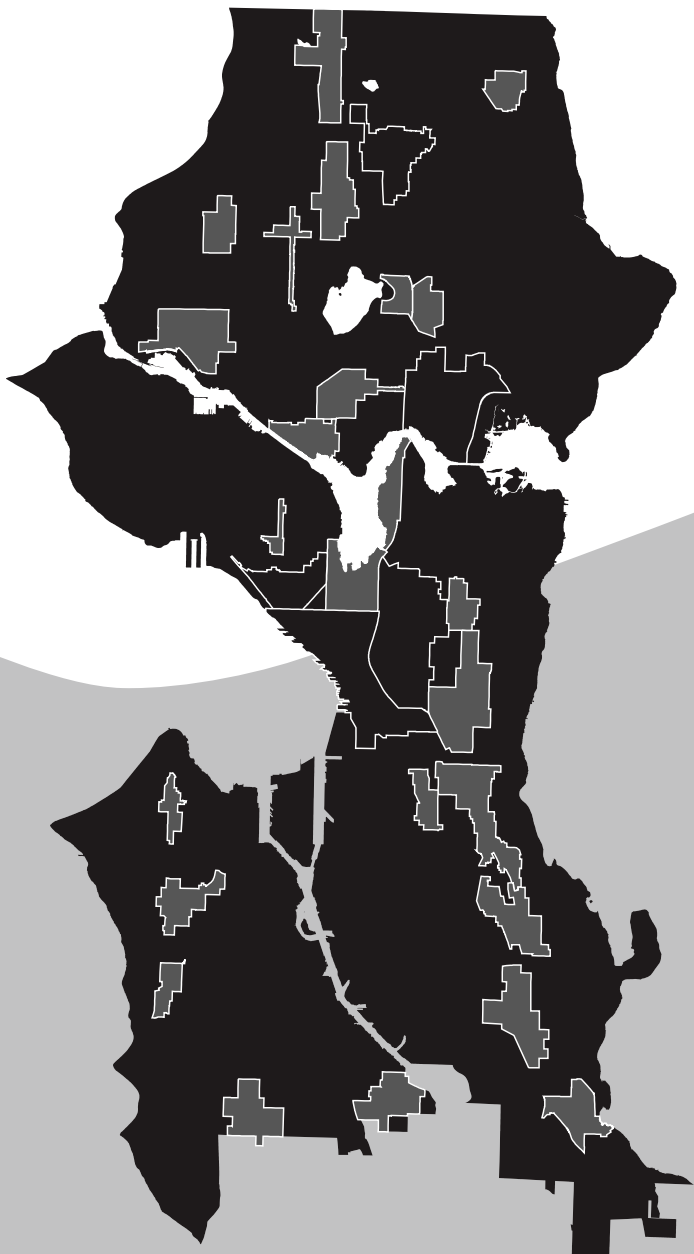

2000s

2012

634,535

2040

800,000

2???

1,000,000+

Edith and Goliath

Impetus and
Inspiration



As much good as the creation of such zoning overlays and developments has given to the neighborhoods of Seattle it has not come without its fair share of critics, pushback, and backlash. The citywide implementation of such a dramatic rezoning has largely been left in the hands of private developers. Unfortunately this has led to uncontrolled developer driven projects which often replace entire blocks of multi-aged, multi-function, fine grain infrastructure with monolithic structures that are at odds with the scale, texture, pace, and character of the place in which they are built. The construction of multi-unit buildings with 50 or more units has seen the greatest rate of increase, particularly within the past five years. These massive monoculture developments have also resulted in the loss of much of the affordable rental spaces thus displacing small local businesses and lower income residents.

Urban Village zoning overlays are not strictly limited to the main commercial corridors but also spill over into surrounding areas traditionally zoned for single-family residences. These boundaries have been drawn in order to create a mid-rise buffer between denser high-rise commercial and multi-use neighborhood cores and the surrounding low-rise single-family neighborhoods. In these residential overlay zones multi-story multi-unit buildings such as townhomes, duplexes, apartments, condos, and aPodments can be built on single or multiple single-family lots.

Because of the zoning overlay and their multi-unit classification these newer denser buildings can be built with a different set of regulations than their single-family neighbors. Rules regarding setbacks, height, size, and parking have caused backlash and complaints of increased traffic and noise, overcrowding of street parking, and blocked views and daylight. Urban Village zoning overlays do create opportunities for residential areas to accept infill however; the manner in which this infill is implemented destroys the inherent character of these traditionally single-family neighborhoods. New high-density structures fail to fit in with the scale, materiality, and rhythm of the single-family neighborhoods in which they are built.



IV. DADUs

There is no doubt that Seattle needs to accommodate for greater density in urban cores but how can surrounding single-family neighborhoods accept infill without destroying their fine grain residential character? The most viable solution to achieve this is by allowing homeowners to build accessory dwelling units or ADUs on single-family lots. The City of Seattle Department of Planning & Development defines an ADU as: A room or set of rooms located in a home (or in a separate structure that shares a lot with a single-family home in a single-family zone or a rowhouse or townhouse in a low-rise zone in the case of detached accessory dwelling units or Backyard Cottages) which has been designed or configured to be used as a separate dwelling unit. It generally includes living, sleeping, kitchen, and bathroom facilities and has a lockable entrance door. ADUs are colloquially known by many names: granny flat, in-law suite, back yard cottage, laneway house, sidekick, and carriage house depending on layout, location, and region. For the purpose of simplification all detached accessory dwelling units shall be referred to henceforth as DADUs.

Since 1994, the City of Seattle has allowed accessory dwelling units that are inside, or attached to the main house. In September of 2006, the City adopted legislation for a pilot program that allowed for the creation of new or conversion of existing structures to be used as detached accessory dwelling units (DADUs), also known as Backyard Cottages (BYCs), for homeowners living in Southeast Seattle (south of I-90 and east of I-5). After examining the cottages that were built in Southeast Seattle, the City allowed Backyard Cottages citywide in December of 2009. [City of Seattle DPD]

Codes relating to the construction of DADUs are fairly straight forward but do have allowances and exceptions with regards to specific conditions. Generally DADUs must be a freestanding structure that shares a lot with a single-family house on a lot that is at least 4,000sf in size. Either the main house or DADU must be owner-occupied for six months of the calendar year. The DADU must not exceed a gross floor area of 800sf including parking and storage and must be located in the rear, or sometimes side, yard. Regulations regarding height, setbacks, and orientation are based on specific lot conditions such as size, width, and accessibility to public right-of-ways such as alleyways and side streets. In Seattle, 35% of single-family lots have alley access. In these cases DADUs can be built directly on the alley fronting lot line.

With the original pilot program the City of Seattle created a set of guidelines regulating the implementation and construction of DADUs. Since the program began annual reports have been published which survey the construction, design, and impacts of DADUs. Over the years using reports and observations these guidelines have been refined to include comprehensive information about site planning, architectural design, materials, green design, universal accessibility, privacy, prefabrication, permitting, and construction. These annual reports and guidelines also highlight the social, economic, and environmental benefits of DADUs further making the case for their construction in the city.

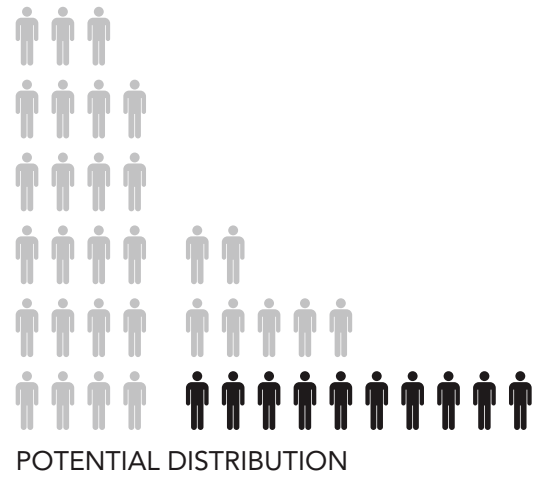
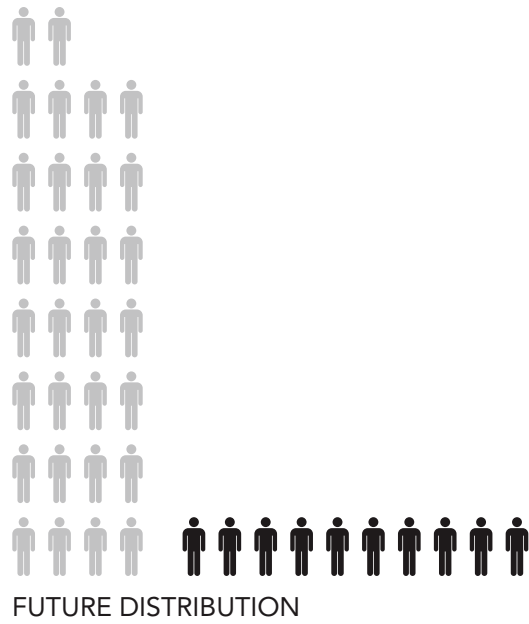
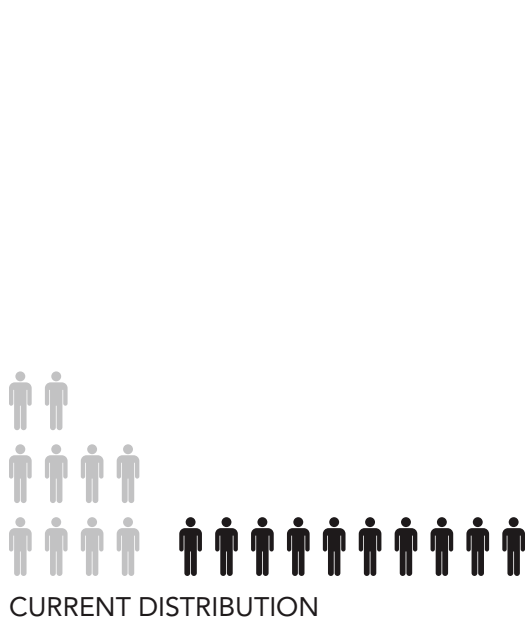
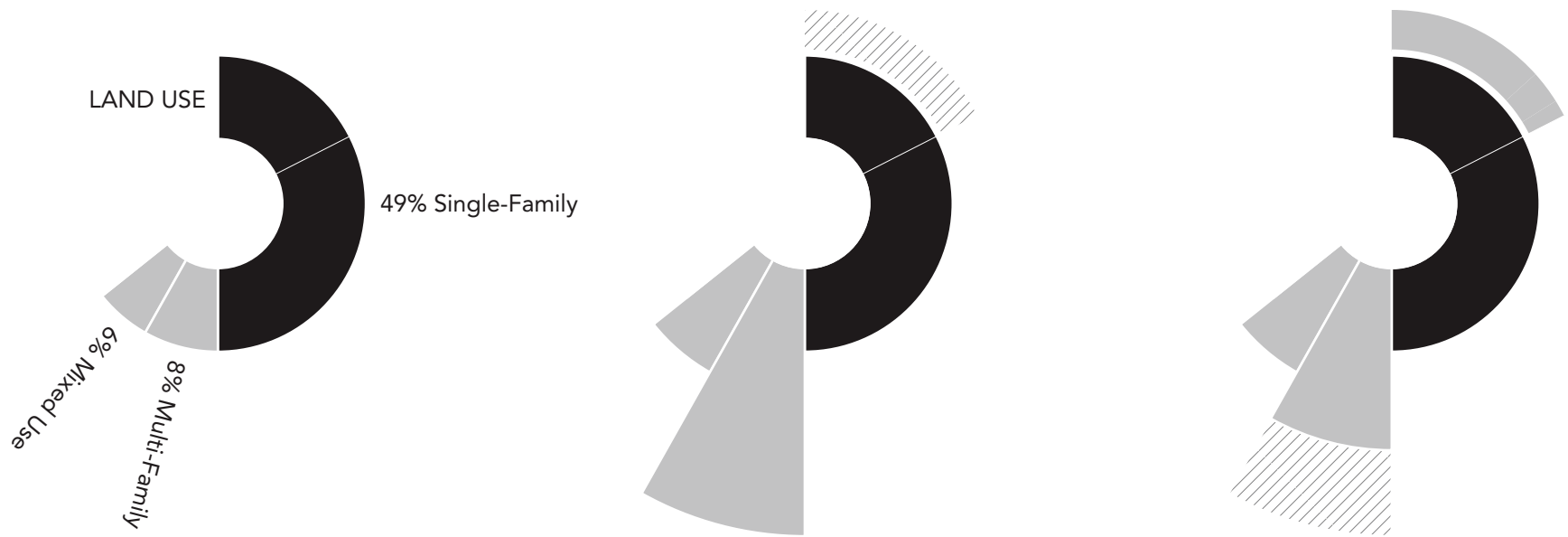

Benefits

Small dwellings such as DADUs make economic sense in terms of construction, maintenance, operation, and investment. Smaller size reduces material needed for construction and overall site preparation. This coupled with light construction methods and/or prefabrication further brings down material costs and speeds up construction time. Maintenance such as repainting, general repairs, and reroofing is quicker and less labor intensive than on larger standard homes. Operational costs too are reduced. Less space means less volume to heat, cool, and ventilate. This means that loads on mechanical systems are greatly reduced if not eliminated altogether. With the small load demand highly efficient mechanical systems can be used to further reduce operational costs. Additionally systems such as photovoltaics can be used to generate energy for the DADU and/or the main house.

There are many ways to build a DADU in an affordable manner but the investment potential far outweighs the cost of construction, maintenance, and operation. Depending on total cost of construction and desirability of location investment can be recouped through rent in as little as five years. After this additional income can be used to pay off a mortgage, go towards retirement or a college fund, pay for upkeep or improvements to the main house, or simply to have peace of mind in a reliable stream of revenue. Add to this the improvement of the property itself and DADUs just make sense. This is not only a benefit to homeowners but also to the community at large. DADUs supply renters with alternative forms of housing at competitive rates to high-rise unit.

DADUs provide the opportunity for members of a community and residents of a neighborhood to remain in their surroundings throughout the changing stages and needs of life. They provide a place where children can foster a sense of independence, where young families can get a first start, where guests can be comfortably accommodated, where an aging parent can be cared for, and where a homeowner can one day retire to. The flexibility of housing options that DADUs provide effectively allows people to age in place, either in their same neighborhood or on their same property.

DADUs not only provide elastic options to homeowners themselves but also provide much needed housing alternatives for renters. Young families who cannot yet afford their own home, single professionals looking for an alternative to high-rise urban core life, individuals or families who prefer to live close to their jobs and or schools, independent elderly who wish to forgo the maintenance and size of a typical single-family home, or those who are just looking to downsize but still live in a residential neighborhood. Renters who later wish to own a home have the ability to remain in the same neighborhood and community that they have invested in.



Creating a greater diversity of housing options within a neighborhood also diversifies the demographic of that neighborhood. Living in greater proximity to a diverse community creates opportunities for interaction and fostering an understanding of one's neighbor, whatever walk of life they may come from. Knowing the members of one's community creates a safer and more social environment for everyone involved. Additional population within a neighborhood increases use of and demand for civic amenities such as public transportation and libraries. Unlike other types of rental units homeowners keep a vigilant eye to protect their investments. Maintenance of this personal property ensures that DADUs do not become dilapidated eyesore within the community.

The environmental benefits of DADUs are inherent to their size. A smaller dwelling uses fewer raw materials to build, has a smaller footprint which reduces site disturbance, and has a lower operational energy demand. The reduction in envelope size creates a tighter tolerance for its performance, allowing the dwelling to function more efficiently. On a macro scale DADUs allow existing neighborhoods to accept infill without destroying their character or loss of existing building stock. Their small size allows them to be built in areas otherwise unsuited for high density structures. They tap into and use existing infrastructure and services with little additional impact or disruption.

There is a fundamental quality to small dwellings and the edited lifestyle they encourage. Having an intimate relationship with one's shelter, using only as much space as needed, and occupying that space with only the most essential possessions gives one a sense of satisfaction and liberation from material goods. When dwelling space is limited, such as in DADUs, one is compelled to focus on quality rather than quantity thus putting priority of usefulness over desire. Many who choose to downsize feel a sense of pride in their curb of consumption and reduction of footprint.





DADUs have what most small scale dense dwellings do not: exterior spaces. These are important areas that can be customized to outwardly express individuality and create a sense of identity within the greater community. It is also in these exterior spaces where chance interactions that establish social bonds occur. The importance of semi-private and semi-public spaces such as yards, gardens, stoops, porches, and sidewalks cannot be stressed enough for these are the historic places of gathering and exchange within residential communities and the places that foster a sense of belonging to a neighborhood.

By scaling down the size of a detached dwelling the line between inside and out is broken down and nature is brought closer to the inhabitant. Small dwellings, close to the ground, and with views of the outdoors provide a constant reminder of the natural setting and environment of which we are a part. By breaking down the barriers that large scale creates we become more in tune with natural cycles and rhythms and obtain a greater understanding of how our existence is impacted and, more importantly, impacts the world around us.

A disconnect from nature has been attributed to an increasing number of physical and psychological health issues such as obesity, stress, memory loss, and attention deficit hyper activity disorder. A key element of healthy architecture is the integration of nature and natural systems. In a region so defined by its nature this connection takes on an additional significance. For millennia humans have lived in synch with nature and its cycles; the seasons, weather, the rising and setting of the sun, migration, harvest, et cetera. The psychological and physiological benefits of this connection are difficult to quantify but are no less important to our health and happiness. How can one calculate the importance of the smell of rain or the aural benefits of songbirds?



Drawbacks

DADUs create greater housing diversity and provide many benefits to the city, communities, and inhabitants. However, the manner in which they are built and engage with surrounding context leaves much room for improvement. The catch 22 of allowing residents to develop residences is that they tend to lack architectural knowhow and planning foresight to create truly effective spaces. Many DADUs are built without careful analysis of site, context, and environment. These analyses present unique conditions and opportunities that can and should be explored.

Because each DADU is built by a different person with a different set of reasons, values, and criteria there is little to no chance of them working as a cohesive whole within the greater context of the built environment. Just as office buildings, apartment complexes, and a single-family homes have a greater collective social function as part of the city fabric so should DADUs. Although codes have created a framework in which DADUs can be constructed architecture and urban planning are integral to making healthy, efficient, and effective places.

Economic viability is disproportionately or entirely relied upon to drive construction of most DADUs. Potential for income generation leads many homeowners to build DADUs solely for the means of economic gain. Building under the pretext of maximizing profit manifests itself in the form of inexpensive stock materials, industry standard construction methods, and by-the-book detailing. The result is mundane structures that fail to celebrate the unique nature of this building type and associated lifestyle. The relatively low expense of building a small structure combined with its self-generating revenue provides the perfect opportunity to explore new, creative, and effective forms of building, material application, and system integration. Reinvesting in the construction and operation of DADUs has the potential to increase return by building something unique, functional, and desirable.

While DADUs do allow for greater opportunities for chance social interaction than high-rise units more often than not these exchanges do not occur due to the placement, orientation, and accessibility of the units. As code dictates DADUs are allowed only in backyards and are to be set back from all, usually fenced, lot lines. This means that any chance interactions are limited to the occupants of the DADU and the main house. The lack of connection and invisibility from street life can lead to a sense of alienation and isolation from the rest of the neighborhood.



Over one third of all DADUs built in Seattle are built on a lot with alley access. These structures can be built directly on the alley fronting lot line and are often built over existing or newly constructed garages and/or storage areas. Elevating dwelling units entirely above garages and storage areas creates a further sense of isolation and alienation by removing occupants from potential activity and interactions at the ground level. DADUs built at ground level on alleyways fail to engage, in any way, with the public right-of-way. Private dwellings turn their back on the public realm by orienting entrances towards the main house and building large blank walls facing the alleyway. Nothing in the code requires homeowners to engage with the public realm, nor are any incentives provided to do so.

The small scale of DADUs reduces footprint, site disturbance, and resource consumption. However, most do not strive beyond these intrinsic environmental benefits to explore the passive potentials associated with local climatic conditions. DADUs are at a more manageable scale for implementing the carbon neutrality of The 2030 Challenge, the high performance standards of Passivhaus, or off-the-grid operation. A smaller volume, envelope, and footprint means that even minor interventions can lead to large benefits. Environmental impact be further minimized or potentially eliminated altogether through the harnessing of resources, systems integration, and ecological site management.

Compact PV arrays can generate sufficient energy to handle reduced loads from mechanical and electrical systems. Rainwater can be harvested and used for greywater applications or purified for potable use. Natural ventilation can easily supply fresh air to open plan layouts with minimal heat loss. Because of the small volume, heat generated by occupants and appliances greatly reduces the loads on heating systems; loads that can be further offset by means of passive solar gain. Areas with good solar orientation can be used for food production, both outside and inside the home. Exterior spaces can be planted with native species to provide natural shading, screening, and to prevent erosion. Exterior hardscapes can be built using porous pavers which help sequester runoff and replenish the water table.

DADUs share aspects of both detached single-family homes and multi-family units but are functionally, contextually, and architecturally other. This unique and relatively unconventional building type should merit a special architectural approach. However, in the vast number of cases DADUs are built to the specifications of a single-family home and use standard construction, materials, and finishing. The paradigm of single-family homes is being forced onto an inherently different building type. The result is an architectural identity crisis which essentially amounts to an apartment unit dressed as a full-sized house placed in a backyard. Seattle guidelines for DADUs encourage owners to build in the existing styles of the neighborhood in order to minimize visual impact. This Disney-like miniaturization of residential paradigms results in bizarrely proportioned structures that attempt to recreate bygone architectural eras and styles.



In the most basic end of the DADU spectrum are conversions of existing garages into living units. The reuse of existing structures is the greenest form of building and is the best way to retain the existing fabric and character of a place. However, most garage to DADU conversions or additions result in Frankenstein-esque structures that are neither garage nor home. If original wood siding is kept it is 'matched' with Hardie Board or vinyl. Doors, windows, and access stairs are crudely cut into existing walls and thoughtlessly placed into new ones.

At the mid range of DADUs new structures are built with little or no architectural thought, constructed and finished using standard practices, and painted to match the main house. On the high end one can find additional costs being invested in the form of copulas that serve no function, exterior shutters that do not move let alone block sun, and plastic ginger breading. Occasionally a DADU is built that breaks from this pattern. Tall structures striving to minimize their built footprint, well oriented windows and overhangs to harness solar heat gain and maximize natural daylighting, and finishes that better reflect context and use, but unfortunately these are the exception to the norm.

For the most part DADUs are tucked away in backyards far from the eyes of the general public. For these only side and rear neighbors are able to see roofs or upper stories over fences or possibly a passerby getting a glimpse down a driveway. This is not the case with DADUs built on lots with alley access. These structures are clearly visible from the public right-of-way on which they are built. Unlike DADUs built on lots without alley access, alley lots have no setback requirements and thus can be built directly on the alley fronting lot line. This means that these private structures are allowed to define public space with no requirements on how to interface with the public realm.

Blank walls void of fenestration, entrances, or changes in depth shape 'alley walls' in the city. Nearly every DADU built on an alley lot has been built directly on, or within feet of, the alley fronting lot line. Not a single one of these DADUs has a primary entrance oriented towards the alleyway other than garage doors (in the case of additions/conversions). Unlike a backyard an alleyway is public property and homeowners should have a social obligation to engage alley accessible DADUs with the public realm. Disregarding the potential of residential alleyways as functional, social, and vibrant spaces is the greatest oversight of the current code allowing for the construction of DADUs on alley accessed lots.

"One of the great but often unmentioned causes of both happiness and misery is the quality of our environment."

Alain de Botton,
The Architecture of Happiness



V. RESIDENTIAL ALLEYWAYS

Back alleys provided a once necessary redundancy of access to residential homes. Their primary function was to provide out of sight access for the delivery of coal, ice, and removal of waste. These services were made obsolete with turn of the century modernization. During this time residential alleyways found new use thanks to the rise of the personal automobile. Prior to WWII alleys were commonplace in the creation of grid-based developments. It was during this time that the vast majority of residential plats in Seattle were established. The postwar rise of suburbia, white flight, and urban sprawl saw the demise of the residential alleyway as a functional part of the greater transportation network. The thinking at this time was that alleyways were dirty, unsafe, and undesirable places; a stigma which was only reinforced by their omission from new residential developments. These negative connotations often overshadow their functional and cultural significance to the built landscapes.

Residential alleys have an intimate quality of scale. Typically they are twelve feet wide, paved with exposed aggregate concrete, and open to main streets on both sides. The character of these alleys is dominated architecturally by modest vernacular garages and storage sheds that are usually no larger than the footprint of a car and no taller than nine or so feet. These structures are typically built directly on alley and neighboring lot lines often sharing a wall with another structure. The utilitarian function of these structures is reflected in their simple construction, material palate, and lack of decorative embellishments. Though many of these structures have similar form, scale, and function slight differences in orientation, age, material, and color means that each one has a distinct character that can be linked to the individual property and owner. The volumetric rhythm of these structures linked with fences creates a rich texture of materials, finishes, and orientation that defines the alley wall.

Residential alleyways provide a block-scale community open space that is individual to each block. These spaces link the informal backyards of single-family homes with a semi-public exterior 'commons' which is not found in blocks without alley access. Often gardens, workshops, play areas, studios, and homes of block residents line this informal edge and provide a life of activity and social interaction. These alleyways are meaningful sub-places where the expression of individuality strengthens the communal character. The versatility of alleyways to accept a range of uses shows promise that they can be adapted for other needs as well. Today the demand for density and sustainable growth has the potential to bolster the existing social and infrastructural landscape of these unique places.

"The back-alley has a great social significance as a protected interior neighborhood open space – as opposed to the exterior neighborhood spaces such as streetscapes, playgrounds and parks. Back-alleys provide a semi-public, intimate setting for casual social interactions which may not be possible in more formal, public settings such as street-facing front yards."

Michael David Martin,
Department of Landscape Architecture
Iowa State University





"Cities exist not for the passage of cars, but for the care and culture of human beings."

Lewis Mumford







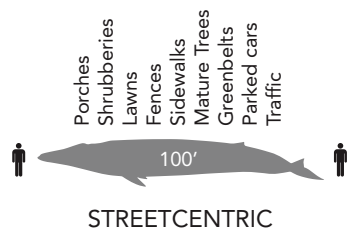
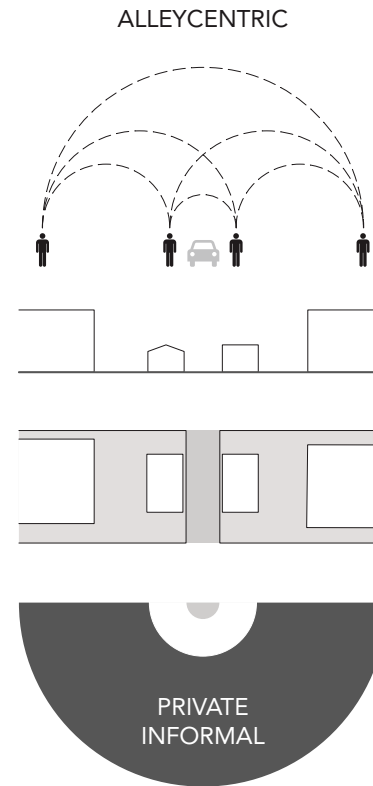
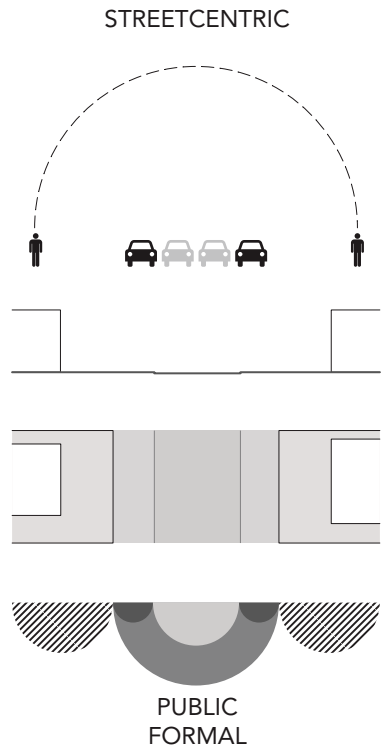





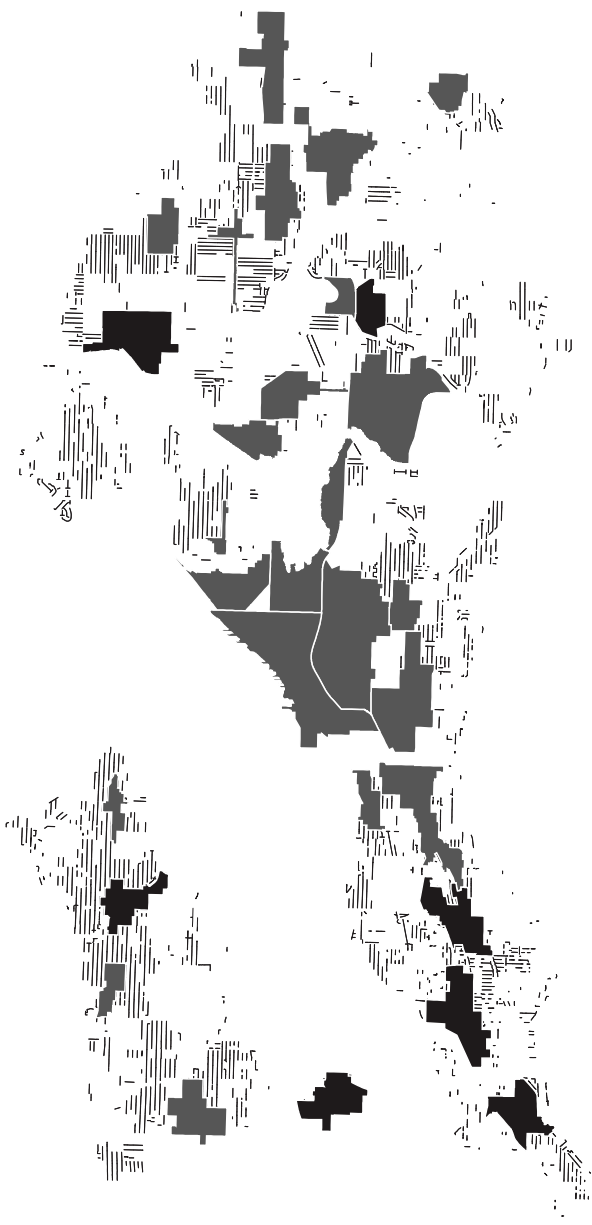

CROWN HILL

GREENWOOD
PHINNY RIDGE

AURORA
LICTON SPRINGS

GREENLAKE

ROOSEVELT

UNIVERSITY
COMMUNITY

Each of Seattle's Urban Villages has a single-family residential neighborhood in close proximity to it and in each of these neighborhoods there are clusters of residential alleyways. When the decision of how these tracts were to be laid down so was the decision of if they would have alley access or not. This means that alleyways are not spread evenly throughout the city but occur in dense clusters. One of the main ideas behind the success of Urban Villages is living, working, and socializing in denser clusters so that resources and amenities can be shared and used more efficiently. Alley clusters show the same potential of gaining this critical mass in their dense arrangement and proximity to urban cores.

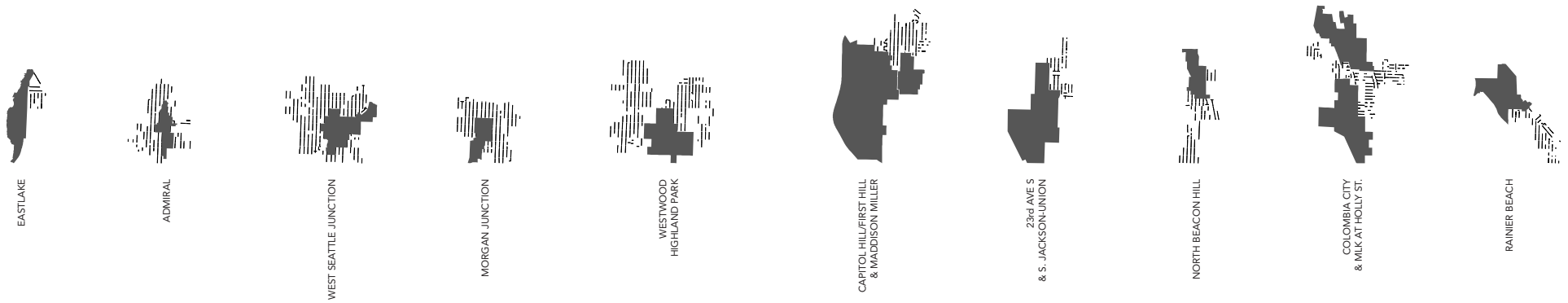

- Single-Family Residential
- Multi-Family Residential
- Commercial
- Industrial
- Major Institution
- Urban Village Overlay

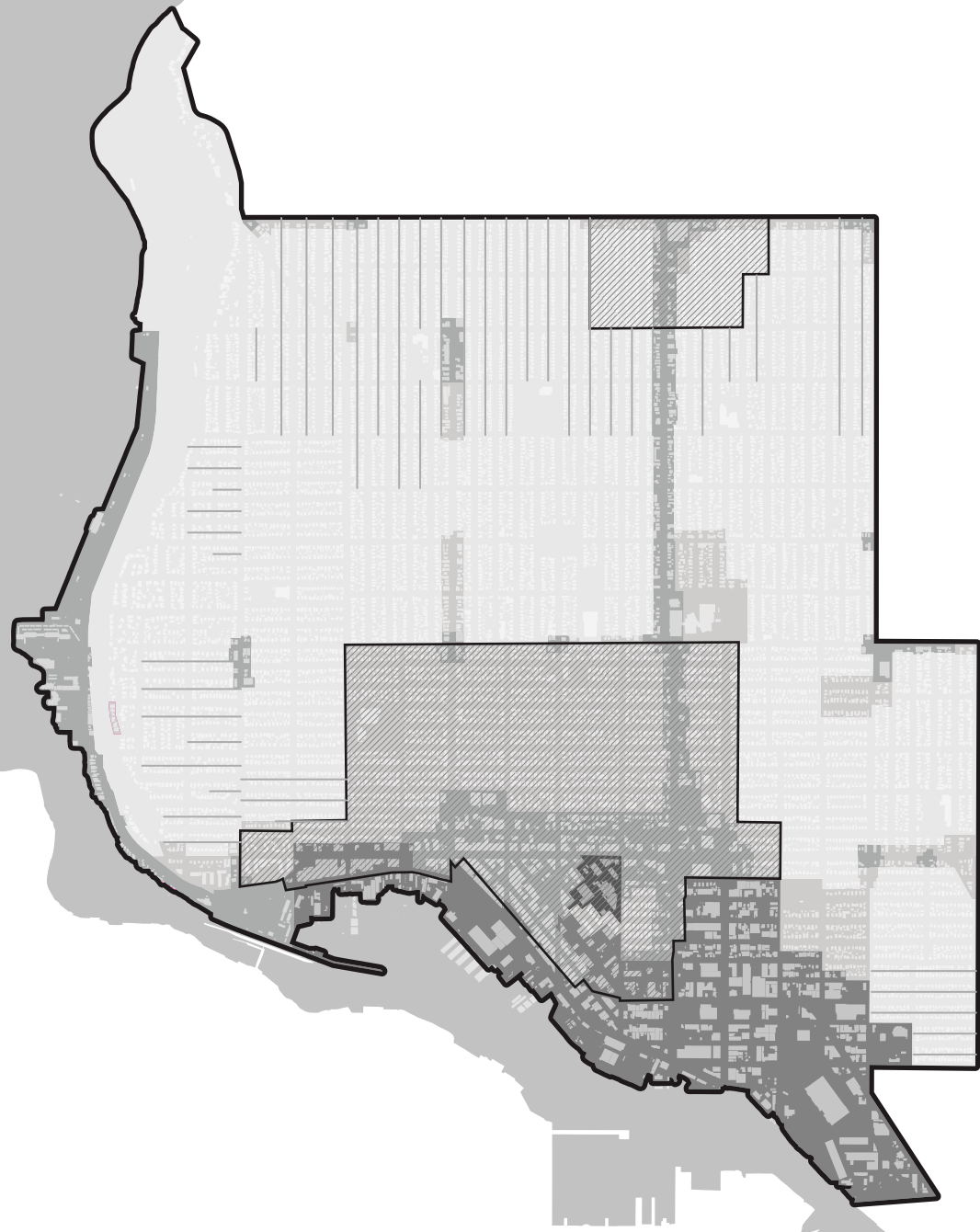

Ballard zoning

VI. CASE STUDY SITE

Ballard—A sleepy little drinking town with a BIG condo problem.

Ballard was chosen as a case study area to explore the potentials of DADUs for a number of reasons. It is the most tightly and diversely zoned areas of Seattle; over 75% percent of land uses are represented in this one neighborhood, there are two Urban Villages within its boundaries, it has at least three distinct residential alley clusters of varying size, location, and accessibility, and it has enough amenities that one can comfortably live within its borders. All of this and citizen outcry from developer driven densification makes Ballard a prime location to explore alternative forms of infill for the greater Seattle area.

Ballard is located in northwest Seattle just north of Salmon Bay and east of Shilshole Bay. Founded in 1889 and incorporated in 1890 Ballard highlights Seattle's industrial and residential growth patterns. Primarily based on timber, fisheries and foundries Ballard once boasted the largest shingle mill in the world. This blue collar area was primarily settled by immigrant workers from Scandinavia who came to work in the fisheries and mills. This strong Scandinavian influence can still be seen today and is an important cultural and historical identity of the area. In 1907, much to the chagrin of local residents, Ballard was annexed by the city of Seattle. One of the highlights of downtown Ballard is Ballard Ave which is one of Seattle's 37 recognized historic places.

Downtown Ballard is situated on a triangular piece of land in between the industrial waterfront to the south and the single-family neighborhoods to the north. In recent years the area surrounding downtown Ballard has undergone a large transformation. The creation of the Ballard Hub Urban Village made possible the creation of high-density, multi-use and multi-family dwelling units in former commercial, residential, and light industrial zoned areas. The increase in density of this area was needed as the popularity of Ballard grew; however, it was the manifestation of this density increase in the form of high-rise condominiums that destroyed much of the human scale and character that initially made the area desirable.



Ballard centers, transportation, and alley clusters

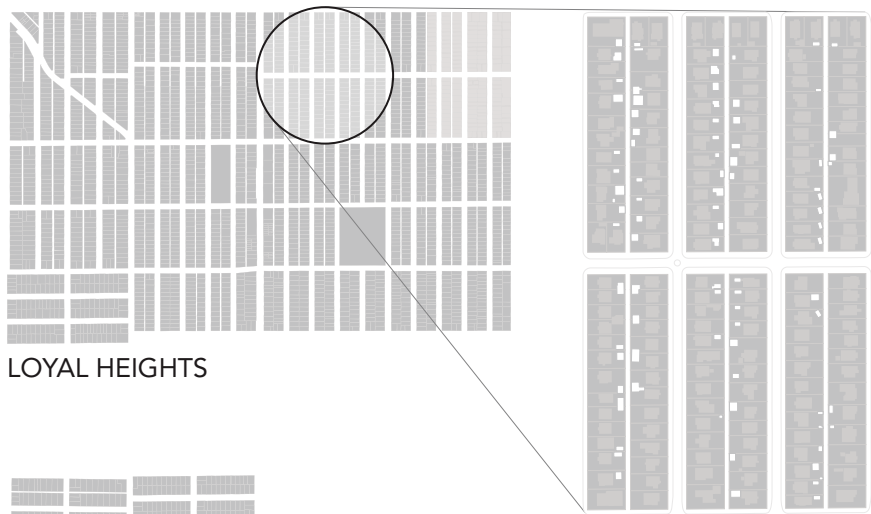

160 Lots
107 Alley Structures

USES
34 Parking
61 Storage
04 Dwelling
04 Workshop
01 Boat/RV
03 Multi-Use

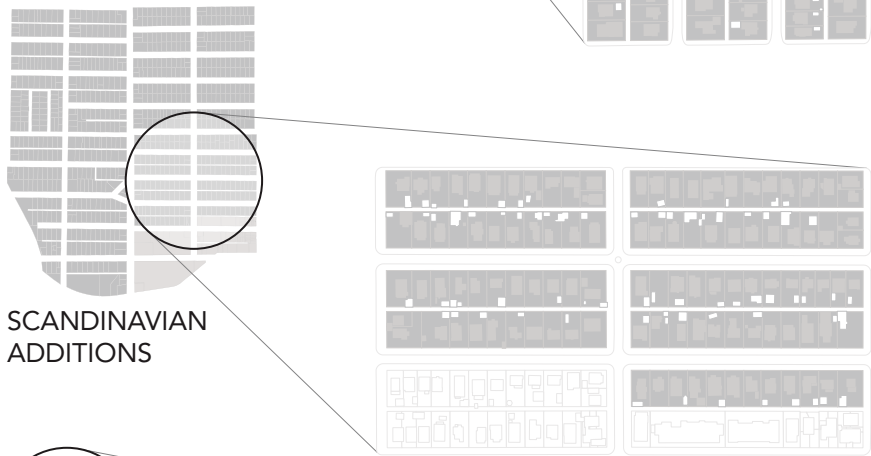
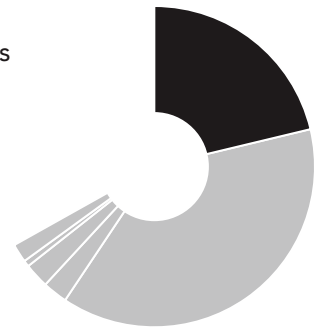

104 Lots
60 Alley Structures

USES
07 Parking
40 Storage
05 Dwelling
04 Workshop
03 Boat/RV
01 Multi-Use

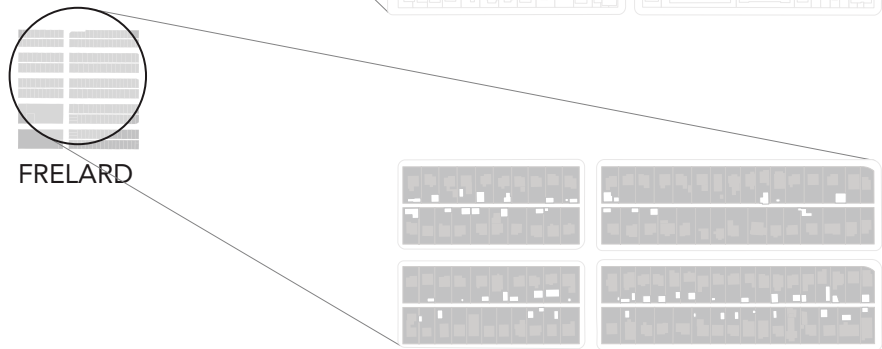
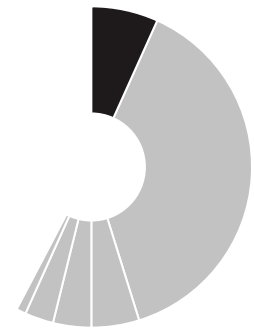

105 Lots
53 Alley Structures

USES
16 Parking
28 Storage
03 Dwelling
03 Workshop
02 Boat/RV
01 Multi-Use





VII. AN ETHIC OF DEVELOPMENT

Too often code is treated as a standard for development rather than a baseline to improve upon. Code dictates what can be built not what should be built nor how it should be built. It is left up to architects, builders, and developers to include economic, social, and environmental strategies to their designs. Unfortunately, often these elements are not included because they are not required. This design strategy looks beyond baseline requirements in an attempt to create an ethic of development that combines economic, social, and environmental standpoints into a holistic approach in order to yield a higher quality of built fabric.

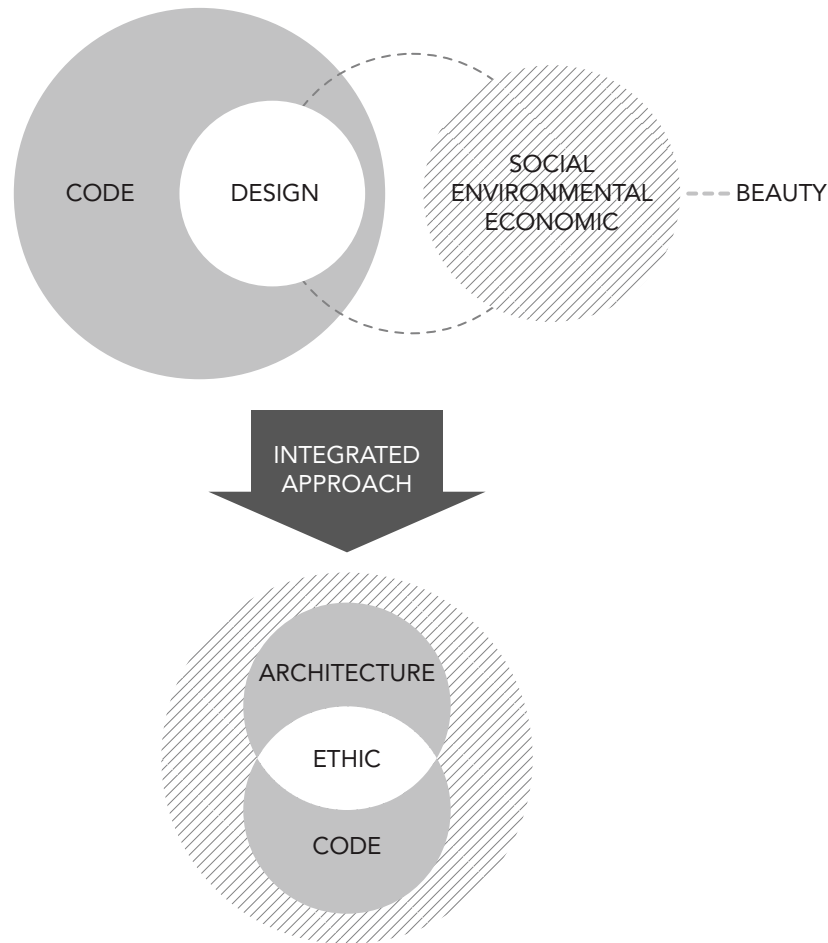

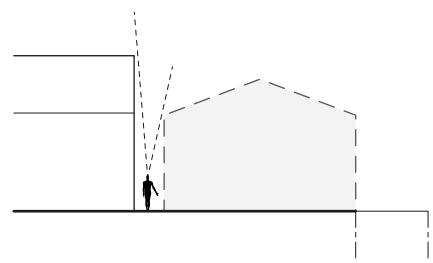
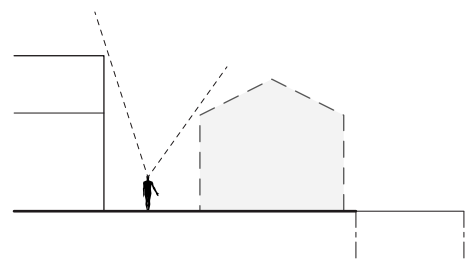
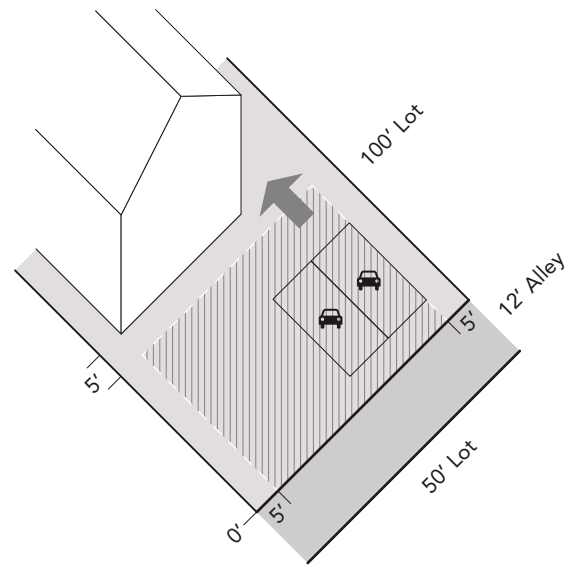
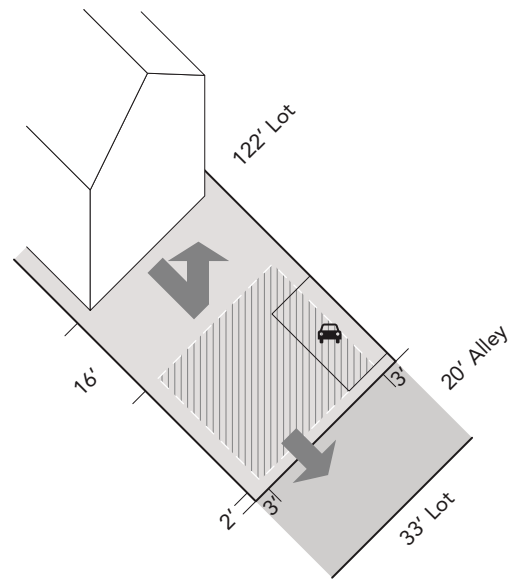
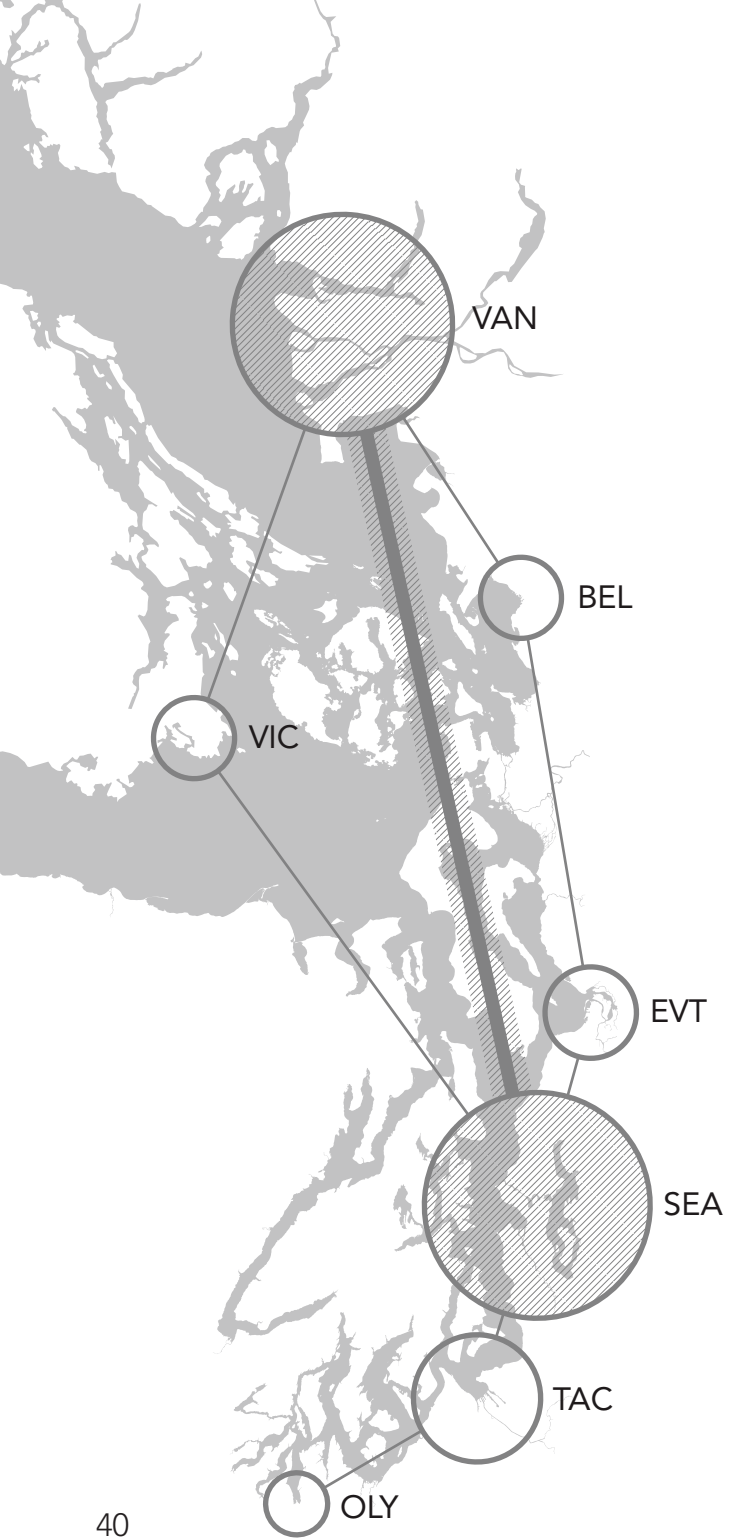

Code

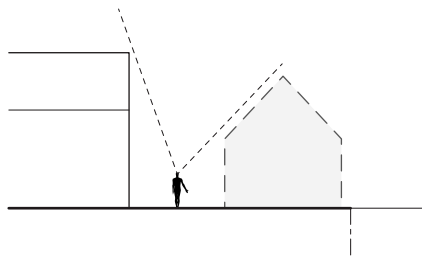
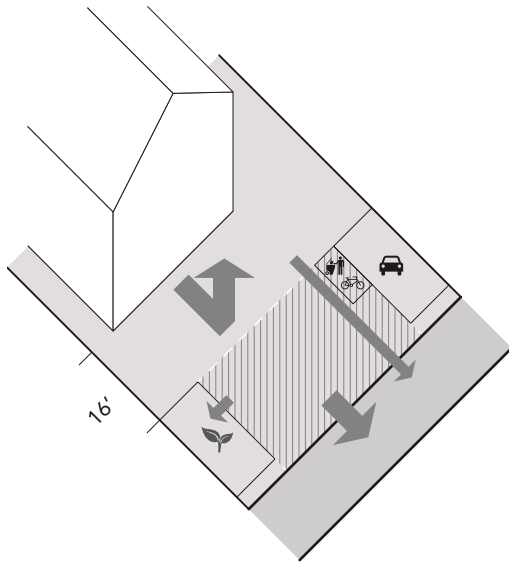

Code overlay

The Laneway Houses of Vancouver, BC are successful examples of developing public right-of-ways with small scale dwellings. What is different about the way such dwellings are realized in Vancouver versus Seattle? First off, how the two cities were platted is quite different. In Vancouver the average size of a single-family lot is 33' wide by 122' deep compared with Seattle's 50' by 100' lots. Another striking difference, and reason why Laneway Houses were specifically targeted in Vancouver is that 95% of all lots in Vancouver have alley access as opposed to only 35% in Seattle. The right-of-way too is larger in Vancouver at an average width of 20' compared with 12' in Seattle. These physical differences do have a role to play in how the two cities approach this form of infill but it is in the code where some of the greatest differences occur.

In both cities DADUs are looked at as a way to increase housing diversity, affordability, and homeowner opportunity. However, when expanding on the guiding principles of the benefits of DADUs one sees that in Vancouver, the Laneway House are ways to achieve lane enhancement, livability, neighborliness, and green design. In Seattle the reasons to build are better housing maintenance, housing extended family, increased property value, and additional income from rent. Right there in the government issued guidelines we see the difference between building for social benefit and individual gain.

This difference is further expressed in the code for the construction of DADUs in Vancouver and Seattle. The main differences are a 3' setback from all property lines and a 16' setback from the main house in Vancouver compared to a 5' setback from neighboring property lines and from the main house with a 0' setback from the alley fronting lot line. Vancouver code requires one exterior parking space that is to be covered with porous pavers while Seattle has a requirement of at least two spaces, covered or not. And finally in Vancouver entrances, openings, and green spaces must front the alleyway. There is no such requirement in Seattle.

Each requirement in Vancouver promotes socially engaging dwellings that preserve privacy, views, access to daylight, outdoor green space, and reduce impervious surfaces. The quality of DADUs built in Vancouver reflects this social obligation in that each Laneway Home is built as if it were its own home that adds in a positive way to its surrounding context. In Seattle the Backyard Cottage too often manifests the individuals drive for economic gain, all of which is allowed by code.

If Vancouver code is a baseline for successful development what would happen if their code were used as a means of improving code in Seattle? We can see the benefits of code in Vancouver so if it were to be implemented in Seattle what would be the differences? The main changes that would occur would be orienting the DADU towards the alley, reduce the overall massing, increase the setback from the main house, reduce the setback from neighboring lots, and reduce the on-site parking requirements from two to one. All of these changes increase open green space, access to daylight and views, and most importantly create conditions which are conducive to social interactions amongst neighbors.

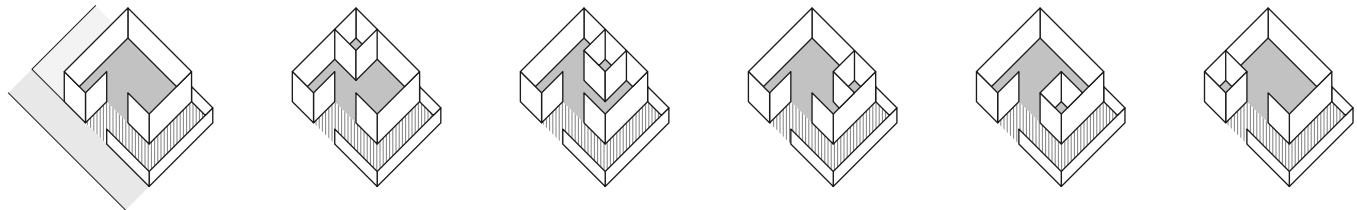
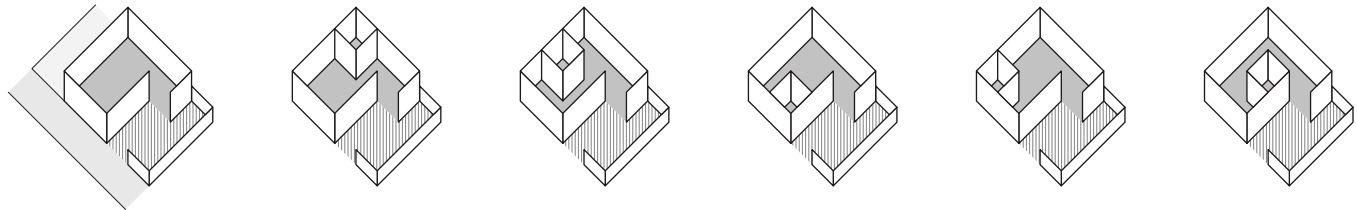
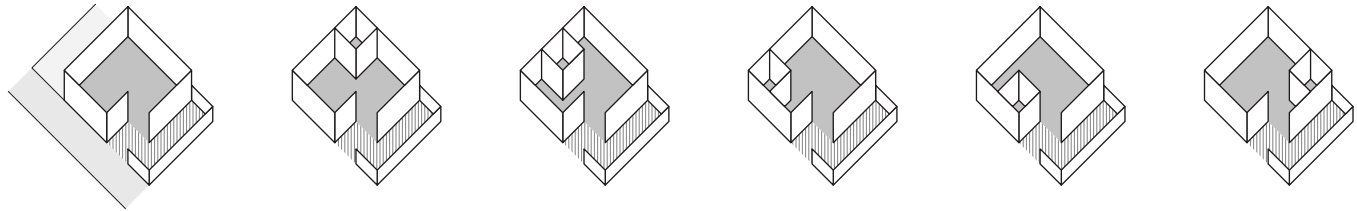
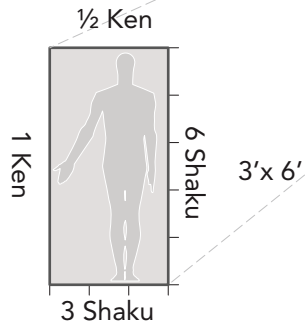
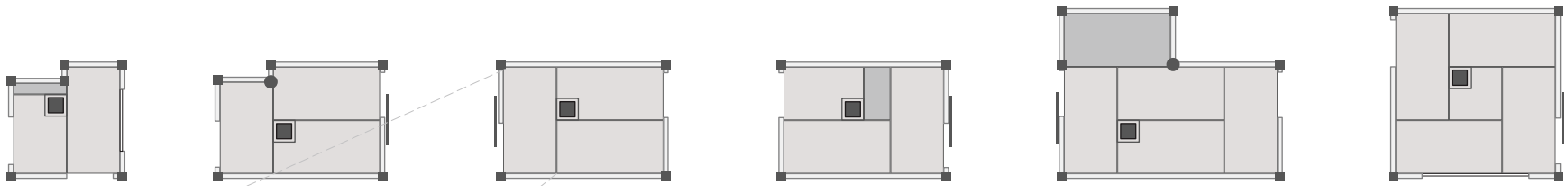

Site Relationship

The typical single-family lot in Seattle is 50' wide by 100' deep. This means that along this 50' place for exterior parking, open space, and dwelling must be placed. Exterior space for parking and green space are placed along the adjoining property lines in order to maximize usable space that would otherwise be lost to setbacks. This created a condition where the DADU would be placed in a central location on the site. The length of the DADU was maximized to create a notable presence on the alley and to create the chance to narrow the dwelling in order to preserve as much exterior space for the main house as possible.

The green space is placed on the south side of the lot to maximize on solar orientation while the parking, garbage, and bike storage is placed in the shaded northern side of the lot. Porous pavers are used for the exterior parking hardscape in order to bring the alley into the property while still maintaining the green exterior feeling of the backyard. The green space of the DADU adjoins the backyard of the main house which can be combined or partitioned off for privacy. This allows the DADU to act as sort of a living fence; having a presence along the parking, green space, backyard, and alley.

The DADU has a unique relationship with its surroundings in that it interfaces with the public alleyway, private backyard, and personal exterior spaces. Because of this it is important to allow the internal spaces to react and interact with its unique combination and orientation of exterior spaces. By using a modular design that is inspired by the tatami mat different orientations and configurations yield different relationships and spatial layouts between inside and out. The addition of a solid water element to the interior creates an even greater variety of interior layouts which then in turn affect the relationship of interior and exterior spaces. Because the overall plan is based on a modular unit the shifting of interior and exterior layouts does not greatly affect the construction or amount of space the unit takes up. This allows for a freedom of layouts that can respond to unique site conditions and the needs and desires of the individual building the DADU.

"The builders of traditional societies shaped their buildings with their own bodies in the same way that a bird molds its nest by its body. The essence of a tradition is the wisdom of the body stored in the haptic memory."

Juhani Pallasmaa,
Questions of Perception

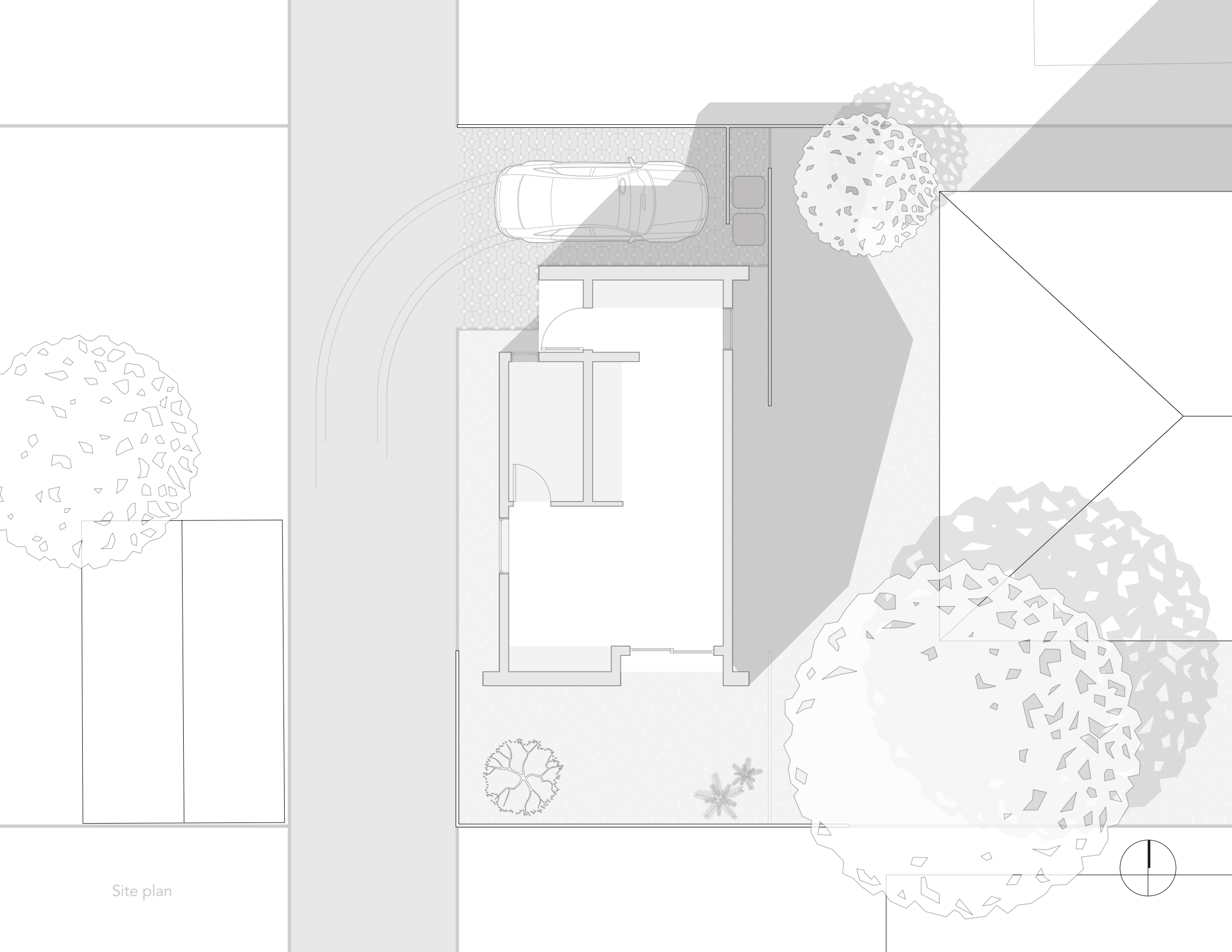

Site plan

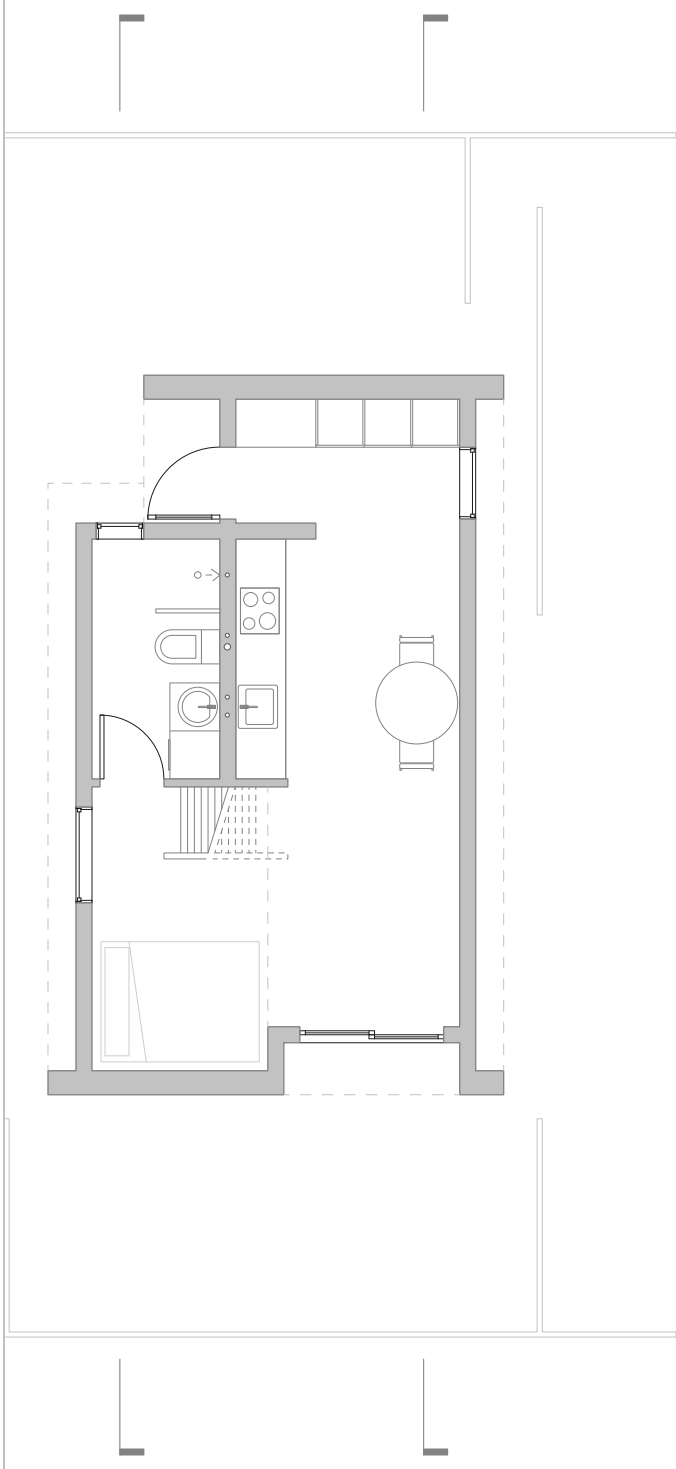

Plans

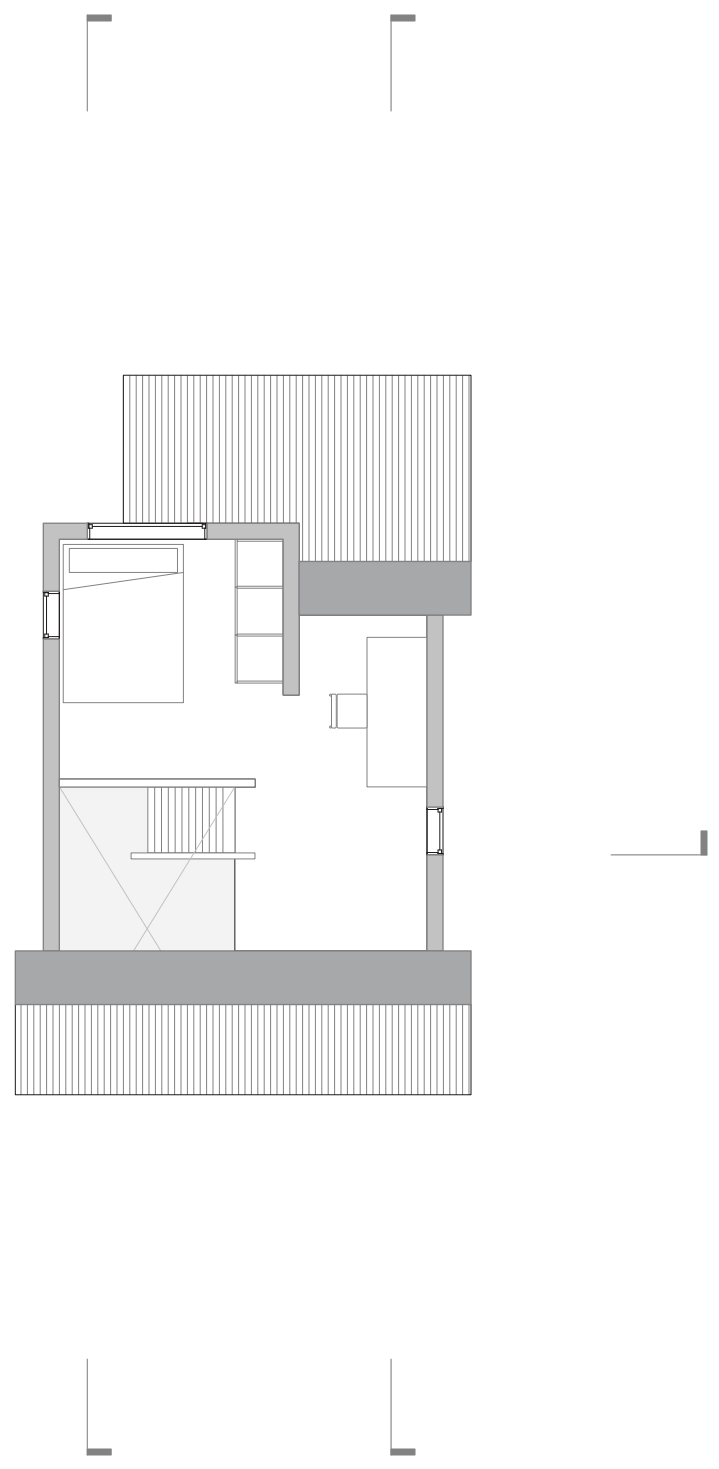

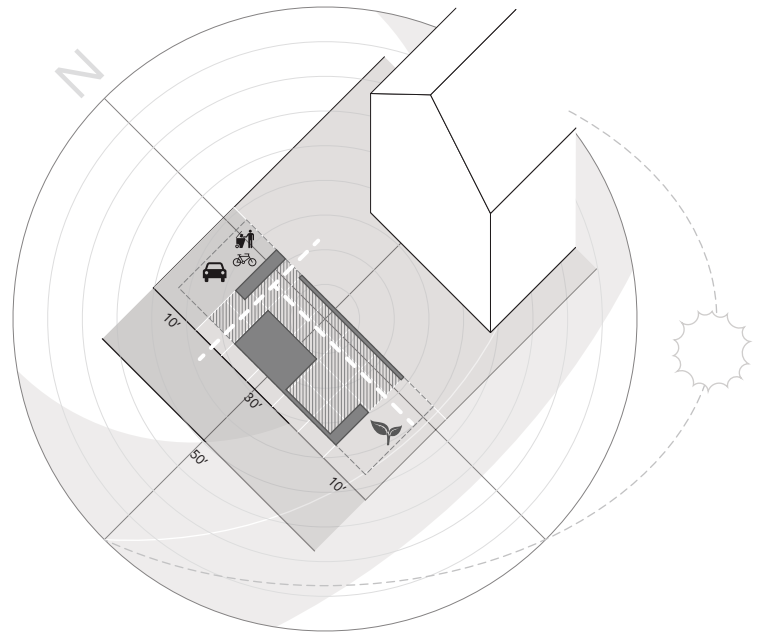
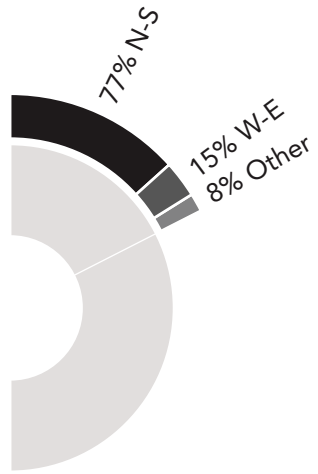

Orientation

The orientation of the alley is one of the most important factors when considering design from a solar perspective. Not only does it affect openings for daylight, entrances, and placement of outdoor spaces but it is also extremely important when considering access to views and daylight for existing structures and outdoor space. For example, a DADU built on the north or south side of a west to east alley will have vastly different relationships to openings for solar access, public spaces, private spaces, shadows cast, and shadows received. In the case of DADUs built on either side of north to south alleys openings for solar access and their relationship to entrances, open spaces, public, and private areas remains consistent. In Seattle 77% of alleyways are oriented north-south, 15% are west-east, and the remaining 8% have some other orientation. Looking at the north-south condition will be applicable to over three quarters of alley accessible lots in Seattle.

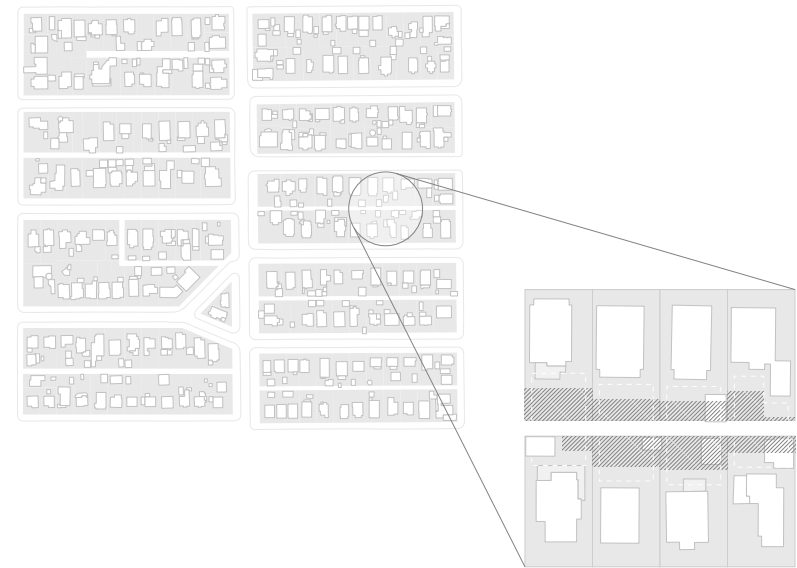
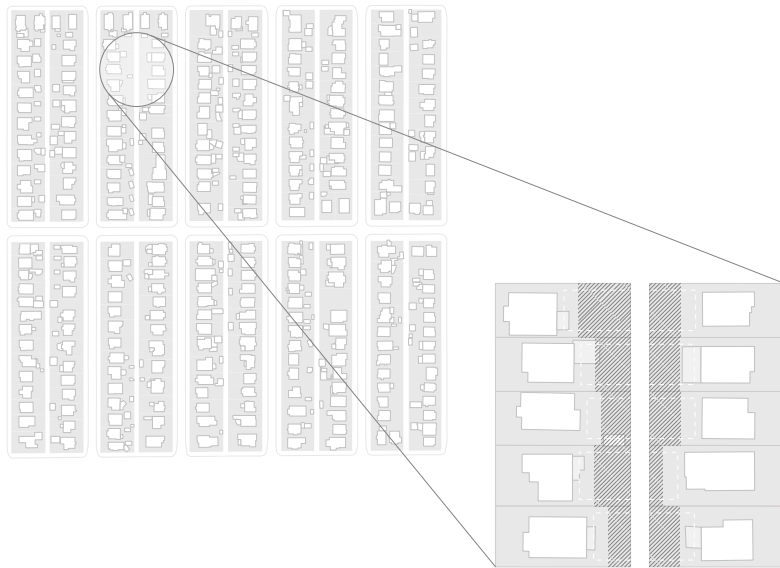

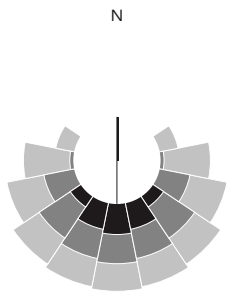

SUN ANGLE
 ● Winter Solstice
 ● Equinox
 ● Summer Solstice



WIND
 ● 0-7 Knots
 ● 7-11 Knots
 ● 11+ Knots

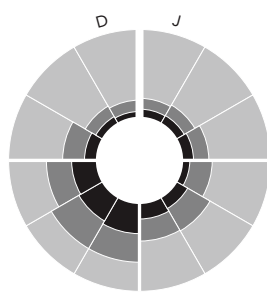

SKY COVER
 ● Clear
 ● Partly Cloudy
 ● Cloudy

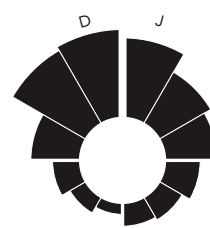

PRECIPITATION

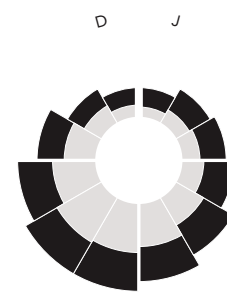

TEMPERATURE

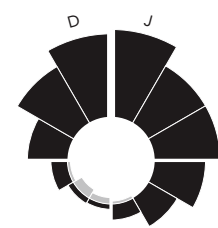

NORMAL DEGREE DAYS
 ● Heating (Base 65°)
 ● Cooling (Base 65°)

Climate

The Pacific Northwest is defined by its nature. The area's unique geography is what gives Seattle its characteristic weather. The city is located in the rain shadow of the Cascades, in the convergence zone behind the Olympics, and between two large bodies of water. All this leads to 152 days of precipitation, 201 cloudy days, and 93 partly cloudy days. The frequency of overcast days gives the region a filtered source of evenly distributed light void of strong shadows. The temperate climate of cool rainy winters and warm mostly sunny summers is complimented by seasonal daylight shifts ranging from eight hours on the winter solstice to sixteen hours on the summer solstice.

Architecture of the Pacific Northwest must respond to these unique conditions. This climate is dominated by heating degree days which requires ample insulation and a tight envelope in order to prevent heat loss. Designs must also provide ample shading for the long days of direct summer sun and heat. Apertures and fenestration must take into consideration the shifting qualities of daylight: short days of low angle sun in the winter, long days of high angle sun in the summer, and diffused daylight on overcast days. A hallmark of the Northwest climate is rain. Structures must not only be able to adequately shed precipitation but allow for natural airflow in order to adequately dry cavities to prevent moisture buildup and mold.

In this region the weather comes from the south. Here, southern façades have the greatest potential to interface with and harness wind, rain, and sun. Large openings create opportunities for controlled natural light and ventilation. Angling the roof towards the south creates prime condition for systems that harness solar energy such as photovoltaics and solar water heating. Peeling up the roof along this façade allows for vaulted interior spaces which create a stack effect and exterior negative pressure which further assist in creating natural airflow inside. Treating south facing façades with roofing material and insulation further mitigates the environmental bombardment that these faces consistently receive.

"Human life is not viable and human health is not possible without manifold free services provided by the Earth. The Earth receives sunlight, cleanses water, makes oxygen and grows plants that feed humans and other animals. Humans evolved outdoors, immersed in natural vegetated habitats and exposed to sunlight, fresh air, and water. Biophilia is the name given to the human love of nature based on this intrinsic interdependence between humans and other living systems."

Douglas Farr,
Sustainable Urbanism

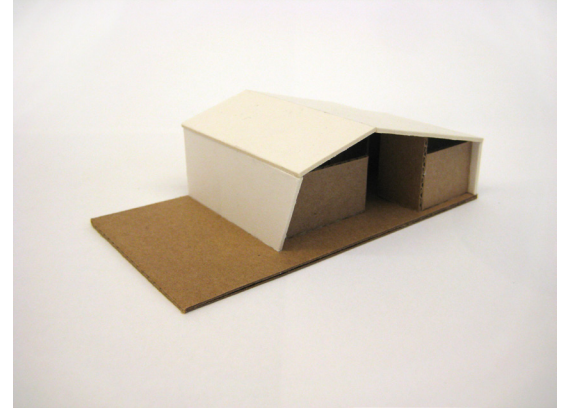
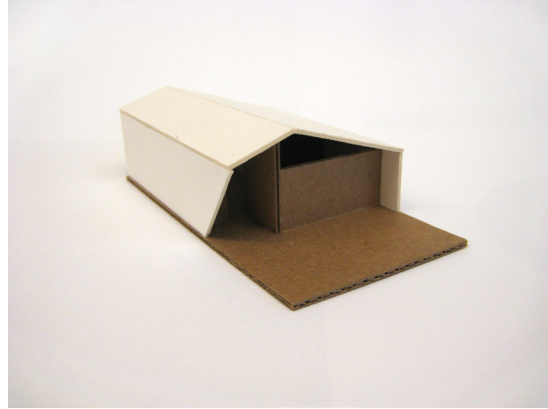
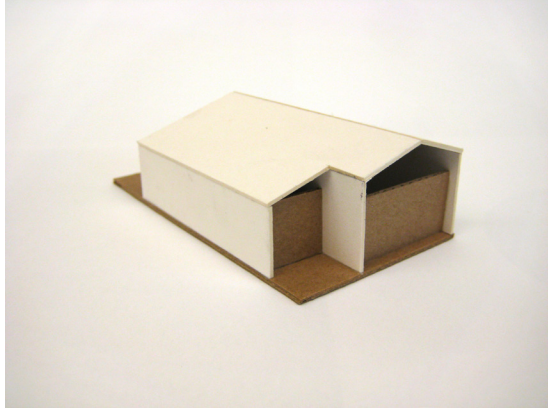

VIII. DESIGN

Environmental factors should be taken into great consideration when designing in this region. The roof acts as the greatest mediator between the elements and the habitation. It collects, protects, shades, sheds, and insulates from the heat, rain, wind, and sun. Due to this important relationship with the elements the roof was approached and viewed as being a major factor of the architectural design. Not only does it define the boundary between indoors and out but it can also be used to shape space; peeling back to define boundaries between rooms, carved away to create connections with the outdoors and daylight, and lifting up to create interior volumes.

The roof was explored both as a shaper of space and as an expressive structural and architectural element. Bringing the roof down to the foundation allows for a continuous plane of durable material to be used, especially on south facing façades. This not only creates extra protection from the elements but the thicker structure also provides additional insulation. Many variations of orientation, openings, and height were explored to find ways in which the character and function of the roof changes when defines a single story, multi-story, or partial story dwelling. In most cases steep pitches were used in order to maximize interior height, preserve daylight and views of neighboring structures, and to minimize the vertical use of roofing elements.

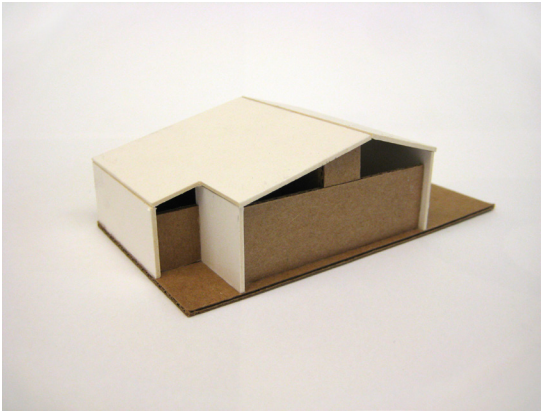

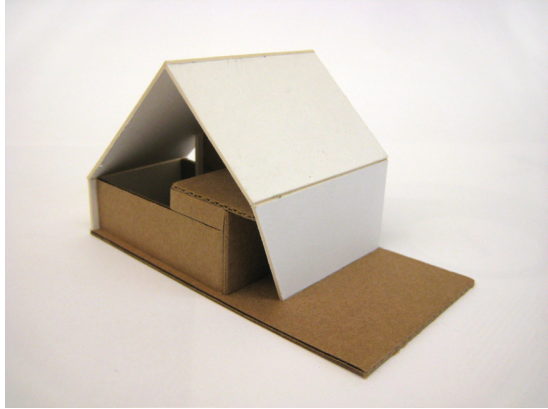

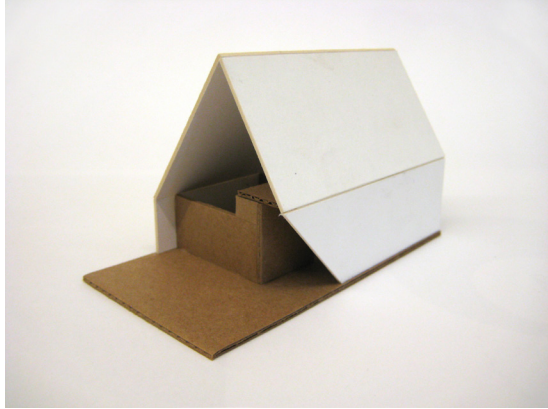

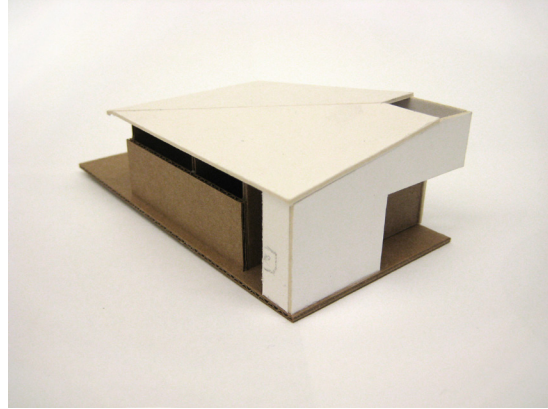
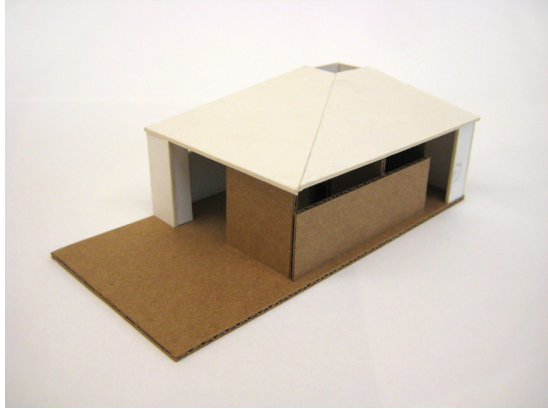

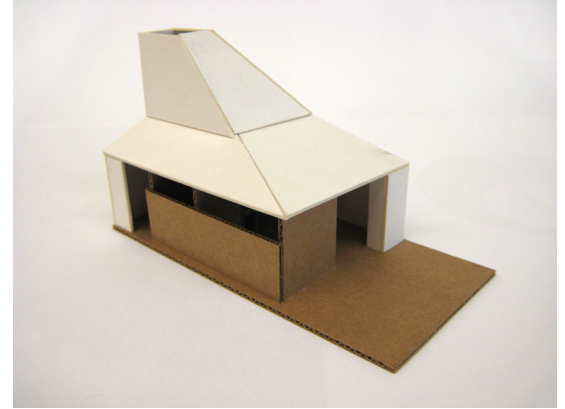
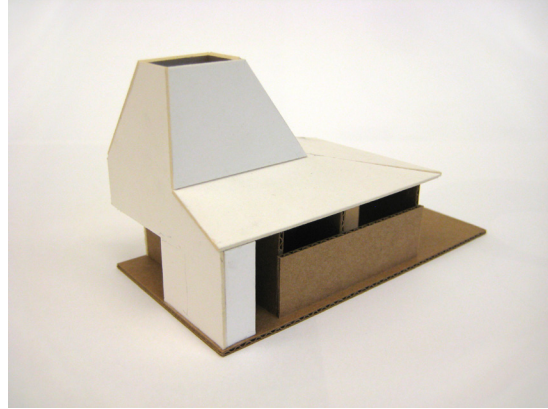

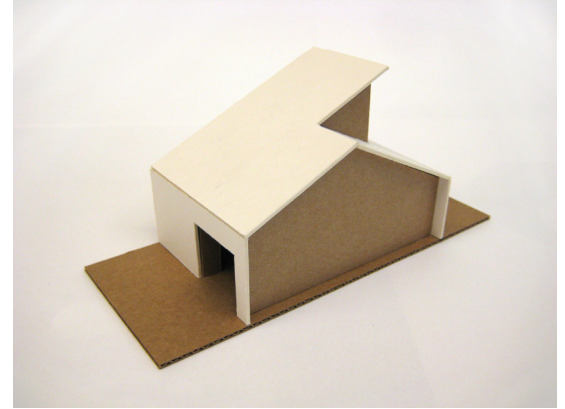
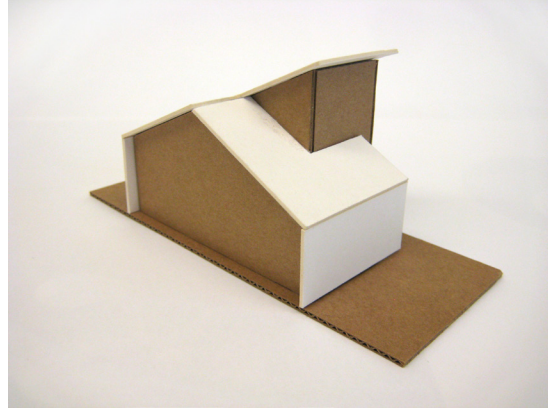
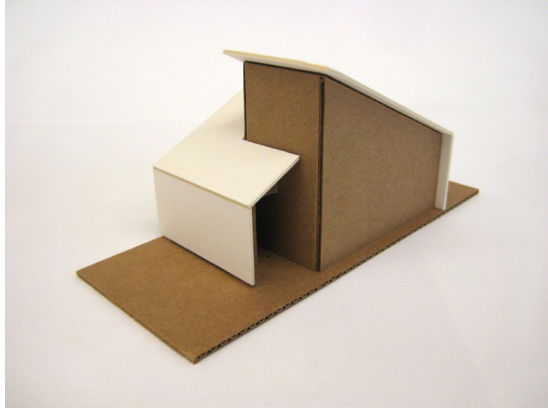

Ultimately a single direction was chosen in order to test the design principals, detailing, and materiality on a micro level. This design, based on a north-south orientation, uses a roof that is wrapped around the dwelling from the north to the south. This configuration was chosen for a number of reasons. Firstly, by sloping the roof and exposing the bulk of its surface to the south the maximum area is exposed to external forces and resources. This creates a condition where the most durable surfaces are exposed to the harshest climatic conditions. By carving a large portion away for glass doors controlled daylight, passive solar gain, and connection to the outdoor green space are brought into the dwelling. By breaking the ridgeline of the roof a large portion along the alley side is allowed to soar upwards creating high spaces in the loft area and creating opportunity to open up the façade to north light and passive stack ventilation. The remaining portion of the roof that slopes back down to the north captures the entrance area and provides visual and audible protection from the parking area.

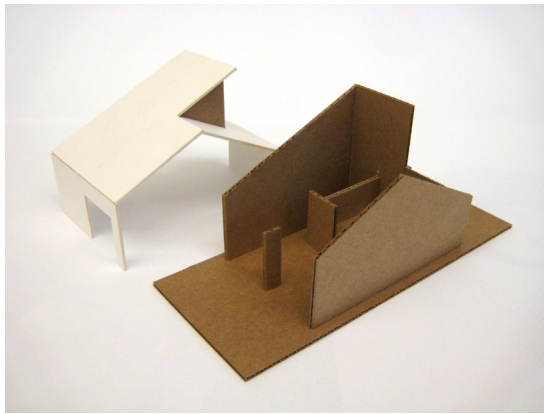

By wrapping the roof parallel to the alley and breaking the ridgeline maximum façade presence is given to the alley side and minimum vertical façade facing the main house. Pulling back the vaulted façade and sloping down the north roof plane creates a condition where the highest elements are pulled back and lower elements are brought closer to the neighboring lot line. This minimizes shading to neighboring sites, especially during the low sun angle winter months when solar access is needed the most. Bringing the roof to the ground on both the north and south sides allows for the east and west facades (alley or main house facing) to be treated in unique or possibly autonomous ways. Having a maximum customizable façade along the alleyway allows the dwelling to have a presence and individual character along the alley.

The sill height of fenestration along the alleyway is kept higher than other windows, at about four and a half feet. This allows visual access both into and out of the dwelling but still provides privacy from neighbors at a seated height. Openings facing the main house are kept to a minimum to maintain privacy while large openings to the outdoor green space and north facing loft area provide ample daylight, views, and natural cross ventilation. The main entrance is pulled back from the alley to create a space of privacy and repose. It too can be used for access to daylight and ventilation as it opens onto the main storage area which blocks direct visual access to living spaces from the alleyway.

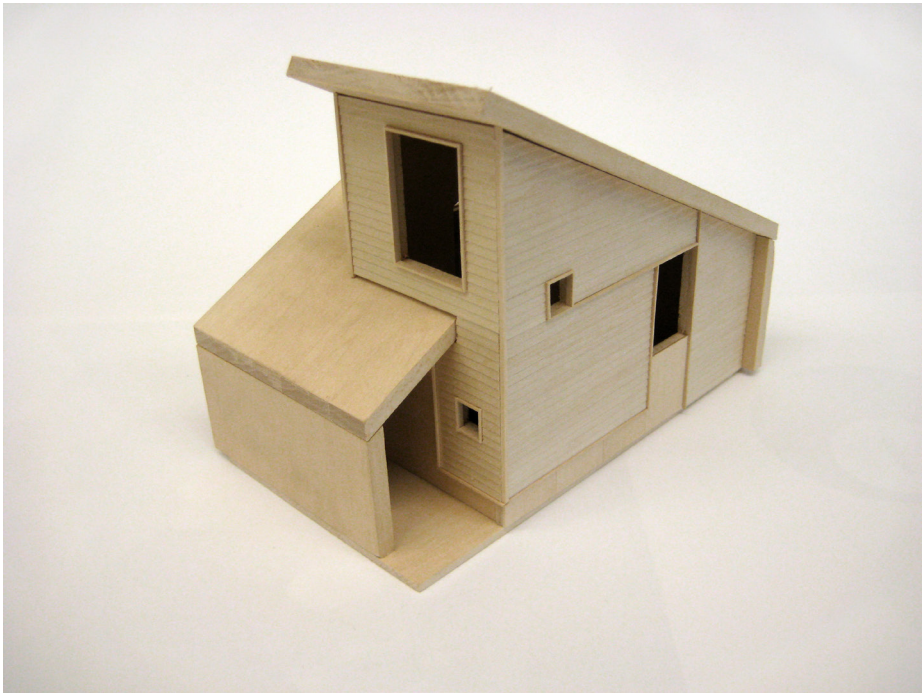



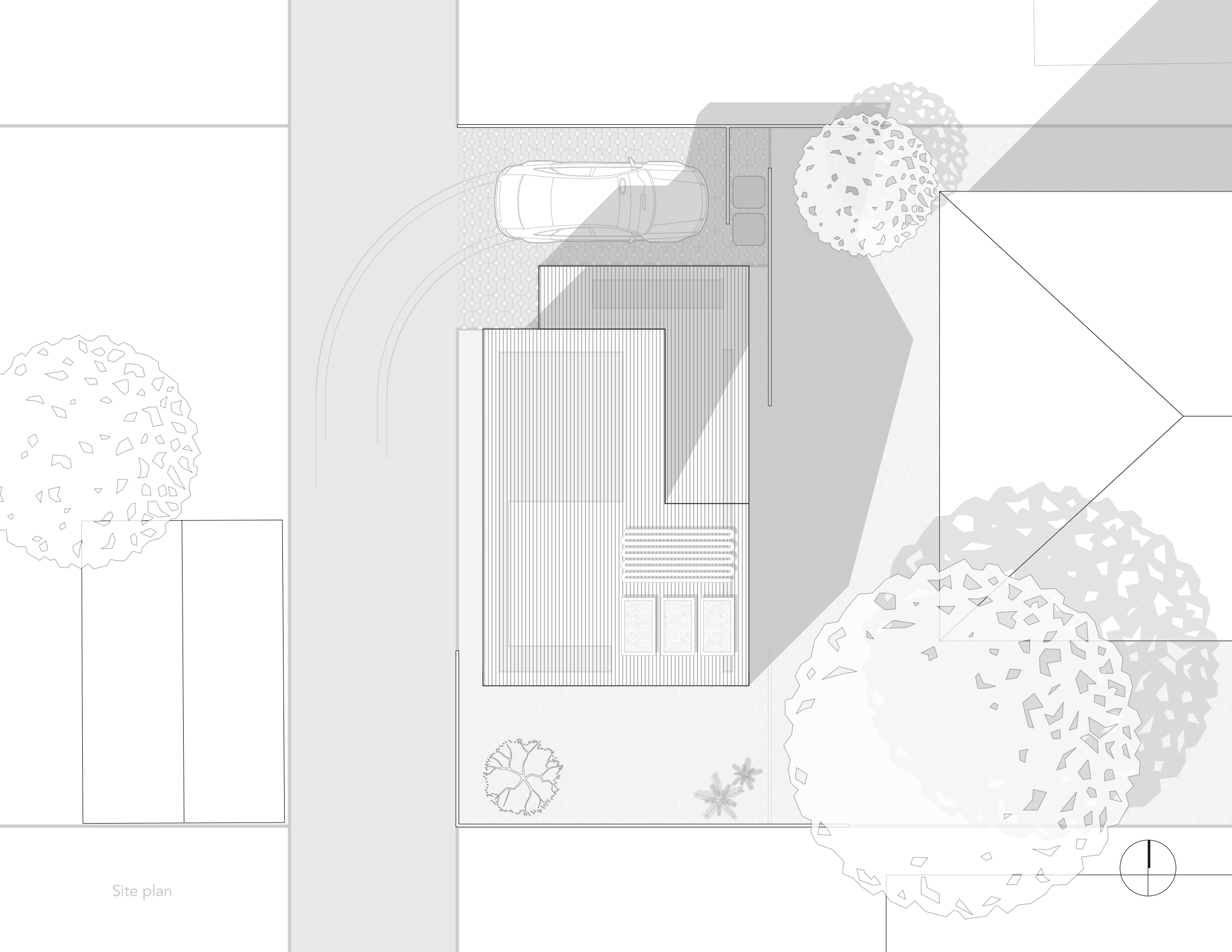

Site plan

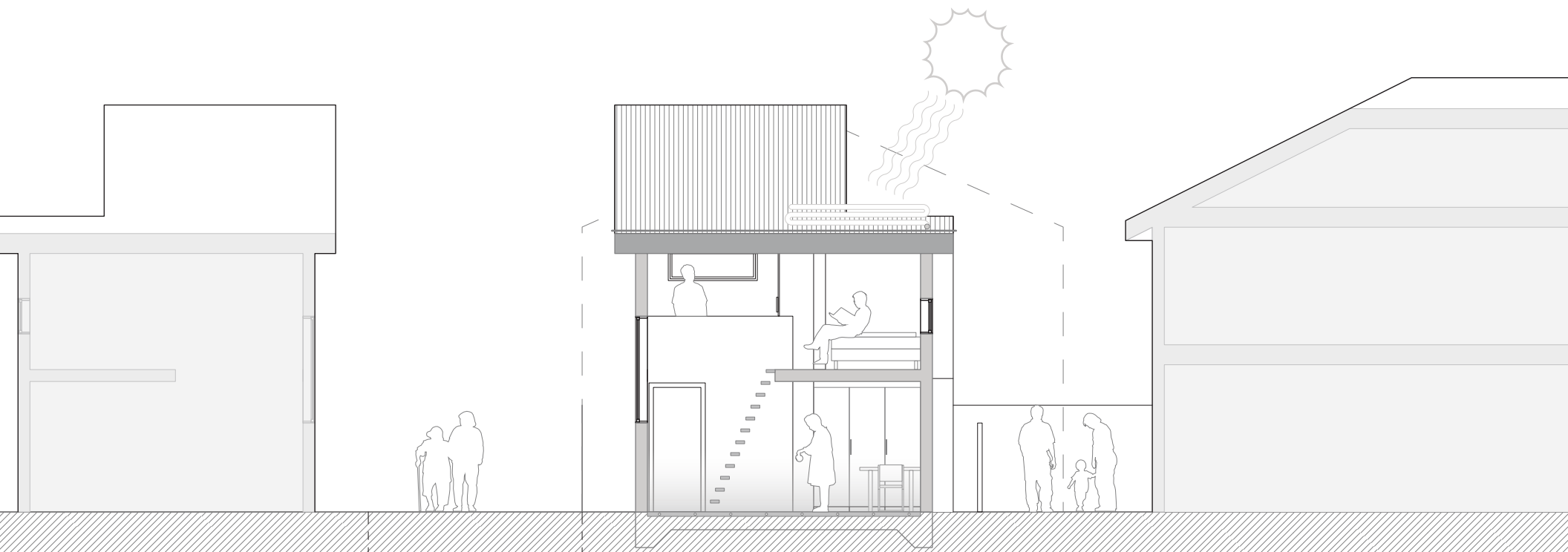

Transverse Section and radiant heating

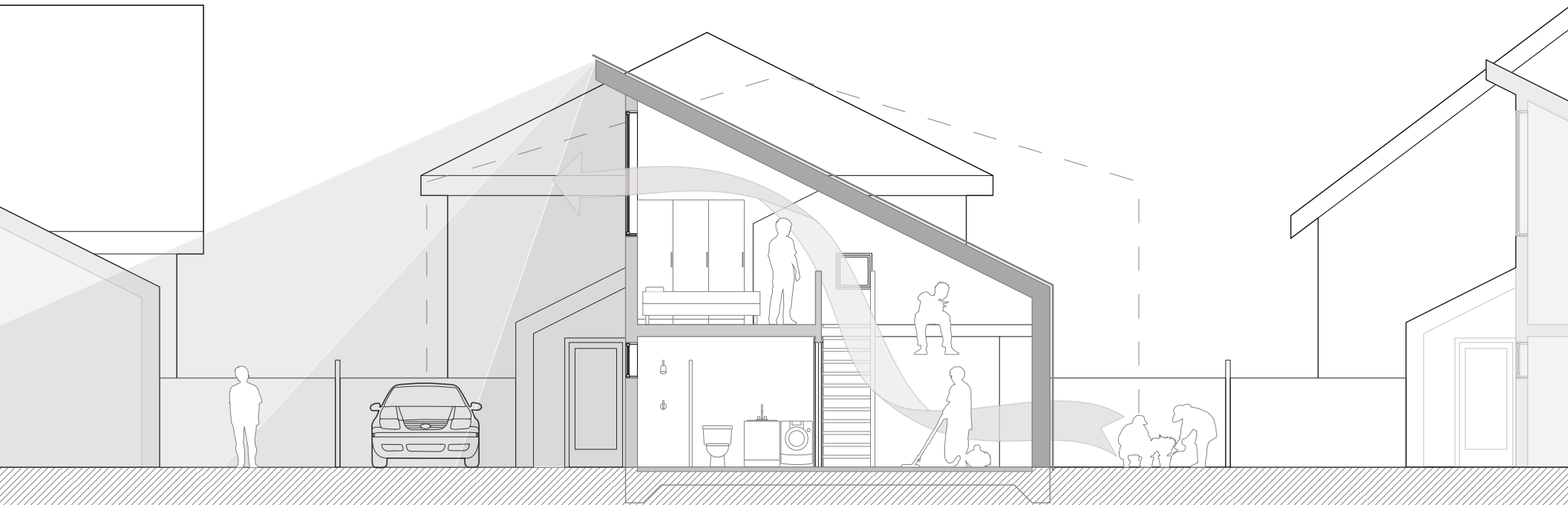

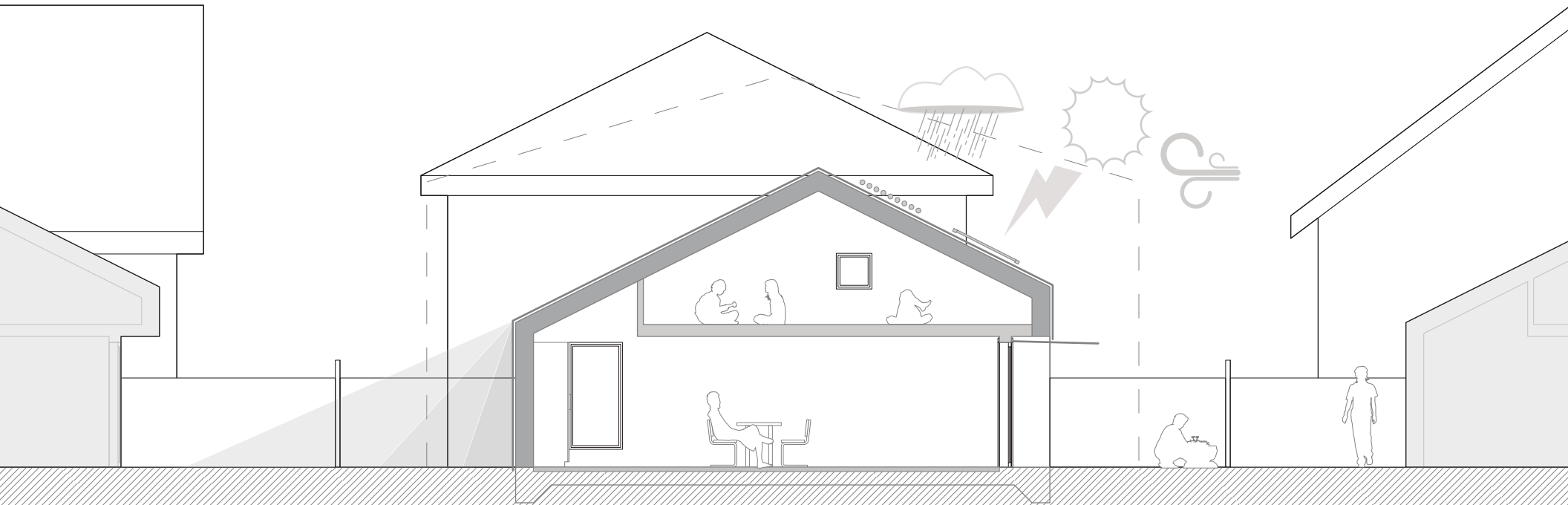

Longitudinal section and resource harnessing

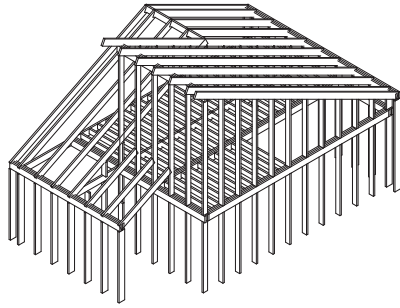

STICK BUILT

Benefits

- Familiar Construction
- Small Members
- Universally Available

Drawbacks

- Time Consuming
- Site Built
- Material Waste

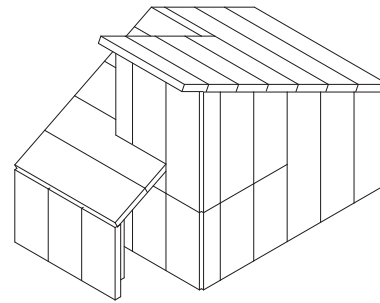

SIPS

Benefits

- Fast Assembly
- Tight Envelope
- High Insulation

Drawbacks

- Special Knowledge Needed
- Limited Availability
- Higher Cost

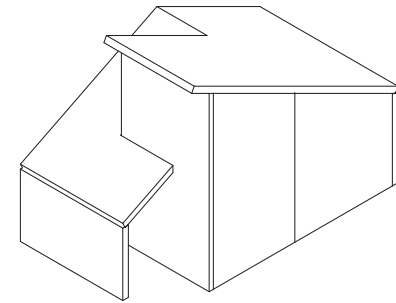

CLT

Benefits

- Single Material
- Structure/Finish/Insulation
- Quick Assembly

Drawbacks

- Very Limited Availability
- Technical Skillset Needed
- Highly Expensive Currently

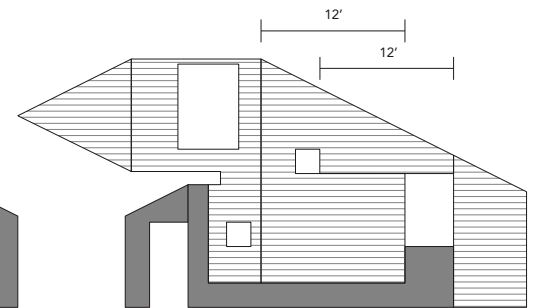
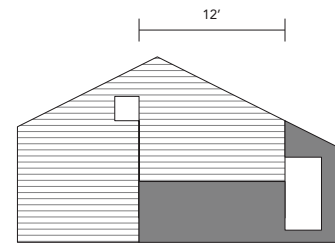
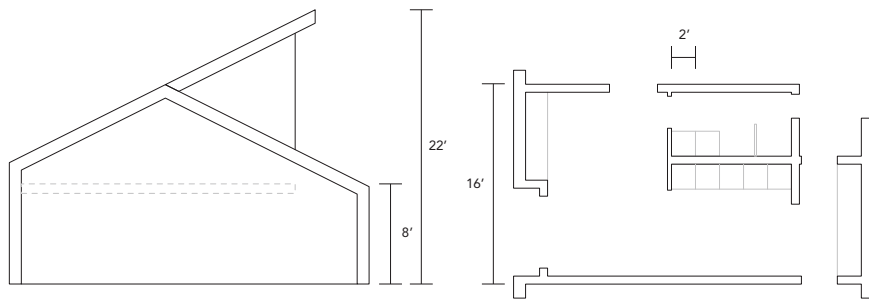

Construction

Construction and materiality are a major factors in keeping these small dwellings economic viable. Many factors, such as labor, longevity, availability, and finishing are factored into the overall cost of a material or a construction method. Today stick framing is the most common means for small construction. It is straightforward, understood, and the materials and skillset for this kind of construction are universally available. However, it is site dependent, time intensive, and generates a great deal of onsite waste. Construction with SIPs (structural insulated panels) is emerging as an alternative to stick framing with quicker construction time, greater performative properties, and less construction waste. CLT (cross laminated timber) is an emerging material and construction method which combines structure, insulation, fire protection, shear, and finish into one massive panel. While knowhow and availability of CLT is not yet readily available here the abundance of forestry products, green mentality, and progressive mindset show great potential for its future application in such projects.

With both construction and materiality a key component to ease of construction, appearance, and reduction of waste is size. The longest readily available structural member for both timber framing and SIPs is 16' in length. This size dictates the width of the structure so that various methods and materials can be used with minimal to no cutting. The same logic is applied to the exterior cladding where materials come in standard 12' lengths. Rather than cutting to size or butting and caulking cladding elements to appear as one continuous piece joints are celebrated and accentuated with flashing. This allows factory sealed ends to be maintained and creates a unique composition to the façade materials. Great care has been taken to compose the interiors in a similar way by combining all wet features to share a common wall which means that pipes can be doubled up and greatly reduced in length. All areas for casework have been designed in two foot modules so that standard units can be used and combined in ways to fit an individual's needs and desires.

*"In Mies's 'less is more' postulate there is also a claim to happiness through asceticism. More concentration and depth should be achieved by using less elements of form and a simpler design. The "search for clarity" finds an answer in the reduction to skin and bones and the straight lines of their arrangement. **Here, less means a necessary minimum, but also an achievable optimum.**"*

Christian Schittich,
In Detail Building Simply



Materiality

When looking at the economics of a project how a structure is clad and finished is just as important as show it is built. Using off the shelf materials that are both familiar and durable keeps with the economic consciousness of these small dwellings. Hardie Board, Hardie Plank, metal roofing, and three tab composite shingles are all readily available, long lasting, and easy to apply. The familiarity of these materials also reflects the context of utilitarian alleyway structures and single-family homes that they are built amongst.







Approach from south (top)
View from outdoor green space (bottom)





View from main house backyard (top)
Entrance (bottom)





View of living space (top)
View of living space and kitchen (bottom)





View up to loft (top)
View down from loft (bottom)

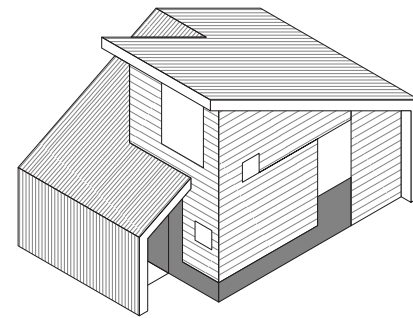
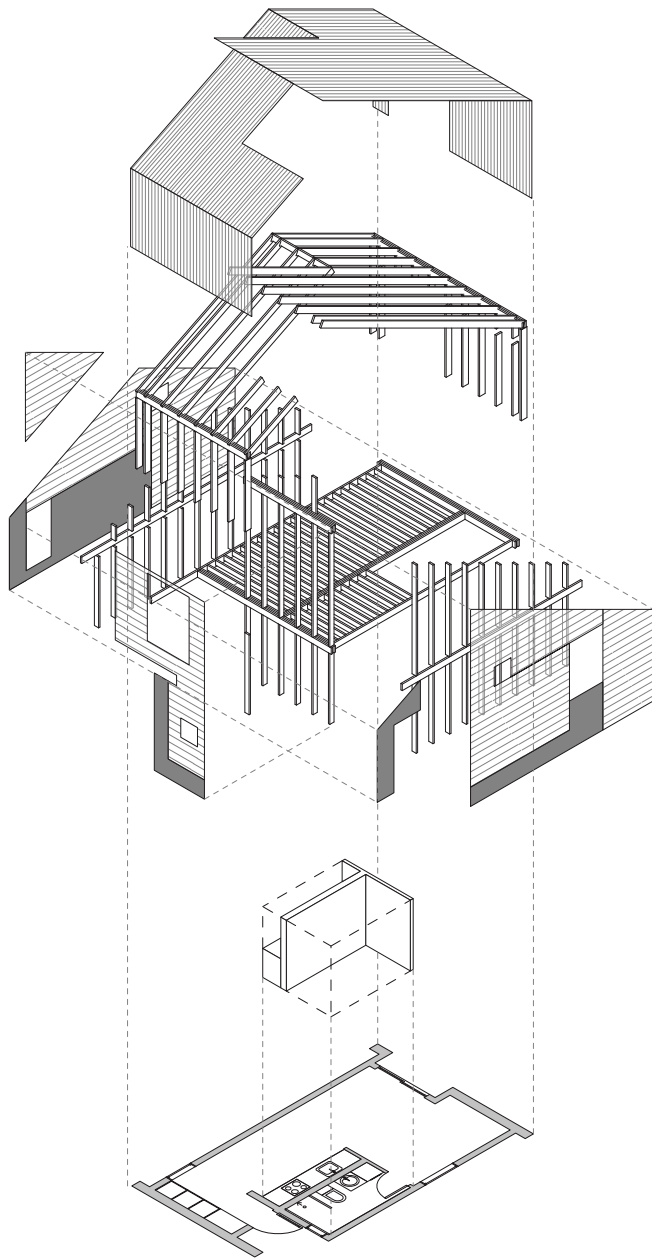



View from the north



IX. CONCLUSION

This thesis is not proposing a final solution applicable to all conditions, needs, and desires for detached accessory dwelling units built on residential alleyways, but instead explores what might be possible when applying an ethic of development for DADUs in Seattle. This scale had to be explored in order to apply ideas on a micro level and test their validity against the larger backdrop of alternative forms of infill such as five-over-ones, aPodments, townhomes, and other forms of multi-family attached dwellings. The project presented here is by no means a silver bullet for densification, but it engages with the overall history of growth of our city, and it exposes an area of planning that should be explored to its fullest potential.

The city must recognize the need for a framework that deals with the implementation of alleyway DADUs from an economic, environmental, and most importantly, social level. To accomplish this, the ideas, themes, and questions posed by this thesis will be presented to the Seattle DPD. Too often, designs are a reaction to the dictates of code rather than a response to the larger ideas of how our city should be shaped and realized.

One way to implement and test the economic, social, and environmental potentials of DADUs built on residential alleyways is through an interdisciplinary design build studio facilitated by the College of Built Environments. The CBE could use the ideas put forth by this thesis as a framework to allow aspiring planners, architects, and landscape architects to experience firsthand the inner workings of policy, construction, and environment, and how each can be used to benefit the other. Such a project could help students, homeowners, and citizens realize the potential they have as individuals to help shape the growth of our city in a positive way.

As architects, it is up to us to engage the planners, policy makers, and the public, to reveal the opportunities and potential that can make our city better to improve the quality of life here. Simply put, DADUs can offer what other small and dense dwelling units cannot: semi-private and semi-public spaces such as gardens, front porches, and public right-of-ways. These are all places where social interactions and connections to nature can occur.

"Society has a critical mass. ...move them and their daily activities closer together, and the benefits cascade: their neighborhoods grow safer, they become more attuned to one another's needs, and their lives, generally, become more varied and engaging."

Jane Jacobs,
The Death and Life of Great American Cities

X. BIBLIOGRAPHY

Books:

- Alison, Filippo. *Le Corbusier: Interior of the Cabanon*. Milan: Triennale Electa, 2006. Print.
- de Botton, Alain. *The Architecture of Happiness*. New York: Pantheon Books, 2006. Print.
- *del Valle, Christina. *Compact Houses*. New York: Universe, 2005. Print.
- Droker, Howard. *Seattle's Unsinkable Houseboats*. Seattle: Watermark Press, 1977. Print.
- Farr, Douglas. *Sustainable Urbanism: Urban Design with Nature*. Hoboken: John Wiley & Sons, 2008. Print.
- Garvin, Alexander. *The American City: What Works, What Doesn't*. New York: McGraw-Hill, 1996. Print.
- *Gehl, Jan. *Life Between Buildings*. New York: Van Nostrand Reinhold, 1980. Print.
- *Glassie, Henry. *Vernacular Architecture*. Philadelphia: Material Culture, 200. Print.
- Gottfried, Herbert and Jan Jennings. *American Vernacular: Buildings and Interiors 1870-1960*. New York: W. W. Norton & Company, 2009. Print.
- Harris, Steven and Deborah Berke. *Architecture of the Everyday*. New York: Princeton Architectural Press, 1997. Print.
- *Hildner, Claudia. *Small Houses: Contemporary Japanese Dwellings*. Basel, Birkhäuser, 2011. Print.
- Holl, Steven and Juhani Pallasmaa and Albero Pérez-Gómez. *Questions of Perception: Phenomenology of Architecture*. Tokyo: a+u Publishing, 2006. Print.
- Jacobs, Jane. *The Death and Life of Great American Cities*. New York: Vintage Books, 1961. Print.
- Jeanneret, Charles Edouard. *The Modulor*. Cambridge: Harvard University Press, 1954. Print.
- Jetsonen, Jari and Sirkkaliisa Jetsonen. *Alvar Aalto Houses*. New York: Princeton Architectural Press, 2011. Print.
- *Klanten, Robert. *Data Flow: Visualising Information in Graphic Design*. Berlin: Gestalten, 2008. Print.
- Le Corbusier. *Towards A New Architecture*. New York: Dover Publications, 1986. Print.
- *McKean, John. *Learning From Segal*. Berlin: Birkhäuser, 1989. Print.
- Meek, Christopher M. *Daylighting Design in the Pacific Northwest*. Seattle: University of Washington Press, 2012. Print.
- *Miller, David E. *Toward a New Regionalism: Environmental Architecture in the Pacific Northwest*. Seattle: University of Washington Press, 2005. Print.
- Mostafavi, Mohsen and David Leatherbarrow. *On Weathering: Life of Buildings in Time*. Cambridge: The MIT Press, 1993. Print.
- Norberg-Schulz, Christian. *Existence, Space & Architecture*. New York: Praeger Publishers, 1971. Print.
- Norberg-Schulz, Christian. *Genius Loci: Towards a Phenomenology of Architecture*. New York: Rizzoli, 1984. Print.
- Norberg-Schulz. *Nightlands: Nordic Building*. Cambridge: The MIT Press, 1996. Print.
- Nuijsink, Cathelijne. *How To Make A Japanese House*. Rotterdam: NAI Publishers, 2012. Print.
- Nyberg, Folke and Victor Steinbrueck. *An Urban Resource Inventory for Seattle*. Seattle: Historic Seattle Preservation and Development Authority, 1975. Print.
- Ochsner, Jeffrey Karl. *Shaping Seattle Architecture: A Historical Guide to the Architects*. Seattle: University of Washington Press, 1998. Print.
- Owen, David. *Green Metropolis*. New York: Penguin, 2009. Print.
- *Pople, Nicolas. *Small Houses*. London: Laurence King, 2003. Print.
- Richardson, Phyllis. *Nano Houses*. London: Thames & Hudson, 2011. Print.
- *Rocheleau, Paul and June Sprigg. *Shaker Built*. New York: The Monacelli Press, 1994. Print.
- Rosenfeld, Erika. *Building with Light in the Pacific Northwest: The Houses of Thomas L. Bosworth, Architect*. San Rafael: ORO editions, 2007. Print.

Schildt, Göran. Alvar Aalto: In His Own Words. New York: Rizzoli, 1998. Print.

*Schittich, Christian. In Detail Building Simply. Berlin: Birkhäuser, 2005. Print.

Seamon, David and Robert Mugerauer. Dwelling, Place and Environment: Towards a Phenomenology of Person and World. Boston: Martinus Nijhoff Publishers, 1985. Print.

*Slavid, Ruth. Micro: Very small buildings. London: Laurence King Publishing, 2007. Print.

Steinbrueck, Victor. Seattle Cityscape. Seattle: University of Washington Press, 1962. Print.

Steinbrueck, Victor. Seattle Cityscape #2. Seattle: University of Washington Press, 1973. Print.

Talen, Emily. City Rules: How Regulations Affect Urban Form. Washington: Island Press, 2012. Print.

Treib, Marc. Spatial Recall: Memory in Architecture and Landscape. New York: Routledge, 2009. Print.

Upton, Dell and John Michael Vlach. Common Places: Readings in American Vernacular Architecture. Athens: University of Georgia Press, 1986. Print.

*Walker, Lester. Tiny Houses. Woodstock: The Overlook Press, 1987. Print.

Whyte, William H. The Social Life of Small Urban Spaces. New York: Project for Public Spaces, 1980. Print.

*Zeiger, Mimi. Micro Green: Tiny Homes in Nature. New York: Rizzoli, 2011. Print.

Zeiger, Mimi. Tiny Houses. New York: Rizzoli, 2009. Print.

Journals:

Holl, Steven. "Questions of Perception—Phenomenology of Architecture" Architecture and Urbanism Special Issue July (1994): 39-156. Print.

Martin, Michael David. "The case for residential back-alleys: A North American perspective" Journal of Housing and the Built Environment Vol. 17, No. 2 (2002): 145-171. Print.

Pallasmaa, Juhani. "An Architecture of the Seven Senses." Architecture and Urbanism Special Issue July (1994): 27-37. Print.

Articles:

Elefante, Carl "The Greenest Building Is...One That is Already Built," Forum Journal Summer 2007

Young, Bob. "Backyard apartments? Seattle may experiment with the idea." Seattle Times Tuesday, June 27th 2006

Web:

www.census.gov

www.seattle.gov

www.vancouver.ca