

© Copyright 2019

Shakiba Ahmadi

An Analysis of Urban Form and Canyon for Performative Daylighting Design

Shakiba Ahmadi

A thesis

submitted in partial fulfillment of the
requirements for the degree of

Master of Science in Architecture

University of Washington

2019

Committee:

Mehlika Inanici
Christopher Meek

Program Authorized to Offer Degree:

School of Architecture

University of Washington

Abstract

An Analysis of Urban Form and Canyon for Performative Daylighting Design

Shakiba Ahmadi

Chair of the Supervisory Committee:
Associate Professor Mehlika Inanici

Urbanization and densification are generally posed as a dichotomy between economic vitality and access to sunlight, daylight, and views. Daylight provides the highest quality of light. Building façade design should allow adequate levels of daylight penetration, and reduce the need for artificial lighting. Previous research and technology had focused on window sizes, window location, glazing types, and design of external and internal shading devices. However, the critical effects of surrounding block building mass, façade material reflectivity, and their interrelationship are overlooked in most daylighting design and research.

Although recent studies on urban planning concentrate on daylight availability, and utilize climate based annual daylighting simulations in a given urban zone or block, the general tendency is to oversimplify the simulation models to facilitate rapid simulation processes. Computational

efficiency is necessary, but the credibility of the simulation results depend on the accuracy of the input data. This thesis addresses to a need for a refined workflow for urban level daylighting simulations. The refined workflow provides flexibility in changing the design criteria, material reflectivity, and automated shadings operations.

This proposed daylighting analysis workflow addresses to a gap between urban-level and building-level designs. It is used to explore solutions, where densification and performative daylighting design are mutually beneficial. The resulting data are used to critically discuss the limitations of current urban zoning rules. Alternative developing patterns and façade designs are demonstrated to support better daylit urban layouts and buildings.

Acknowledgements

I would like to express the deepest appreciation to my committee chair, Prof. Mehlika Inanici, who has exceptional knowledge regarding computational lighting design. I also wanted to take the opportunity to thank her for introducing me to a field I knew little about it and for guiding me to find the right resources and to think clearly and methodically. I feel so fortunate to meet Mehlika and have her as a wonderful mentor in my academic life. Without her guidance and persistent help, this thesis would not have been possible.

I would also like to thank my committee member Prof. Chris Meek for helping me and giving valuable advice throughout my studies.

It is a great pleasure to express my gratitude to Prof. Brian Johnson for giving me the opportunity to be a part of DMG and for introducing me to computational design thinking and challenging my design preconceptions.

I would also like to thank my friends for supporting me through my journey at UW.

I would finally like to dedicate this work to my mom and my sister for their unconditional support and love.

TABLE OF CONTENTS

Table of Contents	vi
LIST of TABLES	xi
Chapter 1. Introduction	12
Chapter 2. Literature Review on urban daylight Design	14
2.1 Utilization of Solar Geometry on Urban scale Daylight Studies	14
2.1.1 The right to the sun in urban design.....	15
2.1.2 Solar access practices at a building level.....	20
2.1.3 Solar access practices at the street-level	29
2.1.4 Remarks	31
2.2 Solar radiation	32
2.2.1 Insolation Factor	32
2.3 Climate-Based Daylight Availability	34
2.4 What are the metrics for urban daylight simulation from the past to present?	38
2.4.1 Geometry-based investigations: Sky view factor (SVF)	38
2.4.2 Radiation-Based Investigations: Incident Solar Radiation	40
2.4.3 Illuminance based Investigations	41
Chapter 3. METHODOLOGY	45
3.1 Setting.....	45
3.2 Workflow	47
3.1 Simulation Setup:	51

3.1.1	Geometric Exploration.....	52
3.1.2	Material Exploration.....	56
3.1.3	Window-to-wall Ratio Exploration.....	58
3.1.4	Shadings Exploration.....	59
3.1.5	Tower's Location Exploration.....	62
Chapter 4. results		64
4.1	Simulations for the uniform height configuration.....	64
4.2	Simulations for the quasi-random height configuration.....	66
4.3	Compare all the uniform height results with quasi random heigh	69
4.4	Simulation for the informed design.....	72
4.4.1	Automated Shading Strategies.....	75
4.4.2	Window-to-Wall Ratio (WWR).....	77
4.4.3	Material Reflectivity.....	78
4.4.4	Circulation Area.....	79
4.5	Remarks:.....	81
Chapter 5. conclusions		82
References.....		84

Figure 1 - A reticular plant of Olinto, Greece [6]	15
Figure 2 - (left) El-Lahun in Egypt [6]	16
Figure 3 - Ancient solar city of Priene [6]	16
Figure 4 - Classical Greek home in Priene [6].....	16
Figure 5 - Atkinson was inspired by building laws of Paris of 1902 [6]	18
Figure 6 - London Building Act of 1984 prescribing sloping roofs instead of curved ones of 1901 [6].....	18
Figure 7 - (left) - Solar envelopes and housing [9].....	19
Figure 8 - (Right)- Rates compared between keeping solar rights planning (down) and regular planning (up) [11]	19
Figure 9 - Barcelona, plan of 1891 designed by Ildefons Cerdà i Sunyer	21
Figure 10 - (Left) - Barcelona, a city block with the truncated corners.....	22
Figure 11 (Right) - Barcelona, the city blocks had to be built on only two of the four sides, or parallel to each other or contiguous	22
Figure 12 - Barcelona, aerial view of urban grid [6].	22
Figure 13 - Barcelona, a city block model in rhinoceros	23
Figure 14 - Barcelona, current city block Model in Rhinoceros with further development over the years (They constructed all four sides)	24
Figure 15 - Building Height rule: the rule of 45° [6].....	24
Figure 16 - Boulder, Building Height rule in the three Solar Access Area	25
Figure 17 - The mirrors are mounted to keep track of the sun [14].....	27
Figure 18 - People cheer during an inauguration of the sun mirrors [14].....	27
Figure 19 - Looking down on Rjukan, the path of the reflected sunlight [14].	27
Figure 20 - Mass plan of Ksar El Mihane in Djanet as a typical compact cellular layout	28
Figure 21 - Typical streets found in southern Algerian Ksur [15].....	29
Figure 22 - Wide range of environmental factors were studied at the Lower Yonge District [19]	30
Figure 23 - Solar access modelling that in the lower Yonge District [19]	30
Figure 24 - Solar Carve Tower, Studio Gang [20].....	31
Figure 25 - Sky-factor assessment for building	33
Figure 26 - Annual illuminance in street canyon with surface reflectance variables [5] .	35

Figure 27 - The solar envelope design provide building (right model) that does not shade its neighbors in 11-13 pm December 21 in this model. (Location: Seattle)	38
Figure 28 - Measuring Sky View Factor.....	39
Figure 29 - Dynamic overshadow simulations [27].....	40
Figure 30 - CIE sky conditions [28]	41
Figure 31 - A comparison of common supply-focused daylight performance metrics (DPMs). Climate: Berlin. Occupancy: 8AM-6PM [38]	44
Figure 32 - Top 40 U.S. Markets for Office Deliveries in 2019 [41].....	46
Figure 33- The summary of the proposed workflow	47
Figure 34 - Comparison of daylight availability in two massing designs. In the new massing proposal, better daylighting scheme is achieved at all floors of the building	48
Figure 35 - Block typology diagram.....	49
Figure 36 - Zone mapping in downtown Seattle [Perkins+will]	49
Figure 37 - Typical Seattle block module (Left), Virtual site (Right)	50
Figure 38- The footprint of the generic geometries at ground level -Typologies inspired from a previous study [46] for lot coverage	52
Figure 39 - Block typology evolution matrix	53
Figure 40 - 3D Model with different layers	54
Figure 41 - Five cases with uniform height distributions	54
Figure 42 - Five cases with random distributions.....	55
Figure 43 - Simplified model with assigned materials	57
Figure 44 - Section of an urban canyon with different reflectivity levels	58
Figure 45 – The spandrel glass is covering floor structure, ceiling plenums [47].....	58
Figure 46 - Roller Shade [48]	59
Figure 47 - Diva: roller shade & custom shade system	59
Figure 48 - Manual control sensors	60
Figure 49 - Automated control sensors.....	61
Figure 50 - Automated control sensor angle -90° to +90° (Horizontal and Vertical)	61
Figure 51 - If the UDI-overlit is higher than 15 % of the year during daylight hours, then the automated window shading system is deployed	62

Figure 52 - Defining eight points around the site to obtain the SVF percentage.....	63
Figure 53 - SVF percentages in the proposed locations of towers	63
Figure 54 - Uniform height typologies with individual floors UDI (300-3000) map.....	65
Figure 55 – UDI ₍₃₀₀₋₃₀₀₀₎ map of Quasi-Random (1) height typologies with individual floors	66
Figure 56 - UDI ₍₃₀₀₋₃₀₀₀₎ map for Quasi-Random (2) height typologies with individual floors	68
Figure 57 - Quasi-Random (2) height typologies with individual floors UDI underlit & overlit map	71
Figure 58 – Determining the towers’ location based on SVF percentage around the block	73
Figure 59 - Sky obstruction percentage in different heights on the boundary of the studied block	74
Figure 60 -Step 1- Simulation result for the informed design phase (studied parameter is automated shadings).....	75
Figure 61 - Step 2- Simulation result for the informed design phase (changing parameter is shaded automation angle).....	76
Figure 62 - Step 3- Simulation result for the informed design phase (changing parameter is window-to-wall ratio)	77
Figure 63 - Figure 58 - Step 4 - Simulation result for the informed design phase (changing parameter is material reflection)	78
Figure 64 - The middle parts of the floor plates tend to have less exposure to daylight ..	79
Figure 65 - Step 5 - Simulation result for the informed design phase (changing parameter is removing circulation area)	80
Figure 66 - Final comparison between the original geometry and the last studied case (the informed one)	81

LIST OF TABLES

- Table 1 - Summary of cases being studied**Error! Bookmark not defined.**
- Table 2 – Summary of cases being studied (The second quasi-randomized configuration provides more variation in massing distribution)**Error! Bookmark not defined.**
- Table 3- Uniform height typologies - UDI results.....**Error! Bookmark not defined.**
- Table 4 - Quasi-Random (1) height typologies - UDI results**Error! Bookmark not defined.**
- Table 5 - UDI (300 – 3000) percentage for Quasi-Random (1) height typologies.... **Error! Bookmark not defined.**
- Table 6 - Quasi-Random (2) height typologies - UDI results**Error! Bookmark not defined.**
- Table 7 - The average UDI values for all the uniform height cases and random height cases**Error! Bookmark not defined.**
- Table 8 - Sky obstruction percentage in different heights on the boundary of the studied block**Error! Bookmark not defined.**
- Table 9 – Comparing UDI result for the first 10 lower floors**Error! Bookmark not defined.**

Chapter 1. INTRODUCTION

Historically, the urbanization and densification is generally posed as a dichotomy and tension between economic vitality and access to sun(light), views, and fresh air, where the rights of individuals and public, or fair access among different property owners compete and conflict with each other. Urban zones are developed to address the issue, yet they are routinely challenged due to the pressures of rapid growth; and costly lawsuits are becoming more and more common. Studies on the impact of urban form and canyon has a long history. Existing daylighting studies on urban form and canyon are categorized as three groups:

a) The traditional urban planning approaches focus on maximum access to direct sunlight . These approaches are based on solar geometry on a given latitude, and they do not consider local climatic conditions. They do not provide information on the useful daylight illuminances (UDIs) in interiors;

b) There are studies that focus on the annual incident solar radiation (insolation) levels on façade surfaces. Insolation computations include the impact of local climate and the materiality. They are most useful to design passive solar strategies or gauge (photovoltaic) energy production. Their usability for daylighting is limited, as the depth of the building or the functionality of the space is not considered.

c) More recent studies utilize climate-based annual daylighting simulations. This approach provides significant progress compared to the previous two methods. Although climate-based approaches are successfully applied at building scales, its derivatives for urban scale simulations are relatively oversimplified. It is prevalent to assume a constant reflectivity for outdoor surfaces. In reality, urban scenes display a spectrum of diverse materials. Fully glazed facades and opaque

materials with varying reflectivity properties can have significant impact on the reflected light. Daylight availability may depend on the reflected light, rather than the sun and the sky, especially in the lower floors of buildings in dense urban neighborhoods. Another shortcoming is that analysis criteria in existing approaches are usually limited to achieving an indoor target (minimum) illuminance value, and it is assumed that glare is prevented with automated shading devices that filter out all sunlight to prevent glare. Such a tight control may not be feasible, or even desirable.

The objective of this thesis is to utilize a daylight simulation methodology and workflow that explores relevant parameters for neighborhoods that goes beyond today's simplified rules. The refined workflow can bridge the gap between the urban and individual building designs. The goal is to propose solutions, where densification and performative daylighting design are mutually beneficial. Alternative massing and façade designs are explored to support better daylit urban layouts and buildings.

The thesis is organized in five chapters. Literature review on solar geometry, solar radiation, urban daylight simulation, and existing daylighting metrics is discussed in Chapter 2. Chapter 3 presents a refined simulation and evaluation workflow that supports economic viability, growth and densification at the urban scale, along with performative daylighting designs at the individual building scale. Simulation results from Radiance/DIVA simulation software [1] [2] are presented in Chapter 4. In chapter 5, conclusions, findings and future contributions are discussed.

Chapter 2. LITERATURE REVIEW ON URBAN DAYLIGHT DESIGN

A high percentage of the world's population are living in cities and urban areas. Migration from rural to urban areas has greatly increased urban densities, and poses significant challenges [3]. In high-density areas, there is a contradiction between space-use efficiency and daylight availability [4]. Therefore, studying the impact of urban densities on building energy use and occupant well-being is important. The factors that impact successful daylight design include climatic conditions, building design, materials, and functionality [5]. Within this context, urban zoning rules must consider the relationship between an individual building and its context. As discussed in the introduction, previous studies on urban level daylighting are discussed here under three categories: a) solar geometry, b) solar radiation, and c) climate-based daylight availability. This chapter is organized to provide background information on the utilization, applications, strengths, and weaknesses of these three categories.

2.1 UTILIZATION OF SOLAR GEOMETRY ON URBAN SCALE DAYLIGHT STUDIES

The traditional urban planning based on “solar geometry” mainly focus on sunlight access on the façade; luminance distributions of the sky dome, and glare from direct sunlight are not considered.

As a result, they do not provide information about the useful daylight levels in interiors.

The solar geometry based investigations are divided into three groups:

- The right to the sun in urban design
- Solar access practices at a building level
- Solar access practices at a street level

2.1.1 *The right to the sun in urban design*

Sun has a fundamental role in sustaining life. The concept of access to the sunlight was considered in the formation of historical cities. A study of classical Greek towns reveal that the solar rights concept was applied throughout their formation processes. The houses were constructed in a way to provide equal access to the winter sun for all citizens. The buildings were oriented toward the southern horizon [6] .

The settlement of Olinto, Greece was constructed based on a grid plan with north-south/east-west axes (Figure 1). To have access to the sun, all houses had a south facing façade, and a façade toward an inner courtyard. Priene (Macedonia) and El-lahun (Egypt) are among other examples of sun cities with their checkerboard layout scheme (Figures 2-3) [6].

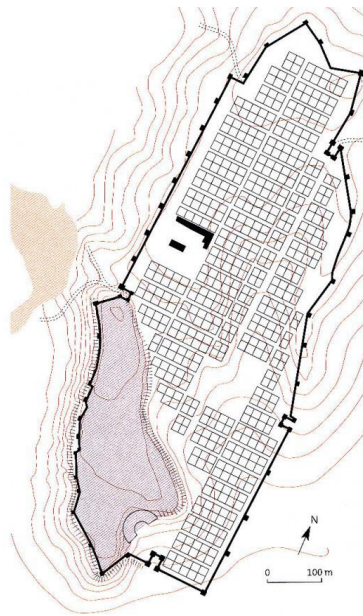

Figure 1 - A reticular plant of Olinto, Greece [6]



Figure 2 - (left) El-Lahun in Egypt [6]

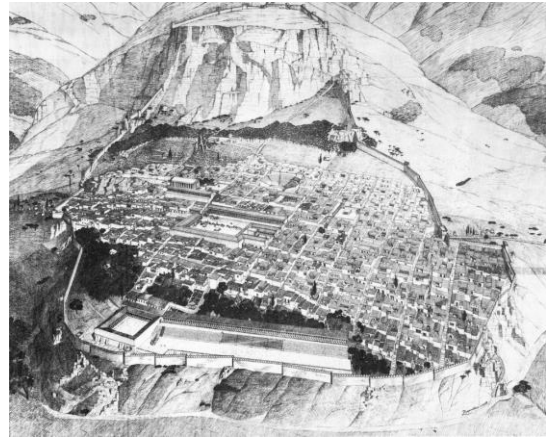

Figure 3 - Ancient solar city of Priene [6]

Ancient Greeks understood that summer sun is higher in the sky, and winter sun tracks a lower path. They made their buildings with a portico toward south, which can get sunlight during winter. In this way, the main rooms of the houses receive sufficient solar rays coming through the porch. At the same time, they were protected from the cold winds of the north. In summer, roof shadings were sufficient to keep out the solar rays. These principles are good indicators of solar architecture techniques in ancient Greece (Figure 4).

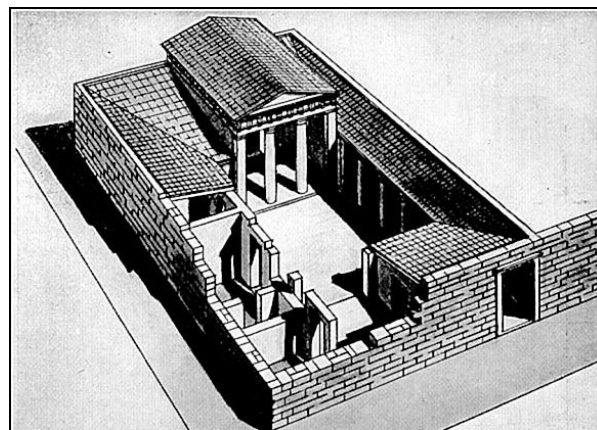

Figure 4 - Classical Greek home in Priene [6]

During the population growth and urbanization in the 19th century, the concept of solar access in the cities had become noticeable. The main reason for this movement was the industrial revolution

that lead to increased spread of diseases. Many people died in over-populated buildings in narrow streets, which were severely under-illuminated. For securing the sun access and fresh air, a series of regulations and laws were set up in European and US cities between 1850 and 1930. These principles were concerned about the height and width of the streets. William Atkinson was an architect that suggested many changes in these rules. He argued that building shape and form is as much important as the characteristics of the streets. He was among the first architects, who introduced the ideas of sunspaces. In 1912, he published a book titled “The orientation of the buildings, or planning for sunlight”. In 1969, Tony Garnier published a book titled “rule of 45 degrees”. The book placed the southern facade of the building at a distance equal to the nearest building height on the south side. It was mentioned in Cite Industrielle¹ [7], but due to the poor adaptability of the technique to different heights, it was not widely adopted.” [8]

The rules affected urban development in major cities. The façade of a building in Paris could not have a building height greater than 20 meters [6]. The attic above the building is curved, and has a height limitation of 10 meters. As a result, solar access was provided to the lower parts of streets with maximized building density. There were similar urban laws in London; sloped roofs and terracing were preferred instead of the curved roofs (Figure 6) [6]

¹ Cité Industrielle, urban plan designed by Tony Garnier and published in 1917 under the title of Une Cité Industrielle. It represents the culmination of several philosophies of urbanism that were the outgrowth of the Industrial Revolution in 19th-century Europe

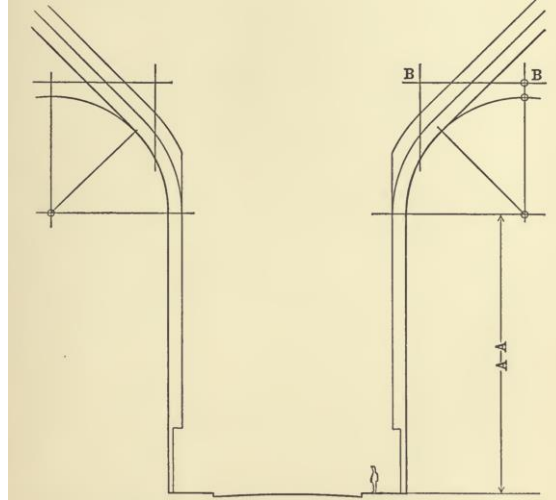

Figure 5 - Atkinson was inspired by building laws of Paris of 1902 [6]

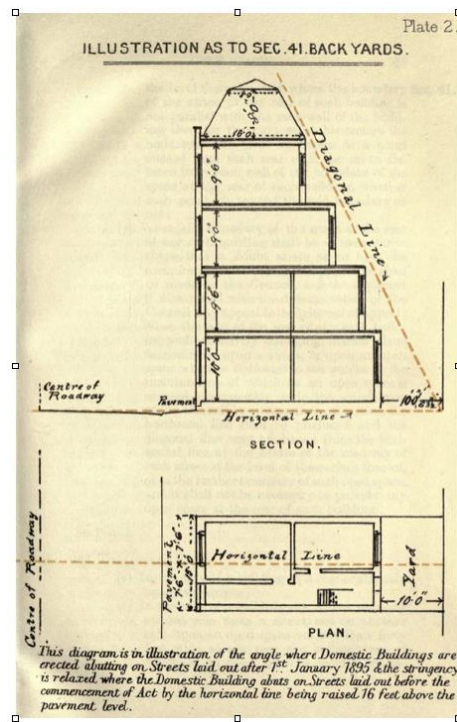

Figure 6 - London Building Act of 1894 prescribing sloping roofs instead of curved ones of 1901 [6]

2.1.1.1 Solar Envelope

Two decades after the publication of Atkinson's book, solar architecture became an active topic in United States. Concepts such as solar envelopes [9] were developed to effectively shape building masses for improved solar access at the building level.

Ralph Knowles is an architect who introduced the concept of solar envelope technique [10]. "Solar envelope is a maximum volume whose shape is determined by the relative motion of the sun." [11]. If a neighborhood is designed with this technique, the buildings does not shade surrounding buildings. This solar envelope is like making a "shell" which can be determined i) by physical boundaries of neighboring properties such as geometrical constraints emerging from the shape of the lots and roads, and ii) by the desired period of solar access [6]. Knowles applied this concept in two steps: by sloping the roof or upper floors, and then, by intersecting the sloping lines with the sun's rays. This technique yielded to a specific category of architecture, where the geometrical characteristics depend on the boundary conditions and the latitude of the site.

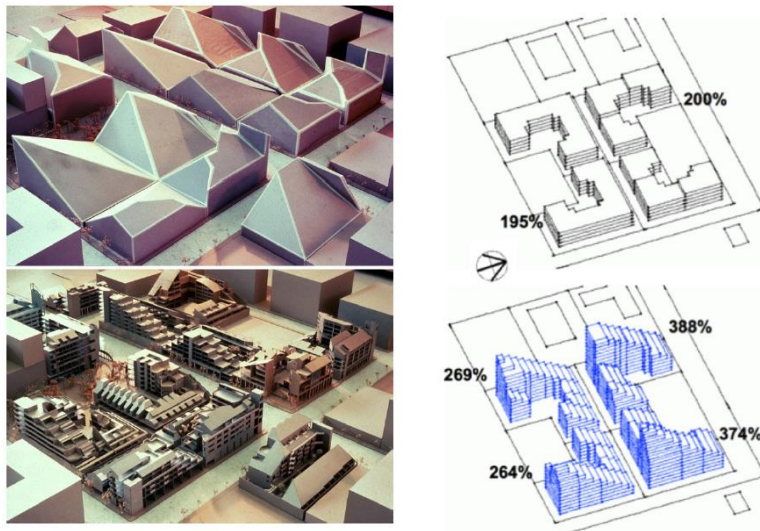

Figure 7 - (left) - Solar envelopes and housing [9]

Figure 8 - (Right)- Rates compared between keeping solar rights planning (down) and regular planning (up) [11]

The solar envelope concept improves the solar availability in buildings, and it avoids the overshadowing phenomenon. It can improve human health, well-being, and passive solar heating in the buildings. However, it does not address the glare problem, nor it is dependent on weather patterns [6].

2.1.2 *Solar access practices at a building level*

Even today, most of planning authorities do not have solar analysis requirements, or the analyses are limited to basic shadow studies. The shadow studies are based on geometric relationship between the sun, the building façade and surrounding occluding surfaces. Weather is not taken into account. Reflected light is not considered. Most of the shadow diagrams are two-dimensional and demonstrate the overshadowing patterns at the street level. This approach may be useful only for addressing the conflict between the rights of an individual property owner and public, as research clearly show that public space benefits from access to sunlight [12].

In public spaces the main goal is solar access, not glare prevention. In outdoors, people are adapted to high levels of light. They are not as susceptible to glare in the same manner as indoors. Solar access is the main determinant in current urban zoning guidelines that include rules on the width of streets, setback distances and height of buildings derived from solar angles. Further recommendations include street and grid orientations.

Mapping street shadows in critical times of the year (typically illustrated in solstices and equinoxes) can be supplemented with daily hours of access to direct sunlight (both at the street or building levels). The following section discusses the solar access laws around different parts of the world. Discussions focus on building level design rules and regulations:

2.1.2.1 Barcelona example

One of the most impressive examples of a solar city design in the 19th century is the planning of a district in Barcelona, by Ildefons Cerdà Sunyer. It can be considered as the largest solar district, which is located in the central part of the city (an area of 7.45 km²). This part is the most populated part of the city and entire Spain. Cerda designed this urban plan like a “chessboard” [6].

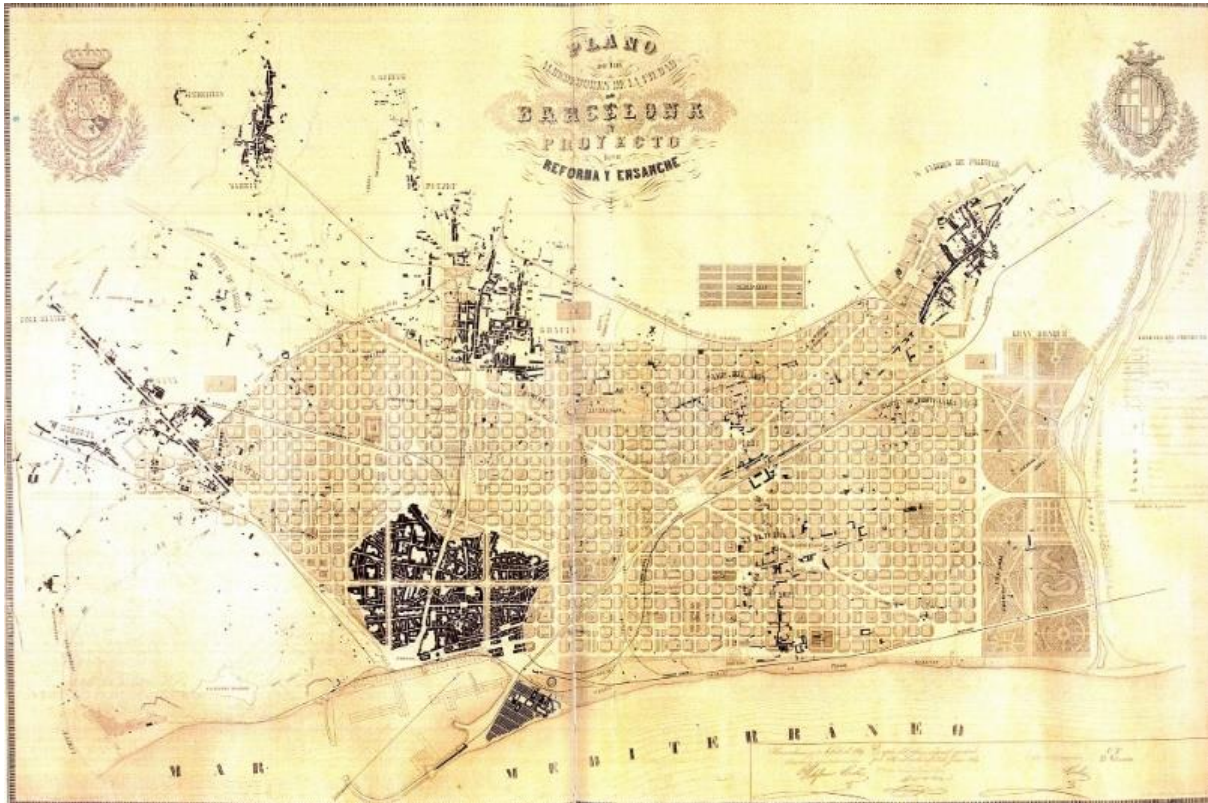

Figure 9 - Barcelona, plan of 1891 designed by Ildefons Cerdà i Sunyer

This neighborhood has larger urban blocks, 113 by 113 meters with 20-meter street cut crossed by a few 50-meter boulevards. In the original design, the buildings in this urban district had a maximum of 16-meter height, and the roads did not exceed 20 meters in width. Only two sides of the blocks were permitted to be built, and therefore, the buildings do not block each other [6].

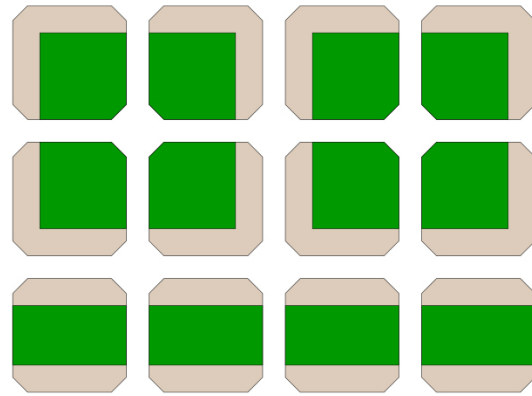
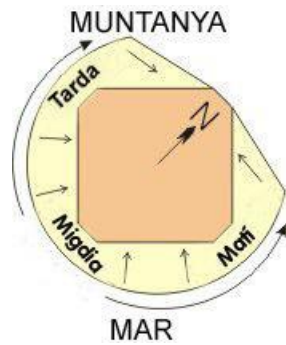

Figure 10 - (Left) - Barcelona, a city block with the truncated corners

Figure 11 (Right) - Barcelona, the city blocks had to be built on only two of the four sides, or parallel to each other or contiguous

This method received many criticisms in that era. One of these criticisms was the significant decrease in the buildable area, which causes economic loss. In years, all the four sides of each octagonal block were constructed, and the courtyard sizes were reduced to 20 by 20 meters. The features of original design that have remained unaffected are the truncated corners and the orientation of the roads [6].



Figure 12 - Barcelona, aerial view of urban grid [6].

For better demonstration of the applied techniques for this urban area in Barcelona, daylight simulation are illustrated below. Solar analysis shows that even on December 21st at noon, when the sun is in its lowest position, there is minimal overshadowing in this neighborhood (Figure 12).

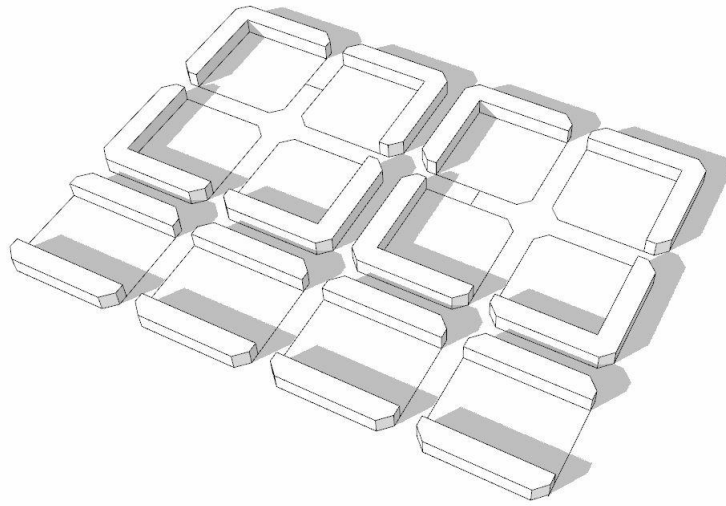

Figure 13 - Barcelona, a city block model in rhinoceros

Although over the years, they constructed all four sides. The solar analysis illustrates that the buildings in this urban area still have better overshadowing limitations than typical street layouts, due to the initial wisdom in urban planning.

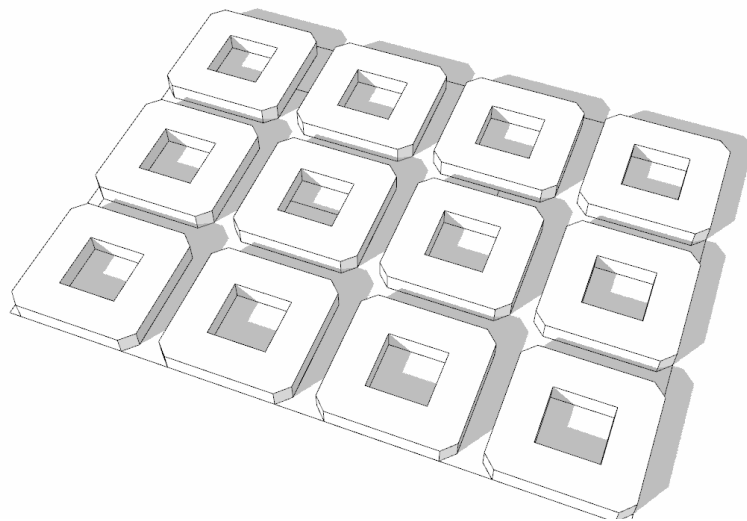

Figure 14 - Barcelona, current city block Model in Rhinoceros with further development over the years (They constructed all four sides)

There is a possibility to add additional floors, but the original planning specifies a setback in order to prevent shadow casting on the neighboring buildings.

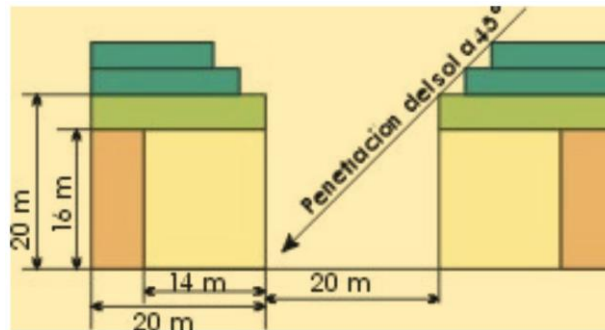

Figure 15 - Building Height rule: the rule of 45° [6].

This example illustrates that early decisions on urban master planning in terms of providing sun access for a neighborhood can secure the desirable solar access performance, even after new developments.

In the following section, four groups of general zoning principles are presented. Their main goal is to limit the overshadowing of new developments on surrounding properties. These zoning rules are applied to all properties within a given zone, regardless of whether adjacent properties have a solar system or not. Below are examples of zoning policies in three cities.

2.1.2.2 Boulder, Colorado

Boulder has used “solar fence” rule as a creative protection for most of its new development zones. A solar fence creates a hypothetical border along the property line. The property must not be shaded between 10 a.m. and 2 p.m on the winter solstice with the new developments. In Boulder, zoning districts have been categorized into three solar access areas. Solar access area I have properties protected by a 12 foot solar fence. In solar access area II, this number is 25 foot. The third category are the properties that are not protected by a solar fence, they are protected through solar access permits² [13].



Figure 16 - Boulder, Building Height rule in the three Solar Access Area

Boulder has also proposed specific requirements for new structures. All roofs must provide a surface orientation within 30° of true east-west direction, be flat or south sloping. It has to be able to structurally support at least 75 square-feet of unshaded solar collectors [13].

² Solar Access Permits

Numerous states and local governments have adopted policies that grant specific solar access protections to property owners who have installed a solar system. Most jurisdictions that provide these protections grant solar system owners the rights to the airspace over their neighbor's property through a solar access permit.

2.1.2.3 Ashland, Oregon

City of Ashland's approach to solar accessibility is similar to Boulder's solar fence protections. The only difference is that Ashland code creates minimum setback limitations based on the height of the new development and the slope of the lot rather than determining the actual height of a potential shadow at the property line. It secures a satisfying level of solar exposure for the surrounding property [13].

2.1.2.4 Santa Cruz, California

Santa Cruz takes a different approach for solar access laws. The local code mandates new structures to be oriented and constructed in a way to preserve solar access for neighboring properties. The code does not determine the manner or extent to which solar access should be protected.

2.1.2.5 Rjukan, Norway

An interesting example in the solar access is a Norwegian town called Rjukan, which remains in shadow for half of the year. Rjukan, is located in the bottom of a valley between steep mountains. It is cut off from direct sunlight for five to six months a year due to the obstruction of the surrounding mountains. This case focuses on a solution to solve dark and gloomy winter days in this city. Three large scale mirrors are used to bounce and bring winter sunlight into the valley. These gigantic mirrors track the sun, and reflect daylight downwards during the winter months [11] .

The sun mirrors are installed on the mountain at 742m over sea level in October 2013. They are approximately 450m above the Rjukan market square. Each mirror has an area of 17m². Collectively, they reflect a 600 m² (6,500 sq.ft) rays of sunshine into the town square. Computer-driven motors, control the orientation of mirrors that follow the sun's path to reflect the sunlight into the market square. The reflected light has almost 80-100% of intensity of the light that is collected at the mirror level [14].



Figure 17 - The mirrors are mounted to keep track of the sun [14].



Figure 18 - People cheer during an inauguration of the sun mirrors [14].

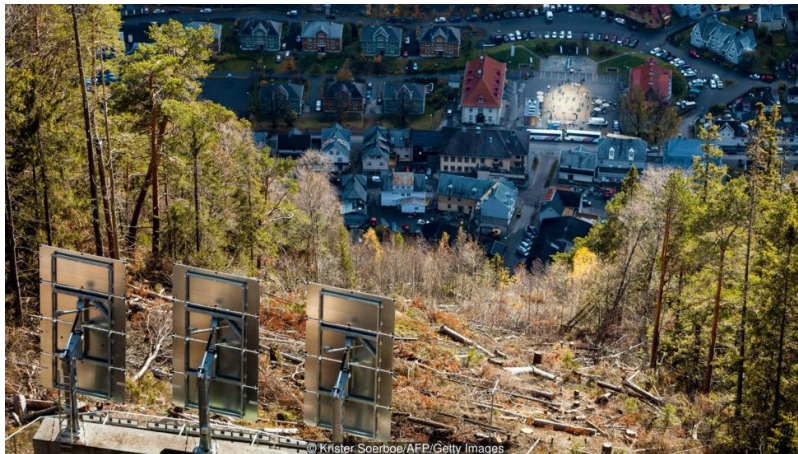

Figure 19 - Looking down on Rjukan, the path of the reflected sunlight [14].

2.1.2.6 Algerian Ksur

In contrast to the Norwegian city, Algerian Ksur illustrates a hot-arid city that relies on a dense urban layout that benefits from shadows. A compact settlement could provide a thermal comfort through dense overshadowing schemes. Overshadowing is one of the most useful strategies in the harsh environmental conditions. Due to the hot dry climate of Algeria, compact settlements have been utilized to provide passive cooling strategies. The strategies have three main levels: settlement planning, building design and building components [15].



Figure 20 - Mass plan of Ksar El Mihane in Djanet as a typical compact cellular layout

In contrast to the cities in mild climates that are organized in a disperse forms, the cities in hot climate of Algeria, are arranged in a compact cellular layout. The percentage of exposed external surfaces are reduced in such compact forms, and larger areas of shadowed outdoor spaces are provided throughout the day.

In hot dry climates, the main goal in selecting a building orientation is to minimize the impact of the sun on the façade throughout the summer months [16]. The main goal for the streets layouts is to facilitate maximum shading and minimum solar exposure for pedestrians and building facades

in summer months. In order to control the daylight, having small street width to building height ratio can secure the narrow streets with sufficient levels of shading. The north-south streets are narrow enough to make a mutual shading from morning to evening sun [17]



Figure 21 - Typical streets found in southern Algerian Ksur [15]

2.1.3 *Solar access practices at the street-level*

Providing solar access to public spaces can be a design criteria. Two contemporaneous designs utilize sunlight modeling to shape building form with urban-level considerations.

2.1.3.1 Lower Yonge District, Toronto, Perkins + Will

Perkins + Will's Energy lab has utilized sunlight modeling for a broad range of environmental factors. Their effect on design of new buildings are studied at an urban-level [18]. The analyzed metrics include the insolation, radiant heat and daylight availability levels inside the designed building. The evaluations concluded whether a space performance is satisfying based on the building's function (such as an office, a hospital, a school or a public space).

This method was used by the City of Toronto for the Lower Yonge district in the Toronto Waterfront. In this project, public access to the sunlight is emphasized. Tower Area Ratio (TAR) and Ground Floor Activation guidelines are depicted for a high-density area to secure sufficient exposure to the sky.



Figure 22 - Wide range of environmental factors were studied at the Lower Yonge District

[19]

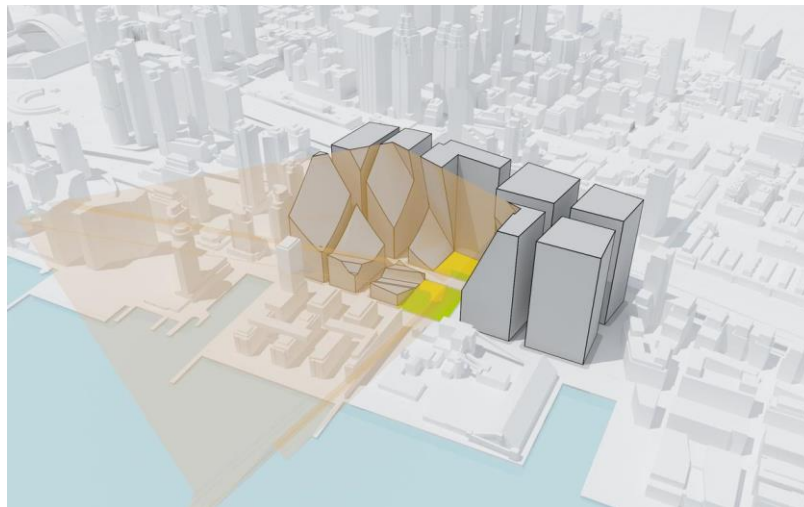

Figure 23 - Solar access modelling that in the lower Yonge District [19]

2.1.3.2 Solar Carve Tower, Studio Gang

Studio Gang has designed a glass tower that is “sculpted by the angles of sun” in the High Line district of New York. This project explores form finding in response to solar access criteria to a nearby urban park. This design workflow demonstrates the solar carving in a tall building context; where the building mass is shaped by tracking the sun over the site; building sections are removed from the cuboid form to increase the solar accessibility to the surrounding green space [20].

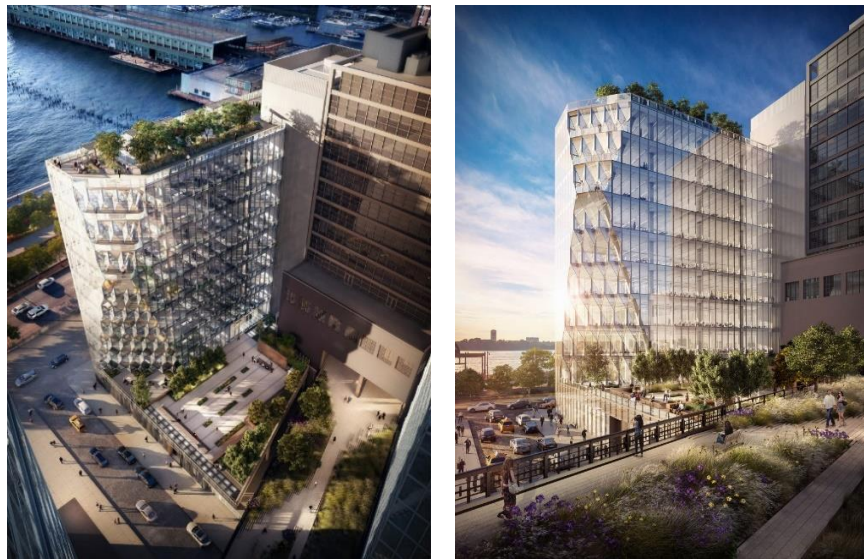

Figure 24 - Solar Carve Tower, Studio Gang [20]

2.1.4 Remarks

As discussed above, the traditional urban zoning approaches focus on maximum access to direct sunlight. The diffuse light (sky), weather patterns, and reflections from the environment are not considered. Most of the shadow diagrams are two-dimensional and demonstrate the overshadowing patterns at the street level. These approaches are not sufficient to facilitate successful daylight practices in interiors.

2.2 SOLAR RADIATION

There were a number of studies that utilize simulation-based approaches to calculate the (direct and diffuse) solar radiation on facades. These studies include the impact of weather, and the impact of the geometry and materiality of surrounding structures, when they are modeled accurately. However, they are most useful for analyzing design passive solar strategies and photovoltaic energy production. Although some of these studies are used as a surrogate to determine daylight availability [21], their usability is limited, as the depth of the building or the functionality of the space is not considered.

In 2004, Compagnon introduced a method to evaluate the daylighting potential of buildings by obtaining irradiance values on building envelopes in their urban context for passive solar heating, photovoltaic (PV), and daylighting [21]. He used diagrams to depict the relationship between façade orientation and solar potential. This method is a way to quantify sustainability metrics of urban massing models based on cumulative incident light and façade orientation [21]. However, this approach is only partially satisfying, since it does not consider that daylight accessibility in buildings is highly reliant on building depth [3].

2.2.1 *Insolation Factor*

The insolation factor is the ratio of solar radiation on a planar surface in comparison with the solar radiation received by the entire hemispheric radiating environment [22]. Polo Lopez et al. (2016) [17] presented methods to measure solar radiation, daylight availability and insolation factor in complex urban environment. They used numerical methods and simulation tools that combines photo processing techniques to project hemispherical environment onto a fisheye image to assess the insolation factor.

View of the sky and presence of daylight is important for human perception, comfort, and health. With this metric, presence or absence of solar radiation and the quantity of daylight in the interior environment can be studied. It is a way to quantify the solar access and the daylighting availability in the urban level throughout assessing the insolation factor metric. It is given a value between 0 and 1. A value of 0 shows a fully obstructed view and means that all the direct solar radiation will be blocked. A value of 1 indicates a non-obstructed view of the sky and means that all the solar radiation will be received [22]. However, its usability is limited to daylight availability and solar radiation at street level, but not at the building level, as the depth of the buildings and the penetration of solar radiation have not been considered.

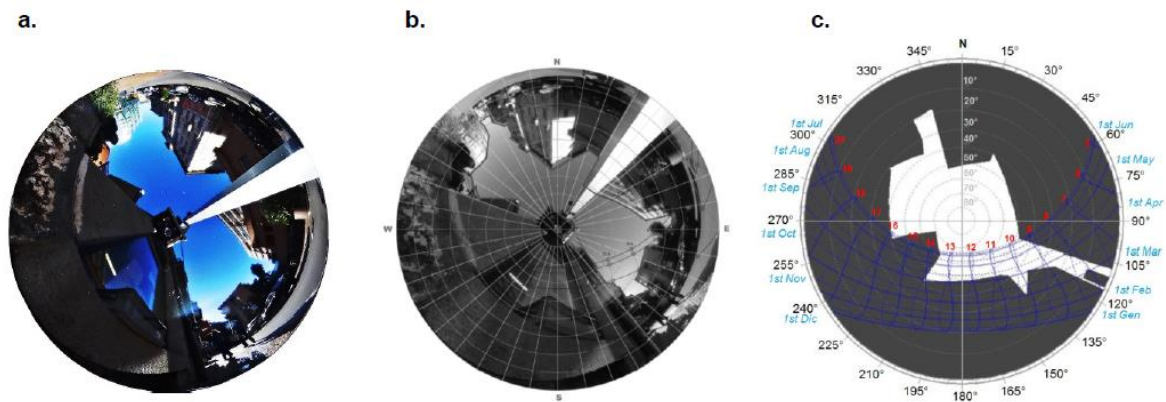

Figure 25 - Sky-factor assessment for building

Van Esch et al. [23] discussed the effects of urban and building design parameters on solar access and solar heat gains. Buildings with three different roof shapes, four different street width (10, 15, 20, and 25 m) and two different orientations were simulated in order to see the effect on solar access and solar heat gains. The simulation results illustrated that the street width had a significant impact on the global radiation in the canyon: wider the streets, higher the global radiation yield.

Decreasing the street width increases the shadows; and limits overheating problem in summer; and increases density in cities. However, increasing the street width may be preferable for maximizing the solar gains in winter months. Building envelopes solar exposure could be maximized in winter by choosing east-west street orientation, since the results showed radiation gain of buildings in east–west canyons is larger in winter in comparison with north–south streets. As discussed in 2.1.2.6, the preference could vary depending on dominant climatic conditions. This study includes the impact of weather, and potentially the urban geometry, building geometry from the roof design point of view. It is most useful to design passive solar strategies, rather than to determine daylight availability.

2.2.2. Remarks

As illustrated above, the studies that calculate solar radiation on envelopes include the impact of climate and the materiality, but they are usually applied to design passive solar strategies or energy production. These approaches are currently redundant as they were preferred when annual daylight models did not exist and viewed as computationally prohibitive. As the current daylighting computer models are accessible and sufficiently efficient, they negate the need to utilize insolation values as surrogate models for daylighting.

2.3 CLIMATE-BASED DAYLIGHT AVAILABILITY

More recent studies on urban planning concentrate on daylight availability and utilize climate based annual daylighting simulations in a given urban zone or block [24] [3]. This is a significant progress in comparison to previous approaches. However, there are two issues that require further research:

- a. It is prevalent to assume a constant reflectivity for outdoor surfaces (usually 30%). The importance of material reflectivity in urban canyon is gaining attention and research shows that it is typically underestimated [24] [5]. Additionally, many studies show that surrounding structures not only block but also reflect light, causing significant amount of reflected glare in some cases, depending on the building material and geometry.

In a recent research, Strømmand-Andersen et al [5]. considered building depth by evaluating urban canyons in section. It showed that the geometry of urban canyons (i.e. height to width ratios) has an impact on total energy consumption as much as +30% for offices and +19% for housing. It also aimed to identify the relationship between building scale, passive-energy components, and urban density. It was shown that the reflectance of surrounding buildings and ground surfaces could potentially increase the indoor daylight. Their workflow considered urban settings with uniform building height, and street sections with infinite extrusions. This approach does not account for high-density areas with different tower typologies.

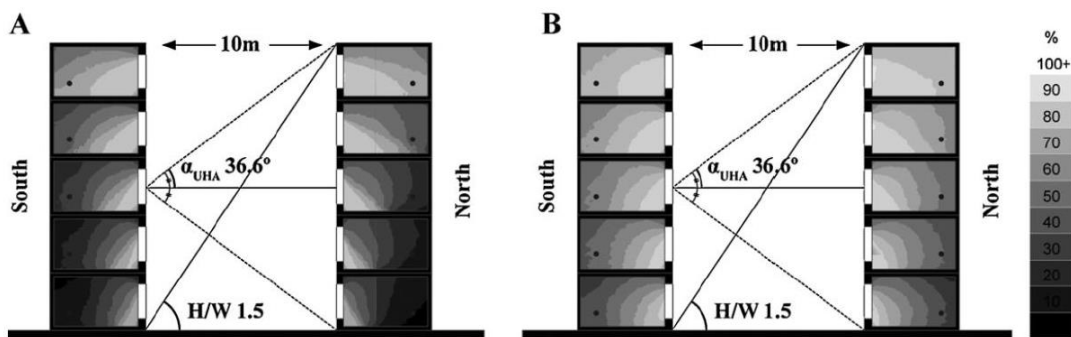

Figure 26 - Annual illuminance in street canyon with surface reflectance variables [5]

- b. The analysis criteria in climate based urban studies are either limited to daylight availability that achieves a target illuminance value. Any upper threshold to limit glare is not enforced; instead, it is assumed that the shading devices are operated at the building level with the assumption that glare is prevented as direct sunlight is not penetrated to the building interiors

[5]. This approach is based on an automated, ideal system that does not allow any sunlight indoor. In reality, some levels of sunlight penetration is permissible or desirable as long as sunlight does not reach to work surfaces or occupant's eye.

UD³ (abbreviation for Urban Daylight) is a new tool to simulate the daylight availability of urban master proposals [3]. This tool is a plug-in for Grasshopper, which itself is a plug-in of the Rhinoceros 3D modeler. UD follows a two-step simulation. In the first step, it simulates hourly solar radiation levels on all facades within its urban context using Radiance/Daysim simulation engines, and in the second step, external radiation levels are translated into interior illuminance distributions [3]. It considers a constant reflectance value (typically = 0.2), but it can be modified” in the Radiance geometry file that is exported to the simulation directory.

Cheng et al. [25] researched a 3D approach that investigates the interrelation between urban density, geometry and daylight availability by cross-indexing plot-ratio, site coverage, and daylight factor. Their research evaluated performance trends in relation to geometric features of the urban models. They used a randomized growth in vertical layout. This research demonstrates the advantages of using daylighting simulation in early urban design decisions. However, the scope is limited, and the daylight metric that was used in the study is not a climate-based metric.

Given the desire and pressure for densification in rapidly growing urban areas, this approach is successful as it considers the potential benefits of urban growth in controlling glare in urban level. For indoor daylighting, it is better to study the urban layout not only to provide access to target daylight levels, but to limit the daylight illuminances to prevent glare. Instead of randomized growth as suggested by Cheng et al. [25], it may be possible to suggest a controlled development

³ Urban Daylight Simulation

approach to prevent glare in surrounding buildings. Preventing all direct sunlight to interiors is problematic and undesirable. Due to the functionality of the indoor space, glare control threshold could be varied. Office spaces require high glare control. However transitional areas and other gathering spaces in offices would benefit from high luminance areas to support health circadian rhythms. In residential units, cheerful effects of sunlight might counterbalance the desire for strict glare control practices.

Saratsis et. al. [17] introduced a workflow by using UD⁴ tool to assess the daylight efficiency of various urban massing models. Their research focuses on 50 urban-scale models with different typologies, and develops guidelines for performance-based zoning laws. They compare density and daylight accessibility based on IESNA LM83 / LEED v4 criterion sDA [300 lux] [50%]. It is suggested that municipalities may use this workflow to derive prescriptive daylight zoning laws for their early urban massing decisions. However, as noted above, the UD tool considers a fixed material reflectivity and daylight analysis criteria are restricted to achieving a minimum illuminance value, and automated shading devices are operated at the building level to filter out all sunlight to prevent glare.

Laws requiring sunlight access to buildings are simplistic, at best, when we are aiming for the successfully designed daylit interiors. They are useful for the design of urban outdoor spaces. There is a need for a refined simulation and evaluation workflow at the urban scale, along with performative daylighting designs at the individual building and dwelling scale. The simulation approach should require a deeper understanding than simplified approaches that are traditionally employed.

⁴ Urban Daylight Simulation Tool

2.4 WHAT ARE THE METRICS FOR URBAN DAYLIGHT SIMULATION FROM THE PAST TO PRESENT?

For daylight simulations, the following metrics have been used in the existing urban daylight simulation:

- Geometry-based investigations
- Radiation-based investigations
- Illuminance-based investigations

2.4.1 *Geometry-based investigations: Sky view factor (SVF)*

As discussed earlier, solar envelope is a sun-based investigation design tool described by Ralph Knowles [9] which creates the largest buildable volume that will not shade its neighbors for a specified period of time throughout the year. Figure 27 shows a typical city block with two alley (20' width) that use the solar envelope concept.

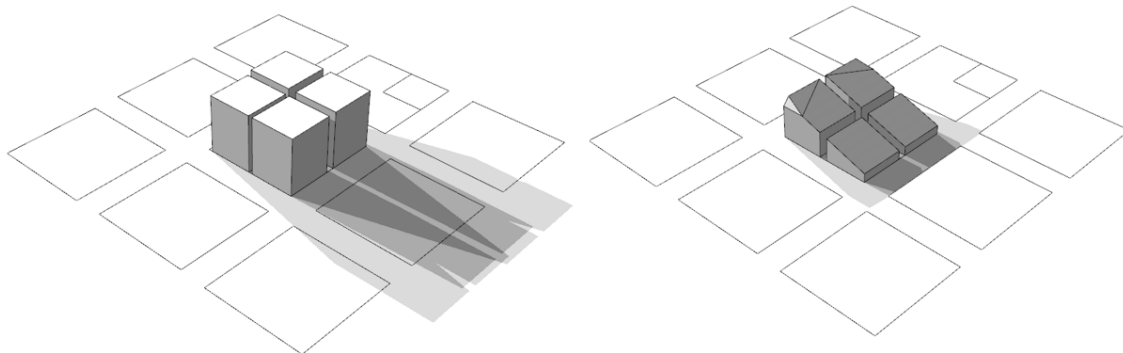

Figure 27 - The solar envelope design provide building (right model) that does not shade its neighbors in 11-13 pm December 21 in this model. (Location: Seattle)

Concepts such as Sky-view Factor (SVF) [26] can be effectively utilized to study access to sky (not just the sun). Sky view factor (SVF) is a metric that is directly dependent on the height of

buildings and the distance between them (Figure 28). These dimensions have a significant impact on the daylight availability of buildings [22].

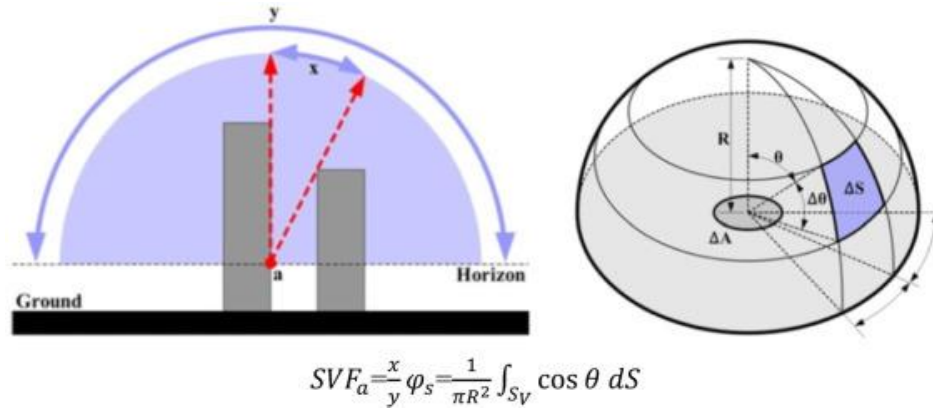

Figure 28 - Measuring Sky View Factor

The sky hemisphere and sun path diagrams can be used to determine overshadows of surrounding urban fabric at a given point. If we imagine a hemisphere that surrounds a focal point in a specific site (representing the angular relation of the sky dome with the given point), areas of sky blockage with the neighboring structures are determined by projecting lines from the focal point to the each vertex of the surrounding structures. The silhouettes of the structures are derived from the intersecting lines on this imaginary hemisphere, and they determine the sky blockage. If the silhouettes coincide with the sun-path diagram, they provide sun blockage at the given dates and times on the sun-path diagram. Any area in the resulting sun-path diagram represents an area of solar shading on the focal point, where a surrounding object would block direct light from the sun, when it is behind the object (Figure 29).

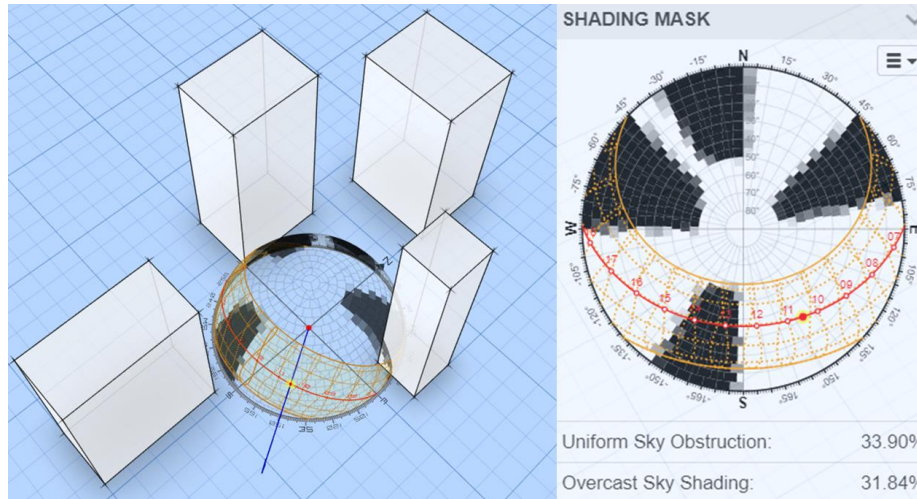

Figure 29 - Dynamic overshadow simulations [27]

Sky-view factor (SVF) can be measured using digital cameras with fisheye lens. It is possible to analyse the sky view obstructions by calculating the geometric coverage from these images. Analyses obtained from photographic techniques are similar in concept with simulation-based applications [27], where dynamic overshadow sun-path diagrams can be derived from 3D models.

2.4.2 Radiation-Based Investigations: Incident Solar Radiation

It is essential to consider a radiation-based metric for any building that is concerned with energy efficiency issues. Solar radiation is converted to heat, if it penetrates into a building; or electricity, if a PV array captures it. The intensity of solar radiation varies with the atmospheric conditions, and the angle at which the rays strike a surface (i.e. incidence angle). The intensity of solar rays are reduced in proportion to the cosine of the incidence angle, as the rays deviate from the surface normal.

Incident solar radiation (insolation) is the amount of solar radiation energy reaching a unit surface area at a given time. Values are given in units of energy per area (W/m^2 or $\text{BTU}/\text{hr}/\text{ft}^2$). It can also describe the accumulated energy per day or year (kWh/m^2 /day or $\text{kWh}/\text{m}^2/\text{yr}$).

This metric is used for urban planning approaches and focus on maximum access to direct and diffuse sunlight. It is useful to study urban heat islands, passive solar heating strategies, and PV energy production. The radiation-based metrics were mainly preferred when annual daylight metrics did not exist. As the annual illuminance-based metrics are accessible now, the insolation metrics is redundant for investigating indoor daylight availability.

2.4.3 *Illuminance based Investigations*

Historically daylight factor was used as a common metric for daylight analysis. Daylight factor is the ratio between indoor illuminance and outdoor illuminance. It is calculated only under the CIE overcast sky conditions. An overcast sky does not take into consideration of solar position. Sun is not visible from the heavy cloud cover, therefore, discomfort glare from direct sun penetration cannot be assessed with overcast sky conditions. Overcast skies are symmetric in plan view, as a result, rooms with different orientations will receive the same amount of daylight penetration. Design decisions based on daylight factors will result in excessive daylight levels under clear sky conditions.

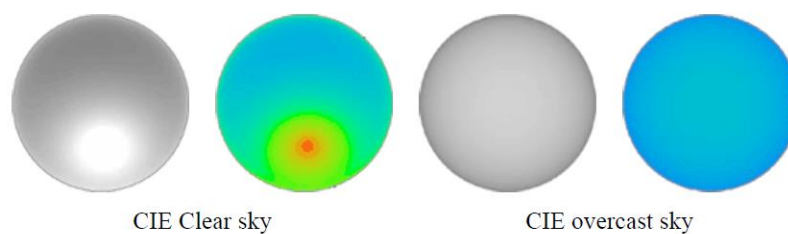

Figure 30 - CIE sky conditions [28]

2.4.3.1 Annual Climate- based Daylighting Simulations

In climate-based lighting simulation, recorded climate data for a location is used to simulate the sun and sky conditions for the entire year. Perez all-weather sky model [29] is used to generate skies from direct and diffuse solar radiation values. Performing point-in-time calculations for approximately 4000 daylight hours throughout the year is computationally expensive; the process is accelerated using Daylight Coefficient methodology [30] [31] [32]. Calculated annual illuminances are reported with metrics as discussed below.

Daylight Autonomy (DA)

Daylight autonomy (DA) quantifies the percentage of hours during a whole year that the daylight levels exceed a given target value [30]. The minimum illuminance levels for different spaces can be directly derived from reference sources such as the IESNA Lighting Handbook (Office 200-300 lux) [33]. With this percentage, it can be understood that the minimum illuminance threshold is achieved or surpassed during the occupied daylight hours. The Continuous Daylight Autonomy (cDA) is defined similarly to daylight autonomy, but it gives a partial credit to the illuminance level under the minimum illuminance threshold [34]. Therefore, this metric moderates the “transition between compliance and non-compliance” [30].

Useful Daylight Illuminance (UDI)

Useful Daylight Illuminance encapsulates the range of illuminances that constitute useful levels of illuminance for human activities [35] [36]. The suitable range for human comfort zone is considered to range between 300 to 3000 lux.

- *UDI not achieved (or UDI-n)*: refers to the percentage of the year that the illuminance is less than 100 lux. For this period, electric lighting is necessary.
- *UDI supplementary (UDI-s)*: refers to the percentage of the year that the illuminance is greater than 100 lux and less than 300 lux. For this period, additional electric lighting *may* be needed to supplement the daylight for common tasks such as reading.
- *UDI autonomous (UDI-a)*: refers to the percentage of the year that the illuminance is greater than 300 lux and less than 3000 lux. For this period, additional electric lighting is not needed and visual discomfort is not observed.
- *UDI exceeded (or UDI-e)*: refers to the percentage of the year that the illuminance is greater than 3000 lux. It indicates the period when discomfort glare is present.

Average Annual Illuminance

Average Annual Illuminance quantifies average point-by-point illuminance over a horizontal calculation grid. Average Annual Illuminance represents an illuminance value over a whole year, but the numbers are averages, and they cannot inform about the maximum and minimum values, or the temporal variability throughout the year. Average Annual Illuminance can be quantified by post-processing results from annual simulations. This metric can be useful at the early stages of the design as it can depict an evaluation of daylight potential, general daylight levels, and spatial distributions of a space [31].

Spatial Daylight Autonomy (SDA)

The Spatial Daylight Autonomy (sDA) [37] measures how much of a floor area receives daylight autonomy (>300 lx) for at least 50% of the occupancy hours. Thus, it includes a percentage to show whether a space can be considered daylit [38].

Annual Sunlight Exposure (ASE)

The Annual Sunlight Exposure (ASE) measures how much of a floor area receives direct light above a minimum threshold (typically 1000 lx) for more than a certain number of annual hours (typically 250). sDA along with the ASE is used in LEED v4. An $aSE_{1000lx, 250hrs}$ score of no more than 10% for regularly occupied floor areas is necessary for a daylighting credit [4].

Spatial Daylight Autonomy (sDA) is used to assess daylight availability and Annual Sunlight Exposure (ASE) is used to assess and decrease potential glare issues.

A comparative analysis of most of the mentioned climate-based metrics is illustrated in Figure 31.

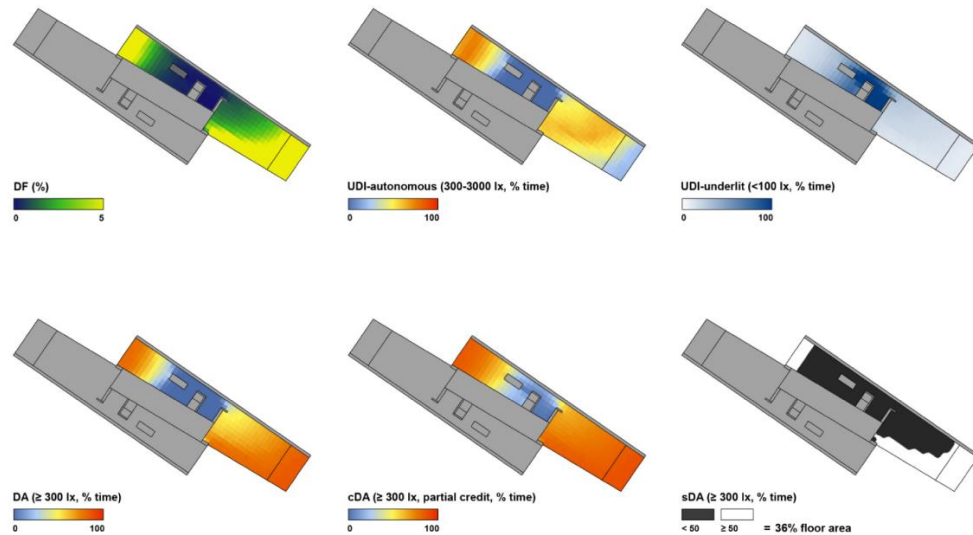

Figure 31 - A comparison of common supply-focused daylight performance metrics (DPMs).
Climate: Berlin. Occupancy: 8AM-6PM [38]

Chapter 3. METHODOLOGY

Chapter 2 provided a literature review on analytical daylighting approaches to urban form and canyon. This chapter focuses on methodology, which is described in two sections as setting and workflow.

3.1 SETTING

An objective of this research is to develop a methodology to evaluate successful daylighting approaches within the context and the scale of urban layouts. The research is conducted on Seattle business district. Based on the development capacity report of 2035 [39] , Seattle is expected to receive high density development in the next 20 years:

Washington state and the regional agencies evaluate that there would be an increase of 20% in population and 23% in jobs. To adjust this increase, the City is modifying Seattle's Plan to be shaped for this growth. The City decisions are based on a 20-year roadmap for Seattle's future growth. The City studies new policies based on a variety of data to evaluate the future growth trend and to plan the development capacity. [40]

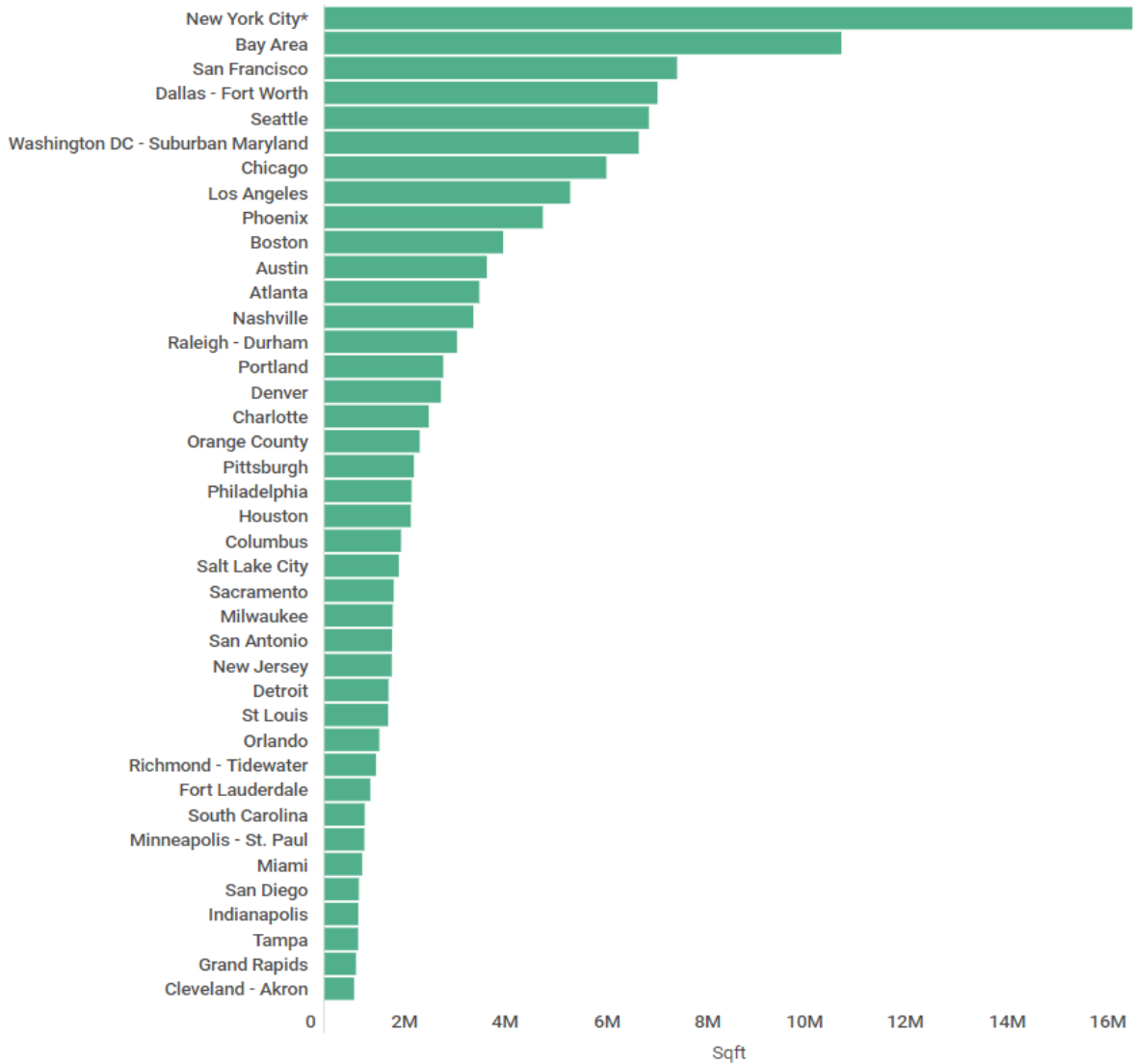

Figure 32 - Top 40 U.S. Markets for Office Deliveries in 2019 [41]

These findings indicate that there is a need for updating the current zoning rules to accommodate the future growth. The proposed workflow can be used to evaluate the limitations of existing urban zoning rules. However, it is important to note that the scope of the research is not to develop and propose the new zoning rules. The scope is to provide an adequate workflow for urban scale daylight evaluation, and to suggest alternative layout and building mass patterns, and façade strategies that can provide better daylighting in office buildings in dense urban areas.

3.2 WORKFLOW

The workflow is based on daylight parametrization and simulation of generic urban scale models; each model represents a specific combination of built form and density (Figure 33).

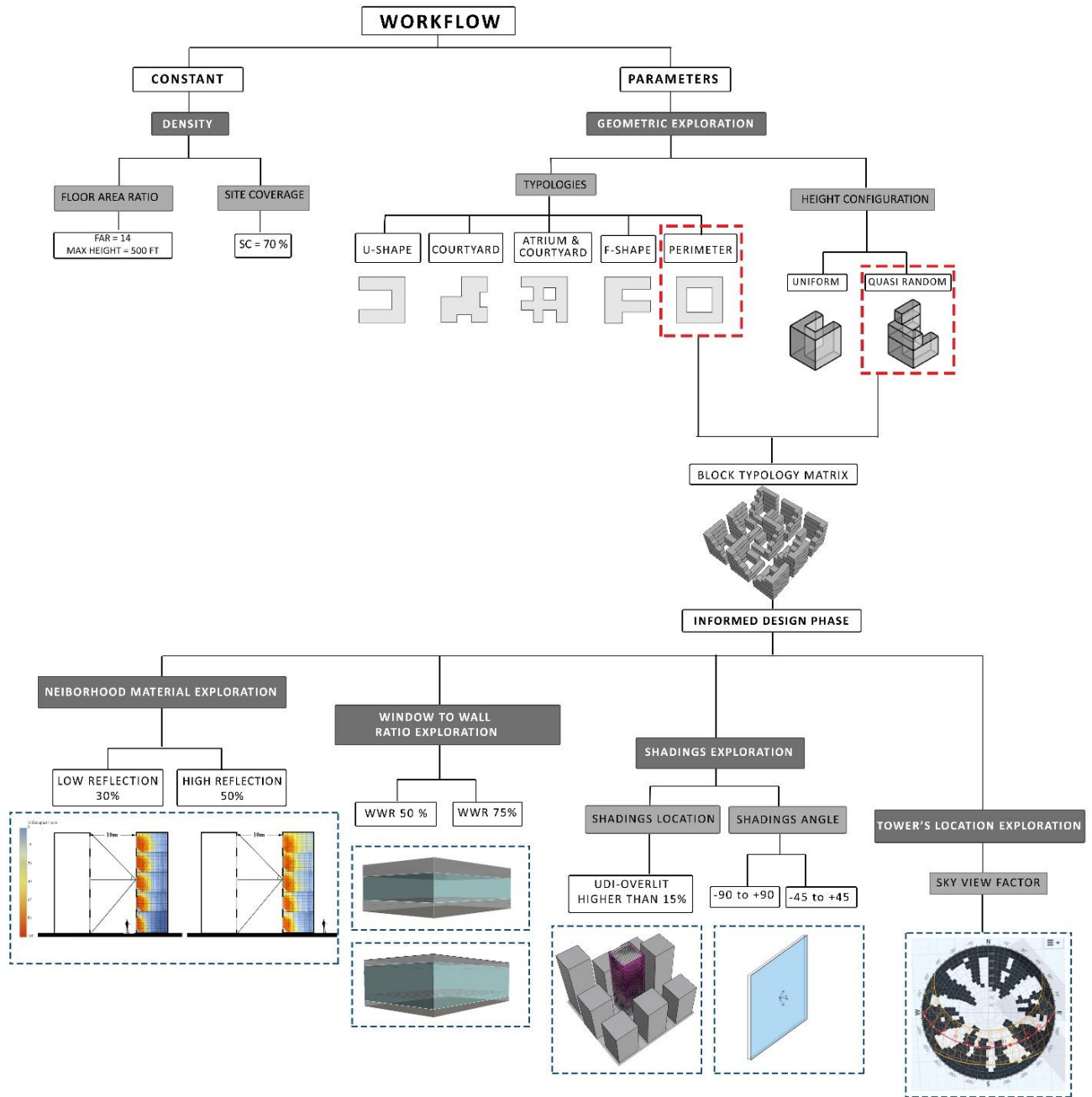

Figure 33- The summary of the proposed workflow

The relationship between geometries, density and daylight potential are investigated with the following three design criteria:

- The formal investigations consist of using different typologies (Figure 34).
- Vertical configuration investigations consist of varying the building height in three settings: uniform, random and informed design height distributions (Figure 35). In “uniform” typology, height is assumed to be equal in all building masses. “Random typology” is a quasi-random variation of building heights. The informed design is based on changing height distributions in a thoughtful manner using solar and geometric data.
- Densities are evaluated using the metrics of floor area ratio (FAR) and site coverage. FAR is the ratio of a building’s total floor area to the total area of the lot, on which the building is built.

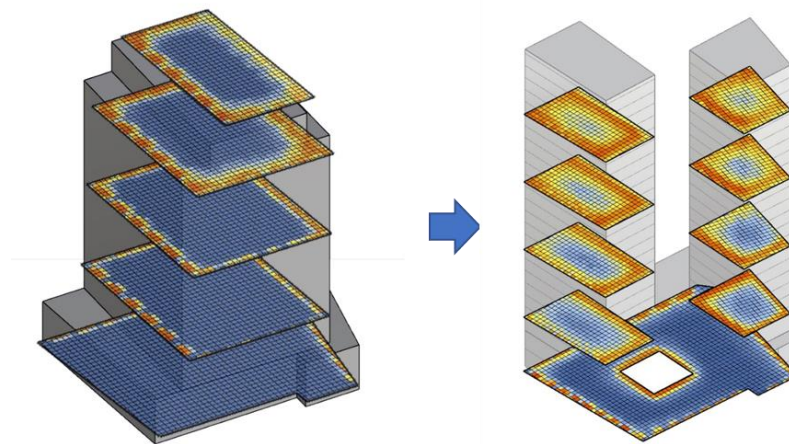

Figure 34 - Comparison of daylight availability in two massing designs. In the new massing proposal, better daylighting scheme is achieved at all floors of the building.

predesignated to incorporate concentrated employment growth. They are exempt from the development standards of adjacent lots that permit incorporation of residential projects. In these zones, commercial development is a preferable. It is not necessary or feasible to apply the standards relevant for better residential development to the high-density commercial projects [42]. In developing the generic models, FAR and site coverage are defined based on the existing DOC in Seattle. In the simulation, building arrays were uniformly laid on a site of 852 feet by 840 feet. The site is divided into nine blocks, and the middle block is investigated. The street width in between the blocks is 66 feet based on a typical street width in this zone. The models have the same FAR (FAR=14), and the same site coverage (70 %). Figure 37 illustrates the generic site with the uniform plan.

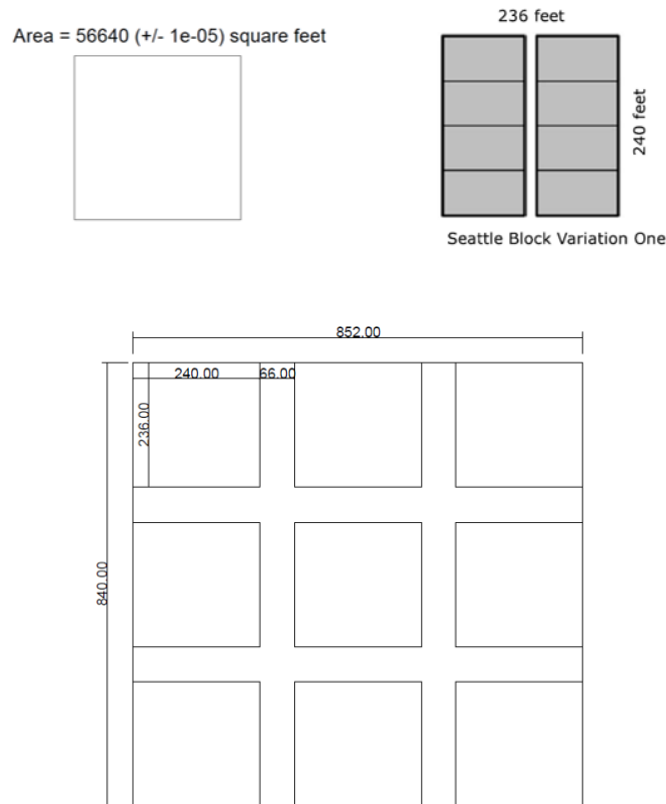

Figure 37 - Typical Seattle block module (Left), Virtual site (Right)

3.1 SIMULATION SETUP:

DIVA for Rhino and grasshopper simulation software [2] is used for the dynamic simulations of indoor illuminance. DIVA simulations are based on validated environmental performance engines including Radiance [43] , Daysim [44], and EnergyPlus [45]. Diva incorporates annual hourly weather data, building and urban geometry, physically plausible material properties to perform reliable and fast dynamic illuminance simulations.

The first metric that is computed in DIVA simulations is Useful daylight Illuminances (UDI) [35]. The UDI (300-3000lx) range is selected among all other climate-based lighting metrics (discussed in Chapter 2). UDI provides the desirable lighting range with a minimum threshold to avoid underlit conditions, and a maximum threshold to avoid discomfort glare. The UDI is measured on a “4 foot” spaced grid at desk height. Sky View Factor (SVF) [26] is utilized in early geometry-based evaluations.

In the simulation process, five parameters are explored:

- Geometry
- Material properties
- Window-to-wall ratio
- Shadings
- Tower location variability

3.1.1 *Geometric Exploration*











In this study, five generic typologies with different urban plan footprints are represented. The footprints of the five generic typologies at the ground level are as follows and illustrated in Figure 38: i) U-shape; ii) courtyard; iii) atrium and courtyard; iv) F-shape; and v) perimeter.



Figure 38- The footprint of the generic geometries at ground level -Typologies inspired from a previous study [46] for lot coverage

Although there is no limitation in the massing distribution in this zone, the minimum massing width considered is 50 feet. As mentioned earlier, these cases correspond to different vertical layouts, ranging from **uniform, quasi-randomized to informed-designed**. The first two groups are depicted in Table 1. In this phase, the height configuration is formed based on the distance to neighbors and their height.

Table 1 - Summary of cases being studied

VERTICAL CONFIGURATION		
	UNIFORM	QUASI- RANDOM
BASE GEOMETRY		
CASE 1- U SHAPE		
CASE 2- COURTYARD		
CASE 3- ATRIUM & COURTYARD		
CASE 4- F SHAPE		
CASE 5- PERIMETER		

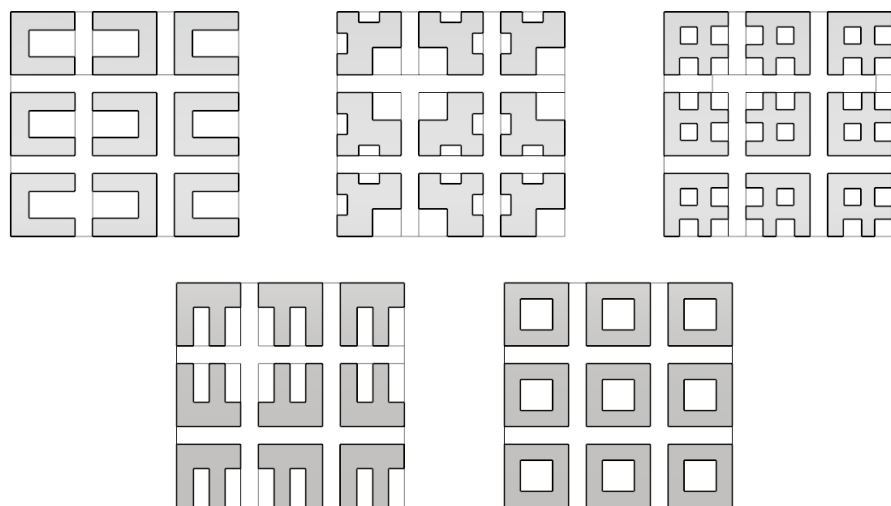

Figure 39 - Block typology evolution matrix

A 3D model is created based on the defined FAR and Site Coverage. The parametric model allows variations for the Window-to-Wall Ratio⁵. The model includes layers for roofs, floors, walls, windows, and surroundings. The minimum depth of the floors is 55 Ft. The maximum height of the building is set to 500 ft based on the zone requirements.

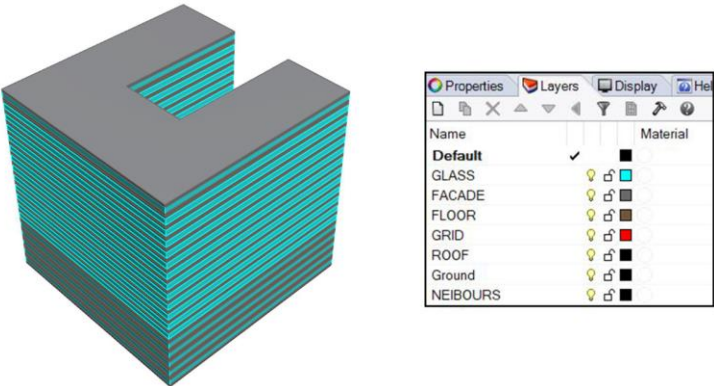

Figure 40 - 3D Model with different layers

Figures 41 and 42 displays the differences among these typologies. Typologies with random vertical distribution yield to average block heights that are higher than the uniform cases.

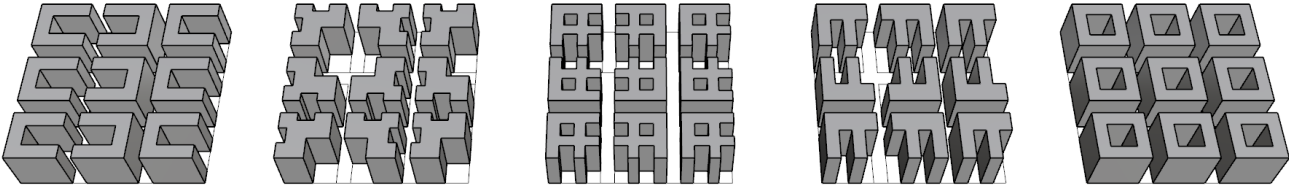

Figure 41 - Five cases with uniform height distributions

⁵ The **window-to-wall ratio** is the measure of the percentage area determined by dividing the building's total glazed area by its exterior envelope **wall** area.

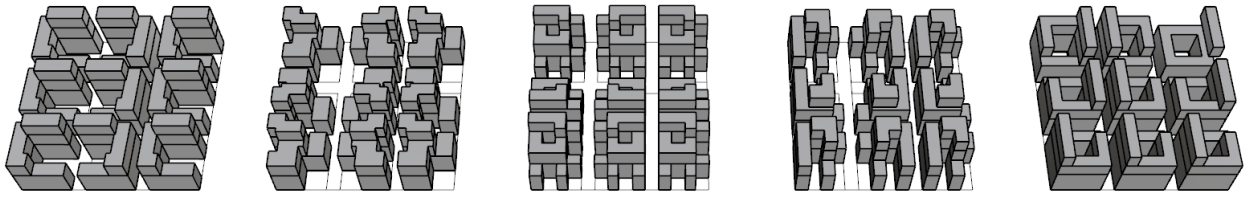



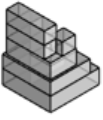
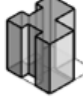













Figure 42 - Five cases with random distributions

In the first quasi-random distribution iteration, the results reveal that there is not much variation in the lower floors. A second quasi-randomized configuration is designed to provide more variations in massing distribution. In random cases, the average heights of the blocks are higher than the first random one. In all cases, the FAR and site coverage remained the same. The minimum depth of floors is 65 ft. (Table 2)

Table 2 – Summary of cases being studied (The second quasi-randomized configuration provides more variation in massing distribution)

VERTICAL CONFIGURATION			
	UNIFORM	RANDOM (1)	RANDOM (2)
BASE GEOMETRY			
CASE 1- U SHAPE			
CASE 2- COURTYARD			
CASE 3- ATRIUM & COURTYARD			
CASE 4- F SHAPE			
CASE 5- PERIMETER			

3.1.2 *Material Exploration*

Opaque materials are set to plausible generic surface reflectances as follows: ceiling 70%, white interior walls 70%, floor 40% and neighboring buildings 30% to 50% diffuse reflectivity. The glazing in the model is a double pane low-E glass with 65% transmissivity (Fig 43).

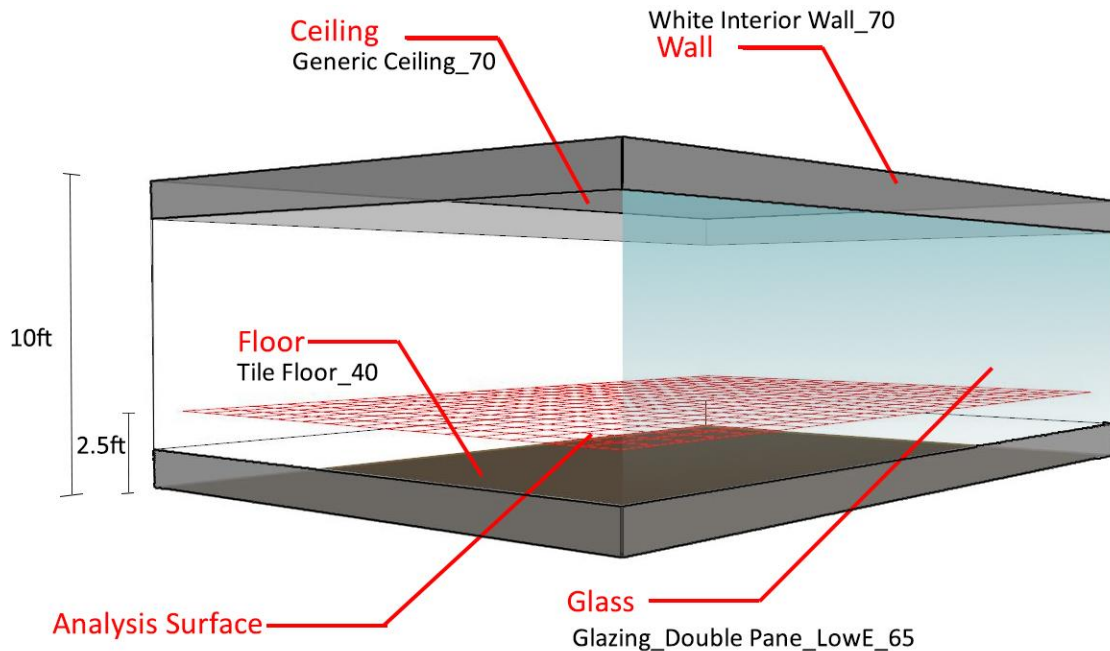

Figure 43 - Simplified model with assigned materials

Reflectance from the surrounding buildings affect the daylight distribution inside the buildings. In Figure 44 case A, the simulation was done on a model with low-reflectance materials, which is defined by the standard value for this urban district. Street canyon surface reflectance values for the ground surfaces and the external walls are 20% and 30%, respectively. The second simulation (case B) was done with high reflectance materials (70% reflectance for the external walls, ground surfaces remained at 20%). The results clearly show that the useful daylight levels significantly increases on the ground floor of case B, in comparison to A. In case B, the level of daylight would be enough to do perform most common visual tasks without a need for electric lighting. Thus, one of the parameters that can be considered in the transition from quasi-randomized to informed-designed phase is material reflectivity.

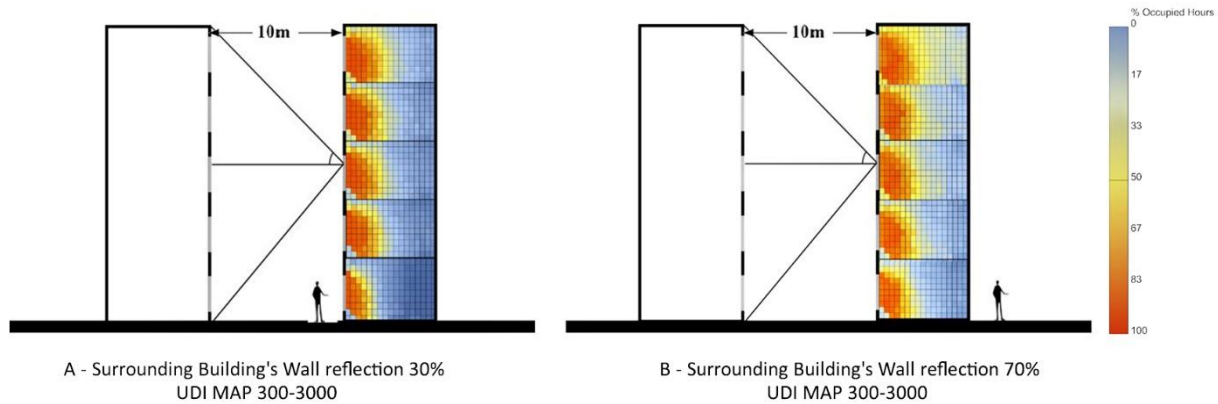

Figure 44 - Section of an urban canyon with different reflectivity levels

3.1.3 Window-to-wall Ratio Exploration

In the initial setup, the Window-Wall-Ratio is defined as 50%. Generally, window-to-wall (WWR) ratios do not exceed 75%, even in an all-glass building (25% of the glass is insulated spandrel glass covering floor structure, ceiling plenums, and etc. as shown in Figure 45). Daylight availability in the building can be increased when the window-wall ratio is also increased. In this study, the impact of increasing the WWR on useful daylight illuminance is studied, since it is predictable that by increasing the WWR the glare value will be also increased. In the informed-designed phase, window wall ratio is increased to 75%.

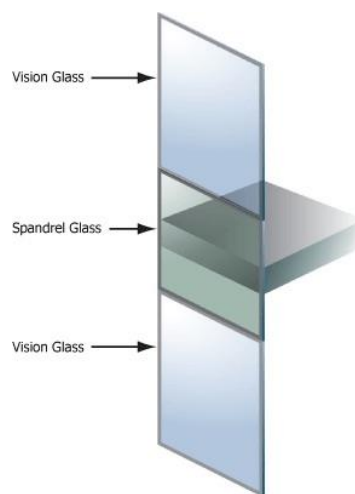

Figure 45 – The spandrel glass is covering floor structure, ceiling plenums [47]

3.1.4 Shadings Exploration

DIVA can simulate windows with automated shades; and it is possible to calculate and visualize the percentage of occupied hours that the shades are open. When a dynamic shading system has been defined, it is considered during an annual climate-based metric calculation, and the openness of the shading system is displayed over the entire year. DIVA is set to use the roller shade as a dynamic shading system (Figure 46). Dynamic Shading Devices with the DIVA advanced shading module in Grasshopper has two different options:

- Manual Control sensors
- Automated control sensors



Figure 46 - Roller Shade [48]

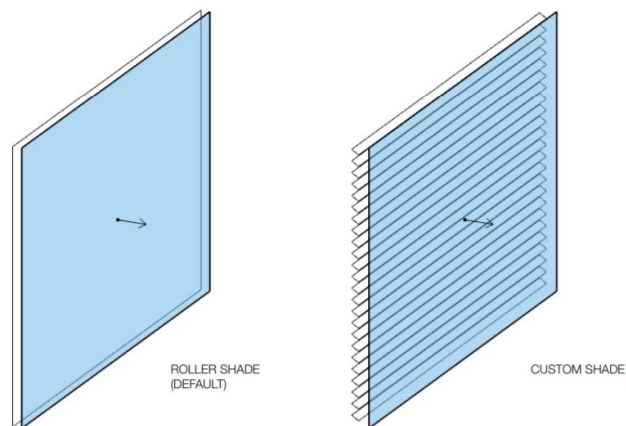

Figure 47 - Diva: roller shade & custom shade system

3.1.4.1 Manual control sensors:

In manual control, each window has its own shade, and each shade has its own sensors distributed in an area of coverage. The sensors dictate whether or not the shade is deployed or retracted, based on the light levels. The sensors are placed on the grid; and their location is defined by the dimension of the grid and how frequently the sensors are positioned. This is equivalent of simulating human occupants responding to sunlight in their work area.

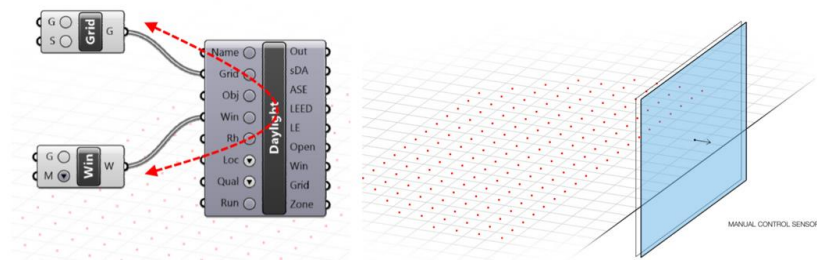

Figure 48 - Manual control sensors

3.1.4.2 Automated control sensors:

In automated control mode, the shades are closed when a threshold number of sensors are hit by the direct sunlight. It is possible to override the sensor position(s) and threshold as necessary. Sensor coverage angle for horizontal and vertical fields of view can be adjusted from -90 to +90 degrees.

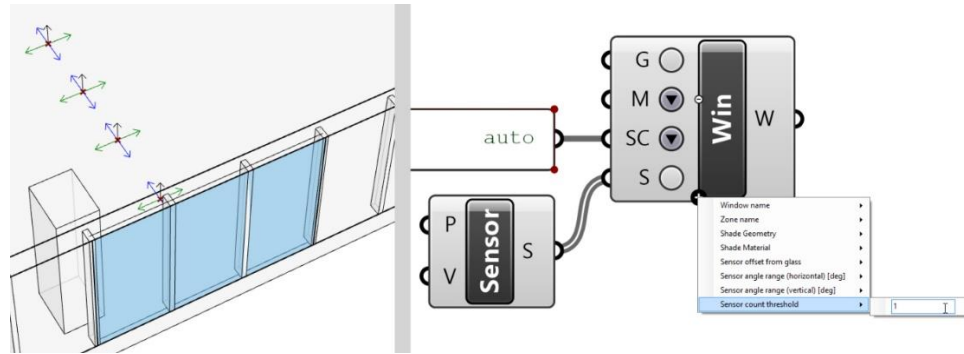

Figure 49 - Automated control sensors

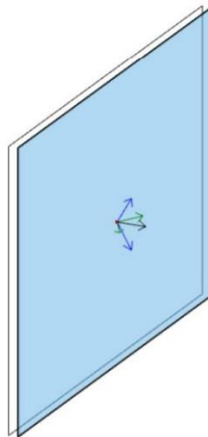

Figure 50 - Automated control sensor angle -90° to $+90^{\circ}$ (Horizontal and Vertical)

In this study, automated shading is selected as the shade module. It is applied only for those floors that have a glare problem. If the UDI-overlit is higher than 15%, then the automated shadings are applied for the windows. For instance, the automated shadings are applied to the 8 upper floors of a 34-floor building in Figure 51. In informed design phase, the automated control sensor angle is defined as -90 to $+90$, and then it is limited to -45° to $+45^{\circ}$ to have narrower field of views to see how it can affect on shadings performance.

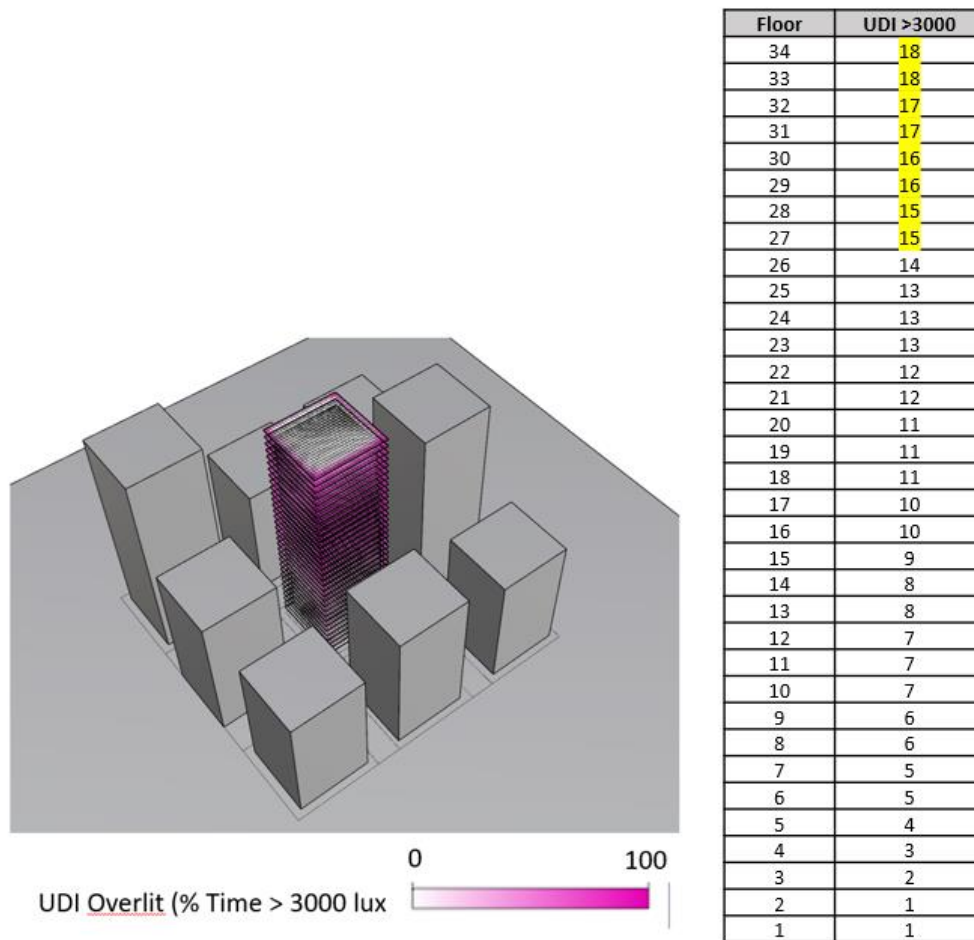

Figure 51 - If the UDI-overlit is higher than 15 % of the year during daylight hours, then the automated window shading system is deployed

3.1.5 Tower's Location Exploration

In the informed design, finding a proper location and orientation for the towers is one of the essential parameters to be considered in massing distribution. The SVF [27] metric is used to facilitate decisions on the geometric formation of the towers in informed design phase. Eight points are marked around the studied block to analyze the SVF percentages (Figure 52). This information is useful to determine the location of the tower; less sky obstruction is preferred to avoid under-lit building interiors.

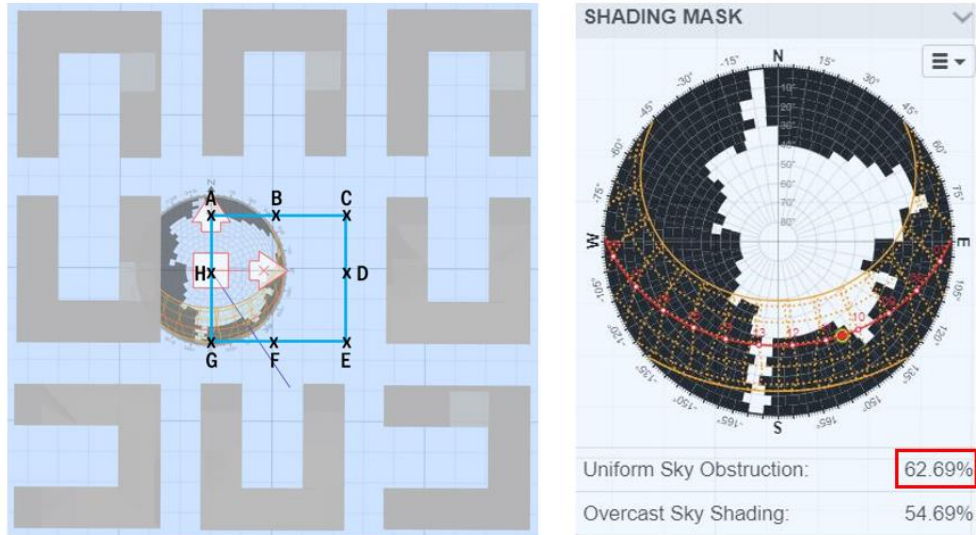

Figure 52 - Defining eight points around the site to obtain the SVF percentage

Points	Sky Obstruction
A	58%
B	56%
C	58%
D	60%
E	61%
F	62%
G	62%
H	63%

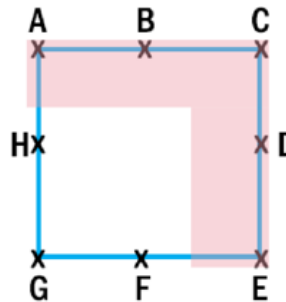

Figure 53 - SVF percentages in the proposed locations of towers

Chapter 4. RESULTS

4.1 SIMULATIONS FOR THE UNIFORM HEIGHT CONFIGURATION

The first set of UDI simulations are performed for the uniform height typologies for each floor. As it is predictable, there is a constant decline in the daylight availability for the lower floors in all the typologies due to greater sky obstruction from the surrounding buildings (Figure 54). While all of them is showing a higher level of UDI on the top floors, the levels are insufficient even for the upper floors. For the original geometry, the average UDI(300-3000) is 14%, i.e. only 14% of the year during daylight hours, the daylight levels are satisfactory. Daylight levels are not sufficient for 82% of the year to do common visual tasks. 3% of the year, glare problem is present. Table 3 presents the average UDI percentage for all the typologies. The values are an average of all floors. There are not many variations for the value of the UDI between all the typologies. However, there is a noticeable difference in the UDI percentage among the original geometry and the typologies created in this study. This shows that the footprint of a building has an impact on daylight availability levels inside the building. Predictably, the results reveal that the main problem is lack

of daylight even in upper floors since the daylight cannot penetrate deep into these large floor plates. The under-lit problem is worse in lower floors due to high-density urban surroundings.

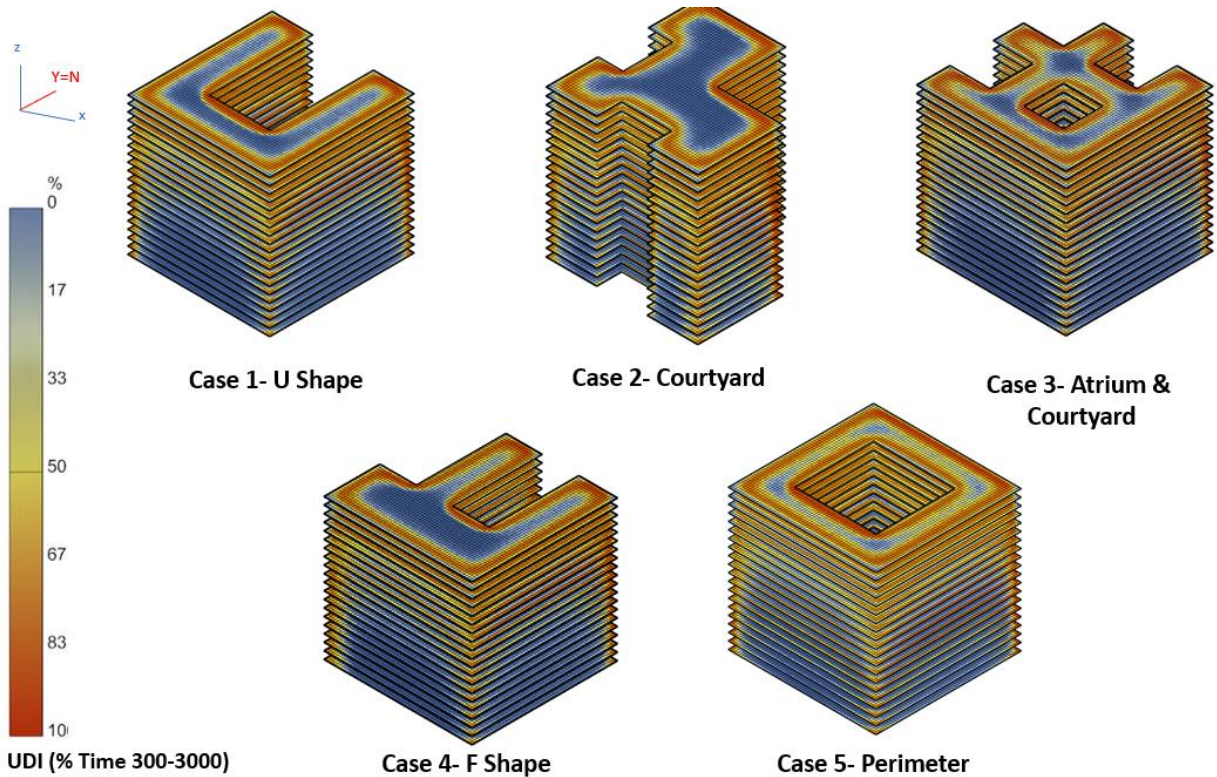
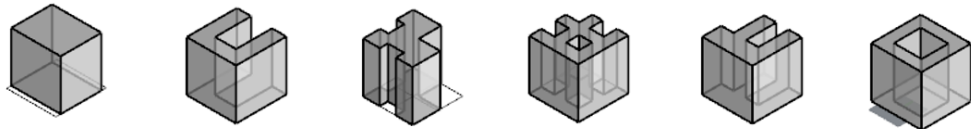

Figure 54 - Uniform height typologies with individual floors UDI (300-3000) map

Table 3- Uniform height typologies - UDI results



Uniform	Original Geometry	1 U Shape	2 Courtyard	3_Atrium & Courtyard	4 F shape	5 Perimeter
UDI 300-3000	14%	21%	20%	23%	20%	22%
UDI <300	82%	74%	75%	72%	75%	73%
UDI >3000	3%	5%	5%	5%	5%	4%

4.2 SIMULATIONS FOR THE QUASI-RANDOM HEIGHT CONFIGURATION

In quasi-random height mode, the height distribution is not uniform, and some variations are provided in massing distribution. Table 4 represents the average UDI percentages for all typologies. Figure 55 shows a visualization image presenting the quasi-random height configuration with individual floors false-colored with UDI values.

The increase in useful daylight level is not significant. The difference between typologies is limited to few percentages. Table 4 demonstrates the UDI (300-3000) percentages as an average of all floors. To better understand why these results have been achieved, Table 5 shows the UDI (300 – 3000) percentages for each floor.

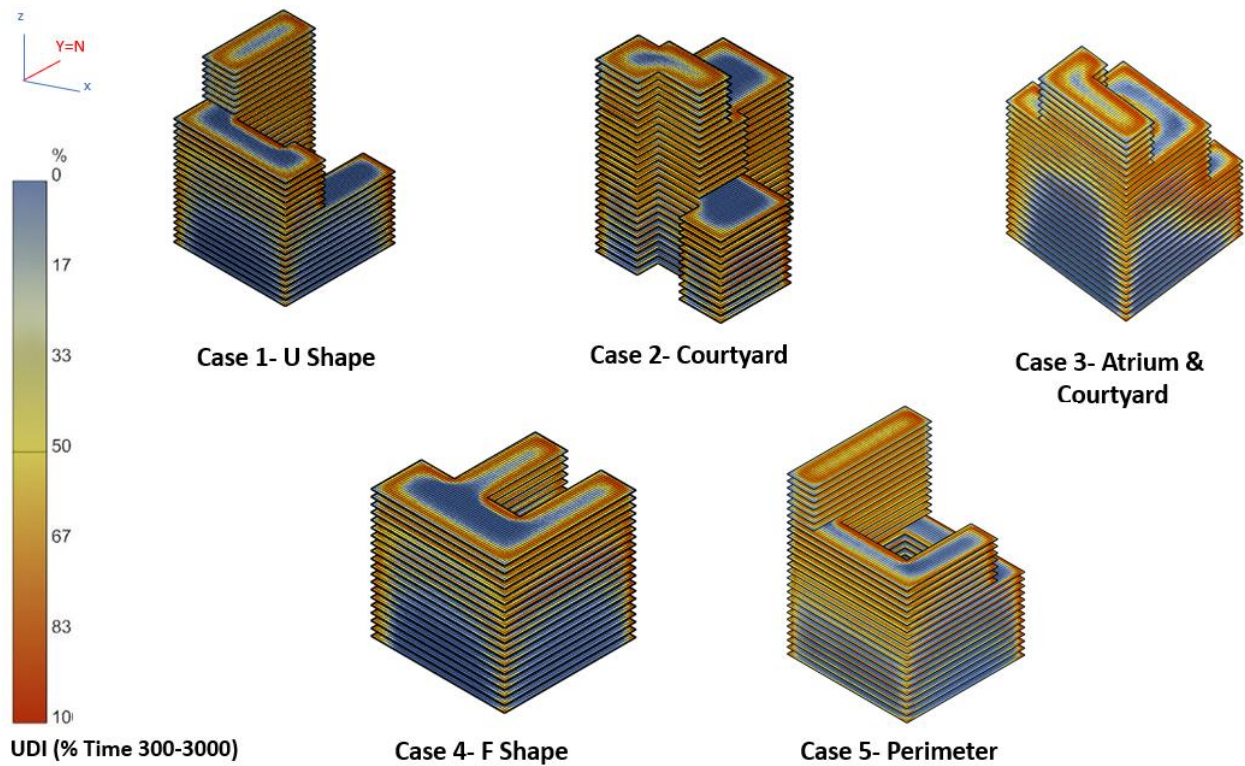
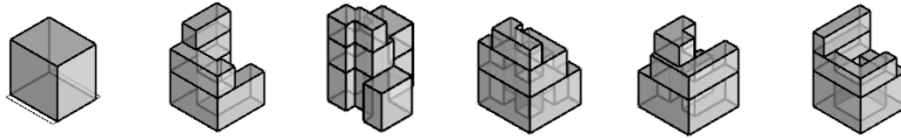

Figure 55 – UDI₍₃₀₀₋₃₀₀₀₎ map of Quasi-Random (1) height typologies with individual floors

Table 4 - Quasi-Random (1) height typologies - UDI results



Random	Original Geometry	1_U Shape	2_Courtyard	3_Atrium & Courtyard	4_F shape	5_Perimeter
UDI 300-3000	14%	24%	24%	25%	24%	27%
UDI <300	82%	71%	71%	70%	71%	66%
UDI >3000	3%	5%	5%	5%	5%	7%

Table 5 - UDI (300 – 3000) percentage for Quasi-Random (1) height typologies.

Floor	1_U Shape	2_Courtyard	3_Atrium & Courtyard	4_F shape	5_Perimeter
1	12%	14%	13%	12%	9%
2	13%	14%	13%	13%	10%
3	13%	15%	14%	13%	10%
4	14%	15%	15%	14%	11%
5	15%	16%	16%	15%	12%
6	16%	17%	16%	16%	14%
7	17%	17%	17%	17%	15%
8	19%	18%	18%	17%	16%
9	20%	19%	19%	19%	18%
10	21%	20%	20%	20%	20%
11	22%	21%	22%	21%	22%
12	26%	23%	23%	23%	31%
13	28%	24%	24%	25%	32%
14	29%	25%	25%	26%	33%
15	31%	26%	27%	27%	35%
16	33%	27%	29%	28%	37%
17	36%	28%	32%	30%	39%
18	38%	29%	35%	32%	41%
19	39%	30%	39%	34%	44%
20	40%	32%	45%	36%	44%
21	46%	45%	45%	44%	55%
22	47%	47%	47%	45%	56%
23	49%	48%	49%	46%	57%
24	50%	48%	50%	47%	59%
25	52%	49%	51%	48%	60%

26	54%	51%	53%	50%	61%
27	57%	53%	57%	52%	62%

The first eleven floors in the in the quasi-random typology have the same floor footprint as all the uniform ones (Table 5). Therefore, a significant portion of the building is same between the uniform and quasi-random cases. Height variations in the towers cause the geometric variations in test cases, but they do make a small portion of the total building area.

Figure 56 demonstrates a visual image of a second quasi-random height configuration. While FAR and site coverage is the same amount in all cases, some cases have better performance in providing useful daylight levels inside the building. The highest $UDI_{(300-3000)}$ is 39% of the year in daylight hours.

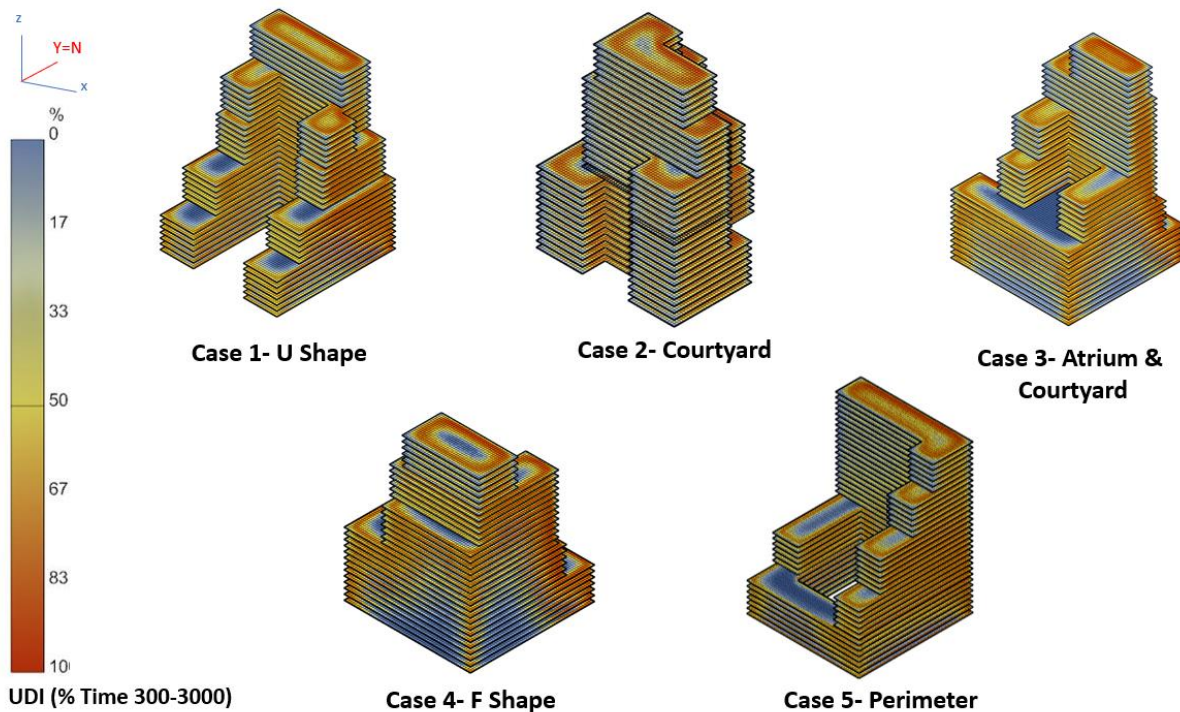
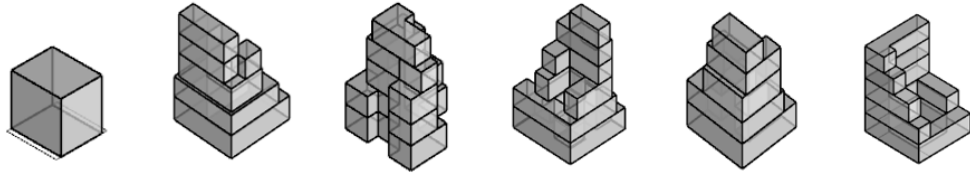

Figure 56 - $UDI_{(300-3000)}$ map for Quasi-Random (2) height typologies with individual floors

Table 6 - Quasi-Random (2) height typologies - UDI results



Random	Original Geometry	1_U Shape	2_Courtyard	3_Atrium & Courtyard	4_F shape	5_Perimeter
UDI 300-3000	14%	36%	35%	31%	29%	39%
UDI <300	82%	57%	59%	61%	65%	50%
UDI >3000	3%	7%	6%	8%	6%	11%

4.3 COMPARE ALL THE UNIFORM HEIGHT RESULTS WITH QUASI RANDOM HEIGHT

Comparison of the average UDI values for all the uniform height cases and random height cases are performed (Table 7) and the following conclusions are drawn:

Table 7 - The average UDI values for all the uniform and random height typologies

UDI Range	Original Geometry	1_U Shape		2_Courtyard		3_Atrium & Courtyard		4_F Shape		5_Perimeter	
		Uniform	Random	Uniform	Random	Uniform	Random	Uniform	Random	Uniform	Random
UDI 300-3000	14%	21%	36%	20%	35%	23%	31%	20%	29%	22%	39%
UDI <300	82%	74%	57%	75%	59%	72%	61%	76%	65%	73%	50%
UDI >3000	3%	5%	7%	5%	6%	5%	8%	6%	6%	4%	11%

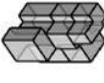
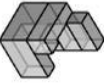

- The first case representing the base geometry (typical building footprint in Seattle) shows that daylight levels fall within the desired threshold 14% of the entire year; and in 82 % of the year, there is a need for electric lighting to meet the criteria.
- While Figure 56 reveals a positive relationship between variety in height configuration and overall useful daylight levels in different urban typologies, the differences are not significant. The building-scale analyses does not reveal whether daylight levels are over or lower the criteria at an individual floor level. In other words, the daylight distributions across the floors within each typology is not explicit. Figure 57 provides this information about the underlit and overlit percentages.

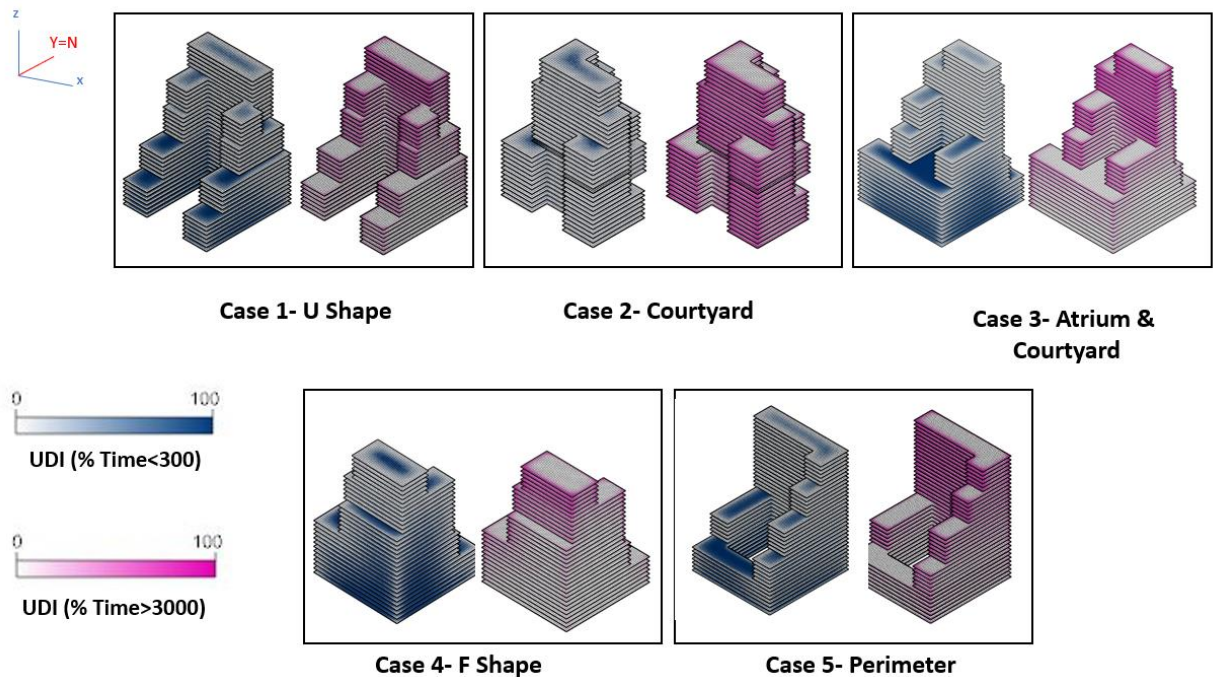

Figure 57 - Quasi-Random (2) height typologies with individual floors UDI underlit & overlit map

- As evident in Table 7, the main problem is the deficiency of daylight, mostly on lower floors.
- Among all cases, those with quasi-random height configuration have better performance in providing useful daylight levels in comparison with all the uniform ones. Randomness in height leads to have variety in massing distribution and therefore, it has a potential to improve the daylight levels.
- Among all the five typologies, the highest UDI is achieved by the perimeter shape (39%). It is an improvement, but it is not a satisfactory result.

4.4 SIMULATION FOR THE INFORMED DESIGN

Case 5 “Perimeter Shape” which has the best daylight performance is selected for the informed design phase. In this phase, instead of randomly locating the towers, the sky obstruction percentages around the block are used to determine the right location of towers. Lower sky percentages are desirable as under-lit interiors are identified as a major design issue (Figure 58).

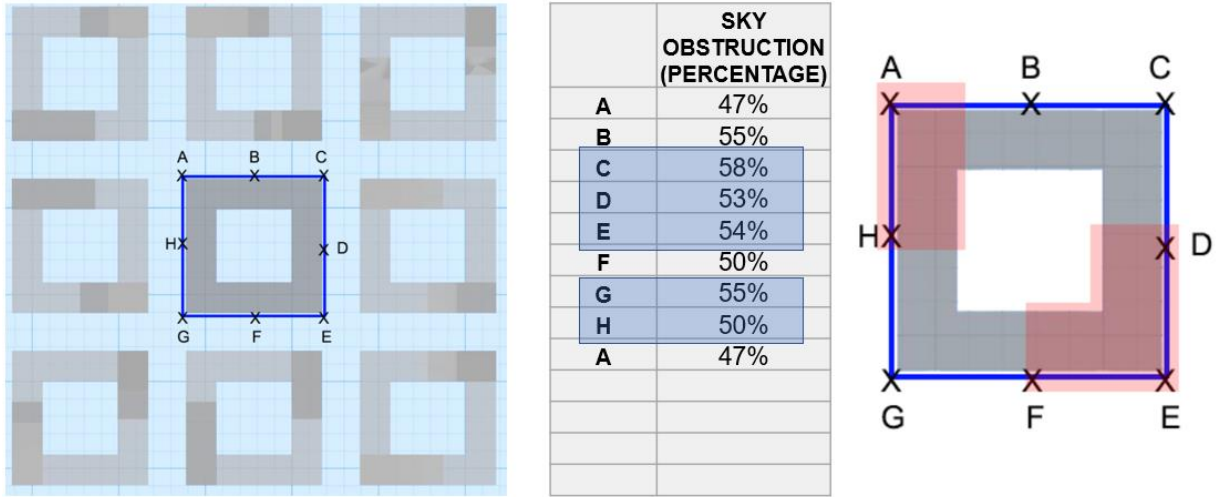

Figure 58 – Determining the towers' location based on SVF percentage around the block

Table 8 displays the sky obstruction percentages in different heights on the boundary of the studied block. Sky obstruction for the first four floors is almost 60% percent and therefore, there is not enough daylight penetration in this high-density zone. The simulations are performed above the fifth floor.

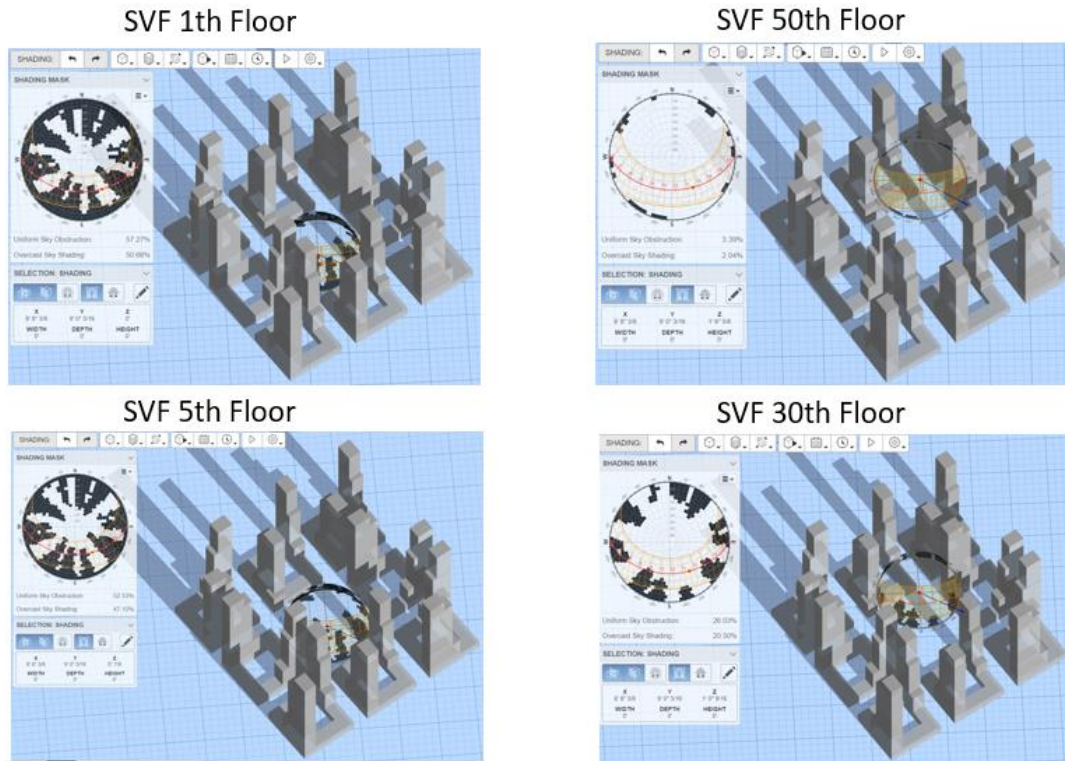

Figure 59 - Sky obstruction percentage in different heights on the boundary of the studied block

Table 8 - Sky obstruction percentage in different heights on the boundary of the studied block

Floor	Sky Obstruction (%)	Height
1	56%	0
5	50%	40 Ft
14	41%	130 Ft
30	26%	290 Ft
50	4%	490 Ft

4.4.1 Automated Shading Strategies

Figure 60 shows the simulation results for the informed design phase. The automated shading has been assigned for sixteen upper floors since the UDI-overlit is above 15 percent in these floors.

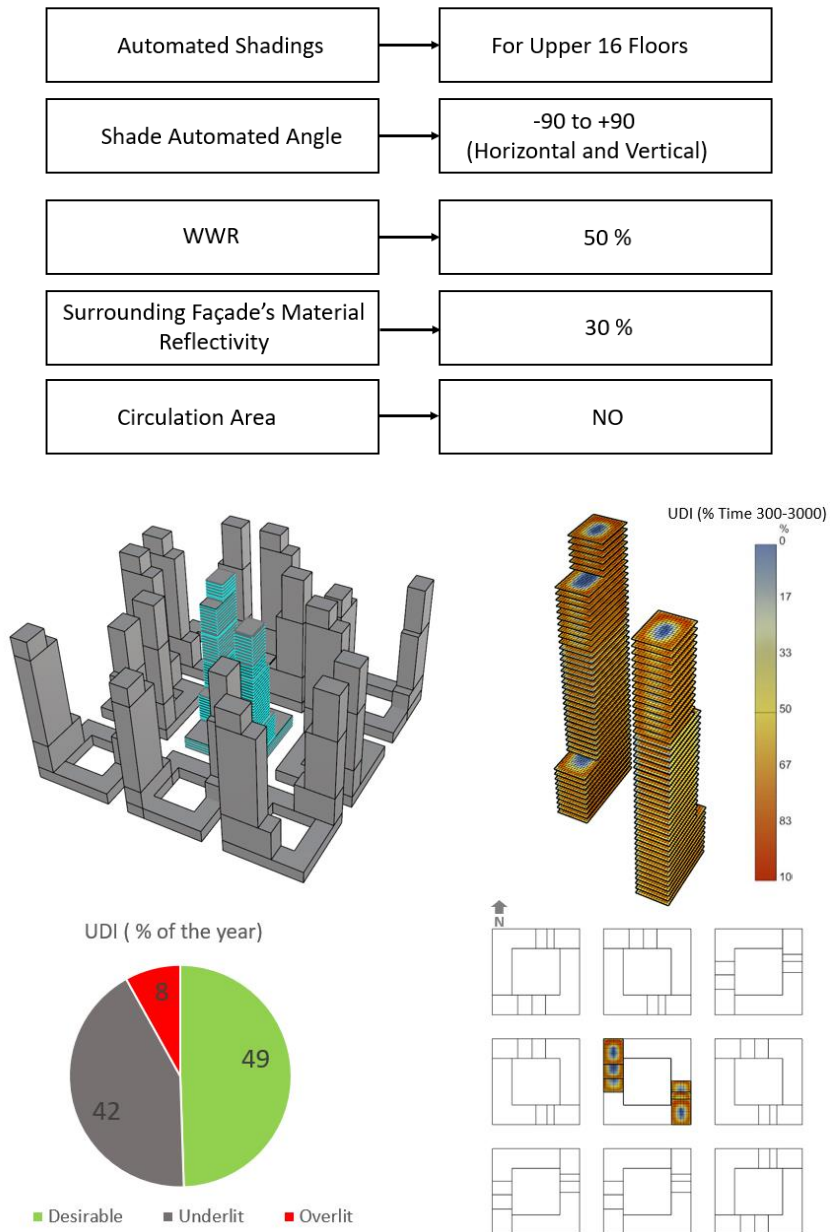

Figure 60 -Step 1- Simulation result for the informed design phase (studied parameter is **automated shadings**)

In the next step, shade automated angle is studied (Figure61). When the shade automated angle is between -45 to +45, the overall UDI is increased to 51%. Narrower field of views in sensors perform better for controlling shading devices.

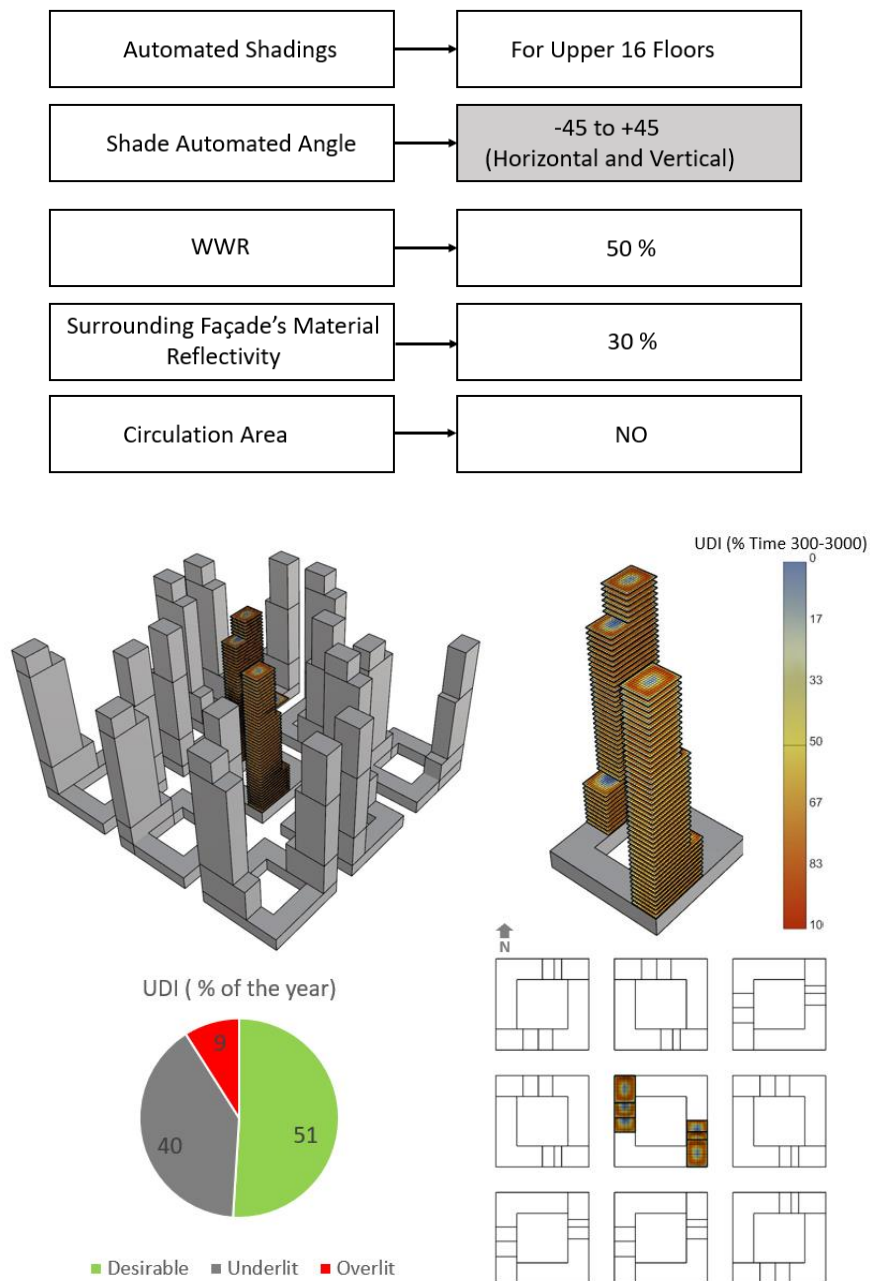

Figure 61 - Step 2- Simulation result for the informed design phase (changing parameter is **shaded automation angle**)

4.4.2 Window-to-Wall Ratio (WWR)

The next parameter that is studied is WWR. In this step, the WWR is increased (from 50%) up to 75% (Figure 62). The results show that the UDI increase to 56% since the higher WWR ratio can increase exposure to daylight.

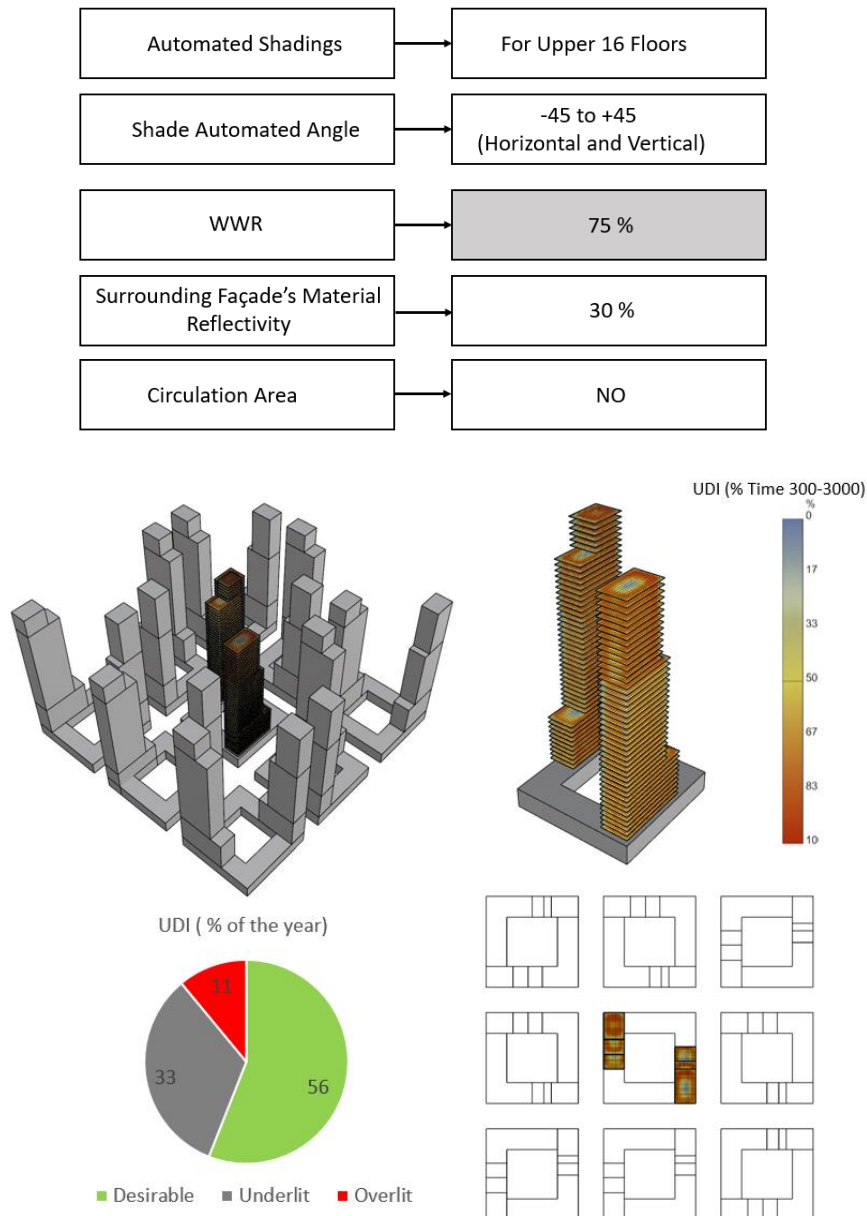

Figure 62 - Step 3- Simulation result for the informed design phase (changing parameter is window-to-wall ratio)

4.4.3 *Material Reflectivity*

Material reflectivity in neighboring structures is increased to 50% from 30%, and the UDI is increased to 58% (Figure 63). Table 9 displays that the UDI increase for the first 10 lower floors (5th to 15th) is more significant as these floors rely on reflections within the urban canyon more than upper floors that receive higher levels of direct light from the sky.

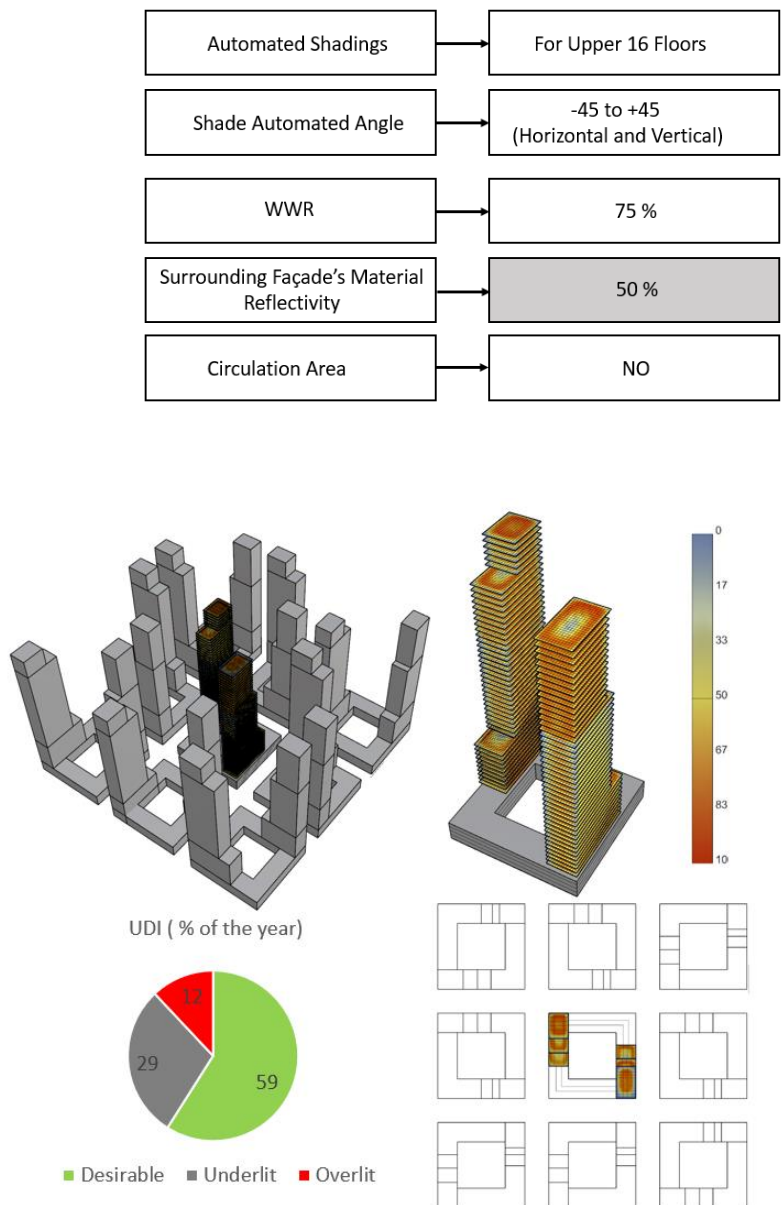

Figure 63 - Figure 58 - Step 4 - Simulation result for the informed design phase (changing parameter is material reflection)

Table 9 – Comparing UDI result for the first 10 lower floors

Floor	UDI (300-3000) neighbors' material reflection 30%	UDI (300-3000) neighbors' material reflection 50%
5	49%	52%
6	49%	52%
7	50%	52%
8	50%	53%
9	51%	53%
10	51%	53%
11	51%	53%
12	51%	54%
13	51%	54%
14	52%	54%
15	52%	55%

4.4.4 Circulation Area

The last step is to remove the circulation area from the grids. Based on the results in the previous section, one of the main problem in all the cases is that the middle parts of the floor plates tend to have less exposure to daylight (Figure 64). In a high-rise buildings, the center of the floor plate is usually utilized for elevators and circulation. A space-efficient building has an approximate core that is 30% of the total floor area. To reflect this, a core has been added to the last case, and the maximum depth from window to the core is limited to 20 feet. The result in figure 62 displays that UDI (300-3000) has reached to 66%.

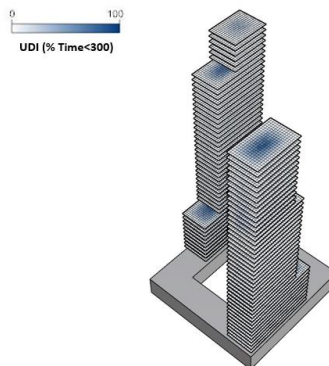

Figure 64 - The middle parts of the floor plates tend to have less exposure to daylight

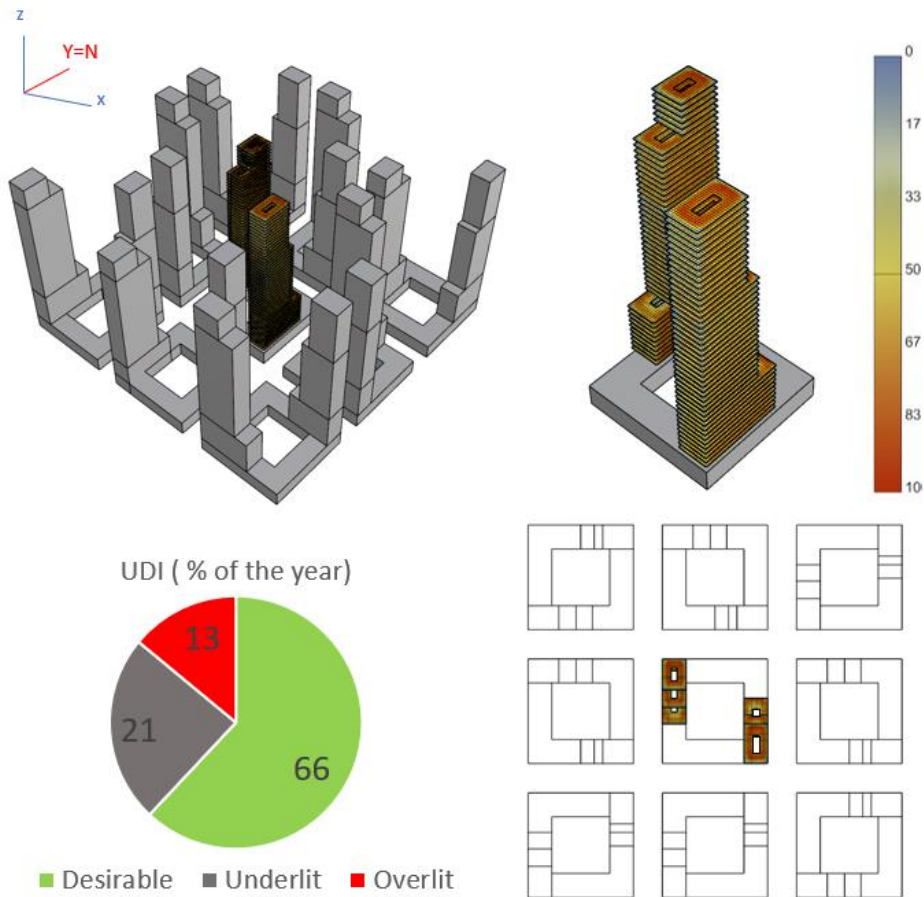
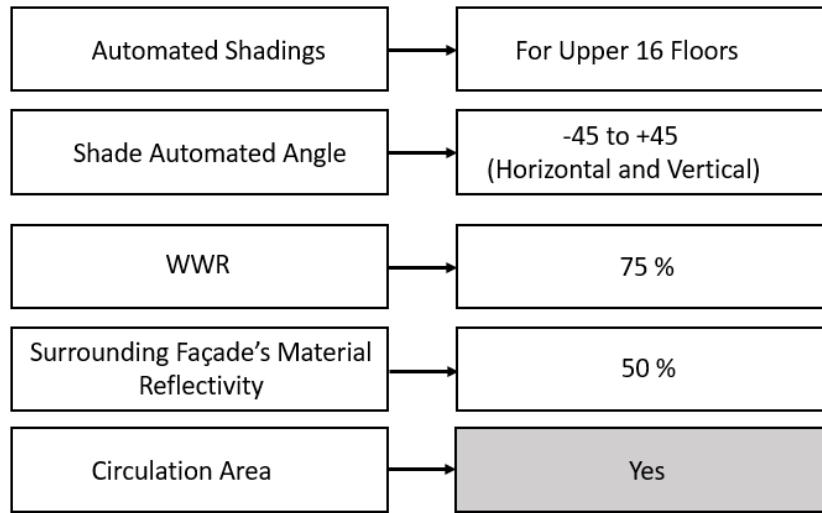

Figure 65 - Step 5 - Simulation result for the informed design phase (changing parameter is removing circulation area)

4.5 REMARKS:

The first case or the original geometry which is used in current urban zoning regulations and the final case which is the created to the proposed workflow are illustrated in Figure 66. In final case, daylight availability in building level and also at an urban- level is in a desired level for a whole year, the original geometry almost depends on electric light during the whole year.

Thus, the informed- design case is very Energy Efficient. It may have some added costs but buildings with daylight are more valuable. If energy improvements are considered as part of an overall process, the added costs are often balanced by long-term savings. The initial expenses continue to pay back over time, like a good investment. Building with daylight are much healthier and more productive places which is an important issue in office design. They have higher lease rates and decreased utility costs, and therefore they can perform better in market.

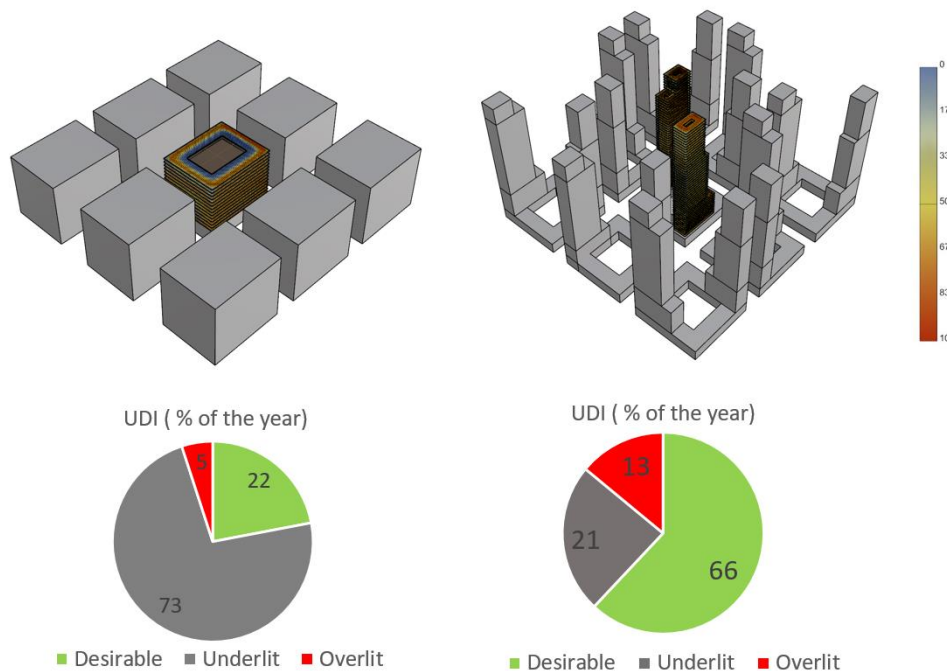

Figure 66 - Final comparison between the original geometry and the last studied case (the informed one)

Chapter 5. CONCLUSIONS

The primary goal of this thesis is to propose a simulation-based daylighting analysis procedure for neighborhoods that can bridge the gap between urban design level and individual building design level. The demonstrated method proposes a different expanding pattern and façade design that can secure access to daylight in urban layouts and buildings.

In chapter 2, background information on urban daylight and solar design strategies is discussed.

The existing daylighting studies on urban form and canyon are categorized as three groups: Solar Geometry, Solar Radiation, and Climate-based Daylight Availability. Each of these categories has shortcomings. The first group focuses on maximum access to the sunlight. The second group is a currently redundant approach for daylight simulations, as it was utilized when annual daylight simulation approaches were computationally prohibitive. The third group includes daylight availability studies that utilize climate based annual daylighting simulations in a given urban zone or block. However, the oversimplification of the data poses limitations, as discussed in Chapter 2. Chapter 3 addresses to a need for a refined workflow. Setting and the relevant parameters (materiality, shading strategies, and geometric distribution of urban canyon) and the evaluative criteria (UDI) are identified within the scope of this thesis. This simulation approach includes both the positive impacts of surrounding buildings (such as delivering reflected diffuse daylight and providing overshadowing that may negate aggressive shading controls on the façade) and the negative impacts (such as obstructing the sky and causing reflected glare).

Chapter 4 presents the simulation results. The results provide useful guidelines for planning high-density cities with adequate daylight levels:

1. Randomness in vertical layout could improve the daylight levels both at an urban street level and building floor-levels. However, daylight levels can be further improved with thoughtful design of vertical layouts with parameters such as orientation, shading devices, and material reflectivity.
2. This study shows that the following parameters improve access to daylight for the massing itself as well as for neighboring buildings:
 - Geometry
 - Material reflectance
 - Shading Automation settings
 - Window-Wall Ratio
 - Location of towers in the urban block, all together.
3. The refined workflow presented in this thesis, provides flexibility in the daylight criteria range with the presumption that “preventing all direct sunlight to interiors” is problematic and undesirable. Therefore, based on the functionality of space, the UDI criteria can be defined differently (through DIVA Grasshopper interface). Since the UDI upper threshold can be defined based on the functionality of space, automated shading devices can be operated at the building level to filter out sunlight above a given threshold and prevent glare based on the activity performed in a place (different activities or different adaptation levels may have different thresholds).

REFERENCES

- [1] "Radiance," Lawrence Berkeley National Lab (LBNL) – Berkeley, CA, 1984. [Online]. Available: <http://radiance-online.org/>. [Accessed 2019].
- [2] J. Alstan Jakubiec and C. F. Reinhart, "DIVA 2.0: INTEGRATING DAYLIGHT AND THERMAL SIMULATIONS USING RHINOCEROS 3D, DAYSIM AND ENERGYPLUS," in *Proceedings of Building Simulation*, Sydney, 2011.
- [3] T. Dogan, C. F. Reinhart and P. Michalatos, "Urban Daylight simulation: Calculating the daylit area of urban designs," in *Proceedings of SimBuild 2012*, Madison, Wisconsin, USA, 2012.
- [4] T. Dogan and Y. C. Park, "A critical review of daylighting metrics for residential architecture and a new metric for cold and temperate climates," *Lighting Research and Technology*, 2018.
- [5] J. Strømmand-Andersen and P. Sattrup, "The urban canyon and building energy use: Urban density versus daylight and passive solar gains," *Energy and Buildings*, pp. 2011-2020, 2011.
- [6] M. Lepore, "The right to the sun in the urban design," *International journal of Architecture Technology and Sustainability*, vol. 2, no. 1, pp. 25-43, 2017.
- [7] T. Garnier, *Une Cite Industrielle*, R. Mariani, Ed., Rizzoli , 1917.

- [8] D. Watson and L. Kenneth , *Climatic Building Design*, New York: McGraw-Hill Book Company, 1983.
- [9] R. L. Knowles, "The solar envelope: its meaning for energy and buildings," *Energy and Buildings*, no. 35, pp. 15-25, 2003.
- [10] R. Knowles, *Sun, Rhythm and Form*, Massachusetts: The MIT Press, 1981.
- [11] R. Knowles , *Ritual House - Drawing on Nature's Rhythms for Architecture and Urban Design*, Washington DC: Island Press, 2006.
- [12] W. H. Whyte, *City: Rediscovering the Center*, Philadelphia: University of Pensilvania Press, 1988.
- [13] "Protecting Solar Access," SF Environment, A department of the City and County of San Francisco, San Fransisco, 2012.
- [14] "Norway Powered by Nature," April 2018. [Online]. Available: <https://www.visitnorway.com/listings/the-giant-sun-mirrors-in-rjukan/3632/>. [Accessed February 2019].
- [15] A. Bouchair, H. Tebbouche, A. Hammouni, M. Lehtihet and M. Blibli, "Compact cities as a response to the challenging local environmental constraints in hot arid lands of Algeria," *Energy Procedia*, no. 42, p. 493 – 502, 2013.
- [16] M. Sharma , "Orientation of buildings," *Building Digest*, no. 74, 1969.
- [17] B. Anderson, *Solar Energy Fundamentals in Building Design–Total Environment*, New York: McGraw-Hill Book Co., 1977.
- [18] K. Megson, "CLAD news for architects, designers, investors & developers," 24 July 2017. [Online]. Available: http://www.cladglobal.com/CLADnews/architecture_design/Sunlight-

architecture-design-urban-planning-Toronto-Vancouver-Paul-Kulig-right-to-light-Perkins--Will/333108?source=search. [Accessed 2018].

[19] "Lower Yonge Urban Design Principles + Recommendations," Perkins+Will, 20. [Online].

Available: <https://perkinswill.com/work/lower-yonge-urban-design-principles-recommendations>. [Accessed 2018].

[20] D. Howarth, "Dezeen Magazine," 27 February 2017. [Online]. Available:

<https://www.dezeen.com/2017/02/27/studio-gang-reveals-high-line-hugging-solar-carve-tower-40-tenth-avenue-new-york/>.

[21] R. Compagnon, "Solar and daylight availability in the urban fabric," *Energy and Buildings*, vol. 36, pp. 321-328, 2004.

[22] C. Polo López, M. Sala, L. C. Tagliabue, F. Frontini and S. Bouziri, "Solar radiation and daylighting assessment using the Sky-View Factor (SVF) analysis as method to evaluate urban planning densification policies impacts," *Energy Procedia*, vol. 91, pp. 989-996, 2016.

[23] M. van Escha, R. Looman and G. d. Bruin-Hordijk, "The effects of urban and building design parameters on solar access to the urban canyon and the potential for direct passive solar heating strategies," *Energy and Buildings*, no. 47, pp. 189-200, 2012.

[24] E. Saratsis, T. Dogan and C. F. Reihart, "Simulation-based daylighting analysis procedure for developing urban zoning rules," *Building Research & Information*, vol. 45, no. 5, pp. 478-491, 2017.

- [25] V. Cheng, K. Steemers, M. Montavon and R. Compagnon, "Urban Form, Density and Solar Potential," in *International Conference on Passive and Low Energy Architecture*, Geneva, 2006.
- [26] D. Steyn, "The calculation of view factors from fisheye-lens photographs: Research note," *Atmosphere-Ocean*, vol. 18, no. 3, pp. 254-258, 1980.
- [27] A. Marsh, "andrewmarsh.com," [Online]. Available: <http://andrewmarsh.com/software/>. [Accessed 2018].
- [28] K. Kensek and J. Yong Suk, "Difference between Daylight Factor (overcast sky) and Daylight Availability (clear sky) in Computer-based Daylighting Simulations," <https://www.academia.edu>, 2011.
- [29] R. Perez, R. Seals, J. Michalsky and R. Steward, "Modelling daylight availability and irradiance components from direct and global irradiance," *Solar Energy*, vol. 44, no. 5, pp. 271-289, 1990.
- [30] C. Reinhart, J. Mardaljevic and Z. Rogers, "Dynamic Daylight Performance Metrics for Sustainable Building Design," *Leukos*, vol. 3, no. 1, pp. 7-31, 2006.
- [31] N. Peterson, *The Space Between Research and Practice: A Critical Evaluation of Computer-Based Lighting Metrics*, Seattle: University of Washington, 2015.
- [32] J. Niemasz, "Diva for Rhino," 2018. [Online]. Available: <http://diva4rhino.com/user-guide/simulation-types/climate-based>. [Accessed 6 May 2018].
- [33] I. E. S. o. N. America, IESNA Lighting Handbook, 9th ed., M. S. Rea, Ed., 2000.

- [34] Z. Rogers and D. Goldman, "Daylighting Metric Development Using Daylight Autonomy Calculations In the Sensor Placement Optimization Tool," Architectural Energy Corporation, Boulder, 2006.
- [35] A. Nabil and J. Mardaljevic, "Useful daylight illuminance: a new paradigm for assessing daylight in buildings," *Lighting Research and Technology*, vol. 37, no. 1, pp. 41-59, 2005.
- [36] M. Beatriz Piderit Moreno and C. Yañez Labarca, "Methodology for Assessing Daylighting Design Strategies in Classroom with a Climate-Based Method," *Sustainability*, vol. 7, pp. 880- 897, 2015.
- [37] IES Spatial Daylight Autonomy (sDA) and Annual Sunlight Exposure (ASE), New York: Illuminating Engineering Society, 2013.
- [38] T. Dogan and Y. C. Park, "A critical review of daylighting metrics for residential architecture and a new metric for cold and temperate climates," *Lighting Research and Technology*, 2018.
- [39] "Seattle 2035, Development Capacity Report," Development Capacity Report, Seattle, 2014.
- [40] "Seattle 2035: Your city, Your future," 2014.
- [41] Y. Matrix, "www.infogram.com," [Online]. Available: <https://infogram.com/top-40-markets-for-office-deliveries-in-2019-v2-1h0n25prk93z6pe>. [Accessed 5 7 2019].
- [42] *City Of Seattle : Analysis And Decision Of The Director Of The Department Of Planning And Development*, Seattle: City of Seattle Office of Planning and Community Development.

- [43] G. Ward, "Radsite: radiance-online.org," [Online]. Available: <https://www.radiance-online.org/>. [Accessed 17 5 2019].
- [44] J. Alstan Jakubiec and C. F. Reinhart, "Overview and Introduction to DAYSIM and Current Research Developments," [Online]. Available: https://www.radiance-online.org/community/workshops/2012-copenhagen/Day1/Jakubiec/jakubiec,reinhart_radiance-workshop-presentation_daysim.pdf. [Accessed 17 5 2019].
- [45] D. B. Crawley, L. K. Lawrie and F. C. Winkelmann, "Software Tools for Building Envelopes: EnergyPlus: New, Capable and Linked," 2001.
- [46] S. Holl, Pamphlet Architecture #5: The alphabetical city, New York, 1980.
- [47] "CMS WillowBrook Construction Management," [Online]. Available: <http://www.cmswillowbrook.com/constructorknowledge/2015/2/27/architectural-terms-spandrel-more-than-just-spandrel-glass>. [Accessed 12 4 2019].
- [48] H. Gregory , "design-milk," 16 1 17. [Online]. Available: <https://design-milk.com/window-rollershade-simulated-sunlight/>. [Accessed 19 4 19].
- [49] A. Taylor, "The Atlantic," 22 October 2013. [Online]. Available: <https://www.theatlantic.com/photo/2013/10/using-giant-mirrors-to-light-up-dark-valleys/100613/>. [Accessed 26 February 2019].

