

LIQUIDATED URBANISM:
Found Condition and Exploited Conflict

Philip J. Syvertsen

A thesis submitted in partial fulfillment
of the requirements for the degrees of :
Master of Architecture +
Master of Landscape Architecture

University of Washington
2014

Committee:
Gundula Proksch, Co-Chair
Ken Yocom, Co-Chair

Program Authorized to offer degree:
Architecture + Landscape Architecture

© Copyright 2014
Philip Syvertsen

University of Washington

Abstract

Liquidated Urbanism:
Found Condition and Exploited Conflict

Philip J. Syvertsen

Co-Chairs of the Supervisory Committee:
Gundula Proksch, Department of Architecture
Ken Yocom, Department of Landscape Architecture

This thesis hypothesizes that large-scale commercial sites throughout the world are well-positioned to be assets for cities and communities in the future. The condition of a large-scale commercial space standing where a river once ran - found while studying in Oslo, Norway - was the seed for this thesis. I extrapolated from this found condition to propose diagrams for how urban rivers develop over time. Upon returning to Seattle, I sought and found a like condition: the Black River in Renton, WA. The Black River disappeared in 1916 after it was cut off from its source, Lake Washington, due to the Montlake Cut. Thereafter, industry and commercial spaces began to pave over the riverbed. Today, there is a 170,000 sf Fred Meyer that stands where the Black River ran. I believe that the key to re-orienting such sites is consideration of the land the big box structure occupies. The history of the Fred Meyer is inextricably tangled with the Black River and the infrastructure that has come to cross the site. Over time, the site could be read as a series of transgressions against the river. This thesis deploys a similar process of transgression against the territory of the big box to alter the site's trajectory. Initial transgressions in the language of the landscape ultimately inform more than just the exterior surface. The architecture adopts but also withstands the landscape and its shifting hydrology, creating new program and inviting new users in the process.

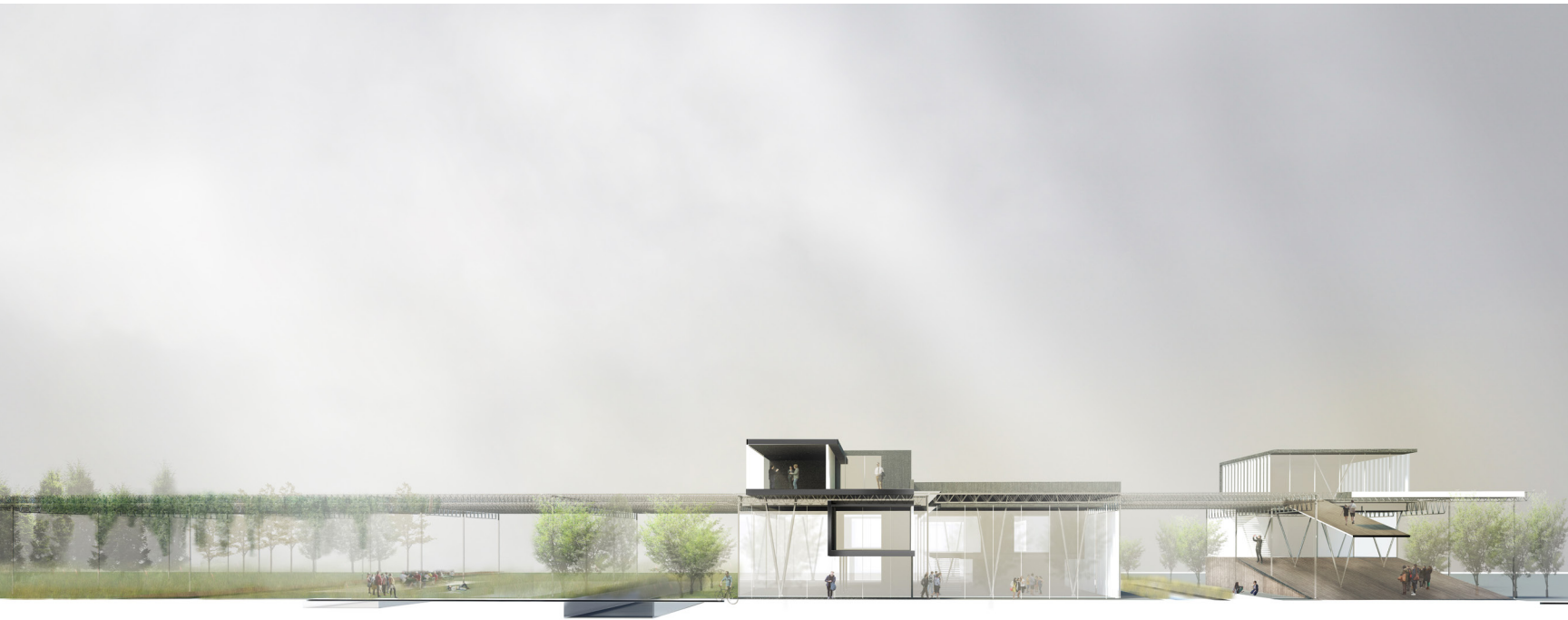

TABLE OF CONTENTS

Acknowledgements	6
List of Figures	7
Introduction	9
Chapter 1 Urban Rivers	11
Chapter 2 Black River	15
Chapter 3 Theoretical Framework	22
Chapter 4 Design Approach + Design	28
Chapter 5 Reflections	56
Bibliography	58
Figure Credits	59
Appendix	60

ABSTRACT

This thesis hypothesizes that large-scale commercial sites throughout the world are well-positioned to be assets for cities and communities in the future. The condition of a large-scale commercial space standing where a river once ran - found while studying in Oslo, Norway - was the seed for this thesis. I extrapolated from this found condition to propose diagrams for how urban rivers develop over time. Upon returning to Seattle, I sought and found a like condition: the Black River in Renton, WA. The Black River disappeared in 1916 after it was cut off from its source, Lake Washington, due to the Montlake Cut. Thereafter, industry and commercial spaces began to pave over the riverbed. Today, there is a 170,000 sf Fred Meyer that stands where the Black River ran. I believe that the key to re-orienting such sites is consideration of the land the big box structure occupies. The history of the Fred Meyer is inextricably tangled with the Black River and the infrastructure that has come to cross the site. Over time, the site could be read as a series of transgressions against the river. This thesis deploys a similar process of transgression against the territory of the big box to alter the site's trajectory. Initial transgressions in the language of the landscape ultimately inform more than just the exterior surface. The architecture adopts but also withstands the landscape and its shifting hydrology, creating new program and inviting new users in the process.

ACKNOWLEDGEMENTS

I am deeply grateful to have had such wonderful support throughout my time at UW and would like to thank a number of people who have been especially generous:

My family, Syvertsens in Seattle and Chicago, for not only bearing with me through graduate school but for being entirely interested on top of that.

Page, for all of your love and support these three past years.

The CBE faculty, especially my advisers, Ken Yocom and Gundula Proksch, for your smart, critical feedback and for your words of encouragement throughout thesis. And Daniel Friedman for challenging, advising, and working with me throughout my time at UW. I am deeply appreciative of all of the faculty with whom I had the opportunity to work.

The Valle Scholarship for providing me the opportunity of a lifetime, traveling and studying in Norway for the summer of 2013. The relationships I made and the work I began will continue to permeate who I am.

The administration of both the landscape and architecture schools have gone above and beyond expectations in order to figure out how to make an architecture + landscape architecture dual degree work - thank you.

Finally, my architecture and landscape architecture friends and classmates at UW and beyond for always lending a hand or an ear and constantly raising the bar.

LIST OF FIGURES

- Figure A Downspouts and 'cuts' in the landscape in Oslo, Norway
- Figure B The Høvinbekken River in Oslo
- Figure 1.1 Urban river succession diagrams
- Figure 1.2 Sketches based on the work of G.E. Petts
- Figure 2.1 Puget Sound hydrology
- Figure 2.2 1940 aerial map showing dry Black River
- Figure 2.3 Black River Profile
- Figure 2.4 Flooded street in Renton, 1926
- Figure 2.5 Puget Sound hydrology map including Howard Hanson Dam
- Figure 2.6 Development on the Black River
- Figure 4.1 Renton Shopping Center site succession diagrams
- Figure 4.2 Public Open Space
- Figure 4.3 Zoning
- Figure 4.4 Impervious pavement where the Black River ran
- Figure 4.5 Existing site
- Figure 4.6 Existing organizational grid of the site
- Figure 4.7 Map of conveyances on site
- Figure 4.8 Existing condition
- Figure 4.9 First "cuts"
- Figure 4.10 Next "cuts"
- Figure 4.11 Shopping inventions
- Figure 4.12 Big box downsize
- Figure 4.13 River emerges in flood conditions
- Figure 4.14 First Phase proposed plan
- Figure 4.15 Hop garden perspective
- Figure 4.16 Landscape Architecture diagrams
- Figure 4.17 Architecture diagrams
- Figure 4.18 Proposed ground floor plan
- Figure 4.19 Building section

- Figure 4.20 Building section
- Figure 4.21 Section perspective
- Figure 4.22 Hardie Avenue / Black River perspective
- Figure 4.23 Cafe perspective
- Figure 4.24 Black River Passage perspective
- Figure 4.25 Proposed site plan
- Figure 5.1 Existing site organization

Figure A Downspouts and “cuts” in Oslo, Norway



INTRODUCTION

This thesis began in the summer of 2013 when I had the opportunity to study in Oslo, Norway, thanks to the University of Washington Valle Scholarship. The work I did that summer produced two fascinations: one at the scale of a sidewalk and the other at the scale of a city. The first fascination had simply to do with the means by which stormwater moved from building, to sidewalk, to street. Due to the depth of permafrost in Oslo, it is most efficient to convey water above ground as opposed to digging below permafrost each time there is a need for pipe. The result is “cuts” in the sidewalk as seen in figure A.

The second fascination is the result of an opportunity I had to work with AHO Landscape Architecture Professor Kelly Shannon. AHO is Oslo’s architecture and landscape architecture school and Professor Shannon has spent a lot of her time there studying Oslo’s rivers. Along with another student at AHO I worked on one such river, the Høvinbekken. Like

many of Oslo’s rivers, the Høvinbekken is primarily piped. On its way from the forest north of Oslo to Oslofjord, the Høvinbekken runs directly beneath a high-rise mall in the Oslo neighborhood of Økern (see figure B). Working on this project I became interested in the condition at hand: mall on top of river. The juxtaposition of forces, capital on top of nature, interests me in part because I believe it immediately implicates the two disciplines I am studying, architecture and landscape architecture.

The condition of a large commercial space standing above a river was the seed for this thesis. In the pages that follow, I will discuss four topics that grew out of the research I did in Oslo: urban rivers, generally and a specific case; the position of this thesis in a theoretical and professional framework; the design approach and design for the site; and finally, reflections on an architecture + landscape architecture thesis.

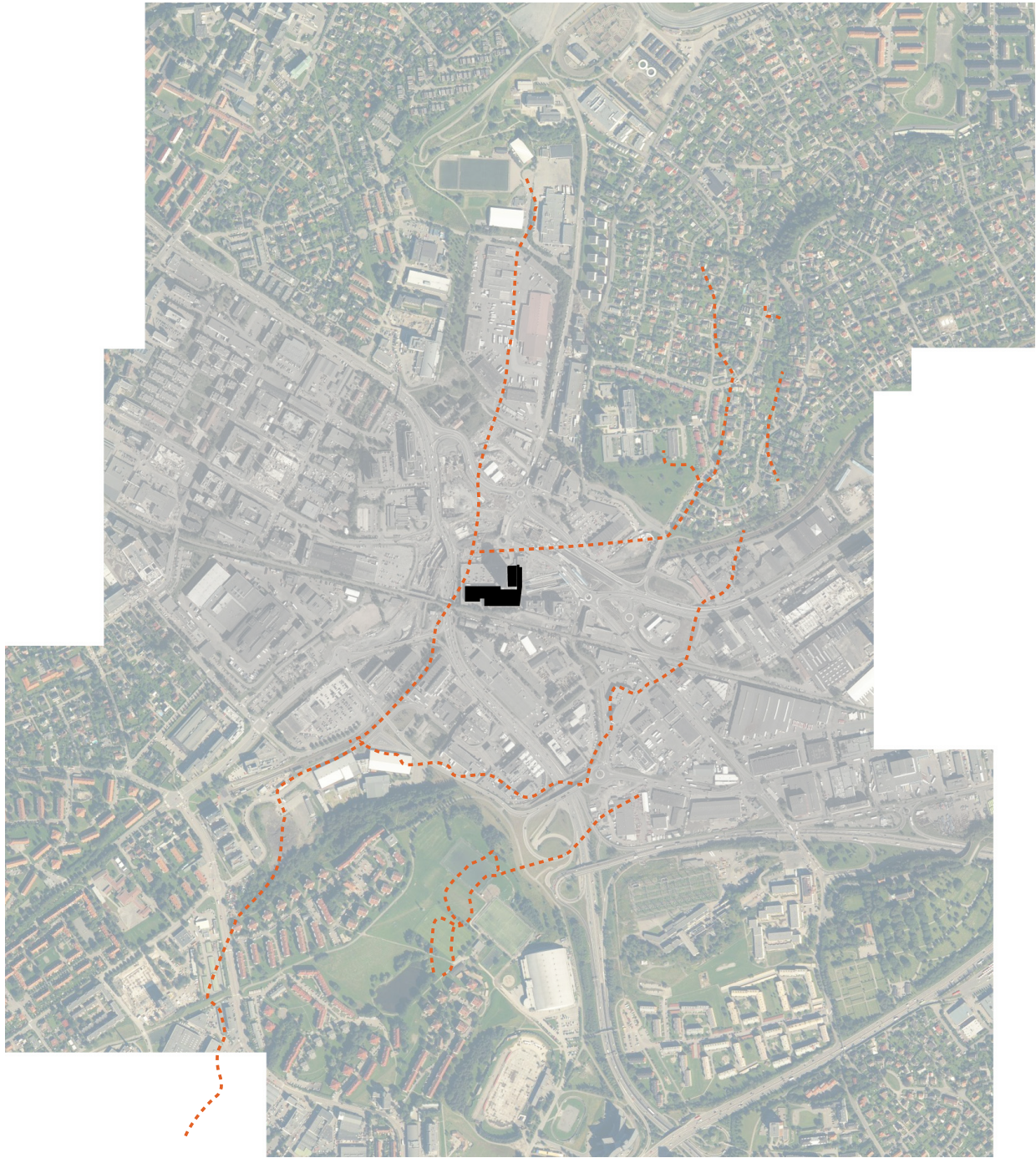

Piped Høvinbekken
.....

Figure B The Høvinbekken River in Oslo runs beneath a high-rise mall, rail, and highways before entering Oslofjord

CHAPTER 1: Urban Rivers

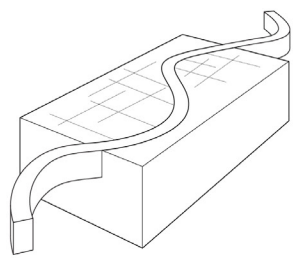

Agriculture

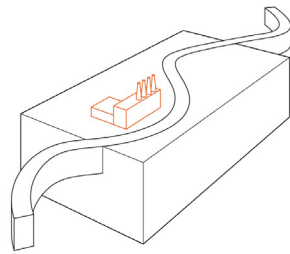

Industry

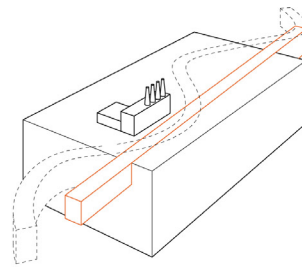

Channelization

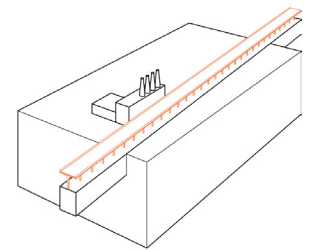

Infrastructure

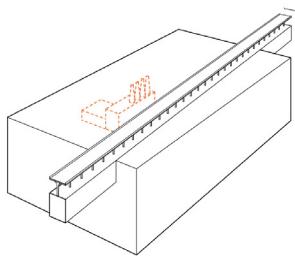

Deindustrialization

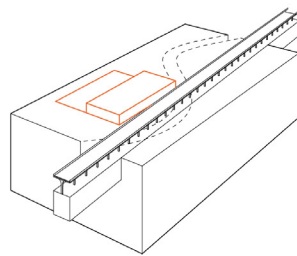

Commerical

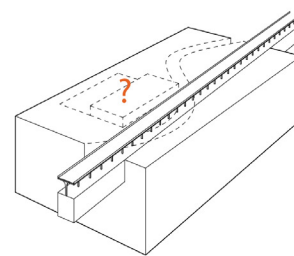

Next

Figure 1.1 Urban river succession diagrams

Figure 1.2 Sketches based on the research of G.E. Petts in relationship to forested riparian corridors.

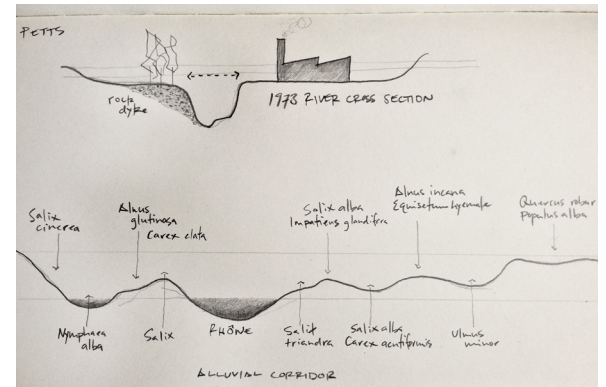
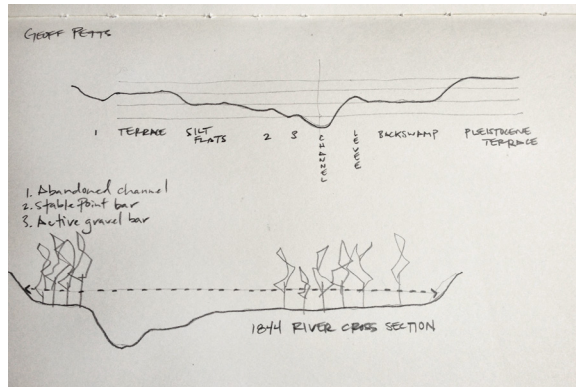

I suspected that the condition, mall on top of river, was not unique to Økern and so I began research, working backwards from the found condition. Drawing from the work of G. E. Petts, among others, I developed a hypothesis for the succession pattern of an urban river. Riparian river corridors were once characterized by broad, seasonally inundated floodplain ecotones up to 10 km wide¹. While these riparian corridors carved low-lying terrain, they were far from flat. The sketches in figure 1.2, adapted from Petts, describe the evolution of forested riparian corridors where once-braided rivers are reduced to a single, straight channel. The past 200 years however have seen rivers throughout Europe and America change from meandering and varied to a single, straight channel with narrow riparian zones.² Part of the reason for the immense manipulation of rivers over time is the development of infrastructure. The era of the mega infrastructure project opened in the second half of the 19th Century, and the desire to control water was foremost.³

Controlling water was critical because it meant access to water for drinking and irrigation; potential for hydro-power; and potential for transportation. By 1971, constructed reservoirs and dams had inundated an area in excess of 190 million acres.⁴ The acts of damming certain areas and draining others were part of a process of producing flat and dry space on which the straight lines of the railway and the rectilinear grid of streets and the lots of a town could be laid out.⁵ The act of mapping and filling or draining lowland, saturated spaces effectively reduced the earth's depth to a surface.⁶ This was all part of a process which Alfred Crosby referred to as ecological imperialism.⁷ Wherever and whenever an ecosystem stood in the way of development, the interests of capitalism took control.

Water was central to the mega-project movement of the late 19th Century and rivers played a role as key pieces of infrastructure. Since then, development patterns show that

over time infrastructure does not relocate but entrenches in the space it already occupies.⁸ As a result, the first phase of infrastructure development and its reliance on rivers predicted the development of future infrastructure.

The urban river succession diagrams I have developed (figure 1.1) begin with the river already a piece of infrastructure – used for irrigation. Subsequent to the mega-projects of the late 19th Century, which controlled flooding in typically inundated floodplains, industry moved to riverbanks, leveraging access to hydropower as well as waterborne transportation. To better suit the needs of industry, many rivers became channelized. Not long after channelization, automotive transportation became predominant and road networks supplanted waterborne transportation as the critical local and regional network. Currently, many cities are in a process of deindustrialization. Most immediately in the place of industry, larger commercial outlets

have moved in. What happens next is what this thesis openly asks.

The typology of the big box store is a product of how sites and cities have developed over time. This thesis proposes that the same processes that introduced big box can be leveraged to dismantle it and regenerate the space it occupies. Large-scale commercial outlets, sited according to the urban river succession diagram I propose, are critical parts of how fringe cities can develop. Big box sites occupy and cap potentially rich ecological resources; recovering those resources can re-code cities, once an ideal home for Wal-Mart, to once again sustain themselves

The urban river succession diagram represents the condition I wanted to explore with this thesis. While I studied one such condition in Oslo, I sought another upon my return to Seattle. My method for finding such a condition was simple: search for big box retailers in the Seattle area. It was not long before I found a

170,000 square foot Fred Meyer Supercenter
sited in the riverbed of what was the
Black River.

Endnotes

1. Petts, Geoffrey. (1990). "Forested River Corridors: A Lost Resource," in Denis Cosgrove and Geoffrey Petts (eds.) *Water, Engineering and Landscape*; New Delhi: CBS Publishers & Distributors, 12.
2. Ibid, 12.
3. Petts, Geoffrey. (1990). "Water, engineering and landscape: development, protection and restoration," in Denis Cosgrove and Geoffrey Petts (eds.) *Water, Engineering and Landscape*; New Delhi: CBS Publishers & Distributors, 203.
4. Ibid, 189.
5. Giblett, Rodney J. (1996). *Postmodern Wetlands Culture, History, Ecology*. Edinburgh: Edinburgh UP, 74.
6. Ibid, 74
7. Ibid, 74
8. Varnelis, Kazys. (2005). "Centripetal City," *Cabinet Magazine*, Issue 17. <http://www.cabinetmagazine.org/issues/17/varnelis.php>

Chapter 2:
Black River,
Renton, WA

*That was quite a day for the white people at least. The waters just went down, down, until our landing and canoes stood dry and there was no Black River at all.*¹

- Joseph Moses, Duwamish Tribe

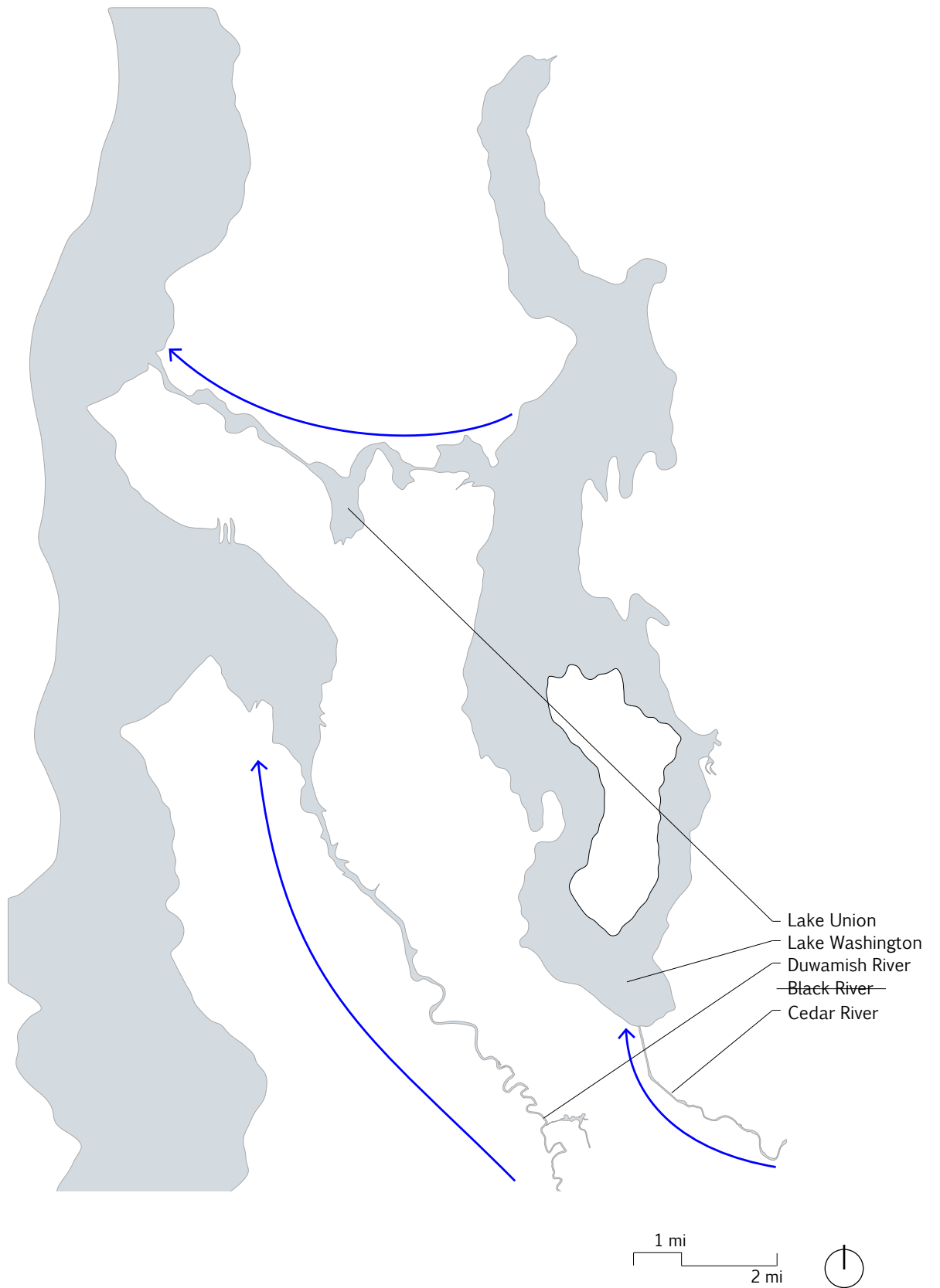

Figure 2.1 After the completion of the Montlake Cut in 1916, Lake Washington receded 8.8 feet, cutting off the Black River from its source.

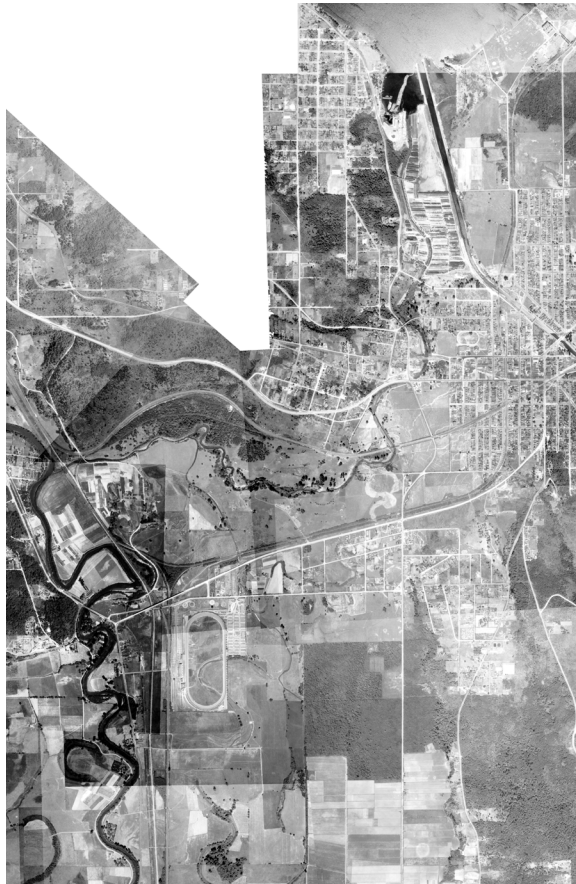

Figure 2.2 1940 aerial map showing the dry Black River

The American city has been shaped by the colliding forces of capitalism and nature.² Perhaps nowhere is that more true than the site of a particular Fred Meyer in Renton, Washington. On this site a 170,000 square foot Fred Meyer sits in the riverbed of what was the Black River. The process by which the Fred Meyer came to be parallels my hypothesis for how riparian corridors develop over time. Before delving further into the specific site of Fred Meyer, it is necessary to understand the history of the Black River. For some 5,000 years, until 1916, the Black River was a vital connection from Lake Washington and the Cedar River to the Green River.³ During that time, it was one of the most important waterways in the Puget Sound

region, important to the native people that lived alongside it and to the early settlers that turned it into an important artery.⁴ The Duwamish River began at the confluence of the Green River and the Black River, and carried water from Lake Washington and the Cedar River to the Puget Sound over the course of many years due to the very shallow grade change (see figure 2.3). When the river ran, prior to 1916, it flooded annually in the spring and the flood conditions remained for a month longer than nearby rivers because its floodplain was so flat.⁵ The flat, marshy land that surrounded the Black River was life-giving for the Duwamish people for at least 1,500 years.⁶

BLACK RIVER PROFILE

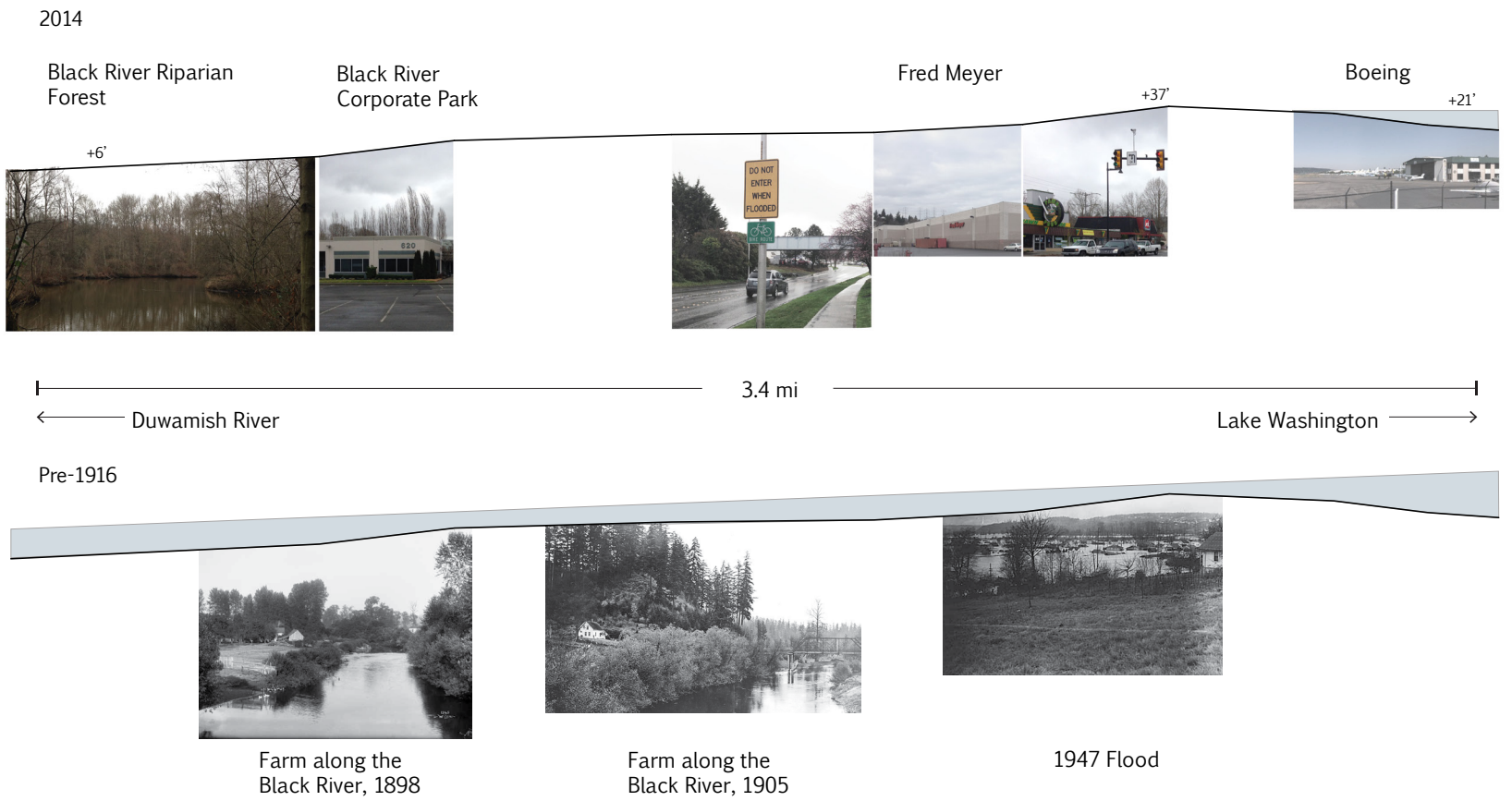

Figure 2.3 The shallow grade of the Black River has undergone massive changes since it was disconnected from Lake Washington.

Figure 2.4 Flooded streets in Renton, 1926



That was before 1916, which marks the year of completion for the Montlake Cut.⁷ The Montlake Cut served to connect Lake Washington more directly to Puget Sound. In the process, Lake Washington receded 8.8 feet and joined Lake Union, cutting off the Black River from its source (see figure 2.1).⁸ The words of Joseph Moses of the Duwamish Tribe describe the day that Lake Washington sank below the mouth of the Black River.

In the years following the Montlake Cut, the Black River was dry but discernible (see figure 2.2). The flat land around the river was primarily used for agricultural purposes despite the annual, major flood events. Flooding was in fact a big problem (see figure 2.4). In a sixty year period beginning in 1900, more than 30 major floods were recorded in the lowland region of the Green and Black Rivers.⁹ The floods were enough to keep industry and manufacturing interests out of the area, with the exception of Boeing which constructed

a plant on the shore of Lake Washington. Decades of demand to control the flooding finally resulted in the construction and opening of Howard A. Hanson Dam in 1962 (see figure 2.5).

Rather than controlling floods for the sake of agriculture, the construction of the dam cleared the way for industry to supplant farmland. Figure 2.6 illustrates the infill development of the riverbed since the construction of the dam. Prior to 1962 there was very little of what is there today – industrial warehouses, auto dealerships, office parks, and large-scale commercial centers (Wal-Mart, Safeway, Fred Meyer, etc). The site for this thesis is one of these developments, Renton Shopping Center, constructed in 1964. Before examining Renton Shopping Center in earnest, I will first describe the theoretical framework for this thesis.

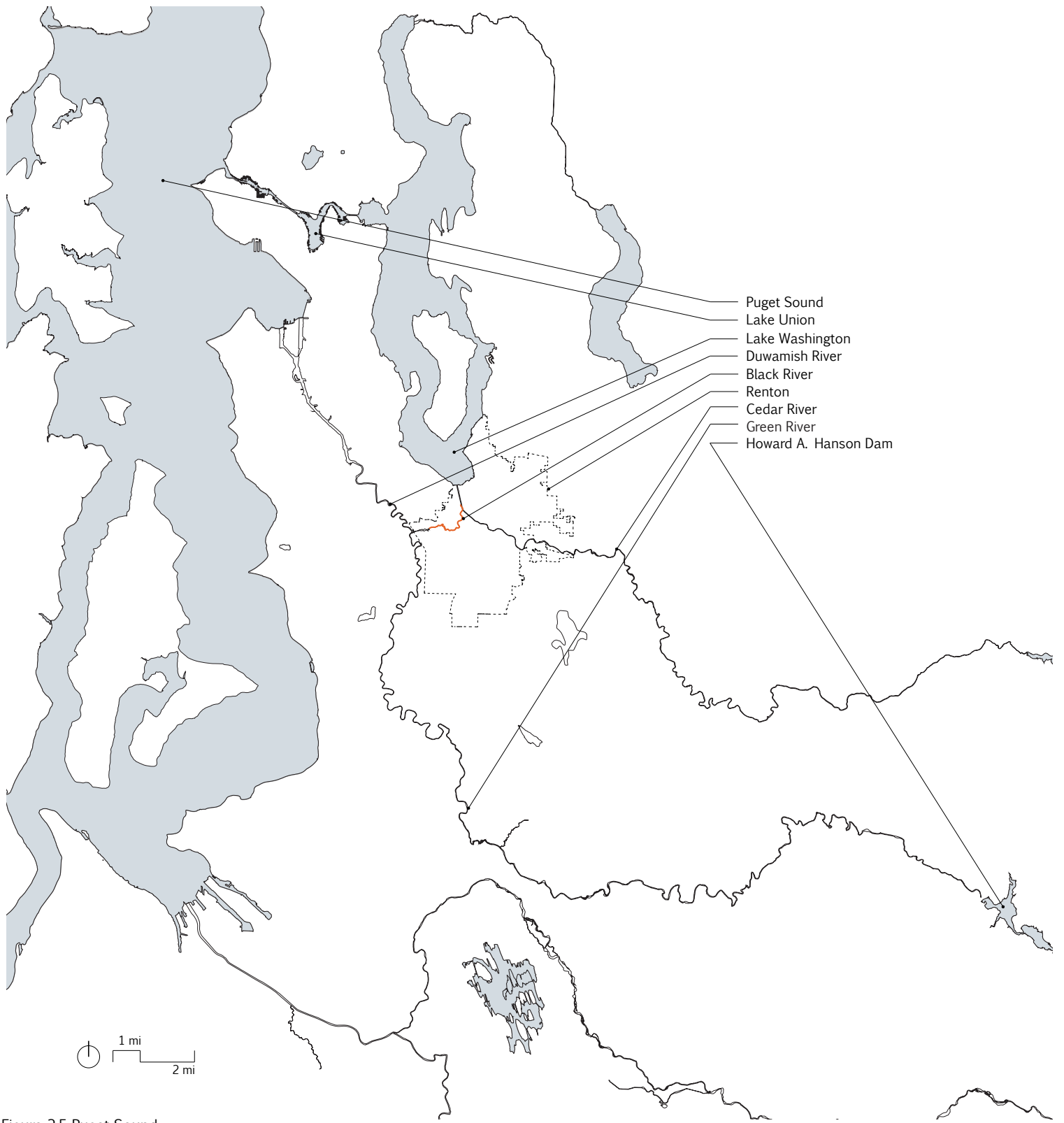

Figure 2.5 Puget Sound hydrology map, including the Howard Hanson Dam constructed in 1962

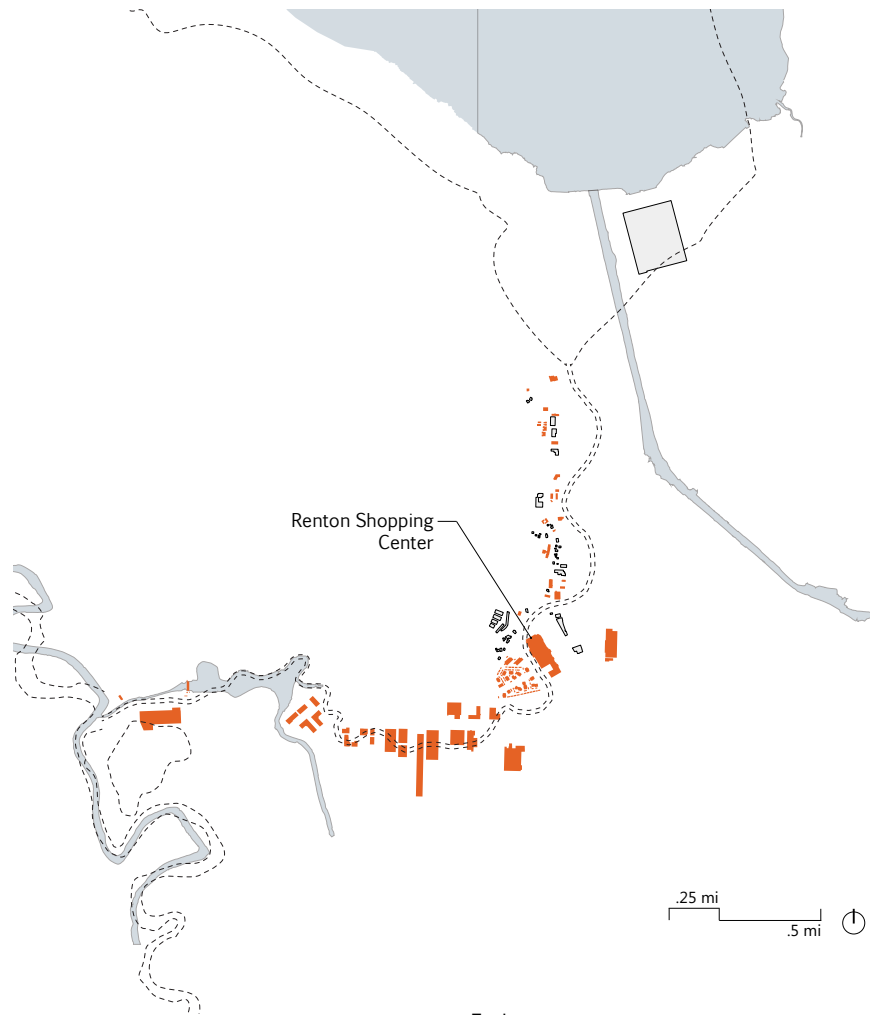

Figure 2.6 The orange buildings were constructed subsequent to the 1962 construction of Howard Hanson Dam.

Endnotes

1. Moses, Joseph. (1989). In an interview with David M. Buerge from *Renton, Where the Water took Wing*. California: Windsor Publication, 42.
2. Cuff, Dana and Roger Sherman. (2011). *Fast-Forward Urbanism: Rethinking Architecture's Engagement with the City*. New York: Princeton Architectural Press, pp. 10-31.
3. Buerge, David. (1985). "The Life and Death of the Black River," in *The Weekly*, Oct. 16-22, Seattle.
4. Ibid
5. Ibid
6. Ibid
7. http://www.historylink.org/index.cfm?DisplayPage=output.cfm&file_id=10221
8. http://www.historylink.org/index.cfm?DisplayPage=output.cfm&file_id=686
9. http://www.historylink.org/index.cfm?DisplayPage=output.cfm&file_id=3551

CHAPTER 3:
Theoretical
Framework

*History is the reconstruction, always problematic and incomplete,
of what is no longer.*¹

- Pierre Nora

The site for this thesis, Renton Shopping Center, sits squarely where the Black River once ran. Over time, prior to the site's current condition, the site became more and more crossed with infrastructure. Prior to making a proposal for the re-orientation of the site, it was critical to understand the theoretical and operative context of such a site. Three such contexts became apparent: memory and drosscapes; landscape infrastructure; and architecture + landscape architecture.

MEMORY + DROSS

Today the memory of the Black River is faint. The location of where it once ran is indiscernible without considerable research and anecdotal information from a generation now gone. The Native American people that lived with the Black River could not have conceived of it disappearing and as time moves steadily away from any memory of the Black River there will perhaps be a time when no one knows it was ever there. In the quote that opens

this chapter, from *Realms of Memory*, Pierre Nora accounts for the incompleteness and inaccuracy of that which we try to recall. For Friedrich Nietzsche, history is only relevant to the extent that it serves us. He wrote: "We want to serve history only to the extent that history serves life: for it is possible to value the study of history to such a degree that life becomes stunted and degenerate."² While the memory of the river is important, perhaps it is only important to the extent that it can serve life. Unlike the river I studied in Oslo, the Black River is not in a pipe but is much more permanently gone. Therefore, there is no question about whether or not to "bring the river back." Instead, there are questions of what parts of the river can return and why should they?

Alan Berger's concept of drosscapes builds off of the belief that the key to economic achievement is to spend and consume and that waste, of all kinds, is inherent to the process of

spending and consuming.³ One way cities waste space is simply by spreading out. According to Allen Scott, a city's economic base is made up of industrial districts outside of the city core.⁴ The construction of the Boeing plant on Lake Washington in Renton is an example of one such district. The strategy of locating manufacturing plants in urban peripheries (outside of Seattle in the case of the Boeing plant in Renton) contributes to the horizontal urbanization that produces an abundance of waste landscapes.⁵ The flat land and fresh water of the riverbed of the Black River along with its proximity to Seattle, made it a manufacturing hub in the early and mid-20th century. Infrastructure co-evolved with the needs of manufacturing and a network of railroads, highways, and electricity crossed and connected the land over time. As means of communication increasingly replace means of transportation, movement from older parts of the city to outlying areas will only increase, necessitating more infrastructure and more loss in the process.⁶

Renton Shopping Center sits in the crosshairs of infrastructure constructed for a bygone era of manufacturing. As Renton evolves from peripheral manufacturing center to a more populated city, its infrastructure too will need to change and the spaces leftover from the infrastructure of manufacturing will no longer be leftover. In an interview with *Metropolis Magazine*, landscape architect Julie Bargmann put it succinctly: "The aim is to make the transformation of marginal terrain central to the next generation's work."⁷

LANDSCAPE INFRASTRUCTURE

"Infrastructure acts as the agent between social life and the architecture that accommodates it."⁸

Landscape infrastructure is a movement within the discipline of landscape architecture that recognizes the shortcomings of the mega-projects of the 20th Century. Additionally and perhaps counterintuitively the landscape infrastructure movement believes that the

importance of infrastructure is not fading but surging. As processes of decentralization take hold and cities turn into regions, there will be a need for more infrastructure.⁹

The Renton Shopping Center site is crossed with infrastructure. First the river was used as infrastructure, then the BNSF constructed tracks to the south of the site. Today, additional infrastructural networks of roads, power, and stormwater conveyances cross the site. The construction of the infrastructure initially created the 'leftover' space that Renton Shopping Center now occupies. For a transformation of the site to occur, modifying and expanding the infrastructure that crosses the site will be critical. The infrastructure of the 20th Century was mono-functional and as such created wasted spaces in its wake. Expanding infrastructure to perform polyfunctionally is critical to the regional-style development of the 21st century. While cities and people tend to lend permanence to infrastructural projects, they are actually relatively fragile.¹⁰ A shift

in perception of infrastructure as static and permanent to infrastructure as dynamic and morphing opens up possibilities of what it can be. Using transit infrastructure – bicycle or perhaps train in the case of Renton Shopping Center – as a legible and resilient system can create a framework for the emergence of a new city within the fabric of the old.¹¹ The infrastructural project began as a means of facilitating economy. Today, as the infrastructural projects of the 20th century begin to fail, there is an opportunity to re-define their contribution to economy by adding new capacity. At Renton Shopping Center this means that the unbuildable power corridor can adopt a regional bike network and community gardens. The little-used BNSF rail can be part of a regional commitment to connecting people from Lake Washington to Puget Sound. The subsurface water conveyances can inform more saturated surface conditions above. Pierre Belanger, Associate Professor of Landscape Architecture at Harvard University, insists that

ecologists, scientists, and historians must act as historians and the project of landscape infrastructure is the place for them to do so.¹²

ARCHITECTURE + LANDSCAPE

Architecture and landscape architecture are unique disciplines in both fundamental and superficial ways. Fundamentally, architecture works specifically with enclosure while landscape architecture works beyond enclosure. The discipline of architecture firmly belongs in the human-realm while landscape aspires to move between human and natural. Perhaps more superficially, architects design 'inside' and landscape architects design 'outside'. The dichotomies that separate landscape architecture and architecture trace back to the western polarity that opposes humans and nature.¹³ The issue with opposing humans and nature is that it suggests a hierarchy when in fact the two are inextricably intertwined. There is no nature without humans and no humans without nature. The same goes

for architecture and landscape architecture. It may be necessary to separate the two disciplines professionally and academically, but at the root they both mediate between blurred notions of human and natural. The fact that architecture and landscape architecture exist as disciplines unto themselves points to the robustness of each but the intersection of the two is fertile design territory.¹⁴ The 'natural' be it in an urban environment or elsewhere, must be understood as constructed much like a building would be. There is a growing sense that, as cities grow priority will need to be accorded to landscape as opposed to freestanding built form.¹⁵ However according priority to one or the other supports the false notion of the human-nature dichotomy. Instead the two disciplines must be considered in tandem, not as a single discipline, but as two that strengthen each other through co-evolution.

Endnotes

1. Nora, Pierre. (1989). "Memory and History: Les Lieux de Memoire," in *Representations*, No. 26. California: University of California Press, p. 8.
2. Nietzsche, Friedrich. (1983). *Untimely Meditations*. Trans. R.J. Hollingdale. Cambridge: Cambridge UP, p. 59.
3. Berger, Alan. (2006). *Drosscape*. New York: Princeton Architectural Press, 43.
4. Ibid, 55.
5. Ibid, 58.
6. Ibid, 64.
7. Bargmann, Julie. (2012). "New Architecture Faces the Future," in *Metropolis*, <http://archive.today/wRKV>
8. Seewang, Laila. (2013). "Skeleton Forms: The Architecture of Infrastructure," in *Scenario Journal*, <http://scenariojournal.com/article/skeleton-forms-the-architecture-of-infrastructure>
9. Belanger, Pierre. (2013). "Landscape Infrastructure," in *Harvard Design Magazine*, No. 36, Cambridge, MA: Harvard University Graduate School of Design.
10. Belanger, Pierre. (2012). "Landscape Infrastructure," Harvard Graduate School of Design, Mar. 24. Conference. <http://www.youtube.com/watch?v=BLQkslziVEY>
11. Czerniak, Julie. (2013). "Landscape's M.O." in *Formerly Urban*, edited by Julie Czerniak, New York: Princeton Architectural Press, 155.
12. Belanger, Pierre. (2012). "Landscape Infrastructure," Harvard Graduate School of Design, Mar. 24. Conference. <http://www.youtube.com/watch?v=BLQkslziVEY>
13. Balmori, Diana and Joel Saunders. (2012). "Interface: Between Landscape and Architecture," Harvard Graduate School of Design, Jan. 31. Lecture. <http://www.youtube.com/watch?v=SXPohlrivwU>
14. Weiss, Marion and Michael Manfredi. (2011). "Evolutionary Infrastructures," Harvard Graduate School of Design, Oct. 11. Lecture. http://www.youtube.com/watch?v=mJH_bLPKOAU
15. Frampton, Kenneth. (1995). "Toward an Urban Landscape," *Columbia Documents*. New York: Columbia UP, 120.

CHAPTER 4:
Design Approach
+ Design

*ALL ROADS AND FREEWAYS LEAD TO
RENTON SHOPPING CENTER*

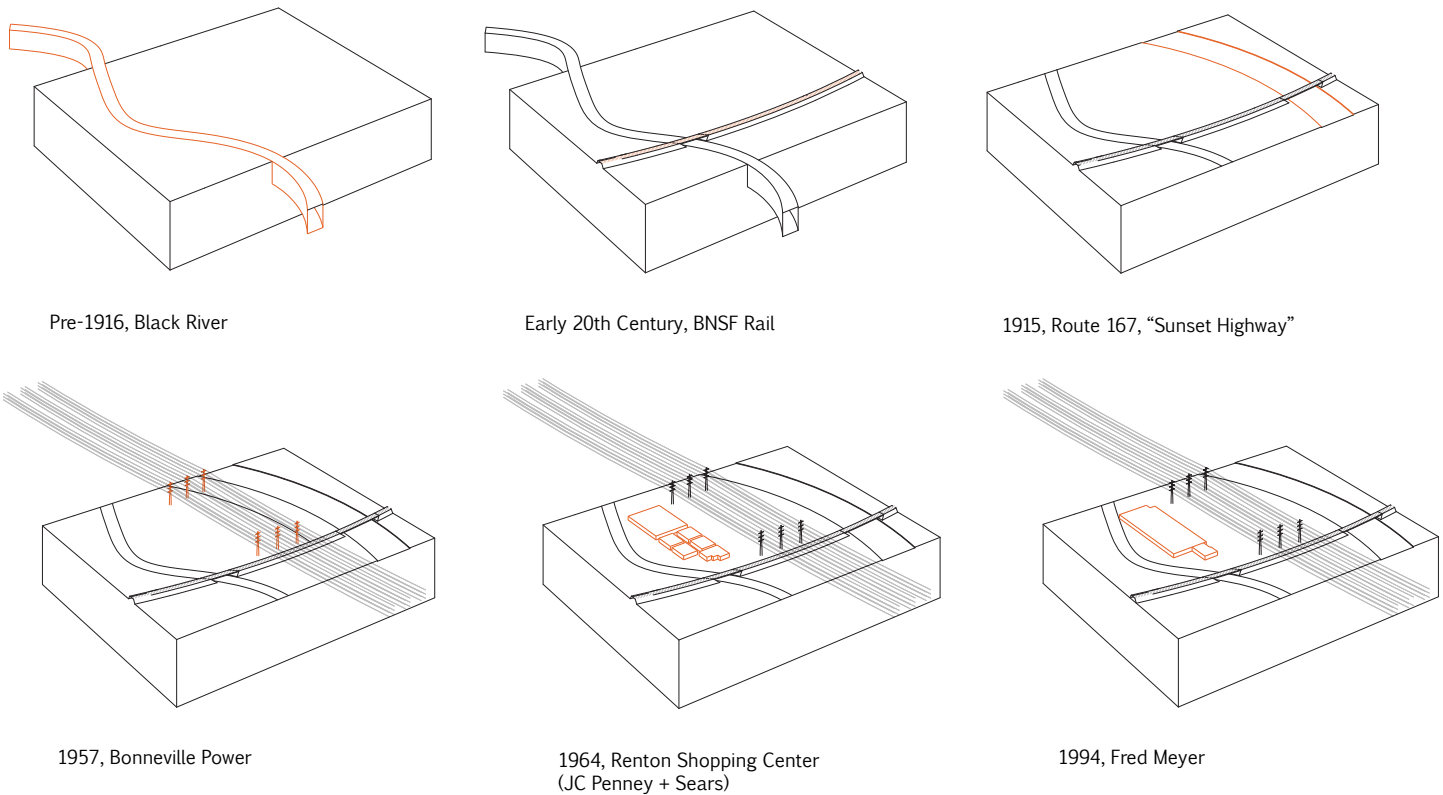

Figure 4.1 Renton Shopping Center site succession diagrams

The idea of succession and change over time is critical to this thesis and served as the starting point for the research and design of the site in Renton. In a lecture titled *Evolutionary Infrastructures*, Marion Weiss described the design process as a mess where you jump in the middle and swim and paddle to any edge you can find.¹ The history of Renton Shopping Center and the Black River served as my edge. The diagrams in figure 4.1 illustrate the site's evolution from meandering river to 170,000 sf Fred Meyer. The Renton series of diagrams mirror those that I propose for the succession of urban rivers - over time more and more infrastructure occupies the site. In Renton, manufacturing industries moved into spaces along the Black River on either side of this particular site; here however, large-scale commercial moved in before industry had the

chance. The 1964 construction of Renton Shopping Center followed the construction of Howard Hanson Dam and preceded Renton's eventual re-branding as a shopping center (this legacy is evidenced in the opening quote of this chapter, which the city placed in a variety of places including maps). Today the ghost of the river is evident in how the riverbed is used and zoned (see figures 4.2 and 4.3). The riverbed is entirely zoned light industrial and there are virtually no parks or public spaces. To the west, parks and public spaces cluster around the Duwamish River and to the east the same goes for public spaces around the Cedar River. Additionally, multi-family residencies to the west are separated by the industrial riverbed from Renton's downtown core to the east.

PUBLIC
OPEN SPACE

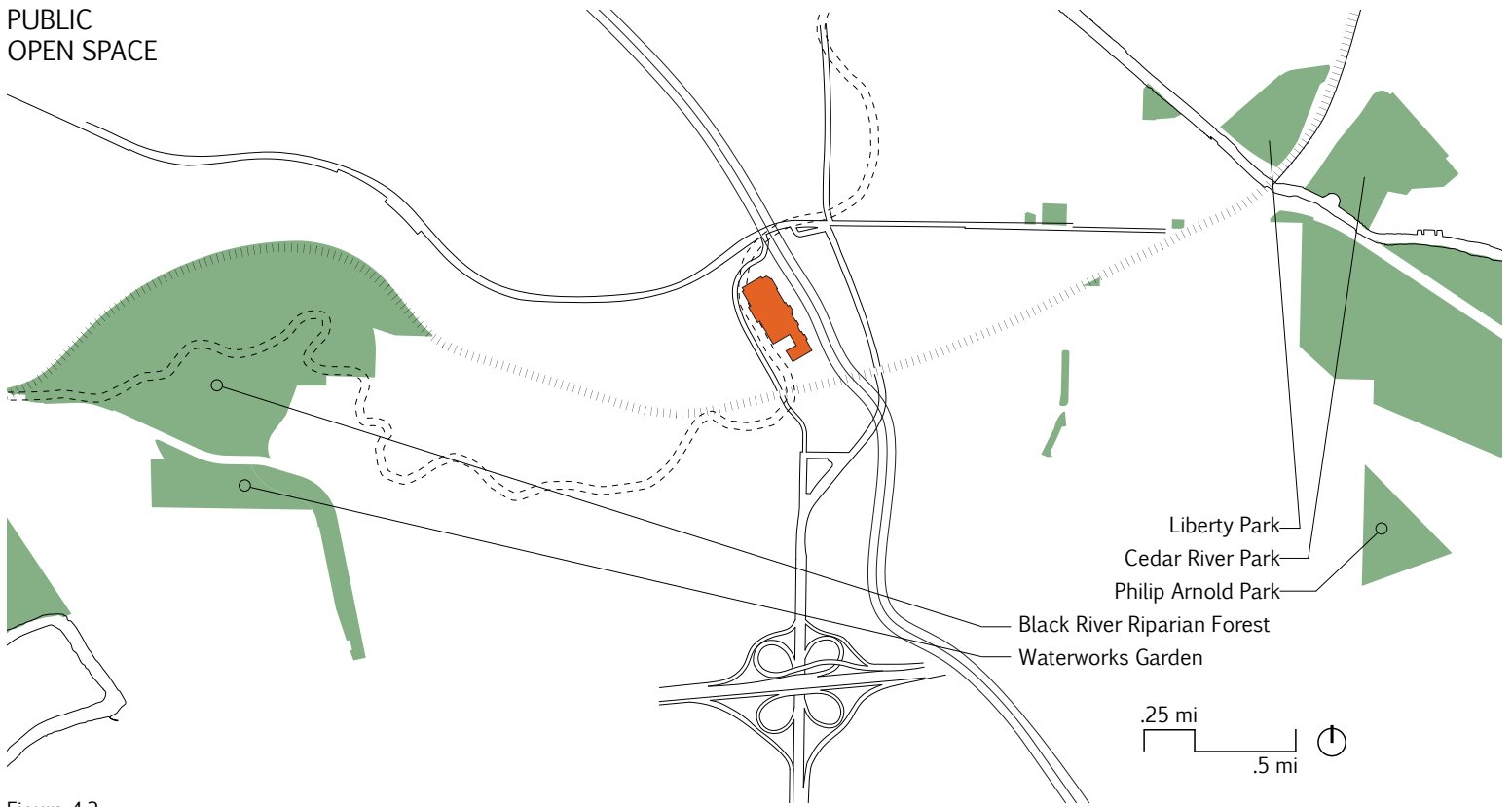

Figure 4.2

ZONING

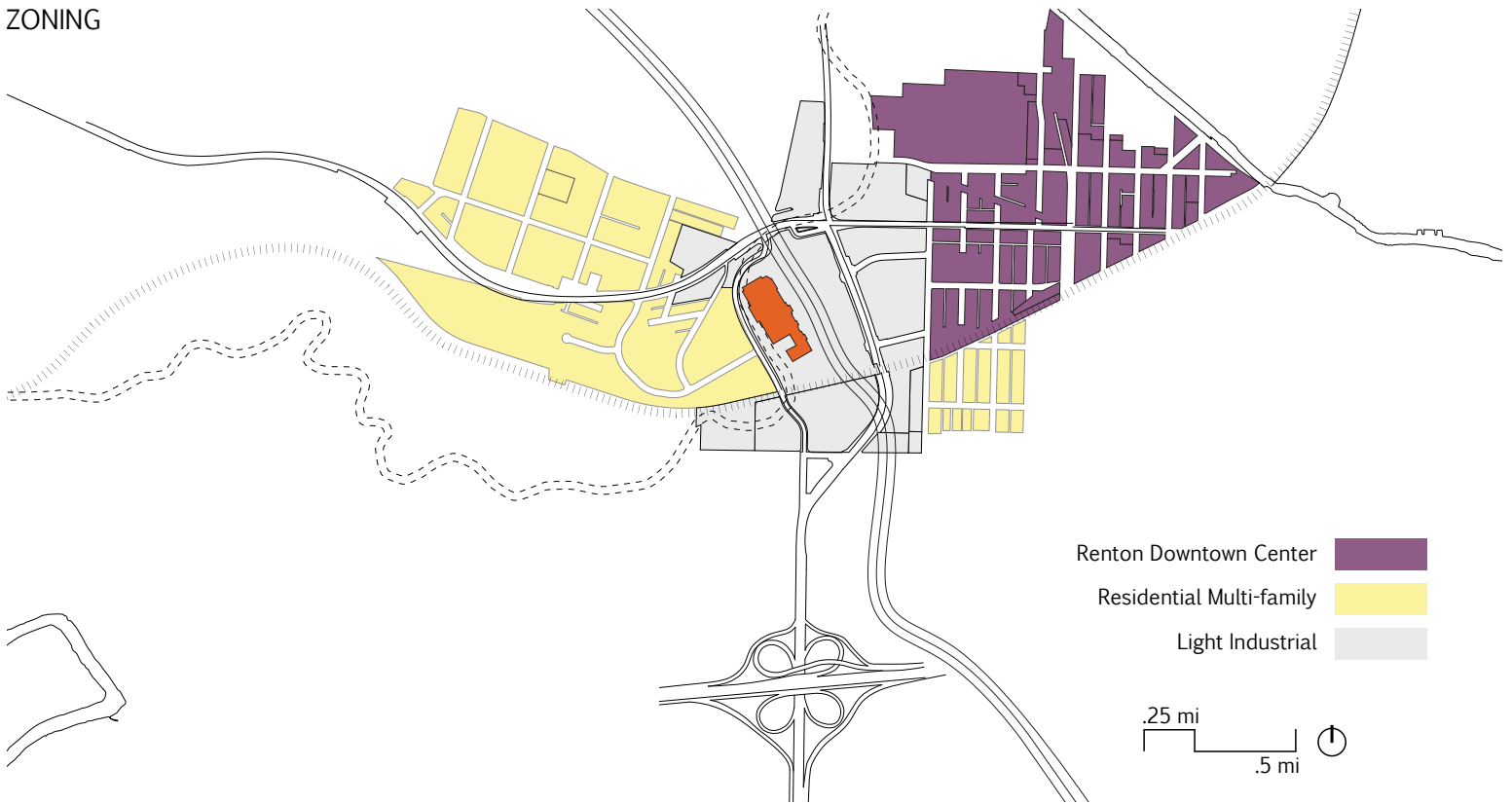

Figure 4.3

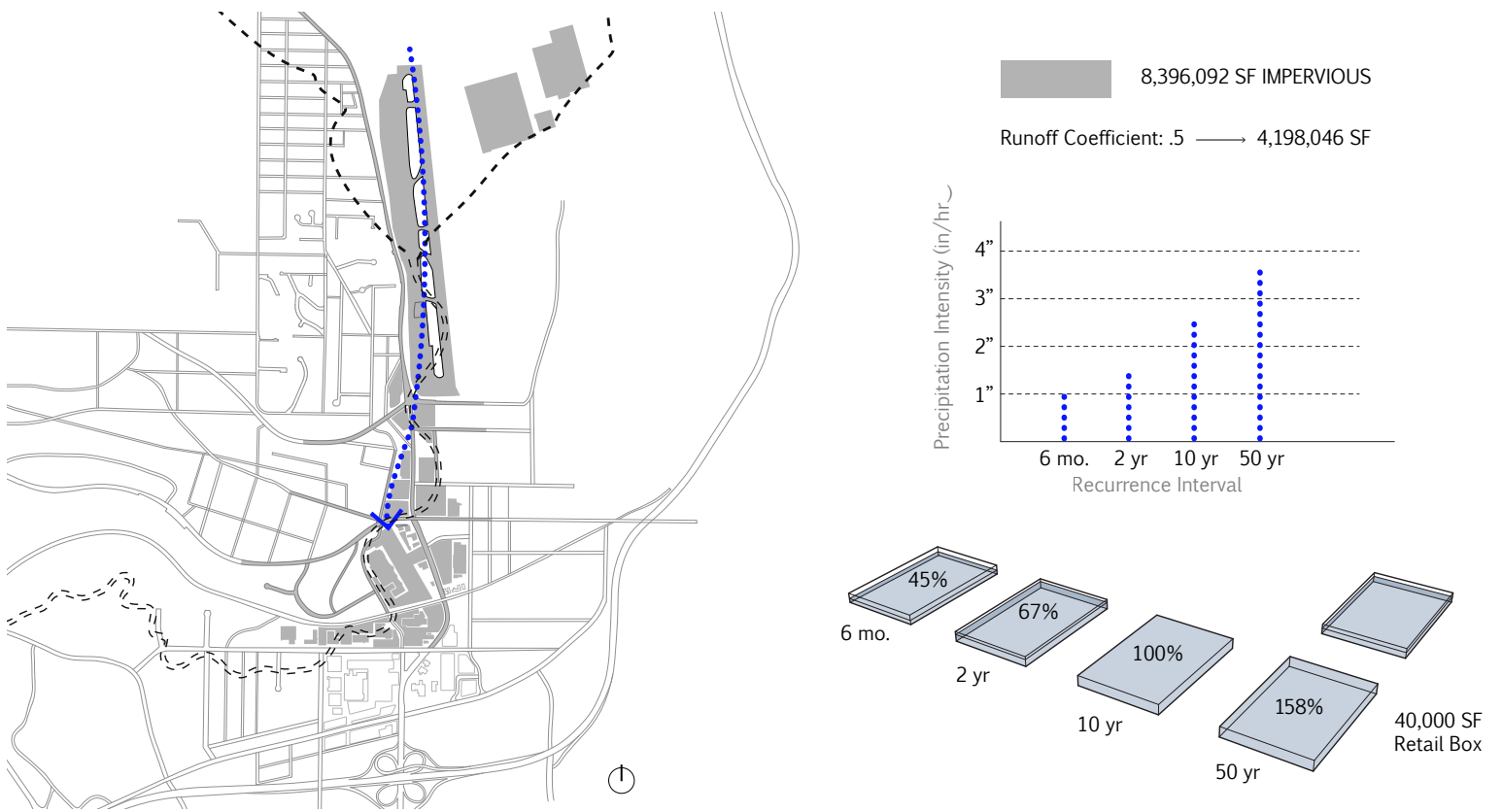

Figure 4.4 Impervious pavement where the Black River once ran and rainfall data

A result of the paving over of the riverbed is an immense amount of impervious surface (figure 4.4). In the space between the Fred Meyer and Lake Washington upwards of eight million square feet of impervious surface covers the original riverbed. The process of paving over the riverbed was sparked by the construction of Howard Hanson Dam in 1962; gradually, since that time, the riverbed disappeared. In figure 4.4 a stormwater runoff coefficient of .5 is assumed for the area. This number is based on the Rational Method Runoff Coefficient Table and is conservative given the amount of development (depending on the soil type, the industrial runoff coefficient can be as high

as .86).² This thesis proposes that the site of the Fred Meyer, atop what was the Black River, return to a state of saturation for two reasons: to connect Renton's disparate parts (downtown and residential), and to create an ecological asset from a site that once was just that.

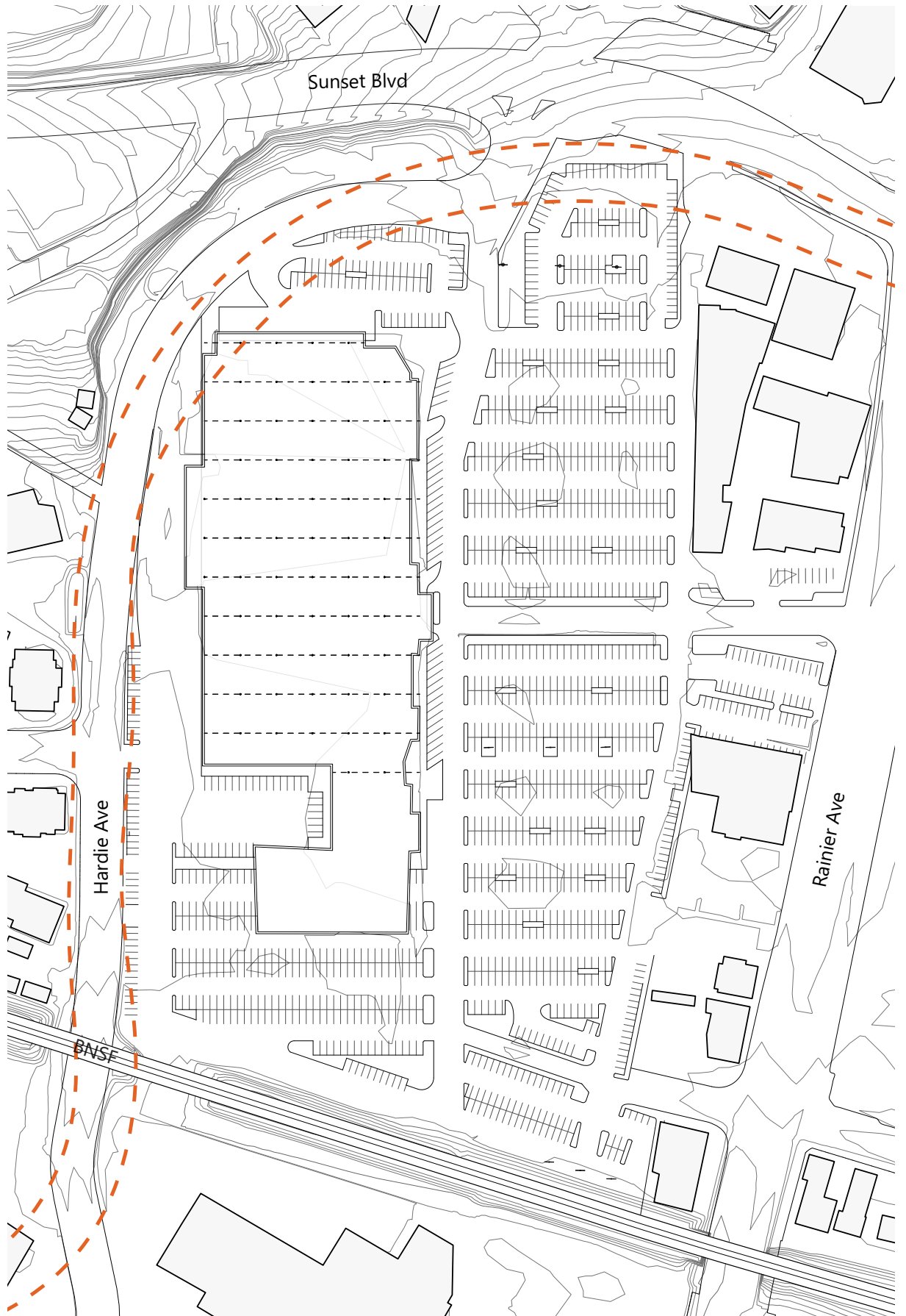
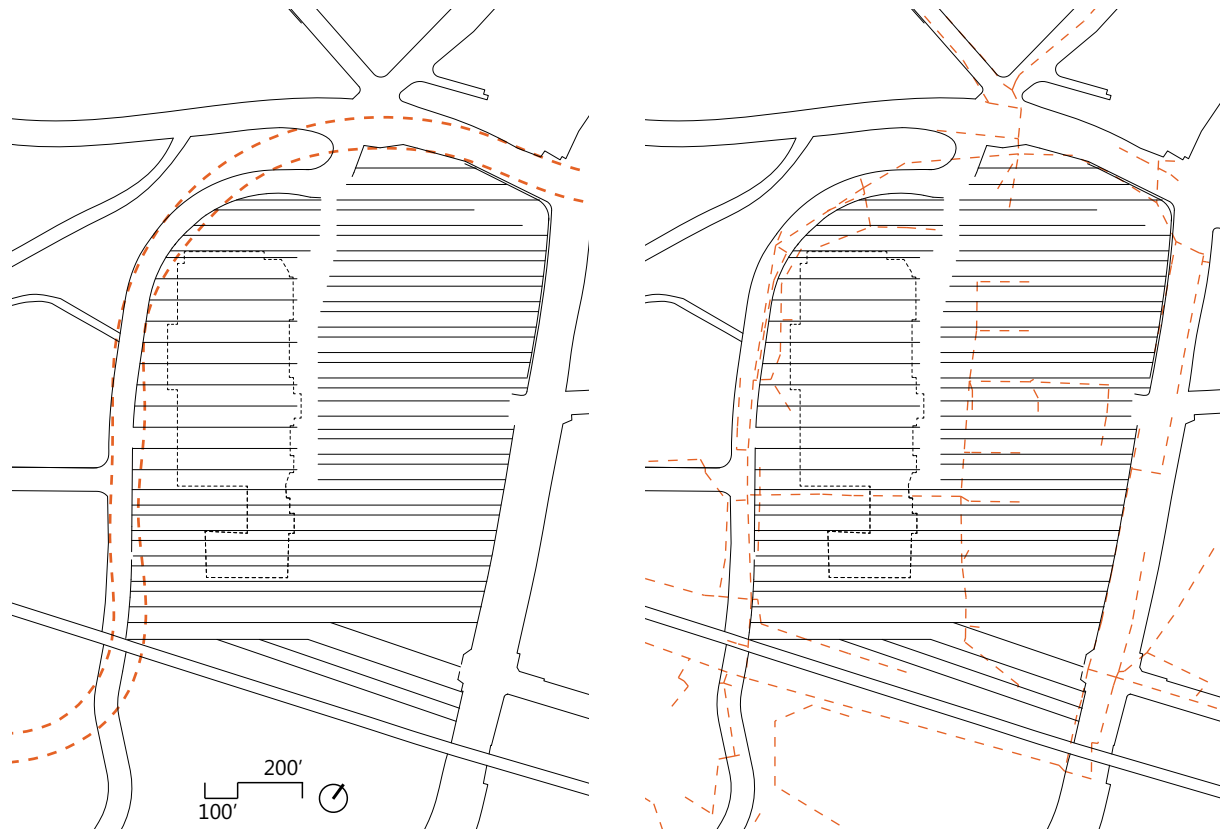

Figure 4.5 Existing site

Figure 4.6-7 On the left is the organizational grid of the Fred Meyer and the parking lot with the original course of the Black River dashed in; on the right is a map of the conveyances that run below the surface of the site.



The process of shifting the site from divisive big box to connective asset began with an analysis of what is there. The existing site (figure 4.5) reveals a highly structured, gridded organization that optimizes the site for big box retail. The Fred Meyer itself measures 572 feet long, 313 feet wide and 28 feet tall. Part of what's striking however is that in spite of its massive dimensions the visitor is not overwhelmed by the building's scale. Perhaps because of its squat proportions but even more likely due to the massive parking lot in which the building sits. The parking lot more than doubles the square footage of the building and has room to accommodate over 1,500 parked cars. The majority of the parking spaces are on the east side of the building, between the

main entrance and Rainier Avenue South, which connects to the interstate a half-mile south of the site. The car and the ability of the building and the site to accommodate the car are obviously of utmost importance. Beneath the surface parking, a network of conveyances performs the stormwater management task that once belonged to the river (see figure 4.7). In the sea of pavement that is the parking lot, the car is clearly prioritized. All signage, whether painted on the pavement or posted to a pole, is directed at the organization and movement of cars. Once out of his/her car, no two pedestrians navigate this undifferentiated terrain the same way. In a sense, this experience prepares the visitor for his/her experience once inside the Fred Meyer.

A 52'x48' structural grid defines the space of Fred Meyer in Renton. The columns, beams and joists are steel, the ceiling is exposed metal decking and the floor is the concrete slab upon which the building stands. In areas where merchandise such as jewelry, watches, and clothing are sold, there is a hung ceiling and carpet or vinyl flooring. These spaces offer some differentiation to what is otherwise an uncompromised 52'x48' grid of columns. At the building's three main entrances, window openings puncture the CMU enclosure. The windows at the entrances hold the only pieces of glass in the building. The space is inundated with signage that directs shoppers to endless aisles of food, drink, utensils, and more. Apart from the signage indicating where you are – and the small, specialty merchandise areas – the experience of shopping in one part of the store is the same as every other. In fact, the experience of being in any given Fred Meyer is the same as any other. In building its brand Fred Meyer found value in homogeneity for its

familiarity and its efficiency.

The connection between the automobile and the building is most famously recognized, or perhaps desired, by Le Corbusier. In *Toward an Architecture*, Corbusier compares the perfection of the Greek Temple, culminating in the Parthenon, with the evolution of the design of cars – believing they too would reach a perfect state. Corbusier dreams that if a similar standard could be introduced with the design of a house, then a similar level of perfection and efficiency could also be reached. The Fred Meyer in Renton is the extreme outcome of Corbusier's desires. The efficiency of capitalism eliminated the meandering river upon which the building stands. The same forces site the building in a sea of parking seamlessly connected to the interstate highway. The building's near-perfect square grid internalizes the Jeffersonian grid that organizes automobile travel. Fred Meyer then represents the actual outcome of another errantly utopic Corbusien vision.

Much more so than the American silos romanticized by Corbusier, the Fred Meyer in Renton is a building of sheer utility. It is a perfect example of the Fordist system of mass production that fueled city organization in the first half of the 20th century.³ The expansive building is ultimately consumed by the far more expansive systems of movement to which it belongs. To be clear the systems of movement to which Fred Meyer belongs are primarily the interstate or the road and the Kroger Company's regional and national network of storage, containers, and shipping. Without the Fred Meyer the systems that are the interstate and Kroger would clearly still exist; the opposite is not true. This subversion of hierarchy (the importance of the system or network over the places it connects) is easily readable in the plain construction of the Fred Meyer building. The building is important chiefly because it provides a place for systems of movement to pause and be redistributed. The non-architecture of the Fred Meyer – CMU walls,

exposed metal deck ceiling, bare concrete floors – expresses the repression of the building in relationship to its parent systems while its ambiguity permits it to be everything, anything, and nothing as needed. Over time, infrastructure does not dissipate but becomes further entrenched in the space it occupies.⁴ The utilitarian architecture that emerges from this context has an average shelf-life of twenty years and its quality of construction reflects that short span.⁵

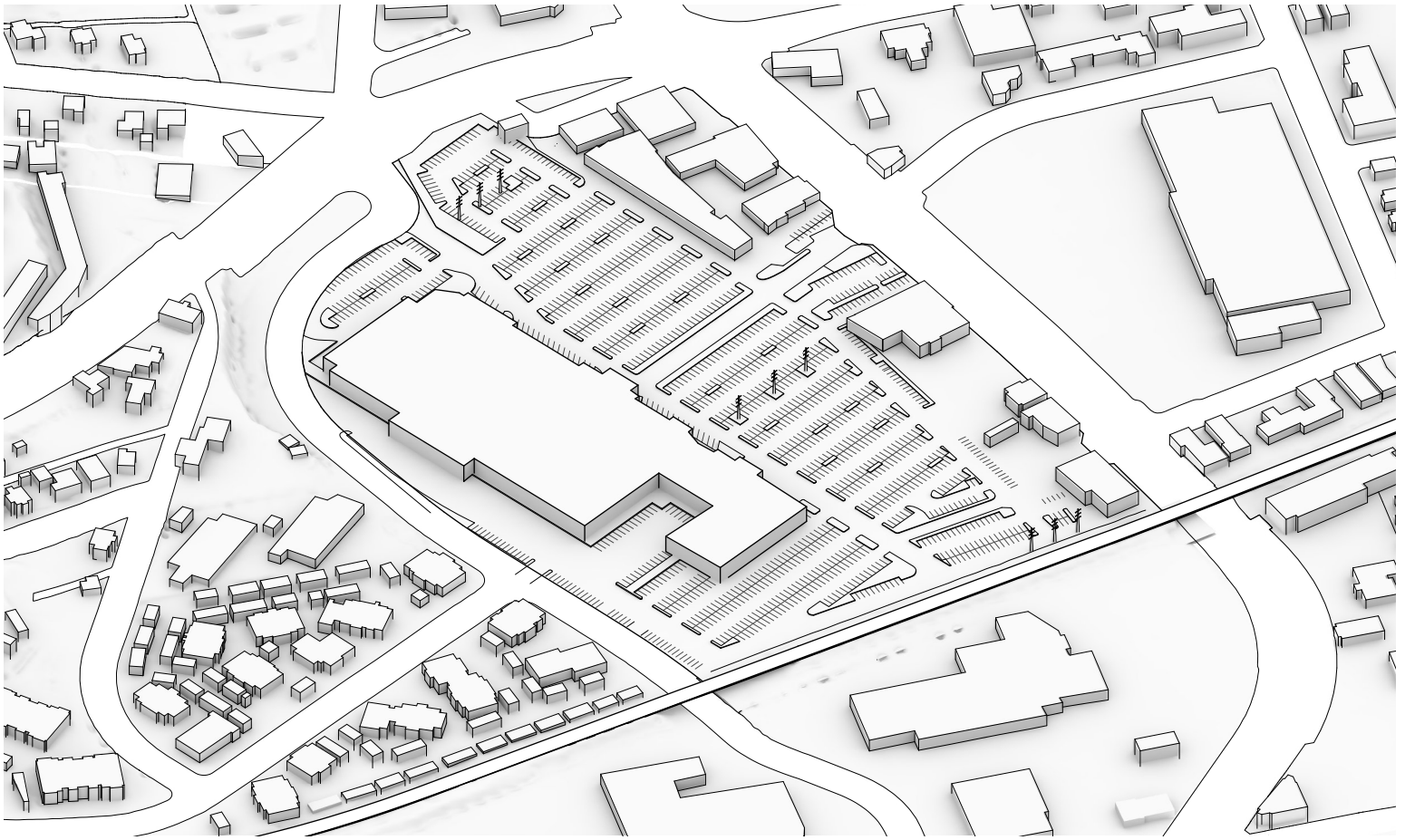

Figure 4.8 Existing Condition

Shifting the site to return to saturation begins with cuts in the surface parking lot, located within the site's grid and above and parallel to the subsurface conveyances. Figures 4.8-4.11 describe the site's transformation through a series of axonometric drawings. Figure 4.8 shows the site as it stands today, with parking and power lines sandwiched between the Fred Meyer and Rainier Avenue. As Renton develops there will be a need and an opportunity for the site to accept more water and therefore more incisions into the surface parking are necessary. Figure 4.9 shows the initial cuts into the surface parking lot, with the organizational grid overlaid in red. The topography of

the site is such that water moves north to south, like the Black River once did. Water collects in the "cuts" in the surface parking lot and, as needed, filters to the existing, hard infrastructure below the surface. Figure 4.10 shows how, over time, the amount of cuts could increase, thereby increasing the site's capacity for stormwater. The cuts occur in the southwest portion of the site because it is mostly vacant and because it is currently the lowest point on the site, so water naturally flows there.

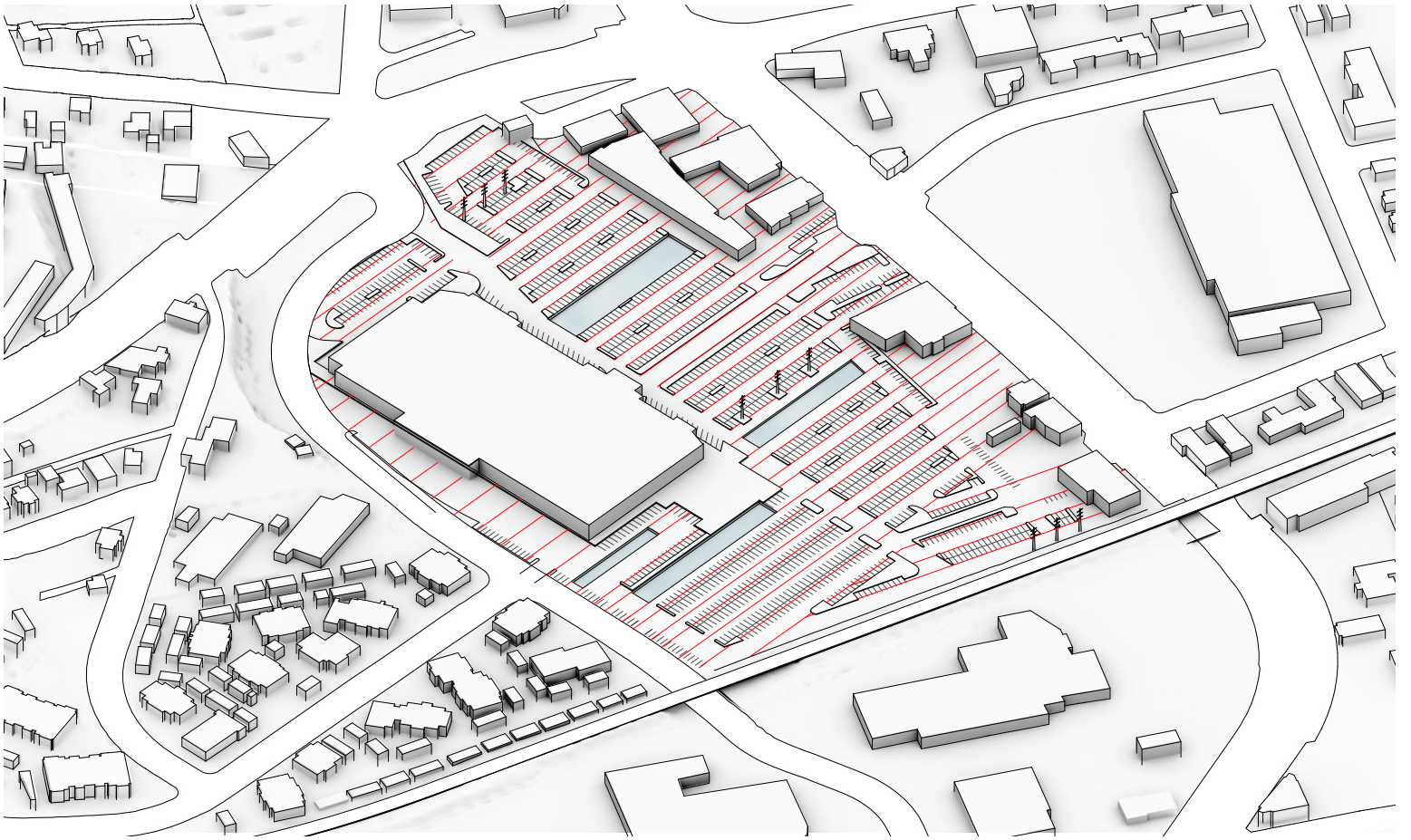

Figure 4.9 First "cuts"

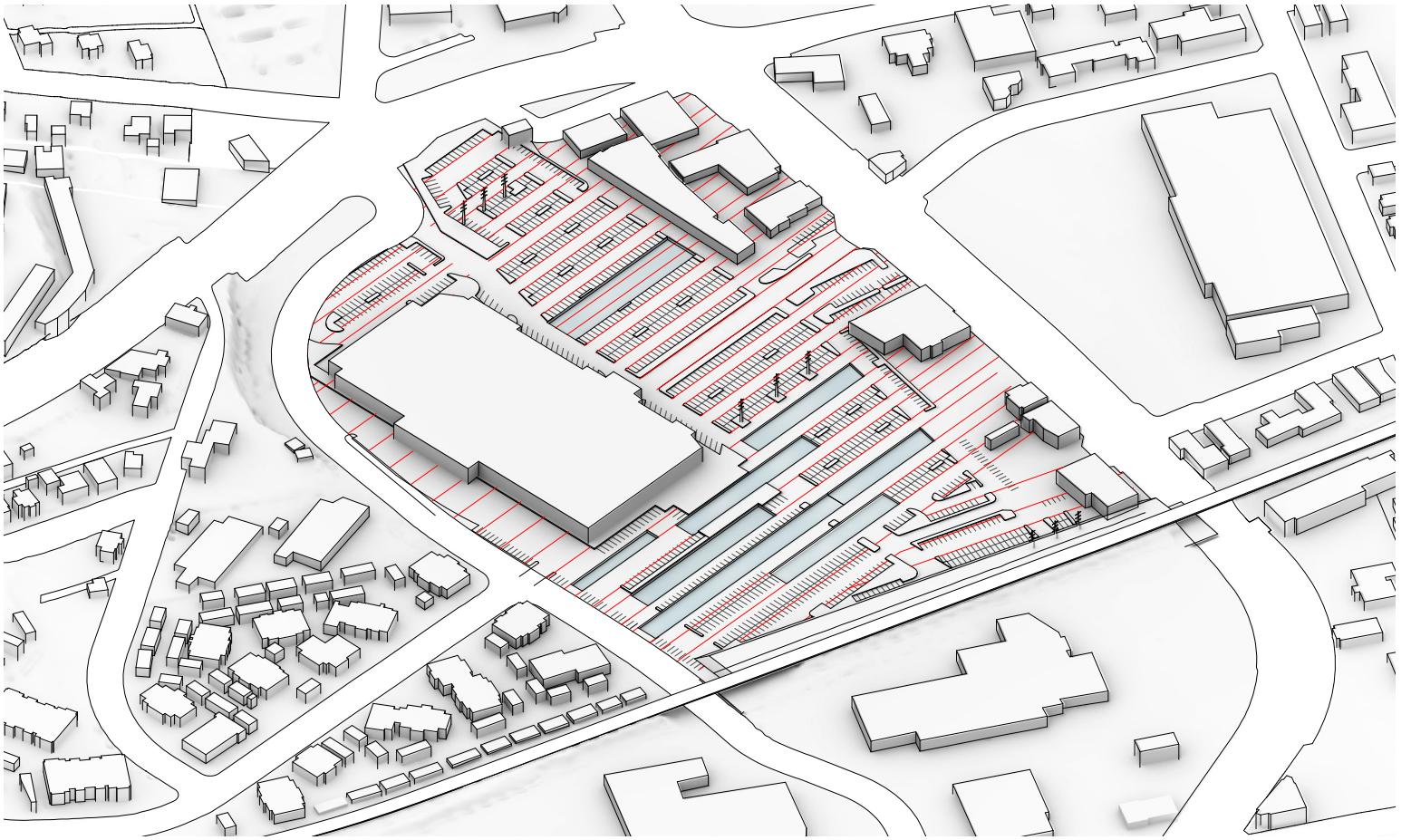

Figure 4.10 Next “cuts”

RISE + FALL OF BIG BOX



Figure 4.11 Innovations in the way we shop and ship goods have impacted cities over time. Today, the big box model is primed to lose out to internet shopping.

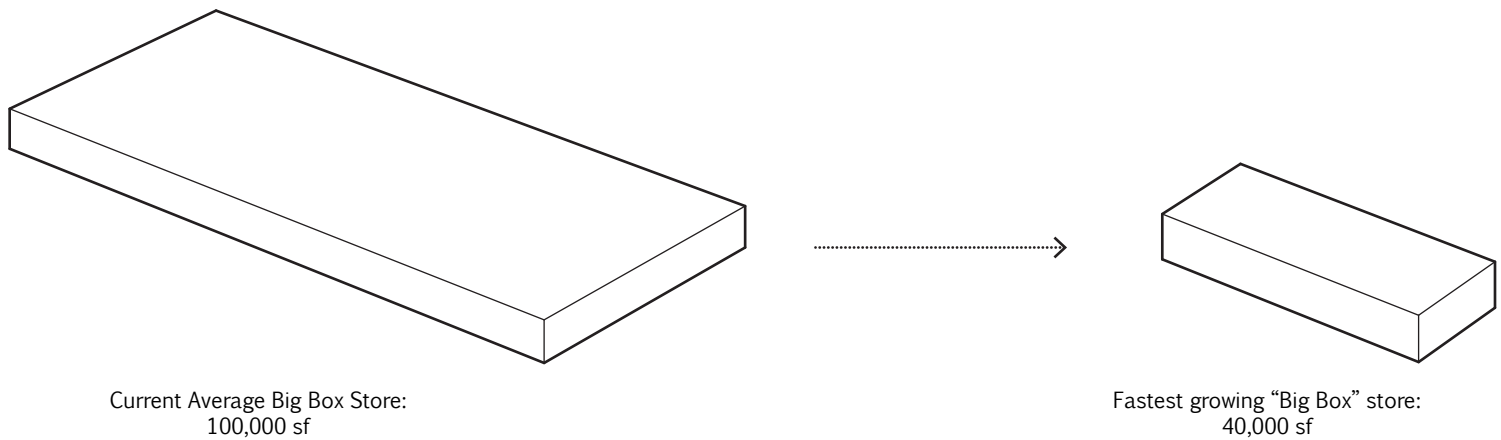

Figure 4.12 Big Box companies are increasingly interested in stores sized 40,000 sf or smaller.

Simultaneously, the big box model of retail is dying. Big box retail was attractive because of its one-stop efficiency; today, that efficiency is found on the internet. Over time, there have been several critical advances in consumer efficiency, beginning with the shopping cart (figure 4.11).⁶ The one-stop Big Box came into prominence along with the car and road network. Today that model is completely

dated. While the big box model of retail is dying, the companies that own them are not necessarily. Wal-Mart for example, is instead accelerating its rollout of stores sized 40,000 sf or less.⁷ The current average big box store size is 100,000 sf (figure 4.12).⁸

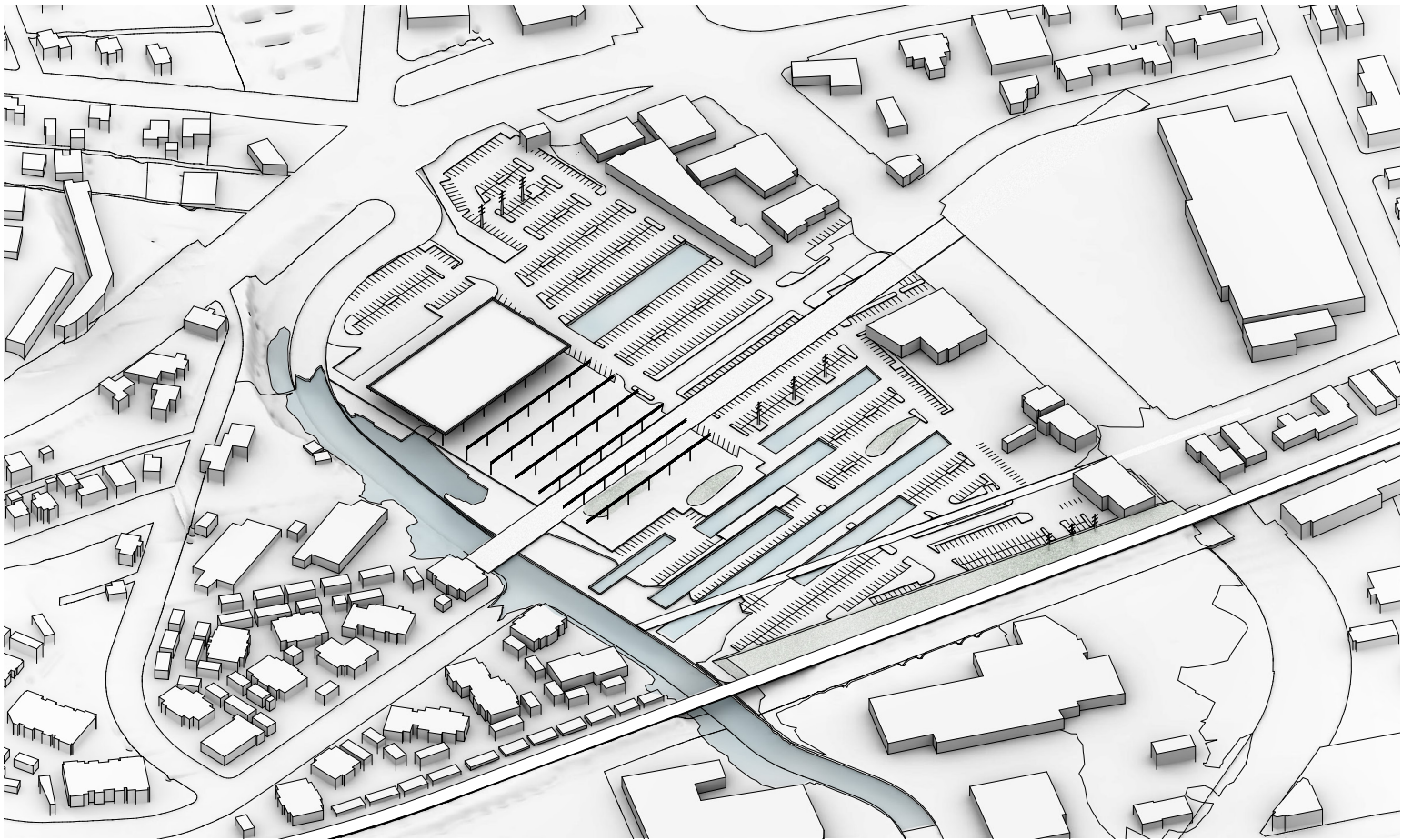

Figure 4.13 River emerges in flood conditions, Big Box recedes to 40,000 sf

The final axon diagram (figure 4.13), as well as the site plan (figure 4.14), shows the Fred Meyer receding from 170,000 sf to 40,000 sf while the surface parking lot is increasingly saturated. At this phase, the program of the site remains partially devoted to big box retail while much of the surface parking is accepting, absorbing, and slowly conveying rainfall the way the site used to. Figures 4.13 and 4.14 show Hardie Avenue nearly completely flooded, with water occupying the site's lowest contour, perhaps a former boundary of the Black River. Figure 4.15 is a perspective image of flooded Hardie Avenue, looking north toward what remains of the Fred Meyer structure. The berm of the BNSF rail at the south edge of the site is

extended to accommodate a bike trail. The BNSF rail is in fact currently a rails to trails candidate, with the organization 4Culture leading the transformation efforts.⁹ Beneath the power lines, a regional trail connecting Chief Sealth Trail to the 4Culture trail positively charges the 'dead' space beneath the power lines. The steel frame of the Fred Meyer remains as scaffolding to support future growth, built or vegetated.

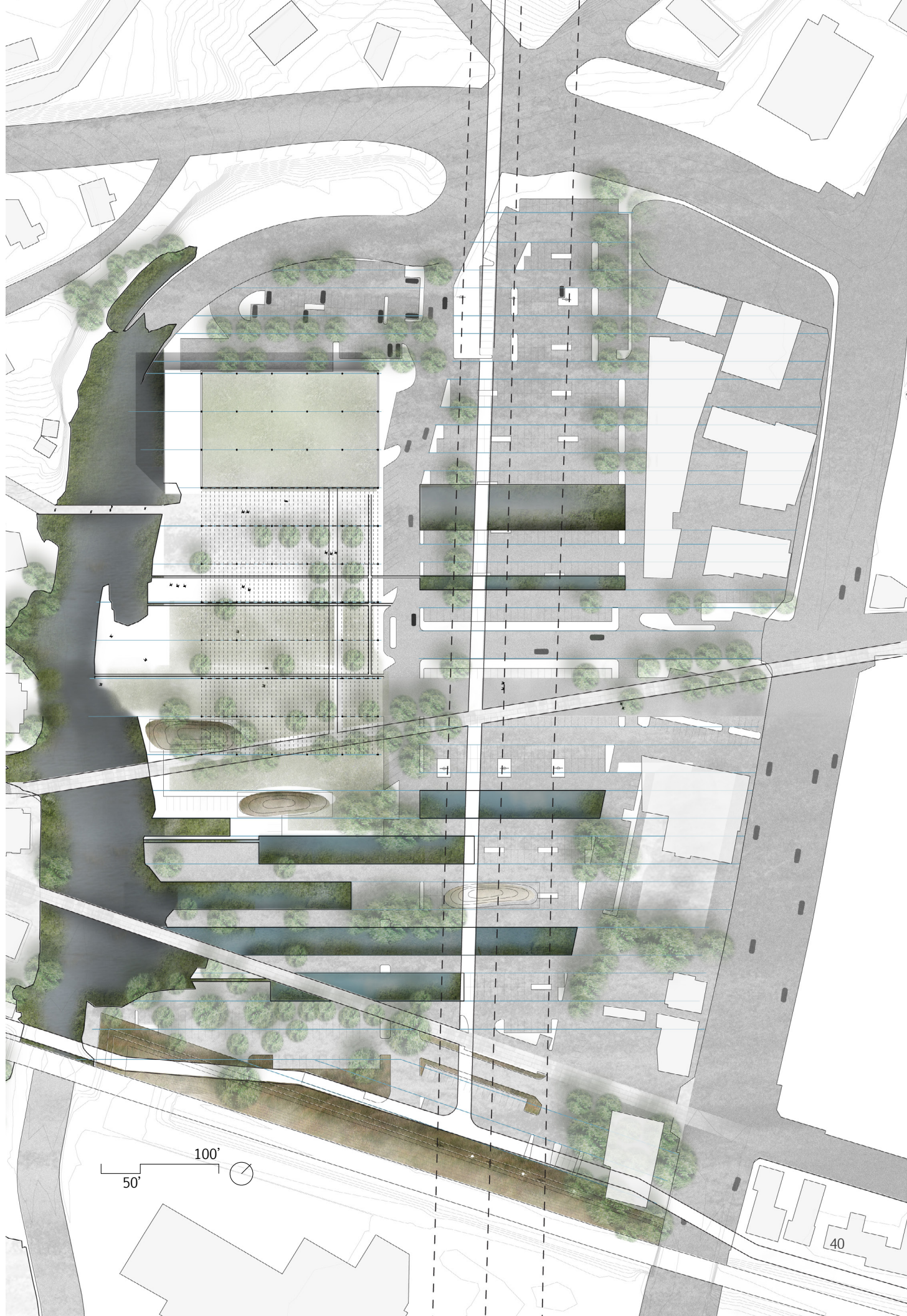

Figure 4.14 First Phase proposed site plan

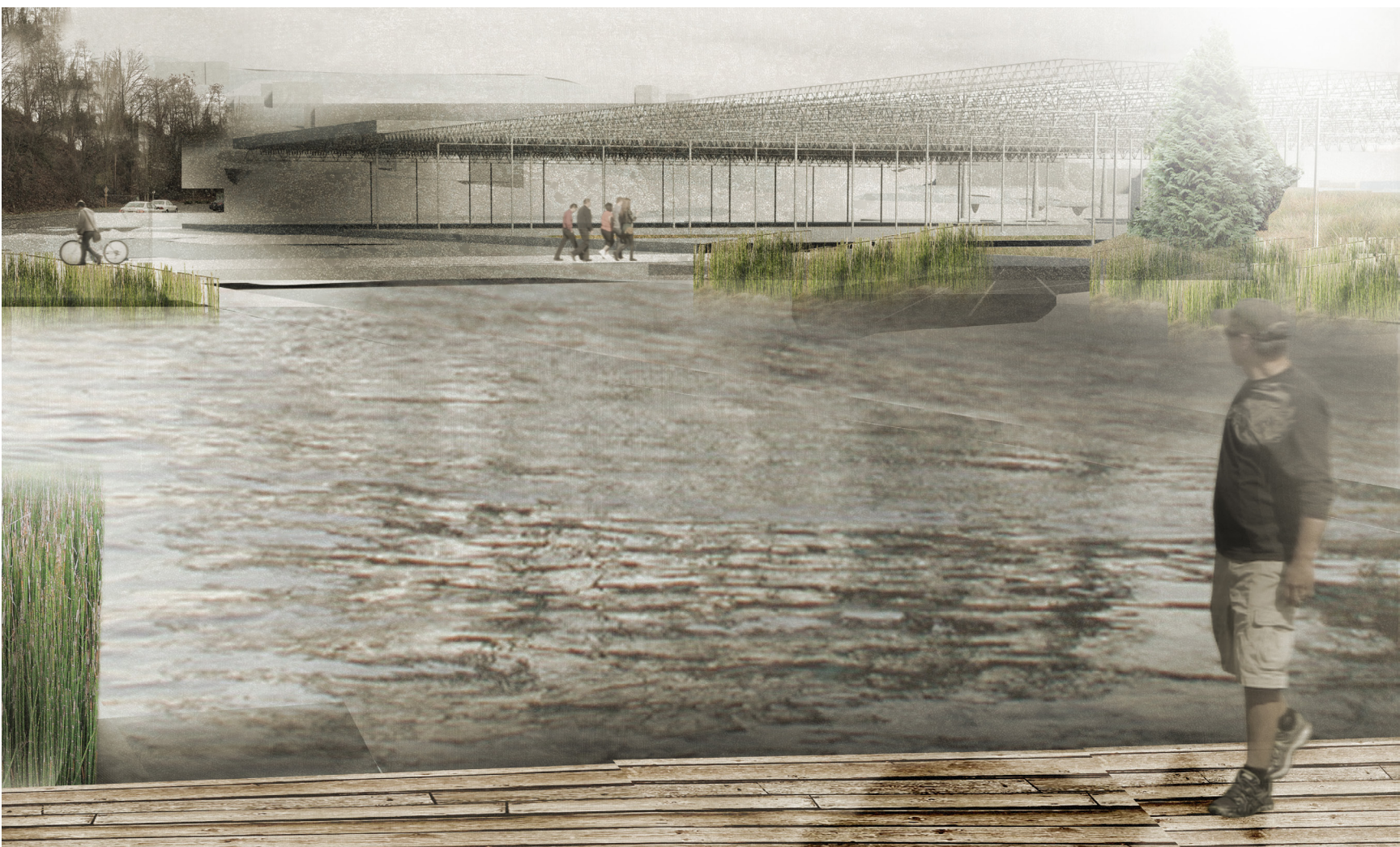

Figure 4.15 Perspective
looking across a flooded
Hardie Avenue, where the
Black River once ran, toward
the old Fred Meyer structure

DIAGRAMS

The landscape architecture diagram for the transformation of the site builds off of a 'cut + fill' logic (figure 4.16). Where there are opportunities for the site to accept more water, there are cuts. The cuts in the surface parking lot are linked beneath the surface by the existing conveyances. Over time as the amount of cuts increase, the permeability of the site can start to resemble that of the soft, saturated soil that once comprised the riverbed. One benefit of this is an enhanced capacity for the site to hold water to either re-charge the groundwater or more slowly release it to the city conveyances. Additionally, the material that is cut can be processed on-site so that it can be used as fill to provide drier and more stable growing conditions. As referenced in Chapter 1, the cross-section of natural riparian corridors is quite varied offering different growing environments preferable to a variety

of species from larger wood (*Thuja plicata*, *Picea sitchensis*, and others) to grasses and willows (*Carex obnupta*, *Salix viminalis*, etc.) In the appendix are diagrams that describe the planting opportunities and strategy in more detail.

LANDSCAPE ARCHITECTURE DIAGRAMS

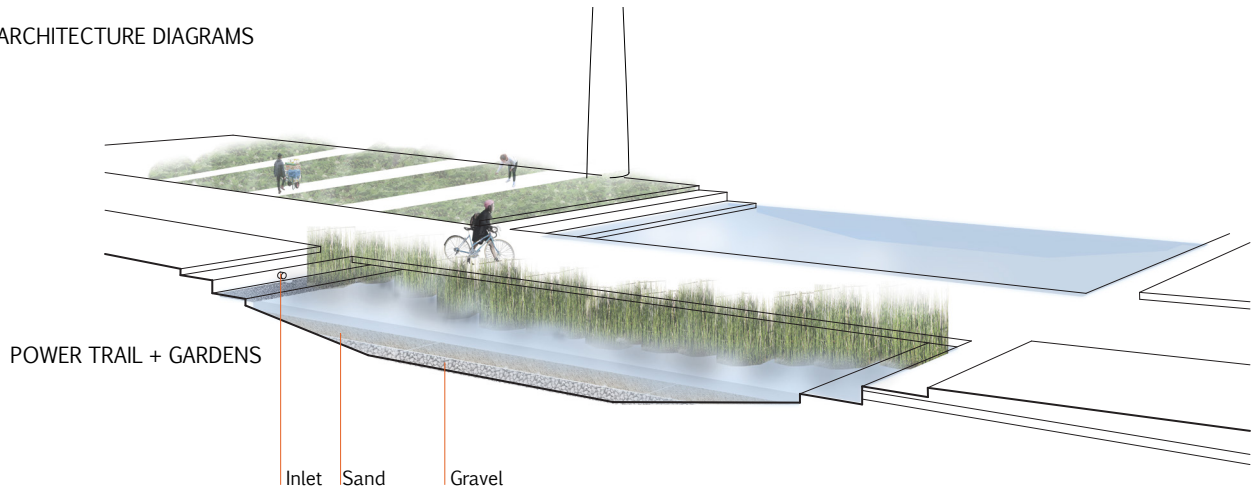

CUT + FILL

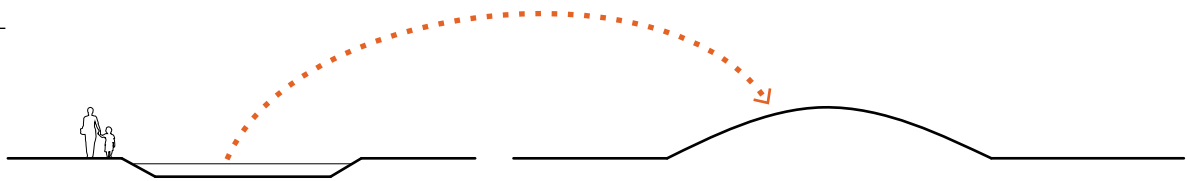

SATURATE + FILL

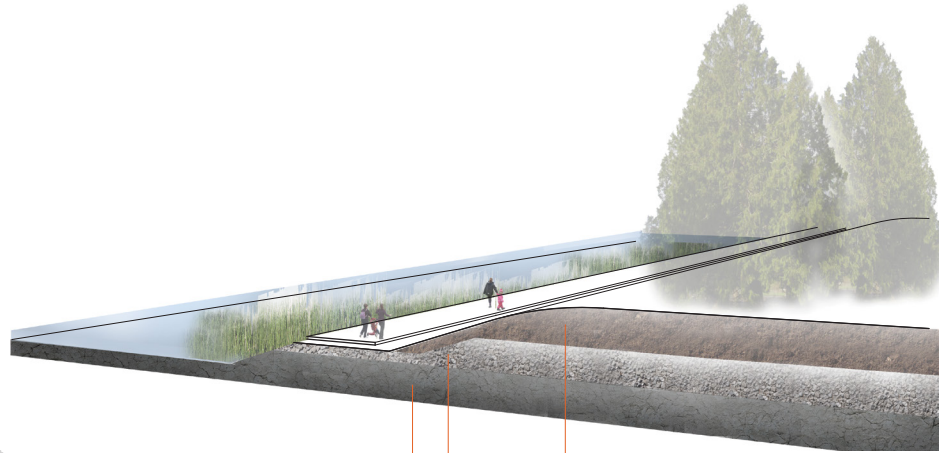

GROW

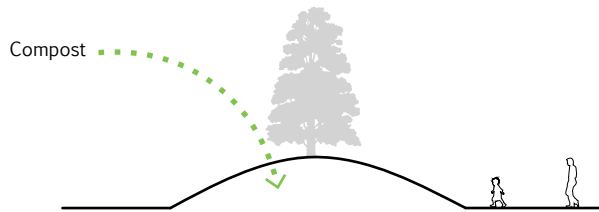

Figure 4.16 In the top diagram, “cut” space is used to hold and infiltrate water and fill material is prepared to become a growing medium. In the diagram below, the fill material provides drier, more stable conditions where larger wood can thrive.

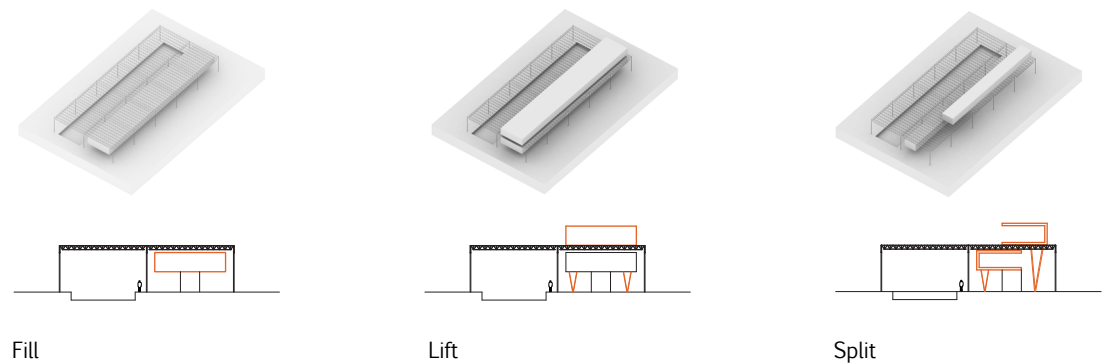
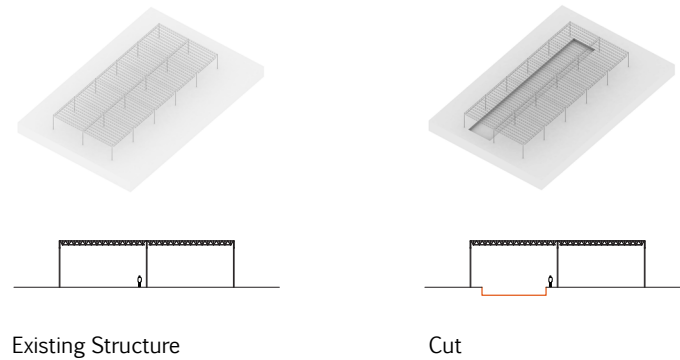

Figure 4.17 The architectural diagrams follow the same 'cut and fill' logic as the landscape diagrams. Cutting away from the concrete plinth and conceptually lifting it into the existing steel frame provides new programmatic opportunities. Adding cores to access the spaces makes the structure sound in terms of seismic.

In the architectural diagrams (figure 4.17), the strategy mirrors that of the landscape diagrams. The diagrams begin with the steel structure of the big box sitting on a concrete plinth and employ a cut and fill strategy to alter the big box. The concept is that lifting cut material into the steel frame permits 'collection' (public spaces) to occur in the void left by the cut. The 'fill' material is lifted and held within the steel frame, providing space for more private or controlled program. Splitting the excavated 'fill' material breaks down the scale of the structural bays (existing bays are roughly 50' square) and allows light and air to freely penetrate.

The key to making spaces such as the Fred Meyer 'something more,' is diversifying and mixing the overly simplistic design and retail formula.¹⁰ This project hypothesizes that, as the site becomes increasingly saturated, it makes less and less sense for Fred Meyer, or any other large retailer, to remain. Additionally, the development on top of the Black River is a scar that splits Renton apart. Therefore there is an opportunity for this site to be a public amenity that ties Renton together. The program for the ground floor of the proposal is mostly public, with a visitor's center, café, and shops. Semi-private program on the ground floor includes growing labs where students

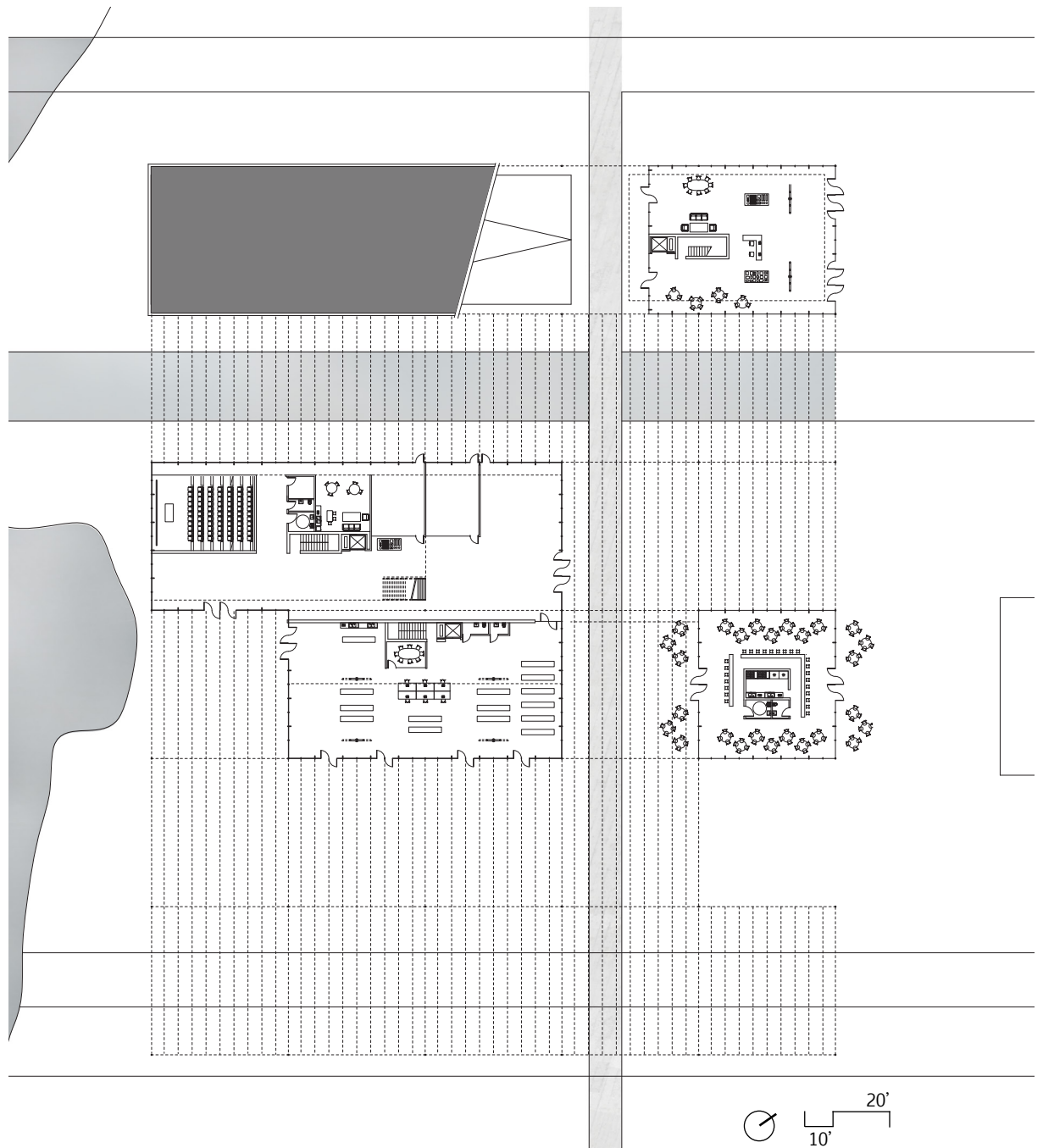

Figure 4.18 Proposed Ground Floor Plan

of urban agriculture could test the feasibility of different growing strategies on former big box sites. Part of the logic of the agricultural component is that prior to the Renton Shopping Center development the site was used for agriculture.

The ground floor plan (figure 4.18) is predominantly public, with a visitor's center,

lecture hall, restaurant and small shops. Visual permeability is prioritized on the ground floor where glass and steel are the most legible materials. Concrete cores help support the existing steel structure as well as the added levels of program. The remaining space at ground level is composed of office and lab spaces devoted to studying sites such as these

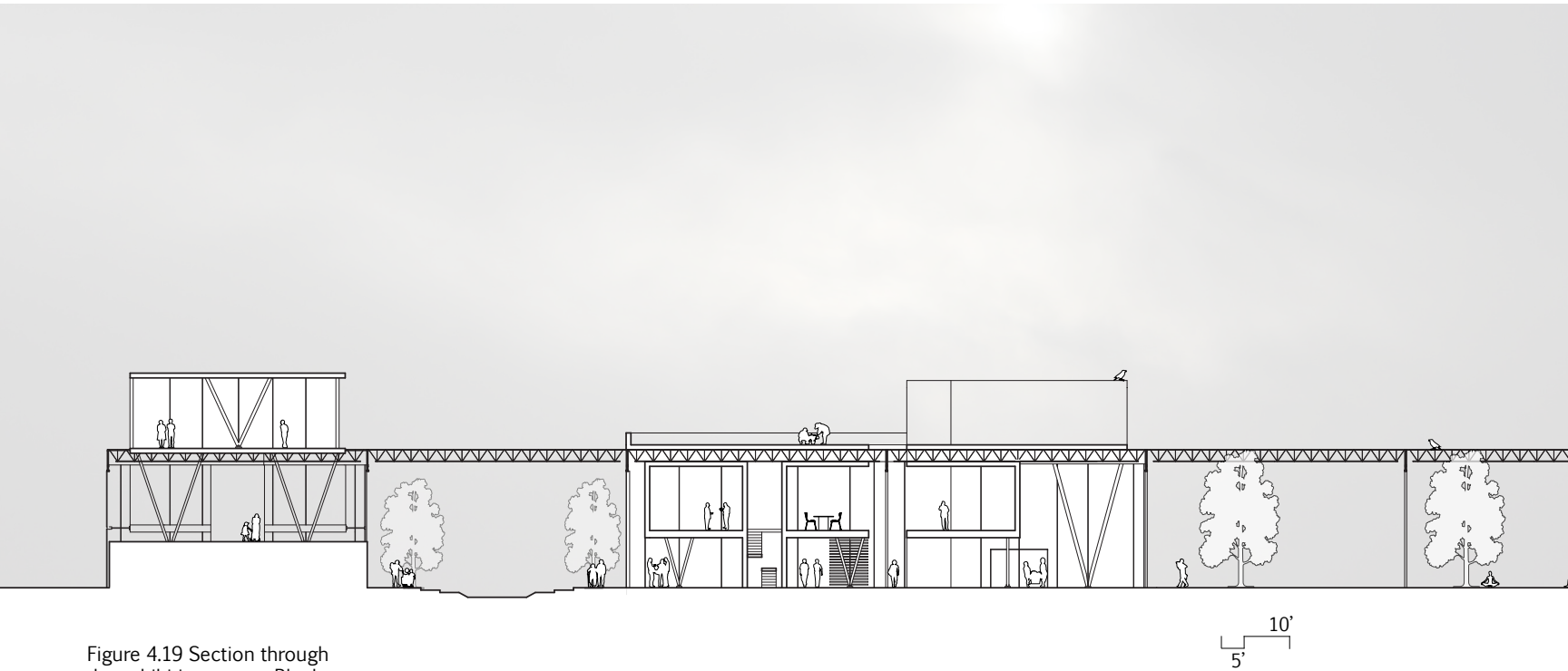
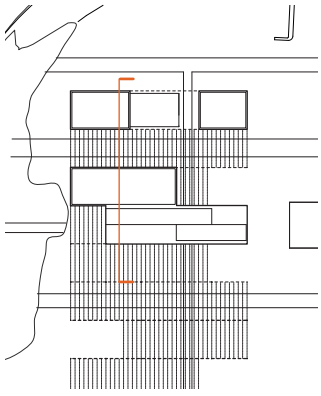

Figure 4.19 Section through the exhibition space, Black River Passage, shops and labs

and the opportunities they bear – in this case, primarily agricultural.

Sections through the building emphasize the new section of the site whereby variance creates opportunities. Where the ground remains level, it is devoted to public space, whether interior or exterior. Where there are depressions, as in the second bay of figure 4.19, saturation takes hold. Where the section swells or sits within or on the steel frame,

private program is organized. In figure 4.20 ‘fill’ material, recomposed to perform structurally, lifts the structure off the ground and connects the higher exhibition space with the visitor’s center. For this site, private program includes growing lab spaces, a Black River Exhibition space, and space for administrative purposes.

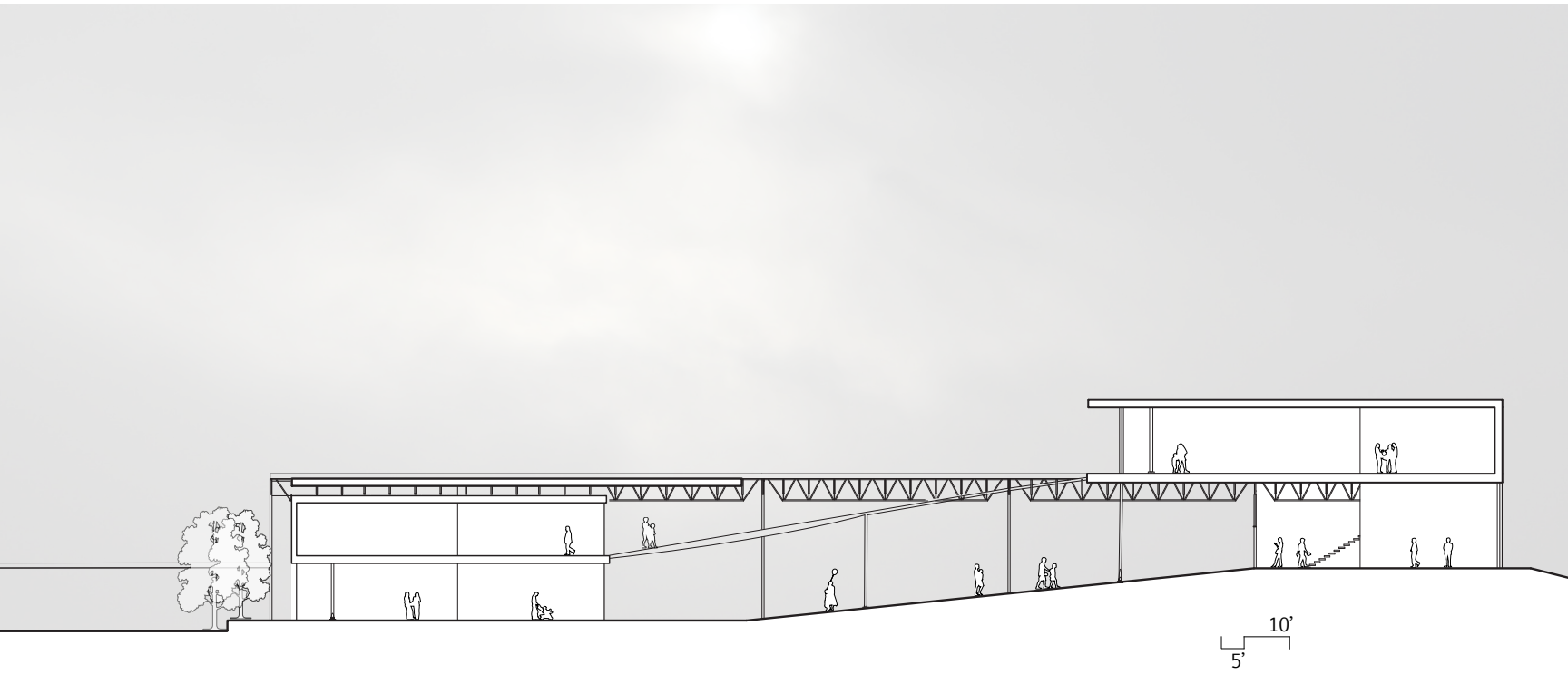
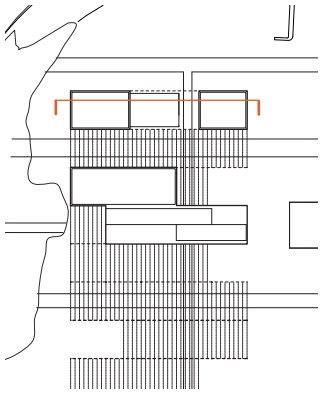

Figure 4.20 Section through the Visitor's Center on the left and the Exhibition Space on the right

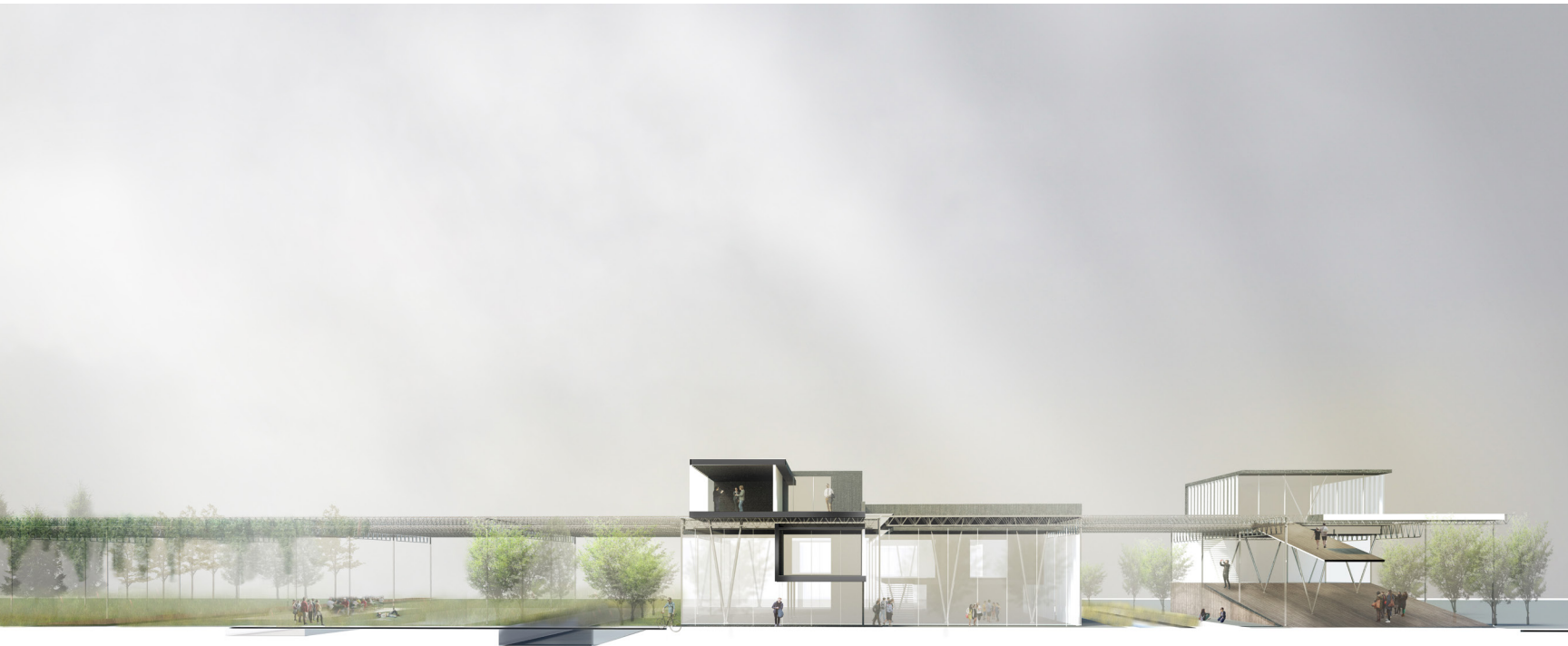
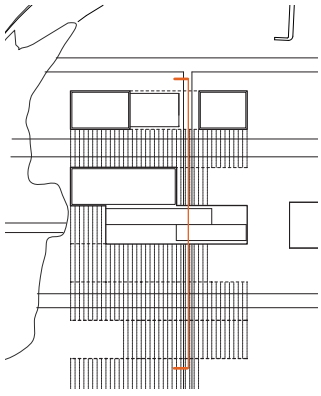

Figure 4.21 Section perspective showing the extent of the old Fred Meyer structure, with architectural program added on the right and landscape oriented space on the left

The long section through the old big box structure (figure 4.21), exhibits the tension between the built form of the new structure sitting within the old as well as the tension between landscape architecture and architecture, whereby one encroaches on and supports the other. Figure 4.22 depicts an unbuilt portion of the Fred Meyer structural bay where a hops and beer garden help attract the

community to the site. Figure 4.23 describes the scene in the café space, where the cut material forms program overhead, leaving the ground floor to be defined by the lighter steel frame. Figure 4.24, looks through the open bay between the exhibition space and the lecture hall, where the Black River is beginning to reclaim territory and make public space at the same time.



Figure 4.22 Perspective looking through an open bay in the steel structure repurposed to grow hops and be a summertime beer garden



Figure 4.23 Perspective in the cafe space

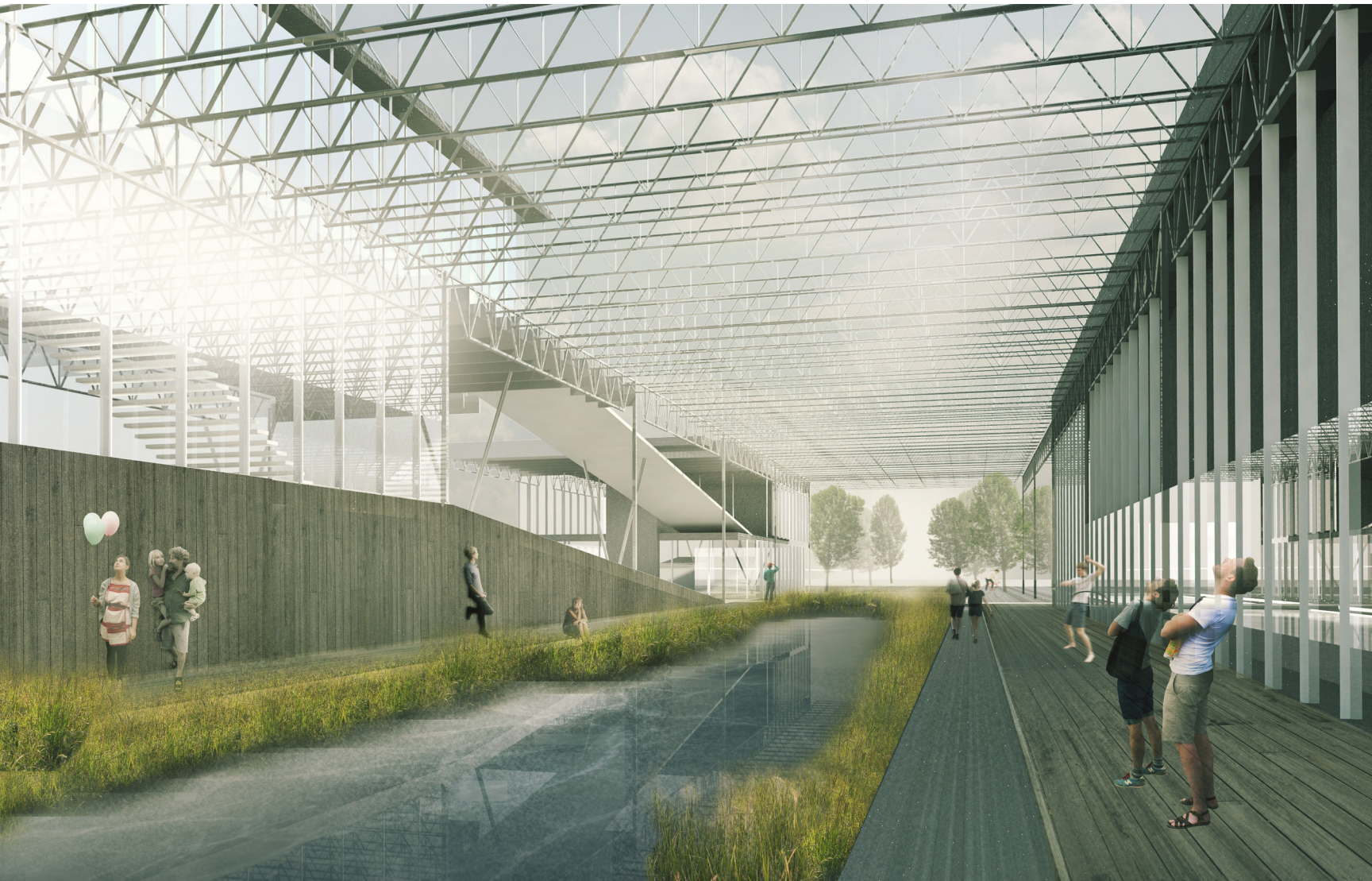

Figure 4.24 Perspective looking through the Black River Passage, with the Exhibition space on the left and lecture space and shops on the right

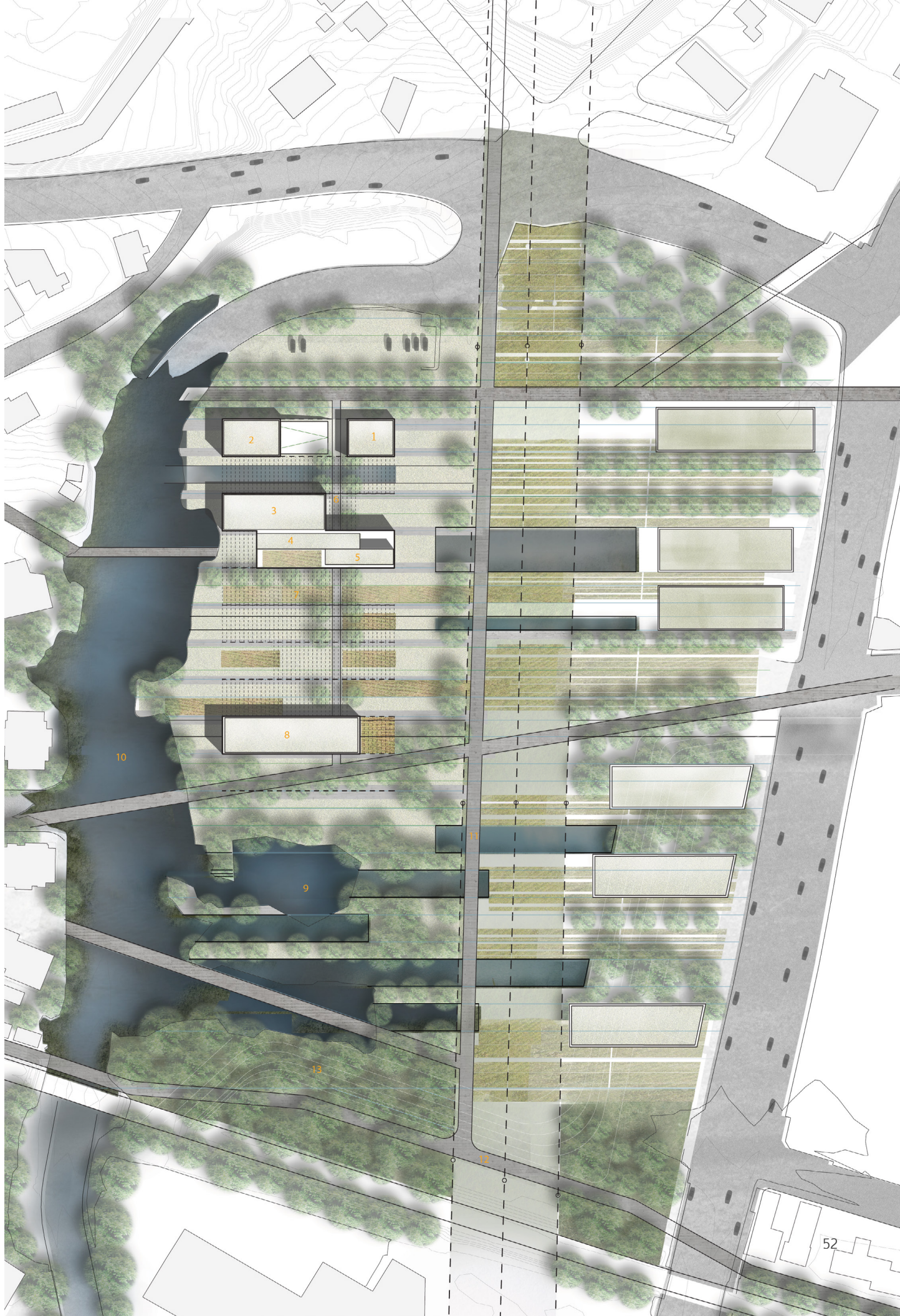
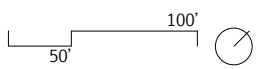

Figure 4.25 Proposed site plan



The evolving site plan (figure 4.25) is shown here in a state where the cuts in the landscape have begun to deteriorate and the organizational grid is now only tenuously present but entirely re-oriented to the site's public program. The east portion of the site is occupied by tenants of future capital interests, be it retail, data storage or otherwise. Connections from the site through and across Rainier Avenue are key in connecting to Renton's Downtown core. Several connections oriented to pedestrians and cyclists serve to connect those users and slow down the traffic on Rainier Avenue. As Renton grows as a city, and as manufacturing grows, it is possible that Rainier Avenue will be a more lightly used artery. Running north-south through the middle of the site, is the reclaimed territory of the power corridor. Since the space is unbuildable, there is an opportunity to link it with the water collection strategy of the site such that community gardens could thrive. Further north, in Seattle, Chief Sealth Trail runs

beneath power lines and a similar concept can be employed here. The western portion of the site shows the Black River having virtually taken over Hardie Avenue. Planned excavation of the site, in the form of the cuts into the grid, can lead to more natural excavation when water charts its own territory as the site becomes more saturated. As the site matures it will either need preservation against oncoming development or it will need to expand to accommodate an even larger amount of water from the region. In the case of preservation, the expanded uses of infrastructure will link the site to critical community assets that will help insulate the site from recklessly capitalistic development. In an alternate or concurrent model of expansion, the site could easily expand along the old course of the Black River. There is in fact a Walmart within a quarter mile as well as multiple auto-dealerships, all of which own acres of impermeable surface parking. A re-saturated Black River corridor could positively re-orient this dis-used part of

Renton and would be a critical ecological asset and failsafe should the 52-year old Howard Hanson Dam ever fail.

Endnotes

1. Weiss, Marion and Michael Manfredi. (2011). "Evolutionary Infrastructures," Harvard Graduate School of Design, Oct. 11. Lecture. http://www.youtube.com/watch?v=mJH_bLPKOAU
2. ftp://ftp.odot.state.or.us/techserv/Geo-Environmental/Hydraulics/Hydraulics%20Manual/Chapter_07/Chapter_07_appendix_F/CHAPTER_07_appendix_F.pdf
3. Berger, Alan. (2006). *Drosscape*. New York: Princeton Architectural Press, 53.
4. Varnelis, Kazys. (2005). "Centripetal City," *Cabinet Magazine*, Issue 17. <http://www.cabinetmagazine.org/issues/17/varnelis.php>
5. Christensen, Julie. (2008). *Big Box Reuse*. Cambridge, MA: MIT Press.
6. Rybczynski, Witold. (2010). *Makeshift Metropolis*. New York: Simon & Schuster, 103.
7. Bustillo, Miguel. "As Big Boxes Shrink, They Also Rethink." <http://online.wsj.com/news/articles/SB10001424052748704728004576176601936377760>
8. Christensen, Julie. (2008). *Big Box Reuse*. Cambridge, MA: MIT Press.
9. Howland, Jordan. "Lake to Sound Trail: Kit of Parts," <http://www.4culture.org/2013/10/lake-to-sound-trail-kit-of-parts>
10. Mattson, Kevin. (2002). "Antidotes to Sprawl," in *Sprawl and Public Space Redressing the Mall*, edited by David J. Smiley. New York: Princeton Architectural Press, 41.

CHAPTER 5: Reflections

This thesis hypothesizes that large-scale commercial sites, throughout the world, are well-positioned to be assets for cities and communities in the future. Big box retail re-use projects exist in many forms of architectural dialogue. The key to re-orienting such sites, however, is consideration of the land the big box structure occupies. Real solutions to the problems of the city and the suburb can only be achieved through understanding the place of each within a larger context.¹ The site of the Fred Meyer in Renton is only remarkable upon discovering its history, tangled with the Black River and infrastructure. In the time I spent working on this project, the idea of transgression recurred. The site of the Fred Meyer is very much a site of transgression, in that a series of transgressions lead to its current condition. The “cuts” in the landscape I propose are also transgressions against what is there. In terms of architecture and landscape architecture, transgression has to do with the boundaries of each. A transgression, by

definition, transcends or exceeds boundaries but in so doing does not deny them but completes them.² This is how I thought of the relationship between the landscape and the architecture of the site. A series of initial transgressions in the language of the landscape ultimately inform more than just the exterior surface. The architecture adopts but also withstands the landscape and its shifting hydrology. Water infiltrates the site where there is low-ground, while architecture and public spaces occupy local high-ground.

For the final review the conversation focused on the scale of the landscape. The reviewers were enthusiastic about the project but wanted to know how it could work financially – what happens to all of the lost retail space? The reviewers also commented that the narrative of the project may not need to be so focused on the river. The reality of the space at hand is that it is crossed by infrastructure and leftover in many ways. Such spaces exist in



Figure 5.1 Existing site organization, combining the logic of the parking lot and the Fred Meyer structural grid

cities everywhere, irrespective of a river. The question is, what characteristics of this site and proposal are suitable for sites that do not have a riparian history?

Working on a dual degree thesis has been an exhilarating and challenging process. In terms of square footage, this project is much more oriented toward ‘unbuilt’ space. However, ‘unbuilt’ should not be confused with landscape. The notion that landscape architecture has an ‘unbuilt’ quality is misleading because in fact ‘natural’ urban environments are very much constructed. Understanding this from the start, I developed a way of seeing the site such that the architecture and the landscape were almost indiscernible (see figure 5.1). From that point

of analysis, where a system of organization governs interior and exterior spaces, the design took shape in a way that could not possibly ignore or even prefer one discipline to the other.

Endnotes

1. Spirn, Anne Winston. (1984). ‘The Granite Garden: Urban Nature and Human Design,’ (excerpt reprinted in *On Landscape Urbanism*, Center 14, University of Texas at Austin School of Architecture 2007), 54.
2. Jenks, Chris. (2013). “Transgression: The Concept,” in *Architectural Design Magazine*, November, London: Wiley, pp. 20-24.

BIBLIOGRAPHY

- Bargmann, Julie. (2012). "New Architecture Faces the Future," in *Metropolis*, <http://archive.today/wRKV>
- Belanger, Pierre. (2013). "Landscape Infrastructure," in *Harvard Design Magazine*, No. 36. Cambridge, MA: Harvard University Graduate School of Design.
- Belanger, Pierre. (2012). "Landscape Infrastructure," Harvard Graduate School of Design, Mar. 24. Conference. <http://www.youtube.com/watch?v=BLQkslziVEY>
- Buerge, David. (1985). "The Life and Death of the Black River," in *The Weekly*, Oct. 16-22, Seattle.
- Bustillo, Migeul. (2011). "As Big Boxes Shrink, They Also Rethink," *The Wall Street Journal*. 3 March 2011. Web. 29 Sep. 2013. <http://online.wsj.com/news/articles/SB10001424052748704728004576176601936377760>
- Christensen, Julie. (2008). *Big Box Reuse*. Cambridge, MA: MIT Press.
- Cuff, Dana and Roger Sherman. (2011). *Fast-Forward Urbanism: Rethinking Architecture's Engagement with the City*. New York: Princeton Architectural Press.
- Czerniak, Julie. (2013). "Landscape's M.O." in *Formerly Urban*, edited by Julie Czerniak, New York: Princeton Architectural Press, 155.
- Frampton, Kenneth. (1995). "Toward an Urban Landscape," *Columbia Documents*. New York: Columbia UP.
- HistoryLink. http://www.historylink.org/index.cfm?DisplayPage=output.cfm&file_id=10221
- HistoryLink. http://www.historylink.org/index.cfm?DisplayPage=output.cfm&file_id=686
- HistoryLink. http://www.historylink.org/index.cfm?DisplayPage=output.cfm&file_id=3551
- Howland, Jordan. "Lake to Sound Trail: Kit of Parts," <http://www.4culture.org/2013/10/lake-to-sound-trail-kit-of-parts>
- Jenks, Chris. (2013). "Transgression: The Concept," in *Architectural Design Magazine*. November, London: Wiley, pp. 20-24.
- Mattson, Kevin. (2002). "Antidotes to Sprawl," in *Sprawl and Public Space Redressing the Mall*. Edited by David J. Smiley. New York: Princeton Architectural Press, 41.
- Moses, Joseph. (1989). In an interview with David M. Buerge from *Renton, Where the Water took Wing*. California: Windsor Publication.
- Nietzsche, Friedrich. (1983). *Untimely Meditations*. Trans. R.J. Hollingdale. Cambridge: Cambridge UP.
- Nora, Pierre. (1989). "Memory and History: Les Lieux de Memoire," in *Representations*, No. 26. University of California Press, p. 8.
- Petts, Geoffrey. (1990). "Forested River Corridors: A Lost Resource," in Denis Cosgrove and Geoffrey Petts (eds.) *Water, Engineering and Landscape*; New Delhi: CBS Publishers & Distributors.
- Petts, Geoffrey. (1990). "Water, engineering and landscape: development, protection, and restoration," in Denis Cosgrove and Geoffrey Petts (eds.) *Water, Engineering and Landscape*; New Delhi: CBS Publishers & Distributors.
- Rybczynski, Witold. (2010). *Makeshift Metropolis*. New York: Simon & Schuster, 103.
- Seewang, Laila. (2013). "Skeleton Forms: The Architecture of Infrastructure," in *Scenario Journal*, <http://scenariojournal.com/article/skeleton-forms-the-architecture-of-infrastructure>
- Spirn, Anne Winston. (1984). "The Granite Garden: Urban Nature and Human Design," (excerpt reprinted in *On Landscape Urbanism*, Center 14, University of Texas at Austin School of Architecture 2007).
- Varnelis, Kazys. (2005). "Centripetal City," *Cabinet Magazine*, Issue 17. <http://www.cabinetmagazine.org/issues/17/varnelis.php>
- Weiss, Marion and Michael Manfredi. (2011). "Evolutionary Infrastructures," Harvard Graduate School of Design, Oct. 11. Lecture. http://www.youtube.com/watch?v=mJH_bLPKOAU
- ftp://ftp.odot.state.or.us/techserv/Geo-Environmental/Hydraulics/Hydraulics%20Manual/Chapter_07/Chapter_07_appendix_F/CHAPTER_07_appendix_F.pdf

FIGURE CREDITS

All images created by author unless noted otherwise

- Figure B Google Earth, 2013
- Figure 2.1 Adapted by author from <http://rentonwa.gov/government/default.aspx?id=29887>
- Figure 2.2 http://riverhistory.ess.washington.edu/duw_puy/photo_1940/framedex.htm
- Figure 2.3 Adapted by author with images from Renton History Museum
- Figure 2.4 Renton History Museum
- Figure 2.5 Adapted by author from <http://www.kingcounty.gov/operations/GIS/GISData/Metadata.aspx>
- Figure 2.6 Adapted by author from <http://rentonwa.gov/government/default.aspx?id=29887>
- Figure 4.2 Ibid.
- Figure 4.3 Ibid.
- Figure 4.4 Ibid.
- Figure 4.7 Ibid.

APPENDIX

'BOX' GROUND

NEW 'BOX' GROUND

LOW GROUND

HIGH GROUND

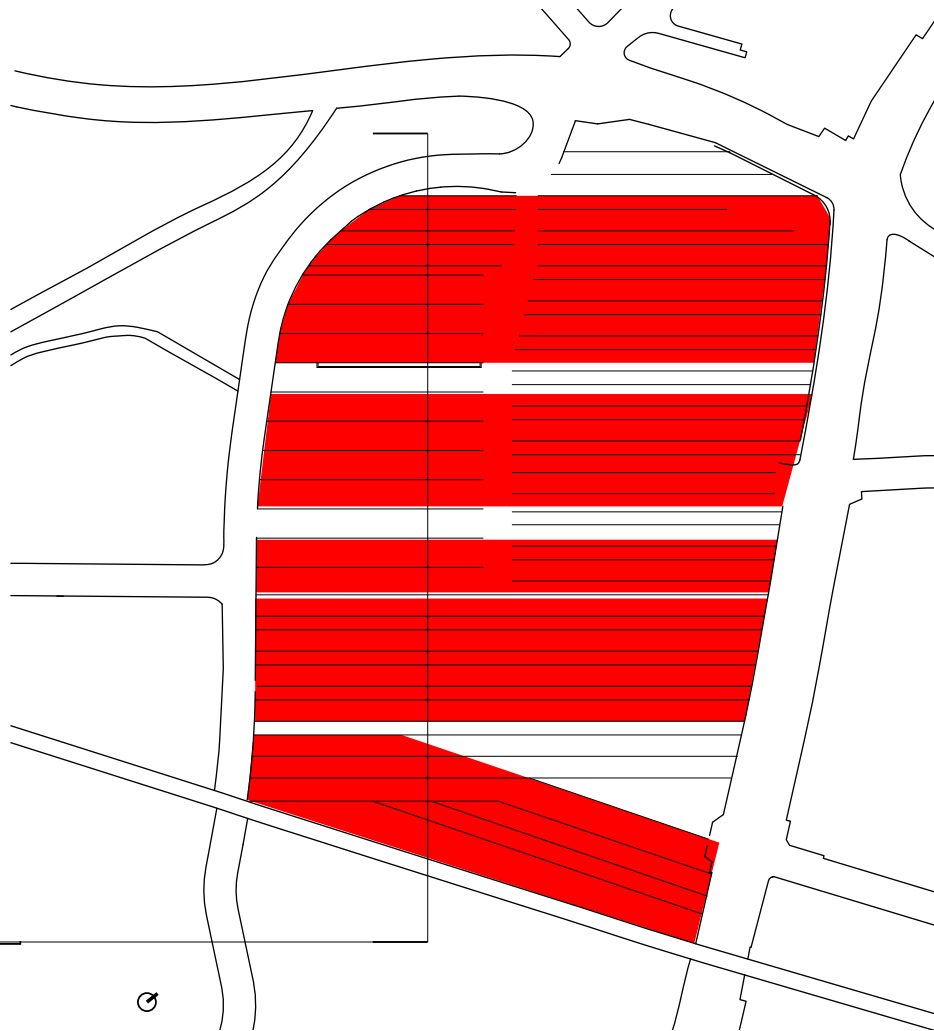



Thuja plicata



Picea sitchensis



Quercus garryana

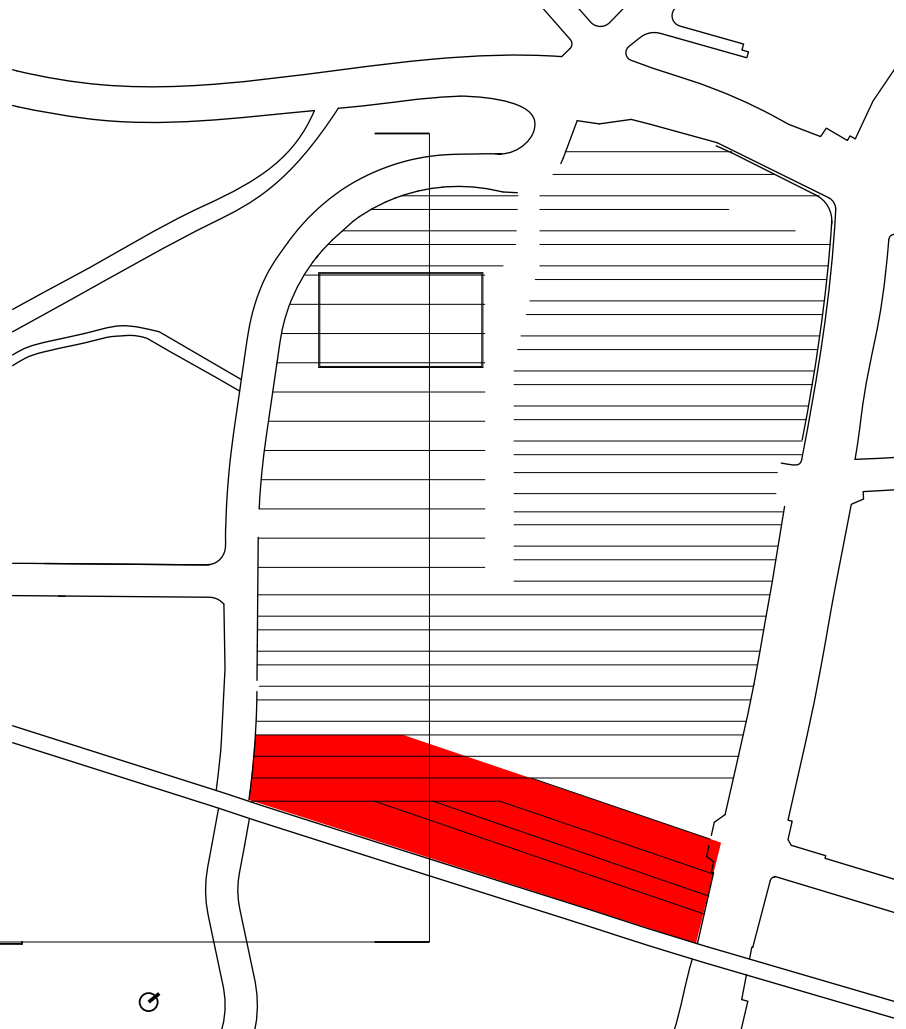



Cornus cericea



Salix viminalis



Carex obnupta

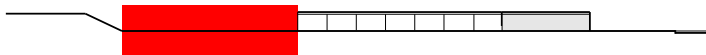
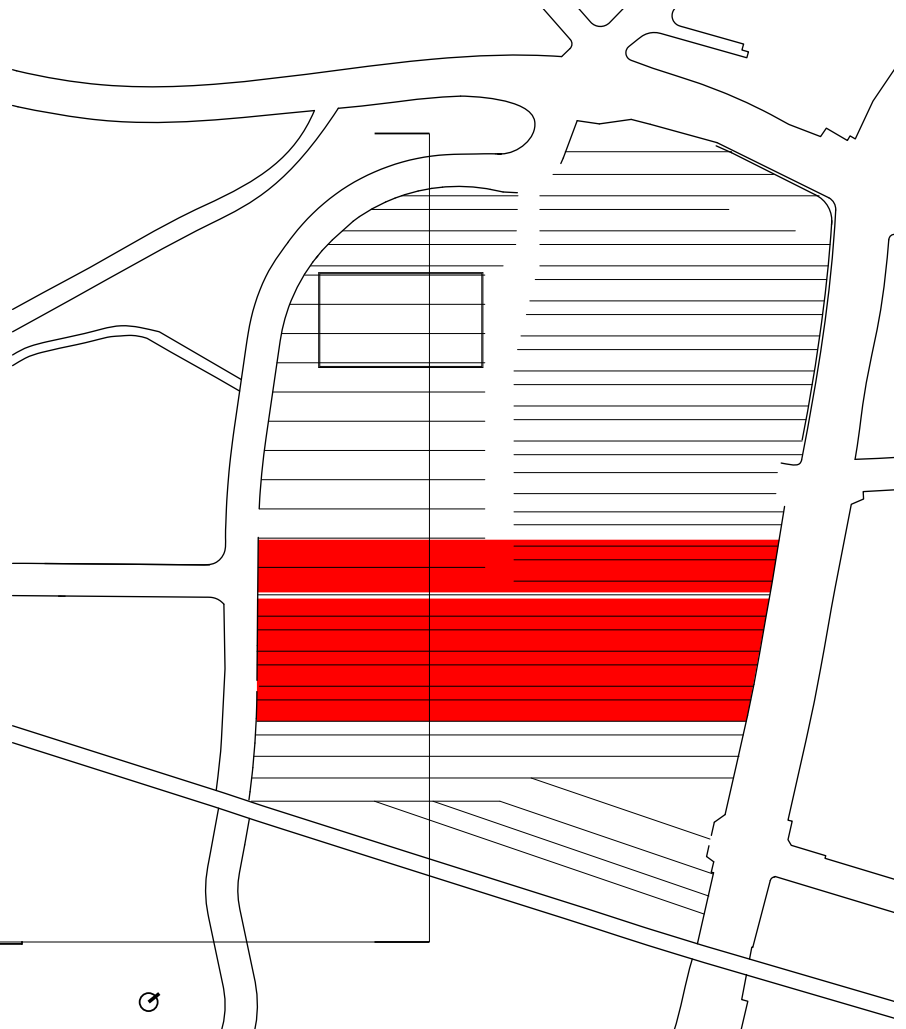



Humulus lupulus



Wisteria sinensis



Solanum lycopersicum

