

Insecurity and the Built Environment

The Science of Architectural Experience

Matthew R Seager

A thesis

submitted in partial fulfillment of the
requirements for the degree of

Master of Architecture

University of Washington

2018

Committee:

Vikram Prakash

Judith Heerwagen

Program Authorized to Offer Degree:

Architecture

©Copyright 2018

Matthew R Seager

University of Washington

Abstract

Insecurity and the Built Environment

The Science of Architectural Experience

Matthew R Seager

Chair of the Supervisory Committee:

Vikram Prakash

Architecture

As architects, we define our designs by both quality and performance. However, when it comes to experience, we often stick to what we know and how we can intuitively describe it. This theory and research thesis combines the sciences and humanities to get a closer understanding about how we, as human beings, psychologically and physiologically experience the built environment. Fundamental to this is the role that identity and culture play in our perceptions. We will discuss theories of architecture, philosophy and history from the late 19th century to present day and relate them to both the visual system and cognitive processing. We will lightly touch on topics of endocrinology, neuroscience and socio-cultural studies relating them to architecture and present-day social concerns. We will debate the role of identity and how the built environment is both a product and producer. Then finally, we will spend time discussing the tools and methods available to designers and our ethical responsibility to designing spaces within the global human context.



Insecurity and the Built Environment

the science of architectural experience

Matthew R Seager

committee
Vikram Prakash
Judith Heerwagen

architectural experience is...

melanopsin
oxytocin
not what you think
cortisol
norepinephrine

table of contents

i preface and acknowledgements

1 introduction

- 7 / architecture and the image
- 8 / identity
- 10 / ethics
- 13 / why science?
- 16 / overview

19 image

- 21 / direct experience in the theater of transactions
- 30 / representationalism and realism

33 perception and processes

- 38 / the visual system
- 44 / the limbic system and first impressions
- 50 / reward and anticipation
- 53 / knowing
- 58 / culture, cognition and consciousness

65 what can you do?

- 68 / it's already happening
- 71 / apply the science
- 72 / measurements
- 80 / design intelligence, reflexivity and whatever happened to criticality

91 closing remarks

98 back matter

- 98 / end notes
- 111 / bibliography

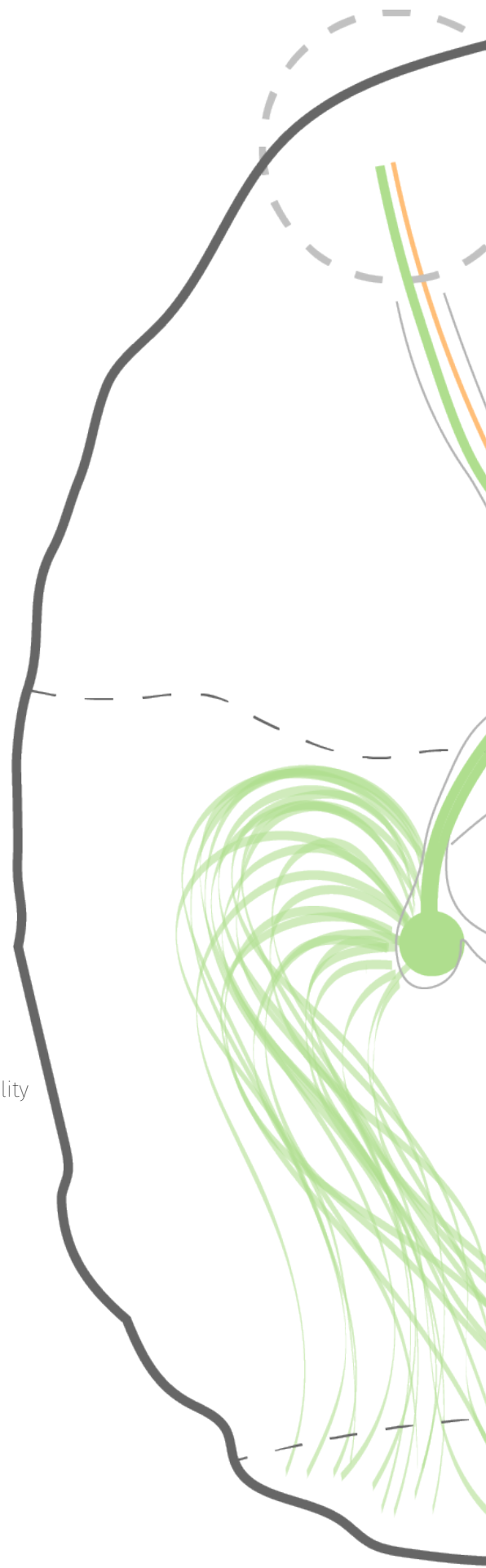

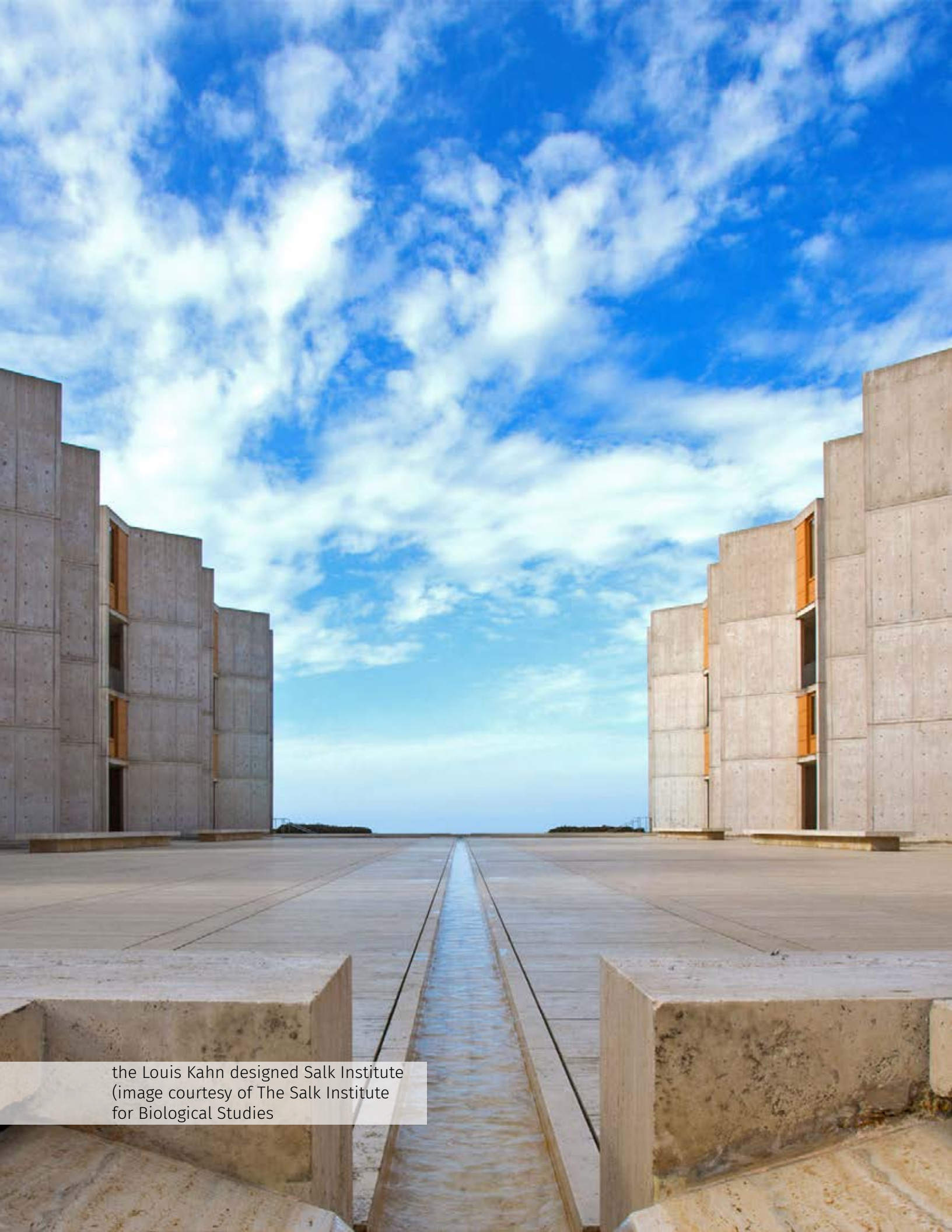

the Louis Kahn designed Salk Institute
(image courtesy of The Salk Institute
for Biological Studies)

preface and acknowledgements

My thoughts along these lines were encouraged by J. Robert Oppenheimer, Niels Bohr and Leo Szilard, veterans of the revolution in physics that transformed our lives. Could we bring biologists and humanists together in one place for the enhancement each could have upon the other and thereby further guide the course of human history? How long could we keep the epistemology of human experience apart without jeopardizing our future through failing to realize the importance science and human values have for each other?

-Jonas Salk on bringing together the sciences and humanities¹

The overarching goal with this thesis project was to provide insights into the world of science and how it can be applied to design research and methodology. As the culmination of my college career, I found it best to take my design intentions and better understand the core of their being. In this sense, the physical world. By providing reference to secondary sources, the hope is that readers will be encouraged to dive deeper into some of these topics and find ways to integrate them into design thinking. Each topic discussed here is worth its own career's worth of devotion and talent. Furthermore, science is an ever-growing knowledge base, constantly evolving and proving prior theories wrong. It is very possible that in a matter

of a century, this knowledge could be obsolete as new discoveries are made with new technologies and computing power. Despite common perception in public debate, science itself is a theory. However, it is a theory based on structured observation, critical analysis and peer review that is used to challenge further understanding of our world and our capabilities.

It is up to the reader to take responsibility of constantly educating themselves and further challenging the knowledge of both themselves and their contemporaries. I'm merely providing a snapshot in time of viewpoints from the fields of philosophy, architectural theory and various sciences to make connections to the design process and show how they are either being applied currently or can be applied in future exploits. In the 21st century, designers should devote themselves to staying current in research both within and outside of their field. The term *interdisciplinary* is becoming commonplace within the profession and, like previous terms such as *corporate social responsibility* and *sustainability*, face the danger of being reduced to mere marketing buzzwords. Another buzzword, *integrity*, has become our main weapon for ethical practice and there is no better way to justify your design intentions than through measurable means. I hope this paper encourages designers to read scientific studies, develop scientific methods and work with those in other professions to enrich the built environment around us.

With that being said, I'd like to acknowledge the tremendous amount inspiration many in my career have provided me with. This list is too long for me to attain approval by all of them to include here, although many are deserving. I'll just say thank you to the faculty at the University of Texas Arlington, where I completed my undergraduate degree in architecture. They helped me take my passion for art, history, philosophy and politics and fashion it into design of built form. Also, the faculty at the University of Washington for taking it much

further, especially in the realms of history and theory. It is my time in Seattle that made the largest impact in my education career. Additionally, I can't fail to mention my family for all their support.

Last, and especially not least, I'd like to acknowledge the efforts of my committee members, Vikram Prakash and Judith Heerwagen. Their efforts, criticisms, insights and inspiration over the last nine months have fundamentally shaped not just this work, but my career going forward. I specifically selected Vikram and Judith to help embody the bridge between humanities and science. With their experience ranging from philosophy, fashion, architecture and art to psychology, building performance and scientific research, their leadership encourages me to further develop these fields with in my own practice.

Thank you so much.



from the Daniel Libeskind designed
Jewish Center in Berlin
(image by self)

introduction

While we have relied principally on the quantitative and controlled frameworks of physics and geometry to define and manage the seemingly incomprehensible, the qualitative and approximate world of biology is now emerging as a more useful model of both scientific and metaphysic explanation.

-Thom Mayne, Combinatory Urbanism¹

Architecture has always been a hybrid practice of problem solving. What is most understood though, is that architecture is the art of building. We are given a problem and we find a solution. It is a practice that builds on the ideas that come before it, whether it is criticizing a prior movement or political motivations within a given context; designers turn built form into a symbol. The message is one that is produced spatially or iconographically, either way it conveys some meaning. Even the least intentioned architect will have meaning thrust upon their work by observers and occupants. For this reason, the humanities will never be removed from the art of designing the built environment. What changes throughout time are the methods and tools we use for solving problems.

The designers mind is one of technical and artistic expertise and we've developed the ability to use specific language for each. For most of human history, art has been described in poetic, intuitive or emotive terms. As we define ourselves experts of the built condition, we can't ignore that these words are more subjective than most. As professionals, we also understand that these words are highly persuasive. The artist sells their work by appealing to the emotions of the viewer, speaking to the intuitive and sensual side of the spectator. However, society has changed, and our needs have as well. As soon as modernism settled in, designers sought to approach problems with more rationale and less metaphor. Rationalism, minimalism, cubism and expressionism were focused on method and analytical abstractions of experience. Through the 20th century, a single generation went from horse-drawn carriages to airplanes. Within the lifetime of Frank Lloyd Wright, the world went from the invention of the telephone to launching satellites in space. In the same century, psychology went from its early stages of experimenting on head trauma victims of war to functional magnetic resonance imaging that can capture images of brain activity. Humans have developed nuclear energy, visited the moon and mapped the human genome. We have eradicated diseases and created robots with far more computing power than the human brain.

After all this advancement, a large amount of architecture firms are resistant to adopting new technologies. A surprising amount are resistant to 3d modeling programs and building information modeling. Architecture is a very conservative profession. It may be due to budget constraints, long timelines for design and construction, politics or pedagogical nepotism. Regardless, we are generally hesitant at adopting new ways of practice. What is even more profound is the way we speak of experience. In 1989, the first internet service provider released the world wide web to the public.² Since then, web and app developer companies practice what is called *user experience (UX) design and research*. As a practice, it has been

around for decades in product design and engineering. For modern designers, this process involves qualitative and quantitative analysis of user behavior and needs, involving numerous parameters from fields such as ethnography, anthropology and psychology. Practices include eye-tracking, surveys, interface analytics that track movement of individuals in digital space and other empirical data that help understand human behavior within a designed environment.³ The common method of describing user experience in architecture is metaphorical and ethereal. We describe architecture as if it touched our “soul” and embodied heavenly qualities when in reality, science has well documented theories of how humans respond to environments and developed numerous psychological theories to accompany neurobiological and endocrinological discoveries. In his 1994 book *The Poetics of Space*, Gaston Bachelard provides us the following quote:

*A philosopher who has evolved his entire thinking from the fundamental themes of the philosophy of science, and followed the main line of the active, growing rationalism of contemporary science as closely as he could, must forget his learning and break with all his habits of philosophical research, if he wants to study the problems posed by the poetic imagination.*⁴

Bachelard declares the need to break from rationale and knowledge of science to truly speak of poetics and human experience. When discussing poetics “the cultural past doesn’t count.”⁵ There is something in the very moment an image appears that can only be explained by the “inner light” known as the *phenomenology of the soul*. It is through this that the painting, which is derived from the mind, rejoins the “obligations of the world of perception.” To understand Georges Rouault’s painting, one must “participate in an inner light which is not a reflection of a light from the outside world.”⁶ It is exactly this that I intend to confront. Bachelard believes there are two phenomenological relationships to the outside world: that of

the mind and that of the soul. I'm not intending to challenge the poetic nature of our experiences for this is a quality perceived and justly desired. What is at question is the origin of our experiences, how we experience them and what does neuroscience tell us about what we desire from the built environment?

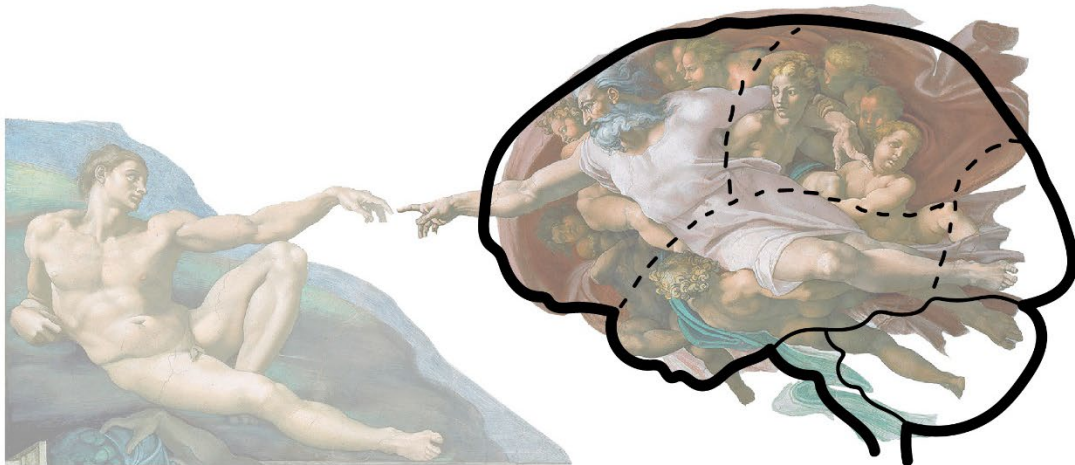

Figure 3: Frank Lynn Meshberger published an article in 1990 analyzing Michelangelo's Creation of Adam and showing the form encompassing God is shaped remarkably like a brain. This began discussions on whether the artist had an advanced understanding of the brain and its roles in human life.⁷

Humans have always struggled with how they interface with the world and how phenomena can be described. It was the pre-Socratics and Democritus that first engaged the idea of atoms. To him the universe was made up of atoms and voids.⁸ Plato addressed phenomenology and epistemology with his *Allegory of the Cave*. To him, the world we perceived was not the world of truth. Truth was something mortals could attain only through combined effort and intelligence.⁹ Philosophers from then on have continually engaged in an ongoing discourse of objects and how we relate to them. It wasn't until the nineteenth century

that psychology became a field of study. Despite the Aristotelian belief that the mind was not outside the body, it wasn't until modern science that the brain was given its full due.¹⁰ In 1879, Wilhelm Wundt performed what is known as the first psychological experiment. He created an apparatus that measured the time it took for an observer to hear a ball hit and press a telegraph key.¹¹ This begins the age of empirical analysis of how the brain perceives and responds to its environment and the launch of psychology as a science.

Architecture never embraced the full potential of this development. To further the problem, an astonishing amount of our built environment is constructed without the use of architects, meaning the spaces that construct our world have mostly been designed by those only trained in construction and real-estate development. Most people don't feel the need to hire architects to design spaces. Architects haven't done their profession enough justice by educating the public and maintaining up to date discourse with the science community. We operate predominately in the realm of art, despite seeing a widespread disregard for creativity and expression. We often proclaim our spaces make life better experienced, more productive, and comforting while seldom investigating the systems by which those are experienced.

Designers field of comfort is the humanities. Architecture does require applied sciences such as engineering. Modernism created a breed of designers imposing themselves onto social sciences seeking to solve the worlds ills through an increasingly machine-like approach to the built environment. We have now built tools for parametric modelling and data analysis based on algorithmic coding and formal sciences (computer science and mathematics). And finally, our approach to natural sciences is growing with more research being done with materials, sustainability, workplace efficiency, lighting analysis, healthcare spaces, and biophilia. The call for interdisciplinary studies increasing with more integrated design processes and tools at our

disposal; it is time we dissolved these boundaries in which we operate, apply ourselves to the world we seek to better and take steps in understanding our client, the human body.

My approach here will not be a direct plunge into neuroscience because I don't believe that will translate productively to most designers. We must operate in terms we understand with the tools we know to use, including those of theory and the humanities. This only enriches the ability for science to meet the aesthetic desires of people. Theodore Adorno once spoke during a critique of functionalism that architecture must demand a constant aesthetic reflection. He realized the functional purpose of art and aesthetics, the desire of humankind for expression.¹² This aesthetic reflection can't ignore the advancements in neuroscience regarding our needs and experiences but must not turn its back on our theoretical nature.

/ architecture and the image

In this paper we will be using the word image a lot, so it may be prudent to understand better what we mean by it. As we will use it, an image refers to a constructed perception that is the product of some stimuli and cognitive processes. This includes scenes, forms, spaces, culture, and the self as image. The idea of image is essential to how we will talk about identity and visual perception in the world. The use of the word is historically transdisciplinary and can describe qualities present in the world and ourselves. Images can be both conscious and non-conscious, real and imaginary, historical and futuristic.

This will be fundamental when speaking of context, as context dictates the image. We will speak of Walter Benjamin and his essay “The Work of Art in the Age of Mechanical Reproduction” where he speaks of both audio and visual images being recontextualized by modes of reproduction and distribution.¹³ In his book *The Anaesthetics of Architecture* author and theorist Neil Leach uses the word image to describe the visual experience and meaning of architecture and urban environments.¹⁴ In the book *Visual Memory*, multiple authors use terms such as image and *imagistic* to define processes and mental constructions of visual scenes.¹⁵ Even the word imagine, which is essential to designing, stems from the Latin word *imago* which means “an image.”¹⁶ Jacques Lacan uses this word to describe the transition from the nascent infant into a self-aware being.¹⁷ The word image has importance in many of the theories we will discuss in this work and thus from here on out, we should be clear how it applies to the subject matter.

/ identity

Next to image, identity is the most important term of this work and potentially the broadest term going to be defined. I’m aspiring to evince how and why both the function of identification and the role of identity are articulated neurologically and why this is fundamental to our experience of the built environment. Although we will discuss identity as self-image, we are not limiting the definition of identity to that of social contexts. It is about understanding and articulating, survival and expression, fear and pleasure, discourse and discrimination. Identity will be the broad term used to describe a myriad of other terms, but it essentially comes down to an act of differentiation and discrimination. The word identity

stems from the Latin *idem* meaning “the same.”¹⁸ I’m not here to join the debate of whether identity is defined by *sameness* or *difference* or any other argument on the linguistic definition of identity. For simplicity, we are to understand the process of identification is established by understanding and establishing a threshold of difference. This process, as an *act of measurement* (to be explained later), defines a tolerance of difference and a threshold of discrimination (discrimination as the recognition of difference, not the social connotations of discrimination). Our subconscious brain handles most of the workload in perceptively instantaneous calculations of how objects relate to the self.

The self is another term we must address for clarity given its rich discourse. To Freud, that which constructs the *self* consists of the *id*, *ego*, and *super-ego*. The *id* is the unconscious personality that operates on primitive functions, predominantly the *pleasure principle* where one seeks to either reduce pain or incite pleasure. The *super-ego* is the superior self that formulates the conscience based on learned and established ideals. The *ego* functions as mediator between the two and operates on the *reality principle*, where one decides what realistically will provide the most benefit.^{19 20} Lacan believed the *true self* was unattainable after the *mirror stage*. Following transition from the nascent self into the linguistic self, the post-mirror stage identity only exists as *imago*, the image a subject assumes. Upon realizing one’s self in the mirror, one establishes an exterior identity and therefore formulates and *ideal-I* that constantly motivates and elicits constant change.²¹ These theories speak to the motivational self through identification and gradients of consciousness and conscience. Understanding the non-conscious and conscious natures of identification is important to understanding the neuro-behavioral importance of identity. Two terms to relate here are *self-schema* and *self-representation*. The former is the “unconscious as well as systematized generalizations about the self.” The latter refers to “conscious and communicative

expressions.”²² Here we see an important divide between the unconscious and conscious identities. *Self-schema* encompasses Lacan’s *ideal-I* and what you could say the bulk of Freud’s *id* and *super-ego*. These activities, as will be elaborated on more later, are outside our conscious functions and substantially constitute how we perceive our world.

/ ethics

Anytime you start debating the role of identity, ethics isn’t far behind. In fact, identity is at the heart of many social battles present today. We currently live in a time where lines between ethnicity, gender and sexual orientation are being dissolved and anonymity is bringing about new freedoms for oppressed minorities. Culture wars are taking place over monuments that represent different values for different groups. National identities are being targeted and scapegoated in terrifying ways. The ethics involving identity are at the center of many pressing concerns in today’s world. In the architecture community, this touches on two fronts: workplace diversity and design aesthetics. The first refers to unfair treatment of minorities in the workplace, including pay disparity, and gender pay gaps. The latter refers to strategic use of stylistic representation, whether it is globalist, regionalist, or representative of other cultures. Although we are primarily concerned with the latter in this writing, it is not intended to downplay the significant importance that should be put towards building diversity and equality in the architecture industry. There will be later talk of diversity and the irrefutable benefits of the bringing together of different minds but for now, we will be focused more on identity as portrayed through architectural aesthetics.

Before going any further, we must explain the ethical framework that will be fundamental to the ideas shared in this work and should be kept in mind while evaluating past and future practice. Over the past few decades, developments in philosophy and *science studies* (interdisciplinary studies of science within social, historical, and philosophical frameworks) have brought about a wave of post-humanist thought. Now, I understand a study of architecture and the human brain doesn't sound great in relation to post-humanism but bear with me momentarily here. Post-human doesn't mean anti-human. It does not mean to negate the presence or importance of human agency in the world. It seeks to understand the role, process and presence of human agency in the world. The term derives from humanist thought and therefore becomes post-humanist. Humanism began during the Greek and Roman times with an emphasis and establishing and developing human capability in the world. This belief rested on a firm understanding of humankind, divinity, and the natural world. Humanism resurfaced in the Renaissance and became a major tenant in western thought. This broke the metaphorical shackles of religion over humankind in our creative and intellectual exploits, facilitating an emphasis on anthropocentric understanding. Essential to New Materialist critique is Cartesian and Newtonian duality. Cartesian human-nonhuman duality is broken down through analysis and relocation of the human within the framework of materiality. Newtonian duality is one of subject-object observational relations that lead to empirical explanations of the natural world through limited observation and analysis. This doesn't mean the equations and theories that explain physics are necessarily incorrect as many of them influence sciences and what we do daily. What this entails is that these "laws" are subject to a level of correctness, that they are not absolute but mostly accurate. Karen Barad refers to observation in classical Newtonian physics as "geometric optics" that uses "approximation schemes" to best understand behavior in the natural world. In relation, quantum physics uses "physical optics" to be formalisms that account for all phenomena and

apply at multiple scales.²³ This thought movement has altered the landscape on all fronts and has begun to engage thinkers to expand their boundaries and methods while encouraging ethical understandings and importance of interdisciplinary open thought.^{24 25 26}

Of first importance to this paper is Barad's *intra-action*, *agential realism* and the *apparatus*. These terms represent the way in which interface with the natural world, and therefore fundamental to how the brain functions within the world. Barad's apparatus is a material assemblage used to perform an "act of measurement" on the material world. In discussing Neil Bohr's critical examination of measurement processes Barad writes "measurement is a meeting of the 'natural' and the 'social.'"²⁷ As she puts it, "it is an instance where matter and meaning meet in a very literal sense."²⁸ This does not name any specific limited type of apparatus but applies to any material assemblage that performs this task. We must come to think of the brain as an apparatus. The first and most important reason is that the brain is *of* the material world. It is an assemblage of molecules constituting matter, manipulating and transferring energy through chemical and electromagnetic *intra-actions*. *Intra-actions* (as opposed to interactions) requires a flattening of the subject-object binary. Interaction requires separate, distinctly existing entities with distinct agencies whereas *intra-action* is "the mutual constitution of entangled agencies" that do not have preceding distinct agencies. Instead, they emerge through their *intra-action*. The brain is not a separate stand-alone entity in the physical world, but a functioning agent defined by *intra-action*. These concepts help define Barad's *agential realism* where humans are material bodies that aren't *within* a material world, but *of* the material world.²⁹

The brain then becomes an apparatus that performs an *act of measurement*. According to Barad, the act of measurement is a boundary making process. According to quantum

mechanics, to observe one must interact and alter the material world, easiest put one must set up parameters that allow them to see what it is that they are looking for. Our brain is set up in ways that allow it to perceive certain qualities in the material world. Just as an example, we can't see with our eye all ranges of light or, with our ears we can't hear all frequencies of sound. Therefore, the information processed through the brain is only what we are materially capable of perceiving. Our brain from a functional stand point then has constructed boundaries of perception, boundaries meaning there are qualities/entities included and consequently those that are excluded. One final example with an architectural implication, vibrations and deflection in floor slabs we can't perceive through our body can affect the performance of medical imaging equipment and affect patient health. It is important to understand the abilities of our apparatus and that which is excluded to best understand our design agency in the natural world.

/ why science?

The quote at the beginning of the chapter speaks to the importance science provides to metaphysical explanations. For many years the ethereal justifications of design have failed to capture really what it means to experience space. Science is the best field for describing what it means to be human. Although some holes still exist in the explanation of experience, we have a quite developed understanding of the chemical interactions in the brain and associated locations for activities and memories. We've accepted science to ventilate our buildings, keep them upright, move water and electricity, and provide proper lighting for neonatal development and workplace efficiency. We've used physics to calculate air

penetration and created adhesives, membranes, performative glazing materials and turn solar energy into usable electricity. Its hard to not believe, given the computing power available and large amounts of data, that architectural designers can't better describe the effects of aesthetics and form on the human body. It should come as no surprise, but these efforts are being made across the globe at research organizations and leading firms.

Studies in understanding how we identify objects and how we identify with objects formulate a new and more informed understanding of experiential architecture and its performance in our daily lives. This performative agency requires the establishment of a material self in a world of material objects. The world that impacts us is a bonding of matter that facilitates neuronal action, which in turn creates a material reaction. Somewhere in this process is what we understand as our self, both individual and collective. In this process, we have curated passages through our brain that recollect imagery for our needs of comfort and safety. Our material processes formulate our response to anxiety and resolve our insecurity. Architecture does far more than resolve our insecurity of physical shelter. Architecture is not a mere exoskeleton, it protects our neurological faculties as well. It protects it through varying controls of stress that impact reward, anticipation, motivation and reconciliation. Through the boundary making processes of differentiation and discrimination, the brain formulates the image of the world that we in-turn translate into the image of our self, the formalist *imago* that gets justified through the materialist world. Mimesis as *modus operandi* and identity as mantra construct our context. We both assimilate and accommodate to fit best balance pleasure and pain in our environments.

Theory and science do not belong in separate fields. As Jonas Salk believed and the Academy of Neuroscience for Architecture reiterates, the sciences and humanities need not be



from the Daniel Libeskind designed
Kö-Bogen in Düsseldorf
(image by self)

separated. The two advance each other. It is through theory that we articulate our thoughts and observations with linguistic understandings, symbols and metaphors that transcend boundaries of discipline. These theories are products of the mind, a mind that is under constant evaluation via *functional magnetic resonance imaging* (fMRI), microscope, psychology and philosophy. These boundaries must exist but as Barad exclaims, a responsibility is owed to that which is excluded. It is often in what is excluded from our standard point of view that provides the more enriched solution. An architect who understands structural and mechanical engineering has long been admired. It is time architects who understand the engineering of nature and biology find more presence in the field. Barad uses quantum mechanics not as metaphor but as a framework that jumps scales. It is not in the poetics of metaphor that the world materializes, but in the processes of becoming. Poetics can describe our experience and emotion while enlightening our understanding of space; however, science can describe space without rhetoric and with deeper awareness of causality and results. Through the process of correlating studies and mapping functionality, we can learn how, who and why we are, better justifying the design decisions we make.

/ overview

The following chapters provide commentary, criticism and share insights into the science of architectural experience. There are a few overall goals of this work. First is to provide references to scientific studies and theories that will open eyes towards the potential other disciplines, especially those in the sciences, can provide architects to better understand their clientele. Second is to provide a better understanding of how culture functions as a

mechanism of security, how it is manipulatable and how material objects such as architectural form and icon can be used to exploit and subject populations. This will be done through the lenses of architectural theory, psychology, endocrinology and neuroscience. Third, I hope to show many methods currently available and in practice that provide applications of scientific methods to the design process and discuss why we should practice in such a way. And finally, I will argue the ethical reasons why design practice should evolve in the face of conservatism and combat stagnation.

Chapter 2 will focus on the term image as mentioned in the previous section. It'll discuss theories on architectural image and scenic quality. In this section we will cover topics from Walter Benjamin, Guy Debord, Robert Venturi and Neil Leach. That'll be followed by a discussion of self-image and psychological concepts on image forming and the non-conscious. This topic specifically will discuss much of Neil Leach's book *Camouflage*. The chapter will then close with a section on representationalism and realism.

Chapter 3 will cover the process of visual perception from the point light hits the retina to the moment behavior is elicited. Here we will introduce key terms in understanding how the brain processes stimuli and the responses it produces within the system from hormones to memory. The visual system will be covered as well as the limbic system and association cortices. Then we will cover identity in depth regarding its embodiment in human form and how it relates to culture. We will discuss sociology and psychology theories that pertain to how we see ourselves and how aesthetics is both a product and a producer of identity. More discussion regarding culture, specifically on the weaponization of form and meaning caused by reinforcing and re-contextualizing identity. This chapter will close with a discussion on consciousness and recent related theories.

Chapter 4 will answer the question of what to do going forward. It'll cover practices by current architectural firms and studies by university researchers. We'll discuss technologies and equipment that can be used to better understand architectural experience and predict user needs. We'll cover previous studies and how performative measures can be derived and acted upon. And finally, I'll make a case for an abandonment of *critical regionalism* and an adoption of a more global tendencies that foster meaningful experience and diversity in the built environment.

The final chapter will tie everything together in an ethical statement and provide closing remarks. We will review the previously stated goals and ensure there is a clear path forward for designers to develop meaningful progress for the pressing social and environmental challenges ahead. Architecture is at a pivotal point. Thom Mayne said, "developments in life sciences, ecology, mathematics, systems theory, and computation have, over the last several decades, effected a *paradigm shift* in how we conceive of organizational processes."³⁰ The rate of developmental change brought upon us by the information age has the ability to render the architectural profession obsolete if it fails to solve pressing problems and provide experiences that enrich our lives. Better understanding the human body is fundamental to understanding how to better design for people in a changing world.

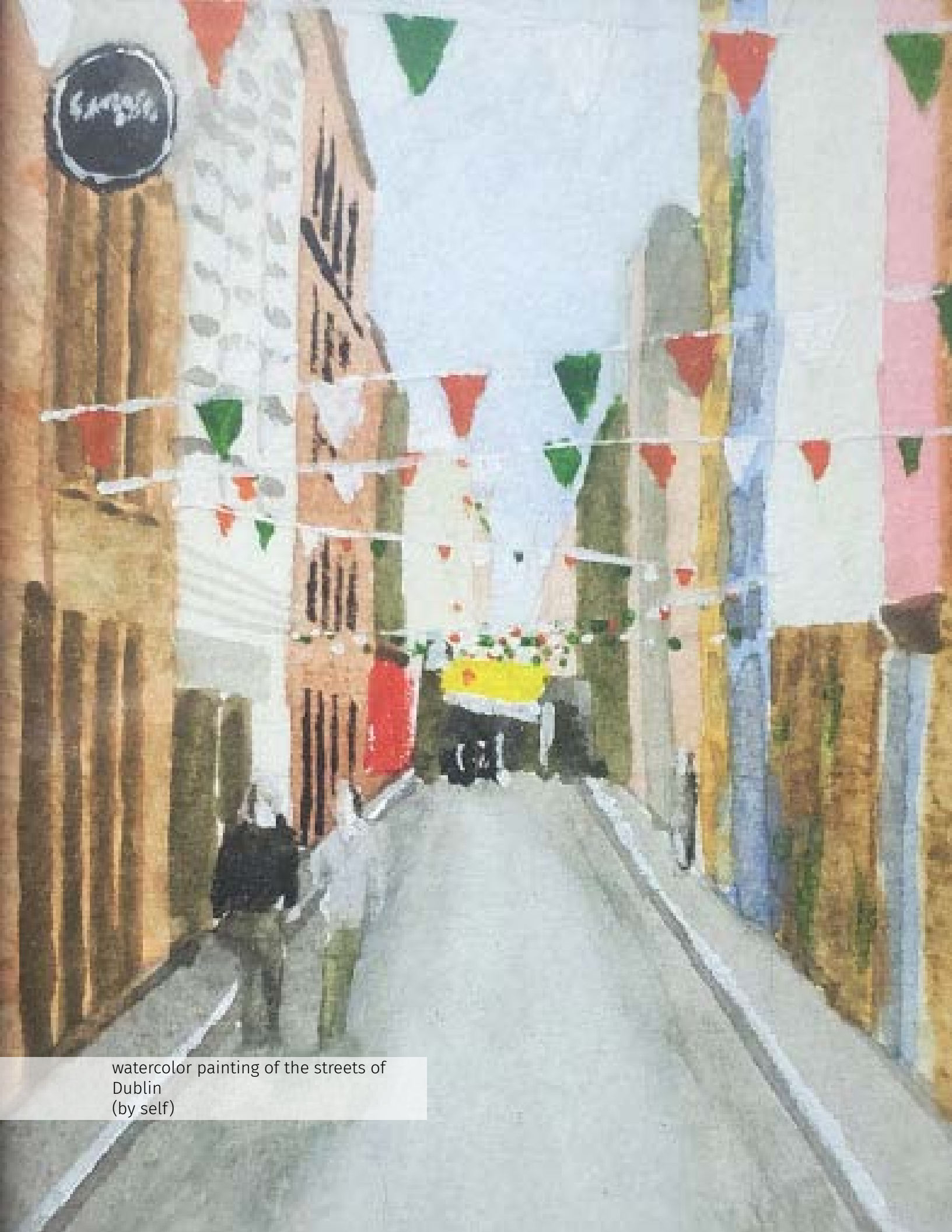

watercolor painting of the streets of
Dublin
(by self)

image

It is true that countless facades of the city stand exactly as they stood in my childhood. Yet I do not encounter my childhood in their contemplation. My gaze has brushed them too often since, too often they have been the décor and theater of my walks and concerns.

-Walter Benjamin¹

The word image comes with many meanings. It is a representation of external form, a visual impression, an optical appearance, a mental representation or idea, a metaphor, an idol or a general impression.² It stems from the Latin *imago* meaning image, copy, imitation, or likeness. It produced the word imagine.^{3,4} It is a word that exemplifies experience in a place and time. The word image will be used in all the ways previously mentioned but it is important to understand that all those definitions amount to the same phenomena which is a representation of the world through our cognitive faculties. Since this writing is focused on how humans perceive the world, how we see ourselves in it and how we sculpt it, we accept here that what we experience is through our bodies and understood through the complexities of our nervous system. The image is at times scenic, individual and collective. We share

images across cultures. One of the prior definitions of image mentioned is “to copy.” Humans are mimetic in nature and therefore, it is through this sharing of images and ideas that we collaborate to understand our world and communicate across barriers. The image is the medium of experience. Although much of what will be said regards visual experience, we must try to divorce ourselves from thinking of image as strictly visual. It engages all the senses, both conscious and non-conscious, what we conceive as the past, the present and what we imagine as the future.

/ direct experience in the theater of transactions

When Walter Benjamin wrote a memoir of his childhood, he challenged our understandings of memory and spatial experience. He wrote about everything that he could remember of growing up in Berlin: the streetscapes, exchanges, the zoo, markets and what he could remember about the architecture. In the quote at the beginning of this chapter, Benjamin is highlighting here something that describes most of our architectural experience. It forms the backdrop, the theater set of our life.⁵ It persists and adds layers of memories; both new and old exist in the image of a building. The image of a building can seem clairvoyant, as an experience in one place can connect memories of what became of others. The city was memory, and the memory was not an instrument, but embodies the essence of the city as its theater.⁶ The streets are where our memories play out.

Memory is the medium of past experience, as the ground is the medium in which dead cities lie interred. He who seeks to approach his own buried past must conduct himself like a man digging. This confers the tone and bearing of genuine reminiscences... For the matter itself is only a deposit, a stratum, which

yields only to the most meticulous examination what constitutes the real treasure hidden within the earth: the images, severed from all earlier associations, that stand – like precious fragments or torsos in a collector's gallery – in the prosaic rooms of our later understanding.⁷

This statement is rich with embodied experience and observation. Benjamin divorces what the architecture of the city is, its representation in our minds, and the emotion it collects throughout time. Matter, the physical world we encounter, embodies an image in each moment. That moment is interred in our past as an experience of emotions and connections that in turn are collected in our memory among other fragments in the unpoetic repository of information that is our brain.

He made a brilliant observation that, despite it sounding common sense in an argument, isn't what we normally think of our memories. "Reminiscences, even extensive ones, do not always amount to an autobiography."⁸ For him, autobiography has an element of time and continuity. Memory has to do with space, moments and discontinuity. Regardless of how long a memory seems, what image appears to the individual is the form it takes at the moment of recollection. The image doesn't exist in the past, nor the future for even that matter. It exists in the fleeting moment you recall it. At the time of his writing, the town was recalled as a "theater of purchases" for his memories were of shopping, store counters, price tags and suits.⁹ But the more he envisioned of his past, the more he realized how little a role people played in them. Even the fondest of memories regarding social encounters include significant information of our settings. He once made a diagram of his life from memory and new exactly at that moment how it would be done. In the following years, he lost the diagram and desperately tried to reproduce it, but at this time, the way he remembered his past had changed. What once was a diagram that included family trees became a labyrinth of paths and entrances that

led between individuals. What he observed is that memory kept leading him back to the same people, and these people connected to a distinct setting of facades and houses.¹⁰

Benjamin would therefore not be surprised if he were to learn from contemporary scientists that memory is spatially encoded. What this means is along with event information, each experience includes a space and a movement. When we remember the price of a dress, we also remember the storefront display, the weather outside the store, the movement of walking by the window and the setting around the shop. All of this is connected to the same memory as a full image of that experience. This includes the smells and sounds of the street. Our minds store much of this information as pertinent to that experience. We are spatially preferenced because it is essential to survival. Remembering all the individuals of a scene isn't necessary if we are to encounter that moment again, however, the physical setting and signals of potential threats are. We will cover more on these topics in a later section.

Both Walter Benjamin and Friedrich Nietzsche were cautious of history, identity and its use in contemporary society. Nietzsche wrote a few books on the topic, one specifically titled *The Use and Abuse of History*. In this book, Nietzsche new that history would become commodified and eventually be exploited and manipulated. He found history to be a way to tie people to their companions and circumstances. In his words, history served life by "anchoring the less gifted races and peoples to the homes and customs of their ancestors and keeping them from ranging far afield in search of better."¹¹ History would become used to control individuals through constructing a lifestyle and historical narrative. Monuments would be erected to reinforce these narratives replacing meaning of an image with intent. Benjamin saw the same issues first hand as fascist organizations began to take hold in Europe. He saw a world where mass production of image and text would lead to an ability to remove an object from its

context. Neil Leach summarized this as a world where “truth” was an illusion that could be framed and distorted to reinforce the mythology of history.¹² Benjamin’s reasoning was concerned that a reproduced image could place a copy of an image in a situation to which the original could not. This divorces the meaning from the object, the here and now as he put it. This especially was the case with film as to him, the representation of human beings by means of an apparatus made an individual’s self-alienation highly productive.¹³ Benjamin’s time was one of fascist movements, violence and division. A time where mythological histories and reinforced identities and strengthened fears of a changing environment. History and image were combined to control and influence the masses by curating a history and collectively reinforcing the narrative. After the war, the use of image proliferated as capitalist economies realized the sales power of the image, changing our experience of the built environment.

Theorist Guy Debord was intrigued with how we experience and remember our environments. He was part of a group of individuals known as *The Situationists*. This was a collective that believed we needed to focus on reestablishing experience by focusing on specific situations. Modern architecture had removed the genuine experience of cities by mechanizing the experience of life. Gridded blocks of real estate failed to engage our psyche and form meaningful memories. Cityscapes were designed to be pristine images of a forward-thinking society. The world was striving to embody the modern human and comply with its image. It was this obsession with modern image that Debord rebelled against. He believed the image had displaced reality.¹⁴ The city wasn’t a totality in experience. Everything was diluted down to images and superficial commodities as society became preoccupied with the image. This process of saturating our experiences with images and spectacles worked to alienate ourselves. We were bombarded with images of what our life could be or how we could look. The Situationists saw architecture as a way to reestablish an experience that is “deliberately

lived.”¹⁵ The Situationists developed a map of Paris titled *The Naked City* that envisioned the city as a series of “psychogeographical turntables” that connected parts of Paris. The metaphor of locomotives was employed specifically because it is self-propelled but bound to a track as was the experience of the individual. The pedestrian was bound by the “instrumentalized image of the city propagated under the reign of capital.”¹⁶ To break this, the city was mapped as experienced by what was termed *dérives*, spatializing actions where an individual directly engages with the environment. The city wasn’t experienced as an overall infrastructure, but as a series of experiential moments.¹⁷ This brought experience back to the time before accurate city maps, where spatial experience and location was based on recognizable landmarks such as a church, plaza, axis, monument or market.

Robert Venturi saw this saturation of images in daily life as an opportunity. He believed the way to combat modern architecture was with a generic form adorned with symbolic content, scenographic imagery and flexible iconography that celebrates plurality and changing contexts. He believed the use of electronic iconography was essential to the 20th century and advanced past 19th century engineering rhetoric. Architecture should be about generic form and iconographic expression, not sculptural expression.¹⁸ He believed that iconography would be the road to pluralism and inclusion. Architecture that was evolutionary instead of revolutionary would embrace the contemporary existence while maintaining the familiar. He even states that Michelangelo never invented a new style, just became a master at an existing one.¹⁹ Leach argued that Venturi ignored content, he fetishized the image in an effort to engage experience while not questioning values. His efforts to capitalize on the power of image and representation ignored context and removed meaning.²⁰

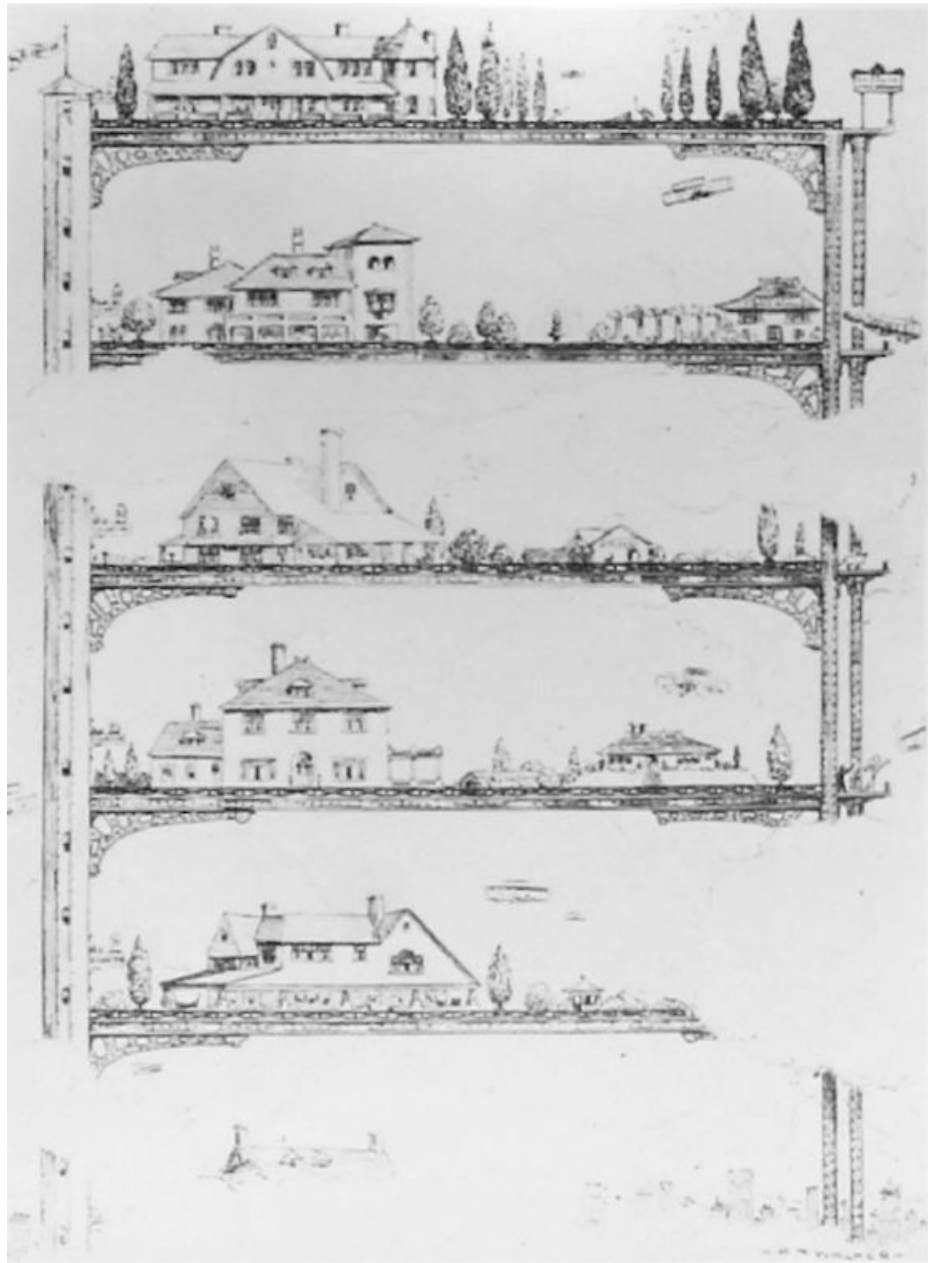

Figure 6: Life Magazine published this image in 1909 as a response to skyscraper design and housing; it provided commentary on the representation of culture in anonymous highrise structures.²¹

Architect and theorist Rem Koolhaas entered this discussion with his prominent manifesto *Delirious New York* in 1978. His work discusses numerous concepts of the city; importantly it acknowledges human desires and shifting identities. City dwellers would flock to theme parks where an oversaturation of experiences would whisk them away into worlds of momentary fantasy and disbelief. The city experience was one of surrealist desires. A new typology arose, literally and figuratively: the city block. Entire blocks of buildings grew to new heights creating new experiences removed from the street life. These new types of buildings were freed from aesthetic obligations by replicating floor after floor, vertically facilitating anonymity and mystery. No longer was architectural form bound by identity, it was an object that concealed its true experience. He briefly discusses a Life Magazine article that provided a cartoonish sketch of a high-rise of houses. The commentary was one of identity and private life in the simultaneously anonymous and public life of a skyscraper (see figure 6). People desired this anonymity and embraced the excitement.²²

In 1995, Koolhaas published an essay titled “the Generic City.” This essay raised further critical observations about identity and the city by asking “what are the disadvantages of identity, and conversely, what are the advantages of blankness?”²³ Koolhaas envisioned the possibility of homogenization being the next great liberation movement.

Identity is like a mousetrap in which more and more mice have to share the original bait, and which on closer inspection, may have been empty for centuries... Identity becomes like a lighthouse – fixed, overdetermined: it can change its position or the pattern it emits only at the cost of destabilizing navigation.²⁴

He believed the Generic City could liberate us from the straitjacket of identity. History is itself abused and has an “invidious half-life.” Exponential human population growth and

development will render the past too small to be shared by those alive. The Generic City is founded by people on the move and is heavily multiracial. Its modus-operandi is to abandon that which doesn't work and breaking the blacktop of idealism with jackhammers of realism. Historical quarters would become lip-service that celebrate the past "as only the recently conceived can."²⁵ His work is parts sarcastic, humorous and deeply critical of human society. It again criticizes our desire for identity while simultaneously criticizing our desires for anonymity. Overall, he embraces what humans are and speaks of our characteristic tendencies in terms of urban development while appreciating contemporary life over conservative preservation.

Bookending our conversation on identity is a return to Neil Leach. He devoted an entire book to agency and identity within the human ecosystem, his theory of *Camouflage*.²⁶ Identity was mimesis, a process that allowed us to assimilate and empathize through our similarities and differences. However, simply replicating our environment wasn't enough because it created a sense of being trapped that caused us to strategically choose moments of dissonance. Camouflage becomes an agential act by which we establish our identity and differentiate ourselves from a certain backdrop. We could tweak our mimetic behaviors to establish patterns of difference that gave us a stronger sense of self.²⁷ We establish our identities with objects through projection and introjection, investing history into buildings. We create myths of our homeland to project values into objects such as a flag that forms the institutions of our collective definition.²⁸ Camouflage is an apparatus, a medium of self-empowerment that is forged through image and commodity and constitutes human identity through representation.²⁹



Figure 7: This diagram represents an understanding of Bill Brown's other things; in his theory, a thing is an object that becomes of concern to the subject; all objects exist in reality but what we experience is a thing; an object is of concern when it engages us to serve a function other than its general existence.³⁰ (diagram by self)

/ representationalism and realism

Where images become exploited is often in the realm of representationalism. The easiest way to define representationalism is with a tripartite relationship. The three parts are (1) a subject, (2) an object and (3) what the subject sees. Multiple philosophers have their theories about this moment of interface with reality. For Plato, real objects exist in the intelligible world outside of perception and only attainable through effort and understanding.³¹ Heidegger believed an object became a thing through nearness, where it gathered the fourfold of earth, sky, mortals and divinities.³² Graham Harman re-envisioned the fourfold as the “quadruple object.” Here, there are numerous representations of an object based on four poles: (1) real objects, (2) sensual objects, (3) real qualities and (4) sensual qualities.³³ For Bill Brown, this was a simpler relationship where an object becomes a thing simply by become of concern. An object becomes of concern when it no longer serves only what it was made to do. An easier way to simplify this is an object becomes a thing when we must engage it.³⁴ In a cognition sense, this fits arguments where perceptions are products of internal states and there is a very strong understanding that we don’t all see the same thing. This in fact is an argument I make and try to describe in this thesis, however, there is a real ethical concern that must be acknowledged and dealt with.

With representationalism, it is often argued that perception equals truth and therefore reality is subjective. In all its Cartesian glory, we tend to believe what we are seeing is accurate and if someone else disagrees, they probably aren’t seeing it right. Here, we have a divorce of reality and truth, of matter and meaning. This ontological dilemma combined with the ability to manipulate images and context lead to easy exploitation of individuals. Constructivism is the idea that all knowledge and therefore our own personal reality is constructed from human

perception and knowledge. Both philosophical standpoints put importance on human perception as the basis of reality. Karen Barad points out that representationalism has a common-sense appeal and seems natural.³⁵ What realism and Barad's *performative* approach does is it refocuses "truth" from the divide of representation and the object awaiting representation, instead focusing on the process of representing. It is a questioning of representation rather than an outright acceptance of it. It views the process of representing as a direct engagement with the physical world and not a separate process removed from reality.³⁶

It is easy to see how representationalism can lead to ideologies and control of meaning and perception. If representationalism seems natural, and we are led to believe other individual's realities aren't of the same reality, the moment of difference can be exploited. This is where ideology steps in and tries to dictate reality by allowing leverage to convince others that our perceptions are right or moral. If we take the post-humanist approach, we can accept that perception is flawed. Doing this will increase the importance of getting other individual's points-of-view to help address problems. The ego-centric humanist mindset believes a single person sees their "truth" but that individual, given a platform, has the ability to make others see that "truth" and debase all others. If we call into question this process, then we question motives and context to better understand what the reality of the problems we face is.

[page intentionally left blank]



from the Peter Zumthor designed
Kolumba Museum in Cologne
(image by self)

perception and process

The new paradigm of human cognition begins by reframing the relationship of our thoughts to our bodies. Cognitions do not emerge in tension with a corporeal self, as was thought for centuries, nor from a disembodied mind – a paradigm encapsulated in the dualistic “mind-body problem.” Instead, cognition is the product of a three-way collaboration of mind, body, and environment.

-Sarah Williams Goldhagen¹

Before we get to discussing the physical science of architectural experience, we must cover a few general topics that will help us understand what is going on. First let's provide a simple picture of how information passes through the brain. When signals enter the brain, they alter a cell's charge. This excites the cell and causes an electrical signal to pass on to the axon terminals. These terminals exchange ions with the input of other cells, known as dendrites. A single cell has many branches of dendrites and axon terminals that connect to various brain regions and other cells. Depending on the cell, it takes a certain amount of excitement to pass on the signal. The diagram below shows these components and the direction of information flow (figure 9). We should become familiar with the word *potentials*, which is a word used to

describe electrical charge in the brain. Cells have resting potentials which are a given negative electrical charge. When this charge becomes less negative or even positive, what is termed an *action potential* is created. An action potential causes a signal to be transmitted through the cell body and onto the next cells. That's about as complex as we'll go regarding cell anatomy and chemistry.²

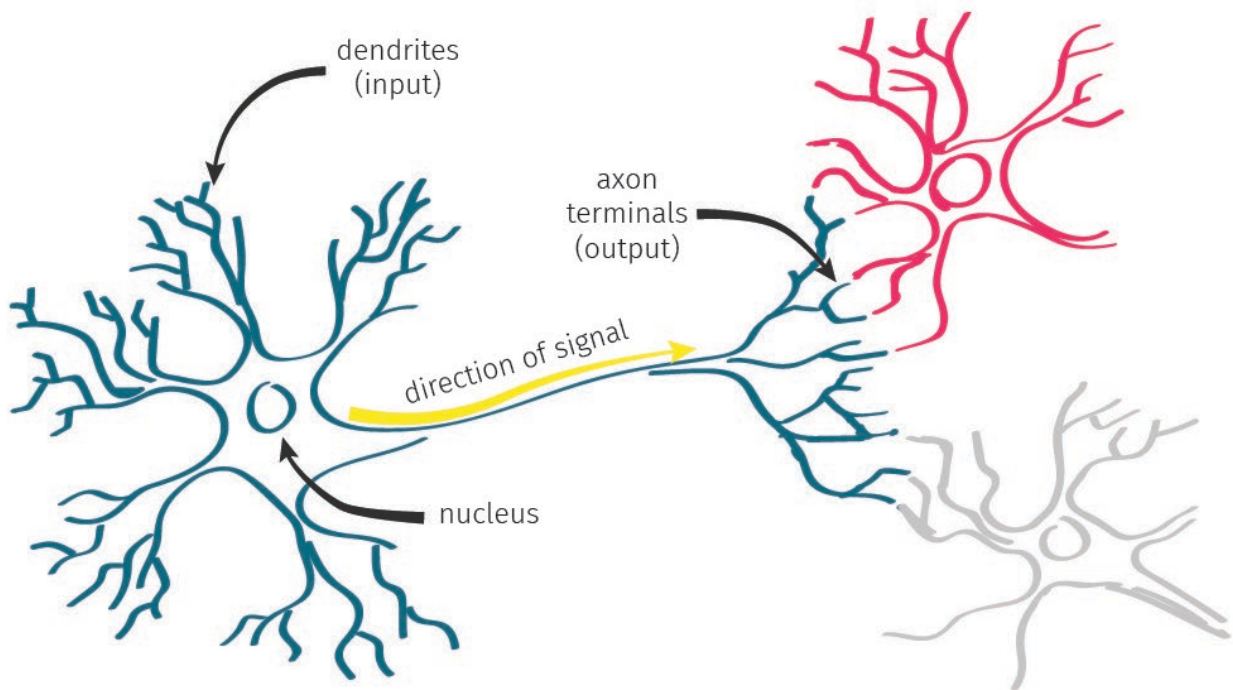

Figure 9: the anatomy of a brain cell; there are upwards of 100 billion cells in the human brain forming these intricate network connections; diagram by self

The second topic to be familiar with is endocrinology and the brain (hormones). There are two ways information is disseminated through the brain: (1) neurotransmitters at synaptic connections and (2) hormones. In the last paragraph, we discussed neurotransmitters. These

are very specific instances between cells in the brain. When a hormone is released in the body, it enters the blood stream and impacts potentially trillions of cells. In the brain, there are localized hormone processes that create chain reactions of hormone secretion. Specific hormones bind to specific cell receptors causing potentials and changes in sensitivity. A list of common hormones present in the brain is dopamine, serotonin, melatonin, adrenaline, cortisol, endorphins and oxytocin. Some of the impacts of these hormones are known to impact happiness, depression, focus, stress, pain and social bonding. Hormones are released in various time increments, some can last for years where others last for fleeting moments. Hormones can alter cell metabolism, kill cells, and can turn certain genes on or off. To understand behavior, it is good to know what triggers hormone release in response to social environments and stimuli.³

It is important to keep in mind that brains are networks. They are not linear processes but complex networks of nerve connections. A network is self-organizing, and functions based on energy flows. Like all networks, there is a constant flow of energy. The brain has what is termed the *default mode network* which cycles signals through the brain during resting states. One theory is that this process keeps the brain active for alertness and maintenance. This network is active when there is a reduction in external stimuli, meaning it is the home for mind wandering, dreaming and thinking to one's self (see figure 10).⁴ There is always information flowing in your brain. When external stimuli initiates a response, resources are devoted elsewhere to deal with concerns. This highlights the fact that there is no linear nature to the brain, energy moves about in network fashion, each input impacting numerous outputs. This also highlights the network feedback loop. Much of the brain is a negative feedback loop meaning the system has a balance point, stimuli excites the system and

responses seek to diminish the stressors and return the body to balance. Numerous parts of the brain have cyclical communication patterns that prohibit/inhibit synaptic transmissions.

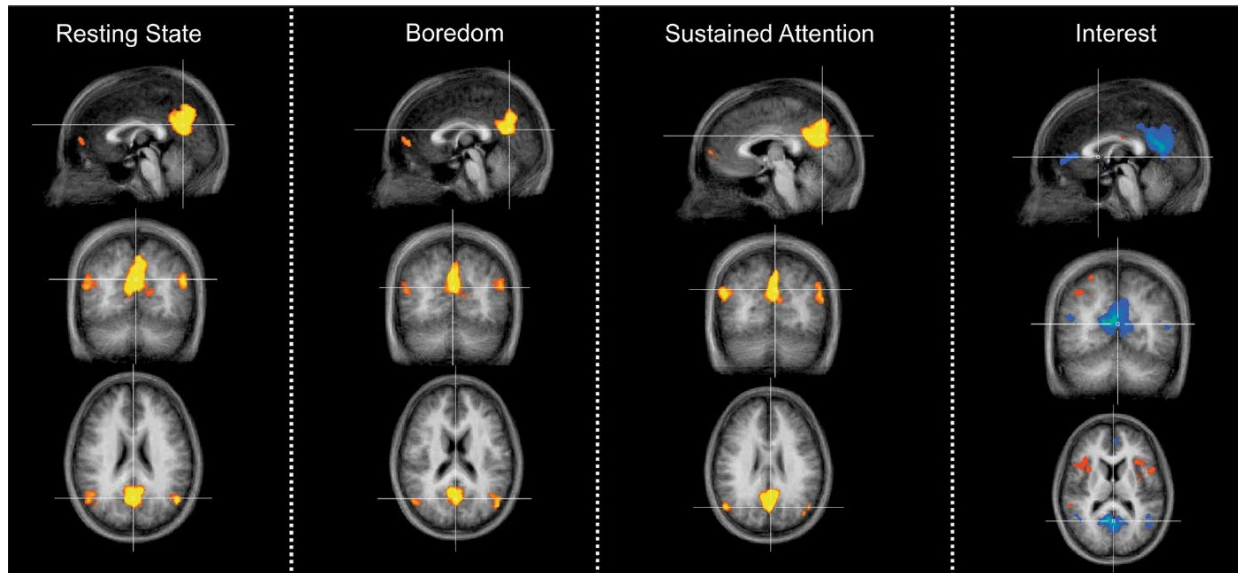

Figure 10: these images are from a study examining the default mode network within the brain using fMRI scans; it shows where activity in the brain is upon specific levels of stimuli⁵

These concepts should be kept in mind from here on out. Information transmits through neurotransmitters that alter electrical charge, hormones also impact signal transmission over longer periods of time, and the brain falls under network theory principles.

The final concepts to keep in mind are the terms *habituation* and *sensitization*. These terms deal with changes in how receptive brain cells are to stimuli. It can apply at neuronal cell levels and overall behavioral observations given we understand that behavior is a product of neuronal processes. Habituation refers to a reduction in sensitivity. Sensitization refers to the opposite, an increase in receptibility of a stimulus. When it comes to dopamine release in the

reward systems, we habituate to stimuli with repetition. That means, nothing is ever as good as the first time. This is essential to controlling motivation and heightening our willingness for learning and discovering new things. It also means the more we consume, the hungrier we get.⁶

/ the visual system

Light enters the eye through the pupil and is received by photoreceptors on the rear wall of the eye known as the retina. There are various types of photoreceptors. The two well-known photoreceptor cells are rods and cones. These are theorized to have variants among them, but that topic is irrelevant to this study. A third type has more recently been accepted and is known as *intrinsically photosensitive Retinal Ganglion Cells* (ipRGC).⁷ Rods are most functional at low light, providing *scotopic vision*, that transmits little to no visual color information and provides poor acuity. Rods predominately make up the area outside of the *fovea*. The fovea is a small area on the retina where light is focused. Cones cover much of the fovea, increasing in density 200-fold with the center of the fovea being rod-free. Cones are activated most where more light is present, providing *photopic vision*, responding to brightness and chroma and providing a more acute image.⁸

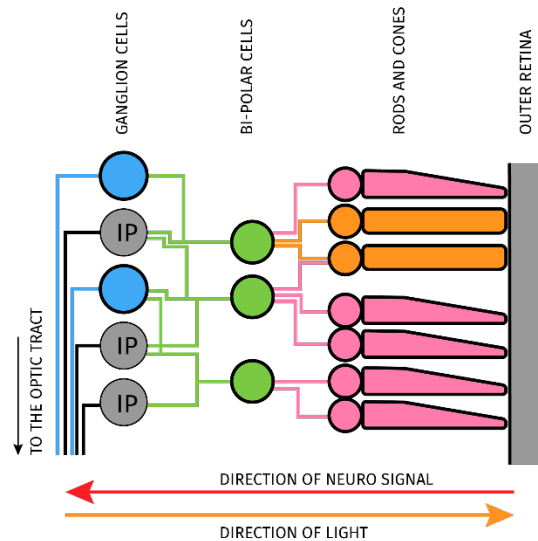

Figure 11: the diagram shows the direction of light and path of signals; light travels to the back of the retina where it triggers a chemical reaction that alters charge in rods and cones. Signal carries through series of cells between the photoreceptors and ganglion cells before heading towards the optic tract (diagram by self, not shown are amacrine and horizontal cells)

These photoreceptors constitute *image-forming* processes that transmit light into the brain.

The cells are activated by chemical changes caused by photons in the retinal membranes.

These changes cause *graded potentials* that alter polarization by dilating channels in the outer cell layer. These channels control flow of charged particles that cause potentiation in the photoreceptor cells, sending signals to the brain through neural communication networks. This process is known as *phototransduction* and converts light into neural information.⁹ This is the first step in the visual experience of our built environment.

The third type of photoreceptor cell, ipRGC, is starting to become known in architectural circles. IpRGCs transmit light into a *non-image-forming* process. These cells are at the center of behavioral studies of light quality, especially daylighting. *Melanopic vision* refers to the effects of light on these cells and the photopigment *melanopsin*. The ipRGCs get both input

from rods and cones and, as the name eludes to, are intrinsically photosensitive (they are photoreceptors as well). Potentials are sent via these cells to the *Supra-Chiasmatic Nuclei* (SCN) of the *hypothalamus* and are closely connected to the *central nervous system* (CNS) (see figure 13). The connection to the CNS makes ipRGCs key to regulating biological rhythms known as *ultradian* (REM sleep cycles and pupillary diameter), *circadian* (daily sleep/awake cycles, alertness, and melatonin suppression), *infradian* (menstrual), and *circannual* (seasonal hormonal changes). Architects and lighting designers are currently focused on circadian rhythm as science has shown these functions to be easily impacted by design strategy. Non-image-forming effects that can be impacted by architecture include melatonin suppression, alertness, core body temperature, and heart rate cycle.¹⁰ Circadian rhythm and the SCN dictate metabolism and secretion of glucocorticoids such as cortisol (which impact stress, metabolism, inflammation, and energy levels among other things).¹¹

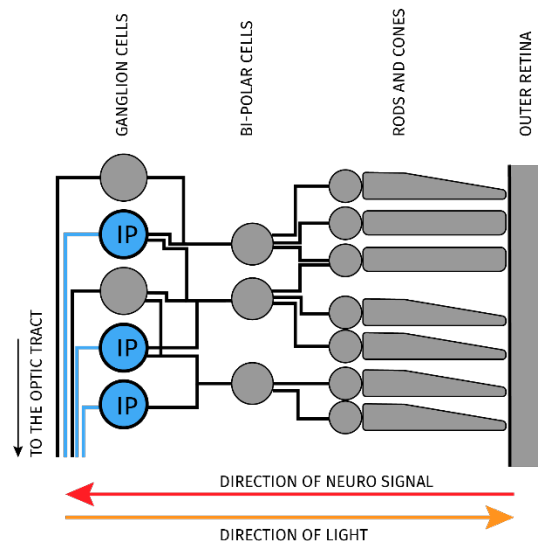

Figure 12: the diagram shows where intrinsically photosensitive retinal ganglion cells are situated the chain of reactions (diagram by self, not shown are horizontal and amacrine cells)

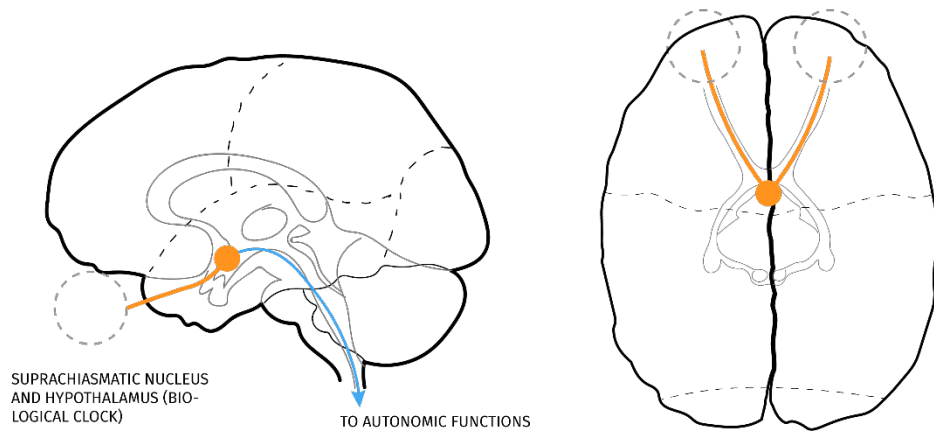

Figure 13: visual stimuli sends non-image forming information to the hypothalamus to help regulate bodily rhythms and hormone levels (diagram by self)

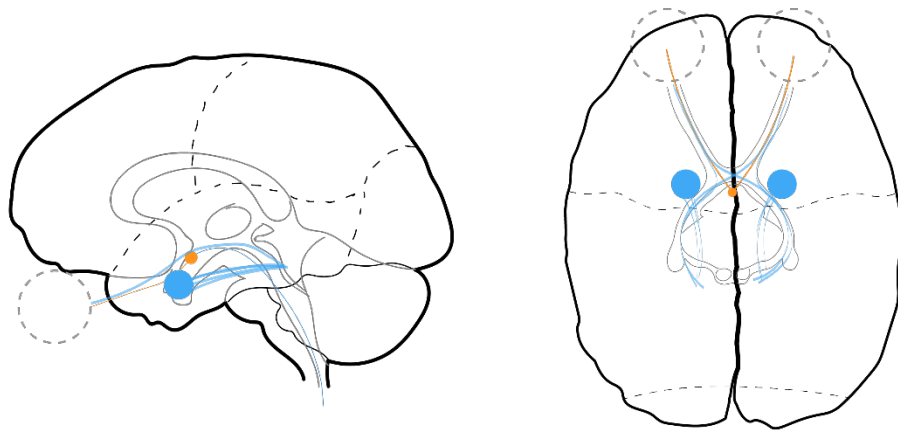

Figure 14: one of the image-forming information pathways leads through the superior colliculus and onto the amygdala for threat perception; the amygdalae are represented by the blue dots (diagram by self)

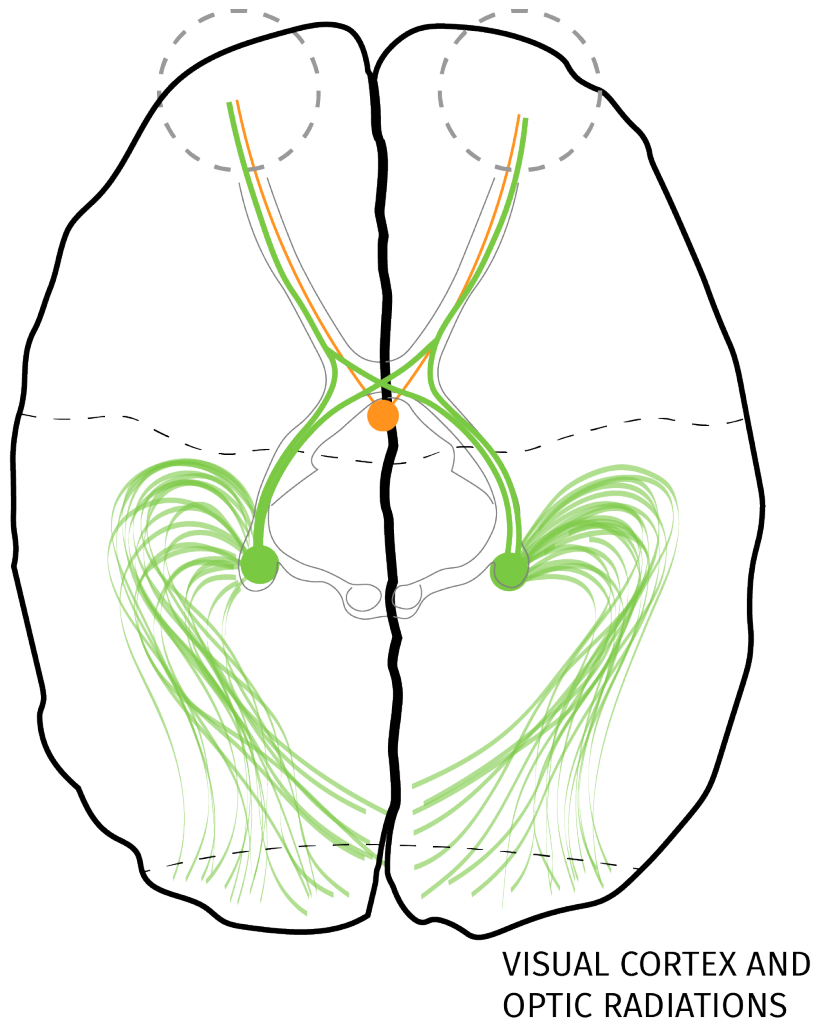

Figure 15: visual signals travel through the lateral geniculate nuclei (shown as green dots) and passed on to the visual cortex near the rear of the brain (diagram by self)

To summarize, design intent articulated through material and light qualities can impact the perception of stress, overall energy levels and heart rate. Disruption of circadian rhythms has been linked to cell cycle regulation, DNA damage response, metabolism and even to breast cancer.¹² All this is accomplished before information cycles through the cognitive functions of the brain. Architecture has an immediate impact on an individual's response to an object or space. Light quality can generate perceived stress and anxiety without deeper brain function.

There are two known paths of image-forming vision. The first is the primary visual pathway where photoreceptors send signals through the neural networks towards the *visual cortex* (see figure 15). On route through the *visual pathway*, the signal from retinal cells passes through the *lateral geniculate nucleus* (LGN) within the *thalamus*. Spatial processing occurs in the thalamus before being sent to the primary visual cortex.¹³ From here, information is passed on to the *striate cortex* (also known as the *primary visual cortex*, or V1) of the *occipital lobe*. In the occipital lobe visual information is processed, including (but not limited to) edge orientation, color, and direction of movement. Different regions of the visual cortex and middle temporal areas process different aspects of the visual field, each with its own visual image. If damage is inflicted upon one visual area, individuals are still able to see with information related to that area missing (i.e. people who suffer from cerebral achromatopsia which leads to seeing the world without color despite fully functioning rods and cones).¹⁴ From here, information travels to various regions of the brain based on received patterns and potentials to be categorized and interpreted by both non-conscious and conscious processes.

The second image-forming pathway leads to the limbic system, which is the subject of the next section (see figure 14). The visual signals are sent through the *superior colliculus* and on to the amygdalae. Various exchanges between the amygdalae and hypothalamic structures

instigate what is known as autonomic responses. These are quick responses to rapidly processed stimuli that serves to facilitate aversion to threats. This is where we establish non-conscious automatic preference for objects, scenes and individuals.¹⁵ This is the source of immediate apprehension to specific stimuli that fuels prejudice and bias. Although it is an essential survival function, a lack of diversity has led it to be the source of many concerns regarding racism and isolationism.

/ the limbic system and first impressions

There is a simple metaphor to describe brain layers popularized by neuroscientist Paul MacLean in 1960. Although not essential to actual brain functionality, it helps explain behavior. The first layer is the ancient part of the brain that serves autonomic and regulatory functions such as body temperature, breathing regularity, blood flow, hormone release and involuntary muscle movement. Layer two evolved more recently and is the source of emotions. It can heighten or dampen response based on emotional dispositions and trigger fear and anticipation prior to higher level processing. Layer 3 is the most recently evolved and is more common in primates than other species. There is overlap between the layers and the process is far less linear than just described, however this helps understand the relationship between functions of brain regions. The limbic system forms a crucial interface between layer 1 and 2. This is where emotional response converts into bodily response.¹⁶ This has significant importance to experience as input ranges from short-cuts for prompt response to regions that impact the sense of beauty and reward.

You can't talk about the limbic system without mentioning its big players, the amygdala, hippocampus and hypothalamus. The amygdala is a known source of fear and anticipation responses. The amygdalae are often attributed to aggression. Numerous studies from monitoring and visualization that records behavior after damage to an amygdala show a direct relationship between aggression and this limbic structure.¹⁷ Studies have shown that damage to one amygdala (you have one on either side of the brain, see figure 14) impacts response attached to the given portion of your visual field. This means differences between your amygdala will generate a different response depending on which eye, ear or side of your body you perceive the stimuli from.¹⁸

The amygdala's relationship to fear and anxiety is another prominent study, especially when it comes to *post-traumatic stress syndrome* (PTSD). This is important because it shows the importance memory plays in fear response. Prolonged stress is linked to an increase in size of the amygdala as seen in PTSD victims. Social scenarios and uncertainty also show activation of the amygdala that are important to our desires for social acceptance and conforming. The amygdala is surrounded by the *basolateral amygdala* (BLA) which is the home for learned fears. Neurotransmitters between the two structures can change, altering the sensitivity to stimuli. These observations show the amygdala's role in social and emotional decision facilitating *implicit bias*.¹⁹ This process has been studied by University of Washington psychologists who developed the *Implicit Action Test* (IAT) that has been used by numerous researchers, sociologists and psychologists to study implicit bias and automatic preference, specifically regarding racism.²⁰ The final note worth mentioning is how the amygdala functions in anticipation. Studies have formulated theories that the amygdala activates in valuations regarding reward, more importantly the potential that a reward may not arrive. This is an anxiety function regarding uncertainty.

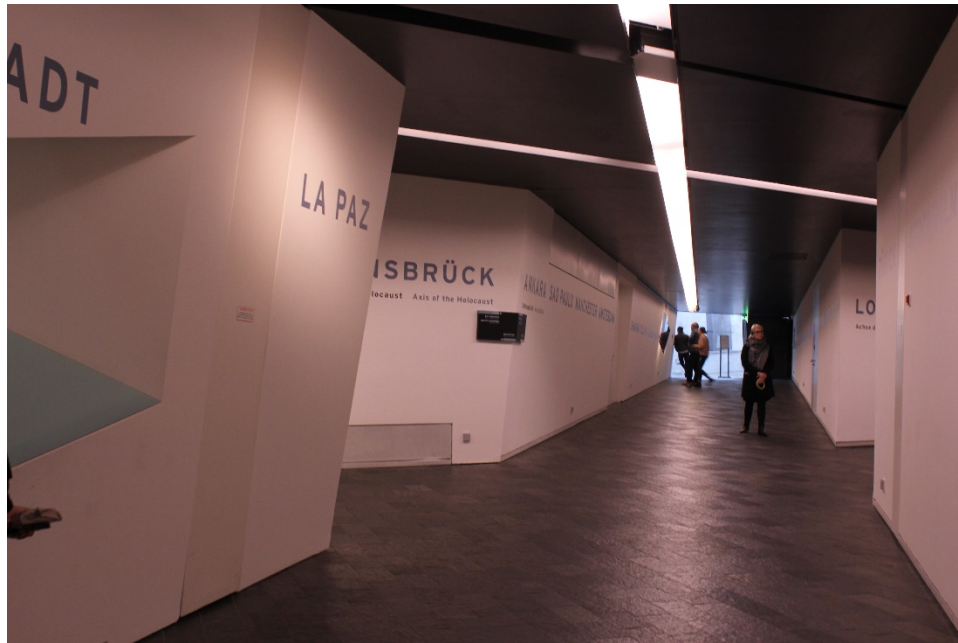

Figure 16a: an image from the Jewish Center in Berlin designed by Daniel Libeskind; a lack of parallel lines accompanied by a forced perspective, slanted walls and sloped floors causes an initial fear response as the space doesn't fit typical schema of upright walls and level/plumb surfaces (image by self)



Figure 16b: an image of Janet Cardiff and George Bures Miller's work titled "Dark Pool"; a simple quotidian object gets transformed into an object of concern when placed in unorthodox relationships²¹

When it comes to architectural experience, stimuli that creates an immediate uncertainty, be it abnormalities to expected schema such as slanted walls or gradual decrease in ceiling heights (see figure 16a) or objects generally perceived as uncanny or out of context (see figure 16b). These experiences generate initial responses prior to any higher-level cognition. Furthermore, if a designer is employing anticipation, an intentional increase in uncertainty of reward will trigger response of aggression or fear that can raise blood pressure or breathing rates.

The hippocampus is known most for its memory functions. It's here that facts are stored and exchanges between the *prefrontal cortex* (PFC) and the amygdala connect perception and memory with emotion and response.²² Some professionals believe the hippocampus plays a critical role in relational or associative memories such as relating a stimulus to an expected schema.²³ In one imaging study, participants hippocampal region was more active when seeing an image that was different versus seeing one that was familiar. The more different, the more activation.²⁴ Observations have shown a correlation between reduced hippocampus size and depression. Hormone axis between the PFC, hippocampus and amygdala create glucocorticoid release, stress response, due to circadian rhythm conflicts and disruptions to homeostasis such as visceral, cardiovascular and respiratory stimuli. The role the hippocampus plays reduces the stress response, hence the smaller the hippocampus, the more stress an individual may feel. This, combined with an enlarged amygdala caused by prolonged stress, creates a recipe of aggression, fear and depression. The hippocampus maybe a key function dictating a negative feedback loop (one where homeostasis is sought through inhibition or facilitation) where reduction or damage can reduce the ability to reduce fear or stress responses.²⁵ The hippocampus is one of few regions of the brain that can generate new brain cells, a process known as *neurogenesis*. Approximately 3% of hippocampus cells are replaced each month and is influenced by injuries, exercise, learning

and pharmaceutical alterations. This is extremely important because it is our ability to input new information into existing schema.²⁶ That means a potential reduction of bias. It also means a habituation of aesthetic environments. What once triggered a stress response can become normal and non-threatening to the system. It is also important to note that the hippocampus is fundamental to cognitive mapping and goal acquisition. It works with adjacent areas such as the entorhinal grid-cells to establish a map of our environment to inform decision making, memory and movement.²⁷ An imaging study of London taxi drivers showed that upon completing their license exams, for those who passed, their hippocampus had become larger.²⁸ The hypothalamus is the interface that allows the limbic system to influence autonomic function and regulates the release of many hormones. It has connections to the brainstem, spinal cord and forebrain while being heavily associated with the pituitary, a source of hormones in the brain. The hypothalamus takes in contextual information through the hippocampus and amygdala as well as sensory inputs from visceral and somatic pathways from the brainstem then compares the information to what can be called “biological set points” to determine appropriate response to the information.²⁹ This is where what you perceive in architecture turns in to what you feel, the core of architectural experience.

Also, part of the limbic system is the *medial orbitofrontal cortex* (mOFC). This structure has been correlated to numerous valuations of reward but more importantly, it has connections to what we consider beautiful. In the image below, the areas where visual and auditory senses of beauty overlap is the region known as the mOFC (see figure 18-19).³⁰ The mOFC features much in value judgements as well, including prediction processing. It is a prominent target region of dopamine neurons that function in reward and motivation.³¹ These observations together show how value judgements on beauty impact emotional states and memories. In addition,

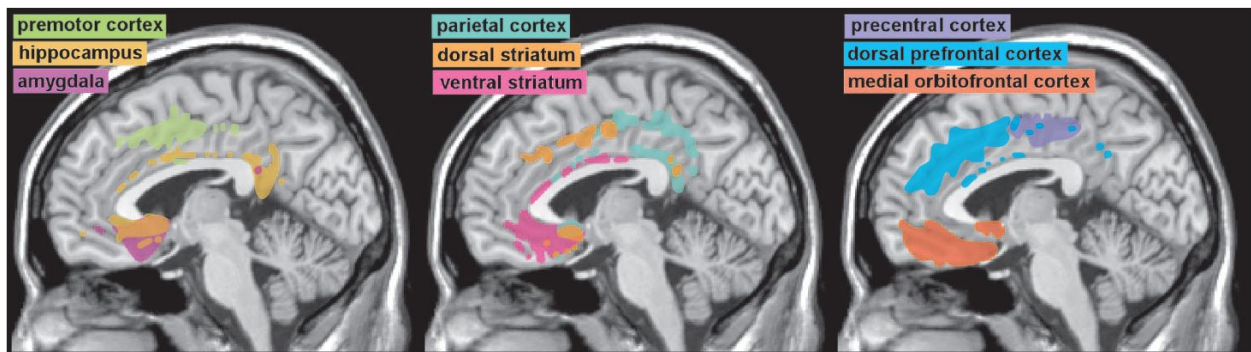

Figure 17: These images show various regions that have been discussed in this chapter; of importance here is the locations of the hippocampus, amygdala and medial orbitofrontal cortex³²

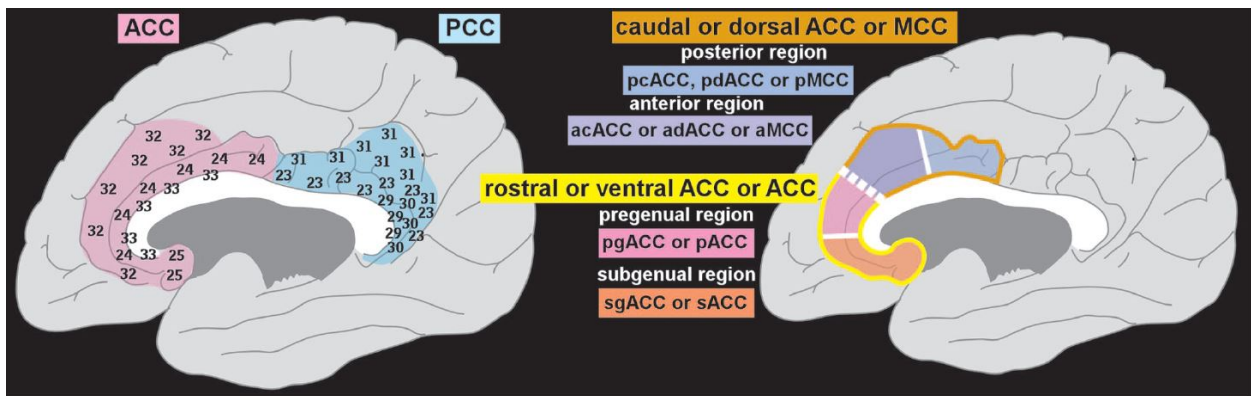

Figure 18: These diagrams show the location of the anterior cingulate cortex. The pregenual ACC potentially is of critical importance in understanding where consciousness exists in the brain.³³

the mOFC has direct connections to the *anterior cingulate cortex* (ACC)³⁴ which is part of the default mode network³⁵ and theorized to be a critical location in the brain responsible for consciousness.³⁶ These are just a handful of the main structures that produce the sense of architectural experience. G. Gabrielle Starr refers to this region of the brain as the “neural reference space” in her book on the neuroscience of aesthetic experience as it is responsible for much of emotional experience and self-awareness.³⁷

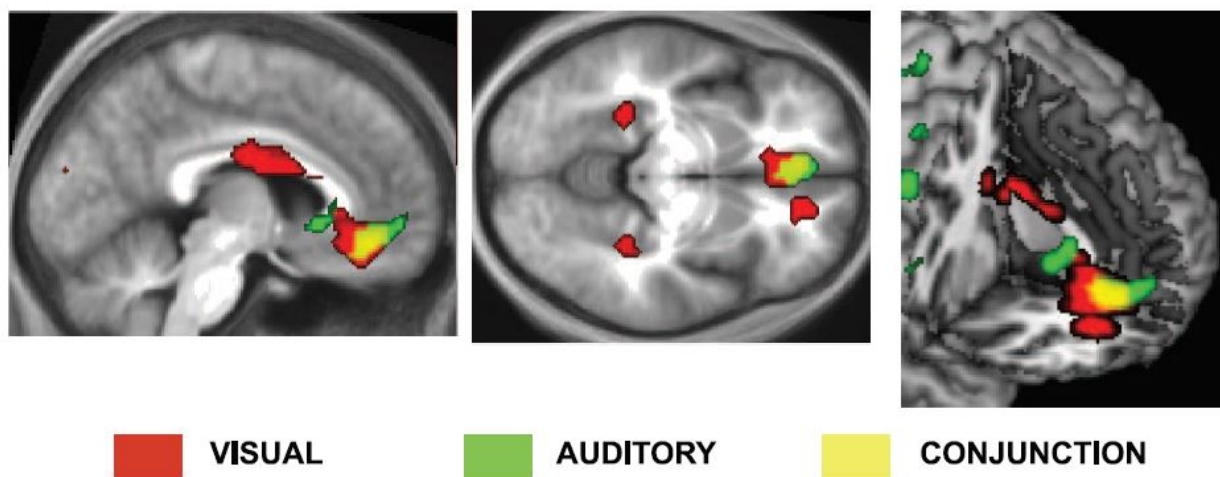

Figure 20: beauty and the brain; these images are from a study investigating the location of activity when perceiving beauty. The red shows visual stimulus, green auditory, and yellow is where the response overlaps.³⁸

/ reward and anticipation

The primary center for reward and pleasure is in the same area we previously were talking about. Nestled between the midbrain and forebrain just above your eyes are areas called the *mesolimbic* and *mesocortical* paths. Where they meet is a place called the *ventral tegmental area* (vTA) which is located near the brain stem in the midbrain. The mesolimbic extends from

the vTA to the limbic structures and the mesocortical extends towards the prefrontal cortex (see figure 20). Along these paths, dopamine is projected that drives motivation and reward as well as serotonin which increases the dopamine response. An important structure in this process is the *nucleus accumbens* which projects to areas that drive movement. Drugs such as cocaine and alcohol release dopamine in the accumbens. Chronic stress can cause a reduction in dopamine and decreases sensitivity which is a common concern with depression.³⁹

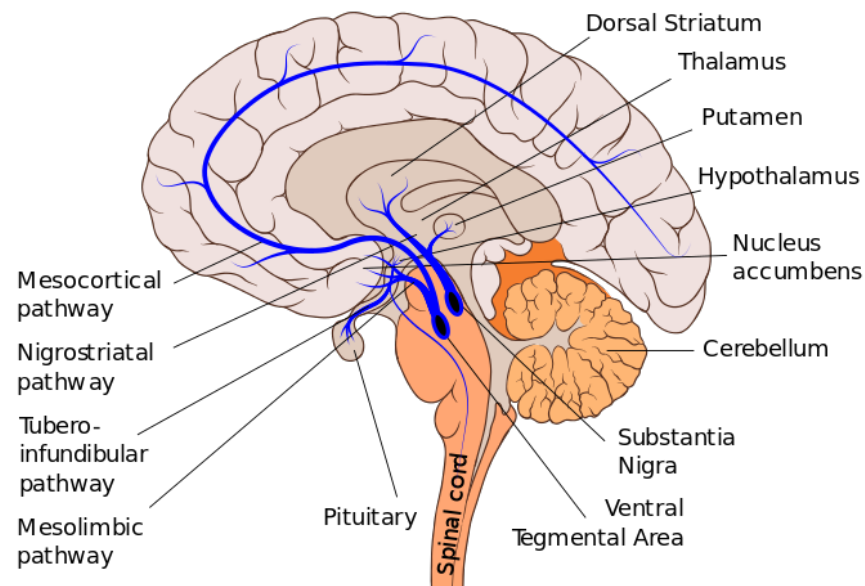

Figure 21: this diagram shows the dopamine pathways in the brain as well locations of the ventral Tegmental Area (vTA) and the nucleus accumbens.⁴⁰

Dopamine is essential to motivating movement and desires. It is released when you are hungry and sense food, when experiencing something new and it also encourages cooperation by releasing both for your reward and for witnessing another person's reward. It also is prominent in envy, releasing when seeing someone you are envious of suffer misfortune. The

biggest concern is habituation. As mentioned before, repeated exposure reduces dopamine release. This applies to urban environments and aesthetic stimuli.

If we apply this knowledge to the earlier discussions on architectural theory, iconography and direct experience, we can understand how monotony leads to boredom, lack of engagement and further lack of motivation. Not only were designers and theorists constantly subjected to the image of modernity, the cities began to take the shape. Any and all new experiences were replaced with expected schema and a lack of diversity. This is often why individuals are taken away by places like Disneyland and Las Vegas, the level of stimuli is not something they are used to, foreign and exciting. Anticipation of what lies ahead drives more dopamine. The graphic below shows how dopamine is released during anticipation (see figure 21).

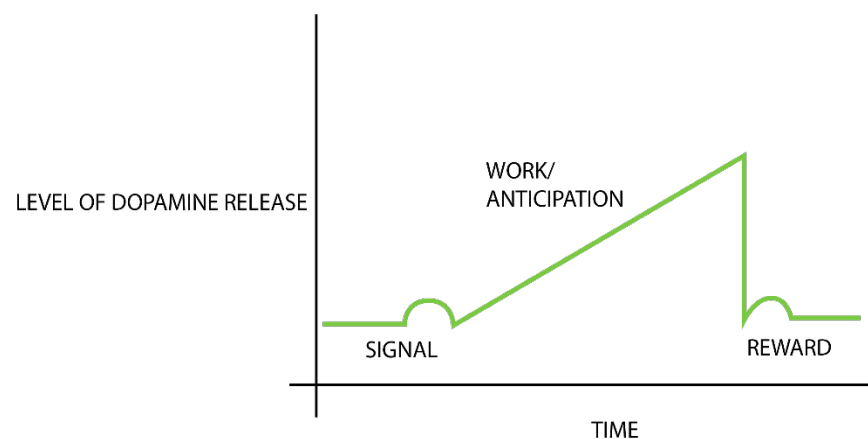

Figure 21: this diagram shows the rate of dopamine release in relation to an event; derived from a graphic in Robert Sapolsky's book *Behave*⁴¹

It is important for designers to note that more dopamine is released during the work/anticipation period than is released upon reward. The adage is true about the journey and not the destination; we get more motivation and excitement from the work versus the

result. Studies also show that probability of reward impacts dopamine levels. The proper level of uncertainty gives more excitement. The optimum level of certainty in studies appeared to be around 50%. Any more or less and dopamine release during the work/anticipation period decreased.⁴²

/ knowing

The biggest take-aways from that last two sections are the emotional ties to memory and value judgements, implicit memory's role in behavioral response, the function of automatic preference and the importance of schema. All of this is reliant to some extent on what we will refer to as recall. Recall is a function of association and by this we mean knowing, memory and understanding. Yadin Dudai, a professor of neurobiology and researcher on memory in the brain, chooses to use the term "internal representation" as this sufficiently describes the role recall fills in the brain.⁴³ Although knowledge, perception and memory are often referred to as different events and are often their own specific field of study, in our context they perform the same function. The other important aspect is a growing number of studies show that they in fact are essentially the same. Mental imaging studies have shown that mental images are produced by similar processes involved in the initial perception.⁴⁴ The location of physical changes caused by encoding of a memory must be involved in retrieval of that memory.⁴⁵ Memory is reflected in thought, so as Walter Benjamin alluded to, it doesn't exist until the moment it is recalled. Memory is an act, not a stand-alone physical entity. It is produced through processes of pattern recognition based on what stimulated the process and the learned connections and associations.⁴⁶ Memory isn't only what we know or have

previously experienced, it also formulates our predictions. We know what is coming because what we have experienced in the past and can associate with the given context allows us to generalize potentials of the coming moments.⁴⁷ Imagination is the same. We can imagine a different scenario or dream of a future world through only what we can associate with a given moment. When we experience something, that experience creates a pattern in our minds that is associated to that specific outcome, which we then use to understand other events.

Since the time of research for this paper was limited, there was a focus given to visual systems given the importance of vision in experience. As such, there was a focus on visual memory as well. There are three types of visual memory subsystems: (1) *Visual Sensory Memory (VSM)*, (2) *Visual Short-term Memory (VSTM)* and (3) *Visual Long-term Memory*. To experience VSM, stand in a dark room and take a photo using flash. The flash will be instant however the image on your retina will fade over the course of about half a second. VSTM is split into two processes. The first is *visible persistence* which represents a fleeting image that fades. The second is *informational persistence* which represents the information gathered from a visual stimulus. The role of VSTM to construct the field of view and provide quick abstract object associations as information is processed in the visual cortex. It allows the mind to bridge gaps of saccadic eye movements (rapid shifts of the eye), blinks and other brief occlusions. VLTM is retention of a mental image caused by encoding patterns in neural responses within the same regions of the brain that originally perceived them.⁴⁸

Schema is fundamental to memory. For every environment we have an expected schema that allow our body to know when things are of concern. Whether it is a street scene or kitchen, we have expected objects for each scene. Just as we expect to see a toaster in a kitchen, we expect to see a car in a street. If those are swapped, we'd be immediately alerted to the

toaster in the street or the car in the kitchen. We are far more likely to remember items that are out of place. It's not hard to understand how this is a survival mechanism that allows us to devote our energy towards items of concern.⁴⁹ Eye-tracking studies can show this in action as individuals view scenes and is therefore helpful in understanding topics such as wayfinding. This also tells us a bit about how we experience design features in a visual field. When items meet expectations, they show no threat and therefore go relatively unnoticed. Wayfinding within a city can be concerning when there are few identifiable objects to spatially locate ourselves within the larger cityscape.

The most important thing we can learn about the recall function is that it can be manipulated and exploited. We'll discuss culture in the following section, however, I'd like to bring up a few studies regarding how vulnerable our memories and associations really are. Memory is context-dependent. Not only because it is encoded with a context, it is recalled within a context based on stimuli within that environment in the moment.⁵⁰ Therefore, when events or objects are recalled, they are heavily influenced by what is around at the time of recall. Experiments have shown the power of these associations. In one experiment, it was observed that the type of music played in a store impacts the type of wine purchased. Subliminal marketing has keyed in on manipulation of associations and memories, so much so that the color of laundry detergent packages determine preferred brands by implementing memories in our mind. Preference is altered by recall functions. Even using specific adjectives to describe food menu options alters the way the food is reviewed.⁵¹

There was study done on a group of 20 individuals to show how suspect memory is. Each participant was selected because they had never been on a hot air balloon ride. Participants were told to bring an accompanying family member that researches would work with. The

accompanying family members provided researchers with multiple photographs that were used to create images of the subject riding in a hot air balloon. The subjects were then presented with the images as well as other images of the supposed hot air balloon ride. They were asked to look at the images for a short while then describe their experience of being in a hot air balloon. If they failed to remember, they were asked to close their eyes and imagine being on the ride. The process was repeated two more times at intervals of 3-7 days. By the end of the study, half of the participants recalled being on the hot air balloon ride.⁵²

Human memory is surprisingly corruptible. Simply saying the same thing multiple times is enough to allow someone to make the connection and forget the original source of the memory. There lies the ethical concern with monuments, culturally valued objects and image reproduction predicted by Nietzsche and Benjamin. Not only is it easy to falsify preference and recall in individuals, groups are even easier. When a memory becomes collective, its much easier for groups to adopt and significantly harder for a person to reject. When an arena full of people blame a specific ethnic group for their woes, you find it hard to convince yourself they aren't correct. Furthermore, studies show the same emotional mechanisms that are involved in physical pain are also involved in the pain of social rejection. This creates mental aversions to alienating yourself, even when specific judgements tell you otherwise. In fact, it has been shown that the anti-inflammatory acetaminophen, also known by the brand name Tylenol, can relieve social stress.⁵³

/ culture, cognition and consciousness

All of this adds up to a very interesting and powerful cocktail of aesthetic experience. We've got a portrait of context-dependent perception that distills experience into mental images that exist in the same capacity, whether it is the initial exposure, memory, knowledge or imagination. This sounds much more compliant with representationalism now that we've laid it out on paper however, we must not forget that realism focuses on the process. We've covered how the process of perception is dependent on context, including emotion, social evaluations, schema and subject to manipulation. It's a focus on this process that allows us to realize how vulnerable we are, so we can take ways to reduce exploitation. We must now come to understand the power culture has to exploit groups of people in a contemporary society. Culture doesn't provide the safety it once did. Where it once was advantageous to differentiate and discriminate, current society doesn't pose the same threats.

In 2018, Kwame Anthony Appiah published his book titled *The Lies that Bind*. He was fascinated with identity because he grew up the son of a man from the British colonized Gold Coast in Africa (now Ghana) and a woman from the English countryside. He was born in London but moved to Asante, Ghana at the age of one. Growing up in Africa with parents of different ethnicities and carrying a British passport, he was primed to question the idea of identity. Simplifying why we desire identity, he states identity gives you a sense of how you fit in the social world.⁵⁴ "Every identity makes it possible, that is, for you to speak as one 'I' among some 'us': to belong to some 'we.'"⁵⁵ Identities are built around what it means to be that certain type of person, whether its taboos or commandments that tell you what and who you are and aren't. Another feature of identities he highlights is that not only do they give you

reasons to do things, they give other people reasons to do things to you. Identities are the basis for hierarchies and other power structures.⁵⁶ An “important form of struggle over identity occurs when people challenge the assumptions that lead to unequal distributions of power.”⁵⁷ There’s two observations that can be made that highlight how identity issues are a recent situation. When populations were much smaller, and diversity wasn’t common, specific societal roles were important where knowledge was limited and life expectancy was much shorter. The occasional foreigner wasn’t as much of a threat because they were more an anomaly than a cultural presence. As populations grew and people began to move around, cultures had to accommodate other people’s way of life on much larger scales. Power structures were enforced on populations ranging from colonization to slavery. As societal pressures changed, designated roles were no longer needed and battles over gender equality, child labor and unions became common. Its easy to forget that in America, we are only 155 years removed from the emancipation proclamation, 98 years removed from allowing women to vote federally, and still fighting for civil rights and equality for minorities. In addition to sexual revolution of the 60s, we are still fighting for acceptance of gender identity and sexuality. This is all a very recent timeline considering the length of human history that is a product of population growth and development causing rapid lifestyle adjustments.

Simultaneously, these moments coincided with inventions that increased capabilities for division and political manipulation of populations. It ranged from printing technologies to telephone, photography, videography, internet and social media. These mediums allowed value to be applied to any context or object. Objects could be representative of a way of life. To Jacques Lacan, national identity was established by a relationship to a thing. Institutions are the back bones of cultures and these are manifested through physical objects. Whether it is a book, a monument, a building, a constitution or a ritual, it required something concrete to

establish and defend. National identity became a “belief in a belief.”⁵⁸ Lacan believed national identity could not be symbolized but must be perceived through an alternative symbolic structure that relies upon a fantasy of the homeland. Here is where the national myth comes in. We establish narratives to empower our cultural institutions. These narratives are attached to the objects we adopt. The best example of this is a piece of cloth we carry into battle. The flag can evoke enormous amounts of emotion, bringing some individuals occasionally to tears.⁵⁹ Just in the last two centuries, dozens of new countries were created, including Italy, Germany, and the majority of Africa following the collapse of European colonization. Countries like India, Ghana and Uzbekistan bound numerous cultural identities under a single flag and system of government. The United States was divided by the end of the 19th century and only civil war forced a unification. Residents of each state identify with both their state and country in addition to religion, industry and school district. Throw in gender roles, sexual preference and social media and its amazing we can keep our heads on straight. What makes this possible is how short our memory and historical knowledge is. Despite public education of history, we are contextual beings and remember only what is needed at the time it is needed and don't learn the lessons we should from historical events. Mythologies begin to change, and we fail to notice the altered narrative. It's an interesting study alone to observe how Catholicism and Christianity managed to change and stay relevant through centuries following numerous inquisitions, colonization, political wars, division of the Holy Roman Empire, corruption, persecution of scientists and so on. An institution has the ability to pivot its entire narrative to stay relevant and maintain power.

From a neurological perspective, we can easily observe how these tendencies exist in our faculties. Our predisposition for in-group and out-group behavior is observable in most of our behaviors and documented scientifically. Our favoritism for our in-group fuels ethnic

homogeneity and creates boundaries between ourselves and others. It does more than just give us something to label ourselves, it fundamentally changes the way we think.⁶⁰ Studies show that racial dichotomies are formed during early development when we get accustomed to our parents' race and those we grow up around. Children form these biases without negative intent. It takes very little sensory stimuli to form differences and formulate expectation and behavior. It is interesting to note that typical *us vs. them* division involves an inflation of our values as opposed to a deflation of others. Our buildings are better, our food tastes better, our music is better. These are things we tell ourselves to strengthen our identity and think higher of ourselves. In fact, seeing members of other cultures has the ability to activate the *insular cortex* which normally is activated in response to disgust for tastes or smells. We all have been repulsed by an image of something in our lives, this is a common thing in human beings when seeing those different from themselves. There is a saving grace here, we have shown a propensity to feel guilty about most of these divisions and try to conceal our innate bias.⁶¹

When we foster strong identities, we draw stronger lines between each other. As Robert Sapolsky puts it, "people are willing to kill or be killed over a cartoon, a flag, a piece of clothing, a song. We have some explaining to do."⁶² Despite movements questioning identity such as the LGBTQA or Black Lives Matter movement, groups fly flags of support and fight for recognition of their group and acceptance of their presence. The paradox here is by defining ourselves, we only divide ourselves. In our efforts for equality and resolution of injustices, we demand treatment based on our specific group. This shows very important aspects of identity. Its evolutionary role is prevalent and probably won't go away anytime soon. This can be seen with the fluidity we have to reestablish identities on the fly; every time we open our phones, depending on the app we open, we are a different personality. We say things in groups of

friends we don't say in groups of professionals, then we say completely different things on dating websites and in front of our parents. Depending on who is in the room, the platform we are on or the anonymity of our medium, we fluidly change from one identity to the next.

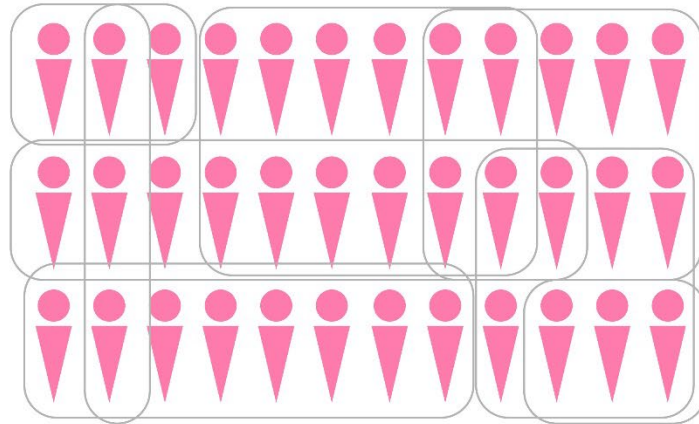

Figure 22: we all exist in multiple in-groups at any given time and take on the persona of whichever is most contextually prevalent (diagram by self)

Architectural objects aren't removed from any of these equations. Culture and identity don't just change how we see things; they change what we see. But it isn't an alternate reality, it is a product of a process that we should be aware of. When styles become ideologies, they come to define a group of people. At this point, it becomes a friction between cultures. When we form our cultural schema, we respond negatively to variations of it (see figure 23). Then we attribute emotion to specific objects that impacts the associations we make during perception.

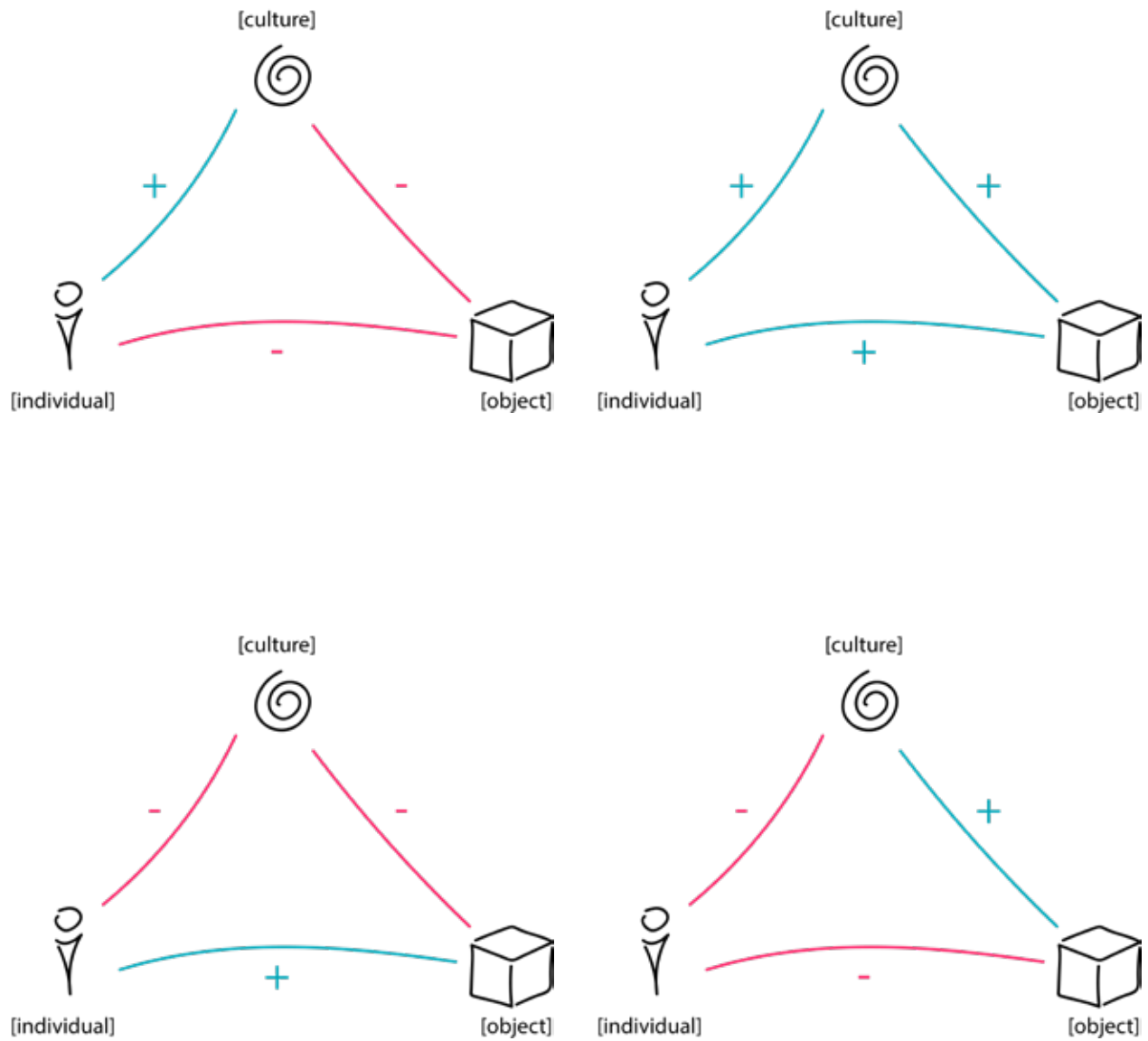

Figure 23: Franz Heider's balance theory was based on a simple relationship between an individual, their reference state, and the object of reference; here we see four examples of relationships where how an individual feels about a culture dictates how they feel about an object that relates to the culture.⁶³ (diagrams by self)

All of this impacts hormones and receptivity. At the same time, habituation works to bore us of our environments, so we have internal conflicts between conservatism and desire for new experiences. These cognitive processes shape how we treat each other, and objects are fundamental in the formation of these perceptions.

That being said, our awareness of the process has one more argument to make. Some scientists believe we are aware of only 5% of our cognitive function.⁶⁴ Others believe consciousness has absolutely no impact on behavior. Psychologists David Oakley and Peter Halligan use the metaphor of a rainbow to describe consciousness. A rainbow is not a tangible object. For centuries, cultures mythologized them being unable to explain the phenomena. Modern science answered the question and realized what was being seen was just light passing through moisture. A rainbow is just a projection caused by physical processes. More importantly, its existence has no impact on the processes that bring it into reality. To them, consciousness is the rainbow, a projection that has no impact on what brings it into being (see figure 24).⁶⁵ Regardless of who you side with on theories of consciousness, what is agreed upon is that most of our experience is non-conscious. The aesthetic arguments we wage are products of processes outside of our conscious control. This is the fundamental importance of learning more about how humans respond to environments. If we aren't capable of directly observing ourselves, but capable of directly observing others and learning from empirical data, we can form arguments from knowledge and not emotion. The poetic language that targets our emotional states brings beautiful experiences and wonderful connections to our intuitive side, but it also clouds judgement and persuades others through emotional manipulation. This is the paradox and pitfall of identity and culture. Our conservative comforts, desire for advancement and ability to make value judgements for

advantageous behavior give us all sorts of obstacles to equality, freedom and genuine diverse experience.

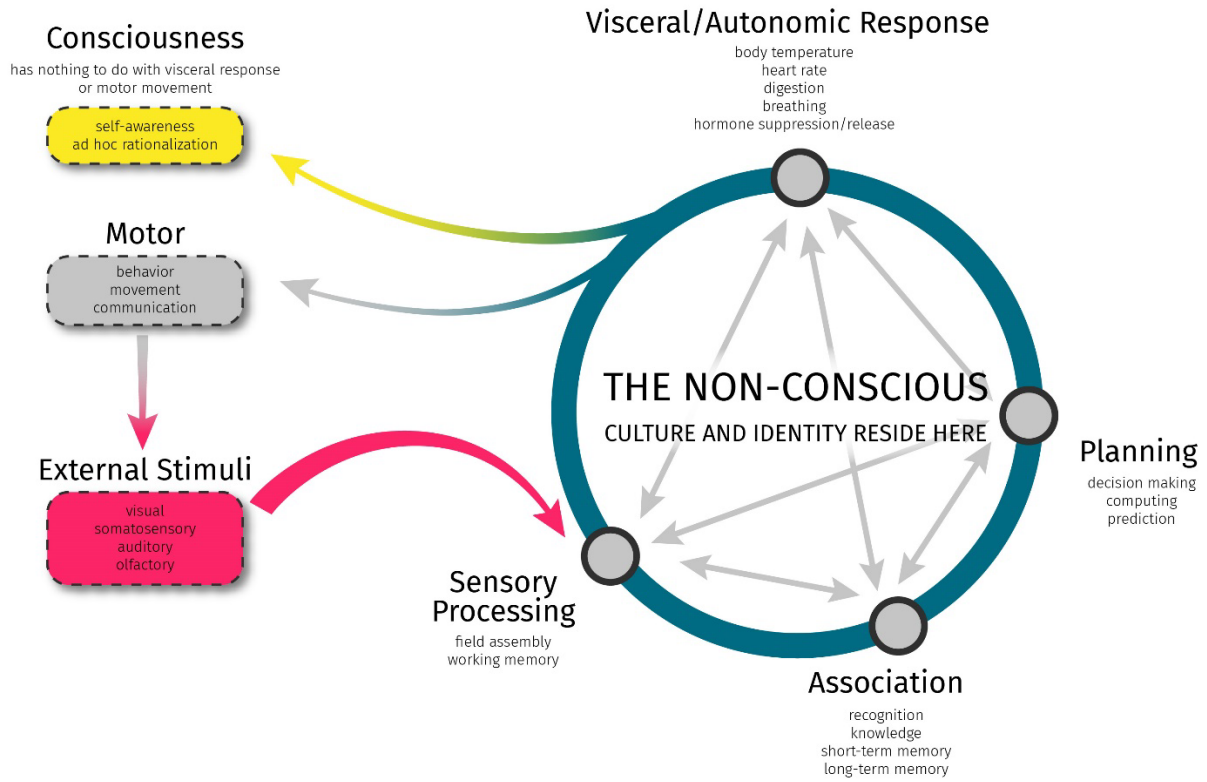

Figure 24: this diagram shows recent theories about how consciousness factors into behavioral responses; some present-day scientists believe consciousness is on a representation of non-conscious processing and doesn't impact the process at all. (diagram by self)



LESZUMER

from the Peter Zumthor designed
Kolumba Museum in Cologne
(image by self)

what can you do?

For architecture the conditions have changed more in the last thirty years than they changed in the previous two centuries, yet we still act as if it's the same profession. There have been radical changes to so many things, such as computing power, engineering and the relationship between architect and client, yet we persist as if we are still old pipe-smoking gentlemen.

-Rem Koolhaas¹

Now that we've been exposed to these realities and potentials, we must discuss what we can do with them. I'm going to spend a second trying to describe something we don't have good words for. Try to remove yourself from the typical definitions of the words new and create. For the following paragraph, define new as something that there is absolutely no precedent for, whatsoever. Not just something you haven't seen before, not some assemblage of objects or anthropomorphic being. Something that looks unlike anything you have ever seen or heard of. If I asked you to picture what *Shewanella Benthica* is, with exception of a few specific professionals in a given field, I guarantee what you pictured is something you are familiar with. You have probably constructed something out of all known images you've seen and depending on how imaginative you are and the connections you made, it may look very abnormal. My

point here is that there is nothing about what you pictured that can't be somewhat tied to something you've seen or heard of before.

There are two important observations we are making here. The first is everything you can imagine comes from something you have experienced before. This is because your brain perceives thoughts through existing patterns and connections within the brain. What you consider new thoughts or creativity is merely just an assemblage of existing knowledge.

Designers are merely composers, taking given information and assembling it in creative ways.

The second observation and most important: since everything we can conceive of is from existing connections in our brain, the more we are exposed to, the more possible outcomes there can be. There is an extreme importance to diversity. We all understand a diverse team brings more ideas to the table, but we often fail to remember that diverse experiences widen our minds as well. Here is the fundamental argument to breaking the chains of conservatism so we can better our chances of solving problems. Diverse environments, whether it is cultural, built or social helps open our minds to change. This means, but certainly isn't limited to, accepting and developing new tools, ways of practice, organizational methods and utilizing new skill sets in seemingly unrelated fields.

Numerous architectural theorists have argued their ways of doing things and rebuked each other. It's important to understand that none of them are right, nor what I'm saying here is right. They are just ways of designing that build upon what comes before them. It's up to us to use the tools we are knowledgeable of to help push this profession further. The key word is exposure. All specific methodologies aside, the single most important action you can take is to seek out as much exposure to ideas, technologies and other methodologies so you can foster a culture of learning in your office, studio or life in general.

/ it's already happening

If you are still on the fence, let's start by acknowledging all the work that is already going on that brings in empirical research and technology in design. In 2003, the San Diego chapter of the AIA founded ANFA, the Academy of Neuroscience for Architecture. The academy brings together scientists, architects and educators to further understand how architecture impacts the human body. Scientists with the Salk Institute along with researchers across the country and designers come together to inform decisions and policy related to the built environment. The academy hosts conferences, curates a database of research and puts out calls for papers and publications.² With strong ties to ANFA, the NewSchool for Architecture in San Diego now offers a master's degree certificate for neuroscience in architecture.³

Seattle based firm NBBJ is part of the vanguard in the field of neuroscience and architecture. The firm collaborates with molecular biologist and University of Washington faculty member Dr. John Medina to better understand the impacts of their design and to better health of individuals and organizations. They've used behavioral science to increase productivity and problem-solving capabilities by integrating acoustic strategies and biophilic design in office environments such as Amazon's downtown Seattle headquarters. The science also justified design decisions that provide visual respite, calming scents, encouraging movement and access to healthy foods.⁴ Dr. Medina encourages designers at NBBJ to incorporate features that remind us of our early evolutionary tendencies from our time as nomadic hunters and gatherers. He believes tying in our Darwinian reflexes provides respite and energy in

workplace environments. He is a big supporter of Jay Appleton's prospects and refuges theory that we'll discuss shortly.⁵

The architecture firm Perkins+Will hosts one of the industries largest research practices including their Human Experience Lab. The lab is lead by Dr. Eve Edelstein who carries a Master of Architecture degree and a PH.D. in neuroscience, is co-founder of Clinicians for Design and serves on the board of the ANFA among other notable roles. She works with other Perkins+Will researchers like John Haymaker to develop an evidence-based practice by integrating studies in lighting design, interior environments, and acoustic design that foster mental, emotional and physical well-being.^{6,7} By utilizing studies in daylighting, they integrate design strategies to better immune and endocrine functions in healthcare environments to combat seasonal affective disorder, reproductive and growth disturbances, premature aging and negative affects on memory and cognitive activation. They've used research that shows individuals exposed to more sunlight required 22% less pain medication, reducing needs for drugs and overall cost for patient and facility.⁸ Their Material Performance Lab uses empirical analysis to justify the use of healthy materials.⁹ They also curate a public list of product and material disclosures on their Transparency website that provide designers empirical data to educate clients and each other of negative health effects in the built environment.¹⁰

Another Seattle based architecture firm, NAC, utilizes empirical data to better inform design decisions for education and healthcare environments.¹¹ Their research and information department, known as NACLab, shares articles and research done regarding architectures impact on memory, agitation, social interaction, biophilia, and living environments.^{12, 13} Corgan performs their own studies on eye-tracking to better understand wayfinding within airports to inform design decisions that provide insights into cognitive mapping.¹⁴ Architects at Woods Bagot are merging artificial intelligence, spatial cognition and data spatialization to offer

consulting services related to spatial analysis, behavior mapping, algorithmic design and research.¹⁵ These are just a select few examples of architecture firms incorporating evidence-based design and studies in the science of human experience. In addition to this, numerous firms are using widely available tools for studying daylighting, energy use and thermal comfort in buildings.

In addition to efforts by architects and researchers, many building regulations and certification organizations are using behavioral and biological research to establish design requirements. Danish building regulations will require a 15% glass to floor-area ratio in future building codes.¹⁶ The Building Research Establishment Environmental Assessment Method, BREEAM, requires 60-80% of building area to meet minimum daylight factors requiring average daylight illuminance of 300 lux for 2000 hours a year or more averaged over the entire space (variations depending on area type).¹⁷ In a recent publication, architecture firm ZGF's Martin Brennan and Alex Collins produced a paper providing methods of meeting the WELL Building Standards lighting requirements. WELL requires a daily minimum of 200 melanopic lux between 0900 and 1300 to meet circadian rhythm demands.¹⁸ LEED specifies average reflectance values for floor, ceiling and wall surfaces in addition to minimum luminance values.¹⁹ LEED also requires environmental impact statements and material disclosures for interior finishes based on empirical research regarding effects of interior environments. By reducing *volatile organic compounds*, VOCs, damage to occupant health is reduced.

This is just a small list of the amount of work going on in the profession related to human health and experience that utilizes empirical analysis and scientific studies. We can understand not just behavioral health, but degradation of DNA and impacts on cell reproduction. We have numerous studies now relating light qualities to hormone secretion,

mood and focus. Studies on restorative affects in visual fields provide us further justification for biophilic design and programmatic use of natural areas. Landscape researchers in one report used eye-tracking devices to understand where individuals looked to take visual breaks from stimuli within environments.²⁰ Evidence based design is a rapidly growing force in the industry and it should be fundamental for designers wanting to make an impact in their communities and with their clients.

/ apply the science

The easiest way to apply these is encouraging the use of empirical studies. Many architectural conferences put out calls for papers that introduce designers to various research being done. University departments on behavioral health, vision and cognition, neurobiology, endocrinology and environmental design have large databases with access to decades of research on how the environment impacts individuals and groups. A single scientific study can form an entire design concept that challenges industry practice and furthers development in experience and health. There are many case studies that can be applied to design. Building product and systems manufacturers and distributors often provide case studies that exemplify sustainability and occupant impacts.

Firms like Perkins+Will²¹, NBBJ²², Woods+Bagot²³, Kieren Timberlake²⁴, NAC²⁵ and ZGF²⁶ (just to name a few) have open source blogs that share research on human experience. UNStudio has a research arm called UNSense that investigates the future of architectural experience and

technology.²⁷ There is a wealth of resources available and a growing community of contributors helping further the profession through collaboration and open sharing of ideas.

/ measurements

To utilize evidence-based design, architects are tasked with creating some measurable parameter. In fact, any designer should be accustomed to goal setting which requires accountability per measurable means, the same needs to be applied to architectural design and aesthetics. There are numerous ways to turn observable patterns into quantifiable data for analysis. I'm going to briefly highlight a few surveys done on aesthetic preference in the built and scenic environments, then discuss a preliminary study I performed to understand better how this process may work.

In 1969, Robert Hershberger performed a study in aesthetic quality that assessed architecture students from the University of Pennsylvania and Drexel University, pre-architecture students and non-architects. The goal of the study was to evaluate the qualitative meaning of architecture across these four groups. The author surveyed each group on qualities of a space in three categories and had them rank each evaluation a scale of seven, from strong to weak. The first was a space evaluation that included qualities such as cheerful, delightful, spacious, pleasing, good, interesting, comfortable, beautiful, exciting, unique, active and revolutionary among others. The second category was organization. In this category, participants were asked to rank the space regarding order, clarity, rationality, simplicity, control, and straightforwardness. The final category was aesthetics, potency and excitement. Some of

these qualities were bold, strong, unique, rugged, profound, pleasing, ornate, controlled, delightful and interesting. Each category was factored using statistical methods and evaluated against each other. There were specific qualities that drew contrasts between specific groups but overall, the study showed little difference between the groups, leading the author to conclude that there is no fundamental reason not to believe physical attributes constitute a “code” that designers can apply to aesthetic intentions. This begins a foundation of understanding that across groups, spaces are evaluated much the same with occasional specific variations that could be attributed to knowledge base or culture.²⁸

Hershberger performed another survey in 1974 with Robert Cass to create some predictive measure of user response. Again, the authors used a scale of seven rating specific qualities of space. Participants were shown slides of prototypal housing on five different media types (two types of slides, two types of film, and one type of video). A few of the qualities they ranked were beautiful/ugly, interesting/boring, profound/superficial, ornate/plain, ordered/chaotic, unique/common and exciting/calming. The process created was used in a consulting role where client’s employees were surveyed prior to design to better understand the features that most related to the predicted responses. Sadly, I have no images of the buildings these surveys produced, however this provided another step in understanding how users respond to certain design features and developed a predictive approach.²⁹

In 1983, Linda Groat performed a study investigating whether style or personal taste affected a participant’s assessment of contextual compatibility. More clearly put, she was trying to figure out if taste had anything to do with how contextual a building appeared. She did this by selecting work specifically from periodicals where the work was reviewed. Participants were divided into two groups, one of experts and the other of non-experts in the field of design

review. The results echoed previous studies, such as the previously mentioned work of Hershberger, that assessments were consistent across groups. This meant that personal taste did not affect aesthetic assessment of contextuality. Architectural literature was shown to over play the difference between contextuality judgements of the projects selected. Other results showed a preference for repetition of façade elements that highlighted the importance of small-scale design features. The final observation from the author was that architects must focus on “evolutionary – rather than revolutionary” design.³⁰ However, I’d personally shy away from that last statement given preference wasn’t necessarily a focal point of the study and it seems a little personally motivated.

A series of studies from 1984 through 1990 performed by Douglas Amedeo and Ruth Ann York focused on participants’ perceived emotional responses to environments given norms, social pressures, emotional predisposition and response to environmental schema. The authors had two overarching hypotheses. The first is that an individual’s response is not due to differences in physiological reactions, but a result of cognitive processes. Essentially, they were arguing that we commonly focus on the result and not what caused it, which was cognitive processes. The second is that how people describe their responses is the result of *cognitive appraisals*.³¹ The first study in 1984 was focused on establishing norm influences of everyday environments. Three scenes were used, one of an urban street scene with an older aesthetic character, a social gathering scene that appears to be in an office setting and a woodland setting that featured trees and a flock of geese. The images were projected and participants were tasked with imagining being within the scene and rate thirty-two different qualities on a scale of 1-7, 1 being the lowest. Qualities included enjoyment, nervousness, boredom and anxiety among others. The results yielded multiple observations, the first being that each scene appeared to produce a normative response from participants. Another is that, when asked how they’d rank

the same qualities if someone they new was present with them in the scene, the responses became more pronounced. This would seem to say that social situations reinforce norms regarding experience. Having someone present also showed that in the social gathering scene, perceived experience became more pleasant and assessments showed less apprehension. This is probably the result of having support within the stressful social scenario. The conclusion by the authors was that people have access to emotional norms and one could assume there is a “feeling-rule schema.”³²

This led to their next studies published in 1988 and 1990 that analyzed affective experience and cognitive processing during activity within environments. The goal was to establish how affects like or emotions might alter, modify or guide perception and behavioral outcomes in person-environment-behavior relationships. The results concluded that it is plausible emotional states impact experience in relation to norms, stereotypes and schema. The fundamental observation here is that emotional states alter retrieval cues and determine accessibility to mental contents during cognitive processing.³³ The previous studies mentioned are a very small representation of the body of research done regarding human experience. Each of these studies alone references dozens of other studies on the topic that predate them. There have been many more since that have also tackled experience and the environment.

After studying these methods, I was encouraged to undertake my own preliminary study of aesthetic preference. It’s clear now that I underestimated the amount of work it takes to develop a hypothesis, develop a method of surveying to test it, then interpret the information. The skill involved in creating a survey and administering it alone is quite the undertaking. Additionally, you need a good amount of knowledge in statistics and survey methods to accurately conduct a survey. Suffice to say, I had no background in any of those fields so

alone, the information I was able to gather was limited. My goal from the start was to see if I could find some correlation between conservatism and aesthetic preference. The fundamental idea was that a form or environment that was more foreign to an individual creates more potential stress. Furthermore, the more conservative an individual is, the less accepting they are of new experiences. A cursory review of over 100 responses supported the studies mentioned earlier that there wasn't a discernable difference between groups of individuals. In fact, there is hardly any discernable correlation between the conservatism factors generated and participants preference. In testing for conservatism, typical questions were used regarding trust within and outside of your community, importance of traditions and self-disclosure of cautiousness. The survey was administered online and provided nine images. Each participant was tasked with selecting the two most-qualified and two least-qualified images for each characteristic. The characteristics asked were appeal, complexity, uniqueness, representative of current culture, preference and memorability. The study was done on both interior and exterior spaces. I believe where this study may lead me is to further investigate a quantitative factor of stimuli in relation to preference but only after further rounds of preliminary studies and interdisciplinary collaboration. Given the amount of work it takes to review and interpret the data, further work will need to be done before any worthwhile conclusion can come out of the work. It is my hope that I can take more time after this document is finished to review the data and turn the preliminary study into something more productive.

I want to mention one more study before moving on. This one was done in 2017 by a team of individuals, including a noted researcher of neuro-aesthetics, Anjan Chatterjee. This study sought to find preference between curvilinear versus rectilinear spaces. The study provided images of various spaces to two groups, one of experts and another of non-experts. The

images were evaluated on two parameters. The first was beauty and the second was willingness to enter. In all groups and both parameters, there was a preference for curvilinear spaces. The authors believed it is possible our preference for curvilinear spaces can be tied to our sensorimotor systems. The other explanation they discussed is the preference may arise from the demand for an appraisal-based response, meaning the curvilinear form is experienced in a nonrepresentational manner what can implicitly or explicitly elicit emotional evaluations. The research has much left to prove but highlights something that goes contrary to the bulk of our designed spaces.³⁴

Numerous other methods exist for quantifying and measuring experiential qualities in space. Programs such as Ladybug and Honeybee, plug-ins for Grasshopper and Rhino, allow use of weather data to analyze comfort parameters, energy use and production, and lighting analysis. Light meters can be used to study a space and its qualities that will allow you to create useful daylight maps and false color analysis of light levels. The software then can help redesign the space to meet the new parameters. Glare analysis can be done for visual comfort that can impact eyestrain, stress, cognitive mapping, productivity and comfort. Programs such as Lark can help analyze impacts on circadian rhythms. Other mathematical tools and spreadsheets are available that can help turn photopic and scotopic data into melanopic lux to meet specified certification requirements.

Eye-tracking is another tool that architects can use to investigate how subjects behave in environments. It can be used in existing environments to test hypothesis or collect data. It can also be used on images such as project renderings and drawings to help understand what features are standing out to observers. Currently, companies are working to combine eye-

tracking technology and virtual reality headsets that could allow clients to move around within 3d models and inform designers to where they eyes go.

Space Syntax is another proven method for analyzing space and behavior. A study of the Seattle Public Library was performed to understand how programmatic adjacencies and visual occlusion created the designers desired experience. Space Syntax was developed by Bill Hillier and Julienne Hanson in 1984.³⁵ There are four components to Space Syntax. First is representations of space. This is a geometric and relational analysis of point, axial, line, segment, convex space or isovist. Isovist is a form derived from all points visible from a given vantage point. Another method of representation is analysis of function. The second component is spatial relations. This relates to both integration, ease of access to desired destination, and choice, which measures passing flow. The third component is interpretive models. These are models to analyze and forecast spatial and socio-economic phenomena. And finally, the last component is theory. This last step is the application and establishment of a theory.³⁶ To simplify, what is looked at is spatial relations between an observer and a space that investigates how they will formulate their goal and move towards it. It is much in line with thought regarding spatial cognitive mapping and how humans move about space and know environments. The analysis resulted in an understanding that the designers intentionally created dissonance in wayfinding by providing one-way movement vertically into the library spaces. By not providing a return path along the same route, users had to traverse and engage with the building and spaces.³⁷ This was intentional by the architect and created what Guy Debord would call a *direct experience*. It also would be described in the terms of Bill Brown's theory of "Other Things" previously mentioned in this thesis. The image below is a diagram of typical library configurations. Following that is a figure of the Seattle Central Library designed by OMA that shows how the designers used movement to engage occupants

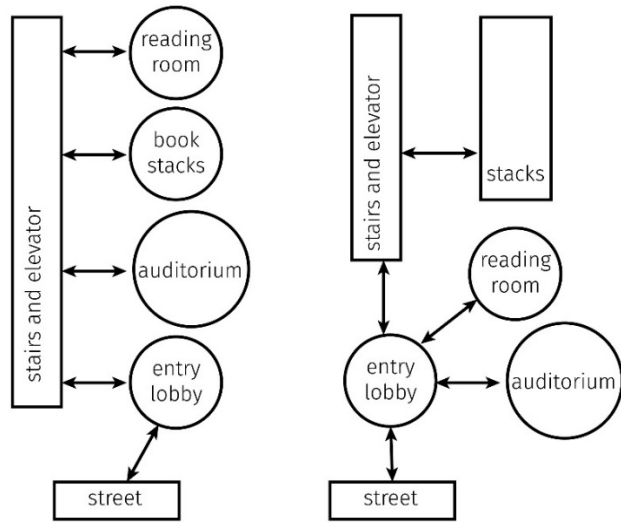

Figure 26: typical library spatial configurations with controlled access (diagram by self)

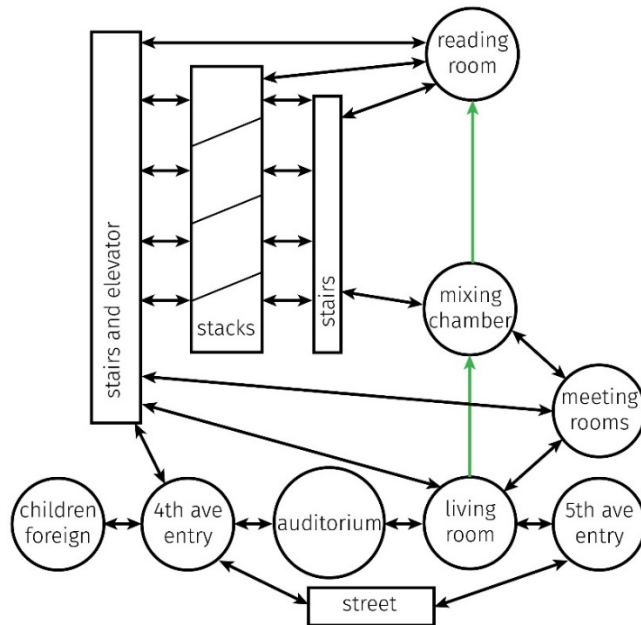

Figure 27: spatial analysis of the Seattle Public Library showing how movement requires engagement with the architecture and other occupants (diagram by self)

with the space. Rem Koolhaas also uses this approach to break with the perception of a control society and provide freedom to users by removing the psychological constraints of secure entry and exit points. By allowing movement outside of normal control measures, users are given a sense of control and liberation.³⁸

Another method employed by designers of the Seattle Central Library was an early version of what UX designers call *personas*. This is an analysis that creates specific characters with given traits and specified goals then gamifies their movement throughout the building.³⁹ There is much architects can learn from UX research and designers. Designers of software interfaces, websites and apps often use tools such as eye-tracking, personas and user engagement to better understand how their design impacts behavior. This includes color theory and contrast studies, accessibility, graphic movement and complexity. A lot of their research also includes surveys and focus groups. The big difference is they use computational analytics and process large amounts of data using machine learning and artificial intelligence to better understand our needs and desires. Architects should branch out and understand how designers of other products, especially in the digital world engage human behavior.

/ design intelligence, reflexivity and whatever happened to criticality

In his book *Modern Architecture: a critical history* Kenneth Frampton laid out his framework for a *critical regionalism* that was centered around protecting conservative comforts while fostering contemporary criticality. The emergence of regionalism was a product of centrist international styles that were often devoid of local spirit. Designers sought an independence from universality and focused on local and national aesthetics to foster a cultural essence and

established identity. Much like Leach spoke of camouflage, regionalism became the designer's interface with society. This was not a re-emergence of the vernacular, but an evolution of modernism and locality.⁴⁰ Frampton:

The concept of a local or national culture is a paradoxical proposition not only because of the present obvious antithesis between rooted culture and universal civilization but also because all cultures, both ancient and modern, seem to have depended for their intrinsic development on a certain cross-fertilization with other cultures.⁴¹

Much of fashionable architecture falls somewhere between globalism and regionalism with one catering to a more collective future and the other clinging to more isolationist tendencies. Frampton's intent was one of admirable criticism and based on historical mistakes by many modern architects. He saw clearly the failure of modernism to account for local culture and that this identity was functional and essential to human behavior. And to his credit, this may have been very needed in his time and place. However, regionalism is taken to its extremes in times like today where social media and journalists clamor for defining themselves in an over-saturated world.

Things such as national identity rely on values being imprinted in physical objects that embody our institutions and beliefs. Neil Leach covers this topic critically stating populations need to "read itself into objects in the environment in order to articulate" national identity.⁴² He relies heavily on the theories Lacan when establishing his understanding of national identity. To Lacan, national identity couldn't be symbolized and could only be perceived through an alternative symbolic structure that relied on fantasy. Groups had to develop what he called the "myth of the homeland." This wasn't a belief, but, similar to religion, was a

“belief in a belief.” Identity becomes a lifestyle that is reinforced by the objects we project ourselves upon.⁴³

Returning to Frampton, he uses many examples of architecture that have come to signify the cultures they promote such as Luis Barragan, Mario Botta, Tadao Ando and Sverre Fehn. All of these architects are profound and greatly influential, creating and influencing some of the more memorable experiences I’ve had in architecture. However, where critical regionalism promotes a modernist critique, it also promotes a strong regional identity. It reinforces conservatism and provides an ideology for design. If we were to use the political spectrum as metaphor, you’d say critical regionalism is just right of center, a little more conservative than the moderates. Where this becomes a problem in the information age is the proliferation of images. Periodicals are sent straight to our phones and computers. Media uses emotion to draw viewership and raise profits. We live in a world where a click on an internet page generates revenue for a business and increases advertisement real-estate value. The easiest way to do this is by playing on individual’s emotions and fears. It’s not long before critical regionalism journeys into the extreme realms. We see organizations built up around preserving even the most run down, inefficient and obsolete buildings under perceived threat that their way of life is being taken from them. Efforts to combat global warming meet the same resistance, where a resolution to the problem requires a change in lifestyle. This affront to someone’s “belief in a belief” is an easy tool for profit in a capitalist market and individualist society. Conservatism provides us much needed comforts in an ever-changing world, but we have abilities to adapt to increasing stimuli and stress. History shows that conservative values get more liberal as time progresses because we adapt to global and social



from the Rhode Island State Capitol
designed by Mckim, Mead and White
(image by self)

pressures. Change is inevitable, conservatism just slows it down so we can more comfortably function within our society in transition. It's a way of reducing stress.

Beginning in 2002, Michael Speaks began articulating his theory of design intelligence. His critique began with modernism's efforts for certainty and truth, focusing on sciences and an embrace of universality. The first industrial revolution brought intelligence into tools and following the second world war, intelligence was brought into management and development. Entities of power were no longer bound by national constraints and power began to decentralize. Globalization gave competitive advantage to international corporations, criminal organizations and intelligence agencies.⁴⁴ Political and scientific truth as he put it, "have fragmented into proliferating swarms of 'little' truths appearing and disappearing so fast that ascertaining whether they are really true is impractical if not altogether impossible."⁴⁵ We found ourselves in the post-truth world. Our current president claims there are "alternative facts" and media outlets reporting the same thing have vastly different stories. "Critical architectures" of the 60s and 70s were "stylized simulacra" that failed in similar fashion as the international style it criticized according to Speaks. It lacked the political gravitas of international modernism. Post-modernism, deconstructivism and critical modernism failed because they were in a cycle of constant critique, stuck in a realm between criticizing the before and the emergent world of uncertainty in the after. He draws a line in history at the September 11th, 2001, where the world of intelligence changed. The post-9/11 world was one where centralized intelligence couldn't compete with global networks. We were forced to abandon cold-war isolationism and share intelligence to match the advantage of more agile networks.⁴⁶

This ushered in what he called “design intelligence.” He establishes in an insight provided by Gilles Deleuze regarding bodies. A body could be anything, a body of water, an animal or any mass of some material. Bodies have agency to effect change only dependent upon their capability to be affected by their environment. He applies this to the idea of architectural practice as a body with the same principle: capability to be affected gives agency to effect change. The framework this establishes is an architecture based on intellect, adaptable and fluid enough to capitalize on networks of information and keeping pace with developments. His examples are Foreign Office Architects, OMA, UN Studio, SHoP Architects and landscape group Field Operations led by Stan Allan and James Corner.⁴⁷ These designers opened themselves up to being affected by their environment by not bonding to a stylistic code, but by interpreting the context. This receptibility forces them to readjust their “resting speed, creating, in turn, a more complex, variable arrangement” that allows them to be “more adaptable and more competitive.”⁴⁸

Arie Graafland provides a critique of Speaks system, but not an outright rebuke, more of a consideration and expansion of ideas leading to his own theories. Graafland takes and understanding of Speaks’ design intelligence theory and reestablishes the critical thinking within through new terms. Where Speaks believes the critical to be gone and remaining is an instrumental theory of adapting and responsive practice, Graafland argues that critical theory is replace with reflexivity and still exists in both practice and educational institution. What Graafland promotes is titled *reflexive architecture*; one that is focused on the mutual benefit institutions and offices offer each other in exchange.⁴⁹ Reflexivity is mainly a product of academia. Practicing architects get their information and inspiration elsewhere, from their own work, publications, site context, regulations and other people’s work. Architecture is understood as a *culture industry*, an industry built around developing or reinforcing a culture.

Where practice is bound to these limits of inspiration, universities are where “different interests and ideas have to work together or at least tolerate each other.”⁵⁰ Graafland proceeds to share Scott Lash and John Urry’s commentary on culture industries, specifically music. They argue that cultural artifacts no longer act as transcendent representations but reduced to mere cultural objects. They no longer signify larger ideas but only themselves in a culture of exchange.⁵¹ In this sense, architectural ideas are no longer ideologies, but material objects amongst other material objects. The postmodern society has moved from ideological lifestyle to a lifestyle of materialism. This is something we know of as object fetishism, materialism and consumerism, a world where the objects we possess construct our image and identity. Graafland ties in Neil Leach’s theory of “architectural anaesthetics” and the digital proliferation of the image.⁵²

Graafland interprets Bruno Latour to combat Speaks. Speaks believes design intelligence deals with everchanging contexts where we must use what we can to respond at the given moment. Latour believes we should work to get closer to facts and use empiricism and realism to address our concerns. Instead of dealing with facts, we should focus more on what caused them.⁵³ Graafland then describes a redirection to what he calls *architecture of the street*, “a reflexive architectural way of proceeding, renewing empiricism, and addressing the sophisticated tools of architectural deconstruction and its inherent construction – or better, the lack of – social construction.”⁵⁴ The end result is a critique that doesn’t rebuke, but assembles, and is not negative, but productive.⁵⁵

What both Graafland and Speaks write about is a changing environment where network theory becomes the new norm and we must adapt the way we practice to remain not just competitive, but productive. Organizational structuring of research and criticality aside, the focus here

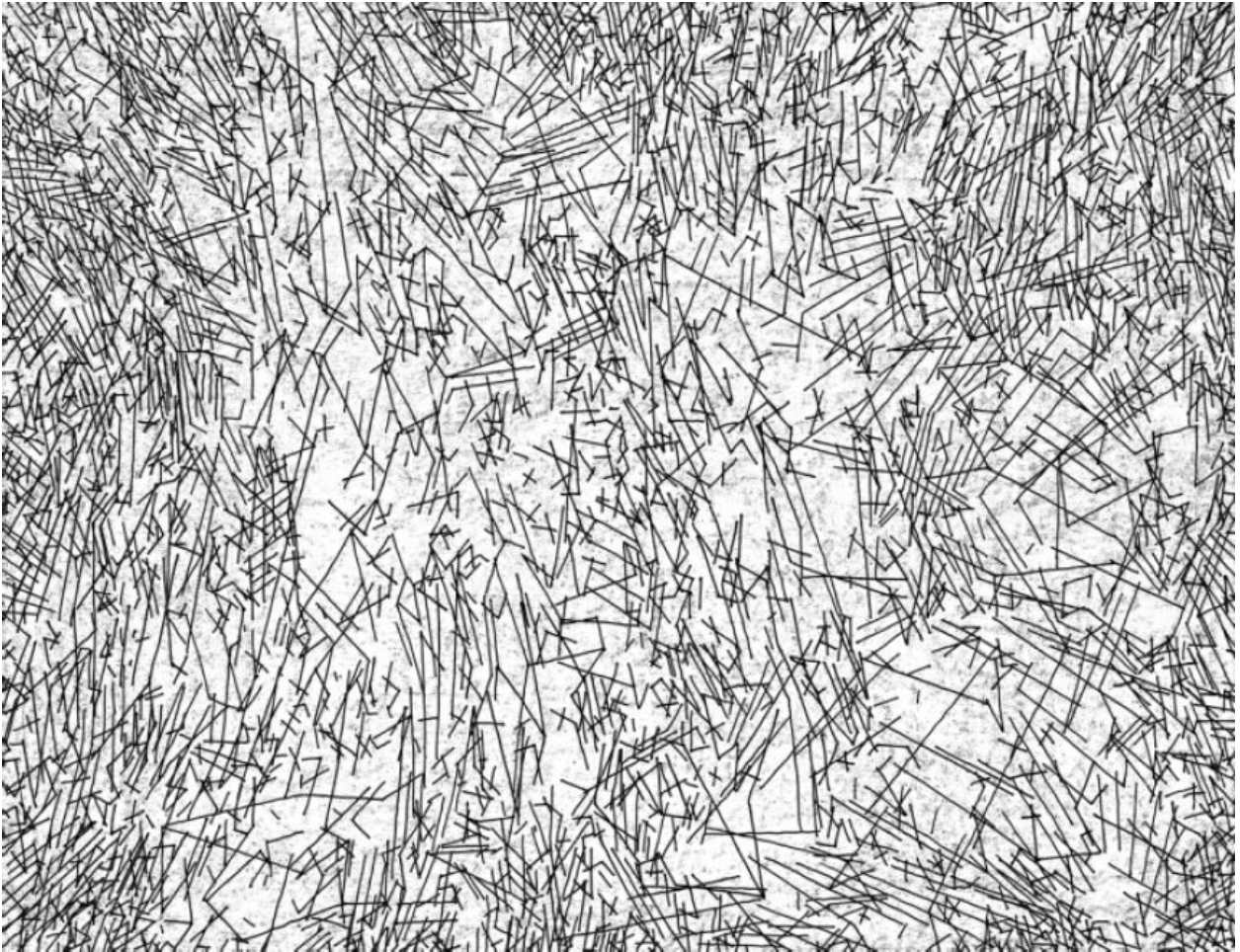

Figure 28: field conditions by Lebbeus Woods⁵⁶

should be on adaptability and empiricism, not treating symptoms but using our tools to address the causes. They both speak of a flattening culture now based on the aesthetic object and how industries of culture develop around rapid consumerism and fluctuation at global scales. Both theorists wrote these essays prior to 2006 and since then, social media has exploded not just in the United States but across the globe. Since then, there has no doubt been an identity crisis predicted by many. In 2009, Lebbeus Woods wrote a blog post titled "Same Difference." He focused this article and a series of sketches based on the idea that our generation will have to solve the seeming paradoxical globalism and individualism. We fight on social media to establish ourselves amongst others, either combating or accepting anonymity. Woods sees a world where designers and architects need to redefine in visual terms our global field condition.⁵⁷

If we take all we have learned and discussed up to this point, we can see a noticeable pattern in how we develop and understand ourselves within an environment. We see that there is an evolutionary necessity and functionality to identity that ties directly to how we perceive ourselves in space. From the mirror stage, and possibly even before that, we establish a critical self-awareness that allows us not only to establish ourselves against a given back drop (the environment), but to help us discern objects of threat and necessity. There are built in systems that work inline with network theories, spreading energies through synapses and initiating physical reactions to physical stimuli. Visual input is provided as light energy that our body can respond to dependent upon its wavelength and our biological capabilities. Pressure applied to our skin alters charges in our nerve cells that send signals up the spine and into our brains. Our brains process these patterns and relate them to previous patterns of similar inputs through tens of billions of brain cells and seemingly infinite number of possible signal combinations. In addition, certain patterns cause hormone release that alters

responses. To get this more tangible, there are more than ten times the amount of braincells in your head than there are humans on this planet. That accounts for some serious computing power, computing power that we can visualize and analyze with technology that improves by the day. To add to our power, we have computers that can greatly extend our abilities to recognize patterns and better understand causality. Speaks is correct about our fragmented nature of experience with fleeting moments of facts demanding prompt responses that we are only so able to approach. This requires a major organizational change to how we operate as architects to capitalize on a world of design intelligence. However, Graafland is correct in understanding how culture factors in to this and our abilities to work together in this network of information to influence and inform with more empirical data. The architect as a consultant in the cultural industries has power to bring together numerous experts and tools to understand who we are designing for. Ideologies are breaking down as identities are anesthetized by material culture.

This introduces yet another, new kind of criticality, one that questions what we are, not what we've done, nor what we want to be. A design theory that considers who we are and how we are. If identity isn't simply which style we like, if it is a product of processes that seek to resolve physiological needs, then we can better understand what we should do with it. Understanding how we really respond to the world, we better design for those responses. In a post-truth society, empiricism and realism is our savior amongst a world of beliefs. The ethereal is combated by the corporeal. The phenomenology of spirit is just phenomena we don't understand. With today's tools, it's not that we don't understand, it's that we choose not to. We've seen how identity both protects us and endangers us through division. We've seen how objects can become weaponized and cultures exploited for profit. If identity and culture isn't the soul of our being, the definition of our existence, or the heart of our families, and

merely just a survival mechanism meant to help us be more familiar with our context, so we can predict other's behaviors and threats, then we must question why we protect it so aggressively. The answer on one end is safety. We want people to be healthy and safe through rooted understandings of our surroundings. The other hand comes down to the experiences of life. We need difference in life to help us discern and know our world. If everything was the same, we would be lost, and not just figuratively speaking. Just as we need contrast in our visual field and the melanopsin to modulate bodily reactions based on differing light qualities, we need different experiences to occupy our energies, feed our curiosities, and support our development. These are all developed from processes in the human body over time. That is experience, and it can be architectural experience if we design it as such.

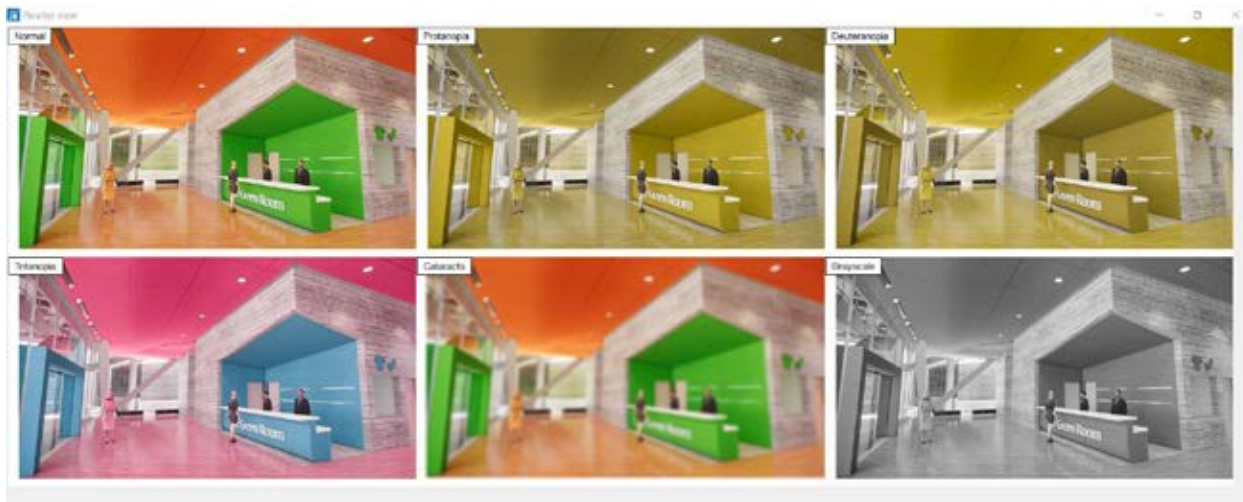

Figure 29: Tools such as Colour Contrast Analyser are used by web designers to accommodate accessibility requirements; architects can use these tools to better understand how people with different visual abilities see their spaces (diagrams by self; software from <https://developer.paciellogroup.com/resources/contrastanalyser/>)

closing remarks

At every turn we encounter physical objects fashioned by human design and endure natural forces whose imperatives structure our daily routines for survival. Our existence depends from one moment to the next on myriad micro-organisms and diverse higher species, on our own hazily understood bodily and cellular reactions and on pitiless cosmic motions, on the material artifacts and natural stuff that populate our environment, as well as on socioeconomic structures that produce and reproduce the conditions of our everyday lives.

In light of this massive materiality, how could we be anything other than materialist?

-Diana Coole and Samantha Frost, [Introducing New Materialism](#)¹

After going through the process of developing a research and theory-based thesis, I've come to appreciate further the benefits of learning can have on how we view the world. Over just the past 8 months I've grown much more tolerant of behaviors I've been hyper-critical of and gained emotional intelligence that has helped me in day to day debates with individuals I don't agree with. I must be honest and say the topic of study was partly political given the climate the world finds itself in. With extremist right-wing movements flourishing in shocking parts of the globe, I desired not to just find out how this is happening in large collective

groups, but how individuals can be okay with some of the things being said and done. In a matter of 10 years, I've seen individuals with clear minds and a kind disposition change into defensive people bent on blaming populations and people they don't know for the problems in their own lives. There are things that seemed straightforward and obvious to me that I couldn't find the way to explain to specific people I knew were capable of grasping the concepts (not needing them to agree, but just understand for sake of pushing the conversation forward).

I saw parallels with the political concerns and discussions I've had in my 11 years of combined educational and professional architecture experience with topics ranging from design aesthetics, policy, historical preservation and sustainability. I was constantly perplexed at how professionals, educators and students alike would pick sides of these debates and even argue against sustainable practice. It all functioned in a representationalism and post-truth manner that seemed built upon a fragile institution. But it wasn't enough for me to accept this as a reality and desired to know more. I took on design concepts that were based around empirical data and started to learn computing tools to provide performance feedback. Once I started doing this, I saw no other way of practicing architecture. I had tapped in to a whole new knowledge base that expanded the horizon of my capabilities. Not only did it expand my capabilities, unlike learning a new tool that extends your personal functionality, tapping into a database of sciences and theories that pushed boundaries meant I had the power of hundreds of thousands of individuals and over a century of empirical work to educate my decisions. Intuition isn't removed from the equation, but it certainly became much more informed.

I argued with myself a few times on whether I should propose a new theory for architecture in this thesis and decided this wasn't the format, nor had I gained enough experience in the topic

matter to say a theory would be thoroughly developed, but I have intent to advance these topics and carry through into the profession the benefits it can provide. Nevertheless, I came to accept a beginning framework for my professional career that summarizes much of what was discussed in this paper. It's simple, not ideological nor dogmatic, but a set of best practices that most would find it hard to argue in today's world. Its focused on the cliché of practicing in the here-and-now, designing contextually, but doesn't limit contextuality to just urban setting or formal relationships. Its built on the understanding that, even though your primary client is paying for the building and has their best interests at stake, the real client is humanity. They are the ones that must live with the building, and not just this generation, another generation will have to do something with the building. The buildings we put up are made of this earth by human hands, sculpted by natural forces over time and eventually returned to this earth. That means resources are finite, cyclical and in the scale of human development, immensely impactful on the health of the planet.

The framework to take the next steps forward is at heart post-human. It understands that we aren't in this world, *we are of it*. The world doesn't stop for a single individual and time is not built around a single person's experience. Just because our experience differs, doesn't mean it isn't shared with other bodies of molecules, whether or not they're what we define as living or conscious.

1. Diversify to Enrich - Dissolve boundaries of practice and engage in interdisciplinary practice as an ethical treatise
2. Difference and Discrimination - Understand the primary mechanisms of perception and how they utilize stress, alertness, relational analysis and schema to drive individual response

3. Social Plasticity - Understand the role of recall functions in establishing cultural predisposition within decision making processes and how they are altered or manipulated with exposure
4. Learn, Don't Repeat - Realize the detrimental capabilities of conservatism that establish borders and amplify bias without disregarding the behavioral necessity for culture and safety; learn the lessons of history, don't simply repeat them; everything has both successful and unsuccessful characteristics and learning involves discovering them both
5. Capitalize on Capabilities – Utilize data and analysis tools to support better design decisions and maximize the designer's ability to engage society; tapped into the wealth of accumulated knowledge available to us
6. Functional Aesthetics – By understanding how we perceive, experience and recall the built environment, we understand how aesthetics can be functional and designed to meet specific criteria

To address the two buzzwords that have negative connotations, by discrimination I don't mean to discriminate. What is meant by this is to understand why we discriminate and not just people, but objects. That means the functional purposes that include basic survival and interpretation of our surroundings that allows to assimilate. The other is conservatism; despite my political motivations inherent in some of the themes, when we speak of conservatism it is of practice, not ideology. Conservatism isn't the enemy, but it can pose a significant threat the humanity. We need conservatism for our comforts and stability. We are creatures that seek homeostasis, we need a balance of energy and forces to keep us living. Whenever this balance is thrown off, we begin to deteriorate. This is why stress and poor health (including exposure to VOCs) dissolves the telomeres of our DNA and causes degradation and death of cells (I couldn't encourage you enough to follow these topics, especially if you're a designer).² However, boredom and constant predictability produces stress as well. There is a balance, as there is anything in life.

This goes for identity as well. Some of this paper may seem like an attack on identity but it is a fundamental aspect of life. In our current evolutionary condition, we need identity to forge ourselves against the unknown. Insecurity is a fundamental social problem. Self-awareness and agency is important to our motivation for survival. Where we lack either, we often fill the void with faith. We desire control but will happily relinquish it for a little respite in hard times. This goes for identity and culture. You can't have both a society of fluid identity and multiple strong cultures. Fluid identity means homogenization, a word we don't often appreciate. But nothing in life is an either/or equation so we should come to understand there is a gradient between fluidity and culture that becomes the source of our ethical dilemma. We need to constantly question where on that line we fall and how we should proceed. We also need to understand that others will place themselves on that gradient elsewhere and we must find a way to live with it. Humanity evolves. We have been fascinated for centuries with the idea of revolution but that is an act of violence that only happens at moments of intense friction. To stick with science metaphors, resistance creates energy and a build up of energy creates instability. Materials have thresholds and even though some breakdown gradually, society does not. Society builds tension and has an explosive reaction. If we strive to understand it, we can build flexibility in it and help adapt it to the forces. Evolution is an adaptation to contextual forces; it isn't instant but takes time, time that we can't perceive well because our Cartesian humanist values. Instant gratification and intuition combine to form boundaries that don't allow us to address real pressing concerns. We must find a way to alter how we practice, communicate and think that will allow us and others to embrace post-humanist thought, engage in process and refocus on network causality if we want to better both the natural and built environments going forward. Design is a conversation, let's keep it moving in a forward direction.

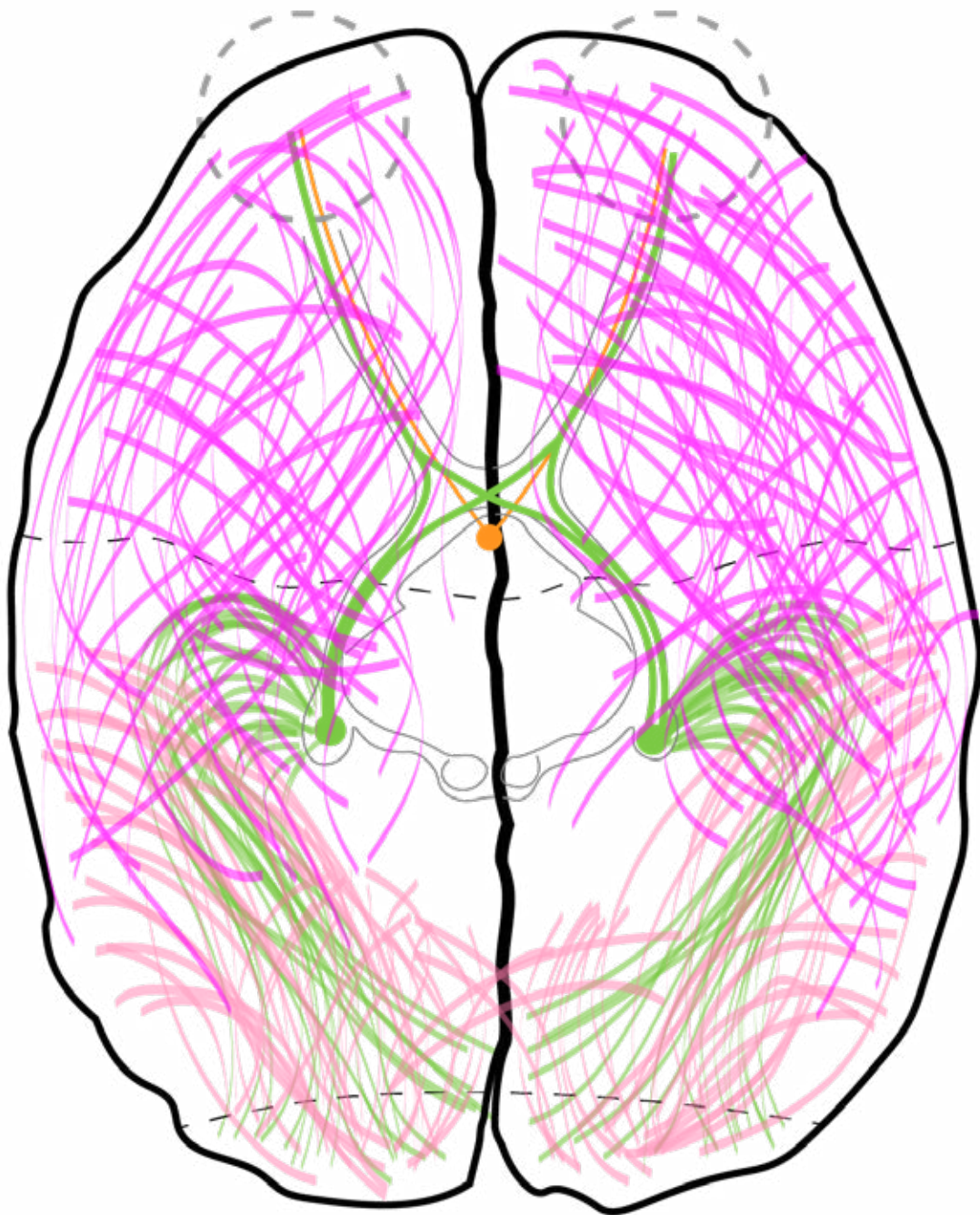

back matter

/ endnotes

preface and acknowledgements

¹ Salk, Jonas. 2008. "The Next Evolutionary Step in the Ascent of Man in the Cosmos." *Leonardo* 41 (3): 279-286. Accessed June 18, 2018. <https://www-mitpressjournals-org.offcampus.lib.washington.edu/doi/10.1162/leon.2008.41.3.279>.

introduction

¹ Mayne, Thom, Stan Allen, and Morphosis Architects. 2011. *Combinatory Urbanism: The Complex Behavior of Collective Form*. Edited by Stephanie Rigolot. Culver City, CA: Stray Dog Café, 28.

² 2011. "A Brief History of the Internet." *New Statesman* 140 (5066): 30. Accessed December 7, 2018. http://link.galegroup.com/apps/doc/A266346805/LitRC?u=wash_main&sid=LitRC&xid=d9810eda.

³ Nunnally, Brad, and David Farkas. 2017. *UX research: practical techniques for designing better products*. Beijing: O'Reilly Media. Accessed December 7, 2018. <https://www.safaribooksonline.com/library/view/ux-research/9781491951286/>.

⁴ Bachelard, Gaston. 1994. *The Poetics of Space*. Translated by Maria Jolas. Boston: Beacon Books, i.

⁵ Ibid.

- ⁶ Ibid. The inner light refers to a writing by René Huyghe where he discusses the work of painter Georges Rouault. Bachelard refers to this as the phenomenology of the soul.
- ⁷ Meshberger, Frank Lynn. 1990. "An Interpretation of Michelangelo's Creation of Adam Based on Neuroanatomy." *Journal of the American Medical Association* 1837-1841.
- ⁸ Marías, Julián. 1967. *History of Philosophy*. Translated by Stanley Appelbaum and Clarence Strowbridge. Mieola, NY: Dover Publications, Inc., 33-34.
- ⁹ Plato. 2004. *Republic*. Translated by Benjamin Jowett. New York: Barnes & Noble Classics.
- ¹⁰ Myers, David G. 2004. *Psychology*. 7th. New York: Worth Publishers, 2.
- ¹¹ *ibid.*, 4.
- ¹² Adorno, Theodore. 1997. "Functionalism Today." In *Rethinking Architecture: A Reader in Cultural Theory*, by Neil Leach, 5-19. New York: Routledge.
- ¹³ Benjamin, Walter. 1968. *The Work of Art in the Age of Mechanical Reproduction*. Edited by Hannah Arendt. Translated by Harry Zohn. New York: Schocken Books.
- ¹⁴ Leach, Neil. 1999. *The Anaesthetics of Architecture*. Cambridge, MA: The MIT Press.
- ¹⁵ Hollingworth, Andrew, and Steven J Luck, . 2008. *Visual Memory*. New York: Oxford University Press.
- ¹⁶ Etymonline. n.d. Etymonline.com. Accessed December 7, 2018.
<https://www.etymonline.com/word/imagine>.
- ¹⁷ Lacan, Jacques. 2004. "The Mirror Stage as Formative of the Function of the I." In *Literary Theory: An Anthology*, edited by Julie Rivkin and Michael Ryan. Maiden, MA: Blackwell Publishing. Accessed December 7, 2018.
https://s3.amazonaws.com/academia.edu.documents/37565438/Literary_Theory_-_An_Anthology_Blackwell_Anthologies_by_Julie_Rivkin_Michael_Ryan.pdf?AWSAccessKeyId=AKIAIWOWYYGZ2Y53UL3A&Expires=1544180037&Signature=a9cbDJxTUfPP9LYzTMjL1ShB4%2FE%3D&response-con, 442.
- ¹⁸ Etymonline. n.d. Etymonline.com. Accessed May 25, 2018.
<https://www.etymonline.com/word/identity>.
- ¹⁹ Freud, Sigmund. 2010. *Civilization and Its Discontents*. Translated by James Strachey. New York: W.W. Norton & Co.
- ²⁰ Myers, David G. 2004. *Psychology*. 7th. New York: Worth Publishers, 578-579.
- ²¹ Lacan, Jacques. 2004. "The Mirror Stage as Formative of the Function of the I." In *Literary Theory: An Anthology*, edited by Julie Rivkin and Michael Ryan. Maiden, MA: Blackwell Publishing. Accessed December 7, 2018.
https://s3.amazonaws.com/academia.edu.documents/37565438/Literary_Theory_-_An_Anthology_Blackwell_Anthologies_by_Julie_Rivkin_Michael_Ryan.pdf?AWSAccessKeyId=AKIAIWOWYYGZ2Y53UL3A&Expires=1544180037&Signature=a9cbDJxTUfPP9LYzTMjL1ShB4%2FE%3D&response-con, 442.
- ²² Horowitz, Mardi. 2014. *Identity and the New Psychoanalytic Explorations of Self-Organization*. New York: Routledge, 4.

- ²³ Barad, Karen. 2007. Meeting the Universe Halfway. Durham, NC: Duke University Press, 85.
- ²⁴ Perry, Marvin, Joseph R Peden, and Theodore H Von Laue. 2006. Sources of Western Tradition. New York: Houghton Mifflin Company.
- ²⁵ Tarnas, Richard. 1993. The Passion of the Western Mind. New York: Ballantine Books.
- ²⁶ Coole, Diana, and Samantha Frost. 2010. New Materialisms: Ontology, Agency, and Politics. Durham: Duke University Press.
- ²⁷ Barad, Karen. 2007. Meeting the Universe Halfway. Durham, NC: Duke University Press, 67.
- ²⁸ *ibid.*
- ²⁹ *ibid.* 44-59.
- ³⁰ Mayne, Thom, Stan Allen, and Morphosis Architects. 2011. Combinatory Urbanism: The Complex Behavior of Collective Form. Edited by Stephanie Rigolot. Culver City, CA: Stray Dog Café, 28.

image

- ¹ Benjamin, Walter. 1978. "A Berlin Chronicle." In Reflections: Essays, Aphorisms, Autobiographical Writing, by Peter Demetz. New York: Schocken Books, 28.
- ² Oxford Dictionaries. n.d. OxfordDictionaries.com. Accessed May 22, 2018. <https://en.oxforddictionaries.com/>.
- ³ Etymonline. n.d. Etymonline.com. Accessed April 24, 2018. <https://www.etymonline.com/>.
- Oxford Dictionaries. n.d. OxfordDictionaries.com. Accessed December 11, 2018. <https://en.oxforddictionaries.com/word/image>.
- ⁴ Etymonline. n.d. Etymonline.com. Accessed April 24, 2018. <https://www.etymonline.com/>.
Oxford Dictionaries. n.d. OxfordDictionaries.com. Accessed December 11, 2018. <https://en.oxforddictionaries.com/word/imagine>.
- ⁵ Benjamin, Walter. 1978. "A Berlin Chronicle." In Reflections: Essays, Aphorisms, Autobiographical Writing, by Peter Demetz. New York: Schocken Books, 28.
- ⁶ *ibid.*, 25.
- ⁷ *ibid.*, 26.
- ⁸ *ibid.*, 28.
- ⁹ *ibid.*, 40.
- ¹⁰ *ibid.*, 30-32.

¹¹ Nietzsche, Friedrich. 1957. *The Use and Abuse of History*. 2nd. Translated by Adrian Collins. New York: Macmillan Publishing Group, 14-15.

¹² Leach, Neil. 1999. *The Anaesthetics of Architecture*. Cambridge, MA: The MIT Press, 16.

¹³ Benjamin, Walter. 2010. "The Work of Art in the Age of Mechanical Reproduction," trans. Michael Jennings. *Grey Room* 39: 11-37. Accessed November 26, 2017. <http://www.jstor.org/stable/27809424>.

¹⁴ Leach, Neil. 1999. *The Anaesthetics of Architecture*. Cambridge, MA: The MIT Press, 55.

¹⁵ Leach, Neil. 1999. *The Anaesthetics of Architecture*. Cambridge, MA: The MIT Press, 56-58.

¹⁶ McDonough, Thomas F. 1994. "Situationsist Space." *October* (The MIT Press) 67: 58-77. Accessed February 13, 2018. <http://www.jstor.org/stable/778967>, 60.

¹⁷ *ibid.*, 64

¹⁸ Venturi, Robert. 1996. *Iconography and Electronics upon a Generic Architecture: a view from the drafting room*. Cambridge, MA: The MIT Press.

¹⁹ Venturi, Robert. 2008. "Viva Mannerism for Architecture for our Age." *Log* (13/14): 152-153.

²⁰ Leach, Neil. 1999. *The Anaesthetics of Architecture*. Cambridge, MA: The MIT Press, 62-65.

²¹ Phillips, Patricia C., James Wines, and Site, Inc. 1982. *Highrise of Homes*. New York: Rizzoli.

²² Koolhaas, Rem. 1994. *Delirious New York*. New York: The Monacelli Press.

²³ Koolhaas, Rem. 1995. "Generic City." In *S,M,L,XL*, by Office of Metropolitan Architecture, Rem Koolhaas and Bruce Mau, edited by Jennifer Sigler. New York: The Monacelli Press, Inc.. 1248.

²⁴ *ibid.*

²⁵ *ibid.* 1248-1257.

²⁶ Leach, Neil. 2006. *Camouflage*. Cambridge: MIT Press.

²⁷ *ibid.*, 21-29.

²⁸ *ibid.*, 144-147.

²⁹ *ibid.*, 242-247.

³⁰ Diagram by self, derived from Bill Brown's *Other Things*.

³¹ Plato. 2004. Republic. Translated by Benjamin Jowett. New York: Barnes & Noble Classics, 224-256.

³² Heidegger, Martin. 2008. "The Thing." In *The Object Reader*, edited by Fiona Candlin and Raiford Guins, 113. New York: Routledge, 113-123.

³³ Harman, Graham. 2018. Object Oriented Ontology: A New Theory of Everything. London: Penguin Random House UK, 149-161.

³⁴ Brown, Bill. 2015. Other Things. Chicago: University of Chicago Press, 20-23.

³⁵ Barad, Karen. 2007. Meeting the Universe Halfway. Durham, NC: Duke University Press, 48.

³⁶ *ibid.*, 49.

perception and process

¹ Goldhagen, Sarah Williams. 2017. Welcome to Your World: How the Built Environment Shapes Our Lives. New York: HarperCollins.

² Sapolsky, Robert M. 2017. Behave. New York: Penguin Press, 681-696.

³ *ibid.*, 707-710.

⁴ Danckert, James, and Colleen Merrifield. 2018. "Boredom, sustained attention and the default mode network." *Experimental Brain Research* (236): 2507-2518. <https://doi.org/10.1007/s00221-016-4617-5>.

⁵ *ibid.*

⁶ Sapolsky, Robert M. 2017. Behave. New York: Penguin Press, 65-70..

⁷ Khademagha, P., M.B.C. Aries, A.L.P. Rosemann, and E.J. van Loenen. 2016. "Implenenting non-image-forming effects of light in the built environment: A review on what we need." *Building and Environment* (Elsevier Ltd.) 108: 264. Accessed June 13, 2018. doi:<https://doi.org/10.1016/j.buildenv.2016.08.035>.

⁸ Purves, Dale, George J. Augustine, David Fitzpatrick, William C. Hall, Anthony-Samuel LaMantia, James O. McNamara, and S. Mark Williams, . 2004. Neuroscience. Third. Sunderland, MA: Sinauer Associates, Inc.: 234-236.

⁹ *Ibid.*: 236-240.

¹⁰ Khademagha, P., M.B.C. Aries, A.L.P. Rosemann, and E.J. van Loenen. 2016. "Implenenting non-image-forming effects of light in the built environment: A review on what we need." *Building*

and Environment (Elsevier Ltd.) 108: 265. Accessed June 13, 2018.
doi:<https://doi.org/10.1016/j.buildenv.2016.08.035>.

¹¹ Cutolo, Maurizio, Alberto Sulli, Carmen Pizzorni, Maria Elena Secchi, Stefano Soldano, Bruno Serio, Rainer H. Straub, Kati Otsa, and Georges J. Maestroni. 2006. "Circadian Rhythms." *Annals of New York Academy of Sciences* 1069 (1): 289-299.

¹² Ewing, Phillip H., John Haymaker, and Eve A. Edelstein. 2017. "Simulating Circadian Light: Multi-Dimensional Illuminance Analysis." *Proceedings of the 15th IBPSA Conference*. San Francisco: International Building Performance Simulation Association. 2363-2371. Accessed June 13, 2018. doi:10.26868/25222708.2017.660.

¹³ Usrey, W. Martin, and Henry J. Alitto. 2015. "Visual Functions of the Thalamus." *Annual Review of Vision Science* 351-371. Accessed October 11, 2018. doi:10.1146/annurev-vision-082114-035920.

¹⁴ Purves, Dale, George J. Augustine, David Fitzpatrick, William C. Hall, Anthony-Samuel LaMantia, James O. McNamara, and S. Mark Williams, . 2004. *Neuroscience*. Third. Sunderland, MA: Sinauer Associates, Inc.: 260-281.

¹⁵ Usunoff, Kamen G., Oliver Schmitt, Nikolai E. Lazarov, E. Dimitar Itzev, Arndt Rolfs, and Andreas Wree. 2008. "Amygdala and Subcortical Vision: Recognition of Threat and Fear." *Biomedical Review* 19: 1-16. Accessed November 16, 2018.

¹⁶ Sapolsky, Robert M. 2017. *Behave*. New York: Penguin Press, 22-25.

¹⁷ *ibid.*, 26-31.

¹⁸ Purves, Dale, George J. Augustine, David Fitzpatrick, William C. Hall, Anthony-Samuel LaMantia, James O. McNamara, and S. Mark Williams, . 2004. *Neuroscience*. Third. Sunderland, MA: Sinauer Associates, Inc, 697-700.

¹⁹ Sapolsky, Robert M. 2017. *Behave*. New York: Penguin Press, 34-39.

²⁰ Mlodinow, Leonard. 2012. *Subliminal: How Your Unconscious Mind Rules Your Behavior*. New York: Vintage Books, 154.

²¹ Cardiff, Janet, and George Bures Miller. n.d. "Janet Cardiff & George Bures Miller | Dark Pool | 1995." *Cardiffmiller.com*. Accessed December 13, 2018.
<https://www.cardiffmiller.com/artworks/inst/darkpool.html>.

²² Sapolsky, Robert M. 2017. *Behave*. New York: Penguin Press, 42.

²³ Kensinger, Elizabeth A. 2009. *Emotional Memory Across the Adult Lifespan*. New York: Psychology Press, 15.

²⁴ Ishai, Alomit. 2009. "Retrieving Pictures from Long-term Memory." In *Neuroimaging of Human Memory: Linking Cognitive Processes to Neural Systems*, edited by Frank Rösler, Charan Ranganath, Brigitte Röder and Rainer H. Kluwe, 265-281. New York: Oxford University Press.

- ²⁵ Herman, James P, Michelle M Ostrander, Nancy K Mueller, and Helmer Figueiredo. 2005. "Limbic System Mechanisms of Stress Regulation: Hypothalamo-pituitary-adrenocortical axis." *Progress in Neuro-Psychopharmacology & Biological Psychiatry* (Elsevier Inc.) (29): 1201-1213.
- ²⁶ Sapolsky, Robert M. 2017. *Behave*. New York: Penguin Press, 148-149.
- ²⁷ Lew, Adina R. 2011. "Looking Beyond the Boundaries: Time to Put Landmarks Back on the Cognitive Map?" *Psychological Bulletin* 137 (3): 484-507. Accessed January 20, 2017. doi:10.1037/a0022315.
- ²⁸ Sapolsky, Robert M. 2017. *Behave*. New York: Penguin Press, 151.
- ²⁹ Purves, Dale, George J. Augustine, David Fitzpatrick, William C. Hall, Anthony-Samuel LaMantia, James O. McNamara, and S. Mark Williams, 2004. *Neuroscience*. Third. Sunderland, MA: Sinauer Associates, Inc.: 484-486.
- ³⁰ Ishizu, Tomohiro, and Semir Zeki. 2011. "Toward a Brain-Based Theory of Beauty." Edited by Eric James Warrant. *PLoS One* 6 (7): e21852. Accessed December 12, 2018. doi:10.1371/journal.pone.0021852.
- ³¹ O'Doherty, John P. 2009. "Reinforcement Learning Mechanisms in the Human Brain: Insights from model-based fMRI." In *Neuroimaging of Human Memory: Linking Cognitive Processes to Neural Systems*, edited by Frank Röser, Charan Ranganath, Brigitte Röder and Rainer H. Kluwe, 46-63. New York: Oxford University Press, 47.
- ³² Stevens, Francis L., Robin A. Hurley, and Katherine H. Taber. 2011. "Anterior Cingulate Cortex: Unique Role in Cognition and Emotion." *Windows to the Brain* 23 (2): 120-125. Accessed December 12, 2018. <https://neuro.psychiatryonline.org/doi/pdf/10.1176/jnp.23.2.jnp121>, 121-122. Cingulate Cortex: Unique Role in Cognition and Emotion." *Windows to the Brain* 23 (2): 120-125. Accessed December 12, 2018. <https://neuro.psychiatryonline.org/doi/pdf/10.1176/jnp.23.2.jnp121>, 121-122.
- ³³ *ibid*.
- ³⁴ Stevens, Francis L., Robin A. Hurley, and Katherine H. Taber. 2011. "Anterior Cingulate Cortex: Unique Role in Cognition and Emotion." *Windows to the Brain* 23 (2): 120-125. Accessed December 12, 2018. <https://neuro.psychiatryonline.org/doi/pdf/10.1176/jnp.23.2.jnp121>, 121-122.
- ³⁵ Danckert, James, and Colleen Merrifield. 2018. "Boredom, sustained attention and the default mode network." *Experimental Brain Research* (236): 2507-2518. <https://doi.org/10.1007/s00221-016-4617-5>, 2516.
- ³⁶ Fischer, David B., Aaron D. Boes, Athena Demertzi, Henry C. Evrard, Steven Laureys, Brian L. Edlow, Liu Hesheng, et al. 2016. "A Human Brain Network Derived from Coma-causing Brainstem Lesions." *Neurology* (87): 1-8. Accessed December 12, 2018. doi:10.1212/WNL.0000000000003404.

³⁷ Starr, G. Gabrielle. 2013. *Feeling Beauty the neuroscience of aesthetic experience*. Cambridge, MA: The MIT Press.

³⁸ Ishizu, Tomohiro, and Semir Zeki. 2011. "Toward a Brain-Based Theory of Beauty." Edited by Eric James Warrant. *PLoS One* 6 (7): e21852. Accessed December 12, 2018. doi:10.1371/journal.pone.0021852.

³⁹ Sapolsky, Robert M. 2017. *Behave*. New York: Penguin Press, 64-65.

⁴⁰ 2015. "Wikimedia Commons." File: Dopaminergic pathways.svg. October 22. Accessed December 12, 2018. https://commons.wikimedia.org/wiki/File:Dopaminergic_pathways.svg.

⁴¹ *ibid.*, 75.

⁴² Sapolsky, Robert M. 2017. *Behave*. New York: Penguin Press, 70-75.

⁴³ Dudai, Yadin. 2007. "Memory: it's all about representations." In *Science of Memory: Concepts*, 13-16. New York: Oxford University Press, 15.

⁴⁴ Holmes, Emily A., and Andrew Mathews. 2010. "Mental Imagery in Emotion and Emotional Disorders." *Clinical Psychology Review (Elsevier)* 349-362. Accessed December 12, 2018. doi:10.1016/j.cpr.2010.01.001.

⁴⁵ Hasselmo, Michael E. 2007. "Encoding: Models linking neural mechanisms to behavior." In *Science of Memory: Concepts*, 123-128. New York: Oxford University Press, 125.

⁴⁶ Moscovitch, Morris. 2007. "Memory: Why the engram is elusive." In *Science of Memory: Concepts*, 16-22. New York: Oxford University Press, 15-19.

⁴⁷ Tulving, Endel. 2007. "Coding and Representation: SEarching for a home in the brain." In *Science of Memory: Concepts*, 65-68. New York: Oxford University Press.

⁴⁸ Hollingworth, Andrew, and Steven J. Luck. 2008. "Visual Memory Systems." In *Visual Memory*, 3-7. New York: Oxford University Press.

⁴⁹ Hollingworth, Andrew. 2008. "Visual Memory for Natural Scenes." In *Visual Memory*, 123-162. New York: Oxford University Press.

⁵⁰ Smith, Steven M. 2007. "Context: a reference for focal experience." In *Science of Memory: Concepts*, 111-114. New York: Oxford University Press.

⁵¹ Mlodinow, Leonard. 2012. *Subliminal: How Your Unconscious Mind Rules Your Behavior*. New York: Vintage Books, 21-25.

⁵² *ibid.*, 75.

⁵³ *ibid.*, 83.

⁵⁴ Appiah, Kwame Anthony. 2018. *The Lies That Bind*. New York: Liveright Publishing Corporation, 1-9.

⁵⁵ *ibid.*, 9.

⁵⁶ *ibid.*, 9-11.

⁵⁷ *ibid.*, 11.

⁵⁸ Leach, Neil. 2006. *Camouflage*. Cambridge: MIT Press, 145.

⁵⁹ *ibid.*, 145-147.

⁶⁰ Mlodinow, Leonard. 2012. *Subliminal: How Your Unconscious Mind Rules Your Behavior*. New York: Vintage Books, 170.

⁶¹ Sapolsky, Robert M. 2017. *Behave*. New York: Penguin Press, 387-407.

⁶² *ibid.*, 555.

⁶³ Lang, Jon. 1992. "Symbolic Aesthetics in Architecture." In *Environmental Aesthetics*, 11-26. New York: Press Syndicate of the University of Cambridge, 21.

⁶⁴ Mlodinow, Leonard. 2012. *Subliminal: How Your Unconscious Mind Rules Your Behavior*. New York: Vintage Books, 34.

⁶⁵ Oakley, David A., and Peter W. Halligan. 2017. "Chasing the Rainbow: The Non-conscious Nature of Being." *Frontiers in Psychology* 8: 1924. Accessed December 4, 2018. doi:10.3389/fpsyg.2017.01924.

what can you do?

¹ Mackenzie, Andrew. 2014. "Rem Koolhaas: National Identity in Architecture." *Architecture Australia (Architecture Australia)* 103 (2). Accessed December 9, 2018. <https://architectureau.com/articles/national-identity-in-architecture-an-interview-with-rem-koolhaas/>.

² Academy of Neuroscience for Architecture. n.d. [anfa.org](http://www.anfa.org). Accessed December 9, 2018. <https://www.anfa.org>.

³ NewSchool of Architecture and Design. n.d. *Certificates and Minors*. Accessed December 9, 2018. <https://newschoolarch.edu/academics/certificates-and-minors/professional-development/>.

⁴ Mullinex, Ryan. 2018. "Neuroscience is Optimizing the Office." *nbbX (NBBJ)*. Accessed December 9, 2018. <http://meanstheworld.co/work/neuroscience-is-optimizing-the-office>.

- ⁵ Medina, Dr. John. 2016. "Understanding How Our Brains Work Makes for Better Buildings." nbbX (NBBJ). Accessed December 9, 2018. <http://meanstheworld.co/well-being/understanding-how-our-brains-work-makes-for-better-buildings>.
- ⁶ Perkins+Will. n.d. Human Experience. Accessed December 9, 2018. <http://research.perkinswill.com/labs/experience/#>.
- ⁷ Perkins+Will. n.d. Eve Edelstien. Accessed December 2018, 2018. <https://perkinswill.com/people/eve-edelstein>.
- ⁸ Blumenfeld, Joan, Carolyn BaRoss, and Sonya Dufner. 2009. "Transcending Project Type - Principles for High Performance Interior Design." Edited by Ajla Aksamija, Ph.D. and Kalpana Kuttaiah. Perkins+Will Research Journal (Perkins+Will) 01 (02): 83-106.
- ⁹ Perkins+Will. n.d. *Material Performance*. Accessed December 9, 2018. <http://research.perkinswill.com/labs/materials/>.
- ¹⁰ Perkins+Will. n.d. Transparency. Accessed December 9, 2018. <https://transparency.perkinswill.com>.
- ¹¹ NAC. n.d. NACLab. Accessed December 9, 2018. <https://nacarchitecture.com/NACLab/default.aspx>.
- ¹² Scranton, Lauren. 2018. "Architecture + Human Behavior: Strategies for Enhanced Wellbeing in Residence Halls." NACLab (NAC). Accessed December 9, 2018. <https://nacarchitecture.com/NACLab/architecture-plus-human-behavior.aspx>.
- ¹³ Kurtz, Jill. 2018. "Designing Environments for Memory Care Residents." NACLab (NAC). Accessed December 9, 2018. <https://nacarchitecture.com/NACLab/designing-for-memory-care.html>.
- ¹⁴ Corgan. n.d. "Spatial Problem Solving: Corgan Studies Intuitive Wayfinding." Corgan Blog (Corgan). Accessed December 9, 2018. <https://www.corgan.com/story/spatial-problem-solving-corgan-studies-intuitive-wayfinding/>.
- ¹⁵ Woods Bagot. n.d. Superspace | Enterprise | Woods Bagot. Accessed December 9, 2018. <https://www.woodsbagot.com/enterprise/superspace>.
- ¹⁶ Velux. n.d. Daylight Requirements in Building Codes. Accessed December 9, 2018. <https://www.velux.com/deic/daylight/daylight-requirements-in-building-codes>.
- ¹⁷ Building Research Establishment Environmental Assessment Method. n.d. Hea 01 Visual Comfort. Accessed December 9, 2018. https://www.breeam.com/BREEAMUK2014SchemeDocument/content/05_health/hea01_nc.htm#average_daylight_factor.

¹⁸ Brennan, Martin Timothy, and Alex Robert Collins. 2018. "Outcome-Based Design for Circadian Lighting: An Integrated Approach to Simulation & Metrics." 2018 Building Performance Analysis Conference and SimBuild (ASHRAE and IBPSA-USA) 141-148.

¹⁹ U.S. Green Building Council. n.d. Interior Lighting - Quality. Accessed December 9, 2018. <https://www.usgbc.org/credits/new-construction-core-and-shell-schools-new-construction-retail-new-construction-healthca-36>.

²⁰ Nordh, Helena, Caroline Hagerhall, and Kenneth Holmqvist. 2013. "Tracking Restorative Components: Patterns in Eye Movements as a Consequence of Restorative Rating Task." *Landscape Research* 38 (1): 101-116. Accessed October 1, 2018. doi:10.1080/01426397.2012.691468.

²¹ Perkins+Will. n.d. *ideas+buildings*. Accessed December 9, 2018. <http://blog.perkinswill.com/>.

²² NBBJ. n.d. nbbX. Accessed December 9, 2018. <http://meanstheworld.co/>.

²³ Woods Bagot. n.d. ideas. Accessed December 9, 2018. <https://www.woodsbagot.com/ideas>.

²⁴ Kieran Timberlake. n.d. Updates. Accessed December 9, 2018. <https://kierantimberlake.com/posts/>.

²⁵ NAC. n.d. NACLab. Accessed December 9, 2018. <https://nacarchitecture.com/NACLab/default.aspx>.

²⁶ ZGF. n.d. Process. Accessed December 9, 2018. <https://www.zgf.com/process/>.

²⁷ UNSense. n.d. UNSense. Accessed December 9, 2018. <http://unsense.com/>.

²⁸ Hershberger, Robert G. 1992. "Meaning and Architecture". Vol. 1st paperback, in *Environmental Aesthetics*, edited by Jack L. Nasar, 175-194. New York: Cambridge University Press.

²⁹ Hershberger, Robert G., and Robert C. Cass. 1992. "Predicting User Responses to Buildings." In *Environmental Aesthetics*, edited by Jack L. Nasar, 195-211. New York: Cambridge University Press.

³⁰ Groat, Linda N. 1983. "Contextual Compatibility in Architecture: an issue of personal taste?" In *Environmental Aesthetics*, edited by Jack L. Nasar, 228-253. New York: Cambridge University Press.

³¹ Amedeo, Douglas, Reginald G. Golledge, and Robert J. Stimson. 2009. *Person-Environment-Behavior Research*. New York: The Guilford Press, 233.

³² *ibid.*, 233-244.

³³ *ibid.*, 244-251.

³⁴ Vartanian, Oshin, Anjan Chatterjee, Helmut Leder, Nicolai Rostrup, Gorka Navarrete, Lars Brorson Fich, Cristián Modroño, Martin Skov, Marcos Nadal, and Guido Corradi. 2017. "Preference for Curvilinear Contour in Interior Architectural Spaces: Evidence from Experts and Nonexperts." *Psychology of Aesthetics, Creativity, and the Arts*. Accessed October 1, 2018. <http://dx.doi.org/10.1037/aca0000150>.

³⁵ Dovey, Kim. 2017. "One-way Street." In *Take One Building: interdisciplinary research perspectives of the Seattle Central Library*, 53-66. New York: Routledge, Taylor & Francis Group, 55-65.

³⁶ University College London. n.d. *Space Syntax*. Accessed December 10, 2018. <http://otp.spacesyntax.net/>.

³⁷ Dovey, Kim. 2017. "One-way Street." In *Take One Building: interdisciplinary research perspectives of the Seattle Central Library*, 53-66. New York: Routledge, Taylor & Francis Group,

³⁸ *ibid.*, 64.

³⁹ Dalton, Ruth Conroy. 2017. "OMA's Conception of the Users of Seattle Central Library." In *Take One Building*, 38-50. New York: Routledge, Taylor & Francis Group.

⁴⁰ Frampton, Kenneth. 1992. *Modern Architecture: A Critical History*. 3rd. New York: Thames and Hudson Ltd., 314.

⁴¹ *ibid.*

⁴² Leach, Neil. 2006. *Camouflage*. Cambridge: MIT Press, 147.

⁴³ *ibid.*, 145-147.

⁴⁴ Speaks, Michael. 2010. "Design Intelligence Part 1: Introduction." In *Constructing a New Agenda: Architectural Theory 1993-2009*, edited by A. Krista Sykes, 206-207. New York: Princeton Architectural Press, 208-209.

⁴⁵ *ibid.*, 209.

⁴⁶ *ibid.*, 210-211.

⁴⁷ *ibid.*, 211-2013.

⁴⁸ *ibid.*, 213.

⁴⁹ Graafland, Arie. 2010. "On Criticality." In *Constructing a New Agenda: Architectural Theory 1993-2009*, edited by A. Krista Sykes, 396-417. New York: Princeton Architectural Press, 400-404.

⁵⁰ *ibid.*, 401.

⁵¹ *ibid.*, 401-404.

⁵² *ibid.*, 396-405.

⁵³ *ibid.*, 407-408.

⁵⁴ *ibid.*, 408.

⁵⁵ *ibid.*, 409.

⁵⁶ Woods, Lebbeus. 2009. "Same Difference." Lebbeus Woods Blog. Accessed November 30, 2018. <https://lebbeuswoods.wordpress.com/2009/01/13/same-difference/>.

⁵⁷ *ibid.*

closing remarks

¹ Coole, Diana, and Samantha Frost. 2010. *New Materialisms: Ontology, Agency, and Politics*. Durham: Duke University Press.

² Shamma, Masood A. 2011. "Telomeres, lifestyle, cancer, and aging." National Health Institute - Public Access 28-34. doi:10.1097/MCO.0b013e32834121b1.

/bibliography

2011. "A Brief History of the Internet." *New Statesman* 140 (5066): 30. Accessed December 7, 2018.
http://link.galegroup.com/apps/doc/A266346805/LitRC?u=wash_main&sid=LitRC&xid=d9810eda.
- Academy for Neuroscience for Architecture. n.d. *History*. Accessed May 28, 2018.
<http://anfarch.org/about-2/history/>.
- Academy of Neuroscience for Architecture. n.d. *anfa.org*. Accessed December 9, 2018.
<https://www.anfa.org>.
- Adorno, Theodore. 1997. "Functionalism Today." In *Rethinking Architecture: A Reader in Cultural Theory*, by Neil Leach, 5-19. New York: Routledge.
- Amedeo, Douglas, Reginald G. Golledge, and Robert J. Stimson. 2009. *Person-Environment-Behavior Research*. New York: The Guilford Press.
- Appiah, Kwame Anthony. 2018. *The Lies That Bind*. New York: Liveright Publishing Corporation.
- Bachelard, Gaston. 1994. *The Poetics of Space*. Translated by Maria Jolas. Boston: Beacon Books.
- Barad, Karen. 2007. *Meeting the Universe Halfway*. Durham, NC: Duke University Press.
- Benjamin, Walter. 1978. "A Berlin Chronicle." In *Reflections: Essays, Aphorisms, Autobiographical Writing*, by Peter Demetz. New York: Schocken Books.
- . 2010. "The Work of Art in the Age of Mechanical Reproduction." *Grey Room* 39: 11-37. Accessed November 26, 2017. <http://www.jstor.org/stable/27809424>.
- . 1968. *The Work of Art in the Age of Mechanical Reproduction*. Edited by Hannah Arendt. Translated by Harry Zohn. New York: Schocken Books.
- Blumenfeld, Joan, Carolyn BaRoss, and Sonya Dufner. 2009. "Transcending Project Type - Principles for High Performance Interior Design." Edited by Ajla Aksamija, Ph.D. and Kalpana Kuttaiah. *Perkins+Will Research Journal* (Perkins+Will) 01 (02): 83-106.

- Brennan, Martin Timothy, and Alex Robert Collins. 2018. "Outcome-Based Design for Circadian Lighting: An Integrated Approach to Simulation & Metrics." *2018 Building Performance Analysis Conference and SimBuild* (ASHRAE and IBPSA-USA) 141-148.
- Brown, Bill. 2015. *Other Things*. Chicago: University of Chicago Press.
- Brownlee, David B, and David G De Long. 1997. *Kahn*. New York: Universe Publishing.
- Building Research Establishment Environmental Assessment Method. n.d. *Hea 01 Visual Comfort*. Accessed December 9, 2018. https://www.breeam.com/BREEAMUK2014SchemeDocument/content/05_health/hea01_nc.htm#average_daylight_factor.
- Cardiff, Janet, and George Bures Miller. n.d. "Janet Cardiff & George Bures Miller | Dark Pool | 1995." *Cardiffmiller.com*. Accessed December 13, 2018. <https://www.cardiffmiller.com/artworks/inst/darkpool.html>.
- Cha, Jiok, Tsafir Greenberg, Joshua M Carlson, Daniel J DeDora, Greg Hajcak, and Lilianne R Mujica-Parodi. 2014. "Circuit-Wide Structural and Functional Measures Predict Ventromedial Prefrontal Cortex Fear Generalization: Implications for Generalized Anxiety Disorder." *The Journal of Neuroscience* 34 (11): 4043-4053.
- Coole, Diana, and Samantha Frost. 2010. *New Materialisms: Ontology, Agency, and Politics*. Durham: Duke University Press.
- Corgan. n.d. "Spatial Problem Solving: Corgan Studies Intuitive Wayfinding." *Corgan Blog* (Corgan). Accessed December 9, 2018. <https://www.corgan.com/story/spatial-problem-solving-corgan-studies-intuitive-wayfinding/>.
- Cutolo, Maurizio, Alberto Sulli, Carmen Pizzorni, Maria Elena Secchi, Stefano Soldano, Bruno Serio, Rainer H. Straub, Kati Otsa, and Georges J. Maestroni. 2006. "Circadian Rhythms." *Annals of New York Academy of Sciences* 1069 (1): 289-299.
- Dalton, Ruth Conroy. 2017. "OMA's Conception of the Users of Seattle Central Library." In *Take One Building*, 38-50. New York: Routledge, Taylor & Francis Group.
- Danckert, James, and Colleen Merrifield. 2018. "Boredom, sustained attention and the default mode network." *Experimental Brain Research* (236): 2507-2518. <https://doi.org/10.1007/s00221-016-4617-5>.

- Dovey, Kim. 2017. "One-way Street." In *Take One Building: interdisciplinary research perspectives of the Seattle Central Library*, 53-66. New York: Routledge, Taylor & Francis Group.
- Dudai, Yadin. 2007. "Memory: it's all about representations." In *Science of Memory: Concepts*, 13-16. New York: Oxford University Press.
- Etymonline. n.d. *Etymonline.com*. Accessed April 24, 2018. <https://www.etymonline.com/>.
- Ewing, Phillip H., John Haymaker, and Eve A. Edelstein. 2017. "Simulating Circadian Light: Multi-Dimensional Illuminance Analysis." *Proceedings of the 15th IBPSA Conference*. San Francisco: International Building Performance Simulation Association. 2363-2371. Accessed June 13, 2018. doi:10.26868/25222708.2017.660 .
- Fischer, David B., Aaron D. Boes, Athena Demertzi, Henry C. Evrard, Steven Laureys, Brian L. Edlow, Liu Hesheng, et al. 2016. "A Human Brain Network Derived from Coma-causing Brainstem Lesions." *Neurology* (87): 1-8. Accessed December 12, 2018. doi:10.1212/WNL.0000000000003404.
- Frampton, Kenneth. 1992. *Modern Architecture: A Critical History*. 3rd. New York: Thames and Hudson Ltd.
- Freud, Sigmund. 2010. *Civilization and Its Discontents*. Translated by James Strachey. New York: W.W. Norton & Co.
- Goldhagen, Sarah Williams. 2017. *Welcome to Your World: How the Built Environment Shapes Our Lives*. New York: HarperCollins.
- Graafland, Arie. 2010. "On Criticality." In *Constructing a New Agenda: Architectural Theory 1993-2009*, edited by A. Krista Sykes, 396-417. New York: Princeton Architectural Press.
- Groat, Linda N. 1983. "Contextual Compatibility in Architecture: an issue of personal taste?" In *Environmental Aesthetics*, edited by Jack L. Nasar, 228-253. New York: Cambridge University Press.
- Harman, Graham. 2018. *Object Oriented Ontology: A New Theory of Everything*. London: Penguin Random House UK.
- Hasselmo, Michael E. 2007. "Encoding: Models linking neural mechanisms to behavior." In *Science of Memory: Concepts*, 123-128. New York: Oxford University Press.

- Heidegger, Martin. 2008. "The Thing." In *The Object Reader*, edited by Fiona Candlin and Raiford Guins, 113. New York: Routledge.
- Herman, James P, Michelle M Ostrander, Nancy K Mueller, and Helmer Figueiredo. 2005. "Limbic System Mechanisms of Stress Regulation: Hypothalamo-pituitary-adrenocortical axis." *Progress in Neuro-Psychopharmacology & Biological Psychiatry* (Elsevier Inc.) (29): 1201-1213.
- Hershberger, Robert G. 1992. *Meaning and Architecture*. Vol. 1st paperback, in *Environmental Aesthetics*, edited by Jack L. Nasar, 175-194. New York: Cambridge University Press.
- Hershberger, Robert G., and Robert C. Cass. 1992. "Predicting User Responses to Buildings." In *Environmental Aesthetics*, edited by Jack L. Nasar, 195-211. New York: Cambridge University Press.
- Hollingworth, Andrew. 2008. "Visual Memory for Natural Scenes." In *Visual Memory*, 123-162. New York: Oxford University Press.
- Hollingworth, Andrew, and Steven J Luck, . 2008. *Visual Memory*. New York: Oxford University Press.
- Hollingworth, Andrew, and Steven J. Luck. 2008. "Visual Memory Systems." In *Visual Memory*, 3-7. New York: Oxford University Press.
- Holmes, Emily A., and Andrew Mathews. 2010. "Mental Imagery in Emotion and Emotional Disorders." *Clinical Psychology Review* (Elsevier) 349-362. Accessed December 12, 2018. doi:10.1016/j.cpr.2010.01.001.
- Horowitz, Mardi. 2014. *Identity and the New Psychoanalytic Explorations of Self-Organization*. New York: Routledge.
- Ishai, Alomit. 2009. "Retrieving Pictures from Long-term Memory." In *Neuroimaging of Human Memory: Linking Cognitive Processes to Neural Systems*, edited by Frank Rösler, Charan Ranganath, Brigitte Röder and Rainer H. Kluwe, 265-281. New York: Oxford University Press.
- Ishizu, Tomohiro, and Semir Zeki. 2011. "Toward a Brain-Based Theory of Beauty." Edited by Eric James Warrant. *PLoS One* 6 (7): e21852. Accessed December 12, 2018. doi:10.1371/journal.pone.0021852.

- Kensinger, Elizabeth A. 2009. *Emotional Memory Across the Adult Lifespan*. New York: Psychology Press.
- Khademagha, P., M.B.C. Aries, A.L.P. Rosemann, and E.J. van Loenen. 2016. "Implementing non-image-forming effects of light in the built environment: A review on what we need." *Building and Environment* (Elsevier Ltd.) 108: 263-272. Accessed June 13, 2018. doi:<https://doi.org/10.1016/j.buildenv.2016.08.035>.
- Kieran Timberlake. n.d. *Updates*. Accessed December 9, 2018. <https://kierantimberlake.com/posts/>.
- Koolhaas, Rem. 1994. *Delirious New York*. New York: The Monacelli Press.
- . 1995. "Generic City." In *S,M,L,XL*, by Office of Metropolitan Architecture, Rem Koolhaas and Bruce Mau, edited by Jennifer Sigler. New York: The Monacelli Press, Inc.
- Kurtz, Jill. 2018. "Designing Environments for Memory Care Residents." *NACLab* (NAC). Accessed December 9, 2018. <https://nacarchitecture.com/NACLab/designing-for-memory-care.html>.
- Lacan, Jacques. 2004. "The Mirror Stage as Formative of the Function of the I." In *Literary Theory: An Anthology*, edited by Julie Rivkin and Michael Ryan. Maiden, MA: Blackwell Publishing. Accessed December 7, 2018. https://s3.amazonaws.com/academia.edu.documents/37565438/Literary_Theory_-_An_Anthology_Blackwell_Anthologies_by_Julie_Rivkin___Michael_Ryan.pdf?AWSAccessKeyId=AKIAIWOWYYGZ2Y53UL3A&Expires=1544180037&Signature=a9cbDJxTUfPP9LYzTMjL1ShB4%2FE%3D&response-con.
- Lang, Jon. 1992. "Symbolic Aesthetics in Architecture." In *Environmental Aesthetics*, 11-26. New York: Press Syndicate of the University of Cambridge.
- Leach, Neil. 2006. *Camouflage*. Cambridge: MIT Press.
- . 1999. *The Anaesthetics of Architecture*. Cambridge, MA: The MIT Press.
- Lew, Adina R. 2011. "Looking Beyond the Boundaries: Time to Put Landmarks Back on the Cognitive Map?" *Psychological Bulletin* 137 (3): 484-507. Accessed January 20, 2017. doi:10.1037/a0022315.

- Mackenzie, Andrew. 2014. "Rem Koolhaas: National Identity in Architecture." *Architecture Australia* (Architecture Australia) 103 (2). Accessed December 9, 2018. <https://architectureau.com/articles/national-identity-in-architecture-an-interview-with-rem-koolhaas/>.
- Marías, Julián. 1967. *History of Philosophy*. Translated by Stanley Appelbaum and Clarence Strowbridge. Mieola, NY: Dover Publications, Inc.
- Mayne, Thom, Stan Allen, and Morphosis Architects. 2011. *Combinatory Urbanism: The Complex Behavior of Collective Form*. Edited by Stephanie Rigolot. Culver City, CA: Stray Dog Café.
- McDonough, Thomas F. 1994. "Situationsist Space." *October* (The MIT Press) 67: 58-77. Accessed February 13, 2018. <http://www.jstor.org/stable/778967>.
- Medina, Dr. John. 2016. "Understanding How Our Brains Work Makes for Better Buildings." *nbbX* (NBBJ). Accessed December 9, 2018. <http://meanstheworld.co/well-being/understanding-how-our-brains-work-makes-for-better-buildings>.
- Meltzoff, Andrew, and Jean Decety. 2004. "What Imitation Tells Us About Social Cognition: A Rapprochement Between Developmental Psychology and Cognitive Neuroscience." In *The Neuroscience of Social Interaction*, edited by Christopher D Frith and Daniel M Wolpert, 109-130. New York: Oxford University Press.
- Meshberger, Frank Lynn. 1990. "An Interpretation of Michelangelo's Creation of Adam Based on Neuroanatomy." *Journal of the American Medical Association* 1837-1841.
- Mlodinow, Leonard. 2012. *Subliminal: How Your Unconscious Mind Rules Your Behavior*. New York: Vintage Books.
- Moscovitch, Morris. 2007. "Memory: Why the engram is elusive." In *Science of Memory: Concepts*, 16-22. New York: Oxford University Press.
- Mullinex, Ryan. 2018. "Neuroscience is Optimizing the Office." *nbbX* (NBBJ). Accessed December 9, 2018. <http://meanstheworld.co/work/neuroscience-is-optimizing-the-office>.
- Myers, David G. 2004. *Psychology*. 7th. New York: Worth Publishers.
- NAC. n.d. *NACLab*. Accessed December 9, 2018. <https://nacarchitecture.com/NACLab/default.aspx>.
- NBBJ. n.d. *nbbX*. Accessed December 9, 2018. <http://meanstheworld.co/>.

- NewSchool of Architecture and Design. n.d. *Certificates and Minors*. Accessed December 9, 2018. <https://newschoolarch.edu/academics/certificates-and-minors/professional-development/>.
- Nietzsche, Friedrich. 1957. *The Use and Abuse of History*. 2nd. Translated by Adrian Collins. New York: Macmillan Publishing Group.
- Nordh, Helena, Caroline Hagerhall, and Kenneth Holmqvist. 2013. "Tracking Restorative Components: Patterns in Eye Movements as a Consequence of Restorative Rating Task." *Landscape Research* 38 (1): 101-116. Accessed October 1, 2018. doi:10.1080/01426397.2012.691468.
- Nunnally, Brad, and David Farkas. 2017. *UX research: practical techniques for designing better products*. Beijing: O'Reilly Media. Accessed December 7, 2018. <https://www.safaribooksonline.com/library/view/ux-research/9781491951286/>.
- Oakley, David A., and Peter W. Halligan. 2017. "Chasing the Rainbow: The Non-conscious Nature of Being." *Frontiers in Psychology* 8: 1924. Accessed December 4, 2018. doi:10.3389/fpsyg.2017.01924.
- O'Doherty, John P. 2009. "Reinforcement Learning Mechanisms in the Human Brain: Insights from model-based fMRI." In *Neuroimaging of Human Memory: Linking Cognitive Processes to Neural Systems*, edited by Frank Röser, Charan Ranganath, Brigitte Röder and Rainer H. Kluwe, 46-63. New York: Oxford University Press.
- Oxford Dictionaries. n.d. *OxfordDictionaries.com*. Accessed May 22, 2018. <https://en.oxforddictionaries.com/>.
- Perkins+Will. n.d. *Eve Edelstien*. Accessed December 2018, 2018. <https://perkinswill.com/people/eve-edelstein>.
- . n.d. *Human Experience*. Accessed December 9, 2018. <http://research.perkinswill.com/labs/experience/#>.
- . n.d. *ideas+buildings*. Accessed December 9, 2018. <http://blog.perkinswill.com/>.
- . n.d. *Material Performance*. Accessed December 9, 2018. <http://research.perkinswill.com/labs/materials/>.
- . n.d. *Research*. Accessed December 9, 2018. <http://research.perkinswill.com/>.

- . n.d. *Transparency*. Accessed December 9, 2018. <https://transparency.perkinswill.com>.
- Perry, Marvin, Joseph R Peden, and Theodore H Von Laue. 2006. *Sources of Western Tradition*. New York: Houghton Mifflin Company.
- Phillips, Patricia C., James Wines, and Site, Inc. 1982. *Highrise of Homes*. New York: Rizzoli.
- Plato. 2004. *Republic*. Translated by Benjamin Jowett. New York: Barnes & Noble Classics.
- Purves, Dale, George J. Augustine, David Fitzpatrick, William C. Hall, Anthony-Samuel LaMantia, James O. McNamara, and S. Mark Williams, . 2004. *Neuroscience*. Third. Sunderland, MA: Sinauer Associates, Inc.
- Salk, Jonas. 2008. "The Next Evolutionary Step in the Ascent of Man in the Cosmos." *Leonardo* 41 (3): 279-286. Accessed June 18, 2018. <https://www.mitpressjournals-org.offcampus.lib.washington.edu/doi/10.1162/leon.2008.41.3.279>.
- Sapolsky, Robert M. 2017. *Behave*. New York: Penguin Press.
- Scranton, Lauren. 2018. "Architecture + Human Behavior: Strategies for Enhanced Wellbeing in Residence Halls." *NACLab* (NAC). Accessed December 9, 2018. <https://nacarchitecture.com/NACLab/architecture-plus-human-behavior.aspx>.
- Shammas, Masood A. 2011. "Telomeres, lifestyle, cancer, and aging." *National Health Institute - Public Access* 28-34. doi:10.1097/MCO.0b013e32834121b1.
- Smith, Steven M. 2007. "Context: a reference for focal experience." In *Science of Memory: Concepts*, 111-114. New York: Oxford University Press.
- Speaks, Michael. 2010. "Design Intelligence Part 1: Introduction." In *Constructing a New Agenda: Architectural Theory 1993-2009*, edited by A. Krista Sykes, 206-2017. New York: Princeton Architectural Press.
- Starr, G. Gabrielle. 2013. *Feeling Beauty the neuroscience of aesthetic experience*. Cambridge, MA: The MIT Press.
- Stevens, Francis L., Robin A. Hurley, and Katherine H. Taber. 2011. "Anterior Cingulate Cortex: Unique Role in Cognition and Emotion." *Windows to the Brain* 23 (2): 120-125. Accessed December 12, 2018. <https://neuro.psychiatryonline.org/doi/pdf/10.1176/jnp.23.2.jnp121>.
- Tarnas, Richard. 1993. *The Passion of the Western Mind*. New York: Ballantine Books.

- Tulving, Endel. 2007. "Coding and Representation: SEarching for a home in the brain." In *Science of Memory: Concepts*, 65-68. New York: Oxford University Press.
- U.S. Green Building Council. n.d. *Interior Lighting - Quality*. Accessed December 9, 2018. <https://www.usgbc.org/credits/new-construction-core-and-shell-schools-new-construction-retail-new-construction-healthca-36>.
- University College London. n.d. *Space Syntax*. Accessed December 10, 2018. <http://otp.spacesyntax.net/>.
- UNSense. n.d. *UNSense*. Accessed December 9, 2018. <http://unsense.com/>.
- Usrey, W. Martin, and Henry J. Alitto. 2015. "Visual Functions of the Thalamus." *Annual Review of Vision Science* 351-371. Accessed October 11, 2018. doi:10.1146/annurev-vision-082114-035920.
- Usunoff, Kamen G., Oliver Schmitt, Nikolai E. Lazarov, E. Dimitar Itzev, Arndt Rolfs, and Andreas Wree. 2008. "Amygdala and Subcortical Vision: Recognition of Threat and Fear." *Biomedical Review* 19: 1-16. Accessed November 16, 2018.
- Vartanian, Oshin, Anjan Chatterjee, Helmut Leder, Nicolai Rostrup, Gorka Navarrete, Lars Brorson Fich, Cristián Modroño, Martin Skov, Marcos Nadal, and Guido Corradi. 2017. "Preference for Curvilinear Contour in Interior Architectural Spaces: Evidence from Experts and Nonexperts." *Psychology of Aesthetics, Creativity, and the Arts*. Accessed October 1, 2018. <http://dx.doi.org/10.1037/aca0000150>.
- Velux. n.d. *Daylight Requirements in Building Codes*. Accessed December 9, 2018. <https://www.velux.com/deic/daylight/daylight-requirements-in-building-codes>.
- Venturi, Robert. 1996. *Iconography and Electronics upon a Generic Architecture: a view from the drafting room*. Cambridge, MA: The MIT Press.
- . 2008. "Viva Mannerism for Architecture for our Age." *Log* (13/14): 152-153.
2015. "Wikimedia Commons." *File: Dopaminergic pathways.svg*. October 22. Accessed December 12, 2018. https://commons.wikimedia.org/wiki/File:Dopaminergic_pathways.svg.
- Woods Bagot. n.d. *ideas*. Accessed December 9, 2018. <https://www.woodsbagot.com/ideas>.
- . n.d. *Superspace | Enterprise | Woods Bagot*. Accessed December 9, 2018. <https://www.woodsbagot.com/enterprise/superspace>.

Woods, Lebbeus. 2009. "Same Difference." *Lebbeus Woods Blog*. Accessed November 30, 2018.
<https://lebbeuswoods.wordpress.com/2009/01/13/same-difference/>.

ZGF. n.d. *Process*. Accessed December 9, 2018. <https://www.zgf.com/process/>.