

re:Engineered

Exposing the the Architectural and Environmental Possibilities of
New Structural Wood Composites

Jon Haufe

A thesis submitted in partial fulfillment of the
requirements for the degree of

Master of Architecture

University of Washington
2012

Committee:

Brian McLaren

Kimo Griggs

Program Authorized to Offer degree:

Architecture

TABLE OF CONTENTS

	Page
List of Figures.....	ii
Thesis Statement.....	1
Introduction.....	2
EWP Development and Production.....	8
Harvesting and Existing Supply.....	18
A New Era of Engineered Wood.....	24
Case Studies.....	28
Site Selection and Location	30
Daylight and Zoning.....	37
Massing and Circulation.....	38
Structural System.....	44
Conclusions.....	54

LIST OF FIGURES

Number		Page
1	Carbon in USFS Western Washington Forests.....	3
2	Oriented Strand Board.....	10
3	Laminated Strand Lumber.....	11
4	OSB Production Energy by Subprocess.....	13
5	Total Production Energy by product.....	14
6	Wood Waste Data.....	21
7	Cross Laminated Timber.....	26
8	The Statdhaus.....	28
9	North Vancouver City Hall.....	29
10	Site Vicinity Aerial Photo.....	30
11	Site Aerial Photo.....	31
12	Site Section.....	34
13	City Grid Shift.....	36
14	Solar Shadow Range Study.....	37
15	Solar Path Studies.....	37
16	Site Perspective.....	38
17	Circulation Diagram.....	39
18	Massing Diagram.....	41
19	Truss Assembly Diagram.....	44
20	Structural System.....	45
21	South Elevation.....	46
22	Building Section.....	46
23	West Elevation.....	46
24	Plans.....	47
25	Section Perspective.....	49
26	Interior Rendering.....	50
27	Elevation Rendering.....	51
28	Exterior Rendering from Top Floor.....	53
29	Exterior Rendering from Hamlin Street.....	55
30	Exterior Rendering from Fairview.....	57

THESIS STATEMENT

While wood is indisputably the most sustainable building material used in the Built Environment, very little of it is recycled at the end of a building's life. Although both lumber quality and supply continue to decline annually, we persist with our view of wood only as a disposable commodity that is more easily replaced than recycled. This thesis rethinks the ways we create, use, and ultimately dispose of wood and Engineered Wood Products (EWPs) and highlights the many inherent advantages - both existing and potential - that future Engineered Wood Products might offer in an architectural context. The use of recycled waste wood fiber in EWP's could eliminate the most energy intensive portions of the production process. The development of recycled supply streams would relieve pressure on our forests, allowing them to better fulfill their carbon sequestering potential. As engineered wood products are refined through more frequent and varied application, their identity as wood elements evolves as well. In addition to addressing the environmental possibilities of engineered wood products, this thesis aims to investigate the potential implication of this evolution on the aesthetic and tactile possibilities and the perceptions of engineered wood composites.



INTRODUCTION

Environmentally speaking, it is hard to argue against the use of wood as a building material. In fact, from a carbon footprint standpoint, wood is indisputably the most environmentally sensitive building material currently in wide use in the built environment. As forests grow, trees process carbon dioxide through photosynthesis, sequestering carbon from the atmosphere within their wood. As forests fully mature over a century or more, the volume of carbon sequestered within them also grows steadily until they reach a point of relative stasis where large mature trees begin to die and decompose, releasing their sequestered carbon at a rate roughly equal to the volume of carbon being sequestered by new trees growing in their place. This optimal carbon plateau lies many decades beyond the 20-to-60 year harvest cycle that is currently typical of our agriculturally managed forests. In this way, a forest might be viewed as a sort of Carbon Battery which collects and stores carbon en masse for discharge into the atmosphere at some later date. Our suboptimal harvest cycle then is akin to charging these batteries to only half or less of their actual capacity prior to harvest.

This inefficiency in our current approach is important to note when viewing wood as a building material because

Carbon in USFS Western Washington Standing Inventory - by age.



FIGURE 1: As shown by this data from USFS forests in Western Washington, young forests sequester increasing levels of carbon until a forest reaches a level of maturity where carbon is being released at relatively the same rate as it is being retained. Our short harvest cycle currently cuts short the carbon sequestering potential of our forests. (Source: USFS Forest Inventory and Analysis Data.)

carbon sequestered by trees during their lifetime is subsequently transferred into the built environment when wood is used as a construction material, where it is stored for the life of the structure. Using the metaphor of the Carbon Battery, harvest essentially removes these “batteries” from the natural environment at whatever stage of “charging” they may have reached, and relocates them into the built environment for long-term storage. Meanwhile, in the forest, new trees begin sequestering carbon in their place, creating a potentially perpetual aggregation cycle of sequestration and storage of atmospheric carbon within the built environment. Thus, by using wood as a building material we can systematically reduce atmospheric carbon. No other building material exhibits this positive carbon footprint.

Concrete, Steel, and other manmade building materials require significantly more energy in their production than wood. The burning of fossil fuels required by these production processes adds significant new carbon into the atmosphere creating a negative carbon footprint regardless of how much carbon might be contained within the finished material. With wood, only at the end of a wood building’s life does its sequestered carbon begin to reenter the atmosphere through either combustion or slow decomposition in a landfill. Unfortunately, while the opportunity is

ripe to extend the storage of carbon through the reuse or recycling of wood fiber at the end of a building’s life, in actuality very little of the wood used in the built environment is recycled on any meaningful scale today.

With the average lifespan of buildings steadily shrinking over recent decades and considering the concurrent geometric growth of the built environment, we have long been outstripping the effective renewal rate of our supply of high-quality, structural grade lumber. Although both lumber quality and supply continue to decline annually, we persist with our view of wood only as a disposable commodity that is more easily replaced than recycled. By doing so, we ignore the vast potential for optimization inherent in this cycle.

Further complicating this issue, our main answer to diminishing lumber quality and supply over the past three decades has been the rapid development of a wide array of Engineered Wood Products. By taking advantage of former waste materials like small-diameter coincidentally-harvested trees or structurally deficient species, these products often exhibit significant structural and economic advantages over conventional solid-sawn lumber. However, these engineered products require vastly more energy to

produce than sawn lumber, greatly reducing the inherent positive carbon advantages of using wood. Paradoxically, they also effectively reduce the available quality of solid-sawn lumber even further by creating an incentive for lumber producers to harvest immature forests on an ever-shorter harvest cycle, knowing that they now have a profitable alternate use for otherwise unusable small diameter trees. In this way, our accelerated use of EWP's further erodes the benefit of wood's nature as a carbon mitigating renewable resource by allowing immature forests to be harvested long before their vast carbon sequestering potential has been realized.

While being mindful of these inefficiencies, this thesis will focus on rethinking the ways we currently create, use, and ultimately dispose of wood and Engineered Wood Products in the built environment. It will explore the current processes involved in producing and utilizing wood products – and particularly Engineered Composite Wood Products – with the intention of identifying, exposing, and exploiting the significant inefficiencies that currently exist in our supply systems as well as highlight the many inherent advantages - both existing and potential - that EWP's offer in an architectural context.

To facilitate these goals, this thesis proposes a new mixed use building in the Eastlake neighborhood of Seattle. This project will strive to express both the potentially unique aesthetic and tactile possibilities offered by Engineered Wood Composite materials as well as demonstrate the flexibility and efficiency that might be offered by a novel engineered composite wood structural system. It will further strive to establish the potential energy and carbon savings that could be realized by incorporating recycled wood fiber in existing and future Engineered Wood composite technologies.

EWP DEVELOPMENT AND PRODUCTION

While the carbon benefits of increasing our use of wood in buildings are clear, the path to sustainably supplying more wood from our existing forests is less so. The days of easy harvest of abundant, high-quality, old-growth timbers have long since faded. In today's world the harvest of virgin stands of timber is fraught with financial, political, social, and even emotional complications. The former pace of harvest of old growth timber is now widely understood to be unsustainable. And, as a result of the rate of our consumption of this resource, especially over the past century, the quality – if not quantity - of softwood timber available to the building industry has been in decline for decades.

Forests exploited for wood production today have typically been harvested numerous times since the virgin stands were first cut. These agriculturally managed forests are harvested on a cycle of anywhere from 20 – 60 years, depending on their type and geographic location, producing significantly smaller and more rapidly grown wood than was once typical of old growth forests, whose trees were more typically hundreds of years old.

To augment the volume and structural capacity of

these reduced harvests, lumber producers have developed an increasingly diverse quiver of engineered lumber products (or EWP's.) Structural Composite beams, I-joists, lumber, and sheet goods are increasingly common today, in both residential and commercial scale construction. These engineered wood products typically perform better and are more structurally predictable than conventional solid sawn timber. What's more, Engineered Wood Products are most often produced using wood fiber that is a by-product or waste product from other production and harvest processes.

The main trade-off for these sometimes revolutionary products, however, is that the energy required to produce Engineered Wood Products – and thus their carbon footprint - is typically significantly higher than what was previously required in the manufacture of their equivalent solid-sawn counterparts. However, as old-growth trees have become increasingly scarce and the act of harvesting them has grown ever more riddled with political and environmental hurdles that producers must navigate; lumber companies increasingly turn to these engineered alternatives despite their compromised environmental profile.

The first composite Engineered Wood product developed



for broad-scale use was Oriented Strand Board (OSB.) It has since become arguably the most ubiquitous. OSB is a structural sheet material composed of consistently-sized flakes of adhesive-soaked wood fiber which are pressed in alternating layers, oriented with the grain of the wood flakes in each layer opposing one another. These layers are then pressed and heat-cured into solid, structurally predictable panels. OSB was originally developed and marketed in the 1970's as an alternative for veneer-based plywood for applications such as wall and roof sheathing and subfloors. It was also developed, in part, to create a profitable use for the increasingly smaller and otherwise unusable trees that were being coincidentally harvested while cutting the less mature agriculturally grown forests that were becoming the norm. (Kline, p74)

In addition to its common usage as a substitute for veneer-based plywood, many other uses have been developed for OSB over the past three decades. It is commonly used as web material for I-joists, as structural skins for SIPs (Structural Insulated Panels,) and as structural rim board. Following the success of OSB as a versatile construction material, producers began looking for other opportunities for engineered composites, developing Laminated Strand Lumber (LSL) and, later, Parallel Strand Lumber (PSL.)

FIGURE 2: Oriented Strand Board was developed in the 1970's in part to create a market for otherwise unmarketable wood byproducts. It is widely used in the manufacture of other Engineered wood products such as Structural Insulated Panels and as webs for TJI's.

LSL production and composition is similar to that of OSB. LSL material is formed of mats of wood flakes oriented in parallel rather than opposing layers. The flakes used in LSL are typically slightly longer and more consistent than those used in OSB production. Instead of being pressed into sheets of a finished nominal thickness, LSL material is heat-pressed into large billets at the end of the production process. These billets are then sawn into usable beams or boards as necessary. LSL is commonly sawn into nominally-sized dimensional lumber marketed as a structurally consistent alternative to solid-sawn lumber for use as framing in traditional or advanced stick-framing systems. Alternatively, it is sawn into beams in nominal dimensions that match heavy timber profiles and is marketed as an economical but structurally consistent alternative to solid-sawn heavy timber or glue-laminated beams.

OSB and LSL production begin with the grinding or flaking of feedstock – or raw material – that are typically called “green wood rounds.” Green wood rounds are essentially the trunks of small trees, including the bark. This source material is “green” at the beginning of the process, meaning it is fresh-cut “live” wood that has not been seasoned or dried in any way prior to entering



FIGURE 3: Laminated Strand Lumber is similar in composition to OSB, but with layers oriented parallel with one another. Commonly it is used for beams and headers, but the large billets in which it is manufactured are suitable for large panelized structural systems as well. (Images from Weyerhaeuser)

the mill. The moisture content of the green round feedstock is similar to that in live standing trees. A moisture content of more than 50% is typical. To reduce the moisture content of this extremely wet feedstock to a level that is acceptable for OSB production (in the range of 15-20%) these wet wood flakes require significant kiln-drying. This kiln-drying of green log flakes requires massive quantities of heat energy.

The energy required for most lumber production, OSB, LSL, and other engineered products included, is provided largely by biomass fuel. The biomass fuel in this case consists mainly of green waste wood material – ground up limbs and bark that have been recently removed from the green wood rounds. Because this biomass fuel source is as wet as the green rounds themselves, it is a tremendously inefficient fuel. In practice, the standard applied for the heat value of this “50% wet basis” biomass fuel is a mere 67% combustion efficiency (Kline, 78).

This fuel, however inefficient, is on hand, abundant, and essentially free of monetary cost to the production plant. While operating this way may be financially expedient for EWP producers because the fuel is essentially a waste product from the process, it represents a gross inefficiency that is ripe for exploitation in the

pursuit of achieving a more environmentally feasible alternative to conventional engineered lumber.

As a general basis for comparison, typical OSB production uses approximately three times the energy to produce a cubic meter of finished material when compared to kiln-dried solid-sawn lumber (Lippke, 7). If we exclude harvest and transportation and look at the production process for OSB (and by extension, LSL) from the time the raw material arrives at the plant, production can be divided into 4 basic stages:

- 1 – Log handling and Flaking
- 2 – Drying and Screening flakes/strands
- 3 – Blending with resins, mat formation, and pressing/heat curing
- 4 – Finishing, cutting, packaging

The vast majority of energy used in the production of these composite engineered wood products is heat energy provided by this inefficient “wet basis” biomass fuel. When examining this production process critically, what is vital to note is that fully 80% of the total heat energy used in the entire process is used in Step 2, and specifically in the kiln-drying process. The remainder of the heat energy is applied in step 3 (Kline, 77). While the heat

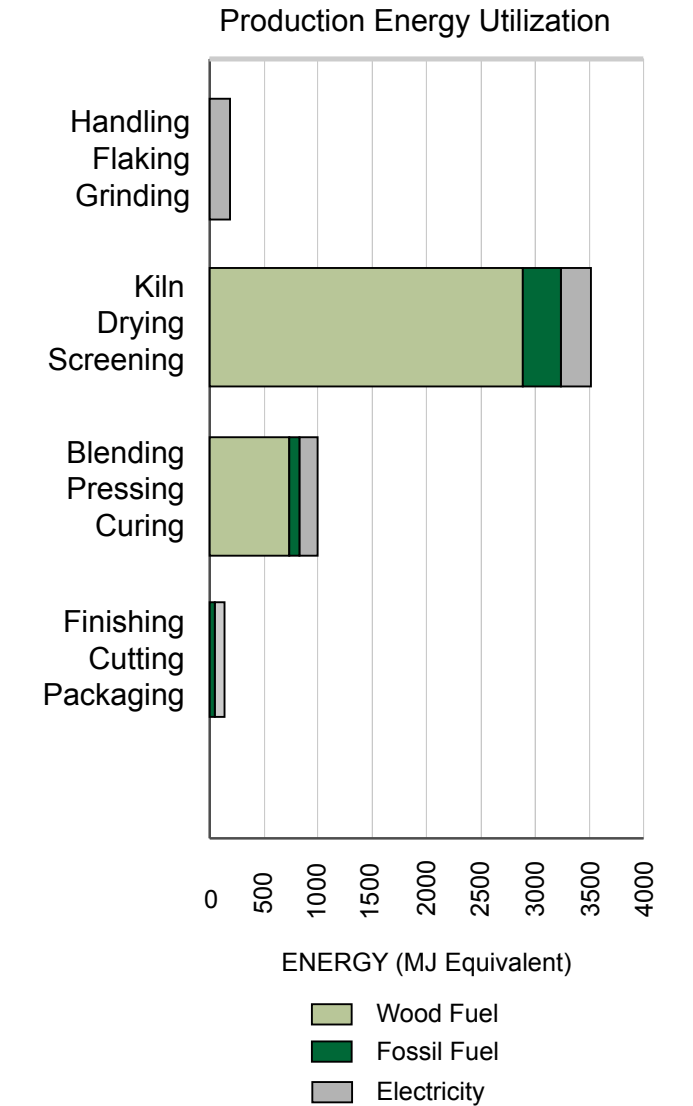

FIGURE 4: 80% of heat energy used in production of OSB is used in the drying of raw materials using biomass fuel. (Data from Kline.)

Total Energy Used in Production (MJ/Cu. Meter)

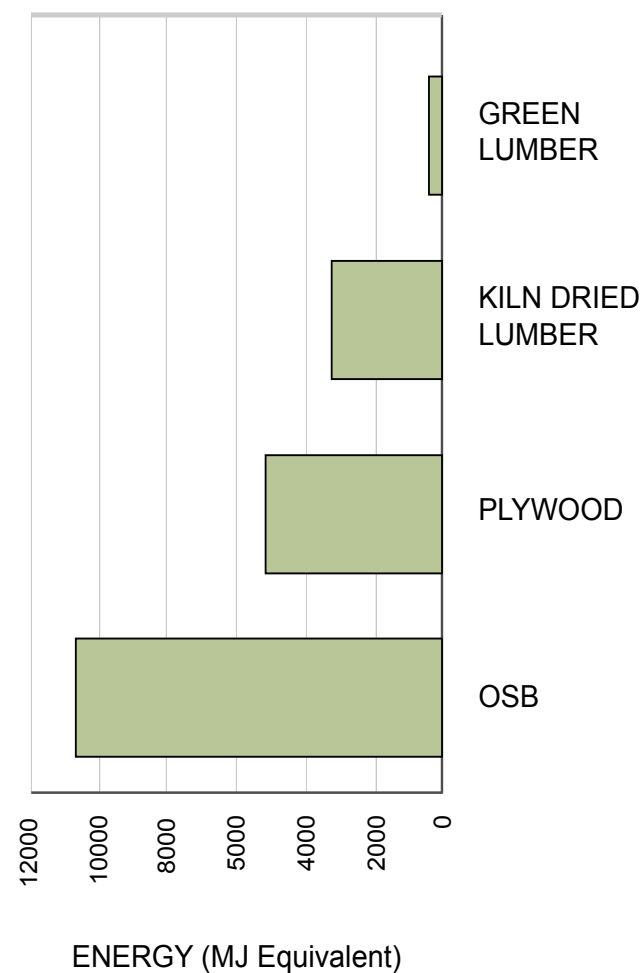

FIGURE 5: OSB produced conventionally, using 50% wet basis fuel and feedstock, consumes more than three times the energy required to produce an equivalent volume of kiln-dried solid-sawn lumber. Dry fuel and feedstock have the potential to significantly reduce the energy and carbon profile. (Data from Lippke et al.)

energy required to press and cure the finished product in step 3 is unavoidable, at least with current adhesive technologies, the energy required to dry the green feedstock could hypothetically be substantially reduced or omitted entirely by using feedstock with a starting moisture content more compatible with the process. Essentially, this data shows us that up to 80% of the total heat energy required for production is available for omission simply by using dry feedstock.

To quantify the energy used in these stages, approximately 7412 MJ (Mega-Joules) of heat energy are required to produce one cubic meter of conventionally manufactured OSB (Puettmann/Wilson, 23-24). If we were to assume that we could reduce the energy required to produce OSB by 80% by completely omitting the kiln-drying stage we arrive at 1482 MJ to produce a cubic meter of material. Of course, it is not possible to know that we could reduce this total by a full 80% in actual practice, and I don't pretend to expect that we might. But, for the sake of comparison, kiln-dried solid-sawn lumber requires approximately 3,175 MJ of energy to produce one cubic meter of material. What we can reasonably assume, then, is that it is feasible that by using a dry feedstock in the production of engineered composite lumber products we could potentially produce these structurally superior

engineered composite materials while expending less energy than we currently use to produce kiln-dried solid-sawn lumber. Furthermore, the remaining 20% of heat energy required in Step 3 of the process could be slashed as well, by using a more efficient dry biomass fuel source in place of the 50% wet basis fuel currently used.

So, then, all we need to do is identify a new supply source for feedstock and biomass fuel that is dry. Acquisition of this new feedstock and fuel brings me to the second major inefficiency in the way that EWPs are currently produced. Right now there is virtually no recycling market whatsoever for wood waste from construction and demolition. Virtually all wood construction and demolition waste currently goes directly into landfills. But, if we were to redirect this waste stream, wood that might be reclaimed from the built environment would be a suitable dry source and fuel material.

Having stood inside a building for many years, wood waste from demolition would be a naturally dried source of wood fiber. Waste diverted from construction waste – end cuts, culled lumber, false work, etc. -- would also be a dry source, as virtually all this waste is lumber that has already been kiln-dried or substantially

air-dried during its original production process. Because these waste materials have been previously dried on an intracellular level, even if these recycled wood materials were not stored dry before being used in OSB production, they would not approach the moisture content of green wood rounds. Once wood has been kiln-dried or air-dried by being “seasoned” over a period of time, the wood’s intracellular moisture is gone. The dry lumber is no longer capable of absorbing anywhere near the amount of moisture that green lumber typically holds.

Because of this, even kiln-dried or seasoned lumber that becomes saturated again with water might exhibit moisture content in the range of 20-25% and would require a much lower level of energy to dry to the material to a level suitable for use as source material for engineered wood products. By contrast, the green rounds that are used currently as feedstock and fuel in OSB and LSL production are assumed to have a minimum 50% moisture content upon entering the kiln, and in practice are often much higher. (Citation needed. Kline?)

This relatively dry, recycled source material would result in a significantly streamlined and more energy efficient manufacturing process. What’s more, the redirection of the considerable wood

construction waste stream could have the potential to augment our current supply of EWP source material enough to eventually allow us to begin to reverse our shortened modern forest harvest cycle. Not only would the carbon contained in all that recycled waste wood be reinserted immediately back into the built environment for continued storage with a minimal level of additional processing, but at the same time we could allow forests to further mature and approach their optimal levels of carbon sequestration before being harvested.

HARVESTING AN EXISTING SUPPLY

To understand how successful this approach could be, we need to understand how much wood fiber we might expect to extract from a redirected waste stream as well as how waste wood fiber might be used to replace virgin fiber in new or existing Engineered Wood Products. First, the matter of volume available in existing waste streams will be addressed.

The EPA estimates that each year in the United States approximately 4.3 lbs. of construction waste are generated for each square foot of new residential construction. Roughly 65% of this construction waste is wood. As these numbers don't include renovation or demolition waste, this waste consists almost entirely of clean, dry wood material in the form of culled lumber, bracing, end cuts, false work, and other construction site waste exclusive of demolition.

Translated, just in the realm of new construction alone, somewhere in the ballpark of 4.26 million tons of mostly-clean wood enters the waste stream annually (EPA 2003, 9). Currently, virtually all of this material goes into landfills. A miniscule fraction of this waste – less than 1% -- is burned in energy plants.

These “hog fuel” energy plants exist in only a few select cities and generally contribute only a small portion of those cities' total energy requirements. While wood in a landfill continues to sequester carbon and act as a carbon sink for as long as it takes that wood to biodegrade, it is wasteful to remove this still-useful wood fiber from the built environment and deposit it in a landfill to be returned to the atmosphere prematurely.

While this construction waste represents a large potential volume of harvestable wood fiber, its volume is dwarfed by that of waste generated through residential demolition and renovation annually. In the U.S. the EPA estimates that we generate nearly 115 pounds of waste for each square foot of residential construction demolition or renovation undertaken, with roughly 45–55% of this waste being wood. (EPA 2003, 11-12) This amounts to nearly 10 million additional tons of wood fiber that is discarded annually as a result of residential construction demolition waste. Virtually none of this demolition waste is burned for fuel or recycled in current practice.

Combining these two waste streams demonstrates the existence of a vast and virtually untapped source of recyclable wood fiber. Together they represent more than 14.25 million tons of

waste wood fiber on an ongoing annual basis. And, it is important to note, these numbers represent only totals from residential construction, renovation, and demolition and don't even take into account the even larger volume of waste generated annually through commercial construction and demolition pursuits.

For a comparison of what this volume of wood represents, we can look at U.S. Forest Service harvest figures from 2008. Using the generally accepted "Doyle Conversion Rate" of 8 tons of usable wood per thousand board feet (MBF) harvested, the total timber harvest from U.S. Forest Service land for fiscal year 2008 was in the neighborhood of 16.4 million tons. (USFS FIA)

To clarify: we currently direct nearly as much wood fiber into landfills each year as we subsequently allow to be harvested from *all* U.S. Forest Service managed public lands combined. What's more, not only does the wood we are throwing away have the potential to substantially offset our need to harvest new wood, it could allow us to make new engineered wood products such as OSB and LSL at a substantially lower energy, carbon, and pollution cost.

To summarize, three main inefficiencies have been

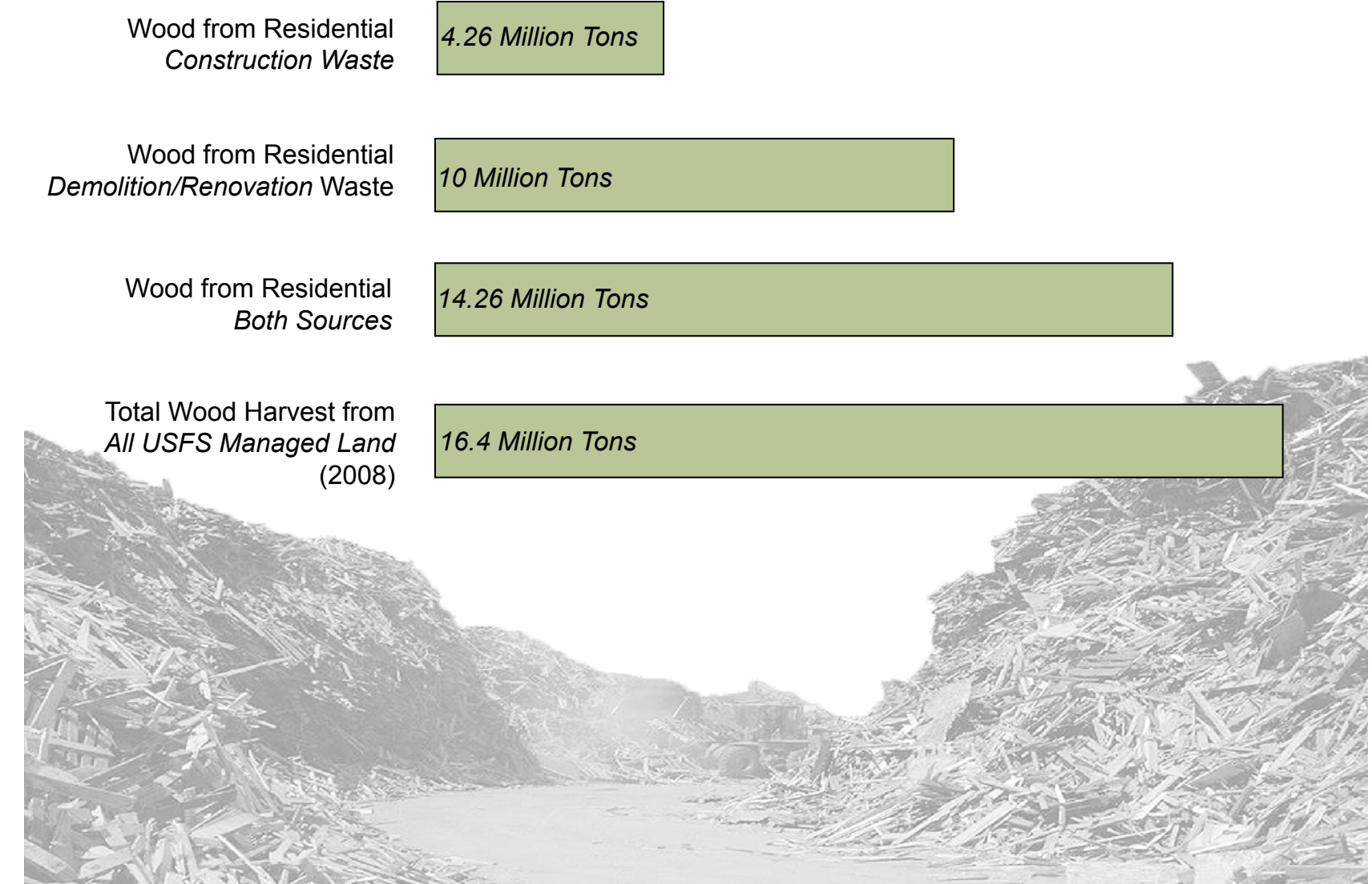

FIGURE 6: By an EPA estimate, each year nearly as much wood waste goes into Construction and Demolition Waste Landfills by volume as is harvested from US Forest Service Lands nationwide. This data represents only waste from Residential construction pursuits and not waste from the considerably larger Commercial construction realm. (Date from EPA and USDA/USFS.)

discussed in the way we currently produce and use EWPs which might be addressed through the replacement of green wood round feedstock with recycled dry wood. First, the vast majority of heat energy required in the production of structural composite wood materials such as OSB and LSL is expended in the kiln drying of wet feedstock. This inefficiency is further exacerbated by the fact that the fuel being used to accomplish this is also from the same wet source.

The second issue is that there is currently no meaningful recycling of wood products from construction and demolition practices. This means that we are discarding massive amounts of usable wood fiber each year, as well as the carbon contained within that wood, simply because we view wood as a renewable resource that need not be reprocessed. Reuse of this waste stream is well within our technological capacity, and could provide an impactful volume of wood fiber with the potential to considerably alter the pace at which we harvest new timber.

Which touches on the third issue; we currently harvest our agriculturally managed forests on a foreshortened timeline that truncates those forests' optimal capacity to sequester carbon. By taking advantage of recycled fiber and reducing the incentive to

harvest forests on an ever-shorter timeline we could extend this harvest cycle towards the optimal sequestration plateau, and allow our forests to store even more carbon before transferring that carbon into the built environment.

A NEW ERA OF ENGINEERED WOOD

The ability to produce engineered composite wood products at an energy and carbon output similar to that of solid-sawn wood might just solve engineered composite wood's most glaring weakness. There has been something of an awakening in recent years to the structural possibilities represented by these products. New production capabilities and a renewed focus on creative design and engineering have begun to stretch the boundaries of what these materials can be used for. While countries in Europe have historically lead much of the research into new architectural uses for wood and Engineered Wood Products, much of this recent work has also been undertaken in British Columbia, Canada in the past decade.

In fact, in the interest of demonstrating their belief in the use of wood as a building material, the government of British Columbia passed the "Wood First Act" in 2009, which requires all provincially funded building projects be constructed primarily of wood. The stated purpose of this act is "to facilitate a culture of wood by requiring the use of wood as the primary building material in all new provincially funded buildings" (Wood First, Bill 9-2009). The result of this legislative step has been a groundswell

of innovation in wood construction and an explosion in the scale of buildings being planned and undertaken utilizing wood as the primary structural and aesthetic element.

Many different forms of Engineered Wood Products have been featured in this wave of new wood buildings – a wave that includes almost all new buildings built for the 2010 Winter Olympics in Vancouver, BC. However, one new form of EWP that has emerged and been rapidly developed which promises to be capable structurally of supporting very large buildings in the future is Cross Laminated Timber (or CLT.) CLT systems consist of large solid slabs or panels made up of structurally graded boards arranged in alternating layers with the grain of the wood opposing itself on each layer. The concept is similar to the structural composition of an OSB panel, where alternating layers of grain create a dimensionally stable panel that performs structurally in both directions due to the alternating strength axes of its layers.

Construction of buildings using CLT panels is often similar to building with pre-cast concrete structural systems more so than it is to traditional wood framing systems. The large panels – in some cases up to 50' in length and anywhere from several inches to several feet in thickness – are prefabricated off-site on



specially designed mills and presses. The panels are individually constructed, shipped to the site, and then assembled with the help of cranes. Compared to concrete construction, these wood panels can achieve similar strength as concrete slabs but at 60% of the weight of concrete and only 80% of the bulk (KLH). (For example, an 8” thick CLT floor slab might achieve a similar span as a 10” thick reinforced concrete slab. But this CLT slab would weigh only 60% as much as an 8” concrete slab might.) The implications of this superior strength-to-weight ratio are profound. Buildings as tall as 9 stories have already been built successfully using CLT systems, and engineers have demonstrated that buildings of 30 stories or taller are not out of the realm of possibility.



FIGURE 7: Cross Laminated Timber construction consists of large, solid wood panels composed of alternating layers of wood bonded with adhesives under pressure. Buildings are prefabricated and assembled in much the way a prefabricated concrete structural system might be.

While this thesis will not explore a tall or mid-rise building, CLT building methods are a marker of where the cutting edge of EWP technology currently lies. As we think about the ways that wood might be used in the future to reduce the carbon impact of our built environment, these structural capabilities are important to understand. It is also important to understand each of the driving forces behind these developments. While CLT might exhibit a significant carbon savings over concrete construction, it also may not be viable on a large scale from a resource standpoint.

CLT, as it exists today, is made up of solid-sawn timber. If it were possible, and we suddenly began replacing all mid to large scale concrete construction with CLT methods, we might expect to quickly find the planet wholly denuded of usable timber. In fact, one reason that CLT building methods have found traction in British Columbia in recent years is that the province finds itself flooded with a glut of timber that must be used in the short term as the result of a massive and unusually broad infestation of bark beetles in BC’s coastal forests. If this “beetle-kill” timber is not used within several years, it will begin to rot in place and will go to waste before long. (mgb, 9)

This short term wealth of timber makes the prospect of CLT systems even more enticing for British Columbia, even though those advantages may not fully translate to a world scale. CLT is explicitly mentioned, however, because the concept shows tremendous potential. How might the structural concept of large, solid, cross-laminated wood panels be more successfully exploited if those panels were able to be made of a nearly endless supply of recycled wood instead of full grown trees? What if the energy required in the manufacture the panels was reduced at the same time?

CASE STUDIES

The Stadthaus

Murray Grove, London, England.

Completed: 2008

Waugh Thistleton Architects

Perhaps the most iconic representation of Cross Laminated Timber construction to be completed so far is The Stadthaus apartment building in London. Completed in 2008, the Stadthaus is a 9 story residential building that is constructed entirely of wood. CLT panels make up floor and wall plates as well as the structural core and elevator shafts of the building. Since its completion, the UK has based the move to alter building codes to allow additional tall wood buildings on the Stadthaus' success. The structure will store over 181 tons of carbon within the wood comprising it. Due to the prefabricated nature of the CLT panel system, the entire building was assembled on site in less than 9 weeks, a considerable time and cost savings over a comparable concrete or steel framed structure (Detail).

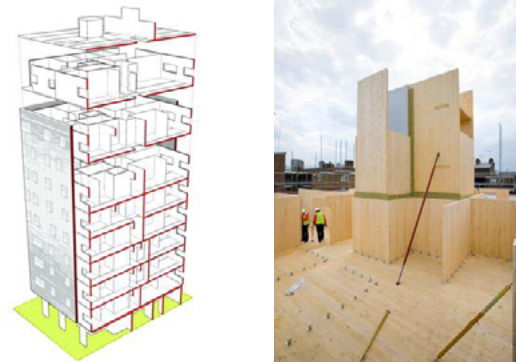

FIGURE 8: The Stadthaus, Murray Grove, London. The tallest all- wood building in the world. Framed with CLT.

City Hall and Civic Center

North Vancouver, BC.

Completed: In progress/2012

mgb Architecture+Design

An addition and renovation of the North Vancouver City Hall demonstrates the potential to hybridize the concepts of Cross Laminated Timber and Structural Wood Composite materials. The roof of the long atrium spans approximately 30 feet between walls and is composed of built-up cross laminated panels of LSL. The LSL is exposed on the under side, acting as the finished ceiling on the interior where it conceals lighting, HVAC, and sprinkler systems within a 7" void between the LSL strips that form the bottom layer of the layup. The panels that make up the system are 30' in length, 12' wide, and 14" deep including the 7" void. This project demonstrates the ability of Structural Wood Composite assemblies to span considerable distances between supports with a relatively thin section. The prefabricated building went together quickly using cranes to set the large panels in much the same way that a CLT system is assembled.



FIGURE 9: North Vancouver City Hall renovation combines CLT principles with LSL technology. Large panels are built of cross laminated sheets cut from LSL billets. It is a multi-faceted solution that spans 30', operates a finished interior, is integrated with the gravity supports, simplifies construction, and thinks differently about opportunities for Engineered systems. (Images: mgb Architecture+Design)

SITE SELECTION AND LOCATION

The site for this project is in the Eastlake neighborhood of Seattle adjacent to the eastern shore of Lake Union. It is a long narrow site approximately 425 feet in length North to South and just 85 feet in East/West depth. At the southwest corner lies the intersection of East Hamlin Street and Fairview Ave East. The site sits directly across Fairview Ave East from the Lake Union shoreline.

Directly west across Fairview Ave East from sits the single story waterfront office building and parking lot for Ward's Cove Packing Company. Also on the Ward's Cove site, set partially on pilings over the water immediately to the west of this office building is an additional two story office and recreational building which serves a 10 slip marina for large (75 to 100 foot long) motor yachts. Also on the water at the north half of the Ward's Cove property are a set of docks forming a dozen slips that are being sold and developed for floating homes, several of which are already built and occupied as of early 2012.

This Ward's Cove residential development, which has been realized in just the past couple of years, is representative

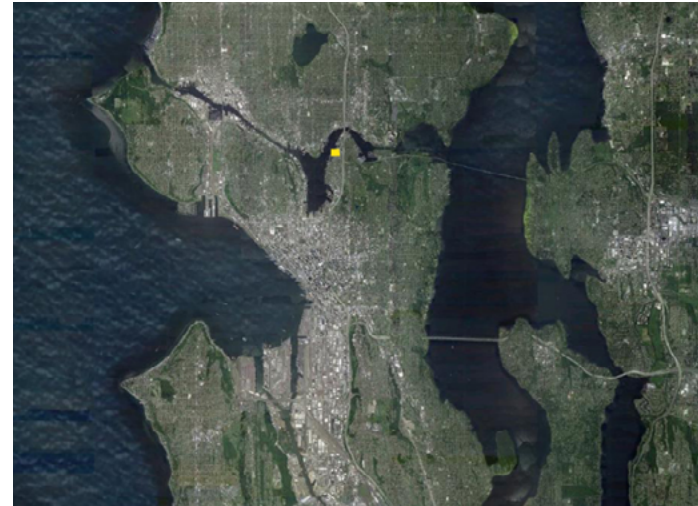

FIGURE 10: Aerial view of Seattle area showing location of the site in the Eastlake neighborhood in yellow.



FIGURE 11: Aerial photo showing the site in yellow box. Directly across Fairview Ave East, on Lake Union is the Ward's Cove development, houseboat piers, and yacht moorage. Green space to the north is a small park and Pea Patch area. The neighborhood is hemmed in by the I-5 barrier to the east and the tapering shore of Lake Union.

of the recently changing neighborhood surrounding the site. Historically, this neighborhood has been a somewhat gritty mix of industrial waterfront and smaller scale residential buildings. For most of the past century, in fact, Ward's Cove Packing Company was a part of this history as a fishing and fish-packing company with its headquarters on this site and canneries and processing plants scattered across much of Southeast Alaska. During the off season, Ward's Cove's fleet of commercial fishing vessels and tender boats were docked here for maintenance.

While the Lake Union waterfront has its history in maritime industries such as fishing, lumber, and shipyards, its future appears decidedly more residential. Understanding the value of its waterfront real estate, Ward's Cove ceased fishing and canning operations in the early 2000's and reinvented itself as a development company, converting its industrial wharves to upscale houseboats and pleasure craft moorage. This development begins to give a new and more cohesive sense of community to the immediate area.

Created concurrently with this redevelopment, directly across the street from the north end of the site there is a public pedestrian path and small "pocket park" green space stretching

along the waterfront immediately across Fairview. This green space includes a small beach with public pedestrian water access and a hand boat launch. About a half-block north of the site sits the Eastlake Pea Patch – a public park space that allows for individual garden plots tended to by green-thumbed residents. The pea patch abuts another small park immediately to the north which provides a public staircase leading uphill to Eastlake Ave. These newer public amenities soften the otherwise industrial nature of the Lake Union waterfront in the immediate area adjacent to the project site, and demonstrate the shift of the neighborhood towards a more residential complexion.

As we look at the site itself, there is a grade change through the lateral section of the property. Over the 85 feet between the west and east boundaries there is a vertical difference of approximately 16'. North to South the site is roughly level, dropping slightly from South to North. At the east boundary – the uphill side -- of the site is an alley easement which is designated 15' from the centerline. No physical alley currently exists here aside from a narrow driveway providing access to the back corner of the southern-most neighboring office building to the East.

Directly to the east sits a duplex of office buildings which

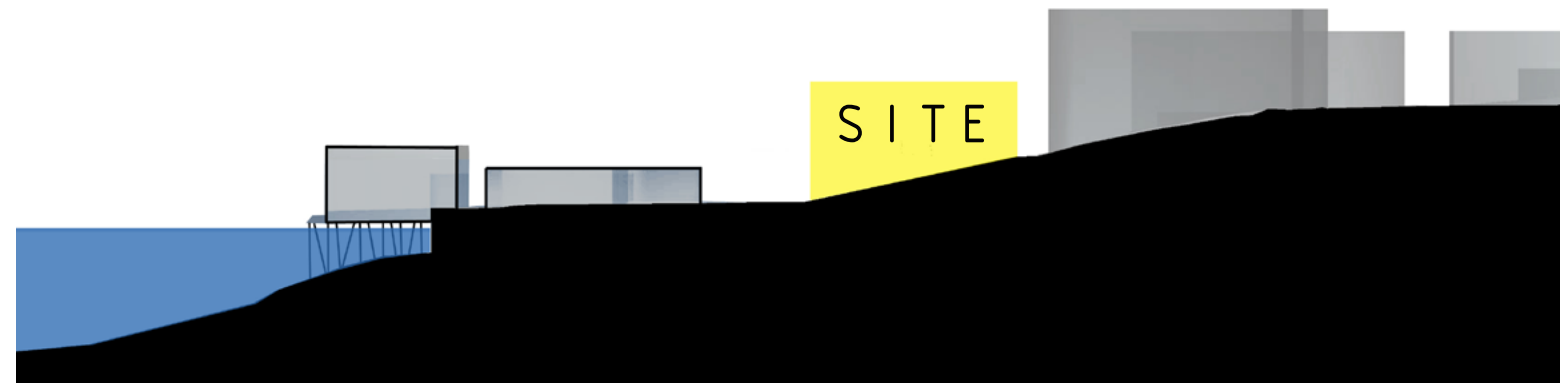

FIGURE 12: Rough site section demonstrating the 16' grade change through the site laterally from Fairview Ave East up to the alley. Buildings left of the site are Ward's Cove. Buildings to the right are 4 story office buildings which face onto Eastlake Ave.

face onto Eastlake Ave with their back side facing the site. These offices are four stories and are substantial concrete-framed buildings. Due to the significant grade change between Fairview and Eastlake Avenue, these offices loom large over the site. The ground floor of these office buildings at the Eastlake side of the building is two full stories off above the level of the alley. In other words, the front façade is 4 stories tall, but the back façade is 6 stories. Just north of these offices, adjacent to the north end of the site is a relatively new mixed use building which also fronts on Eastlake Ave and stretches north of the site for a full city block. This building consists of four wood-framed residential stories above a concrete base level containing retail and parking. The style is typically referred to locally as a "4-Over-1."

The immediate neighborhood is organized linearly alongside the spine of Eastlake Ave and is contained on all sides by the northward-tapering boundaries of the Lake Union shoreline and the hulking trestle of Interstate 5. This neighborhood shows definitive evidence of its humble and industrial recent past nearly everywhere you venture away from the largely redeveloped bustle of Eastlake Ave. Aside from the larger scale of much of this Eastlake corridor, the residential portion of the neighborhood is a mix of modest condo complexes, smaller single family residences,

and small-to-medium sized apartment buildings. Another element contributing to this finer-scale residential mix is the presence of several small floating home communities on the lake that are accessed via Fairview Ave East. These floating homes, by virtue of both their humble history and modern zoning restrictions, are also modest in scale and appearance.

Due to the low height of the shoreline development adjacent to the site, view opportunities out over lake union are significant, and will be especially so from a second or third story level. Views include the city skyline and space needle to the southwest, Lake Union and Gasworks Park to the immediate west, and partial views of the Olympic Mountains in the distance.

Fairview Ave north and the site are oriented about 30 degrees off-axis from a true north/south vector. This represents a shift in the city grid that begins at the intersection of Hamlin Ave east, immediately south of the project site. This localized grid shift encompasses only the immediate portion of the neighborhood from the south edge of the site north, forming a triangle bounded by Lake Union to the west, I-5 to the East, and East Hamlin Street to the south, which creates a dynamic relationship between the site, the lake shore, and the surrounding urban fabric.



FIGURE 13: Yellow lines highlight the axes of Fairview Ave East, East Hamlin Street, and Eastlake Ave to the south of the site and demonstrate the shift of the city grid at the southwest corner of the site.

DAYLIGHT AND ZONING

Daylight access to the site is good for much of the day and through most seasons. Due to the residential nature of the neighborhood and the low rise industrial/residential zoning of the waterfront, solar exposure to the south and west of the site is excellent. During the deep winter months, however, direct sunlight to the site is obscured for much of the day by the topography to the east and to a lesser extent, to the south. This lack of direct sunlight to the site during December and January should be minimized by the fact that the overwhelmingly prevailing sky condition during these months is diffuse overcast.

Current zoning of the project site is “LR2-RC” - or Low-rise 2, Residential/Commercial. This zoning allows for mixed-use buildings, with a maximum envelope height of 35’ for buildings with pitched roofs. As the site is set into the hillside with large buildings looming overhead to the east, I will propose an extension of this height limit to accommodate the need for tall spaces within the program of the building. This additional height seems justified given the context of the surrounding buildings and topography and the fact that additional height will not adversely affect the view opportunities of adjacent buildings.

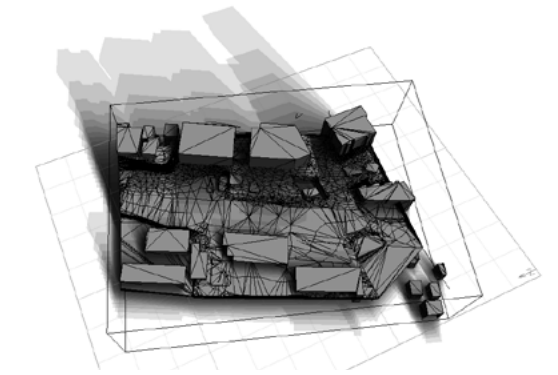

FIGURE 14: Solar shadow range study for December 21 shows decent daylight penetration into site other than in the morning hours. Summer solar access is uninterrupted.

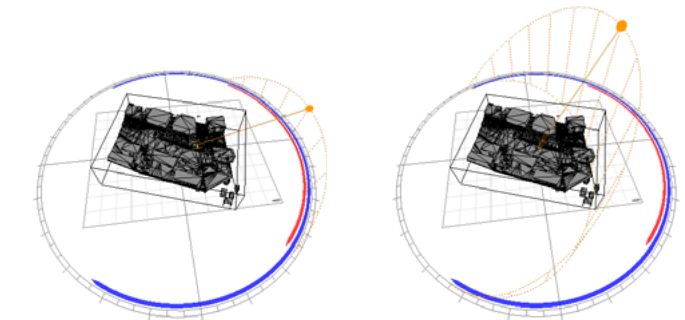

FIGURE 15: Solar path studies for December 21 (left) and June 21 (right)

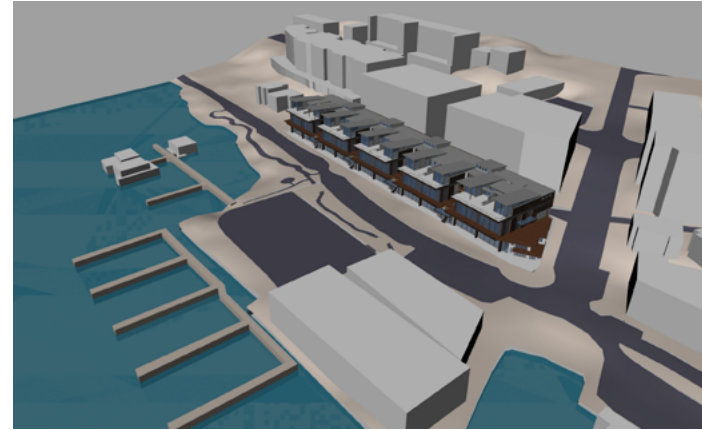
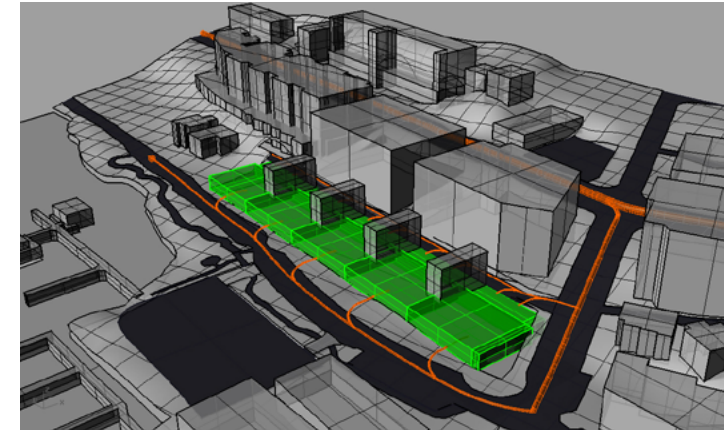

FIGURE 16: Simplified site perspective and final massing, looking from the southwest.

MASSING AND CIRCULATION

The building consists of five main units arrayed along the length of the site, each with three levels. Access to all levels is provided via external vertical and horizontal circulation. The building is envisioned as a cohesive working community suitable to be marketed to a wide array of tenants related, perhaps loosely, to different aspects of the building trades and professions. However, the building is intended to be flexible enough on all levels to achieve longevity through adaptation and reinvention as needed throughout its life.

Circulation and access to each unit is from the exterior, as each space is envisioned operating independently from the others. This circulation pattern is driven by the topography of the site and the massing of the building's spaces. Because the building is accessed from two sides at different levels it was important to maintain porosity through the building and site in the east west direction, thus providing access to every unit from either direction. Vertical circulation is located in gaps between each of the five main units of the building, maintaining security while allowing for this porosity. These exterior circulation spaces have the added benefit of allowing for informal meeting spaces around and between the



Vehicle Access - 1st and 2nd levels, front and back

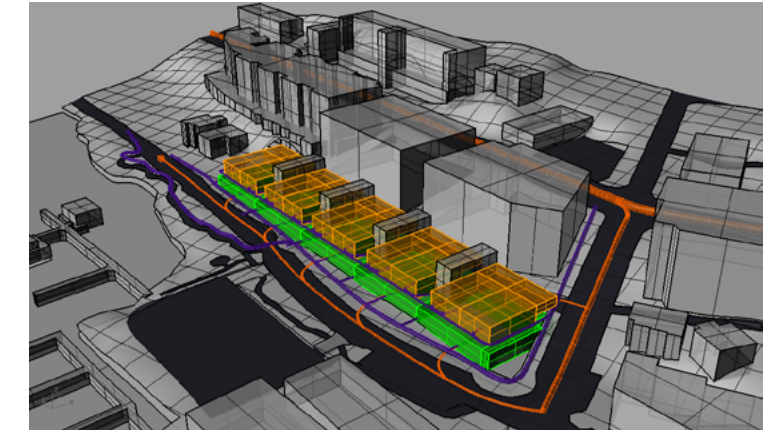

Public/open circulation.

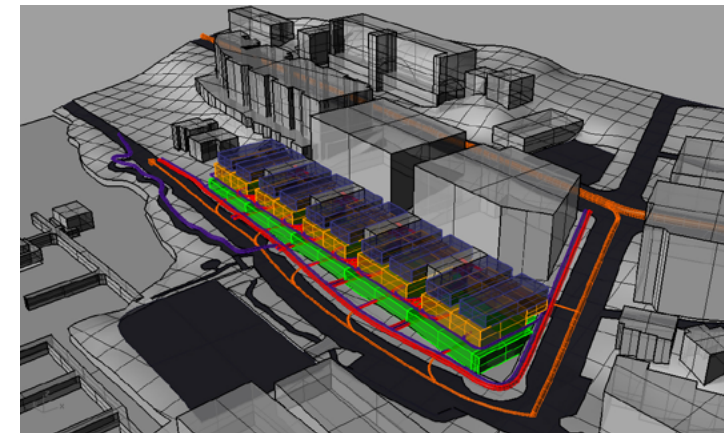

Private/Tenant circulation

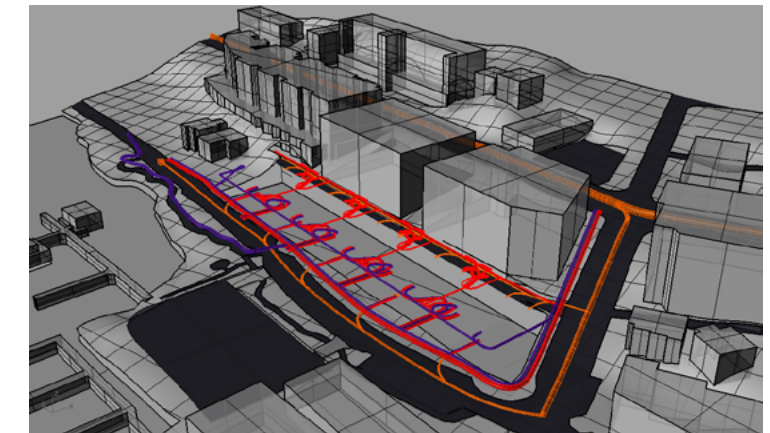

All circulation

FIGURE 17: Site access and circulation. Vehicular access is available to all units on the first and 2nd levels via either Fairview Ave East (foreground) or the alley. Alley access is at the 2nd level. Both vertical and horizontal circulation occurs between and around the buildings, on the exterior. Units of the building function independently of one another, but the scheme provides many opportunities for interaction through informal exterior meeting spaces within the circulation paths.

commercial units. These informal meeting spaces are intended to enhance the community cohesiveness within the building.

Each of the three levels has a different character and a different intended purpose. The ground floor is accessed from Fairview Avenue and consists of large, open, double height, commercial/light industrial spaces that measure approximately 80' wide and are largely uninterrupted by structure. Large glass door systems allow vehicle access from Fairview and provide adequate daylight deep into the floor. This level is intended for varying degrees of industrial or workshop activity – ideal for a large cabinet shop or small boat builder, or perhaps a door shop or custom woodworker.

The second level sits at approximately the level of the alley at the east side of the site. Vehicle access is provided here via a parking area off the alley which also serves as a light-duty loading dock, suitable for vehicle up to the size of a medium panel van. The second level is intended to be completely flexible. The second level consists of paired double-height spaces that are approximately 32' wide. The double height units here are open on the west side, and split by a loft which carries over the loading dock/parking space to the east. These fully flexible spaces are

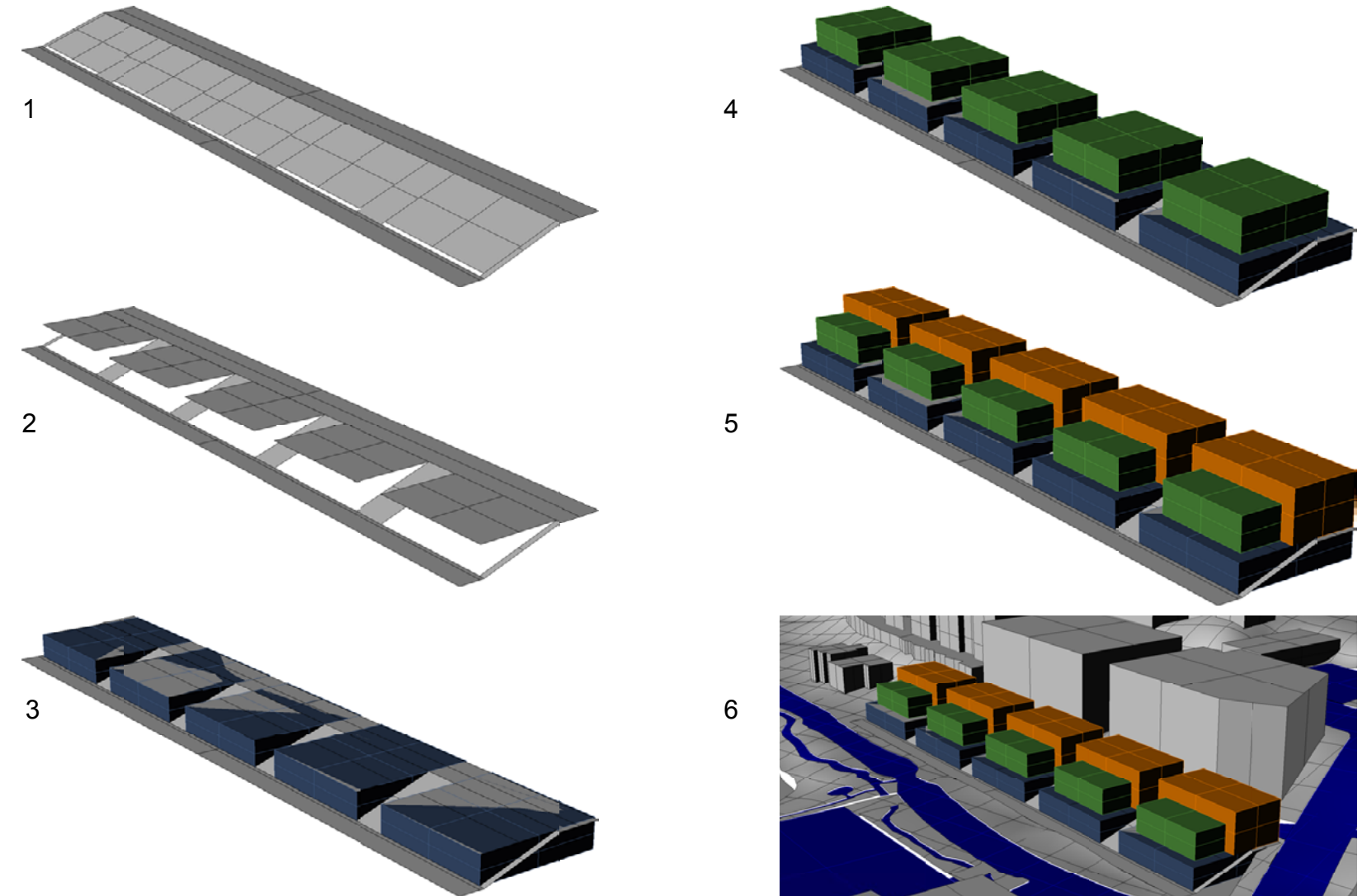

FIGURE 18: Massing study sequence. Massing was conceived to facilitate the circulation scheme. The first level sets into the topography, matching the first level roughly with the grade change and allowing ground level access to the second level at the back of the site. The result is a building that is fully oriented towards the water and views, but that is still functionally multi-sided and fully flexible. Flexibility is of paramount importance to the longevity of the building, and the massing reflects this.

accessible from both the alley and Fairview avenue via external circulation. The spaces are intended to be suitable as office space, a design or art studio space, or even a smaller scale light-industrial/commercial space. Tenants who might find these spaces fitting would range from a general contractor's office or design/build firm to a small-scale custom fabricator or art studio.

The third level is intended to be largely residential. These, too, though, are flexible units designed to be adapted to a wide variety of uses and lifestyles. The three main units consist in the center of the building consist of paired loft-style residential units at this third floor level. These units are approximately 1500 square feet each, all on one level. They feature large configurable open main spaces with a pair of bedrooms each. Each residential unit has a large, private outdoor space intended to serve as an "urban yard" for the tenant, looking out over Lake Union and the territorial views.

The residential units at the north and south units of the building are larger, more upscale residences. Each of these is a large single unit approaching 2500 square feet, with large master bedroom suites, and three additional bedrooms each. They also feature a large, private outdoor entertainment space.

All the residential units are created as though a penthouse atop the commercial portion of the building. The intention is to provide large, comfortable living spaces on a single floor with private outdoor space – features not common in a modest urban setting. Special attention has been given to orienting all the residences toward the western views over Lake Union.

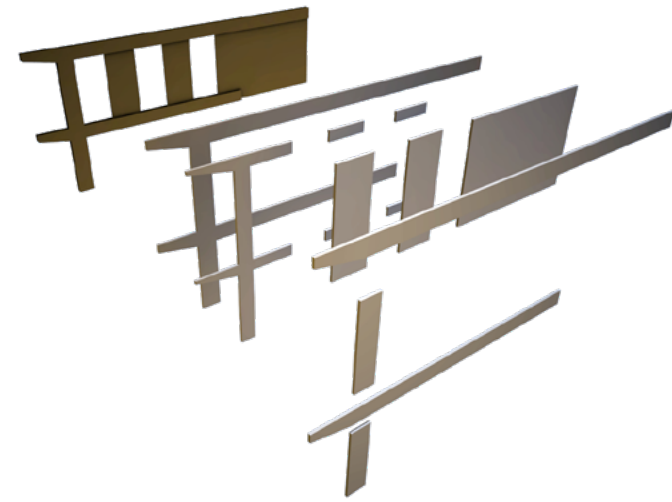

FIGURE 19: Truss assembly. The primary structure is provided by built-up trusses of LSL panels which sits on load bearing walls at the back edge of the site and span the width of the building. This configuration retains programmatic flexibility on all levels, while creating a completely unobstructed space at the ground floor.

STRUCTURAL SYSTEM

The organization of the building is driven partially by site and program, but it is also driven largely by the structural system. The main structural system of the building consists of a series of large planar trusses that carry through the second level, creating open uninterrupted space on the ground floor and a platform for the third floor. The trusses are built of large LSL panels sandwiched between paired top and bottom chords, also of LSL. The trusses sit upon a concrete box that forms the retaining wall at the length of the east side of the site. This box also forms the base for the parking area at the second level. The trusses span 48' of the ground floor and rest on doubled LSL columns at the front façade of the building. These columns form planar wall fragments and help provide lateral shear for the structure.

Each of the five main sections of the building consist of three trusses on 32' centers. Each triad of trusses is spaced 24' from the next, creating the circulation space between the sections. The center truss of each triplet divides the second floor into two distinct units. The trusses are not solid though, being composed of 8' wide panels, and thus they allow this second story to operate as one unit or two depending upon how the truss is used as a

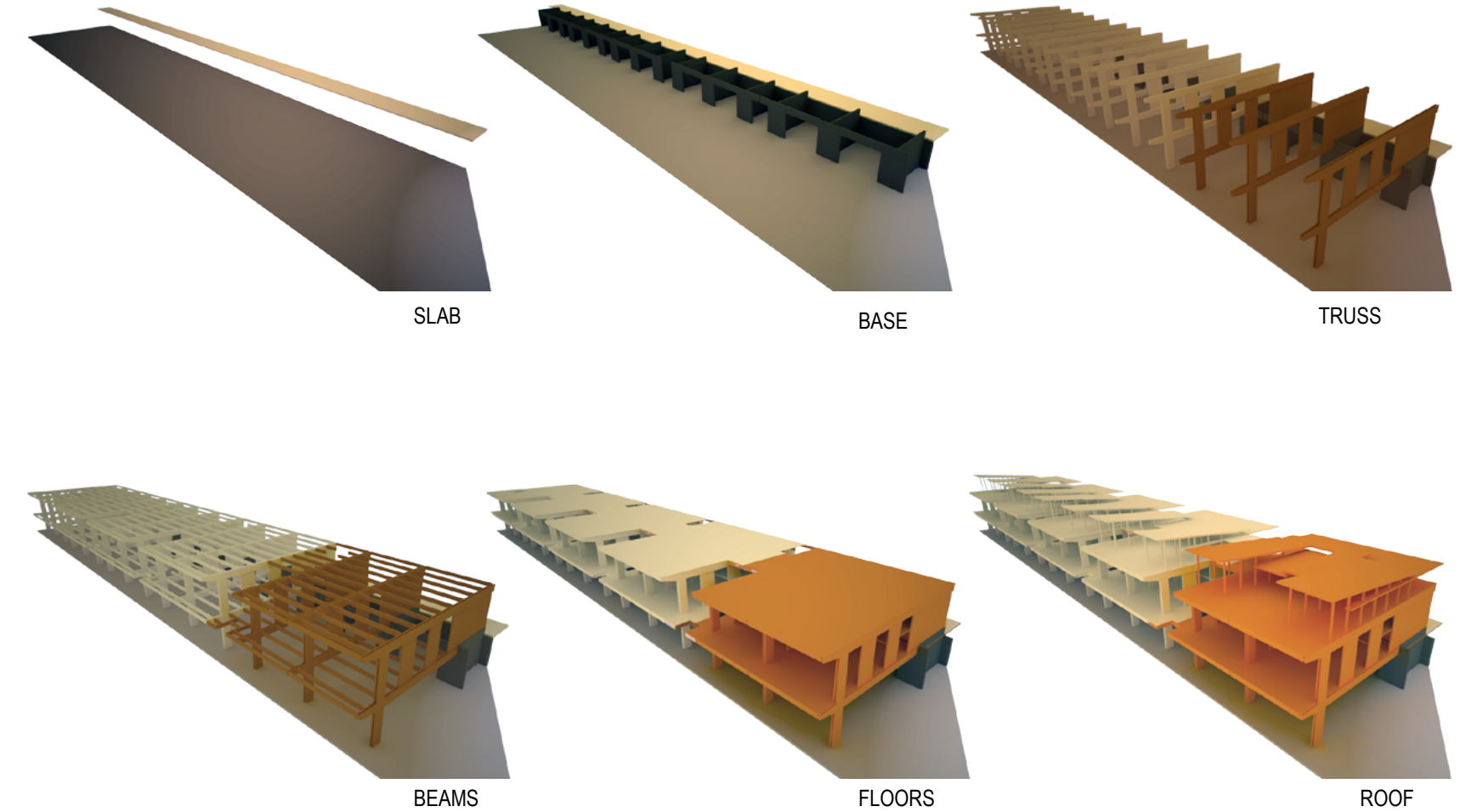

FIGURE 20: Structural assembly. The structure is driven by the massing, circulation, and the desire to create open flexible spaces, especially on the first floor. The system begins with a series of planar trusses that set into a base of shear walls. Secondary beams then tie these trusses into boxes, which are clad in cross-laminated LSL structural floor plates. Finally, the residential structure and roofs are mounted on the plinth created by the lower two floors.

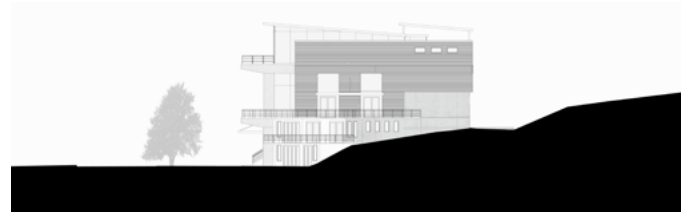

FIGURE 21: South Elevation



FIGURE 22: Section

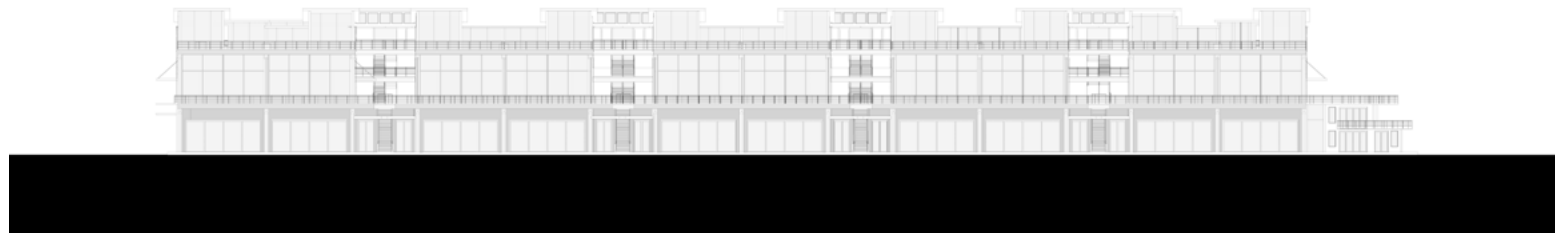
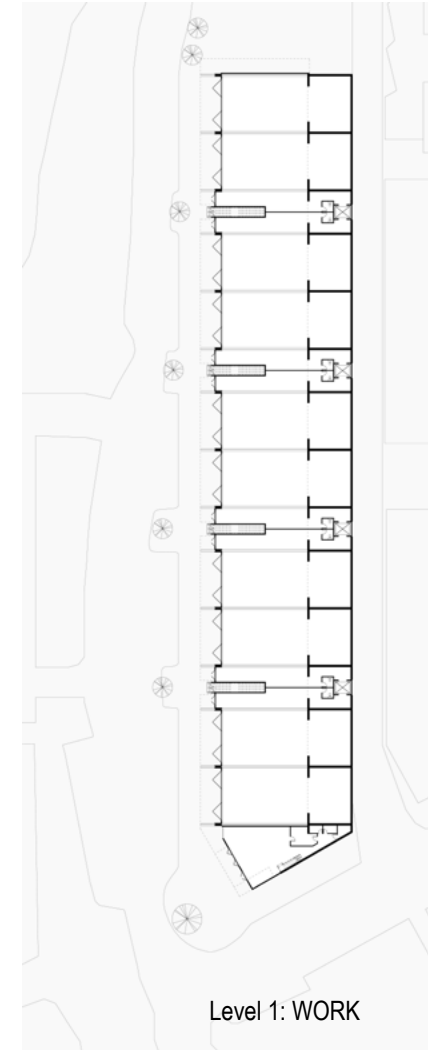
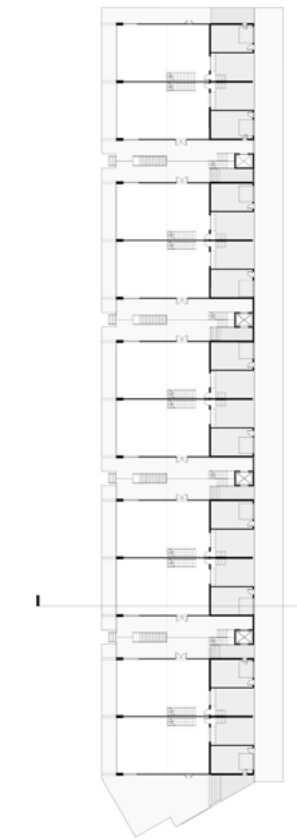

FIGURE 23: West Elevation



Level 1: WORK



Level 2: FLEX



Level 2.5: LOFT



Level 3: LIVE

FIGURE 24: Plans

partition.

A secondary structure of LSL beams spans between the top and bottom chords of the trusses. These beams are on eight foot centers. This beam and truss system is then completed with 16' by 8' cross laminated LSL panels. These panels are 6" thick and consist of 4 layers of 1 1/2" thick LSL strips oriented in opposing directions. The panels fit together at their edges in a ship-lap fashion and are then connected with steel connections and suitable lags. This system would be prefabricated, and each floor slab, beam, and truss would be nearly identical, streamlining the assembly process. Because of the nature of the trusses of the primary structure, the simplicity of the beam and flooring system, and the structural independence of the building sections, this building could easily and economically be built in phases, as well.

At the residential level, the structure consists of partial post-and-beam style construction utilizing PSL columns on a 16' by 8' grid and LSL beams supporting a roof of SIPs. The east portion of the residential units will be supported by load-bearing shear wall assemblies in place of posts and beams. Interior partition walls will be standard stud walls where required in the residential portion of the building.

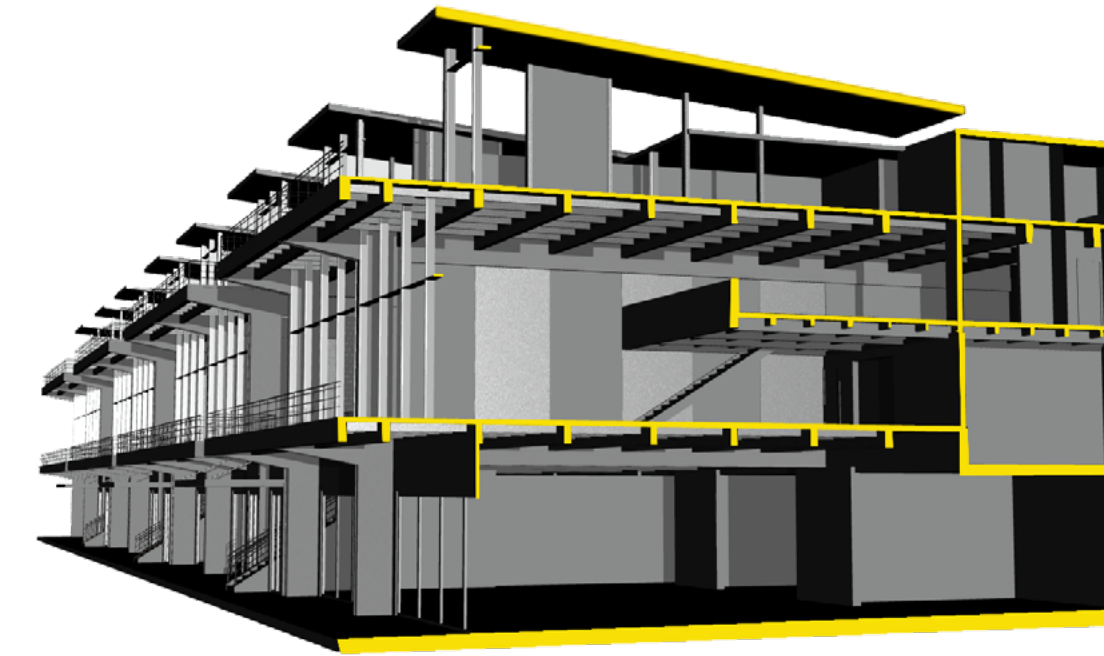

FIGURE 25: Section Perspective showing structure and interior stacking



FIGURE 26: Interior rendering of 2nd Level space, looking west from under loft floor. Engineered wood systems serve dual purpose as finished interior surfaces, exposing the nature of the structural system. The building is insulated on the exterior of the structure below the cladding system. The raw interior expresses the intended programmatic uses of the interior, but allows for refinement and flexibility for any future changes in the program of the building.



FIGURE 27: Rendering of West Elevation showing exterior circulation gaps and structural approach.

The exterior of the building will be simply clad using a typical wood rainscreen system. This rainscreen would employ both horizontal wood planks and a panelized siding system. In the rendering shown here, portions of the structural frame have been left exposed in order that the frame might be more clearly expressed visually in the presentation. It is understood that while engineered composite lumber could be treated to resist the elements, it would not be practical in practice to leave the frame exposed. The frame will be insulated and clad in a suitable panelized rainscreen system.



FIGURE 28: Rendering from 3rd Level exterior deck space of northern-most residential unit looking southwest. Residences are oriented for visual privacy from one another, while retaining expansive exterior living space and excellent access to daylight and views through use of tall west facing glass.

CONCLUSIONS

This building strives to marry past and present in multiple ways. The mixed use program of the building, with graduating levels of industrial scale as one moves vertically, works to retain the former industrial and commercial character of the Lake Union waterfront while acknowledging the changing residential nature of the neighborhood. The wood systems are exposed throughout the building, making it clear that this is a wood building and tying the building in character with the tradition of building with wood that is a comfortable part of the history of the Pacific Northwest. At the same time, the exposed structural systems make very clear that this is not a conventional wood building composed of trees sawn into rectangular sections. The exposed systems demonstrate in a tactile and visual way that there is a new way of thinking of wood as a structural material whereby it can be reconstituted into more structurally uniform and predictable forms. The recycled nature of the wood systems will convey the idea that the long local history of cutting trees for structural members is fading in favor of moving towards a more sustainable way of thinking about wood. The changing aesthetic and tactile nature of the neighborhood is reflected in the new aesthetic and tactile qualities of the exposed engineered composite wood structural system.



FIGURE 29: Exterior Rendering, from Hamlin Ave looking west at south elevation of building. Topography of site creates access from Hamlin to both the 2nd Level exterior circulation platform as well as to the intermediate exterior level of the corner cafe. Pedestrian access to both levels of the building from both directions adhere to the goals of the building as a cohesive community of tenants with casual connection to the neighborhood and public at large.

The days of viewing wood as a renewable resource that is more easily replaced than recycled are fading. We have the technology to make the reuse and recycling of wood fiber as accepted as recycling of metal is today. What's more, we have the potential to create superior engineered wood products while expending less energy and with a significantly smaller carbon footprint. We can allow our forests to grow longer and live to their full carbon sequestering potential before harvest, simultaneously allowing them to provide us with larger, more structurally capable, and aesthetically attractive wood when they are finally harvested. The economic incentive may not yet fully exist to drive our wood production entities to these conclusions, but those economics are changing. As we understand more about climate change and the adverse effects of excess carbon dioxide in our atmosphere, the incentive structure in the building industry will almost certainly move towards rewarding smaller carbon footprints. Even as wood and engineered wood products are the most environmentally sustainable materials for building available today, there is room for significant optimization. Projects that demonstrate the significant structural, environmental, and architectural advantages that new structural composite systems might provide can only add incentive to move us in the right direction.



FIGURE 30: Exterior Rendering, from intersection of Hamlin and Fairview Ave E, looking northeast. The building strives to marry the history of the industrial neighborhood with its decidedly more upscale residential future. The exposed engineered wood systems likewise hint at a long history of building with wood, while clearly showing the modern advances in engineered wood.