

Where is the Person in Personalized Medicine?
The Missing Expert in Adaptive Neurotechnology

Gabrielle Strandquist

A dissertation
submitted in partial fulfillment of the
requirements for the degree of

Doctor of Philosophy

University of Washington
2024

Reading Committee:
Jeffrey Herron, Co-Chair
Rajesh Rao, Co-Chair
Kurtis Heimerl

Program Authorized to Offer Degree:
Computer Science and Engineering

© Copyright 2024

Gabrielle Strandquist

University of Washington

Abstract

Where is the Person in Personalized Medicine?
The Missing Expert in Adaptive Neurotechnology

Gabrielle Strandquist

Co-chairs of the Supervisory Committee:

Jeffrey Herron
Neurological Surgery

Rajesh Rao
Computer Science and Engineering

Neurological disorders are the leading cause of disability-adjusted life years and the second leading cause of death worldwide, with most having no cure. Ensuring people with neurological disorders have access to effective treatment and care is crucial. This dissertation presents a case study on the delivery and effectiveness of treatment for people with Parkinson's disease (PD), a progressive neurodegenerative disorder that negatively impacts mobility, sleep, vision, speech, psychological well-being, and more. Deep Brain Stimulation (DBS) is a neurosurgical treatment for PD that delivers electrical stimulation to deep brain structures. Adaptive DBS (aDBS) represents the next generation of this technology, dynamically adjusting stimulation parameters in real-time to treat symptoms more precisely. To deliver aDBS in home settings, infrastructure and remote symptom monitoring are needed.

We conducted a two-year study building and deploying a prototype platform ecosystem to the home of a person receiving DBS therapy for PD. This novel system used in-home video cameras, wearable sensors, and chronic neural signal recordings to remotely evaluate treatment efficacy of aDBS during controlled tasks and naturalistic behavior. The open-source platform ecosystem supports remote updates to aDBS algorithms and can scale to many users. I next developed kinematic metrics of movement quality that significantly correlate

with clinical symptom ratings from neurologists using data collected from our platform.

Motivated by reviewer feedback and strategies in person-centered design, I explored the participant's experience through reflexive thematic analysis of an exit interview and non-numerical data collected throughout the study. This analysis revealed that actively viewing the participant as the Expert in living with PD, in living with DBS, and in interacting with our systems will improve the participant's experience and research outcomes. The analysis also provides important context to our collected data and kinematic metrics. I formulated key strategies for actively viewing study participants as experts as a guide for student researchers.

Finally, I propose Participatory Action Research (PAR) as a strategy to guide researchers who want to collaborate with research participants in solving neurological problems. PAR is based on tenets for how to collaboratively conduct research, offering a flexible framework that engages with a community and centers the needs of the people that solutions are intended for. I call on the scientists, engineers, clinicians, and other authorities researching treatments for neurological disorders to stop excluding participants from the research process, and we outline ways that PAR can assist with the unique challenges of developing more effective treatments for neurological disorders.

Acknowledgements

First and most especially, my sincere and humble thanks to the participant that enrolled in our study: none of this work would exist without your enthusiasm for collaborating in research, your persistence in re-repeating the many experiments that went awry, and your willingness to having a prototype platform including webcams installed in your home. I gratefully acknowledge your technical insights as we first scoped this project out, and your frequent troubleshooting support throughout the study. It was a privilege to learn from the many ways that you innovated along the way – may our work be a help to many.

Thank you to my advisors: To Professor Rajesh Rao, thank you for your consistent support throughout this entire 5-year journey. To Professor Jeffrey Herron, thank you for your advice on writing my first paper with an army of opinionated co-authors, for showing me how to build a PC from parts, and for introducing me to that friend of progress and enemy of perfectionism, the MVP.

To the brilliant students of the Neural Systems and GRID labs: thank you for your consistent open-mindedness and insightful feedback. To my fellow trainees from the Weill Neurohub Optimal aDBS project: your tenacity in the trenches showed me my love of working in teams, and your enthusiasm for science kept me fighting the good fight. Thank you Dr. Tomek Frączek for bringing Alien Man to life, and for being the best partner-in-pilot-deployment I could have hoped for. I gratefully acknowledge Dr. Zöe Steine-Hanson, Jazlin Taylor, and Dr. Courtne Paschall for their insightful contributions in the thematic analysis of this work. Thank you to Professor Kurtis Heimerl and Dr. Esther Jang for creating the excellent Computing for Social Good class that challenged my notions of what Computer Science is and offered me new ways to explore what it can be. Thank you Esther for introducing me to the worlds of qualitative methodology, action research, and how to build things *with* community rather than *for* them. Thank you Professor Caryl Feldacker for the candid discussions on doing effective research in and around the world.

I gratefully acknowledge the wonderful people who volunteered their time to consult with me on the 2nd half of this work: Thank you Professor Tim Brown for your thoughtful feedback on my study design and for offering that rarest of ivory-tower unicorns: encouragement. Thank you Dr. Elin Björling for sharing your human-centered design expertise and for asking clarifying questions to hone my approach. Thank you Dr. Ashley Walton for your insights on design thinking and when we should begin engaging with participants. A special thanks and appreciation to Dr. Lucia Feldmann for your beautiful and much-needed paper on engaging with participants in DBS research.

My sincere gratitude to the kind humans who supported me during the early period of my PhD: To Professor Chet Moritz, thank you for genuinely caring about your students and actively following up on my well-being and safety. To Dr. Steve Peterson, thank you for patiently mentoring me through so many steep learning curves. To Dr. Alice Schwarze, thank you for our weekly chats during the months of remote-only interactions. To Dr. Satpreet Singh, my everlasting gratitude for your kind assistance in helping me secure lodging that one time at NeurIPS, and for sharing your beautiful perspective that when things are most difficult, "the warriors come out".

To my first friend in Seattle and fellow kitchen-to-tech reinventor Amanda Anderson (1990 - 2022): thank you for adopting me from our very first meeting, for introducing me to the phenomenal culture of Seattle's drag, and for insisting on authenticity in your relationships. Rest in peace my beautiful friend. Thank you to Best for standing by me as I pivoted from pastry chef to computer scientist, for your countless hours helping me externally process, and for gently helping me get back up after each setback. Thank you to Squish for being my family these 20+ years: you are stuck with me forever and ever. To my work-wife Courtnie, thank you for mentoring me through calculus at 3am, for Disney-fueled all-nighters, for your generous brilliance in our ideating sessions, and for watering the seeds of my dreams. Thank you to my cousin Michael Mills for being my grounding port in many a storm, for the karaoke and smoothies, and for loving me without judgement. Thank you Zöe for 5 years of book club and for commiserating and cheer-leading with and for each other these wild 5 years. Thank you Ben Kushigian for our chats on the beauty of software and poker, for making me laugh till I cry, and for encouraging me to be angry, brave, and true to myself. To Micah Powell, thank you for teaching me pop culture references, for telling me I can do it on the many occasions I wanted to (dramatically) throw in the towel, and for unconditionally accepting me in every state.

My gratitude to the National Science Foundation for granting me a Graduate Research Fellowship which facilitated my ability to freely pursue my own ideas.

To those who told me my ideas had no value: thank you providing me with the unmistakable indicator that I was onto something good.

"Let us step out into the night and pursue that flighty temptress, adventure."

–Albus Dumbledore

Harry Potter and the Half-Blood Prince

DEDICATION

To Christian Mason, who showed me that I can do anything,
and to Professor Gabriel Robins, who flung open the doors to everything and everywhere.

Contents

1	Introduction	15
1.1	Characterization and Treatments for PD	17
1.2	Translating aDBS Therapy to the Home	18
1.2.1	Platforms for Neurotechnology Translation	19
1.2.2	Remote Symptom Monitoring	20
1.3	At Home: The Other Side of Neurotechnology Translation and Effectiveness	22
1.4	The Weill Neurohub Automated Optimization of aDBS for PD Project	23
1.4.1	Project Organization	24
1.4.2	Positionality	24
1.4.3	Project Communication	25
1.4.4	Home Setup	25
1.4.5	Set up for self-guided experiments at home	26
1.4.6	On Terminology	26
1.5	Dissertation Roadmap	26
2	Bringing the Clinic Home: An At-Home Multi-Modal Data Collection Ecosystem to Support Adaptive Deep Brain Stimulation	30
2.1	Introduction	30
2.2	Protocol	34
2.2.1	At-Home System Components	34
2.2.2	In-home configuration	40

2.2.3	Data collection	42
2.2.4	System Characterization	44
2.2.5	Post-hoc Data Pre-Processing and Alignment	45
2.3	Results	47
2.4	Discussion	51
2.5	Acknowledgements	54
2.6	Disclosures	55
3	In-Home Video and IMU Kinematics of Self Guided Tasks	56
3.1	Introduction	56
3.2	Methods	59
3.2.1	Summit RC+S implantation and neural data streaming	59
3.2.2	Inertial Sensing	59
3.2.3	Video Collection System	60
3.2.4	Security and Network Design	60
3.2.5	Preliminary Data Collection and Controlled Experiments	61
3.2.6	Gesture-based Data Alignment	62
3.2.7	Apple Watch Angular Velocity for Symptom Assessment	62
3.2.8	Video-derived Pose for Symptom Assessment	63
3.2.9	Clinical Ratings and Correlation Analysis	63
3.3	Results	64
3.3.1	Gesture-based data alignment	64
3.3.2	Symptom Assessments	64
3.4	Discussion	66
4	The Missing Expert in Neurotechnology: Context and Expertise from the Research Participant	70
4.1	Introduction	70
4.2	Background	73
4.2.1	Spurned Ologies in Clinical Research	73

4.2.2	Implications of Paradigm Divisions for Neurotechnology Translation	78
4.2.3	Participant Engagement in Clinical Research	80
4.2.4	Who Defines Effectiveness?	81
4.3	Methodology	82
4.3.1	Study Design	82
4.3.2	Researcher Assumptions	83
4.3.3	Data Collection	83
4.3.4	Data Analysis	84
4.3.5	Field Notes Analysis	86
4.4	Results	88
4.4.1	Theme 1: Problem-solving at home to simplify everyday life	88
4.4.2	Theme 2: The Mismatch Effect: The Costs of Structuring an at-home aDBS for PD study as a traditional clinical study	93
4.4.3	Theme 3: The effects of When, Where and How on <i>What</i> gets communicated	103
4.4.4	Theme 4: Who is the Person in Personalized Medicine?	106
4.5	Discussion	109
4.5.1	On Complexity: It Gets Worse Before It Gets Better	109
4.5.2	Time for a Re-Match: Structuring At-Home aDBS Research	111
4.5.3	Considering Communication	117
4.5.4	The Unseen Expert of Neurotechnology	118
4.6	Conclusions	121
4.7	Dear Quantitatively-Trained Students Researchers: Recommendations for Translational Neu- rotechnology Research	123
4.7.1	Personal Research Background	124
4.7.2	Student Recommendations for Translational Neurotechnology Research	125
5	Participatory Action Research for Responsibly Engineering Neurotechnology	130
5.1	Introduction	130
5.2	Tenets and Tensions of PAR	132

5.3	Trustworthiness for Generalizability	135
5.4	A Worked Example of PAR for Clinical Neuroscience Research	137
5.5	Recommendations for PAR in Neurotechnology Translation	138
5.5.1	Establish Community Relationships	139
5.5.2	Defining Roles	139
5.5.3	On Transparency	139
5.5.4	On Communication	140
5.5.5	Collaborative Planning and Design	140
5.5.6	Research Implementation and Data Collection	140
5.5.7	Context	140
5.5.8	Sharing Results	141
5.5.9	Continuous Integration for Feedback	141
5.6	Conclusion	141
6	Conclusion	142
A	Appendix	172
A.1	Review-Cycle Questions from Anonymous Reviewers	172
A.2	Experiment Protocol	172
A.3	Supplementary Method	175
A.4	Exit Interview Questions	177
A.5	Exit Interview Code Book	178

List of Figures

1.1	Home Office Schematic with Camera System Placement	29
2.1	Data Flow of Platform Ecosystem	32
2.2	Video recording components	39
2.3	Gesture-based data alignment	46
2.4	Data Availability	48
3.1	Prototype aDBS Optimization Framework	57
3.2	Experimental Tasks During Data Collection	61
3.3	Pose and IMU Data Analyses	65
3.4	Pose and IMU Analyses Compared with UPDRS Scores	69
4.1	Clinical Neuroscience Citations in PubMed	71
4.2	Two Years of G-Chat Activity	86
4.3	Participant-Created Guide for Conducting Self-Guided Experiments	92
4.4	Participant-designed VPN Wireframe	98
4.5	Topics of Conversation in G-Chat	102
A.1	Video Frame Lag Analysis	176

List of Tables

2.1	Longitudinal overview of collected data	50
4.1	Themes from Reflexive Thematic Analysis	89
A.1	First Cycle Codebook	178

Chapter 1

Introduction

Neurological disorders are the leading cause of disability-adjusted life years (DALYs) and the second leading cause of death worldwide, with most having no cure [1]. The World Health Organization (WHO) calculates total DALYs for a disorder or disease as the sum of years lived with a disability, plus the years of life lost due to premature death. Parkinson's disease (PD) is a progressive neurodegenerative disorder affecting approximately 8.5 million people globally, and disability and death from PD are increasing faster than any other neurological disorder [2]. An estimate from 2019 found that PD caused 5.8 million disability-adjusted life years. PD symptoms negatively impact many aspects of life, including mobility, sleep, vision, speech, and psychological well-being [3; 4]. Having such a large range of symptoms presents difficulty for determining first what symptoms we should treat, and second in determining how to treat them. Treating one symptom can cause others to newly appear or else to worsen [5].

Difficulties from symptom inter-dependency are exacerbated by several issues surrounding equity. First, disabilities from neurological conditions affect certain population groups more than others, including women, people living in poverty, and people living in rural areas [6]. Second, inequity is rife in clinical neuroscience research practices. One source of inequity is an extreme lack of diverse data, where research participants are disproportionately from well-educated Western populations [7; 8; 9; 10]. This is exacerbated by insufficient disclosures about participant demographics in published research, which prohibits group comparisons from being made [11]. This is problematic, because demographics such as sex, race, socioeconomic status and ethnicity affect neural structures and functions and their related behaviors, in direct and indirect ways

[12; 13; 14; 15].

A second source of inequity is lack of diversity in the researchers themselves. This can be difficult to spot amongst ourselves, but research that is conducted by a homogeneous demographic of people biases our scientific assumptions and influences the research questions that we ask and the agendas that we set [12]. For example, MRI technology utilizes head coils which restricts big or afro-textured hair, and people with sew-in hair extensions may have metal components keeping them from entering an MRI machine [16]. Similarly, electroencephalography (EEG) electrodes which are an affordable brain sensing and imaging tool typically do not accommodate textured hair. In both these examples, using technologies on people they were not designed for can yield poor quality data that is discarded in later analyses, or else prevent the data from being collected altogether. This is just one way that designs that are not built for diverse populations contribute to the lack of diversity in existing data [17; 18].

All of these factors severely impede our ability to properly replicate or generalize scientific results, which are two principal drivers for how modern-day research is conducted. This in turn causes our strategies for treatments, interventions, and developed technologies to be inherently flawed [7; 19].

In this dissertation, I present a two-year case study investigating ways to identify and treat certain symptoms of PD through the advent of neurosurgical therapies and integrated systems for delivering treatment. I first developed a novel system for remotely delivering and maintaining neurotechnology therapy to people's homes, in collaboration with researchers from the University of Washington, the University of California, San Francisco, and the University of California, Berkeley. I developed methods to assess movement quality as a proxy for determining treatment efficacy outside the observation of a clinician. I then contextualized my prior work by analyzing the experience of a person with PD who participated in the two-year case study. This analysis revealed key strategies to counter some of the inequity in neuroscience research practices, which I formulated into recommendations for future students researching this space.

The remainder of this chapter is structured as follows. In section 1.1, I first characterize PD and describe current methods for treatment. In section 1.2 I describe the importance of making treatment available to people at home, and discuss strategies for remotely supporting treatment delivery. In section 1.3, I overview ways that people are involved in their own care, including interacting with neurotechnology therapies, and participating in collaborative research that engages with community groups. In section 1.4, I describe the

longitudinal study that led to this case report. I conclude in section 1.5 by articulating my research aims and their results that I developed for this dissertation.

1.1 Characterization and Treatments for PD

PD was first described as “Shaking palsy” over 200 years ago by James Parkinson. In fact, PD is characterized by many motor and non-motor symptoms, which cause loss of muscle control and contribute to disabilities [3; 4]. The principal motor symptoms of PD occur when neurons in the substantia nigra start to die due to unknown causes. This decreases dopamine production, which in turn upsets the balance of neural circuitry in the basal ganglia. These circuits help to control and coordinate our bodies by inhibiting unwanted movements, and initiating desired movements [20]. Difficulty initiating movement is a cardinal symptom of PD called bradykinesia, which is characterized by a slowing or shrinking of movement [21]. Dyskinesia appears as something of the reverse to bradykinesia, where movement starts and persists without the person intending to [22]. Remarkably, our current understanding of basal ganglia pathophysiology does not provide an adequate explanation for the two other cardinal features of PD, namely, movement rigidity and tremor [20]. Tremor is a rhythmic involuntary oscillation with frequency range of 4-12 Hz typically seen in the extremities [20; 5]. Symptoms of PD impact many major systems of the body beyond the motor system, including depression, anxiety, sleep disorders, fatigue, pain, skin issues, problems with speech and vision, erectile dysfunction, olfactory problems and many others [3; 4]. These symptoms progress over time, severely impacting quality of life.

Surgical treatments such as removing or lesioning portions of brain tissue have existed for decades, however research in this space came nearly to a standstill at the advent of the drug Levodopa-Carbidopa which greatly helped to control many symptoms of PD. This promised a less invasive treatment option than neurosurgical treatments, particularly treatments involving irreversible removal of brain tissue. Unfortunately, Levodopa-Carbidopa was found to be primarily effective only during the early stages of PD. This led to renewed research activity in neurosurgical treatments, including Deep Brain Stimulation (DBS) which does not involve removing or damaging tissue [23]. DBS involves chronic implantation of electrodes into the subthalamic nucleus (STN) or the pars interna of the Globus Pallidus (GPi) for delivery of electrical stimulation. A pulse generator is also implanted in the chest which controls stimulation parameters, such as

the frequency, amplitude, or pulse width of the electrical current [5; 24]. The US Food and Drug Administration (FDA) approved DBS treatment for essential tremor in 1997, DBS of the STN for PD in 2002, and DBS of the GPi for PD and dystonia in 2003. These uses were similarly approved in Europe, who additionally approved DBS for epilepsy in 2010. DBS is also being investigated for its ability to treat chronic pain, Alzheimer’s disease, and psychiatric disorders including treatment-resistant depression and Tourette syndrome [25]. Despite its success in treating several neurological conditions, DBS is hindered from being delivered at scale by a time-consuming process of tuning the stimulation parameters. This process is currently performed manually by clinicians for each individual person.

Adaptive DBS (aDBS) is the next generation advancement of conventional DBS (cDBS), where parameters are adjusted in real time based on disease- or symptom-related biomarkers [26; 27]. aDBS was first introduced in 2006, promising a more precise and adjustable therapy that additionally can mitigate undesirable side-effects that occur when fixed stimulation parameters are unsuitably matched to the changing needs of the body [28; 29; 30; 31; 32]. Studies have shown beta oscillations (10-30 Hz) in the STN occur consistently when bradykinesia is experienced [33; 34]. Similarly, high-gamma oscillations (50-120 Hz) in the cortex are known to occur during periods of dyskinesia [35]. While aDBS has been demonstrated as providing improved symptom suppression compared to cDBS, it similarly suffers from a high burden on clinicians to manually identify stimulation parameters for each person. In fact, aDBS algorithms introduce even more parameters which also must be carefully adjusted. This combination of stimulation and algorithm parameters yields a vast parameter space with an unmanageable number of possible combinations, prohibiting aDBS from scaling to many people [36]. To make aDBS a treatment that can scale, stimulation and algorithm parameter tuning must be automated. More fundamental than automating parameter selection, however, is the need to establish that aDBS is a vital long-term treatment outside the clinic. While early studies have successfully demonstrated aDBS outside the clinic for prolonged periods, repeated trials must demonstrate therapy effectiveness before this technology can safely translate to real-world use [37; 32].

1.2 Translating aDBS Therapy to the Home

Having access to effective care at home is critical for maintaining quality of life, particularly for disorders causing mobility issues, e.g. people living with PD (PwP) [2]. The term PwP includes the person who has

PD, as well as their families or caregivers, who are all impacted in varying degrees by the extensive array of PD symptoms [38; 39]. A growing body of evidence has shown that providing care in peoples' natural environments leads to equal or better clinical outcomes, improves satisfaction, and reduces healthcare expenses [40; 41]. Establishing healthcare solutions at home also eases an otherwise untenable burden on health care practitioners (HCPs) by reducing visits to a clinic or hospital [40]. This becomes even more important for managing crises like COVID-19 when access to hospitals is limited [42].

In-home healthcare solutions become even more important when providing complex therapies such as aDBS. Research to identify person-specific behavioral and physiological markers of symptom severity is still in its early stages, and methods to capture these markers must be developed and rigorously tested. Where it is possible, automating these methods will help to reduce the burden on clinicians and researchers [43; 44]. Importantly, updating aDBS algorithms and monitoring symptom severity and treatment efficacy should be done remotely if this therapy is going to be chronically delivered for people going about their daily lives. This is even more necessary for rural or medically underserved areas [41; 45; 46].

1.2.1 Platforms for Neurotechnology Translation

Despite the promise that neurotechnologies offer for a compelling complement or alternative to pharmaceuticals to treat neurological disorders, translation timelines from lab to clinic frequently mirror those in pharma rather than the rapid timelines seen in other technology domains [47]. This is not because neurotechnology researchers lacks the interest or capacity to rapidly deliver products to market. Rather, there are several barriers specific to neurotechnology that other technology fields do not encounter. This includes economic incentive structures in healthcare, disruptions to established surgical or clinical workflows, health regulations regarding unknown mechanisms of action in the brain, and clinical adoption and patient acceptance. Each of these are a discipline in their own right and demand consideration during the development process [48].

A strategy to overcome some of these difficulties is through the use of platforms. The term platform in literature has occurred increasingly in the last 30 years across many fields including economics, management, technology, and health [49; 50]. In the context of neurotechnology, a platform is an architected system or set of systems that enable a product or technology to be accessed in the real world, such as in

clinics and hospitals [47]. This is an essential functionality, making platforms immediately highly valuable. Beyond this value, platforms could also be important for reducing translation times of bringing neurotechnologies into regular use. An important type of platform is a platform ecosystem, which enables interactions with many complementary products, thus an “ecosystem”. This type of platform has increased in literature the most in recent years [50]. A pioneering example of a platform ecosystem for neurotechnology is the Activa PC+S, an investigational platform including an implantable device to stimulate and sense, to collect data, and to run closed-loop algorithms as a prototyping tool [51]. The capabilities of these platforms and the relationships that have developed around them have massive potential to address the barriers facing neurotechnology translation; nonetheless they are not a silver bullet.

A key ingredient for a platform ecosystem to be impactful is a technology-stack. A technology-stack is the layered sub-components of a platform, including hardware, software, cloud databases, security infrastructure, and the algorithms and policies controlling device functionality [52]. Technology stacks designed to accelerate translation should simultaneously enable a platform to deliver therapeutic outcomes, and to give researchers access to data and technologies needed for scientific discoveries. Significant design challenges must be overcome in order to make a one-design-fits-many platform actually useful at providing effective treatment. This is particularly the case when academic, corporate and government interests do not align. A tangible step towards realizing such a technology-stack came from the OpenMind Academic Consortium, which seeks to lower barriers to translation through community engagement and their own design of a Platform Ecosystem. They actively develop a library of open-source software, and a template for a regulatory framework to help researchers address regulation requirements. This framework has supported several studies through a Platform Ecosystem harnessing Medtronic’s Summit RC+S system, including a cloud-based system for epilepsy, an exploratory platform for psychiatric disorders, and a neuromodulation system for neuromotor diseases [37; 53; 54].

1.2.2 Remote Symptom Monitoring

Current methods for characterizing symptom severity primarily rely on the Movement Disorders Society Unified Parkinson’s disease rating scale (MDS-UPDRS) [55]. This process relies on an expert clinical assessor to manually determine severity on a scale between 0 to 4 as they observe people performing a

suite of standardized tasks. Beyond manual symptom rating not scaling well, the UPDRS system only offers these 5 coarse categories, and is vulnerable to inconsistent ratings across clinical assessors [56]. It also cannot provide real-time continuous assessments, which are important for informing dynamic adjustments to stimulation parameters. In recent work in neural sensing research, neural signals associated with symptoms have been previously identified which may be useful for continuously tracking therapy effectiveness. We previously described two recent discoveries of neural symptom biomarkers that occur when symptoms of bradykinesia or dyskinesias are present [35; 57; 34]. In practice, however, these markers often occur transiently in non-pathological states and vary between individuals, so there is not yet a direct and reliable mapping between a single biomarker and symptoms at the within-subject level. An alternative approach is measuring symptoms through kinematic assessments of movement quality through the use of wearable sensors. Recent studies have shown that wearable sensor devices such as the Apple Watch and Parkinson's Kinetogram (PKG) can be used to estimate and track PD symptoms over time, including freezing of gait, tremor, bradykinesia, and dyskinesias [58; 59; 60; 61; 62]. However, wearable sensors are only able to detect the relative motion of the ankle- or wrist-worn device, so they do not necessarily capture complex behaviors or isolated finger movements from everyday tasks like typing or drawing [63].

Video data recorded from within the home is a possible means of addressing this gap, although manual clinical scoring of large amounts of video data is impractical. However, advancements in computer vision enables 2D or 3D kinematic trajectories to be extracted through video-derived pose-estimation [64]. Pose data could be used to analyze movement- or symptom-related features undetectable to wearable sensors such as bradykinesia-impacted finger movements, full body motion, or facial movements which pertain to emotional states. Videos additionally provide a source of ground truth labels of behaviors or symptoms through manual review of selected time points [65]. Early studies have explored pose estimation in the lab for automated evaluation of clinical state, however this must be tested in real-world environments outside the lab [58; 66; 67; 68]. Continued studies on larger cohorts are needed to validate the use of video-derived kinematics for assessing symptom severity.

1.3 At Home: The Other Side of Neurotechnology Translation and Effectiveness

More important than developing sophisticated therapies is ensuring that people living with neurological conditions are supported in managing their care and interacting with treatments we provide, such as aDBS delivered through a platform ecosystem. This is particularly critical for people living with progressive disorders such as PD, where the range of symptoms is extensive and evolving. Managing care for PwD requires HCPs from multiple branches of medicine to treat their symptoms, such as neurology, nursing, and speech or occupational therapy, psychiatric care, and central pain solutions [69; 70; 4; 3]. Meeting such varied needs is a challenge when it is not clear how such complexity should be organized, and when different health care specialties are siloed from each other [71; 72; 73].

Integrated collaborative care is a type of multi-specialty model that seeks to address these challenges by collaborating with PwP as members of an interdisciplinary care team, and by including technologies and tools (e.g. digital health technologies to support self-management) [72; 73; 74; 75]. Given the interconnected medical and social needs that PwP face, as well as the inherent change of these needs over time, integrated collaborative care plans acknowledge that PwP's lived experience is essential for developing an effectively tailored care plan [74]. This acknowledgement is substantiated by mounting neuroscience literature showing effects of lived experience on psychological processes [12; 76; 77; 14; 78; 79; 80; 81]. Moreover, PwP who are actively engaged in their healthcare are more likely to make decisions that promote their health, to adhere to treatment plans, and to report higher quality of life scores and higher functional status [75; 82; 83; 84; 85]. Symbiotically, support for self-management enables people to better engage in their healthcare, as well as leading to slower disease progression, less complications, and reduced care costs [75; 86; 87; 88]. Despite these benefits, integrated care plans are not common practice. A notable exception comes from the research consortium "Integrated Parkinson's Care Networks" (IPCN), also known as iCARE-PD, that recently formed and is conducting a pioneering multi-part study across several countries to co-design and implement an integrated collaborative care plan for PD [89; 90; 91]. The IPCN aims to recenter care in the home and community as a pragmatic solution to siloed healthcare specialties, where existing local care resources of interest to PwP can be leveraged for additional sources of support [90]. Preliminary results showed

PwP engagement levels were high, however low ratings of self-management support suggested a need for increased support in goal-setting and patient follow-up.

Positive impacts have also been demonstrated on research outcomes when PwP engage in the research process [92]. This can help ensure that research protocols are tolerable to patients [93]. Additionally, participatory research has sped up patient recruitment and reduced drop-out rates, which leads to faster trial completion and cost reduction, ultimately leading to technology translating from lab to clinic more quickly [94; 95; 96]. Nonetheless, studies engaging with PwP in the research process are still very much the exception.

1.4 The Weill Neurohub Automated Optimization of aDBS for PD Project

All of the data analyzed in this work comes from a longitudinal study for automated optimization of aDBS for Parkinson's Disease (PD). The study was funded by the Weill Neurohub, a private organization that funds projects investigating new treatments for neurological and psychiatric diseases [97]. Notably, the Weill Neurohub funds collaborative projects between the University of California, San Francisco (UCSF), the University of California, Berkeley, the University of Washington (UW), and as of 2024 the Allen Institute. The project grew out of a larger ongoing IRB and IDE approved study into aDBS led by UCSF [37]. The project's listed aims were:

- Develop an integrated system that could be deployed to the home of a person with PD for remote neural recording and optimization of aDBS.
 - Develop infrastructure for a hybrid system for automated aDBS programming.
 - Acquire data recorded from within people's homes using the deployed system.
 - Optimize aDBS stimulation parameters.
- Utilize the integrated system to track symptoms during naturalistic behaviors in order to determine whether the algorithms developed in the previous aim provide symptom relief in unconstrained daily life.
 - Monitor people while at home during naturalistic unconstrained behavior.

- Assess aDBS during naturalistic behavior.
- Identify new biomarkers of naturalistic behaviors.

1.4.1 Project Organization

The project team was comprised of one principal investigator (PI) each from UCSF, Berkeley, and UW (the PI from UCSF was also the neurologist on our team), one post-doctoral researcher and one clinical research coordinator from UCSF, and several graduate students across the three schools. While a bioethicist from UCSF was listed on the original grant proposal, they did not have any interaction with the project. While the original Weill Neurohub project aimed to enroll four participants, only one participant was enrolled throughout the two years.

The project began in April 2021 before data sharing agreements between all three schools were approved. For the first year, only the UCSF-affiliated researchers could directly interact with people who enrolled in the study, until UW-affiliated researchers were approved in April 2022. Berkeley did not obtain approval during the study. During that first year, any needed communication between the participant and the UW or Berkeley researchers was relayed strictly through UCSF researchers. In general, the clinical research coordinator primarily relayed communications between the participant and researchers until they took another position in March 2023. At that point I became the primary point of contact between the participant and researchers.

1.4.2 Positionality

Towards increasing reporting on person demographics in research, I note my positionality and briefly note some of the demographics of the people involved in this work. I am a white female European-American PhD student at an R1 research university, with research interests that include participatory action research for education and global health, integrated systems, human psychology, and anthropology. I grew up in a small town in Colorado and was home-schooled from kindergarten to 12th grade. I spent 8 years working in the culinary industry before pursuing a bachelor's degree in computer science.

The three PIs who led the project are all white male faculty members at R1 research institutions. Of the remaining 6 co-authors on the research team, 1 person was a female researcher, and the remaining 5 were

male researchers. All were affiliated with R1 research institutions.

The person who participated in our case study is an adult white male with PD who was implanted bilaterally with cylindrical leads in the STN used for stimulation and sensing, and subdural paddle-type leads straddling the central sulcus of the cortex used for sensing only.

1.4.3 Project Communication

Meetings between the entire research team were entirely remote, with the exception of one in-person 2?-day research retreat held midway through the project. All-hands meetings intended for the entire team to discuss their work were held remotely through video call once per week for 2 years. Several other meetings were held regularly between different members who collaborated on different aspects of the project. Slack was the primary forum used for communicating between meetings, and emails were used secondarily for purposes such as sending feedback on in-progress publications.

Researchers from UCSF interacted with the participant in-person when installing the platform, when calibrating cameras to support 3D pose processing, and on a few additional occasions where in-person technical support was required. Some of the researchers met with the participant remotely through video calls when initiating new aDBS experiments. The entire research team met with the participant once, during a 1-hour video call when researchers were together during the in-person retreat. A combination of email and G-Chat was used for communication between the participant and some of the researchers. The G-Chat account was used primarily to send asynchronous messages regarding requests, logistics and other topics relevant to the project.

1.4.4 Home Setup

For the majority of the project, the camera system was installed in the participant's home-office which was setup in a hallway in their house. This space was also used for the majority of experiments the participant conducted for data collection 1.1. The hallway connected directly to the kitchen, from which the participant and their family would regularly move between.

1.4.5 Set up for self-guided experiments at home

The participant conducted multiple experiments across the 2 years of the study. Experiments were pre-determined during discussions between the researchers. The steps for doing each experiment were typed into a word document and emailed to the participant, an example of which can be viewed in A.2.

1.4.6 On Terminology

For simplicity, all members of the project team will be referred to as "researchers", unless otherwise noted for clarification purposes. The pronoun "we" is generally used to refer to any or all researchers, except where denoting the author of this dissertation with initials or a first-person reference adds clarity or denotes a belief or perspective held solely by the author. I refer to the person who enrolled in our study in multiple ways throughout this dissertation. These changes reflect my learnings as this work has progressed. In chapters 2 and 3 I use the term "patient". While working on chapter 4 I learned that the person who enrolled in our study actively collaborated to generate new knowledge for this work just as the researchers did, so I chose the term "participant" to try to reflect this. By the end of the chapter however, I felt that "participant" was not an appropriately comprehensive term, so I introduce the term "expert-participant". I recognize that the researchers and the expert-participant have different roles and have different lived experiences. I chose these terminology to denote these different roles and lived experiences, and not to imply that knowledge is generated or discovered only from one type of role or lived experience. In future work, I hope to learn from the people who participate in research studies how they would like to be referred to. For now, I allow these terms to reflect my understanding as it has evolved.

1.5 Dissertation Roadmap

Chapter 2: Develop and deploy a prototype platform ecosystem for remote monitoring and evaluation

In the first chapter, we set out to design, build, and deploy an integrated system that could collect multiple data modalities, deliver updates to aDBS algorithms, and scale to multiple people's homes. The platform is composed of an integrated hardware and software ecosystem that is open-source and allows for at-home

collection of neural, inertial, and multi-camera video data. To collect videos from inside the home, I wrote a custom application that automatically initiates video recordings based on a configurable schedule. The application includes a user-facing graphical user interface (GUI) which enables an ongoing recording to be easily terminated or for upcoming recordings to be canceled. This was implemented to help protect user privacy. To ensure privacy for participant-identifiable data, the platform encrypts and transfers data through a virtual private network. The methods include time-aligning data streams and extracting pose estimates from video recordings.

To demonstrate the use of this system, we deployed this platform to the home of an individual with PD and collected data during self-guided clinical tasks and periods of free behavior over the course of 2 years. Data were recorded at sub-therapeutic, therapeutic, and supra-therapeutic stimulation amplitudes to evaluate motor symptom severity under different therapeutic conditions. These time-aligned data demonstrated that the platform is capable of synchronized at-home multi-modal data collection for therapeutic evaluation. The platform architecture may be used to collect new datasets and to study the long-term effects of DBS therapy outside the clinic. This work was published as a reusable protocol in the Journal of Visualized Experiments, and includes videos demonstrating how components of the ecosystem could be installed during an initial deployment [98]. The code for automatically recording videos based on a participant-approved schedule, and for visualizing data to ensure data alignment are publicly available on our project organization's github.

Chapter 3: Utilize data collected from the platform ecosystem to develop methods for remotely monitoring symptom severity and aDBS efficacy.

I set out to develop metrics to assess movement features including frequency, speed, and peak angular velocity from video-derived pose estimates and wearable-sensor data during a series of tasks. Tasks were predominantly a sub-selection of tasks that are used when clinicians manually rate symptom severity in-clinic using the UPDRS rating system, except for one task I selected to assess movement smoothness during our last aDBS data collection. I found that these movement features were reduced during periods when the participant was under-stimulated, and that they significantly correlated with video-based clinical scores of symptom severity that the neurologist on our team performed. These results were published in the 2023 IEEE Neural Engineering Conference [99].

Chapter 4: Investigate the participant experience during our 2-year study to provide context to our previous work and to inform future aDBS translation studies.

Towards the end of our study, I received requests from anonymous reviewers of our platform ecosystem to discuss the participant's experience interacting with our deployed system. From this catalyst, I set out to retrospectively investigate the participant's experience by conducting an exit interview, collecting field notes collected throughout the duration of the study, and performing reflexive thematic analysis on all data. My analysis demonstrates that actively viewing the participant as the Expert in living with PD, in living with DBS, and in interacting with our systems will improve the participant's experience and our research outcomes. My analysis also provides important context to our collected data and kinematic metrics. Key strategies for actively viewing study participants as experts are formulated as a guide for student researchers in future neurotechnology studies.

Chapter 5: Propose a framework for neurotechnology researchers to collaborate with the people they develop technologies for.

Actively engaging with participants in research is essential for successfully translating our neurotechnologies into people's lives and homes, however, exactly how this should be done is less clear. Furthermore, there are many ethical considerations that should be considered when designing a co-research study. Participatory action research (PAR) is a set of principles for collaborative research that is centered on participants and provides a flexible and contextually relevant framework. PAR has been adapted for many different research contexts all over the world. In this chapter, I introduce PAR and explore how its design imbues trustworthiness for generalizability. This property enables relevant learnings from PAR to *transfer* to different contexts. I present a worked example of PAR in clinical neuroscience research. Finally, I make recommendations for using PAR as a guide for conducting collaborative neurotechnology research.

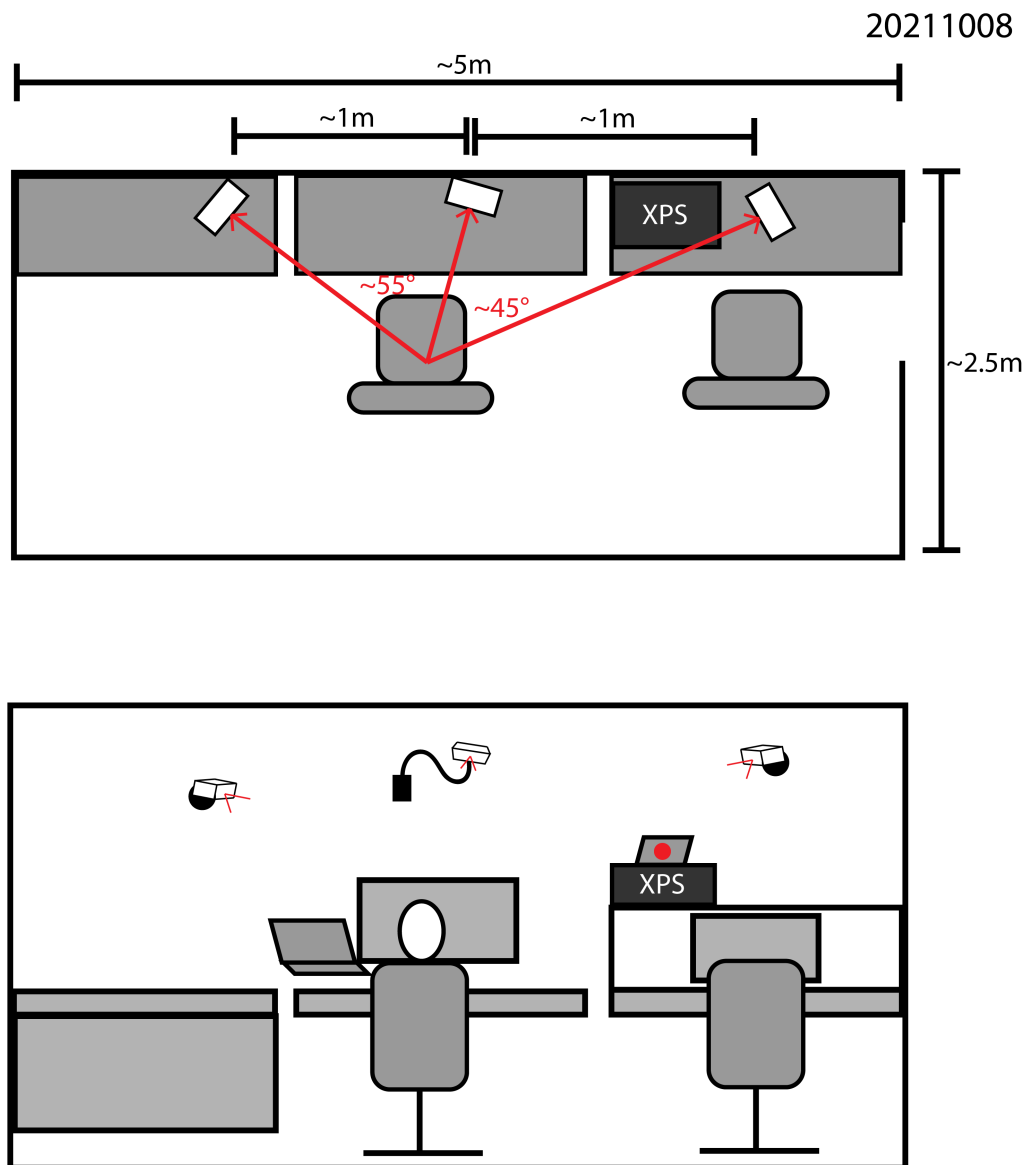

Figure 1.1: Home Office Schematic with Camera System Placement: Three webcams were placed in the participant's home office setup. The PC and touch-screen monitor (demarcated with the label 'XPS') that automatically recorded videos per a participant-approved schedule was installed near the participant's personal computer setup.

Chapter 2

Bringing the Clinic Home: An At-Home Multi-Modal Data Collection Ecosystem to Support Adaptive Deep Brain Stimulation

2.1 Introduction

This chapter includes materials originally published in [98].

Deep brain stimulation (DBS) treats neurological disorders such as Parkinson’s disease (PD) by delivering electrical current directly to specific regions in the brain. There are an estimated 8.5 million cases of PD worldwide, and DBS has proved to be a critical therapy when medication is insufficient for managing symptoms [2; 23]. However, DBS effectiveness can be constrained by side-effects that sometimes occur from stimulation that is conventionally delivered at fixed amplitude, frequency, and pulse width [31]. This open-loop implementation is not responsive to fluctuations in symptom state, resulting in stimulation settings that are not appropriately matched to the changing needs of the patient. DBS is further hindered by the time-consuming process of tuning stimulation parameters, which is currently performed manually by clinicians for each individual patient.

Adaptive DBS (aDBS) is a closed-loop approach shown to be an effective next iteration of DBS by adjusting stimulation parameters in real time whenever symptom-related biomarkers are detected [31; 26;

37]. Studies have shown beta oscillations (10-30 Hz) in the sSubthalamic nucleus (STN) occur consistently during bradykinesia, a slowing of movement that is characteristic of PD [33; 34]. Similarly, high-gamma oscillations (50-120 Hz) in the cortex are known to occur during periods of dyskinesia, an excessive and involuntary movement also commonly seen in PD [35]. Recent work has successfully administered aDBS outside the clinic for prolonged periods [37], however the long-term effectiveness of aDBS algorithms that were configured in-clinic while a patient is home has not been established.

Remote systems are needed to capture the time-varying effectiveness of these dynamic algorithms in suppressing symptoms encountered during daily living. While the dynamic stimulation approach of aDBS potentially enables a more precise treatment with reduced side-effects [31; 30], aDBS still suffers from a high burden on clinicians to manually identify stimulation parameters for each patient. In addition to the already large set of parameters to program during conventional DBS, aDBS algorithms introduce many new parameters which must also be carefully adjusted. This combination of stimulation and algorithm parameters yields a vast parameter space with an unmanageable number of possible combinations, prohibiting aDBS from scaling to many patients [36]. Even in research settings, the additional time required to configure and assess aDBS systems make it difficult to adequately optimize algorithms solely in the clinic, and remote updating of parameters is needed. To make aDBS a treatment that can scale, stimulation and algorithm parameter tuning must be automated. In addition, outcomes from therapy must be analyzed across repeated trials to establish aDBS as a viable long-term treatment outside the clinic. There is a need for a platform that can collect data for remote evaluation of therapy effectiveness, and to remotely deploy updates to aDBS algorithm parameters.

The goal of this protocol is to provide a reusable design for a multi-modal at-home data collection platform to improve aDBS effectiveness outside the clinic, and to enable this treatment to scale to a greater number of individuals (Figure 2.1). To our knowledge, it is the first data collection platform design that remotely evaluates therapeutic outcomes using in-home video cameras, wearable sensors, chronic neural signal recording, and patient-driven feedback to evaluate aDBS systems during controlled tasks and naturalistic behavior.

The platform is an ecosystem of hardware and software components built upon previously developed systems [37]. It is maintainable entirely through remote access after an initial installation of minimal hard-

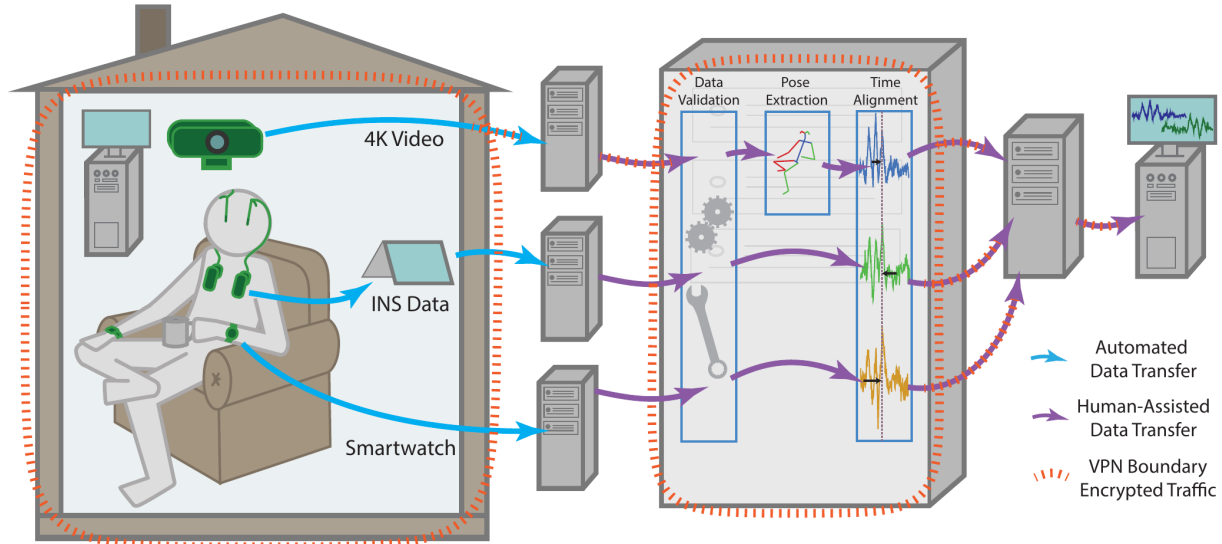

Figure 2.1: Data Flow of Platform Ecosystem: Data for each modality is collected independently from the patient’s residence before being processed and aggregated into a single remote storage endpoint. The data for each modality is sent automatically to a remote storage endpoint. It can then be retrieved, checked for validity, time aligned across modalities, as well as subjected to more modality-specific pre-processing. The compiled dataset is uploaded then to a remote storage endpoint that can be securely accessed by all team members for continued analysis. All machines with data access, especially for sensitive data such as raw video, are enclosed within a VPN that ensures all data is transferred securely and stored data is always encrypted

ware to allow multi-modal data collection from a person in the comfort of their home. A key component is the Implantable Neurostimulation System (INS) [100] which senses neural activity and delivers stimulation to the STN, and records acceleration from chest implants. For the implant used in the initial deployment, neural activity is recorded from bilateral leads implanted in the STN and also recorded from electrocorticography electrodes implanted over the motor cortex. A video recording system helps clinicians monitor symptom severity and therapy effectiveness, which includes a graphical user interface (GUI) to allow easy cancellation of ongoing recordings to protect patient privacy. Videos are processed to extract kinematic trajectories of position in two dimensional (2D) or three dimensional (3D), and smart watches are worn on both wrists to capture angular velocity and acceleration information. Importantly, all data is encrypted before being transferred to cloud storage, and the computer PC with patient-identifiable videos can only be accessed through a virtual private network (VPN). The system includes two approaches for post-hoc time-aligning of all data streams, and data is used to remotely monitor the patient’s quality of movement, and to identify

symptom-related biomarkers for refining aDBS algorithms. The video portion of this work shows the data collection process and animations of kinematic trajectories extracted from collected videos.

A number of design considerations guided the development of the protocol:

- **Ensuring Data Security and Patient Privacy:** Collecting identifiable patient data requires the utmost care in transmission and storage in order to be HIPAA [101; 102] compliant and to respect the patient's privacy in their own home. In this project, this was achieved by setting up a custom VPN to ensure privacy of all sensitive traffic between system computers.
- **Stimulation Parameter Safety Boundaries:** It is critical to ensure that the patient remains safe while trialing aDBS algorithms that may have unintended effects. The patient's INS must be configured by a clinician to have safe boundaries for stimulation parameters that do not allow for unsafe effects from over-stimulation or under-stimulation. With the INS system [100] used in this study, this feature is enabled by a clinician programmer.
- **Ensuring the Patient "Veto":** Even within 'safe' parameter limits, the daily variability of symptoms and stimulation responses may result in unpleasant situations for the patient where they dislike an algorithm under test and wish to return to normal clinical open-loop DBS. The selected INS system includes a patient telemetry module (PTM) that allows the patient to manually change their stimulation group and stimulation amplitude in milliamps. There is also an INS-connected research application that is used for remote configuration of the INS prior to data collection [103], which also enables the patient to abort aDBS trials and control their therapy.
- **Capturing Complex and Natural Behavior:** Video data was incorporated in the platform to enable clinicians to remotely monitor therapy effectiveness, and to extract kinematic trajectories from pose estimates for use in research analyses [99]. While wearable sensors are less intrusive, it is difficult to capture the full dynamic range of motion of an entire body using wearable systems alone. Videos enable the simultaneous recording of the patient's full range of motion and their symptoms over time.
- **System Usability for Patients:** Collecting at-home multi-modal data requires multiple devices to be installed and utilized in a patient's home, which could become burdensome for patients to navigate. To make the system easy to use while ensuring patient control, only the devices that are implanted or

physically attached to the patient (in this case this included the INS system and smart watches) must be manually turned on prior to initiating a recording. For devices that are separate from the patient (in this case this included data recorded from video cameras), recordings start and end automatically without requiring any patient interaction. Care was taken during GUI design to minimize the number of buttons and to avoid deep menu trees so that interactions were simple. After all devices are installed, a research coordinator showed the patient how to interact with all devices through patient-facing GUIs that are a part of each device, such as how to terminate recordings on any device and how to enter their medication history and symptom reports.

- **Data Collection Transparency:** Clearly indicating when cameras are turned on is imperative so that people know when they are being recorded and can suspend recording if they need a moment of privacy. To achieve this, we wrote a camera-system application to control video recordings with a patient-facing GUI. The GUI automatically opens when the application is started and lists the time and date of the next scheduled recording. When a recording is ongoing, a message states when the recording is scheduled to end. In the center of the GUI, a large image of a red light is displayed. The image shows the light being brightly lit whenever a recording is ongoing, and changes to a non-lit image when recordings are off.

The protocol details methods for designing, building, and deploying an at-home data collection platform, for quality-checking the data collected for completeness and robustness, and for post-processing data for use in future research. Patients are enrolled in a larger IRB and IDE approved study into aDBS at the University of California, San Francisco.

2.2 Protocol

2.2.1 At-Home System Components

Central Server & VPN

1. Acquire a PC running a Linux-based operating system dedicated to serving a VPN. House the machine in a secured room. Disk encrypt the machine to ensure data security.

2. Configure the VPN server to be publicly accessible on at least one port.

NOTE: In this case, this was achieved by collaborating with IT to give the server an externally facing static-IP address and a custom URL by the university's DNS hosting options.

3. **Server Installation:** Server installation steps should be completed once on the PC selected for serving the VPN.

- (a) **Firewall configuration:** Run the following commands in the PC terminal to install and configure Uncomplicated Firewall:

```
sudo apt install ufw
sudo ufw allow ssh
sudo ufw allow <port-number> | udp
sudo ufw enable
```

- (b) **Server VPN Installation:** Install the open-source WireGuard VPN protocol [104] on the PC and navigate to the installation directory. In the PC terminal, run `umask 007` to update directory access rules.

- (c) **Key Generation:** In the PC terminal, run

```
wg genkey | tee privatekey | wg pubkey > publickey.
```

This generates a public/private key pair for the VPN server. This public key will be shared to any client PC that connects to the VPN.

- (d) **VPN Configuration:** In the PC terminal, run `touch <interface_name>.conf` to create a configuration file, where the file name should match the name of the interface. Paste the following Server rules into this file:

```
[Interface]
PrivateKey = <contents-of-server-privatekey>
Address = ##.##.##|##
PostUp = iptables -A FORWARD -i interface_name -j ACCEPT;
iptables -t nat -A POSTROUTING -o network_interface_name -j MASQUERADE
PostDown = iptables -D FORWARD -i interface_name -j ACCEPT;
```

```
iptables -t nat -D POSTROUTING -o network_interface_name -j MASQUERADE
ListenPort = #####
[Peer]
PublicKey = <contents-of-client-publickey>
AllowedIPs = ##.##.##.##|##
```

- (e) **Activating the VPN:** Start the VPN by entering `wg-quick up <interface_name>` in the terminal. To enable the VPN protocol to automatically start whenever the PC reboots, run `systemctl enable wg-quick@ <interface_name>` in the terminal.

4. **Client Installation:** Client installation steps should be completed for each new machine that needs access to the VPN.

- (a) **Client VPN Installation:** Install the VPN protocol according to the OS-specific instructions on the WireGuard [104] download page.
- (b) **Adding a client to the VPN:** Take the public key from the configuration file generated during installation. Paste this key into the Peer section of the Server's configuration file.
- (c) **Activating the VPN:** Start the VPN per the OS-specific instructions on the WireGuard [104] download page.

Cloud Storage

Select a cloud storage site to enable all recorded data streams to be stored in one place.

NOTE: an Amazon Web Service based cloud storage site that was compatible with the selected data transfer protocol was used.

Implantable Neuromodulation System

1. Following IRB and IDE guidelines, select an implantable neuromodulation system (INS) [100] that allows patients to manually change their stimulation settings.
2. Acquire a tablet PC and install the open-source UCSF DBS application to allow for INS recordings,

reporting medications and symptoms or any other patient comments [103]. Configure INS data that is streamed to the tablet to be uploaded to a temporary HIPPA-compliant cloud storage endpoint.

Video Collection System

1. Acquire a PC capable of collecting and storing the desired amount of video files prior to transferring them to cloud storage. Ensure that the PC motherboard includes a TPM chip.

NOTE: In this case, a PC with a 500GB SSD, a 2TB HDD and a 6GB GPU was selected. A 2TB disk ensures that videos can be buffered after a lengthy recording session or in the case of losing internet connection for a couple of days, while the single PC keeps hardware minimally intrusive in the home.

2. Install the desired OS and follow prompts to enable automatic disk encryption to ensure participant privacy and to avoid data leakage.

NOTE: In this case a Linux-based OS with an Ubuntu distribution was chosen for its ease of use and reliability.

3. Separately encrypt any hard disks after the OS is installed. Be sure to enable automatic disk re-mounting upon system reboots.

4. Configure the PC's on-board TPM chip to maintain access to the disk-encrypted PC after a system reboot [105].

NOTE: If using a Linux OS, be sure to select a motherboard with a TPM2 chip installed to enable this step. If a Windows OS is used, automatic disk encryption and unlocking can be handled by the Bitlocker program.

5. Configure the PC as a VPN client by following the installation steps in the Central Server and VPN section.

NOTE: It is strongly recommended to enable the VPN protocol to automatically start whenever the PC is rebooted to ensure that researcher computers can always remotely access the PC.

6. Create a GitHub machine user account to easily automate updates to software installed on the PC. This account serves as a webhook to automate pulling from the remote git endpoint and helps identify any updates pushed from the remote machine.

7. Select software to schedule and control video recordings and install this on the PC. To maximize patient privacy and comfort, the selected software should include a graphical user interface (GUI) to clearly indicate when recordings are ongoing, and to enable easy termination of recordings at any point in time.

NOTE: If desired, the authors' custom video recording application with a patient-facing GUI can be installed by downloading the application and following instructions on GitHub (<https://github.com/Weill-Neurohub-OPTiMaL/VideoRecordingApp>).

8. Select a monitor to indicate when videos are being recorded and to enable people to easily terminate recordings (Figure 2.2).

NOTE: A monitor with touchscreen capability was selected so that recordings can be terminated without needing to operate a keyboard or mouse.

9. Install a remote desktop application on the PC. This enables running an application with a GUI such that the GUI remains visible on both the participant side and the remote researcher side.

NOTE: The open-source NoMachine remote desktop application worked best for a Linux OS.

10. Select USB-compatible webcams with sufficiently high-resolution for calculating pose in the given space.

NOTE: 4k-compatible webcams were chosen, which offers multiple resolution and framerate combinations including 4k resolution at 30fps or HD resolution at 60fps.

11. Select robust hardware for mounting webcams in the participant's home.

NOTE: Gooseneck mounts with clips that could be secured to furniture were selected to prevent the cameras from shaking.

12. Select a data transfer protocol with encryption capability and install this on the PC. Create a configuration to access your cloud storage site, then create an encryption configuration to wrap the first configuration prior to data transfer.

NOTE: In this case an open-source data transfer and file syncing protocol with encryption capability was installed [106]. The data transfer protocol documentation explains how to configure data transfer



Figure 2.2: Video recording components: The hardware components to support video data collection are minimal, including a single tower PC, USB-connected webcams, and a small monitor to display the patient-facing GUI. The monitor is touchscreen-enabled to allow easy termination of any ongoing or scheduled recordings by pressing the buttons visible on the GUI. The center of the GUI shows an image of a recording light that turns to a bright red color when video cameras are actively recording

to cloud storage. The protocol was first installed on the VPN server and an encryption configuration was created that transfers data to the offsite cloud storage site.

Wearable-Sensor Data Components

1. Select smart watches to be worn on each wrist of the patient to track signals including movement, accelerometry and heart rate.

NOTE: The Apple Watch Series 3 was selected with a built-in movement disorder symptom monitor that generates PD symptom scores such as dyskinesia and tremor scores.

2. Select and install software on each smart watch that can start and end recordings and can transfer data to cloud storage.

2.2.2 In-home configuration

Hardware Installation

1. Determine an appropriate space for mounting webcams that minimizes disruptions to the home.
NOTE: In this case, a space was determined through discussions with the patient, who chose their home office area as the optimal site for balancing recording volume against privacy.
2. Mount webcams in the identified area on the selected mounting hardware.
NOTE: In this case, clipping gooseneck mounts to nearby heavy furniture helped prevent cameras from shaking whenever someone stepped nearby.
3. Place the PC sufficiently close to the mounted webcams such that their USB cables can connect to the PC.
4. Place the tablet PC, INS components, smart watches, and smart phones near a power outlet such that all devices can stay plugged in and are ready to use at any time.

Confirm VPN Connection

Confirm that the VPN is on by running `route -n` in the PC terminal. If not, follow above instructions to activate the VPN.

Starting the Video Recording App

1. Video recording schedule: Prior to collecting any data, discuss an appropriate recording schedule with the patient. Configure this schedule on the video recording software.
NOTE: If using the author's custom video recording application, instructions for setting a schedule can be found on GitHub [<https://github.com/Weill-Neurohub-OPTiMaL/VideoRecordingAppinstallation-guide>].

2. Update recording software: Ensure that the latest version of the selected video recording software has been pulled to the PC using the GitHub machine user account installed in 1.4.6.
3. Start video recordings: Log into the PC through the installed remote desktop software and start the video recording software.

NOTE: If using the author's custom video recording application, instructions for starting the application can be found on GitHub [<https://github.com/Weill-Neurohub-OPTiMaL/VideoRecordingAppinstallation-guide>].

Video camera calibration

1. Disable autofocus: For computing intrinsic parameters such as lens and perspective distortion, follow the instructions based on the selected OS and webcams to turn off the autofocus.

NOTE: On Linux, webcams are accessed via the Video for Linux API, which by default turns on autofocus every time the computer connected to the cameras is restarted. Configuring a script to automatically disable this is necessary to preserve the focus acquired during camera calibration for processing 3D pose.

2. Intrinsic calibration: Acquire a 6x8 checkerboard pattern with 100mm squares to support 3D calibration of pose estimation software²⁰. Record a video from each individual webcam while a researcher angles the checkerboard in-frame of all cameras.

NOTE: Ensure that the checkerboard has an even number of rows and an uneven number of columns (or vice versa). This will remove ambiguity regarding rotation.

3. Extrinsic calibration: Record a video from all three webcams simultaneously. Be sure that videos are recorded at the same resolution as any videos to be processed for 3D pose estimates.

NOTE: To ensure exact time synchronization across all videos, an IR LED light was flashed at the beginning and end of the recording. Video editing software was used to manually sync the videos by marking frames at the onset of the LED and trimming the videos to an equal length.

4. Calibration matrices: Pass the videos recorded in the previous two steps through OpenPose²¹ to generate intrinsic and extrinsic calibration matrices.

NOTE: OpenPose uses the OpenCV library for camera calibration, and further instructions can be found through the documentation on the OpenPose GitHub [107; 64].

2.2.3 Data collection

Participant Instructions to Start Recording

1. Check device battery and power: The INS device is always on to provide constant stimulation for the subject. To start recording neural data, ask the participant to turn on the tablet PC and ensure that the Clinician Telemetry Modules (CTMs) for both left and right INS devices are on and fully charged.

2. CTM placement: Place the CTMs on both sides of the chest.

NOTE: For maximum connectivity and to reduce packet loss, position the CTMs close to the chest implants during recordings. They can be placed in chest pockets of a jacket, or else a specialized scarf can be used.

3. Activate tablet connection: Once the tablet has booted up, the participant should open the DBS application and select ‘Connect’, which prompts a Bluetooth connection to the CTMs and subsequently the INS devices [103].

4. Camera activation: Ask the participant to confirm that video cameras are connected to the PC through their USB cables, and that the cameras have turned on.

NOTE: If using the authors’ custom video recording application, ongoing recordings are clearly indicated on the patient-facing GUI by a large image of a red light that is brightly lit. This changes to a non-lit red light when recordings are off. The selected webcams also have a small white indicator light.

5. Smart watch activation: Ask the participant to turn on smart watches and smart phones by holding down the power button. Next, ask them to open the smart watch application to initiate data recording and PD symptom tracking.

Gesture-Based Data-Alignment and Recording Scenarios

1. Write out any desired tasks for the participant to perform during data recordings prior to starting a data collection.
2. As multi-device clock-based synchronization for aligning time stamps can be unreliable, ask the participant to perform a gesture that can be used to synchronize the time stamps from recorded data at the onset of every new recording, even when planning to record during periods of free behavior.

NOTE: The authors designed a simple gesture where the participant tapped both implanted INS devices while keeping their hands within view of the cameras. This tapping creates distinctive patterns in the inertial recordings from the smart watches and the INS accelerometer and is easy to observe in videos.

Participant Instructions to End Recording

1. Switch the stimulation group back to the participant's preferred clinically assigned group.
2. In the participant-facing GUI of the DBS application, enter a symptom report.
3. Close the DBS application, which will disconnect the CTMs and conclude INS streaming.
4. Close the smart watch recording application and return the CTMs, smartphones and smart watch devices back to their charging ports.

Data Offloading

1. Transfer raw videos to cloud storage through the data transfer protocol using an encrypted configuration. Create a cron job on the video recording PC to automatically transfer recorded videos to cloud storage through the data transfer protocol [106].

NOTE: Depending on the resolution of videos and the number of hours recorded each day, internet speed must be sufficiently high to enable all videos to be transferred to cloud storage within 24 hours. If data transfer is too slow, disk space could run out, causing additional video recordings scheduled for the following day to fail.

2. Save INS data to the HIPAA-secure cloud endpoint configured in step 1.3.2. Download INS data from the HIPAA-secure cloud endpoint and deidentify the data. Save the deidentified data to external cloud storage.

NOTE: The open source OpenMind preprocessing code [108] was utilized to deidentify data and convert it from json files to a table format. The patient's tablet was configured with a HIPAA-secure cloud endpoint for temporary storage of the raw INS data; however conceivably the same cloud storage site used for long-term storage could also be used for this step providing it is HIPAA compliant and data are encrypted prior to offloading.

3. If desired, save a copy of the smart watch data to external cloud storage so all data streams are accessible in one location.

2.2.4 System Characterization

Raw Data Visualization

In your desired coding environment, visualize all raw data streams to ensure data was recorded and transferred appropriately without loss or corruption.

NOTE: The application that was selected to manage smart watch recordings has a browser app that is helpful for visualizing smart watch data [109]

Video Frame and Timestamp Lags

Inspect any lags between timestamps generated from different webcams.

NOTE: Lags were analyzed by recording videos with a programmable LED light placed in-frame of all webcams. Analysis revealed that a video segmenting function imported by the custom video recording app was the source of increasing timestamp lags [110]. Recording videos without the segmenting function resulted in between-webcam frame and timestamp lags that did not increase over time (See Supplementary File A.3 and Supplementary Figure A.1).

2.2.5 Post-hoc Data Pre-Processing and Alignment

Pose Data

Install software to calculate joint position estimates from recorded videos.

NOTE: The OpenPose library was selected given that it included hand and face tracking in both 2D and 3D. However, OpenPose does not automatically handle cases where multiple people are in-frame, so post-processing code should be written to ensure that each person's pose estimates are continuous from one frame to the next. OpenPose provides code to easily generate animations, either in 2D or 3D, for visual checks on pose estimation quality.

Gesture-based Time alignment

For each INS device (left right), the following steps should be followed using the authors' data-alignment GUI [<https://github.com/Weill-Neurohub-OPTiMaL/ManualTimeAlignerGUI>]:

1. Read in data: Access the saved INS and smart watch accelerometry data from cloud storage for the desired data session.

NOTE: An additional time series can be added if desired. Figure 3 shows the pose position of the right middle fingertip in green.

2. Visualize data streams in GUI: Use the manual time align GUI to overlay the INS accelerometry, smart watch accelerometry, and pose data.
3. Zooming in on alignment artifacts: Zoom in to the time axis and move the viewing window to the chest tapping section of the recording. Shift the aligning time series so that the peaks from the chest taps on both the INS and smart watch time series signals are overlapping as closely as possible.

NOTE: The GUI is designed to facilitate manual alignment of arbitrary time series to a common "true" time. Figure 2.3 shows the "true" time series in blue, while the aligning time series are shown in orange and green. Key guides for GUI alignment are stated on the GitHub ReadMe [<https://github.com/Weill-Neurohub-OPTiMaL/ManualTimeAlignerGUI#time-alignment>].

4. Alignment confirmation: Move the GUI window to each of the chest tapping tasks in the recording

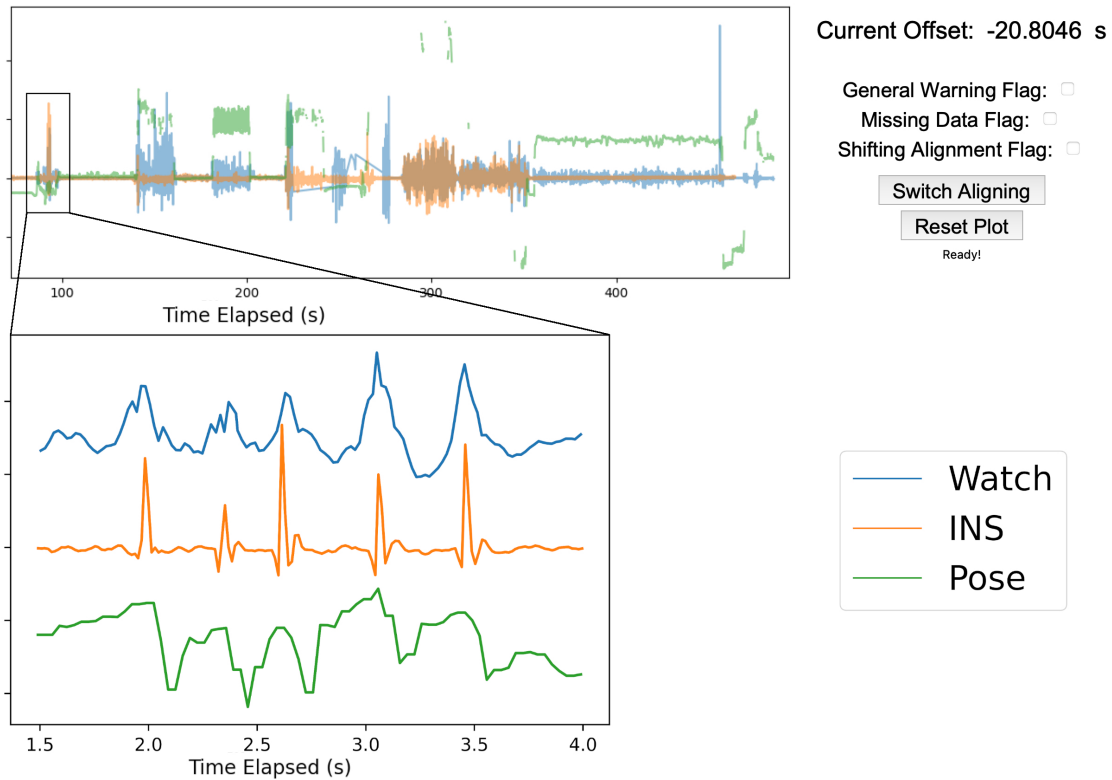

Figure 2.3: Gesture-based data alignment: The top half of the figure showcases the manual alignment GUI after aligning the three streams of data. The blue line is the smartwatch accelerometry data, the orange line is the accelerometry data from the INS, and the green line is the 2D pose position of the right middle fingertip from a single webcam. The top right shows the offset between the true time from the smart watch and INS as well as various warning flags to mark any issues that arise. In this example, the INS was 20.8 s ahead of the smartwatch. The bottom left graph is zoomed in to show the five chest taps performed by the participant for data alignment. The five peaks are sufficiently clear in each data stream to ensure proper alignment.

and confirm the alignment remains consistent throughout the time series. Press the “switch aligning” button and repeat alignments on remaining data streams.

5. Warning flags: To indicate whether data was missing, shifted, or other general warnings regarding data quality, set warning flags in the GUI using the D, S and F keys respectively.

Zero-Normalized Cross Correlation (ZNCC) Time Alignment

1. Identify the signal most likely to be closest to “true” time.

NOTE: Usually this is either the one with the highest sample frequency or the fastest internet time

refresh.

2. Resample the two signals to have the same temporal sampling frequency, and individually z-score both signals. This ensures that the resulting ZNCC scores will be normalized to between -1 and 1, giving an estimate of the level of similarity between the two signals, useful for catching errors.
3. Calculate the cross correlation of the second signal and the first signal at every time lag.
4. If phase information of the two signals is not important, take the absolute value of the measured cross correlation curve.

NOTE: If the behavior is significantly a-periodic then the phase information is not necessary, as in our case.

5. Analyze the ZNCC curve. If there is a single clear peak, with a peak ZNCC above 0.3 then the time of this peak corresponds to the time lag between the two signals. If there are multiple peaks, no clear peak, or the ZNCC score is low across all time lags, then the two signals need to be manually aligned.

2.3 Results

Prototype Platform Design and Deployment

We designed a prototype platform and deployed it to the home of a single patient 2.1. After the first installation of hardware in the home, the platform can be maintained, and data collected entirely through remote access. The INS devices, smart watches, and cameras have patient-facing applications allowing patients to start and stop recordings. The video collection hardware enables automatic video recordings after an approved schedule has been configured. Patients can easily cancel an ongoing recording by simply pressing a button on the video recording application GUI 2.2. All collected data was encrypted and transferred to a cloud storage site for researchers to process and analyze.

Data Collection

For the first deployments and data collection cycles, we asked the patient to conduct self-guided clinical tasks. The tasks were taken from the Unified Parkinson's Disease Rating Scale (UPDRS) 26, namely resting

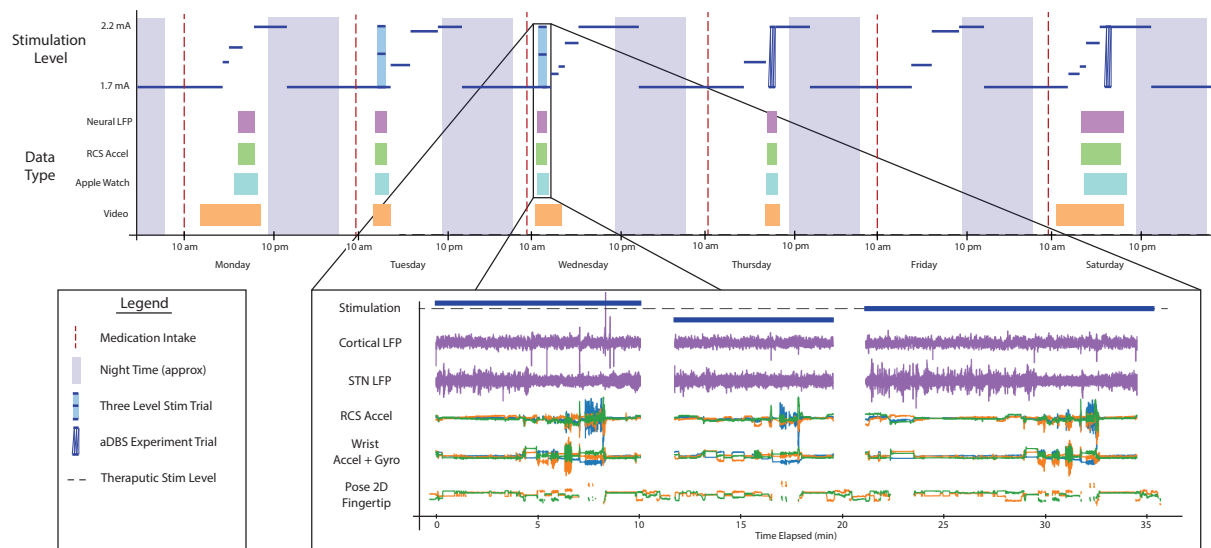

Figure 2.4: Data Availability: A schematized demonstration of what a week of data collected with the system might look like. The top plot shows the stimulation level (blue) over the course of several day/night cycles. Stimulation changes for this participant are dependent on their sleep schedule and the times of medication intake (vertical red lines). At arbitrary times throughout the day, the data collection system can be enabled remotely to collect data for multiple modalities, shown as colored boxes. One example of all the parallel, time-aligned data-streams, just down-selected to the left side of the body, is shown in the bottom plot. During this recording, the patient was asked to perform a series of clinical assessments during low, therapeutic, and high amplitude stimulation conditions. All data shown here corresponds to real data collected but has been compressed across separate experiments for ease of visualization and to show variety. Abbreviations: LFP=local field potential, STN=Subthalamic nucleus, Accel=accelerometer, Gyro=gyroscope, 2D=two-dimensional.

tremor, thumb-to-index finger tapping, hand opening and closing, wrist pronation-supination, sit-to-stand movement and walking, and a typing task. All tasks were repeated three times for each recording day. For each repetition, a different stimulation amplitude was set to expose potential stimulation-related symptoms of PD. Figure 2.4 shows a schematized example of what a week of data collected with the system might look like.

Manual Alignment

The manual alignment GUI provides an easy-to-use platform for aligning multiple streams of data. As shown in Figure 2.3, chest taps provide a clearly identifiable artifact in all data modalities (INS, smart watches, videos) that can be used in manual alignment. The GUI was a useful means of aligning the data, but this

could be exchanged for any other alignment tool that researchers would like to use. In some instances, the data streams have a slight drift. A potential future solution to this problem would be to divide the session data into different trials, each with its own chest tap sequence. Each trial can then be individually aligned to minimize the impact of drift.

Zero-Normalized Cross Correlation (ZNCC) Time Alignment

The method for ZNCC works well in some cases but it has a few critical vulnerabilities. For example, for some movements, the two accelerometer signals can be phase shifted with respect to one another. If a phase aligned and phase shifted movement are both included in the analyzed epochs, then the ZNCC can have either multiple or even no clear peak. The normalization of ZNCC allows these alignments to be automatically identified and discarded these alignments. This method works best if both signals are relatively noise free and windowed to an epoch with large, synchronized effects in both traces. The best results were achieved when the patient was asked to perform a series of strong taps with both hands against their chest. In practice however, manual verification of automated alignment was necessary for enough cases that the advantage of using the automated method was negligible.

Data Quality

Data loss during automated transfer was negligible since the data transfer protocol process backs up raw copies to ensure that any losses are recoverable. Data loss from connectivity issues occurred regularly, since Bluetooth and radio frequency sometimes have unexpected connection dropouts and are range limited. Short gaps of up to two seconds occurred approximately a few times per hour, and longer gaps of up to two minutes occurred approximately once every couple of hours. Beyond data loss, significant stimulation artifacts were observed in neural data, the severity of which depended on the recording and the stimulation groups chosen. The largest artifacts occur near the stimulation frequency, well outside ranges of interest. No artifacts were observed in data from smart watches. Videos were recorded at a constant frame rate; however duplicate frames were identified in videos. This yielded an actual frame rate a few frames less than the theoretical frame rate as stated by the webcam specifications. More noticeable than the duplicate frames however were freezing periods that were identified in videos at varying intervals depending on the recording

Data Type	Total Duration (hh:mm:ss)	Total Days	Storage Size
Neural	293:17:33	90	28.94 GB
Watch	224:06:05	89	35.67 GB
Video	2037:06:11	228	146,073.77 GB

Table 2.1: Longitudinal overview of collected data: The deployed platform collected data during several experiments over the course of 1.5 years. Approximately 90 days were recorded with neural, video, and smart watch data streams being collected.

day. Freeze periods of approximately 10 frames or less were regularly observed; however longer sections of approximately 2 to 30 seconds long were also observed at irregular periods.

Longitudinal Data Collection

Table 2.1 shows the data that the platform prototype has periodically collected over the course of a year and a half. In that time, hundreds of hours of data were collected, with a total of 293 hours of INS data across both sides of the body, 224 hours of smart watch data for both watches, and 2,037 hours of video data across three webcams. This demonstrates that the platform supports at-home data collection over extended periods of time while offering a rare opportunity to observe longitudinal changes in neural data and corresponding stimulation requirements.

2D and 3D Pose Estimates

Several pose estimation software packages are now available. Pose estimation was tested using OpenPose, an open-source software package [64]. This was successfully installed following the documentation provided by the organization’s GitHub, as well as many other unofficial tutorials found on the web. The processing time for OpenPose varies significantly based on how the OpenPose library and its extensive dependencies are installed, the size of the GPU used, and whether or not the optional hands and face key points are processed. 2D pose was relatively easy to implement, however 3D pose was notably more difficult and preliminary 3D results yielded inconsistent quality equal to that of 2D pose. The low-quality 3D pose estimation may have been impacted negatively by suboptimal camera calibration, periods where camera autofocus was erroneously turned on, or inherent in the OpenPose software itself. However, synchronized high-quality videos from multiple angles may provide rich inputs for a variety of available pose estimation

software packages. It is recommended that a test setup be completed outside of the patient's home, with manual benchmarking of different available pose estimation software packages.

2.4 Discussion

We share our design for an at-home prototype of a multi-modal data collection platform to support future research in neuromodulation research. The design is open-source and modular, such that any piece of hardware can be replaced, and any software component can be updated or changed without the overall platform collapsing. While the methods for collecting and deidentifying neural data are specific to the selected INS, the remaining methods and overall approach to behavioral data collection are agnostic to which implantable device is used. We deployed the platform to the home of an individual with PD and collected data during both experimental and naturalistic periods. During deployments, data collections and post-hoc data processing, several aspects were discovered that were particularly crucial to enabling successful research iterations.

A valuable member of our team was the research coordinator who traveled to the patient's home to install hardware, set up the VPN, performed camera calibration for 3D pose, and walked the patient through using each device's patient-facing GUI. Importantly, the research coordinator additionally served as the main point of contact between the patient and the research team. The patient preferred to use their email chat function to quickly send messages back and forth. Having a consistent and accessible point of contact was particularly helpful in two ways:

- Establishing a familiar communication channel for the patient to request changes to scheduled recordings and to communicate any difficulties in system use. This helped the research coordinator to identify convenient times for the patient to conduct recording experiments. The main difficulty in system use reported was the need to keep track of battery life for several devices.
- Allowing system troubleshooting to be minimally disruptive to the patient. Most troubleshooting stemmed from network connectivity problems which occurred on average once every couple of weeks. While rebooting devices typically resolved these issues, the watches frequently required multiple restarts, which the patient reported was burdensome.

It is essential to ensure robust remote access to the hardware placed in the patient's home. To accomplish this, having a stable internet connection is crucial. It is also necessary to configure a disk-encrypted machine to automatically unlock whenever a machine reboots. Unsurprisingly, an ethernet cable consistently yielded the fastest and most reliable network connections. Less expected was the need to configure a TPM chip, necessary due to choosing Linux as the OS. If a Windows OS is used, their Bitlocker program will take care of this automatically. Finally, configuring the deployed PC to automatically enable the VPN and re-mount the hard disk drive upon system reboots ensured continued remote access without needing to repeatedly re-visit the patient's home. Incorporating a VPN and a data encryption protocol in the platform design was pivotal for data security and integrity. The VPN allows a network of computers to be connected without needing custom port forwarding to be configured on a patient's private router. The open-source data encryption protocol Rclone program provided us with off-the-shelf data encryption and an easily automatable means of transferring data from patient devices to cloud storage [106]. The data encryption protocol makes back-up copies of raw data during its data transfer steps to ensure that losses are recoverable. These steps ensured that the patient's private data was kept secure and uncorrupted.

To be able to conduct meaningful data analysis, it is essential that the data collected from multiple devices be time aligned. The clocks on each device are likely not perfectly aligned to a common internet time, even if manufacturers suggest that they are. Additionally, some devices can experience drift at unpredictable times, changing their offsets relative to the other devices. This creates a difficulty in working towards fully automated, real-time adaptive algorithms, and future research will need to carefully consider solutions to this problem. Methods of automatic alignment were explored using normalized cross-correlation. This works reasonably well in many cases; however, time drifts must be minimal, and the data should contain clearly identifiable signals. Because both large drift and periods where data had too much noise or packet loss were encountered, this fully automated method cannot be fully relied upon. To minimize the burden of manually aligning data, we created a simple GUI to allow researchers to visually check data streams with relative ease and rapidity.

The inclusion of video data to the system enables clinicians to measure symptom severity through remote observation, and researchers can obtain event labels. In addition, pose estimates can be calculated from videos as a continuous metric of movement quality such as measuring the speed and smoothness of finger

movements over time. However, collecting high resolution videos from multiple cameras requires extensive storage space. For example, collecting 8 hours of 4k videos in the MJPEG format from three cameras takes approximately 8 TB of storage space. Recording and storing large quantities of data quickly becomes expensive, creating an economic bottleneck for deploying this system to many patients. In order to make such platforms scale to many patients, future system designers need to reduce the amount of data required for long-term storage. Future systems should consider including real-time pose processing so that videos can be promptly deleted after the pose is processed. Real-time pose could also provide feedback about fine motor skills in closed-loop algorithms, which is outside of the scope of this work. If preserving some video data is needed for clinician review or event labeling, these can be down-sampled to a lower resolution before they are saved to cloud storage.

Finally, to efficiently address the design flaws and implementation errors that invariably arise when building an integrated system, acquiring a replica of the hardware to be deployed for use as a test-rig is extremely valuable. In particular, this was true for testing the hardware and software that was selected for collecting videos and processing pose data. The entire process of acquiring videos and pose estimates in both 2D and 3D space was significantly more challenging than anticipated. A test rig allows for troubleshooting and stress-testing a number of important steps prior to deployment, including:

- Properly calibrating cameras within the layout constraints of a given room.
- Identifying the appropriate video resolution and framerate to support high quality pose estimation. For small rooms or office-like environments, HD video recording is likely sufficient, as the size of individuals on the recorded video large enough that pose can be easily computed while requiring significantly less storage space than 4K video.
- Discovering bugs in recorded videos, such as freezing frames or time lags between sequentially written video files.
- Exposing unexpected software defaults such as re-setting the camera autofocus upon machine reboots, which occludes the benefit of camera calibration.
- Trial and error to find compatible versions of the software libraries that must be pre-installed to enable OpenPose to run on a mid-sized GPU.

A particular limitation of this work is deploying the platform in a single pilot study to the home of one individual, preventing us from discovering any cross-participant generalizations from being discovered. However, throughout the design and development process, the system was designed to be scalable and support multiple deployments to support remote studies, and the purpose of this pilot study was to establish the technological feasibility of a sophisticated at-home monitoring platform. Modifying this pilot design based upon some of the discussed crucial findings and deploying the platform to more homes will allow us to further refinement of the design to support future research in at-home aDBS. In addition, collecting data during more times when an individual is not performing pre-determined experiments will offer insights to improve analyses and overall therapy effectiveness. aDBS may provide a preferable method for treating neurological diseases including PD compared to conventional DBS that can have unacceptable side-effects. Bringing this important therapy to many individuals requires automating parameter tuning and analyzing therapy effectiveness outside the clinic across time. The platform provides a novel approach to collect in-home video camera, smart watch, neural recording, and patient-report data during experimental and natural activities from the comfort of the patient's own home. The system will further contribute to creating novel multi-modal datasets to support future discoveries in the treatment of neurological diseases [111].

2.5 Acknowledgements

This material is based upon work supported by the National Science Foundation Graduate Research Fellowship Program (DGE-2140004), the Weill Neurohub, and the National Institute of Health (UH3NS100544). Any opinions, findings, and conclusions or recommendations expressed in this material are those of the author(s) and do not necessarily reflect the views of the National Science Foundation, the Weill Neurohub, or the National Institute of Health. We thank Tianjiao Zhang for his expert consultations on platform design and the incorporation of video data. We especially thank the patient for their participation in this study and for their feedback and advice on network security and platform design.

2.6 Disclosures

This study is part of a larger IRB and IDE approved study into aDBS led by the University of California San Francisco. The authors have no conflicts of interest to disclose.

Chapter 3

In-Home Video and IMU Kinematics of Self Guided Tasks

3.1 Introduction

This chapter includes materials originally published in [99].

Deep Brain Stimulation (DBS) is an important therapy for treating individuals with neurodegenerative movement disorders such as Parkinson's disease (PD). There is currently no cure for PD and symptoms cannot always be managed exclusively through medication. DBS can treat symptoms by administering electrical stimulation directly to deep brain structures, yet the precise mechanisms of action are not fully understood. DBS is conventionally administered continuously at a fixed frequency and amplitude and is thought to disrupt patterns of pathological brain activity that are active when PD symptoms occur [23; 57]. Given the brain's nonstationary nature, it is hypothesized that continuous stimulation can cause adverse side-effects during times when symptoms are minimal or not active [30; 31]. In contrast to conventional DBS, adaptive DBS (aDBS) uses disease- or symptom-related biomarkers such as subthalamic nucleus (STN) beta-band or cortical finely-tuned gamma band (FTG) activity to adjust stimulation parameters in real time [35; 34; 33; 112]. Dynamically adjusting stimulation parameters can target symptoms more precisely while minimizing adverse side effects and energy usage [30; 31]. aDBS is a relatively new approach, but several studies suggest that it is viable for application both in the clinic [113] and at home [35; 37]. However, se-

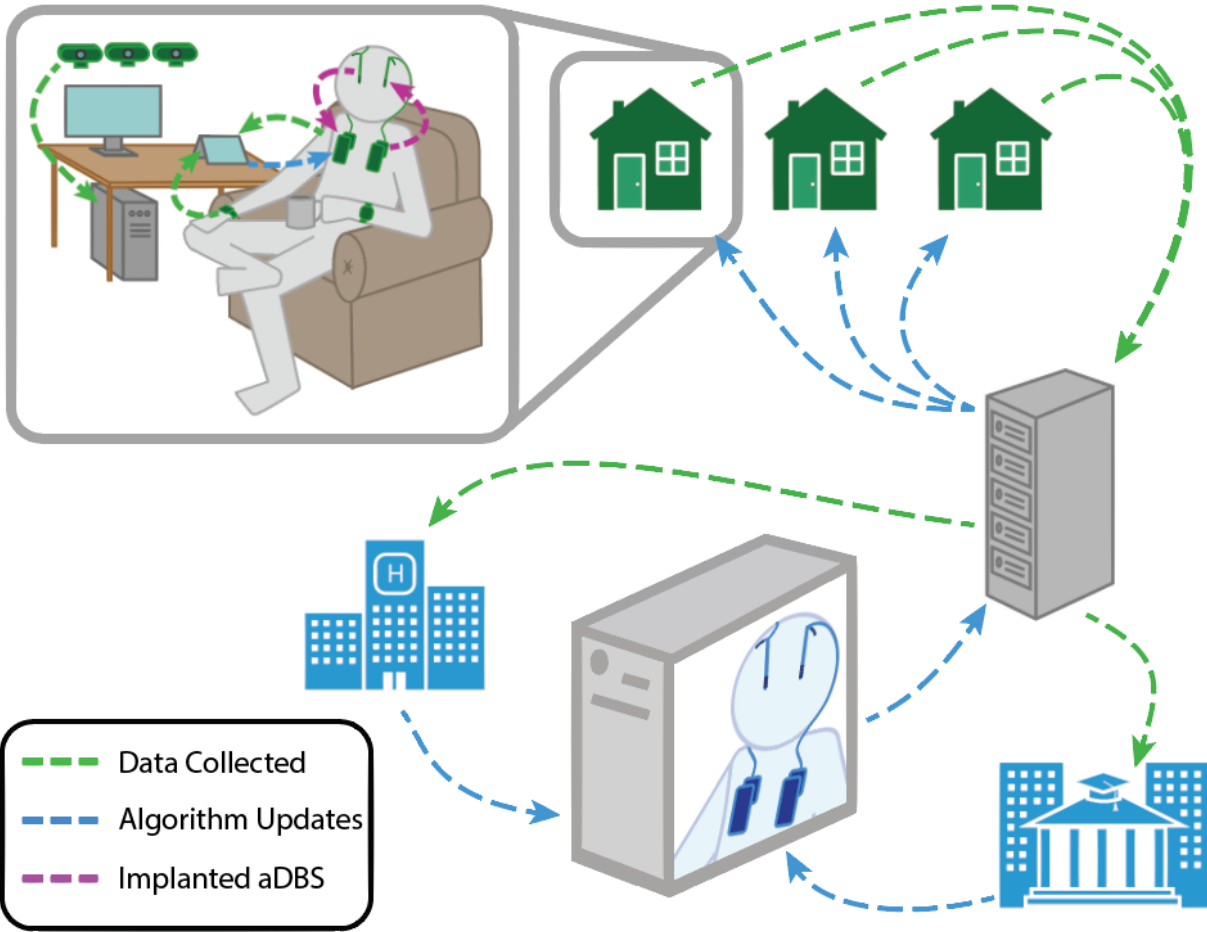

Figure 3.1: Prototype aDBS Optimization Framework: Neural, inertial, and video data are collected, time-synchronized and uploaded to a central server. Clinicians and researchers can utilize these multi-modal data streams to develop updates for aDBS therapy. These updates can then be automatically deployed through the central server back to the patient’s device.

lecting stimulation and algorithm parameters currently requires extensive manual tuning, a time-consuming process that is a major bottleneck to deployment of this technology. Conventional DBS stimulation parameters already include stimulation contacts, polarity, amplitude, pulse width, and frequency, yielding a parameter space with thousands of possible combinations [36]. This parameter space expands considerably when aDBS-specific algorithm parameters are included. There is a pressing need to develop automated systems that can identify patient-specific behavioral and physiological metrics of symptom severity outside the clinic, which are needed for optimizing therapeutic settings. Current methods of quantifying symptom severity primarily rely on the Movement Disorders Society Unified Parkinson’s disease rating scale (MDS-

UPDRS) [55], a clinical assessment of symptoms as patients perform varied tasks. This process relies on an expert clinical assessor to manually determine severity on a scale between 0 to 4. As an alternative, recent studies have shown that wearable sensors such as the Apple Watch and Parkinson’s Kinetogram (PKG) can be used to estimate and track PD symptoms over time. These symptoms include freezing of gait [58], tremor, and involuntary rapid movements known as dyskinesias [59]. However, wearable sensors are only able to detect the relative motion of the ankle- or wrist-worn device, so they do not necessarily capture complex behaviors or isolated finger movements from everyday tasks like typing or drawing [63].

In recent work in neural sensing research, neural signals associated with symptoms have been previously identified which may be useful for tracking therapy effectiveness. Two recent discoveries of neural symptom biomarkers include STN beta-band power correlated with bradykinesia, a slowness of movement characteristic of PD [57] and cortical FTG oscillations associated with dyskinesias [34]. In practice, however, these markers often occur transiently in non pathological states and vary between patients, so there is not yet a direct and reliable mapping between a single biomarker and symptoms at the within-subject level. As such, a remote data collection method for benchmarking therapies in a way that is similar to clinical evaluations is still imperative to support therapy optimization while patients go about their daily lives.

Video data collected in the home is one possible means of addressing this gap, although manual clinical scoring of large amounts of video data is impractical. However, video data enables kinematic trajectories to be extracted through computer-vision derived pose-estimation. Pose data could be used to analyze movement- or symptom-related features undetectable to wearable sensors such as bradykinesia impacted finger movements, full body motion, or facial movements which pertain to emotional states. Videos additionally provide a source of ground truth labels of behaviors or symptoms through manual review of selected time points. While early studies have started testing the viability of aDBS for long-term use [37] and are exploring pose estimation for automated evaluation of clinical state [58], no existing studies integrate neural, wearable, and video data of freely behaving patients in the home. Motivated by the potential benefits of video data, we designed an open-source prototype of a remotely accessible aDBS research platform. Our platform simultaneously collects in-home videos, inertial data, neural recordings, and patient-submitted symptom reports (Fig. 3.1). After installation in the patient’s home, the system can be maintained remotely and leveraged for remote experimental data collection during both free behavior and controlled tasks. Re-

mote management minimizes potential COVID-19 exposure while lessening the need for in-clinic visits or other disruptions to a patient’s daily life.

This chapter provides a summary of the in-home data collection platform design, and preliminary information about our experience in deploying a prototype of the platform in one patient’s home. We explored multiple features of bradykinesia using video and inertial data to illustrate how our platform can support real-time assessment of clinical symptoms. Finally, we correlated our assessments of bradykinesia with the gold standard UPDRS scores rated by the neurologist on our team.

3.2 Methods

3.2.1 Summit RC+S implantation and neural data streaming

As part of a larger IRB and IDE approved study into aDBS led by the University of California San Francisco (UCSF) [37], one adult male patient was implanted bilaterally with cylindrical leads in the subthalamic nucleus (STN) used for stimulation and sensing, and subdural paddle-type leads straddling the central sulcus of the cortex used for sensing only. Each pair of leads from a single hemisphere is connected to an investigational-use Summit RC+S Implantable Neurostimulator (INS) [100] implanted in the upper chest ipsilateral to the lead locations. Neural data is recorded at 500 Hz and accelerometry data from the INS is recorded at 64 Hz. A communication bridge that is worn by the patient transmits neural data in packets via Bluetooth to a Windows tablet. The tablet has a graphical user interface (GUI)-based application [108] that allows patients to initiate neural recordings, report symptoms, and log their medication intake.

3.2.2 Inertial Sensing

Inertial data were collected using an Apple watch model 3 worn on each wrist. Three axes of accelerometry and gyroscope data were both collected at 50Hz. Recordings were automatically uploaded to a protected health information (PHI)-compliant third-party server (Rune Labs, Inc) [114], from which the data were later accessed for analysis.

3.2.3 Video Collection System

A Dell XPS PC with an Ubuntu OS was installed in the patient's home office for in-home video collection. Video files are written to a 2TB encrypted hard disk on the PC which can buffer videos from multiple cameras during lengthy recording sessions. The large disk size accommodates dozens of hours' worth of video files which safeguards against potential loss of internet connection before files are transferred to cloud storage. The PC solid state drive is encrypted with a Trusted Platform Module chip to allow secure machine rebooting and logging in from remote. Three Logitech Brio USB-connected 4k-resolution webcams were mounted in the patient's home office. Videos were recorded with a constant frame rate of 30 frames per second and timestamps were captured for every video frame. A custom Java application controls video recordings per a patient-approved schedule, including a GUI displayed on a small touchscreen. The GUI allows the patient to easily abort any ongoing or scheduled future recordings without requiring a keyboard or mouse.

3.2.4 Security and Network Design

Multiple layers of security ensure protection of all data modalities. Neural data is streamed to a dedicated tablet and is encrypted and uploaded to a secure cloud environment operated by UCSF. The tablet runs an application used to control interactions between the tablet and the implanted device and is remotely accessible to researchers for updating therapy settings. The tablet has an additional application where the patient can choose to apply therapy updates to their device programming. Patients can also enter symptom and mediation reports into this application. The tablet is not compatible with streaming to other mobile devices, providing increased security. The PC where videos are written can only be accessed through a virtual private network (VPN) that is hosted on a private server at the University of Washington. All machines connected to the VPN are disk-encrypted, and all traffic on the VPN is additionally encrypted. Video data is encrypted and transmitted from the PC to an encrypted HIPAA compliant Wasabi cloud environment for long-term storage.

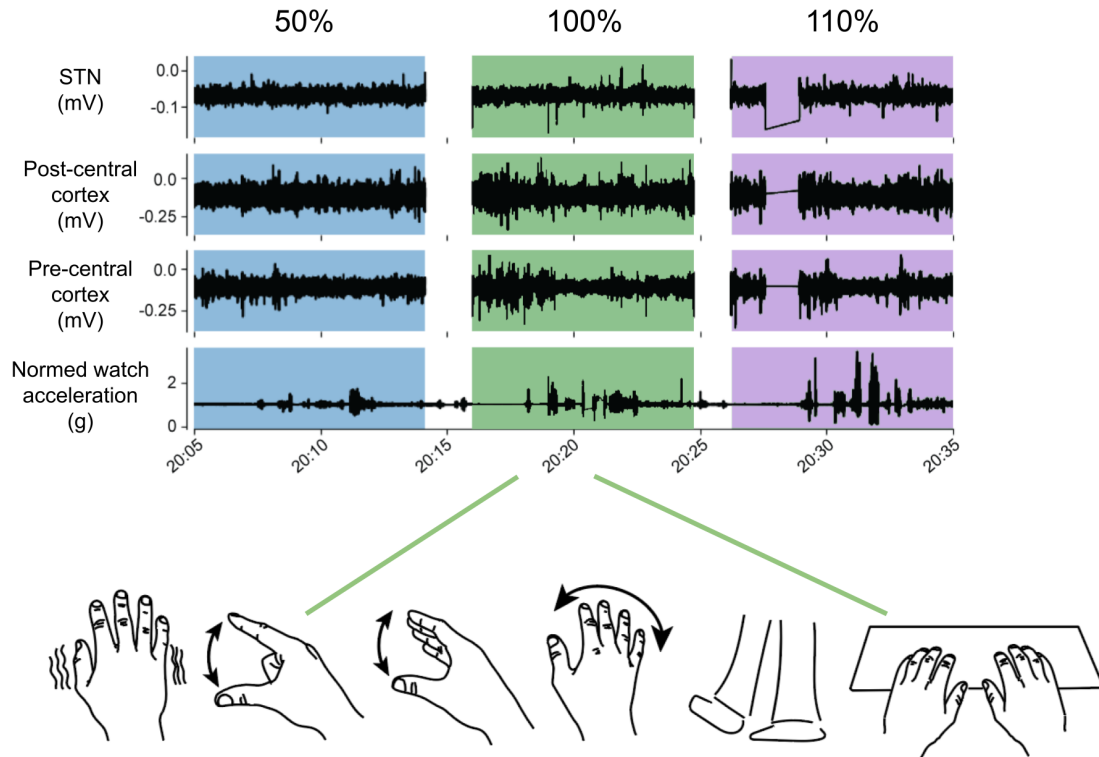

Figure 3.2: Experimental Tasks During Data Collection: We collected six sessions of data recordings for a total of approximately 45 minutes each day. Each recording day was split into three blocks with different stimulation amplitudes based on the clinically effective stimulation level. The same three stimulation amplitudes were used for each day, and the block order was permuted such that every order was tested. A series of self-guided clinical tasks taken from the Unified Parkinson’s Disease Rating Scale (UPDRS) were performed by the patient in each stimulation block. From left to right the illustrated tasks are resting tremor assessment, thumb-to-index finger tapping, hand opening and closing, wrist pronation-supination, sit-to-stand movement and walking, and a typing task. Brief periods of acclimation to the stimulation changes were included at the start of each block prior to performing the tasks.

3.2.5 Preliminary Data Collection and Controlled Experiments

We recorded a series of at-home experiments for use in clinical assessment and for exploring symptoms that can be measured at home. The series consisted of six days of recording for approximately 45 minutes each day. Data were collected from all data modalities (neural, Apple Watch and INS inertial, and video) while the subject performed a series of clinical tasks taken from the Unified Parkinson’s Disease Rating Scale (UPDRS) [55] (Figure 3.2). The tasks were resting tremor assessment (UPDRS item 3.15), thumb-to-index finger tapping (3.4), hand opening and closing (3.5), wrist pronation-supination (3.6), sit-to-stand movement (3.9) and walking (3.10), and a typing task. Each clinical task was repeated at three different stimulation

amplitudes each day to expose different symptomatic states. INS inertial data was used strictly to assist in time-aligning across modalities.

3.2.6 Gesture-based Data Alignment

It is critical that all data sources are accurately time aligned so that relationships between neural and behavioral data streams may be identified. Each of the three data sources in this multi-modal system operated on independent clocks, requiring a synchronization event to align sample timestamps. Understanding that synchronizing timestamps from the multiple clocks in each device can be unreliable, we designed a simple gesture that the patient could perform to allow for post-hoc data alignment. The patient was asked to tap their INS while keeping their hands in-frame of the video cameras. Directly tapping the INS creates distinctive patterns in the INS acceleration signals that are also clearly observable in the Apple Watch inertial signals and in the video-derived pose estimates. While future work should explore methods to use free behavior for data alignment, this current process provides a verifiable post-hoc method.

3.2.7 Apple Watch Angular Velocity for Symptom Assessment

To confirm that wearable-sensors can capture stimulation dependent behaviors at home, we analyzed peak angular velocity (v_{peak} – defined as the angular velocity at each peak) and angular displacement during the clinical hand pronation supination task. A reduction in velocity and range of motion over repeated hand pronation-supination tasks can be observed when bradykinesia is present [55; 115]. To capture limb movement and to reduce the impact of co-existent tremor, we used a fourth-order low-pass filter with a cutoff at 5 Hz (Butterworth) on angular velocity data from the Apple Watch’s on-board gyroscope. To estimate the number of pronation-supination tasks completed during each task period, we used the SciPy `find_peaks` function [116] which returns the indices of the local maxima for a given signal. A single pronation or supination is defined as the maximum slope of the angular velocity between two sequential peaks. The angular displacement of a single pronation or supination is integrated by summing the angular velocity values of a pronation or supination, multiplied by the sampling interval.

3.2.8 Video-derived Pose for Symptom Assessment

For assessing symptoms with pose estimates, we focused on the finger-tapping and hand open-close tasks. The UPDRS scores bradykinesia by looking for a slowing of speed and a reduced distance between fingertips over time. Similarly, a slowing of finger speed when repeatedly opening and closing the hand can be observed when bradykinesia is present [55]. From the collected video data, we extracted estimates of joint positions using the open-source OpenPose toolkit [64]. We completed initial implementation with 2D reconstruction from each deployed camera. OpenPose 2D output provides a confidence value for each joint position estimate, and we removed estimates below a 10% confidence threshold. To analyze the finger tapping task, we first manually identified task periods by reviewing videos. We measured the Euclidean distance between the patient’s pointer and thumb in 2D pixel space for each frame of the task period which produced an oscillatory time-series. To estimate the number of taps per task period, we used the SciPy `find_peaks` function [116] which returns the indices of the local maxima for a given signal. We defined a finger tap as the local minima of the finger distance time-series. From this, we defined an approximated tapping rate as the number of total finger taps in a task period divided by the task period duration in seconds. The task period duration in seconds is calculated as the number of data points in the distance time series, divided by the video frame rate. We performed a paired-sample permutation test, with a null hypothesis that the mean difference in tapping rates between the stimulation levels is equal to zero. During periods where the patient completed the hand open-close task, we measured the position of the patient’s middle fingertip in 2D pixel space for each frame of the video. We derived velocity as the change in position estimates per frame over each task period. We then calculated the root mean square velocity (v_{rms}) as the square root of the average squared velocity. We performed a paired-sample permutation test, with a null hypothesis that the mean difference in the v_{rms} between the stimulation levels is equal to zero.

3.2.9 Clinical Ratings and Correlation Analysis

For assessing symptoms of movement disorders, clinicians trained in the UPDRS [55] blindly scored all task periods they reviewed from videos based on the associated UPDRS task. To assess how well our symptom assessments can capture bradykinetic features, we calculated a Spearman rank correlation coefficient between the measurements from our pose- and IMU-based analyses and UPDRS scores for each task period

as rated by the neurologist on our team.

3.3 Results

3.3.1 Gesture-based data alignment

To determine the need for a data alignment method, we evaluated the differences in timestamps from each sensing system during the common artifacts produced by the gesture. This comparison of the shared event markers revealed large discrepancies in time-alignment across devices, including one extreme example where the INS accelerometry was 20.8 seconds ahead of the Apple watch accelerometry, and where video timestamps were 1.58 seconds behind the Apple watch accelerometry. This supports our prior assumption that internet-synchronization of time across consumer devices is not consistently reliable. However, the artifacts from tapping motions provided a reliable post-hoc way of aligning data between neural, inertial, and video-derived pose estimates.

3.3.2 Symptom Assessments

1. *Inertial Assessment:* To determine if these movement features can discriminate between putative symptomatic states, we plotted distributions for v_{peak} from all task periods across all 6 days and analyzed the angular displacement from each supination and pronation on a unit circle (Figure 3.3 shows the median angular displacements per task period). Because pronations occur in the opposite direction from supinations, the angular velocity is generally negative on the x and y axes. Thus, values closer to zero in for both pronations and supinations indicate a lower angular velocity of the movement. Some intermittent data drops from the Apple Watches prevented us from running paired statistical tests for all 6 days, and we chose not to run unpaired statistical tests due to variance in factors such as medication levels per day. However, clear slowing of movement can be seen between the distributions of v_{peak} at 50% vs 100% and 50% vs 110% stimulation (Figure 3.3). This corroborates the results from other studies where increasing DBS amplitude reduces bradykinesia symptoms in clinical practice [117]. The distributions for angular displacement show less overt differences, indicating that velocity may be better suited than range of motion to capture clinically relevant symptoms from a wearable

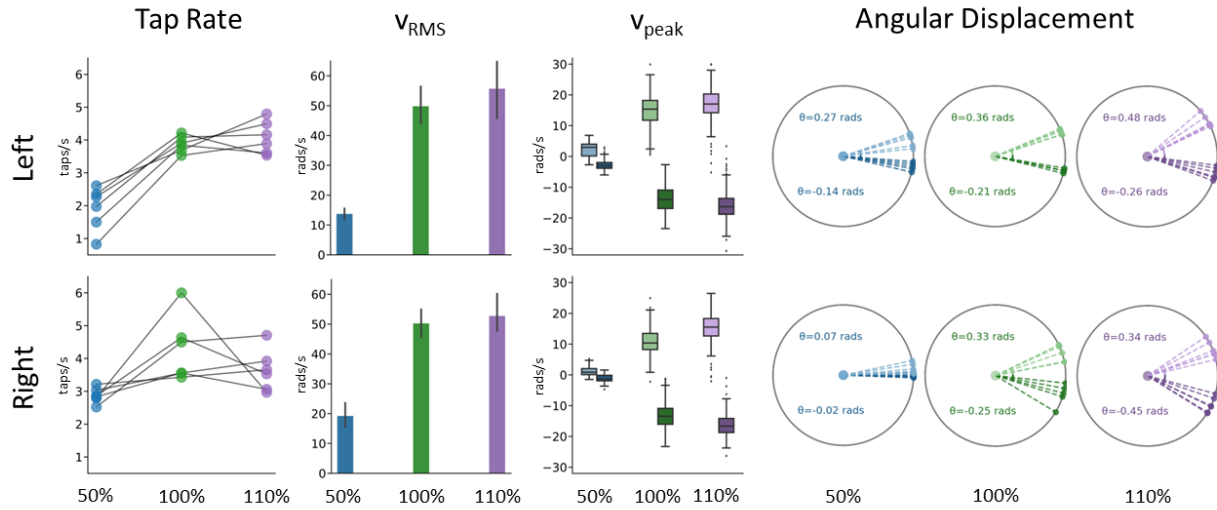

Figure 3.3: Pose and IMU Data Analyses: To explore the effects of stimulation levels during clinical tasks, we analyzed the finger tapping and hand open-close tasks from video-derived pose data and the wrist pronation-supination task from Apple Watch data from all 6 days. Reduced tap-rates, v_{rms} , v_{peak} and angular displacement can be seen during periods where the individual is at 50% of their preferred stimulation levels. The mean tap-rates and v_{rms} between periods at 50% vs 100% and between periods at 50% vs 110% preferred stimulation showed a statistically significant difference, and the mean tap-rates and v_{rms} between 100% and 110% preferred stimulation did not show a statistically significant difference. Clear differences can be seen between the distributions of v_{peak} at 50% vs 100% and 50% vs 110% stimulation, corroborating findings in other studies using inertial data to quantify Bradykinesia symptom severity. Angular displacement shows less overt differences across stimulation levels, indicating that velocity may be better suited than range of motion to capture features of Bradykinesia symptom severity from inertial sensors worn at-home.

sensor worn in natural conditions.

2. *Pose assessments:* To determine if pose data can discriminate between putative symptomatic states, we analyzed values from all 6 days for tapping rates and v_{rms} paired by day (Figure 3.3). There was a statistically significant mean increase in tapping rate between the 50% and 100% stimulation conditions (paired sample permutation test) for both the left ($p=0.031$) and right ($p=0.031$) sides. There was also a statistically significant mean increase in tapping rate between the 50% and 110% stimulation conditions (paired-sample permutation test) for both the left ($p=0.031$) and right side ($p=0.032$). There was not a statistically significant difference in tapping rate between the 100% and 110% stimulation conditions (paired sample permutation test) on either the left or right side. There was a statistically significant mean increase in v_{rms} between the 50% and 100% stimulation conditions

(paired-sample permutation test) for both the left ($p=0.031$) and right ($p=0.031$) side. There was also a statistically significant mean increase in v_{rms} between the 50% and 110% stimulation conditions (paired-sample permutation test) for both the left ($p=0.031$) and right side ($p=0.032$). There was no statistically significant mean difference in v_{rms} between the 100% and 110% stimulation conditions (paired-sample permutation test) on either the left or right side.

3. *UPDRS Score Correlations*: To test our kinematic assessments of bradykinetic features as compared to the current gold standard, we correlated our results with clinician rated UPDRS scores [55] for each task period (Figure 3.4). Tapping rates showed a statistically significant negative correlation with UPDRS scores on both the left ($\rho=-0.728$, $p=0.001$) and right ($\rho=-0.703$, $p=0.001$) sides. v_{rms} showed a statistically significant negative correlation with UPDRS scores on both the left ($\rho=-0.632$, $p=0.005$) and right ($\rho=-0.861$, $p=0.000$) sides. The mean v_{peak} of supinations showed a statistically significant negative correlation with UPDRS scores on both the left ($\rho=-0.741$, $p=0.001$) and right ($\rho=-0.775$, $p=0.000$) sides, and the mean v_{peak} of pronations showed a statistically significant positive correlation with UPDRS scores on both the left ($\rho=0.772$, $p=0.000$) and right ($\rho=0.805$, $p=0.000$) sides.

3.4 Discussion

We designed our data collection prototype to support ongoing research towards automating the optimization of aDBS algorithms in real-world settings. The prototype collects multi-modal data including video recordings to provide a behavioral complement to neural and wearable recordings that could be used in the development of adaptive stimulation algorithms. While several sources of feedback including neural markers [35; 37] and inertial data from wearable-sensors [59; 117] have successfully enabled aDBS, automating aDBS programming is an outstanding challenge due in part to the expansive stimulation parameter space, which cannot be exhaustively explored in a clinical setting alone. Developing automated methods to assess PD symptoms outside clinical observation is an important requirement to enable this next step. Platforms that can remotely capture multiple data modalities is a vital tool for determining what data are required to properly assess symptoms in future clinical deployments.

Pose estimates from video data can detect movement features that are not observable from inertial or neural signals such as isolated finger movements, providing a potentially critical component of a remote symptom assessment system. Clinicians can also compare automated symptom assessments to “ground-truth” by reviewing videos manually, which can give insights for calibrating aDBS algorithms more precisely. While collecting video data is potentially intrusive to privacy and is processing- and storage-intensive, computing pose estimation locally to avoid sharing raw videos can reduce privacy concerns.

During our preliminary data collection and analyses, we observed visibly reduced speeds and tapping rates during periods where the patient was under-stimulated. We identified potential automated behavioral metrics including video-based methods to capture isolated finger movements during the finger-tapping and hand open-close tasks. Future iterations on bradykinesia assessments could result in formalized metrics that capture clinically-actionable features based on continuous tapping rates and speeds as well as between-finger distances. Uses for pose may be extended to provide a rich collection of motor and non-motor symptom assessments to further support at-home therapy analysis. Pose could be leveraged to accurately calibrate aDBS algorithms for specific behaviors such as pointing or grasping, while neural and smart-watch signals can give feedback for adjusting stimulation in real time. This in turn would enable future work in developing automated aDBS parameter optimization techniques required by the field for clinical translation of these promising yet incredibly complicated devices.

Our prototype is open-source and modular; any one component can be removed and replaced without disrupting the other components. The progression of this study will invariably reveal as-yet unidentified needs for enabling optimized aDBS, thus a system capable of dynamic updates is necessary for long-term usefulness. By creating a secure and modular design that scales, additional patients can be enrolled in this study with minimal effort, all software tools can be updated or replaced, and algorithms can be innovated upon and updated.

This preliminary work has several limitations. We tested our prototype with a single patient, preventing any generalizations from being made regarding other patients. Until we test on the remaining patients enrolled in this study, incorporating video data only provides an example of the value of this prototype data streaming system. Our gesture based manual time synchronization and data alignment method should be automated to be scalable and to fully exploit the rich multi-modal data available for discovering symptom

metrics outside the clinic. Many of our recordings were done at times when the patient engaged in controlled experiments. Further testing during times of unstructured patient behavior will give more opportunity to improve our prototype and analytical methods.

We share this prototype to disseminate our early experiences in developing a platform designed to support future multi-modal sensing work in automating DBS and aDBS for patients with PD. We deployed our prototype to the home of a single patient and were able to collect pilot data for preliminary analyses to better guide our future work. This work has potential for supporting forthcoming efforts in automating schemes by providing a means of collecting data to support symptom assessment analysis. This system will scale for additional patients and will enable the creation of new datasets to enhance neuroscientific discovery into the causes, symptoms, and treatment of those suffering from movement disorders.

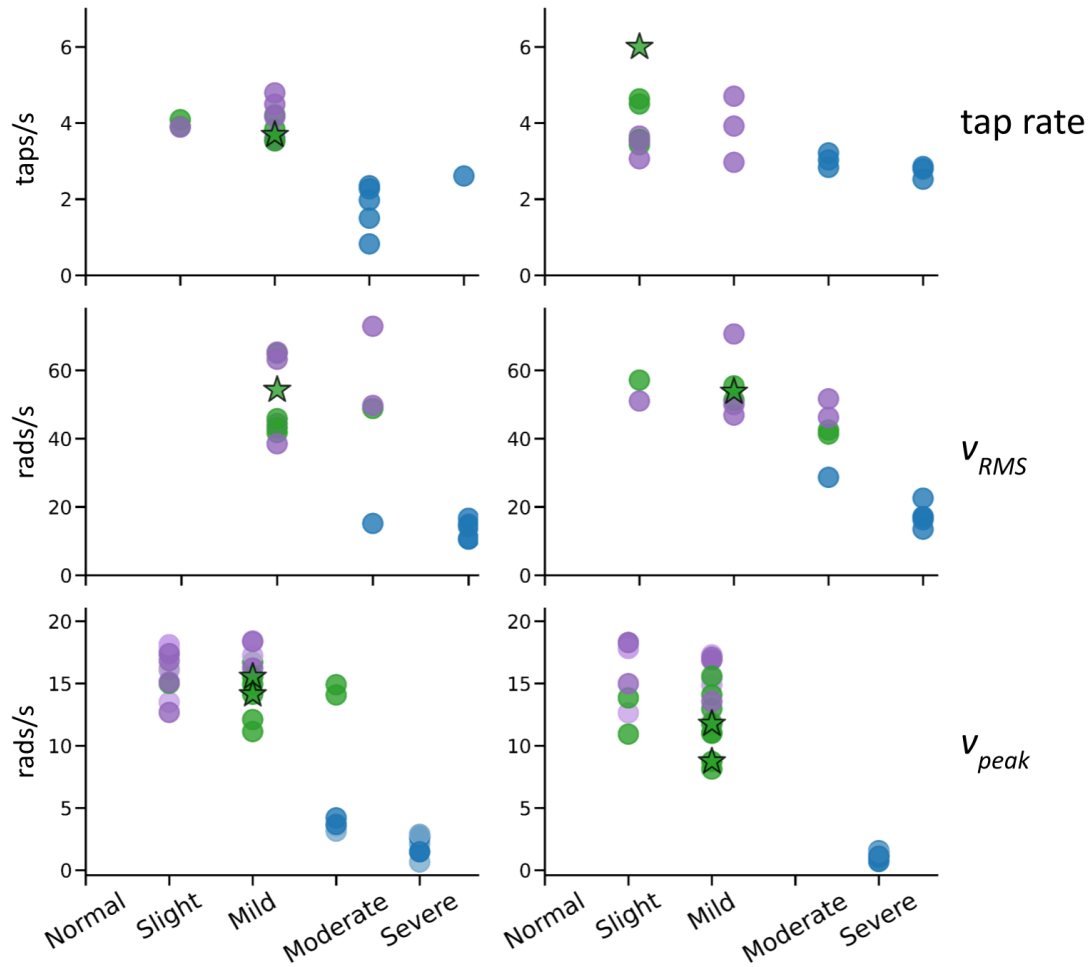

Figure 3.4: Pose and IMU Analyses Compared with UPDRS Scores: To assess our analyses against the gold-standard method to measure symptoms and disease progression, we computed a Spearman Rank Correlation Coefficient on our pose and IMU measures with the UPDRS scores rated by the neurologist on our team. Lower values for tapping rates, v_{rms} and the magnitude of v_{peak} indicate reduced task frequency and movement speeds. The blue dots reflect periods where the patient was at 50% of their preferred stimulation, and green and purple show 100% and 110% of their preferred stimulation, respectively. Data collected on the third day that was intended to be recorded at 100% preferred stimulation was erroneously recorded at 90% and is denoted with a star shape. Because pronations occur in the opposite direction from supinations, the angular velocity during pronations is generally negative. The bottom row shows the absolute value of pronations pooled with the value of supinations. Tap rates, v_{rms} and mean v_{peak} all show decreased performance wherever the patient was under-treated, and these periods were all given scores of Mild to Severe bradykinesia.

Chapter 4

The Missing Expert in Neurotechnology: Context and Expertise from the Research Participant

"Travel to a lot of different countries and you'll find a thousand different ways of thinking the world is real, all of which are just stories inside of people's heads." –Alan Kay

4.1 Introduction

We recently published a novel home-based data collection platform ecosystem and related methods that can scale to many people [98]. While preparing to disseminate this work with the research community, our anonymous reviewers asked several questions about our study participant's experience that we had not addressed in our initial approach, including:

"What was the participant's experience with system usability?"

"What was the participant's experience during hardware installation?"

"What changes did the participant or their family experience in their day-to-day routines after installation?"

"What was the participant's experience while completing the in-home experiments?"

"What were the principal areas of frustration or difficulty when interacting with the system?"

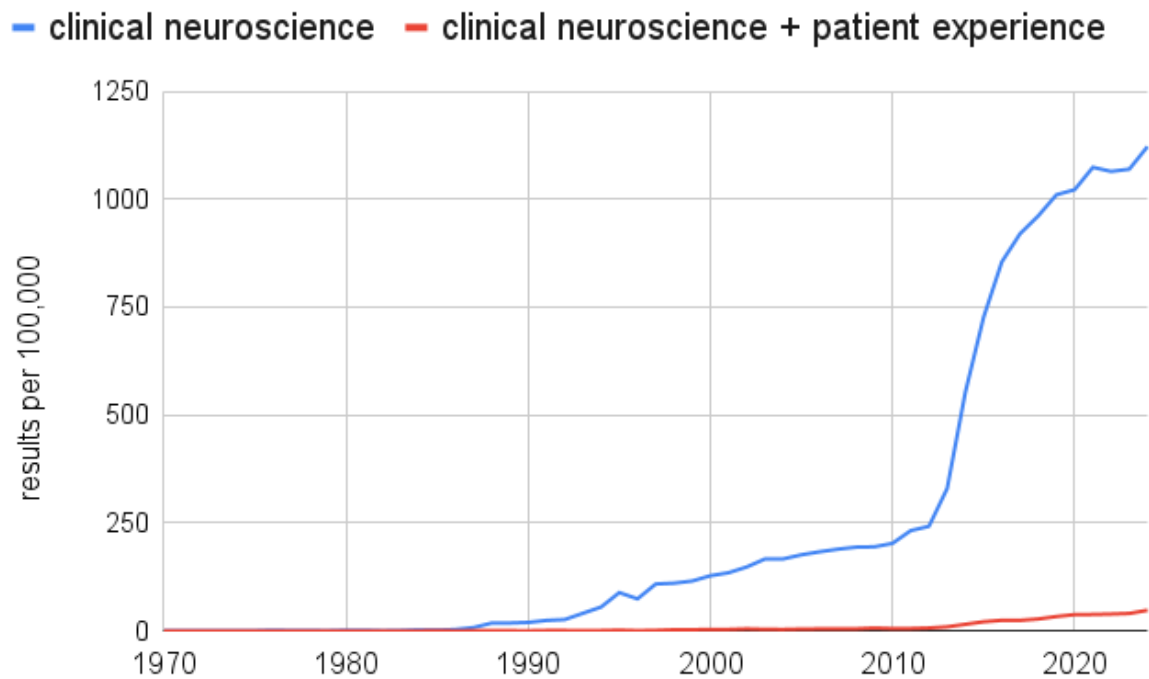

Figure 4.1: Clinical Neuroscience Citations in PubMed: These results show citation counts per 100,000 from the biomedical database PubMed, from the years 1970-2024. The blue trace shows citations with the phrase Clinical Neuroscience, and the red trace shows citations with the phrase Clinical Neuroscience *and* Patient Experience.

In short, we learned that our reviewers wanted to understand the participant’s experience with our translational work and to evaluate whether our pilot study provided adequate user support while bringing adaptive Deep Brain Stimulation (aDBS) into the home. This feedback served as a clarion call to explore the human experience *while interacting with neurotechnology systems*. While researchers in fields such as human-computer interaction (HCI) and user-centered design (UCD) have been publishing established strategies to analyze and center participants’ experiences interacting with technology for decades [118; 119; 120; 121; 122; 123; 124], these approaches are frequently excluded from a majority of *clinical neuroscience research* (Figure 4.1) [125].

For example, pioneering studies trialing aDBS in humans, and later piloting aDBS in the home, did not report on incorporating these kinds of strategies in their work [126; 127; 30; 5; 31; 35; 128; 129; 130; 37; 131; 132; 133; 99]. The reviewers’ questions underscored the importance of collecting data that captures the user’s experience interacting with technologies that transition from research labs to real-world

settings, particularly in medical contexts. Beyond developing infrastructure supporting aDBS outside the clinic, I recognized the need to ensure our systems can sustainably integrate into users' lives and support their daily needs. While some later publications do report on the participant experience in their work, many of these analyses are conducted and published separately from the "main" research foci (e.g. machine learning algorithms or biomarker discovery). There are encouraging recent exceptions to this, such as [134]'s mixed-methods study on participants' experiences to changes in their personality after undergoing DBS. Nonetheless, such studies are in the minority, and a tendency to reduce participant experience to numerical metrics persists [118; 135]. This is highly problematic for clinical neuroscience researchers, in part because *lived experience affects neural structures and functions and their related behaviors*, in direct and indirect ways [12; 13; 14; 15]. Failing to account for this impedes our efforts to properly interpret, replicate and generalize scientific findings [7; 19]. This is a critical time for aDBS researchers to utilize strategies for continually evaluating and integrating participants' experiences into their work. Doing so is essential to successfully translate neurotechnological innovations into real-world settings, and to ensure they meet practical needs and achieve their intended impact.

In this chapter, I detail the background, relevant literature, methods, and results from a retrospective analysis I conducted to investigate the participant's experience participating in our 2-year pilot study, as described in Chapter 1. This retrospective analysis was conducted at the end of the 2-year study. I first review the philosophical paradigms underlying the separation of the "quantitative" and "qualitative" approaches frequently taken in clinical research [125], including in my own prior work [99; 98]. From this, I identify how the needs of research participants may be integrated into translational clinical neurotechnology research. I then discuss my retrospective analysis, reporting the methods and results of this first-in-kind study of a participant's experience using an in-home aDBS platform ecosystem. The outcome of this study lends important context to the results of our published work, answers the inquiries of our previous reviewers, and provides recommendations that future in-home clinical neurotechnology studies can utilize to better adapt their technical solutions to the lives of the people they seek to improve. This chapter represents a significant labor of love, and an unexpected dive into the deep end of the philosophy of science.

4.2 Background

4.2.1 Spurned Ologies in Clinical Research

Neurotechnology research in humans has been ongoing for decades, from the first passively recorded human electroencephalograms (EEG) in 1924 and the first shocks of electroconvulsive therapy in 1950 [136; 137]. Since then, the field of neurotechnology has grown rapidly as clinical neuroscientists, together with technologists and engineers, have helped to restore sensory, motor and cognitive functions in humans [138]. Such impressive breakthroughs notwithstanding, neurotechnology research is still a relatively young field, especially for neurotechnology translation which endeavors to bring novel technologies from the research lab to real world settings [47; 48; 139; 140; 37]. Though bioethicists and neuroethicists have written extensively on guidelines for conducting neurotechnology research, there is no regulation or standardization specific to this field [141; 142]. Not surprisingly, many of the studies we see today follow in the footsteps of clinical research generally.

What then constitutes "good", "valid", or "effective" clinical research? Evaluating the standard of "effectiveness" or determining confirmation of "valid knowledge" in a given field is not a trivial endeavor. Moreover, it falls to the "ologies" – ontology, epistemology, axiology, methodology – to debate whether research is "valid" or whether it is nonsense. As important as validity is one's belief of what "reality" is (says ontology), and one's belief of how knowledge "comes to be" (says epistemology). These beliefs are so foundational to our every thought that we may not be cognizant of them; nonetheless, they underpin assumptions that shape the research questions we ask and how we conduct and evaluate the research itself [125; 143].

Unfortunately, it has become exceedingly difficult to ascertain the philosophical paradigms that underlie much of contemporary clinical research since these "ologies" were relegated to the "soft" science of philosophy (if included *de rigueur* as a science at all). Instead, most modern clinical research jumps directly from a research justification section ("Introduction") to a "Methods" section. Even published research from clinical trials, which has stricter criteria than general clinical studies [144], does not typically discuss its research paradigms. Though we can observe the choices that are made in a given publication and attempt to infer the underlying research paradigms, it is not clear if the researchers themselves are aware of the unstated bias in

assuming one paradigm over another [145; 12].

Clinical research, and medical research generally, has become dominated by a positivist philosophical paradigm¹ [118; 146]. Positivism considers that "reality" or "the world" exists externally to a person, and that there is a single "objective" or "true" reality that exists, regardless of whether people are aware of it or not, and regardless of whether people are able to observe or discover it.² A positivist paradigm differentiates scientific discoveries and personal experiences or value judgements. Research from a positivist approach seeks to uncover this single reality, in part by forming falsifiable research questions and testable hypotheses. Knowledge discovery must be conducted "objectively," i.e., without allowing human values to confound the findings. In this paradigm, objectively discovered knowledge is considered "true;" thus, it will generalize regardless of time passing or of changes to context.

Today, most positivist researchers recognize that our attempts at uncovering "objective reality" cannot be perfect; nonetheless, objective knowledge remains the *ideal* goal. The research process of a positivist paradigm seeks to discover new knowledge by observing the relationships between causal or independent variables and some outcome, i.e., the dependent variable. To do this, researchers endeavor to isolate and control all independent variables so that the particular variable of interest can be exposed and measured. For research outcomes to be considered valid, the research design, process, and any outcomes must reasonably support any claims of cause and effect, or causal inference, and any external "threats" to these claims (e.g., bias) should be minimized [148; 149; 150].

In this way, *positivist researchers separate themselves from the people that participate in their research study* to keep the data "emotionally neutral" and thus to isolate the "objective finding" from any personal experience or value judgement. The notion that researcher and research participant can be kept entirely separate is known as "dualism," and strict protocols are followed to minimize any bias or non-objectivity from muddling the "truth." We see the influence of this paradigm in the strict guidelines for what constitutes a randomized controlled trial (RCT) that can be single or double-blinded; the researcher is kept from the researched subject, and the researched subject is kept from the research design and process [144; 151]. The RCT has contributed monumental medical breakthroughs for society, including treating tuberculosis with

¹There is more than one type of paradigm considered to be positivist. Here, we refer to empirical positivism, sometimes called post-positivism [146].

²Heisenberg's uncertainty principle from quantum physics presents a conundrum for positivism by stating that conscious observation of an event collapses the wave function of that same event, inherently altering it [147].

streptomycin, learning prevention measures for cardiovascular disease, and establishing chemotherapy for improving survival rates in early-stage breast cancer [152; 153]. However, a growing body of research suggests that the methodologies derived from a positivist paradigm (such as with RCTs) are insufficient to properly study complex and non-static social dynamics[154; 125; 118; 155; 12; 13; 14], and in 1999 and again in 2001 the Institute of Medicine called for a redesign of care systems, based on evidence of quality failures [156].

To be clear, many other paradigms certainly exist in clinical research. Notably, these publications tend to be separated from their positivist-dominated counterparts by a single qualifier: that of what today is referred to as "qualitative research." This demarcation suggests that only positivist approaches would constitute "quantitative research." In fact, it is entirely feasible to conduct research from a positivist paradigm using non-numerical methods, and conversely to conduct research from a non-positivist paradigm using numerical methods [148; 157; 146].

Regardless, a trend has persisted where a significant majority of clinical research from non-positivist paradigms focuses on "qualitative" methods, and these studies are frequently found in separate journals. These approaches generally do not seek to separate researcher and researched (and indeed, doubt whether this dualism is possible in the first place). When published, these studies are said to evaluate the "human aspect" of clinical research. Of course, we might ask ourselves what that could possibly entail since clinical research is, first and foremost, research concerned with evaluating treatments or interventions intended for humans.

One such alternative paradigm is *interpretivism*, which touts that there is no single reality, but rather that reality is inherently subjective, that reality can be known only through social construction, and that cause and effect are mutually interdependent. Research questions in this paradigm focus on the *why* or *how* behind phenomena, not the cause and effect. Interpretivists hold that contextual factors must be taken into consideration in any systematic pursuit of understanding, and that there is inescapable interaction between the researcher and research participant [158]. The general epistemology of interpretivist researchers consider that knowledge is generative; knowledge can "emerge" through researcher–participant discourse, or it can be "developed" or "created" by a researcher or research participants' engagement [125; 159].

Because interpretivists assume that perfectly bias-free research is impossible, one of the research aims

is to notice how the researcher's thoughts, feelings, opinions and experiences influence what they observe and record. Furthermore, some interpretivist paradigms hold that researcher subjectivity is in fact an asset rather than a "threat to research validity" [145]. For example, the interpretivist methodology of reflexive thematic analysis insists that phenomena are actively developed by the researcher leveraging their subjective interpretations rather than found "hidden" in data. To quote Braun and Clarke:

"Themes are generated, created or constructed [...] they are not identified, found or discovered, and they definitely don't just "emerge" from data like a fully-grown Venus arising from the sea and arriving at the shore in Botticelli's famous painting." [159]

This approach clearly runs counter to basic tenets of positivism. Thus, it is perhaps no surprise that we so often see research from these two paradigms published in very different places and supported differently by the scientific community. In a society where value is frequently demonstrated by currency, it is noteworthy that "qualitative" research proposals within health science and in research institutes are given less funding and resources than the proposals that emphasize "quantitative" approaches to research [160].

A meaningful alternative to this seemingly hierarchical split between "quantitative" and "qualitative" – or worse, "human" and "non-human" clinical research – is found in mixed-methods research (MMR). There are several ways to structure and integrate MMR and just as many different research paradigms on which they are based. Often, MMR researchers articulate a combination of paradigms or rely on a paradigm that is based in either interpretivism or some "less extreme" relatives of positivism, such as critical realism or pragmatism.

MMR has formally existed since at least the 1960s and was based on the work of anthropologists and sociologists. It "combines elements of qualitative and quantitative research approaches for the broad purpose of increasing the breadth and depth of understanding" [161]. Four areas are considered appropriate candidates for an MM approach: (1) when concepts are new and not well understood, (2) when findings from one approach could be better understood with a second source of data, (3) when neither approach, by itself, is adequate to explain the concept being studied, and (4) when quantitative results are difficult to interpret, and qualitative data can assist with understanding the results.

Beyond merely "combining" parallel approaches into a single study, *integrating* qualitative and quanti-

tative data and research processes offers many potential gains [162; 160].

One type of MMR is *explanatory sequential design*. Researchers using this design approach collect data in two sequential stages. First, they collect and analyze quantitative data. Second, they collect non-numerical types of data to understand the potential "why" behind their quantitative findings. This approach is particularly useful when the quantitative data identifies patterns or trends but more depth and understanding is needed to explain them [162; 163]. As an example, researchers used an explanatory sequential approach to investigate why only some people who have Parkinson's disease (PwPD) experienced reduced pain sensitivity after exercising, while others actually had an association between increased physical activity and increased pain [164]. Quantitative survey results are first collected, followed by a thematic analysis of semi-structured interviews to better interpret the findings from the surveys. Researchers did not find patterns for pain management amongst people with similar pain contributors from their integrated analysis. However, they did find that the relationship between pain and physical activity varied based on PwPDs' sense of control from their thematic analysis. For studies like this, more sophisticated quantitative surveys might be necessary to capture meaningful relationships about pain.

Another type of MMR uses a *multistage framework*, where researchers use multiple stages for data collection and analysis. Each study stage can use a different design, an approach useful in longitudinal studies evaluating design, implementation, and assessment of some intervention or protocol. In the *case study framework*, both quantitative and qualitative methods for data collection and analysis are used extensively to construct a rich and thorough understanding of the case. In one example, a case study investigated why nurses typically under-report violence in the workplace. They analyzed non-numeric data from participant observation, semistructured interviews, informal field interviews and journaling, and they analyzed numeric data about violent events. Case studies can be extended to comparative case studies, such as one study exploring how clinical preventative services are delivered in family medicine offices [162]. There are also *participatory frameworks*, including *community-based participatory research* (CBPR) which focuses on social, structural, and physical dynamics, and engages community members, organizational representatives, and researchers in all aspects of the research process [162].

A common critique of MMR is that it can fail to properly "integrate" multiple discrete approaches and instead merely "cobble them together" [165]. The National Institute for Health (NIH) recommends in their

Best Practices in Mixed Methods Research in the Health Sciences (2011) that researchers ensure they clearly articulate and portray how the multiple components work together and to what end [166].

4.2.2 Implications of Paradigm Divisions for Neurotechnology Translation

The "quantitative vs qualitative" divide in most clinical research is troubling for multiple reasons. First, by limiting ourselves to researching only within the parameters valued in a single paradigm, researchers become siloed with a mere subset of methodological skills and are often entirely unaware of different *types* of research questions we could be asking [165; 125].

For example, Ingraham et al [167] used the User Preference metric to measure people's preferences and experiences wearing exoskeletons. Though exoskeleton technology had existed for decades, it was not commonly used outside of research labs; therefore, before this work, no one had attempted a formal investigation of the user experience. The User Preference method is actually a quantitative method that has been leveraged in fields like economics and business for decades, however Ingraham et al [167] notes the wearable robotics community assumed that User Preference must be a "soft, qualitative" method, and thus was not utilized in their field. Such misconceptions about methods used in other fields reflects an ill-advised willingness to dismiss methods simply for being outside of a narrow set of paradigms. This risks confinement within the bounds of what we are already familiar with rather than continuing to expand our minds, our ways of knowing, and our skill sets.

Moreover, lack of exposure to "the other" frequently contributes to suspicion, fear, and ultimately to our devaluing what is different [168]. Frequently, researchers with a background in positivist research have expressed skepticism regarding "soft qualitative" outcomes because they are subjective, do not generalize, and cannot be validated in the ways that positivism requires. I find this line of reasoning unsatisfying because it suggests that positivist researchers do not themselves bring their subjective experiences to their work and to their *interpretations* of their data analyses and research outcomes [145]. Indeed, it is through their subjective experiences conducting research that researchers develop an "expertise" in the first place. It also suggests that research produced from non-positivist paradigms may not be "valid" because it adheres to different methods for determining validity. To dismiss approaches from other paradigms based on this argument is to justify distancing ourselves from these other ways of discovering knowledge and contributing

value, rather than utilizing the full set of tools and subsequent insights that are available. Worse, we will continue to devalue any alternative approaches to knowledge discovery beyond what we already know, thus perpetuating the divide we see in clinical research and blocking ourselves from being able to synthesize truly inter-disciplinary solutions [165; 169; 118].

A refreshing exception to the trend of separating "quantitative" and "qualitative" research was published earlier this year in the *Frontiers in Human Neuroscience* journal, which frequently publishes "quantitative" clinical research [92]. To my knowledge, this is a first of its kind DBS for Parkinson's disease (PD) study that was guided by nine research participants engaging in the research process for collecting longitudinal data for informing aDBS algorithms. As is typical in current clinical research, Feldmann et al [92] did not articulate their research paradigm. Nonetheless, they state the importance of collecting *in parallel* objective *and* subjective data types to improve the ecological validity of biomarker research outcomes translating from controlled lab environments to real-world settings, suggesting something other than a purely positivist paradigm influenced their work. Their rationale for incorporating patient engagement into their design includes "successful data collection," with the specific goals of understanding participant preferences and difficulties when undergoing data collection and to more comprehensively capture their full experience, including symptoms and level of functionality.

Much of their participants' feedback is both relevant and so similar to some of my later results in this chapter that I describe some of it in detail here. A priority for many of their participants included sensors not requiring frequent recharging and the ability to wear them continuously (e.g., while showering) to avoid data loss due to forgetting to put them back on. Several people also felt that multiple parallel devices for collecting wearable sensor data was stressful. Another finding was to keep the data collection process simple and to 'gamify' experiments, ideally by featuring a score to motivate them during the game. Interestingly, they felt that active measures of movement quality are more reliable than passive ones, such as typing speeds. Several participants had clear preferences for how data should be saved and transferred, both to ensure data security and to avoid data loss. They also wanted "study support" beyond medical assistance; for example, they wanted "patient experts" to represent their perspectives and daily experiences during data collection. Intriguingly, there was also strong desire to be engaged in the entirety of the research progress, including planning, progress-update meetings, and interpreting results.

Feldmann et al [92] notes that researchers incorporated several adjustments to their study design mid-way through as they received participant feedback. A particular change was to provide desired study support. They found that engaging with participants in meetings fostered participant motivation, for example, by participants' willingness to undergo detailed input collection increased once they understood the scientific necessity of collecting this kind of data. They also found that repeated stages of engagement and study refinement, rather than only one, provided further valuable input. Finally, researchers noted the value of garnering feedback in a setting other than an informed consent conversation:

"Our impression was that the attending patients felt free to give their honest opinion, since they were considered the "experts" throughout this whole activity."

4.2.3 Participant Engagement in Clinical Research

Inspired by the work of [92], I explored the literature of impacts on clinical research outcomes when participants interact with researchers in meaningful ways that are directly related to the research process. Unfortunately, the amount of studies that report on participant engagement in any fashion is exceedingly small. Of these, what constitutes as meaningful engagement is limited, varies in terms of depth and content, and frequently focuses on a single aspect, such as recruitment, rather than a deeper exploration of participants actually engaging in research [170; 171; 172; 173]. In one example, a review paper analyzed the full text of 2,777 clinical studies between 2011 to 2016 claiming to engage with participants in the research process [171]. Of these, they only deemed 23 as actually engaging participants in research. From these, the types of engagement included developing research questions, selecting study outcomes, and disseminating or implementing results.

Another review paper surveyed literature on tools to evaluate patient engagement. Of the 10,663 unique studies identified between 1980 and 2016, a mere 27 met the reviewer's criteria for inclusion in their analysis [172]. This is notable in part because of an increase in recent literature reporting the health benefits from people actively engaging in their own health care [84; 85; 82; 83; 87; 86; 75; 88] and also because funding agencies are beginning to ask for participant engagement work to be incorporated into clinical research, with some allocating funding specifically for this endeavor [40; 73; 170; 174; 175; 176; 177; 178; 179; 180; 181].

Sacristan notes

"According to the predominant culture, research is performed on patients, not with patients. Thus, patients continue to be regarded as a source of data and not as the true protagonists in the process." [173]

Notwithstanding the relatively limited amount of work reporting on participant engagement in clinical research, studies have demonstrated that participant engagement can increase enrollment in and reduce dropouts of participants in studies [94; 182; 183; 184; 170; 185; 12]. Participant engagement can further ensure that research protocols are tolerable for participants, and researchers have further reported their work is more rewarding and enjoyable when participants are active research partners [93; 186; 173]. All of these factors contribute to studies completing more quickly, which in turn reduces costs and enables technology to translate more quickly [95; 96]. [95; 96]. A handful of studies have actually explicitly attributed participant engagement to overturning incorrect assumptions held by researchers about key study outcomes [187; 188; 189; 190].

The majority of clinical research that incorporates some level of participant engagement exists outside of the "quantitative" (and thus the majority) domain of clinical research [170]. There are some exceptions, including the work of [92] that I discussed earlier. Although qualitative clinical research has been conducted for decades, it is rarely given the same visibility or discussion space as quantitative research.

4.2.4 Who Defines Effectiveness?

For the complex realm of neurotechnology translation, an entire multidisciplinary team collaborates to design, build and deploy a complex aDBS that can meaningfully improve peoples' quality of life. To then enable this therapy to integrate into peoples' homes and day-to-day routines, we need creative and multi-faceted strategies that can address the non-stationary and interdependent dynamics of human-to-human *and* human-to-machine interactions [118; 92]. This will require immense effort, persistence, and a willingness to embrace discomfort as we grapple with how to navigate different views of "what is valid" from the many different paradigms that will exist in multi-disciplinary endeavors. Importantly, funding agencies and journal editors must lend their support if we are to succeed in such a herculean endeavor:

"Engaging in this form of research requires a new funding model wherein stakeholders value a range of paradigmatic ways of knowing beyond positivism and research that does not marginalize qualitatively driven approaches. In this model, journals must expand their word counts to make room for sufficient description of mixed methods methodologies and methods." [165]

Ultimately, we must acknowledge that what provides people with "effective" treatment or care may not be data we can readily capture in the form of "measurable outcomes". Clinicians, technologists, and other practitioners must loosen their tight grip on "measurable outcomes" as the sole definition of effective, safe, and impactful work. It is time that researchers ask the Experts living with PD, with DBS, and with the systems we deploy to their homes what meaningful research looks like.

4.3 Methodology

4.3.1 Study Design

Because we did not initially set out to conduct a mixed methods study at the beginning of the Weill project, I designed and conducted a retrospective analysis by adapting both the *explanatory sequential design* and the *exploratory sequential design* mixed method approaches [162; 191; 163]. This study explores the participant's experience during our 2-year project, and adds context to our prior aDBS translation work. First, I conducted a partially unstructured and partially semi-structured interview with the participant at the end of the study. Next, I gathered and processed field notes collected over 2 years. These include G-Chat messages between the participant and researchers, Slack chat data between researchers, and emails sent between the participant and researchers, as well as between researchers. Collaborating with 3 other researchers in my lab, I conducted a reflexive thematic analysis from these data to develop contextual and experiential themes [192; 159; 193]. I also quantified some of the topics that occurred in the G-Chat to analyze the predominant uses for text-based communication between the participant and researchers. Finally, I assessed the learnings from the thematic analysis and the quantitative measures, and formulated a set of recommendations for future studies in neurotechnology translation. These recommendations are intended for research students. They are specifically geared towards people who are primarily or solely trained in quantitative methods or who have been exposed only to a single research paradigm, particularly that of positivism.

4.3.2 Researcher Assumptions

Below, I relate the explicit beliefs I held and preferences I activated prior to designing my study.

I believe that knowledge is created, as well as discovered. Existence and occurrence of patterns can be important; however, meaning is particularly influential for developing and interpreting salient themes.

A critical orientation can offer interpretations of meaning beyond what is explicitly communicated by participants (i.e. experiential orientation). For this exploratory study, I chose to include both.

I chose to emphasize an Inductive Analysis, which is a type of analysis that uses open or initial coding without providing a predetermined list of topics in this exploratory analysis [193].

As stated by Braun and Clarke [159], I believe that subjectivity can be an asset, rather than a threat to be contained. This is appropriate within the methodology I applied during this work, including the reflexive thematic analysis method, and my epistemological belief that knowledge can be both discovered and created.

Thus, my subjective experience I bring to this analysis is not a "free for all", but rather in-line with the described methodology [192].

4.3.3 Data Collection

Exit Interview

At the end of the project, I conducted an exit interview with the participant by video call, due to the geographical distance between parties. The interview was conducted in one sitting, and lasted for approximately 1.5 hours. The interview began with an unstructured discussion reviewing the work that has been produced during the course of the study. This was followed by a semi-structured discussion guided by a set of questions that I composed A.4.

Unstructured portion of the exit interview: Our goal with this portion was to express our appreciation for the participant by sharing what their efforts had helped make possible. The participant was invited to have an unstructured "debrief" discussion, where we reviewed some of the research outcomes in figures from some of the project's publications.

Semi-structured portion of the exit interview: The primary objective of this portion was to understand how the participant's life was impacted by participating as a research subject in an at-home 2-year study so that ultimately researchers in the field can a) investigate how the experiences of research participants can

be improved in future studies, and b) explore ways that researchers can improve their research outcomes. Prior to conducting the exit interview, I asked the research team what questions they might have regarding the participant's experience beyond what our reviewers had asked. Questions asked during this discussion included:

How did the participant experience communication with us during the 2-year study?

Did the participant feel sufficiently supported when doing research?

Did the participant feel pressure to do more than they wanted, and did they want to do more or less?

Were we sufficiently accommodating and flexible to the participant's needs?

What changes would they like to see if they participated in similar future studies?

Following guidance from the BioDesign course taught at Stanford University [194], I chose a simple 4-step interview framework, and limited myself to five pre-formulated questions (A.4) to give time to discuss additional topics that might emerge organically during the interview.

Field Notes

Field notes are a data modality frequently used in fields such as ethnography and life sciences to provide relevant context to collected data. Because we did not plan to collect this data type at the start of the project, I retroactively gathered context from different sources recorded throughout our project. This included 2 years of G-Chat conversations between the participant and researchers, 2 years of Slack conversations between researchers, and emails between researchers and between the participant and researchers.

4.3.4 Data Analysis

I manually transcribed the exit interview, and no software was used for analysis.

Reflexive Thematic Analysis

I selected reflexive thematic analysis to analyze the data. General thematic analysis is one of the most established and approachable tools for conducting qualitative inquiry. Thematic analysis is based off of *codes*, which can be viewed as the “critical link” between data collection and their explanation of meaning. [193] defines a code as:

"[...] most often a word or short phrase that symbolically assigns a summative, salient, essence-capturing, and/or evocative attribute for a portion of language-based or visual data."

Codes are analyzed through the use of extended phrases or descriptions, rather than shorter codes [193]. Specifically I chose Braun and Clarke's [192] reflexive thematic analysis for developing themes from the code-book. Notably, Braun and Clarke view the analyst's subjectivity as an asset during theme development, and emphasize active *development* of themes, rather than passive *discovery* of themes [159]. For this, Braun and Clarke suggest that a reflexive thematic analysis is incomplete if the themes are readily apparent from a cursory reading of the data, and that well-developed themes are constructed through repeated and iterative cycles of critical reflection [192]. I chose this approach for two reasons. First, I am particularly positioned to leverage a critical orientation for interpreting meaning when analyzing a single interview. Relying on an experiential orientation may be more appropriate for analyzing a series of interviews conducted across the duration of a study. Second, I have experience from a researcher's perspective in designing, building and remotely maintaining a prototype system, which is useful for developing salient themes for future work in neurotechnology translation.

First Cycle Coding Process

I recruited two graduate students outside of the original study team to assist in independent coding for the thematic analysis. We independently performed a first cycle of coding following the Initial Coding or "open coding" approach. Initial Coding is an open-ended approach to reviewing the collected data for the first time. Data is broken into discrete parts and examined to identify similarities and differences and to allow the researcher to reflect on the contents [193]. We broke the transcript up first by speaker, and then by sentences within the speaker's sections. To encourage open exploration of any salient findings, we did not begin with a starting list of topics; however, I shared with the graduate students the reviewer questions from the review cycle of [98] (see A.1). During this stage, I encouraged the graduate students to tag or assign codes to any portions of the text that stood out to them and to write an accompanying reflection memo. *Reflection memos* are a way to critically reflect upon what we see in the data, and in turn they become meta-data which can also be coded in subsequent coding cycles [193]. We next met to discuss our preliminary findings, and to answer questions the researchers had regarding the context of the original

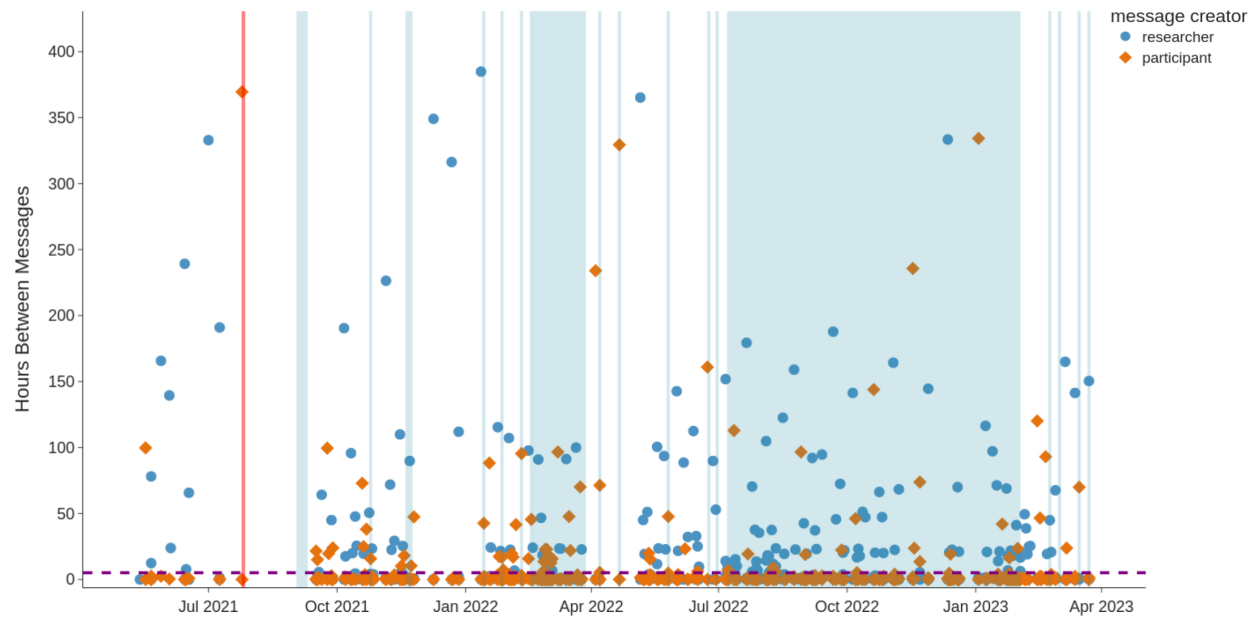

Figure 4.2: Two Years of G-Chat Activity: The amount of G-Chat messages sent between the participant and researchers was largely symmetric. The average time between messages was 5 hours (horizontal purple dashed line). The light blue shaded regions represent times that the participant recorded data from multiple streams including neural, smart watch and video data. Wider rectangles represent a range of dates where data collection efforts were actively ongoing to support specific experiments, and thin lines represent single full-day recordings. The vertical red line marks the day the platform ecosystem was first installed.

study. We performed a second independent round of coding, and again met to discuss our findings and the codes we had generated. I recruited a third student who performed an additional independent round of Initial Coding, and we met to discuss and compare their findings with the previously identified codes. From these discussions, I integrated the four sets of codes into a single code book A.5. I do not calculate an inter-rater reliability score of the codebook, as it was created through independent cycles with multiple researchers for the purposes of enriching critical reflection and theme development, rather than establishing passive findings [192].

4.3.5 Field Notes Analysis

- G-chat: I analyzed 2 years of G-Chat communications between the participant and researchers.
 - Quantifying patterns: I first identified the mean duration of time that elapsed between messages sent (Figure 4.2). To find topics of conversation, I first segmented messages into discrete "con-

versations". A new conversation "begins" when the cosine-similarity of a message is less than 0.7 compared to the previous n -messages, and if a message was *either* sent more than 5 hours after the previous message (5 hours is the mean time gap between messages), *or* if a message started with a standard greeting that included the participant's name. I then manually identified keywords or phrases in the segmented conversations and grouped these by topic (Figure 4.5). Finally, I labeled conversations that contained one or more keywords with the corresponding topic.

- Identifying context: Based on discussions I had with the graduate students during the first coding cycle, I manually selected relevant phrases that provided context to portions of the exit interview and included these for later iterations of the first cycle and for the second cycle of coding.
- Slack channels: Slack data was exported and manually reviewed by myself and one of the graduate students. Relevant information that gave context to portions of the exit interview were selected and included in the text data during the second cycle of coding the exit interview.
- Emails: These were manually reviewed by myself. Relevant information that gave context to portions of the exit interview were selected and included in the text data during the second cycle of coding the exit interview.

Second Cycle Coding and Theme Development

To help ensure that themes were fully developed, I first utilized Strauss's paradigm for axial coding to develop the transition from codes to categories [195]. Axial coding explores how codes and categories are interconnected, and is often used as a method during Second Cycle coding [193]. Strauss's paradigm for axial coding uses six sub-categories to explore when constructing categories: phenomenon, causal causation, strategies, consequences, context, and intervening conditions [195]. Upon following this paradigm, I refined initial categories through discussions with two of the graduate students who participated in the initial coding. Through multiple rounds of critical reflection and group discussions spread across 4 months, I developed 4 themes and 8 subthemes which structure the results below (Table 4.1).

4.4 Results

While pre-determined questions were posed during the course of the interview A.4, several ad hoc questions were explored by both sides during the conversation. The unstructured portion of the interview occurred first, which led to several discussion points from this portion also being discussed during the semi-structured portion. These dynamics yielded a rich dataset to explore.

4.4.1 Theme 1: Problem-solving at home to simplify everyday life

I asked the participant to share what their day-to-day experience was like since living with DBS and all its accompanying technology, as well as what their main challenges with DBS are. I also asked if they or their family experienced changes in their daily routines after the system was installed, and what their experience during data collection was like. From the discussions that followed, I learned that the participant frequently utilized their ingenuity as a means of reducing the complexities added to their daily life. These sources of added complexity include receiving DBS therapy and conducting self-guided experiments at home.

DBS technology: One source of complexity inherent to living with DBS is the need to regularly monitor the implanted neurostimulator (INS) batteries, ensuring that stimulation is delivered without interruption. The participant noted:

I've learned to not have both [sides] go out at the same time, cause that's really bad.

Rather than regularly checking the implanted INS battery levels on both sides of their body however, the participant developed a method where they only fully charge one side at a time. When the remaining side runs out of charge, that same side of their body becomes stiff and serves as their notification that it's time to charge that side. When asked whether this was a main challenge, the participant shared:

Table 4.1: Themes from Reflexive Thematic Analysis

Theme 1: At-home problem solving to simplify everyday life	Example
Subtheme 1.1: Gamifying	gamified to facilitate conducting experiments in shared family spaces
Theme 2: The Mismatch Effect: The Costs of Structuring an at-home aDBS for PD study as a traditional clinical study	
Subtheme 2.1: Theory vs Reality of Collecting Clean Data	"choice I had to make...never sure what to do"
Subtheme 2.2: Theory vs Reality of Participant Engagement in Research	Created experiment guide, generated insights and solutions, felt ownership/responsibility, and much more....
Subtheme 2.3: In-house tech support required	researcher statement of "you're not obligated to help" did not match with participants frequent assistance of tech support per researchers frequent requests
Theme 3: The affects of When, Where and How on What gets communicated	
Subtheme 3.1: Insights from Chipotle: context and conditions for effective communication	nervousness, minimized frequency, didn't want to burden
Subtheme 3.2: Researcher uncertainty regarding how to communicate with the participant	chipotle anecdote, all the things in interview
Theme 4: Who is the Person in Personalized Medicine?	
Subtheme 4.1: Needs, preferences and treatment priorities	Missed their preference for comms channel,
Subtheme 4.2: An adaptive "normal": The Missing Expert in receiving DBS, living with PD, and being a person in "Personalized Medicine"	didn't consider disability when designing exp tasks

it sounds ridiculous, but it's not so bad to be frozen on half your body, and if it was bad enough I would actually set a schedule and try to remember to check the batteries...but I just don't think about it. I don't think it even counts as a challenge because it's easy enough and I just let it run out.

For this case, their method of using their body as a charge-reminder gives them one less thing they have to proactively keep track of.

Another battery-related complication was the charging efficiency in the right-side battery. It continued to charge with poorer efficiency compared to the left-side, and compared to its performance when it was first implanted despite the participant trying to swap out some parts. The participant shared that they worried about the situation becoming worse.

An additional source of complexity comes from the number of individual pieces of hardware that make up the platform ecosystem. There are multiple components to keep track of and, for many of them, to keep sufficiently charged for data collection (e.g. two smart watches and their corresponding smart phones). To ease this burden, the participant shared that they built a shelf in their home office where they conducted experiments to store several of the smaller pieces of hardware. They utilized velcro to keep some of the pieces securely in place.

Conducting self-guided experiments at home: In the two years that the platform was deployed to their home, the participant frequently conducted experiments while streaming data from the INS system, smart watches, and videos. The experiments were some set of pre-determined movements that were usually done on one side of the body at a time, and all the movements were repeated while the participant's stimulation amplitude was set at different levels. Some of the experiments required alternating between the left and right sides up to 45 times. To ease the process of remembering all the tasks and times to switch sides, the participant created an experiment guide that they had created for themselves 4.3:

*I made a thing that was like a slideshow; there was (sic) the delays and the waits and the taps. Like I made a thing about this!
To remember left hand right hand, all the motions.*

In identifying and then fulfilling their need for an experiment guide, they simplified the experiment process by removing the need to consciously track task switches or body sides. Additionally, they reduced the likelihood that an experiment would have to be re-done should they forget any part of the experiment. This is not a trivial benefit. During the last experiment of the study, researchers aimed to record across 12 days. However, due to various mishaps that occurred, the experiment was done a total of 32 times before we were able to acquire 12 days without any issues. Due to a multitude of technical and personal factors, on both the researchers' and participant's sides, those 32 days were spread out across 7 months. While most of the 20 discarded days were due to problems other than the participant forgetting a task on some side of the body, any means of minimizing the number of times that an experiment has to be repeated is highly valuable. This saves time, money and other things more difficult to measure, such as fatigue or frustration from needing to continually re-record. Creating an experiment guide was a simple strategy to improve the chances of successfully recording an experiment, and the participant identified and took initiative to implement this.

Because the participant was made aware that having multiple people in videos created ambiguity for the pose processing software (Open Pose), they endeavored to keep the area they did experiments in clear of other people. During the interview, they shared a joke they had with their family that helped to facilitate this:

*as far as schedules it was fine, just tell everyone to stay out of the hallway or you'll get OpenPose'd.
It was fun to threaten them that if they came near they would get recognized as another person instead of me.*



Figure 4.3: Participant-Created Guide for Conducting Self-Guided Experiments: This is an example from the experiment guide that the participant created. The slideshow walks them through switching to a new task or side of the body at the precise times given in the experiment protocol. This alleviates the participant from needing to manually keep track of this while doing the experiment, and increases the likelihood of successfully completing an experiment.

Subtheme 1.1 Gamifying

I use the word *gamify* to reference a phenomena that occurred repeatedly throughout the interview, where the participant would frequently make a game out of tasks or situations in various contexts.

One example was their use of the concept "recharging your shields" in a video game they play with their family. The participant uses this phrase to refer to when they are recharging their INS battery:

that's what I call DBS recharging in the house, just recharging my shields.

Using a reference to a game played by their family is a clever way to bring levity to the increased complexity added to their daily life, and a way to bridge the lived experience gap between themselves and others who do not have PD.

In another example, they "gamified the game" when doing experiments for a different concurrent study

that involved periods of waiting for a screen to change. This task was described as being "boring as hell", so they learned the number of seconds between screen changes and took a short nap in the interim. We discussed ways to try and improve the experience. The participant suggested a speed run where the person has to race through a task and they could see their runtime. This suggests that having some score or indicator of performance could be used to gamify the experience. From finding ways to do experiments in common living spaces, to gamifying the routine of being down while charging batteries, to making a game out of a boring experiment 'game', the participant frequently utilized gamifying.

4.4.2 Theme 2: The Mismatch Effect: The Costs of Structuring an at-home aDBS for PD study as a traditional clinical study

This theme considers the impact of study design and underlying research paradigms in shaping our project. There isn't a single definition for a clinical study, and there are many ways to do so. By "traditional clinical study", I mean research practices that are commonly followed in the majority of the clinical research, such as excluding participants from the research and design processes to facilitate blinded experiments with minimal bias [125; 156].

Subtheme 2.1: Theory vs Reality of Collecting Clean Data

As previously noted, a fundamental tenet of modern science is the importance of collecting "clean" data that is as free as possible from bias or other sources of "noise." While reviewing a figure of kinematic assessments of movement quality (see Figure 3.3 in Chapter 3) in [99] during the unstructured portion of the interview, the participant recalled their experience performing the wrist-rotation task represented³:

participant: *That was a choice I had to make, and I was never really sure what to do. The instructions always [said] go as fast and as far as you can.*

researcher: *Can you say that again, one more time?*

participant: *So it was a trade-off [...], if I'm limited motion I could, you know,*

³Instructions for performing the experiment tasks were relayed to the participant in an experiment protocol document that the researchers wrote and sent them via email. An example protocol can be seen in the Appendix A.2.

do what it takes to sort of get to this point, and then do what it takes to get it back, and then try to maintain the [top] speed [...].

researcher: *But not both, you can't do both, probably.*

participant: *Right, so when movement is limited, you could have told me to [...] always hit 180, whatever it takes, as fast as you can, but definitely hit the [extremes]. Or, as fast as you can [...] for 20 seconds. So there's a bit of freedom there that...I'm sorry.*

The participant also relayed their uncertainty when conducting the finger tapping task:

When I'm in limited motion, putting these [middle, ring and little] fingers together, and treating [them] like 1 big finger, made it easier. If you'd said queue the fingers up, and only do the index down, that would have been different from me choosing whether I could do that, or whether I had to gang them together. There's a little bit of choice in the finger-tap, big choice in the [wrist-rotation].

In following up on this surprising discovery, I found that the participant did not recall which choice they ended up making during a given experimental recording.

The one task that was not directly taken from the UPDRS was a nose-tapping task inspired by prior work assessing movement "smoothness" to differentiate between voluntary and Parkinsonian bradykinesia [196]. Notably, this was a task the participant mentioned was free of ambiguity:

It doesn't come up so much with nose taps [...] that one's clean. That one doesn't have this ambiguity.

A notable factor is at play here: a task designed and articulated by someone without PD may not be understood or executed by someone with PD in the same way that the designer intended it to be. Indeed,

the designer may not be aware of such trade-offs to be able to account for this, whether in the task design or in the instructions for doing the task [18]. While most of the tasks we chose replicated those in the UPDRS rating system [55], these tasks were designed to be performed under clinical observation rather than under self-guided contexts. By not including the participant in our processes of designing, and later writing, experiment tasks, we did not account in our written instructions for the trade-offs that they confronted when performing experimental tasks when "in limited motion".

A natural question arises of why the participant did not convey their uncertainty to the researchers at some point during the study. Communication channels existed between researchers and the participant, including email and G-Chat, yet it did not come to light until the exit interview. We reflected together on this later in the interview:

researcher: *I guess I'm kind of thinking chatting with you now that it would have been helpful, even for me, to maybe hear how things were on your side a little more regularly cause you had some questions [...] on your end that we didn't know you had, like the ambiguity of the movement for example.*

participant: *Yeah why didn't we talk about that, I don't know, sorry.*

researcher: *Why didn't we? I didn't even think of it, but I think...some means of like, getting a more regular check in, could be useful.*

participant: *yeah its embarrassing that, why didn't I come up, maybe if there was [...] a protocol debriefing meeting [...] all together and I make sure you've explained how many seconds you want between repetitions here [...] follow up on what's ambiguous in here. If someone had asked me, what's ambiguous in here, I would have spoke.*

The participant notes something important: had researchers asked them what was ambiguous, potentially in the context of a "protocol debriefing meeting all together", they "would have spoke". This suggests that there are some necessary conditions for effective communication to occur, as discussed in the previous theme. It is also worth remembering that natural human language, whether written or spoken, is often rife

with ambiguity. Ensuring that the intent of the speaker or writer is actually understood by the listener or reader is not a trivial task. In other words, even if we had tried to account for the trade-off in our experiment protocol, it's still possible this would not have come through in our writing.

In reviewing field notes, I encountered the following conversation between a graduate student researcher and one of the PIs:

researcher: *We'd [the graduate student researchers] like to have an informal chat with the patient to get their thoughts on how to make the recordings as pleasant as possible, given that the November 2021 week was challenging for them to complete.*

PI: *Before we propose new stim recordings to patient let's please discuss internally and agree timeline/protocol.*

Ultimately, a decision was made to solicit the participant's input through the research coordinator, which could then be relayed to the rest of the research team, rather than through an informal group chat. In this instance, we learned that the most annoying task for the participant was the finger tapping task, however we continued to include finger tapping in our experiments. Ultimately, that relayed piece of feedback did not impact how researchers designed experiments.

By adhering to common practices of clinical research such as limiting interactions between participants and researchers, and not including participants in discussions about the research design or process, we missed opportunities to learn what the necessary conditions were for facilitating clear and effective communication. This in turn led to missed opportunities to learn about different contexts that impacted the participant, including their divergent abilities to perform tasks when symptoms are present, and their uncertainty for how to interpret our written instructions. Ultimately, by keeping the participant separate from our research and design processes, noise was added to some of the data that we collected.

Subtheme 2.2: Theory vs Reality of Participant Engagement in Research

No specific questions were asked regarding whether the participant engaged in knowledge discovery or creation. Certainly our project, in following general paradigms of traditional clinical research, was not designed for them to participate in the research process beyond their conducting experiments and providing direction for where to install the platform ecosystem. Regardless, throughout the interview as well as in various sources of field notes, I learned that the participant demonstrated engagement in many different ways. I developed this subtheme around the different ways that the participant demonstrated their engagement in the research process.

Engaging in knowledge creation: The participant demonstrated tangible engagement when creating the precisely timed experiment guide (Figure 4.3) described earlier. This lessened their mental overhead of needing to remember the timing for when to switch between tasks and body sides. It also reduced the chances that an experiment would need to be re-recorded in the event that some part of it was forgotten, which directly impacts time, resources and financial costs for research studies. This contribution ultimately highlights the need for such an experiment guide, which was not something researchers initially had conceived of in our design process.

The participant made a similar contribution in the early stages of the study regarding network security of the deployed platform. On the day of platform installation, the participant shared their preference for *utilizing a VPN for remote data collection*. This was not implemented in our initial platform designs. The participant recommended a state-of-the-art VPN protocol and shared sketches with researchers to aid in updating our platform design to better suit their security needs (Figure 4.4). Here, the participant actively contributed to the design process alongside the researchers.

Engaging in knowledge discovery through dialogue: Several insights were gained from talking with the participant, who readily engaged in discussions over the course of the interview. Perhaps the most surprising discovery was the previously mentioned ambiguity in the experiment protocol and its subsequent implications for our research outcomes. Prompted by this finding, I asked what other tasks or movements, free from the trade-offs in movement ability experienced during symptoms, might align with the participant's daily activities to help transition aDBS from controlled experiments to everyday life. The participant shared that they experience regular difficulties with balance:

weill7 VPN setup

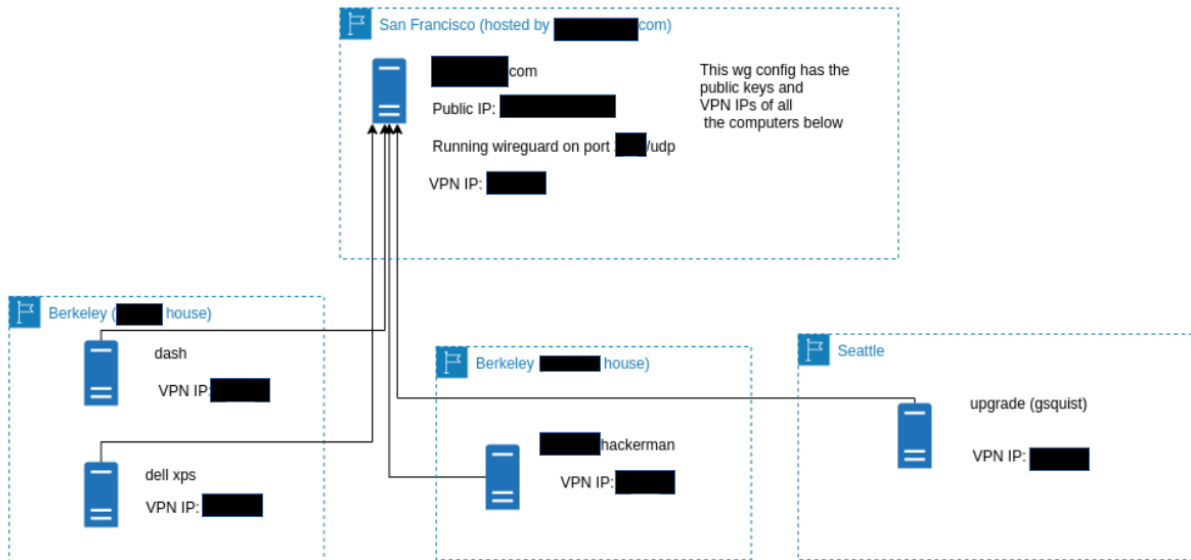

Figure 4.4: Participant-designed VPN Wireframe: During the initial installation of the platform ecosystem, the participant asked us to update our design to include a VPN to increase network security to better protect their privacy during remote data transfers. They suggested a state-of-the-art open-source VPN protocol and created a wireframe potential design showing data-flow. Researchers adapted this during later iterations to eventually arrive at the design shown in Figure 2.1.

Every time I go down the stairs...I'm grabbing walls and leaning on them. I wonder whether I just blanket that [wall] with cameras. Losing balance is a big deal [...] It's hard to picture an aDBS that figures out that I'm about to fall [...] in time to catch. What's funny is that if you got all my [stair climbing], one could predict when I'm going to lose it.

Building on this, the participant suggested an experiment to study their balance in a setup similar to something they experience in everyday life:

participant: *As an experiment, you could place kids toys around the room in a certain arrangement and have me walk through them. That'd be very realistic.*

researcher: *my dad would call them 'landmines': you come down the stairs in the morning, and you're groggy, and you don't see it, and you step on a lego.*

participant: *A lego test.*

In this conversation, the participant brainstormed an idea for building a prediction model for when they will lose their balance using video data, and an idea for an experiment that closely matched a routine experience in their everyday life.

Further, during the discussion about the participant's experience living with DBS and its accompanying technology, they described a circadian experience of becoming more slurred in their speech every evening:

Later in the day, I get quieter and quieter. Too quiet, or too slurred. I could usually fix it, if I focused a lot, but it's kind of everyday.

This contributed insights into a routine symptom that they experience and a future research direction that could be explored when trialing new aDBS algorithms. Their ability to correct this symptom if they focus suggests cortical changes from increased focus or attention as another potential biomarker [197; 198; 199].

Engaging through a sense of ownership and agency Another way I evaluated the participant's engagement is through their expressed sense of ownership and responsibility for the study and the research process. Throughout the interview, the participant frequently made statements framed with "I" or "we". To make this clear, I highlight in bold text the places in direct quotes where this framing occurred.

For example, when I asked the participant about their experience communicating with researchers during the interview, they recalled searching through their email when researchers emailed them multiple versions of an experiment protocol that required a correction or adjustment to be made:

*there were [...] multiple word doc versions sent in email, and it was hard to find the right one. There's the procedure, and [...] exceptions to the procedure, and remember those, and fold those in. **I think we could** have done better with a live document and edit, or **I could** put in notes of stuff that **I need** to remember. The old fashioned notion of write the protocol and give it to patient was sometimes limiting.*

Prompted by this memory, the participant shared they had wanted to make it easier for the researcher who needed to slice relevant portions of the data. To facilitate this, *they watched the clock on time.gov when starting an experiment to ensure each experiment block started precisely at the top of the half hour.* They added:

we, I, someone, certainly could have made...a really regulated timer.

Interestingly, I had noticed this precision of time deltas between each task in the experiments; however, since I did not know that it was intentionally implemented by the participant, I could not leverage it to expedite data processing.

When reviewing field notes, I found an occasion where the participant took the initiative to *adjust their approach to a typing task* for a newly begun experiment:

participant: *I also decided to fix all errors and make a good copy, which I didn't really do on the past round. So you should get legit backspace behavior.*

We again see this phrasing when we discussed the ambiguity in the written experiment protocol:

*...why didn't **I come up**, maybe if there was...a protocol debriefing meeting...all together and **I make sure** you've explained how many seconds you want between repetitions here...follow up on what's ambiguous in here. If someone had asked me, what's ambiguous in here, **I would** have spoke.*

When sharing their creation of the experiment guide, they state:

***I made** a thing about this!*

Even when describing an experience where an error was made during an aDBS experiment that the participant was not in control of, they expressed shared responsibility:

***We turned** it up too high.*

The participant demonstrates a strong sense of ownership in the process of research, a sense of collaboration with the researchers, taking initiative when creating the experiment guide, and adjusting how they performed a typing task. The participant took responsibility both for their actions and in describing an error they had no control over.

Engaging through questioning I further evaluate engagement through how often the participant conveyed curiosity about the purpose and value of research process activities. The participant frequently expressed that they had wondered how the research was going, if the things they were doing were useful, and the purpose of certain design decisions. This occurred so often throughout the interview that one researcher wrote reflection memos about it that later became part of our codes:

- *[participant] seems to be guessing as to study design points.*

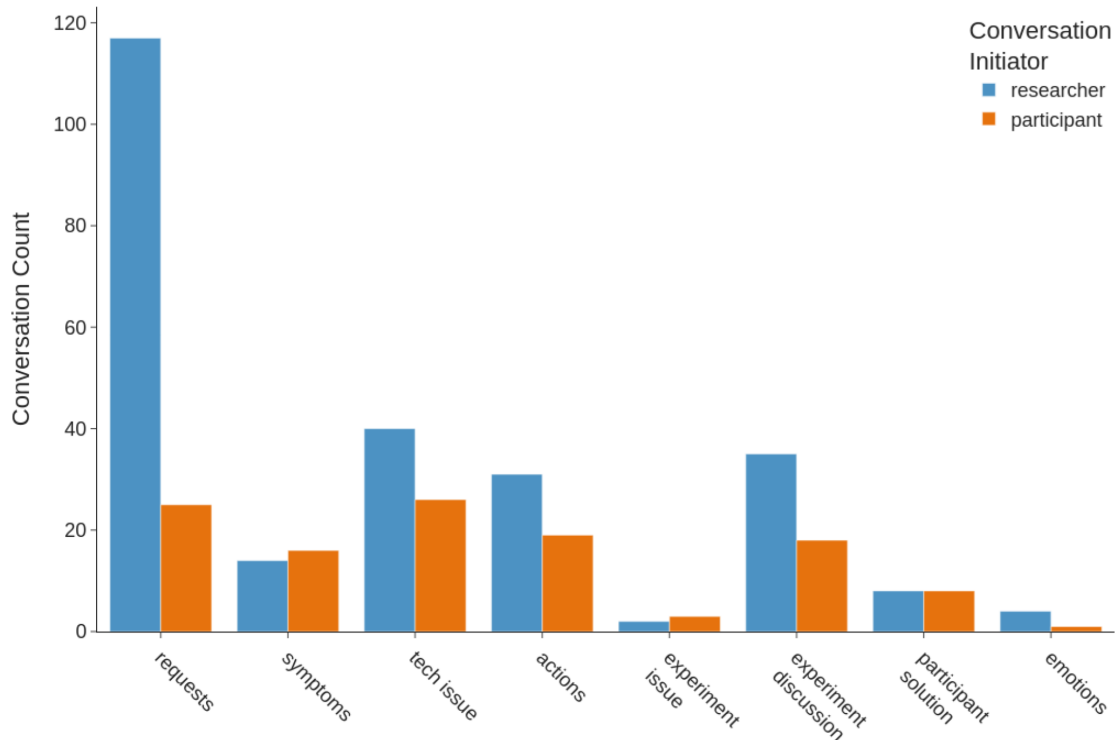

Figure 4.5: Topics of Conversation in G-Chat: Individual messages from 2 years of G-Chat activity between the participant and researchers were divided into discrete "conversations" based on whether the cosine-similarity of a message was less than 0.7 compared to the previous n -messages, and if a message was *either* sent more than 5 hours after the previous message (5 hours is the mean time gap between messages), *or* if a message started with a standard greeting that included the participant's name. Topics were identified by parsing keywords and phrases from text that I selected after manually reviewing the de-identified text data. Topics are only represented once per each conversation category in which they occur; however, a conversation is represented as many times as there were unique topics in it (e.g., a conversation on requests and tech issues would appear once in the requests bar and once in the tech issues bar). The predominant conversation topic was technical issues, the majority of which were initiated by researchers.

- *Humans will try to "play by the rules" – or, if co-designing, will help you achieve your stated goals.*

From contributing directly to research outcomes to expressing strong ownership, responsibility, and curiosity about the research, as well as readily engaging in brainstorming future experiment ideas and offering insights into aDBS feedback signals, the participant was exceptionally engaged in many aspects of the research process, despite the project not being intentionally structured to facilitate this.

Subtheme 2.3: In-house tech support required

The final subtheme reflects the need for someone in the home to engage in tech support. In various ways, in-person tech support was needed frequently throughout the study, particularly for the smart watches and the application that streamed watch data. The most common conversation starter in G-Chat focused on requests by researchers asking the participant to do something, and the second-most common focused on technical issues (Figure 4.5). Technical issues included restarting smart watches, unpairing and re-pairing devices connected to Bluetooth, replugging a loosened ethernet cable, etc. Short of a researcher visiting a participant's home every time a technical issue occurs, such actions will fall to someone living in the home. That was certainly the case in our study, where the participant actively and personally engaged in various kinds of in-home tech support.

Interestingly, I encountered the following statement from a researcher to the participant in G-Chat about one year into the study:

You aren't expected to help us troubleshoot anything but please let me know if it gets stuck again.

While this sentiment certainly adheres to the traditional model of a clinical study, it differed greatly from the reality of our study.

4.4.3 Theme 3: The effects of When, Where and How on What gets communicated

There are many ways that the contexts of communication influenced what was communicated, and ultimately created different effects in our project.

Subtheme 3.1: Insights from Chipotle: context and conditions for effective communication

In field notes, a researcher shared this experience with the participant:

I had a serendipitous encounter at Chipotle last night... Ran into [the] participant...who had grabbed my burrito from the pickup shelf. Got to chat with them for a while outside the tumult of a child-filled home and had a really good conversation. I made everything clear about what we are hoping to collect in the near term, and learned that their concern has been primarily over the long days spent in group A (though the active experiments also take a bit of a toll). They were very receptive...and said that they would collect the move-aDBS dataset ASAP.

Similar to the conditions for when I learned about the ambiguity in the experimental protocol, researchers learned about some of the participant's concerns regarding different types of recordings for data collection when conversing in person and when the participant's children were not present. In these examples, there is a pattern where relevant insights arise under certain conditions, such as during uninterrupted time or through a face-to-face communication medium.

Subtheme 3.2: Researcher uncertainty regarding how to communicate with the participant

In Slack field notes, some researchers expressed uncertainty regarding how to communicate with the participant at various points. They expressed concern that they might cause the participant annoyance or a feeling of being burdened if they communicated or requested assistance too often. I expressed this the most frequently in field notes, partly because I had the most interactions with the participant apart from the UCSF-affiliated researchers.

In a discussion about the difficulty of implementing 3D pose, one researcher relayed that the participant offered to help with the code. Another researcher responded:

That's awesome. I thought about suggesting this, but felt like it might be overstepping to ask them.

A third researcher added:

I've never met the participant and have no idea how the dynamic feels. I feel quite embarrassed to let the participant help with our work

Halfway through the study when UW obtained IRB approval for direct interaction with the participant, I made a request to one of the researchers to try to remedy my own sense of uncertainty:

maybe you and [research coordinator] can briefly share any "guiding principles" we should keep in mind when interacting with the participant, now that we have that part of the IRB taken care of?

In the field notes from early deployments, I mention:

I worry that if I'm [...] restarting the app or whatever, it will weird them out potentially (should they notice it affecting the monitor or something).

At other times, I conveyed a sense of hesitation through the following phrases:

This is the first project where I've ever even slightly interacted with a participant so I'm still tip-toeing around so to speak.

So excited/nervous to have the participant join us for the retreat, what an awesome idea.

Do you think I should start emailing the participant directly? IRB-wise I know that its ok now, but I just wondered if that would be helpful or more confusing

to have too many points of contact?

Do you think sending text on a separate page for each day is good, or too annoying maybe...

In this subtheme, I highlight a few factors effecting communication. First, having never worked with human participants before, or having never spoken to this particular participant, researchers experienced uncertainty about interaction dynamics with the participant. Second, researchers experienced uncertainty about what is appropriate to ask of participants, such as the idea of the participant working on problems assigned to the research team. Discomfort at this idea was expressed, which is not surprising since it is far from standard for a participant to take an active role in the research process. Concern was also expressed about disturbing the participant with unexpected activity from researchers working remotely at unusual times of the day on devices in the participant's home. Notably, the UW-affiliated researchers did not have any direct access to the participant until halfway through the study. This sudden change was unaccompanied by any formal guidance on how to navigate this adjustment. Though all researchers who conduct research involving humans are required to take basic training, content is limited to topics surrounding informed consent and privacy for protected health information.

Nowhere throughout the field notes did anyone suggest asking the participant about their communication preferences. In hindsight, this seems a simple solution to reduce uncertainty regarding preferred communication practices.

4.4.4 Theme 4: Who is the Person in Personalized Medicine?

I developed this theme to address the consequences of the participant not having a clearly determined role in our research study and instead assuming unofficial roles.

Subtheme 4.1: Needs, preferences and treatment priorities

I developed this subtheme around the role of a stakeholder or end-user. While there is no formal definition for a stakeholder, in clinical research or otherwise, generally stakeholders are people who have something to gain from the research that is being done, or have some "stake in the game". Exactly what it is that

stakeholders need, prefer or prioritize is generally what informs the requirements of a research study. Thus, it is important to know precisely what stakeholders' needs or goals are when designing a study. During the interview and in reviewing field notes, I encountered some of the participant's needs, preferences, and priorities for treatment that were unidentified, misidentified, or else identified but not pursued during the course of the study.

Treatment priorities:

A researcher priority was capturing the bradykinesia symptom by measuring the participant's speed and velocity during experimental tasks. We focused on this symptom since it is one of the cardinal symptoms experienced by many people with PD. It was also an appropriate choice because the participant in our study experiences bradykinesia when their stimulation amplitude is too low, and when their stimulation is set to their preferred amplitude this symptom is reasonably well-treated. This was not the case with their symptoms related to balance, as I discovered. While the participant reported falls a couple of times in G-Chat, it was not until the exit interview that I learned more about how balance issues were a "big deal" for this participant. While treating balance issues from PD was not in-scope for our project, future at-home aDBS studies may find contextual relevance in learning what the main concerns of participants are.

Preferences:

During the interview, I learned about the participant's communication preference for using G-Chat rather than email for ad-hoc communications with researchers. While the research coordinator frequently communicated with the participant through G-Chat, email was also regularly used such as when sending the participant experiment protocols, or when communicating during the platform installation. The participant also shared their preference for receiving their experiment protocols:

I think we could have done better with a live document and edit, or I could put in notes of stuff that I need to remember to do. The old fashioned notion of write the protocol and give it to patient was sometimes limiting.

In reviewing field notes, I also learned that the participant always recorded the time they took their medication on their phone but not always in the smart watch application or other digital portals that researchers

could access. The participant already had their own system using their personal phone that they preferred to use.

Later in field notes, researchers relayed that the participant requested an update to the camera recording application to enable them to directly adjust the video recording schedule, rather than having researchers update this whenever the participant relayed their needed scheduling updates. While this was an initial goal of our research plan, it was not prioritized and ultimately it was not implemented during the course of the study.

Needs:

We discovered the need for a timed experiment guide only by the participant creating one. Since this was an unidentified need, addressing it was not a part of the research agenda.

In various ways, the needs and preferences of the participant were sometimes unknown, misunderstood, or simply took a backseat to other priorities.

Subtheme 4.2: An adaptive "normal": The Missing Expert in receiving DBS, living with PD, and being a person in "Personalized Medicine"

Throughout both portions of the interview, the participant shared aspects of their life that are now a "normal" occurrence from living with PD and receiving DBS therapy. An example of this is their daily experience of speech changes at night. While this can usually be corrected if the participant intentionally focuses on it, their note that they become quieter suggests that the focus required to overcome it is sufficiently difficult such that they sometimes choose not to.

Another routine occurrence is the approximate 2-hour period of down time while the participant is recharging one of their INS batteries, which occurs every 1-2 weeks. Their strategy to let their body alert them to the need to charge the INS battery by becoming half frozen is itself an experience that someone not living with PD or DBS therapy would experience.

DBS sensations are also a regular experience. When discussing their method for knowing when to charge their INS batteries, they described the sensation, as well as the difficulty of articulating it:

participant: *when you go from a dead battery to recharged, there's just one side of the body tingles.*

researcher: *Something probably most folks haven't experienced.*

participant: *It's a little hard to explain. We need to finally give DBS to a poet to properly express what it's like.*

The participant's routine of catching themselves against the wall every time they go down the stairs is another "normal" part of their day-to-day experience.

There are a multitude of ways in which research outcomes could improve if the participant was viewed as an expert in the research process. For example, if we view them as an expert in living with a disability, or as experts in how they navigate their home space as a part of their daily routines, it would be reasonable to seek to learn from them *before* designing experiments for them to perform in their homes outside clinical observation. By proactively including their input, we can design experiments that better account for the unique trade-offs that they experience and thus be better able to interpret the data that we collect.

4.5 Discussion

In this user experience case study, I learned important context surrounding our prior work. I can also answer reviewer inquiries. In light of these results, I reflect on opportunities to improve future work in aDBS at-home translation.

4.5.1 On Complexity: It Gets Worse Before It Gets Better

Automating technologies to simplify their implementation can actually make things more complex, particularly when automation is still in development. Automating DBS is a new endeavor, as is translating aDBS to real-world settings, so I am not surprised to see the "it gets worse before it gets better" phenomenon occur. However, it is often unclear what constitutes "better."

In the example where the participant describes their method for managing the implanted INS battery life, I was surprised to learn that "it's not so bad to be frozen on half your body" and that, for this participant, it

was preferable to allow this sensation to alert them to the need to recharge the INS rather than preemptively monitoring battery life. Before having this conversation, I would have assumed otherwise on both counts and would have further assumed that the participant simply "needed" a "better" battery management system. While a battery management system could be built where the participant could simultaneously be freed from needing to actively monitor battery life *and* from experiencing sensations of being half frozen, it is also possible that they (or others) prefer a "physical" or "natural" alert system.

The point here is that we cannot know what the participant's needs are unless we ask. My assumption that the participant would prefer a proactive battery management system is an interesting example of the "technology push" and the "need pull" phenomena in engineering and technology fields, where a technology, however sophisticated, may not actually serve a person's needs, and thus is not utilized as intended or at all [200]. This also serves to highlight that for this participant, the priority was reducing the number of things they needed to keep track of. We see this again when the participant takes the time to build an office shelf to better organize and track the hardware components they need for data collection, including using velcro to physically keep components in place. We see it again when the participant takes the time to create an experiment guide that removes the burden of actively tracking when they need to switch tasks or body sides (Figure 4.3). In all of these examples, being able to "not think about it" reduces and simplifies the mental workload of managing their life and their care.

In moving technologies from research lab to real-world environments, an immense number of contextual factors need to be considered. One of these is the impact of having many people pass through the living space. In our case, having multiple people in view of video cameras created a pose-processing difficulty due to our choice of software. Towards the end of the study, we built software to resolve this. However, for the majority of the study, it was an unsolved problem. The participant often chose times of day to do experiments when they were less likely to have other family members passing through their office space, and they gamified an incentive for family keeping away from their office area when they were conducting experiments. This, of course, was less feasible on days when we did full-day naturalistic recordings.

Keeping these kinds of dynamics in mind is vital when selecting project tools. It would be prudent to ask participants if they anticipate or prefer having family pass through spaces where they are engaged in experiments, which can inform not just the tools that are chosen, but how to better align a system with the

participants' preferences to reduce friction points between participating in research and going about daily life.

4.5.2 Time for a Re-Match: Structuring At-Home aDBS Research

The Wall in the Tower

At the time of this writing, studies deploying remotely maintainable platform ecosystems to the home of a person with PD are still quite rare, and there are no established practices or specific regulations for how to carry out such work. For the portions of our study involving conducting experiments for data collection, we followed practices that are frequently adhered to in the majority of clinical research, such as excluding participants from actively participating in design processes with researchers [125; 156]. As discussed in the introduction, such research is dominated by positivist underpinnings.

The irony of having added noise to our data, the very thing positivism seeks to avoid at all costs, by following the positivist strategy of distancing researcher and research participant, is not lost on me. Should neurotechnology researchers continue this practice in their future research studies?

Clinical studies endeavoring to demonstrate a proof of concept, such as in our prior work, are occasionally referred to as *pilot studies* or *feasibility studies*. Pilot studies are considered an important preliminary step before an RCT can be safely or effectively deployed. Among other things, they help lay the groundwork for larger-scale treatment or intervention trials by assessing if the intervention is feasible and identifying the needs and requirements of a larger coordinated effort [201; 202].

Interestingly, guidelines on best practices for pilot studies⁴ note that pilot studies are *not* hypothesis testing studies. Thus:

"No inferential statistical tests should be proposed in a pilot study protocol. With no inferential statistical tests, a pilot study will not provide p-values." [202]

And again:

"Quite often the emphasis is wrongly placed on statistical significance, not on feasibility - which is the main focus of the pilot study." [201]

⁴These are best practices for general pilot studies, and do not necessarily refer to the type of in-home study that we conducted.

In traditional clinical (and indeed, in all STEM) research, *statistical significance* has become the holy grail method for demonstrating a major tenet of positivism: that we can reasonably support a claim of cause and effect. Overwhelmingly in literature, statistical significance is established by reporting the notorious p-value. To say that the p-value is considered the "paragon of virtue" for publications across all of STEM research today would hardly be an overstatement. This persists despite statisticians and scientists alike pointing out how the p-value is so often incorrectly interpreted and further begging researchers to consider other methods of demonstrating validity for a quarter of a century [203; 204; 205; 206; 207; 208; 209; 210; 211; 212].

Their pleas have largely been to no avail. Nuzzo writes:

"P values have always had critics. In their almost nine decades of existence, they have been likened to mosquitoes (annoying and impossible to swat away), the emperor's new clothes (fraught with obvious problems that everyone ignores) and the tool of a "sterile intellectual rake" who ravishes science but leaves it with no progeny. One researcher suggested rechristening the methodology "statistical hypothesis inference testing" [208], presumably for the acronym it would yield." [203]

Nuzzo continues:

"For all the P value's apparent precision, Fisher intended it to be just one part of a fluid, non-numerical process that blended data and background knowledge to lead to scientific conclusions. But it soon got swept into a movement to make evidence-based decision-making as rigorous and objective as possible." [203]

Our own prior work includes such a p-value, despite its clear demarcation as a pilot study. Clearly, researchers today feel the need to include this statistical "stamp of legitimacy" in their work regardless of the need for it. I do not suggest that statistical testing has no merit in such studies; instead, I question whether the emphasis in clinical research is incorrectly placed [213]. One reason for excluding participants from engaging in research and design processes, and for limiting interactions between researchers and participants, is to try to minimize bias in collected data so researchers can generate reproducible statistics. And

yet, proof-of-concept studies are not only unlikely to be precisely replicable, but replicating their p-values is not the primary reason that such studies are conducted in the first place.

Following these traditional clinical research practices led to all experimental tasks being selected or designed and documented by the researchers, who in this case were all people not living with PD [18; 200]. We chose several tasks from the UPDRS as a way to compare novel methods for remotely assessing symptom severity to the in-clinic gold standard [55]. While I maintain that comparing any newly developed methods to current standard practice can be a useful comparison, we certainly did not need to write out *how* to perform these tasks without including and considering the perspectives of the participant. Furthermore, part of our prior work is motivated to improve upon the current coarse categorical system by developing new ways to assess symptoms. Developing continuous assessments of symptom severity and disease progression is an active area of research. Beyond the results of this chapter, the negative impacts of designing *for* someone *without* them is well established in literature [96; 214; 18]. Preserving the separation between researcher and research participant will only exacerbate these impacts, ultimately leading to a tangible barrier to neurotechnologists learning how to design technologies for people with divergent abilities [18; 200]. While there is published work in which such a separation is not emphasized, the majority of this work remains outside of the places where "mainstream" clinical research is disseminated. Is the existence of this separation solely due to a "field communication problem"?

From my literature searches, I suspect that research on the "other side" of the wall is not well understood [167] and ultimately, deemed not valuable. Certainly, if we see no value in what is behind the wall, why should we take the trouble to demolish it? Furthermore, if what is behind the wall actually poses a "threat" to our "objective" discoveries of "reality", we are likely to want to preserve this wall. Based on the work of this chapter, I believe (at a minimum) that investigating and reporting all important aspects for clinical pilot studies *within a single publication* is desperately needed. These aspects include including statistically measurable, non-numerically experienced, and contextually relevant components of studies. Unfortunately, I cannot state this based on an established body of prior literature since such work remains quite rare. I can only hope that the research community (including reviewers and editors⁵) will consider, based on this work and the work of others like it [92], that keeping "qualitative" methodologies at bay directly contributes to

⁵One way that editors could help in this area is by increasing the maximum length of papers permitted, since mixed-methods research or other papers involving qualitative work often require more space.

neurotechnologists *missing essential information* such as the context and lived experiences that are needed for translating their technology into people's lives and homes.

The At-Home Researcher

I have discussed at length the consequences for research outcomes when preserving the separation between researchers and research participants, and more generally when preserving separation between "quantitative" and "all other kinds" of research.

Traditional clinical research considers the role of a research participant as distinctly separate from that of the researcher. While our study generally followed this distinction, in practice this was often not what happened. In multiple ways, often without researchers being aware of it, the participant was exceedingly engaged in various aspects of the research process that are traditionally relegated to the role of researchers.

A vital component for any study is conceiving how it should be designed, and we spent several months prior to deployment designing our prototype platform ecosystem. On the day that we installed the platform, we encountered a previously unknown design requirement: the participant requested a VPN to be a part of our architecture to better ensure privacy and data security. We realized quickly that this was an excellent design idea, and it has continued to this day to be a streamlined and highly secure pillar of our entire ecosystem implementation. In this stage, the participant did not merely provide an update to our design requirements; they also offered solution ideas for implementing this requirement, sketched out wireframe diagrams to help researchers envision an updated architecture (Figure 4.4), and provided technical guidance upon actually implementing the open-source VPN protocol. Their engagement in this aspect of research was not only extremely valuable but was far and away beyond what is considered to be the "role of participants".

Of course, it is unlikely that most participants in clinical research will have such specifically relevant technical insights for a study. Then again, choosing to host and build in a VPN was not on our initial radar, so we would not have thought to ask about this even had we planned to co-design and co-implement our architecture with the participant. In other words, we will never know what kinds of expertise and added value that participants can contribute if we do not interact with them.

Similarly, the participant took the initiative to directly create materials that are advantageous for conducting experiments without mishaps (Figure 4.3). Creating this guide helped minimize the likelihood of

experiment reruns, which in turn conserves time, money, resources and everyone's patience during long stretches of data collection. Importantly, it also has the potential to alleviate the mental overhead of trying to remember all of this. The participant shared that conducting experiments was "surprisingly tiring". Finding ways to make this process less taxing is important for participants' well-being. It also makes it more likely that participants will have the necessary resources to sustain conducting experiments for longitudinal studies amidst the rest of their day-to-day life.

We have seen that the participant was actively engaged in research, and that they are in fact indispensable to the research itself. Given this, perhaps it is not a surprise that the participant also strongly expressed a strong sense of ownership, responsibility, and agency for this study. Notably, they count themselves among the research team, and note that the research model, which constrains them to the role of "patient", limits "our doing better". They capture this with such lucidity that I will simply re-share their words:

I think we could have done better with a live document and edit, or I could put in notes of stuff that I need to remember. The old fashioned notion of write the protocol and give it to patient was sometimes limiting.

There is a contradiction in how the participant was engaged *in* the research process, while simultaneously being kept *out* of the research process. They repeatedly questioned research progress and the rationale for design decisions, and they attempted to guess our research goals to be better able to support our efforts. Their phrasing of "*that was a choice I had to make, and I was never really sure what to do*" when referencing the ambiguity in the written experiment protocol suggests they experienced a state of perpetual puzzlement that was never solved, while simultaneously having to guess and "make a choice."

Though some mystery surrounding the goals of an experiment can sometimes be a useful strategy (e.g. during a RCT or when conducting blinded experiments) I found it notable that the participant seemed to want to help us achieve our research goals to the point that obfuscating our goals from them did not prevent them from trying to guess and strive to be as helpful as possible. In this case, it may be important for researchers to determine whether more "noise" would be introduced into their data by explaining the goal of the experiment versus not explaining and leaving participants to wonder and try to guess on their own.

Guessing or trying to be helpful could actually add more variance. The answers to this might very well depend on the participant and how curious and engaged they are in the first place.

In analyzing a single exit interview and field notes, I learned there are many ways the participant in our study was highly engaged, in both their interest in the research and through their active participation in discovering and creating new knowledge. Not only did I gain an incredible amount of insights from the participant, there are significant aspects to translating technologies into people's bodies and homes that we cannot hope to gain without engaging with participants. The chance to conduct this study where the participant is intentionally considered as an equal partner in the research process⁶ is a lost opportunity I only wish I could go back in time to experience. I am confident from this work, however, that future studies, not to mention the people these studies endeavor to support, stand to gain immense benefits by intentionally and proactively engaging those who living with neurological disorders and use DBS technology in their bodies and their homes [200; 214; 18; 12].

Current Limitations of Telehealth

The majority of conversations in G-Chat were initiated by researchers requesting something from the participant (Figure 4.5). The requests were varied, such as requesting a time to meet on video call or determining an experiment recording schedule. Many of these requests focused on some type of tech support, where the most frequent technical issue involved the smart watch system we used to capture inertial movements. The participant wore an Apple watch on each wrist, and each watch was connected to its own iPhone. Each iPhone had an application installed that was responsible for uploading recordings to remote cloud storage. At times, data was found missing, and the application had to be refreshed or re-installed. At other times, watches had to be unpaired and re-paired to their respective phones via Bluetooth. Several small incidents like this occurred when troubleshooting difficulties with retrieving smartwatch data. Currently, researchers cannot remotely login to Apple watches or iPhones, so it falls to someone who is physically present to manually refresh, re-connect or reboot various components for troubleshooting data uploads.

The PC responsible for video recordings could be remotely rebooted once its TPM chip was configured.

⁶By this, I do not mean that the participant would necessarily have the exact same roles and responsibilities as every other member on the team. After all, this is not the case for researchers either, all of whom held different roles and responsibilities during the project. I will expand on what this could look like in greater detail in the next chapter.

However, the USB connected webcams occasionally needed to be re-connected to the PC. At other times, the ethernet port was discovered to be knocked loose from the PC. This caused all videos to auto-upload over WiFi, which was too slow to handle uploading 14 hours of 4k video per day, causing some data corruption and data loss.

As device capabilities improve and more remote-login and troubleshooting capacity are enabled, I anticipate that some of this burden will be redirected to automated and remote methods for managing deployed ecosystems. However, as long as there are physical aspects to our systems, there will likely be occasional assistance required from a person who is physically present. In the case of our study, that person was the participant.

4.5.3 Considering Communication

Several interrelated aspects of communication should be considered in our study, including researcher-to-researcher and researcher-to-participant dynamics. In this work, I chose not to focus our analysis on researcher-to-researcher dynamics; however, some of these dynamics provide context to the overall project. The researchers lived in 3 separate geographical areas and were affiliated with 3 different universities, and were fortunate to all be living in the same time zone. We see such multi-institution collaborations frequently in research today, given the complexity of multidisciplinary research [215]. However, organizing a coordinated effort across 3 schools, even for a pilot study, is a significant undertaking in and of itself. Starting the project before all of the researchers had obtained data sharing agreements meant that the "telephone game" was a strategy we utilized for half the duration of the project, resulting in some communication delays and misunderstandings.

There was also little guidance on *how* communication between researchers and the participant should be handled. The general tone of guidance from PIs was to try to minimize burdening the participant by limiting communication to only what was strictly necessary. In hindsight, I recognize that this assumption that "less communication equates to less burden for the participant" may be incorrect, or else an incomplete picture of what would be most amenable. We cannot know unless we ask them. In a recent paper sharing lessons from computer networking, [216] describe relationships and the communication patterns between them as a type of infrastructure. They share their experiences where trust was built between people over

time, in part through regular and positive interactions. Researchers from the National Cancer Institute had similar findings, reporting that participants emphasized the importance of frequent communication among collaborators [217]. The participant in our study preferred G-Chat to email, found the email delivery of the experiment protocol limiting, and that a protocol debriefing meeting would have provided an opportunity to make sure they understood the protocol. At a minimum, time and effort should be allocated at the beginning of a project to understanding participants' preferences for communication dynamics, and revisiting this issue throughout the study would account for any changes they may need as time progresses.

Having a clear understanding of what people's roles are (whether researcher or participant) is also important to determine and communicate [165]. This can inform what is appropriate to ask for or to discuss, can help to set clear expectations, and help ensure unsustainable burdens aren't being placed on someone. Roles can evolve over the duration of a clinical study, and they certainly did in our case [165]. For example, I became the primary point of contact with the participant after some of the UCSF-affiliated researchers took other positions. Building in time for regular check-ins over the course of a study could help ensure that everyone understands their roles and has the proper support to fulfill them.

4.5.4 The Unseen Expert of Neurotechnology

I discussed how our study was generally modeled as traditional clinical study, such that the participant was not intended to fill the role of a researcher (even though in practice this was indeed one of the roles that they filled). Given that the participant in our study is a person living with PD, considering them strictly as a "subject in a research study" does not provide a coherent or useful representation of who they are, what their role(s) is in the context of the study, and *why* they have said role(s). In fact, viewing them merely as a "research subject" would be inappropriate, not just because we seek to translate an integrated system into their body and their living space, but more foundationally because the entire premise by which we justify making DBS therapy *adaptive* is by endeavoring to provide people with a *personalized* treatment, presumably for their specific benefit [200].

Framing adaptive DBS as personalized medicine has occurred throughout literature since its advent in 2006, reflected in phrases including "personalized medicine", "personalized treatment", "personalized healthcare", "precision medicine", "a more precise therapy", and "tailored treatment" [126; 218; 28; 133;

219; 220; 221]. The notion of personalized medicine predates DBS by many years, gaining particular traction in the 1980s with the advent of the Human Genome Project and highlighted by the journal *Personalized Medicine* launching in 2007 [222; 223; 224]. This was further established in 2015 when US President Obama allocated \$215 million dollars towards a "precision medicine initiative" to promote the development and use of genomic tools in health care [224]. In practice, these terms indicate more of a "stratified set" of treatments or interventions for subgroups of people rather than a truly person-specific treatment. Regardless, it has been used to rouse motivation and enthusiasm from funders, researchers and the general public by promising a "better" and less "cookie cutter" approach to human health problems. With advances in machine learning capabilities and the dawn of fully embedded, closed-loop algorithms, "precision medicine" has renewed possibility for more person-specific treatment than ever before.

With this in mind, a natural assumption might be that the participant is also a stakeholder in the research. In actuality, this is not necessarily the case. Using our prior work as an example, the official title of the project was "Automated Optimization of Adaptive DBS for Parkinson's Disease." A listed goal for the project's outcomes was to "reduce the burden on both clinicians and patients." We discussed in Chapters 2 and 3 how DBS suffers from a high burden on clinicians needing to manually identify stimulation parameters for each person, and that aDBS algorithms introduce still more parameters that must be carefully selected. While aDBS research exists to more precisely treat symptoms, our project goals were to introduce methods that could enable aDBS to more easily scale to more people. In other words, there are at least two possible stakeholders in our project: people who receive DBS therapy, and the clinicians who parameterize it. In theory, one does not necessarily exclude the other; depending on its goals, a study can have one or both kinds of stakeholder. In practice then, who was the stakeholder(s) for our project? Unfortunately, while goals for the project were frequently discussed after being set by PIs, the stakeholders were never explicitly identified. In reviewing the analysis of this chapter, however, we can try to infer if, and to what extent, the participant was a stakeholder in our work.

In looking at stakeholder priorities for treatment, I discussed how the target for our symptom assessments was aimed at capturing bradykinesia rather than balance issues. Targeting balance issues was not in the scope of this project, however we did include a sit-stand task in some of our experiment protocols. Future studies may want to consider what symptoms are a "big deal" for their participants when designing experiments for

participants to perform while at home.

Regarding stakeholder communication preferences, we sometimes used G-Chat (which the participant preferred over email) and sometimes not. We also did not provide protocol debrief meetings to give the participant a chance to make sure they understood our instructions. When reviewing stakeholder preferences for the integrated system, we de-prioritized the participant's request to update the video recording application interface in favor of other research goals. Regarding stakeholder preferences for data security, we adapted our original architecture to accommodate the participant's desire for a VPN and in the process strengthened the design of our overall ecosystem. In this sense, the participant's preferences as a stakeholder were prioritized and adopted. Considering stakeholder needs for conducting self-guided experiments while at home, we were not made aware of this need until after the participant had remedied it for himself.

Altogether, if the participant was a stakeholder in our study, then they were one of multiple, and that ultimately their priorities, needs, and preferences did not always shape the ways we conducted our research study. If the participant was not the (primary) stakeholder, and they were not (considered) a researcher, did they fill a role as an 'expert' to help inform how we conducted our research?

I developed subtheme 4.2 to link routine experiences the participant had to adjust to; these are experiences that someone not living with PD or a DBS system would likely experience. Diurnal periods of limited communication from slurred speech, catching oneself on the wall when coming down the stairs, and going from half frozen to feeling newly charged DBS sensations that need "a poet to properly express what it's like" are just some examples of this. These experiences affect how the participant communicates with their family, relates to others, navigates the space in their home, and ultimately influences the systems we deploy, the data we collect, and the interpretations we make in the science we produce. We missed learning from these experiences and considering them throughout our design and research processes across 2 years. In concluding my analysis, I recognize the participant was an expert in several domains that our research was contextualized in and intended to treat.

Some might counter that participant expertise is already *in* the literature from previous studies, or that participants' clinicians and neurologists who are a part of our research teams can sufficiently inform us about their needs, rendering direct communication with the participant unnecessary or a waste of time. To this, I re-counter how young the field still is, and that sufficient knowledge is very far from being known

thus far in literature [140]. I also offer the results of this case study for consideration as a counter-argument. From miscommunications and forgotten participant priorities due in part to the "telephone game" nature of our communication structures, to introducing noise in collected data from ambiguously written protocols *written by people who do not live with PD*, I have seen how much we could have benefited from directly and regularly consulting with the participant. Furthermore, designing *for* people rather than *with* them risks objectifying the people who participate in our studies. Sullivan et al warns:

"Assistive technology fields would not exist but for the perception that persons with disabilities lack sensory and motor functionality that must be improved, assisted, or restored. If these needs are imagined by researchers rather than informed by potential end users, researchers may unintentionally contribute to the objectification of persons with disabilities as persons to be 'fixed.'" [200]

It is possible some people who want to be research participants will not want to actively engage in the research process. It may even be possible to conceive of an aDBS study where the research participants are not the stakeholder. However, I believe it is *not* possible to define, design or execute "effective research" if we do not see the people who participate in our research studies as the domain Experts that they are. By "seeing", I mean actively recognizing them as such. When we actively see someone as an expert, we tend to consult with them, learn from them, and structure our processes based on these learnings to maximize the benefit that our work can provide. Given this, I have determined a more appropriate term than "participant" is Expert-Participant, until such a time when I can ask how the people who participate in our studies would like to be referred to.

4.6 Conclusions

Our results and eventual conclusions took an unexpected turn over the course of reviewing literature in the philosophy of science, traditional practices in clinical research, and participant engagement in the research process, as well as during our thematic analyses of our prior work using largely non-numeric types of data. I initially set out to report on the expert-participant's experience while engaging in our study, providing context to our prior results and insights for conducting future at-home aDBS research. I achieved this, and

then some. In particular, I discovered that despite following the traditional research practice where expert-participants aren't intended to engage in the research process, the expert-participant in our study was in fact highly involved in many facets of the research process. Often, they engaged without the researchers' awareness and subsequently they sometimes engaged without receiving explicit support for doing so. They frequently and creatively took initiative to simplify their life and to solve problems in support of their understanding of the research goals. Their demonstrably technical background was certainly valuable, and yet that was just one facet of their contributions to our work. Their expertise in multiple domains such as living with a DBS system implanted in their body, living with our deployed ecosystem inside their house, and conducting self-guided experiments in common family spaces provided rich context and insights for what is important for integrating neurotechnology into the everyday life of a person living with a progressive neurodegenerative disorder.

Importantly, by excluding the expert-participant from our research and design discussions and processes, we wrote experiment protocols that did not account for the trade-offs the expert-participant experiences when symptoms are present and noise was introduced into some of the data we collected. There are clear and extensive benefits that researchers stand to gain by learning from expert-participants. Just as clear are the costs that researchers, not to mention PwPD, can incur by blocking expert-participants from having access to research processes.

The amount I have learned from a single exit interview is so rich I cannot fit all of it into a single chapter. As researchers endeavoring to bring technology to real-world contexts for people to use in their everyday lives, we stand to gain immense knowledge, wisdom and benefit by recognizing that people living with PD, with devices implanted in their bodies, and with systems deployed in their homes as relevant domain experts for our research goals. Who in all of academia would advise ignoring the experts of a given field? And yet this is what I believe neurotechnologists risk if we do not recognize the expertise that expert-participants have.

4.7 Dear Quantitatively-Trained Students Researchers: Recommendations for Translational Neurotechnology Research

Over the past three years of designing, building and deploying a fully remote platform ecosystem into the home of a person with PD, as well as during the work for this chapter, I have identified several practices that can benefit future neurotechnology translation projects. These recommendations target graduate student practitioners who design and deploy neurotechnology systems into homes, regardless of their research paradigm. They are based on my conviction that the people who volunteer to participate in our neurotechnology research studies are experts in multiple domains, including living with a disability, living with a progressive neurodegenerative disorder, living with neurostimulator devices implanted in their body, living with our systems deployed to their homes, and conducting experiments and research-related activities while being outside clinical observation and within their living spaces. I first provide the recommendations as a condensed list; this is the TL;DR version. I then briefly share my background to contextualize my recommendations. Finally, I expound on the condensed list to provide a more thorough description.

Recommendations for Students Researching Neurotechnology Translation

1. **Find a Mentor:** Identify someone who can guide you in working with expert-participants. This can be an unofficial mentor outside your official advisor. Professors outside your department, authors of interesting papers, or speakers at seminars are all potential supporters.
2. **Define the Roles:** Ask for the roles of everyone (including the expert-participants) involved to be explicitly defined. If the PI(s) does not know, your asking will help them find out.
3. **Field Notes for Context and Learning:** Get into the habit of taking field notes, which are a data modality similar to journal entries to capture dynamic events and the context in which they occurred. Record during, or immediately following, any events that occur, no matter how trivial the events may seem. You will want this information later during analysis. Regularly review field notes to consider what patterns emerge, and what changes you can make to better direct your work.
4. **Communication Set-up:** As early as possible, ask the expert-participant how they would like to communicate, including frequency and format. Ask them what kinds of communication they would

like to have. *NOTE: The following recommendations depend on these answers.* Re-state what you hear from them to ensure you understood correctly. Finally, re-ask this question regularly since needs will change over time.

5. **Re-Define the Problem:** Begin with a problem you think you want to solve. Set it to the side. Then, ask the expert-participant what problems they would like to solve. Compare this to the problem you initially identified. Together, formulate the problem(s) to solve. As before, re-state what you heard from/with the expert-participant, and re-visit this step regularly.
6. **Problem-Pose the Solution:** Considering potential solutions to a problem. Ask yourself "What impacts might this solution have on the system software, system hardware, system usability? Do any of these impacts pose a new problem?" Re-ask these questions with the expert-participant. Together, converge on solution(s) you want to implement. As before, re-state what you heard from/with the expert-participant, and re-visit this step regularly.
7. **The Moving Target of Research Goals:** The aims of a project are rarely set in stone. Be on the lookout for possibilities to adjust or refine aims based on your learnings from the expert-participants.
8. **On Transparency:** Strive to be transparent with expert-participants in all things. For example, let them know if their needs or priorities are not the main priorities of the people managing the project. This creates opportunity for them to make a more informed decision on how engaged they want to be based on the project's structure.
9. **Publish in One Place:** Strive to document your work holistically, where context and non-numerical information are included alongside any quantitative approaches rather than in separate journals or conferences.

4.7.1 Personal Research Background

In pursuing first a Bachelor's degree, and then a PhD in Computer Science, I learned how to do research informally, by watching others and replicating their ways of learning and running experiments. I found

myself wishing for a better understanding of why and how we can best conduct research, and took a research methods class. Ultimately, this class taught me little, so I sojourned on by learning as I went. At the start of the Weill Neurohub project, I scoured the internet looking for examples of the type of platform ecosystem we wanted to build. I queried the fields of cyber physical systems, video recording systems, wearable sensors and kinematics, computer vision and motion tracking, and home-based healthcare systems. I remember finding 2 papers that outlined a similar type of platform to what we were envisioning, both with $n=0$ (i.e. entirely theoretical). So, I pulled fragments from my literature searches with any insights I thought would be helpful. Nowhere in these places did I find anyone discussing how the people we build the systems for are uniquely expert in the problems we wanted to solve, or even mention their experiences of the technologies built for their use. Inundated as I was by many steep learning curves, and never seeing or hearing anyone in my research labs or the papers I read discuss these experts, it honestly and most unfortunately did not cross my mind. Towards the end of my program, I took a class called Computing for Social Good. This exposed me to many new areas of research, including different ways and rationales for how and why we can do research. It was around this time that I received the feedback from our anonymous reviewers. Between their comments and the contents of the class, I realized something incredible – neurotechnologists were starting to translate novel and cutting edge systems to the real world, and they were doing it seemingly without talking to the experts in living with the problems they endeavored to solve. More incredibly, no one seemed to be talking about it. A year or so later, and I've since learned that people are indeed talking about it – just not in the places where neurotechnologists typically publish their work. So while I hope no other students will repeat my mistake of missing the Experts in living with the problems we endeavor to solve, or better still that their research labs will have a culture of recognizing their research participants as Experts, I don't want to leave it up to chance. If this dissertation finds its way into your hands, here are some of the things that I wish I knew when I started this work some 3 years ago.

4.7.2 Student Recommendations for Translational Neurotechnology Research

1. **Find Support:** No matter what you try to do as a graduate student, having support from other researchers, particularly advisors, professors, and others with more experience is immensely beneficial for your success. If no one you work with or are advised by is interested in co-solving neurotech-

nology problems with the expert-participants, try to find someone who is. It is very common to have "informal" academic advisors who are interested in helping students that they don't officially advise. Sometimes these relationships later become fruitful research collaborations, but regardless people are often very happy to help students in their endeavors. Be creative and explore many departments outside of your own, such as Human-Centered Design and Engineering, Statistics, or Data Science facilities. Talk to the authors of interesting papers that you read, or speakers at a seminar or conference. If they are not able to advise you, they may know someone who can.

2. **Know the Roles:** Ask the project lead to explicitly define the roles of everyone involved (including the expert-participants). If they do not know, your raising the question can help them determine this. As the project evolves, you may find that different people take on responsibilities that were not initially a part of their role. You may also find yourself better suited to certain things than you originally thought. This is all part of carrying out a large team-based project; things rarely go exactly according to plan. Additionally, there are often ways to proactively adjust or refine someone's role. For example, if a research coordinator has been appointed the go-between communicator between researchers and expert-participants, you can still keep channels open by co-meeting with participants on at least some occasions as an opportunity to learn from them.
3. **Field Notes: The Unsung Hero of Data Modalities** Documenting work in academia is about as varied as are the ways that people conduct their research. I have found along the way how valuable is to log everything that I do, try, or think about in extreme detail. More recently, I discovered field notes.

- (a) **Capturing Experiences:** Field notes are a type of data modality common to many fields including Ecology and Ethnography. While they might seem similar to research logs, they are often more like journal entries. They can comprise a single sentence, or a full story of a class you taught, or an experiment you ran. It can describe what emotions you experienced or what body language you noticed while interviewing a Expert-Participant. In short, field notes are a way to capture and tell stories about dynamic events that occur. They are a powerful tool for providing the context in which things occur, such as how, at what time, in what temperature, in which location, involving

who, etc. This is particularly useful for translating technologies between domains like research lab to home. Because field notes are subject to the writer's perceptions and memories, it's a good idea to take them either during or immediately after the event you want to record. These can be informal, and they can all look different from each other. If in doubt about whether it's worth writing about something, write it down.

(b) **Regularly Review these Experiences:** Not only are field notes a rich source of analysis to share findings with others, iteratively reviewing them is a valuable way to study and problem-pose your current research process, which can enable you to make practical changes to improve your work before it is done. If that sounds like extra work you don't have time for, that's what [225]'s research participants said too. [225] describes methods for reviewing field notes that she devised together with participants during various participatory action research (PAR) projects to make this task quicker and less daunting. They found the insights they gained provided valuable lessons. For example, they discovered how their weekly meetings were being wasted from certain unhelpful communication styles, and that some participants were actively participating while others were not. Long-term, regularly reviewing field notes can save a lot of time and resources by helping you pivot to more helpful practices or methods while in the midst of a project.

4. **Communication Set-up:** There will be various rules and policies in place that somewhat determine the types of interactions you are allowed to have with expert-participants. Within those rules, at the earliest opportunity, seek a meeting with the expert-participants and ask them how they would like to communicate with you. This can include questions about frequency and format (e.g. video call, meeting in-person, etc). Ask them what types of communication they are interested in having. Would they like updates on research progress? Would they like to participate in the research process? If so, in what ways? Do they want to be involved in defining the research problems, solutions and agendas? Regardless of the answers you get, plan to re-visit this question multiple times throughout the course of your work. At the best of times, miscommunications will happen. It is always a good idea to follow up and to re-state what you think they meant, to make sure that you got it right. And even if you did get it right, their answer may (and likely will) change over time. This will also help you

learn if their communication needs are actually being met. Of course, these are all questions that your fellow researchers and advisors will likely have opinions on, including valid concerns about ethical practices. Again, finding someone to advise you in working with expert-participants will help you navigate these dynamics to find a solution that works for your situation.

5. **On Problem Solving:**

- (a) **Re-Find the Problem:** Scientists, maybe especially Computer Scientists, love solving problems. This is a wonderful thing. It can also make it easy to forget that before we can solve the problem, we need to know what the problem actually is. To do this, we have to ask the expert-participants. What's more, we need to ask them repeatedly. Again, follow up and re-state what you think they meant, and follow up iteratively to ensure their answers from before are still relevant.
- (b) **Problem-Pose the Solution:** Once you have an idea of what a problem is, you can come up with some solutions. Before you dive into implementing them, take the newly formed solution and ask yourself: what new problems might the solution pose? What are some potential impacts of implementing your solution? Would any of those impacts pose their own problems? Finally, talk to the expert-participant, and ask these same questions out loud with them. As before, get into the habit of doing this iteratively.

6. **Clinical Research Goals are a Moving Target:** If a project begins before expert-participants have even volunteered to be apart of the study, it can be difficult to conceive of how they can be consulted for defining your problems and determining solutions if research agendas are already established. Furthermore, your research colleagues may not recognize the expert-participants as experts, or they may not be comfortable with interacting with them or consulting with them. While these factors can certainly make learning from and working with expert-participants more difficult, and is not impossible. The aims or goals of a project, particularly with longitudinal studies, are not set in stone no matter how concretely they might be presented. They are, in a word, goals; an idea of what we may hope to accomplish. In practice, things will change, fall through, come together, not work out, surprise you, etc. All of this is to say that there are always possibilities for adjusting, refining or adding to research goals. Certainly, there are almost always multiple ways for exactly how to accomplish any single

goal. Some of these choices will be more conducive to addressing the expert-participant's priorities than others. Be on the lookout for those.

7. **On Transparency:** A frequent concern I have heard when discussing possible ways to learn from and co-research with expert-participants is that we may offer false hope that the expert-participant has power to impact the research when ultimately the PI or funders have final authority. Similarly, there is concern around managing expectations [226]. These are complex and important topics with a lot of nuance beyond the scope of this chapter. I will offer this, however: be transparent with the expert-participants. If they do not have equal say in a research project's directions, then be upfront about this (often students themselves do not have equal say, so this is a place you can perhaps find common ground). Be honest about what you know, what you think you can achieve together, and what your limitations are. Expert-participants can then make more informed decisions.
8. **Publish in One Place:** Strive to write up your work holistically, where context and non-numerical information is included alongside any quantitative approaches, rather than in separate journals or conferences. This is crucial for at least two reasons. First, as I have discussed in this chapter, neurotechnology research is highly multidisciplinary, and each aspect interacts with and effects the others. To only report on some of these inter-dependent aspects is to present a partial picture. Second, by presenting the complete picture, we will set an important example for establishing a "new normal" way of conducting and disseminating work that is situated in context and centered around the people who the work is intended for.

Chapter 5

Participatory Action Research for Responsibly Engineering Neurotechnology

5.1 Introduction

In light of our results in chapter 4, I discussed some of the consequences for clinical research when preserving its traditional distancing of researcher and research subject. We also discussed benefits for when this separation is not emphasized, as seen for example in Feldmann et al [92] intentionally engaging with research participants to learn from their expertise and subsequently adjusting their research processes based on these learnings. Participant engagement in the context of research is a very broad concept, and can mean anything from having a single conversation with a participant, to their actively engaging in the research itself alongside other participants and the researchers involved [227; 155; 228; 229]. There are examples in literature where participants are engaged in every aspect of the research process, starting with grant-writing and going all the way to publishing and disseminating the results with participants included as co-authors [180]. There has been extensive debate and significant concerns raised not only on whether this provides real benefit, but also on *how* this should be done. Debate and subsequent recommendations for navigating these concerns has been published by neuroethicists, however currently there is no single established "method" for doing so [141]. With uncertainty regarding ethical practices of collaborating with participants, not to mention the difficulty of introducing an entirely new set of perspectives and backgrounds into the complex

and non-stationary domain of neurotechnology research, it is hardly any wonder that the field is reluctant to attempt it. And yet, the benefits of doing so, and conversely the consequences for not, are evident from our results in chapter 4, and from the work of many others [167; 92]. I outlined strategies in chapter 4 to guide research students in learning from the expertise of participants and more closely aligning their research to participants' needs. However, it falls largely on researchers in positions of authority to ensure that this change actually occurs. How can we overcome our hesitation and all the ethical, technical and inter-personal challenges to actively engage with participants and more responsibly create and translate nanotechnologies?

Participatory action research (PAR) is a set of tenets for collaborative research that neurotechnologists could use as a flexible framework to help in this endeavor. PAR¹ is an approach for *how* to conduct collaborative research based on underlying principles that are unique, and sometimes counter, to traditional research [225; 226; 231]. Nonetheless, PAR has guided research in many different fields and contexts including the health sciences, networking, education, regional planning, and community development [230; 225; 216; 232; 233; 231; 234]. PAR is conducted by and within a specific community, yielding a resource-rich foundation that is valuable for sustaining complex initiatives like neurotechnology translation. Furthermore, a primary tenet of PAR is conducting research by or with the community, which structures research to be contextually relevant and to meet the community's actual needs. In this chapter, I describe PAR, explore the tensions between it and traditional research practices, and review an example from neuroscience literature demonstrating how PAR can facilitate fruitful collaborations between researchers positioned in traditional academia and a community that is positioned elsewhere. Finally, I draw guidance from the Community-Engaged Research with Community-Based Organizations resource manual from the Clinical and Translational Science Institute at the University of California, San Francisco (UCSF) to inform suggestions for researchers interested in structuring longitudinal aDBS or neurotechnology studies as PAR projects.

¹PAR is referenced by multiple terms, including Community Based Participatory Research (CBPR), action research (AR), practitioner research, action science, and cooperative inquiry [230; 229]. For simplicity, we use PAR throughout this chapter.

5.2 Tenets and Tensions of PAR

In fact, there is no single definition of what constitutes a PAR project. This is partly because PAR has originated from many different places, cultures and contexts around the world, including research to increase adult literacy in Columbia, improving adult and women's education in India, in improving agricultural training and technologies in Peru and Tanzania, improving water sanitation practices in Canada, and in advocating for rights of disabled people in the United States [225]. Because PAR projects are so diverse in their nature and context, and consequently diverse in their needs, different methodologies and paradigms are necessary and welcomed:

"[PAR] can incorporate multiple methods and welcomes the use of both qualitative and quantitative methods. The only methods not applicable to an [PAR] approach are those that distance the researchers from problems and questions of inquiry to ensure "objectivity" or avoid "contamination." [231]

This does require that PAR researchers are thoughtful about which models and methods they choose when designing their studies. [229] cautions:

"While a revolutionary thinker like Paulo Freire and a business guru like W. E. Deming may both have advocated a cycle of inquiry involving plan-act-observe-reflect, this does not mean that their two philosophies are epistemologically, methodologically, or ideologically compatible."

The philosophical underpinnings of PAR are also varied, and different thinkers emphasized different aspects. For example, Paulo Freire's *Pedagogy of the Oppressed* has been a particular influence on PAR, which was written on education for social change in the aftermath of the extreme poverty he and other Brazilians faced in his childhood [235]. Freire criticized researchers, humanitarians, and socialist revolutionaries alike for showing up on a community's doorstep with solutions to provide "relief" to their assumed "problems" before asking sufficient (or any) questions about their actual problems. Importantly, he insisted that *co-learning is a process that must be participated in by both the researchers and members of the community* in any endeavor to work alongside oppressed peoples. However, Freire is not the first to write about

PAR. Kurt Lewin was one of the earliest writers, after fleeing Nazi Germany in 1933 [236]. Lewin worked towards a program to help new immigrants to Palestine adjust to their new environment. Lewin particularly emphasized the need for action to be an integral part of the research process:

"No action without research; no research without action" [237].

Despite the differences across PAR projects, PAR has several tenets that invariably show up wherever it is practiced. A primary tenet is that research participants have control of the research process, and/or participate in designing the research process, which is something of the reverse of what we see in traditional research. While the degrees of control or participation varies across PAR projects, they are invariably conducted *by* or *with* individuals in a community, and never *on* or *to* them [229; 225; 226; 230].

Additionally, PAR projects are grounded in the context of the community that conducts them. PAR studies living systems, processes, or other dynamic phenomena within the community's natural or existing habitat. In this way, PAR is related to life sciences that study living beings from within their natural habitats or ecological contexts.

Another tenet of PAR is its cyclical and open-ended nature. PAR is typically characterized by cycles of "plan-act-observe-reflect" where knowledge and learnings from critical reflections on the actions that are observed are fed back into planning [231]. In this way, PAR has similarities to the design-develop-evaluate-analyze cycles of user-centered design, participatory design, and value sensitive design (VSD) [231; 238; 239; 240] and even to the iterative "agile" or "sprint" approaches frequently used in software engineering.

PAR is also characterized by seeking not only to generate new knowledge, but to create opportunities for personal and community growth, development, and empowerment [225; 229]. Knowledge generation and knowledge construction is an integral part of *how* PAR creates these opportunities, particularly through collaborative cycles of dialogue and critical reflection. [225] writes:

"It is by actively engaging in critical dialogue and collective reflection that the participants of PAR recognize that they have a stake in the overall project."

Because all people in PAR are participating, a unique outcome of PAR research is multi-directional learning

², where sharing of expertise is intended to be transferred in all directions.

PAR's cyclical structure, its emphasis on growth and empowerment of community, and its open-ended nature emphasize the *process* of research over the outcomes. These are defining characteristics of PAR that are not frequently a part of traditional research practices. Understandably, this makes traditional academic researchers, committees and IRB members stymied, suspicious, and concerned. [229] writes:

"IRBs are confused about risk factors in settings in which research subjects are participants in the research at the same time that they are, often, subordinates within the organizational settings. These power relations are further complicated when the action researcher is also an insider to the organization."

Confusion about where people should be "placed" can extend to the reverse condition, as *researchers are themselves participants* in their work [225; 229]. This becomes even more complex for clinical research endeavors involving neurotechnology which frequently are conducted by a diverse team of researchers, including researchers who are also clinicians. Clinician-researchers are researchers and part of participants' care team, which means they are positioned in multiple places and hold multiple roles simultaneously. Nonetheless, in PAR the knowledge of *all* participants is as valued as scientific knowledge, so everyone involved is a co-investigator, co-participant, and co-subject of the research process [231; 226]. Notably, this often means that there is mutual ownership of the products produced from research [12].

Beyond the inherent complexity of all collaborative work including in PAR, the context-specificity of PAR immediately provokes another concern in traditional research: the "generalizability" debate, where solutions that generalize are deemed the most estimable. As we discussed in chapter 4, "objectively" discovered knowledge from a positivist paradigm captures "true reality", thus it generalizes regardless of time passing or of changes to context [148]. From a positivist view, objective "truth" can be discovered by carefully following what is known as the "scientific method", where researchers endeavor to isolate independent variables in order to observe causal relationships. Adherence to the scientific method is sometimes referred to as "scientific rigor", and gives confidence in scientific outcomes because the results can (theoretically) be replicated by others. How are researchers to provide "scientific rigor" if they do not provide generalizability?

²we say multi-directional rather than bi-directional to note that collaborative community work may bring together several more groups of people beyond just "researchers" and "participants" (e.g. government officials)

An alternative to generalizability is the notion of "trustworthiness". [231] notes:

"trustworthiness is a valid and appropriate alternative to generalizability in scientific inquiry, [... stemming from] credibility, transferability, dependability, and confirmability."

Indeed, it is trust in the process of carrying out the scientific method that allows researchers to not have to start from ground zero each and every time, but rather to build on a trusted foundation of prior work. Similarly, PAR provides trust in the process in an alternative way to adhering solely to the scientific method.

5.3 Trustworthiness for Generalizability

To understand how PAR enables trustworthiness, I summarize [231]'s 4-point argument for how PAR achieves credibility, transferability, dependability, and confirmability, and reflect on its relevance to neurotechnology studies.

First, PAR is typically conducted in longer-term studies, which allows relationship building and learning what the community needs are. This longevity enables knowledge that is hidden, deep-seated, or protected within an individual or community (i.e. unlikely to be ascertained in a single interview or short-term study) to be discovered. In our retrospective analysis, we discovered pertinent information only through the "longer-term" discussion of the exit-interview. It is likely such discoveries would have continued if we had created more opportunities for longer discussions throughout the course of our study. Future longitudinal studies could build regular long-term discussions into their study design to facilitate this.

Second, PAR is context-centered, allowing researchers to make observations directly from the places or habitats where the community exists and where related phenomena naturally occurs. PAR also emphasizes the knowledge that comes from the participants themselves, such as from their explicitly spoken language and exact word choices. In this way, the knowledge and data garnered from PAR is "closer to the source" and increases credibility. This is important for studies on complex disorders like Parkinson's disease (PD) or neuropsychiatric disorders, which consists of a host of motor and/or non-motor symptoms that present in every person differently.

Third, PAR enables data credibility by including multiple perspectives, and by encouraging participants to critically reflect on data collected from or about them. During the exit interview described in 4, the partic-

ipant in our study recalled their uncertainty while doing experiments given the ambiguity of the experiment protocol. By creating opportunities for participants to critically reflect on research processes and outcomes, neurotechnologists can better ensure their data and results actually reflect what they think they do.

In [231]’s fourth point, PAR’s credibility can be measured by the “workability” of its proposed solutions, or how well solutions address real problems in the lives of participants. Because solutions must "work", theory and practice are inextricably linked; theoretical knowledge that is generated must be actively tried out in the field so it can be evaluated. Here, strategies such as user-centered design (UCD) can help neurotechnologists ensure workability of their solutions and thus establish credibility in their efforts.

In a way, PAR might be said to also seek generalizability, but only for the local context where the research is being conducted. An alternative word choice to generalizability is "transferability". [231] adds:

"the goal is instead transferability. To accomplish this goal, data must be collected, analyzed, and described as transparently as possible (dependability). Furthermore, enough evidence must be presented to confirm the events transpired as described (confirmability)."

For neurotechnologists, transferable could be used interchangeably with translatable. If we want to translate our technology from lab to the real world, it must be translatable, or workable, in the places we deploy to. Are we to conclude then that no outcomes of PAR are useful for anyone other than the community they are built for? Not necessarily. The trustworthiness that PAR offers, including dependability through it’s transparency, is such that knowledge or solutions that are generated can be thoroughly analyzed and understood by other researchers. This lets researchers determine what is similar and different in their context versus the context where the knowledge or solution was generated, to then determine what, if any, aspects can be replicated, adopted, or else changed. In short, PAR provides a framework for conducting research that is built on trustworthiness. Then, knowledge and solutions generated from this framework have the potential to translate to other contexts when and where appropriate [230; 241]. It is for this potential that [229] advocates for an increase in PAR dissertations:

"[PAR] dissertations contain a local perspective that few traditional researchers are able to provide. A dissertation forces [PAR] researchers to think not only about what knowledge they have generated that can be fed back into the setting (local knowledge), but also what knowledge they

have generated that is transferable to other settings (public knowledge)."

[47] pointed out that current translation timelines in neurotechnology are more similar to the pharmaceutical industry (slow) rather than technology in non-clinical industries (fast). Alongside recent efforts to help neurotechnologists speed up translation timelines such as open-sourcing our solutions (e.g. the Open-Mind Consortium [108]), PAR generates knowledge that is both relevant for its specific community and potentially transferable to other researchers [241].

5.4 A Worked Example of PAR for Clinical Neuroscience Research

In [12], La Scala et al describes their approach to neuroscience research as a PAR project for their developmental neuroscience study on mental health outcomes in preadolescent Latina youth. We chose to explore La Scala et al first because there are relatively few studies in clinical neuroscience research utilizing PAR, and second because La Scala et al did not start their study out intending it to be a PAR project, providing an example for how a research study can be re-structured partway through based on preliminary findings.

La Scala et al began with a focus on the neural bases of disruptive behavior disorder and conduct problems in Latina youth. This was motivated partly by accumulating evidence that lived experience impacts psychological processes [12; 76; 77; 14; 78; 79; 80; 81]. It was also based on their prior work demonstrating that they could not replicate previous findings to show reduced gray matter volumes in the anterior insula, amygdala, and frontal cortex in youth with conduct disorder symptoms. However they could replicate prior results showing reduced gray matter volumes in temporal regions, particularly in girls [242]. In a following study, they found that children with greater conduct disorder symptoms had a dampened hemodynamic response to viewing others being harmed in the insula, a neural region which plays a role in empathy and emotional awareness [243]. Sex differences in the neural correlates were again observed.

However, the focus of their study shifted after while informally speaking with families during data collection where they discovered that girls in their community were struggling with elevated panic and anxiety which were exacerbated by social stressors. They discovered evidence for Latina adolescents experience more internalizing symptoms and higher rates of untreated anxiety than their white, Black, and Latino peers, as well as influence of ethnic-racial value socialization practices among Latina mothers on children's emo-

tion expression, recognition, and regulation when they engaged in threat and safety learning. From there, La Scala et al re-evaluated the aims of their study and updated their research agenda to identifying families' concerns and centering their lived experiences.

The authors built rapport with community members through several strategic approaches to overcome structural barriers such as lack of transportation, need for childcare, and mistrust of the scientific community. A key strategy for their work was the use of a Community Advisory Board (CAB), facilitated by the first author who identifies as a Latina mother. During meetings, La Scala et al and members of the CAB collaborated on better strategies to recruit people in their community to participate in their study. They next developed an art therapy workshop series to connect with community members and provide children with tools to manage their stress through artistic expression. Workshops used art to explore emotions, and dance to provide non-verbal coping tools for anxiety using movement.

Their study certainly took a complete turn from its original intention of studying neural bases of conflict disorders in Latina children. Notably, after following strategies they developed to recruit people in their community, they experienced complete participant engagement and follow-through, even though the study took place during the height of Covid-19 lockdowns.

La Scala et al notes that re-forming their study as a PAR project required them to acquire additional funding. They also spent time revising their methodology, and building relationships with community members, including training their research team on how best practices for engaging with community members in collaborative research projects. They acknowledge that not all researchers would be able to accommodate these changes.

5.5 Recommendations for PAR in Neurotechnology Translation

The following are suggestions for researchers interested in PAR for neurotechnology translation research. They take inspiration from prior literature, including what was reviewed in this chapter, and from a researcher's resource manual for Recommendations from the Clinical and Translational Science Institute at UCSF [244].

5.5.1 Establish Community Relationships

The earlier you can begin to establish relationships with members or groups in a community, the more time you will have to develop trust and build a rapport. One of the most impactful aspects of PAR is that it researches and creates knowledge and solutions within a community. In this way, knowledge and expertise can be shared and new skillsets gained. Ultimately, co-researching and co-creating within a community offers the ability to tackle a much greater range of complexity and moving parts than a few people could do on their own [74]. This is already partially happening in projects where researchers include researcher-clinicians, who are members of the research community and members of the care team supporting people who have PD (PwPD). We can expand on this by more directly integrating perspectives from people living with PD, for example by including a CAB with PwPD as board members to support and work with the research team (e.g. advising on how to navigate co-researching with PwPD). Helpfully, conducting research where community partnerships are embedded in the research process has been found to maximize applicability of research findings to more people, as well as reducing costs[244; 12; 245].

5.5.2 Defining Roles

Depending on the type of research at hand, members in PAR almost always have a range of control in different parts of the research, and are assigned very different roles. In other words, co-design and co-research in PAR does not mean every person has the same job description. Thus, it's important to collectively decide what people's roles are and how efforts will be organized and directed. This will help to set realistic expectations. This is something that can be regularly revisited, especially for longitudinal studies as research outcomes and daily life create change.

5.5.3 On Transparency

A frequent concern mentioned in criticisms of participatory research is that power imbalances can promote a false promise of equality and end up exploiting people who don't have equal power or influence [246]. One way to help mitigate this is to be transparent about the constraints and requirements for a project. A toy example would be when someone undergoes brain surgery to be implanted with a DBS system. In that context, the neurosurgeon and medical team will appropriately have the power to make decisions. Not

every case will be so clear-cut, but engaging in dialogue built on established relationships can facilitate determining a healthy structure for the project.

5.5.4 On Communication

Both for establishing relationships, and for determining project organization, clear communication is essential. One concern we have heard voiced is that PwPD may struggle being in group dynamics with other PwPD that are at a more advanced stage of the illness trajectory [74]. These are important considerations, and holding individual conversations at the beginning of a study may help to identify similar areas of concern.

5.5.5 Collaborative Planning and Design

PAR is done by or with the members of a community. Thus, formulating research questions and study design cannot be done without them. Particularly when only some members are living with a disability, their input is essential for forming relevant questions and for designing lucrative research designs.

5.5.6 Research Implementation and Data Collection

PAR is not just about collaboratively formulating questions or opining on study design. Members of a community can also actively engage in the work of research itself. Investing in knowledge sharing will build capacity for everyone involved. This will also help community members to influence the choice of methods that are suited to their needs. Furthermore, involving community members in data analysis and interpretation can enrich the understanding and relevance of the findings, and can help catch mistakes or expose incorrect assumptions [247; 200].

5.5.7 Context

Regularly ask community members about their local context and lived experiences when interpreting results. This ensures that the findings are grounded in the realities of the community and are meaningful to them.

5.5.8 Sharing Results

Collaborate to find ways of disseminating results that are accessible and useful to community partners and stakeholders. This can include community presentations, reports, and other formats that are tailored to the audience.

5.5.9 Continuous Integration for Feedback

Establish habits to obtain regular feedback and evaluation. This helps to ensure that the research remains relevant and responsive to the needs of the community and allows for adjustments as necessary.

5.6 Conclusion

There are many ways to conceive of involving people in the research process; PAR is just one. While I see PAR as having great potential particularly for researchers in neurotechnology translation, it is not the only way. As long as a way is chosen to incorporate the perspectives, needs and expertise of the people we develop solutions for, we will immediately be better able to develop effective treatments and technologies that translate more quickly to the real-world. I call on principal investigators, funders, organization directors, and anyone with a position of authority in this space to cease researcher practices that miss the Experts in the problems they endeavor to solve. Choose *some* way of actively viewing and interacting with the participants in research studies as the experts that they are – there are many ways to do so.

Chapter 6

Conclusion

This dissertation is the result of nearly 4 years researching neural engineering challenges. In the first chapter, I share my open-source design for a platform ecosystem that can be installed in people's homes and maintained through remote access. The ecosystem is intended to support collecting multi-modal data from inside homes, and securely transferring this data to researchers for further analysis. The ecosystem includes a custom application that I wrote to automatically record videos based on a configurable schedule. Although this ecosystem was designed to support aDBS translation, it can also serve as an example template for ecosystems intended for other technology translation purposes. The first chapter also demonstrates how we collected data and verified its integrity. In the second chapter, I use the data I collected from smart watches and web-cams to develop continuous metrics that can assess different aspects of movement quality, as a proxy to remotely measure the severity of bradykinesia. In the third chapter, I design and conduct a post-study assessment of the participant's experience while engaging in our 2-year study. During this work, I learned many ways that the participant was engaged in various aspects of the research process, often unbeknownst to myself. I learned that if I design experiments for people who are living with Parkinson's disease *with* these same people, their experience can improve and my research outcomes can also improve. Ultimately, this analysis taught me that when I exclude the people who participate in research studies from research and design processes, I miss out on multiple areas of expertise that they uniquely hold which are highly integral to successfully conducting neurotechnology research. Their areas of expertise include knowledge about their unique set of symptoms and how those impact their abilities, their routines and their daily experiences.

It also includes their knowledge of living with a DBS system implanted in their body, and how this impacts their abilities, their routines and their daily experiences. They also hold expertise in their living spaces, including navigating performing experiments in common family spaces during different times of the day. In my work moving forward, I will now always strive to actively view the people that participate in research studies as inherently holding unique and valuable expertise that I will seek to learn from. Wherever they are willing, I will now always collaboratively engage with them in my research and design processes. Because research has limited resources, and because researching as a student entails limited agency, I created simple guidelines for student researchers to adopt if they are interested in co-researching and co-designing with expert-participants. These can be adopted or adapted to any situation, even for student's like myself who are primarily or solely trained in quantitative methods from post-positivist paradigms. Finally in chapter four, I introduce Participatory Action Research (PAR) for neurotechnologists to consider as a guide for how to collaboratively conduct clinical neurotechnology research with participants. PAR is a set of tenets that can guide participatory research, and is flexible and context-centered to be useful for a vast range of contexts. PAR is primarily conducted by or with the people who the research is intended for, helping to ensure research outcomes remain participant-centered. PAR is way of conducting collaborative research that I believe holds high potential value for neurotechnology translation. However, there are many other creative ways to conceive of collaborative research. Whichever way we choose to do it, it is my hope that neurotechnology researchers cease excluding participants from their research and design processes moving forward.

Bibliography

- [1] Steinmetz, J. D. *et al.* Global, regional, and national burden of disorders affecting the nervous system, 1990–2021: a systematic analysis for the Global Burden of Disease Study 2021. *The Lancet Neurology* **23**, 344–381, DOI: 10.1016/S1474-4422(24)00038-3 (2024). Publisher: Elsevier.
- [2] Organization, W. H. Parkinson disease: a public health approach: technical brief (2022).
- [3] Sjö Dahl Hammarlund, C., Westergren, A., Åström, I., Edberg, A.-K. & Hagell, P. The Impact of Living with Parkinson’s Disease: Balancing within a Web of Needs and Demands. *Parkinson’s Disease* **2018**, e4598651, DOI: 10.1155/2018/4598651 (2018). Publisher: Hindawi.
- [4] Jankovic, J. Parkinson’s disease: clinical features and diagnosis. *Journal of Neurology, Neurosurgery & Psychiatry* **79**, 368–376, DOI: 10.1136/jnnp.2007.131045 (2008).
- [5] Khobragade, N., Graupe, D. & Tuninetti, D. Towards fully automated closed-loop Deep Brain Stimulation in Parkinson’s disease patients: A LAMSTAR-based tremor predictor. In *2015 37th Annual International Conference of the IEEE Engineering in Medicine and Biology Society (EMBC)*, 2616–2619, DOI: 10.1109/EMBC.2015.7318928 (2015). ISSN: 1558-4615.
- [6] Intersectoral global action plan on epilepsy and other neurological disorders.
- [7] Henrich, J., Heine, S. J. & Norenzayan, A. Most people are not WEIRD. *Nature* **466**, 29–29, DOI: 10.1038/466029a (2010). Publisher: Nature Publishing Group.
- [8] Spates, K. “The Missing Link”: The Exclusion of Black Women in Psychological Research and the Implications for Black Women’s Mental Health. *Sage Open* **2**, 2158244012455179, DOI: 10.1177/2158244012455179 (2012). Publisher: SAGE Publications.

- [9] Gatzke-Kopp, L. M. Diversity and representation: Key issues for psychophysiological science. *Psychophysiology* **53**, 3–13, DOI: 10.1111/psyp.12566 (2016). [_eprint: https://onlinelibrary.wiley.com/doi/pdf/10.1111/psyp.12566](https://onlinelibrary.wiley.com/doi/pdf/10.1111/psyp.12566).
- [10] Jones, L. M. *et al.* Exploring Representation of Diverse Samples in fMRI Studies Conducted in Patients With Cardiac-Related Chronic Illness: A Focused Systematic Review. *Frontiers in Human Neuroscience* **14**, DOI: 10.3389/fnhum.2020.00108 (2020). Publisher: Frontiers.
- [11] Goldfarb, M. G. & Brown, D. R. Diversifying participation: The rarity of reporting racial demographics in neuroimaging research. *NeuroImage* **254**, 119122, DOI: 10.1016/j.neuroimage.2022.119122 (2022).
- [12] La Scala, S., Mullins, J. L., Firat, R. B., Board, E. L. R. C. A. & Michalska, K. J. Equity, diversity, and inclusion in developmental neuroscience: Practical lessons from community-based participatory research. *Frontiers in Integrative Neuroscience* **16**, DOI: 10.3389/fnint.2022.1007249 (2023). Publisher: Frontiers.
- [13] Martínez, K. G., Franco-Chaves, J. A., Milad, M. R. & Quirk, G. J. Ethnic Differences in Physiological Responses to Fear Conditioned Stimuli. *PLoS ONE* **9**, e114977, DOI: 10.1371/journal.pone.0114977 (2014).
- [14] Harnett, N. G. *et al.* Negative life experiences contribute to racial differences in the neural response to threat. *NeuroImage* **202**, 116086, DOI: 10.1016/j.neuroimage.2019.116086 (2019).
- [15] Slopen, N. *et al.* Racial Disparities in Child Adversity in the U.S.: Interactions With Family Immigration History and Income. *American Journal of Preventive Medicine* **50**, 47–56, DOI: 10.1016/j.amepre.2015.06.013 (2016). Publisher: Elsevier.
- [16] THOMPSON, C. Black Women, Beauty, and Hair as a Matter of Being. *Women's Studies* **38**, 831–856, DOI: 10.1080/00497870903238463 (2009). Publisher: Routledge [_eprint: https://doi.org/10.1080/00497870903238463](https://doi.org/10.1080/00497870903238463).
- [17] Etienne, A. *et al.* Novel Electrodes for Reliable EEG Recordings on Coarse and Curly Hair. In

- 2020 42nd Annual International Conference of the IEEE Engineering in Medicine & Biology Society (EMBC), 6151–6154, DOI: 10.1109/EMBC44109.2020.9176067 (2020). ISSN: 2694-0604.
- [18] Xiao, L. *et al.* A Systematic Review of Ability-diverse Collaboration through Ability-based Lens in HCI. In *Proceedings of the CHI Conference on Human Factors in Computing Systems*, CHI '24, 1–21, DOI: 10.1145/3613904.3641930 (Association for Computing Machinery, New York, NY, USA, 2024).
- [19] Webb, E. K., Etter, J. A. & Kwasa, J. A. Addressing racial and phenotypic bias in human neuroscience methods. *Nature Neuroscience* **25**, 410–414, DOI: 10.1038/s41593-022-01046-0 (2022). Publisher: Nature Publishing Group.
- [20] Lanciego, J. L., Luquin, N. & Obeso, J. A. Functional Neuroanatomy of the Basal Ganglia. *Cold Spring Harbor Perspectives in Medicine* **2**, a009621, DOI: 10.1101/cshperspect.a009621 (2012).
- [21] Wilkins, K. B. *et al.* Bradykinesia and Its Progression Are Related to Interhemispheric Beta Coherence. *Annals of Neurology* **93**, 1029–1039, DOI: 10.1002/ana.26605 (2023). [_eprint: https://onlinelibrary.wiley.com/doi/pdf/10.1002/ana.26605](https://onlinelibrary.wiley.com/doi/pdf/10.1002/ana.26605).
- [22] Griffiths, R. *et al.* Automated Assessment of Bradykinesia and Dyskinesia in Parkinson's Disease. *Journal of Parkinson's disease* **2**, 47–55, DOI: 10.3233/JPD-2012-11071 (2012).
- [23] Herrington, T. M., Cheng, J. J. & Eskandar, E. N. Mechanisms of deep brain stimulation. *Journal of Neurophysiology* **115**, 19–38, DOI: 10.1152/jn.00281.2015 (2016). Publisher: American Physiological Society.
- [24] Gardner, J. A history of deep brain stimulation: Technological innovation and the role of clinical assessment tools. *Social Studies of Science* **43**, 707–728, DOI: 10.1177/0306312713483678 (2013).
- [25] Tierney, T. S. Deep brain stimulation foundations and future trends. *Frontiers in Bioscience* **23**, 162–182, DOI: 10.2741/4586 (2018).
- [26] Mohammed, A., Bayford, R. & Demosthenous, A. Toward adaptive deep brain stimulation in Parkin-

- son's disease: a review. *Neurodegenerative Disease Management* **8**, 115–136, DOI: 10.2217/nmt-2017-0050 (2018).
- [27] Fraczek, T. M. *et al.* Closing the Loop With Cortical Sensing: The Development of Adaptive Deep Brain Stimulation for Essential Tremor Using the Activa PC+S. *Frontiers in Neuroscience* **15**, 749705, DOI: 10.3389/fnins.2021.749705 (2021).
- [28] Bu, L.-L. *et al.* Toward precision medicine in Parkinson's disease. *Annals of Translational Medicine* **4**, 26, DOI: 10.3978/j.issn.2305-5839.2016.01.21 (2016).
- [29] Rosin, B. *et al.* Closed-Loop Deep Brain Stimulation Is Superior in Ameliorating Parkinsonism. *Neuron* **72**, 370–384, DOI: 10.1016/j.neuron.2011.08.023 (2011). Publisher: Elsevier.
- [30] Little, S. *et al.* Adaptive deep brain stimulation in advanced Parkinson disease. *Annals of Neurology* **74**, 449–457, DOI: 10.1002/ana.23951 (2013). [_eprint: https://onlinelibrary.wiley.com/doi/pdf/10.1002/ana.23951](https://onlinelibrary.wiley.com/doi/pdf/10.1002/ana.23951).
- [31] Little, S. *et al.* Adaptive deep brain stimulation for Parkinson's disease demonstrates reduced speech side effects compared to conventional stimulation in the acute setting. *Journal of Neurology, Neurosurgery & Psychiatry* **87**, 1388–1389, DOI: 10.1136/jnnp-2016-313518 (2016).
- [32] Oehr, C. R. *et al.* Personalized chronic adaptive deep brain stimulation outperforms conventional stimulation in Parkinson's disease. *medRxiv* 2023.08.03.23293450, DOI: 10.1101/2023.08.03.23293450 (2023).
- [33] Ray, N. J. *et al.* Local field potential beta activity in the subthalamic nucleus of patients with Parkinson's disease is associated with improvements in bradykinesia after dopamine and deep brain stimulation. *Experimental Neurology* **213**, 108–113, DOI: 10.1016/j.expneurol.2008.05.008 (2008).
- [34] Neumann, W.-J. *et al.* Subthalamic synchronized oscillatory activity correlates with motor impairment in patients with Parkinson's disease. *Movement Disorders* **31**, 1748–1751, DOI: 10.1002/mds.26759 (2016). [_eprint: https://onlinelibrary.wiley.com/doi/pdf/10.1002/mds.26759](https://onlinelibrary.wiley.com/doi/pdf/10.1002/mds.26759).

- [35] Swann, N. C. *et al.* Adaptive deep brain stimulation for Parkinson's disease using motor cortex sensing. *J. Neural Eng.* 11 (2018).
- [36] Connolly, M. J. *et al.* Multi-objective data-driven optimization for improving deep brain stimulation in Parkinson's disease. *Journal of Neural Engineering* **18**, 046046, DOI: 10.1088/1741-2552/abf8ca (2021). Publisher: IOP Publishing.
- [37] Gilron, R. *et al.* Long-term wireless streaming of neural recordings for circuit discovery and adaptive stimulation in individuals with Parkinson's disease. *Nature Biotechnology* **39**, 1078–1085, DOI: 10.1038/s41587-021-00897-5 (2021).
- [38] Todorova, A., Jenner, P. & Chaudhuri, K. R. Non-motor Parkinson's: integral to motor Parkinson's, yet often neglected. *Practical Neurology* **14**, 310–322, DOI: 10.1136/practneurol-2013-000741 (2014). Publisher: BMJ Publishing Group Ltd Section: Review.
- [39] Wannheden, C. & Revenäs, How People with Parkinson's Disease and Health Care Professionals Wish to Partner in Care Using eHealth: Co-Design Study. *Journal of Medical Internet Research* **22**, e19195, DOI: 10.2196/19195 (2020). Company: Journal of Medical Internet Research Distributor: Journal of Medical Internet Research Institution: Journal of Medical Internet Research Label: Journal of Medical Internet Research Publisher: JMIR Publications Inc., Toronto, Canada.
- [40] Fabbri, M. *et al.* Health Literacy and Outcomes Among Patients With Heart Failure: A Systematic Review and Meta-Analysis. *JACC. Heart failure* **8**, 451–460, DOI: 10.1016/j.jchf.2019.11.007 (2020).
- [41] Bloem, B. R. *et al.* Integrated and patient-centred management of Parkinson's disease: a network model for reshaping chronic neurological care. *The Lancet. Neurology* **19**, 623–634, DOI: 10.1016/S1474-4422(20)30064-8 (2020).
- [42] Vindrola-Padros, C. *et al.* Carrying Out Rapid Qualitative Research During a Pandemic: Emerging Lessons From COVID-19. *Qualitative Health Research* **30**, 2192–2204, DOI: 10.1177/1049732320951526 (2020). MAG ID: 3082113986 S2ID: dc9b405d81b5b60724cd8add5ec9e8afb3ee08ee.

- [43] Kelly, C. J., Karthikesalingam, A., Suleyman, M., Corrado, G. & King, D. Key challenges for delivering clinical impact with artificial intelligence. *BMC medicine* **17**, 195, DOI: 10.1186/s12916-019-1426-2 (2019).
- [44] Bloem, B. R., Okun, M. S. & Klein, C. Parkinson's disease. *Lancet (London, England)* **397**, 2284–2303, DOI: 10.1016/S0140-6736(21)00218-X (2021).
- [45] Virmani, T. *et al.* Feasibility of telemedicine research visits in people with Parkinson's disease residing in medically underserved areas. *Journal of Clinical and Translational Science* **6**, e133, DOI: 10.1017/cts.2022.459 (2022).
- [46] Klucken, J., Krüger, R., Schmidt, P. & Bloem, B. R. Management of Parkinson's Disease 20 Years from Now: Towards Digital Health Pathways. *Journal of Parkinson's Disease* **8**, S85–S94, DOI: 10.3233/JPD-181519 (2018).
- [47] Borton, D. A., Dawes, H. E., Worrell, G. A., Starr, P. A. & Denison, T. J. Developing Collaborative Platforms to Advance Neurotechnology and Its Translation. *Neuron* **108**, 286–301, DOI: 10.1016/j.neuron.2020.10.001 (2020).
- [48] Stieglitz, T. Of Man and Mice: Translational Research in Neurotechnology. *Neuron* **105**, 12–15, DOI: 10.1016/j.neuron.2019.11.030 (2020).
- [49] Porch, C., Timbrell, G. & Rosemann, M. Platforms: A Systematic Review Of The Literature Using Algorithmic Historiography. (2015).
- [50] Thomas, L. D. W., Autio, E. & Gann, D. M. Architectural Leverage: Putting Platforms in Context. *Academy of Management Perspectives* **28**, 198–219 (2014). Publisher: Academy of Management.
- [51] Afshar, P. *et al.* A translational platform for prototyping closed-loop neuromodulation systems. *Frontiers in Neural Circuits* **6** (2013).
- [52] Porter, M. E. & Heppelmann, J. E. How Smart, Connected Products Are Transforming Competition. *Harvard Business Review* (2014). Section: Technology and analytics.

- [53] Kremen, V. *et al.* Integrating Brain Implants With Local and Distributed Computing Devices: A Next Generation Epilepsy Management System. *IEEE Journal of Translational Engineering in Health and Medicine* **6**, 1–12, DOI: 10.1109/JTEHM.2018.2869398 (2018). Conference Name: IEEE Journal of Translational Engineering in Health and Medicine.
- [54] Provenza, N. R. *et al.* The Case for Adaptive Neuromodulation to Treat Severe Intractable Mental Disorders. *Frontiers in Neuroscience* **13** (2019).
- [55] Goetz, C. G. *et al.* Movement Disorder Society-sponsored revision of the Unified Parkinson's Disease Rating Scale (MDS-UPDRS): Scale presentation and clinimetric testing results. *Movement Disorders* **23**, 2129–2170, DOI: 10.1002/mds.22340 (2008). _eprint: <https://onlinelibrary.wiley.com/doi/pdf/10.1002/mds.22340>.
- [56] Williams, S., Wong, D., Alty, J. E. & Relton, S. D. Parkinsonian Hand or Clinician's Eye? Finger Tap Bradykinesia Interrater Reliability for 21 Movement Disorder Experts. *Journal of Parkinson's Disease* **13**, 525–536, DOI: 10.3233/JPD-223256 (2023). Publisher: IOS Press.
- [57] Kehnemouyi, Y. M. *et al.* Modulation of beta bursts in subthalamic sensorimotor circuits predicts improvement in bradykinesia. *Brain* **144**, 473–486, DOI: 10.1093/brain/awaa394 (2021).
- [58] Mehta, D. *et al.* Towards Automated and Marker-less Parkinson Disease Assessment: Predicting UPDRS Scores using Sit-stand videos. *arXiv:2104.04650 [cs]* (2021). ArXiv: 2104.04650.
- [59] Powers, R. *et al.* Smartwatch inertial sensors continuously monitor real-world motor fluctuations in Parkinson's disease. *Science Translational Medicine* **13**, eabd7865, DOI: 10.1126/scitranslmed.abd7865 (2021). Publisher: American Association for the Advancement of Science.
- [60] Habets, J. G. V. *et al.* Rapid Dynamic Naturalistic Monitoring of Bradykinesia in Parkinson's Disease Using a Wrist-Worn Accelerometer. *Sensors* **21**, 7876, DOI: 10.3390/s21237876 (2021). Number: 23 Publisher: Multidisciplinary Digital Publishing Institute.
- [61] Cakmak, Y. O. *et al.* Hand Pronation-Supination Movement as a Proxy for Remotely Monitoring Gait and Posture Stability in Parkinson's Disease. *Sensors (Basel, Switzerland)* **22**, 1827, DOI: 10.3390/s22051827 (2022).

- [62] Melbourne, J. A. *et al.* Kinematic adaptive deep brain stimulation for gait impairment and freezing of gait in Parkinson's disease. *Brain Stimulation: Basic, Translational, and Clinical Research in Neuromodulation* **16**, 1099–1101, DOI: 10.1016/j.brs.2023.07.003 (2023). Publisher: Elsevier.
- [63] Jiang, S. *et al.* Feasibility of Wrist-Worn, Real-Time Hand, and Surface Gesture Recognition via sEMG and IMU Sensing. *IEEE Transactions on Industrial Informatics* **14**, 3376–3385, DOI: 10.1109/TII.2017.2779814 (2018). Conference Name: IEEE Transactions on Industrial Informatics.
- [64] Cao, Z., Hidalgo, G., Simon, T., Wei, S.-E. & Sheikh, Y. OpenPose: Realtime Multi-Person 2D Pose Estimation Using Part Affinity Fields. *IEEE Transactions on Pattern Analysis and Machine Intelligence* **43**, 172–186, DOI: 10.1109/TPAMI.2019.2929257 (2021). Conference Name: IEEE Transactions on Pattern Analysis and Machine Intelligence.
- [65] Xu, X. *et al.* Remote video-based outcome measures of patients with Parkinson's disease after deep brain stimulation using smartphones: a pilot study. *Neurosurgical Focus* **51**, E2, DOI: 10.3171/2021.8.FOCUS21383 (2021). Publisher: American Association of Neurological Surgeons Section: Neurosurgical Focus.
- [66] Bandini, A. *et al.* Analysis of facial expressions in parkinson's disease through video-based automatic methods. *Journal of Neuroscience Methods* **281**, 7–20, DOI: 10.1016/j.jneumeth.2017.02.006 (2017).
- [67] Meigal, A. Y., Prokhorov, K. S., Bazhenov, N. A., Gerasimova-Meigal, L. I. & Korzun, D. G. Towards a personal at-home lab for motion video tracking in patients with Parkinson's disease. In *2017 21st Conference of Open Innovations Association (FRUCT)*, 231–237, DOI: 10.23919/FRUCT.2017.8250187 (2017).
- [68] Markerless Analysis of Articulatory Movements in Patients With Parkinson's Disease | Elsevier Enhanced Reader, DOI: 10.1016/j.jvoice.2015.10.014.
- [69] Qamar, M. A. *et al.* Chapter Eighteen - Multidisciplinary Care in Parkinson's Disease. In Bhatia, K. P., Chaudhuri, K. R. & Stamelou, M. (eds.) *International Review of Neurobiology*, vol. 132 of *Parkinson's Disease*, 511–523, DOI: 10.1016/bs.irn.2017.02.001 (Academic Press, 2017).

- [70] Chaudhuri, K. R. & Odin, P. The challenge of non-motor symptoms in Parkinson's disease. In *Progress in Brain Research*, vol. 184, 325–341, DOI: 10.1016/S0079-6123(10)84017-8 (Elsevier, 2010).
- [71] van der Marck, M. A. & Bloem, B. R. How to organize multispecialty care for patients with Parkinson's disease. *Parkinsonism & Related Disorders* **20 Suppl 1**, S167–173, DOI: 10.1016/S1353-8020(13)70040-3 (2014).
- [72] Fabbri, M. *et al.* Moving towards home-based community-centred integrated care in Parkinson's disease. *Parkinsonism & Related Disorders* **78**, 21–26, DOI: 10.1016/j.parkreldis.2020.07.001 (2020).
- [73] Cohen, E. V. *et al.* Interprofessional education increases knowledge, promotes team building, and changes practice in the care of Parkinson's disease. *Parkinsonism & Related Disorders* **22**, 21–27, DOI: 10.1016/j.parkreldis.2015.11.001 (2016).
- [74] Sylvie, G. *et al.* Co-designing an Integrated Care Network With People Living With Parkinson's Disease: From Patients' Narratives to Trajectory Analysis. *Qualitative Health Research* **31**, 2585–2601, DOI: 10.1177/10497323211042605 (2021). Publisher: SAGE Publications Inc.
- [75] van der Eijk, M., Nijhuis, F. A. P., Faber, M. J. & Bloem, B. R. Moving from physician-centered care towards patient-centered care for Parkinson's disease patients. *Parkinsonism & Related Disorders* **19**, 923–927, DOI: 10.1016/j.parkreldis.2013.04.022 (2013).
- [76] Torres, L., Driscoll, M. W. & Voell, M. Discrimination, Acculturation, Acculturative Stress, and Latino Psychological Distress: A Moderated Mediation Model. *Cultural diversity & ethnic minority psychology* **18**, 17–25, DOI: 10.1037/a0026710 (2012).
- [77] Berger, M. & Sarnyai, Z. "More than skin deep": stress neurobiology and mental health consequences of racial discrimination. *Stress (Amsterdam, Netherlands)* **18**, 1–10, DOI: 10.3109/10253890.2014.989204 (2015).
- [78] Bird, C. M. *et al.* Racial Discrimination is Associated with Acute Posttraumatic Stress Symptoms and Predicts Future Posttraumatic Stress Disorder Symptom Severity in Trauma-Exposed Black Adults in the United States. *Journal of Traumatic Stress* **34**, 995–1004, DOI: 10.1002/jts.22670 (2021).

- [79] Fani, N., Carter, S. E., Harnett, N. G., Ressler, K. J. & Bradley, B. Association of Racial Discrimination With Neural Response to Threat in Black Women in the US Exposed to Trauma. *JAMA psychiatry* **78**, 1005–1012, DOI: 10.1001/jamapsychiatry.2021.1480 (2021).
- [80] Fani, N. *et al.* Racial Discrimination and White Matter Microstructure in Trauma-Exposed Black Women. *Biological Psychiatry* **91**, 254–261, DOI: 10.1016/j.biopsych.2021.08.011 (2022). Publisher: Elsevier.
- [81] Webb, E. K. *et al.* Racial Discrimination and Resting-State Functional Connectivity of Salience Network Nodes in Trauma-Exposed Black Adults in the United States. *JAMA Network Open* **5**, e2144759, DOI: 10.1001/jamanetworkopen.2021.44759 (2022).
- [82] Greene, J., Hibbard, J. H., Sacks, R., Overton, V. & Parrotta, C. D. When Patient Activation Levels Change, Health Outcomes And Costs Change, Too. *Health Affairs* **34**, 431–437, DOI: 10.1377/hlthaff.2014.0452 (2015). Publisher: Health Affairs.
- [83] Mosen, D. M. *et al.* Is Patient Activation Associated With Outcomes of Care for Adults With Chronic Conditions? *The Journal of Ambulatory Care Management* **30**, 21 (2007).
- [84] Osborn, R. & Squires, D. International Perspectives on Patient Engagement: Results From the 2011 Commonwealth Fund Survey. *The Journal of Ambulatory Care Management* **35**, 118, DOI: 10.1097/JAC.0b013e31824a579b (2012).
- [85] Edgman-Levitan, S. Partnering with Patients, Families, and Communities for Health: A Global Imperative. (2013).
- [86] Ory, M. G. *et al.* Self-Management at the Tipping Point: Reaching 100,000 Americans with Evidence-Based Programs. *Journal of the American Geriatrics Society* **61**, 821–823, DOI: 10.1111/jgs.12239 (2013). [_eprint: https://onlinelibrary.wiley.com/doi/pdf/10.1111/jgs.12239](https://onlinelibrary.wiley.com/doi/pdf/10.1111/jgs.12239).
- [87] Ory, M. G. *et al.* National Study of Chronic Disease Self-Management: Age Comparison of Outcome Findings. *Health Education & Behavior* **41**, 34S–42S, DOI: 10.1177/1090198114543008 (2014). Publisher: SAGE Publications Inc.

- [88] Kessler, D. & Liddy, C. Self-management support programs for persons with Parkinson's disease: An integrative review. *Patient Education and Counseling* **100**, 1787–1795, DOI: 10.1016/j.pec.2017.04.011 (2017).
- [89] Kessler, D. *et al.* Development of the Integrated Parkinson's Care Network (IPCN): using co-design to plan collaborative care for people with Parkinson's disease. *Quality of Life Research: An International Journal of Quality of Life Aspects of Treatment, Care and Rehabilitation* **28**, 1355–1364, DOI: 10.1007/s11136-018-2092-0 (2019).
- [90] Mestre, T. A. *et al.* Pilot Evaluation of a Pragmatic Network for Integrated Care and Self-Management in Parkinson's Disease. *Movement Disorders* **36**, 398–406, DOI: 10.1002/mds.28332 (2021). _eprint: <https://onlinelibrary.wiley.com/doi/pdf/10.1002/mds.28332>.
- [91] Kessler, D. *et al.* The Integrated Parkinson's disease Care Network (IPCN): Qualitative evaluation of a new approach to care for Parkinson's disease. *Patient Education and Counseling* **104**, 136–142, DOI: 10.1016/j.pec.2020.07.002 (2021).
- [92] Feldmann, L. K., Roudini, J., Kühn, A. A. & Habets, J. G. V. Improving naturalistic neuroscience with patient engagement strategies. *Frontiers in Human Neuroscience* DOI: 10.3389/fnhum.2023.1325154 (2024). Place: Lausanne, Switzerland Publisher: Frontiers Research Foundation Section: PERSPECTIVE article.
- [93] McCarron, T. L. *et al.* Patients as partners in health research: A scoping review. *Health Expectations : An International Journal of Public Participation in Health Care and Health Policy* **24**, 1378–1390, DOI: 10.1111/hex.13272 (2021).
- [94] Meinders, M. J., Donnelly, A. C., Sheehan, M. & Bloem, B. R. Including People with Parkinson's Disease in Clinical Study Design and Execution: A Call to Action. *Journal of Parkinson's Disease* **12**, 1359–1363, DOI: 10.3233/JPD-223190 (2022).
- [95] Levitan, B. *et al.* Assessing the Financial Value of Patient Engagement: A Quantitative Approach from CTTI's Patient Groups and Clinical Trials Project. *Therapeutic Innovation & Regulatory Science* **52**, 220–229, DOI: 10.1177/2168479017716715 (2018). Publisher: SAGE Publications Inc.

- [96] Anderson, M. & McCleary, K. K. From passengers to co-pilots: Patient roles expand. *Science Translational Medicine* **7**, 291fs25–291fs25, DOI: 10.1126/scitranslmed.aac6023 (2015). Publisher: American Association for the Advancement of Science.
- [97] Hauser, Daniel & Isacoff. Weill Neurohub.
- [98] Strandquist, G. *et al.* Bringing the Clinic Home: An At-Home Multi-Modal Data Collection Ecosystem to Support Adaptive Deep Brain Stimulation. *JoVE (Journal of Visualized Experiments)* **197**, DOI: 10.3791/65305 (2023).
- [99] Strandquist, G. *et al.* In-Home Video and IMU Kinematics of Self Guided Tasks Correlate with Clinical Bradykinesia Scores. In *2023 11th International IEEE/EMBS Conference on Neural Engineering (NER)*, 1–6, DOI: 10.1109/NER52421.2023.10123851 (2023). ISSN: 1948-3554.
- [100] Stanslaski, S. *et al.* Creating neural “co-processors” to explore treatments for neurological disorders. In *2018 IEEE International Solid - State Circuits Conference - (ISSCC)*, 460–462, DOI: 10.1109/ISSCC.2018.8310383 (IEEE, San Francisco, CA, 2018).
- [101] Rights (OCR), O. f. C. The HIPAA Privacy Rule (2008). Last Modified: 2022-03-31T17:56:44-0400.
- [102] Rights (OCR), O. f. C. The Security Rule (2009). Last Modified: 2022-10-20T13:34:12-0400.
- [103] Perrone Randy & Gilron Ro’ee. SCBS Patient Facing App (Summit Continuous Bilateral Streaming) (2021). Original-date: 2020-11-05T22:26:55Z.
- [104] Donenfled, J. A. WireGuard: Next Generation Kernel Network Tunnel. In *Proceedings 2017 Network and Distributed System Security Symposium*, DOI: 10.14722/ndss.2017.23160 (Internet Society, San Diego, CA, 2017).
- [105] Etzion. Ubuntu 20.04 and TPM2 encrypted system disk – Running Systems (2021).
- [106] Craig-Wood, N. Rclone (2023). Original-date: 2014-03-16T16:19:57Z.
- [107] Ginés Hidalgo *et al.* CMU-Perceptual-Computing-Lab/openpose (2023). Original-date: 2017-04-24T14:06:31Z.

- [108] Sellers, K. K. *et al.* Analysis-rcs-data: Open-Source Toolbox for the Ingestion, Time-Alignment, and Visualization of Sense and Stimulation Data From the Medtronic Summit RC+S System. *Frontiers in Human Neuroscience* **15**, 398, DOI: 10.3389/fnhum.2021.714256 (2021).
- [109] Ranti, C. Rune Labs Stream API.
- [110] ffmpeg development community. FFmpeg Formats Documentation.
- [111] Strandquist, G. *et al.* In-Home Video and IMU Kinematics of Self Guided Tasks Correlate with Clinical Bradykinesia Scores, DOI: 10.36227/techrxiv.22067474.v1 (2023).
- [112] Arlotti, M. *et al.* Eight-hours adaptive deep brain stimulation in patients with Parkinson disease. *Neurology* **90**, e971–e976, DOI: 10.1212/WNL.00000000000005121 (2018). Publisher: Wolters Kluwer.
- [113] Bronte-Stewart, H. M. *et al.* Perspective: Evolution of Control Variables and Policies for Closed-Loop Deep Brain Stimulation for Parkinson’s Disease Using Bidirectional Deep-Brain-Computer Interfaces. *Frontiers in Human Neuroscience* **14**, 353, DOI: 10.3389/fnhum.2020.00353 (2020).
- [114] Chen, W. *et al.* The Role of Large-Scale Data Infrastructure in Developing Next-Generation Deep Brain Stimulation Therapies. *Frontiers in Human Neuroscience* **15**, 717401, DOI: 10.3389/fnhum.2021.717401 (2021).
- [115] van den Noort, J. C. *et al.* Quantification of Hand Motor Symptoms in Parkinson’s Disease: A Proof-of-Principle Study Using Inertial and Force Sensors. *Annals of Biomedical Engineering* **45**, 2423–2436, DOI: 10.1007/s10439-017-1881-x (2017).
- [116] Virtanen, P. *et al.* SciPy 1.0: fundamental algorithms for scientific computing in Python. *Nature Methods* **17**, 261–272, DOI: 10.1038/s41592-019-0686-2 (2020). Number: 3 Publisher: Nature Publishing Group.
- [117] O’Day, J. J. *et al.* Demonstration of Kinematic-Based Closed-loop Deep Brain Stimulation for Mitigating Freezing of Gait in People with Parkinson’s Disease. *Annual International Conference of the IEEE Engineering in Medicine and Biology Society. IEEE Engineering in Medicine and Biology So-*

- ciety. *Annual International Conference* **2020**, 3612–3616, DOI: 10.1109/EMBC44109.2020.9176638 (2020).
- [118] Martin, C. M. & Félix-Bortolotti, M. Person-centred health care: a critical assessment of current and emerging research approaches. *Journal of Evaluation in Clinical Practice* **20**, 1056–1064, DOI: 10.1111/jep.12283 (2014). _eprint: <https://onlinelibrary.wiley.com/doi/pdf/10.1111/jep.12283>.
- [119] Lo Bianco, M., Pedell, S., Renda, G. & Kapoor, A. HCI Methods for Empowering Discussion on Person-Centered Fall Prevention with Older Adults. In *Proceedings of the Annual Meeting of the Australian Special Interest Group for Computer Human Interaction, OzCHI '15*, 255–263, DOI: 10.1145/2838739.2838767 (Association for Computing Machinery, New York, NY, USA, 2015).
- [120] McKay, E., Askenäs, L. & Aidemark, J. Investigating an HCI evaluation criteria framework for patient-centered eHealth solutions a case study of self-management of heart failure. In *2014 IEEE Conference on e-Learning, e-Management and e-Services (IC3e)*, 99–104, DOI: 10.1109/IC3e.2014.7081249 (2014).
- [121] de Barros, A. C., Rêgo, S. & Antunes, J. Aspects of Human-Centred Design in HCI with Older Adults: Experiences from the Field. In Sauer, S., Bogdan, C., Forbrig, P., Bernhaupt, R. & Winckler, M. (eds.) *Human-Centered Software Engineering*, 235–242, DOI: 10.1007/978-3-662-44811-3_14 (Springer, Berlin, Heidelberg, 2014).
- [122] Yamagami, M. *et al.* Centering Accessibility for Person-Centered Care Planning for MCC. (2022).
- [123] Cornet, V. P. *et al.* Patient-centered Design Grounded in User and Clinical Realities: Towards Valid Digital Health. *Proceedings of the International Symposium on Human Factors and Ergonomics in Health Care* **8**, 100–104, DOI: 10.1177/2327857919081023 (2019). Publisher: SAGE Publications.
- [124] Panchanathan, S., McDaniel, T. & Balasubramanian, V. N. An interdisciplinary approach to the design, development and deployment of person-centered accessible technologies. In *2013 International Conference on Recent Trends in Information Technology (ICRTIT)*, 750–757, DOI: 10.1109/ICRTIT.2013.6844294 (2013).

- [125] Bunniss, S. & Kelly, D. R. Research paradigms in medical education research. *Medical Education* **44**, 358–366, DOI: 10.1111/j.1365-2923.2009.03611.x (2010). _eprint: <https://onlinelibrary.wiley.com/doi/pdf/10.1111/j.1365-2923.2009.03611.x>.
- [126] Chen, C. C. *et al.* Deep brain stimulation of the subthalamic nucleus: A two-edged sword. *Current Biology* **16**, R952–R953, DOI: 10.1016/j.cub.2006.10.013 (2006). Publisher: Elsevier.
- [127] Little, S. & Brown, P. What brain signals are suitable for feedback control of deep brain stimulation in Parkinson’s disease? *Annals of the New York Academy of Sciences* **1265**, 9–24, DOI: 10.1111/j.1749-6632.2012.06650.x (2012). _eprint: <https://onlinelibrary.wiley.com/doi/pdf/10.1111/j.1749-6632.2012.06650.x>.
- [128] Opri, E. *et al.* Chronic embedded cortico-thalamic closed-loop deep brain stimulation for the treatment of essential tremor. *Science Translational Medicine* **12**, eaay7680, DOI: 10.1126/scitranslmed.aay7680 (2020). Publisher: American Association for the Advancement of Science.
- [129] Castaño-Candamil, S. *et al.* A Pilot Study on Data-Driven Adaptive Deep Brain Stimulation in Chronically Implanted Essential Tremor Patients. *Frontiers in Human Neuroscience* **14**, 541625, DOI: 10.3389/fnhum.2020.541625 (2020).
- [130] Molina, R. *et al.* Closed-Loop Deep Brain Stimulation to Treat Medication-Refractory Freezing of Gait in Parkinson’s Disease. *Frontiers in Human Neuroscience* **15**, DOI: 10.3389/fnhum.2021.633655 (2021). Publisher: Frontiers.
- [131] Bocci, T. *et al.* Eight-hours conventional versus adaptive deep brain stimulation of the subthalamic nucleus in Parkinson’s disease. *npj Parkinson’s Disease* **7**, 1–6, DOI: 10.1038/s41531-021-00229-z (2021). Publisher: Nature Publishing Group.
- [132] Provenza, N. R. *et al.* Long-term ecological assessment of intracranial electrophysiology synchronized to behavioral markers in obsessive-compulsive disorder. *Nature Medicine* **27**, 2154–2165, DOI: 10.1038/s41591-021-01550-z (2021). Publisher: Nature Publishing Group.
- [133] Bronte-Stewart, H. *et al.* Adaptive DBS Algorithm for Personalized Therapy in Parkinson’s Disease:

- ADAPT-PD clinical trial methodology and early data (P1-11.002). *Neurology* **100**, 3204, DOI: 10.1212/WNL.0000000000203099 (2023). Publisher: Wolters Kluwer.
- [134] Merner, A. R. *et al.* Participant perceptions of changes in psychosocial domains following participation in an adaptive deep brain stimulation trial. *Brain Stimulation: Basic, Translational, and Clinical Research in Neuromodulation* **16**, 990–998, DOI: 10.1016/j.brs.2023.06.007 (2023). Publisher: Elsevier.
- [135] Kögel, J., Schmid, J. R., Jox, R. J. & Friedrich, O. Using brain-computer interfaces: a scoping review of studies employing social research methods. *BMC Medical Ethics* **20**, 18, DOI: 10.1186/s12910-019-0354-1 (2019).
- [136] CERLETTI, U. Old and new information about electroshock. *American Journal of Psychiatry* **107**, 87–94, DOI: 10.1176/ajp.107.2.87 (1950). Publisher: American Psychiatric Publishing.
- [137] Haas, L. Hans Berger (1873–1941), Richard Caton (1842–1926), and electroencephalography. *Journal of Neurology, Neurosurgery, and Psychiatry* **74**, 9, DOI: 10.1136/jnnp.74.1.9 (2003).
- [138] Cometa, A. *et al.* Clinical neuroscience and neurotechnology: An amazing symbiosis. *iScience* **25**, 105124, DOI: 10.1016/j.isci.2022.105124 (2022).
- [139] Paschall, C. J., Hauptman, J. S., Rao, R. P., Ojemann, J. G. & Herron, J. Touching the Void: Intracranial Stimulation for NeuroHaptic Feedback in Virtual Reality. In *2022 IEEE International Conference on Systems, Man, and Cybernetics (SMC)*, 317–324, DOI: 10.1109/SMC53654.2022.9945366 (2022). ISSN: 2577-1655.
- [140] Schalk, G. *et al.* Translation of neurotechnologies. *Nature Reviews Bioengineering* 1–16, DOI: 10.1038/s44222-024-00185-2 (2024). Publisher: Nature Publishing Group.
- [141] Pham, M., Sample, M., Dasgupta, I., Goering, S. & Klein, E. Developing Ethical Guidelines for Implantable Neurotechnology: The Importance of Incorporating Stakeholder Input. In Thakor, N. V. (ed.) *Handbook of Neuroengineering*, 1–22, DOI: 10.1007/978-981-15-2848-4_110-1 (Springer Nature, Singapore, 2020).

- [142] Paschall, C. *Virtual Reality for Intracranial Brain Computer Interface Design and Human Neural Engineering*. Thesis (2022). Accepted: 2023-01-21T05:01:25Z.
- [143] Cruickshank, J. Positioning positivism, critical realism and social constructionism in the health sciences: a philosophical orientation. *Nursing Inquiry* **19**, 71–82, DOI: 10.1111/j.1440-1800.2011.00558.x (2012). _eprint: <https://onlinelibrary.wiley.com/doi/pdf/10.1111/j.1440-1800.2011.00558.x>.
- [144] Kandi, V. & Vadakedath, S. Clinical Trials and Clinical Research: A Comprehensive Review. *Cureus* **15**, e35077, DOI: 10.7759/cureus.35077 (2023).
- [145] Mauthner, N. S. & Doucet, A. Reflexive Accounts and Accounts of Reflexivity in Qualitative Data Analysis. *Sociology* **37**, 413–431, DOI: 10.1177/00380385030373002 (2003). Publisher: SAGE Publications Ltd.
- [146] Babones, S. Interpretive Quantitative Methods for the Social Sciences. *Sociology* **50**, 453–469 (2016). Publisher: Sage Publications, Ltd.
- [147] Heisenberg, W. Über den anschaulichen Inhalt der quantentheoretischen Kinematik und Mechanik. *Zeitschrift für Physik* **43**, 172–198, DOI: 10.1007/BF01397280 (1927).
- [148] Park, Y. S., Konge, L. & Artino, A. R. J. The Positivism Paradigm of Research. *Academic Medicine* **95**, 690, DOI: 10.1097/ACM.0000000000003093 (2020).
- [149] Hudson, L. A. & Ozanne, J. L. Alternative Ways of Seeking Knowledge in Consumer Research. *Journal of Consumer Research* **14**, 508–521 (1988). Publisher: Oxford University Press.
- [150] Carson, D., Gilmore, A., Perry, C. & Gronhaug, K. *Qualitative Marketing Research* (SAGE Publications, Ltd, 2001).
- [151] Friedman, L. M., Furberg, C. D., DeMets, D. L., Reboussin, D. M. & Granger, C. B. *Fundamentals of Clinical Trials* (Springer International Publishing, Cham, 2015).
- [152] Collier, R. Legumes, lemons and streptomycin: A short history of the clinical trial. *CMAJ* **180**, 23–24, DOI: 10.1503/cmaj.081879 (2009). Publisher: CMAJ Section: News.

- [153] Dodgson, S. The evolution of clinical trials. (2006).
- [154] De Simone, J. Reductionist inference-based medicine, i.e. EBM. *Journal of Evaluation in Clinical Practice* **12**, 445–449, DOI: 10.1111/j.1365-2753.2006.00728.x (2006). _eprint: <https://onlinelibrary.wiley.com/doi/pdf/10.1111/j.1365-2753.2006.00728.x>.
- [155] Gaille, M. “Patient’s lived experience”. *Medicine, Health Care and Philosophy* **22**, 339–342, DOI: 10.1007/s11019-019-09896-5 (2019).
- [156] Berwick, D. M. The Science of Improvement. *JAMA* **299**, 1182–1184, DOI: 10.1001/jama.299.10.1182 (2008).
- [157] Glaser, B. G. & Strauss, A. L. *The discovery of grounded theory: strategies for qualitative research* (Routledge, London New York, 2017).
- [158] Einstein, G. Situated Neuroscience: Exploring Biologies of Diversity. In Bluhm, R., Jacobson, A. J. & Maibom, H. L. (eds.) *Neurofeminism: Issues at the Intersection of Feminist Theory and Cognitive Science*, 145–174, DOI: 10.1057/9780230368385_8 (Palgrave Macmillan UK, London, 2012).
- [159] Braun, V. & Clarke, V. Toward good practice in thematic analysis: Avoiding common problems and be(com)ing a *knowing* researcher. *International Journal of Transgender Health* **24**, 1–6, DOI: 10.1080/26895269.2022.2129597 (2023).
- [160] Kontos, P. & Grigorovich, A. "Sleight of Hand" or "Selling Our Soul"? Surviving and Thriving as Critical Qualitative Health Researchers in a Positivist World. *Forum Qualitative Sozialforschung / Forum: Qualitative Social Research* **19**, DOI: 10.17169/fqs-19.2.2990 (2018). Number: 2.
- [161] Doorenbos, A. Z. Mixed Methods in Nursing Research : An Overview and Practical Examples. *Kango kenkyu. The Japanese journal of nursing research* **47**, 207–217 (2014).
- [162] Creswell, J. W. & Clark, V. L. P. *Designing and conducting mixed methods research*. Designing and conducting mixed methods research (Sage Publications, Inc, Thousand Oaks, CA, US, 2007). Pages: xviii, 275.

- [163] Ivankova, N. V., Creswell, J. W. & Stick, S. L. Using Mixed-Methods Sequential Explanatory Design: From Theory to Practice. *Field Methods* **18**, 3–20, DOI: 10.1177/1525822X05282260 (2006). Publisher: SAGE Publications Inc.
- [164] Nguy, V. *et al.* A Mixed Methods Approach to Explore the Experience of Pain and Its Management in People with Parkinson’s Disease. *Parkinson’s Disease* **2024**, 8515400, DOI: 10.1155/2024/8515400 (2024). _eprint: <https://onlinelibrary.wiley.com/doi/pdf/10.1155/2024/8515400>.
- [165] Hesse-Biber, S. Doing Interdisciplinary Mixed Methods Health Care Research: Working the Boundaries, Tensions, and Synergistic Potential of Team-Based Research. *Qualitative Health Research* **26**, 649–658, DOI: 10.1177/1049732316634304 (2016). Publisher: SAGE Publications Inc.
- [166] DeJonckheere, M., Lindquist-Grantz, R., Toraman, S., Haddad, K. & Vaughn, L. M. Intersection of Mixed Methods and Community-Based Participatory Research: A Methodological Review. *Journal of Mixed Methods Research* **13**, 481–502, DOI: 10.1177/1558689818778469 (2019). Publisher: SAGE Publications.
- [167] Ingraham, K. A., Tucker, M., Ames, A. D., Rouse, E. J. & Shepherd, M. K. Leveraging user preference in the design and evaluation of lower-limb exoskeletons and prostheses. *Current Opinion in Biomedical Engineering* **28**, 100487, DOI: 10.1016/j.cobme.2023.100487 (2023).
- [168] Ryan, L. & Golden, A. ‘Tick the Box Please’: A Reflexive Approach to Doing Quantitative Social Research. *Sociology* **40**, 1191–1200, DOI: 10.1177/0038038506072287 (2006).
- [169] Maynard, M. Methods, Practice and Epistemology: The Debate about Feminism and Research. In *Researching Women’s Lives From A Feminist Perspective* (Routledge, 1994). Num Pages: 17.
- [170] Forsythe, L. P. *et al.* Patient Engagement In Research: Early Findings From The Patient-Centered Outcomes Research Institute. *Health Affairs* **38**, 359–367, DOI: 10.1377/hlthaff.2018.05067 (2019). Publisher: Health Affairs.
- [171] Fergusson, D. *et al.* The prevalence of patient engagement in published trials: a systematic review. *Research Involvement and Engagement* **4**, 17, DOI: 10.1186/s40900-018-0099-x (2018).

- [172] Boivin, A. *et al.* Patient and public engagement in research and health system decision making: A systematic review of evaluation tools. *Health Expectations* **21**, 1075–1084, DOI: 10.1111/hex.12804 (2018). [_eprint: https://onlinelibrary.wiley.com/doi/pdf/10.1111/hex.12804](https://onlinelibrary.wiley.com/doi/pdf/10.1111/hex.12804).
- [173] Sacristán, J. A. *et al.* Patient involvement in clinical research: why, when, and how. *Patient Preference and Adherence* **10**, 631–640, DOI: 10.2147/PPA.S104259 (2016).
- [174] Weschke, S. *et al.* Reporting of patient involvement: a mixed-methods analysis of current practice in health research publications using a targeted search strategy. *BMJ Open* **13**, e064170, DOI: 10.1136/bmjopen-2022-064170 (2023). Publisher: British Medical Journal Publishing Group Section: Medical publishing and peer review.
- [175] Mason, N. R., Sox, H. C. & Whitlock, E. P. A Patient-Centered Approach to Comparative Effectiveness Research Focused on Older Adults: Lessons From the Patient-Centered Outcomes Research Institute. *Journal of the American Geriatrics Society* **67**, 21–28, DOI: 10.1111/jgs.15655 (2019). [_eprint: https://onlinelibrary.wiley.com/doi/pdf/10.1111/jgs.15655](https://onlinelibrary.wiley.com/doi/pdf/10.1111/jgs.15655).
- [176] Heckert, A. *et al.* Researchers, patients, and other stakeholders’ perspectives on challenges to and strategies for engagement. *Research Involvement and Engagement* **6**, 60, DOI: 10.1186/s40900-020-00227-0 (2020).
- [177] Riggare, S. Patient researchers — the missing link? *Nature Medicine* **26**, 1507–1507, DOI: 10.1038/s41591-020-1080-4 (2020). Number: 10 Publisher: Nature Publishing Group.
- [178] Snow, R. THE ROSAMUND SNOW SCHOLARSHIP FOR PATIENT-LED RESEARCH. .
- [179] Government of Canada, C. I. o. H. R. Strategy for Patient-Oriented Research (2018). Last Modified: 2023-11-07.
- [180] PCORI. Homepage | PCORI.
- [181] NIHR. Involve patients | NIHR.

- [182] Concannon, T. W. *et al.* A Systematic Review of Stakeholder Engagement in Comparative Effectiveness and Patient-Centered Outcomes Research. *Journal of General Internal Medicine* **29**, 1692–1701, DOI: 10.1007/s11606-014-2878-x (2014).
- [183] Domecq, J. P. *et al.* Patient engagement in research: a systematic review. *BMC health services research* **14**, 89, DOI: 10.1186/1472-6963-14-89 (2014).
- [184] Jo Brett *et al.* Mapping the impact of patient and public involvement on health and social care research: a systematic review. *Health Expectations* **17**, DOI: 10.1111/j.1369-7625.2012.00795.x (2014). MAG ID: 2049504028.
- [185] Crocker, J. C. *et al.* Impact of patient and public involvement on enrolment and retention in clinical trials: systematic review and meta-analysis. *BMJ* **363**, k4738, DOI: 10.1136/bmj.k4738 (2018). Publisher: British Medical Journal Publishing Group Section: Research.
- [186] Laurance, J. *et al.* Patient Engagement: Four Case Studies That Highlight The Potential For Improved Health Outcomes And Reduced Costs. *Health Affairs* **33**, 1627–1634, DOI: 10.1377/hlthaff.2014.0375 (2014). Publisher: Health Affairs.
- [187] O’Brien, E. C. *et al.* Clinical Commentary on “Certain Uncertainty: Life After Stroke From the Patient’s Perspective”. *Circulation: Cardiovascular Quality and Outcomes* **7**, 970–970, DOI: 10.1161/CIRCOUTCAMES.114.001484 (2014). Publisher: American Heart Association.
- [188] Shelef, D. Q. *et al.* Using stakeholder engagement to develop a patient-centered pediatric asthma intervention. *Journal of Allergy and Clinical Immunology* **138**, 1512–1517, DOI: 10.1016/j.jaci.2016.10.001 (2016). Publisher: Elsevier.
- [189] Page-Reeves, J. *et al.* A comparative effectiveness study of two culturally competent models of diabetes self-management programming for Latinos from low-income households. *BMC Endocrine Disorders* **17**, 46, DOI: 10.1186/s12902-017-0192-4 (2017).
- [190] Johnson, D. S., Bush, M. T., Brandzel, S. & Wernli, K. J. The patient voice in research—evolution of a role. *Research Involvement and Engagement* **2**, 6, DOI: 10.1186/s40900-016-0020-4 (2016).

- [191] Fetters, M. D., Curry, L. A. & Creswell, J. W. Achieving Integration in Mixed Methods Designs—Principles and Practices. *Health Services Research* **48**, 2134–2156, DOI: 10.1111/1475-6773.12117 (2013).
- [192] Clarke, B. a. *Thematic Analysis: A Practical Guide* (2024).
- [193] Saldaña, J. *The coding manual for qualitative researchers* (SAGE, Los Angeles ; London, 2016), 3e [third edition] edn. OCLC: ocn930445694.
- [194] *Biodesign Guide – Biodesign*.
- [195] Strauss, A. & Corbin, J. M. *Basics of qualitative research: Grounded theory procedures and techniques*. Basics of qualitative research: Grounded theory procedures and techniques (Sage Publications, Inc, Thousand Oaks, CA, US, 1990). Pages: 270.
- [196] Bayle, N. & J Fried, S. Movement Smoothness Differentiates Voluntary from Parkinsonian Bradykinesia. *Journal of Addiction Research & Therapy* **07**, DOI: 10.4172/2155-6105.1000264 (2015).
- [197] Bin Yoo, H., Concha, E. O. d. l., De Ridder, D., Pickut, B. A. & Vanneste, S. The Functional Alterations in Top-Down Attention Streams of Parkinson’s disease Measured by EEG. *Scientific Reports* **8**, 10609, DOI: 10.1038/s41598-018-29036-y (2018). Publisher: Nature Publishing Group.
- [198] Wu, T. *et al.* Attention to Automatic Movements in Parkinson’s Disease: Modified Automatic Mode in the Striatum. *Cerebral Cortex* **25**, 3330–3342, DOI: 10.1093/cercor/bhu135 (2015).
- [199] Hemmerling, D., Wójcik-Pdziwiatr, M., Jaciów, P., Ziółko, B. & Igras-Cybulska, M. Monitoring of Parkinson’s Disease Progression based on Speech Signal. In *2023 6th International Conference on Information and Computer Technologies (ICICT)*, 132–137, DOI: 10.1109/ICICT58900.2023.00029 (2023). ISSN: 2769-4542.
- [200] Sullivan, L. S. *et al.* Keeping Disability in Mind: A Case Study in Implantable Brain-Computer Interface Research. *Science & Engineering Ethics* **24**, 479–504, DOI: 10.1007/s11948-017-9928-9 (2018). Publisher: Springer Nature.

- [201] Thabane, L. *et al.* A tutorial on pilot studies: the what, why and how. *BMC Medical Research Methodology* **10**, 1, DOI: 10.1186/1471-2288-10-1 (2010).
- [202] Leon, A. C., Davis, L. L. & Kraemer, H. C. The role and interpretation of pilot studies in clinical research. *Journal of Psychiatric Research* **45**, 626–629, DOI: 10.1016/j.jpsychires.2010.10.008 (2011).
- [203] Nuzzo, R. Scientific method: Statistical errors. *Nature* **506**, 150–152, DOI: 10.1038/506150a (2014). Publisher: Nature Publishing Group.
- [204] Greenland, S. *et al.* Statistical tests, P values, confidence intervals, and power: a guide to misinterpretations. *European Journal of Epidemiology* **31**, 337–350, DOI: 10.1007/s10654-016-0149-3 (2016).
- [205] Andrade, C. The P Value and Statistical Significance: Misunderstandings, Explanations, Challenges, and Alternatives. *Indian Journal of Psychological Medicine* **41**, 210–215, DOI: 10.4103/IJPSYM.IJPSYM_193_19 (2019). Publisher: SAGE Publications India.
- [206] Wasserstein, R. L. & Lazar, N. A. The ASA Statement on p-Values: Context, Process, and Purpose. *The American Statistician* **70**, 129–133, DOI: 10.1080/00031305.2016.1154108 (2016). Publisher: Taylor & Francis _eprint: <https://doi.org/10.1080/00031305.2016.1154108>.
- [207] Chavalarias, D., Wallach, J. D., Li, A. H. T. & Ioannidis, J. P. A. Evolution of Reporting P Values in the Biomedical Literature, 1990-2015. *JAMA* **315**, 1141–1148, DOI: 10.1001/jama.2016.1952 (2016).
- [208] Lambdin, C. Significance tests as sorcery: Science is empirical—significance tests are not. *Theory & Psychology* **22**, 67–90, DOI: 10.1177/0959354311429854 (2012). Publisher: SAGE Publications Ltd.
- [209] Di Leo, G. & Sardanelli, F. Statistical significance: p value, 0.05 threshold, and applications to radiomics—reasons for a conservative approach. *European Radiology Experimental* **4**, 18, DOI: 10.1186/s41747-020-0145-y (2020).

- [210] Kang, J., Hong, J., Esie, P., Bernstein, K. T. & Aral, S. An Illustration of Errors in Using the P Value to Indicate Clinical Significance or Epidemiological Importance of a Study Finding. *Sexually Transmitted Diseases* **44**, 495, DOI: 10.1097/OLQ.0000000000000635 (2017).
- [211] Ghazarian, S. R. Research and Statistics: Distinguishing Statistical Significance from Clinical Importance: The Value of the P Value. *Pediatrics In Review* **32**, 73–74, DOI: 10.1542/pir.32-2-73 (2011).
- [212] Goodman, S. N. Toward Evidence-Based Medical Statistics. 1: The P Value Fallacy. *Annals of Internal Medicine* **130**, 995–1004, DOI: 10.7326/0003-4819-130-12-199906150-00008 (1999). Publisher: American College of Physicians.
- [213] Kristina Staley & Staley, K. ‘Is it worth doing?’ Measuring the impact of patient and public involvement in research. *Research Involvement and Engagement* **1**, 6–6, DOI: 10.1186/s40900-015-0008-5 (2015). MAG ID: 2119404195.
- [214] Cascio, M. A. & Racine, E. *Research Involving Participants with Cognitive Disability and Differences: Ethics, Autonomy, Inclusion, and Innovation* (Oxford University Press, 2019). Google-Books-ID: bGmtDwAAQBAJ.
- [215] Loeb, S. J. *et al.* Creating Cross-Disciplinary Research Alliances to Advance Nursing Science. *Journal of Nursing Scholarship* **40**, 195–201, DOI: 10.1111/j.1547-5069.2008.00226.x (2008). _eprint: <https://sigmapubs.onlinelibrary.wiley.com/doi/pdf/10.1111/j.1547-5069.2008.00226.x>.
- [216] Heimerl, K., Jang, E. & Ndubuisi-Obi, I. Stories from the Field (of Networking): Lessons from Deploying Research Systems in the Real World. In *Proceedings of the Second Workshop on Situating Network Infrastructure with People, Practices, and Beyond*, 15–22, DOI: 10.1145/3609396.3610547 (ACM, New York NY USA, 2023).
- [217] Vogel, A. L. *et al.* Pioneering the Transdisciplinary Team Science Approach: Lessons Learned from National Cancer Institute Grantees. *Journal of translational medicine & epidemiology* **2**, 1027 (2014).
- [218] Eberle, W., Penders, J. & Yazicioglu, R. F. Closing the loop for deep brain stimulation implants enables personalized healthcare for Parkinson’s disease patients. In *2011 Annual Interna-*

- tional Conference of the IEEE Engineering in Medicine and Biology Society*, 1556–1558, DOI: 10.1109/IEMBS.2011.6090453 (2011). ISSN: 1558-4615.
- [219] di Biase, L. *et al.* Adaptive, personalized closed-loop therapy for Parkinson’s disease: biochemical, neurophysiological, and wearable sensing systems. *Expert Review of Neurotherapeutics* **21**, 1371–1388, DOI: 10.1080/14737175.2021.2000392 (2021). Publisher: Taylor & Francis _eprint: <https://doi.org/10.1080/14737175.2021.2000392>.
- [220] Titova, N. & Chaudhuri, K. R. Personalized medicine in Parkinson’s disease: Time to be precise. *Movement Disorders* **32**, 1147–1154, DOI: 10.1002/mds.27027 (2017).
- [221] Mishima, T., Fujioka, S., Morishita, T., Inoue, T. & Tsuboi, Y. Personalized Medicine in Parkinson’s Disease: New Options for Advanced Treatments. *Journal of Personalized Medicine* **11**, 650, DOI: 10.3390/jpm11070650 (2021). Number: 7 Publisher: Multidisciplinary Digital Publishing Institute.
- [222] Chan, I. S. & Ginsburg, G. S. Personalized Medicine: Progress and Promise. *Annual Review of Genomics and Human Genetics* **12**, 217–244, DOI: 10.1146/annurev-genom-082410-101446 (2011). Publisher: Annual Reviews.
- [223] Juengst, E., McGowan, M. L., Fishman, J. R. & Settersten Jr., R. A. From “Personalized” to “Precision” Medicine: The Ethical and Social Implications of Rhetorical Reform in Genomic Medicine. *Hastings Center Report* **46**, 21–33, DOI: 10.1002/hast.614 (2016). _eprint: <https://onlinelibrary.wiley.com/doi/pdf/10.1002/hast.614>.
- [224] Dirette, D. P. Personalized medicine: Definitions, history, and implications for the OT profession. *The Open Journal of Occupational Therapy* **3**, DOI: 10.15453/2168-6408.1213 (2015).
- [225] McIntyre, A. *Participatory Action Research* (SAGE, 2008). Google-Books-ID: w0xEe6I5hHUC.
- [226] Cornish, F. *et al.* Participatory action research. *Nature Reviews Methods Primers* **3**, 1–14, DOI: 10.1038/s43586-023-00214-1 (2023). Publisher: Nature Publishing Group.
- [227] Pham, M. T., Pouratian, N. & Feinsinger, A. Engagement, Exploitation, and Human Intracranial Electrophysiology Research. *Neuroethics* **15**, 25, DOI: 10.1007/s12152-022-09502-1 (2022).

- [228] for the Multi Stakeholder Engagement (MuSE) Consortium *et al.* Engaging Patients and Other Non-Researchers in Health Research: Defining Research Engagement. *Journal of General Internal Medicine* **35**, 307–314, DOI: 10.1007/s11606-019-05436-2 (2020).
- [229] Herr, K. & Anderson, G. L. *The Action Research Dissertation: A Guide for Students and Faculty* (SAGE Publications, 2014). Google-Books-ID: OsnBAwAAQBAJ.
- [230] Duke, M. Community-Based Participatory Research. In *Oxford Research Encyclopedia of Anthropology*, DOI: 10.1093/acrefore/9780190854584.013.225 (2020).
- [231] Hayes, G. R. The relationship of action research to human-computer interaction. *ACM Transactions on Computer-Human Interaction* **18**, 1–20, DOI: 10.1145/1993060.1993065 (2011).
- [232] Lithgow, M., Garrison, P., Han Beol Jang, E. & Pacé, N. Network Wisdom: The Role of Scaffolding in Expanding Communities of Practice and Technical Competencies in Community Networks. *Canadian Journal of Communication* **47**, 271–291, DOI: 10.22230/cjc.2022v47n2a4235 (2022). Publisher: University of Toronto Press.
- [233] Ivankova, N. V. Applying mixed methods in community-based participatory action research: a framework for engaging stakeholders with research as a means for promoting patient-centredness. *Journal of Research in Nursing* **22**, 282–294, DOI: 10.1177/1744987117699655 (2017). Publisher: SAGE Publications Ltd.
- [234] Ghoshal, S. & Bruckman, A. The Role of Social Computing Technologies in Grassroots Movement Building. *ACM Transactions on Computer-Human Interaction* **26**, 18:1–18:36, DOI: 10.1145/3318140 (2019).
- [235] Freire, P. Pedagogy of the Oppressed*. In *Toward a Sociology of Education* (Routledge, 1978). Num Pages: 13.
- [236] Burnes, B. The Origins of Lewin’s Three-Step Model of Change. *The Journal of Applied Behavioral Science* **56**, 32–59, DOI: 10.1177/0021886319892685 (2020). Publisher: SAGE Publications Inc.

- [237] Marrow, A. J. *The practical theorist: The life and work of Kurt Lewin*. The practical theorist: The life and work of Kurt Lewin (Teachers College Press, New York, NY, US, 1977). Pages: xix, 290.
- [238] Friedman, B., Hendry, D. G. & Borning, A. A Survey of Value Sensitive Design Methods. *Foundations and Trends® in Human–Computer Interaction* **11**, 63–125, DOI: 10.1561/11000000015 (2017). Publisher: Now Publishers, Inc.
- [239] Karasti, H. Infrastructuring in participatory design. In *Proceedings of the 13th Participatory Design Conference: Research Papers - Volume 1*, PDC '14, 141–150, DOI: 10.1145/2661435.2661450 (Association for Computing Machinery, New York, NY, USA, 2014).
- [240] Wheatley, M. & Frieze, D. Using Emergence to Take Social Innovation to Scale. .
- [241] Wallerstein, N. & Duran, B. Community-Based Participatory Research Contributions to Intervention Research: The Intersection of Science and Practice to Improve Health Equity. *American Journal of Public Health* **100**, S40–S46, DOI: 10.2105/AJPH.2009.184036 (2010). Publisher: American Public Health Association.
- [242] Michalska, K. J., Decety, J., Zeffiro, T. A. & Lahey, B. B. Association of regional gray matter volumes in the brain with disruptive behavior disorders in male and female children. *NeuroImage. Clinical* **7**, 252–257, DOI: 10.1016/j.nicl.2014.12.012 (2015).
- [243] Michalska, K. J., Zeffiro, T. A. & Decety, J. Brain response to viewing others being harmed in children with conduct disorder symptoms. *Journal of Child Psychology and Psychiatry, and Allied Disciplines* **57**, 510–519, DOI: 10.1111/jcpp.12474 (2016).
- [244] Pasick, R., Oliva, G., Goldstein, E., Nguyen, T. & Fleisher, P. A RESOURCE MANUAL FOR RESEARCHERS. .
- [245] Slattery, P., Saeri, A. K. & Bragge, P. Research co-design in health: a rapid overview of reviews. *Health Research Policy and Systems* **18**, 17, DOI: 10.1186/s12961-020-0528-9 (2020).
- [246] Björgvinsson, E. & Keshavarz, M. Partitioning Vulnerabilities: On the Paradoxes of Participatory Design in the City of Malmö. In Dancus, A. M., Hyvönen, M. & Karlsson, M. (eds.) *Vulnerability*

in Scandinavian Art and Culture, 247–266, DOI: 10.1007/978-3-030-37382-5_12 (Springer International Publishing, Cham, 2020).

- [247] Mentis, H. M., Shewbridge, R., Powell, S., Fishman, P. & Shulman, L. Being Seen: Co-Interpreting Parkinson’s Patient’s Movement Ability in Deep Brain Stimulation Programming. In *Proceedings of the 33rd Annual ACM Conference on Human Factors in Computing Systems*, CHI ’15, 511–520, DOI: 10.1145/2702123.2702342 (Association for Computing Machinery, New York, NY, USA, 2015).

Chapter A

Appendix

A.1 Review-Cycle Questions from Anonymous Reviewers

A.2 Experiment Protocol

aDBS trials v2.0 - participant instructions

12 days of recording, 30 minutes each – not necessary to be consecutive days, but ideal to be as close together as possible. Video recording windows will be scheduled every day from 9:00-23:00pm PST. For consistency, plan to begin each trial starting at the same time each day.

Daily recording protocol:

Make sure that the PTM, CTM, and both Apple Watches are charged. Make sure that medication information has been logged for the day. 21:55 – put on both Apple Watches and begin streaming Apple Watch data using StrivePD. Ensure that the key-logger is activated. 22:00 – the first of three blocks will begin. Each of the three blocks will be approximately 10 minutes long and performed with a different device configuration. Some of these device configurations will use adaptive stimulation, but you will not know which. The order will be shuffled each day and you will advance between them using the “Switch” button.

Within each block you will:

- Connect both the left and right CTM and begin streaming data. If this is the first block of the day,

change to group D first.

- Press the “Switch” button in the SCBS app on the tablet.
- Wait approximately one minute
- Tap the INS on the chest five times in any irregular pattern. This will be used for aligning movement data from the RC+S with the watch and video data, so please make the tapping movements large and exaggerated to be easily detectable by the cameras and watches.
- Rest your hands on your lap with palms facing up for 10 seconds.
- Using a single hand at eye-level, perform index-thumb finger tapping with as big and fast of movements as possible for 20 seconds. Rest hands on lap for approximately 5 seconds, then repeat with the other hand.
- Try to orient the active hand towards the center camera.
- With one arm stretched out straight in front of you, perform hand rotations, all the way clockwise and all the way counterclockwise, as big and fast of movements as possible for 20 seconds. Rest hands on lap for approximately 5 seconds, then repeat with the other arm.
- Reach your arm straight out towards the center camera.
- Keeping one arm straight out in front of you, bend your elbow and touch your index finger to the tip of your nose, then re-straighten your arm in front of you again. Repeat these movements as large and fast as possible for 20 seconds. Rest hands on lap for approximately 5 seconds, then repeat with the other arm.
- When your arm is straight out in front of you, try to orient it towards the center camera.
- Type the text provided at the end of these instructions. The text for each day will be on a separate page, starting below these instructions. We do not need to see a record of the typing, so feel free to type in any text editor and delete it afterwards.
- Prepare for the next block.

23:00 – After the three blocks have been completed, stop streaming data on both the RC+S and Apple Watches. The video recording will stop automatically at 23:00. Connect to the PTM and return stimulation to your standard settings on both INS devices Take a nice break and have a snack for all your hard work. You may stop a recording and return to your standard stimulation at any point and for any reason.

Day 1: (Note: Day 1 the same paragraph was typed for each stim condition)

There were once three brothers who were traveling along a lonely, winding road at twilight. In time, the brothers reached a river too deep to wade through and too dangerous to swim across. However, these brothers were learned in the magical arts, and so they simply waved their wands and made a bridge appear across the treacherous water. They were halfway across it when they found their path blocked by a hooded figure. And Death spoke to them. He was angry that he had been cheated out of three new victims, for travelers usually drowned in the river.

A.3 Supplementary Method

Video frame and timestamp analysis

1. To distinguish any lags in frames and timestamps between the three cameras, program a red LED light to blink at random intervals, between 100 ms and 500 ms, for random durations, between 1 s and 5 s. Place the light within the visual field of the three cameras and its blinking is recorded using different camera configurations to evaluate time lags.
2. Assess the video output from each camera to determine the pixels that capture the blinking red light. From each frame, monitor the sum of the red channel pixel values over time. There was a distinct spike in this intensity whenever the LED light blinked. Use this to determine the frame number and timestamp designated by each camera for each LED light blink and compute the variation in lag over time by comparing them between cameras.
3. Test the FFmpeg's video segmenting functionality that is used in the authors' video recording app²². This function allows a continuous video stream to be automatically saved to disk in smaller increments. This mitigates the risk of potential large-scale data corruption (which could make a longer recording unusable) and allows for upload of files in a more controlled fashion.
4. Record blinking for three 1 h sessions with 2 min segmenting enabled. For each session, analyze the frame lags between each pair of cameras. Delineate 10 min periods within each hour with black vertical lines and only include the frame lags from the first minute for brevity.

The lags between cameras 2 and 1, 3 and 1, as well as 3 and 2, were found to be 28 ± 3 , -25 ± 3 and -53 ± 3 frames, respectively. These frame lags remained the same across three 1-hour sessions that were tested. When the same analysis was performed using the timestamps from each camera instead of the frame numbers, the lag was observed to worsen over time, indicating an unpredictable variation in the timestamps. The effect of removing the video segmenting that is programmed into the video recording application was investigated next. A single 1-hour recording had consistent frame and timestamp lags between cameras, as opposed to a 1-hour recording segmented into 2-minute chunks. This implies that creating multiple short files using the video segmenting feature is one potential cause of time synchronization issues.

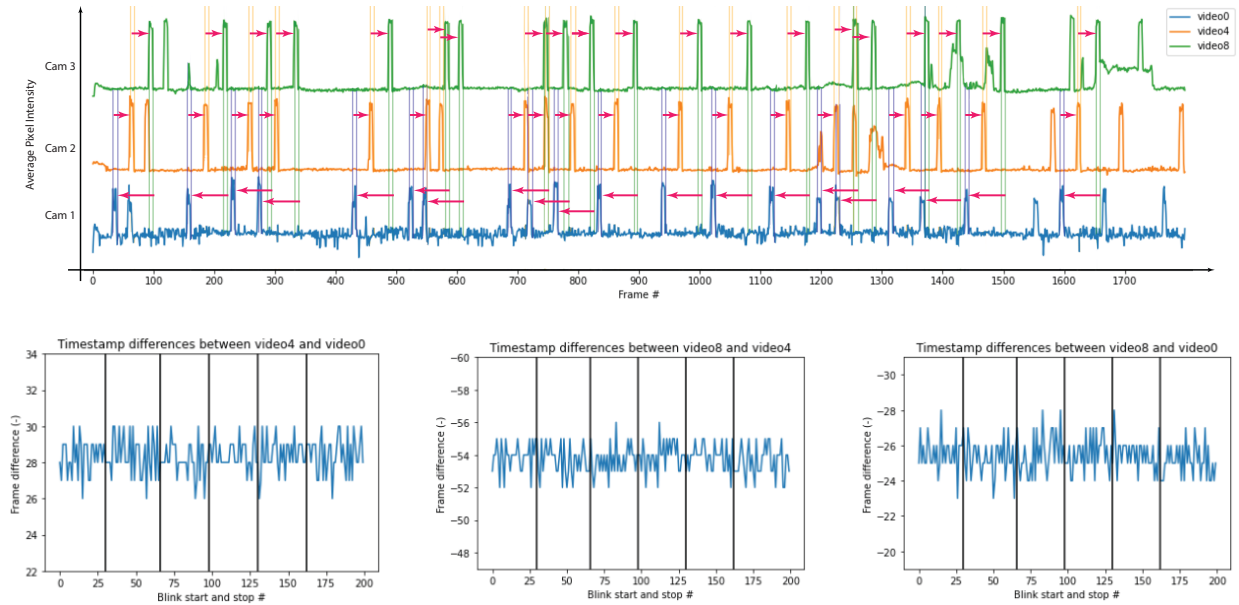

Figure A.1: Video Frame Lag Analysis: Lags in timestamps generated from the video recording app were detected during system characterization. To investigate the cause of the lags, the frame number and timestamp generated from each camera was determined by recording a red LED light that blinked at random intervals, then the variations in timestamp lags across cameras was computed. (Top) LED intensities (in RGB units) measured on each of the three cameras, demonstrating the time offsets observed between the three cameras (denoted with red arrows). (Bottom) Three plots show the between-camera timestamp lags in number of frames for a series of LED blinks over the entire recording. Each recording was broken up into multiple segments and the frame lag was approximately constant over time.

A.4 Exit Interview Questions

1. Set the theme

- (a) We'd like to know more about your experiences with DBS and all the technology that's involved.

Can you tell us what your day to day experiences have been like since you started with DBS?

2. Main narration (participant speaks till we sense they've come to a close)

3. Questioning phase

- (a) Can you tell us about your main challenges with DBS today?

- (b) Can you tell us about any changes you and your family experienced in your day to day routines after the video cameras and extra PC were installed?

- (c) Can you tell us about your experiences when you did data collection experiments?

- (d) In terms of communication, accessing any of us on the team, was there anything looking back that you wish was different, or that you would change?

4. Wrap Up:

- (a) Is there anything else you would like us to know?

A.5 Exit Interview Code Book

Table A.1: First Cycle Codebook

Code name	Memo	Modality
pain point: living with PD		Exit Interview
pain point: living with DBS		Exit Interview
pain point: participating as re- search subject	there could be pain points that come from participating in research that are not tied to having PD or DBS; e.g. ex- periencing boredom while doing an ex- periment, extra tired rest of the day af- ter doing experiments	Exit Interview
settling/downplaying needs		Exit Interview
misunderstood		Exit Interview
Isolation/loneliness		Exit Interview
participant apologizing		Exit Interview
participant expressing embar- rassment/self conscious		Exit Interview
participant expressing owner- ship/sense of responsibility		Exit Interview
experiencing boredom during experiments		Exit Interview
considering relevance of sys- tem/experiments to daily life		Exit Interview
participant brainstorming solu- tions		Exit Interview
participant innovating to adapt		Exit Interview
feeling gratitude		Exit Interview

Code name	Memo	Modality
participant concern for researchers' experience		Exit Interview
participant in perpetuated state of mystery about research outcomes		Exit Interview
forced guesswork		Exit Interview
researcher surprised		Exit Interview
participant teaching researcher	could include bringing something to researcher's attention, or trying to share an experience someone living without PD wouldn't understand or be aware of	Exit Interview
Condition disparity revealed, or disparity causes impact	i.e. participant has PD, researcher does not.	Exit Interview
Some experiments harder to execute than others due to PD impairments		Exit Interview
a different 'normal'	e.g. it's 'normal' to use body freezing as device recharge alert system	Exit Interview
participant noting areas needing improvement		Exit Interview
IDing participant needs or priorities		Exit Interview
participant shows tech/science background		Exit Interview
understanding the system alleviates fear/increases comfortability		Exit Interview

Code name	Memo	Modality
participant assessment of symptom severity		Exit Interview
participant assessment of DBS efficacy	i.e., how well DBS treats their symptoms	Exit Interview
doubt in aDBS and/or IoT capabilities		Exit Interview
doubt in medical/insurance systems		Exit Interview
Worry about performance/-longevity of implanted devices		Exit Interview
inherent ambiguity in tasks	Referring to multiple degrees of freedom that some movements have, e.g. with wrist rotations there are 2 the participant ID'd: the speed of rotation and the full range of motion	Exit Interview
Ambiguous experiment instructions	Regardless of whether a task has inherent ambiguity, this code refers to when researcher instructions were ambiguous to clarify what and/or how the participant should do something	Exit Interview
communication issues	e.g. insufficient, broken/dropped, misunderstanding, ambiguous, mismatch in preference, etc	Exit Interview

Code name	Memo	Modality
potential harms to participant	generally referring to places where DBS and/or system and/or being re-search subject can bring potential harm, rather than something PD contributes. e.g., UX design led to overly high amplitude set and participant discomfort	Exit Interview
tech issues		Exit Interview
system install or experiments impacting family routines		Exit Interview
participant/family attitude towards installed system		Exit Interview
unsure of symptom cause/source		Exit Interview
gameifying the game	devising a game to make the game of a boring experiment less boring	Exit Interview
gameifying INS-recharging routine	used concept from apex legends game kids play: "recharging my shields"	Exit Interview
gameifying incentive to clear kids from area used during experiment times	joked with kids "you'll get open pose'd"	Exit Interview
insight on what to ask re participant comms set-up in future studies		Exit Interview
seems to be guessing re study design points	Humans will try to "play by the rules" – or, if co-designing, will help you achieve your stated goals	Exit Interview

Code name	Memo	Modality
Built office shelf to store/organize all the hardware components		G-chat
created experiment guide		Exit Interview
looked into code issues with 3D pose		G-chat
frequent device troubleshooting		G-chat
tried timing experiments to make data easier for researchers to slice		Exit Interview