

Animate Biology: Data, Visualization, and Life's Moving Image

Adam J. Nocek

A dissertation
submitted in partial fulfillment of the
requirements for the degree of

Doctor of Philosophy

University of Washington

2015

Reading Committee:
Phillip Thurtle, Chair
James Tweedie
Robert Mitchell

Program Authorized to Offer Degree:
Comparative Literature

©Copyright 2015
Adam J. Nocek

University of Washington

Abstract

Animate Biology: Data, Visualization, and Life's Moving Image

Adam J. Nocek

Chair of the Supervisory Committee:
Associate Professor Phillip Thurtle

Animate Biology: Data, Visualization, and Life's Moving Image examines how biologists are using 3D animation technologies developed by the entertainment industry (Pixar and DreamWorks) to visualize biological data sets. Over the course of four chapters, the project develops a concept of scientific aesthetics in order to counter the neoliberalization of these visualization practices. The first chapter, "Molecular Control," shows how there is significant controversy among scientists regarding the scientific value of molecular animations, since it is unclear whether they faithfully depict biological data. Drawing on Lorraine Daston and Peter Galison's scholarship on the history of scientific visualization, the dissertation intervenes in this debate by clarifying what the criteria are for determining the scientific value of images. The study demonstrates that representation, instead of objectivity, is the epistemic norm that determines the scientific value of images, and that the norm of representation is fully operative in 3D molecular animations. I argue that what is often missed in debates over scientific imaging is that representation has undergone many transformations in the history of scientific epistemology, and that it now obeys the logic of flexibility and competition that exemplifies neoliberal market values. In short, the project contends that (1) molecular animations have "scientific value" inasmuch as they adhere to the norm of representation in the age of neoliberalized technoscience, and that (2) representation does not exhaust the meaning of today's molecular animations.

Using the genealogical methods that were first introduced by Michel Foucault, and that have proven so influential for media and science studies scholars, the remaining three chapters of the dissertation forge a genealogy for scientific visualization that does not rely on the values of representation; it then uses this as a framework for promoting non-representational values in scientific animation. Chapter Two, “The Micro and the Nano: New Scales of Representation,” investigates how early twentieth-century microcinematography and late-twentieth and early twenty-first-century nanoimaging appear to undermine representational values by promoting aesthetic ones. The chapter contends, however, that neither micro nor nano imaging thwart representation as the premiere value in scientific imaging, and that each practice upholds representation by finding ways to incorporate aesthetics into its logic.

The third and fourth chapters of the dissertation inquire into whether there are instances of visual aesthetics in science that cannot be incorporated into representational values. To this end, Chapter Three, “The Scientific Avant-Garde,” considers work from a scientific filmmaker who has always been on the fringes of scientific acceptability: Jean Painlevé. The study traces the development of Surrealist and Dadaist techniques in his scientific cinema, and argues that they enable his work to express that “Nature” is always in excess of the categories used to represent it. Chapter Four, “A Case for Cinematic Beauty,” then situates Painlevé’s work within a history of aesthetic philosophy that draws from Deleuze’s Kantian-inspired aesthetics. In particular, the chapter examines how Deleuze reverses the privilege given to Kant’s notion of “sublime” over the “beautiful” in Continental aesthetics, and then contends that the beautiful is the basis for Deleuze’s own aesthetic ontology, in which there is always an excess of sensibility over a priori concepts. The chapter concludes by arguing that Painlevé’s cinema expresses a similar aesthetic vision. The conclusion of the dissertation, “Molecular Aesthetics,” argues that Painlevé’s work can help

cultivate non-representational values in molecular animation. What goes unnoticed about molecular animation, I contend, is that it “de-familiarizes” biological data for scientists: it gives spatial and temporal dimensions to what have none. Drawing connections to Painlevé’s work, the project argues that molecular animations generate aesthetic experiences of data without conceptual correlates, and then demonstrates how they are transformed into what can produce neoliberal value. The dissertation ultimately contends that the seeds for aesthetic resistance to neoliberalized technoscience are already implicit in molecular animation.

Overall, the project makes a significant intervention into the visual culture of science and technology by forging a genealogy for “old” and “new” uses of visual media in science that challenges the neoliberalization of value production. In doing so, the project also brings the importance of computer animation for the critical study of science and technology, media, and Continental philosophy into full view.

Acknowledgments

The idea for this dissertation emerged out of series of intellectual exchanges I have had with colleagues and mentors over the past seven years. This project would not have been possible without the guidance and friendship of Phillip Thurtle, who encouraged me, from start to finish, to understand biology not simply as discipline, but as a way of thinking about and within life. It is under these auspices, that he first introduced me to animation as a way of orienting oneself within life. I also could not have completed this project without mentorship from my friends within the Deleuze community: Gregory Flaxman and Gregg Lambert. From them, I learned how the real challenge is to think with Deleuze and not about him. And most of all, I want to thank my wife, Stacey Moran Nocek. She challenges and transforms my thinking every day. Because of her, I'm a thinker. She is feminist, poet, and philosopher, and I owe every bit of creativity in this work to her. And finally, this work would not have been possible without the unabiding love, laughter, and joy of the two greatest gifts in my life: my daughters, Fiona and Ivy.

Contents

Introduction: Tracing New Media Histories	1
Chapter 1: Molecular Control	16
1.1 Visualizing the Invisible	16
1.2 Digital Capital	32
1.3 Life and Time Under the Control of Cybernetic Machines	37
1.4 Bad Films	43
1.5 Where Does This Leave Us?	64
Chapter 2: The Micro and the Nano: New Scales of Representation	71
2.1. Minor Histories	71
2.2 The Micro	76
2.3. The Nano	97
Chapter 3: The Scientific Avant-Garde	118
3.1 Two False Starts, or A New Research Trajectory?	118
3.2 Jean Painlevé: Scientist, Artist, Philosopher	122
3.3 Research Methods	129
3.4 The Surreal, the Fragmented, and the Ideal	142
Chapter 4: A Case for Cinematic Beauty	160
4.1. Deleuze on Kant on Beauty	162
4.2. Bio(im)political Aesthetics	178
Conclusion: Molecular Aesthetics	195

Bibliography	207
Filmography	222

Table of Figures

Figures 1&2: Taken from <i>The Inner Life of the Cell</i> (2006)	16
Figure 3: From von Andrian and Mackay's article, "T-Cell Function and Migration: Two Sides of the Same Coin," in <i>The New England Journal of Medicine</i>	17
Figure 4: A Molecular Interaction Map (MIM) of signaling from epidermal growth factor (EGF) receptors, Kurt W. Kohn, Mirit I. Aladjem, Sohyoung Kim, John N. Weinstein and Yves Pommier.....	18
Figure 5: Scanning electronic microscope image of the adhesion cascade. From Olga Barreiro and Francisco Sánchez-Madrid's article, "Molecular Basis of Leukocyte-Endothelium Interactions During the Inflammatory Response."	20
Figure 6: <i>The Inner Life of the Cell</i> (2006) attained via web search.	21
Figures 7&8: Taken from <i>The Inner Life of the Cell</i> (2006).	43
Figure 9: Twitter Network Visualization Social Graph, selected from a normal web search.	54
Figure 10. From "Substitution du noyau chez une amibe: Amoeba Sphaeronucleus," Jean Comandon and Pierre de Fonbrune, c. 1938.....	76
Figures 11&12: Worthington's symmetrical (figure 11) and asymmetrical (figure 12) splash images taken from Daston and Galison's <i>Objectivity</i>	77
Figure 13: Fertilization and development of the sea urchin embryo by Julius Ries (1907).	82
Figure 14: Jean Comondon film of syphilis using an ultramicroscope (c.1910).	85
Figure 15: Scanning Tunneling Microscope via web search.	99
Figure 16: Representation of bottom-up and top-down approaches to nanotechnology attained via web search.....	104
Figure 17: Taken from <i>The Love Life of the Octopus</i> (1965).	123

Figures 18&19: Taken from <i>The Vampire</i> (1945).....	133
Figures 20 & 21: Taken from the <i>Seahorse</i> (1934).	133
Figure 22: Taken from <i>The Love Life of the Octopus</i> (1967).	138
Figure 23: Taken from <i>Acera or The Witches' Dance</i> (1972).....	141
Figure 24: Taken from <i>Un Chien Andalou</i> (1929) via web search.....	143
Figure 25: Taken from Fernand Léger and Dudley Murphy, <i>Ballet mécanique</i> (1924).....	146
Figure 26: Fernand Léger. Oil on Canvas,1919.....	147
Figure 27: Taken from <i>Rhythm 21</i> (1921).	150
Figure 28: Piet Mondrain, <i>Tableau 1</i> , 1921.....	152

Introduction: Tracing New Media Histories

Within the last decade, there has been an undeniable surge of scholarly interest in the critical study of animation. Where just over ten years ago it was hard to find serious interest in the field, save one major journal, *Animation* (founded in 1991), and the odd publication devoted to the topic, now it is a booming area of study that cuts across multiple disciplines, including film studies, critical theory, game studies, design, and science and technology studies. Just witness the rise in popularity of a more recent journal, *Animation: An Interdisciplinary Journal* (founded in 2006), which not only boasts contributions from the world's leading film and media scholars, but is also committed to studying animation across disciplinary boundaries.¹ Also note the growing number of edited collections devoted to animation, including *Robot Ghosts and Wired Dreams: Japanese Science Fiction from Origins to Anime* (2007), *Pervasive Animation* (2013), *Animating Film Theory* (2014), *Animating Biophilosophy* (2014), as well as the mounting number of monographs published in recent years, including Thomas Lamarre's *The Anime Machine: A Media Theory of Animation* (2009), Hiroki Azuma's *Otaku: Japan's Database Animals* (2009), Suzanne Buchan's *The Quay Brothers: Into a Metaphysical Playroom* (2010), Marc Steinberg's *Anime's Media Mix Franchising Toys and Characters in Japan* (2012).

But what accounts for animation's recent rise to prominence in the Academy? Why is it, for example, that within twentieth-century film studies, animation rarely garnered recognition,

¹ See Suzanne Buchan's Editorial for *Animation: an Interdisciplinary Journal*, Nov 2006; vol. 1 No 2. And "[a]ccording to the [2012 Journal Ranking on Visual and Performing Arts](#) report published by Scimago Lab (data source: Scopus), *animation: an interdisciplinary journal* has achieved a remarkable impact in its ninth year of publication, receiving an SJR score of 0,215 and reaching the 18th position for impact and quality among the 228 international journals mapped." Taken from *Animation: An Interdisciplinary Journal's* website: <http://adri.mdx.ac.uk/contentcurator.net/animation-journal>.

except for being the poor stepchild to live-action film? The well-known media theorist, Lev Manovich, has written on this neglect, and attributes it the dominant ideology of photographic realism in film studies. He writes that,

behind the most stylized cinematic images, we can discern the bluntness, sterility, and banality of early nineteenth-century photographs. No matter how complex its stylistic innovations, the cinema has found its base in these deposits of reality... Cinema emerged out of the same impulse that engendered naturalism, court stenography, and wax museums. Cinema is the art of the index; it is the attempt to make art out a footprint (Manovich 2002: 295).

In other words, what kept animation off of the map is the fact that it does not betray the same commitment to photo-indexicality as live-action film, or the reigning notion that there is a pro-filmic real that the apparatus records. Stanley Cavell demonstrates this point vividly in his 1979 work, *The World Viewed: Reflections on the Ontology of Film*. “[T]here is a whole region of film,” he insists,

which seems to satisfy my concerns with understanding the special powers of film but which explicitly has nothing do with the projections of the real world—the region of animated cartoons... if this region of film counters my insistence upon the projection of reality as essential to the medium of movies, then it counters it completely (Cavell 1979: 167).

Of course other film theorists have complicated the relation between the cinema and traditional cel animation, including D.N. Rodowick, who notes that there is a sense in which animation is also indexical. For example, in *The Virtual Life of Film*, Rodowick writes that,

[r]egardless of the wonderfully imaginative uses to which they are put, and the spatial plasticity they record, cell animations obviously have a strong indexical quality. Simply speaking, each photographed frame records an event and its result... Here, as in all other cases, the camera records and documents a past process that took place in the physical world” (Rodowick 2007: 121).

Despite these occasional nods to animation—Dudley Andrew makes them as well (see Andrew 2010: 2-3; 30)—this “region of film” (Cavell) has remained under theorized in the history of film

criticism. And when it has been theorized, it is the preoccupations of cinema theorists—such as “indexicality” and “realism”—that frame the debate.

With the advent of digital technologies, however, animation has gained new prominence in film and media studies. One of animation’s most notable cheerleaders is of course Lev Manovich, who provocatively claims that with the advent of digital technologies all cinema has become animation: “[l]ive-action footage,” he maintains, “is now only raw material to be manipulated by hand—animated, combined with 3-D computer-generated scenes, and painted over” (Manovich 2002). Manovich goes even further than this, and claims that the cinema has always been nothing more than a particular instance of animation. Indeed, the “origins” of cinema and animation lie in magic lanterns, a nineteenth-century moving-image technology that required images to be handmade and manipulated—in short, animated. But with the emergence of cinematograph in the late nineteenth century, all references to “artifice” (*sic*) were eliminated. It is only with the emergence of digital technologies that the artifice of the cinema is once again made apparent: “*Born from animation, cinema pushed animation to its periphery, only in the end to become one particular case of animation*” (ibid.).

Of course Manovich is not the only theorist to insist that cinema is a special type of animation, although he may be the most polemical. Sean Cubitt and Suzanne Buchan, for their parts, have argued that the cinema has always been the manipulation of still images, and is therefore a special case of animation (see Cubitt 2004 and Buchan 2013). The point is that animation, once a “bastard relative” to the live-action film (Manovich), can no longer be neglected by film and media theorists. This is in part due to the fact that 3D animation technologies have all but displaced live-action footage in Hollywood features, but it also due to the fact that animation is pervasive in our digitized world (hence, the recent edited collection, *Pervasive Animation*).

Indeed, animation is so pervasive in the twenty-first century that there is even a corner of scientific research that is witnessing the mounting popularity of animation: molecular and cellular biology. In this domain of science, 3D molecular animations are on the rise, which excites many, but still scares some. In this dissertation, one of my central tasks is to understand animation's rise to prominence in biology. More precisely, the goal is to understand how 3D molecular animations, which share many of the same technical and formal features as animated feature films like *Shrek* (2001) and *Finding Nemo* (2003), could ever be taken seriously by cellular and molecular biologists. Much as Manovich did, I seek to uncover the kind of history that would allow for this technology to become so popular.

But unlike Manovich and other media theorists, I do not locate molecular animation within a history of entertainment media (although this is entirely possible, given that Pixar and DreamWorks animators are teaming up with biologists). Rather, this study will situate computer animation within a history of scientific visual culture, one that includes biological sketches, photography, microscopy, molecular cinematography, nanoimaging, and other scientific visual media. The dissertation therefore endeavors to discover a new genealogy for animation. But it is a genealogy that is less interested in criticizing the received media histories of animation,² and more concerned with ramifying the possibilities for understanding the histories in which animation participates. As we will see, the media history that I seek to trace co-exists, and at times even intersects, with the one that is often told in cinema and media studies; but it is also one that sees in computer animation the possibility of developing a superior form of representation, indeed one

² Surely, an important aspect to some approaches to media archeology is "Critique." Indeed, for early media archeologists such as Walter Benjamin, the critique of bourgeois modernity is central. As will become clear in the following chapters, the critique of neoliberal capitalism, and in particular, the way in which visual representation is configured under this system of political and economic power, will be crucial to my larger argument. I will not, however, venture a critique of the received histories of animation from twentieth-century film and media scholars. These histories have already been undermined, and continue to be, in important work by Thomas Lamarre (2009), Suzanne Buchan (2013), and others.

that far surpasses earlier visual technologies. Thus, real divergences will also emerge between the genealogy I reconstruct and the one that is often heard about animation; but they are differences that are only visible through the historical optics I provide here.

Media archeology will offer the methodological framework for this study. As recent studies in the field can attest, however, media archeology is an incredibly difficult, if impossible, area of media inquiry to define. This is in part because media archeology encompasses so many critical positions and media objects. For instance, in their Introduction to the edited collection, *Media Archeology: Approaches, Applications, and Implications*, Erkki Huhtamo and Jussi Parikka write that among the most prominent media archeologists were thinkers as diverse as Walter Benjamin, Siegfried Giedion, Aby Warburg, Marshall McLuhan, Friedrich Kittler, Siegfried Zielinski, Vilem Flusser, Geert Lovink, and many others. What this list of thinkers is supposed to signify is that media archeology inherently resists orthodoxy. The field is not one thing, but it is multiple; it churns out as many styles, approaches, and media artifacts as it does histories.

What unifies this unwieldy group of media theorists, and thus warrants bringing them all under the same banner, is nothing more and nothing less than a shared “[d]iscontent with ‘canonized’ narratives of media culture and history...” (Huhtamo and Parikka 2011: 3). Media archeologists are thus concerned with what has been forgotten or overlooked by the dominant or received media histories. They maintain that media histories tend to tell “only selected parts of the story, and not necessarily correct or relevant parts,” and this is because of either “negligence or ideological bias” (ibid.). As such, media archeology, writes Geert Lovink, is “by nature a ‘discipline’ of reading against the grain, ‘a hermeneutic reading of the ‘new’ against the grain of the past, rather than telling the histories of technologies from past to present” (Lovink in Huhtamo and Parikka 2011: ibid.). Using such a “method,” new histories emerge, indeed, histories of

forgotten, neglected, or suppressed media. These are histories that do not obey traditional disciplinary boundaries, however; they very often traverse them, and even undermine them. Media archeology can be very promiscuous in this way.³

It is with this “methodology” in mind that I seek to excavate an alternative history for one of the most pervasive technologies today. But it is in placing computer animation within the history of scientific visual culture, which I trace back to the eighteenth century, that we discover how the technology’s embrace by cellular and molecular biology is explained by twenty-first-century systems of political and economic power—i.e., neoliberalism—that condition animation’s success. In other words, computer animation becomes a visual foothold for neoliberal value production in twenty-first century technoscience. Moreover, this history will demonstrate how visual representation in the sciences has never been separate from political circuits of power, and animation is just the latest installment of this logic. It is for this reason that the dissertation asks whether this is the only genealogy for computer animation in the sciences.

Before I go onto sketch what an “alternative” to this scientific genealogy for animation might look like, there are two important points that need to be made. The first point concerns the my use of the terms “archeology” and “genealogy.” Note that my usage here does not directly correspond to the distinction between Michel Foucault’s archeological and genealogical periods, although it is indeed related to it.⁴ More precisely, archeology, at least in its contemporary usage

³ It should be noted here that many early media theorists might not be comfortable with the label, “media archeology.” To be sure, media archeology, as I’m using the term here, is a methodology of reading “against the grain” (Lovink) that has been applied to an incredibly diverse set of reading practices after the fact. Indeed, the concept itself did not gain traction in academia until after the media-studies turn in the humanities at the beginning of the twenty-first century. And it has since been popularized by media scholars such as Jussi Parikka, Erkki Huhtamo, Geert Lovink, Sean Cubitt, and others.

⁴ See in particular Michel Foucault’s *The Archeology of Knowledge* and *The Order of Things: An Archeology of the Human Sciences* for his “archeological” period, and *Discipline and Punish*, and *The History of Sexuality vol. 1* for work in his “genealogical” period. Beatrice Han has an excellent explanation of the differences between the two periods in her work, *Foucault’s Critical Project: Between the Transcendental and the Historical*.

by media theorists such as Jussi Parikka, Erkki Huhtamo, and others, functions as a genus that ranges over many different species of media archeology, including the versions espoused by Benjamin, Zielinski, Flusser, Lovink, etc. “Genealogy,” then, or at least as I’m using the term, is a particular approach to, or species of, media archeology that shares a good deal with Foucault’s own genealogical project.⁵

Foucault, for his part, believed that genealogy completes the archeological project he began in the 1960s, inasmuch as the conditions of possibility for knowledge—i.e., the archeological “epistemes” or “historical a prioris” that he fleshes out in *The Birth of the Clinic*, *the Archeology of Knowledge*, and *The Order of Things*⁶—cannot be defined only on epistemological grounds. That is to say, the conditions for “truth” cannot be studied in autonomy from the particular “will to truth” (Nietzsche) that sets it in motion. (See in particular *Discipline and Punish* and *The History of Sexuality* for Nietzsche’s influence on Foucault’s genealogical reformulation of the conditions of knowledge.)⁷ What this means is that the conditions of knowledge, according to Foucault, are inseparable from the different circuits of power that engender knowledge. Power and knowledge are inseparable. An archeology of knowledge therefore requires a genealogy—in the Nietzschean sense—of the various configurations of knowledge-power—their mutual determination. It is for this reason that Foucault writes in *Discipline and Punish* that,

it is not the activity of knowledge that produces a corpus of knowledge, useful or resistant to power, but power-knowledge, the processes and struggles that traverse it and of which it is made up, that determines the forms and possible domains of knowledge (Foucault 1991: 28).

⁵ Jussi Parikka himself notes that the way he uses the term “archeology” is closer to Foucault’s own genealogy. Unfortunately, he does not spell this relation out in much more detail. See Parikka, *What is Media Archeology*, Chapter 1.

⁶ See, for example, Foucault, *The Birth of the Clinic*, 115.

⁷ Again, Han explains the difference in wonderful detail. See Han, *Foucault’s Critical Project*, 73-107.

Similarly, the archeology of scientific visual culture that I offer here exposes how the epistemic success of an image technology is never separate from particular systems of political and economic power. Hence, this project is very much indebted to Foucault's genealogical methods. Thus, if it is a media archeology that I provide, then it is only in the very precise sense that this archeology is also a genealogy.

This brings me to my second point, which concerns my use of "neoliberalism." While I trace various domains of scientific visual culture and their corresponding regimes of "power-knowledge," I am most concerned with the reigning system of political and economic power, or what is popularly known as neoliberalism. Generally, neoliberalism designates a period within the history of Western capitalism that emerged in the 1970s and 1980s and continues to affect us today.⁸ At the most basic level, neoliberalism updated the classical liberalism of Adam Smith, David Ricardo, and others, rejected Keynesian economics (or a "mixed economy" that requires the government to intervene in the flows of capital, especially during recession⁹), and ushered in the global spread of deregulated markets, or the market fundamentalism theorized by Milton Friedman (Chicago School) and Friedrich von Hayek (Austrian school).¹⁰ And, yet, just what "neoliberalism" meant for these original theorists differed. Hayek, for example, argued for what is commonly referred to a "classical neoliberalism," which differs in significant respects from the "economic neoliberalism" advocated by Friedman and the Chicago School, and is what we usually mean by the term today.

⁸ For a clear and concise introduction to the uneven emergence of neoliberalism in latter half of the twentieth century, see David Harvey, *A Brief History of Neoliberalism*.

⁹ See John Maynard Keynes, *The General Theory of Employment, Interest and Money*.

¹⁰ See Milton Friedman, *Capitalism and Freedom*, and Friedrich von Hayek, *The Road to Serfdom: Texts and Documents: The Definitive Edition*

While I do not want to get into the differences between neoliberalisms here, suffice it to say that Friedman's economic neoliberalism, which was codified and sanctified by the Chicago School, is best described as the elimination of governmental interference in the flows of capital.¹¹ For Friedman and his colleagues, supply, demand, unemployment, and inflation exist in equilibrium when they are truly free—that is, when there is no external regulation. Economies are self-regulating. As Naomi Klein rightly points out, economies and natural systems, according to this doctrine, obey the same laws: they are self-regulating systems that become “sick” when there is too much interference from the outside (see Klein 2007: 61; Cooper 2008). In this way, neoliberalism is deeply utopian.

The problems with this view of the market abound, and principle among them is the fact that when neoliberal theory is put into practice—for example, in Chile in the 1970s (via the “Chicago Boys”), in Russia in the 1990s, and on a global scale today—it generates grave economic disparities (see especially, Piketty 2013; and Harvey 2007). David Harvey explains that while neoliberal *theory* indexes a deeply utopian project for the “reorganization of international capitalism,” *in practice* it is a “*political* project to re-establish the conditions for capital accumulation and to restore the power of economic elites” (Harvey 2007: 19). Unfortunately, the economic disparities that emerged from the actual implementation of neoliberal policies were most often explained by recourse to neoliberal theory. For example, Friedman is famous for claiming that such disparities result from a failure to create genuinely free markets—which is precisely how he explained the atrocities in Chile, including a 20% unemployment rate and the rise of “crony capitalism” (see Klein 2007: 91-120). One of the most convincing criticisms of this explanation is

¹¹ See David Harvey, *A Brief History of Neoliberalism*; Wendy Brown, “Neoliberalism and the End of Liberal Democracy”; Noam Chomsky, *Profit Over People: Neoliberalism and the Global Order*; and Naomi Klein, *The Shock Doctrine: The Rise of Disaster Capitalism*.

that neoliberal theory is flawed from the outset, inasmuch as genuinely “free markets” presuppose a (utopian) distinction between economic, political, social, and cultural forces, which does not exist; and this is what explains neoliberalism’s inability to deliver on its naïve promises (see Klein 2007; Lazzarato 2014).

What interests me in this dissertation, however, is the extent to which this understanding of the market has saturated not only those spheres of life that we would normally consider “economic,” but also those spheres that would seem to have nothing to do with economics. In his 1978-1979 lectures at the Collège de France, *The Birth of Biopolitics*, Foucault explains that for neoliberals, political economy is not simply one dimension of a wider social field, but subsumes all aspects of social life: there is a “generalization,” he insists, “of the economic form of the market. It involves generalizing it throughout the social body and including the whole of the social system not usually conducted through or sanctioned by monetary exchanges” (Foucault 2008: 243). It is this generalization of market principles that concerns me. Thus, I am deeply indebted to Foucault’s work on “neoliberal governmentality,” which in many ways seems to fill out his work on biopower and biopolitics (see Chapter 1).

But even more important for me is Gilles Deleuze’s (largely incomplete) reflections on post-disciplinary “societies of control.” This is for a couple reasons. The first reason is that Deleuze’s notion of “control” extends Foucault’s own work on neoliberal forms of power and their production of neoliberalized subjectivities, but it does so without resorting to highly suspect forms of resistance such as the “care of the self.”¹² And the second, and perhaps most important, reason for looking to Deleuze is that he focuses on how the neoliberalization of society is coextensive

¹² Foucault has often been criticized for his work on ethics and care of the self. It strikes some critics as too neoliberal. See Jeffery Nealon’s work, *Foucault Beyond Foucault*, for a careful assessment of this accusation and a well-argued rebuttal.

with the ubiquity of digital technologies—or the “cybernetization of life.” And since much of my own work involves describing neoliberalization digital science, Deleuze’s reflections will prove invaluable. Along the way, deep resonances will also emerge between the cybernetized society I describe and the work currently being done on cognitive, affective, and semio-capitalism by critical theorists influenced by the (post-)Autonomist tradition of Marxism in Italy.¹³

In all of this, what will emerge is that my use of term “neoliberalism” stems from work by Deleuze and Foucault, as well as those associated with Italian Marxism; but more than anything, it is rooted in my concern for how certain spheres of knowledge and subjectivity, which may have at one point seemed relatively separate from the logic of capital, presuppose the inherent truth of the laws of the market. As we will see, this explains what is shaping the epistemic norms in scientific visual culture today, and is exemplified in the growing field of molecular animation.

This brings me back to my earlier question: Is there another use or potential for molecular animation? Or is it simply that computer animation is locked into reproducing market values when it is used as a scientific tool? To answer this question, in the second half of the dissertation I draw heavily on the work of Deleuze and Félix Guattari, as well as Foucault, Immanuel Kant, and Alfred North Whitehead, to discover other potentials for molecular animation, ones that do not reproduce neoliberal values. To do so, the study excavates a lesser-known history of scientific visibility in order that it may be drawn on and extended into the present. As we will see, this is a history that brings the political control of the scientific image into full view by interrupting it, by releasing its firm grip on scientific visibility. Such a history includes work by avant-garde artists and

¹³ See Karl Marx, *The Grundrisse*; Negri, *Marx Beyond Marx: Lessons on the Grundrisse*; Paolo Virno, *A Grammar of the Multitude: For an Analysis of Contemporary Forms of Life*; Maurizio Lazzarato, “Immaterial Labor” and *The Making of the Indebted Man*; Franco “Bifo” Berardi, *The Uprising: On Poetry and Finance* and *The Soul at Work: From Alienation to Autonomy*; and Hardt and Negri, *Empire* and *Multitude: War and Democracy in the Age of Empire*.

filmmakers from the early and mid twentieth century, and generates a history of nonrepresentational scientific aesthetics that runs counter to the received history of visual representation in the sciences. The project ultimately contends that this lineage lies dormant within molecular animation, and requires new habits of thought (Whitehead) to cultivate in the present. This will prepare the groundwork for me to claim in the Conclusion of the dissertation that Whitehead's theory of the "proposition" best describes how it is that molecular animation could generate an aesthetic disruption to the neoliberal production of value in the visual culture of science.

What stands out about computer animation, then, is that it is not locked into one history, one that is told from the past to the present. As we will see, animation, in its contemporary avatars, unlocks multiple histories. Where the dominant modes of film and media criticism tend to locate animation within a history of entertainment media, and then claim that it is only secondarily a technology for science, design, and so on, this study treats the technology as fully a part of scientific history. Indeed, in this study alone we trace two different scientific genealogies for the technology. The first history places animation within a long line of representational visual media in the sciences; while the second one places it on the fringes of scientific acceptability, indeed, within a history of "avant-garde science" that interrupts the dominant modes of political power that control scientific visual culture. In this way, molecular animation is an exemplary site for media archeology, inasmuch as it ramifies histories, tracing so many historical lines from the same starting point. But if I end up promoting one history over another one, this is not to deny or suppress a history, so much as it is to appreciate how passing through one genealogy can unlock others that may prove beneficial to the future.

The four chapters in this dissertation bring together case studies from the archives of scientific and media history with theoretical work from the history of European philosophy, media theory, and science and technology studies. This somewhat idiosyncratic collection of resources serves the dual purpose of (1) excavating the many histories in which computer animation participates, and (2) unlocking the futures to which it can help promote.

The first chapter, “Molecular Control,” shows how there is significant controversy among scientists regarding the scientific value of molecular animations, since it is unclear whether they faithfully depict biological data. Drawing on Lorraine Daston and Peter Galison’s scholarship on the history of scientific visualization, the dissertation intervenes in this debate by clarifying what the criteria are for determining the scientific value of images. The study demonstrates that representation, instead of objectivity, is the epistemic norm that determines scientific value in this domain, and that the norm of representation is fully operative in 3D molecular animations. I argue that what is often missed in debates over scientific imaging is that representation has undergone many transformations in the history of scientific epistemology, and that it now obeys the logic of flexibility and competition that exemplifies neoliberal market values. In short, the chapter contends that (1) molecular animations have “scientific value” inasmuch as they adhere to the norm of representation in the age of neoliberalized technoscience, and that (2) representation does not exhaust the meaning of today’s molecular animations.

Using the genealogical methods that were first introduced by Michel Foucault, and that have proven so influential for media and science studies scholars, the remaining three chapters of the dissertation forge a genealogy for scientific visualization that does not rely on the values of

representation; it then uses this as a framework for promoting non-representational values in scientific animation. Chapter Two, “The Micro and the Nano: New Scales of Representation,” investigates how early twentieth-century microcinematography and late-twentieth and early twenty-first-century nanoimaging appear to undermine representational values by promoting aesthetic ones. The chapter contends, however, that neither micro nor nano imaging thwart representation as the premiere value in scientific imaging, and that each practice upholds representation by finding ways to incorporate aesthetics into its logic.

The third and fourth chapters of the dissertation inquire into whether there are instances of visual aesthetics in science that cannot be incorporated into representational values. To this end, Chapter Three, “The Scientific Avant-Garde,” considers work from a scientific filmmaker who has always been on the fringes of scientific acceptability: Jean Painlevé. The study traces the development of Surrealist and Dadaist techniques in his scientific cinema, and argues that they enable his work to express that “Nature” is always in excess of the categories used to represent it. Chapter Four, “A Case for Cinematic Beauty,” then situates Painlevé’s work within a history of aesthetic philosophy that draws from Gilles Deleuze’s Kantian-inspired aesthetics. In particular, the chapter examines how Deleuze reverses the privilege given to Kant’s notion of “sublime” over the “beautiful” in Continental aesthetics, and then contends that the beautiful is the basis for Deleuze’s own aesthetic ontology, in which there is always an excess of sensibility over a priori concepts. The chapter concludes by arguing that Painlevé’s cinema expresses a similar aesthetic vision. The conclusion of the dissertation, “Molecularizing Aesthetics,” argues that Painlevé’s work can help cultivate nonrepresentational values in molecular animation. What goes unnoticed about molecular animation, I contend, is that it “de-familiarizes” biological data for scientists: it gives spatial and temporal dimensions to what have none. Drawing connections to Painlevé’s

work, the project argues that molecular animations generate aesthetic experiences of data without conceptual correlates, but then shows how they are too often transformed into what can produce neoliberal value. Relying on Alfred North Whitehead's concept of the "propositional lure for feeling," the dissertation ultimately contends that the seeds for aesthetic resistance to neoliberalized technoscience are already implicit in molecular animation, and that they can be cultivated to lure us into feeling the molecular world aesthetically.

Chapter 1: Molecular Control

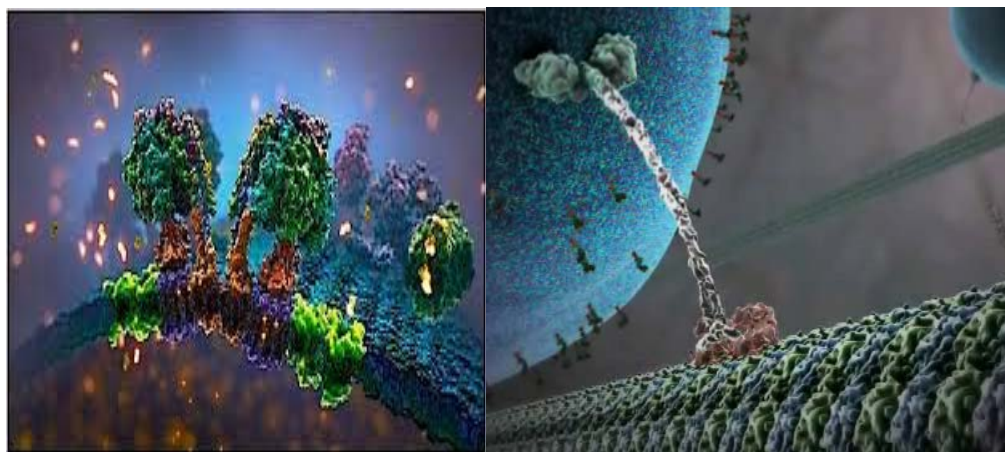

Figures 1&2: Taken from *The Inner Life of the Cell* (2006)

1.1 Visualizing the Invisible

The Inner Life of the Cell (2006) is an 8.5-minute long 3D animation made by David Bolinsky, John Liebler, and Mike Astrachan at the XVIVO Scientific Animation for Harvard University's Department of Molecular and Cellular Biology. The short film depicts the “rolling” movement of a white blood cell in the human body during leukocyte extravasation, or the movement of blood cells out of the circulatory system toward a site of infection or damage in a host.¹⁴

Although *The Inner Life of the Cell* is perhaps the most widely distributed and well-received visualization of leukocyte extravasation—it was first screened at the 2006 SIGGRAPH in Boston—visual representations of the process vary widely. As the immune system's “first line of defense,” researchers are keen to use a range of visual technologies— from electron microscopy to computer graphics—to represent this incredibly important process in exhaustive detail. The Charles Mackay laboratory, for example, researches the mechanisms of immune cell migration,

¹⁴ See Grasso, Gangolli and Gaunt's *Essentials of Pathology for Toxicologists*.

and in 2000, von Andrian and Mackay published the below graphic in the *New England Journal of Medicine*.

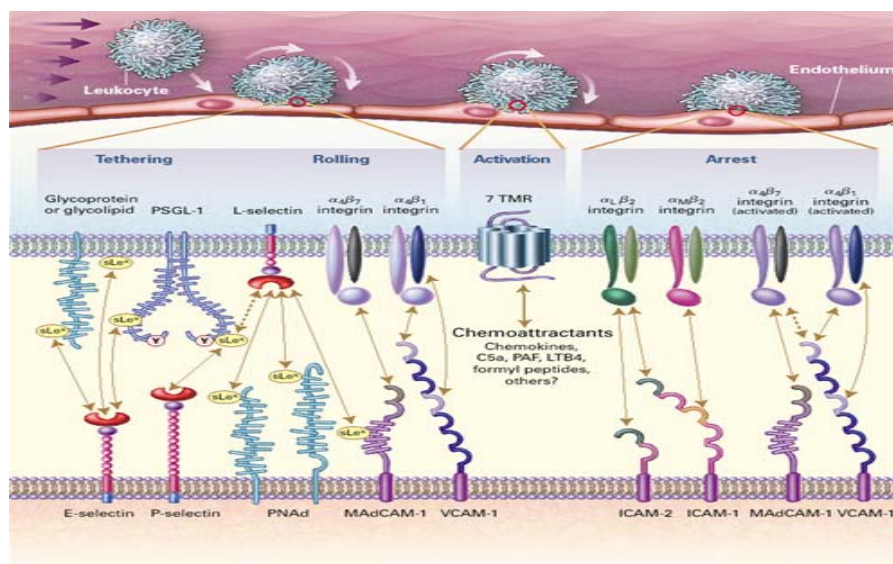

Figure 3: From von Andrian and Mackay’s article, “T-Cell Function and Migration: Two Sides of the Same Coin,” in *The New England Journal of Medicine*.

At first sight, the graphic appears to have vague aesthetic resemblances to the *Inner Life of the Cell*. The leukocyte has a “cartoonish” irregular shape (not to be confused with the red blood cell), and the adhesion molecules are depicted mechanistically (see also Figure 2), as if they were mechanical parts of a well-oiled machine—a “molecular machine.” Thus, the graphic does a good deal of interpretive work, like the animation, to communicate the “machine-like” process of cell extravasation. It goes without saying that this graphic delivers far less aesthetic delight than the 3D animation—movement over time, stunning graphics, fly-throughs, and so on; but make no mistake, it does other descriptive work as well. It provides detailed information about the causal relation among adhesion molecules that regulate the rolling movement of the white blood cell along the endothelium cells. In this way, the graphic also bears some vague resemblance to Molecular Interaction Maps (MIMs) that Systems Biologists use to depict cellular and molecular

interactions,¹⁵ though it does not hold to their standardized notation, minimalist aesthetic, and exhaustive detail.

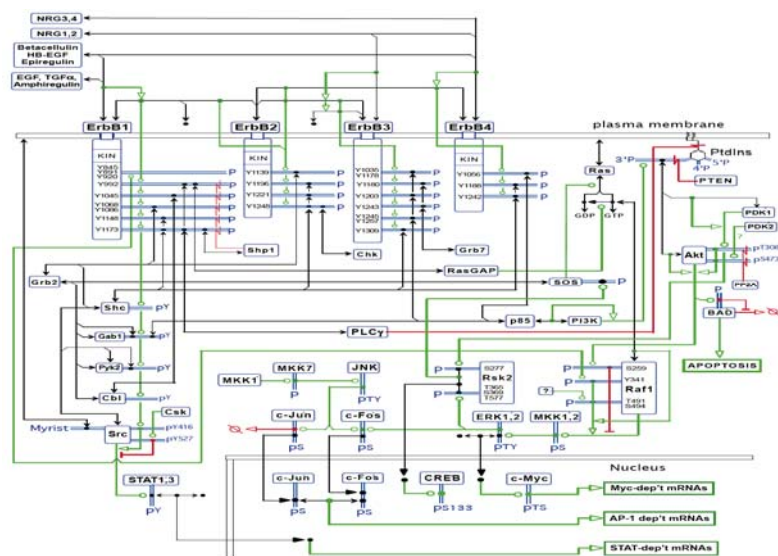

Figure 4: A Molecular Interaction Map (MIM) of signaling from epidermal growth factor (EGF) receptors, Kurt W. Kohn, Mirit I. Aladjem, Sohyoung Kim, John N. Weinstein and Yves Pommier.¹⁶

The point is that von Andrian and Mackay’s graphic is in one sense highly interpretive insofar as it attempts to communicate the “machinic quality” of unseen molecular interactions; and in another sense, it is an informative visualization insofar as it maps the causal relations among cellular and molecular processes.

¹⁵ MIMs were first introduced by Kurt W. Kohn in 1999. The map has become an essential tool allows scientists to visualize molecules wide-range of interactions. Since it’s introduction, the notation on MIMs have become increasingly standardized. Please see Kohn, “Molecular Interaction Map of the Mammalian Cell Cycle Control and DNA Repair System,” and the Systems Biology Graphical Notation consortium (http://www.sbgng.org/Main_Page), which standardizes graphical notation.

¹⁶ <http://discover.nci.nih.gov/mim/view.jsp?MIM=EGFR&selection=map>

However, there is no doubt in the minds of many scientists using biological data visualizations that they are abstractions, albeit incredibly useful ones.¹⁷ As Tami I. Spector recently noted, computer graphics re-present a set of relationships (spatial, causal, and so on) in the molecular world in a different medium, but they are not to be confused for the “real” thing (see Spector 2013). Data about leukocyte extravasation is isolated and translated into visual form so that very specific information about the real process is communicable. In other words, the graphic communicates information about a set of events, but it is not the event itself—and it is not meant to be.¹⁸ Another way to put this would be to say that scientists very often have a conservative view of media and information technology:¹⁹ the computer graphic is believed to be a technical medium for communicating meaningful content. If the medium fails to deliver the message by introducing too much of its own content, or “mediation,” and thus distracts or muddles the original message—i.e., there is “noise”—then it is too disruptive to be a reliable means of information delivery for scientific research.

Advances in microscopy offer scientists another way of understanding molecular interactions. The scanning electron microscope (SEM), for instance, gives us a compelling image

¹⁷ See Peter Weibel and Ljiljana Fruk’s edited collection, *Molecular Aesthetics*. Also see Natasha Myers excellent ethnographic work on protein crystallographers, “Molecular Embodiments and the Body-work of Modeling in Protein Crystallography.”

¹⁸ Serious controversy abounds in the field of STS over the truth of this claim. While scientists themselves remain, for the most part, deeply conservative about their views concerning what is “real” and what is a (mere) “model” (see Turkle 2009), both Lorraine Daston and Peter Galison, in their co-authored and single-authored texts, argue that simple notions of model and reality are coming to a close, even among scientists (see Daston 2008, 2014; and Daston and Galison 2007). Of course STS scholars have long since been aware that these notions are naïve, and that they presuppose an outdated understanding of representation based upon “origin” and “copy.” See Ian Hacking, *Representing and Intervening: Introductory Topics in the Philosophy of Natural Science*, and Bruno Latour, *We Have Never Been Modern*.

¹⁹ This notion of “media” presupposes an outdated set of theories in which the media is nothing but a channel meant to communicate already-determined content with the least amount of interference, or “noise.” This notion of media has been handed down to us from Claude Shannon’s original 1948 paper, “A Mathematical Theory of Communication,” and republished in his co-authored book with Warren Weaver, *The Mathematical Theory of Communication*. Essentially, this theory fails to account for the “materiality of media,” which is to say, that the medium and the message can never be separated. Please see N. Katherine Hayles, *How We Became Posthuman: Virtual Bodies in Cybernetics, Literature, and Informatics*, for a more detailed account of the relation among information, media, and materiality. Also see Marshall McLuhan’s *Understanding Media: The Extensions of Man*.

of leukocyte extravasation. By scanning the sample through an electron beam, which interacts with the atoms of the sample, data about the sample's topography is generated. Though microscopy has its own history of controversy,²⁰ compared to computer rendering, the SEM gives the *impression* that the whims of human interpretation don't interfere as much the visual reproduction of the cellular process.

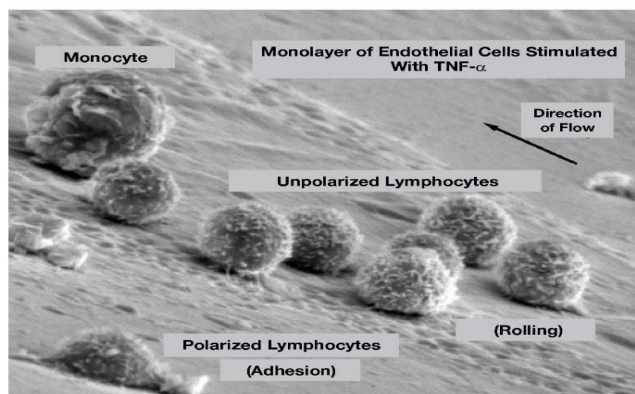

Figure 5: Scanning electronic microscope image of the adhesion cascade. From Olga Barreiro and Francisco Sánchez-Madrid's article, "Molecular Basis of Leukocyte-Endothelium Interactions During the Inflammatory Response."

But now, in the twenty-first century, with biological data sets that are so incredibly large, and referencing phenomena at spatial and temporal scales that are impossible to see in the lab, scientists are left to measure these structures numerically. And as Jason Sharpe and his colleagues at the University of Toronto insist, this situation leaves scientists scrambling to discover, and even invent, new tool sets that can close the gap between the overabundance of "esoteric data" and visual maps that can give it meaningful form (Sharpe et al. 2008, 4). It is no wonder then that

[c]omputer screens have pride of place in laboratories and scientific offices, where researchers' attentions are as likely—or more likely—to be focused on colorful digital images, simulations, software suites, databases, or lines of code as on unruly specimens or

²⁰ See Ian Hacking, *Representing and Intervening: Representing and Intervening: Introductory Topics in the Philosophy of Natural Science*; Lisa Cartwright, *Screening the Body: Tracing Medicine's Visual Culture*; and Evelyn Fox Keller, *Making Sense of Life: Explaining Biological Development with Models, Metaphors, and Machines*.

instruments. Biomedical imaging enrolls fMRI and PET scans alongside X-rays, which themselves are frequently digitally manipulated to produce new modes of vision... (Coopmans *et al.* 2014: 1).

Given that computer images are so ubiquitous in the scientific setting, it should therefore come as no surprise that 3D animation has become a useful tool for scientists trying to visualize the dynamic movements of molecular and cellular worlds. But at first sight, films such as *The Inner Life of the Cell* seem far indeed from the kind of rigorous scientific visualization of data that scientists are looking for. In fact, the film is so stylized, complete with fly-throughs, nondiagetic sound, fluid movement into depth, and striking colors, that it is hard not to see the piece as more Hollywood than the accurate visualization of data.²¹

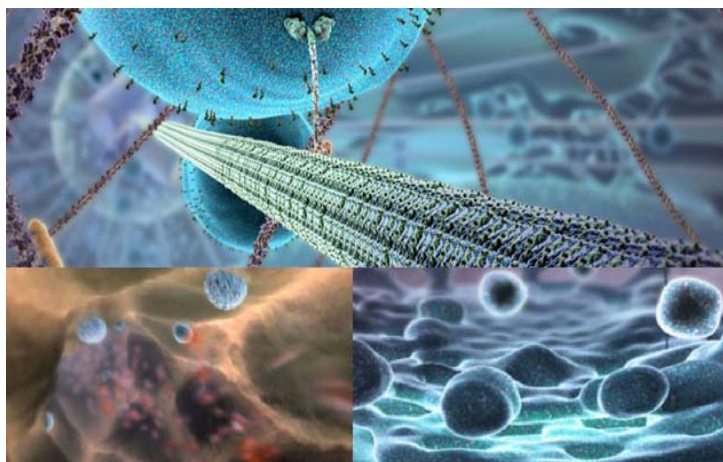

Figure 6: *The Inner Life of the Cell* (2006) attained via web search.

Despite the obvious Hollywood production quality of molecular movies, many biologists insist on their importance for data visualization. The argument goes something like this: molecular animations are the most significant visual tool yet for mapping the molecular world's change over

²¹ See Gael McGill's commentary in *Cell*: "Molecular Movies...Coming to a Lecture Near You."

time in the context of much larger environments. In this way, they excel at depicting spatial and temporal relationships that have never been seen before. And such visual information goes a long way to making invisible processes intelligible. As the scientist and animator, Gael McGill, recently noted: although the molecular world is not static and isolated, unfortunately, most, if not all, of the molecular visualization tools render that world rich in information but without a sense of the dynamic context in which it unfolds (see McGill 2008). Similarly, Tomas Kirchhausen, professor of cell biology at Harvard Medical School, remarks that

All we had before – microscopy, X-ray crystallography— were... snapshots. For me... animations are a way to glue all this information together in some logical way. By doing animation I can see what makes sense, what doesn't make sense. They force us to confront whether what we are doing is realistic or not.²²

Arguments such as these abound in the growing field of molecular and cellular animation. The most extensive defense and illustration of molecular animation is articulated perhaps by Sharpe, Lumsden, and Woolridge in their extensive work, *In Silico: 3D Animation and Simulation of Cell Biology with Maya and MEL*. While many object to using 3D animation to visualize molecular and cellular process (see below), Sharpe and his colleagues provide an argument for its *scientific* relevancy. Although the majority of their extensive text is tutorial (leading scientists and artists through a step-by-step tutorial of how to use MEL, the scripting language, and Maya Autodesk, for animating molecular processes), the first two chapters make a strong case for why 3D animation— using Maya in particular—is the logical next step in scientific visualization.

There are two main premises to the argument. I must admit that the first premise relies on a rather naïve assumption about the relation between computation and biology, which is only held

²² Quote taken from Erik Olson's 2010 article in the *New York Times*, "Where Cinema and Biology Meet."

by a handful of biologists.²³ In any case, what they maintain is that biology is best explained in computational terms, which is to say, the universe is fundamentally “computational,” and living systems are but one kind of highly complex computing system among others.²⁴ Their rhetoric incredibly is strong:

[c]ivilizations equipped with powerful computers must ... be in a position to greatly accelerate the rate at which they gain understanding of living matter. Cells obey the laws of chemistry and chemistry obeys the laws of physics. The laws of physics and chemistry are, in turn, intensely and fundamentally mathematical. One must conclude that mathematical calculating machines—capable of large scale computing based on enormous volumes of data and information—can be used to analyze, predict, and ultimately re-design the biochemical activity of cells and organisms (Sharpe et al. 2008: 35).

From their perspective, the twentieth-century revolutions in computer science and software engineering were also revolutions in biochemistry and cell biology. Denying the wealth of biological research that suggests that life is a system of irreducible relationships,²⁵ they contend that “[t]here is no evidence” for distinguishing “life” from any other chemical system; indeed, there is no “mysterious, supernatural ‘life force,’” they insist, “acting alongside the chemistry of living matter” (ibid). Calling vitalism a “myth” that has plagued biology for centuries,²⁶ they maintain that “a deep understanding of biological molecules and their interactions,” afforded to scientists through mathematics, “appears necessary and sufficient to answer the question ‘What is life?’” (ibid). Bemoaning the fact that computer-programming languages have advanced well beyond those in cell science, they contend that we nevertheless get “glimpses of the cell’s ‘machine code,’” which is what propels some of the most interesting and rewarding work in cell science today (41).

²³ See, for example, Lily E. Kay, *Who Wrote the Book of Life?: A History of the Genetic Code*; Evelyn Fox Keller, *The Century of the Gene*; and Richard Lewontin, *The Triple Helix: Gene, Organism, and Environment*.

²⁴ See Stephen Wolfram, *A New Kind of Science*.

²⁵ See Lily E. Kay, *Who Wrote the Book of Life?: A History of the Genetic Code*.

²⁶ See Timothy Lenoir, “Kant, Blumenbach, and Vital Materialism in German Biology,” and Robert Mitchell, *Experimental Life: Vitalism in Romantic Science and Literature*.

It should come as no surprise that the history Sharpe and his colleagues provide is a history of technical progress instead of a history of technical transformation rooted in disciplinary, discursive, and political economic forces.²⁷ Indeed, their history, which is arguably in the minority today, is one in which the computational intelligence, inherited from Alan Turing, John von Neumann and first-wave cybernetics, fundamentally gets us closer to solving the universe's greatest mysteries, including life itself.

The second premise for their argument, which is somewhat more palatable, that computer animation provides a legitimate, and indeed, scientific, means to visualize biological data is that visual perception is invaluable to biological science. Reaching as far back as the Renaissance, they contend Andreas Vesalius' *De Humani Corporis Fabrica* (1543 C.E.) "is the founding *text* of scientific anatomy, but its popularity and impact...was due to the exquisite dissection imagery" (2008: 4). Indeed, visual perception in science, they continue, has an incredibly long history, and been used in many ways, including metaphorically—"the mind's eye."²⁸ Whatever the case, their premise is that to *visualize*, whether that be an image before the "mind's eye," the physiological eye, or both, is inherently connected to making the world "intelligible." What that might mean is not explored at any length—and will be analyzed with more precision below— but for them it is related to the *physiological* fact that the cortex of the brain is devoted to higher brain functions, and a "surprisingly large portion—40%—of the cerebral cortex is devoted to vision" (5). Visual perception, they contend, is high-speed "pattern recognizer," which resembles a supercomputer behind our eyes (again, another computational argument) that we require to make the world

²⁷ See Richard Doyle, *On Beyond Living: Rhetorical Transformations in the Life Sciences*.

²⁸ See Evelyn Fox Keller and Christine R. Grontkowski's article, "The Mind's Eye," for a careful genealogy of visual perception's privilege in scientific epistemology.

intelligible, but very rarely acknowledge. This supercomputer power of visual perception is what scientific visualization seeks to “harness” (*sic*).

Given these two assumptions, what makes 3D animation the privileged medium of scientific visualization? Their argument is that computer animation, especially using the high-end computer-animation software program, Maya Autodesk, brings computational biology and visual perception together as they have never been before. What makes Maya unique among the other simulation software, or in any case, a highly desirable visualization package, is the combination of Maya’s scripting language, MEL, and the suite of visualization tools (which also allow for a high degree of control over cameras, lights, textures in the final rendering). Indeed, at the heart of this programming language, MEL, is math (like most other programming languages). What this means for a visualization suite, however, is that mathematical structures, of almost any form, can be translated into 3D visual form, thus increasing the intelligibility of those structures (or so the computational argument goes). Thus, “just about any structure or process,” they go onto argue,

that can be described mathematically—from simple molecular diffusion to a complex AI scenario—can be expressed using MEL. This means that, in addition to employing Maya’s built-in physics capabilities, you can program the rules of cell activity relevant to a specific project, in essence writing your own *in silico* biology engine. Parameters and equations then can be adjusted to test hypotheses or to make predictions *in silico* in advance of expensive, time consuming real-world experimental work (17).

For Sharpe and his colleagues, Maya combines the most sophisticated computational biology with the most cutting edge visualization techniques (the very same software used in films like *Jurassic Park*, *Spiderman*, *Star Wars*, *Episode II: Attack of the Clones*, and *The Lord of the Rings: The Two Towers*) to render mathematical entities visible, and thus more intelligible to scientists. Stunning molecular animations are not mere biological fantasy worlds (as many contend—see below); rather, they fundamentally index what is mathematically known about

molecular structures and processes, and are even able to experiment on that knowledge base. In other words, animation provides a perfectly legitimate way to conduct *in silico* biology—simulation, experiment, and predictive modeling—with the added, epistemological advantage of being able to do it in space and time.

Before I go onto to review criticisms of molecular animation, I want to draw attention to a point that will figure prominently later in the chapter. What remains wholly unanalyzed in Sharpe and colleague's work is that scientist-animators are working on proprietary software—and Maya, specifically. Now, their justification for this choice is that Maya in particular provides a unique combination of mathematics and visualization tools, which gives scientists the ability to have multiple views of a molecular process. Different lighting and shading, for instance, might reveal something otherwise unnoticed. Likewise a flythrough may reveal aspects of a molecular system that a cross section is unable to express. In other words, this software provides scientists a kind of flexibility that is impossible with other visualization suites.

Whether that is completely true, I'm not at liberty to say here (although I have my reservations, given Graham Johnson's work on automation using Maxon's Cinema 4D program—see below). What worries me, though, is that the kind of visual flexibility afforded to scientists using proprietary software is also, in large part, conducted in the animation studios of privately owned biological graphics companies. Jason Sharpe, like Gael McGill, is a “scientist-entrepreneur.” Sharpe is President and Founder of AXS Studio, a visualization company that provides animations for “pharmaceutical, biotechnology, and medical device companies” (<http://www.axs3d.com/index.php>). And Gael McGill, for his part, is President and CEO of Digizyme, a competing scientific animation company (<http://www.digizyme.com/index.html>). Two of the most prominent scientist-animators also have large stakes in companies. The point here

is that the incredible flexibility animation offers scientists, is increasingly circumscribed by the interests of competitive markets. Market interests underwrite the production of novel views of molecular processes. In short, animate flexibility is inseparable from institutional practices governed by the competition of neoliberalized markets. While these are concerns that I return to in more depth below, for now it's sufficient to flag them as an aspect of molecular animation that eludes both supporters and critics alike.

Instead, what critics of the technology tend to focus on is the seductive character of their visual representations. In this way, many of skeptics of computer animation do not resort to arguments about “accuracy,” that is, the molecular world does not *actually* look that way—indeed, scientists are well aware that models are not the real thing (see Tami I. Spector's work above)—but on the inherent confusion that issues from presenting a fantasy of biology that is *too* convincing.²⁹ Although most biologists will agree that 3D animation is pedagogically valuable, and may even revolutionize how scientists communicate information to the uninitiated—E.O. Wilson, for example, recently co-authored the textbook, *Life on Earth*, which was animated by Digizyme³⁰—the real danger of molecular animation (which in some ways sets them apart from other forms of imaging), is that it's incredibly seductive: not only are they highly stylized, but they can also be incredibly convincing.³¹ The molecular world comes “alive” for the spectator; it unfolds in time and in the context of the atomic and cellular scales that scientists know mathematically but have yet to see in action—until now. Some critics argue that this can lead not

²⁹ See UCSF scientist Peter Walter's criticism of the technology in the Erik Olson's *New York Times* article, “Where Cinema and Biology Meet.” In some ways, this criticism parallels the anxiety scientists feel over other forms of 3D modeling in biology. In her work, *Simulation and its Discontents*, Sherry Turkle interviews a number of structural biologists who remain skeptical of 3D models, mostly because scientists are seduced by the models, and tend to treat what they're seeing *as* the real thing. In other words, computer graphics are *too* good. See Turkle 2009: 60-65.

³⁰ <https://itunes.apple.com/us/book/e.-o.-wilsons-life-on-earth/id529004239?mt=13>

³¹ In her article, “Animating the Model Figure,” Janet Iwasa shows how she and her team had to redo an molecular animation because it was too realistic, and it led viewers to believe that the model was based upon what scientists had already agreed on. I discuss this in the Conclusion.

only to public but also to scientific misconception. Scientists may come to believe what they're seeing, or at the very least, rely too heavily on the fantasy world created by biologists teaming up with Pixar and DreamWorks animators. In this way, critics of animation do not so much object to modeling molecular processes per se—it's hard to find working biologists today who don't rely on computer models of some kind—rather they object to the way it they are modeled, to the fact that animation seduces viewers into believing that what they're seeing is the real thing.

One of the central concerns of this chapter will be to account for why animation has become not just popular in some scientific communities, but a sign of the new regime of scientific visibility, soon to leave its detractors behind. In many ways, then, I agree with what Sharpe, Lumsden, and Woolridge contend about the legitimacy of the technology for scientific visualization. And what's more, I even side with their claim that the technology excels at visual *representation*. But what I disagree with—and this is a big disagreement—is their insistence that the technology indexes the steady march of scientific progress. Rather, what this chapter endeavors to explain is the general epistemic shift that was necessary for the convergence between bioinformatics and the cinema to be valuable to scientists. My contention is that it is a shift in political and economic circuits of power that makes this possible.

To explain this shift, I will draw on an unlikely source: Gilles Deleuze's short essay from 1990 titled, "Postscript on Control Societies." This choice may come as surprise for a variety of reasons. For one thing, why invoke a broad theory of political and economic change—and an unfinished theory at that—to understand a transformation in value within a small scientific community? Add to this, Deleuze's political work is most often associated with his collaborative efforts on the two volumes of *Capitalism and Schizophrenia* with Félix Guattari. And to be sure,

this collaboration has received no shortage of criticism for its abstract method and content.³² So why think that this short essay, which Deleuze wrote alone, and at the end of his life, could offer us anything more concrete?

To address these questions, it's important to recognize what Deleuze's brief essay can and cannot do for us. First, I will argue that the "Postscript" makes a general shift in political power explicit. It demonstrates how Michel Foucault's disciplinary regime has come to a close, and that a "new monster" has arrived, which precipitates what William S. Burroughs calls "control." Control societies, Deleuze maintains, operate by means of "information technology and computers," a "technological development," which he insists, "is more deeply rooted in a mutation of capitalism" (Deleuze 1995: 180). Many scholars have noted that this "mutation in capitalism" closely parallels what Foucault calls "neoliberal governmentality" in his 1978-1979 lectures at the Collège de France, *The Birth of Biopolitics* (2008).³³

Of course Deleuze's reflections on control societies did not take hold in the critical discourse on capitalism the way that Foucault's neoliberal governmentality or Fredric Jameson's postmodern or late capitalism did. This is in part due to the fact Deleuze's work on control is incredibly thin when compared to Foucault's and Jameson's. Recently, however, scholars have begun to look outside of the narrow confines of his short essay and assess whether his earlier

³² See Gregg Lambert, *Who's Afraid of Deleuze and Guattari?*

³³ In this lecture course, Foucault gives voice to the fact that the "logic of exchange" that defined the classical liberalism of Adam Smith has been replaced by a new logic: "a shift from exchange to competition in the principle of the market. . . the most important thing about the market is competition, that is to say, not equivalence but on the contrary inequality . . . competition, and only competition, can ensure economic rationality" (Foucault 2008: 118-119). For neoliberals, political economy is not simply one dimension of a wider social field, but subsumes all aspects of social life: there is a "generalization," Foucault explains, "of the economic form of the market. It involves generalizing it throughout the social body and including the whole of the social system not usually conducted through or sanctioned by monetary exchanges" (243). Deleuze is certainly aware of this generalization in the "Postscript." His wager is that society at large, from corporations and institutions to sports, television shows, and domestic space, is abstracted into data that is managed according to this insidious post-disciplinary rationalism. See Wendy Brown, "Neoliberalism and the End of Liberal Democracy," for a cogent account for neoliberal rationality. Also see Thomas Lemke's "'The Birth of Bio-politics': Michel Foucault's Lecture at the Collège de France on Neoliberal Governmentality."

work—his book on Foucault, for example—anticipates his reflections on control, and thus gives us a more robust and complete picture of this new society. This research opens up a startling number of questions without clear answers. For example, what is the real target of his critique? Is Deleuze finally revealing his true “Marxist” stripes here, as Steven Shaviro has proposed?³⁴ Or is the real source of his worry the “computer age,” as Alexander Galloway suggests after pouring over Deleuze’s earlier mediations on digitization?³⁵ Or again, is he meditating on the emergence of something like neoliberal biopower, which extends work that he began four years earlier in *Foucault*, and is fleshed out by Michael Hardt and Antonio Negri?³⁶ In the end, what is being asked is whether Deleuze’s reflections on control have any critical purchase in the twenty-first century.

These questions lead me to my second argument, which is that the “Postscript” is indeed relevant for understanding the appeal of molecular animation, inasmuch as it helps clarify the technical and epistemic transformation that has taken place in biological data visualization. I demonstrate how this clarification is not contained in the pages of Deleuze’s short text per se, and argue that it unfolds in the “Postscript’s” relation to earlier writings and in its anticipation of general shifts in value. To show this, I first contextualize Deleuze’s reflections on the technical and economic transformations that he sees occurring at the close of the twentieth century. This will allow me to argue that Deleuze anticipated his reflections on control in earlier texts where he worries about the effects of third-generation or cybernetic machines on two domains that were incredibly important to him: the cinema and the sciences of life. I discuss how just a few years prior to the publication of the “Postscript,” Deleuze expressed concerns about the fact that life and

³⁴ See Steven Shaviro, “The ‘Bitter Necessity’ of Debt: Neoliberal Finance and the Society of Control.”

³⁵ See Alexander Galloway, “Computers and the Superfold.”

³⁶ See Michael Hardt and Antonio Negri, *Empire*.

the moving image would be taken over by cybernetic machines. I argue that what may at first seem like disconnected reflections on the state of technology in biology and the cinema in the 1980s, actually anticipate, in crucial ways, not only his meditation on control a few years later, but also the conditions for a convergence between the cinema and biology that is taking shape in biology today in the form of molecular animation.

My argument is not limited to pointing out that Deleuze somehow foresaw a *technical* mutation in the cinema and biology, however, which would one day lead to their convergence in molecular animation. Much more than this, I'm interested in how these early reflections on the control over biological life and the moving image help us understand why, precisely, their conjunction would be valuable to scientists today. Ultimately, I argue that Deleuze gives us the tools to explain the kind of society that would value a technical convergence that threatens to eclipse both biological *life* and cinematic *time*. Along the way, I demonstrate how a reconsideration of control intervenes in long-standing debates within science and technology studies (STS) over the production of value within scientific practice (with particular attention paid to Lorraine Daston and Peter Galison's work), and sharpens our awareness of how data is *representationally* tied to visual information (which Alexander Galloway and other critical media theorists explore) in the age of digital science.

On the one hand, this investigation will leave us with a tighter grasp of how computer animation is indeed representational, and in this way it will help clarify how animation continues the long history visual representation in science. But much more than this, the analysis dispels the myth that animation's representations are the "neutral" mark of progress (*pace* Sharpe and his colleagues), and intervenes by demonstrating how they are controlled by the insidious logic of neoliberal value production. This will leave us, on the other hand, asking whether there is a model

of non-representational scientific visuality to draw from that could (1) help interrupt this political and economic control of the image, and (2) allow us to imagine a new kind of visual science. This will require us to ask some pressing questions: How firmly ingrained is the norm of representation within scientific epistemology? And have there been instances within the history of scientific visuality that have disrupted representation's firm grip? And if so, how were these instances received within the scientific community? And then finally, what does this mean for the future of molecular animation? Can there be a non-representational molecular animation that is valued scientifically? Will neoliberalized technoscience tolerate this?

These are just some of the questions that will occupy me in the remaining chapters of this work. It is with this in mind that I now turn to Deleuze's "Postscript."

1.2 Digital Capital

I want to start by characterizing what may be perceived as a tension between the technological and the economic dimensions of Deleuze's work on post-disciplinary societies. Relieving this tension is important for framing his reflections on biological life and the moving image in the computer age in the 1980s. There is a sense in which Deleuze's sobering meditation on digitization in the "Postscript" may come as a surprise. Despite his skepticism in the "Postscript," as well as a few other places, Deleuze is often regarded as an important thinker of digital culture. Indeed, his work has been inspiration for the for theories of Internet connectivity (see Stivale 1998; Savat and Poster 2012), folding architecture (see Lynn 1999; Frichot and Loo 2013), the digital baroque (see Murray 2008; Munster 2006), and even neuro-digital culture (see Connolly 2002; Pisters 2012)? And, yet, the Deleuze of the "Postscript" seems deeply skeptical about all forms of digital culture, or in any

case, expresses serious reservations about “third-generation machines,” and even seems to find a new, if unspoken enemy: namely, Norbert Wiener and twentieth-century cybernetics.³⁷

Of course one could reasonably object to this characterization, and insist that this is not the whole story: Doesn't Deleuze explicitly state in the “Postscript” that “machines don't explain anything” (Deleuze 1995: 180), and that their explanation resides in the “collective assemblage” to which they belong? Hence, digital technologies are “more deeply rooted in a mutation of capitalism” (ibid.). Deleuze even reinforces this view in a late interview where he confesses that, “the article I published on the ‘society of control,’ for example, is completely Marxist, even though I am writing on things that Marx knew nothing about” (Deleuze 1995a: 51).³⁸

But then what are we to do with Deleuze's criticisms of digital technologies in earlier texts, where he demonstrates his rather explicit preference for the analogue? For example, Alexander Galloway contends that Deleuze's real target in the “Postscript” is the computer.³⁹ To support his

³⁷ In his article, “Computers and the Superfold,” Galloway contends that Deleuze's real source for the concept of “control” is Norbert Wiener's 1948 work, “Cybernetics: or Control and Communication in the Animal and the Machine.”

³⁸ It is well known that Deleuze's and Deleuze-Guattari's relation to Marx and Marxism is a complicated one, and that in their two volumes of *Capitalism and Schizophrenia* they make important revisions to Marx, especially to the latter's notion of production. In particular, they reject “dialectics” (as this is a form of identity that cannot account for difference). They also argue that desire is what is truly productive, so that “modes of production” are actually expressions of a more primary desire. And finally, this latter revision means that there is no longer a “base” and “superstructure” relation as there is in Marxist thought, since modes of production (the base) are just as much expressions of desire—or what is truly productive—as any other forms of expression. See Eugene Holland, *Deleuze and Guattari's Anti-Oedipus: Introduction to Schizoanalysis*, for an insightful analysis of how Deleuze and Guattari update Marx, and Gregg Lambert, *Who's Afraid of Deleuze and Guattari*, for a thorough explication of Deleuze and Guattari's notion of desire. Crucially, however, Deleuze's association with Marx and Marxism does not stop at the two volumes of *Capitalism and Schizophrenia*. Deleuze became acquainted with Antonio Negri and the Italian workerism movement (*operaismo*) of the 1970s through Guattari, and indeed many of Deleuze's insights on immanence and Spinoza are detectable in Negri's work in the 1980s (especially in *The Savage Anomaly*), though they become pronounced in the latter's collaboration with Michael Hardt in their 2000 work, *Empire*. Thus, Deleuze's remarks regarding his fidelity to Marx (which were published posthumously) must be taken in the context of both his growing concern over millennial capitalism and his familiarity with Italian Marxism(s). In fact, Deleuze is said to have been working on a manuscript at the time of his death titled, *Grandeur de Marx*. See Nicholas Thoburn, *Deleuze, Marx, and Politics*.

³⁹ Galloway provocatively asserts that, “[t]he crux of this short text has to do with technology. For here is one of those rare moments in which Deleuze comments on actually existing contemporary technology, specifically computers” (Galloway 2012a: 517).

case, Galloway draws on two earlier works in which Deleuze explicitly privileges the analogue over the digital. In *Francis Bacon* Deleuze writes that “digital synthesizers are ‘integral’: their operation passes through a codification, through a homogenization and binarization of the data” (Deleuze 2003: 95). To say that the digital is “integral,” is of course a reference to mathematics, in which to integrate a mathematical function means summing the area under the curve defined by $f(x)$; but it is also, and relatedly, a reference to Deleuze’s work from 1968, *Difference and Repetition*, where he writes that “four terms are synonymous: actualize, differentiate, integrate and solve” (Deleuze 1994: 211). His remarks about the digital in his Bacon book are thus a loosely veiled reference, Galloway contends, to the fact that digitization operates by integrating or *actualizing* heterogeneous elements into “homogeneous regularities of aggregation” (Galloway 2012a: 518); the digital coordinates and organizes for Deleuze, just as actualization does. And then to round things out, Deleuze tells us, also in *Francis Bacon*, that “analogical language [is a] language of relations, which consists of expressive movements, paralinguistic signs, breaths and screams “(2003: 93). And “analogical synthesizers,” he continues, “establish an immediate connection between heterogeneous elements,” which is what makes painting “the analogical art par excellence”(91).

Given these remarks, it’s hard to deny that Deleuze is hesitant to embrace digital technologies, and that he may even be, as Galloway insists, *the* premier philosopher of the analogue (see 2012a: 521). In other words, Deleuze appears to have genuine reservations about the logic of the digital, which aren’t ultimately based upon economic ones— or economics “in the last instance.” If anything, his concerns seem to be more ontological than they are economic: where the digital tends to homogenize the world into code, the analogue preserves the world’s

heterogeneity, allowing its elements to penetrate and contaminate one another without them losing their singularity.⁴⁰

Even so, I think it would be a complete mistake to abstract out the economic dimensions from Deleuze's misgivings about digital computation, simply because the former does not figure into his earlier texts per se—or because his emphasis seems to be more ontological than economic. The distinct advantage of hindsight in this instance is that we now know that Deleuze firmly believes that technologies do not operate in isolation from the societies to which they belong and make them possible. We only need to recall Deleuze's crucial remarks in the "Postscript": "it's easy to set up a correspondence between any society and some kind of machine, which isn't to say that their machines determine different kinds of society but that they express the social forms capable of producing them and making use of them" (Deleuze 1995:180). And the society that Deleuze has in mind in the "Postscript" is a society very similar to the neoliberal one that Foucault discusses in *The Birth of Biopolitics*.⁴¹ The advent of digital technology, Deleuze insists, is "more deeply rooted in a mutation of capitalism" (180). He thus speaks with understandable distain about the post-disciplinary collapse of the welfare state, the erosion of public institutions, and the logic of market competition extending to all aspects of social life, and perfectly expressed in "the stupidest TV game shows," which he claims are the "perfect reflection of the way businesses are run" (179). The capitalism that worries Deleuze in the closing decade of the twentieth century is

⁴⁰ Galloway draws on Deleuze and Guattari's famous example of the wasp and the orchid from *A Thousand Plateaus* to demonstrate the ontological dimensions of the analogue: [i]n the analogue paradigm, the stuff of the world remains unaligned, idiosyncratic, singular...Deleuze's famous example is the wasp and the orchid, two creatures, alike in almost no sense, that nevertheless couple up analogically. Although they are two, at the point of coupling the wasp and the orchid merge into one" (Galloway 2012a: 520).

⁴¹ Gregory Flaxman has recently suggested in unpublished work that despite Deleuze's closeness to Foucault's reflections on neoliberal governmentality, Foucault's later reflections on governmentality and the care of the self struck Deleuze as perhaps *too neoliberal*. Jeffrey Nealon, however, has done important work to correct the assumption that Foucault's later work on the care of the self is indeed neoliberal. See Jeffrey Nealon, *Foucault Beyond Foucault: Power and Its Intensifications Since 1984*.

not the same capitalism that worried him in *Anti-Oedipus* in 1972. This millennial capitalism is “the beginning of something new” (182), Deleuze reminds us, and it involves both the generalization of market rationalism “throughout the social body and including the whole of the social system” (Foucault 2008: 243), and the creation and utilization of cybernetic machines to extend its reaches into domains that were previously thought to be outside the grasp of capital.⁴²

My suggestion, then, is that we do not blame either the economic or the digital in the “Postscript,” but that we proceed by recognizing that Deleuze’s reproach of third-generation machines (throughout his work) is, in some fundamental sense, also an articulation of how those machines lend themselves to being produced and seized by a particular form of economic rationality—a conjunction which is only really spelled out in his later reflections in the “Postscript.” While it is true for Deleuze that “machines don’t explain anything”—and that technical materials are open (if virtually) to other forms of social organization (something that Bernard Stiegler also appreciates about the digital⁴³)—cybernetic machines are nonetheless vulnerable to being captured by this pervasive form of market rationalism that leaves nothing behind (from affect to geologic processes), precisely because they homogenize the heterogeneous; they level down the world of analogue heterogeneities into abstract code. This is the spirit with which I think we should approach Deleuze’s fear in two earlier works that “life” and the “cinematic image” are transformed in the computer age.

⁴² See Maurizio Lazzarato, “Immaterial Labor” for a clear and succinct account of the new modes of production under neoliberal capitalism. Also see Michael Hardt and Antonio Negri’s account of immaterial labor in *Empire*, 293.

⁴³ See Bernard Stiegler, *For A New Critique of Political Economy*.

1.3 Life and Time Under the Control of Cybernetic Machines

But if Deleuze worries about the transformation of life under the control of cybernetic machines—as I will claim below—why does he not also credit Foucault with having discovered the modern category of power that is devoted to regulating life according to abstract calculations: namely, biopower? Though Deleuze credits Foucault with having discovered disciplinary societies in the eighteenth and nineteenth centuries, it is Burroughs, and not Foucault, who he credits with grasping the logic of post-disciplinary societies. And yet don't the concepts of biopower and biopolitics provide two of the most important theoretical frameworks for understanding the subtle distributions of power over life in the contemporary world? Is this a gross oversight on Deleuze's part?

Some critics have noted that biopolitics actually plays a relatively small role in Foucault's oeuvre,⁴⁴ and that the lecture course he devoted to the topic in 1978 and 1979 (*The Birth of Biopolitics*) never really got around to discussing it; instead, it focused on liberal and neoliberal forms of governmentality (see Paul Patton 2012).⁴⁵ Does this explain its absence from Deleuze's text? And, yet, Foucault justifies this reframing at the end of the first lecture by telling us that the “liberal art of government” forms the backdrop so that “something like biopolitics could be formed” (Foucault 2008: 21).⁴⁶ Deleuze, for his part, does not overlook biopower in his book on Foucault four years prior to the publication of the “Postscript.” There, in a brief but memorable

⁴⁴ References to the concepts of biopower and biopolitics appear at the end of *The History of Sexuality: An Introduction Vol. 1* and at the end of his 1975-1976 lecture course, *Society Must Be Defended*. They are also referenced in relation mechanisms of security in Foucault's 1977-1978 lecture course, *Security, Territory, Population*. And then finally, biopower and biopolitics appear in his lecture course from 1978-1979 that are devoted to the topic, *The Birth of Biopolitics*, but they are not fleshed out there either.

⁴⁵ See Paul Patton's unpublished work, “Life, Legitimation and Government,” collected in the proceedings for the “Society for the Study of Bio-political Futures,” 2013: <http://www.biopoliticalfutures.net/ssbf-events/ssbf-syracuse-2>

⁴⁶ See Jeffery Nealon, *Foucault Beyond Foucault: Power and Its Intensifications Since 1984*.

passage, Deleuze succinctly formulates the means for resisting biopower: “Life becomes resistance to power when power takes life as its object,” and thus

[w]hen power becomes bio-power resistance becomes the power of life, a vital power that cannot be confined within species, environment or the paths of a particular diagram. Is not the force that comes from outside a certain idea of Life, a certain vitalism, in which Foucault’s thought culminates? (Deleuze 1988: 92-93).

My argument here is not so much that there is a shift away from biopower and biopolitics in Deleuze’s later work, but it is rather that he, like Foucault, is concerned with the formative conditions of biopower/biopolitics, and thus Life-resistance, under conditions of millennial capitalism. And for Deleuze, life at the end of the twentieth century is controlled by the flexibility and competition of a market logic, which eclipses the role of the state in regulating life (or in any case, the state’s primary function is to serve the free market), and which uses digital technologies to ensure that all aspects of life are regulated according to this logic..⁴⁷ But make no mistake, this is not life under the control of central regulatory agency. On the contrary, the control of life is fundamentally dispersed and distributed across the post-human flows of neoliberal value production, and which strengthen themselves the openness to novel combinations, new territories, and thus new markets. In the language of Deleuze and Guattari, control is deterritorialized.⁴⁸

It is this configuration of biopower—or “neoliberal biopower”—that preoccupies Deleuze when he offers these few thoughts in the appendix to *Foucault* about what had to happen for this new vision of cybernetic life to be born:

Biology had to take a leap into molecular biology, or dispersed life regroup in the genetic code. Dispersed work had to regroup in third generation machines, cybernetics and

⁴⁷ This new form of biopower is spelled out by Hardt and Negri in *Empire*. There, they argue that Empire is a “regime of biopower” (Hardt and Negri 2000: 41). For them, biopolitical production undermines the differences between economics and politics such that biopolitics is a new mode of capitalist production. Furthermore, “biopolitical production” signals a new relation between “nature” and “culture,” such that “nature,” which was previously outside of production, is now internal to it: life “has become capital, or at least has become subject to capital” (187).

⁴⁸ See Hardt and Negri, *Empire*.

information technology. What would be the forces in play, with which the forces within man would then enter into a relation? It would no longer involve raising to infinity or finitude but an unlimited finity, thereby evoking every situation of force in which a finite number of components yields a practically unlimited diversity of combinations. It would be neither the fold or the unfold that would constitute the active mechanism, but something like the *Superfold* as borne out of the foldings proper to the genetic code, and the potential of silicon in third-generation machines... (1988: 131).

If the “fold” is how Deleuze characterizes the “active mechanism” of the modern subject,⁴⁹ then the “superfold” is how he characterizes the active mechanism of cybernetic life. And insofar as the superfold, which Deleuze unfortunately says very little about, is “proper to the genetic code,” and “yields a practically unlimited diversity of combinations” out of its finite components, then this is because the superfold characterizes the diagram proper to the potential for endless recombination that results when the “forces within man enter into forces from the outside, those of silicon which supersedes carbon, or genetic components which supersedes the organism...” (1988: 131-132). In other words, the superfold is the diagram proper to the conjunction of biology and informatics: bioinformatics.⁵⁰

But if Deleuze ends *Foucault* with a somewhat ambivalent attitude toward this new form of cybernetic life, hoping that it will “not prove worse than its two previous forms” (1988: 132), rest assured that only four years later in an interview with Antonio Negri, he laments that it is a form of life that “ought to make us shudder” (Deleuze 1995b: 175). The double helix, which Deleuze calls the “best known example of the superfold,” yields recombinant *dividuals*, which form and reform themselves endlessly, optimizing life’s code, across a bioinformatic landscape.

⁴⁹ See Deleuze, *The Fold: Leibniz and the Baroque*. Also see Timothy Murray’s excellent work, *Digital Baroque: New Media Art and Cinematic Folds*, for a thorough treatment of how nonlinear temporal folds inform contemporary screen arts. Also see Gregg Lambert’s examination of the baroque in *The Return of the Baroque in Modern Culture*.

⁵⁰ Please see Galloway’s description of the “superfold” in “Computers and the Superfold,” and in particular his invocation of bioinformatics.

This is not unlike the situation that Deleuze thinks Kafka expresses in *The Trial*: the subject experiences *endless postponements*—the ultimate judgment is postponed indefinitely.⁵¹ Similarly, there is no outside or beyond to informatic life: the reformation and re-optimization of life can go on indefinitely, without end, from finite bits of data. My sense is that the conjunction of biology and informatics worries Deleuze, both because it enables the subtle workings of control to be administered all the way down to the organism’s molecule structure, leaving no aspect of biological life out of the hands of control, and more generally, because such organismic control “is that which life sets against itself in order to limit itself”(Deleuze and Guattari 1987: 503). The real issue here in any case is that it seems unclear to Deleuze by the time he writes the “Postscript,” how a “vital outside,” which is the basis for resisting modern biopower, and is so central to his other work (variously termed “a Life,” “indefinite life,” “nonorganic life”⁵²), can be forged at the end of the twentieth century. Thus, if there is an air of deep pessimism that hangs over Deleuze’s late reflections on control that doesn’t seem to weigh on his other work on political power, this is perhaps because he wasn’t yet able to imagine how a Life is possible under conditions of millennial capitalism.⁵³

⁵¹ Deleuze explains that “Kafka, already standing at the point of transition between the two kinds of society, described in *The Trial* their most ominous judicial expressions: *apparent acquittal* (between two confinements) in disciplinary societies, and *endless postponement* in (constantly changing) control societies are two very different ways of doing things, and if our legal system is tottering, is itself breaking down, it’s because we’re going from one to the other” (Deleuze 1995: 179).

⁵² Please see my essay, “Imaginative Chemistry: Synthetic Ecologies and the Construction of Life,” for a more thorough consideration of the significance of Life in Deleuze and Deleuze and Guattari’s philosophy. Also see John Protevi’s essay, “Deleuze and Life,” for a detailed explication how the concept of Life undergoes many transformations in Deleuze and Deleuze and Guattari’s work.

⁵³ Hardt and Negri have of course made the strongest case for the affirmative potentials of Life-resistance against capital’s subsumption of all of society. They explain that “Empire creates a greater potential for revolution than did the modern regimes of power because it presents us, alongside the machine of command, with an alternative: the set of all the exploited and the subjugated, a multitude that is directly opposed to Empire, with no mediation between them” (Hardt and Negri 2000: 393). With the concept of the multitude, which represents the revolutionary potential for new forms of life and work that are generated from *within* globalized biopolitical production, Hardt and Negri discover a *biopolitics* to resist *biopower*, which is heavily indebted to, if not wholly dependent upon, Deleuze’s notion of immanence and life. And yet it is precisely this reliance, which Thomas Lemke has argued, that reveals the greatest weakness of their revolutionary ambitions, inasmuch as Life seems to function “as an original and transhistorical entity” that “breaks with immanence” (Lemke 2011: 74). This ontological understanding of the

If Deleuze worries about the future of Life under the control of cybernetic machines, then he worries just as much about the future of the privileged medium for expressing time: the cinema. In the Conclusion to *Cinema 2*, Deleuze ponders the new regime of images that are born out of the “new computer and cybernetic race,” the “automata of computation and thought... of controls and feedback” (Deleuze 1989: 264-265). In the world of 1985 when screens were just beginning to proliferate, Deleuze voices his concern over the loss of the “outside” in the age of digital images:

The new images no longer have any outside (out-of-field), any more than they are internalized in a whole; rather, they have a right side and a reverse, reversible and non-superimposable, like a power to turn back on themselves. They are the object of a perpetual reorganization, in which a new image can arise from any point whatever of the preceding image... And the screen itself, even if it keeps a vertical position by convention, no longer seems to refer to the human posture, like a window or a painting, but rather constitutes a table of information, an opaque surface on which are inscribed “data,” information replacing nature, and the brain-city, the third eye, replacing the eyes of nature. (265)

Read alongside Deleuze’s reflections in *Foucault* and the “Postscript,” this passage amply demonstrates how the image and the gene are subjected to parallel recombinant logics, to the same potential for an “unlimited diversity of combinations.” Put another way, the differences between the image and the organism are rendered inessential in the age of cybernetic machines. N. Katherine Hayles demonstrates this point vividly when she argues that eradicating the essential differences between organism and machine, between organic and inorganic, was the goal of first-order cybernetics all along, which was largely made possible by Claude Shannon’s theory of information understood as a function of message probabilities abstracted from context and meaning.⁵⁴ In this view, machine and animal are both “cybernetic entities.” This cybernetic

biopolitical then “has the effect of depoliticizing their work, when they conceive of the multitude per se as an egalitarian and progressive force that is invested with a radical-democratic goal” (75).

⁵⁴ See N. Katherine Hayles’ seminal work, *How We Became Posthuman: Virtual Bodies in Cybernetics, Literature, and Informatics*, for her account of the Macy Conferences, as well as her cogent description of how the different waves of cybernetics dealt with pervasive distinctions between mind and body, subject and object, organic and inorganic, form and matter.

homogenization is, I imagine, what led Deleuze to characterize biology and the cinema in similar terms, though in different works from the same period.

But it seems to me that Deleuze's greatest cause for concern is this: insofar as any digital image, or more specifically, any numerical point comprising a digital image, can become a link to any other image, the cinema risks losing its singular capacity to express time, or to produce a "time-image." More precisely, the immediacy of the digital, its instantaneous link to any point whatsoever from any other point, is what robs digital images of their indeterminacy (Mark Hansen, for instance, claims that the digital image "*explodes* the frame"⁵⁵), and is what forecloses their potential to be open to unknown futures—or in other words, to have an "outside."⁵⁶ Without a disruption in the instantaneous and automatic linkage between images, or what Deleuze calls the "sensory-motor schema" in the cinema books,⁵⁷ there can be no future that isn't already contained in the present. And these are the ingredients of the "dogmatic image of thought" that Deleuze spent the majority of his career trying to overcome.⁵⁸

This isn't to say that Deleuze overlooks other potentials for the digital image. In fact, he calls upon artists to find "another will to art" that may discover "as yet unknown aspects of the time-image" (Deleuze 1989: 266).⁵⁹ Rather, Deleuze's concern in 1985—and arguably the situation has only gotten worse not better—is that our current understanding of the digital image facilitates the loss of the outside, the image's singular capacity to express time. It's not too much

⁵⁵ Mark Hansen argues that the "digital image *explodes* the frame" (Hansen 2004: 35), which means that the body becomes the new "enframer" of the image—it gives form to, or *in-forms*, information (10).

⁵⁶ In an insightful discussion of how the "outside" functions in Deleuze's work, Gregory Flaxman observes that for Deleuze "we can only wrestle with the problem of the future when we engage the emergence of the most exterior of forces. The future is outside, Deleuze says, but how do we think the Outside (*le Dehors*)" (Flaxman 2012: 295)?

⁵⁷ Deleuze borrows the concept of the sensory-motor schema from Henri Bergson. See *Cinema 1*, Chapter 4.

⁵⁸ See *Difference and Repetition*, chapter 3, and Gregg Lambert, *In Search of A New Image of Thought: Gilles Deleuze and Philosophical Expressionism*.

⁵⁹ There is important scholarship now that uses Deleuze's thought to find new modes of thinking about the digital. See especially, Timothy Murray, *Digital Baroque: New Media Art and Cinematic Folds*, and Patricia Pisters, *The Neuro-Image: A Deleuzian Film-Philosophy of Digital Screen Culture*.

of a stretch to see how the loss of time on screen, also points forward to Deleuze’s reflections in the “Postscript”: digital images become instruments of control, facilitating the smooth and instantaneous consumption of images—nothing is out of reach. And it just this loss of “time,” in which there is no future that is not already contained in the present, that Deleuze understood as early as 1985, and we now know has become a hallmark of critical theories of late or neoliberal capital.⁶⁰ Perhaps we should take Deleuze seriously when writes that, “the world ...looks like a bad film” (171).

1.4 Bad Films

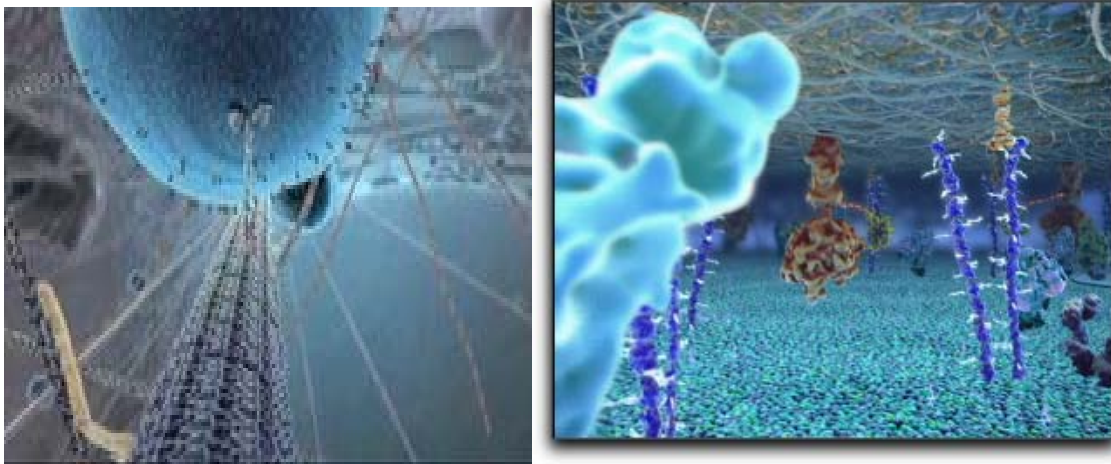

Figures 7&8: Taken from *The Inner Life of the Cell* (2006).

Now if the ever was a “bad film” according to Deleuze, it would have to be *The Inner Life of the Cell* (see above). What is intriguing about this film, and others like it, is that it links biology and

⁶⁰ See especially, Fredric Jameson, *Postmodernism, or, The Cultural Logic of Late Capitalism*; Franco “Bifo” Berardi, *After the Future*; Jonathan Crary, *24/7: Late Capitalism and the Ends of Sleep*; Jeffery Nealon, *Post-Postmodernism: or, The Cultural Logic of Just-in-Time Capitalism*; and Mark Fisher, *Ghosts of My Life: Writings on Depression, Hauntology, and Lost Futures*.

the cinema in an unparalleled way,⁶¹ and that moreover the seeds of this conjunction are already anticipated by Deleuze in the 1980s. Of course Deleuze could never have foreseen that Harvard biologists would team up with animators to produce a film like *The Inner Life of the Cell*, but the cybernetization of biology and the cinema that make such a configuration possible were already in the pages of his work. Thus, what Sharpe and his colleagues see happening in twenty-first century visual science, namely the coincidence of the digital image and gene via computation, in some ways only confirms Deleuze's earlier suspicions.

But the real point of this discussion is not to fixate on how Deleuze may have anticipated a technical convergence. We only need to recall his dictum that: "machines don't explain anything" (Deleuze 1995: 180). What's more interesting is the way in which his reflections on the cinema and biology flag the coming of a society in which such a convergence is not only possible but also *valued*. This is precisely the layer of analysis that current justifications for the technology do not—and maybe cannot—provide. What I will outline in the remaining sections of this chapter are the precise conditions under which such a technical convergence would be desirable in biological data visualization. I will then demonstrate how this is indicative of a more profound epistemic transformation in the biological sciences—indeed one that speaks to key debates in STS about the production of epistemic value within scientific practice.

Let me begin this discussion by reemphasizing that molecular animations, such as *The Inner Life of the Cell*, are still controversial within the biological sciences. As we noted above, there is a good deal of controversy surrounding whether computer animation is a viable medium for biological data visualization at all. Proponents of animation champion its ability to depict the

⁶¹ See Phillip Thurtle, "Animation and Vitality," for an excellent discussion of how molecular animation forges a connection between biology and the cinema.

dynamic context in which life at the molecular scale unfolds. As the scientist and animator, Janet Iwasa notes,

The use of 3D molecular models and animations can provide important insights into the structure/function relationship of a protein or protein complex. This is especially true of classes of molecules, such as motor proteins, where understanding a molecular mechanism is dependent on the ability to visualize movements in space and time (Iwasa 2010: 701).

Sharpe and his colleagues seem to make a similar claim in their textbook (although why, precisely, they may be in conflict will be noted at the end of the chapter). Indeed, they contend that biological data sets are so incredibly large, and reference phenomena at spatial and temporal scales that are impossible to see in the lab, that scientists now measure these structures numerically. This situation leaves scientists scrambling to invent new tool sets that can close the gap between the overabundance of esoteric data and meaningful form (Sharpe *et al.* 2008: 4). And molecular animation is just the visual tool (as we saw above) that is poised to close the so-called “knowledge gap” between data and meaning.⁶²

Despite the compelling case that Sharpe and others make for the scientific use of the technology, UCSF biologist, Peter Walter, explains, animations are “fantasies,” over-simplified abstractions or snapshots, which lure scientists into believing that they are the “real thing.” In this way, computer animations are troublemakers, inasmuch they seduce viewers into mistaking a mere copy for reality (we are not far from Plato here). And, yet, as we will see in this dissertation, this is certainly not a new criticism of visualization technologies in the biological sciences”, microscopy, chronophotography, cinematography, and computer modeling all experienced similar

⁶² McGill explains that, “the very same tools that were invented to animate a character like Shrek or Nemo are now being applied to set in motion protein domains and cellular processes. Although there is a disconnect between PDB files (and other data sets) and existing animation tools in molecular graphics packages, 3D animation software from Hollywood is poised to bridge that gap” (McGill 2008: 1129).

skepticism over the scientific value of their representations.⁶³ Does this mean that 3D animation, like the visual technologies that preceded it, will also gain acceptance within the scientific community?

Before we can adequately judge this, we need to first get clear on what both sides of this so-called debate do agree on: namely, that any visualization worthy of the name, “scientific,” must *represent* its data well. While proponents contend that computer animation marks significant progress in representing the dynamic movement of the molecular world; critics, meanwhile, object to its failure to flag its own representational character, that is to say, to express the fact that it is *merely* a copy or depiction of reality. And, yet, such “flagging” might inherently diminish what’s compelling about animation in the first place: namely, that it seems so “realistic.” What’s important to recognize here is that the epistemic value of a biological visualization (for both sides) is determined by its ability to adhere to the norms of visual representation in science. So what’s crucial to ask is what qualities or characteristics are being appealed to when each side of the debate claims to be adhering to representation? Or in other words: what characteristics must a biological visualization possess in order to be a valuable scientific representation? What is it that scientists value in their representations today?

In many ways, determining what scientists (from about the eighteenth century to the twenty-first century) have come to value in their visual representations of nature is the daunting question that Lorraine Daston and Peter Galison tackle in their 2007 book, *Objectivity*. One of their central concerns is derailing the common assumption that objectivity is synonymous with scientific modernity.⁶⁴ They argue that objectivity (specifically, mechanical and structural

⁶³ See Christopher Kelty and Hannah Landecker, “A Theory of Animation: Cells, L-Systems, and Film,” and Lisa Cartwright, *Screening the Body: Tracing Medicine’s Visual Culture*.

⁶⁴ What is remarkable about Daston and Galison’s lengthy study is that it unsettles the common assumption that objectivity is the sole “virtue” of scientific epistemology. In fact they go so far as to claim that the history of

objectivity⁶⁵) is one among other epistemic values or virtues in scientific epistemology,⁶⁶ and that each one (“truth-to-nature,” “objectivity,” and “trained judgment”) emerges as a shared value among “scientific subjects” that is supposed to guarantee nature’s most “faithful representation” (*sic.*). In this way, the virtues that legitimate scientific knowledge are inseparable from producing

objectivity parallels the way in which different moral virtues, such as “justice” and “benevolence,” “come to be accepted as such in different historical periods” (Daston and Galison 2007: 28). Their response to potential objectors is intriguing: to conflate objectivity and scientific epistemology tout court is imprecise and, moreover, shows little acuity for the subtle, but no less crucial, historical mutations of the working concepts of scientific practice. So for example, they explain that objectivity’s cognates in European languages come from the Latin, “obiectivus/obiective,” that were introduced by scholastics such as William of Ockham and Dun Scotus. Intriguingly, though, the term was “always paired with subiectivus/subiective, but the terms originally meant almost precisely the opposite of what they mean today. ‘Objective’ referred to things as they were presented to consciousness, whereas ‘subjective’ referred to things in themselves” (29). It was really Immanuel Kant, who, in launching his transcendental critique of reason, offers something like the germ of what we mean by “objectivity” today. But there again, Daston and Galison insist, what Kant means by “objective validity,” objektive Gultigkeit, does not yet refer to external reality, but to the a priori conditions of experience qua universal; whereas subjectivity refers to “empirical sensation” qua particular. The difference between subjective and objective had yet to correspond to the difference between mind and world. In fact, it was not until mid 1800s that dictionary entries began to define objectivity—though even in the 1863 a French dictionary still referred to it as the “new sense”—in the way that we understand the term today, that is, with reference to an “external object” (see 31).

⁶⁵ Mechanical objectivity emerged as an epistemic virtue, according to Daston and Galison, as response to the idealization of nature by scientists—the tendency to look past its imperfections to its “ideal form”—in their drawings. Photography, however, promised to *mechanically* reproduce nature without the intervention of human judgment. In short, the automation of image production in the sciences ensured that the self that flourished in the arts in the nineteenth century could no longer interfere with the reproduction of the physical world. To reproduce an object without the subject, or in any case, a subject who is self-restrained observer who modeled himself on the machine, this was the ideal of nineteenth century imagists. Mechanical objectivity was the highest virtue of scientific epistemology. However, many scientists grew weary of the limitations involved in mechanically reproducing the physical world through photographic images, and sought objectivity by other means. Hence, the emergence of the “structural objectivists,” or those scientists—among them were Frege, Pierce, Russell, Helmholtz, Carnap, Plank, and Poincare — whose confidence in gaining an objective understanding of the physical world never flinched, but who sought to acquire it without the aid of images, or any “empiricism” for that matter, claiming that these methods were still too subjective. Instead, “invariant structures” are what spurred research (see Daston and Galison 2007: 253-307).

⁶⁶ Their choice of the term “virtue” is interesting. While they suggest that the history of epistemic virtues parallels the history of moral virtues (see Daston and Galison 2007: 28), what’s more telling about their choice in term, “virtue,” is that each scientific value always produces corresponding subjectivities, “scientific selves.” For example, photography exposed not only nature as it is “in itself,” at least ideally, but also, and crucially, how previous epochs idealized nature, obscuring what was really there in favor of “all-too-human” visions of it. In this way, the culture of objectivity that began to flourish in the nineteenth-century sciences also, and simultaneously, disciplined the subject. “First and foremost, objectivity,” write Daston and Galison, “is the suppression of some aspect of the self, the countering of subjectivity. Objectivity and subjectivity define each other, like left and right or up and down... (36-37). In fact, the self that threatened scientific epistemology was the self cultivated and celebrated in “artistic” domains. Where previous eras, the Renaissance and Enlightenment, for example, made no firm distinctions between artistic and scientific practices, beginning in the nineteenth century their respective domains bifurcated. During this period, art needed to parade its subjectivity in order to be worthy of the name. The sciences, by contrast, did everything they possibly could to safeguard against the intrusion of this form of subjectivity. The photographic apparatus was technical site for ensuring that the subject’s desires were restrained; it disciplined a “scientific self.”

subjects shaped by those virtues—that is, “scientific selves” (see Daston and Galison 2007: 191-251). What’s crucial for us is that Daston and Galison’s empirical entry point into the shifting regimes of scientific epistemology is the construction and circulation of images for scientific atlases. They contend that atlas images “define the working objects of [scientific] disciplines ... They are the visual foundations upon which many observational disciplines rest. If atlases ground disciplines, epistemic virtues cut across them” (48). In other words, scientific image construction and circulation gives us privileged access into the shifting terrain of scientific epistemology.

It is important to point out that while Daston and Galison’s work is seminal for thinking foundationally about epistemic practices, it offers a more “internalist” history of science, in the sense that it is not overly concerned with how the values that take shape within the sciences might be thought of in terms of political and economic registers of value. Now, it may seem that I’m overstating the case a bit, especially since they look closely, for instance, at the role Kantian epistemology plays in the production of scientific subjectivity, the formation of artistic subjectivities in the nineteenth century, and even the emergence of the entrepreneurial scientist in the twenty-first century. These investigations, along with many others, are meant to tie scientific value production to wider social forces.

There are two things to note here. First, while Daston and Galison do draw on non-scientific sources throughout their text, the overwhelming majority of archival work comes from scientific archives. This is not ipso facto a problem, but it does generate a more inward-looking picture of scientific visual culture, especially when compared to Lisa Cartwright’s work, *Screening the Body: Tracing Medicine’s Visual Culture*, which deals with late-nineteenth and early-twentieth-century scientific visibility as well, but pulls from diverse sources (scientific, social scientific, political, artistic, etc.) to map the myriad ways in which disciplinary power shape the conditions for

knowledge production (more on this in Chapter 2). And second, Daston and Galison make no apologies for seeing real divisions between scientific culture and wider spheres of cultural production, especially in the nineteenth century. They even draw attention to their differences from Foucault, noting that the kind of subjectivities and knowledges constituted in nineteenth century science were “diametrically opposed” (*sic.*) to the ones constituted in other spheres, such as art and culture. Where Foucault sees deep continuity across nineteenth-century institutions and practices, Daston and Galison see real division (see Daston and Galison 2007: 199).

The point in bringing this up is to draw attention to the fact that although Daston and Galison’s work is crucial for thinking foundationally scientific visual culture, and epistemology more generally, it is largely insufficient when it comes to charting how scientific values are reflected in and constituted by wider spheres of political and economic value. This is in contrast to the way, for example, Steven Shapin and Simon Schaffer in their seminal, *Leviathan and the Air-Pump*, and more recently, Melinda Cooper and Kaushik Sunder Rajan straddle both epistemic and political-economic registers to account for the production of value and knowledge in scientific practice.⁶⁷

But even if Daston and Galison’s work does not deliver on everything, it is still *the* key text in the history of science for mapping the emergence of epistemic values/virtues in scientific visual culture. There is an important corollary to the history they reconstruct, however, and it is

⁶⁷ Quite obviously, all of these authors have very different stakes, and deal with different modalities of scientific practice and different moments in history. Shapin and Schaffer, for instance, are concerned with the emergence of the “experiment” as a guarantee of scientific knowledge. They are methodologically indebted to “social constructivism,” and are interested in the relation between knowledge and social order in seventeenth century Restoration England. Kaushik Sunder Rajan, for his part, investigates the global market of the postgenomic sciences, while Melinda Cooper is more interested in the co-emergence of biotechnology and neoliberalism in the late twentieth century. Rajan and Cooper both acknowledge the importance of forging a connection between Marx and Foucault in order to understand the emergence of the “bioeconomy.” What all three projects share, however, is a commitment to what might be called a “co-productionist” framework for understanding the relation between science and society. Also see the seminal collection of essays, *States of Knowledge: The Co-Production of Science and Social Order*, edited by Sheila Jasanoff.

one that I'm not even sure that they're aware of: namely, it is representation, instead of objectivity, that emerges as the mainstay of scientific epistemology. By the end of their lengthy work, they write that "truth-to-nature, objectivity, and trained judgment all have birth dates and biographies, yet these three virtues all served, each in its own way, a common goal: what we have called a faithful representation of nature" (2007: 381). In other words, representation undergoes many transformations in the history of science—as we will consider more closely in Chapter 2—but it remains, by and large, invariable—until the twenty-first century, that is.

In the twenty-first century, with the proliferation of digital images and the possibility of reality and image construction coinciding in practices such as nanomanipulation (using Scanning Tunneling Microscopy), "[i]n this corner of science," Daston and Galison insist, "the representation of the real—the use of images to finally get nature straight—may be coming to a close" (2007: 392). The reason for this shift away from representation is on the one hand technical (digital-image galleries, such as the Visible Human Project, and nanomanipulation both permit views of nature that have, in principle, never been seen before⁶⁸), and on the other hand political and economic, which opens their internalist history up to wider political and economic forces. They contend that the rise of the entrepreneur-scientist⁶⁹ has created an engineering-based ethos

⁶⁸ Daston and Galison explain that the Visible Human Project enables its viewers to manipulate images by "using the navigational and image-modifying capability of the program" so that they "can produce in a moment an image that no one had ever seen..." (Daston and Galison 2007: 390). What's even more game changing for scientific epistemology is that "nanomanipulative atlases," they contend, "aim not so much at depicting accurately that which 'naturally' exists, but rather at showing how nano-scale entities can be made, remade, cut, crossed, or activated. In the realm of nanomanipulation, images aren't examples of right depiction—but of objects that are being made, not found" (391).

⁶⁹ The wider political and economic conditions for the emergence of the entrepreneur-scientist are not spelled out in Daston and Galison's study (though do mention some institutional transitions). However, Cooper and Rajan, as well as Robert Mitchell in *Bioart and the Vitality of Media*, all attribute a great deal of weight to several important acts of legislation in the 1980s, such as the Bayh-Dole act in 1980, which "facilitated the transfer of technology between academe and industry and thereby enabled the rapid commercialization of basic research problems" (Rajan 2006: 6). Countless other events contributed to the emergence of neoliberalized technoscience, but the Bayh-Dole was a crucial piece of legislation that allowed research and business practices to overlap, and permitted scientists to become shareholders. See Mitchell's careful discussion of this legislation in *Bioart and the Vitality of Media*, 52-68.

among many scientists in which “[o]ntology is not much interest to” them since “they want to know what will work: what will function reliably under harsh conditions, what can be mass-produced—whether they are building airplanes, magnetic memories, or, increasingly, things in the nano-domain” (393).

But if there is increasingly a turn away from visualizing the world that “is,” and a turn toward visually constructing the world that “could be,” one can’t help but wonder why representation still has such a firm hold on the debates over the legitimacy of the growing field of molecular animation. After all, wouldn’t scientists working in this field be prime examples of those who fabricate molecular worlds that have never been seen before? And, yet, both sides of the debate remain committed to some form of visual representation. But if representation is epistemologically valuable to scientists, then what is meant by the term is much different from what it is commonly thought to designate: namely, the reproduction of an object, thing, or set of relationships that already exists. And it is indeed this reproductive view of representation that interest Daston and Galison. They write that “[r]epresentation is always an exercise in portraiture... The prefix *re-* is essential: images that strive for representation present again what already is. Representative images may purify, perfect, and smooth to get at being, at ‘what is’” (2007: 382). Thus, if representation still has a significant role to play in the scientific visual culture, then it has undergone significant transformation, indeed one that Daston and Galison aren’t able to capture in their definition.⁷⁰

My sense is that despite representation’s relative unpopularity in the last decade or so of STS research,⁷¹ that it still has an important role to play in our understanding of scientific practices

⁷⁰ Daston and Galison go so far as to argue that in this new epistemic regime images are no longer “competing with art,” as they were in the nineteenth century, “or even employing art but positioned as art itself” (2007: 384). In other words, seeing and fabricating the world have merged.

⁷¹ Admittedly, the concept of representation has a lot of theoretical baggage that has become unpopular in the last

in the digital age. The real issue, I believe, is that we still don't have a firm grasp on how to theorize the subtle transformations of visual representation in the age of digital science. For this reason, I follow Catelijne Coopmans, Janet Vertesi, Michael Lynch, and Steve Woolgar who point out in their introduction to *Representation in Scientific Practice Revisited* in 2014, that representation still remains as crucial as ever for STS research, it's just that we need to grapple with its complex transformation in an era where computer simulations, online databases, and share holders are as prevalent in biology labs as microscopes and petri dishes.⁷² So where Daston and Galison's more "internalist" study eventually has to look outward to wider regimes of political and economic value in late capitalism to explain the epistemic shift they see taking place in twenty-first century science, it still can't account for how and why representation continues to have a strong hold on data visualization practices such as molecular animation. This is where I think that critical studies of media and political economy can be of great assistance to us, mainly because they help account for the subtle permutations of representation in the age of data visualization and neoliberal capital. And it is here that Deleuze's reflections on control societies will become crucial.

In Alexander Galloway's 2012 work, *The Interface Effect*, he makes the compelling argument that in the age of data visualization and information design, we have lost the meaning of "data" and "information," or in any case, we've conflated the two, and use them interchangeably, when they are in fact separate. Where data denotes "the things that have been given," which is to say, numbers, pure mathematical values; information, on the other hand, designates the act of

decades of STS research. In *Representation in Scientific Practice Revisited*, Coopmans and her co-authors of the introduction claim there has been a general shift away from "representation" and an adoption of notions such as "mediation," "enactment," and "visualization" in its place (see Coopmans et al. 2014: 3).

⁷² Coopmans and her co-authors offer this provocative image: "[c]omputer screens have pride of place in laboratories and scientific offices, where researchers' attentions are as likely—or more likely—to be focused on colorful digital images, simulations, software suites, databases, or lines of code as on unruly specimens or instruments. Biomedical imaging enrolls fMRI and PET scans alongside X-rays, which themselves are frequently digitally manipulated to produce new modes of vision... (Coopmans et al. 2014: 1).

“giving form to,” or the *in-formation* of the given. In short, data gains information that does not belong to it by right. He goes onto say that

data, reduced to their purest form of mathematical values, exist first and foremost as number, and, as number, data 's primary mode of existence is not a visual one...any visualization of data requires a contingent leap from the mode of the mathematical to the mode of the visual (Galloway 2012: 82).

It should be noted that I have serious misgivings about Galloway’s separation of raw, empirical data from information, mostly because it comes too close to endorsing the form and matter distinction that Gilbert Simondon calls “hylomorphism.” This is the tendency in Western thought to treat matter as inert and lifeless and only given form or organization from outside (see Simondon 2005 45-60).⁷³ Yet I don’t think this difficulty is insurmountable, mainly because Galloway’s general point is a good one: namely, that there is no *necessary* connection between a given material (data) and its potential for meaningful organization—in this case, *visual* organization.⁷⁴ This insight leads Galloway to his first thesis, which is that “*data have no necessary visual form*” (2012: 82). Or in other words, there is no visual form, or information, for a given data set. But even if this is the case, he observes that *networks*—which are what concern him—only have one visual form: nodes and edges.

⁷³ Essentially, Simondon argues that such a dualism ignores all of the intermediary phases the process of individuation. Matter is not inert, for Simondon; rather, it is “metastable,” or full of potential energy, and via a perturbation it can undergo a transformation that produces a more-or-less stable individual. But this individual is not determined ahead of time—as in hylomorphism—but emerges from a metastable field that does not prefigure it. In this way, form does not come from the outside but is an ongoing process. See Simondon, *L’individuation à la lumière des notions de forme et d’information*.

⁷⁴ In many ways, this formulation of data’s relation to information resembles Deleuze’s well-known Humean thesis, which is that “relations are external to their terms,” and is so crucial to the development of his transcendental empiricism in later works (Deleuze 1991: 99). For this latter development, see Jeffrey Bell, *Deleuze’s Hume: Philosophy, Culture, and the Scottish Enlightenment*.

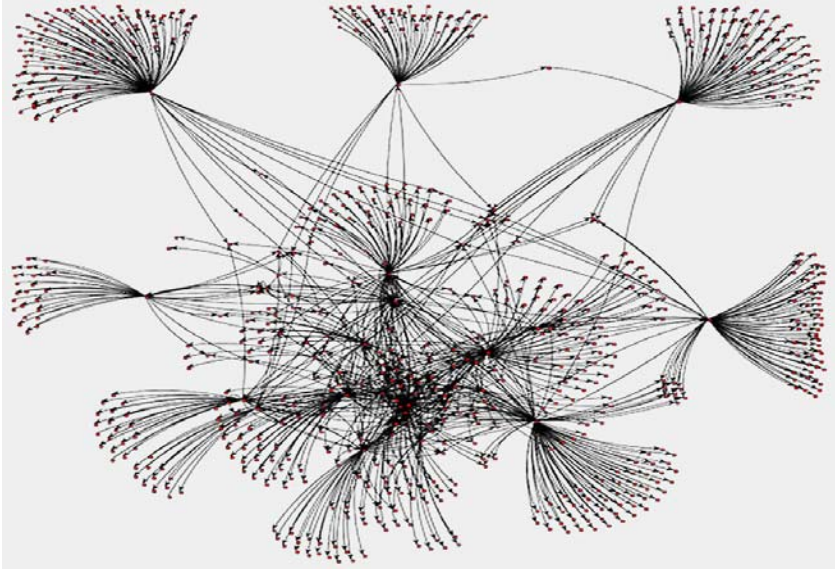

Figure 9: Twitter Network Visualization Social Graph, selected from a normal web search.

This leads Galloway to his second thesis: “*Only one visualization has been made of an information network*” (2012: 84). And as it turns out, it doesn’t matter if the visualization is of the Internet or of a human neural net, since “the hub-and-spoke cloud aesthetic predominates” (ibid.). In other words, “[t]he size of aesthetic space is one” (85). A “dialectical” (*sic.*) tension results between these two theses: there is no visual form and there is only one visual form. Or in other words: data is unrepresentable and yet it has only one representation. So what is it that prohibits other forms of visualization, other representations of data? Galloway’s central provocation is that it is the *control society* that mandates only one aesthetic form (see 91).

Crucially, Galloway demonstrates that a wider system of political and economic power ties data to information (which go onto explain below). In other words, control governs the logic of data representation in the age of cybernetic machines. My worry is that his description is still unsatisfactory, or at least in part, since it fails to capture the way in which data is joined to information in the control society. So for example, Galloway insists that it matters little whether

we're talking about the visualization of the Internet or a neural net, the aesthetic form is the same, and this is what indicates the rise of control: "one of the key consequences of a control society," he maintains, "is that *we have moved from a condition in which singular machines produce proliferations of images, into a condition in which multitudes of machines produce singular images* (2012: 91). The problem is that his description doesn't adequately capture how control societies govern the relation between data and visual form. Producing new ways to visualize networks doesn't resist the subtle workings of control (as his description implies), but only extends and intensifies its hold: new visualizations generate more variation, more options, more competition. We only have to recall that control does not work by "molding" as it did in disciplinary societies—"one size fits all"—but by "modulation," that is to say, subtle variations that play out indefinitely on "cybernetic machines" (see Deleuze 1995: 178-179). Thus, Galloway may even have it backwards: that is, we have moved into a condition in which one machine produces *proliferations of images*.

What Galloway forcefully demonstrates, however, is that representation is not irrelevant in the computer age: control now governs the subtle workings of visual representation. In other words, data is informed through control. The problem is that the logic of control is more subtle and flexible than Galloway's argument allows for. This is where I think STS research can be instructive. So for example, what interests Daston and Galison about scientific visualization in the twenty-first century is the *proliferation* of images and manipulations that are possible with digital tools. They cite the Visible Human Project as exemplary of how viewers can manipulate images by "using the navigational and image-modifying capability of the program" and "can produce in a moment an image that no one had ever seen..." (Daston and Galison 2007: 390). Where in previous eras there was an epistemic norm in place to guide object visualization (e.g., objectivity), now,

they argue, it is far less clear what that norm is. Flexibility and not rigidity seems to define what is valued in scientific visualization. While the “node” and “edge” aesthetic has a prominent place in the scientific, and especially the biological, visualization of complex systems and networks, it is not the only aesthetic available, even for network visualization. Surely molecular animation demonstrates this point vividly, since one of its main selling points is that it gives visual form to complex networks of molecular interaction with an added feature: movement over time.

What’s intriguing is that Daston and Galison conclude that the proliferation of visualization options— data can now have views that no one has ever seen before— means that representation no longer controls the visualization of scientific data. But with the help of Galloway and Deleuze, we now see that continuously varying the visual form that data takes does not spell the ruin of representation per se, but only indicates that the visual representation of data is governed by a new logic: the flexibility and competition of control. There is a presupposed norm, namely, market fundamentalism, which requires each image to vary from the previous one. Another way to put this would be to say that data visualization internalizes competition and champions it as the new “law” that needs expression. Competition is naturalized, transcending all other norms, and is expressed through generating (limitless) variation and difference that can compete in the market.

In the field of molecular animation this is evidenced in a couple ways. As noted previously, molecular animations are largely produced on proprietary software, such as Maya Autodesk and Maxon’s Cinema 4D; in addition, this sphere of visual science has deep ties to industry. These industrial ties are not simply the result of collaborations with the entertainment industry, however; rather, molecular animation has itself become a profitable sector of the “bioeconomy.” For instance, some of Digizyme’s (Gael McGill’s company) recent clients include Genetech, a biotechnology corporation that is a part of Roche; New England Biolabs, which does business in

protonomics, drug discovery, and DNA sequencing; the Ohmx Corporation, a clinical diagnostics company; and Bind Therapeutics, a nanomedicine platform company that develops programmable therapeutics.⁷⁵ Similarly, AXS Studio's (Jason Sharpe's company) clients include pharmaceutical companies such as Genzyme Canada, Amylin Pharmaceuticals, and Bayer Schering Pharma, as well as the eye health product company, Bausch + Lomb.⁷⁶ The take away here is that image production in this growing field, is increasingly guided by competitive markets. What remains unanswered, however, and will continue to remain unanswered due to yet insufficient research, is how and when, precisely, biological visualization became a profitable sector of the economy in its own right. While Daston and Galison allude to the fact that the "engineering ethos" played a large role in the new corporate climate in visual scientific culture in the 2000s (see Chapter 2 in this work), their analyses do not pretend to offer a thesis regarding the emergence of a visual bioeconomy.

Whatever the history of the "visual bioeconomy," it is widely understood that in order to effectively compete in this era of late (or even later) capitalism, requires new flexible modes of production: "modulations," instead of "molds," which are "like self-transmuting molding continually changing from one moment to the next" (Deleuze 1990: 179). Looking at the evolution of political economy in the West through the lens of cybernetics, Luciana Parisi and Tiziana Terranova show how the new modes of capitalist production, or "control," have even found a way to make "noise," "uncertainty," "death," and "resistance" productive in ways that thermodynamic capitalism couldn't have imagined—that is, entropic labor is no longer a threat (death) to the system but produces value (see Parisi and Terranova 2000). Thus, an inherent openness to change

⁷⁵ See their website for further details.

⁷⁶ See their website for further details.

and variation, where “nothing gets lost or wasted, [and] everything becomes useful” (200: 10), is what now drives capitalist accumulation.

And it is this drive for flexibility and variation, so that, in effect, nothing “gets wasted” and all can be made useful, that we can detect in the field of molecular animation today. What worries critics and proponents alike is that molecular animations draw from incredibly large data sets, and as such, a good deal of relevant data is left out of final renderings. Essentially, data is wasted. For example, in the timescales of cellular processes alone there are said to be 17 orders of magnitude, all of which would be impossible to render at once (see McGill 2008). And as anyone who has worked in bioinformatics knows, data is constantly updated, and at a rate that is impossible to manage scientifically, let alone render in a single image (see Fry 2007).

These challenges have been met with a series of innovations in the field of molecular animation. For instance, scientist and animator, Graham Johnson, recently developed software—plugins scripted using Maxon’s Cinema 4D program—capable of automating the image generation process. The idea is that the geometry and motion of cellular environments is continually updated from data mined from much larger and evolving data sets.⁷⁷ In this way, not only has static data been set in motion, but so has the process that generates that motion. In short, the animator is supplemented by a distributed-design system that subjects the masses of data to abstract calculations that give it a provisional form.

This closely parallels the work done in the field of information design by Suguru Ishizaki, among others, in which design becomes semi-automated: the human designer and computer must “improvise” in the form of a multi-agent system in order to produce temporary solutions to the

⁷⁷ See McGill, “Molecular Movies...Coming to a Lecture near You”; an interview with Gaël McGill and Graham Johnson by Protein Data Bank (PDB): http://www.rcsb.org/pdb/static.do?p=/education_discussion/animation/McGill-Johnson-QA.html; and Graham Johnson, *Automated Modeling and Visualization of the Cellular Mesoscale*.

ever shifting problem of visualization.⁷⁸ Similarly, computer animation promises to fit squarely within this field of semi-automated design, by generating molecular animations that can transform, shift, and rotate as needed. But individually, each animation will only ever have temporary value, since (a) there will always be a new animation of data that provides content that the others cannot, and (b) there is no final animation that could adequately *in-form* the masses of molecular data. The process goes on indefinitely.

In this perspective, the design of molecular worlds is open to constant change and variation. The semi-automated system is keenly “aware” of the need for perpetual updating, and indeed operates under this assumption. Through automated design, there is (ideally) no waste, or unused data, inasmuch as the system can find ways to incorporate it in a different iteration. Such improvisation ensures that a rendering is never final, but only a part of a much larger and evolving system that can include (or suffocate?) each possibility as it comes about. Combine this description of (or aspiration for) automated design in molecular animation with the technology’s deep ties to industry, then it’s easy to see how the field is exemplary of a neoliberalized technoscience. Through technical/design innovations, there is no data that cannot, in principle, be visually “informed” (to use Galloway’s description), and made to produce value. Nothing “gets wasted,” everything is productive.

This description also sharpens our understanding of how representation is still operative in molecular animation. Animations are increasingly valued insofar as they conform to competitive markets, and technologies that facilitate flexibility— e.g., innovations in semi-automated design— only help achieve this goal. In other words, competitive markets increasingly dictate how an image “informs” data; competitiveness, and not “accuracy” per se, is what makes an image a faithful

⁷⁸ See Suguru Ishizaki, *Improvisational Design: Continuous, Responsive Digital Communication*.

representation. In short, the image expresses the new law of Nature: market rationalism. Now, such a theory of representation is not, to be sure, based on a theory of visual mimesis or resemblance, which is why, I would imagine, Daston and Galison do not recognize it as representation. Moreover, such a theory of representation is based on a far more subtle and pervasive notion of recognition, where one thing is recognized in terms of another. One of my central provocations of this chapter is that representation is indeed operative in the field of molecular animation, but in terms of a more insidious, if difficult to theorize, form of representation that the neoliberalization of technoscience requires. To understand this form of representation, we return to Deleuze's earlier work.

Deleuze has written a great deal on the persistence of representation, and indeed on its inherent relation to the faculty of recognition, although perhaps most extensively in his 1968 work *Difference and Repetition*. Following Immanuel Kant in chapter three of this work, Deleuze argues that recognition is what allows each faculty to have an object to understand, judge, imagine, remember, and perceive; and as such, it is believed to "transcend" all other human faculties since it is operative in each of them. In short, recognition is what allows something to register as existing at all, and ultimately depends upon comparing new phenomena with that which is already known or experienced. So for example, I can imagine *this* only because I am able to *recognize* it in terms of this or that category of things, which is what is increasingly required of molecular animations—they are recognized as competitive or not.

Crucially, Deleuze critiques Kant's privilege of recognition because it presupposes representation, or what is "characterized by its inability to conceive of difference in itself" (Deleuze 1994: 138). The idea here is that representation cannot conceive of "difference itself"—the conceptualization of which is the holy grail, if you like, of Deleuze's project here and

elsewhere— precisely insofar as it subordinates difference to identity. And this function of representation is rooted in Plato: what is different is subordinate to the identity of an original, of which it is a mere copy (see Deleuze 1990).

But to understand why recognition presupposes representation, we first need a better sense of how the latter subordinates difference to identity. Deleuze’s most extensive discussion of representation in *Difference and Repetition* comes part way through his analysis of the “dogmatic image of thought” in Chapter Three. There, he argues that difference is subsumed under identity in four different ways: identity in the concept, opposition of predicates (via remembrance and imagination), analogy in judgment, and finally, resemblance in perception.⁷⁹ These are the different forms of identity, or representation, operative in each of the human faculties, and are undermined when we are forced to think difference in an “encounter” (Deleuze 1994: 139).⁸⁰ Without spelling out Deleuze’s theory of encounter just yet (see Chapter 3), suffice it to say that the deep hold representation has on human thought is overcome by “overturning Platonism,” which means undermining the primacy of the original over the copy, and affirm the simulacrum, which has no original.⁸¹

What’s essential is that Deleuze has shown us why recognition, which traverses each faculty, presupposes representation. Insofar as a faculty has an object at all, which is what recognition guarantees, then difference first needs to be subordinated to identity in one of four ways (analogy, opposition, resemblance, identity), which is what ensures the recognition of the

⁷⁹ Deleuze explains that “representation [is] defined by certain elements: identity with regard to the concept, opposition with regard to the determination of concepts, analogy with regard to judgment, and resemblance with regard to objects” (Deleuze 1994: 137).

⁸⁰ Deleuze writes: “Something forces us to think. This something is the object not of recognition but of a fundamental encounter” (1994: 139).

⁸¹ This is a crude summary of what is involved in overturning Platonism for Deleuze. Please see Deleuze’s *The Logic of Sense*, as well as Dan W. Smith’s article, “The Concept of the Simulacrum: Deleuze and the Overturning of Platonism.”

object (“ah yes, I recognize that”). In short, to recognize anything, even if it is a purely imagined, future scenario, requires identitarian, as opposed to differential thinking.

The significance of Deleuze’s insights on representation cannot be overstated. What they make apparent is how representation has not been overcome with digital imaging in science, but it has merely assumed a new form. Animate images do not fabricate or build a world that is not already rooted in the one we currently inhabit. Increasingly, they must be recognized *as* competitive—and competition very much characterizes the world we currently inhabit—in order to be valued. This is not to say that visual resemblance, or mimesis, have no role to play in the construction of animate molecular worlds—they clearly do. It’s to say that we live in a technoscientific world in which the line between the laws of the market and the “laws of the natural world” have become blurred, if not indistinguishable. And molecular animations are recognized in terms of that indistinguishable world to be valued.

What should be clear by now is that computer animation’s increase in scientific value corresponds to the rate of its subsumption under a logic that resembles what Deleuze calls “control.” In fact, what is valued now in molecular animation comes startlingly close to what Deleuze sketches at the end of *Foucault* and *Cinema 2*: in short, the new generation of animations promise to generate images that are indeed capable of being the “object of a perpetual reorganization, in which a new image can arise from any point whatever of the preceding image” (*Cinema 2*), and therefore give visual form to the fact that life’s code is made of “a finite number of components [that] yields a practically unlimited diversity of combinations” (*Foucault*).

What worried Deleuze is that the cybernetic shift in biology and moving-image technology is an expression of a much wider post-disciplinary logic that, as Foucault puts it, subsumes “all aspects of the social body and including the whole of the social system” (Foucault 2008: 243). The

cybernetization of the moving image and biology is an expression of a market rationalism that has become generalized. There is a shift in power dynamics such that there is no longer an outside to the production of (neoliberal) value through cybernetic machines. And when moving images and biological systems converge in third-generation machines, as Deleuze anticipated, and is achieved in biology labs/studios today, the very clear implication (according to Deleuze) is that our ability to think cinematic time and biological life is under siege. This isn't to say of course that biologists aren't scrambling to piece together an understanding of both time and life when they animate their data—it is precisely their conjunction in molecular animation that makes the practice so appealing. Rather, it is to say that our ability to think time and life is in the grips of an economic calculus with no clear outside.

Before I conclude, it's important to note the way in which labor, and specifically *scientific labor*, transforms in this era of digital science as well. The digitization and automation of scientific work in molecular animation can also be understood as an expression of the general transformation in value production in post-Fordist economies that has been theorized by neo-Marxists from the Italian Autonomist and post-Autonomist traditions.⁸² Labor is now distributed across cybernetic machines, and embraces both the “cognitive” and “affective” dimensions of life in the production of neoliberal value.⁸³ This transformation—which may be broadly understood as transition from the “formal subsumption” of labor to the “real subsumption” of labor, in which aspects of social life are forms of production⁸⁴—also concerns Deleuze in *Foucault*: “[d]ispersed work,” he writes, “had to regroup in third generation machines,

⁸² See especially Negri, *Marx Beyond Marx: Lessons on the Grundrisse*; Paolo Virno, *A Grammar of the Multitude: For an Analysis of Contemporary Forms of Life*; Maurizio Lazzarato, “Immaterial Labor” and *The Making of the Indebted Man*; Franco “Bifo” Berardi, *The Uprising: On Poetry and Finance* and *The Soul at Work: From Alienation to Autonomy*; and Hardt and Negri, *Empire and Multitude*.

⁸³ See Lazzarato, “Immaterial Labor,” and Hardt and Negri, *Empire*.

⁸⁴ See Hardt and Negri, *Empire*, 25.

cybernetics and information technology” (Deleuze 1988: 131). And it is precisely this notion of “dispersed work” that is articulated with precision as “immaterial labor” by Maurizio Lazzarato, Michael Hardt, Antonio Negri, and others. It seems to me, then, that scientific labor—which is in no way insulated from the “immaterialization of labor”—needs to be investigated in neo-Marxist terms. Such a discussion would bear directly on Daston and Galison’s treatment of the production of “scientific subjectivities,” which have yet to be fleshed out in the context of the twenty-first century scientist.⁸⁵

1.5 Where Does This Leave Us?

This discussion leads me back to my original question, which is: Do Deleuze’s late reflections on control societies still have critical purchase today? That Deleuze’s notion of “control” is not championed as a forerunner to the wrath of twenty-first century neoliberalism in the way that Foucault’s, Jameson’s, and now Hardt and Negri’s theories of late capitalism are, should not come as a complete surprise. Deleuze’s work on the control society in the “Postscript” is meager at best. Thus, to assess whether control still has any critical purchase requires placing his brief reflections from 1990 in the context of his ruminations on cybernetic machines and political and economic power scattered throughout other texts, such as *Foucault*, *Cinema 2*, *Francis Bacon*, *Difference and Repetition*, *Anti-Oedipus*, and others.

As this chapter has tried to demonstrate, it is by piecing this work together that we can begin talk with specificity about the emergence of a new epistemic regime in the sciences. In fact, my central provocation all along has been that Deleuze’s work anticipates not only the technical

⁸⁵ Daston and Galison’s treatment of the subjectivity of the twenty-first century technoscientist (or entrepreneur-scientist) is incredibly thin when compared to their analyses of early forms of scientific subjectivity. A more detailed consideration of newly emerging technoscientific subjectivities is required.

convergence of the cinema and biology (of course it is striking how his informatic descriptions of the cinema and biology set the stage for what's taking place in molecular animation), but also why, precisely, this convergence would be valued. Thus, reviving control societies is important not simply to preserve Deleuze's legacy, to point out, for example, that his political-economic insights are not limited to 1968 capitalism—a world that we no longer inhabit. Additionally, revisiting control doesn't imply that Deleuze's vision trumps descriptions of “neoliberal governmentality,” “postmodern capital,” or even “Empire.” Rather, my argument is that control gives us the technical and social coordinates for explaining why the cybernetization of *life* and *time* is worrisome, and moreover, why this is meaningful to scientists.

In doing so, Deleuze's reflections on control also make key interventions into both STS and media-studies research today. On the one hand, control extends foundational work in the history of scientific epistemology by locating the production of value in scientific visualization outside of the sphere of scientific practice (that is, away from more “internalist” histories of science), and resituates it in a wider political and economic field. In this way, “control” has deep resonances with work on the co-production of scientific and economic value explored by Rajan (2006), Cooper (2008), Catherine Waldby and Robert Mitchell (2006), Eugene Thacker (2006), and others. And on the other hand, Deleuze's work intervenes in assumptions about the relation between data and visual information in media-studies discourses today by stressing how, precisely, control accounts for their relation in terms of flexibility and not rigidity. This extends important work on information technologies and neoliberalism by media scholars such as Galloway (2004, 2012), Tiziana Terranova (2004), Jonathan Beller (2006), Raiford Guins (2009), and many others.

In making these interventions, however, I have also emphasized that STS and media-studies research intersect each other in crucial ways, and even require each other to sort out

interpretive difficulties over the persistence of representation in digital science. Thus, if Deleuze's reflections on control societies still resonate with us today, it is because they catalyze these intersections. Indeed, one of the crucial upshots of bringing control to bear on these cross-disciplinary discussions is that it sharpens our ability to see how molecular animation does not disrupt the strong hold that representation has had on scientific epistemology for centuries. Rather, it only signals its new contours (I discuss the contours of representation in more detail in Chapters 2 and 3). What Daston and Galison fail to appreciate, then, is how true their thesis about representation truly is: it persists even when novelty and flexibility characterize the norm of scientific visual culture.

And, yet, I want to suggest that our understanding of molecular animation is far from complete. Indeed, up until this point the technology has been circumscribed by Deleuze's view of neoliberal control. But this only tells a very particular story about the technology, one that would believe that machines explain everything, or in any case, one that insists upon the fact that "machines determine different kinds of society" (Deleuze 1995: 180). This would be an incredibly narrow reading of Deleuze's (and Guattari's) work, and digital technology more generally, and it is one that I do not share with thinkers like Galloway. I firmly believe Deleuze when he says that "machines don't explain anything" (ibid.), and that their explanation resides in the "collective assemblage" to which they belong. And that collective assemblage, as we have seen, indexes the deeper "mutation in capitalism" known as neoliberalism, or market fundamentalism. Thus, when Deleuze calls upon us in *Cinema 2* to find "another will to art" that may discover "as yet unknown aspects of the time-image" in a post-digital world (Deleuze 1989: 266), he is not advocating that we abandon digital

technology. Rather, he is insisting that we abandon the “image of thought” or “collective assemblage” that determines how we use the technology.

As this chapter has shown, the collective assemblage that gives meaning to computer animation within molecular and cellular biology is one that requires it to represent the laws of flexibility and competition, or in other words, those laws of the market that have been “naturalized.” How, then, do we intervene in the use of this technology for science? Very clearly, this entails discovering or inventing a new collective assemblage qua scientific culture for molecular animation. But what, precisely, does this mean? Does it mean forging one that promotes representing a form of Nature that is irreducible to the laws of the market, or any other political and economic circuits of power? In other words, is there a scientific culture in which Nature is released from regimes of political power and worthy of representation?

As will become clearer in the chapters that follow, this dissertation will insist upon the fact that Nature is never separate from the political and economic circuits that deem something natural. This is a point that Foucault never tires of stressing, and he articulates with great precision in *The Order of Things*. There, he famously argues that Life did not even exist until the nineteenth century (see Foucault 1994: 127), and it is the biopolitical circuits of power, he contends elsewhere, that continue to reproduce what we have come to think of as the “life of the species,” for example (see Foucault 2003). Deleuze sides with Foucault’s critique of Nature, though his methods and conceptual apparatuses are often less legible. For Deleuze, the deployment of Nature, or at least as it is done so in the history of Western thought, isolates a set of entities and/or beliefs—whatever those they may be—and allies them with what is “essential,” “primary” “real,” “actual,” and (very often) “scientific,” and simultaneously opposes them to what is deemed “inessential,” “secondary,” “artificial,” “imaginary,” or merely “virtual.” Nature thus imparts a transcendent

position from which to judge all entities and beliefs. What Deleuze and Deleuze and Guattari take pains to do in much of their work is to identify how this division, or bifurcation (to use Whitehead's term), has manifested itself in the history of Western thought by means of different collective assemblages—disciplinary, biopolitical, neoliberal, etc. In this way, Deleuze's plea for "immanence" is not, I would insist, a new "Naturalism" (as some critics have argued⁸⁶), but it is the consequence of a conceptual pragmatics that aims to overcome the allure of Nature as such.⁸⁷

The take away point here is that the "accuracy" of our conception of Nature is not the problem. Rather, the problem is that there is a conception of Nature all, which generates the illusion that there is something autonomous to be represented. As I argue in the following chapters, the representation of Nature always falls into the trap of referring to what has been constructed *as* natural by particular circuits of power. Thus, molecular animation is not exceptional for its determination by political and economic forces; quite the contrary is true: visual representation in science has never been "neutral," which is to say, separate from wider systems of power. As we will see in Chapter 2, cultural theorists such as Lisa Cartwright have done important work to dispel the myth of visual neutrality in the sciences. The "will to representation" thus only strengthens the belief in the autonomous existence of Nature. If we are going to find another "another will to art," or for our purposes, another "will to science," for molecular animation, then it will have to resist the lures of representation.

This is much easier said than done. So for instance, we have already noted how deeply ingrained the norm of representation is within scientific visual culture, and scientific epistemology

⁸⁶ Deleuze scholars have debated for many years now whether Deleuze is a "naturalist." Levi Bryant, for his part, is an ardent defender of Deleuze's naturalism in the *Democracy of Objects*. For a more subtle account of Deleuze's thought, see Gregory Flaxman's, *Gilles Deleuze and the Fabulation of Philosophy*. There, Flaxman argues for a notion of creative philosophy that would render the kind of naturalism that Bryant and others insist upon impossible.

⁸⁷ See my article, "Imaginative Chemistry," in *The Lure of Whitehead*, for a full discussion of life in Deleuze and Guattari.

more generally. This is so much the case that even when many think it is undermined, it is actually reinstated in a different guise. As I argue in Chapter 2, this is more true than many scientists and scholars may be willing to admit. In any case, the real question is: Can there be non-representational scientific visuality?

What's promising is that there may already be hints of this kind of thinking in field of molecular animation itself. For example, in her article, "Animating the Model Figure," Janet Iwasa at Harvard University Medical School, suggests that the primary virtue of molecular animation is not its capacity for representation (*pace* Sharpe and his colleagues), but its ability to propose new relationships among data sets that may or may not be verifiable. In other words, animation has a deeply "hypothetical" quality to it, which she calls upon us to embrace (see Iwasa 2010: 702). This kind of technology, she insists, can lure us into new ways of scientific thinking. For instance, it can propose new ways to fold in the spatial and temporal dimensions of motor proteins such as dynein, which still baffles scientists (*ibid.*).

The difficult question here is whether this potential, which I return to in the Conclusion, has not always already been co-opted by neoliberal circuits of power. In other words, is it really possible for this kind of claim to sit comfortably within a scientific culture that is so beholden to the political economies of representation? This prompts us to ask a series of questions that will guide our investigation: Are there are instances in the history of scientific imaging that have overcome the lure of representing Nature and which could serve as a model for molecular animation? And if there are, wouldn't they also function as forms of political resistance? But then wouldn't such a visual culture have to exist on the fringes of the dominant scientific culture of representation? Maybe this is what Deleuze and Guattari meant by "minor science" (Deleuze and

Guattari 1987). Whatever the case, these are the questions that I will pursue in order to discover what I'd like to call another "will to science" in a post-digital world.

Chapter 2: The Micro and the Nano: New Scales of Representation

2.1. Minor Histories

At the close of the previous chapter I asked whether it is possible to discover nonrepresentational values within scientific visual culture. I also asked whether such a visual culture, if it should indeed exist, could sit comfortably within scientific culture more generally, given that the latter is so steeped in representational values. As I argue in this chapter, it's tempting to see a plethora of nonrepresentational visualizations in the history of scientific visualization. There seem to be countless instances, for example, of scientific images (in photography, microcinematography, etc.) that fail to adhere to the norm of representation. Of course, these images may not have been generally accepted as valuable instances of scientific imaging—inasmuch as they have been accused of generating “biological fantasy worlds”—but surely a nonrepresentational visual culture exists within the archives of scientific visibility. And more recently, aren't there clear instances of scientific imaging that reject the inherited assumption that they are supposed index a pre-given material world, instead of helping to construct a new one? Surely this qualifies as a form of nonrepresentational scientific visibility, and indeed one that is increasingly accepted as scientifically valuable.⁸⁸

This, in any case, would appear to leave the path to nonrepresentational values within scientific imaging rather wide open—images that do not uphold the values of representation might very well abound. Indeed, the possibility of finding new models for molecular animation would be very much within reach. But as I go onto argue in this chapter, a number of the so-called “failed” scientific images are in fact representationally successful. And then even visualizations that seem

⁸⁸ See Daston and Galison, *Objectivity*, Chapter 7.

to challenge representation, and indeed appear to do so rather explicitly, are very rarely successful at doing so. In fact, carving out a space for *nonrepresentational* values within scientific visual culture will prove to be far more difficult than initially thought: oftentimes, images that seem to bear all the signs of nonrepresentation secretly desire it.

Once again, I am deeply indebted to Deleuze and Guattari on the differences between “royal” and “minor” sciences for my understanding of representational and nonrepresentational science (see Deleuze and Guattari 1987: 372; 411). For them, royal or state science is characterized by “reproduction, iteration and reiteration” so that “differences of time and place [are] so many variables, the constant from which is extracted precisely by the law” (Deleuze and Guattari 1987: 372). As will become clear, the scientific visual culture that predominates, and I describe in what follows, displays a commitment to representation, in its numerous manifestations, to ensure that a presupposed value or “constant” (whatever that may be) is visually reproduced in some form. In this way, the visual culture very much manifests the characteristics of state science. Minor science, by contrast, is characterized by “following,” not in order to “reproduce,” but in order to “search for the singularities of a matter, or rather of a material, and not out to discover a form” (372). The latter is an ambulant procedure for setting variables in “continuous variation” instead of the royal procedure of extracting constants from them in order to reproduce them. Crucially, the opposition between the two procedures is far from absolute: “more virtual or ideal than real is the opposition between the two kinds of science,” insists Eric Alliez (Alliez 2004: 48). Deleuze and Guattari explain that ambulant processes are inseparable from their formalization by royal science. For example, primitive metallurgy, which characterizes “minor science in person” (1987: 411), is never divorced from its royal formalization since it is just as easily conceived as a “question of

going from one point to another (even if they are singular points) through the intermediary of channels” (372).

What’s important for us is that Deleuze and Guattari help clarify why minor science cannot exist as a practice wholly separate from “royal formalization.” They explain that, “ambulant procedures and processes are necessarily tied to striated space—always formalized by royal science—which deprives them of their model...” (1987: 372-373). Thus, nomad science never exists in a autonomous state, independent of royal procedures that seek to cover over ambulant ones.

Deleuze and Guattari offer us a conceptual framework for understanding why nonrepresentational imaging does not—and perhaps even cannot—exist as a scientific practice in its own right. As they insist, minor or nomad science is found on the fringes of major or royal ones. In fact, it most likely won’t even be recognized as “scientific” by its royal counterparts; it’ll be lurking in the latter’s shadows, since its very existence would upset the “image of thought” that binds scientific practice to representation.⁸⁹ This is why nomad practices must insist, virtually, rather than have an autonomous existence. And according to Deleuze and Guattari, nomad science deserves nothing more and nothing less:

It is not that the ambulant sciences are more saturated with irrational procedures, with mystery and magic... And the royal sciences, for their part, also surround themselves with much priestliness and magic. Rather, what becomes apparent in the rivalry between the two models is that the ambulant or nomad science do not destine science to take on an autonomous power, or even to have an autonomous development. They do not have the means for that because they subordinate all their operations to the sensible conditions of intuition and construction... (1987: 373).

⁸⁹ “Shadowy” figures abound in Deleuze and Guattari’s characterization of nomadism. For example, the metallurgist is characterized as a “cosmic artisan,” whose practice designates “minor science in person, ‘vague science,’ or phenomenology of matter” (Deleuze and Guattari 1987: 411). Deleuze and Guattari also describe those figures on the borders, or on the fringes of a group, as “sorcerers”: they have always held the anomalous position, at the edge of the fields or woods. They haunt the fringes. They are at the borderline of the village, or *between* villages” (246).

Nomadic science is incapable of becoming a practice that could be distinguished from other practices, and hence have an “autonomous development.” It does not have a distinct identity, which is to say, a set of characteristics or qualities that would differentiate it from other practices. And to be “identifiable,” as we saw in Chapter 1, is to subordinate “pure difference” to “identity” through representation. As such, nomadic science is a nonrepresentational science that is more like a specter that “haunts” state science; it is a kind of “para-science” that could never be separated out from, but always occurs along side of (virtually), actual scientific practice (even making it possible).

Thus, finding nonrepresentational, and hence nomadic, values within scientific visualization has deep affinities with current media archeological practices. As already outlined in the Introduction, if there is a defining characteristic of “media archeology,” now in its diverse and often conflicting forms, then it is its deep commitment to exposing how our received histories of media are but one among many possibilities that could have emerged but didn’t. Sharing much with Foucault’s genealogical method, the media archeology I follow here (see Introduction) protects history’s heterogeneity by

identify[ing] the accidents, the minute deviations—or conversely, the complete reversals—the errors, the false appraisals, and the faulty calculations that give birth to those things which continue to exist or have value for us; it is to discover that truth or being lies not at the root of what we know and what we are but the exteriority of accidents (Foucault 1977: 146).

Thus media archeology by and large aims to expose the moments that challenge simple origins and express the fact that “it could have been otherwise.” It is in keeping with this spirit that I aim to resurrect nonrepresentational values within scientific visualization in order that molecular animation is able to secure a new foothold within a history of scientific imaging.

To begin this task, I bring together two moments from the archives of scientific visualization that vividly demonstrate just how difficult discovering this “minor” history truly is. The first incident comes from early twentieth-century microcinematography, and the second comes from twenty-first century nanomanipulation technologies. The reason for bringing these highly diverse, and otherwise incongruous, practices together is that they have each been accused of, and sometimes championed for, being nonrepresentational (see Medawar 1986; Daston and Galison 2007). But upon much more careful scrutiny, I argue that each of these practices actually do champion representation, and are thus perfectly compatible with the norms upheld by the dominant history of scientific epistemology. Moreover, I contend that each instance expresses a confrontation between representation and aesthetics, but one that is resolved, in each case, in a more evolved sense of representation. (There is a strangely Hegelian spirit to scientific epistemology.) The upshot of this study is that we also gain a path forward, albeit via negativa: that is, we will clarify, with much more precision, how it is that what counts as representation evolves in scientific epistemology (we already touched on this in Chapter 1); this means that representation is not one thing, but a deeply rooted model for knowledge production in science that transforms according to various circuits of power. We will also gain a much clearer picture of how it is that scientific imaging would be able to overcome the firm grip of representation: through aesthetics. In our study of these two visual practices, the aesthetic will emerge as the biggest threat to scientific representation. This will therefore require us in Chapters 3 and 4 to sharpen our understanding of the relation between aesthetics and representation.

2.2 The Micro

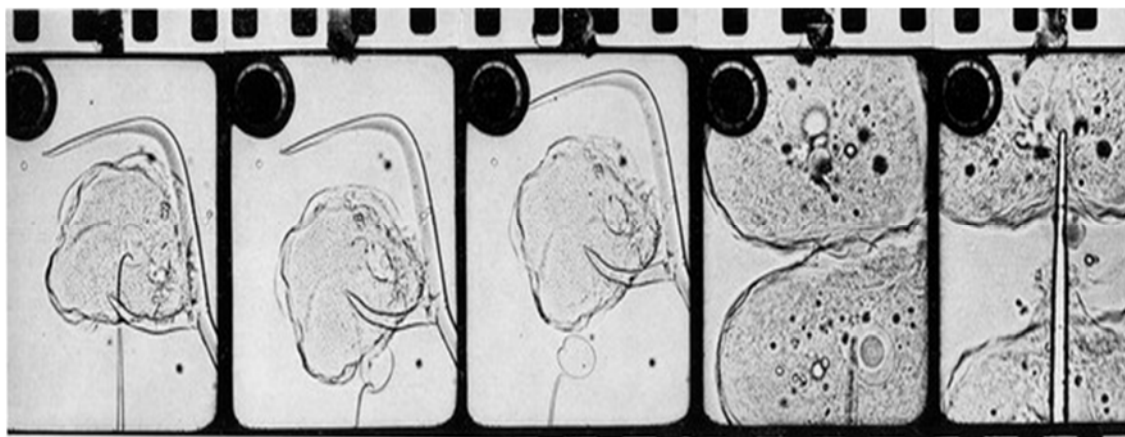
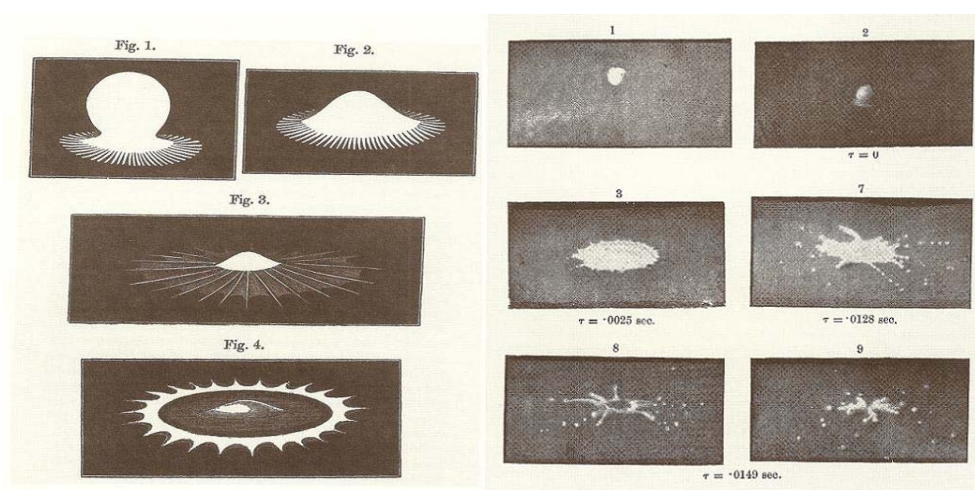

Figure 10. From “Substitution du noyau chez une amibe: *Amoeba Sphaeronucleus*,” Jean Comandon and Pierre de Fonbrune, c. 1938.

To understand the significance of microcinematography for scientific epistemology, we must first situate it in the context of earlier imaging practices, particularly photography. One of the important services that Daston and Galison provide in their work, *Objectivity*, is to highlight the absolutely central role that photography played in the formation nineteenth-century scientific epistemology. To set the stage for photography’s grand entrance into science, however, they tell the a story of the nineteenth century British physicist, Arthur Worthington, whose hand drawings of key moments of the impact of liquid drops—a “few thousandth of a second apart”—were instrumental in founding a branch of fluid dynamics. For Worthington, the perfect symmetry of the water droplet was what he aimed to represent in his drawings— not the “helter-skelter assembly of peculiarities,” but the world in its “types and regularities” (Daston and Galison 2007: 11).

And then, in 1894, everything changed. Using the photographic apparatus, Worthington was finally able stop the droplet’s splash. He captured the droplet as it “really is,” rather than according to the hand-drawn interpretation of the image left on his retina. And what he saw, to his dismay, was that the droplet was *not symmetrical*. Instead of the idealized, perfected form of the

droplet that he had been accustomed to drawing, what he saw were irregularities. Worthington notes that, “The first comment that anyone would make is that the photographs, while they bear out the drawings in many details, show greater irregularity than the drawings would have led one to suspect” (in 2007: 13). Later, Worthington confesses that after looking over his original drawings, he discovers many asymmetrical forms, but since such irregularities don’t repeat, the images were discarded, never published. He writes that, “the mind of the observer is filled with an ideal splash—an Auto-Splash—whose perfection may never be actually realized” (ibid.).



Figures 11&12: Worthington’s symmetrical (figure 11) and asymmetrical (figure 12) splash images taken from Daston and Galison’s *Objectivity*.

What Worthington realizes is that there is a deep human desire in the sciences to look past asymmetries and irregularities in order to capture nature’s idealized forms, the forms underlying all of the accidents. This tendency to choose the “perfect” over the “imperfect” was not unique to Worthington, or even to his branch of physics, but was a well-worn habit of scientific and philosophic thought that was centuries old.

To see nature in its ideal form—from the Vitruvian Man to the liquid droplet— was no longer an epistemic virtue according Worthington. On the contrary, it was a human oversight that

betrayed an unwillingness to see nature as it *really is*, in all of its imperfections. It was an idealization of nature that needed to be guarded against. Thus, in 1895 Worthington told an audience to discard the older images of symmetry. And in its place, he called for an “objective view” of nature, that is to say, images that capture “the physical world in its full-blown complexity, its asymmetrical individuality” (in Daston and Galison 2007: 16).

This instance, and countless others like it, exemplify how an epistemic mutation was underway in the nineteenth-century sciences, and in particular how photography was instrumental in bringing it about. For Worthington, photography exposed not only nature as it is “in itself” (at least “ideally”) but also, and crucially, how previous epochs idealized nature, obscuring what was really there in favor of “all-too-human” understandings of it. In this way, the culture of mechanical objectivity that began to flourish in the nineteenth-century sciences also, and simultaneously, disciplined the subject. “First and foremost, objectivity,” write Daston and Galison,

is the suppression of some aspect of the self, the countering of subjectivity. Objectivity and subjectivity define each other, like left and right or up and down...If objectivity was summoned into existence to negate subjectivity, then the emergence of objectivity must tally with the emergence of a certain kind of willful self, one perceived as endangering scientific knowledge (2007: 36-37).

The self that threatened scientific epistemology was the self cultivated and celebrated in “artistic” domains. Where previous eras, the Renaissance and Enlightenment, for example, made no firm distinction between artistic and scientific practices, beginning in the nineteenth century their respective domains bifurcated. During this period, art needed to express, even parade its subjectivity in order to be worthy of the name. Whether depicted in paint on canvas or words on a

page, the world expressed needed to bear the signs of emotion, memory, and desire—in short, express a world that was deeply personal.⁹⁰

The sciences, by contrast, did everything they could to safeguard against the intrusion of subjectivity. And this is precisely what worried Worthington: he saw idealizations in his own work, and demanded that subjectivity be reigned in, disciplined. Nature would no longer be obscured by idealizations of it. The photographic apparatus thus played an integral role in ensuring that the subject's desires were restrained. Photography promised to *mechanically* reproduce nature without the intervention of human judgment.⁹¹ In short, the automation of image production in the sciences ensured that the self that flourished in the arts could no longer interfere with the reproduction of the physical world. To reproduce an object without a subject— or in any case, a subject who is self-restrained observer who modeled himself on the machine— was the ideal of nineteenth century imagists. Mechanical objectivity was the highest virtue of scientific epistemology.

In fact, scientists held to the ideal of objectivity to such an extent that scientific photography was lauded in many instances for its imperfections, as a means of parading its commitment to non-interventionism, to judgment-free representation. One of the most striking examples comes from the German physician, Erwin Christeller, who in the 1920s so strongly advocated the purely mechanical reproduction of scientific objects that he insisted on leaving imperfections in the photograph. Daston and Galison quote Christeller:

With the exception of the elimination of any foreign bodies [such as] dust

⁹⁰ Fredric Jameson says something similar claim about modernist art in *Postmodernism or, The Cultural Logic of Late Capitalism*.

⁹¹ There is an interesting parallel between the ways in which the mechanical objectivists in science and the Surrealists, especially Dali and Brunel, valued the automatic recording of objective reality in photography and the cinema. Indeed, for many Surrealists, flawed and imperfect representations were part and parcel of an “objective view” of nature. I look at the Surrealists more carefully in Chapter 3. This deep, if unnoticed, connection between science and art complicates Daston and Galison's characterization of the separation of two. Although it should be noted that many of Surrealists were adamant that they were not producing “art”—it was anti-art. See Malcolm Turvey's excellent discussion of Surrealist cinema in *The Filming of Modern Life: European Avant-Garde Film in the 1920s*.

particles or crack lines, no corrections to the reproductions have been undertaken, so that the technically unavoidable errors are visible in some places. For example, there are small intrusions [*Überschlagstellen*] of the fibrous tissue fringes on the edge of the sections; [there is also an] absence of soft tissue components... I displayed these imperfections because I believed it my obligation also, at the same time, to display with great objectivity the limits of the technique (Daston and Galison 2007: 172).

Thus, for Christeller, like so many others, imperfections testified to the scientist's commitment to objectivity, and ultimately, to the kind of "self-surveillance" (*sic.*) that was demanded and extolled by objectivists. In short, only when the self was restrained could nature have the chance to appear as it really is.⁹²

And, yet, praise for mechanical objectivity was by no means universal by the first decades of the twentieth century. First slowly, then faster, scientists began to recognize the limitations of the automation: for example, when it came to the "very small," mechanical reproduction was incredibly limited. For certain biological cultures, drawings were far more revealing: while the photograph could depict individual entities in astonishing detail, drawings were superior at revealing whole cultures and relationships of depth. Thus, many scientists found that despite the appeal of automation, drawings were often pedagogically and diagnostically superior (see 2007: 179). Additionally, most scientific imagists recognized that objectivity was more of a "regulative idea," in the Kantian sense, than something achievable in reality. While this fact did not discourage many scientists in their everyday practice, it was much more of an article of faith than something that could actually be brought into being.

Although Daston and Galison do not take their analysis in this direction, I would argue that cell biologists were among those who were acutely aware of photography's— and even objectivity's—shortcomings due to the complexity of their subject matter: life itself. It is because

⁹² Although I do not have the space for to get into this in more detail here, Daston and Galison argue how the story about objectivity is also a story about the cultivation of a scientific self. The two go hand in hand. See Daston and Galison, *Objectivity*, Chapter 4.

of this, that they devised new technical means for visualizing it. As cell biologists in the late nineteenth and early twentieth centuries knew all too well, living cells are not static structures, but dynamic systems that change over time. But how could one actually visualize this? How could scientists represent tiny specimens', such as bacteria, development over time? Biologists were well aware that photography was a tremendous advancement over earlier methods of drawing. Hannah Landecker has done exceptional work in this field, and quotes the Swiss biologist, Julius Ries, who writes in 1909 that,

[o]n the one hand, a good many things in a living object happen too quickly, whereas on the other hand the advancing segmentation demands hours of the observer's attention. In this way, impressions become blurred and one gets tired. But if one attempts to capture individual pictures through sketching, one gets at the end only a composition of memory-images. The segmentation happens so fast that even the fastest sketch-artist cannot keep up with it (Translation in Landecker and Kelty 2004, Ries 1909: 1).

With photography, scientists could capture development—at least ideally—at each stage. Using classical histological methods of fixing and photographing specimens at different stages of their development,⁹³ Ries would then cut and paste photographs together sequentially so that he could observe the organism's change over time. Despite the tremendous advancement over drawing, photography still failed to capture change. “There is still an enormous difference,” Ries laments, “between the best fixed preparation and the living one. Aside from the many artifacts that are stuck to the dead fixed preparation, it also differs from the living in its motionlessness” (ibid).

As a consequence, Ries began searching for other visual technologies that would better capture the living, which is to say, *changing* organism. In pursuit of this, he is one of the first biologists to use cinematography in the laboratory.⁹⁴ Working with a vertical standing microscope

⁹³ See R.L. Holmes, *Living Tissues: An Introduction to Functional Histology*.

⁹⁴ For a more thorough account of this event, please see Landecker and Kelty, “A Theory of Animation: Cells, L-Systems, and Film.”

and a Lumière cinematograph, Ries condensed fourteen hours of sea urchin development into two minutes, projected at sixteen frames per second.

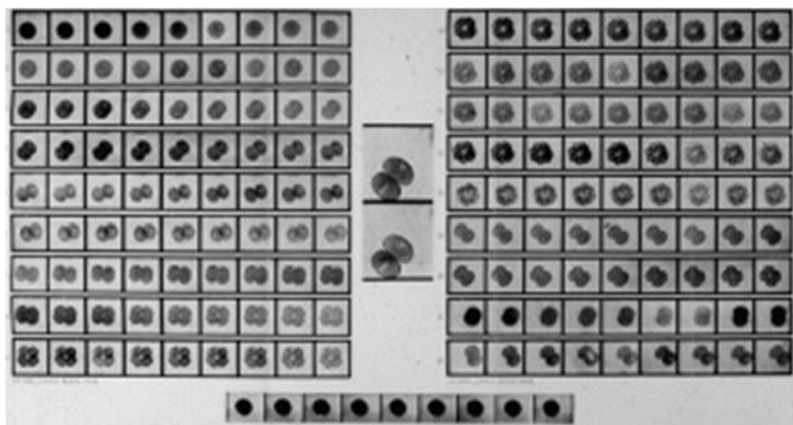

Figure 13: Fertilization and development of the sea urchin embryo by Julius Ries (1907).

What was striking about the film is that it allowed Ries to finally see the same organism change over time. Before, there were different organisms fixed and photographed, and it was up to the scientist's imagination to stitch segments together into a continuous whole. Now, there was a temporal continuity to development, and it was unfolding before the scientist's eyes. In other words, where photography provided the spatial coordinates for development—indeed the countless spatial segments—the cinema provided its temporal coordinates. It was as if life itself was unfolding in the image. Ries continues:

Even in the demonstration of my only twenty-meter-long film, which took at most two minutes to unfold, the effect was surprising; visible in the same egg is the formation of the fertilization membrane and the advancing segmentation up to the morula. One really believes one has a living, developing egg before one (translation in Landecker and Kelty 2004, Ries 1909: 6).

In short, movement over time was no longer an imagined characteristic of life, something that the scientist had to mentally insert between each static image, but a phenomena that could be seen for

itself. My interest “is not concentrated solely on separated images,” Reis insists, “but on the possibility of reconstructing the complete phenomenon of fertilization through projection”(translation in Landecker and Kelty 2004, Ries 2010: 225).

Ries was not the only biologist to experiment with time-lapse micro-cinematography in the early twentieth century. Hannah Landecker and Christopher Kelty note that at exactly the same time that Reis made his film, Louise Chevreton and Frederic Vlès, who were also in Paris, made a nineteen-minute film of sea-urchin development (see Landecker and Kelty 2004); although they were each completely unaware of the other’s experiments. These overlapping incidents, Landecker and Kelty conclude, speak to a deeper desire among scientists to capture the illusive fact that life changes over time. With microcinematography, it finally seemed possible for the “thing itself,” the movement of life, to appear in the image.⁹⁵

The realization that there might be a deep, perhaps even metaphysical, connection between life and the cinematic image was not restricted to scientific circles in Paris, however. Early film theorists made similar suggestions, albeit with a different emphasis. Perhaps most famously, Sergei Eisenstein argues in “The Cinematic Principle of the Ideogram,” that the shot is a montage *cell*, and its combination with other cells, much as it is with a living organism, “form[s] a phenomenon of another order, the organism or embryo” (Eisenstein 1977: 37). Organic and inorganic cells merge for Eisenstein. Likewise, Siegfried Kracauer notes that the cinema gives us privileged access to “the concept of life as such” (Kracauer 1997: 169), and he pays special attention to film’s origins in scientific research (1997: 50), a connection that Lisa Cartwright has more recently devoted considerable attention to (see Cartwright 1995).

⁹⁵ This story is in many ways complicated by the fact that the “source” of life was still not seen. In other words, while cinematography was able to depict the movement of life, the molecular world was still invisible. See Evelyn Fox Keller, *Making Sense of Life with Models, Metaphors, and Machines*, Chapter 7.

There are countless other references to the “inherent” connection between moving images and life by film theorists such as Bela Balazs (Balasz 1970), Jean Painleve (2000) Germaine Dulac (1978), and later of course by Deleuze (1983, 1985). The point is that Ries’ insights regarding the cinema are not restricted to the narrow confines of science cinema; they are a part of a larger conversation that involves scientists, filmmakers, artists, theorists, and critics, who all recognized the coincidence between the moving image and life itself, and who all deeply questioned the nature of that coincidence. Does the cinema replicate the movement of life (Eisenstein)? And if it does, then is the cinema itself “living” (nonorganic life in Deleuze)? Or might the cinema change and experiment with life (Painleve)? Surely neither Kracauer nor Bazin are the naïve realists that they are often accused of being.⁹⁶ But then what is the nature of the “life” to which the cinema provides unprecedented access?

To raise these points is simply to draw attention to the fact that the questions microcinematography raises is not exclusive to the sciences; rather, they collide in crucial ways with other histories of the moving image—including the histories of art and entertainment. Another Parisian, Jean Comandon, expresses this fact better than anyone: not only did he make important innovations in the field of time-lapse microcinematography, but he was also instrumental in popularizing the genre by exposing it to wider, non-scientific audiences.⁹⁷ Primarily concerned with diagnosing syphilis spirochetes by visually distinguishing it from other bacteria by their characteristic movement, Comandon turned to cinematography after being inspired by films of Brownian movement. In 1908 Comandon teamed up with Charles Pathe, from the company Pathe Freres, who allowed him to use the company’s technical equipment in exchange that his films would contribute to their catalogue of films—an effort on Pathe’s part to attract audiences. This

⁹⁶ See Daniel Morgan, “Rethinking Bazin: Ontology and Realist Aesthetics.”

⁹⁷ See Hannah Landecker, “Cellular Features: Microcinematography and Early Film Theory,”

partnership was successful on both ends. Films such as *The Movement of Leucocytes* were shown to, and popular among, mass audiences. And Comondon, for his part, was able to improve upon his own filmmaking, eventually building a single machine that allowed him to magnify and accelerate his specimens at the same time.⁹⁸

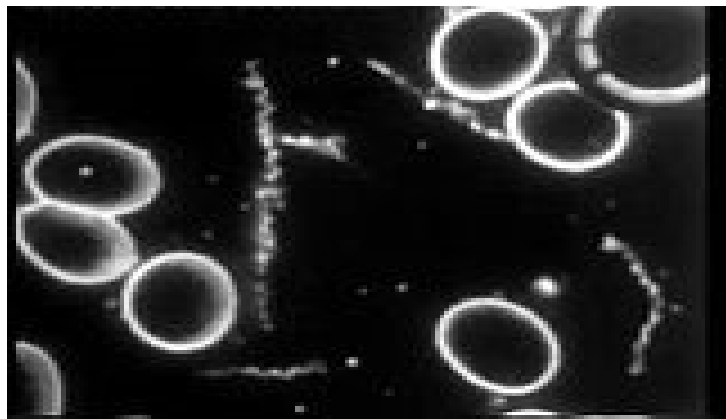

Figure 14: Jean Comondon film of syphilis using an ultramicroscope (c.1910).

There is not doubt that Comondon's films were reasonably successful among mass audiences, and even contributed to the larger discourse concerning the relation between life and the moving image. Landecker stresses, for example, that, "[t]he cellular film, an infinitely reproducible inscription of a continuous living movement rather than a set of histological stills, was a new form of narrative as well as a new set of aesthetic forms" (Landecker 2005: 912-913). Nevertheless, it's still unclear what the response among *scientists* was. Did this technology, which revolutionized popular entertainment, have the same effect on scientific epistemology? The Nobel-prize-winning surgeon and eugenicist, Alexis Carrel, for example, believed that his films of embryonic somatic cells living in culture were going to be instrumental to the formation of a "new

⁹⁸ See Landecker, "Cellular Features," 913, for a thorough description of the machine.

cytology” connected to the philosophy of Henri Bergson.⁹⁹ Indeed, microcinematography didn’t just demystify development, but it also expressed the temporal life force, or *duree*, which was the vital substance of all living forms. In this way, the cinema not only made breakthroughs in science, but also metaphysics. Obviously, there were a number of respected scientists using microcinematographic techniques, each of them realizing that the then standard histological methods of fixing and photographing specimens failed to capture change. But was the cinematograph, and all its accompanying practices, accepted in the scientific community the way photography was? In short, is cinematography an overlooked puzzle piece in the technical development of scientific epistemology?

The short answer is, no, the larger scientific community was deeply skeptical about the scientific value of these films. While Landecker notes in her article “Cellular Features,” that Comandon’s films “raised questions about narrative and meaning not just for film critics but for the scientific investigation of the relationship of structural elements and functional events in the microscopic world” (2005: 913), this is far indeed from claiming that they were embraced by the scientific community. In truth, Comandon’s films, as well as the other microcinematographic experiments, never saw anything close to the kind of acceptance that photography did within scientific communities.

But why? Surely the cinema allowed scientists to perceive the kind of change that the photograph eclipsed. Shouldn’t this have been sufficient to command the attention of the wider scientific community? Perhaps. But according to Peter Medawar in *Memoirs of a Thinking Radish*, scientists who used cinematography were “delighted, distracted, and beguiled by the sheer beauty of the cultivated cells,” and unfortunately this led them to miss the opportunity to “solve biological

⁹⁹ See Carrel, “The New Cytology,” especially, 298; and “Physiological Time,” especially, 620.

problems” (Medawar 1986: 63). Others simply distrusted the medium, and claimed that it created fictions, and that it could not be used for “good scientific work.” After screening one of Jean Comandon’s films on syphilis in 1910, outraged scientists exclaimed that cinema was not to be taken seriously – “entertainment for the ignorant,” one critic declared (see Painleve 2000). Thus, the cinema was by and large understood to be a medium for entertainment rather than for “serious” scientific research. According to Landecker and Kelty, this explains why microcinematography is largely absent from the annals of scientific epistemology (see Landecker and Kelty 2004).

Of course the pressing question here is: What assumptions about the cinema and scientific epistemology led scientists to discount the medium? A careful survey of the literature on microcinematography reveals a couple of things. The first is that in the early twentieth century, scientists were accustomed to studying “lifeless” specimens; and this is true in at least two ways. As we already noted, although chronophotography allowed scientists to gain a “sense” of change, change itself was absent from chronophotographic images. Landecker and Kelty cite Chevreton and Vlès, who explain that one

could not process the 7,000 to 9,000 stills just by looking at the static film strip; the film had to be run through a projector for its content to be graspable by the viewer. There was no other access to the phenomenon. It is movement itself, the movement-image—of film cells and organic cells—that makes life visible (Landecker and Kelty 2004: 38).

There is also another sense of “stasis” that had begun to take hold of scientists’ imagination: mathematical formalization. According to Daston and Galison, many scientists grew weary of the limitations involved in mechanically reproducing the physical world through photographic images, and sought objectivity by other means. Hence, the emergence of the “structural objectivists,” or those scientists—among them were Frege, Pierce, Russell, Helmholtz, Carnap, Plank, and Poincare—whose confidence in gaining an objective understanding of the physical world never faltered, but who sought to acquire it without the aid of images, or any “empiricism” for that

matter; they claimed that these methods were still too subjective. Instead, they were committed to “invariant structures” (see Daston and Galison 2007: 253-307). Indeed,

all [structural objectivists] upheld a version of objectivity (their own word) grounded in structures rather than images as the only way to break out of the private mental world of individual subjectivity. In their view, science worthy of the name must be communicable to all, and only structures—not images, not intuitions, not mental representations of any kind—could be conveyed to all minds across space and time” (254).

This general shift toward formalization and structure is the impetus for Medawar’s own critique of microcinematography. What’s at issue for Medawar is the need to formalize biological processes, instead of merely “observing” them. In this way, his concerns exemplify the larger desire in the biological sciences to generate theoretical models that can systematize and generalize—that can “axiomatize” biological systems.¹⁰⁰

Given that life’s stasis was served up in at least two ways—in the image and in invariant structures— it’s no wonder that the cinema was regarded with disdain: it presented life *in movement*. Observing change must have come as quite a shock.¹⁰¹

Of course these differences alone do not entail that microcinematography is an instance of nonrepresentational, and therefore, nonscientific imaging. As Landecker explains in great detail, microcinematographers were in every way committed to reproducing life’s processes in the image—indeed, the living cell and the film cell were thought to collide. In this way, representation was held in the highest of esteem. Life was a temporal process, so a time-based medium was

¹⁰⁰Botanist, Aristid Lindenmayer’s development of the Lindenmayer System, or L-System, is exemplary of this trend to formalize biology through his importation of Russell and Whitehead’s mathematical logic into biological systems. See Landecker and Keltly, “A Theory of Animation: Cells, L-Systems, and Film.”

¹⁰¹ One way of thinking about this is that the technology ushered in perceptual advancements that scientists were yet unprepared to incorporate into their practice. So for example, where early cinema goers experienced fright after seeing moving images for the first time—when Auguste and Louis Lumiere screened *L’arrivée d’un train en gare de La Ciotat* in 1896, urban legend has it that the audience was so frightened by the moving train heading toward them that they screamed and moved to the back of the room—likewise, scientific communities experienced outrage and deep skepticism because their research was set in motion for the first time, after having become so accustomed to static practices. Although microphotography brought organisms into plain sight, they were nevertheless dead, lifeless. See Landecker, “Cellular Features,” and Evelyn Fox Keller, *Making Sense of Life*, Chapter 7.

required to represent it. In this perspective, wouldn't the cinema be a more faithful witness to scientific representation than even photography? Rather than distracting viewers, wouldn't it turn our attention toward life itself as Kracauer had thought? Certainly the cinema wasn't about to change the minds of mathematical formalists—observation was a conversation stopper—but what about the more empirically minded scientists? Surely it trumped photographing dead specimens.

In his 1962 work, *New Patterns in Genetics and Development*, C.H. Waddington explains that,

Time-lapse films, of course, exaggerate the speed with which these movements are carried out...[but] the point they bring home so forcefully, that cytoplasm is always in a state of physical activity, is a perfectly valid one. [Such exaggeration is] useful to counterbalance our tendency to envisage cells in terms of the static pictures presented by ordinary microscope preparations (Waddington 1962: 154).

What Waddington notices here, is not simply that the cinema counterbalances stasis, but in order to do so, it exaggerates the time of “real process”—recall here that Ries condensed fourteen hours of sea-urchin development into a two-minute film. The point is that microcinematographic images were meticulously edited. Ries notes, for example, that

I had always to economize and not photograph until one could see a new phase of movement. . . . The penetration of the sperm and the formation of a fertilization membrane lasts some minutes, then an hour passes before the formation of the primary furrow. The division takes place again very quickly, then an hour elapses before the second segmentation, etc.; the smaller the cells become, the more the pauses shorten. Having observed, through subjective examination, the periodicity of the divisions, I could set into motion or stop the clockwork during the photography at the right time (translation in Landecker and Keltly 2004, Ries 1910: 227).

Ries does not present sea-urchin development in real-time; and if he did, it would have been almost imperceptible—far too slow to cognitively register.¹⁰² Ries is fully aware of this fact: manipulating the presentation of development is required in order to communicate pertinent

¹⁰² Comandon, for his part, became exclusively concerned with filming processes that were too slow to perceive. See Landecker, “Cellular Features.”

information about the “real process.” Time-lapse cinematography, Ries and others believed, could represent durations that were beyond human perception. This is why Carrel thought that microcinematography could even allow us to intuit Bergsonian duration (see above).

What I would argue, then, is that the skepticism over microcinematography was not simply a result of seeing biological research in motion for the first time—in sharp contrast to the stasis of normal research practices. It was also, and I’m tempted to suggest, more importantly, a consequence of the fact that microcinematography, unlike photography (and mathematic formalism, for that matter), required something different than a commitment objectivity. It required what Daston and Galison call, “trained judgment” that emerged well into the twentieth century. The problem, however, is that this kind of expertise (which I will consider in more detail momentarily), was not a core value for scientific practice until the mid-twentieth century. Scientific imaging was still entrenched in the ideals of mechanical objectivity when scientists voiced their skepticism over the scientific value of Comandon’s film on syphilis in 1910. In fact, such forms of intervention were indicative of the “aestheticism” that thrived in the nineteenth-century arts, and was weeded out of scientific epistemology. Where artists believed that nature was inert and lifeless without the subject’s feelings and emotions to vivify it, scientists thought these were naïve sentimentalities that idealized nature. I would argue that from the objectivist’s view, there are very few differences between Ries’ time-lapse techniques and the sentimental prose of a Henry James novel; each *interprets* and therefore *aestheticizes* nature. In this era of scientific visualization, aesthetics is strictly opposed to scientific representation, and the cinema is one such form of aestheticization.

What’s significant here is that Daston and Galison demonstrate how only few decades after Comondon’s harsh reception in 1910 that a new epistemic norm was beginning to take shape:

“trained judgment.” With the limitations of “mechanical objectivity” coming into focus by the mid-century (see above), this left room for scientists to erect new epistemic ideals to direct imaging practices. The forms of self-surveillance and self-restraint that were so lauded among nineteenth and early-twentieth-century objectivists began to fall out of favor with scientists by the mid-twentieth century. Scientists began to realize that full automation too often produced incidental details instead of relevant information; deeper patterns in nature were lost due to scientists’ self-abnegation. Thus, by the mid-twentieth century, a new epistemic virtue emerged to supplement (though not wholly replace) mechanical objectivity. Imagists believed that a particular kind of “trained scientific judgment” could be cultivated and thus mobilized to intervene in the reproduction of nature’s image. In other words, where the subject was formally bracketed, now it could be used in the service of nature, to bring out the deeper patterns that were lost, or in any case, obscured by the subject’s former commitment to self-restraint. A trained subjectivity was thus cultivated in the sciences in order to intervene in, and even exaggerate, what was mechanically reproduced so that many of nature’s deeper patterns could be categorized (see Daston and Galison 2007: 309-361).

Concretely, this transformation meant that the self no longer abnegated judgment, but rather sought to cultivate, or “train,” it through experience and familiarity with the object of knowledge. With such training, the patterns that normally went unnoticed could now be rigorously classified. Thus, where the nineteenth century idealized the “mechanical eye,” the twentieth century idealized the “trained eye.” For Daston and Galison, this contrast is perhaps most forcefully illustrated in Fredric A. Gibbs and Erna L. Gibbs *Atlas of Electroencephalography* (1941). There, in stark contrast to Christeller, the Gibbses explain that their “book has been written in the hope that it will help the reader to see at a glance what it has taken others many hours to

find, that it will help to train his eye so that he can arrive at diagnoses from *subjective* criteria” (2007: 321). What’s significant here is that the Gibbs’ atlas exemplifies an epistemic mutation: the “experienced eye” of the scientist is not simply tolerated but absolutely necessary for understanding nature’s deeper patterns. Where the untrained eye sees confusion, the trained eye sees deeper order. Thus, a new scientific self emerges in the twentieth century: he is no longer a humble or “modest witness,”¹⁰³ but a confident, self-assured expert who trains apprentices how to see. “The scientist of the twentieth century entered as an expert [who] could perceive patterns where the novice saw confusion” (328).¹⁰⁴

What’s striking, of course, is that Daston and Galison’s characterization of the “trained scientist” in the mid-twentieth century could hold true of microcinematographers such as Ries and Comondon in the early-twentieth century. Indeed, my central provocation here is that microcinematography did not find itself in the annals of scientific imaging (see Landecker and Kelty 2004) precisely because it came too early. In other words, microcinematography anticipated developments in scientific imaging and scientific epistemology more generally, but was unable to gain traction in scientific circles due to its unfortunate timing. In fact, the kinds of time-lapse techniques that Ries, Comondon, Carrel, and others were developing could not have been more focused on representing nature’s deeper patterns. However, mechanical objectivity would not suffice for this kind of research. New forms of cinematic editing were required to make life’s deeper patterns and processes perceptible to the untrained eye. In short, the trained scientist was necessary to exercise his judgment to ensure that Nature’s invisibility could be made visible.¹⁰⁵

¹⁰³ See Steven Shapin and Simon Schaffer, *The Leviathan and the Air-Pump*; and Donna Haraway, *Modest_Witness@Second_Millennium.FemaleMan_Meets_OncoMouse: Feminism and Technoscience*

¹⁰⁴ It is crucial to note here that “trained judgment” is not the same as “truth to nature”; there is a difference. Sequence matters. See Daston and Galison, *Objectivity*, 322.

¹⁰⁵ See Evelyn Fox Keller’s, *Making Sense of Life*, where she charts how visualizing the invisible depths of life was the impetus behind the development of new visualization technologies, especially in microscopy.

Thus, microcinematography is far indeed from being an instance of nonrepresentational scientific visuality; in some ways, it exemplifies representational values inasmuch as it anticipates its necessary development.

But if Daston and Galison help us to see how microcinematography is an unacknowledged precursor to a transformation in scientific representation, they fall short when it comes to demonstrating how this transformation might reflect wider political and economic shifts in power and value. At times, their otherwise meticulous text makes it seem as if the shift to “trained judgment” is just the next step on the way to representational success. As I mentioned in Chapter 1, this oversight is, I believe, a symptom of their tight focus on the history of science. And, yet, their neglect of the wider circuits of power may still seem surprising given that they devote considerable attention to showing how training scientists in the mid-twentieth century required considerable institutional reorganization so that students “internalized and calibrated standards for seeing, judging, evaluating and arguing” (Daston and Galison 2007: 327). Indeed, there was a proliferation of new educational institutions across Europe and North America during this period in order to train scientific subjectivities so that there could be a Nature to represent.¹⁰⁶ In other words, Nature or the Real was not found through the mechanical recording of it; rather, it was made possible by the trained eye. Indeed, Daston and Galison even argue that for this era of scientist, “the real emerged from the exercise of trained judgment” (355).

Now, while Daston and Galison pay lip service to Foucault in their Introduction, noting that they are indebted to his work on the “history of the self” (2007: 37), unfortunately they fail to invoke Foucault’s work when it seems most pertinent: that is, when it comes to identifying the very circuits of disciplinary power that coincide with the rise of industrial capitalism that are

¹⁰⁶ See Daston and Galison, *Objectivity*, Chapter Six, especially 325-327.

responsible for training subjects and their objects. In other words, what Daston and Galison describe without acknowledging it is how an image of Nature is produced out of the institutions and techniques used for disciplining professionals to generate it.¹⁰⁷ So while the language of discipline (see Chapter 1) is nowhere invoked in Daston and Galison's important study, it seems to me that the small corner of the scientific world they're describing is a symptom of what Foucault calls a disciplinary society: there is an institutional training and standardization of the scientist's physiological body, namely, his "eye," in order to give order to what otherwise has none.

I also want to suggest that my hypothesis of the "disciplined scientist," which complements and/or extends the notion of the "trained scientist," needs to be part and parcel of our description of the microcinematographer. This is not true simply by implication; rather, the overlap between early scientific cinema and disciplinary power constitutes an important part of Lisa Cartwright's exquisite study, *Screening the Body: Tracing Medicine's Visual Culture*. There, she pays careful attention to how, "at the turn of the century, the motion picture apparatus was crucial in the emergence of a new set of optical techniques for social regulation. In laboratory culture, medical practice, and beyond, we see the emergence of a distinctly surveillant cinema" (Cartwright 1995: xiii). In particular, she draws on what Foucault describes as the "penetration of the medical gaze into the interior of the body" to elucidate how the cinema was used in medical science to discipline the "uncontrollable field of the body" (ibid.). The idea that the biological sciences desire to penetrate the body through the "gaze," which is only enhanced through microcinematographic technologies (which she briefly considers in Chapter 4), follows more generally from Foucault's insight (which is deeply indebted to the work of Georges Canguilhem¹⁰⁸) that in the nineteenth

¹⁰⁷ See Foucault, *Discipline and Punish, History of Sexuality vol. 1* and *Society Must Be Defended* for his careful analysis of disciplinary power.

¹⁰⁸ See Georges Canguilhem's two lectures entitled, "The Concept of Life," along with other essays, especially, "The Epistemology of Biology" and "The Question of Normality in the History of Biological Thought." Canguilhem

century Life recedes into the “depths” so that “what matters is no longer identities, distinctive characters, permanent tables with all their possible paths and routes, but great hidden forces developed on the basis of their primitive and inaccessible nucleus, origin, causality, and history” (Foucault 1994: 251). “Life,” continues Foucault, “escap[es] from the general laws of being as it is posited and analyzed in representation. On the other side of all things that are...supporting them to make them visible... life becomes a fundamental force” (ibid. 278).¹⁰⁹

It’s not hard to see, then, why it is that microcinematographic techniques would have quenched the scientific desire to represent the invisible, even mystical, forces of Life. It produced a technology of visibility that disciplined, if unsuccessfully,¹¹⁰ the great mystery of life’s temporal development (see Landecker 2005). This is perhaps why Alexis Carrel allied his work on microcinematography with Bergson’s duration. And although Cartwright draws on a different archive of “microscopic motion pictures” than I do here, the general point she makes is the same one: namely, that the technology affords more than “a representation of imperceptible living processes” (1995: 82). “It is a mechanism,” she continues, “through which science reorganized its conception of the living body, ultimately rendering the physical body a more viewer-friendly site—but a site whose appearance was radically reordered to reflect the body’s new status as a mobile, living system” (ibid.).

reads the history of the biological sciences, extending to modern biochemistry and genetics, as a deeply Aristotelian. Even self-organization and regulation are, according to Canguilhem, Aristotelian. “It was Aristotle,” he writes in “The Epistemology of Biology,” “who coined the term ‘organized body.’ A body is organized if it provides the soul with instruments or organs indispensable to the exercise of its powers” (Canguilhem 2000: 80). This is connected to his remarks in “The Question of Normality” that, “[a] remarkable and interesting fact from the epistemological standpoint is the proliferation of the terms containing the prefix auto-, used today by biologists to describe the functions and behavior of organized systems: auto-organization, auto-reproduction...” (Canguilhem 1998: 141).

¹⁰⁹ The full quote from the *Order of Things*: “Perhaps for the first time in Western culture, life is escaping from the general laws of being as it is posited and analyzed in representation. On the other side of all things that are, even beyond those that can be, supporting them to make them visible, and ceaselessly destroying them with the violence of death, life becomes a fundamental force, and one that is opposed to being in the same way as movement to immobility, as time to space, as the secret wish to the visible expression” (Foucault 1994: 278).

¹¹⁰ See Evelyn Fox Keller’s history of visual science in *Making Sense of Life*, Chapter 7.

In his study of the rhetorical transformations of the life sciences, Richard Doyle devotes considerable attention to the (in)visibility of life, and argues that it is not until the rise of molecular biology that scientists believed that all of life's secrets were in full view—"that's all there is," according to one scientist (Doyle 1997: 14). Although the ideology of a "fully transparent life" would not grip scientists until later in the twentieth century, I would argue that allure of disciplining it through the motion-picture apparatus was firmly in place in the early-twentieth century. Indeed, Reis, Comandon, Carrel, and others all believed that the temporal development, which eluded previous generations of biologists, was now represented in the moving image. And it was only by means of a scientifically "trained eye" working in conjunction with a microcinematographic apparatus, and functioning as a technical-physiological circuit of power, that a coherency to development could be erected out of the murky depths of Life itself.

Now, the reason for taking this brief excursion into disciplinary power and the trained eye, is to show how microcinematography is not simply an early-twentieth century technology of representation (despite many scientific objections to it), but it is also a technology whose representational success depends upon its embeddedness in circuits of power that deem a particular image of Life or Nature capable of representation. As I noted at the end of Chapter 1, Nature is never a politically neutral set of entities that technologies are better or worse at approximating. Indeed, this naïve view, which unfortunately is still very much with us in the twenty-first century, fails to account for how representational success presupposes the networks of power that solidify a particular notion of Nature worthy of representation. The success of a representation is thus never neutral, and this is particularly true in the case of microcinematography. The take away point here is that microcinematography does not, in fact, provide us with a model for nonrepresentational

visual culture in the sciences; quite the opposite: it only testifies to how visual representation in science is tied to wider spheres of political and economic value.

2.3. The Nano

Although microcinematography ultimately exemplifies the values of representation in scientific visual culture, there are currently other forms of visualization that explicitly wish to undermine representation's firm grip on scientific epistemology. In fact, Daston and Galison argue that with advances in nanoimaging, new epistemic values are currently under construction, and they ones that are no longer guided by the norm of representation. While I spent some time undermining the veracity of this claim vis-à-vis digital imaging in Chapter 1, I now look at whether and how this holds true for nanoimaging—the domain, incidentally, that holds the greatest promise for them. As will become clear throughout this section, much like microcinematography in the early-twentieth century and molecular animation in the twenty-first century, nanoimaging is far indeed from upsetting representational epistemology in science.

Daston and Galison explain that while scientific imagists had, until very recently, been guided by the norm of representation, “toward the end of the twentieth century...that seemingly self-evident aspiration began to be edged aside” (Daston and Galison 2007: 382). Elaborating on what a number of humanities scholars have begun to recognize,¹¹¹ they argue that “[f]or many scientists pursuing nanotechnology, the aim was not simply to get images right but also to manipulate the images as one aspect of producing new kinds of atom-sized devices” (ibid.). What's crucial here is that microscopy (atomic force microscopy, specifically) is one of the key techniques

¹¹¹ See N. Katherine Hayles' edited collection, *Nanoculture: Implications of the New Technoscience*. See in particular Nathan Brown's essay in the collection, “Needle on the Real: Technoscience and Poetry at the Limits of Fabrication.” Also see Luciana Parisi, “Nanoarchitectures: the Arrival of Synthetic Extensions and Thoughts”.

used in nanotechnology—or the manipulation of matter with at least one dimension sized from 1 to 100 billionth of a meter (nanometer)—and marks a decisive break in the history of imaging values: the image no longer functions as a “copy” of an “original” nature, but helps reconstruct that nature. “Images began to function,” they go on to remark, “at least as much as a tweezer, hammer, or anvil of nature: a tool to make and change things” (383).

In all fairness, Daston and Galison don’t give sole credit to nanoimaging for changing the course of scientific epistemology. As we’ve already noted, they also suggest that online atlases, which enlist interactive graphics that allow the viewer to generate his or her own content, also have a hand in this transformation. Such “virtual images” are meant to be manipulated, explored, and transformed so that, at least in principle, one could generate an image that had never been seen before (2007: 385)—an image that is not a copy of an original. The Visible Human Project is the most explicit example of the new virtual atlas.¹¹² But in their view, the nanoscale manipulation, or “haptic images,” which produce a quantum-mechanical interface, most clearly testifies to the fact that images change nature instead of copying or reproducing it.

In the course of their analysis, they cite a number of instances of nanoscale imaging that showcase the way in which seeing the world and bringing it into existence are the very same process—seeing *is* fabrication. The most famous example they cite comes from 1990 when Don Eigler and Erhard Schweizer, both scientists at IBM, used a scanning tunneling microscope (STM) to write their company name at the atomic scale by manipulating 35 individual xenon atoms on a nickel surface.¹¹³

¹¹² http://www.nlm.nih.gov/research/visible/visible_human.html

¹¹³ For more on the nanomanipulation see Saw-Wai Hla, “STM Single Atom/Molecule Manipulation and Its Application to Nanoscience and Technology.” Also see Barbara Herr Harthorn and John W. Mohr’s edited collection, *The Social Life of Nanotechnology*.

Essentially, the STM operates by means of “quantum tunneling,” a phenomenon that occurs when a conducting needle (the tip is a single atom) comes into contact with a conducting or semi-conducting surface, and a current is established between them.

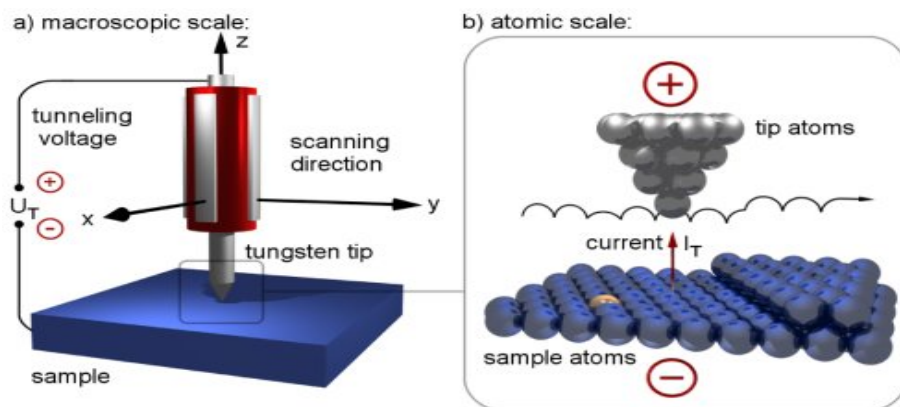

Figure 15: Scanning Tunneling Microscope via web search.

When the tip and the sample are brought less than 1nm from each other, a “bias” or voltage difference is applied between the two conductors; this establishes a tunneling current—in which electrons tunnel between the narrow vacuum barrier—that is a function of the distance between tip and sample. Ultimately, information is gathered—in image form—by monitoring the current as the tip scans across the sample, and adjusts its height according to the topography of the atomic surface. In order to relocate an individual atom across the surface of a sample (also known as Lateral Manipulation [LM]) as Eigler and Schweizer did, an incredibly fine control over the tip-atomic-surface interface is required. In short, when a certain minimum distance between tip and atom is reached—determined via the threshold tunneling current (I_t)—the atom moves underneath

the influence of the tip; and once the atom is in the desired location, the tip is retracted to its normal height so that the atom stays in place.¹¹⁴

Lateral manipulation using an STM demonstrates how seeing and making overlap at the nanoscale. Daston and Galison underscore how this new visual technology has led many scientists to care less about depicting what already exists and more about engineering what *could exist* (see Daston and Galison 2007: 397). In short, the haptic image ushers in a new regime of visibility—much like photography once did—but one without any precursors: the image is no longer tethered to the world that is, as it had been for centuries, and instead brings into being a new world.

What's crucial to realize is that nanomanipulation via the STM is a part of a much larger set of nanoscientific practices, which have captured the imagination of scientists and nonscientists alike. In very broad strokes, I now attempt to outline the nature of the epistemic assumptions that undergird these practices, if only to be able to map the (representational) values that STM manipulation—along with other nanoimaging practices—presuppose.

In Richard Feynman's address to the American Physical Society in 1959, he proposed that "There's Plenty of Room at the Bottom," and wondered "whether ultimately—in the great future—we can arrange the atoms the way we want; the very atoms, all the way down!" Less than thirty years later, K. Eric Drexler emerged as the inheritor of Feynman's dream. In visionary books such as *The Engines of Creation: The Coming Era of Nanotechnology*, *Nanosystems: Molecular Machinery, Manufacturing, and Computation*, and *Unbounding the Future: The Nanotechnology Revolution*, Drexler proposes global social and economic transformations that await us upon our full embrace of nanotechnology. For example, in *The Engines of Creation*, Drexler envisions

¹¹⁴ For a complete overview of nanomanipulation via STM see Saw-Wai Hla, "STM Single Atom/Molecule Manipulation and Its Application to Nanoscience and Technology."

futures in which miniature machines build the objects of our world, atom-by-atom, and the Library of Congress fits on a sugar-cube sized chip.

Such speculation has not escaped criticism, however. In her introduction to the edited collection, *Nanoculture: Implications of the New Technoscience*, N. Katherine Hayles writes that Drexler, despite his undeniable influence on the field of nanotechnology, is closer to the field's black sheep than its senior statesman. The most compelling reason for the scientific community's animosity toward him¹¹⁵ is that he simply "promises far too much with far too little experimental work to back up his claims" (Hayles 2004: 13). She explains that his predictions seem farfetched to other scientists, and resemble what lies in the pages of science fiction, rather than being based upon "reproducible and verifiable scientific fact[s]", which ensures the confidence of the scientific community and the wider public.¹¹⁶

Hayles also proposes another reason why Drexler's work may be less than appealing to some. Citing Victoria Vesna and James Gimzewski's important work,¹¹⁷ she notes that Drexler relies on a "mechanical" instead of a "biological" framework for describing manipulation at the nanoscale. In short, his mechanics, populated with devices such as pulleys, gears, and conveyer belts, are anachronistic, and are a remnant of industrialism that is not well suited to nanoscale intervention.

Now, whether the "mechanical" or the "biological" provides the "right" framework for nanoscience is a question that I'm not prepared to deal with here, and, frankly, it is one that I'm not inclined to deal with at all. I'm much more interested in how the mechanical framework

¹¹⁵ Hayles notes an incident at a scientific conference in which one scientist was so upset by the fact that he was sitting next to Drexler that he challenged him to a fistfight (Hayles 2004: 12).

¹¹⁶ Quoted from the Forward in *Scientific American* collection, *Understanding Nanotechnology*.

¹¹⁷ See Victoria Vesna and James Gimzewski, "The Nanomeme Syndrome: Blurring of Fact and Fiction in the Construction of a New Science."

functions within the discourse of nanotechnology, and far less interested in whether the framework gets it “right.” It is for this reason that I think Hayles is spot on when she writes that the biological and the mechanical are “metaphors”— “described as a forklift, kinesin sounds like a machine; described as part of the cell’s interior, it sounds biological” (Hayles 2004: 12)— rather than accurate descriptions of the physical world. But “[t]he choice of metaphor,” she continues, “is consequential, for it lays down a linguistic track that thought tends to follow and suggests connections that bind new ideas into networks of existing conceptual structures” (2004: 13).

While I more or less agree with Hayles’ understanding of the impacts of metaphor¹¹⁸ in the context of nanoscience, I’m also reluctant to see that the “choice” between metaphors is as simple as she presents it. Although there may be some outlying scientists, and many more cultural theorists and philosophers, who champion nanoscale manipulation using non-mechanical frameworks—Nathan Brown’s “poetics” of nanotechnology and Luciana Parisi’s “pure potentials” of “programmable matter” are exemplary here (see note 37)—what Hayles overlooks, or in any case, fails to emphasize, is how mechanical metaphors are a symptom of a nanoscientific culture that is increasingly defined by the values of engineers. This is precisely what Daston and Galison emphasize in their treatment of nanomanipulation, however. They explain that the difference between “pure” and “applied” science is disappearing in fields such as nanoscience, which is now largely driven by scientist-engineers who want to know whether their device “will function reliably under harsh conditions, [and whether it] can be mass-produced—whether they are building airplanes, magnetic memories, or, increasingly, things in the nano-domain” (Daston and Galison 2007: 393).

¹¹⁸ Although, Phillip Thurtle has suggested to me that the real problem with Hayles here is that she thinks of these as “metaphors” instead of “models.” This would require a more in-depth consideration of the relation between models and metaphors. See Evelyn Fox Keller, *Making Sense of Life: Explaining Biological Development with Models, Metaphors, and Machines*.

While it would be nearly impossible at this point to provide an exhaustive account of the “engineering ethos”—especially given the incredible diversity of engineering subfields—consider for a moment how The American Engineers’ Council for Professional Development characterizes the field. Engineering is

[t]he creative application of scientific principles to design or develop structures, machines, apparatus, or manufacturing processes, or works utilizing them singly or in combination; or to construct or operate the same with full cognizance of their design; or to forecast their behavior under specific operating conditions; all as respects an intended function, economics of operation or safety to life and property.¹¹⁹

According to this description, engineers concern themselves with the application of “scientific principles” to the design of systems (from airplanes to nano-objects), and operate under the auspices of having full knowledge of their design’s construction, as well as its present and future behavior in all possible contexts. In many ways, this is a more precise way of saying, as Daston and Galison do, that engineers want to know “will my device function reliably under harsh conditions?”¹²⁰ Of course one may object that Daston and Galison are reductive when they characterize nanoscience in this way, especially given the incredible diversity of activities that make up the science today—including fields such as surface science, chemistry, molecular biology, physics.¹²¹ In fact, the National Nanotechnology Initiative says that nanotechnology covers all manipulations of matter with at least one dimension at 1 to 100 nanometers,¹²² which suggests that it is hardly an easy set of practices to characterize.

And, yet, despite the overwhelming breadth of the field today, there are two generally agreed upon approaches to nanofabrication: “bottom up,” which concerns itself with the self-

¹¹⁹ <http://www.abet.org/History/>

¹²⁰ And as I have written elsewhere, the ethos of the device-oriented work of engineers pervades other technoscientific fields as well, especially synthetic biology—a field in which the entire goal, according to Rob Carlson, is to apply the principles of engineering to biological systems (Carlson 2010: 83-86).

¹²¹ See Ratner and Ratner’s *Nanotechnology: A Gentle Introduction to the Next Big Idea*.

¹²² <http://www.nano.gov/>

assembly of devices; and “top down,” which involves the fabrication of nano-objects from larger objects.¹²³ In other words, “top-down” and “bottom-up” describe nano-fabrication from two different directions.¹²⁴

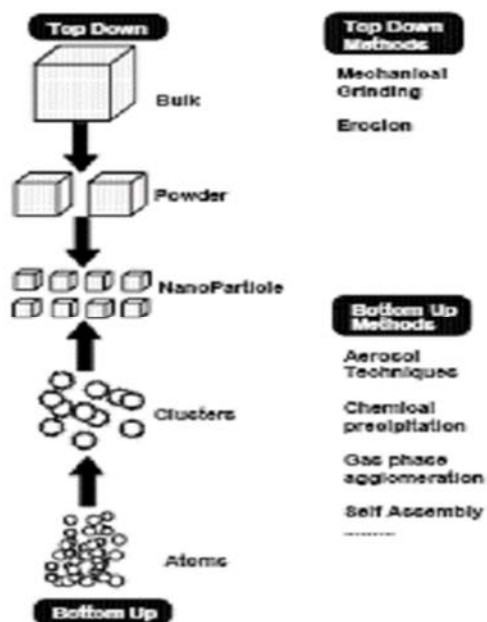

Figure 16: Representation of bottom-up and top-down approaches to nanotechnology attained via web search.¹²⁵

Now consider some of the subfields that are spread across both directions of fabrication: nanoelectronics, nanomechanics, molecular scale electronics, nanorobotics, programmable matter; and the concepts used to describe matter at this scale of intervention: nanomotors, nanocars, machines, assemblers, devices, and so on.¹²⁶ The engineering ethos is undeniable here, and one

¹²³ See Parez Iqbal et al., “Nanotechnology: The “Top-Down” and “Bottom-Up” Approaches.”

¹²⁴ Once again, parallels the approaches taken in synthetic biology. See Mark A. Bedau, “Artificial Life.”

¹²⁵ http://www.gitam.edu/eresource/nano/nanotechnology/synthesis_and_processing_of_nano.htm

¹²⁶ For a good introduction engineering and nanotechnology, see Ratner and Ratner’s *Nanotechnology: A Gentle Introduction to the Next Big Idea*.

quickly comes to realize that Drexler's conceptual framework looks far less like an anomaly, as Hayles seems to suggest, and much more like the norm.

These observations only scratch the surface, since there is little here that tells us why the engineering ethos is in place. In other words, why is it that engineers, rather than biologists, define the values of those who manipulate matter at the nanoscale? The short answer is that these values are necessary for the continued flourishing of the field. And this evidenced in at least two ways. According to the IRGC's (International Risk Governance Council) 2007 Brief on Nanotechnology Risk Governance, one of the most worrisome aspects about the science is that

[a]t the nanoscale, the physical, chemical, and biological properties of materials differ in fundamental and valuable ways from the properties of individual atoms and molecules or bulk matter. Downsized material structures of the same chemical elements change their mechanical, optical, magnetic and electronic properties, as well as their chemical reactivity, leading to novel applications for industry, health-care and consumer goods. The same novel properties that may provide benefits to society also raise concerns about how nanomaterials may interact with human and other biological systems. A major concern is that the techniques to measure, predict behaviour and control particles, devices and systems at the nanoscale are still relatively immature, and therefore their long-term impacts are unpredictable (IRGC 2007: 6).¹²⁷

In short, the properties of matter are different at the quantum scale than they are other scales.¹²⁸ So for example, a stable material, such as aluminum, turns combustible in the quantum realm. Thus, changing matter at the nanoscale may lead to unpredictable effects at the macroscale. Put another way, "truly emergent" behavior, as the philosopher of science Mark A. Bedau puts it, is an unacceptable consequence, since emergent phenomena become "uncomfortably like magic," and cannot be anticipated and thus controlled (Bedau 1997: 377).

¹²⁷ <http://www.irgc.org/issues/nanotechnology/nanotechnology-risk-governance/>

¹²⁸ Phillip Thurtle has suggested to me that it is incredibly difficult to think of biological values at a single scale, since "biological values come about with the linking together of scales" (in conversation with Thurtle, February 14, 2015). This alone might be a reason to support a form of "biological thinking" within nanoscientific fields.

The risks involved when shifting between scales is therefore a central concern for policy makers, and is reflected in IRGC's recommendation for scientists:

A greater proportion of both public and private R&D funds should be targeted at better understanding how to characterise, assess, and manage risk related to the production, application, exposure to and disposal of nanomaterials and products. Ideally, a precautionary approach to widespread application is needed with research efforts directed towards closing existing knowledge gaps and developing fast and responsive early warning and monitoring systems (16).

Maximal control over the device or system fabricated, which includes knowing in advance how it will interact with larger systems, alleviates risk. And engineering-based metaphors are those that most explicitly instill the confidence that the nano-object constructed will operate predictably—with the reliability of a *nanocar* or a *nanomotor*— and will not generate any surprising deviations, or “truly” emergent effects. These metaphors inspire confidence. Even Hayles notes that inspiring confidence in the control over a system is the decisive advantage of Drexler's mechanist outlook:

What Drexler gains through his mechanical metaphors and imagery is the connotation that nanomaterials can be engineered, built, and controlled, as are mechanisms; what he loses is the connotation of dynamic change, mutation, and evolution characteristic of living matter. The subtext for his metaphoric choices centers on issues of control, for it is precisely the prospect that nanotechnology can replicate uncontrollably that is the greatest fear surrounding its development. By emphasizing the mechanical, he not only suggests that this technology can and will be constructed; he also minimizes the biologically-inflected implication that it may follow an agenda of its own independent of its creators' purposes (Hayles 2004: 13).

The second (and related) reason why an engineering-based ethos characterizes the values of nanotechnologists is the growing nanoeconomy. To understand this connection, note that the largest market share of nanotechnology patents are owned by cosmetics companies (L'Oreal owned the most as of 2011), though pharmaceutical companies are not far behind.¹²⁹ L'Oreal, for example, is the founding member of the International Council on Nanotechnology (ICON), an

¹²⁹ See Kaur and Agrawal, “Nanotechnology: a new paradigm in cosmeceuticals.”

organization that now includes Du Pont, Intel, Lockheed Martin, Mitsubishi, and other corporate giants. ICON describes itself as “technically driven” organization with “multi-stakeholder partnerships and governance, with members that span the globe, [which] make[s] it uniquely positioned to ensure global coordination and cooperation in nanotechnology risk management.”¹³⁰

What this tells us is that the growing nanoeconomy drives the vast majority of research and development in nanotechnology. Hence, the engineer’s commitment to fabricating novel systems and devices is of crucial importance to research and development in a nanoindustry. But what’s equally important to this growing economy is safety and risk management. Indeed, part of ICON’s core mission “is to ensure global coordination and cooperation in nanotechnology risk management.” In this way, the nano-engineer’s commitment to fabricating predictable and reliable systems (as we saw above) is deeply important to nanoeconomics.

This should not be mistaken for benevolency, however. For example, during the 2010 L’Oreal Melbourne Fashion Festival, the environmental, group, Friends of the Earth (FOE), staged a major protest against the use of unsafe nanoparticles in cosmetics and sunscreens. These protests were not unfounded in research: Amanda Barnam, oddly, one of the recipients of L’Oreal’s 2008 Women in Science Fellowship, published a paper in *Nature Nanotechnology*, that argues that titanium dioxide nanoparticles used in sunscreens produce free radicals that are dangerous. In June 2010, three months after the protests, L’Oreal issued a brief report titled, “The Use of Nanotechnologies in Cosmetology.” A large portion of the report is devoted to the safety and *actual* risks involved with the technology. It’s worth quoting the report at length:

An experimental model of eco-toxicity that makes it possible to test nanomaterials under conditions approaching the real world has been developed by L’Oréal. Indeed, when studying risk it is necessary to be as wary of false assurances as of false alarms generated by limited studies, carried out in test-tubes under extreme artificial conditions. The latter can certainly sometimes inspire original theoretical reflections, but too often give rise to

¹³⁰ ICON website: http://icon.rice.edu/about.cfm?doc_id=4380.

outrageous extrapolations in terms of health risk that are subsequently relayed by the media. L'Oréal believes that while any new technology must be developed and applied taking all the precautions necessary to minimise the possible risks, one must also allow researchers to optimise the benefit of scientific innovation in the interest of the public and the environment. Thus one cannot overstate the need and the importance of an international consensus that includes civil society participation for the development of standards for nanotechnologies that are relevant and adapted to the various industrial sectors.¹³¹

The take away is that risk management and predictability, both core values of engineers, concern the stakeholders in nanotech research and development; but these concerns never overshadow the flows of capital. The language of the report is particularly strong in this regard: “L'Oréal believes that while any new technology must be developed and applied taking all the precautions necessary to minimise the possible risks, one must also allow researchers to optimise the benefit of scientific innovation...” And of course it is no secret that the “benefit of scientific innovation” is profit. Hence, they end the report noting the importance of developing an international consensus for nanotechnology standards “that are relevant and adapted to the various industrial sectors.” In other words, a cosmetic giant such as L'Oreal is willing to invest time and money into public and environmental safety, especially in the wake of serious protests that could threaten their stake in a growing industry, but it seems clear that this is a tactic meant to pacify alarmists and ensure that steady accumulation of capital.

Thus, to return to our initial point, it's hard to deny Daston and Galison's claim that the ethos of engineering has greatly influenced the culture of nanotechnology. My sense, however, is that “engineering values,” as opposed to other scientific-value systems (*pace* Hayles), can be easily translated into market interests, which is why they predominate in nanotechnology today. What worries me, however, is that Daston and Galison seem to think that the predominance of engineering values is what makes representation irrelevant. To understand what underlies this

¹³¹ <http://sustainabledevelopment09.loreal.com/pdf/topics/Cosmetology.pdf>.

claim, and how it fails to appreciate the importance of representation for nanoimaging, we need to get a better sense of what they mean by representation.

Unfortunately, although Daston and Galion offer a lengthy and compelling treatment of the myriad ways in which “truth,” “objectivity,” and “judgment” function in scientific epistemology, their treatment of representation, which in some ways undergirds their entire project, pales in comparison. Given what they do say, we can safely assume that representation refers to the *re*-production of an original. They explain that “[r]epresentation is always an exercise in portraiture, albeit not necessarily one in mimesis. The prefix *re*- is essential: images that strive for representation present again what already is. Representative images may purify, perfect, and smooth to get at being, at ‘what is’” (Daston and Galison 2007: 382). According to this description, representation makes an ontological claim: it presupposes the existence of an original that it then copies, though imperfectly. Of course this understanding of representation is virtually ubiquitous in the history of ideas and finds *its* origin in Plato. Recall that for Plato, the “original” is the thing that most resembles itself, and it is characterized by its self-identity; while the copy is the “appearance” characterized by its deficient reproduction of the original. What’s important for Daston and Galison is that representation is based on a logic of resemblance. Armed with this notion representation, it’s clear why they think that the quantum-mechanical interface of the STM, which manipulates physical reality as it visualizes it, challenges the primacy of representation. “In this corner of science,” they insist, “the representation of the real—the use of images to finally get nature straight—may be coming to a close (2007: 392)—“ontology is not of much interest to engineers” (303). Nanomicroscopy doesn’t aim to replicate a quantum realm, but strives to reconstruct it.

What's crucial to realize about this reconstructive imaging practice, however, is that it is not value free: nanoimaging is shot through with the values of engineer-scientists and the systems of political and economic power in which they are embedded. What this means concretely is that the quantum-mechanical interface is not a presuppositionless or neutral encounter, but it is laden with the values a particular political economy that guides the reconstruction of the "real." With this remark, I can already hear the cries of Continental philosophers working under the loose banner of "Speculative Realism" (SR) objecting to my human-centered treatment of quantum-scale phenomena, which care nothing for humans. I would imagine that the most vocal among them would be Levi Bryant, who would claim, much as he does in his recent work *Onto-Cartography*, that I have managed to strip agency from non-human entities, and have given it right back to the human subject.¹³² What arguments such as this, and there are many of them now,¹³³ often forget in their enthusiasm for proclaiming the so-called "democratization" of all things—where there is no ontological hierarchy among humans, trees, solar systems, and quantum objects—is that political and economic circuits of power, which redistribute human and nonhuman actors alike, are part and parcel of any robust account of the nanoscientific world. Thus, to account for how (neoliberal) value systems play an integral part in the construction of the nanomanipulated world is deeply compatible with recent work in SR and OOO, even if those who currently subscribe to the label would most likely sneer at it.

It should also be noted here that I'm not rejecting those theorists who find something to champion in nanotechnology. So for example, I agree with Luciana Parisi when she forcefully demonstrates that

¹³² See Levi Bryant's introduction to *Onto-Cartography: An Ontology of Machines and Media*.

¹³³ See Bryant *Onto-Cartography: An Ontology of Machines and Media* and *The Democracy of Objects*; Graham Harman, *Guerilla Metaphysics: Phenomenology and the Carpentry of Things*; Jane Bennett, *Vibrant Matter: A Political Ecology of Things*.

by entering the realm of pure potentials--of color, shape, roughness, electricity, vectoriality, etc.--programmable matter promises an architecture of instantaneous realization of potentialities... At work here no longer is control intended as the calculation of the future by means of prediction, or the calculation of the unknown through pre-set probabilities. The disappearance of bio-physical contingencies instead is directly proportional to the nano-programming of uncertainties as the inclusion of fuzzy states in the design of thought and extension”” (Parisi 2012: 39).

Heavily influenced by the metaphysics of Deleuze and Guattari, Parisi sees deep affinities between nanodesign and overcoming the idea that we know in advance “what a body can do” (see Deleuze and Guattari 1987: 257). The problem here is not that Parisi fails to think about the deeper ontological potentials of nanodesign—quite the opposite, in fact. Rather, what’s worrisome is that cultural theorists and philosophers often fail to differentiate between the speculative values of philosophers who think about technoscience and the shared values of scientists who work in the fields of technoscience. Thus, given the ethos of engineering and entrepreneurialism that permeates nanotechnology *in actual practice*, I would argue that nanoscientists actually do strive to know in advance *what a body can do*. Far from releasing the “singularities of matter” in the metaphysical sense, technoscience seeks to maximize control (in the political and economic sense) over the novelties generated from nanofabrication. The novel materials and processes used to fabricate them are not value neutral, but they are a part of a neoliberalized economy of production, a control society, that seeks to turn every material and immaterial portion of the planet into a source of economic value.¹³⁴ Nano-scale fabrication certainly does not escape this logic; rather, it is booming sphere of accumulation. For instance, global revenue for nano-enabled products grew from \$731 billion in 2012 to more than \$1 trillion in 2013; and the United States alone made up \$318 billion of those dollars in 2013.¹³⁵ But what’s crucial to understand is that even the failure of

¹³⁴ See Neil Brenner’s work on “planetary neoliberalization”: *Implosions/Explosions: Towards a Theory of Planetary Urbanization*.

¹³⁵ See NSF http://www.nsf.gov/news/news_summ.jsp?cntn_id=130586

certain nano-enabled products, should that ever happen, is also an opportunity for capital. This requires some further explanation.

What seems to distract thinkers who champion the technology, or in any case, see in it radically new potentials for scientific practice, is that it fundamentally re-arranges matter—indeed, it creates novel combinations at the atomic scale that are not given in advance, at least in principle. This is what seems to intrigue Daston and Galison, inasmuch as it frees scientific epistemology from the grips of representation: nanoimaging is a visual construction of the nanoscale world that is not causally determined. Nanoimaging exploits the uncertainties dormant in the atomic world, and brings about a new world. Visuality is at the center of this material reconstruction, and science merges with artistic creation. For them, technoscience and aesthetics are no longer in opposition (as they once were), but are one and the same: scientific images are no longer “competing with art or even employing art but positioned as art itself” (Daston and Galison 2007: 384)

But as any careful study of twenty-first century political economy will show, which Daston and Galison’s work fails to draw on, the control society thrives on novelty, uncertainty, unpredictability, and even disaster. Milton Friedman, the grandfather of free-market fundamentalism, believed that disasters and uncertainty are necessary, and even a prerequisite for the global spread of capital:

Only a crisis—actual or perceived—produces real change. When the crisis occurs, the actions that are taken depend on the ideas lying around. That, I believe, is our basic function: to develop alternatives to existing policies, to keep them alive and available until the politically impossible becomes politically inevitable” (Friedman 1982: ix).¹³⁶

¹³⁶ Also see Naomi Klein’s *The Shock Doctrine*.

And those ideas that are “lying around” are free-market ideas, ideas that become “inevitable” once disaster strikes. This is the “shock doctrine” that Naomi Klein describes in her excellent book that bears the same name, and is a cornerstone of free-market fundamentalism.¹³⁷

What this tells us is that it is not simply the reliable nano-enabled products that are profitable, but so are the public and environmental disasters that they could generate. In this way, capital is not only invested in the reliability of nanoscale manipulation, that is to say, its predictability and safety for general use (or what concerns engineers), but it is also invested in the very ontological instability, novelty, and unforeseeability that the technology exploits—or in other words, all of those characteristics that cultural theorists and philosophers champion. Thus, if L’Oreal seemed dismissive of certain environmental concerns (see above), one reading of this is that it is because the flows of capital do not care about sustainability, or even the continued existence of L’Oreal, since it knows that disaster and crisis may be even more profitable. The deeply posthuman dimensions of capital become abundantly clear.¹³⁸

What also becomes clear at this point is that the value of a nanomanipulation is, by and large, determined by its value for the free-market.¹³⁹ In other words, nanotechnology is valuable insofar as it is recognized in terms of the ultimate value: market fundamentalism. If we now put this in terms of our discussion of Daston and Galison’s work on nanotechnology, there are at least two reasons why nanotechnology’s control by market forces is not seen as form of representation. The first, and by now familiar, reason is that they fail to look past internalist histories of scientific epistemology. The second, and perhaps more complicated, reason is that they do not have a robust

¹³⁷ In her book, *The Shock Doctrine*, Klein provides a number of examples of how this works, from Hurricane Katrina to the War on Terror.

¹³⁸ See Rosi Braidotti, *The Posthuman*.

¹³⁹ See Luigi Pellizoni’s unpublished work, “The Normativity of Nanotechnology: A Sociological Perspective: http://www.ciga.unipd.it/upload/73-News/att_pellizoni%20-%20rovigo%20workshop%20nanonorma_1.pdf”; also see his (along with Marja Ylonen) compelling article on neoliberalism and technoscience, “Hegemonic Contingencies: Neoliberalized Technoscience and Neorationality.”

understanding of representation. Indeed, I'm tempted to suggest that even if they did take stock of how market fundamentalism operates in nanotechnology, they would fail to see the technology as representational. For them, representation in the visual field is based on notions of visual "resemblance" and "similarity" (see above), which leaves no room for the "dissimilar" and the "unique" to be representational. In other words, when flexibility, novelty, and originality is normative, as it is today, our understanding of representation needs to become more sophisticated. Indeed, nanomanipulations, even though they produce novel material arrangements, are recognized in terms of an original value.

The relevancy of Deleuze's understanding of representation in *Difference and Repetition*, which we drew on at the end of Chapter 1, now comes into sharp relief. Even the production of difference, as we see today with the proliferation of nanoproducts, must be recognized, which is to say, *identified*, in terms of another thing, or value. The larger point here is that Deleuze's work demonstrates how representational logic is still operative in nanoscience. The proliferation of material differences at the nanoscale is still recognized in terms of a presupposed value ("ah yes, the flows of capital recognize that!"), which subsumes those differences under identification and therefore representational thinking. Deleuze thus gives us firmer theoretical basis for understanding how representation is still operative in neoliberalized technoscience. What we gain from this excursion into the persistence of representation in the nanoeconomy, is not only a deeper appreciation for how representation continues to guide the visual culture of science (instead of disrupting it), but also a richer sense of how today's visual technosciences—from molecular animation to nanoimaging—face similar uphill battles against the neoliberal control of the image.

In the course of this chapter I have brought together two disparate moments in the history of scientific imaging. What's intriguing about these otherwise unrelated practices, and thus makes their pairing instructive, is that they have each been called "nonrepresentational" by the wider scientific community: where microcinematography was once accused of being nonrepresentational; nanoimaging, by contrast, is currently championed for upsetting the dominance of representation. But in each case, representation, upon much more careful scrutiny, is shown to be what gives these images meaning for scientists. As such, both instances serve to demonstrate, rather than to undermine, the firm grip that representational values have on imaging practices. Put in other terms, representation is foundational for what Deleuze and Guattari might call the scientific "image of thought." As they explain in *What is Philosophy?*, an image of thought is "the image thought gives itself of what it means to think, to make use of thought, to find one's bearings in thought" (1994: 37). And for scientists, representation is precisely the horizon that gives these images meaning, that allows thought to "find its bearings," and make sense of them.

And what's more, it has also been shown that in each instance of scientific imaging, representation presupposes a notion of Nature that is constructed through wider circuits of political-economic power. In the case of microcinematography, the representation of Nature is inseparable from the disciplinary training of the professional scientist who makes it possible for there to be a nature to represent. And in the case of nanoimaging, market fundamentalism constructs an image of Nature—or in any case, what needs to be represented—that is reflected in each nanomanipulation. In this way, we also witness two crucial, if overlooked, ways in which regimes of power capture scientific visual culture.

An important corollary emerges from this discussion, however: both microcinematography and nanoimaging are accused of falling outside of representation precisely to the degree that they

incorporate *aesthetics* into their practice. When microcinematography emerged in the early twentieth century, objectivity was the reigning epistemic virtue of the day, and human intervention, of any kind, was thought to be an aesthetic addition that took away from an image's ability to represent (thus aesthetics and subjectivity were deeply entwined in this era). As we have seen, mechanical objectivity emerged as a response to the "artistic self" whose interpretations were projected onto nature. This self was cultivated and flourished in the nineteenth-century arts and was cancelled out by objectivity, point-by-point. Thus, the interpretive additions that the cinematic apparatus introduced exemplified forms of aestheticization, and even an "artistic self," which was in every way opposed to the norms that upheld representation in early twentieth-century science. To the extent that microcinema was believed to be nonscientific or nonrepresentational is also the extent to which it was believed to be aesthetic. And, yet, in hindsight, it's clear that this understanding of the aesthetic is far indeed from shedding its representational baggage.

Nanoimaging, on the other hand, is currently celebrated for not only freeing itself from the replication of a pre-existent "real," but also for reconstructing what counts as "real." At first glance, then, nanoimagists seem to adhere to values that couldn't be further from the ones that fated microcinematographers to being "nonscientific." For Daston and Galison, this fact exemplifies just how radically scientific values have changed in the last hundred or so years: where aesthetics was once the object of scorn, it is now embraced as the future of scientific imaging: "Finally, freed from the asceticism of objectivity or even the interpretation of trained judgment," they explain, the nano-image slides "more easily into an artistic presentation"; this so much the case that nanoimages aren't "competing with art or even employing art but positioned as art itself" (2007: 384). But even if this combination of seeing and artistic making is embraced by some scientists—

which situates nanoimages at the “blurred edge of science and art” (2007: 385)— it is still not sufficient to free the image from being captured by the neoliberal economy of representation.

This means a few things in terms of my larger project. Although neither imaging practice is able to serve as the benchmark for nonrepresentational imaging, the combination of the two is nevertheless instructive: in both cases, the aesthetic is thought to undermine representational epistemology in science, but fails to do so. This raises a further, and absolutely crucial set of questions: Can there be a nonrepresentational *scientific* visuality? And if there is, how precisely would it overcome the lure of representing a political construction of Nature? Given that aesthetics seems to have consistently posed a challenge to scientific representation, does aesthetics hold the key to overturning representation? And if so, wouldn't it also have to be a political-aesthetic project? But then wouldn't this political-aesthetics have to be nonscientific, given the stronghold representation has over scientific epistemology? It is with these questions in mind that I now turn to a forgotten filmmaker in the annals of scientific visuality: Jean Painlevé.

Chapter 3: The Scientific Avant-Garde

3.1 Two False Starts, or A New Research Trajectory?

In many ways, Chapter 2 has laid the necessary groundwork for a serious discussion of aesthetics and scientific representation to take place. Although my examples from microcinematography and nanoimaging may have appeared at first to be nothing more than two false starts for a genealogy of nonrepresentational visual media—that is, they are each incapable of overcoming or subverting the logic of representation that they seemed to be able to—they are also key moments in the history of scientific visual culture inasmuch as they expose how representation is not an inflexible mold, but it evolves, and it is capable of adapting to new circumstances. So for example, while many scientists in the early twentieth century thought that microcinema posed a serious threat to scientific representation, this is only insofar as representation is thought to be unable to accommodate the careful intervention of the trained scientist. But as we have seen, representation adjusts to the political and economic circuits of power that determine the form of Nature that is worthy of scientific representation. In this way, certain eras of scientific representation required the scientist's intervention (microcinema), while the contemporary era of representation requires image and reality construction to become indistinguishable processes (nanoimage).

But before we can begin to interrupt the neoliberal control of visual representation in our current epoch, we need to get clear on (1) the conditions under which an outside to scientific representation can be thought at all, and (2) whether such an outside is even possible within scientific epistemology, given that representation seems to reterritorialize every example of nonrepresentational resistance?

Chapter 2 paves the way for our research in yet another way, since one of the key takeaways from our discussion there is that aesthetics poses a challenge to representation in scientific visualization. As we saw, both the micro- and the nano-image were thought to marshal in a challenge to the guiding assumption of scientific epistemology due to their strong ties to aesthetics. But once again, we discovered how representation was not impeded or thwarted, but proved to be even more flexible and adaptable than previously thought. In short, representation became more and not less pervasive—even capable of reconciling itself with its so-called “aesthetic outsiders” in the twenty-first century. I thus ended Chapter 2 by asking whether there is a visual aesthetics that could ever open scientific epistemology up to an outside that is unable to be resolved in terms of representation. This is an especially daunting task given my hypothesis that today’s scientific representation obeys the norms of flexibility and reinvention championed by twenty-first century neoliberalism. It is not necessarily enough, in other words, to champion technoscientific novelty, recombination, and reinvention to undermine today’s representational logic in technoscience, since it would seem that each of these can be recognized in terms of, or in any case, be made to conform to, market values.¹⁴⁰

In Chapters 3 and 4, my argument will further test the hypothesis of an “aesthetic outside.” But in order to do so, it will have to take seriously Deleuze’s careful assessment of the logic of representation from *Difference and Repetition*. Drawing on Deleuze’s insights, we saw that representation is not a simple habit of thought to undermine through visual media (despite, perhaps, the perception in some domains of science and technology studies). Time and again we have seen how visual media in science are supposed to confirm what thought already recognizes.

¹⁴⁰ For an account of the way in which spheres of value that were once outside of the capitalist modes of production—including forms of novelty that are deeply destructive—have now been incorporated into the capitalist value production in the neoliberal era, see Luciana Parisi and Tiziana Terranova, “Heat-Death Emergence And Control In Genetic Engineering And Artificial Life.”

They are regarded as mere “channels” to communicate what is already known, instead of propelling thought toward what it doesn’t recognize, toward what is outside the coordinates of the “origin-copy” model produced through different circuits of political power.

Of course, developing a scientific aesthetics that is not beholden to this logic seems like a lot to ask of scientific epistemology, and it is no wonder that the media forms we put our confidence in to undermine representation came up short. Surely the kind of media aesthetics that I’m proposing is “ideal,”¹⁴¹ and would not authorize confidence among scientists, since it would propel thought toward what can’t be explained by pre-given categories. The very idea of a science that builds upon previous discoveries—the “accumulative epistemology” so pervasive today (cf. Stengers 2011)— would be undermined. In this way, the speculative hypothesis that I have formulated for myself is both more difficult and more radical to think than initially assumed. This leads me to a series of questions. If science is unable to accommodate such an aesthetic transformation of its epistemology, then where is such a challenge going to come from? From outside of science? Surely there is long and rich tradition of critiquing representation in the visual arts—especially within the European avant-garde—but under what conditions can the avant-garde talk, with any real specificity, about the sciences? After all, is the avant-garde all that helpful for the working biologist when the former is not able to speak concretely about the commitments and observations that animate the latter’s practice?¹⁴²

¹⁴¹ I do not use “ideal” in the pejorative sense, however. As will become clearer below, I use ideal in the sense that Deleuze uses it to describe the virtual: ideal but fully *real*. See Deleuze, *Difference and Repetition*, Chapters 3-4.

¹⁴² Of course, finding such an artistic practice would then give real credence to the idea that aesthetics can operate as a “minor science” in Deleuze and Guattari’s sense. There are traces of this thinking throughout their work, but especially in *A Thousand Plateaus*, when they show how minor science requires a “cosmic artisan” (see Deleuze and Guattari 1987: 411). This idea will be further reinforced when I argue in Chapter 4 that Deleuze develops an aesthetic ontology. In other words, science just *is* an artistic practice that is not cognizant of itself as artistic. The implication of my discussion below, however, is that insofar as science undergoes a “becoming-artistic” then it ceases to be scientific in the Royal, which is to say, generally accepted, sense of the term.

This leads me to my next question: What is the value of discovering an aesthetic outside anyway? Recall here that what propelled our investigation from the outset was the critical urgency of discovering a genealogy for scientific visibility that does not require representation for its legitimation. Drawing heavily on Deleuze's notion of the control society, I argued in Chapter 1 that animation is sutured to representation through neoliberal political and economic systems of value. Thus, at stake in this genealogy is redrawing the connection between the epistemic and political and economic spaces by means of a new understanding of visual media's role within scientific practices.

To achieve this goal, my suggestion is to expand our archive of image media in Chapters 3 and 4 to include not only those visual practices that scientists deem worthy of esteem (images that inevitably seem to find their way back to strengthening representation), but also those practices that scientists are unlikely to give a second thought. These are visual practices that have often been labeled "experimental" or "avant-garde," and are not a part of the annals of scientific imaging per se. I will contend, however, that they are no less "scientific" in their subject matter. I argue that their images are just as concerned with visualizing "natural phenomena" as their more scientific counterparts—molecules, morphologies, habitats, etc.—but in the end frustrate the pervasive habit of thought that would propel them toward scientific esteem: namely, representational epistemology.

I will begin by looking at the experimental science films of Jean Painlevé, as well as their deep ties to the Surrealist and Dadaist films of Jean Vigo, René Clair, *Luis Buñuel*, *Salvador Dalí*, and others. My contention will be that Painlevé's films in particular form the basis for a theory of visual media that propels scientific thought toward an outside that it is incapable of being resolved within a representational framework. In short, Painlevé's images provide a "shock" to scientific

thought, in Deleuze's vocabulary, and forces it to confront its outside qua aesthetic. This will provide a foundation for Chapter 4's discussion, which tries to cash out what an aesthetics beyond (or before) representation might mean philosophically and politically. I do so by drawing on Deleuze's reworking of Kant's two formulations of the aesthetic in the First and Third critiques. My hope is that these two chapters provide sufficiently interwoven archival and theoretical material to begin to formulate how (1) this aesthetics of visual media opens scientific epistemology up to a form of political resistance to representation; and how (2) this genealogy of nonrepresentation provides new coordinates for understanding the potentials of molecular animation, which have so far remained dormant.

3.2 Jean Painlevé: Scientist, Artist, Philosopher

Jean Painlevé's cinematic "science experiments," of which there are more than two hundred between 1927 and 1982, are almost as absent from film-history canons as they are from the annals of scientific imaging. In commenting on this relative absence, André Bazin writes that,

It is not certain, unfortunately, that this startling cinematic truth [that the cinema can be both artistic and scientific] can be widely accepted. It harbors too much potential scandal at a cost to current notions of art and science. This is perhaps why local audiences protested against and declared as sacrilege the jazz music that accompanies the little underwater dramas in Jean Painlevé's film *Freshwater Assassins* (Bazin 2000: 147).

For Bazin, Painlevé's films are anomalous as they are brilliant. They occupy a strange middle ground between science and art, and are largely unacceptable to histories of either one: too scientific to be art, and too artistic to be science. And yet to be able to traverse the space between science and art, between scientific documentation and artistic expression, is precisely what I will argue Painlevé demands of "scientific cinema."

Straddling these two worlds is evident enough any of his films. Take one of his more well-known experiments from 1965, *The Love Life of the Octopus*.



Figure 17: Taken from *The Love Life of the Octopus* (1965).

Mixing matter-of-fact commentary about the cephalopod—“Water inhaled through an opening on each side of its body is expelled through a tube”—with wry commentary about reproduction—“The male must insert the end of his special arm into the respiratory opening of the female. There is no recommended position to achieve this”—and countless other whimsical interludes and bits of scientific “seriousness” make the film, along with just about every other film Painlevé made, difficult, if not impossible, to classify.

But what, then, is this strange genre of film? Documentary? Research film? Avant-garde cinema? And who is the intended audience? Scientists? Artists? The general public? Or perhaps community that does not yet exist, a “people to come?”¹⁴³ Painlevé’s own biography offers some

¹⁴³ This alludes to Deleuze and Guattari’s remark in *What is Philosophy?* (and other places) concerning “the people to come” (1994: 110), but which “do not yet exist” (108). This is the foundation for their new image of the political that I try to cash out in Chapter 4.

assistance here, inasmuch we glimpse a man who is deeply indebted to both the life sciences and art practice, but who insisted on remaining stranger to each.

Born on November 2, 1902 in Paris, Jean Painlevé was the son of Paul Painleve, a prominent mathematician who also served as the French prime minister twice, and whose moderate-to-progressive politics were unpopular at the elite schools Jean attended. As Brigitte Berg has noted,¹⁴⁴ his father's politics made the young Jean an outcast at school— “my only friends were Jews and outcasts” Jean noted later in life—which led him to take

refuge at the Saint Michel theater, the first cinema on the Left Bank. There he and his nanny would watch the comedies of Mack Sennett, the fantasies of George Méliès, and the cartoons of Emile Cohl, as well as the popular serials *Le Masque aux dents blanches*, *Les Mystères de New York*, and *Fantômas*, which ‘obliged one to hold one’s breath till the following week’s conclusion’ (Berg 2000: 7).

Many of these early cinema-going experiences would stay with Painleve throughout his life, praising both Emile Cohl and Georges Méliès, for example, at the first public screening of *Blue Beard* in 1938. But given Paul Painlevé's prominent status as a mathematician and statesman, there was an unavoidable pressure to pursue mathematics in Jean's early life. Frustrated, however, with the rigidity of mathematical formalism, as well as the mystique surrounding mathematics at the prestigious Lycée Louis le Grand where he had studied, Painleve did not pursue his intended (or prescribed) path of studying mathematics at the Ecole Polytechnique where his father had once taught. Instead, he entered the Sorbonne to study medicine in 1921; but just two years later he would leave medicine for biology and zoology after a dispute with a medical professor.¹⁴⁵ Painleve scholars have noted that he was a gifted biologist, and that he could have had an illustrious scientific career, having coauthored a paper in 1923 on the color staining of glandular cells in

¹⁴⁴ See Brigitte Berg, “Contradictory Forces: Jean Painleve, 1902-1989” in *Science is Fiction*.

¹⁴⁵ As Berg tells it in her article, “Contradictory Forces: Jean Painleve, 1902-1989,” Painleve was interested in natural sciences from a very early age.

chironomid larvae, which was presented at the Académie des sciences, and made the following headlines: “Twenty-Year-Old Son of Statesman Paul Painlevé, Youngest Researcher Ever to Present a Paper to the Academy.” Even with such an early accomplishment, Painlevé found himself frustrated with the stifling intellectual space of academia (in Berg 2000: 12).

Thus, instead of seeking the company of other scientists, Painlevé sought friendship and inspiration from avant-garde artists in France, many of whom were deeply influenced by Surrealism. It is unclear how much influence his lifelong love affair with Geneviève Hamon — known as “Ginette,” the daughter of writer-anarchists, as well as Painlevé’s frequent collaborator—may have had on Painlevé’s interest in the French avant-garde. Nevertheless, Ginette’s family home in Brittany at Ty an Diaoul became a summer residence for Hamon and Painlevé where they hosted artists such as Pierre Prévert, Alexander Calder, and others. There, in the company of artists, Jean would work, discuss, and drink during the summer. Despite the many friendships with artists, and especially Surrealists, that Painlevé forged during these summers—including Pierre and Jacques Prévert and Painlevé’s own cousin, Pierre Naville, and others—he never officially joined any of the so-called Surrealist camps. (I think this is instructive, since, as I discuss below, his later films don’t sit comfortably in any of the “avant-garde” factions, including the many Surrealist ones.) That said, Painlevé did nonetheless publish the only issue of the review *Surréalisme*, along with Ivan Goll, Guillaume Apollinaire, René Crevel, and others (see Berg 2000).

And it is during this same time, roughly the mid-1920s, that ciné-clubs were emerging in France, and were playing a new kind of experimental short film that challenged the dominance of commercial cinema, including now classic avant-garde films, such as René Clair’s *Entr’acte*, Luis Buñuel and Salvador Dalí’s *Un Chien andalou*, and Fernand Léger’s *Ballet mécanique* (more on

these later). And it is at these clubs that Painleve would meet his great friend, Jean Vigo, who unfortunately died of tuberculosis in 1934 at the age of twenty-nine.

Despite Painlevé's growing fascination with the avant-garde and ciné-club culture, as well as his clear distaste for the rigidity of academic science, he nevertheless screened his first film, *Stickleback's Egg: From Fertilization to Hatching* (1927), for an audience of scientists at the prestigious Académie des sciences in 1928 (the same venue, incidentally, where Jean Comandon screened his film on syphilis almost two decades earlier). The film was not well received. Similar to the reaction Comandon received in 1910 (see Chapter 2), scientists were outraged at the film's "lack of scientific rigor," and one angry scientist proclaimed that, "Cinema is not to be taken seriously!" According to Berg, this skepticism didn't discourage Painleve, but only reaffirmed for him the importance of "science films," and the need to create venues outside of academic science for screening these important works. To answer this call to arms, Painleve, along with Michel Servanne, cofounded the "Association for Photographic and Cinematic Documentation in the Sciences" in 1930.

But if Painlevé's work was met by serious skepticism from the scientific community, it was fully embraced by the French avant-garde. For example, Ferdinand Léger, Man Ray, Marc Chagall, and Georges Bataille all praised Painlevé's *Caprella and Pantopoda* (1930); Chagall even called it "genuine art, without fuss,"¹⁴⁶ and Man Ray used footage of starfish from the film for his *L'Etoile de mer* (1928). The critical success of this film was also amidst an incredibly productive time for Painleve, who, between 1928 and 1930, made eight films on marine wildlife for popular audiences: *La Pieuvre/The Octopus* (1928), *Le Bernard l'ermite/The Hermit Crap* (1929), *La Daphnie/The Daphnia* (1929), *Hyas et Stenorinques, crustaces marins/Haya and Stenorhynchus*,

¹⁴⁶ Marc Chagall was quoted in the newspaper *L'Intransigeant* (23 December 1930).

Marine Crustaceans (1929), *Les Oursins/Sea Urchins* (1929), *Caprelles et Pantopodes/ Caprella and Pantopoda* (1930), *Crabes/Crabs* (1930), and *Crevettes/Shrimp* (1930). Painlevé would remain an active filmmaker and inventor,¹⁴⁷ as well as film and political activist until the end of his life— his final film, *Pigeons of the Square*, was completed in 1982—and would continue to collaborate with artistic luminaries such as Joris Ivens, Georges Franju, Luis Buñuel, Antoine Artaud, among many others.¹⁴⁸

If one were then forced to classify Painlevé’s films, or in any case, assess their audience and spheres of influence, they seem to sit most comfortably among other early twenty-century avant-garde films, despite Painlevé never officially endorsing Surrealism, or any other avant-garde movements. Furthermore, Painlevé harshly criticized the tradition of “scientific cinema,” calling their filmmakers “enemies of the cinema” (Painlevé 2000: 161); and he even suggested that such films should have never been made (162). By all accounts, it seems perfectly reasonable to classify Painlevé’s work as “art cinema,” even when its subject matter is similar to the scientific-research films of his day. There is something elusive, dreamlike, and even “bohemian” in Painlevé’s underwater film adventures, explains the writer Léo Sauvage, which “[challenge] the mummified science of the Academy in the most insolent way” (in McDougall 2000: xv). This is perhaps why it seemed so natural, and even obvious, for Henri Langlois to substitute the term “avant-garde” for “scientific” in the program notes to a screening of Painlevé’s films at festival in Basel, Switzerland in 1954.¹⁴⁹

And yet, dividing “artistic” and “scientific” cinema in this way is precisely the kind of disciplinary division that would have troubled Painlevé. Despite associating with the avant-garde,

¹⁴⁷ See Berg 2000.

¹⁴⁸ See *ibid.*

¹⁴⁹ See *ibid.*

and even experimenting with many of their methods (many of which I discuss below), Painleve remained a committed scientist whose love affair with laboratory work never faltered. So for example, much of the filming of *The Seahorse* (1933) took place in a basement laboratory in Paris, which housed large seawater aquariums. But so that Painleve did not miss one of the seahorses give birth due to his own fatigue (days of observation without sleep), he invented a visor that emitted an electric shock if he nodded off and his camera bobbed. The invention was what allowed Painlevé to film the event. Painleve remained in this instance, and in countless others throughout his career, unwavering in his commitment to observing natural phenomena under laboratory conditions.

What, then, is the difference between Painlevé and any other biologist? What infuriated Painlevé about other so-called “scientific films” is that they were only used to summarize other research, research already completed and done by other means. In other words, the apparatus is used to give visual representation to what is already known, instead of being used to explore the unknown. Thus, film is most often an afterthought to rather than a unique medium for research.

Painleve insists that,

nothing should be put on film that can be demonstrated either directly, on a blackboard, through a slide projector, with an epidiascope, etc. Currently, most of the films used for educational purposes have been made by teachers for teachers with the students forgotten along the way. At best, they are a rehashing for an informed audience, a summing up of one’s studies. But such is the current fashion—and a profitable one (many hope so, at least). Hence, a profusion of perfectly useless films as far as teaching is concerned (Painlevé 2000: 162).

For Painlevé, as I discuss in more detail below, film provides its own technical means for doing research. Just as research performed through a microscope needs to be aware of its own mediation—something nineteenth-century microscopists such as C.R. Goring were all too aware

of, for example¹⁵⁰—so too Painleve thought that the camera provided its own singular means for investigating the natural world, which itself required investigation. Perhaps this is what Painleve appreciated so much about the avant-garde: namely, its commitment to investigating its own research media. Paint, clay, celluloid, canvas, text— the potentials of each are investigated just as much as the subjects they are supposed to “represent”: the crippling effects of modernity, for instance (see below). The two are inseparable for Painleve, which leads him to champion a much earlier example of science cinema than the one currently in fashion: “It would never have occurred to the pioneers of cinema [Marey, Muybridge, the Lumieres] to dissociate research on film from research by means of film” (162). In other words, the cinema offers a very specific form of mediation that is as much a part of the research as the events unfolding in front of the camera. Painleve is not forsaking science for the cinema, but he is being an incredibly careful scientist— attending to all levels of mediation: the specimen as well as the methods and materials of its observation.

3.3 Research Methods

What, then, are the very specific forms of research that the cinema makes possible? Put another way, what is it that impels Painlevé to record the biological world from behind the lens of a movie camera, instead of using some other visual technology? As we saw in Chapter 2, Ries, Comandon, and Carrel all believed that the cinema, as opposed to photography, captured the *time* of embryonic development. The perception of time is thus what microcinematography affords scientific research. And yet while Painlevé clarifies what the cinema *shouldn't* make possible, he is much less clear about what it *does* make possible. So for example, he is careful to point out in his “Ten

¹⁵⁰ See Lisa Cartwright, *Screening the Body: Tracing Medicine's Visual Culture*.

Commandments” that film should not “influence the audience by unfair means” (Commandment 3); instead, it ought to “seek reality without aestheticism or ideological apparatus” (Commandment 4), and thus “abandon every special effect that is not justified” (Commandment 5), which means, for him, abstaining from the use of “clever editing unless it illustrates your good intentions” (Commandment 7). And those “good intentions” circle back, one could only assume, to Commandment 4: the commitment to filming “reality” free of “ideology or aestheticism” (Painlevé 2000: 159). In fact, in his essay “Scientific Film,” Painleve goes so far as to claim that films that “distance” us from the experience of “reality” should never have been made: “not every subject is suitable for a film,” he explains, “anything that distances one from the direct experience of something is mere counterfeit and should be avoided” (2000: 162).

But what, precisely, Painlevé means when he claims that the cinema ought to let us “experience reality” instead of cloaking it in “ideology” and “aestheticism” is not spelled out in a straightforward way. Furthermore, nowhere does Painleve offer a “theory of the cinema” in the way that, say, Bazin, Kracauer, or Eisenstein do. Where the latter carefully articulate theories of the cinema, Painleve, by contrast, drops clues and hints throughout his writings, interviews, and films that we, the critics and theorists, may or may not be able to piece together. Rather than see this as weakness of his work, or as a failure to achieve coherence, I would argue that it is a symptom of the fact that Painleve treats the cinema as every bit a part of his scientific investigation as the natural world it is recording. The cinema and the natural world remain open questions for him. Perhaps this is how Painleve keeps the spirit of Muybridge, Marey, and the Lumieres alive in his own work.

What we do know from Painlevé’s writings, however, is that scientific cinema worthy of being made strives to be free of all those distortions — introduced by “clever editing,” etc.— that

obscure “reality” with “ideology” and “aestheticism.” I can only surmise that these comments reference Painlevé’s deep skepticism over human intervention in scientific filmmaking (which betrays a certain commitment to or affinity for Surrealist automatism¹⁵¹), which is confirmed by his worry that scientific cinema is constantly reconciling with the twin dangers of anthropomorphism and anthropocentrism. In “La Beaute du film documentaire, le film biologique” (“The Beauty of Documentary Film: The Biological Film”), Painlevé explains that anthropomorphism and anthropocentrism are the “two blinders” (*oeilleres*), which largely determine what’s visible for the wildlife filmmaker: “one would like to find the emotional factor and control its variations even though, constantly swinging between anthropomorphism and anthropocentrism, we are incapable of understanding an animal that does not remain within the field determined by these two blinders” (Painlevé 1930: 6).

And crucially for Painleve, one of the clearest catalysts for these twin poles of human prejudice in science film is spoken language. Needless to say that he did not welcome the arrival of sound film in France with open arms.¹⁵² In fact, Painleve was openly critical of how using prerecorded voices would “domesticate” his wildlife films. Critical of the mounting demand for “talkies” by the entertainment industry, he even proclaimed that the voice was an “irritant” and that it was “in contradiction with the photographic image” (Painlevé 1929: 3). For Painlevé, the voice is “functional” and “by definition... made to be understood... it is thus incompatible with all the plastic, deformable, and imaginative visuals that represent photographic art” (18). Spoken language therefore tames pure “optical neutrality,” it domesticates it, and makes it then capable of human signification. In other words, the voice allows the image to represent something. The visual field is thus limited by the voice; it makes it possible for humans to find their bearing, to

¹⁵¹ See Malcolm Turvey, *The Filming of Modern Life: European Avant-Garde Film of the 1920s*, Chapter 4.

¹⁵² See Leo Cahill, “Anthropomorphism and its Vicissitudes: Reflections on *Homme-sick* Cinema.”

anthropomorphize. The voice has a primarily normative function for Painlevé.

This seems to explain why Painlevé announces in “Les Films Biologique” that he is an advocate of “pure cinema,” by which he means “silent film”— although he admits that such “purity” is more of a utopian ideal than actuality (1929: 18).¹⁵³ What Painlevé celebrates about the image uncorrupted by the voice is the pure “indifference” of the “mechanical eye,” the fact that meanings proliferate and ramify in these pure optical situations without being fixed and geared toward human comprehension.¹⁵⁴ The “cine-eye” deterritorializes the image from human meanings, or the sensory-motor schema, as Deleuze might say. But the sound film, or at least as it was promulgated by the entertainment industry in the first half of the twentieth century, re-anchored the image in functionality, and was therefore an enemy of the cinema.¹⁵⁵

But anyone familiar with Painlevé’s films will immediately object that they are full of narrations, and other explicit instances of anthropomorphism. In fact, one of the most enjoyable aspects of his cinema is the humorous narration: “Shrimping is the most beautiful and most enviable of sports.” Add to this, Painlevé is renowned for making visual parallels between wildlife and forms of human activity through montage. For example, in *The Vampire*, Painlevé uses clips from Murnau’s *Nosferatu* (1922) and then explicitly demonizes the vampire bat’s outstretched wings by comparing it to the heil-Hitler salute.

¹⁵³ This resonates with conversations in avant-garde cinema regarding “Cinema Pur,” by filmmakers such as René Clair, Man Ray, Dziga Vertov, and others. See Malcolm Turvey, *The Filming of Modern Life*.

¹⁵⁴ The notion of a “pure optical situation” is deeply important to Deleuze in his cinema books.

¹⁵⁵ See Leo Cahill, “Anthropomorphism and its Vicissitudes: Reflections on *Homme-sick* Cinema.”



Figures 18&19: Taken from *The Vampire* (1945).

Or in the *Love Life of the Octopus*, the narrator informs us that the folds on the octopus' eyes function like eyelids, which leaves us recognizing the “head-footed” mollusk's sleepy look.

And in the *Seahorse* (1934), the narrator informs us that the erect posture of the seahorse is unique among the aquatic vertebrates, and that it displays a “slightly affected air of dignity”; the camera then delights in showing two seahorses linking their tails as if they were holding hands.

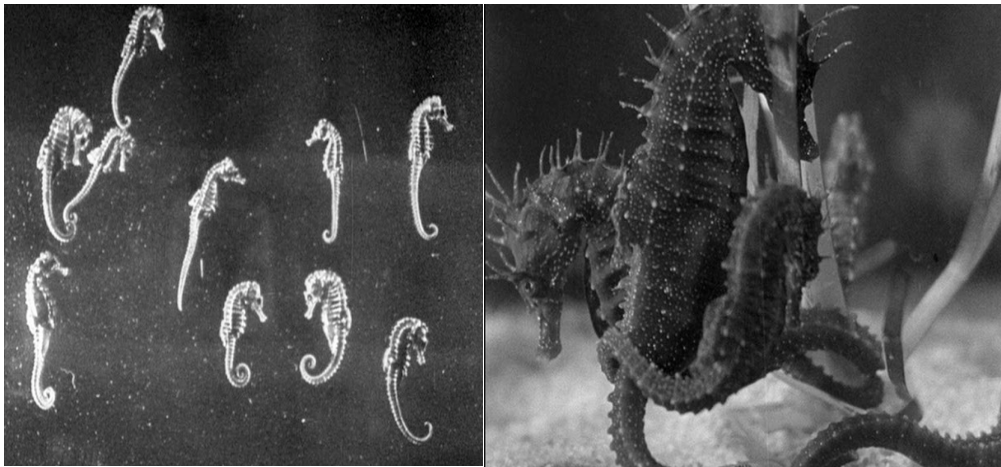

Figures 20 & 21: Taken from the *Seahorse* (1934).

Upon closer inspection, Painlevé's films seem far indeed from continuing the tradition of “silent

cinema,” and seem to showcase many instances of explicit anthropomorphism.

So does Painlevé simply contradict himself? Not exactly. It should be noted that Painlevé struggled with the question of narration, and seven out of the eight documentaries released between 1928 and 1930 were originally released as silent prints, and were then later sonorised. Thus, his reluctance to sonorise, one can only surmise, did not stem from a rejection of the voice *tout court*. As James Leo Cahill eloquently puts it, Painlevé saw only those benefits of vocal expression that his one-time collaborator, Antonin Artaud, championed: namely, the voice freed from its functional dimensions and imbued with the “schizoid” potentials, which Gilles Deleuze celebrated decades later. “In the absence of an Artaudian language,” explains Cahill, “endowed with animal gaiety, capable of producing physical shocks equal to that of the image, spoken language primarily had the normative effect of fixing image in meaning” (Cahill 2013: 79). So although Painlevé decided to add narration to many of his films, this choice may not simply be a case of inconsistency or compromise. It’s worth wondering, then, whether sonorisation is achieved in many of these instances, such that it produces an indifference or neutrality that is equal to that of the image.

Even if this is the case, which is to say, that the voice is deterritorialized from meaning in some instances, the problem of anthropomorphism does not disappear—in both in its sonorous and visual forms. In fact, the persistence of anthropomorphism in Painlevé’s films is something that nearly all of his commentators point out (See Berg 2000; Rugoff 2000; Cahill 2013). Add to this that in 1929 Painlevé remarks that “one cannot entirely cure oneself of” anthropomorphism, as if the tendency to see the world in our image were a sickness that we must live with (Painlevé 1929: 17). And then, many decades later Painlevé complicates his relation to anthropomorphism even further when he exclaims that, “We commit anthropomorphism. We have the right to commit anthropomorphism. If not we would be incapable of appreciating any element around us” (in Cahill

2013: 81-82).

At first Painleve seems to critique anthropomorphism, even maligning vocal expression because it fastens the image to human meaning. And then later he seems to say that it is our *responsibility* to anthropomorphize. How do we make sense of this? My suggestion here is that rather than treat these as contradictory statements, as if Painlevé merely goes back on his utopian ideals, that we regard them as expressing the much larger “problematic” of anthropomorphism. And by problematic I don’t mean to suggest that anthropocentrism is problem that needs a solution, but that anthropocentrism is a problem in the way that Deleuze spells it out in *Difference and Repetition*: it is a horizon of (virtual) tensions that are generative of (actual) solutions that never exhaust the problem, but only transform it.¹⁵⁶ Viewed in this way, anthropomorphism is not something that ever goes away—as if there was a final (re)solution to it—which is what Painleve realized as early as 1929; rather, without a way out, or a final solution to anthropomorphism, critical emphasis now falls on *how* we anthropomorphize, *how* we see ourselves in other species, how we respond to this problem. Anthropomorphism in science film is thus ethico-political (something I return to in Chapter 4).

To pick up on our discussion from the previous chapter, what Painleve realizes is that recognizing, and thus representing, nonhuman life in terms of human values is inescapable, or is in any case, a “fact” of human cognition that allows us to make sense of and engage with our environment. If it were not for these abstractions, “we would be incapable of appreciating any element around us.” In this regard, Painleve is not launching a “critique of representation” in the sense that critical and cultural theorists have become accustomed to since Kant: namely, the elimination of such crippling abstractions in science in order to uncover something more

¹⁵⁶ See Deleuze, *Difference and Repetition*, Chapter 3.

primordial or fundamental. Painlevé is far more subtle than this: he is not interested in doing away with representations *tout court*, but in transforming how we value them, how we regard our anthropomorphisms. Do they offer the last word on a species? Do they provide final judgments? Or are they only highly localized ways of interacting with one's environment, which may appear totally nonsensical from another perspective?

From this vantage, Painlevé has important, if surprising, resonances with another early twentieth-century thinker: Alfred North Whitehead. For Whitehead, scientific representations are not in need of “Critique”—as if philosophy were supposed to rid the world of falsifying abstractions—but of re-valuation: we need to “re-engineer” our modes of value, Whitehead explains in *Science and the Modern World*, so that we do not endow abstractions with more value than they deserve (see Whitehead 1967: 59).¹⁵⁷ And just as Whitehead uses the materials he has, namely, language (see Whitehead 1968: 49-50), so too, Painlevé must draw on his materials, namely the visual and sonic materials of the cinema, in order to “re-engineer” the way human's experience their anthropomorphisms, their tendency to represent other species in terms of human values.

My hypothesis is that what Painlevé achieves in his films is not so much a critique of anthropomorphism as much as its a reframing of it: he expresses the fact that anthropocentrism is contingent upon human modes of engagement with the world, and not upon a necessity outside of these modes. Much as Whitehead tries to resituate our representations in terms of a much larger environment, similarly, Painlevé exposes the relative importance of our representations—that they are dependent upon human modes of value. Without such a reframing, the risk is that anthropomorphism collapses into *anthropocentrism*. I believe this is what Painlevé meant when

¹⁵⁷ See my co-written introduction to *The Lure of Whitehead* (2014) for a sustained analysis of Whitehead's understanding of the re-evaluation of abstractions, as well as his relation to post-Kantian Critical philosophy.

he wrote that the human understanding of the animal world is “constantly swinging between anthropomorphism and anthropocentrism.”

Resituating Painlevé’s work in this way permits a fresh take on all those so-called troubling instances of anthropomorphism in his films. What we can now see is that those moments of anthropomorphic identification rarely, if ever, go unchecked by images or narrations that do not also unsettle our confidence in them. Painlevé delights in this kind of serious play. For example, in the sonorised version of fourteen-minute film, *The Hermit Crab* (1931), the commentary tells us that the hermit crab seeks shelter in shells that have been “abandoned by their landlords.” Immediately, viewers are drawn into an anthropomorphized understanding of the underwater creature: they too think of shelter in terms of tenants, landlords, and possible evictions. Painlevé also amuses in exploring the latest hermit-crab fashions, as well as the kinds of “sport” they play.

But complementing these moments of anthropomorphic identification are moments of extreme disorientation. Early in the film, the narrator tells us that, “with some magnification, one can make a monster out of these charming little animal”; and then, immediately afterward, Painlevé cuts to an extreme close-up of the same “charming little animal,” but now it is unrecognizable, even hideous. From one perspective, the crab is a receptacle for all of our anthropomorphic identifications, and from another, it defies all of them. Where Painlevé invites us to welcome the hermit crab into our sphere of human recognition, even encouraging us to see resemblances between its search for a home and ours, he then immediately undermines this confidence with images of a creature that could not possibly be at home with us. The hermit crab is *unheimlich*.¹⁵⁸ The joy that accompanies the anthropomorphic identification with animals, similar to the joy we may experience when identifying anthropomorphic traits in Disney cartoon animals, is unsettled

¹⁵⁸ See Ralph Rugoff, “Fluid Mechanics,” for a treatment of the uncanny in Painlevé.

by shots that make identification impossible, and even, in some instances, horrific.

Similarly, our recognition of the sleepy mollusk in *The Love Life of the Octopus* (Figure 22) is undermined by disturbing shots of its sex life: sex with sixteen tentacles; or by close-ups of a suction cup on an individual tentacle, which makes such a recognizable feature of the octopus' physiology nearly unidentifiable.



Figure 22: Taken from *The Love Life of the Octopus* (1967).

Or again, any confidence that we may have had in our identification with the vampire bat in *The Vampire* is unsettled by repeated shots of its hideous snout (Figure 21), as well as the explicit links forged among the bat, who preys on the helpless guinea pig, the life-sucking powers of Nosferatu, and the inhuman politics of Nazism. The bat resists identification, or at least it *ought* to.



Figure 26: Taken from *The Vampire* (1945)

What these instances, along with countless others, demonstrate is that Painlevé's commitment to "Cinema Pur" is complicated: montage, non-diegetic sound, extreme close-ups, and other editing techniques are all used to deterritorialize the image from its "domestication" in human meaning. This is not to say that Painlevé now endorses the "clever editing," "trickery," and the substitution of words for images that he once maligned (see Painlevé 2000: 159); rather, I think an argument can be made that his editing work promotes the "good intentions" he demands of pure documentary film (see *ibid.*): in short, they are used to express how our confidence in the natural world can be dislodged with a slight shift in perspective. A "cuddly critter" from one angle, can also be a hideous beast from another. Any certainty we may have enjoyed from representation is a symptom of a more deeply rooted anthropocentrism. In this way, Painlevé marshals anthropomorphism to critique anthropocentrism.

Painlevé's camera thus delights in exposing how the entire range of human identification, from our austere molecular-perceptions to our aesthetic amusements, perfectly expressed by the shots of the erect seahorse in the *Seahorse* (see Figures 23 and 24), are uprooted through contrasts

that express life's own resistance to representation: "there is an infinite field of magnificent and continual joys," explains Painlevé, "that prevents us from completely elucidating the mystery or the miracle" of life.¹⁵⁹

In other moments, however, Painlevé is less concerned with illustrating life's resistance to representation through contrasts, and more interested in contemplating the impossibility of establishing any reference point at all. Instead of flooding the visual field with irreconcilable oppositions (the "cuddly critter" and the hideous monster, for instance), he contemplates the helplessness that human cognition experiences before the vastness of "life itself." In these instances, life shows itself to be wiggling, jerking, floating, oozing, or pulsing, without a cause, or relation to any noticeable context. Such radically deterritorialized movement makes classification impossible. It's not that movement is merely inhuman or strange, irreconcilable with previous visual representations, it's that movement is altogether indeterminate, without a reference. A scene from *Acera or The Witches' Dance* (1972) demonstrates this vividly: set to a score by Pierre Jensen, mollusks weightlessly rise and fall in an underwater choreography (Figure 27). And yet, the viewer is left with very little to secure this visual reference. The mollusks could just as easily be flying mushrooms. Hence, are these magnificent creatures underwater or out of water? Flying or swimming? Plant or animal? Organic or inorganic? None of these questions are answered definitively. Painleve lures the viewer into marveling at images *emptied* of concrete reference; and left in the place where representation once had a firm hold, is a suspension of judgment and determinacy—pure inaction.

¹⁵⁹ I would even argue that Painleve perversely express Sergei Eisenstein's observation that what makes Disney cartoons ingenious is not their continuity or identity over time, but their "plasmaticity," or ability to mutate and transform. It's just that "mutation" is deeply unpredictable for Painleve, and may even be repulsive See *Eisenstein on Disney*, edited by Jay Leyda.

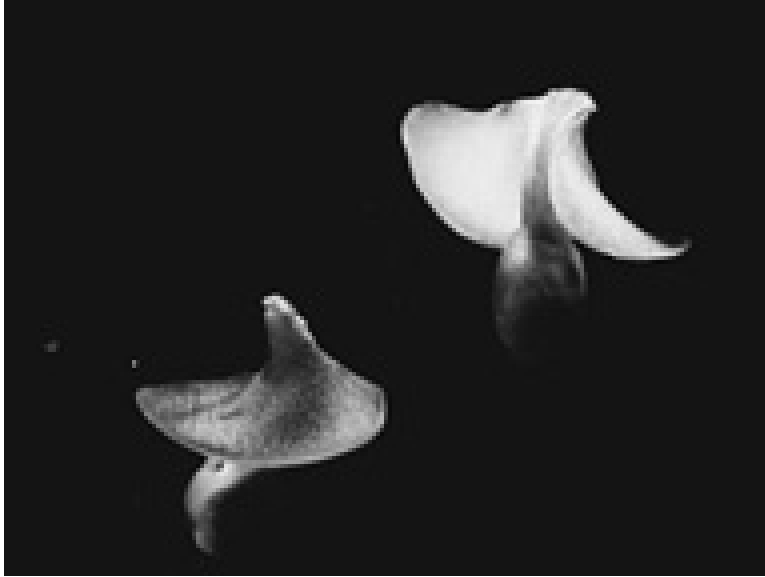

Figure 23: Taken from *Acera or The Witches' Dance* (1972).

In moments such as these, Painlevé's spiritualism also becomes pronounced.¹⁶⁰ Not only do the mollusks become weightless but so do the viewer's perceptual-cognitive systems: the weight of recognition and certainty is lifted, and the potential for Life's reference is carried to infinity. The weightlessness or spirituality (in a strictly secular sense) of Life infuses our perceptual-cognitive system so that it is no longer grounded in a concrete reference, or in the "depths of bodies" as Deleuze would say, but in infinite potentials for convergence and divergence. Life is fully abstract in these moments: abstracted from any form of life in particular but immanent to all of them in general.¹⁶¹

¹⁶⁰ Painlevé as a "spiritual" filmmaker has yet, at least to my knowledge, been explored. Questions of the "uncanny" and the "horrific" have been noted in the critical literature, but without mention of the "spiritual" side of Painlevé's nature cinema. It seems to me that the connection among spirituality, the horrific, and even the occult would be worth exploring in more detail, especially in relation to Deleuze's spiritual occultism explored in Joshua Ramey's work, *The Hermetic Deleuze: Philosophy and Spiritual Ordeal*.

¹⁶¹ See Deleuze, "Immanence: A Life," and *The Logic of Sense*.

3.4 The Surreal, the Fragmented, and the Ideal

Before taking up the theoretical consequences of Painlevé's "image of Life" in earnest in Chapter 4, it's worth investigating the connections that emerge between his films and the European avant-garde. This comparison is important for at least two reasons. The first is that although Painlevé's loose associations to Surrealism have been noted in the secondary literature, and were briefly mentioned above, there are also good reasons to resist this label: mainly because his films freely experiment with many avant-gardist principles and techniques (Cubism, Dada, etc.) without dogmatically endorsing any of them. And the second, and perhaps most pressing, reason to explore this connection is to show how it is nevertheless an association that firmly locates Painlevé's cinema within a history of political aesthetics.

Let us look more closely at Painlevé's connection to Surrealism. As noted above, Surrealist filmmakers often adopted the methods of "automatism" endorsed by Breton.¹⁶² In the hands of Salvador Dalí, who co-directed *Un chien Andalú* (1929) with Luis Buñuel, the cinema, much like the photograph, embodies the principle of automatism: it fully mechanizes the recording of reality, and, in principle, erases all traces of artistic imaginings that could obscure nature in its extraordinary and surreal mystery.¹⁶³ For Dalí, the external world is far more complex and mysterious than anything an artist could ever imagine. Hence, "subjectivity" distorts the truly baffling "objective" world, which is why Surrealist cinema is "anti-art" for Dalí. In a text written about *Un chien Andalú*, Dalí proclaims that there are

facts, simple facts independent of convention; there are hideous crimes; there are irrational and unqualifiable acts of violence which with their comforting and exemplary brilliance shed light upon the distressing moral panorama. There is the anteater, there is, quite simply,

¹⁶² See *André Breton: The Power of Language*, edited by Ramona Fotiade, especially Roger Cardinal's essay, "André Breton and the Automatic Message."

¹⁶³ This is an interesting contrast with what was explored in the previous chapter. In the sciences, the cinema was dangerous.

the forest bear, there is, etc.” (Dalí 1998: 109).¹⁶⁴

For Surrealists such as Breton Dalí, and Buñuel,¹⁶⁵ the surreal, which is to say, the irrational and marvelous, is fully contained within the real, and exemplified by oddities in nature such as the anteater. And there are recording instruments, such as the cinematograph, which are particularly well attuned to capturing this brute surreality without artistic invention. This is what allowed Dalí to claim that *Un chien Andalou* is “about simple notation, the observation of facts” (Dalí 1998: 108), and that it was “created without any aesthetic intention whatsoever” (ibid.).



Figure 24: Taken from *Un Chien Andalou* (1929) via web search.

¹⁶⁴ Also see Roger Rothman, *Tiny Surrealism: Salvador Dalí and the Aesthetics of the Small*, for a careful discussion of Dalí's surrealist aesthetics.

¹⁶⁵ See Haim Finkelstein, *Salvador Dalí's Art and Writing, 1927-1942: The Metamorphosis of Narcissus*, for a careful study of how Dalí and Brunel differ in many respects. In particular, Brunel was far less “anti-art” as Dalí, especially with reference to the cinema.

Painlevé is sympathetic to many of the same principles. Recall that Painlevé believed that the “machinic eye” of the camera dislodges perception from human intention and reference, which is re-stabilized by the functional character of the voice. Thus, a kind of “automatism” is certainly detectable in Painlevé’s work. At the same time, however, Painlevé is skeptical that we could ever root out human meaning and intention altogether in the cinema: recall that without it, “we would be incapable of appreciating any element around us.” Even with the “mechanical eye” of the cinema, anthropomorphism is unavoidable: “one cannot entirely cure oneself of” anthropomorphism, writes Painlevé in 1929. So although he may indeed endorse the notion that “cine-eye” deterritorializes perception, this deterritorialization is never absolute in the way that Dalí seems to suggest. Rather, deterritorialization and reterritorialization go together for Painlevé, which is why emphasis falls squarely on investigating *how* humans reterritorialize, or anthropomorphize, instead of seeking ways to get rid of anthropomorphization altogether—also an idealization. The question for Painlevé is therefore: How can we ensure that a given anthropomorphism expresses its own potential for uprooting, or deterritorialization, in order to guarantee that it doesn’t become anthropocentric? In what ways can anthropomorphism be mobilized to critique anthropocentrism?

Thus, instances of human expression and artistic invention are not ipso facto problematic for Painlevé in the way that they are for other Surrealists. Where Dalí (and Buñuel) berates Fritz Lang’s *Metropolis* (1927), calling it “artistic putrefaction” (Dali 1998: 25), Painlevé, by contrast, makes use of expressionist images in his own films (e.g., Murnau’s *Nosferatu* in *The Vampire*), and praises early examples of animation by Émile Cohl and Georges Méliès (see Painlevé 2000). Furthermore, Bazin writes that “His *Vampire*, for example, is at once a zoological document and the fulfillment of the great sanguinary mythology illustrated by Murnau in *Nosferatu*” (Bazin 2000:

147). Painlevé's work is both an "objective" document from the surrealist and zoological perspective (hence, Painlevé's own essay "Neo-Zoological Drama" published in *Surrealisme* in 1924) and an expressionist masterpiece; it exemplifies these contrasts, these fragmentations, in the service of dislodging our anthropocentric representations of "nature."

It is precisely these contrasts that resonate with other avant-gardist principles; indeed, they are principles that are often at odds with Surrealist ones. For example, the painter Fernand Léger, who co-directed *Ballet mécanique* (1924), along with American filmmaker Dudley Murphy, was strongly influenced by Abel Gance's film *La roue* (1922), proclaiming that Gance had "elevated the art of film to the plane of the plastic arts" (Léger 1973: 21; see Turvey 2011). Of particular interest to Léger was that fact Gance had not reduced cinema to other narrative arts, particularly the theatre, and that he had done this through extensive editing and close-ups, which illuminated the plastic features of the object—that is, its moldularity and reconstructibility through fragmentation and contrast. Léger believed that this emphasis on fragmentation and contrast was as compelling as any narrative. Gance's film was an incredibly important influence on Léger's work on *Ballet mécanique* between 1923 and 1924, a film which also makes extensive use of editing techniques—prisms, neutral backgrounds, aperture— and close-ups in order to isolate its subject matter from its everyday environment, and expose its plastic features, its combinations and permutations, its endless potential for fragmentation and recombination.¹⁶⁶

¹⁶⁶ See Malcolm Turvey, *The Filming of Modern Life: European Avant-Garde Film of the 1920s*, Chapter 2.



Figure 25: Taken from Fernand Léger and Dudley Murphy, *Ballet mécanique* (1924).

As Mathew Turvey notes in *The Filming of Modern Life*, the film assaults the viewer “with a bewildering array of often rapidly edited close-ups that force us to focus on the plastic properties of machines, machine-like entities, and a host of other objects” (Turvey 2011: 56). For example, section 4 (out of 7) of the film, pays particular attention to the similarities between machine and human components: the repetition of human movement, intensified by repeated jump cuts, is compared in the next shot to the movement of pistons. Objects can be taken apart, fragmented, and recombined; there is no “natural” way such components go together. Human movement is machine movement, and vice versa.

Such disorienting fragmentation has prompted film scholars such Turvey and Standish Lawder to revisit Léger’s paintings from the previous decade to interpret the film.¹⁶⁷ Lawder, for example, argues that in the 1910s Leger had developed a “cubist style,” which also drew on the

¹⁶⁷ See Lawder *The Cubist Cinema*.

“perceptual realism” of his day, in order to depict how the onslaught of industrialization and urbanization had fundamentally changed perceptual experience: it was no longer smooth and orderly but fragmented, disorderly, and even violent. It is the sensation of speed and fragmentation that he wished to give form to in paintings like *The City* in 1919; this is a painting that is particularly well attuned to the fragmented rhythms of urban life in the early twentieth century.



Figure 26: Fernand Léger. Oil on Canvas, 1919.

Lawder argues that *Ballet mécanique* wishes to impart an analogous perceptual experience on the viewer:

Contrast is the life-blood and the binding force of *Ballet mécanique*. The film is composed not from separate shots which link to each other as in most films, but from disparate ones which clash and collide... He sought to create in film the same discontinuous, fragmented, kaleidoscopic world that his paintings [describe]... (Lawder 1975: 167).

Supporting this thesis, Lawder points out that in unpublished notes for the first part of the film, Léger observes that it showcases the “constant opposition of violent contrasts” (121).

Right away we should notice similarities between Léger's and Painlevé's work. Though their subject matters are ostensibly different, and indeed so are their fields of expertise and spheres of influence, their commitment to harnessing the unique features of the cinema ("Cinema Pur") to expose the limitations of our fixed representations resonate deeply; and indeed, so does their mutual commitment to using extreme close-ups and a variety of editing techniques to dislodge objects from their everyday contexts and familiar meanings. Where human faces and movements are fragmented and brought into close proximity with machines and industrial artifacts in Léger, hermit crabs, mollusks, octopi, bats, guinea pigs, and sea horses are all are fragmented, transformed, and recombined in Painlevé. In this way, I'm tempted to suggest that Painlevé's science films elevate the cinema to a "plastic art": life gains a "plastic quality" from behind the lens of Painlevé's camera. And when such plastic features are visually expressed, the effects are very often violent and even horrific.¹⁶⁸

And, yet, these effects should not distract us from other crucial instances in Painlevé's work that assault the viewer far less than they provoke the suspension of all action. As we saw in *Acera or The Witches' Dance*, for instance, the mollusks' underwater choreography suspends the viewer's judgment, and demonstrates the pure indeterminacy of form, as all series converge and diverge on it at once. This kind of non-figurative abstraction is far less resonant with Léger's cubist cinema (whose abstract films use representational imagery) than it is with Hans Richter's abstract animations in the 1920s, which seek to abstract from differences in form in order to find deeper patterns of resonance.

Like Léger, Richter was trained as a painter who came under the influence of the Dadist movement in Zurich in late 1910s.¹⁶⁹ More than anything, what appealed to Richter about Dada

¹⁶⁸ More work needs to be done on the connection between avant-garde plastics and inorganic life in Deleuze.

¹⁶⁹ See Hans Richter, *Dada: Art and Anti-Art*, for his own account of Dada's significance.

was its critique of modern, industrial rationality: it was the principle cause of suffering in the contemporary world, and it found its principle expression in the First World War. In place of “modern rationality,” Dada promoted the “absolute freedom from preconceptions” (Richter 1997: 34). However, by 1917 Richter grew frustrated with his own methods of “spontaneous painting,” and he sought to find other ways to express “structured” forms of abstraction that did not simply replace reason with unreason (*pace* Dada), but found a “harmonious” relation between the two. And it is during this period, from late 1917 through the 1920s, that Richter would make his well-known *Rhythm* films, along with Viking Eggeling, and become involved with Dutch avant-garde movement, De Stijl.

Thus, when it came to diagnosing the problems of modern life, Richter was less interested in replacing “reason” with “unreason,” as many other Dadists were (e.g., the nihilism of Picabia and Tzara that Richter critiqued¹⁷⁰), and more interested in tempering reason, which is to say, restoring a balance between reason and unreason, or the unconscious.¹⁷¹ Similar to Painleve, the goal was not simply to rid human thought of rationality but to restore it to its proper place. Again, it is with this in mind that Richter made his *Rhythm* films.

¹⁷⁰ See Turvey, *The Filming of Modern Life: European Avant-Garde Film of the 1920s*, Chapter 1; and Richter, *Dada: Art and Anti-Art*, 60.

¹⁷¹ *Dada: Art and Anti-Art*, 58-59.

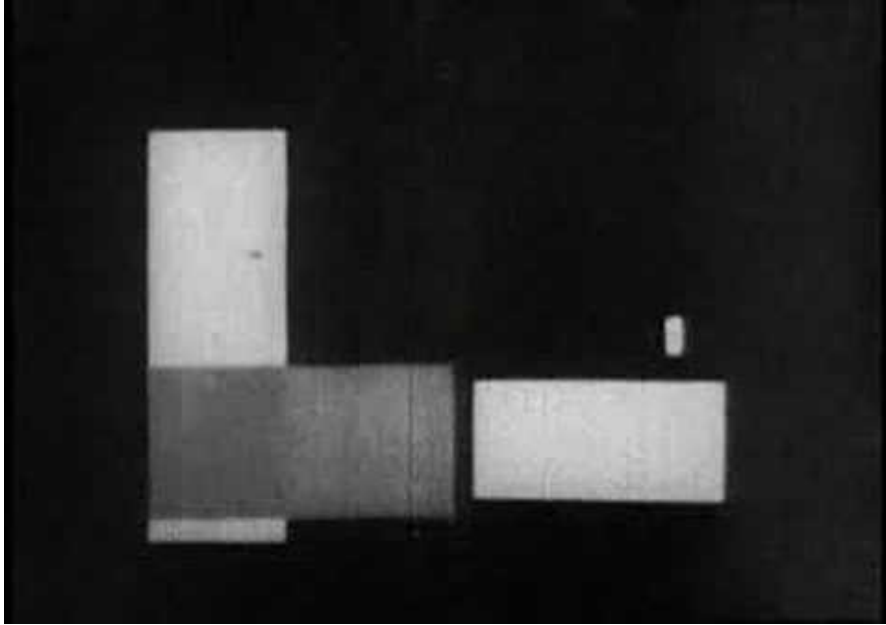

Figure 27: Taken from *Rhythm 21* (1921).

For Richter, one of the principle goals of *Rhythm 21* (1921) was to establish a careful balance between difference and similarity. So for example, the film opens with contrasts between the horizontal and vertical movements of figures, carefully matched with similarities among the color, shape, and speed of the figures, which establishes a relationship of interdependency over successive shots.¹⁷² The deeper balance of contrasts expressed in the film reflects Richter's *own* understanding of Dada as one of balance and harmony among seemingly opposed forces: reason and unreason, conscious and unconscious, nature and technology, etc. As Richter remarks about the film, "one doesn't see the form or the object anymore but rather the relationship. In this way you see a kind of rhythm" (Richter 1997: 132).

Understood in this way, it's no wonder that Richter found company with the loose band of artists and writers associated with the journal, *De Stijl*, edited by Theo van Doesburg (in fact,

¹⁷² Lawder offers an eloquent reading of the film, even suggesting that it is not clear which is foreground and which background. See Lawder, *The Cubist Cinema*, 51.

Richter developed relations with van Doesburg before his work on *Rhythm 21*). The principle exponent of the movement (at least for a period) was the painter, Piet Mondrian, whose metaphysical theory of abstract painting, “neoplasticism,” was based on the utopian belief that through art, human consciousness could understand that all differences—subject and object, spirit and nature, male and female—are resolved into a universal equilibrium. Like Richter, Mondrian thought that the universal could be expressed by bringing opposites into equilibrium through visual art. For Mondrian, unification was achieved through the dual process of “elementerization,” or the reduction of art forms to their most basic and irreducible features, and “integration,” or the unification of these elements into non-hierarchical interrelation.¹⁷³ Thus, Mondrian reduced painting to planes of primary colors (red, blue, yellow) and non-colors (black, white, grey), horizontal and vertical lines, and rectangular areas. It was only through opposition, Mondrian believed, that a deeper harmony emerged, and that aesthetic and spiritual balance could be achieved. There is little doubt, according to Turvey and Lawder, that de stijl deeply influenced Richter’s *Rhythm 21*.

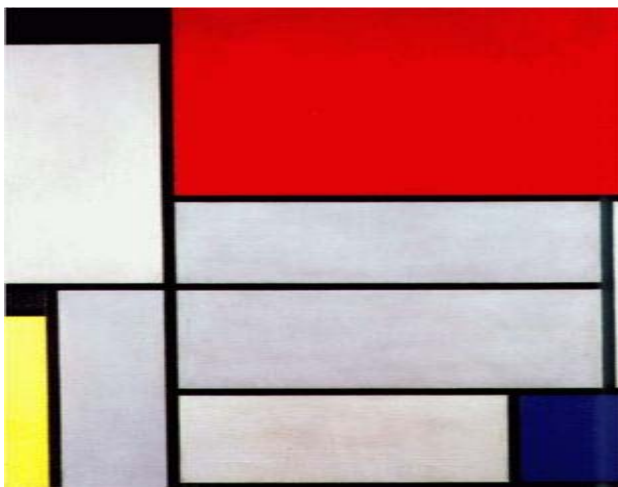

¹⁷³ See Susanne Deicher, *Piet Mondrian, 1872–1944: Structures in Space*.

Figure 28: Piet Mondrain, Tableau 1, 1921.

What matters for us is that there also moments in Painleve's work, such as the mollusk's dance in *Acera or The Witches' Dance*, which seem to express the same kind of "abstract universalism" that we see in Richter and Mondrain. Organic and inorganic, plant and animal—these are differences that seem temporarily insignificant, or in any case, reconciled in into a higher spiritualism. While there is no evidence to support that Painlevé was ever interested in Richter's or Mondrain's work, he was indeed a lover of animation (see above), and unwittingly championed the "plastic qualities" of the cinema. So why not propose that there is an unacknowledged convergence between Painleve and the twentieth century's principle advocate of visual plastics, Piet Mondrain?

As tempting as this may be, there remains an absolutely crucial epistemological difference that prevents such an isomorphism: where Mondrian and Richter believe that human consciousness is able to comprehend the balance underlying the oppositions that plague modern society, Painlevé, by contrast, is firmly against this form of absolutism. For Painlevé, "Nature" is ultimately enigmatic and indeterminate, and what Mondrain and Richter propose imposes a new determinacy on things, a new ultimate reality behind appearances. In short, Mondrain and Richter are far too Hegelian for Painleve.¹⁷⁴ If Painlevé's abstraction is "spiritual," as I suggested above, it's because matter expresses its pure indeterminacy in these moments, its capacity for going outside of itself, for having immaterial relations that are not pre-given in material forms. Abstraction does not impose a new form of determinacy qua absolute consciousness. In the end, Painlevé and Mondrian-Richter differ over the function of abstraction: for the latter, abstraction determines the world,

¹⁷⁴ See Marek Wieczorek, "Mondrian's First Diamond Composition: Hegelian Spatial Totality in the Starry Sky."

makes it understandable; while for the former, abstraction makes judgment impossible, and thus mystifies the world.

Of course the point of our detour into Dalí, Buñuel, Léger, Richter, and Mondrian is to bring Painlevé into conversation with the European avant-garde. While commentators often associate Painlevé's work with the Surrealism—and indeed, Painlevé's own writings make the association (see above)—he never formerly endorsed any avant-garde movement, and I think this is telling: his work borrows from, traverses, and transforms other brands of avant-gardism. Mixing Surrealism and Dada, as well as figurative and non-figurative abstraction, Painlevé's cinema resists tidy labels, and instead borrows and disfigures aspects of each. Of course, art critics might object that this amounts to little more than careless cherry picking. Against these potential detractors, however, I would simply remind them that Painlevé remains unwavering in his commitment to *his* subject matter: namely, the non-anthropocentric study of the natural world; and that it is ultimately *this commitment* that requires him to experiment aesthetically. In other words, Painlevé's principle concern is not art and aesthetics. Rather, the latter are his concern insofar as his subject matter demands to be investigated aesthetically, an investigation which very often finds common ground with, but ultimately does not fit neatly into, the avant-gardist movements of his day. Simply put, Painlevé's work demonstrates how the non-anthropocentric investigation of nature demands taking an aesthetic form, but it is one that is not readymade—it is always under construction.

And, yet, in spelling out the resonances between Painlevé and the avant-garde, there still seems to be one glaring difference. Notwithstanding the anti-fascist reading one could offer *The Vampire*, Painlevé's work appears to be, by and large, “apolitical.”¹⁷⁵ This is in stark contrast to the political motivations that supposedly propelled much of the work labeled “avant-garde.” Of

¹⁷⁵ One might object here that Painlevé spearheaded a number of political campaigns in order to protect documentary and scientific cinema. See Berg, “Contradictory Forces: Jean Painlevé 1902-1989.”

course, there has been significant debate over what avant-gardists were critiquing, and indeed whether many artists were complicit in what they were critiquing.¹⁷⁶ Nonetheless, it's reasonable to assume that despite these contradictions, what concerned avant-gardists, and especially the directors mentioned above, was that modern life, dictated by the values of “bourgeois modernity,” needed to be transformed.¹⁷⁷ And it is precisely this transformation that doesn't seem concern Painlevé.

This still doesn't say much, however. Since just what “bourgeois modernity” means, and what aspects required transformation, were far from settled topics among the avant-garde—and they still aren't. Rather than hopelessly trying to define “Modernity” for them, I follow Malcolm Turvey's helpful strategy and simply list some of the main developments that the term signified for avant-garde artists: industrial capitalism, swift scientific and technological development, globalization, urbanization, rationilazation, individualism, secularlization, and mass consumerism (see Turvey 2011: 4). *Bourgeois* modernity, then, references all those developments under the influence of “middle class” values, or the class of people whose wages and living standards fall somewhere between the working class and the aristocracy. And more than anything else, those values are defined by the use of “instrumental reason” to improve wellbeing, understood as the acquisition of wealth and property.¹⁷⁸ In other words: merciless calculation in the service of material gain. As the historian Peter Gay remarks in his seminal work, *Education of the Senses, The Bourgeois Experience: Victoria to Freud*, “in their crassness, their mechanical rationality, bourgeois converted all of life into merchandise, all of experience into the cool operations of

¹⁷⁶ See for instance, Michael White, *De Stijl and Dutch Modernism*.

¹⁷⁷ Michael White, in the Introduction to *De Stijl and Dutch Modernism*, explains that in bourgeois modernity, art is disconnected from social life; the avant-garde tried to rectify this by connecting art to social realities. Also see Peter Burger, *Theory of the Avant-Garde*.

¹⁷⁸ See Max Horkheimer and Theodor W. Adorno, *Dialectic of Enlightenment*, and Horkheimer, *The Critique of Instrumental Reason*, for an in depth consideration of “instrumental reason.”

adding and subtracting” (Gay 1984: 36). Maximizing profit and minimizing loss—this is the cold, calculating logic to which life was submitted under the bourgeois system of values.

Now, following recent revisionist scholarship by Kenneth Silver, Christopher Green, Romy Golan, and others, Turvey makes the compelling argument that the avant-garde, and especially the cinema, was not simply anti-modern, or even anti-bourgeois as the reigning scholarship in the field suggests.¹⁷⁹ As we already saw, Dalí, Buñuel, Léger, Richter, and Mondrian all embraced aspects of modern bourgeois culture and rejected others. So for example: both Dalí and Buñuel champion mechanical automation, continuity-editing techniques, and the use of stock characters, all of which, it could be argued, breed different kinds of instrumental reason. Similarly, neither Richter nor Mondrian critique the use of “reason” per se, but demand that it find its proper place. Thus, “order” and “balance,” both of which seem to follow from the instrumentalist values of bourgeois culture, were celebrated in their work. The avant-garde is in other words full of complex, conflicting, and often contradictory responses to modernity. Confirming what Michael White argues in his important study, *De Stijl and Dutch Modernism*, the avant-garde does not simply oppose the modern *tout court* —pace Peter Burger’s field-defining work, *Theory of the Avant-Garde*—but continues to engage and transform the questions it raises by placing them in a lived context, in the space of “praxis” (White 2003: 5-6). Where previous scholarship claimed that “the avant-garde rebelled against prior historical styles, against the traditional networks and institutions of the art system ... [and] do away with everything that came before it in one *tabula rasa*—gesture (Turvey 2011: 11), Turvey argues that avant-garde cinema was deeply conflicted by the sweeping changes wrought by modernity, embracing them and undermining them at the same time; transforming aspects of bourgeois culture while keeping

¹⁷⁹ See Peter Burger, *Theory of the Avant-Garde*.

others intact. In short, the avant-garde did not have a uniform way of diagnosing and curing the ills that plagued modern life.

Whatever the reason for the avant-garde's complicated relation to bourgeois modernity,¹⁸⁰ by all accounts the avant-garde is characterized, in the broadest sense possible, by its efforts to undermine the values of bourgeois modernity, even if only in part or by contradictory means. This is important for us since Painlevé's work simply does not appear to have the same political inflections. This should and should not come as a surprise to us. On the one hand, given Painlevé's penchant for the avant-gardist techniques and associations, one might suspect that his work would have a more overt political tone. But on the other hand, Painlevé's principle concern, unlike other avant-garde filmmakers, was not the modern, industrial world per se, but the natural world. Viewed in this way, his concerns could not be further from those of the avant-garde: where Painlevé's work indexes the "natural world," theirs indexes the "artificial world" of machines and industry.

I would nonetheless like to complicate this simple opposition (between the "natural" and "artificial" cinemas) by recalling that Painlevé's work does not champion the "neutral" recording of nature. Much more than this, his work endeavors to dislodge our anthropocentric conception of nature through a variety of cinematic techniques.

At this point it is important to note that many environmentalists argue that the history of anthropocentrism is connected in important ways to the emergence of industrial capitalism. For example, the deep ecology scholar, Andrew McLaughlin, contends that anthropocentrism is the assumption that makes industrialism and instrumental reason possible: only when humans have the greatest value do nonhumans become a resource for human gain (see McLaughlin 1993: 118).

¹⁸⁰ Turvey suggests that the avant-garde's conflicted relation to bourgeois modernity is largely due to the fact that the avant-garde was itself largely bourgeois (Turvey 2011: 12-13).

Deep ecology has received no shortage of criticism in recent years, and it is most often charged with containing unexamined assumptions about industrialism and anthropocentrism, as well as naïve endorsements of ecocentrism/spiritualism (cf. Luke 1999: 153-156; Wolfe 2012). Timothy Luke, for one, wonders whether we could ever really do away with anthropocentrism: “As long as humans are humans, they will be, and can only be, anthropocentric” (Luke 1999: 156); and he accuses McLaughlin of naïve eco-sophistry. Of course, Luke’s criticism harbors its own assumption: namely, that anthropocentrism is a “brute fact” of human nature. Nevertheless, what McLaughlin and Luke can both agree on is that anthropocentrism is a necessary presupposition for industrial capital. But more than this, I would argue that they also agree on the fact that anthropocentrism is not only assumed but also intensified and transformed with industrialism. With such sweeping scientific, technical, and commercial advances, humans are capable of using the nonhuman world in ways that were never before possible.

It is with this in mind, that one might appeal to the recent flood of scholarship on the “Anthropocene” as evidence for how anthropocentrism after industrialization (beginning somewhere in the eighteenth century) has intensified, or in any case, is different than it is in previous epochs: that is to say, industrial-era anthropocentrism has left an unforgettable mark on the Earth’s ecosystems.¹⁸¹ More to the point, what I would like to suggest is that the dominance of bourgeois middle-class values is evidence enough that modern industrialization witnesses an intensification of anthropocentrism: “all of life,” according to Gay, is converted into “merchandise” for the bourgeoisie. Even interpersonal relations could be instrumentalized, according to Marx and Engels, since “the bourgeois sees his wife as a mere instrument of production” (Marx and Engels 1986: 263). It’s not just that the entirety of the non-human world its submitted to human

¹⁸¹ See Will Steffen et al., “The Anthropocene: conceptual and historical perspectives,” and Jan Zalasiewicz et al., “The New World of the Anthropocene.”

calculation, but so is the majority of the human world, since only certain values are considered fully “human”—namely, those held by white, male, landowning citizens.¹⁸²

My larger point here is not simply that anthropocentrism is intensified with middle-class values; rather, what concerns me is that Painlevé’s marked interest in overcoming anthropocentrism cannot be isolated from larger political-economic concerns, inasmuch as his struggle against anthropocentrism is also, and inherently, a struggle to undermine the assumption that makes bourgeois values possible and allows them to thrive. While Painlevé’s work does not raise the question of “the political” per se (and I’m not sure if this is a good thing anyway—see Chapter 4), at the end of the day, it is every bit as concerned with reckoning with the realities shaped by bourgeois modernity as any of the other avant-garde films considered here. From this perspective, Painlevé’s work fits squarely within the “avant-garde,” if by this term we mean “art” that is attuned to transforming the ills of modern life.

But Painlevé’s work is singular among avant-garde cinemas inasmuch its principle concern is neither “aesthetic” nor “political” in any traditional sense. But in order to resist the lures of anthropocentrism in nature, which *is* his most pressing concern, his cinema finds itself in close company with the political aesthetics of the avant-garde. But just what it means to say that aesthetics could be marshaled to dislodge human representation as the supreme value, is far from clear. In other words, is it even possible for there to be a coherent theory of nonrepresentational aesthetics that is politically transformative? It has often been observed that many of the avant-garde’s political and aesthetic objectives were confused or misconceived (cf. White, Burger, Turvey), which is why the avant-garde, according to Burger, is “doomed to fail.” Is Painlevé’s

¹⁸² The difference between industrial and neoliberal (or late capitalism) becomes acute here, since all aspects of human life (including those private spheres that were formally outside of production) are capable of producing value. See Antonio Negri, *Marx Beyond Marx: Lessons on the Grundrisse*.

understanding of political aesthetics somehow better conceived? In other words, does his conception stack up theoretically and practically? Or is it simply too much, as Timothy Luke suggests, to ask any human practice, let alone art, to dislodge the firm grip of anthropocentrism?

Chapter 4: A Case for Cinematic Beauty

In this chapter I show how the questions raised at the end of Chapter 3 reference a much older debate in the history of philosophy over the relation between aesthetics and representation that originates in Kant's First and Third Critiques, but is radicalized in Deleuze's work. What the following discussion will add is a necessary layer of theoretical robustness to our account of how aesthetics can dislodge the privilege of human representation. In particular, the aesthetic will become a virtual specter that haunts human representation insofar as it virtually accompanies it, and undermines its privilege at the same time. This will pave the way for me to resituate Painlevé's work once again, but this time squarely within the history of philosophical aesthetics, and, most importantly, the history of scientific visibility.

With Kant and Deleuze in tow, Painlevé emerges as a firm anchor for a nonrepresentational genealogy of visual science. As we have seen, such an anchor must generate a "visual event" (or "shock to thought") that resists the lures of being identifiable with a pre-given norm or set of values. In short, this form of visibility, which I'm arguing we find in Painlevé, genuinely provides a "lure for feeling" (Whitehead) difference instead of identity. While this "lure for difference" has become almost cliché in the last fifty years of Continental philosophy, to suggest difference exists (or insists) within scientific practice is not widely recognized.¹⁸³ And furthermore, to suggest that this lure is not achieved by means of the philosopher's tools/materials—namely, language—but rather, with technical instruments (camera, etc.) used to produce art within science, generates new

¹⁸³ There are, of course, a number of Deleuze scholars who try to identify the coordinates of "minor science"; this is thanks in large part to Manuel DeLanda's work, especially, *Intensive Science and Virtual Philosophy*. But as will become more apparent, what I'm arguing here differs from much of the Deleuze scholarship in that minor science cannot exist as an "autonomous practice." Thus, cognitive science or systems biology (both of which have been championed for being "minor" or "virtual" sciences) have minor moments, for sure (as all sciences do), but they cannot exist as minor sciences as such.

spaces of disciplinary and material alliance.¹⁸⁴

A further advantage of situating Painlevé's work within this philosophical genealogy will emerge as well: namely, Deleuze's work on nonrepresentational aesthetics raises the question of the political, and the biopolitical, in particular. This will then force us to sharpen our understanding of the political stakes of Painlevé's scientific aesthetics, as well as the inseparability of scientific visibility from political power more generally. While the intimate connection scientific epistemology shares with political power is a well-worn topic in science and technology studies,¹⁸⁵ the political stakes of visual aesthetics' confrontation with representation is not a focal point in the literature.¹⁸⁶ Fleshing out the political stakes of Painlevé's visual aesthetics will then prove advantageous for our return to contemporary molecular visibility in the Conclusion, inasmuch as it sharpens our understanding of how nonrepresentational images can have political potency, which is what we desired for animation all along. As will become clear there, however, this resolution generates a new problem that the dissertation will ultimately leave unresolved: namely, what kind of politics is possible for this model of scientific aesthetics? Of course, my hypothesis has been all along that nonrepresentational images in science undermine neoliberal value production. To test whether nonrepresentational images can indeed have such political force, I reconstruct a genealogy of nonrepresentational scientific aesthetics via Painlevé and Kant/Deleuze, which makes a political intervention. But what comes after the neoliberal control of technoscience is much less clear—and

¹⁸⁴ It seems to me that there is ample work to be done on how my claim resonates, and many ways complicates, Deleuze and Guattari's work on the three daughters of chaos, art, science, and philosophy in *What is Philosophy?*

¹⁸⁵ See Foucault, *The Order of Things: An Archeology of the Human Sciences*; Steven Shapin and Simon Schaffer, *The Leviathan and the Airpump: Hobbes, Boyle, and Experimental Life*; Sheila Jasanoff's edited collection, *States of Knowledge: The Co-Production of Science and Social Order*; Kaushik Sunder Rajan, *Biocapital: The Constitution of Postgenomic Life*.

¹⁸⁶ There are some notable exceptions, of course. See Lisa Cartwright, *Screening the Body: Tracing Medicine's Visual Culture*, and Jose van Dijk, *The Transparent Body: A Cultural Analysis of Medical Imaging*.

may not yet be conceivable¹⁸⁷—than what many imagined possible after industrial capitalism. My intention will not be to leave a gaping hole in the analysis, or to end on a question mark, but to see this problem as a new horizon for thought (Deleuze), or more precisely, a “lure for feeling” (Whitehead) the scientific world differently. But before we can turn to any of these questions, we need establish a more coherent philosophical understanding of nonrepresentational aesthetics, which will lend itself to a more robust understanding of the political. For this, I now turn to Deleuze and Kant.

4.1. Deleuze on Kant on Beauty

In Chapter 1 I briefly alluded to how Deleuze, in *Difference and Repetition*, contends that the “encounter” undermines the different forms of identity operative in each of the faculties. If we return to this idea, Deleuze explains that an “encounter” is “something in the world that forces us to think... this something is the object not of recognition but of a fundamental encounter” (Deleuze 1994: 140). To illuminate this further, Deleuze draws on Socrates’ formulation of two kinds of perception: one in which thought finds its own self-image in something else, which is to say, *recognition*; and the other, which “invite[s] the intellect to reflection because the sensation yields to nothing that can be trusted” (138). The former is identified with what Deleuze calls the “dogmatic image of thought,” or what describes thought’s production of own self-image, and has “nothing to do with thinking” (ibid.); while the latter is identified with those rare occurrences that outstrip thought’s own image of itself, and leaves thought with nothing to fall back on, nothing familiar, nothing to trust. This “shock to thought” does not happen on its own, however, as if thought, in its own solipsism, generated its own outside. No: “Something in the world forces us to

¹⁸⁷ See in particular Mark Fisher, *Capitalist Realism: Is There No Alternative?* and *Ghosts of My Life: Writings on Depression, Hauntology, and Lost Futures*; and Franco “Bifo” Berardi, *After the Future*.

think. This something is an object not of recognition but of a fundamental *encounter*” (139). And such encounters, Deleuze will go on to say, are produced by works of artistic expression, very broadly understood.¹⁸⁸ In the absence of recognition, we encounter “signs” in art, or an assemblage of intensities—percepts and affects¹⁸⁹— that do not reference anything at all—*pace* the dominant notion of “signs.” Rather, and paradoxically, signs can only be *sensed*, but in such a way that there is no being, or thing, to sense. In other words, the sign is not a “sensible being but the being of the sensible” (140).

Before we get too far ahead of ourselves, it’s crucial to point out that Deleuze seems to be making one argument with two separate valences: on the one hand, he makes a very specific claim about art’s privilege—namely, that it emits signs and “confounds” (*sic.*) recognition; and on the other hand, he makes a wholly general claim about art as the ontology of sensibility—“the being of the sensible.” In other words, art somehow operates at the intersection of these two theses: at once a theory of art and a theory of sensibility. Understanding how these theses converge in Deleuze rests on his rereading of Kant’s formulations of the aesthetic in his First and Third Critiques.¹⁹⁰ As I show, Kant provides the backdrop for a Deleuze’s aesthetic ontology that unites these two senses.

According to Deleuze, Kant divides aesthetics into “two irreducible domains: that of the theory of the sensible which captures only the real’s conformity with possible experience; and that

¹⁸⁸ Indeed, artworks are not restricted to formally identified “art pieces.” In *A Thousand Plateaus*, for example, the birdsong is creates an artistic territory. See Elizabeth Grosz, *Chaos, Territory, Earth: Deleuze and the Framing of the Earth* for an account of Deleuze’s natural aesthetics. Also see Stephen Zepke, *Art as Abstract Machine: Ontology and Aesthetics in Deleuze and Guattari*, for a convincing account of how Deleuze and Guattari’s cosmic constructive expressionism is a theory of aesthetics.

¹⁸⁹ See Deleuze and Guattari, *What is Philosophy?*, Chapter 7.

¹⁹⁰ I am deeply indebted to Steven Shaviro’s published and unpublished work for my understanding of Deleuze’s reformulation of Kant. See especially, *Without Criteria: Kant, Whitehead, Deleuze, and Aesthetics*; also see “The ‘Wrenching Duality’ of Aesthetics: Kant, Deleuze, and ‘The Theory of the Sensible’” available at (<http://www.shaviro.com/Othertexts/SPEP.pdf>). In particular, I’m indebted to Shaviro’s careful reading of the two senses of the aesthetic in Kant, and how it is Deleuze navigates this difficult terrain.

of the theory of the beautiful, which deals with the reality of the real insofar as it is thought” (Deleuze 1994: 68). In *The Logic of Sense*, Deleuze bemoans that aesthetics is split in Kant between “the theory of sensibility as the form of possible experience” and “the theory of art as the reflection of real experience” (Deleuze 1990: 260). What Deleuze senses in Kant, however (and especially in Third Critique) are the seeds of a deeper notion of the aesthetic which overcomes this dualism: “Everything changes,” he writes, “once we determine the conditions of real experience, which are not larger than the conditioned and which differ in kind from the categories: the two senses of the aesthetic become one, to the point where the being of the sensible reveals itself in the work of art, while at the same time the work of art appears as experimentation” (1994: 68). As I endeavor to show here, it is by understanding this “deeper” notion of the aesthetic, in which being of the sensible and the work of art converge, that we can re-approach Painlevé’s cinema armed with an aesthetic ontology.

What Deleuze is referencing in Kant are the different formulations of the aesthetic that are found in *The Critique of Pure Reason* and *The Critique of Judgment*, respectively. On the one hand, Kant’s original formulation of the aesthetic comes by way of his theory of sensibility in the First Critique in the section titled, “Transcendental Aesthetic.” There he explains that space and time are the pure a priori forms of sensible intuition. For Kant, space, or the form of “outer” sense, and time, or the form of “inner” sense (see Kant 1965: A 48-49/B 66),¹⁹¹ are a priori, insofar as they are “antecedent to any and every act of thinking” (B 67); pure, insofar as they cannot be derived from experience; and forms of intuition, insofar as they order the manifold of appearance in such a way that is distinct from the way it is done in a concept—they coordinate without *spontaneously* subsuming them. In other words, the forms of intuition are what make the

¹⁹¹ I will use standardized notation for Kant’s *The Critique of Pure Reason*.

receptivity of an object possible, prior to being coordinated into definite relations by the “spontaneity of concepts” (see A 26/B 42; A50/B74). Receptivity is thus the “capacity [of the subject] to be affected by objects” (A 26/B42) by means of the forms of intuition, or “the mode in which the subject is affected,” which yields “the manifold of representations ... which is purely sensible” (B 130). The major challenge that faces the First Critique is describing this combination of sensible receptivity and conceptual spontaneity as the necessary conditions for *possible* experience, especially when Kant refuses to reduce the one to the other—in either empiricism or rationalism.

And then on the other hand, in the *Critique of Judgment* Kant outlines, according to Deleuze, his “theory of art as a reflection of real experience” in Part I, “Critique of Aesthetic Judgment,” by working through his theory of aesthetics insofar as it concerns those rare experiences of the beautiful and the sublime in nature and works of art. Of course, Deleuze is well aware that the *Critique of Judgment* contains much more than a theory of “art” in a narrow sense, and he is thus in agreement with much of the Kant scholarship that seeks to widen the scope of the Third Critique.¹⁹² In fact, what’s largely at stake in the Third Critique is sorting out whether or not the faculty of judgment provides itself with its own a priori principle. In the First Critique, judgment was analogous to a processor of more primary mental presentations: intuitions and concepts. It is for this reason that Kant begins his Third Critique with a definition of judgment as the subsumption of a particular under a universal (see Kant 1952: Introduction, IV); this is what Kant calls a “determinate judgment,” and is fleshed out in the First Critique. “Reflective judgment” on the other hand, occurs when there is no a priori concept, and so judgment must proceed by

¹⁹² It may seem odd to say that Deleuze is in agreement with Kant scholarship, but this is only in the sense that the Third Critique is doing much more than what Kant and Kant scholars identify. In fact, Deleuze will seem to emphasize his aesthetics but this is only insofar as ontology for Deleuze is uncompromisingly aesthetic.

itself, that is, without being the mediator between intuitions and concepts (ibid.). Kant therefore wonders how it is possible for there to be a judgment without a concept. He believes that reflective judgment is therefore the right place to search for judgment's transcendental principle, if there indeed is one, and argues that aesthetic judgments are particularly important forms of reflective judgment, which allow him to explore features about judgment more generally.¹⁹³

In the "Critique of Aesthetic Judgment," Kant's principle task is to understand the features that characterize aesthetic judgments, as well as the principles that ensure their validity. It is for this reason that he tries to account for both beautiful and sublime experiences. To begin with the former, in "The Analytic of the Beautiful" Kant inquires into the conditions for someone to say that something is beautiful, or to have (what he calls) a judgment of "taste." He argues that there are "four moments" to such judgments; there are four distinguishing features, in other words, that make judgments of taste possible. First, he contends that they must be *disinterested*. This means that judgments of beauty must be free of all conceptual and sensuous interests, which are defined by their connection to *real* actions and desires. Kant is thus rigidly formalist in his understanding of beautiful judgments, inasmuch as they concern themselves only with the form of the object (rhythm, shape) instead of its sensible content (tone, color). Second, he explains that judgments of taste must be *universal*. This means that judgments of beauty must be distinguished from my mere subjective enjoyment of an object—the enjoyment I experience tasting chocolate, for example; since, surely, there are those who dislike chocolate. Rather, judgments of beauty demand being treated *as though* they were agreed upon by all, even though there is no concept guaranteeing their objectivity (see Kant 1952: 57-60). Thus, these judgments have no concept but behave "as if" they

¹⁹³ This concern about judgment *as such* is important because it is the mediating link between theoretical and practical philosophy; thus Kant's interest in judgment is about the unification of philosophy in general via an examination of the beautiful, the sublime, and the teleological.

had one: “The beautiful is that which, apart from a concept, pleases universally”(60). Third, judgments of beauty must display *purposiveness* without definite purpose. For Kant, an object’s purpose or end is the concept according to which it is made:

“[a]n end is the object of a concept so far as this concept is regarded as the cause of the object (the real ground of its possibility)” (61). An object that has purposiveness, on the other hand, designates an object that seems or appears to have a purpose without definitely having one. Kant writes:

But an Object, or a state of mind, or even an action, is called purposive, although its possibility does not necessarily presuppose the representation of a purpose, merely because its possibility can be explained and conceived by us only so far as we assume for its ground a causality according to purposes, i.e. a will which would have so disposed it according to the representation of a certain rule. There can be, then, purposiveness without purpose... (Kant 2012: 41).¹⁹⁴

According to Kant, beautiful objects must therefore be “purposive without a purpose,” that is, appear to have a purpose but not according to a definite cognition of one. And fourth, judgments of beauty must be *necessary*. Essentially, Kant is trying to delimit the necessity of such judgments, that is, how it is they follow according to “principle” without there actually being one. What is it, in other words, that guarantees the necessity of beautiful judgments? Kant will say that it is “common sense,” which is the necessary presupposition of beautiful judgments: “[t]he judgment of taste, therefore, depends on our presupposing the existence of a common sense. (But this is not to be taken to mean some external sense, but the effect arising from the free play of our powers of cognition.) Only under the presupposition, I repeat, of such a common sense, are we able to lay down a judgment of taste” (Kant 1952: 83). And, yet, Kant goes onto ask:

But does such a common sense in fact exist as a constitutive principle of the possibility of experience, or is it formed for us as a regulative principle by a still higher principle of reason, that for higher ends first seeks to beget in us a common sense? Is taste, in other words, a natural or original

¹⁹⁴ I’ve decided to use J. H. Bernard’s translation of this passage instead of James Creed Meredith’s, mainly because the former translates the German, *Endzweck*, as “purpose,” instead of “end,” which is more consistent with how the Anglophone scholarship discusses the Third Moment of in the “Analytic of the Beautiful.”

faculty, or is it only the idea of one that is artificial and to be acquired by us, so that a judgment of taste, with its demand for universal assent, is but a requirement of reason for generating such a *consensus*, and does the “ought,” i.e., the objective necessity of the coincidence of the feeling all with the particular feeling of each, only betoken the possibility of arriving at some sort of unanimity in these matters, and the judgment of taste only adduce an example of the application of this principle? These are questions which as yet we are neither willing nor in a position to investigate. For the present we have only to resolve the faculty of taste into its elements, and to unite these ultimately in the idea of a common sense (1952: 85).

In some ways, cognition of the beautiful is similar to what happens in ordinary cognitions, it’s just that in the former case intuitions are without a concept, and are therefore granted “free play,” but according to the “lawfulness” of the understanding in general and not one concept in particular; and striking a “harmony” between free play and the understanding is Kant calls “common sense.”

The sublime, on the other hand, marks the other pole of aesthetic judgment that disrupts rather than harmonizes cognition. Sublime experiences for Kant are marked by our inability to grasp the magnitude, extent, or force of a situation. Extreme weather, the vastness of the desert, the enormity of the sky—these are all such inexplicable occurrences: they disturb ordinary cognition and are impossible to fit into a determinate concepts. In other words, they index a limitation in us. In short, sublime experiences seem to undermine *our* ability to see “purposiveness” in nature: “we express ourselves on the whole inaccurately if we term any *Object of nature* sublime ... For how can that which is apprehended as inherently contra-final be noted with an expression of approval? All that we can say is that the object lends itself to the presentation of a sublimity discoverable in the mind” (Kant 1952: 91-92). Kant will thus say that sublime experiences are of two sorts: they’re either “mathematical,” that is, overwhelm by means of magnitude (see sections 25-27); or “dynamical,” that is, overwhelm by means of force (see section 28).

What's crucial for Kant is that sublime experiences are not actually attributable to the objects themselves—the desert, the sky, the weather; rather, they come from the Ideas of Reason: “For the sublime, in the strict sense of the word, cannot be contained in any sensuous form, but rather concerns ideas of reason...” (1952: 91). The vastness of the desert is nothing in comparison to Idea of absolute totality; or again, the overwhelming force of the hurricane is nothing in comparison to the Idea of absolute freedom. In short, sublime experiences are really not about the sensible object at all, but about the overwhelming nature of the Ideas of Reason. This is why Kant argues that objects of sense are only inaccurately called “sublime,” since it is only “attribute [the sublime] to an Object of nature by a certain subreption ...” (106). It is therefore more accurate to say that being overwhelmed by a sensible object leads us to the Ideas of Reason, which induce in us an experience of the sublime: there is an Idea for which there is no sensible object. Or again, there is an excess of the Idea over the intuition. Given this, one might assume that having a sublime experience would induce in us a feeling of terror or fright, but Kant will say that sublime very often produces pleasure (see section 28). Why is this? In short, initial experiences of violence are actually pleasurable on a higher level, since the presentation of the Ideas (albeit negatively) allow the sensible faculties to discover a “supersensible vocation” (see section 27), which is pleasurable for the subject.

While there is far more that could be said about aesthetic experiences, suffice it to say that aesthetical judgments are of two sorts in Kant: they are beautiful inasmuch there is a sensible intuition without a concept; and they are sublime inasmuch as there is a concept without a sensible intuition.

In his important work on the reception of Kant's aesthetics in twentieth-century philosophy, Steven Shaviro compellingly shows how the sublime has been actively incorporated

into Continental aesthetics while the beautiful has been readily denounced.¹⁹⁵ The principle exponent of this view is Jean-Francois Lyotard, who writes that the sublime

would be that which in the modern invokes the unrepresentable in presentation itself, that which refuses the consolation of correct forms, refuses the consensus of taste permitting a common experience of nostalgia for the impossible, and inquires into new presentations – not to take pleasure in them, but to better produce the feeling that there is something unrepresentable” (Lyotard 1993: 15)

Lyotard’s willful embrace of the sublime is completely understandable of course, given that the concept testifies to the limits of representation, which has been a principle concern for Continental philosophy since its inception. Indeed, Lyotard continues: the “true sublime feeling...is intrinsically a combination of pleasure and pain: pleasure in reason exceeding all presentation, pain in the imagination or sensibility proving inadequate to the concept” (ibid.; also see Jameson 1991). The beautiful on the other hand, promotes “universality,” “harmony,” and “common sense,” all of which seem to reinforce the values of bourgeois modernity, values for which Kant has often been accused of championing.¹⁹⁶

Deleuze is certainly aware of all of these shortcomings in Kant—after all, he contends that his book on Kant is work on an “enemy”¹⁹⁷— and yet he (along with Whitehead) is no less intrigued by what remains dormant in Kant’s theory of the beautiful. Adding to this claim, Shaviro argues that Lyotard overlooks how the beautiful no less than the sublime involves the incompatibility between intuitions and concepts.¹⁹⁸ What often goes unnoticed is that the sublime leads us the superiority of mind, and so also back to the practical subject of *The Second Critique*: the subject discovers that nature “is here called sublime merely because it raises the imagination

¹⁹⁵ See Shaviro, *Without Criteria: Kant, Deleuze, Whitehead, and Aesthetics*.

¹⁹⁶ See especially, Friedrich Nietzsche, *The Anti-Christ* and *The Genealogy of Morals*.

¹⁹⁷ See Deleuze, *Kant’s Critical Philosophy: The Doctrine of the Faculties*, xv.

¹⁹⁸ See Shaviro, “The ‘Wrenching Duality’ of Aesthetics: Kant, Deleuze, and ‘The Theory of the Sensible.’”

to a presentation of those cases in which the mind can make itself sensible of the appropriate sublimity of the sphere of its own being, even above nature” (1952: 111-112). The sublime thus belongs to human *freedom*, which is the cornerstone of Kant’s moral theory.¹⁹⁹ The beautiful, on the other hand, concerns the excess of sensible intuition over the concept. Beauty does not have a concept that is adequate to it; there is no pre-determined meaning or designation for the intuition—the understanding faces its own limitations here. And yet a judgment of beauty requires more than my subjective feelings, my mere delight in this or that intuition—it demands agreement from others. But finding the conditions for universal appreciation, *which must be sought*, are nonetheless impossible to find. This is precisely why Shaviro will claim that the “Analytic of the Beautiful” poses a “problem” in the Deleuzian sense.²⁰⁰

Much more crucially however, Kant’s notion of the beautiful also resonates with the “Transcendental Aesthetic” from the First Critique, and begins the difficult work of combining Kant’s two understandings of the aesthetic. Recall that for Kant the outer and inner forms of intuition, space and time, are non-cognitive and pre-conceptual. While they are necessary for cognition—i.e., Kant’s famous dictum: “Thoughts without intuitions are empty, *intuitions without concepts are blind*” (Kant 1965: B 75)—they must still be rigorously distinguished from cognitions. The forms of intuition are the “modes” of receptivity of the object (B 130), which must be contrasted to the “spontaneity of concepts” (A 26/B 42; A50/B74). Sensibility has to do with “the appearance of something, and the way we are affected by that something”(1996, 96; italics added) rather than with how that something is thought through the straightjacket of a priori concepts.

Kant’s “Analytic of the Beautiful” expresses a similar insight: namely, that there is an

¹⁹⁹ See Kant, *The Groundwork of the Metaphysics of Morals*.

²⁰⁰ See Shaviro, “The ‘Wrenching Duality’ of Aesthetics: Kant, Deleuze, and ‘The Theory of the Sensible.’”

irreducible difference between intuitions and concepts. But what the Third Critique articulates that the First does not, and perhaps cannot given its constraints, is the fundamental excess of sensible intuitions over concepts: that there is no concept adequate to this way of being affected by the world. Recall that what Kant makes clear in the First Critique is that judgment operates in a fairly straightforward manner inasmuch as it allows for “thinking the particular as conditioned under the universal” (Kant 1952: 18). But in the Third Critique, things are not smooth and orderly for judgment: it no longer has ready-made concepts that it can apply to intuition. Deleuze notices this incommensurability among faculties in his book on Kant: “each [of the faculties] goes to its own limit” he explains, and they

struggle against one another, the one pushing the other to its maximum or limit, the other reacting by pushing the first towards an inspiration which it would not have had alone. Each pushes the other to the limit, but each makes the one go beyond the limit of the other” (Deleuze 2008: xi-xii).

But even if we affirm the resonances between the First and Third Critiques, there is still a wide chasm that separates them: there is the smooth transcendental ordering of the faculties, on the one hand; and the dissonance among faculties, on the other. Kant cannot bridge this gulf alone. His conception of the transcendental requires reassessing, or re-valuing, which is precisely what Deleuze does in a number of his texts (though most notably in *Kant’s Critical Philosophy* and *Difference and Repetition*), and it a reassessment that, in his estimation, permits the co-alignment of Kant’s two notions of the aesthetic.

While Deleuze calls his book on Kant a “book on an enemy,” and he moreover argues that “common sense” (which is so crucial for Kant) is one of the two pillars of the “dogmatic image of thought” (see Deleuze 1994: 33),²⁰¹ in recent years Deleuze scholars have begun to unpack just

²⁰¹ See Gregg Lambert, *In Search of a New Image of Thought: Gilles Deleuze and Philosophical Expressionism*, and Gregg Flaxman, *Gilles Deleuze and the Fabulation of Philosophy*.

how complicated Deleuze's debt to Kant really is. So for example, it has become increasingly clear that central notions in Deleuze's oeuvre, such as "transcendental empiricism," the "virtual," and the "Idea," are all derived from Kant. This fact has led many Deleuzians to insist that Deleuze is less of an anti-Kantian than he is a *neo-Kantian*, though of a very peculiar stripe.²⁰² In any case, the complications of Deleuze's debt to Kant are well rehearsed in the secondary literature, and thus don't need to be spelled out in great detail here. What I will review are some of the most salient features of Deleuze's reworking of Kant's transcendental thesis in the First Critique in order to show how it may be reunited with the beautiful in the Third Critique.

In *Difference and Repetition* Deleuze makes his debt to Kant clear when he credits Kant with discovering the "transcendental realm" (Deleuze 1994: 135). The problem for Deleuze is that Kant misunderstood the full implications of the "prodigious realm of the transcendental" (143). In the first place, Deleuze argues that in order to account for the conditions of the given (as Kant tries to), those conditions cannot replicate or imitate what it is they're supposed to condition. In other words, Deleuze accuses Kant of forming the transcendental on the image of the empirical, which it is supposed to explain. Kant thus "traces the so-called transcendental structures from the empirical acts of a psychological consciousness" (ibid.), and so illegitimately "traces ... the transcendental from the empirical" (ibid.). Condition and conditioned cannot then resemble each other, which is to say, they must be "heterogeneous," though they must interact with each other. Deleuze calls these two realms the "virtual" and "actual" after Henri Bergson.²⁰³

Of course any full account of Deleuze's reframing of Kant would have to reckon with how the transcendental synthesis is reframed by Deleuze in terms of the three *passive* syntheses of time

²⁰² See Shaviro, *Without Criteria: Kant, Deleuze, Whitehead, and Aesthetics*; James Williams, *Gilles Deleuze's Philosophy of Time: A Critical Introduction*; Daniel W. Smith, "Genesis and Difference: Deleuze, Maimon, and the Post-Kantian Reading of Leibniz."

²⁰³ See Deleuze, *Bergsonism*.

in *Difference and Repetition*.²⁰⁴ For our present purposes though, it's sufficient to highlight that heterogeneity, or asymmetricality, in this case means that the laws and processes that constitute the two realms are radically different.²⁰⁵ More concretely, this means that the transcendental field of the virtual cannot model or replicate in any way the empirical world of sense perception in the living present: the determinate subjects and objects that populate the latter cannot be duplicated in the former. And this is precisely the point that Kant misses. The transcendental for him mimics the empirical, which is exemplified by the pure "I" in the "transcendental unity of apperception," and entails that the transcendental "retains the form of the person, of personal consciousness, and of subjective identity" (Deleuze 1990: 98). Kant therefore pre-figures the form of all *possible* experience, but at the expense of ever having a new experience, since the form experience takes is already given, it's just that it has yet to become *real*.²⁰⁶

Deleuze knows better than this however, which is why he requires that the transcendental not take the form of a subject or an object. Thus, the quasi-mystical language that often surrounds Deleuze's discussion of the "virtual" is born out of a philosophical constraint rooted in Kant:²⁰⁷ namely, that the transcendental *must be* a pre-subjective and pre-objective field of non-identifiable multiplicities, which he will call "Ideas" after Kant (see below). In Deleuze's own words, the virtual is "an impersonal and pre-individual transcendental field, which does not resemble the corresponding empirical fields" (1990: 102). Or again, and much later on, in response to his own question, "What is a Transcendental Field?," Deleuze answers: "It can be distinguished from experience in that it doesn't refer to an object or belong to a subject. It appears therefore as a pure

²⁰⁴ There, Deleuze demonstrates the interdependency of Hume's habit of the present, Bergson's pure past, and Nietzsche's eternal return. See *Difference and Repetition*, Chapter 2.

²⁰⁵ See *Difference and Repetition*, Chapter 5, "Asymmetrical Synthesis of the Sensible."

²⁰⁶ Deleuze's critique of "possibility" is well known and is perhaps most famously crafted in his book on Bergson, *Bergsonism*.

²⁰⁷ See Peter Hallward, *Out of this World: Deleuze and the Philosophy of Creation*.

stream of a-subjective consciousness, a pre-reflexive impersonal consciousness, a qualitative duration of consciousness without a self” (Deleuze 2005: 25).

But even if Deleuze has sketched an alternative to Kant’s transcendental redundancy, his work is not done yet: he must still explain how it is possible for the transcendental field to be the condition for actual experience when (a) the two realms are asymmetrical, and (b) there one does not prefigure the other. In other words, how does a seemingly indeterminate chaos give rise to the world of individuated beings? To navigate this, Deleuze relies on various sources from the history of philosophy,²⁰⁸ but returns once again to Kant. He argues that Kant’s notion of the “regulative idea” captures the way in which multiplicities in the virtual are perfectly “objective and undetermined” (though not to be confused with determinate objectivity) (Deleuze 1994: 169).²⁰⁹ Virtual Ideas are “object[s] which can neither be given nor known” but whose indeterminacy “is a perfectly positive, objective structure which acts as a focus or horizon within perception” (ibid.). The problem Deleuze now faces is explaining how it is that the indeterminacy of Ideas gives rise to the determinacy of the world of objects without the former prefiguring how the latter are determined.

Deleuze argues that Ideas have a “problematic” structure²¹⁰ insofar as Ideas gain determinacy through the process of actualization (which he will call “individuation” after Gilbert Simondon in order to highlight how the transcendental is a metastable field of potentials that can be energized to determinacy without preformation²¹¹), but they are never completely determined

²⁰⁸ Most notably, Leibniz, Kant, Maimon, and Simondon. See Deleuze, *Difference and Repetition*, and Daniel W. Smith, “Genesis and Difference: Deleuze, Maimon, and the Post-Kantian Reading of Leibniz.”

²⁰⁹ Deleuze is critical of Kant’s understanding of the idea, arguing that he doesn’t go far enough. In other words, there are only certain Ideas in Kant, self, God, etc., and thus, “there is still too much empiricism in the Critique” (Deleuze 1994: 170).

²¹⁰ Deleuze writes that “Kant never ceases to remind us that Ideas are essentially ‘problematic.’ ... Ideas have a perfectly legitimate ‘regulative’ function in which they constitute true problems or pose well-founded problems” (Deleuze 1994: 168).

²¹¹ See Deleuze’s discussion of Simondon in *Difference and Repetition*, 246.

or solved—the solution is not already contained in the problem.²¹² Complete determination of the problematic Idea is irresolvable, an ideal, which means that the determinacy of the Idea is an ongoing and evolving problem. In this way, Ideas do not prefigure or prescribe their own determination, as if they were conditions of *possible* experience; their determination emerges through the process of actualization itself. *Actualization* is a process that determines the virtual as much as it does the objects of the world. This is why Deleuze calls actualization a process of “reciprocal determination”: the virtual and actual determine each other (see 1994: 223).

What is striking here is that through his re-appropriation of the Kantian Idea, Deleuze is able sketch an answer to how it is possible for the transcendental condition to determine the given without pre-figuring it. Through the logic of “reciprocal determination” the virtual and actual determine each other. The given generates its own conditions for emergence anew each time. This is why Deleuze will say that the conditions for *real* (instead of possible) experience “are no larger than the conditioned” (1994: 94). For Kant, on the other hand, there can be no transformative relation between the given and its condition, since the latter provides the laws that determine a priori how the given is given.

Crucially, by re-conceptualizing the transcendental in this way Deleuze has also, and most importantly for us, brought the First and Third Critiques into closer proximity. What Kant articulates about beautiful experiences—namely, that there is a sensible experience for which there is no prior concept—now extends to all of experience: there is no conceptual framework that prescribes in advance the conditions for that experience. Judgment no longer has the easy task of

²¹² Deleuze writes that, “[f]or every solution presupposes a problem—in other words, the constitution of a unitary and systematic field which orients and subsumes the researches or investigations in such a manner that the answers, in turn, form precisely cases of a solution. Kant even refers to Ideas as problems ‘to which there is no solution.’ By that he does not mean that Ideas are necessarily false problems and thus insoluble but, on the contrary, that true problems are Ideas, and that these Ideas do not disappear with ‘their’ solutions, since they are the indispensable condition without which no solution would ever exist” (Deleuze 1994: 168).

mediating between intuitions and the concepts to which they belong. Thus, Kant was onto something when he wrote in “The Analytic of the Beautiful” that there are intuitions that don’t have concepts adequate to them. What he didn’t realize is that this is true of sensible experience more generally. The seeds of this insight are of course already in the “Transcendental Aesthetic,” insofar as it accounts for those modes of receptivity, or being affected, by the world that are distinct from cognitive ones.²¹³ It’s just that emphasis in Kant tends to fall on the spontaneity of cognition instead of the receptivity of sensible intuition. But this is precisely where Kant went wrong in Deleuze’s view. In fact, Whitehead had already noticed this limitation in Kant in his expansive work, *Process and Reality*. There he explains that

In any metaphysical scheme founded upon the Kantian or Hegelian traditions, experience is the product of operations which lie among the higher of the human modes of functioning. For such schemes, ordered experience is the result of schematization of modes of *thought*, concerning causation, substance, quality, quantity... The exception is to be found in Kant’s preliminary sections on ‘Transcendental Aesthetic,’ by which he provides space and time... Thus in the organic philosophy Kant’s ‘Transcendental Aesthetic’ becomes a distorted fragment of what should have been the main topic (Whitehead 1978: 113).

In Deleuze’s language, “[e]verything changes once we determine the conditions of real experience, which are no larger than the conditioned and differ in kind from the categories” (DR 1994: 68); only then, he continues, do Kant’s “two senses of the aesthetic become one” (ibid). That Kant’s insights on the beautiful apply more generally, which is to say, that the two aesthetics are actually one, is not something that we recognize and identify in the world. This would defeat the whole purpose. Ready-made concepts and methods only stifle this awareness. This is why Deleuze firmly believes that it is only artistic experimentation that reveals the being of sensible experience.²¹⁴ “the being of the sensible reveals itself in the work of art, while at the same time

²¹³ See Shaviro, The ‘Wrenching Duality’ of Aesthetics: Kant, Deleuze, and ‘The Theory of the Sensible.’”

²¹⁴ It should be noted that in French, *expérience*, also has the connotation of *experiment*, which we loose in the English. Hence Deleuze writes that, “[t]here is a crucial experience of difference and a corresponding experiment:

the work of art appears as experimentation” (ibid). Artistic experimentation is the means by which “encounters” (to return to our previous discussion) are produced, overwhelming all previous categories and yielding the “being of the sensible.” It’s crucial to realize here that Deleuze is not simply championing “art works” in the narrow sense—even though he is no stranger to the accusation of elitism²¹⁵; much more than this, he is advocating an artistic sensibility, an aestheticized way of letting the world affect us. If our mediation on Kant has taught us anything it is that aesthetic experience is not restricted to a specific set of objects, since the generative conditions of actualization are themselves aesthetic in the sense of the Third Critique. Deleuze is arguing that the aesthetic mode of contemplation *is* a work of art, and it so happens that this contemplation often promoted in literature, films, and paintings; but it need not. Walks through the city, as Guy Debord and the Situationist International recognized, can be works of art²¹⁶; but so can the “bird song,” as well as countless other kinds of organic and inorganic behavior.²¹⁷

4.2. Bio(im)political Aesthetics

The crucial point is that Deleuze has turned Kant’s narrow conception of the beautiful into the basis for an aesthetic ontology, which allows us to return to Painleve’s work with fresh eyes. As we have seen, Painleve does not champion the ideals of the avant-garde in the way Dali, Richter, and others seem to; and yet he somehow manages to express those ideals in his work, and maybe better than anyone else. We know that Painlevé remained a committed “scientist” throughout his

every time we find ourselves confronted or bound by a limitation or an opposition, we should ask what such a situation presupposes. It presupposes a swarm of differences, a pluralism of free, wild or untamed difference...” (Deleuze 1994: 50). Also see James Williams, *Gilles Deleuze’s Difference and Repetition: A Critical Introduction and Guide*, 76.

²¹⁵ See Slavoj Žižek, *Organs Without Bodies: On Deleuze and Consequences*, 20.

²¹⁶ See *Guy Debord and the Situationist International: Texts and Documents*, edited by Tom McDonough.

²¹⁷ See Deleuze and Guattari, *A Thousand Plateaus*, “The Refrain.”

career, passionately pursuing the contemplation of nature released from the firm grip of anthropocentrism. Surrendering himself to this principle task also meant that he constantly needed to experiment. Painlevé knew that there was no simple recipe for dislodging such a well-worn habit of thought. (If nothing else, Chapter 2 should have demonstrated that rooting out the privilege of human representation is not easily done; just when you think it has been undermined, it reasserts itself, as in both microcinematography and nanoimaging.) Sometimes disarming anthropocentrism required non-figurative abstraction; at other times, it required the violent confrontation of images; and at other times, it demanded wry commentary.

Thus, if there is inconsistency in Painlevé's style, it is only because there is a much deeper, imperceptible consistency to his method: treat each situation as radically new. But to commit oneself in this way also means that each situation requires new tools, techniques, and strategies to unleash the event's potential to confront us with what is non-cognizable in it—or in other words: to confront us with its transcendental genesis. Put another way, Painlevé's cinema is a “transcendental cinema” in the sense that it experiments on conditions, unleashing what is singular in them, and thus frustrating any attempt to root them in what is already known—“common sense” and “good sense”. His transcendental cinema experiments to produce an image of pure difference within the biological world.

In these moments, Kant's notion of “purposiveness” is all-important here since we can no longer find a purpose for behavior—it cannot be coordinated into another meaningful action. In the language of Deleuze's cinema books, the sensori-motor schema experiences a breakdown and yields “pure optical and sound situation[s]” that do “not extend into action, any more than it is induced by an action” (Deleuze 1989: 18). And in Painlevé's cinema specifically, organisms appear without a purpose, without meaningful organization, and without a reliable context to

authorize our judgment about them. Framed in this way, Painlevé expresses in the biological world what Deleuze means by “a Life.” A life, explains Deleuze in his last essay, “Immanence: A Life,” is expressed when “the life of the individual gives way to an impersonal and yet singular life that releases a pure event freed from the accidents of internal and external life, that is, from the subjectivity and objectivity of what happens” (Deleuze 2005: 28). A Life is another name for the transcendental field that expresses itself when the subjects and objects of action break down, when they become indiscernible, and a “germinal, and intensive, a powerful life without organs, a Body that is all the more alive for having no organs...passes between organisms” (Deleuze and Guattari 1987: 499). In this way, biology gives way to Life.

My working hypothesis then is that in order to dismantle the firm grip that anthropomorphism has on the human cognition of nature, Painlevé is led to experiment with what might be called a “transcendental cinema” that unleashes the aesthetic Life of the biological world. Of course, Kant had already intimated a connection between Life and aesthetics in the Third Critique (“teleological judgments” are after all a kind of reflective judgment), though certainly not in the way that I’m suggesting here. If Painlevé is an inheritor of Kant, then it is only in the sense that he transforms Kant’s intuitions to make aesthetics and Life cohere in the artistic contemplation of the biological world.

What still remains completely unclear, however, is the political implications of reframing Painlevé’s work in this way. As we know from Chapter 3, it would be a complete oversight to label Painlevé’s cinema, “a-political,” if by this we mean that his work is not as overtly “political” as Dada, etc. In fact, Painlevé was singularly committed to overcoming the well-worn assumption that was a pre-condition for bourgeois modernity: anthropocentrism. Within this narrow view, Painlevé’s cinema seems political enough. And, yet, just what this “politics” amounts to is

certainly not spelled out. So for example, nowhere does he offer a political “critique” of bourgeois capitalism in any straightforward way, replacing the values of consumption with workers’ values, for example. In fact, Painlevé’s work seems neither to propose nor to imply anything that could be used for a political (re)solution. In other words, how could there be a political aesthetics that does not offer a transcendent place from which to critique? Or more precisely, can we call Painlevé’s cinema “political” when it does attempt to neutralize the conflicts wrought by bourgeois capital?

Timothy Campbell has recently shown that it is the “neutralization of conflict” that underwrites political thought in the West. Drawing on Roberto Esposito’s *Nine Thoughts of the Political* (*Dieci Pensieri sulla politica*), Campbell argues that historically (from Plato and Aristotle, to Hobbes, and on through Freud) politics “attempt[s] to represent conflict symbolically and in so doing to continue to neutralize those conflicts that threaten the political order. In short attempting to represent conflict symbolically in language has the effect of immobilizing conflict.”²¹⁸ For both Campbell and Esposito, the political’s main function is to disavow conflict by symbolizing it (especially pronounced in Hobbes²¹⁹). This means that “political philosophy,” according to Campbell, “forgets (one is tempted to say immunizes) its shared horizon with what cannot be represented, with what Esposito will repeatedly refer to as the unthought of the political: conflict.”²²⁰ Conflict, or the “unthought” of the political, is what Esposito calls the “impolitical.” Where the political seeks to synthesize conflict into a political ordering, the impolitical, whose

²¹⁸ This is taken from Timothy Campbell’s unpublished work, “Genres of the Political: The Impolitical Comedy of Conflict,” compiled for the “Society for the Study of Bio-Political Futures” inaugural meeting in 2013: “Life In-Between-Outside: Discipline and Control,” available at: <http://www.biopoliticalfutures.net/>

²¹⁹ Esposito writes that, “It is precisely this question of the compatibility of conflict and politics that is the object of Hobbes’s polemic. There is either politics or there is conflict. The transition or better the jump from the natural state to that of the civil state places the division along a temporal line: when there is conflict there still is no politics. When there is politics, no longer is there any conflict.” In Roberto Esposito, *Ordine e conflitto. Machiavelli e la letteratura politica del Rinascimento italiano* (Naples: Liguori, 1984), 187 (translated by Timothy Campbell).

²²⁰ See Campbell, “Genres of the Political: The Impolitical Comedy of Conflict,”

genealogy is traced back to Machiavelli, composes conflict without neutralizing it in representation. It is this unthought ground of the political, the impolital, that is reduced, neutralized, and silenced as “the political’s irrepresentable foundation.”²²¹ Conflict appears or is represented within the political only insofar as the political is immunized from the vicious bite of the conflict since it threatens political order as such.

Citing Esposito again, Campbell draws our attention to an important passage from *Nine Thoughts*, taken from the chapter titled “Work,” that discusses how we are to conceive of an “impolitical practice”:

[T]he very same impolitical, in order to be practicable or practiceable, cannot be subtracted completely from the form of myth, but at least from its presumed objectivity. For this reason the impolitical isn't really outside of representation; the impolitical also represents or at least represents itself. And yet representing itself, its absence of work, its inactivity, the impolitical represents the unrepresentable. Indeed: it is the "Unrepresentable." Co-belonging to action, practicing action, acting as inaction, the impolitical for a moment suspends the myth of action, that is to say its work of completion ... It is a passive action, outside of work, inoperative.²²²

It is crucial that Campbell takes the strong connection established between inaction and impolitical conflict and ties it to Esposito’s later work on the “impersonal” in *Bios: Biopolitics and Philosophy*, and other works. What Campbell notices is that the person and the personal are virtually synonymous with the political for Esposito (which should come as no surprise, according to Campbell, given Carl Schmidt’s derivation of the political from friend and enemy relations [see Campbell 2013]), and that the impersonal best describes the “acting as inaction” that “suspends the myth of action.” Inaction suspends the myth of the subject’s directed action and composes a “co-belonging to action” instead. Hence, there must be an “impersonality” to inaction. Within this

²²¹ Esposito, *Dieci Pensieri sulla politica* (Bologna: Il Mulino, 1993), 31, in Campbell 2013. Concepts like “foundation” and “ground” need to be qualified here. Since the political and the impolital are not strictly opposed in any straightforward way.

²²² Esposito, *Dieci pensieri sulla politica*. Bologna: Il Mulino, 1993, 169, in Campbell 2013.

intellectual genealogy, impersonal inaction is constitutive of impolitical conflict that is the unthought ground of the political.

By framing things in this way, it's hard not to read Esposito's later work on *communitas*, *immunitas*, and the biopolitical in terms of the impersonality of the impolitical.²²³ In these later works, "communitas" names the condition of "binding ...members to a reciprocal donation," a bond of reciprocal "gift giving" (Esposito 2008: 50); it is a giving in which "one is obliged," according to Esposito in *Communitas*, "to return the onus, in the form of either goods or services [officium]" (Esposito 2009: xiii). The gift names not the gift that one receives from another, but the gift one is obliged to give to another. The gift never belongs to an individual, or a self, it is always given to another— a *munus* that undermines all efforts to identify what is "mine" and "yours." *Communitas* therefore designates the gift that belongs to no one, without origin, it is the pure relation that is in excess of all possessive subjects.

Immunitas, on the other hand, designates having received a *dispensatio* "from the weighty obligation" of the common *munus*, and is therefore "the defense against the expropriating features of *communitas*" (2008: 50). *Immunitas* refers to someone who has no *pensum*, no task nor duty, to offer gifts or perform services to others, which others must perform. *Immunitas* thus inscribes a defense against the loss of identity in the common *munus*, by articulating what is "one's own," restoring borders over against risky contact with those who lack it. And yet *immunitas*, precisely insofar as it is a defense against the desubjectivizing features of *communitas*, presupposes it, so that there is no *immunitas* without the *communitas* that it negates. But "to survive, the community, every community, is forced to introject the negative modality of its opposite, even if the opposite remains precisely a lacking and contrastive mode of being of the community itself" (52).

²²³ See Esposito, *Immunitas: The Protection and Negation of Life*; *Communitas: The Origin and Destiny of Community*; and *Bios: Biopolitics and Philosophy*.

Impersonality therefore describes the bond of *communitas*, or that form of relation that overwhelms every boundary and every instance of order. Politics, or immunization, is the neutralization of this threat—or in other words: the *communitas* that is in conflict with self-preservation. We might argue then that *communitas* is the original conflict of that ignites any form of political order precisely insofar as the former threatens to consume latter. To preserve order, the threat must be re-presented to the political system in such a way that that latter is able to protect and preserve itself against it, that is to say, immunize itself from it. The political *just is* the practice of immunization (The Nazi state is of course the perverse exemplification of this principle.²²⁴). In this way, *communitas* becomes the impolitical foundation of the political.

In *Bios*, Esposito explicitly link his conception of *communitas*, or what he argues must be affirmed within the political to avoid thanatopolitical violence, to more specific and robust notions of embodiment, collectivity, and the norm. This plays out in terms of Esposito's appropriation of Merleau-Ponty's notion of the "flesh," Gilbert Simondon's conception of the "transindividual," and Spinoza's immanent production of the "norm."²²⁵ At stake in this grand synthesis is discovering dispositifs that are capable of affirming the (impolitical) threat of the common in order to reverse the history of biopolitical violence wrought by trying to immunize against it. But after discovering a set of dispositifs that authorize this affirmation, Esposito writes that "all the threads we have woven to this point under the sign of an affirmative biopolitics" are found in Deleuze's last text, "Immanence: A Life" (Esposito 2008: 191). At the end of the day, a Life is the impersonal and disinterested form of connectivity that is capable of affirming all lives. A Life undoes every distinction within life that would form the basis for exclusion. To affirm a Life is thus to affirm a conception of the common that overthrows any possibility for biopolitical violence.

²²⁴ See Esposito, *Bios: Biopolitics and Philosophy*, Chapter 4.

²²⁵ See Esposito, *Bios: Biopolitics and Philosophy* Chapter 5.

Crucially, our intellectual genealogy of the impolitical has led us to the same conception of Life that Painlevé's aesthetics led us to. Could it be that Life is the basis for a rapprochement between the political and the aesthetic? Such a tidy thesis would have to fend off a number of challenges, however. For instance, Cary Wolfe argues that Esposito endorses "a neovitalism that ends up radically dedifferentiating the field of 'the living' into a molecular wash of singularities that all equally manifest 'life'" (Wolfe 2012: 59), which is "unworkable both philosophically and pragmatically"(58). The real force of Wolfe's critique, I believe, is that a Life is incapable of delivering on what Esposito needs it to. More than anything, a Life needs to be an equalizing force that is capable of affirming all forms of life, and especially all those forms that were previously excluded (from humans to microbes). What this leads to is a form of ecological naïvite that rehearses all the problems of deep ecology (see Chapter 3). Referencing Timothy Lukes, Wolfe writes that "if all forms of life are given equal value, then we face questions such as the following: 'Will we allow anthrax or cholera microbes to attain self-realization in wiping out sheep herds or human kindergartens?'" (59). As an extension of this concern, I also worry that Esposito's neovitalism leaves little to no room for death. As any biologist will tell you, the difference between the life and death of an organism is hardly absolute. And furthermore, there are deaths that are inevitable and even important for the continuation of life.

Another worry that I have is that Esposito appropriates Deleuze's concept of a Life for ends that it wasn't meant for. For example, it's imperative for Esposito that there is no *zoe* (bare life) left outside of *bios* (political life): "anything that lives needs to be thought in the unity of life... every life is a form of life and every form refers to life" (Esposito 2008: 194). The problem is that a Life, in Deleuze's conception, is at the same time irreducible and indifferent to any form of life. Esposito makes the (common) mistake of thinking that a Life is generous and giving (I'm

tempted to say, the ultimate “gift”—see above), which bestows on his thesis an unmistakable theological significance. Or put another way, he makes the Kantian mistake of basing the transcendental on the empirical: that is, the transcendental’s legitimacy rests on its ability to include all forms of life within its scope.

But in fact, a Life cares little for the thriving of individual lives. This is why Deleuze and Guattari write that, “the organism is that which life sets against itself in order to limit itself” (Deleuze and Guattari 1987: 503). Organismic death is fully compatible with a Life in Deleuze and Deleuze/Guattari’s conception. The vital force of Life is the “Outside” to all individual purposes and strivings, including the ultimate purpose: self-preservation. What often goes unchecked about a Life is that it is not the basis for a new emancipatory politics of the individual (something that many cultural-studies appropriations have yet to fully acknowledge²²⁶); it may even appear dark and horrific, stripping the individual of all that’s meaningful to it, even its own life. Where Esposito turns Life into the basis for a political theology of inclusivity, a warm embrace that repopulates political thought with every form of life; Deleuze, on the other hand, seeks to depopulate thought, to evacuate thought of its pre-given forms, to eradicate all that is “already known.”

It should be acknowledged at this point that “depopulation” indexes Deleuze’s famous proclamation that “the people are missing” (Deleuze 1989: 126).²²⁷ And yet this sentiment should

²²⁶ This is in large part due to the over saturation of the work on “affect” in cultural studies, and the slow, if inaccurate, appropriation of Brian Massumi’s work on the concept in *Parables for the Virtual: Movement, Affect, Sensation*.

²²⁷ Phillip Thurtle has reminded me that in biology a population is not constituted by an individual or person per se—that is, a designated “what”—but by any group that shares a specified trait or circumstance. From this perspective, I think that population thinking coincides in important ways with what Whitehead means by a “society,” or a nexus of occasions of experience that share and self-reproduce a certain characteristic. Importantly, societies make up anything from rocks to humans to solar systems. But “Life,” in Whitehead’s conception, much as it is in Deleuze’s, is that which resists the route of societal inheritance; it is a “bit for freedom.” See Nocek, “Imaginative Chemistry: Synthetic Ecologies and the Construction of Life.”

not be read negatively, as if it were merely expressing the political pessimism of the day. Rather, it should be read through the lens of a Life: we have to invent “a people who are missing,” which is to say, a Life, so that we may forge the positive conditions for a “people to come.” As Gregory Flaxman has shown, the “becoming-imperceptible” that Deleuze celebrates in writers such as Franz Kafka, is really the basis for “a remarkable hospitality to populations with, through, and about whom one fabulates a new people...” (Flaxman 2012: 234). Radical deterritorialization forges a Life (or a plane of immanence) upon which a “new people” can be fabulated. “From depopulation, make a cosmic people,” write Deleuze and Guattari, and “from deterritorialization, a cosmic earth” (Deleuze and Guattari 1987: 346). A Life cannot be wielded in order to affirm a population already in place (Esposito), but it must be used to invent an impersonal space, an earth, for a new cosmic population. And it should come as no surprise that it is only through art that this depopulation is forged. Deleuze and Guattari continue:

the problem of the artist is that the modern depopulation results in an open earth, and by means of art, or by means to which art contributes. Instead of being bombarded from all sides by a limiting cosmos, the people and the earth must be like vectors of a cosmos that carries them off; then the cosmos will be art (ibid).

In discussing the conditions for such a “cosmic art,” Deleuze and Guattari rely heavily on minor literature, and Kafka in particular. Kafka’s work proposes a subject who is emptied out of its contents, by substituting the first person for the third person, which is the condition for “people to come.” How is this possible? Flaxman analyzes this question in terms of what the French linguist, Emile Benveniste, says about the syntax of the statement and how it conceals the logic of the subject. As opposed to the first and second person, which are always contained in the statement (“I” and “you” are always determined in the utterance), the third person, by contrast, is the one who is absent. This grammatical situation is perhaps most clearly illustrated in Arabic, “where

grammarians define the first person as ‘the one who speaks,’ the second person as ‘the one who is addressed,’ and the third person, most significantly, as the ‘one who is absent’” (Flaxman 2012: 231).

To assume the third person, as Kafka does in *The Castle*—beginning in the first person as K. and then rewriting early portions in the third person—is to become impersonal, to become the one who is “missing.” This pronominal shift is the condition for the writer to be emptied of contents, to deterritorialize and to inhabit the absence of the person so that he or she may accommodate others—the “people to come.” It is the basis for a new “image” of hospitality. Elsewhere, Deleuze explains that, “In each of us there is, as it were, an ascesis, in part turned against ourselves. We are deserts, but populated by tribes, flora and fauna... And all these clans,” he continues, “do not undermine the desert, which is our very ascesis. On the contrary, they inhabit it, they pass through it, over it” (Deleuze 2007: 11). We have to depopulate ourselves—to become deserts, an earth—in order for the tribes virtually within us to express themselves. This procedure may also be explained in terms of Deleuze and Guattari’s formula for how to make a rhizome in *A Thousand Plateaus*. There they explain that the overcoding dimension of language first needs to be subtracted out—“n-1”—before language can become multiple. The transcendent dimension has to be subtracted or emptied out, so that the (virtual) languages within language, the “flora and fauna” within us, can be expressed. It is only through subtraction that a Life for the new population can be forged.

The central provocation of this chapter is that Painlevé’s cinema invents just such a depopulated space, or a Life, within the biological population. It is in this way that the grammar of his cinema is comparable to Kafka’s prose. Painlevé’s tool kit is of course different than Kafka’s (in fact Deleuze is adamant in his cinema books that the image is not reducible to linguistic

analysis), but he uses the tools he has, namely, images (sometimes in extreme juxtaposition, sometimes non-figuratively, and sometimes in conjunction with witty commentary), to subtract our recognition, to eliminate our confidence that a given experience can be described in terms of an already extant conceptual scheme. His cinema empties out (n-1) the biological world of the knowing subject's secure foothold. Like Kafka, Painleve assumes the impersonality of the event, and literally lets the flora and fauna express themselves. By doing so, his art discovers a deterritorialized earth, a desert, or a non-organic life for the cosmic population that has yet to be invented.²²⁸

What this population looks like cannot be known in advance, though we know that its invention involves an incalculable risk. All those categories that were formerly used to secure our judgments about the “natural world” — morphology, speciation, population, habitat, genotype, phenotype, etc.— are no longer guarantees of anything. This is not to say that these categories no longer exist, it's to say that they no longer authorize our complete confidence.²²⁹ Their fixity has been wrought unstable by the Life that aesthetic contemplation discovers for the biological world. A population emptied of these categories, or at least evacuated of the confidence they authorize, is a population that remains virtually there, a *problem* that doesn't have a prescribed solution, and it is one that Painleve's art strives to unleash. In the end, such a politics of Life looks quite a bit different from Esposito's vital biopolitics: a Life affirms a population that *could* exit rather than the one that already exists.

²²⁸ In this way, the construction of a Life becomes a crucial site for political resistance, which Deleuze confirms for us in his book on Foucault. Resistance to power must come from the Outside, which he defines as life: “Life becomes resistance to power when power takes life as its object... When power becomes bio-power resistance becomes the power of life, a vital power that cannot be confined within species, environment or the paths of a particular diagram. Is not the force that comes from outside a certain idea of Life, a certain vitalism, in which Foucault's thought culminates?” (1988: 92-93).

²²⁹ Isabelle Stengers' work on an “ecology of practices” and “slow science” resonates deeply with what I'm suggesting here. See *Cosmopolitics Vols. 1&2* and “Another Science is Possible!: A Plea for Slow Science.”

By way of summary, Deleuze's reconceptualization of Kant's aesthetics has led us to appreciate how Painlevé's cinema enacts the aesthetic contemplation of living systems. As we know from Chapter 3, Painleve was no stranger to the techniques and methods used by the avant-garde: he dabbled freely with them; he associated with artists, and in general valued their company and trusted their opinions over other scientists. This is not to say that Painleve ever identified with them either— with the Surrealists, Dadaists, Cubists, etc.—although the latter freely appropriated his work. And furthermore, it's hard to say whether Painleve ever identified himself as an “artist” at all, if by that label he was forced to eliminate others, like “scientist.” I don't think Painleve would be comfortable with such labels.

But Painleve did produce art, or in any case, he achieved something like aesthetic contemplation in his underwater adventures. What our meditation on Kant and Deleuze exposes is the sense in which aesthetics is irreducible to rigid classification. With Kant's help, Deleuze aestheticizes ontology, makes aesthetics the transcendental condition for the genesis of the given. But this aesthetic genesis is precisely what gets overlooked in “common sense” and “good sense,” or the “dogmatic image” that conditions our everyday habits of thought. Painlevé's cinema exemplifies what Deleuze had in mind, I believe, when he spoke on many occasions of the “shock to thought” that would be capable of dislodging the firm grip of these well-worn habits. His work thus enacts the shock of aesthetic contemplation and unleashes a Life that tears through the anthropocentric net cast over living systems.

This perspective also recasts the politics of Painlevé's cinema in terms of “problematics” instead of “solutions.” Although releasing the firm grip of anthropocentrism may define the scope of his project, what form the population will take, remains unknown. Painleve is hospitable to an unknown guest. Our detour through Esposito's notion of the “impolitical” is instructive in this

regard since it provides a larger context for us to see how forging a non-anthropocentric Life for this population *is* the political conflict par excellence; it is that which is neutralized by the political— it’s the unthought, or impolitical, ground of the political. What careful attention to Deleuze and Guattari’s texts reveals, however, is that “who,” precisely, a Life is hospitable to must remain a problem without a final resolution. A Life is the earth, the desert, the non-organic life for the “tribes, flora and fauna” to populate, but the population that is invited to dwell there can never be known in advance. This is the point that Esposito misses. He marshals a Life to justify the lives that are already given, the ones that are already known (i.e., he uses the transcendental for the sake of the empirical), instead of imagining how a Life could become the basis for a population that has yet to be invented. Painlevé knows this, and is therefore adept at finding cinematic tools to uproot the confidence we have in our assumptions about living systems, and in so doing, he composes a Life for a population of “flora and fauna” whose definite form remains an open question.

Recall that what is at stake in our extended discussion of Painlevé —beginning in Chapter 3 and extending through our treatment of Kant and Deleuze in Chapter 4— is a genealogy of scientific visual aesthetics that does not fall prey to the logic of representation. What Chapter 2 plainly revealed for us, however, is that our genealogy will have to move outside of the annals of scientific imaging, precisely because the logic that guarantees the “scientific” status of image media is the logic that we are trying move beyond. It became clear then that micro- and nano-images are not subversive in the least, and only serve to demonstrate how ingrained representation truly is in

scientific imaging.

My hope is that Painlevé's work becomes a key moment in the history of scientific imaging, both because it broadens the archive of scientific visuality (to include artists on the fringes of science), and because it is illustrative of how visual media may be used to subvert pre-established norms in scientific epistemology. After all, it seems that this is what Daston and Galison were driving at all along: both photography and nanoimaging don't merely uphold the epistemic virtues of their day, but they transform them. What's so valuable about Daston and Galison's work is that it charts the techno-epistemic transformations that image media make possible.

Likewise, my argument is that the unacknowledged seeds of an alternative epistemology are in Painlevé's work, and that they are made possible by a visual aesthetics that strips human cognition of its capacity to represent. Of course, Daston and Galison are well aware of the danger that "aesthetics" signifies for scientific epistemology, and convincingly demonstrate how it is accommodated by the evolving conditions of scientific epistemology—until the nanoimage. But as we saw, Daston and Galison fail to realize that nanoaesthetics doesn't change the representational coordinates of epistemology at all, and in fact only serve to strengthen them under conditions of neoliberal capitalism.

This leads me to address one of the principle drawbacks of their work, which is that it treats nanoimaging as a mark of a "new" epistemic regime, one that is not beholden to the norms of representation. My worry is that they are blind to the fact that nonrepresentational scientific imaging has always been present—albeit on the margins—and that it does not index a new epistemic moment, or even worse, an "achievement." In this regard, I cannot state strongly enough how important Foucault's genealogy is for my work, since it showcases just how crucial "the accidents, the minute deviations—or conversely, the complete reversals—the errors, the false

appraisals, and the faulty calculations that give birth to those things which continue to exist or have value for us” (Foucault 1977: 146). Thus, representation and nonrepresentation do not exist in succession of one another; they co-exist, the one on the margins of the other. The existence of Painlevé’s cinema in the early twentieth century demonstrates this co-existence vividly for us: that there was a scientific aesthetics that could not be reconciled with representation, and for this reason was largely ignored by scientists. Thus, what Daston and Galison thought that nanoimaging was doing for epistemology in the 21st century, but ultimately could not, was already happening with the movie camera in the late 1920s. In short, genealogy stresses how representation is not the only norm possible for scientific epistemology, but the one that happened to win out due forces much wider than it. And as I showed in Chapter 1, the forces that tie visual science to the norms of representation in the twenty-first century are inextricably tied to neoliberal value production.

This brings me to the other blind spot in Daston and Galison’s work (mentioned above): namely, the inward-looking history of science that they offer. To fight the privilege of human representation in science (or anthropocentrism), is also, well and truly, a struggle against the modes of political and economic power that instill those values: industrial capitalism. To resist anthropocentrism cannot simply mean struggling against the technologies that facilitate it (e.g. the cinematic apparatus, and so on), though that may be an important part of it, but it also means resisting the wider forces of power that govern how technologies are deployed to promote anthropocentrism.

Unfortunately, the political-economic dimensions of the technological unfolding of scientific epistemology are largely overlooked by Daston and Galison. The risks of this oversight are many, but one risk is that their epistemological thesis is too tightly determined by technological advancements. Such view would turn a blind eye to Deleuze’s crucial insight in the “Postscript”

that “machines don't explain anything” (Deleuze 1995: 180). And while “it’s easy to set up a correspondence between any society and some kind of machine,” argues Deleuze, this “isn’t to say that their machines determine different kinds of society but that they express the social forms capable of producing them and making use of them” (ibid.). In other words, technical materials do not prescribe the kinds of societies, or “social machines,” that will use them; it is their organization, or their use, that expresses the dominance of a particular kind of societal power.²³⁰

Thus, through experimentation Painlevé discovers the means to resist not only the privilege of human representation in scientific cinema, but also, and more generally, the political and economic forces that perpetuate it. To say that Painlevé’s cinema is aesthetic, as I have been insisting on all along, is also to say that his cinema invents an Outside for scientific epistemology, an Outside that responds to what threatened to overwhelm it. He finds an interstice within the closed circuit of the human comprehension of nature fueled by bourgeois capitalism, and opens it up to a transcendental Outside, a Life that is hospitable to future inhabitants who cannot be known in advance. This is a politics of Nature, or “Nature Politics,” that interrupts the anthropocentric projection of thought onto it, where thought always knows in advance to whom it is being hospitable: itself. And where this pathological form of hospitality is the ultimate triumph of bourgeois values— Nature in service of human values— Painlevé’s Nature Politics is one that struggles against this closed circuit by keeping Nature’s determinacy problematic.

²³⁰ Thomas Lamarre does a wonderful job of explaining this in his 2009 work, *The Anime Machine: A Media Theory of Animation*.

Conclusion: Molecular Aesthetics

By way of conclusion, I'd like to return to some key insights that Janet Iwasa, from the Department of Cell Biology at Harvard Medical School, makes about the significance of computer animation in cell biology. I want to use this as a starting point to lure us into final reflections about the aesthetic genealogy I've just traced, and its relevancy for molecular animation today. In her article, "Animating the Model Figure," Iwasa explains that

[e]ven in cases where little is known about a molecular process, creating a dynamic 3D model, especially one that can be modified in a reiterative manner as new information is gained, can lead to important insights that would be hard to achieve by other means. It is important to note that these animations are not necessarily meant to act as a consensus model to depict a mechanism that has received a stamp of approval by a majority of others in the field, or even by others in a research group. Rather, these visualizations are intended to show an individual's hypothesis of how a process might occur. This hypothesis can include aspects that are not yet supported by experimentation, and the visualization can act as a thinking and communication tool that might give insight into how this hypothesis would best be explored and tested experimentally (Iwasa 2010: 700).

Iwasa then acknowledges that many scientists are skeptical about the technology because it provides a "hypothetical model," instead of an accurate depiction of what is experimentally known. As we saw in Chapter 1, this is no different from the complaints that scientists often level against the hypothetical or fantastical character of 2D and 3D models.²³¹ And, yet, Iwasa does not back down from these criticisms; rather, she sees the hypothetical, or "as if," character of animation to be one of its principle virtues. That the spatiotemporal dynamics of molecular and cellular structures are "added on" to what scientists already agree on is not a problem for Iwasa, but it is an opportunity. In other words, where many scientists distrust models that do not reflect what is already known about the world, with computer animation Iwasa sees a unique occasion for modeling to drive thinking in new directions, instead of communicating an agreed upon fact.

²³¹ See especially Sherry Turkle's work, *Simulation and its Discontents*.

Much of what is compelling about Iwasa's argument, and is in some ways distinct from what her animation colleagues contend (see Chapter 1), is that animation is not primarily about representation, or at least in principle. She does not feel compelled, in other words, to provide ad hoc justifications for how animation represents spatial and temporal dynamics of molecules better than other visualization technologies (see Krichhausen). How, for example, large sets of data are translated into spatial and temporal form is not an agreed upon fact; but this is precisely why the technology is exciting: it is a digital platform for experimentation and fictional world building. In her article, she offers some compelling examples of how this works.

She contends, for instance, that motor proteins, which transport proteins and vesicles in the cytoplasm, are a particularly difficult class of molecules to get a handle on, since understanding the mechanism of their movement depends upon understanding their spatial and temporal dynamics. She explains that while scientists have gained a significant amount of information about the structure and movement of dynein, a motor protein that transports “cargo” (*sic*) along microtubules in the cytoplasm, “the mechanism by which dynein is capable of walking processively along microtubules remains an area of active investigation” (Iwasa 2010: 702). With Reck-Peterson group at Harvard Medical School, Iwasa built a manipulatable 3D animation of dynein to investigate this process. Securing data from a variety of sources,²³² the animation offers multiple possibilities for manipulating the protein, and thus investigating its various potentials for movement. What's especially intriguing about Iwasa's model is that she built multiple versions of it. The first animation was deemed too technical, and thus misleading since viewers may have believed that model was based upon “actual” structural data. A second model was then built, which

²³² “The microtubule-binding domain is from a published crystal structure, the AAA domain and coiled-coil region are derived from crystal structures of homologous structures, and the linker domain is a simple flexible cylinder whose length is approximated from estimates taken from EM studies” (Iwasa 2010: 702).

displayed “softer, smooth surfaces” in order to flag its “hypothetical” character (ibid). As she put it, the model was then able to effectively help researchers in “formulating and visualizing different hypotheses” (701), and in particular, it “has been instructive in revealing the conformations of dynein that are possible or impossible given structural and steric constraints” (702).

What’s intriguing here is how important the exaggeration of visual form is to freeing animation up for its unique role in scientific research: namely, to *propose* different ways of linking data. In other words, an animation that contains too much detail about molecular surfaces generates the expectation among scientists that it competes with a class of models—e.g., crystallography—that it is not meant to. Audiences judge the model, as with every other kind of model, for its representational accuracy, instead of its capacity for generating possibilities. In this perspective, the fact that scientific animators are using highly stylized graphics from Hollywood animation studios may not be detrimental at all; rather, it may even enable animation to secure a foothold in scientific epistemology. To begin to characterize this unique foothold would require acknowledging that animation forges possibilities for scientific thought that are not yet confirmed. It builds relationships between elements that are not “verified,” and indeed, may never be verified. In this way, the technology proposes *a way* of interpreting the world, which may build on what is given in the data, but is not prescribed by it.

Alfred North Whitehead speaks of “propositions” in a way that resonates with what I’m suggesting about molecular animations. For Whitehead, propositions designate a category of objects or entities that put data into a potential relation for subjects to entertain (or to “feel” in Whitehead’s technical vocabulary). As he puts it in his 1927-28 Gifford Lectures published as *Process and Reality*, the proposition is neither “true” nor “false” in itself. Rather than treat propositions as “materials for judgment,” as he had in his co-authored work with Bertrand

Russell,²³³ Whitehead now contends that propositions are fully real, hybrid entities that are among the “eight categories of existence,” irrespective of their “truth value.” “Its own truth, or its own falsity, is no business of a proposition,” Whitehead claims. “That question,” he continues, “concerns only a subject entertaining a propositional feeling” (Whitehead 1978: 258). Propositions open up alternative ways of feeling the world instead of merely reflecting upon or representing it.

Whitehead contends that “propositions” are what “lure us into feeling” a world that “might be” by placing a subject (data) into a possible relation with a predicate. Again, this relation need not conform to the conditions of the actual world, and so may end up being false. But even when the proposition turns out to be “non-conformal” to the actual world, it does not mean that the feeling is “merely wrong, and therefore worse than useless” (1978: 178). In *Symbolism: Its Meaning and Effect* Whitehead contends that “[i]n the initial stages of mental progress, error...is the discipline which promotes imaginative freedom” (Whitehead 1985: 19). This is perhaps why he claims in *Process and Reality* that “it is more important that a proposition be interesting than that it be true” (Whitehead 1978: 259).

In many ways Whitehead’s concept of the proposition provides a new layer of theoretical robustness to our account of what animations can offer researchers. Indeed, the “truth” (as correspondence) of animation is not what is at stake per se; instead, what’s at stake is the technology’s capacity for putting scientific data, or what is already agreed upon, into a potential relations with a set of predicates: namely, space and time. Space and time do not belong to the data by right—which is to say, their relation to molecular data has not been scientifically verified—and

²³³ See George R. Lucas, Jr., *The Rehabilitation of Whitehead: An Analytic and Historical Assessment of Process Philosophy*, for an illuminating account of Whitehead’s metaphysical theory of the proposition in relation to the two-value logic that he maintains in the *Principia* (Lucas 1989: 141-142).

animation is unique insofar as it *proposes* different ways of folding spatiotemporal dynamics into molecular data.

One of my central provocations of this concluding chapter is that molecular animations have the capacity to become propositional media (instead of representational media) that lure scientific thought into different ways of entertaining the molecular world. I think Iwasa's insights testify to this possibility. I also think that considering molecular animation as a form propositional media is what makes it the unacknowledged successor to Painleve's scientific aesthetics. Like Painleve, animations are at once rooted in what is already known about natural processes, and, simultaneously, they are generators of relations for those processes that do not conform to a pre-conceived notions, or a priori categories. In other words, animations very often force their audiences into the position of a Whiteheadian subject who must entertain a set of relations that are non-conformal to what is known about the molecular world. Space and time become predicates that are folded into models that render molecular data scientifically unrecognizable; and this is precisely what makes many scientists uncomfortable. As I have shown throughout this dissertation, the aesthetic has made scientists uncomfortable for centuries, and the aesthetic potential of animation is no different. Computer animation, for scientists like Tomas Kirchhausen, is a cartoon-like fantasy instead of useful molecular visualization. To open molecular data up to spatial and temporal relations that are hypothetical is not only propositional, then, but it is also aesthetic. It is for this reason that molecular animation, I want to suggest, can be the inheritor of Painlevé's visual aesthetics.

With a great deal of help from Daston and Galison, I have shown that nonrepresentational aesthetics do not sit comfortably within scientific epistemology: time and again, the "aesthetic" has found a way to facilitate representation instead of challenging it. This is as true of

microcinematography as it is of nanotechnology. What Daston and Galison propose, however, is that with the advent of nanoinaging and digital atlases more generally, a new era of nonrepresentational scientific visuality is ushered in. And, yet, don't I seem to be saying the same thing about computer animation? That is, it too is a nonrepresentational and therefore aesthetic medium for conducting scientific research? There is one essential difference, however: While my suggestion is that computer animation (and nanoimaging for that matter) has the *potential* to function nonrepresentationally, I do not believe that it *actually* does.

Just as representation was able to accommodate the “aesthetic” interventions of the cinematograph in the early twentieth century, as well as the nano-technical creations in the twenty-first century, so, too, representation is able absorb the animate proposals qua propositions of molecular and cellular biology. As I have tried to show throughout this dissertation, representation is not an isolated moment in scientific epistemology in the West. Deleuze is acutely aware of this fact, which is one of the reasons that he is drawn on so frequently in this research. Rather, representation is the backdrop for the evolving epistemic “virtues” in scientific epistemology. But if Daston and Galison's inability to appreciate this fact has emerged like a chorus line for my study, then this needs to be tempered by how important their work truly is for me. For them, representation is a silent, but ever-present assumption for scientific visual culture; but it is an assumption that is ultimately overturned, according to them, with the advent of digital and nano culture.

The premise of my work is representation is overturned via new technologies is fundamentally naïve. But it is a naïvete that stems, I believe, from methodological constraints more generally. As I underscored in Chapter 1, their inward-looking history of scientific epistemology blinds them from seeing how the evolution of representation in the sciences is inextricably tied to

the evolving circuits of political and economic power. While they do a good job of charting how objectivity, and other epistemic virtues, fits into a “moral economy,” they make no effort to place this moral economy into specific circuits of political and economic power. Deleuze’s work on control societies and Galloway’s work on digital networks brought into full view how the neoliberalization of cybernetic science is still bound to a logic of representation (which is as true in nanoimaging as it is in molecular animation). By drawing on Deleuze’s earlier studies of biology and cinema, we were able to see how molecular animation is in fact exemplary for the way in which it promotes representation by internalizing competition and championing it as the new law that needs expression. Where representation may appear to be overcome, or in any case set aside, from an internalist perspective, from the perspective of the evolving conditions of political and economic power, it is may be more pervasive now than ever before.

If we return to Iwasa and the propositional potential of molecular animation, we realize very quickly that this is itself a proposition. While it is indeed true that computer animations are proposals that (ideally) lure scientists into building previously unacknowledged relationships between data sets, in practice, the “world building” that occurs there is inseparable from the kinds of worlds that are deemed worthy of building. And those worlds, as I took pains to emphasize in Chapters 1 and 2, presuppose the validity of the laws of the market. The values of competition and flexibility, in short neoliberal values, are what validate the choice to entertain an animation, and also to disqualify those that do not meet such criteria.

At this point, the benefits of a media archeological perspective on molecular animation should be clear. There is no single history to computer animation. Where media scholars tend to trace its origins back to flipbooks, story scrolls, and even puppetry, this study has excavated two different, if often overlooked, histories of the technology; and they are histories that include a very

different set of technologies and values than we encounter in typical media histories of animation. Using this methodology, we have also come to appreciate the dominance of representational values in the history scientific visual culture, as well as how those values are governed by various circuits of political and economic power. Thus, the aesthetic history that I'm suggesting for molecular animation is a part of a history that is not readily accepted, or even acknowledged until now.

Promoting this genealogy would require an overhaul of the culture of scientific animation. Iwasa herself notes (although accompanied by very little reflection) that one of the serious limitations of using 3D animations in scientific research is the exclusivity of the technology. For example, she bemoans that her dynein model is only available on commercial animation software (Maya Autodesk), and, unfortunately, there is a steep learning curve involved in using this software. Indeed, this seems to be a generally agreed upon fact in molecular visualization communities, a point that was expressed at the "Molecular Animation Workshop" in 2010 hosted by the Resource for Biocomputing, Visualization and Informatics (RBVI) and the National Center for Macromolecular Imaging (NCMI).²³⁴As a result, only those scientists who have time and money to invest in learning and using the software are interested in exploring its many potentials. As a consequence, the scientist-animator has also become a scientist-entrepreneur devising new investment opportunities for data visualization. Gaël McGill, one of the premiere scientist-animators, is now president and CEO of Digizyme, INC, a company that "innovate[s] at the intersection of science, technology, art and learning to create accurate and effective visual context for understanding science," by combining "graduate-level training in the life sciences with industry-leading skills in animation, experience design and software development" (<http://www.digizyme.com/index.html>). Likewise, Jason Sharpe, who coauthored the most

²³⁴ <http://www.ncbi.nlm.nih.gov/pmc/articles/PMC3071847/>

extensive textbook in the field of molecular animation, is president and founder of AXS Studio, a “life sciences visual communications company,” whose client base comes from “pharmaceutical, biotechnology and medical device companies” (<http://axs3d.com/index.php>). In other words, the most powerful voices in the field come from industry. Combine this industry-intensive work with Graham Johnson’s push to automate the image-generation process (see Chapter 1), Deleuze’s worst fears about the conjunction of biology and the image in cybernetic science seem to have come true.

Isabelle Stengers has recently spoken out against the dominance of industrial values in contemporary technoscience.²³⁵ While the tight connection between scientific and political and economic values is far from a new topic in science-studies research, what interests Stengers, and indeed sheds new light on the topic, are the lengths that ostensibly academic science will go to protecting the values of industry. In her view, the cost of protecting industry at the expense of all else—even sacking those, like Barbara van Dyck, a scientist at The *Katholieke Universiteit Leuven*, who objected to GMO research and development in their free time²³⁶—are profound: it risks scientific reliability as such, which depends upon competent specialists, from different expertise, submitting scientific claims to rigorous objections. Unfortunately, these objectors no longer exist, she contends, since the interests of scientists are, by and large, already “settled interests.”

I have written on this in a forthcoming article,²³⁷ and argue there that those who object to the settled interests of industry must seem like Idiots. I do not use Idiot in a pejorative sense,

²³⁵ See Isabelle Stengers, “A Plea for Slow Science: Another Science is Possible.”

²³⁶ Barbara van Dyck was sacked from K.U. Leuven for speaking out against GMOs in Wetteren farmlands. Stengers writes about this incident in her article, “A Plea for Slow Science: Another Science is Possible.” Also see: <http://gmwatch.eu/latest-listing/1-news-items/13218-researcher-sacked-others-threatened-over-gm-protest>

²³⁷ See A.J. Nocek, “On Symbols, Propositions, and Idiocies: Toward a Slow Technoscience” (forthcoming).

however, but invoke it in the way that Deleuze does in *Difference and Repetition* to praise Idiocy in “the Russian manner” (Deleuze 1994: 130). In Deleuze’s view, the Idiot in Dostoyevsky’s *Notes from the Underground* protests “what everybody knows,” that is to say, what passes for “common sense.” The “underground man,” Deleuze explains, “recognizes himself no more in the subjective presuppositions of a natural capacity for thought than in the objective presuppositions of a culture of the times, and lacks the compass with which to make a circle” (ibid.). Similarly, for Stengers the Idiot “is the one who always slows the others down, who resists the consensual way in which the situation is presented and in which emergencies mobilize thought or action” (Stengers 2004: 2). Furthermore, “the idiot demands that we slow down, that we don’t consider ourselves authorized to believe we possess the meaning of what we know” (ibid.). For Deleuze, as for Stengers, Idiocy refuses to authorize a hidden source of knowledge that transcends the situation; it resists the temptation to place faith in an arbiter who can validate and disqualify others’ claims. The Russian Idiot approaches a situation without presumption—or a pre-given “image of thought”—and thus possesses no mastery over the rules that govern it.²³⁸

Stengers explains that it is Deleuze’s Idiot persona, and not Kant’s “citizen of the cosmos,” that is behind her cosmopolitical proposal in her multivolume *Cosmopolitique*. Indeed, that her cosmopolitics might to be confused with Kantian cosmopolitanism, a state of affairs in which everyone might be a member of a world citizenry, a “citizen of the cosmos,” worries Stengers: “This is where the proposal is open to misunderstanding,” she writes, and is susceptible to being interpreted as a politics that “aim[s] at allowing a ‘cosmos’, a ‘good common world’ to exist—while the idea is precisely to slow down the construction of this common world, to create a space for hesitation regarding what it means to say ‘good’” (2004: 3). The cosmopolitical refuses to give

²³⁸ See Deleuze, *Difference and Repetition*, Chapter 3.

a definition of what is held in common and by whom. On the contrary, it calls upon us to abstain from answering on behalf of others and knowing in advance who those others will be. This is why “[t]he cosmos” she continues,

must therefore be distinguished here from any particular cosmos, or world, as a particular tradition may conceive of it. Nor does it refer to a project designed to encompass them all...In the term cosmopolitical, cosmos refers to the unknown constituted by these multiple, divergent worlds, and to the articulations of which they could eventually be capable, as opposed to the temptation of a peace intended to be final, ecumenical: a transcendent peace with the power to ask anything that diverges to recognize itself as a purely individual expression of what constitutes the point of convergence of all (4).

In this perspective, there is a very particular neoliberalized cosmos that determines what’s acceptable for computer animation in the sciences. To use animation propositionally, as Iwasa seems to propose, and thus inherit the aesthetics that Painlevé forged decades ago, is to risk being an Idiot. It is to use the technology in a way that does not appeal to a value, or cosmos, that is held in common. Painlevé refused to accept what “everyone knows,” namely, anthropocentrism, and sought ways resist its firm grip. What this cost him, however, was scientific credibility. Scientific animation faces a similar challenge today. To use the technology to build worlds that refuse to presuppose neoliberal values, and thus entertain predicative patterns that are not prescribed, falls outside of the orbit of scientific acceptability in the twenty-first century. These animations would be truly Idiotic insofar as their hospitality would extend to biological worlds that are not yet known; and neoliberal hospitality extends only to those worlds that are competitive in the market. The connections between Painlevé’s biopolitical cinema and the political potentials of molecular animation are sharpened at this point: both are hospitable to forms of life whose coordinates are not known in advance. It is also unknown at this point how much the cosmopolitical would help conceptualize what this hospitality means politically for scientific animation, but I want to leave this as lure for future research.

What does seem more certain, however, is that “aesthetics,” “propositions,” and “Idiocies” converge in this new genealogy of molecular animation. And, yet, they are each ways of interacting with technology (or “collective assemblages” to which the technology belongs), I want to insist, that open onto distinct intellectual genealogies. But to the extent that these genealogies coalesce in animation, is also the extent to which they remain virtual potentials of molecular animation. Although Painlevé’s cinema was actualized, it is important to recall what André Bazin notes: namely, it was too scientific to be art and too artistic to be science. Painlevé’s work is incapable of lurking anywhere but in the shadows. And were molecular animation to actualize the virtual tendencies that it shares with Painleve’s work, it too, I imagine, would be disqualified and fated to lurk in the shadows of science. Until that time, it remains propositional lure for us to entertain—it is a lure for a new past just as much as it is a lure for a new future.

Bibliography

- Alliez, Eric. *The Signature of the World: What is Deleuze and Guattari's Philosophy?*. (Eliot Ross Albert and Alberto Toscano Trans.). London and New York: Continuum, 2005
- Andrew, Dudley. *What Cinema Is!*. Malden, MA: Wiley-Blackwell, 2010.
- Azuma, Hiroki. *Otaku: Japan's Database Animals*. (Jonathan E. Abel and Shion Kono Trans.). Minneapolis: University of Minnesota Press, 2009.
- Balazs, Bela. *Theory of the Film: Character and Growth of a New Art*. (Edith Bone, Trans.). New York: Dover, 1970.
- Barreiro, Olga, Francisco Sánchez-Madrid. "Molecular Basis of Leukocyte-Endothelium Interactions During the Inflammatory Response." In *Revista Española de Cardiología* 62, no. 5 (2009).
- Bazin, Andre. "Accidental Beauty." *Science is Fiction: The Films of Jean Painlevé*. (Jeanine Herman, Trans.). Cambridge, MA: The MIT Press.
- Bedau, Mark. "Artificial Life." *Handbook of the Philosophy of Science. Volume 3: Philosophy of Biology*. Mohan Matthen and Christopher Stephens (eds.). Amsterdam and Oxford: Elsevier, 2007.
- Bedau, Mark. "Weak Emergence." *Philosophical Perspectives: Mind, Causation, and World, vol. 11*. J. Tomberlin (ed.). Malden, MA: Blackwell, 1997.
- Beckman, Karen. *Animating Film Theory* (ed.). Durham, NC: Duke University Press, 2014.
- Bell, Jeffrey A. *Deleuze's Hume: Philosophy, Culture and the Scottish Enlightenment*. Edinburgh: Edinburgh University Press, 2009.
- Beller, Jonathan. *The Cinematic Mode of Production: Attention Economy and the Society of the Spectacle*. Hanover, NH: Dartmouth College Press, 2006.
- Bennett, Jane. *Vibrant Matter: A Political Ecology of Things*. Durham, NC: Duke University Press, 2009.
- Berardi, Franco. *After the Future*. (Nicholas Thoburn, Trans.). Oakland and Edinburgh: AK Press, 2011.
- Berardi, Franco. *The Soul at Work: From Alienation to Autonomy* (Francesca Cadel and Giuseppina Mecchia, Trans.). Los Angeles: Semiotext(e), 2009.
- Berardi, Franco. *The Uprising: On Poetry and Finance*. Los Angeles: Semiotext(e), 2012.
- Berg, Brigitte. "Contradictory Forces: Jean Painlevé, 1902-1989." *Science is Fiction: The Films of Jean Painlevé*. (Jeanine Herman, Trans.). Cambridge, MA: The MIT Press.

- Bolton, Christopher, Istvan Csicsery-Ronay Jr., and Takayuki Tatsumi (eds.). *Robot Ghosts and Wired Dreams: Japanese Science Fiction from Origins to Anime*. Minneapolis: University of Minnesota Press, 2007.
- Braidotti, Rosi. *The Posthuman*. Cambridge, UK: Polity, 2013.
- Brenner, Neil (ed.). *Implosions/Explosions: Towards a Theory of Planetary Urbanization*. Berlin: Jovis, 2014.
- Brown, Nathan. "Needle on the Real: Technoscience and Poetry at the Limits of Fabrication." *Nanoculture: Implications of the New Technoscience*. Hayles, N. Katherine (ed.). Portland, OR: Intellect Books, 2004.
- Brown, Wendy. "Neo-liberalism and the End of Liberal Democracy." *Theory & Event* 7, no. 1 (2003).
- Bryant, Levi. *The Democracy of Objects*. Ann Arbor: Open Humanities Press, 2011.
- Bryant, Levi. *Onto-Cartography: An Ontology of Machines and Media*. Edinburgh: Edinburgh University Press, 2014.
- Buchan, Suzanne. Editorial in *Animation: an Interdisciplinary Journal* 1 no 2 (2006).
- Buchan, Suzanne (ed.). *Pervasive Animation*. New York: Routledge, 2013.
- Buchan, Suzanne. *The Quay Brothers: Into a Metaphysical Playroom*. Minneapolis: University of Minnesota Press, 2010.
- Burger, Peter. *Theory of the Avant-Garde* (Michael Shaw, Trans.). Minneapolis: University of Minnesota Press, 1984.
- Cahill, James Leo. "Anthropomorphism and its Vicissitudes: Reflections on *Homme-sick* Cinema." *Screening Nature: Cinema Beyond the Human*. Anat Pick and Guinevere Narraway (eds.). New York and Oxford: Berghahn Books, 2013.
- Campbell, Timothy. "Genres of the Political: The Impolitical Comedy of Conflict." In the proceedings for the *Society for the Study of Bio-political Futures*, 2013: <http://www.biopoliticalfutures.net/ssbf-events/ssbf-syracuse-2>
- Canguilhem, Georges. "The Concept of Life." *A Vital Rationalist*. (Arthur Goldhammer, Trans.). New York: Zone, 2000.
- Canguilhem, Georges. "The Epistemology of Biology." *A Vital Rationalist*. (Arthur Goldhammer, Trans.). New York: Zone, 2000.
- Canguilhem, Georges. "The Question of Normality in the History of Biological Thought." *Ideology and Rationality in the Life Sciences*. (Arthur Goldhammer, Trans.). Cambridge, MA: The MIT Press, 1988.

- Cardinal, Roger. "Andre Breton and the Automatic Message." *André Breton: The Power of Language*. Ramona Fotiade (ed.). Chicago: University of Chicago Press, 1999.
- Carrel, Alexis. "The New Cytology." *Science* 20 (1931).
- Carrel, Alexis. "Physiological Time." *Science* 18 (1931).
- Cartwright, Lisa. *Screening the Body: Tracing Medicine's Visual Culture*. Minneapolis: University of Minnesota Press, 1995.
- Cavell, Stanley. *The World Viewed: Reflections on the Ontology of Film*. Cambridge, MA: Harvard University Press, 1979.
- Chomsky, Noam. *Profit Over People: Neoliberalism and the Global Order*. New York, Seven Stories Press, 1999.
- Connolly, William E. *Neuropolitics: Thinking, Culture, Speed*. Minneapolis, MN: University of Minnesota Press, 2002.
- Cooper, Melinda. *Life as Surplus: Biotechnology and Capitalism in the Neoliberal Era*. Seattle: University of Washington Press, 2008.
- Coopmans, Catelijne, Janet Vertesi, Michael Lynch, and Steve Woolgar, eds. *Representation in Scientific Practice Revisited*. MIT Press, 2014.
- Crary, Jonathan. *24/7: Late Capitalism and the Ends of Sleep*. New York: Verso, 2013.
- Cubitt, Sean. *The Practice of Light: A Genealogy of Visual Technologies from Prints to Pixels*. Cambridge, MA: The MIT Press, 2014.
- Dali, Salvador. *Oui: The Paranoid Critical Revolution, Writings 1927-1933*. (Yvonne Shafir, Trans.) Boston: Exact Change, 1998.
- Daston, Lorraine, and Peter Galison. *Objectivity*. New York: Zone Books, 2007.
- Doyle, Richard. *On Beyond Living: Rhetorical Transformations in the Life Sciences*. Stanford: Stanford University Press, 1997.
- Susanne Deicher, *Piet Mondrian, 1872–1944: Structures in Space*. Cologne: Taschen, 1995.
- DeLanda, Manuel. *Intensive Science and Virtual Philosophy*. London and New York: Continuum, 2005.
- Deleuze, Gilles, and Félix Guattari. *Anti-Oedipus: Capitalism and Schizophrenia*. (Robert Hurley, Mark Seem, Helen R. Lane, Trans.). Minneapolis, MN: University of Minnesota Press, 1983.
- Deleuze, Gilles, and Félix Guattari. *A Thousand Plateaus: Capitalism and Schizophrenia*. (Brian Massumi, Trans.). Minneapolis, MN: University of Minnesota Press, 1987.

- Deleuze, Gilles, and Félix Guattari. *Kafka: Toward a Minor Literature*. (Dana Polan, Trans.). Minneapolis, MN: University of Minnesota Press, 1986.
- Deleuze, Gilles, and Félix Guattari. *What is Philosophy?* (Hugh Tomlinson and Graham Burchell, Trans.). New York: Columbia University Press, 1994.
- Deleuze, Gilles. *Bergsonism*. (Hugh Tomlinson and Barbara Habberjam, Trans.). New York: Zone Books, 1988.
- Deleuze, Gilles. *Foucault*. (Seán Hand, Trans.). Minneapolis, MN: University of Minnesota Press, 1988.
- Deleuze, Gilles. *Cinema 1: The Movement-Image*. (Hugh Tomlinson and Barbara Habberjam, Trans.). London: Athlone, 1986.
- Deleuze, Gilles. *Cinema 2: The Time-Image*. (Hugh Tomlinson and Robert Galeta, Trans.). London: Athlone, 1989.
- Deleuze, Gilles. "Conversation with Toni Negri." (Martin Joughin, Trans.). *Futur Antérieur* 1 (1990).
- Deleuze, Gilles, and Claire Parnet. *Dialogues II*. (Hugh Tomlinson and Barbara Habberjam, Trans.). New York: Columbia University Press, 2007.
- Deleuze, Gilles. *Difference and Repetition*. (Paul Patton, Trans.). New York: Columbia University Press, 1994.
- Deleuze, Gilles. *The Fold: Leibniz and the Baroque*. (Tom Conley, Trans.). Minneapolis, MN: University of Minnesota Press, 1993.
- Deleuze, Gilles. *Francis Bacon: The Logic of Sensation*. (Daniel W. Smith, Trans.). Minneapolis, MN: University of Minnesota Press, 2004.
- Deleuze, Gilles. "Immanence: A Life." *Pure Immanence: Essays on A Life*. (Trans. Anne Boyman, Trans.). New York: Zone Books, 2005.
- Deleuze, Gilles. *Kant's Critical Philosophy: The Doctrine of the Faculties*. (H.R.E. Tomlinson and Barbara Habberjam, Trans.). London and New York: Continuum, 2008.
- Deleuze, Gilles. *The Logic of Sense*. (Mark Lester, Trans.). New York: Columbia University Press, 1990.
- Deleuze, Gilles. "Postscript on the Societies of Control." *Negotiations: 1972-1990*. (Martin Joughin, Trans.). New York: Columbia University Press, 1995.
- Dostoyevsky, Fyodor. *Notes from the Underground*. (Richard Pevear and Larissa Volokhonsky, Trans.). New York: Everyman's Library, 2004.

- Drexler, K. Eric. *Engines of Creation: The Coming Era of Nanotechnology*. New York: Anchor Books, 1986.
- Drexler, K. Eric. *Nanosystems: Molecular Machinery, Manufacturing, and Computation*. New Jersey: John Wiley and Sons Inc., 1992.
- Drexler, K. Eric, Chris Peterson, Gayle Pergamit. *Unbounding the Future: The Nanotechnology Revolution*. New York: William Morrow and Company, Inc., 1993.
- Dulac, Germaine. "The Essence of the Cinema: The Visual Idea." (Robert Lamberton, Trans.). In *The Avant-Garde Film: A Reader of Theory and Criticism*. P. Adams Sitney (ed.). New York: New York University Press, 1978.
- Eisenstein, Sergei. "The Cinematographic Principle and the Ideogram." *Film Form: Essays in Film Theory*. (Jay Leyda, Trans.). New York: Hartcourt, 1977.
- Eisenstein, Sergei. *Eisenstein on Disney*. (Alan Upchurch, Trans.). London: Methuen, 1988.
- Eribon, Didier. "Le 'Je Me Souviens' De Gilles Deleuze." *Entretien. Le Nouvel Observateur*, 1995, 16-22.
- Esposito, Roberto. *Bios: Biopolitics and Philosophy*. (Timothy Campbell, Trans.). Minneapolis: University of Minnesota Press, 2008.
- Esposito, Roberto. *Communitas: The Origin and Destiny of Community*. (Timothy Campbell, Trans.). Stanford: Stanford University Press, 2009.
- Esposito, Roberto. *Dieci Pensieri sulla politica*. Bologna: Il Mulino, 1993; 2010.
- Esposito, Roberto. *Immunitas: The Protection and Negation of Life*. (Zakiya Hanafi, Trans.). Cambridge, UK: Polity, 2011.
- Esposito, Roberto. *Ordine e conflitto. Machiavelli e la letteratura politica del Rinascimento italiano*. Naples: Liguori, 1984.
- Finkelstein, Haim. *Salvador Dali's Art and Writing, 1927-1942: The Metamorphosis of Narcissus*. Cambridge, UK: Cambridge University Press, 1998.
- Fisher, Mark. *Capitalist Realism: Is There No Alternative?* Winchester: Zero Books, 2009.
- Fisher, Mark. *Ghosts of My Life: Writings on Depression, Hauntology and Lost Futures*. Winchester: Zero Books, 2014.
- Flaxman, Gregory. *Gilles Deleuze and the Fabulation of Philosophy: Powers of the False, vol. 1*. Minneapolis: University of Minnesota Press, 2011.
- Foucault, Michel. *The Archeology of Knowledge: And The Discourse on Language*. (AM Sheridan Smith, Trans.). New York: Pantheon Books, 1972.

- Foucault, Michel. *The Birth of Biopolitics: Lectures at the Collège De France, 1978-79*. (Graham Burchell, Trans.). Basingstoke: Palgrave Macmillan, 2008.
- Foucault, Michel. *The Birth of the Clinic: An Archaeology of Medical Perception*. (Alan Sheridan, Trans.). New York: Vintage, 1994.
- Foucault, Michel. *Discipline and Punish*. (Alan Sheridan, Trans.). London: Penguin, 1991.
- Foucault, Michel. *The History of Sexuality, vol. 1*. (Robert Hurley, Trans.). New York: Random House, 1978.
- Foucault, Michel. "Nietzsche, Genealogy, History." *Language, Counter-Memory, Practice: Selected Essays and Interviews*, by D.F. Bouchard. Ithaca: Cornell University Press, 1977.
- Foucault, Michel. *The Order of Things: An Archaeology of the Human Sciences*. New York: Vintage, 1994.
- Foucault, Michel. *Security, Territory, Population: Lectures at the Collège De France, 1977-78*. (Graham Burchell, Trans.). Basingstoke: Palgrave Macmillan, 2007.
- Foucault, Michel. *Society Must Be Defended: Lectures at the Collège De France, 1975-76*. (David Macey, Trans.). New York: Picador, 2003.
- Frichot, Hélène, and Stephen Loo. *Deleuze and Architecture*. Edinburgh: Edinburgh University Press, 2013.
- Friedman, Milton. *Capitalism and Freedom*. Chicago: University of Chicago Press, 1982.
- Fry, Ben. *Visualizing Data*. Beijing: O'Reilly Media, 2008.
- Galloway, Alexander R. "Computers and the Superfold." *Deleuze Studies* 6, no. 4 (2012): 513-28. doi:10.3366/dls.2012.0080.
- Galloway, Alexander R. *The Interface Effect*. Cambridge, UK: Polity, 2012.
- Galloway, Alexander R. *Protocol: How Control Exists after Decentralization*. Cambridge, MA: MIT Press, 2004.
- Gaskill, Nicholas, A.J. Nocek. "Introduction: An Adventure of Thought." *The Lure of Whitehead*, by Nicholas Gaskill and AJ Nocek. Minneapolis, MN: Minnesota University Press, 2014.
- Gay, Peter. *The Bourgeois Experience: Victoria to Freud*, volume 1: *Education of the Senses*. Oxford: Oxford University Press, 1984.
- Grasso, P. et al. *Essentials of Pathology for Toxicologists*. London: Taylor & Francis, 2002.

- Grosz, Elizabeth. *Chaos, Territory, Earth: Deleuze and the Framing of the Earth*. New York: Columbia University Press, 2008.
- Guins, Raiford. *Edited Clean Version: Technology and the Culture of Control*. Minneapolis: University of Minnesota Press, 2009.
- Hacking, Ian. *Representing and Intervening: Introductory Topics in the Philosophy of Natural Science*. Cambridge, UK: Cambridge University Press, 1983.
- Hallward, Peter. *Out of this World: Deleuze and the Philosophy of Creation*. London and New York: Verso, 2006.
- Han, Beatrice. *Foucault's Critical Project: Between the Transcendental and the Historical*. (Edward Pile, Trans.). Stanford: Stanford University Press, 2002.
- Hansen, Mark B. N. *New Philosophy for New Media*. Cambridge, MA: MIT Press, 2004.
- Hardt, Michael, and Antonio Negri. *Empire*. Cambridge, MA: Harvard University Press, 2000.
- Hardt, Michael, and Antonio Negri. *Multitude: War and Democracy in the Age of Empire*. New York: Penguin Group, 2004.
- Haraway, Donna. *Modest_Witness@Second_Millennium.FemaleMan_Meets_OncoMouse: Feminism and Technoscience*. New York and London: Routledge, 1997.
- Harman, Graham. *Guerilla Metaphysics: Phenomenology and the Carpentry of Things*. Peru, IL: Open Court Publishing, 2005.
- Harthorn, Barbara Herr, and John W. Mohr (eds.). *The Social Life of Nanotechnology*. New York: Routledge, 2012.
- Harvey, David. *A Brief History of Neoliberalism*. Oxford: Oxford University Press, 2007.
- Hayak, F.A. *The Road to Serfdom: Texts and Documents: The Definitive Edition*. Bruce Caldwell, ed. New York, Routledge, 2014.
- Hayles, N. Katherine. *How We Became Posthuman: Virtual Bodies in Cybernetics, Literature, and Informatics*. Chicago, IL: University of Chicago Press, 1999.
- Hayles, N. Katherine (ed.). *Nanoculture: Implications of the New Technoscience*. Portland, OR: Intellect Books, 2004.
- Hla, Saw-Wai. "STM Single Atom/Molecule Manipulation and Its Application to Nanoscience and Technology." *Journal of Vacuum Science and Technology B* 23 (2005).
- Holland, Eugene W. *Deleuze and Guattari's Anti-Oedipus: Introduction to Schizoanalysis*. London: Routledge, 1999.

- Holmes, R.L. *Living Tissues: An Introduction to Functional Histology*. Oxford: Pergamon Press Ltd., 1965.
- Horkheimer, Max. *The Critique of Instrumental Reason*. (Matthew O'Connell, Trans.). London: Verso, 2012.
- Horkheimer, Max, and Theodor W. Adorno, *Dialectic of Enlightenment: Philosophical Fragments*. (Edmond Jephcott, Trans.). Stanford, CA: Stanford University Press, 2002.
- Huhtamo Erkki, Jussi Parikka (eds.) *Media Archaeology: Approaches, Applications, and Implications*. California: University of California Press, 2011.
- Iqbal, Pareez et al. "Nanotechnology: The "Top-Down" and "Bottom-Up" Approaches." *Supramolecular Chemistry: From Molecules to Nanomaterials* 10. (2012).
- Iwasa, Janet H. "Animating the Model Figure." *Trends in Cell Biology* 20, no. 12 (2010): 699-704.
- Jameson, Fredric. *Postmodernism, Or, The Cultural Logic of Late Capitalism*. Durham: Duke University Press, 1991.
- Jasanoff, Sheila (ed.). *States of Knowledge: The Co-production of Science and Social Order*. London: Routledge, 2004.
- Johnson, Graham T. *Automated Modeling and Visualization of the Cellular Mesoscale*. 2011.
- Kafka, Franz. *The Castle*. (Mark Harman, Trans.). New York: Schocken Books, 1998.
- Kant, Immanuel. *The Critique of Judgment*. (James Creed Meredith, Trans.). Oxford: Oxford University Press, 1952.
- Kant, Immanuel. *The Critique of Judgment*. (J.H. Bernard, Trans.). New York: Dover, 2012.
- Kant, Immanuel. *The Critique of Pure Reason*. (Norman Kemp Smith, Trans.). Boston and New York: Bedford St. Martins, 1965.
- Kant, Immanuel. *The Groundwork of the Metaphysics of Morals*. (Mary Gregor, Trans.). Cambridge, UK: Cambridge University Press, 2012.
- Kaur, IP, and R. Agrawal. "Nanotechnology: a new paradigm in cosmeceuticals." *Recent Patents on Drug Delivery and Formulation* 1, no. 2. (2007).
- Kay, Lily E. *Who Wrote the Book of Life?: A History of the Genetic Code*. Stanford, CA: Stanford University Press, 2000.
- Keller, Evelyn Fox. *The Century of the Gene*. Cambridge, MA: Harvard University Press, 2002.
- Keller, Evelyn Fox. *Making Sense of Life: Explaining Biological Development with Models, Metaphors, and Machines*. Cambridge, MA: Harvard University Press, 2003.

- Keller, Evelyn Fox, Christine R. Grontkowski. "The Mind's Eye." Sandra Harding and Merrill B. Hintikka, eds., *Discovering Reality: Feminist Perspectives on Epistemology, Metaphysics, Methodology, and Philosophy of Science*. Hingham, MA: Kluwer Academic, 1983.
- Kelty, Christopher, Hannah Landecker. "A Theory of Animation: Cells, L-Systems, and Film." *Grey Room* 17 (2004).
- Keynes, John Maynard. *The General Theory of Employment, Interest, and Money*. Harcourt, Brace & World, 1964.
- Klein, Naomi. *The Shock Doctrine: The Rise of Disaster Capitalism*. New York: Picador, 2007.
- Kracauer, Siegfried. *Theory of Film: The Redemption of Physical Reality*. Princeton, NJ: Princeton University Press, 1997.
- Lamarre, Thomas. *The Anime Machine: A Media Theory of Animation*. Minneapolis: University of Minnesota Press, 2009.
- Lambert, Gregg. *In Search of a New Image of Thought: Gilles Deleuze and Philosophical Expressionism*. Minneapolis: University of Minnesota Press, 2012.
- Lambert, Gregg. *Return of the Baroque: Art, Theory and Culture in the Modern Age*. New York: Continuum, 2004.
- Lambert, Gregg. *Who's Afraid of Deleuze and Guattari?* London: Continuum, 2006.
- Landecker, Hannah. "Cellular Features: Microcinematography and Film Theory." *Critical Inquiry* 31, no. 4 (2005).
- Latour, Bruno. *We Have Never Been Modern*. (Catherine Porter, Trans.). Cambridge, MA: Harvard University Press, 1993.
- Lawder, Standish. *The Cubist Cinema*. New York: New York University Press, 1975.
- Lazzarato, Maurizio. "Immaterial Labor." In *Radical Thought in Italy: A Potential Politics*, by Paolo Virno and Michael Hardt. Minneapolis, MN: University of Minnesota Press, 1996.
- Lazzarato, Maurizio. *Signs and Machines: Capitalism and the Production of Subjectivity*. (Joshua David Jordan, Trans.). Los Angeles: Semiotext(e), 2014.
- Leger, Ferdinand. "A Critical Essay on the Plastic Quality of Abel Gance's Film *The Wheel*." *Functions of Painting*. New York: Viking Press, 1973.
- Lemke, Thomas. *Biopolitics: An Advanced Introduction*. New York: New York University Press, 2011.
- Lenoir, Timothy. "Kant, Blumenbach, and Vital Materialism in German Biology." *ISIS* 71, no. 256 (1980).

- Lewontin, Richard. *The Triple Helix: Gene, Organism, and Environment*. Cambridge, MA: Harvard University Press, 2002.
- Lucas, George R., Jr., *The Rehabilitation of Whitehead: An Analytic and Historical Assessment of Process Philosophy*. Albany: SUNY Press, 1989.
- Luke, Timothy W. *Capitalism, Democracy, and Ecology: Departing from Marx*. Champaign, IL: University of Illinois, 1999.
- Lynn, Greg. *Animate Form*. New York: Princeton Architectural Press, 1999.
- Jean-François Lyotard. *Postmodernism Explained: Correspondence, 1982-1985*. (Don Barry, Trans.). Minneapolis: University of Minnesota Press, 1993.
- Manovich, Lev. *The Language of New Media*. Cambridge, MA: The MIT Press, 2002.
- Marx, Karl, and Friedrich Engels. "The Communist Manifesto." *Karl Marx: A Reader*. John Elster (ed.). Cambridge, UK: Cambridge University Press, 1986.
- Marx, Karl. *The Grundrisse: Foundations of the Critique of Political Economy*. (Martin Nicolaus, Tans.). London: Penguin Group, 1993.
- Massumi, Brian. *Parables for the Virtual: Movement, Affect, Sensation*. Durham, NC: Duke University Press, 2002.
- McDonough, Tom. *Guy Debord and the Situationist International: Texts and Documents*. Cambridge, MA: The MIT Press, 2004.
- McDougall, Marina. "Introduction: Hybrid Roots." *Science is Fiction: The Films of Jean Painlevé*. (Jeanine Herman, Trans.). Cambridge, MA: The MIT Press.
- McGill, Gaël. "Molecular Movies... Coming to a Lecture near You." *Cell* 133, no. 7 (2008): 1127-132.
- McLaughlin, Andrew. *Regarding Nature: Industrialism and Deep Ecology*. Albany: SUNY Press, 1993.
- McLuhan, Marshall. *Understanding Media: The Extensions of Man*. Cambridge, MA: The MIT Press, 1994.
- Medawar, Peter. *Memoirs of a Thinking Radish*. Oxford: Oxford University Press, 1986.
- Mitchell, Robert. *Bioart and the Vitality of Media*. Seattle: University of Washington Press, 2010.
- Mitchell, Robert. *Experimental Life: Vitalism in Romantic Science and Literature*. Baltimore: Johns Hopkins University Press, 2013.

- Morgan, Daniel. "Rethinking Bazin: Ontology and Realist Aesthetics." *Critical Inquiry* 32 (Spring 2006).
- Munster, Anna. *Materializing New Media: Embodiment in Information Aesthetics*. Hanover, NH: Dartmouth College Press, 2006.
- Murray, Timothy. *Digital Baroque: New Media Art and Cinematic Folds*. Minneapolis, MN: University of Minnesota Press, 2008.
- Myers, Natasha. "Molecular Embodiments and the Body-work of Modeling in Protein Crystallography." *Social Studies of Science* 38, no. 2 (2008).
- Nealon, Jeffrey T. *Foucault beyond Foucault: Power and Its Intensifications since 1984*. Stanford, CA: Stanford University Press, 2008.
- Nealon, Jeffrey T. *Post-postmodernism, Or, The Cultural Logic of Just-in-time Capitalism*.
- Negri, Antonio. *Marx Beyond Marx: Lessons on the Grundrisse*. (Harry Cleaver, Trans.). Autonomedia, 1991.
- Nocek, A.J., Phillip Thurtle. "Animating Biophilosophy 7." Special issue for *Inflexions: A Journal for Research Creation*.
- Nocek, A.J. "Imaginative Chemistry: Synthetic Ecologies and the Construction of Life." In *The Lure of Whitehead*, by Nicholas Gaskill and AJ Nocek. Minneapolis, MN: Minnesota University Press, 2014.
- Nocek, A.J. "On Symbols, Propositions, and Idiocies: Toward a Slow Technoscience." *Rethinking Symbolism: Whitehead and the Problems of Thought, Language, and Culture*. Jeffrey Bell and Roland Faber (eds.). New York: Fordham University Press (forthcoming).
- Olson, Erik. "Where Cinema and Biology Meet." November 15, 2010. <http://www.nytimes.com/2010/11/16/science/16animate.html?scp=1&sq=animation%20molecular%20biology&st=cse>.
- Painlevé, Jean. "The Beauty of Documentary Film: The Biological Film." *Monde* 18 (1930).
- Painlevé, Jean. "Les Films Biologiques." *Lumiere Radio 10* (1929).
- Painlevé, Jean. "Neo-Zoological Drama." *Science is Fiction: The Films of Jean Painlevé*. (Jeanine Herman, Trans.). Cambridge, MA: The MIT Press.
- Painlevé, Jean. "Scientific Film." *Science is Fiction: The Films of Jean Painlevé*. (Jeanine Herman, Trans.). Cambridge, MA: The MIT Press.
- Painlevé, Jean. *Science is Fiction: The Films of Jean Painlevé*. (Jeanine Herman, Trans.). Cambridge, MA: The MIT Press.

- Painlevé, Jean. "The Ten Commandments." *Science is Fiction: The Films of Jean Painlevé*. (Jeanine Herman, Trans.). Cambridge, MA: The MIT Press.
- Parikka, Jussi. *What is Media Archeology?* Malden, MA: Polity, 2012.
- Parisi, Luciana, Tiziana Terranova. "Heat-Death: Emergence And Control In Genetic Engineering And Artificial Life." *C-Theory*, 2000.
- Parisi, Luciana. "Nanoarchitectures: the Arrival of Synthetic Extensions and Thoughts." *Digital Cultures and the Politics of Emotion: Feelings, Affect and Technological Change*. A. Karatzogianni et al (ed.). Basingstoke: Palgrave Macmillan, 2012.
- Patton, Paul. "Life, Legitimation and Government." In the proceedings for the *Society for the Study of Bio-political Futures*, 2013: <http://www.biopoliticalfutures.net/ssbf-events/ssbf-syracuse-2>
- Pellizoni, Luigi, and Marja Ylönen. "Hegemonic Contingencies: Neoliberalized Technoscience and Neorationality." *Neoliberalism and Technoscience: Critical Assessments*. Luigi Pellizoni and Marja Ylönen (eds.). Surrey, UK: Ashgate, 2012.
- Piketty, Thomas. *Capital in the Twenty-First Century*. (Arthur Goldhammer). Cambridge, MA: Harvard University Press, 2014.
- Pisters, Patricia. *The Neuro-image: A Deleuzian Film-philosophy of Digital Screen Culture*. Stanford, CA: Stanford University Press, 2012.
- Poster, Mark, and David Savat. *Deleuze and New Technology*. Edinburgh: Edinburgh University Press, 2009.
- Protevi, John. "Deleuze and Life." In *The Cambridge Companion to Deleuze*, edited by Dan Smith and Henry Somers-Hall. New York: Cambridge University Press, 2012.
- Rajan, Kaushik Sunder. *Biocapital: The Constitution of Postgenomic Life*. Durham: Duke University Press, 2006.
- Ramey, Joshua. *The Hermetic Deleuze: Philosophy and Spiritual Ordeal*. Durham, NC: Duke University Press, 2012.
- Ratner, Mark, and Daniel. Ratner's *Nanotechnology: A Gentle Introduction to the Next Big Idea*. New Jersey: Prentice Hall, 2002.
- Richter, Hans. *Dada Art and Anti-Art*. (David Britt, Trans.). London: Thames and Hudson, 1997.
- Ries, Julius. "Chronophotographie de la fécondation et de la segmentation." *Travaux de l'Association de l'Institut Marey 2* (1910).

- Ries, Julius. "Kinematographie der Befruchtung und Zellteilung." *Archiv für mikroskopische Anatomie und Entwicklung* 74 (1909).
- Rodowick, D.N. *The Virtual Life of Film*. Cambridge, MA: Harvard University Press, 2007.
- Rothman, Roger. *Tiny Surrealism: Salvador Dali and the Aesthetics of the Small*. Lincoln and London: University of Nebraska Press, 2012.
- Roukes, Michael L. "Forward." *Understanding Nanotechnology*. New York: Scientific American Inc., 2002.
- Rugoff, Ralph. "Fluid Mechanics." *Science is Fiction: The Films of Jean Painleve*. (Jeanine Herman, Trans.). Cambridge, MA: The MIT Press.
- Shannon, Claude, Warren Weaver. *The Mathematical Theory of Communication*. Champaign, IL: University of Illinois Press, 1963.
- Shapin, Steven, Simon Schaffer. *Leviathan and the Air-Pump: Hobbes, Boyle, and the Experimental Life*. Princeton, NJ: Princeton University Press, 2011.
- Sharpe, Jason, Charles J. Lumsden, and Nicholas Woolridge, eds. *In Silico: 3D Animation and Simulation of Cell Biology with Maya and MEL*. Amsterdam: Morgan Kaufmann/Elsevier, 2008.
- Shaviro, Steven. "The 'Bitter Necessity' of Debt: Neoliberal Finance and the Society of Control." *DEBT Conference Sponsored by the Center 21st Century Studies, University of Wisconsin-Milwaukee* 1 (2010).
- Shaviro, Steven. *Without Criteria: Kant, Deleuze, Whitehead, and Aesthetics*. Cambridge, MA: The MIT Press, 2009.
- Shaviro, Steven. "The 'Wrenching Duality' of Aesthetics: Kant, Deleuze, and the 'Theory of the Sensible.'" *Society for Phenomenological and Existential Philosophy*, Chicago, IL (2007).
- Simondon, Gilbert. *L'individu Et Sa Genèse Physico-biologique; L'individuation à La Lumière Des Notions De Forme Et D'information*. Paris: Presses Universitaires De France, 1964.
- Smith, Daniel W. "Genesis and Difference: Deleuze, Maimon, and the Post-Kantian Reading of Leibniz." *Deleuze and the Fold: A Critical Reader*. Sjoerd van Tuinen & Niamh McDonnell (eds.). London and New York: Palgrave Macmillan, 2010
- Spector, Tami I. "The Aesthetics of Molecular Forms." In *Molecular Aesthetics*, P. Weibel and L. Frank (eds.). Cambridge, MA: MIT Press, 2013.
- Steffen, W., J. Grinevald, P. Crutzen, and J. McNeill. "The Anthropocene: conceptual and historical perspectives." *Philosophical Transactions of the Royal Society A* 369 (2011).

- Steinberg, Marc. *Anime's Media Mix Franchising Toys and Characters in Japan*. Minneapolis: University of Minnesota Press, 2012.
- Stengers, Isabelle. "'Another Science Is Possible!' A Plea for Slow Science." Lecture, Inaugural Lecture, Chair Willy Calewaert, 2012.
- Stengers, Isabelle. "The Cosmopolitical Proposal." *Making Things Public: Atmospheres of Democracy*, 2005, 994-1003.
- Stengers, Isabelle. *Cosmopolitics I*. (Robert Bononno, Trans.). Minneapolis: University of Minnesota Press, 2010.
- Stengers, Isabelle. *Cosmopolitics II*. (Robert Bononno, Trans.). Minneapolis: University of Minnesota Press, 2011.
- Stengers, Isabelle. *Thinking With Whitehead: A Free and Wild Creation of Concepts*. (Michael Chase, Trans.). Cambridge, MA: Harvard University Press, 2014.
- Stiegler, Bernard. *For a New Critique of Political Economy*. Cambridge: Polity, 2010.
- Terranova, Tiziana. *Network Culture: Politics for the Information Age*. London: Pluto Press, 2004.
- Thacker, Eugene. *The Global Genome: Biotechnology, Politics, and Culture*. Cambridge, MA: The MIT Press, 2005.
- Thoburn, Nicholas. *Deleuze, Marx and Politics*. London: Routledge, 2003.
- Thurtle, Phillip. "Animation and Vitality." *Inflexions: A Journal for Research Creation* 7 (2014).
- Turkle, Sherry, and Sherry Turkle. *Simulation and Its Discontents*. Cambridge, MA: MIT Press, 2009.
- Turvey, Malcolm. *The Filming of Modern Life: European Avant-Garde Film in the 1920s*. Cambridge, MA: The MIT Press, 2011.
- van Dijk, Jose. *The Transparent Body: A Cultural Analysis of Medical Imaging*. Seattle: University of Washington Press, 2005.
- Vesalius, Andreas. *On the Fabric of the Human Body: A Translation of De Humani Corporis Fabrica*. (William Frank Richardson, Trans.). San Francisco, CA: Norman Publishing, 1998.
- Vesna, Victoria, and James Gimzewski. "The Nanomeme Syndrome: Blurring of Fact and Fiction in the Construction of a New Science." *Technoetic Arts: A Journal of Speculative Research* 1.1 (2003).

- Virno, Paolo. *A Grammar of the Multitude: For an Analysis of Contemporary Forms of Life*. (Isabella Bertolotti, James Cascaito, and Andrea Casson, Trans.). Cambridge, MA: The MIT Press, 2004.
- von Andrian, Ulrich H., Charles R. Mackay. "T-Cell Function and Migration — Two Sides of the Same Coin." In *The New England Journal of Medicine* 343 no. 14 (2000).
- Waddington, C.H. *New Patterns in Genetics and Development*. New York: Columbia University Press, 1962.
- Waldby, Cathy, and Robert Mitchell. *Tissue Economies: Blood, Organs, and Cell Lines in Late Capitalism*. Durham: Duke University Press, 2006.
- Weibel, Peter, Ljiljana Fruk (eds.), *Molecular Aesthetics*. Cambridge, MA: The MIT Press, 2013.
- White, Michael. *De Stijl and Dutch Modernism*. Manchester: Manchester University Press, 2003.
- Whitehead, Alfred North. *Modes of Thought*. New York: The Free Press, 1968.
- Whitehead, Alfred North. *Process and Reality*. New York: The Free Press, 1978.
- Whitehead, Alfred North. *Science and the Modern World*. New York: The Free Press, 1967.
- Whitehead, Alfred North. *Symbolism: Its Meaning and Effect*. New York: Fordham University Press, 1985 [1927].
- Wieczorek, Marek. "Mondrian's First Diamond Composition: Hegelian Spatial Totality in the Starry Sky." *Meanings of Abstract Art: Between Nature and Theory*, P. Crowther and I. Wünsche (eds.) New York and London: Routledge, 2012.
- Wiener, Norbert. *Cybernetics; Or, Control and Communication in the Animal and the Machine*. New York: M.I.T. Press, 1961.
- Williams, James. *Gilles Deleuze's Difference and Repetition: A Critical Introduction and Guide*. Edinburgh: University of Edinburgh Press, 2003.
- Wolfe, Cary. *Before the Law: Humans and Other Animals in a Biopolitical Frame*. Chicago: University of Chicago Press, 2012.
- Wolfram, Stephen. *A New Kind of Science*. Champaign, IL: Wolfram Media Inc., 2002.
- Zalasiewicz, Jan. et al. "The New World of the Anthropocene." *Environmental Science and Technology* 44, no. 7 (2010).
- Zepke, Stephen. *Art as Abstract Machine: Ontology and Aesthetics in Deleuze and Guattari*. New York and London: Routledge, 2005.
- Zizek, Slavoj. *Organs Without Bodies: On Deleuze and Consequences*. New York and London: Routledge, 2004.

Filmography

Acera ou Le bal des sorcières/Acera or The Witches' Dance. Directed by Jean Painlevé, 1972. Film.

Ballet mécanique. Directed by Fernand Léger and Dudley Murphy, 1924. Film.

Le Bernard l'ermite/The Hermit Crap. Directed by Jean Painlevé, 1929. Film.

Caprelles et Pantopodes/ Caprella and Pantopoda. Jean Painlevé, 1930. Film

Crabes/Crabs. Directed by Jean Painlevé, 1930. Film.

Crevettes/Shrimp. Directed by Jean Painlevé, 1930. Film.

La Daphnie/The Daphnia. Directed by Jean Painlevé, 1929. Film.

Entr'acte. Directed by René Clair, 1924. Film

L'Etoile de mer. Directed by Man Ray, 1928. Film.

Finding Nemo. Directed by Lee Unkrich and Andrew Stanton, 2003. Animation.

L'Hippocampe/The seahorse. Directed by Jean Painlevé, 1934. Film.

Hyas et Stenorinques, crustaces marins/Haya and Stenorhynchus, Marine Crustaceans.
Directed by Jean Painlevé, 1929. Film.

The Inner Life of the Cell. Directed by John Liebler. XVIVO, 2006. Animation.

Metropolis. Directed by Fritz Lang, 1927. Film.

mours de la pieuvre/Love Life of the Octopus. Directed by Jean Painlevé, 1965. Film.

Nosferatu. Directed by F. W. Murnau, 1922. Film.

L'œuf d'épinoche : de la fécondation à l'éclosion/Stickleback's Egg: From Fertilization to Hatching. Directed by Jean Painlevé, 1927. Film.

Les Oursins/Sea Urchins. Directed by Jean Painlevé, 1929. Film.

La Pieuvre/The Octopus. Directed by Jean Painlevé, 1928. Film

Les pigeons du square/Pigeons of the Square. Directed by Jean Painlevé, 1982. Film.

Powering the Cell: Mitochondria. Directed by John Liebler. XVIVO, 2010. Animation.

La roue. Directed by Abel Gance, 1922. Film

Rhythmus 21/Rhythm 21. Directed by Hans Richter, 1921. Animation.

Shrek. Directed by Vicky Jenson and Andrew Adamson, 2001. Animation.

Un Chien andalou. Directed by Luis Buñuel and Salvador Dalí, 1929. Film.

Le Vampire/The Vampire. Directed by Jean Painlevé, 1945. Film.