

MEMES + GENES

Pursuing Innovation in Education & Design Through Our Natural Learning Processes

Bryan Washko

A Thesis Submitted in Partial Fulfillment of the Requirements for the Degree of  
Master of Architecture

University of Washington

2018

Committee:  
Vikramaditya Prakash  
Kimo Griggs

Program Authorized to Offer Degree:

Architecture

© Copyright 2018

Bryan Washko

# MEMES + GENES

Pursuing Innovation in Education & Design Through Our Natural Learning Processes

Bryan Washko

University of Washington 2018

Committee:

Vikramaditya Prakash

Kimo Griggs

## ABSTRACT:

In contemporary society, we have a species-wide tendency to congregate amongst others who are like-minded. This extends beyond simple human relationships to our educational systems and careers. While not directly threatening, I question the sustainability and effectiveness of our focus on specialization to the point of self-importance. The sense of being pleased with one's level of ability within one frame of reference simply leads to an absence of conflict and the decay of thought. While surrounding oneself with those that are similar creates comfort and security, the discomfort and conflict bred by diversity is what brings forth innovation and growth. I posit that, much like how all of nature benefits from a diverse genetic pool, so too does conscious thought benefit from a diverse experience. This thesis aims to explore the application of memetic principles to an educational environment, encouraging the passive sharing of information with the aid of architecture and technology. It seeks to understand the differences and similarities between 'silos' of thought that would traditionally be taught within somewhat of a vacuum. This train of thought hopes to develop a design language that not only fosters the promise of a truly interdisciplinary education, but also elevates human thought to embrace the diversity of subjective experience and the power that such diversity brings to the concept of the societal gene pool of culture.

# MEMES + GENES

Pursuing Innovation in Education & Design Through Our Natural Learning Processes

Bryan Washko

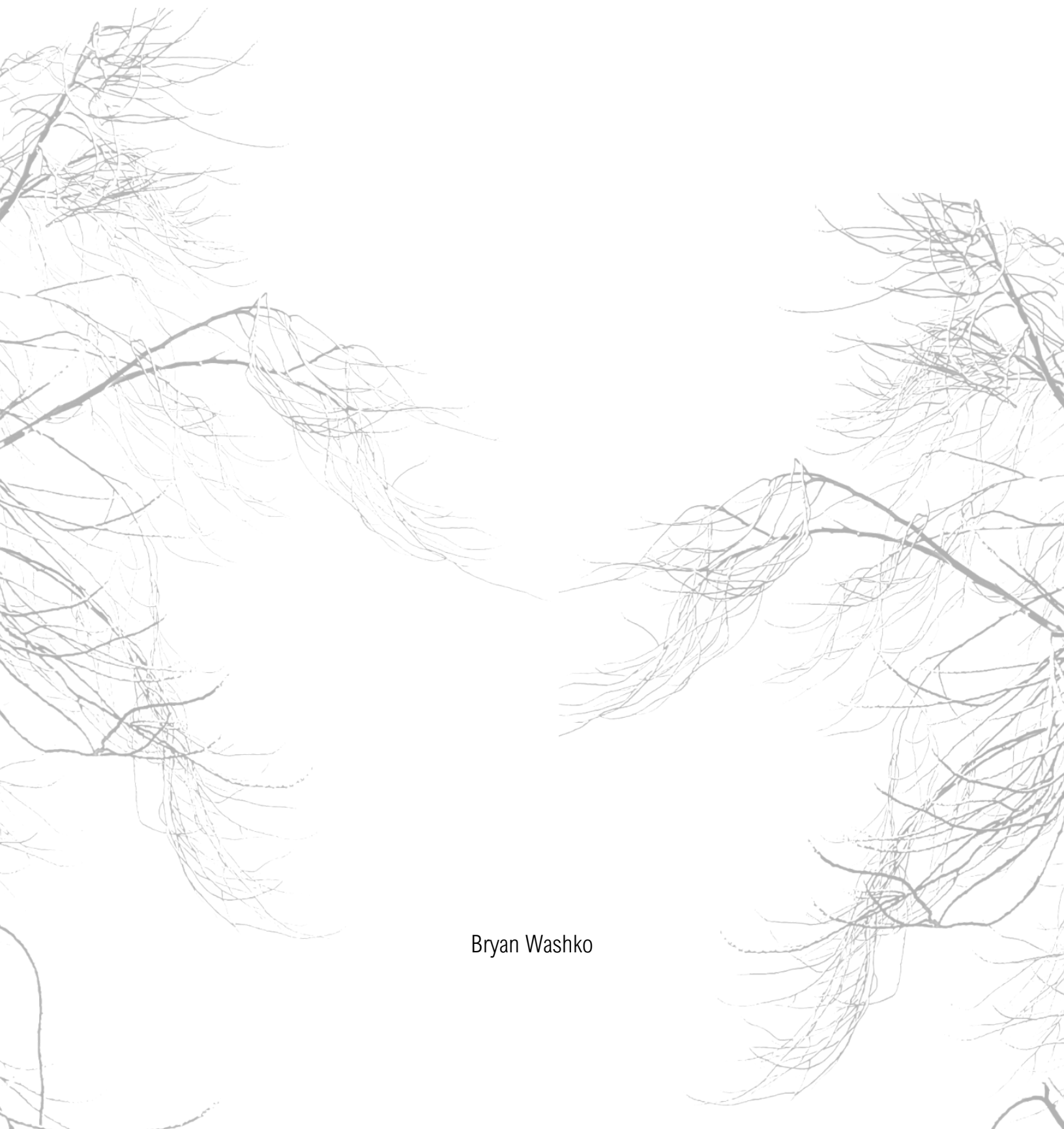

Thank You Vikram & Kimo  
For the Advice & Encouragement

To Rebecca  
You Are the Best Support  
I Could Ever Ask For



## TABLE OF CONTENTS

I.	GENETICS & MEMETICS	1
II.	MIMESIS	9
III.	ROBOT ROCK	19
IV.	SYNTHESIS	27
V.	PROCESS	33
VI.	CONCLUSIONS	54

# I. GENETICS & MEMETICS

When Darwin posited his theory of evolution to the world in 1859, it was met with controversy. The scientific community largely accepted his theory as a plausible explanation for the origination of the human species, however, the predominant Christian religious communities found it blasphemous. This man posed, in their mind, a direct act against god. His claim to have theorized the evolutionary chain of all things spat in the face of the story of creation and stole the power of genesis from god himself. Obviously, this is all rather ridiculous, but at the time (and still to this day) those who ascribed to their beliefs so adamantly simply could not see past what is held to be a plausible theory. They could not even consider the idea that there could be something larger than the simple idea that god

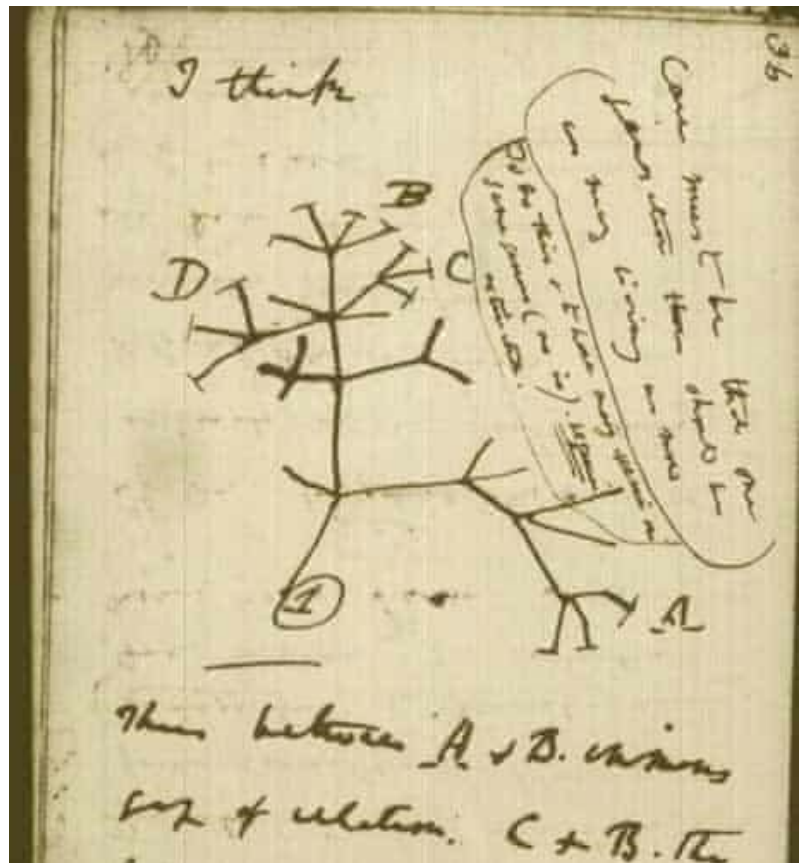

Figure 1 Darwin's Tree of Life - Source: The Guardian

spoke, and everything came into existence. Despite ages of disagreement on the matter, we still regard the Darwinism model as one of the most revolutionary theories in human history. From Darwin we began to explore even further into the realm of humanity's origin. Scientists like Dawkins brought forth ideas behind genetics, and beyond that, how genes work; how they are transferred and changed.

All living organisms have a code that dictates their physical traits. Through the work of those such as Darwin and Dawkins, we found that the backbone of evolution lies in the power of mimesis, mimicry, and subsequently evolution through adaptation; the physical response of an organism at the cellular level to change and adapt based on its environment.<sup>1</sup> The natural order of living things lies in conflict; to live is to react to oppositional stimuli. This constant chain of interaction forms the reality of the world around us. At the macroscopic level we see this in many of the cyclical systems

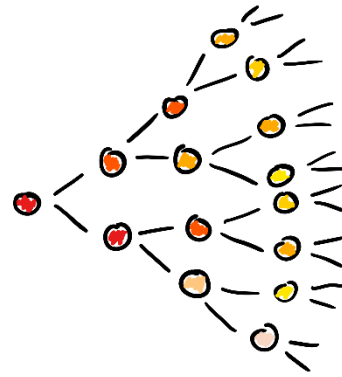

Figure 2 Chain of Conflict & Adaptation

that function as part of the natural order of the earth; the bug is eaten by the mouse which is eaten by the bird and so on.

This kind of conflict is a contest of necessity where animals struggle against one another, yet in symbiosis, to maintain their own existence. Certain traits develop in certain animals to combat being eaten such as poisonous skin or camouflage, and in response, certain predators develop the ability to see certain colors and eat indigestible foods. At a different scale, one can observe mimesis in plants. For example: An evergreen bears needles

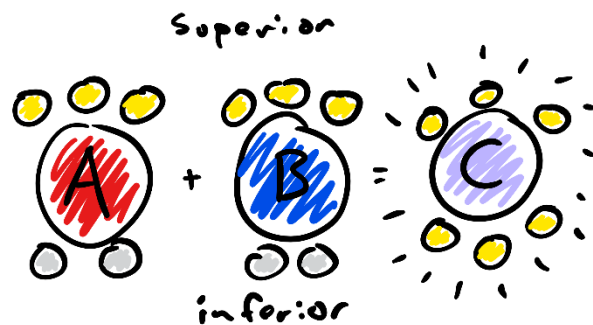

Figure 3 Diagram of Dawkins' Genetics

in place of leaves and grows in a conical form. These traits developed out of necessity in relation

<sup>1</sup> *Darwin's Theory of Evolution*, BBC; *What is Darwin's Theory of Evolution?*, LiveScience

to the environment they found themselves in. The needles of an evergreen, for example, are slender to minimize surface area and as a result prevent water loss through evaporation, yet they also grow in large quantities to provide enough general coverage so that in warmer weather, the plant can successfully photosynthesize. Compare the evergreen then, to any other tree in the natural world. The differences through adaptation, even if slight, are present and are directly relatable to the environment or climate the subject finds itself in. With an understanding of mimesis in the physiological sense, one can see the direct correlation of genetics and evolution to the sociological context. In this context, we transition to the ideas of memetics.

Memetics are functionally the genetics of thought. From birth, our experience shapes the internal gestalt of self; our sense of identity. We learn behaviorisms from our parents, who impart their own learned behavior and beliefs on us in childhood. As we mature and develop our own world-views we begin to adapt our basic behavioral framework to stimuli presented to us by the society, culture, and ideals that we surround ourselves with.<sup>2</sup>

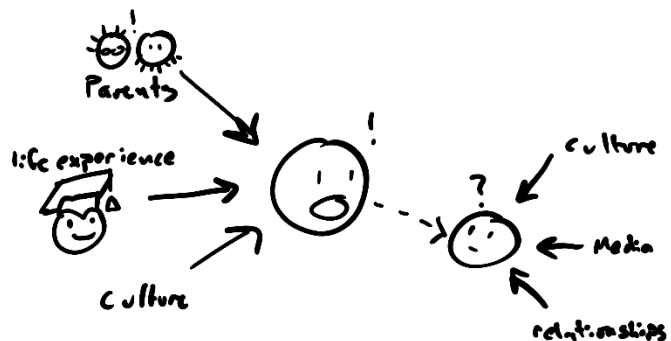

Figure 4 Propagation & Iteration of Memes

These interactions and relationships ultimately alter our initial behavioral ‘genes’ into an adapted ‘better’ form, which is of course subjective to each individual yet maintains its validity regardless. Mimesis, therefore, is effectively our way of evolving culturally, intellectually, and emotionally.

<sup>2</sup> *Memetics, Principia Cybernetica; The Selfish Gene*, Richard Dawkins

Thus far I have begun to discuss some ideas of genetics and memetics, conflict and evolution. However, for this argument I feel the need to specify the definitions of the following terms: *conflict*, *memes*, and *mimesis*. For my purposes, I am referring first, to conflict, as not just a standard example of forces in violent opposition. A conflict does not, under these circumstances, require antagonistic action. In dealing with memetics, the subjectivity of all experience is, in and of itself, conflicting with each differentiated subjective experience. Conflict, in this argument, can mean war and peace, but could also be a simple matter of human convenience such as the invention of the table in reaction to our perceived need to elevate work and eating surfaces from the ground. Memes and mimesis follow their scientific theories respectively. However, in this argument, I am posing that mimesis is not only a simple act of mimicry that is observable in almost all organics. In relation to humans it is so much more, it is the subtle ebb and flow of societal norms and ideals, and the resulting subjective experiences that are composed of the sheer volume of environmental stimulants that form our everyday existence. It is the act of adopting or oppressing ideals on our physical reality based on what is subjectively ‘correct’ to each of us. This specific topic I will address later. Memes are not only our behavioral genetics or learned values, but in addition, they are the semiotics of our existence. They are the sign and the signified, the language used to describe and communicate things and ideas and concepts, and the underlying agreements on meanings and definitions.

I believe, at the core of this argument, that the theories of genetics and memetics coincide on a level where we can understand better what it means to be human, to grow and be the best we can be. Through this understanding of how behavior, culture, ideas, and innovation cultivate and grow, we can in turn adapt and react to this information as a method of furthering education. I believe that these ideas could subsequently inform built space, so that our designs as architects can reflect

humanity's inherent ability and need to react to our environment. By designing space around subjective experience and how that experience effects a person at both the mental and physiological level, we can develop a language where space (in this case, of the educational typology) helps to cultivate an environment that supports passive information sharing, paving the way for mimesis to take place through simple indirect relationships.

## INADEQUATE

Jacques Lacan, in his writing *The Mirror Stage as Formative of the Function of the I as Revealed in Psychoanalytic Experience*, describes the psychological phenomenon of the infant 'Mirror Stage.' He observes that this phenomenon occurs roughly between the ages of six months to eighteen months. During the mirror stage period, the infant can recognize its reflection in a mirror. This behavior is notable in many other animals, but most closely is resembled in the behavior of Chimpanzees.<sup>3</sup> What differentiates the human mirror stage is the infant's own fascination with its reflection. While most other creatures lose interest after a short period, human infants find delight in the recognition of its own physical form and exhibit various levels of 'play' or interaction with the reflection. Lacan goes on to describe the psychological phenomenon at work during this stage of play and interaction as the infant developing a gestalt sense of self, or internal 'I.' This self is a formation of the infants perceptions of their physical form, where the physical incapability of their undeveloped body provides a source of conflict internally between their self and the physical circumstances of their existence. Lacan points out that this discrepancy sets the stage for

---

<sup>3</sup> Lacan, *The mirror Stage* pgs. 502, 503

humanity's lifelong internal struggle to achieve what is perceived as this perfected 'self.'<sup>4</sup> From the mirror stage onward throughout life, we exist as an introspective species that is in a constant struggle of reconciling our physical reality with the internal ideal conception of what we 'should' be or 'could' be. These internal ideals are altered and expanded based on our growth within a society and culture. What is perceived as normal, or correct, is assimilated into our fragmented, gestalt sense of self and we struggle onward to develop means to reconcile this discrepancy, or organic inadequacy as Lacan describes it, in reference to the child recognizing its own inability to take care of itself in contrast to its conception of what they perceive a human being should be.

Lacan made these observations and presented them in the year 1936, eighty-two years ago. He further developed this concept to describe not only a moment in infancy where a sense of self is developed, but rather a lifelong status that builds the framework for the entire subjective experience. It is, according to Lacan, what gives us our need and ability to formulate an imaginary order of things that we perceive. The innate desire we all maintain to order and give hierarchy to our surroundings and experiences directly relates to this lifelong mirror stage; this forever introspective reflection on our perceptions of reality in comparison to the actual perceptions themselves, what appears to be fact. With this model in mind, it becomes clear how the concept of memetics takes hold in humans. As a result of the mirror stage, we are in constant conflict with our sense of self and the new stimuli that come into existence around us in real time. We develop an image of the world and the changes that occur moment to moment through comparison and assimilation. We take in new information and attempt to then reconcile it with the existing body of memory that forms our lived experience. In doing so the self is evolved and we begin the generative process of idea-making. This system becomes the foundation of how culture is formed,

---

<sup>4</sup> *The Mirror Stage*, Lacan pg. 503

adapted, and preserved over generations. At a simplistic level this behavior can be observed in the originations of human historic chronicling. From early oral to then written history the mechanism of passing history down as verbal memory relies on the memetics of subjective experience to exist. While the intent, of course, lies in a desire for some semblance of continuity and consistency, the actual enactment of oral tradition left much to be desired insofar as its position as authoritative. This problem exists almost purely because of our incapability to be objective. Our experience, our nature is inherently subjective, which in turn puts us in a position where true objectivity is entirely impossible.

Scientists, for example, strive for what they describe as objective truth, yet the definition of objectivity in their case becomes more of an applied average of observed data to develop a truth that is as objective as possible. The truth they seek cannot ever be reliably formulated because of the inherent bias, however small and squandered, that will inevitably taint the linguistics used to describe their findings as well as the infinite level of variation and diversity found in the natural world; even the largest pool of test data will have its conflicting responses.

Brian Christensen comments in his book *The Most Human Human*, that in this age, Artificial Intelligence has become almost a new gestalt where, instead of trying to find out what we are, we learn what we are not.<sup>5</sup> Machines and computers are the only things in existence that deal in true absolute logic; humanity, by nature cannot. We can strive for a semblance of this objectivity, but as Brian points out, there comes a point when one begins to then question if we are striving to be the best humans we can be, or if we are simply trying to be machines. In a way, it almost seems as though the concept of the mirror stage ultimately leads to an innate need to order and give hierarchy, not only to the world around us, but to our gestalt selves as well.

---

<sup>5</sup> *The Most Human Human*, Christiansen

Perhaps from a psychological perspective this is why we compartmentalize and cope with traumas and other difficult emotions the way that we do; it helps develop an internal hierarchy, or system, for interacting with things that are either too complex or too painful to interact with in whole. By subdividing our experiences into digestible, ordered bits, we process them in a much more understandable way. Thus, we look to our own creation the computer, which is so effective at doing exactly that, as a mechanism to aspire to. Brian writes on this topic at length, and we will discuss this later, but first, we must look to the past to better understand memetics as a mechanism of information sharing.

## II. MIMESIS

Erich Auerbach was a German philologist (the study of oral and written language in historical source) and literary scholar of the early eighteenth century. In one of his most prominent works, *Mimesis: The Representation of Reality in Western Literature*, Auerbach describes the representation of realism in Western writing, ranging from ancient times to contemporary examples of his era. This text helps elaborate the concepts I am trying to explain about the transferring of historical representation and the notion of truth in historical writing. I feel his writing is a crucial example of mimesis as a foundational aspect of human existence.<sup>6</sup>

### THE ELOHIST AND HOMER

Auerbach begins with the oldest known texts in human history, or at least the most prominent of the time; *The Bible*, and *The Iliad & The Odyssey*. In this first set of comparisons, we delve into the differences present between what is presented as Greek historicism through Homeric legend, and the creation-based chronology of the Judaic writings of the Elohist. In Homeric writing, there is a consistent sense of storytelling that is defined by a lack of self-reference or background information. Nothing in the Homeric style is inferred or implied. As events occur throughout the legend, they are presented in what Auerbach describes as a ‘wholly-illuminated’ manner. Homer presents each scenario and portion of the story as though in a framed picture plane. The story is presented in a theatrical manner where every detail and intention is espoused and explained so that

---

<sup>6</sup> *Erich Auerbach*, Encyclopedia Britannica, Par. 1

no information escapes the reader. In service to this mechanism of presentation, the chronological order of the story is constantly broken with interjections.

This is how Homer escapes the need for backstory or inference.

Take, for example, the scene in which Odysseus returns home at last and the old housekeeper Euryclea, who was his nurse since a young age, recognizes him by a scar on his thigh. Auerbach elaborates on the storyline:

“The stranger has won Penelope’s good will; at his request she tells the housekeeper to wash his feet, which, in all old stories, is the first duty of hospitality toward a tired traveler. Euryclea busies herself fetching water and mixing cold with hot, meanwhile speaking sadly of her absent master, who, is probably of the same age as the guest, and who perhaps, like the guest, is even now wandering somewhere, a stranger; and she remarks how astonishingly like him the guest looks. Meanwhile Odysseus, remembering his scar, moves back out of the light; he knows that, despite his efforts to hide his identity, Euryclea will now recognize him, but he wants at least to keep Penelope in ignorance. No sooner has the old woman touched the scar than, in her joyous surprise, she lets Odysseus’ foot drop into the basin; Odysseus restrains her with whispered threats and endearments; she recovers herself and conceals her emotion. Penelope, whose attention Athena’s foresight had diverted from the incident, has observed nothing.”<sup>7</sup>

---

<sup>7</sup> *Mimesis*, Auerbach, pg. 3

Auerbach simplifies the scene in this summary, but then goes on to point out that in Homer's writing, he spares no detail, taking time to narrate every gesture, every little dialogue and emotion and movement, even describing specifically that to quiet Euryclea at first he takes the old woman by the throat in his right hand and then draws her close with his left.

In addition to this expression of detail, Auerbach explains that among the text of the narrative, the actual scene is interrupted by more than seventy verses in which Homer diverges to explain, at the moment of Euryclea's recognition of the scar, how Odysseus received the scar in a boyhood incident while hunting boar during the time of his grandfather Autolycus. This interjection serves the purpose to "inform the reader about Autolycus, his house, the precise degree of the kinship, his character and, no less exhaustively than touchingly, his behavior after the birth of his grandson." It "follows the visit of Odysseus, now grown to be a youth; the exchange of greetings, the banquet with which he is welcomed, sleep and waking, the early start for the hunt, the tracking of the beast, the struggle, Odysseus' being wounded by the boar's tusk, his recovery, his return to Ithaca, his parents' anxious questions" and so on.<sup>8</sup> This kind of writing is what Auerbach is referring to when he describes the 'wholly illuminated' nature of Homeric writing. Homer desires to present the legend in a way that leaves nothing to the imagination. While it is accepted that the Legend is not necessarily an accepted truth or fact of exactly what happened, the intent is to narrate the legend in a manner that makes the story itself infallible. There can be no deviation of the specific legend because every detail and minutia of information is externalized and described at length for the reader to understand. Therefore, in and of itself, regardless of how people perceive the legend as dogmatic or otherwise, the legend maintains its own internal narrative as fact in its own fictional realm.

---

<sup>8</sup> *Mimesis*, Auerbach, pgs. 3,4

In stark contrast, the Elohist wrote their text not out of a desire to just present a plausible and entertaining legend, but as a moral document, a telling of the origination and history of the world infused with ethics and standards by which humans could live by. The intent of the Bible lies in the Elohist's style of writing, according to Auerbach. By writing a narrative that gives the reader just enough information for the story to maintain a level of cohesiveness without betraying itself with inaccuracies or discontinuities, the text cements itself in a position of historical authority that leaves itself open to interpretation. This capability for the work to be interpreted is the core strength of the Old Testament. Each story of the text narrates a snippet of time or major historical event, describing only the basic content of the story; the general area or setting, the amount of people (rarely actually giving names of specific individuals), and of course the presence and specific word of god as written dialogue. In fact, throughout much of the Old Testament writings, the only real moments in which information is revealed to the reader is through dialogue, infrequently between characters, and frequently between the main character of the story and god himself. This serves primarily two functions; to minimize the misinterpretation of the text through specific language used by supposedly historical figures, and to convey specifically the moral of the story; god's word to his loyal follower.<sup>9</sup>

Allowing this kind of mechanism to take precedent in the writing allowed the Elohist to produce a text that would not only provide a bottomless source of interpretive moral standards, but also a body of content that would last the ages due to its bulletproof ability to be reinterpreted and disseminated based on the specific linguistics and contextual background of any culture that chose to read and absorb the text into its belief systems.

---

<sup>9</sup> *Mimesis*, Auerbach, pg. 7

In the story of Abraham, we are told that god requests as a show of faith the life of Abraham's son, Isaac. (Genesis 22:1) "And it came to pass after these things, that God did tempt Abraham, and said to him, Abraham! And he said, Behold, here I am." Auerbach muses how jarringly different this beginning to the narrative is in comparison to the Homeric style:

"Even this opening startles us when we come to it from Homer. Where are the two speakers? We are not told. The reader, however, knows that they are not normally to be found together in one place on earth, that one of them, God, in order to speak to Abraham, must come from somewhere, must enter the earthly realm from some unknown heights or depths. Whence does he come, whence does he call to Abraham? We are not told. He does not come, like Zeus or Poseidon, from the Aethiopians, where he has been enjoying a sacrificial feast. Nor are we told anything of his reasons for tempting Abraham so terribly. He has not, like Zeus, discussed them in set speeches with other gods gathered in council; nor have the deliberations in his own heart been presented to us; unexpected and mysterious, he enters the scene from some unknown height or depth and calls: Abraham! It will at once be said that this is to be explained by the particular concept of God which the Jews held and which was wholly different from that of the Greeks."<sup>10</sup>

We see from even this small passage and Auerbach's explanation, an immediate example of the difference between Homer's stylistic narrative and the simple, yet dramatic writing of the Elohist. As pointed out, this writing is characteristic of the function of god in the Judaic (and later Christian)

---

<sup>10</sup> *Mimesis*, Auerbach, pg. 7

tradition; unlike Zeus or any of the Greek gods, the Elohist depicts god as an omnipresent force that must somehow be channeled in order to be understood. This definition of god helps to bolster the authority of the text as a moral standard where god is always an all-seeing omnipresent being capable of observing the actions of his followers. Through this mechanism, the text maintains the ability to impose a level of self-policing on its faithful which, in turn, cements the text as a source of authority in the eyes of its adherents both on behavior and self-fulfillment, as well as historical fact. Auerbach continues:

“This becomes still clearer if we now turn to the other person in the dialogue, to Abraham. Where is he? We do not know. He says, indeed: Here I am – but the Hebrew word means only something like ‘behold me,’ and in any case is not meant to indicate the actual place Abraham is, but a moral position in respect to God, who has called to him – Here I am awaiting thy command.... To realize the difference, consider Hermes’ visit to Calypso, for example, where command, journey, arrival and reception of the visitor, situation and occupation of the person visited, are set forth in many verses; and even on occasions when gods appear suddenly and briefly, whether to help one of their favorites or to deceive or destroy some mortal whom they hate, their bodily forms, and usually the manner of their coming and going, are given in detail.”<sup>11</sup>

This specificity of Homeric writing is contrasted by the displacement in which the Elohist narrates the scene between god and Abraham. Neither god nor Abraham are in a specified place, and

---

<sup>11</sup> *Mimesis*, Auerbach, pg. 8

further, god “appears without bodily form (yet he “appears”)” and only speaks a name, with no descriptive elements, simply calling out to Abraham.<sup>12</sup>

Again, in contrast to Homer’s wholly illuminated style, the speakers within the scene maintain separate levels of presence. Where in a Homeric scene, all actors may be present and voicing their thoughts actions and dialogues, Abraham is present, likely prostrate, in a non-descript location, speaking not to any person as god is not actually there. Instead Abraham is speaking to a void from which god has spoken, the imagery of the scene left in obscurity.

Following the opening interaction, the narrative begins. God has commanded that a journey take place to a relative location at a relative time. The time and specific location are not necessary, simply excess information, the reader only needs to know the basic timeframe of “early in the morning” and the general geographic location of “Jeruel in the land of Moriah.” The journey itself, Auerbach describes, takes place within a vacuum. The specific amount of time, the people met along the way, the troubles and tribulations of travelling are all discarded in favor of the simple statement that they had “went unto” the place god had told him (Abraham) to.<sup>13</sup>

The third character of the scene enters only when he has become relevant and present to the narrative. Abraham is told by god to “Take Isaac, thine only son, whom thou lovest.” There is no other description of Isaac’s character, his appearance or intelligence or desires or history, simply that Abraham loves him. By only revealing and defining Isaac’s character in this way, the reader understands the depth of god’s temptation of Abraham and that god, being all knowing and omnipresent, is very much aware of this. Auerbach comments that the intense contrast at this moment between the Elohist and Homer lies in the narratives’ embracing or refuting of suspense. Homer’s tangential offshoots and side stories and revelations serve to balance the pacing of his

---

<sup>12</sup> *Mimesis*, Auerbach, pg. 8

<sup>13</sup> *Mimesis*, pg. 9

narratives, preventing the reader from ever focusing too intently on any one conflict or plot point at any specific moment. The Elohist, in direct contrast utilizes the exact opposite to ground the reader in the emotional suspense of the story, to force the reader to become invested in the main characters' struggles.

This ultimately enforces god's goodness and power in the reader's mind when the resolution of the tale occurs. Upon reaching the summit of the mountain, god commands Abraham to bind Isaac and place him upon a sacrificial altar. In the last moment before Abraham proceeds to take Isaac's life, god sends an angel messenger to stop him and explain that Abraham has been tempted by the lord and has shown god his depth of faith.

Auerbach breaks down the cadence of an average Biblical tale by simplifying the story into a basic framework that serves the purpose of the text. The character is introduced by a simple dialogue or quick revelation of background – the immediate call and response of god to Abraham, or the simple yet effective explanation of a person's character or place in life. The subsequent conflict surrounding a person's belief in god and the situation that belief puts them in, and finally the resolution of the conflict through pure faith in god, showing the greatness of his power and love over all tribulation. It bolsters the moral value of believing in god's goodness regardless of how downtrodden and hopeless one has become.<sup>14</sup> The Old Testament, in contrast to Homer, is a dynamic telling of one interpretation of history that manages to develop an authority of its own by utilizing its own futureproofing. It maintains the values and lessons at its core while allowing the stories to be interpreted.

---

<sup>14</sup> *Mimesis*, Auerbach, pgs. 13, 14

The minimal information provided in the narrative allows the more background information that would normally damn the realism of the story, to loosely exist in a state of unimportance with the authoritarian aspects of the text existing independent of time, free of historical bias, and maintaining a semblance of immortality. Homer's epics also maintain a sort of realism and immortality, but through a mechanism that, unlike the bible, cements its authority in fiction. By being self-aware of its status as a legend, the epics can exist independent of observed historical fact. The stories are implied as having occurred but can never be proved nor disproved. Homer achieves this through his wholly-illuminated style in which every detail of every character and event and setting is explained and confirmed as canonical. By writing an air-tight narrative that is deliberately defined and explained at every step of the way, Homer created a story that becomes unquestionable and immortal. The story itself cannot be refuted nor confirmed, yet it is a legend, and as such embraces that fact, leaving the level of belief or faith to be purely at the reader's discretion, only ever presenting the story as it is.

These two separate writers in completely contrasting environments and eras, developed separate styles that managed to achieve a similar end-game (albeit different in execution). Auerbach continues his writings in *Mimesis* to do similar explanations, analyses, and comparisons throughout centuries of historical writing that are based in the same kind of realism, the same ideas of presenting supposed historical events in an attempted factual manner. He notes that the trend among all these writers lies in the underlying self-importance of the narratives they present. Each person tries to develop an increasingly objective chronicling of history. Most notable for this specific example being the writers of historical antiquity where he comments that for the first time, the trend of attempting to elevate the human perspective above that of subjectivity is actually

outwardly embraced (the goal of the writers throughout antiquity was that of objectivity, literally viewing themselves as god-like beings 'elevating themselves' above the human plane to attempt to survey all of history from a level and even perspective, completely absent of bias).<sup>15</sup>

Auerbach provides us with a perspective on human thought and memetics through writing. His analyses of historical realism throughout centuries of text help frame the reactive nature of humanity in terms of observing events, sharing that information, and eventually passing that information down through generations leading to interpretation and reinterpretation. In addition, it frames humanity's ability to carry on ideas and concepts through faith and belief, the authority of an idea or perceived truth is given to it by its own adopters. This also highlights the danger of dogmatic thought and the issue of homogeneity in the mental gene pool of humans.

---

<sup>15</sup> *Mimesis*, Auerbach, pgs. 20,37,38

### III. Robot Rock

The digital age of Artificial Intelligence began decades ago with a man named Alan Turing. His initial research and execution of his conceptual mathematics to bring into being the first ever computer is marked as one of the most pivotal and influential turning points in recent history. He observed that businesses, scientists, and many other institutions pooled together large amounts of human labor (primarily women at the time) to essentially process large amounts of mathematics for various purposes. This, coupled with other inspirations, led Turing to develop the idea that we could effectively save people time and money by replicating the “human computer” (literally meant as “one who computes numbers”) in mechanical form through a complex series of equations and mechanical systems. In this way, Turing saw a problem, and through his own experience and observations, developed an innovative solution that ended up being the gateway to some of the most advanced technological growth the human species has ever seen.<sup>16</sup>

Brian Christiansen begins his writing by highlighting the story of Turing, and then carrying this origin story into the narrative of a play by play description of his experience participating in the annual conference of Artificial Intelligence developers in which the most cutting-edge AIs are put to the famous “Turing Test.” This test, and the event built around it, is based on Alan Turing’s attempt in 1950 to answer one of the earliest questions posed by computer science: can machines think? “That is, would it ever be possible to construct a computer so sophisticated that it could actually be said to be thinking, to be intelligent, to have a mind? And if indeed there were, someday such a machine: How would we know?”<sup>17</sup>

---

<sup>16</sup> *The Most Human Human*, Brian Christiansen, pg. 10

<sup>17</sup> *The Most Human Human*, pg. 4

He goes on to describe the experiment proposed by Turing as such:

“A panel of judges poses questions by computer terminal to a pair of unseen correspondents, one a human “confederate,” the other a computer program, and attempts to discern which is which. There are no restrictions on what can be said: the dialogue can range from small talk to the facts of the world (e.g., how many legs ants have, what country Paris is in) to celebrity gossip and heavy-duty philosophy – the whole gamut of human conversation. Turing predicted that by the year 2000, computers would be able to fool 30 percent of human judges after five minutes of conversation, and that as a result ‘one will be able to speak of machines thinking without expecting to be contradicted.’”<sup>18</sup>

The Turing Test intends to act as a barometer of machine learning; a standard at which the line would be drawn once supposed self-awareness or thinking behaviors were observed. What is curious about this test, and the annual event built around it, is the implications of what the test (and hypothetical winner) stands for. The test, like so many philosophers and scientists throughout history, asks the question: “what makes a human a human?” Rather, how would we know what a human-like computer actually looks and acts like?

Christiansen quotes the Harvard psychologist Daniel Gilbert when he comments that “every psychologist must, at some point in his or her career, write a version of ‘The Sentence.’ Specifically, The Sentence reads like this: ‘The human being is the only animal that \_\_\_\_\_.’”<sup>19</sup>

---

<sup>18</sup> *The Most Human Human*, Brian Christiansen, pg. 4

<sup>19</sup> *The Most Human Human*, pg. 11

“We once thought humans were unique for having a language with syntactical rules, but this isn’t so; we once thought humans were unique for using tools. But this isn’t so; we once thought humans were unique for being able to do mathematics, and now we can barely imagine being able to do what our calculators can.”<sup>20</sup> Christiansen makes this comment as a musing on *The Sentence*, but he intends it to help frame most of his text moving forward. This next passage becomes a sort of thesis statement for the arguments and conversations discussed in the book:

“There are several components to charting the evolution of *The Sentence*. One is a historical look at how various developments – in our knowledge of the world as well as our technical capabilities – have altered its formulations over time. From there, we can look at how these different theories have shaped humankind’s sense of its own identity. For instance, are artists more valuable to us than they were before we discovered how difficult art is for computers?

‘Sometimes it seems’ says Douglas Hofstadter, ‘as though each new step towards AI, rather than producing something which everyone agrees is real intelligence, merely reveals what real intelligence is *not*.’ While at first this seems a consoling position – one that keeps our unique claim to thought intact – it does bear the uncomfortable appearance of a gradual retreat, the mental image being that of a medieval army withdrawing from the castle to the keep. But the retreat can’t continue indefinitely. Consider: if *everything* of which we regarded ‘thinking’ to be a hallmark turns out not to involve it, then... what is thinking?

---

<sup>20</sup> *The Most Human Human*, Brian Christiansen, pg. 12

It would seem to reduce to either an epiphenomenon – a kind of ‘exhaust’ thrown off by the brain – or worse, an illusion.

Where is the keep of our *selfhood*?”<sup>21</sup>

In a strangely Heideggerian way, The Sentence, and as Christiansen points out: the trend of development of Artificial Intelligence and the Turing Test, have all become not a signifier of what human’s are, but what we are not. The answer to “what makes a chair a chair” being the sum of what a chair isn’t, now has become “what makes a human a human?” with our answer seeming to be what *we* are not. From Christiansen’s perspective, we as a species teeter on this constantly changing line between animal and computer; what is the uniqueness of human thought, if any? Especially in the face of Artificial Intelligence and its growth, where do we draw the line and say that the Turing Test has been passed, or in contrast to that idea, what can we learn from the machines we build that are now telling us what we are not? In a way, Artificial Intelligence appears to be a pseudo externalization of Lacan’s Mirror Stage. Has AI become the gestalt of self that we are collectively trying to reconcile? Is an ever growing and ever-changing abstract model of what we perceive as our collective ideal being? If this is the case, then there is much to learn from the positive and negative traits of our machine counterparts. This is much of the conceptual framework behind Christiansen’s ideas moving forward.

---

<sup>21</sup> *The Most Human Human*, Brian Christiansen, pgs. 12,13

## HUMAN AFTER ALL

Lacan's proposition of the Mirror Stage helps frame a reasoning behind our lifelong gravitation, rather, need to order our environment and ourselves. We strive in every aspect of our lives to find or impose hierarchy on things and events that relate to our perceptions of existence. This mechanism contrasts with our seemingly natural aspects of physicality and emotion. We view right-brain functions like emotions as messy or random and unpredictable, whereas our left-brain functions are viewed as grounded in reason; logical, calculated decisions and observations instead of reactionary and instinctual ones. There is a similar trend in how we perceive our physical bodies, as messy and dirty and inferior. We are constantly frustrated by our limits and failings that seem to be beyond our control and governed by random natural happenstance. These physiological problems, most prominent being our mortality, terrify us at an existential level because they are things that we cannot control, that we cannot order and impose our will on. I feel that these mechanisms, while controlled by chemical systems in our brain from a physiological viewpoint, relate psychologically back to Lacan. If in infancy, as Lacan describes, we truly develop this psychological complex of the Mirror Stage where not only our sense of self is developed, but also our capacity to compare our physiological inferiorities to our abstract gestalt ideal of human form, then it is entirely plausible that his later assertions are valid where it is posited that we further develop this complex as a lifelong introspective order from which we compare and relate and parse out our perceived reality from subjective experience, and as a result, attempt to impose our will to order our reality in order to shape it to our ideal.

I believe that this psychological foundation that Lacan developed, at the very least, forms a large portion of what drives us to order and impose ourselves on our world, to develop systems and networks based on logical hierarchies and reason. It not only helps to give us a sense of control over a world that seems inherently chaotic and the inevitable unknown of mortality, but it also allows us to pursue this internal struggle of mind versus matter, reality versus our subjective experience, true existence in conflict with what we want to be. Christiansen draws similar relationships to how Artificial Intelligence has developed since Turing's founding of Computer Science.

“The story of the twenty-first century will be, in part, the story of the drawing and redrawing of these battle lines, the story of *Homo sapiens* trying to stake a claim on shifting ground, flanked on both sides by beast and machine, pinned between meat and math.

And here's a crucial, related question: Is this retreat a good thing or a bad thing? For instance, does the fact that computers are so good at mathematics in some sense *take away* an arena of human activity, or does it free us from having to do a nonhuman activity, liberating us into a more human life? The latter view would seem to be the more appealing, but it starts to seem less so if we can imagine a point in the future where the number of 'human activities' left to be 'liberated' into has grown uncomfortably small. What then?...

*Know thine enemy better than one knows thyself*, Sun Tzu tells us in *The Art of War*. In the case of the Turing test, knowing our enemy actually *becomes* a way of knowing ourselves. So we will, indeed, have a look at how some of these bots are constructed, and at some of the basic principles and most important results in theoretical computer science, but always with our eye to the human side of the equation.

In a sense, this is a book about artificial intelligence, the story of its history and of my own personal involvement, in my own small way, in that history. But at the core it's a book about living life.

We can think of computers, which take an increasingly central role in our lives, as nemeses: a force like *Terminator's* Skynet, or *The Matrix's* Matrix, bent on our destruction, just as we should be bent on theirs. But I prefer, for a number of reasons, the notion of *rivals* – who ostensibly want to win, and who know that competition's main purpose is to raise the level of the game. All rivals are symbiotes. They need each other. They make each other better. The story of progression of technology doesn't have to be a dehumanizing or dispiriting one.”<sup>22</sup>

Indeed, should we seek to embrace the conflict that technology brings with it, rather than fear or crumble under its pressure to adapt, we can learn and grow.

Artificial Intelligence, for Christiansen, poses the threat or conflict in Dawkins' memetics.

---

<sup>22</sup> *The Most Human Human*, Brian Christiansen, pgs. 14,15

We meet that conflict with diversity and we innovate. The danger comes with our unwillingness to lean into that discomfort and conflict, which psychologically, I attribute to Lacan's theories and our drive to find safety and comfort in a world ordered and crystallized by our own hand. We err on the side of stagnation if purely out of a desire to maintain a status quo that best fits our ideal of what we want our subjective reality to be. This conflicts with the natural order of the world, and ultimately leads to decay and collapse. Take, for example a self-proclaimed "master" of their trade, a specialist. They have dedicated their life to perfecting a specific aspect of their craft or a specific function to create value as an asset to the economy. While this certainly is appealing at face value, to climb the ladder and sit atop it happily; what happens when the world begins to progress and grow and change around this person who feels they have seen and done it all? Or alternatively, the person who grows restless at their self-induced pinnacle. When one crystallizes their experience to pause their reality around a comfortable ideal, they close themselves off to all of the reactive possibilities for growth and learning from peers and other fields that may have relevant content to that person's work. Innovation is eradicated in favor of consistency, of a machine-like experience of repetition. Inevitably that repetition leads to decay and collapse, or discontent and the resulting aftermath. The same kind of relationship and conclusions can be drawn in relation to non-specialized fields as well. Currently, the conversation has become a sticking point that machines and automation are going to take over non-specialized labor; that people will be left unemployed and destitute at the hands of an artificial intelligence. The future of our techno-dystopian nightmare truly looks bleak to this group of people, yet Christiansen makes an excellent point why this simply doesn't have to be the case. Should we rise to meet our rivals, we can only benefit and grow from being displaced from our comfort zone, purely as a result of evolution and innovation.<sup>23</sup>

---

<sup>23</sup> *The Most Human Human*, Brian Christiansen, pg. 15

## IV. SYNTHESIS

Darwin, Dawkins, Lacan, Auerbach, and Christiansen. Each of these scientists, philosophers, and writers develop a personal narrative grounded in human experience. Darwin frames our physiological growth, with Dawkins developing that story further and transferring it to a model that attempts to show how our minds function and how our behaviorisms and culture are passed down through a sort of pseudo-genetic transmissions. Lacan highlights a moment in childhood psychology at which he believes the infant develops some of its first semblances of the gestalt self. This milestone in consciousness then forms and frames the entire experience of perception and introspective relationships for that person throughout their entire life. Auerbach analyses and explains the nuances and purposes behind historic representations of realism in literature since ancient times. These analyses are a window into human thought, experience, and perception throughout millennia of reaction, observation, and subsequent chronicling of events and stories for a myriad of purposes and functions. Christiansen composes a narrative that not only informs the reader of the narrative of computer science since its foundation by Alan Turing, but also tries to frame an argument for the role and self-perception of humanity in an age of digitization and the evolution and growth of our newest rival, Artificial Intelligence. This argument is not one of self-deprecation and defeat, but rather of elevation, liberation, and reinvention of the human condition and spirit in the face of a seemingly daunting threat to the status quo and a stagnated way of life. Each sought to answer questions about humanity, our nature, our physical form, our psychology, and our role in an ever-changing world; what it means to be human. This thread carries through each narrative despite the differences between content, context, and generation. All of these concepts, philosophies, and scientific theories lie at the heart of what I am proposing here in this thesis.

## INTERDISCIPLINARITY

Over the past couple of decades, interdisciplinarity has crept into public discourse, and is further becoming an increasingly hot topic in academic and professional theaters today. The term itself has a variety of definitions depending on who is asked, and more importantly, what their interests or field of practice is. Merriam-Webster defines interdisciplinarity as “Involving two or more academic, scientific, or artistic disciplines,” whereas Google’s dictionary describes it as “the quality or fact of involving or drawing on two or more branches of knowledge.” While beyond these sources, there are countless other definitions: to some professionals it is simple collaboration with other colleagues from differing, but related fields; to some academics it is a combination of degree paths that relate to one another in sometimes cursory, sometimes in-depth manners; even still, to others it is a nonsense term that applies to fake trends in thought and education that are meaningless wastes of time and money. For my thesis, I feel that the Google description encapsulates a much clearer idea of what I think interdisciplinarity really means, or rather should mean in a contemporary context.

Interdisciplinarity, as a concept is a crucial aspect of humanity. I say this, through the lens of the writings and theories discussed thus far in this thesis. Both Darwin and Dawkins highlight as a primary proponent of their physiological theories that diversity within the gene pool allows for the strongest foundational evolutionary trends to emerge. With a wide range of genetic material to select from, biodiversity follows allowing for a more adaptive and reactive network of living organisms and physiological traits that are responsive to their environment. Organisms literally learn from one another through mimesis, adapt to stimuli such as environmental elements and

predatorial presences, and grow in tandem from that interaction. So, it would make sense then, to transfer these thoughts and concepts to Dawkins' memetics. If thought truly propagates and transfers in a similar way to genetics, then it would hold strong that diversity of thought and experience would lay the groundwork for a much more robust and flexible foundation for human thought as well.

We see the importance of relating thought across traditionalist boundaries between professions and interests. This is evidenced by the presence of interdisciplinary collegiate programs, corporate initiatives that push for diversity and collaboration within the workplace, and general public space trends such as co-working environments as well as traditional typologies that naturally developed a co-working type of atmosphere such as the coffee house or library. While these kinds of initializations of interdisciplinary mechanisms are a good starting point to allow true memetic systems to take hold, these trends are not nearly as effective as we like to believe they are. We think that these initiatives, spaces, and educational pathways are emulative of interdisciplinary thought and diversity, but the majority only serve as a cursory interrelating of ideas between two or more disciplines. They rely on observational similarities and basic relationships to foster a sense of interdisciplinarity, without truly embracing the concept as a foundational way of thinking. This is not necessarily a bad thing, but the lack of depth to these attempts is worrying, and the prolonged stagnation of these systems maintaining their current position is certainly neither effective nor sustainable. The silos of thought and discipline that have been built up by traditionalist educational systems are dense and difficult to break through. We have been trained to believe that if we specialize to the point of self-importance and master a trade, we will become an asset that will be productive and most importantly, lucrative. However, this mentality that is so engrained into our

society and economy, has caused these silos to grow and become more fortified, which, in turn, has only served to bolster the confidence of those in favor of these specializations. While this is not necessarily unnatural (as Lacan and other major philosophers and psychologists have described why we are so tied to structuralism and hierarchy) it is observably unsustainable and frankly, self-destructive. When one achieves ‘mastery’ of their field, one assumes they have developed their skills as far as needed and finds comfort in the affluence and stature afforded to them from their positioning as a leader or head of that field. This comfort breeds complacency, which in turn leads to stagnation and the hoarding of information. Instead of learning from and reacting to those around them of differing experiences and backgrounds, the master assumes that there are none outside of his or her field that know anything about his or her field and that they have achieved this status through their hard work and passion. This prevents learning and growth and leads to a slow decay as time moves on. Society progresses, but the master is stuck in place and becomes obsolete.

This, from my observations, is the predicament in which interdisciplinarity finds itself struggling to emerge from. While the future demands, from a Darwinian/Dawkinsian perspective, diversity of thought for progress and flexibility, we rally against the breaking down of these barriers, perhaps as an attempt to desperately cling to identity and sense of self and place. We find ourselves as a species stuck between a world of technological advancement, globalization, and hyper-traditionalism, in which we recognize the critical need to embrace globalism and evolution but cannot seem to reconcile the slow erosion and re-articulation of tradition and identity. This nationalist/isolationist/fascistic obsession with the crystallization of tradition and structuralism is largely rooted in current educational systems and their outdated hierarchical natures. As a result, the entire societal construct that emerges from education is influenced in the same way.

I come from a background not only of a student of architecture, but from that of a trained composer as well. My time thus far spent in the realm of music has split my experiential perspective, with my life and understanding of the world as an architect existing in a dramatically different thought space. The precedents learned from each of these disciplines, as well as my lived experiences as someone learning to enact and practice them, has framed my perspective as one of synesthetic interdisciplinarity. I see the world as both a composer and an architect, as one who sees musicality in form, and hears spaciality in song. It is from this perspective, and my lived experiences, that I formed these opinions and observations about interdisciplinarity within contemporary society. I do not write this document as a ham-fisted generalization about all of society refuting any semblance of interdisciplinary thought, rather I am attempting to call to attention that, despite some of our best efforts, this way of thinking is not regarded as the standard. Indeed, we do attempt to scratch the surface of interdisciplinary thought and how that effects practice and education, but we have only done just that. For the sake of our future as a species of thinkers and creators and philosophers, we must embrace the underlying memetic principles that lie within true interdisciplinarity. If we don't, I fear that the only inevitability is to stagnate as a society, and collapse under our own weight. If we fail to break down these walls, these silos that we ourselves have erected around ourselves to delineate and identify and aggrandize our own sense of self and ego, we will fail to grow and adapt as time passes us by and the world leaves humanity behind. As Christiansen notes, much like AI provides a rival for mankind to pit itself against once more; we too must overcome our rivalry amongst ourselves. This reaches beyond simple professional practices as well, this way of thinking encapsulates the borders we have erected globally, racism and identity, fascism and tradition. I hope that these ideas and concepts can help us to find the will to overcome our own biases and embrace diversity as a source of growth.

For the thesis, this train of thought becomes the framework for how architects and designers can begin to think about design from an interdisciplinary perspective that is not simply grounded in simple relations and collaborations amongst related fields. How we as problem solvers can begin to truly embrace external stimuli as inspirational and theoretical forces that can influence and improve our work for the better. In addition, this thesis also aims to help steer education as a concept towards a more diverse, memetic system. One that encourages information sharing across borders of race, gender, identity, interest, and profession. I firmly believe that if we were to develop an educational system that learns from traditional structuralist educational environments and programs but manages to refute the structuralist tradition that drives the formation of these problematic silos of thought, we can form an educational system that builds a flexible foundation for its student base. A foundation that provides, for lack of a better word, a sort of built-in wiggle room through the adaptability and reactivity of critical thought and memetic process. This flexibility would in turn allow those who learn this way of thinking the ability to move fluidly between disciplines in such a way that any and all theory, thought, ideation, and conceptualization from any discipline, could then inform, influence, and better any other disciplines. To me, this would then be the idyllic form of interdisciplinarity; embracing the fluidity of agential interactions so that the structure of thought that follows becomes less of a hierarchy, and more of a fluid, ever-growing network of adaptable information and thought.

## V. PROCESS

To interpret how memetics could be applied to design, I developed a process that could generate shape for a building design. This process would be an articulation of how memetics function in an active way, less of the passive information sharing this thesis is discussing for education, and more an actual enactment of how memetics function. Drawing on the context and precedent of my life as a musician and a student of design served as an impetus. From this precedent, the strongest way to articulate both interdisciplinarity and memetics in process, was to then interpret music as formal elements; inspired by the Chamberworks of Daniel Liebskind. To achieve this, I sat in a darkened room; alone to filter out any extraneous stimuli. I then listened to curated segments of selected works that had improvisational, interpretive, or parametric qualities in their composition.

The works in question were: Philip Glass' *Glassworks*, an exercise in interpretation, reinterpretation, and pattern alteration. This song was chosen due to its nature as an unfolding, parametric piece, but also due to Philip Glass' nature as a modernist composer. He himself describes in his autobiography, how he sees his works as cumulative reiterations and interpretations of his life work and experiences. He describes how in some songs there are moments where he can distinctly pick out his favorite classical pieces from his childhood; operas and symphonies he saw in his past and fell in love with. The second song selected, was Grateful Dead's *Dark Star*. Regarded by some as a throwaway hippie music group but regarded by tenfold more as one of the most innovative, visionary groups of mid-century music. Beyond their technological innovations, their work was a sort of fluid re-birth of jazz; improvisational licks superimposed over traditionalist standards. Melody constantly being entwined with a myriad of instrumental harmonies and interpretations. The nature of the band itself, and later the jam band

genre as a concept, was a sort of pseudo-memetic, reactive musical process that still holds sway over contemporary musical audiences decades later. *Dark Star* was chosen due to its position as one of the greatest improvisational pieces from the body of their entire career. The third, and final, song that was chosen, was Kamasi Washington's *Change of the Guard*. The importance of this piece lies at the core of its composition. Kamasi Washington is regarded as a contemporary jazz genius. He has slowly gained acclaim through his reinterpretation and resurgence of Coltrane-esque jazz infused with Gospel influence and qualities. Not only is he the composer of an improvisational style, but much like Glass, he has allowed his life experiences and environments to influence and further grow his musical stylings. This has in turn allowed his compositions to become a beautifully contemporary, yet classically traditional, body of work that calls on the greats of old, but makes room for new interpretation, iteration, and adaptation. *Change of the Guard*, specifically, was chosen in part due to my own preference, but also because of its special quality. The song paints an environmental image and narration through its composition, instrumentation, and pacing.

With the songs decided upon, I selected small, ten-second segments that summarized the totality of the songs themselves; segments of theme and variation and of eight-bar improvs. With these segments selected, the process became an exercise of listening to each segment, and to enact memetic principle, create blind drawings based on what was heard. My belief was that by articulating real-time interpretations of the song I was listening to, I could form a synesthetic connection between sound and form, a direct relation of music to shape elements for building mass. The conceptualized method for doing this developed as taking the two primary building components, plan and elevation/section, and tying certain musical qualities to the blind drawings, so that the product would be a set that could be utilized as 'plan' and 'elevation' drawings.

Rhythm has a certain temporal quality to it; it is pacing, compression and expansion over time. This quality was best suited to the 'ground' plane. The xy or plan in relation to the site. As such, the drawings then articulated by attempting to pull or emulate the rhythmic qualities of the song then became the plan elements for this process. In contrast, the more lyrical qualities of the song; pitch, melody, harmony, all have a quality of height to them. Pitch undulates to and from the ground plane, increasing and decreasing in height spacially, and as such, the drawings which tried to best encapsulate or react to these aspects of the compositions became elevations for the process. At the end of these exercises, I then selected the song (and its respective drawing set) that was best emulated in the exercise, and that also held the most promise in terms of the linework produced being usable (i.e. not overly complex while not being too underwhelming or simple). The song that was chosen in the end, was *Change of the Guard*, with its drawings being both usable, and most representative of the qualities of the piece itself. With this exercise being completed, I had generated what I am describing as the 'standard' in Jazz, the base composition, the rules or framework from which the rest of the piece can grow and articulate from. So, following this metaphor, the next step was to improvise, to iterate and combine these sketches as massing.

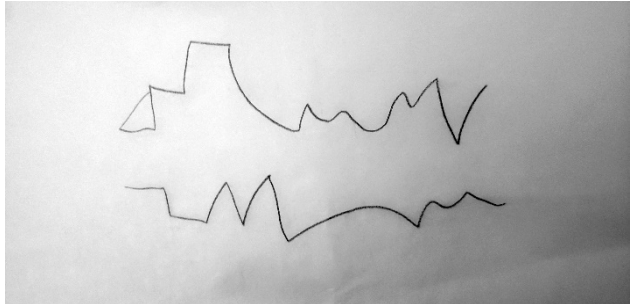
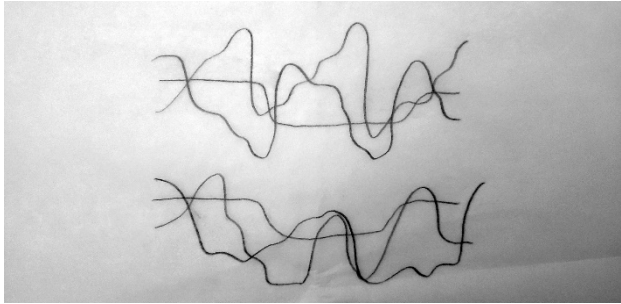
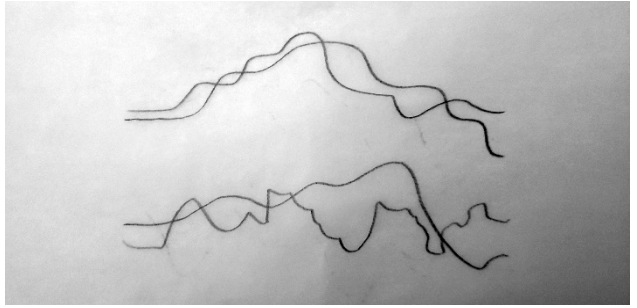
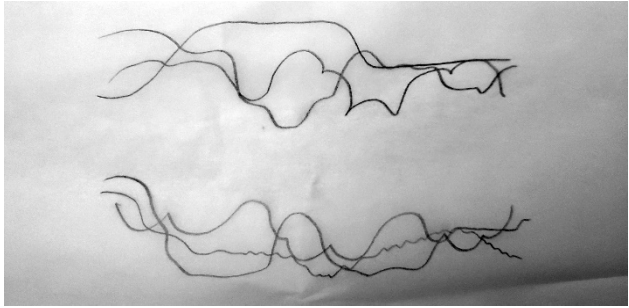

Figure 5 Blind Drawings In Plan A,B,C,D

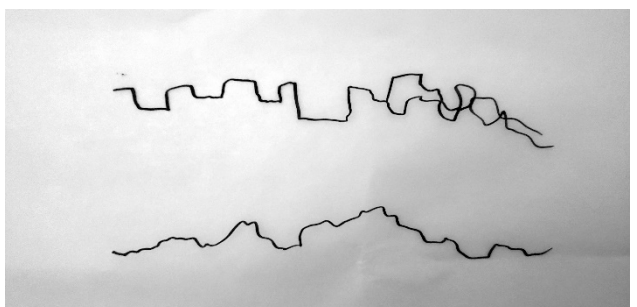
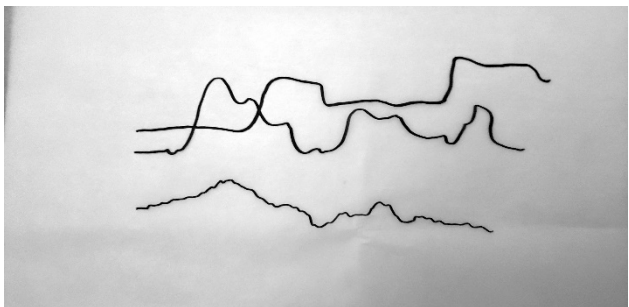
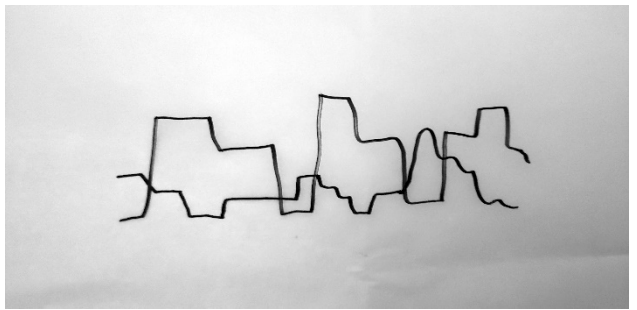
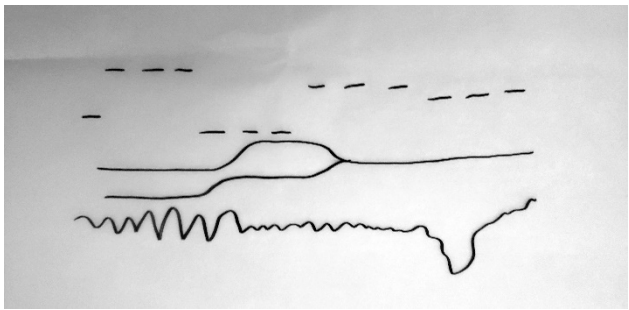
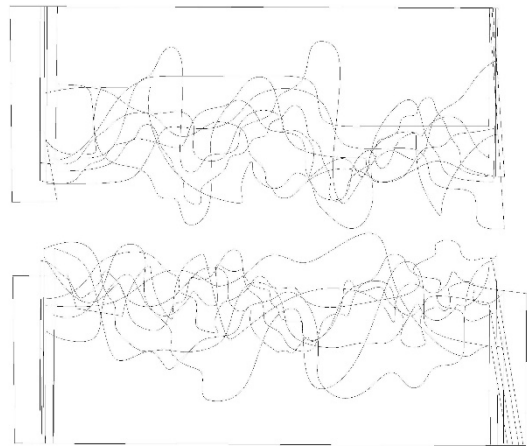

Figure 6 Blind Drawings in Elevation A,B,C,D

## IMPROVISATION

For this process, a matrix emerged as the best method for maximizing iterations as improvisation; a combination of every single elevation sketch with every single plan to achieve the maximum possible iterations of masses from this methodology. To aid in this process, I set out to compose my own piece, a programming script in the tool Grasshopper for Rhinoceros. Scripting, in a way, is also like composition. One must operate within the rules and boundaries of a set language to achieve a goal or solve a problem, and as a result I felt this tool would be the ideal way to aid my process.



*Figure 7 Plan Sketches Digitized*

After digitizing the sketches into the Rhinoceros three-dimensional environment, I began to compose a script, that allowed me to sample each sketch as an item to be categorized within a list. The structure for this data tree followed the structure needed to form

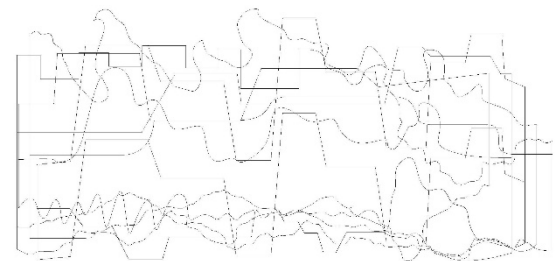

the desired combination matrix. One list of samples was the four elevation sketches from the exercise. The plans, however, were a little more difficult to sample in order to achieve the maximum possible combinations. The plan drawings were split into halves, representative of the north and south sides of the site itself.

This expanded the initial four plan drawings into 8 samples total; four under north, and four under south. Next, was to split the doubled linework present in each sketch from the north and south halves of the sketches. Each plan sketch featured four contours, representative of different rhythmic aspects of the piece, and so after separating these contours as their own profiles, the eight sketch components doubled again to sixteen, eight per list. In total, this culminated in three lists that needed to be matched in order to form the desired matrix, four elevation samples, eight north plan samples, and eight south plan samples.

To build this matrix, I had to first combine the plans as the maximum possible combinations of those two initial lists. By cross-referencing the plan lists together the script was able to list-match each item from the north group with the south group, producing sixty-four possible plan iterations of paired north and south components. The next step was to then generate enough copies of the four elevations so that each elevation component could then be paired with the sixty-four plan iterations. The dataset was duplicated

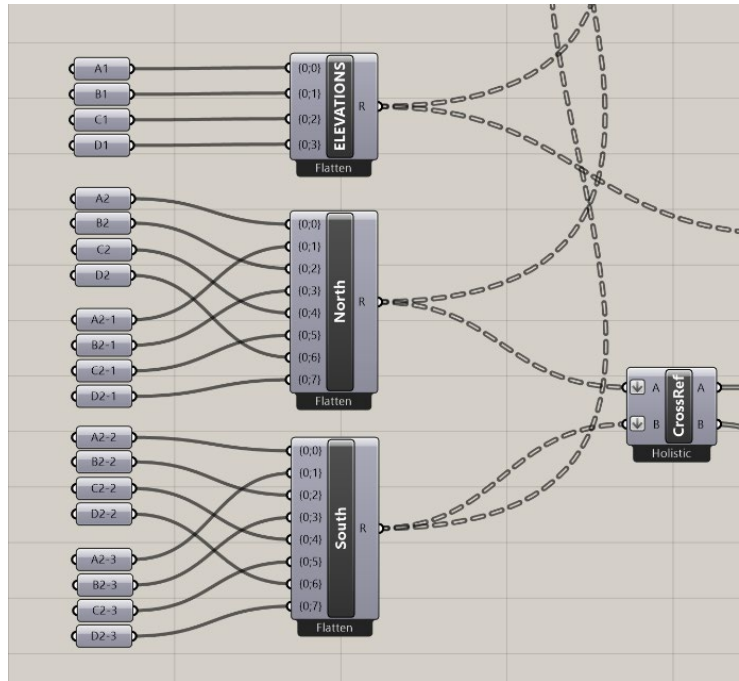

Figure 10 Grasshopper Sampling

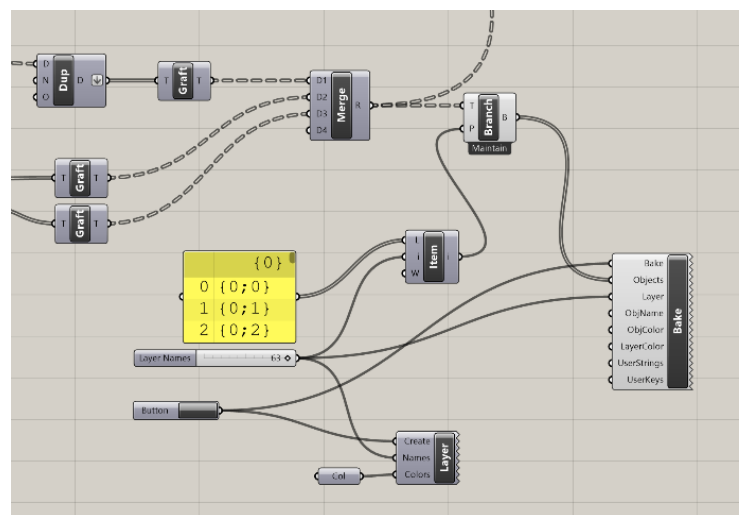

Figure 9 Grasshopper List Matching & Production

so that the list would repeat itself enough times to fill out the matrix, and then merged that branch with the list of plan iterations completing the data tree. The final output was a list of sixty-four tree branches that each had one of four elevation components, and one north and south plan component

Each of the iterations were generated as models, and then, as per my process,

underwent a simple Boolean operation to trim the extraneous material. This left a form that directly resulted from the musical exercise, a collapsing of plan and section sketches to form a sort of crystallization of the interpretation, music as shape generated through my own

memetic process. Each form was sorted under their underlying elevation sketches, named A, B, C, and D. Each list had its own set of plan iterations that allowed for a wide range of outputs to analyze. The next step was to then pare down these lists based on a criteria I developed from my experiences as a musician and a designer.

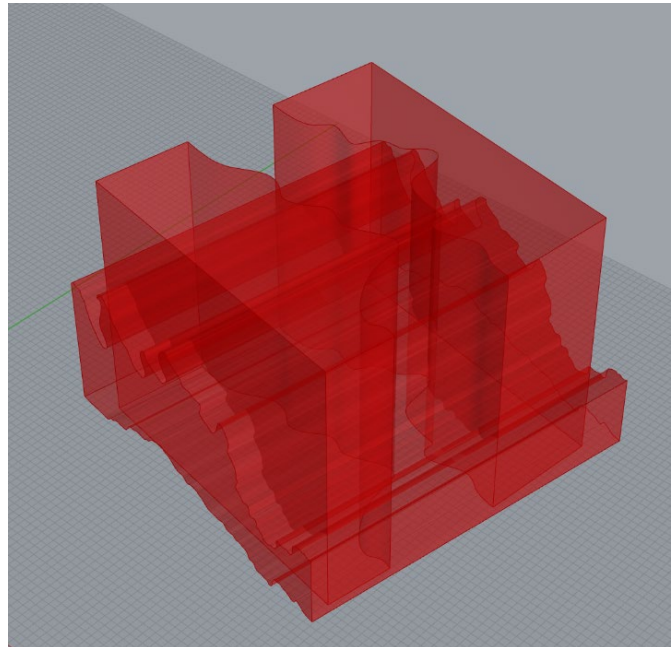

Figure 12 Boolean Product

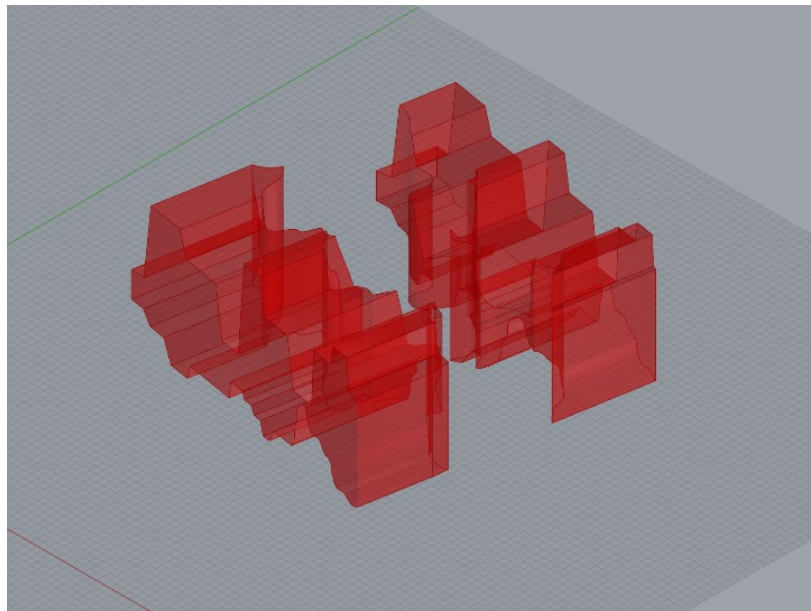

Figure 11 "Baked" Output

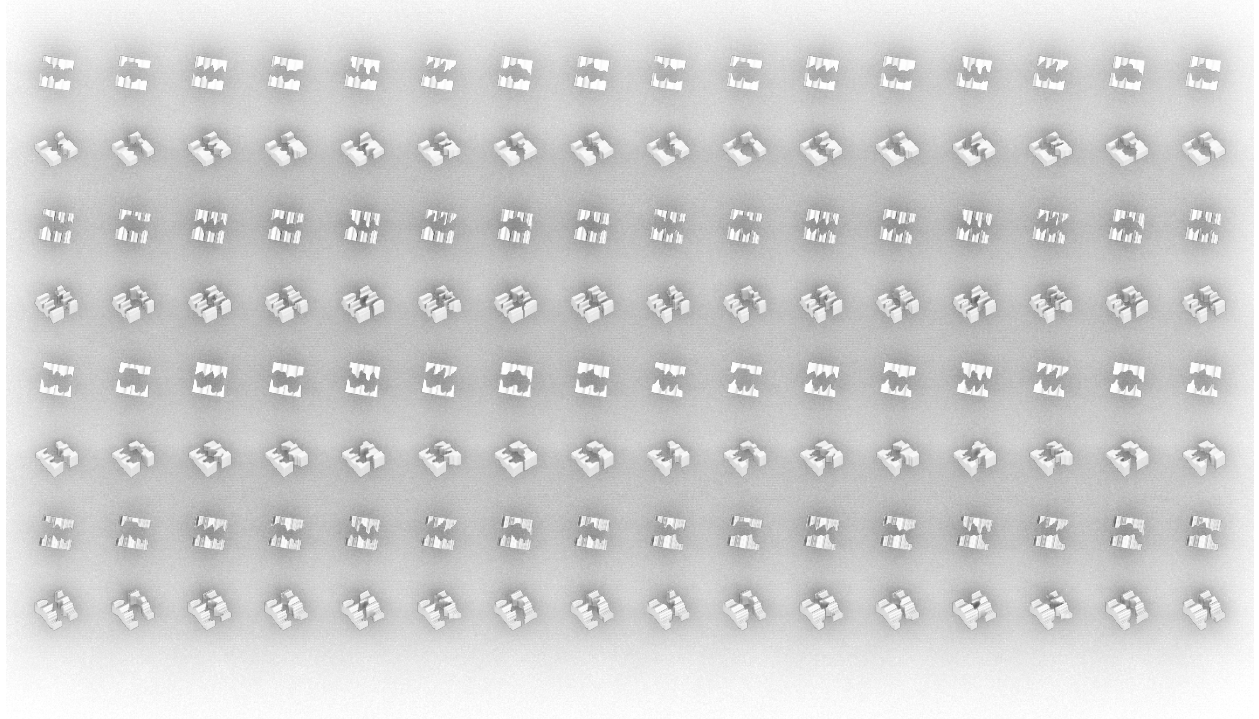

Figure 14 Sixty-Four Original Iterations

The first set of sixty-four was simplified based on the viability of the elevation profiles themselves. The criteria were based off of whether or not the shape itself was overly-complex, whether or not the mass (based on the elevation) was even programmable moving forward, how emulative of the song the actual form itself was, and in part utilized some intuition as a designer; what I felt could and couldn't actually form a building mass. Some shapes were inherently usable, whereas others simply weren't. The selection process left me with thirty-two options under lists A and C, both of which I felt, in elevation, fit the criteria. After this first round of selections, the list needed to be further sifted and trimmed. From the thirty-two masses left, I then ran another grasshopper definition that sampled the north and south halves of

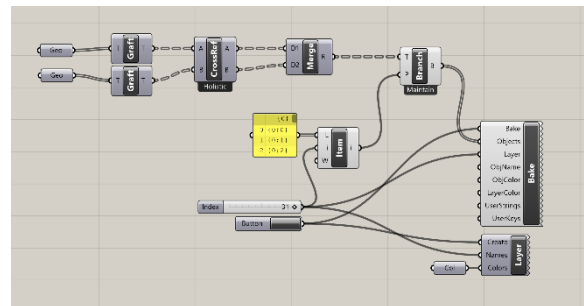

Figure 13 Second Definition For Consolidation

the masses, cross-referenced the options, removed redundancies, and produced a final list that left me with sixteen iterations. These sixteen were again grouped into foursomes that were labeled

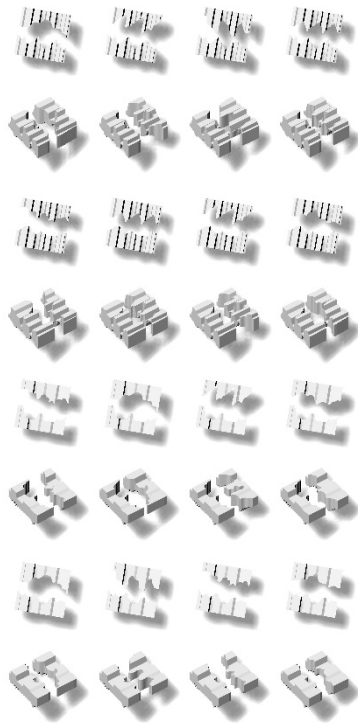

Figure 15 Sixteen from Thirty-Two

under A, B, C, and D. Following the methodology for simplifying the original sixty-four iterations; I utilized the same criteria once more to filter the list further. Unlike the original round of selection however, I no longer focused on the elevation profile, but rather

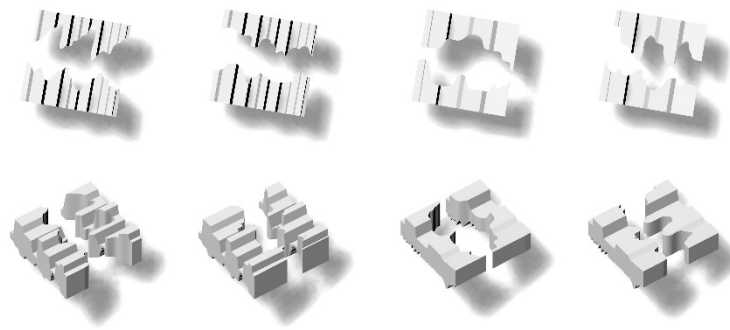

Figure 16 Final Four After Selection

applied the criteria to the masses as entire forms. From this set of sixteen, a single option from each of the four groups was selected. These selections were most exemplary of the traits that were desirable. This final four then underwent a more in-depth selection process.

In order to get a clearer idea of how each of these four masses felt experientially, I developed simple, clay renders in perspective looking toward the interior corridor between the masses. These renders showed the spacial qualities of the masses; the scale, the rhythm and



Figure 17 Mass A

fluidity, and the way that lighting interacted with and within the shapes. Through these renderings I was able to form opinions and decisions on what would ultimately make the best choice for this

building mass. The final selection, mass A, encapsulated the criteria. It was programmable, it had features that could translate into what was feasibly a building, and above all, it most exemplified the song that generated its shape; the elevation changes emulating the pitch and harmonies of the piece, and the compression and expansion of the internal void captured the feel and sensation of the song's rhythm.



Figure 18 Mass B

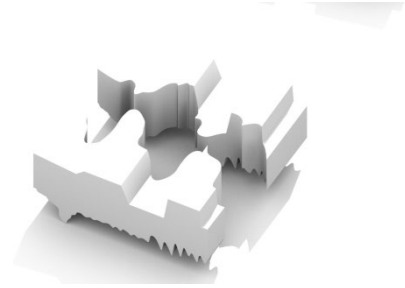

Figure 19 Mass C



Figure 20 Mass D

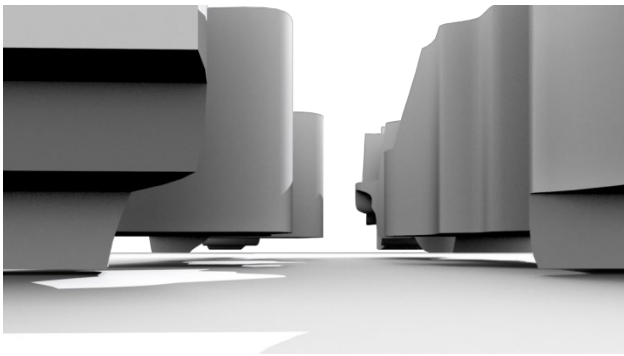

Figure 21 Mass A Renderings

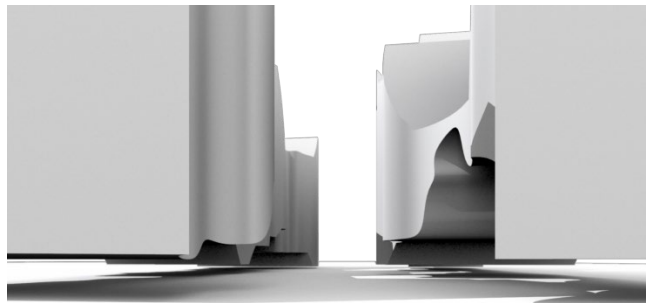

Figure 22 Mass B Renderings

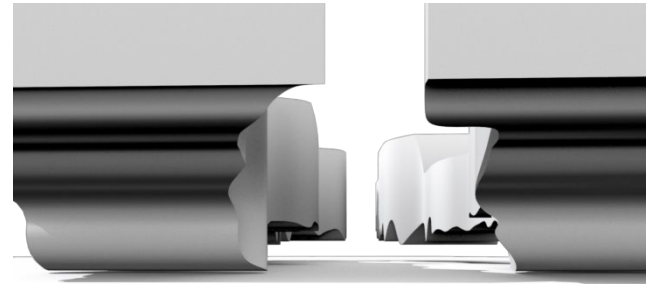

Figure 23 Mass C Renderings

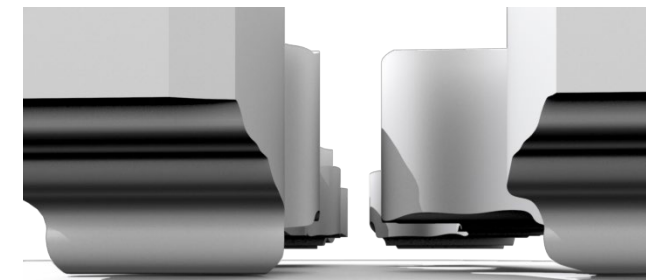
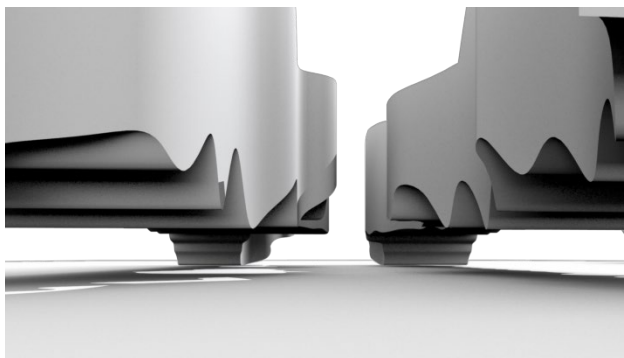

Figure 24 Mass D Renderings

## DEVELOPMENT

Left with a mass from this musical process, the project started shifting into the realm of the architectural. This started with a series of sketches where I began to break the mass down into parts that fit the original concept of the project. At the start of this process, the conception was to develop a school building, a space that intended to cultivate memetics as foundation for academia.

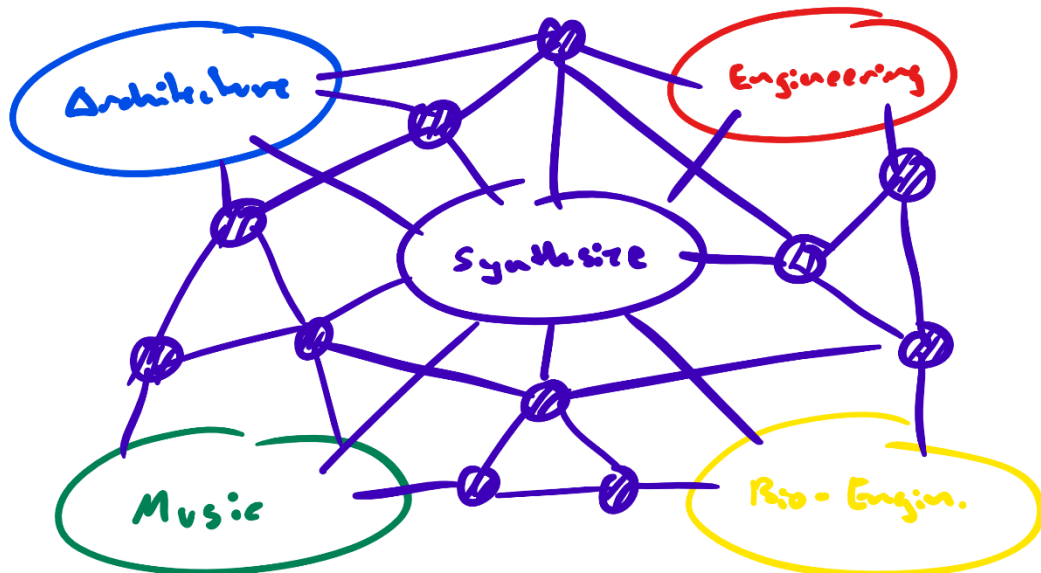

Figure 25 Concept Diagram

The initial program took the form of four silos of thought, pushed to the corners of a shape, and then knit together with a web of sinuous connective tissues that allowed the silos to begin breaking down and interact. The thought behind this being that if one were to allow the silos to start as they exist now but provide the framework for more reactive interactions to begin developing through its own volition, then the space itself would both become an adaptive, memetic space, while

providing a scaffold for this way of thinking and these information sharing interactions to grow from. In addition, following the ideals of diversity of thought, the selected disciplines for the initial silos stemmed from both right and left-brain oriented ways of thinking, with the right-brain disciplines being music and architecture, and the left-brain selections being engineering and bio-engineering. The purpose for this choice was that the differences between left and right brain processes, and the subsequent interaction of those two hemispheres, would allow a broader and more diverse interaction between these disciplines as well as holistically utilize the brains processes in a more effective and diverse manner. What developed as a pleasant coincidence was the actual massing of the building from the nature of the site and the process that created the shape. The duality of the building form matched well with the hemispheres of the brain, and subsequently the program and concept for this school. With the left and right disciplines linking to the left and right hemispheres of the masses, the next move was to blend these ways of thinking further by rotating the programmatic silos in respect to the physical hemispheres of the building. This allows for better mixing of left and right-brain ways of thinking, and as a result, a more diverse experience. The synaptic connections between the hemispheres of the brain were then represented by my initial conceptions of how the left and right hemispheres of the building interacted and were connected.

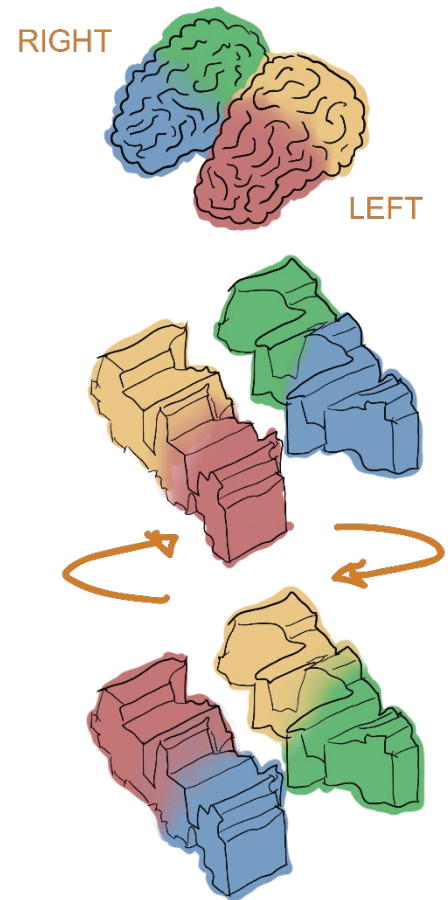

Figure 26 Hemisphere Shift

The program then, in diagram, was that of silos pushed to the corners of the masses with the shared interstitial spaces forming connective tissues within and around the void space in the center. Developing this idea further, the program benefited by being organized hierarchically along the masses themselves. The more structural, generic spaces were pushed to the far boundaries of the masses themselves, and the more fluid,

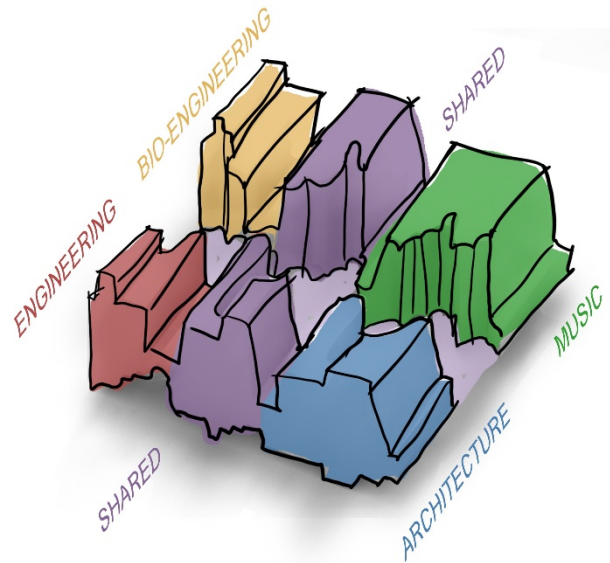

Figure 27 Massing Diagram

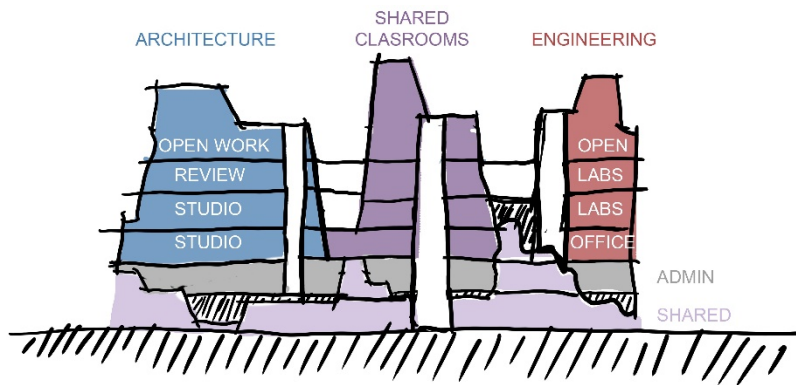
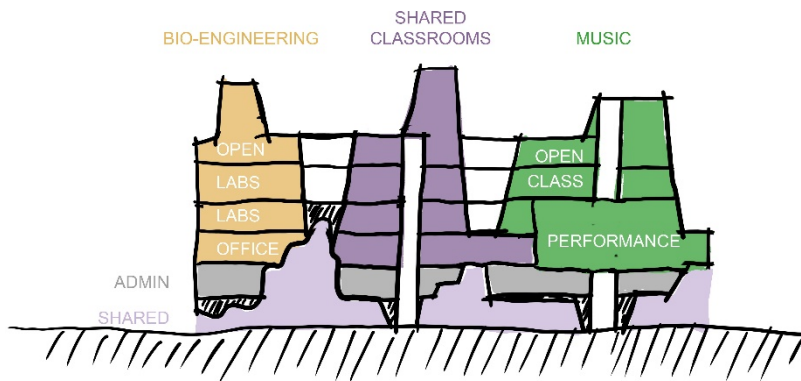
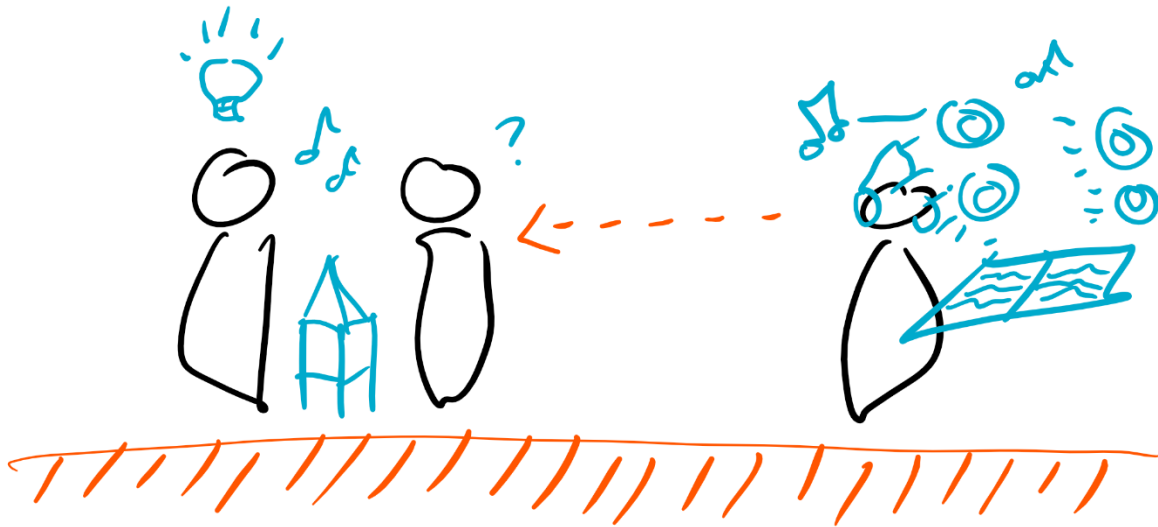

Figure 28 Northern Massing



adaptive spaces congregated around the shared central atrium. This tied to the brain analogy and allowed for the central void space to come to the forefront as the prominent design element. The resulting program was that of a solid hierarchical block, split down the middle by musical process, and filled with synaptic shared spaces where memetics and information sharing could take hold.



These shared spaces, formed by circulation and the nodes at which they connect, I envisioned as a major feature for the school. Utilizing technology as an aid. These nodes, dubbed MINDLABs, would provide a sort of digital soundstage. For example, through augmented reality systems, students, teachers, and anyone else using that technology, would be able to interact within a digital space superimposed over the workspace. Projections of the work being done in such spaces would allow for passive information sharing and influence, and collaboration to naturally occur. A student of architecture could be working on a massing model, while a bio-engineering student develops a hydroponics system, and a music student composes a new piece. Each of them, by being exposed to one another's work in this kind of projected, open environment, would in theory be influenced from one another and grow and react to the work being perceived. This enacts the principle of memetics and sets the framework for innovation and personal growth.

Further, these spaces and their connective circulation developed as emulative of the adaptability of our brain's connective tissues themselves.

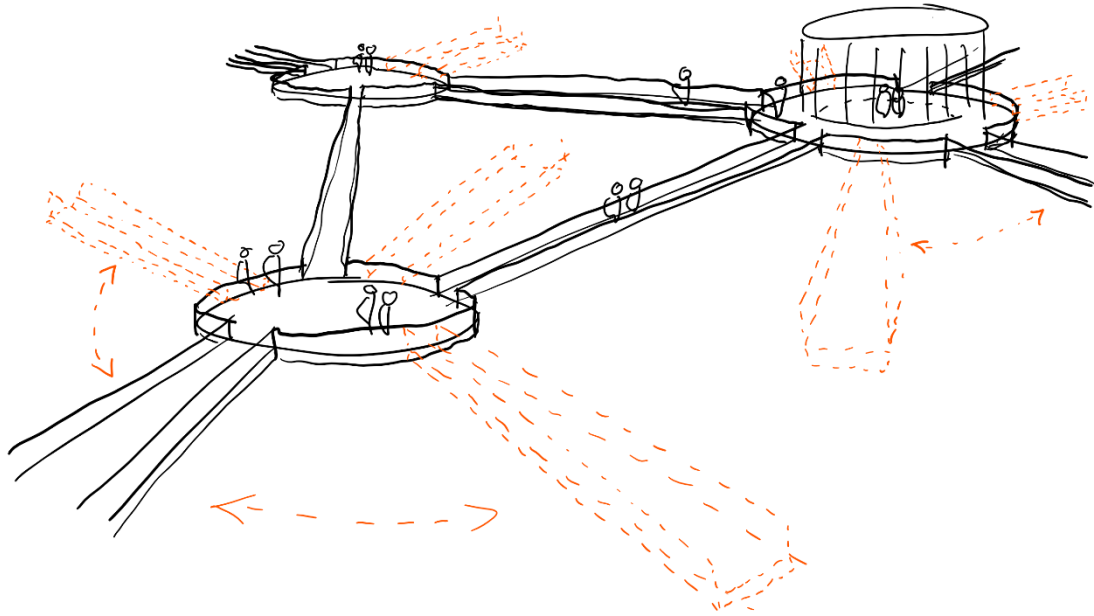

Figure 30 Bridge Functionality Diagram

Much like how our brains reformat themselves from time to time, these spaces are capable of adapting to the school itself. Class changes, guest professors, seminars; each space and its circulatory connections could be altered, moved, added to, and replaced depending on the needs of the school. To start, the design would provide a small number of these as articulated spaces intended to help set the framework for the institute to then grow from and alter according to its needs. This would of course encapsulate any future expansions to the school as well such as additional programs and disciplines. I believe that this would allow for the central space to truly become a memetic, adaptive, stage for the school to grow and eventually evolve over time.

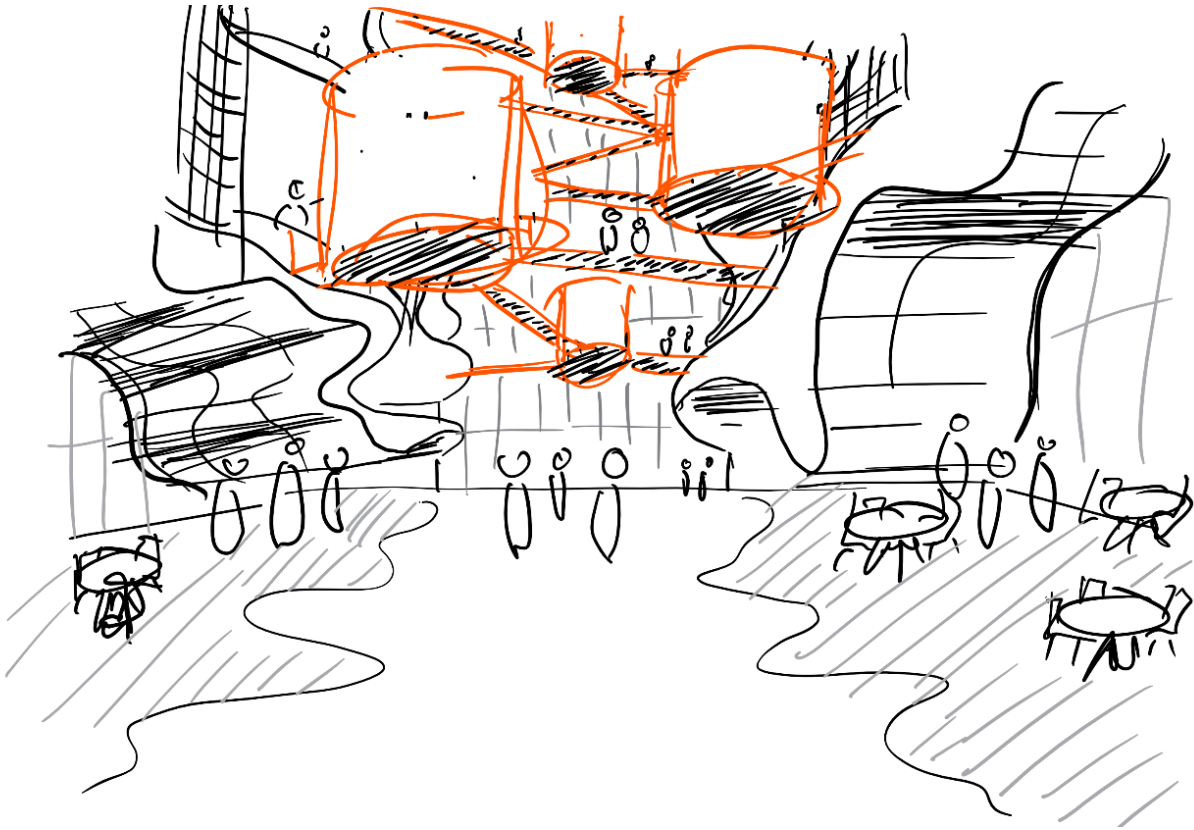

Figure 31 Sketch of Central Space

The final product was developed to the point of a simplified model that attempts to layout what this kind of school would look like. At each level, connective bridges span the void as a network of connective tissues, dotted with MINDLABs at major connection points, bordered by generic program, and encased in a box of glazing. The typology reads as a sort of warehouse building with a fractured, yet fluid, atrium; filled with an adaptive shared environment for education to expand and evolve within. The amount of connections and nodes are left at a minimal level, with the hopes that the user would immediately make the space their own. The intent is that by leaving a simple scaffold in place as a starting point, the school's users could then enact the principles of the design through adaptation and memetic process, without enforcing a crystallized form of the Architect's vision.

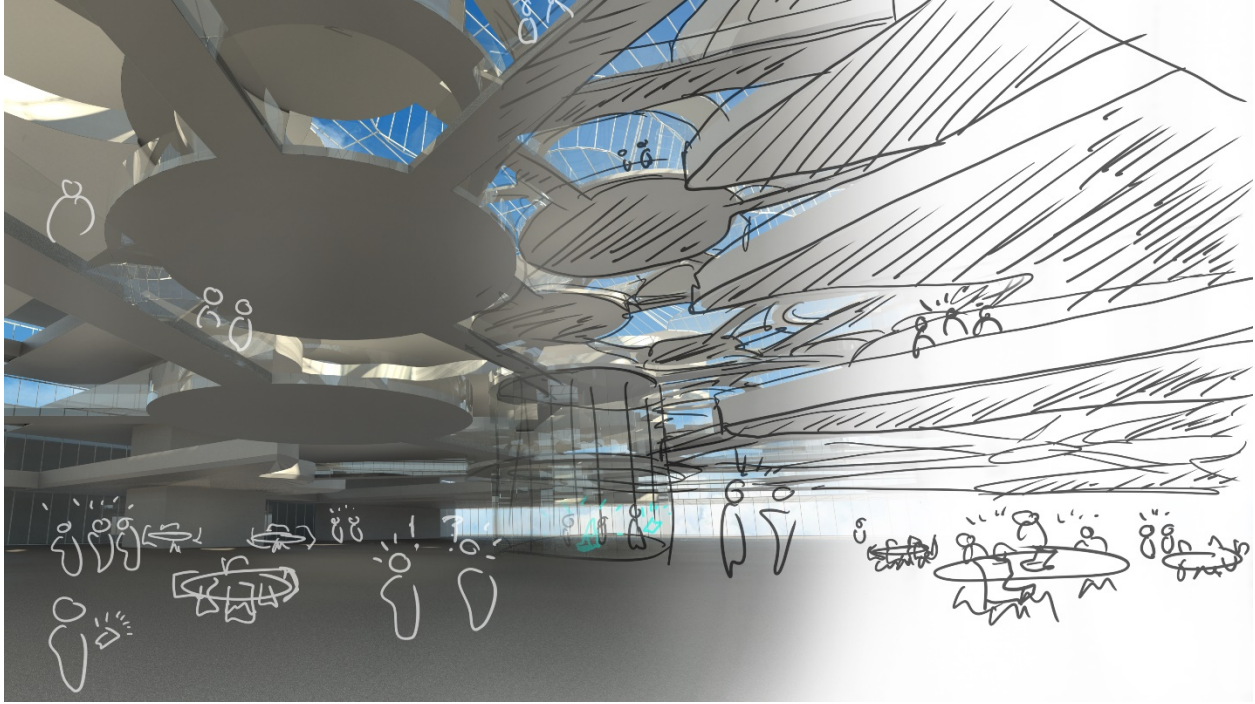

Figure 33 Interior Render A

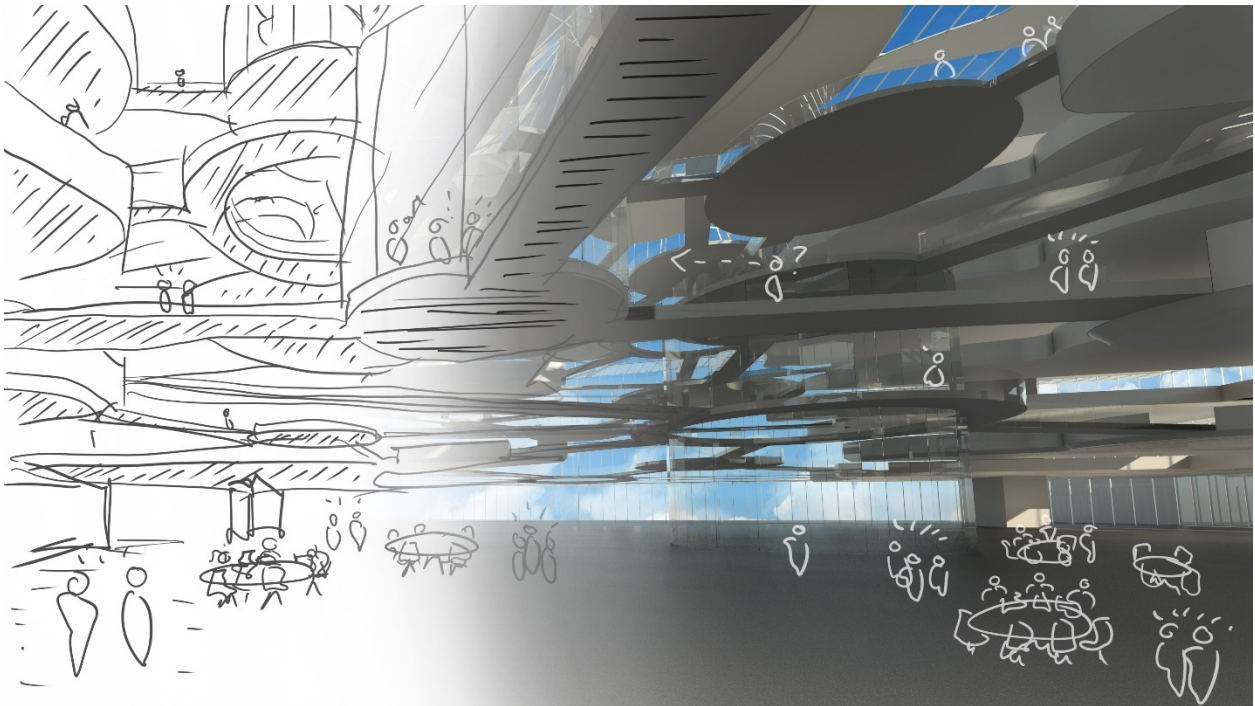

Figure 32 Interior Render B

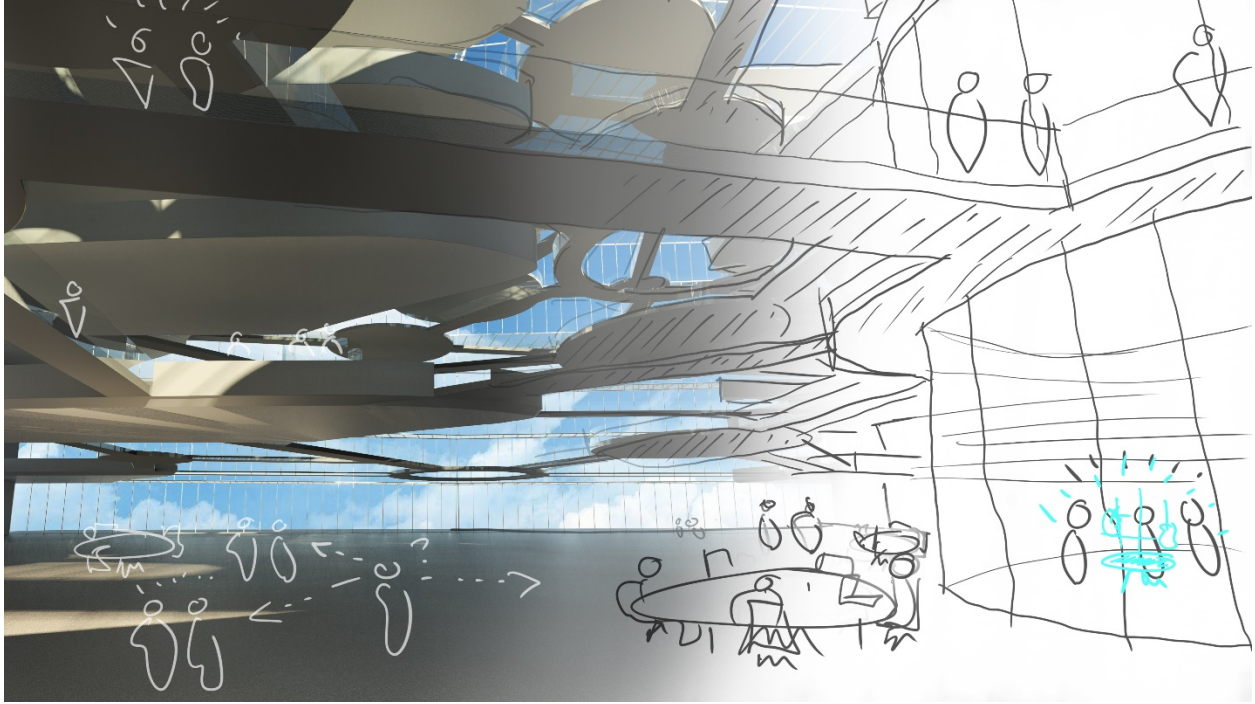

Figure 34 Interior Render C

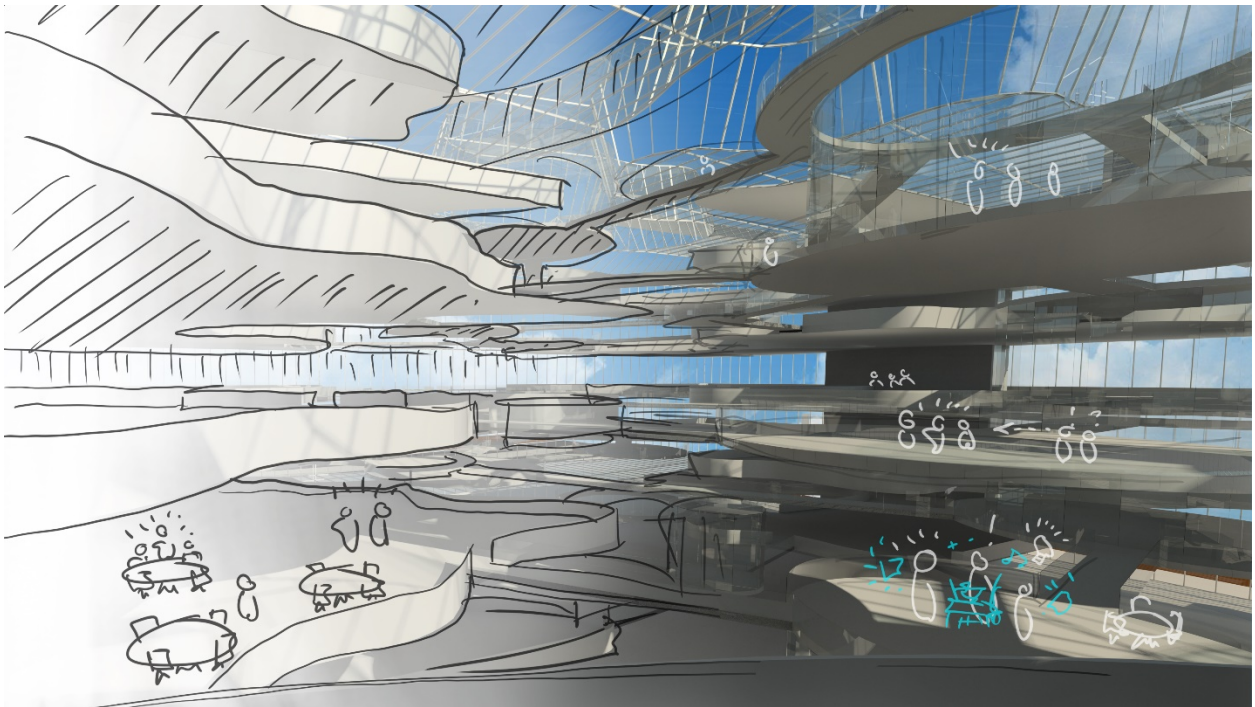

Figure 35 Interior Render D

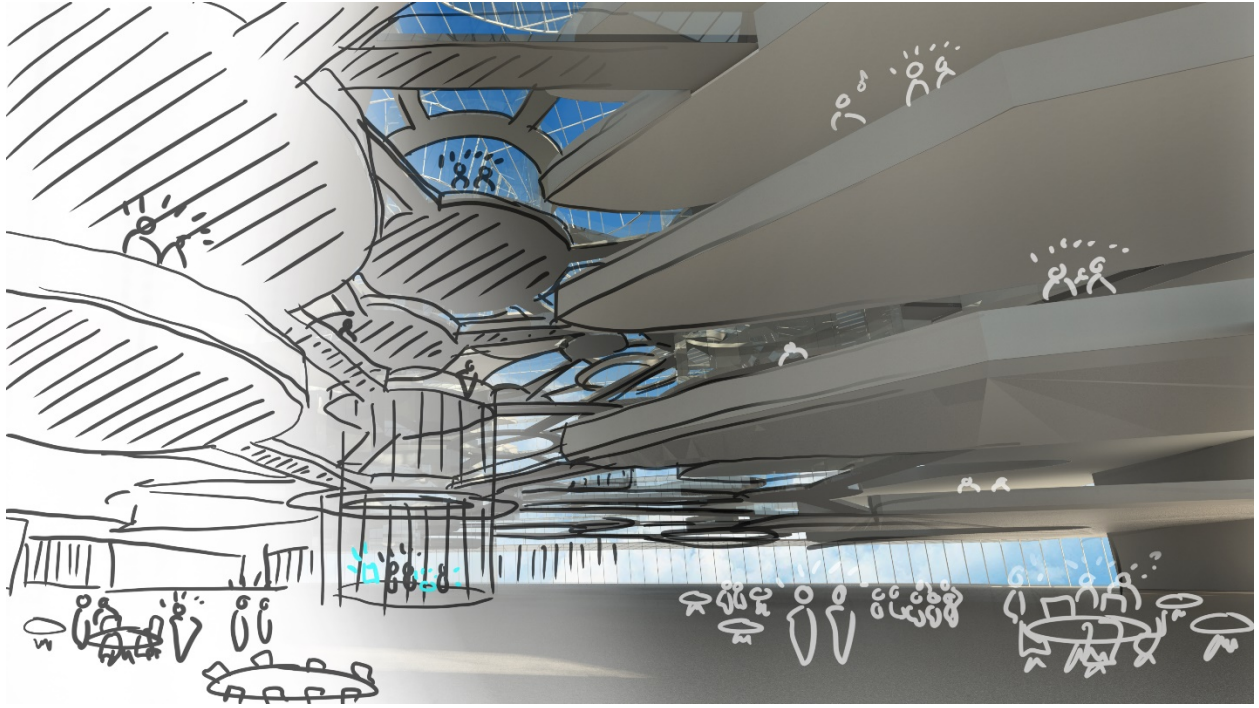

Figure 37 Interior Render E

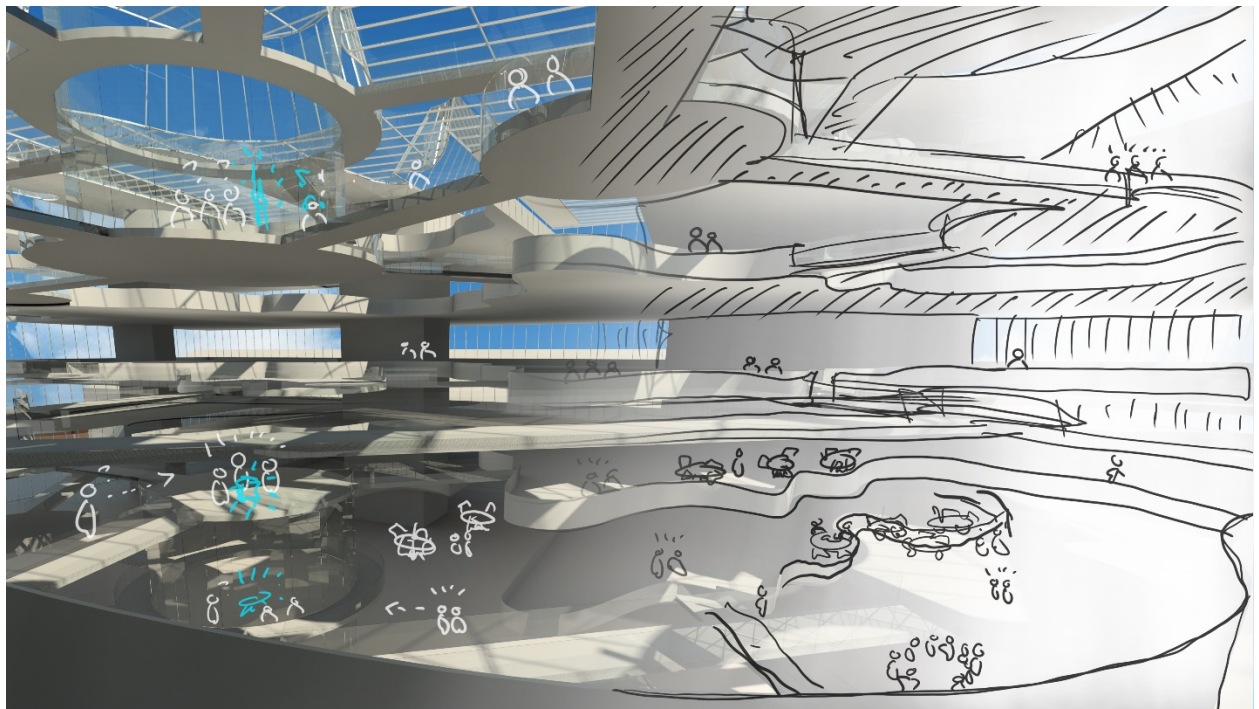

Figure 36 Interior Render F

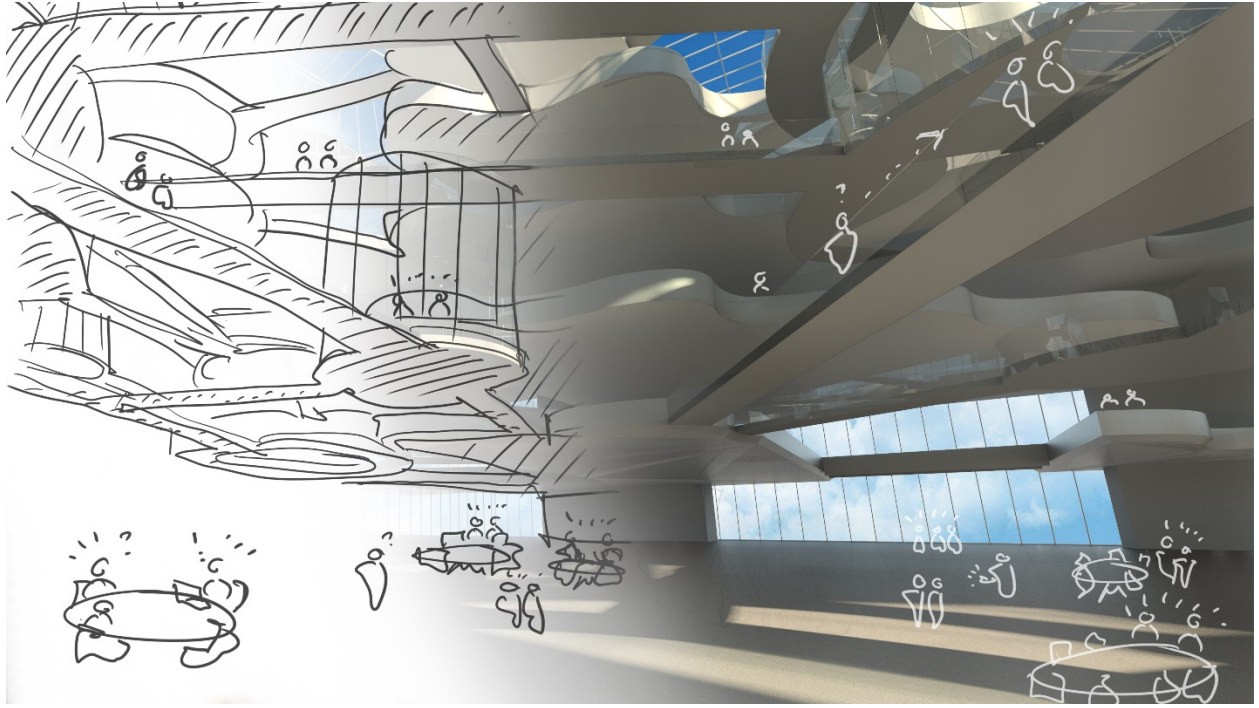

Figure 38 Interior Render G

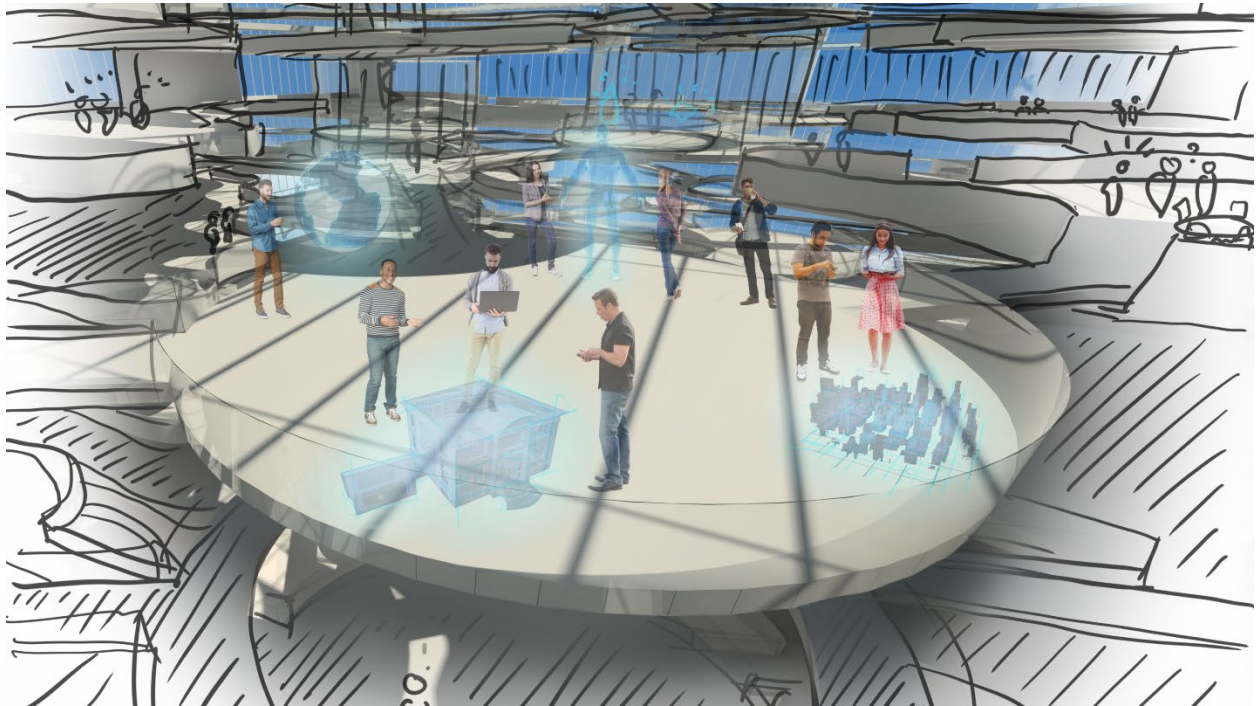

Figure 39 MINDLAB

## VI. CONCLUSIONS

This school for interdisciplinarity was a process-oriented project that allowed me to conceptualize what I think is important for the future of design. The project itself was less of a meticulously designed building that attempts to put on airs or pretense, and more of a first crack at what architecture can do to better educational environments. I don't necessarily believe this project is the perfect example of this, nor does it attempt to be some form of typological manifesto for designers to follow by the book. The design is an example, a crystallization of theory and research as space for the cultivation of a way of learning, a way of thinking. MINDLAB is representative of how we can start to think about new technologies and exciting advancements as a source of aid and support for new systems in education, and beyond that, the school itself is a good starting point for how we as designers can think about and talk about architecture as well, for a more adaptive, reactive future.

The process, on the other hand, was an intensely personal exercise in interpretation and distillation of my own thoughts and feelings and ideations in respect to my research. While the process is not intended as a handbook for other designers, the intent is to frame a way of thinking. It is interpretive, reactive, and at its core, interdisciplinary. If this kind of idea was embraced, seeking inspiration across disciplines, learning about different ways of thinking and practicing professions, growing as a person from not only our own experiences, but from those of others as well, the human species would open and maintain a much stronger interdisciplinary dialogue.

In the end, the thesis returns to my diagram for the school of interdisciplinarity.

Change, like evolution, is a slow process of attrition, of incremental exposition, reaction, adaptation, and growth. We are siloed and fractured by identity, belief systems, philosophies and ideals, concepts, culture, and history.

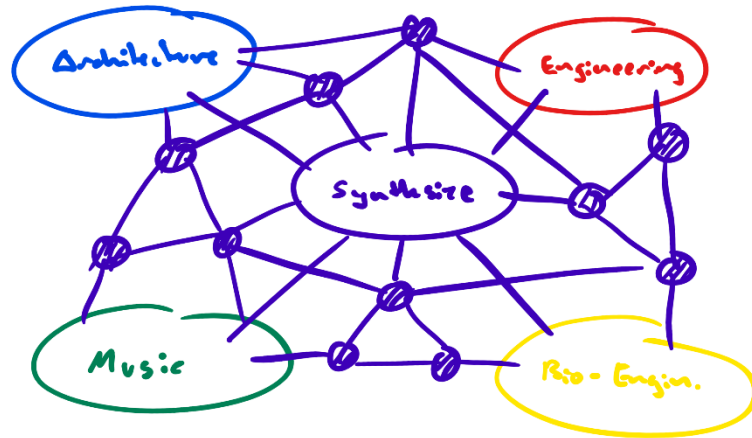

Figure 40 Interdisciplinary Network

This truth will not disappear

simply by recognizing it, and it will not be erased or broken down in immediacy or haste. We live within a contemporary society, where urgency has bred hopelessness in the face of how slowly change takes place.

In the face of all of this, I like to believe that this system presents hope; that if we can begin to network these silos in a more effective way than a simple cross-pollination or relating of ideas, the inevitability of change will follow. We need to cultivate this kind of philosophy, ingrain a demand and need for investment and adaptation within a culture so dominated by short-sighted success and gain. It will not only benefit the way that professions interact, but it will eventually plant the seeds of how we can break down other barriers as well. Understanding why things are the way they are, and recognizing where the disconnects and problems are centered, allows for a more targeted approach to change and growth.

Embracing diversity of thought, just as in genetics, will form a much more stable foundation for human thought, and will bear forth innovation.

## WORKS CITED

*Mimesis: The Representation of Reality in Western Literature*, Erich Auerbach, Princeton University Press, 1953/2003

*The Most Human Human*, Brian Christiansen, First Anchor Books Edition, February 2012

*The Selfish Gene*, Richard Dawkins, Oxford University Press; 4<sup>th</sup> Edition, August 1, 2016

*The Mirror Stage as Formative of the Function of the I as Revealed in Psychoanalytic Experience*, Jacques Lacan, 1946, Trans. By Alan Sheridan

*What is Darwin's Theory of Evolution*, LiveScience, Ker Than February 28<sup>th</sup>, 2018  
<https://www.livescience.com/474-controversy-evolution-works.html>

*Darwin's Theory of Evolution*, BBC GCSE Bitesize, BBC 2014  
[http://www.bbc.co.uk/schools/gcsebitesize/science/edexcel\\_pre\\_2011/environment/evolutionrev4.shtml](http://www.bbc.co.uk/schools/gcsebitesize/science/edexcel_pre_2011/environment/evolutionrev4.shtml)

*Erich Auerbach*, Encyclopedia Britannica, Nov. 5<sup>th</sup>, 2018  
<https://www.britannica.com/biography/Erich-Auerbach>

*Memetics: Definition*, Merriam-Webster Dictionary  
<https://www.merriam-webster.com/dictionary/memetics>

*Memetics: Definition*, Principia Cybernetica Web, F. Heylighen, Nov. 23, 2001, Mod.  
<http://pespmc1.vub.ac.be/MEMES.html>