

StartUp: Reinventing the Live/work Highrise to Foster the Incubation + Growth of Seatt's Startups

Matthew Fuhr

A thesis

submitted in partial fulfillment of the
requirements for the degree of

Master of Architecture

University of Washington

2015

Committee:

Brain McLaren

Nina Franey

Program Authorized to Offer Degree:

Architecture

© Copyright Matthew Fuhr

ABSTRACT

StartUp: Reinventing the Live/work Highrise to Foster the Incubation + Growth of Seatt's Startups

Matthew Fuhr

Chair of the Supervisory Committee:

Associate Professor Brian McLaren

Architecture

Problem

The current live/work typologies create isolation and do not address the needs of Seattle's growing number of freelancers, entrepreneurs, and startups whose success depends on interaction, affordable living, and small scale office space.

What ought to be

In many surrounding neighborhoods small scale coworking office spaces, live/work apartments, and startup incubators have found success.

Thesis Proposition

A new live/work high rise typology in Belltown Seattle could provide affordable spaces for entrepreneurs and startups. By using coworking office space and an incubator equity model to subsidize rental costs for apartments, this thesis aims to redefine the live/work typology to create a community of collaboration through interaction that fosters the success of existing small businesses and conceives new startups.

START UP

Reinventing the live/work highrise to foster the
incubation + growth of Seattle's startups

CONTE

NTS

IMAGES	08
PREFACE	10
CHAPTER 01 problem	14
CHAPTER 02 framework	26
CHAPTER 03 methodology	32
CHAPTER 04 findings + design	50
CHAPTER 05 conclusion	89
SOURCES	90

FIGURES

all figures generated by author unless noted

- 01** Startup Company Logos *<https://www.rocket-internet.com/companies>*
- 02** Seattle Startup Numbers *data from Geek Wire and Startup Genome*
- 03** Startup Challenges Statistics *data from inc.com, the Kaufman foundation and Compass*
- 04** Seattle Coworking Offices *data from Deskmag*
- 05** Seattle Apartment Costs *data from Rent Jungle, Seattle PI and the city of Seattle*
- 06** Startup Communities and Ecosystems
- 07** Live/Work Typology Comparison
- 08** Live/Work Comparison
- 09** Theoretical Framework
- 10** Idea 1 Precedent Images *<http://www.ideadistrictsd.com/idea1/>*
- 11** Google Precedent Images *<http://www.archdaily.com/232170/google-campus-jump-studios/>*
- 12** Nagatino 2.0 Precedent Images *<http://www.archdaily.com/492456/nagatino-2-0-coworking-center-ruslan-aydarov-archietcture-studio/>*
- 13** Seattle's Corporate Skyline
- 14** Target Area Selection Map
- 15** Key Adjacencies Map
- 16** Site Location Map
- 17** Site Context Maps + Diagrams
- 18** Corporate VS Human Scaled Diagram
- 19** Vertical Neighborhood Diagram
- 20** Diversity Diagram
- 21** Flexibility Diagram
- 22** Potential Membership Packages Infographic
- 23** Membership Package Percentages Infographic
- 24** Scales Diagram
- 25** Block and Pod Diagrams
- 26** Transportation Diagram
- 27** Interaction from Circulation Diagram
- 28** Form evolution Diagrams

FIGURES CONT.

all figures generated by author unless noted

- 29** North Section Illustration
- 30** East Section Illustration
- 31** Community Commons Facade Illustrations
- 32** Coworking Office Space Facade Illustrations
- 33** Residential Facade Illustrations
- 34** Podium Facade Illustrations
- 35** Night View Illustration
- 36** View from Columbia Tower Illustration
- 37** Block and Pod Axon Diagrams
- 38** Pod A Floorplans
- 39** Pod B Floorplans
- 40** Block Section Illustration
- 41** Startup Life Micro Unit
- 42** Startup Life Commons Kitchen
- 43** Startup Life Public Marketplace
- 44** Startup Life Commons Flex Space
- 45** Startup Life Sky Park
- 46** Startup Life Outdoor Lounge
- 47** Startup Life Dedicated Workspaces
- 48** Startup Life Commons Flex Space
- 49** Startup Life Conference Room
- 50** Startup Life Commons Cafe
- 51** Startup Life Micro Unit
- 52** Startup Life Skyline

PREFACE

With both of my parents having their own businesses the subject of entrepreneurship and live/work housing is of personal interest to me. I grew up in a household that had my father's' electrical engineering practice in the basement. He employed 8 engineers and office staff so our household was always active with people coming and going throughout the day. Everyday after school I would be able to see and spend time with my father which is something that has been growing increasingly more rare in our modern society. Because of his constant availability, my father and I have a close bond and his lifestyle has inspired me to create my own business, SEA 206 Clothing which to this day I run and operate out of my tiny 450 sq ft apartment in the University District.

With my apartment rent being so high, I unfortunately am unable to afford a desk at a coworking office. As a result I work in isolation from my "urban one bedroom" apartment in an environment that is not conducive to creativity or success. From my experiences of living and working in standard market rate apartments I have

found that developers and architects are not designing to address the needs of small startups, entrepreneurs and freelancers.

01

PROBLEM

INTRODUCTION

Current Problem

Over the last decade with the advances in technology more and more people have begun starting their own business or working from home. In addition many creatives such as artists, graphic designers, coders, web designers, and photographers typically work part time from home for larger companies as contract employees. While the workforce and the way people work has changed the office environment in which they work has not. The rising cost of office space and housing in downtown has forced many of these entrepreneurs, creatives and startups out of Seattle's central business core and into the surrounding neighborhoods where they are often disconnected and isolated from the services and collaborative environment they need for their business to thrive. The current live/work typologies that do exist in downtown Seattle, create isolation and do not address the needs of Seattle's growing number of freelancers, entrepreneurs, and startups whose success depends on interaction, affordable living, and small scale office space.

Potential Solution

Coworking is a proven concept that has been shown to be popular amongst small businesses and entrepreneurs. Likewise developers have found that by converting to coworking space and charging by head or desk they can generate more revenue per square foot than a comparable lease on spec office. Startup incubators have also been proven to be successful in developing new thriving businesses as well as providing a return on investment.

Thesis Proposition

This thesis proposes A live/cowork/interact high rise in Belltown Seattle that could provide affordable spaces for entrepreneurs and startups. By using coworking office space and an incubator equity model to subsidize rental costs for apartments, this thesis aims to redefine the live/work typology to create a community of collaboration through interaction that fosters the success of existing small businesses and conceives new startups.

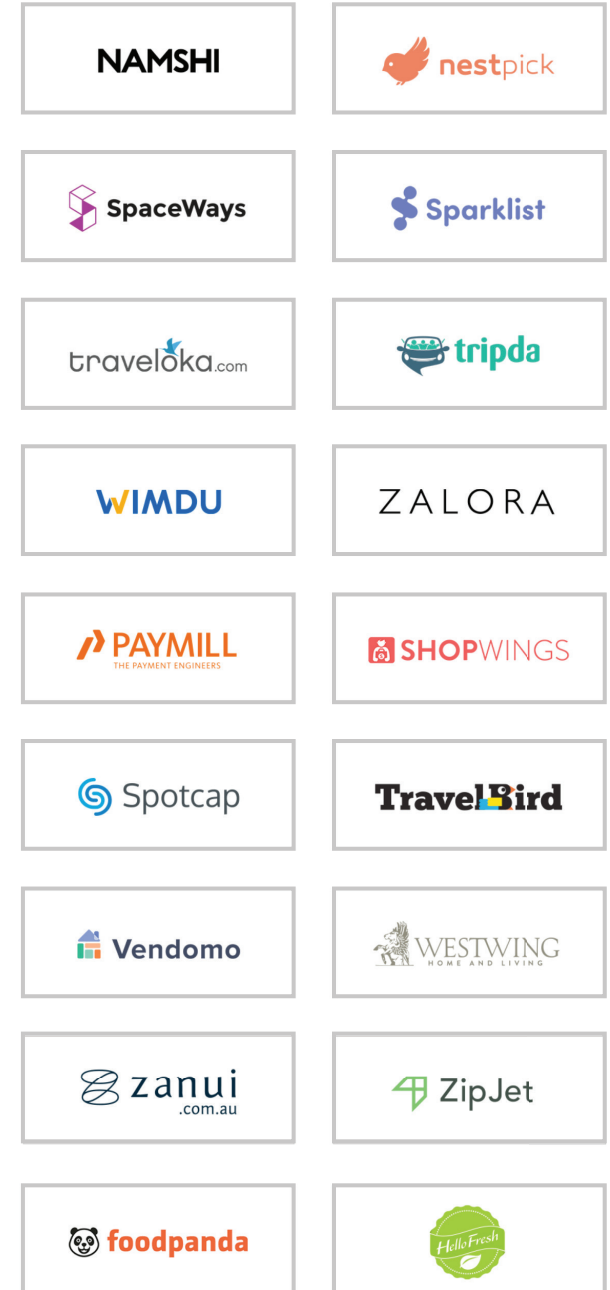

Figure 01: Startup Company Logos

DEMAND

Seattle a Rising Startup Superpower

According to Startup Genome, Seattle now ranks 4th in the world as a global startup hub (Cook). With the huge expansion of companies such as Amazon, Facebook, Tableau, Microsoft, and Alibaba, Seattle has become a hot bed for young tech savvy talent. South Lake Union is growing into the next Silicon Valley according to techcrunch which states that, " Seattle tech scene is demonstrably different than just seven years ago." Even back in 2008 Glenn Kelman of Redfin wrote that Seattle would be "the next Silicon Valley," reports techcrunch (Partovi). This is partly due to the fact that Seattle has one of the highest populations of software engineers and developers. Techcrunch states that "In fact, Washington State is one of only 4 states where the most common job occupation is "software developer" (the others are Virginia, Colorado, and Utah)" (Partovi). The Seattle/Bellevue/Everett metro area even has more software developers than Silicon Valley, the San Jose/Sunnyvale/Santa Clara metro area according to data from the Bureau of Labor Statistics. While

Startups continue become a larger part of Seattle's economy how can we create an environment to foster their formation and growth?

Shift to Contract/Freelance Employees

Tech Companies such as Amazon and Microsoft have also changed the way they hire new employees. Contract employees are becoming more common in Seattle because it allows tech companies to scale up and down more fluidly for large projects. According to a 2010 Intuit study, 40 percent of Americans, or 60 million people, will be independent contractors or freelancers by 2020 (Intuit). Many contractors working in Seattle are web developers, software engineers, photographers, sales representatives, and graphic designers. These contractors often work part time and work from home or coworking office spaces doing freelance. According to the Seattle Times, "Co-working spaces provide a low-cost option for start-ups and freelancers who may not always want to work alone at home in their pajamas" (Tan).

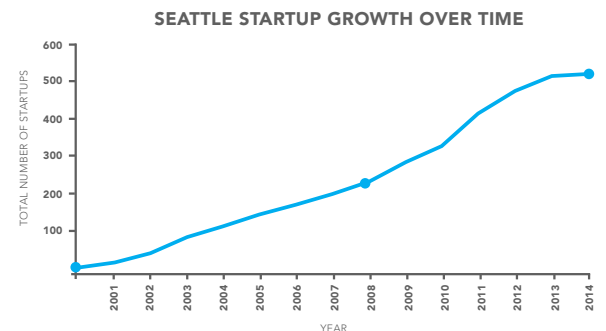
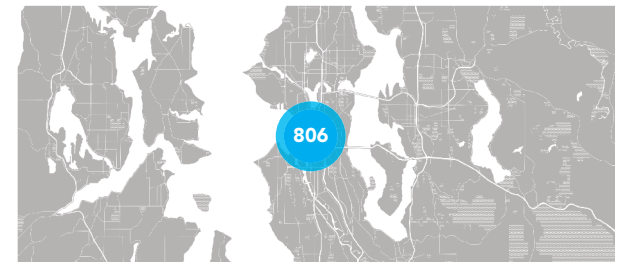

Figure 02: Seattle Startup Numbers 15

DEMOGRAPHICS

Who makes up a startup?

The word “startup” refers to internet based young businesses that are often invested in by venture capitalists or seeking investment from venture capitalists. These business are stereotyped as young college grads living off of top ramen but in reality over half of them are between the ages 35-44 according to the 2010 CB Insights Venture Capitalist Human Capital report (Shah). In addition the Kauffman foundation for entrepreneurship found that 59.7% of startup founders had one or more child at the time they started their business(Shah).

NEEDS

Affordable workspace and housing

With the growing number of new startups, contract employees, freelancers, and entrepreneurs, issues of affordable work space and housing have become important to their long term success. Many small businesses are not profitable in their first year and under normal circumstances 75% of new businesses fail (McDermott). With these risks affordable office space and

housing are crucial for small businesses and startups to maintain low overhead and operating costs. In addition, flexibility and short term leases are essential for the scaling up or down a startup that is in its infancy.

Community of Collaboration

The environment in which a startup or entrepreneur operates in is equally essential to financial success of a business. A strong community of other professionals can help small businesses and startups to network and make valuable business connections. From an environment that harnesses community and collaboration new ideas can be created and businesses can improve their products, services, and ideas.

Location and Services

Location and services are also important factors in the growth of startups. Technology based startups rely on access to servers and high speed fiber optic internet for web based developments.

75% of venture backed startups will fail - inc.com

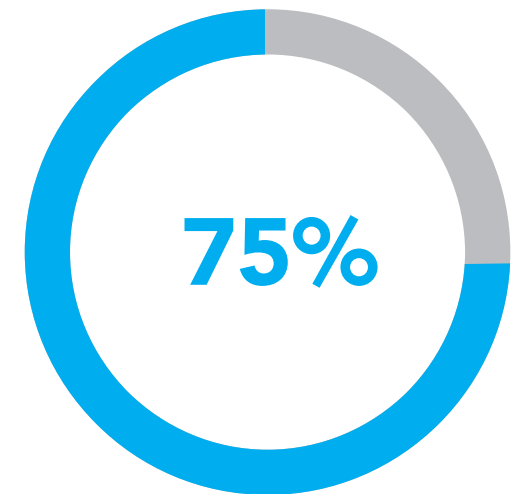
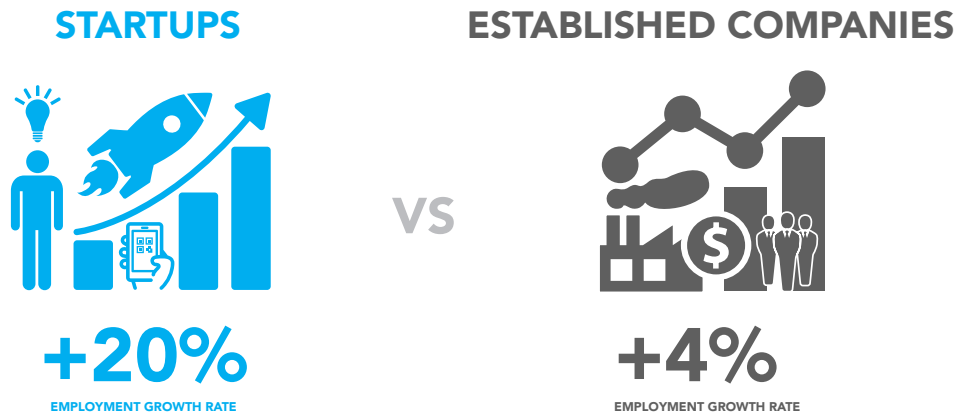

Figure 03: Startup Challenges Statistics

Business startups that survive grow faster than more established companies - BDS data funded by the Ewing Marion Kauffman Foundation



73% of Entrepreneurs and startup founders receive a salary of \$50,000 or less a year - compass

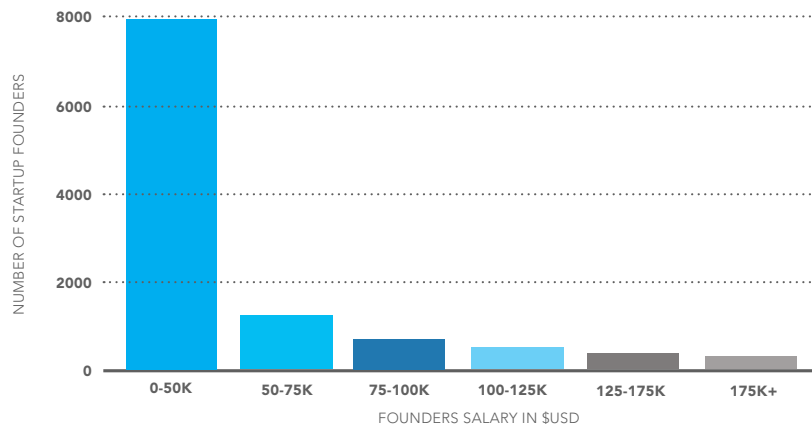

Figure 04: Seattle Coworking Offices

NEEDS CONT.

Public transportation, visibility, proximity to other businesses, physical presence, and a diverse employee base make downtown the prime location for startups and small businesses. Patrick Stonelake, Chief Growth Officer at Fruition Partners explains that:

“An office in the heart of a city has an attraction that simply can’t be replicated in an office park by the airport. In a growing business, your ability to distinguish yourself is key. Are you unique, growing, vibrant, diverse, exciting? Or are you beige, well-trimmed and safe? What says more about you than where you choose to set up shop?” (Forbes Entrepreneurs).

Due to the needs of the growing number of startups and small businesses in the region downtown Seattle is best suited for creating an environment of cultivation for startups. Providing affordable office space and affordable housing for startups and entrepreneurs in downtown could help foster and create prosperity.

COWORKING OFFICES

With such high demand, small scale office space in downtown is nearly impossible to find for most startups, entrepreneurs, contract/freelance employees. Most office buildings do not cater to sole proprietorships and small business needing only one or two desk spaces. In the central business district of Seattle there is only one coworking office that can accommodate small businesses. Most of the larger coworking office spaces are located in outlying neighborhoods such as Ballard, Fremont, and Capitol Hill. According to Jacob Sayles of the cofounder of Seattle Collaborative Space Alliance, "Even if Seattle had 50 coworking spaces, we wouldn't be anywhere near capacity" (Guzman).

Coworking office space in Seattle is relatively affordable for small businesses. WeWork, the largest coworking office in Seattle charges \$375 a month for a dedicated desks and \$550 a month for private offices (WeWork). This also includes amenities such as lounges, high speed internet, community managers, free beer, purified water, printing, conference rooms,



**ONLY 16 COWORKING OFFICES
NEAR DOWNTOWN SEATTLE**

"Even if we had 50 coworking spaces we wouldn't be anywhere near capacity." - Jacob Sayles Collaborative Space Alliance

micro-roasted coffee, and private phone booths. In comparison to standard office space the price is far more affordable and there are greater amenities for the price. According to deskmag, "In the United States, a coworker pays an average of \$365 a month for a desk with normal office infrastructure and 24-hour access.

Comparatively, a desk in a typical office costs \$733 on average" (Foertsch).

COWORKING **\$375_{mo}**

SPEC OFFICE **\$733_{mo}**



vs



1-2 mo

3-5 yr

Figure 04: Seattle Coworking Offices

AFFORDABLE UNITS

While small scale office space is scarce in downtown Seattle, apartment units are decreasing in size making it more difficult to work from home. New development in Seattle has almost exclusively built one bedroom and studio units as developers try to maximize the amount of units in their buildings. These smaller “tucked one bedroom” units do not have windows for their bedrooms and can be as small as 450 sq ft. This makes it an undesirable environment for any entrepreneur who is thinking about working from home. According to Gardner Economics, the average size of one bedroom units has fallen by 20% since 2001 (Gardner).

Rent for apartments in Seattle have been increasing at a fast rate making many apartments in downtown unaffordable. For entrepreneurs hoping to work from home the average cost of a one bedroom apartment in Seattle that was constructed after 2010 is \$1,700 a month and roughly \$2.40 per sq ft. according to Gardner Economics (Gardner). Apartments rates are also continuing to climb at a rate of 11% a year according to Rent Jungle.

Because of these increases the average renter in the Seattle Bellevue Metro area can now only afford a studio apartment according to the National Low Income Housing Coalition’s annual “Out of Reach” report (National Low Income Housing Coalition). This high cost of living means that many entrepreneurs who want to

work from home will not be able to afford to do so in downtown Seattle. This creates a situation where freelance workers and small business owners cannot feasibly do business in the city where they have the necessary resources, connections, and community to thrive.

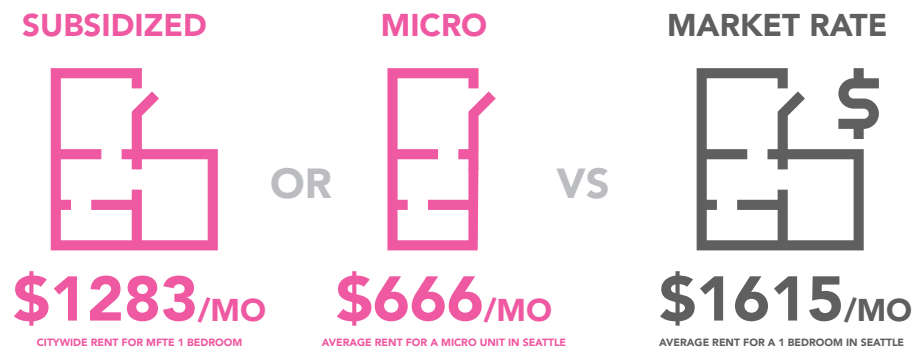
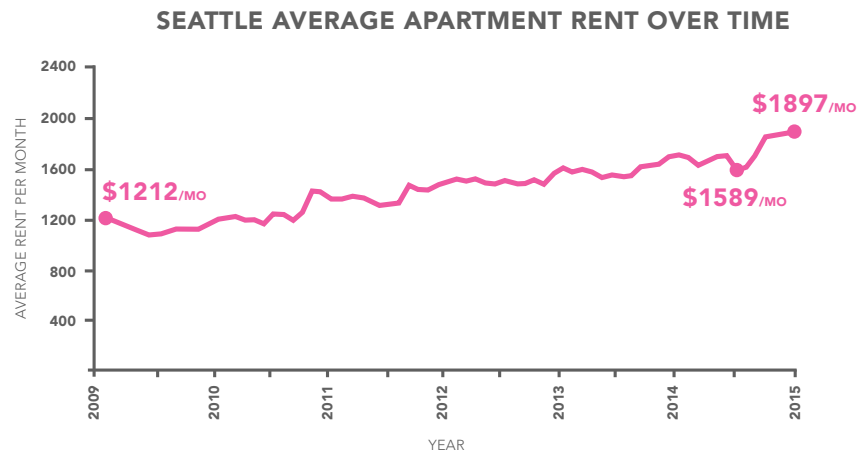

Figure 05: Seattle Apartment Costs

COMMUNITY

Coworking community collaboration

With the growing number of startups, small businesses, and contract employees, small scale office space has been scarce and in high demand. Coworking in essence is flexible open office space shared with other freelance or self employed individuals where you pay to rent a desk on a monthly basis. According to Coworking Wiki:

“Coworking is redefining the way we do work. The idea is simple: that independent professionals and those with workplace flexibility work better together than they do alone. Coworking answers the question that so many face when working from home: “Why isn’t this as fun as I thought it would be?” Beyond just creating better places to work, coworking spaces are built around the idea of community-building and sustainability. Coworking spaces agree to uphold the values set forth by those who developed the concept in the first place: collaboration, community, sustainability, openness, and accessibility” (Coworking Wiki).

As a result, many small coworking offices have opened up in Capitol Hill, Ballard,

Pioneer square, and South Lake Union. Because of the diversity of occupations, coworking offices encourage collaboration between users and enables them to share skills and knowledge. From these interactions entrepreneurs can make new business connections and even form new business ventures. The latest and largest coworking space in Seattle is WeWork’s 55,000 sq ft, 3 story coworking office in South Lake Union. The Office is expected to house nearly 800 workers at long shared tables, private offices, and team rooms.

Live/Work communities

Live/Work housing is an old typology that provides affordable units that are large enough for people to live and practice their careers. Recently the idea has been modernized to accommodate the needs of small businesses and startups looking for affordable space. As Roger Vincent of the LA Times Explains, “ in recent years, work-at-home entrepreneurs are taking a giant step out of their home offices in suburban neighborhoods and into “live-work” units in commercial and industrial

areas once practically vacant after 6 p.m” (Vincent).

Many of these live work housing units are built in old warehouses that have high ceiling and storefronts. A common typology is the 2 story live/work loft where the ground floor is a retail store or office and the 2nd level is the residence. These units provide many advantages over the typical home office and working from a dedicated office. Jeffrey Joyner wrote in the small business chronicle,

“live-work unit cuts your commute time to seconds, and because all you need to do is walk from your bedroom to your office, you avoid the cost of gasoline for commuting to work. You do not have to brave scorching summer heat, torrential spring rains or bitter winter snows to go to work. Lunch can be a healthy, inexpensive meal prepared in your own kitchen rather than a rushed, expensive affair at a crowded restaurant. A live-work unit offers similar advantages to a home office, but it is often easier to prove your deductions to the Internal Revenue Service for a live-work unit than a home office” (Joyner).

“It’s my belief that vibrant startup ecosystems will create more successful startups, which lead to more startups.”

- Scott Case, CEO of Startup America Partnership

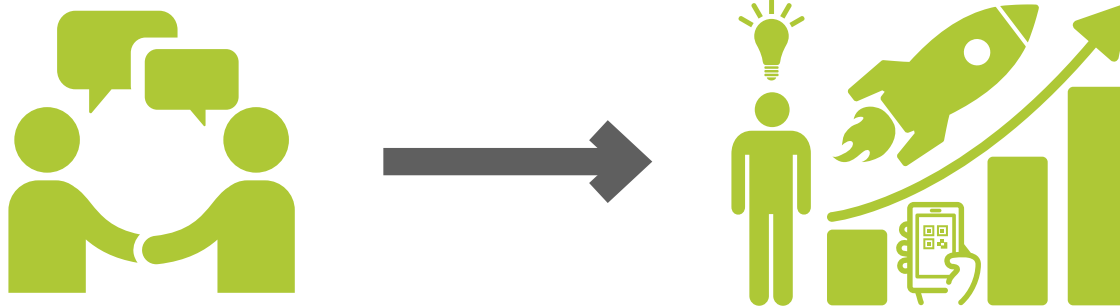

INCUBATOR MODELS

In addition to coworking offices, the incubator model has been proven successful for many of its sponsors and startups. Incubators have been around since the 1950’s but “Now a new breed of incubator, catering mainly to technology types, is springing up all over the country. These startup hubs offer expert mentorship, resources like office space and legal counsel, and even seed money—typically in exchange for a small amount of equity in tiny (or theoretical) companies.” According to J.J Colao of Forbes Magazine (Colao).

These new incubators provide affordable or free office space and help nurture and grow new business ventures. These Incubators have also been proven to increase a startups chance of success with eighty seven (87%) percent of firms that graduated from incubators since inception were still in business, according to an NBIA ‘Business Incubation Works’ Report (NBIA). As a result, many institutions, corporations, and universities are creating their own incubator programs to cash in on new startups.

Figure 06: Startup Communities and Ecosystems

PROBLEM / SOLUTION

Seattle is a city that is at the forefront of innovation and has risen to be ranked the 4th best startup hub in the world. The number of startups, small businesses, and freelancers in Seattle is growing at a fast rate. However, developers have failed to address the needs of the changing work environment.

More and more small business are looking to move downtown for the community of collaboration and location yet there is not enough available and affordable office space or housing for them. Coworking provides a solution to their need for affordable small scale office space yet there are only a few offices available in the city and many are fully leased and have waitlists to join. This thesis proposes a large scale coworking and incubator live/work tower as the solution to this growing problem in downtown Seattle.

**MARKET RATE
APARTMENTS**

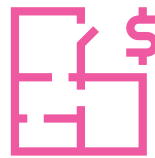

**OUTDOOR
AMENITIES**



**LARGE SCALE
OFFICE SPACE**



VS

**SUBSIDIZED
APARTMENTS**



**STARTUP
COMMUNITY**



**COWORKING
OFFICES**



THE TYPICAL LIVE/WORK TOWER TYPOLOGY

THE REINVENTED LIVE/WORK TOWER TYPOLOGY

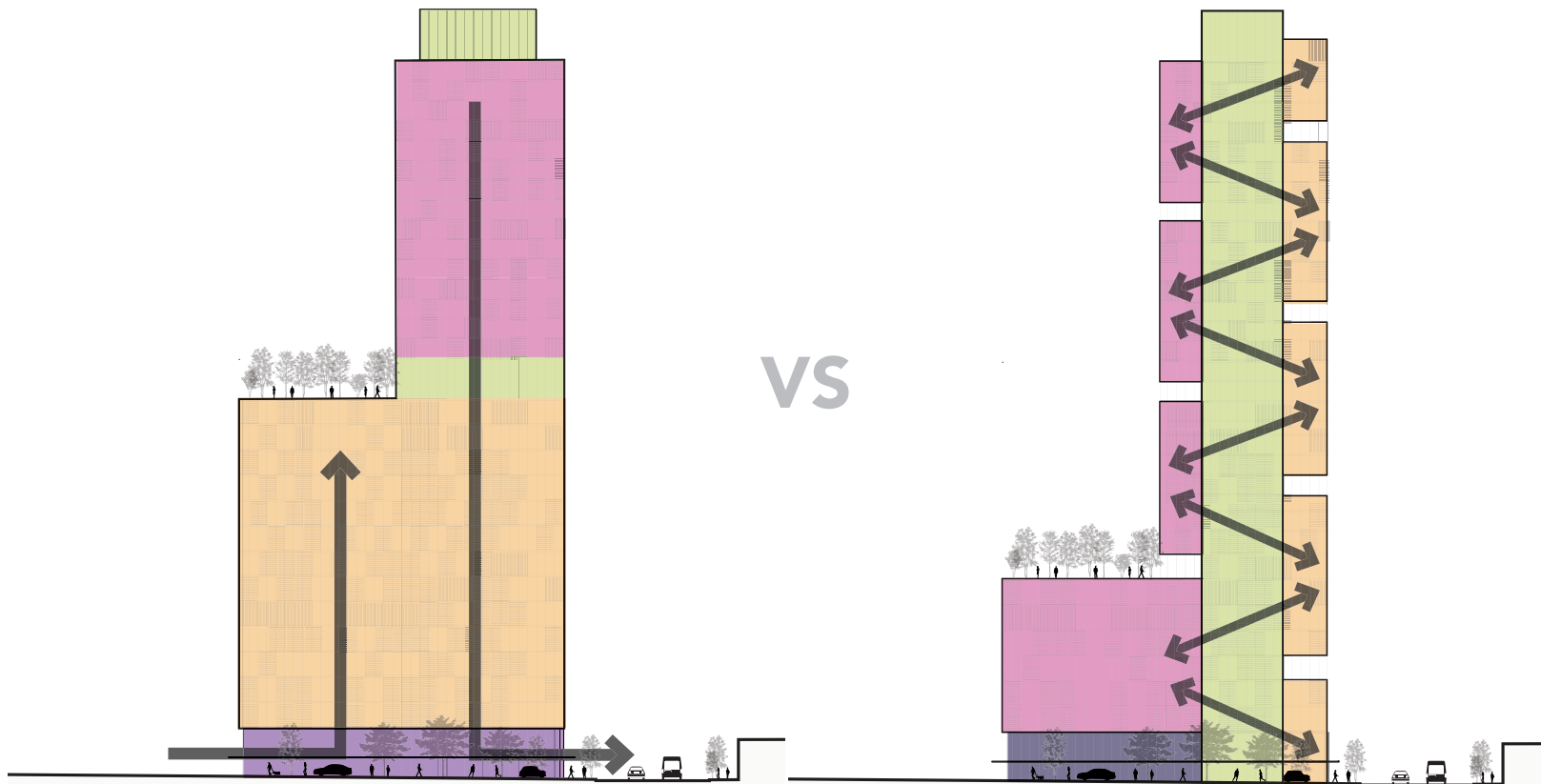

Figure 08: Live/Work Comparison

02

FRAMEWORK

THEORETICAL FRAMEWORK

The theoretical framework for the thesis draws upon a holistic approach to solving the problems that face many small businesses and entrepreneurs. By redefining the live/work highrise typology the thesis can address the needs of

startups such as the need for affordable housing and apartments, community and a startup ecosystem, as well as short term and small scale office space. Through an investigation of existing solutions and precedent projects it was identified that

3 key program elements could address these needs. Micro units and subsidized apartment units, a community commons, and coworking office space if combined in the right way could address the problems facing Seattle's startups.



PRECEDENT STUDIES

In selecting precedent projects to analyze it was important to not be fixated on the highrise typology but instead to find projects that were at the appropriate scale. The startup highrise is trying to break down the tower scale into a network of smaller scale interdependent communities that capture the essence of many of the small coworking offices already in existence. As a result, the precedent project selected range from 2 level to 6 level projects and vary in their financing structure. The first project, idea 1 is a commercial development with market rate apartments and a separately ran coworking office. The second is an incubator which is funded by Google to help new young talent develop their ideas in exchange for equity in their businesses. The third uses the typical coworking office model where space is leased from a building and then furnished and marketed to small businesses. All three of these precedent studies help inform design decisions and financing options for the proposed highrise which is intended to be developed, managed, owned and operated by a joint venture between a developer and large coworking company like WeWork.

IDEA 1 / MILLER HULL

According to IDEA 1:

"IDEA1 helps establish the District's vision of becoming San Diego's design + technology innovation hub. We will achieve this goal by mixing all of the critical uses – office, residential, and retail – in a way that encourages interaction between inhabitants of this block and the larger community.

San Diego is competing in the most important race of the 21st Century: the race for talent. We define talent as highly educated, highly mobile 24-35 year-olds who are tomorrow's workforce and entrepreneurs. They are essential ingredients for an innovation economy – equally important for the City as for local businesses. IDEA1 will attract the best and the brightest in the world by offering them what they want: an urban, walkable community rich in amenities (Idea 1)."

CREATIVE OFFICE SPACE

8,000+ sf on ground floor
Designed for design and technology

28



STARTUP HOUSING

295 units
Studios and 1 and 2-bedrooms

RETAIL SPACE

5,000 sf at street level
Potential craft beer pub or maker space

COMMUNITY HUB

Connects residential and commercial uses
Hosts events such as meetups, art fairs
hackathons, panels, and presentations.

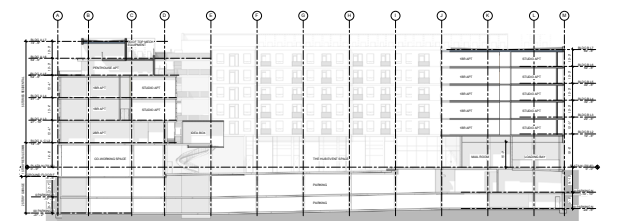

Figure 10: Idea 1 Precedent Images

GOOGLE / JUMP STUDIOS

According to Google Campus:

"Google Campus is a seven storey co-working and event space in the centre of London's Tech City, otherwise known as Silicon Roundabout. The project, run by Google UK aims to fuel the success of London's tech start up community.

Working with partners Seedcamp, Tech Hub, Springboard and Central Working, the primary function of Campus will be to provide office space for startup companies, but the facilities will also host daily events, offer regular speaker series with leading technology and entrepreneurship experts, hold networking events and run a constant mentoring program where Google staff will share their experience and expertise with residents (Arch Daily)."

OPEN OFFICE SPACE

- 5 Levels of open plan office
- offer hot desks
- personal lockers
- video conferencing
- meeting booths
- micro kitchen



COMMUNITY AMMENITIES

- Coffee bar
- Cafe
- Workshop
- Halfpipe
- Patio
- 40 stall bike storage

EDUCATION

- Presentation room seating 140 people
- Individual



Figure 11: Google Precedent Images **29**

NAGATINO 2.0 / RUSLAN

According to Arch Daily Nagatino is a:

"Coworking space with total area of 603 sq.m on the top floor of a former furniture factory that was transformed into a 748 sq.m by the construction of four local platforms of welded metal volumes."

A spacious loft includes seven working areas for a total of 100 seats, an extensive coffee zone, mini-hostel with 5 beds, children's room, 3 bathrooms and 2 shower rooms. Managed to preserve a sense of open space and visually zoned space (Arch Daily)."



OPEN OFFICE SPACE

100 Seats

Shared bench desks

2 Conference rooms

Private Lockers

COMMUNITY AMMENITITES

Childrens room

Cafe

Lounge

LIVING

Mini Hostel with 5 beds

30



Figure 12: Nagatino 2.0 Precedent Images

03

METHODOLOGY

METHODOLOGY

As previously described, the existing live/work highrise typology creates isolation and does not address the needs of Seattle's growing number of freelancers, entrepreneurs, and startups whose success depends on flexible small scale office space, affordable housing, and interaction with the startup community. With the city of Seattle rapidly densifying, more and more old low rise brick buildings, which are often home to small businesses, are

being demolished. In their place new skyscrapers are being developed that will accommodate only large scale office tenants and the wealthy few who can afford high end market rate apartments. This is causing small businesses and startups to slowly be forced to the fringes of the city.

This thesis proposes to carve out a piece of the Seattle skyline for small business and startups by establishing a new live/work

highrise typology that is human scaled and takes spatial cues from the urban fabric. This new live/work high rise in Belltown Seattle could provide coworking offices, subsidized apartments, and a community of startups that cultivates the success of existing small businesses and conceives new startups. This new typology could serve as the framework for every new live/work high rises, not just in Seattle, but in every major city around the world.

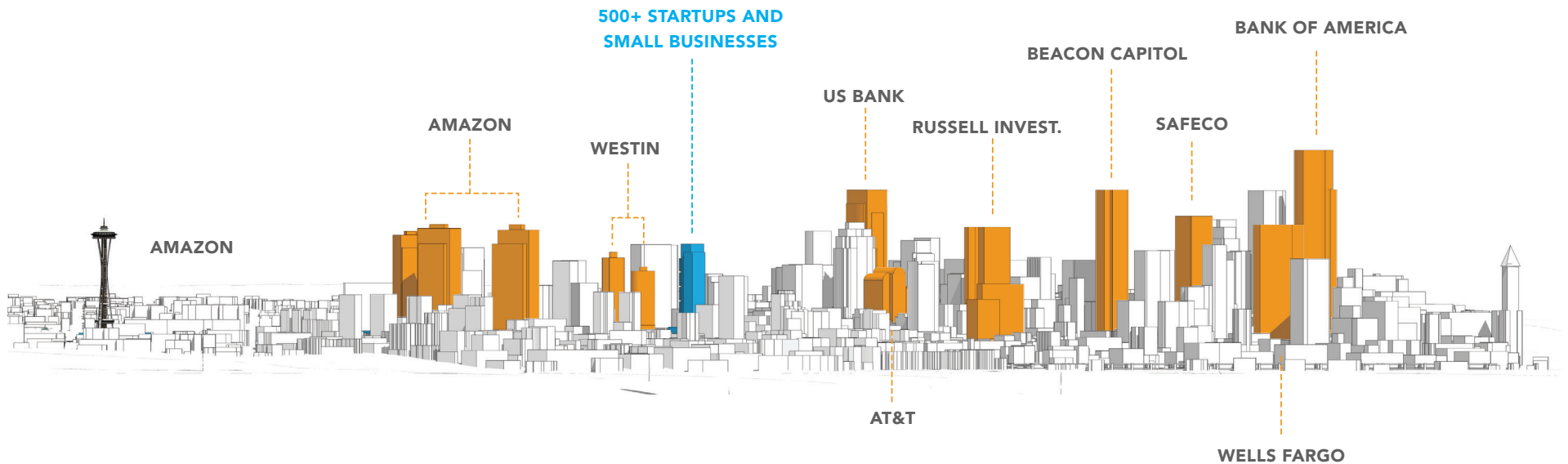

GOALS

This thesis intends to find a new and innovative arrangement of program elements to better foster interaction between users and establish a strong vibrant community of startups. In addition, the creation of a startup scaled highrise has the potential to take advantage of the synergies between programs and break down the scale of the highrise. Through the exploration of uses, scales, form, and interfaces, this thesis project aims to create spaces for small businesses instead of adapting existing spaces.

RESEARCH METHODOLOGY

The research for this thesis utilized both a positivist and constructivist approach when analyzing affordable housing, a physical startup community, and coworking office space. Early research indicated the number of startups in the Seattle area are growing at an extremely fast rate. In addition, it was identified that these startups face huge challenges such as financially insecure founders, isolation from their community, and rapid scaling up and down of their businesses. It became clear from this

research that to truly address the needs of entrepreneurs, who live for their work, it was essential that the project address both living and working. Upon learning of the isolation that startups face from not being able to afford to live in the city and seeing Seattle's skyrocketing cost of living it became clear that this project needed to redefine the live/work high rise typology. By investigating the economics of coworking office space and common space as well as micro units it became clear that the high revenue generation from users buying memberships to utilize the shared common areas could subsidize both the cost of the apartment units and dedicated workspace.

The design as a result, places shared commons areas at the heart of the project and serves as a connector between living and work. In addition these common spaces link together a series of outdoor spaces that modulate and breakdown the scale of the tower. Its essential for the success of the project that the design breaks down the scale of the highrise to promote a vibrant community, creates flexibility for

the expansion and contraction of families as well as businesses, and allows for a diversity of businesses.



Figure 14: Target Area Selection Map

TARGET AREA SELECTION

In addressing the lack affordable office space or live/work apartment units in downtown Seattle for the growing number of tech startups, contract employees, and entrepreneurs, Belltown, Downtown, SLU, and Pioneer square are all

potential target areas. With proximity to transportation, downtown business core, and South Lake Union being key factors the Belltown neighborhood appears to be the most practical location. The Belltown neighborhood is ideally located,

straddling both South Lake union and the Downtown business core. Belltown also is a very liveable neighborhood having a young demographic and key adjacencies to Pike Place Market, Amazon Rufus 2.0, and Westlake Shopping Center. Belltown

also has its own farmers market on Bell street and is well known for its night life making it desirable for both families and young entrepreneurs. This neighborhood has seen rapid growth over the past years as large tracts were recently up zoned from 200' to 400'. As a result many high

end residential towers have dominated the landscape. Belltown has become a neighborhood with very little office space despite its ideal location. With the predicted influx of Amazon employees this target area appears to be feasible for the construction of office/residential tower.



- PROPOSED SITE HUB FOR TRANSPORTATION + SMALL BUSINESS
- AMAZON HQ TECH EMPLOYMENT BASE + POTENTIAL NEW STARTUPS
- BELL STREET FARMERS MARKET AFFORDABLE VENDING OPPORTUNITIES
- PIKE PLACE MARKET ESTABLISHED LARGE VENDING + EXPOSURE
- WESTLAKE LARGE RETAIL OPPORTUNITIES + CONNECTIONS
- FINANCIAL INSTITUTIONS VC FUNDING AND SMALL BUSINESS LOAN SOURCES

Figure 15: Key Adjacencies Map

SITE SELECTION

With the neighborhood of Belltown rapidly expanding the few empty sites that are parking lots have already been proposed for development. Furthermore, many of the sites that have not been recently developed contain historically significant buildings. These two factors alone narrowed down the possible sites dramatically. Transportation and accessibility were also identified as important needs for many startups and small businesses. Belltown, however, does not have a light rail station nor transit tunnel stop so a site with adjacency to major bus lines is crucial for the success of the project. Near Belltown, the Bell street farmers market and Pikes Place Market could also provide opportunities for small product based companies to network and sell products in an affordable small scale setting. These farmers markets could help fuel the entrepreneurial community that is proposed. Because of this it is essential that the site be within walking distance of these two markets.

Based on the identified factors the site selected is on 3rd Avenue and Virginia

Street. It is currently an empty parking lot on the Southwest corner of the block. It is zoned to 290' non residential and up to 400' making it feasible to construct a large scale mixed use live/cowork community.

The site also has a major rapidride and King County Metro bus stop servicing the 1, 2, 3, 4, 5, 13, 14, 15, 16, 17, 18, 21, 24, 24, 26, 28, 29, 33, 40, 82, 116, 118, 119, 120, 124, 994, the D Line, and the E Line. With this large number and diversity of transit lines, the site location is major hub within the Belltown neighborhood. This also enables the site to have large amounts traffic supporting the potential for two story retail space. Furthermore, the site is located one block away from the 2nd avenue bike tracks which has become a major thoroughfare for bike commuters heading to and from the downtown business core. Overall the site is very accessible with multiple methods of alternative transportation making this an ideal location for entrepreneurs who may not be able to afford a car.



Figure 16: Site Location Map

Zoning Designation:

DMC 240/290-400
 Belltown Urban Center Village
 Seattle zoning map 109

23.49.058 Upper level development standards

Average residential floor plates are limited in size - limited to 10,000 SF (average) if tower is below 290' and limited to **10,700 SF** (average) if tower is above 290'. Maximum area of any residential floor is 11,500 SF.

Façade modulation is required and façade lengths are limited:

- 0-85' no limit
- 86-160' façade limited to 155'
- 161-240' façade limited to 125'
- 241-400' façade limited to 100'

Tower Width - Upper level width limit does not apply and residential tower is limited already by area limitation.

Tower separation - Tower separation does not currently limit the development of this site, and the neighbors to the North may develop towers in the future providing adequate separation.

23.49.008 Structure height

- 240' height limit for non-residential uses
- 290' height limit for residential use, without bonuses
- 400' height limit for residential use, with bonuses
- 440' height limit bonus for residential

- 10% height allowance for common recreation area and mechanical facades above 400' may not enclose an area greater than 9,000 SF. Unoccupied space for architectural interest is not counted as area.

23.49.011 Floor area ratio

Base of 5, maximum of 7 FAR basis is presumed to be computed on all lots on the block to west of alley FAR basis = 360' x 107' = 38,054 SF
 x 7 Max FAR = 266,400 SF Max FAR

Site 19,288 sq ft
Block 38,054 sq ft
FAR of 7 38,054 x 7 = 266,400 sq ft



RESIDENTIAL



Figure 17: Site Context Maps + Diagrams

PARKS + GREENSPACES



-  PARKS + COMMUNITY
-  PROPOSED SITE
-  5 MINUTE WALK RADIUS

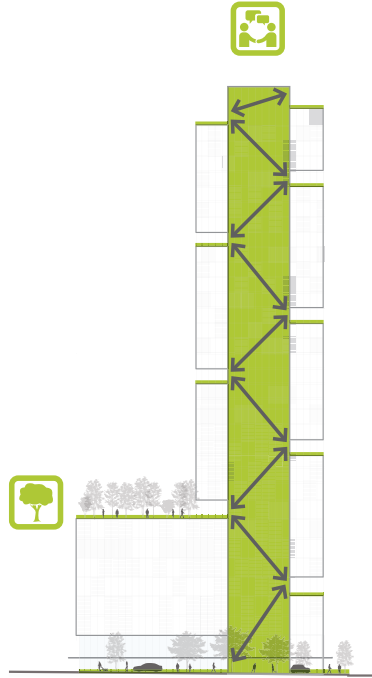

Figure 17: Site Context Maps + Diagrams

OFFICE SPACE



- OFFICE BUILDINGS
- PROPOSED SITE
- 5 MINUTE WALK RADIUS

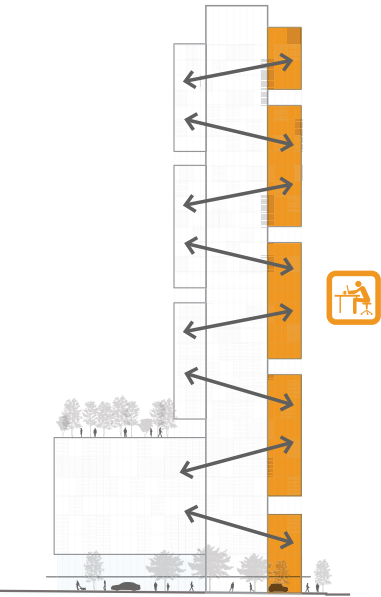

Figure 17: Site Context Maps + Diagrams

RETAIL + PUBLIC MARKETS

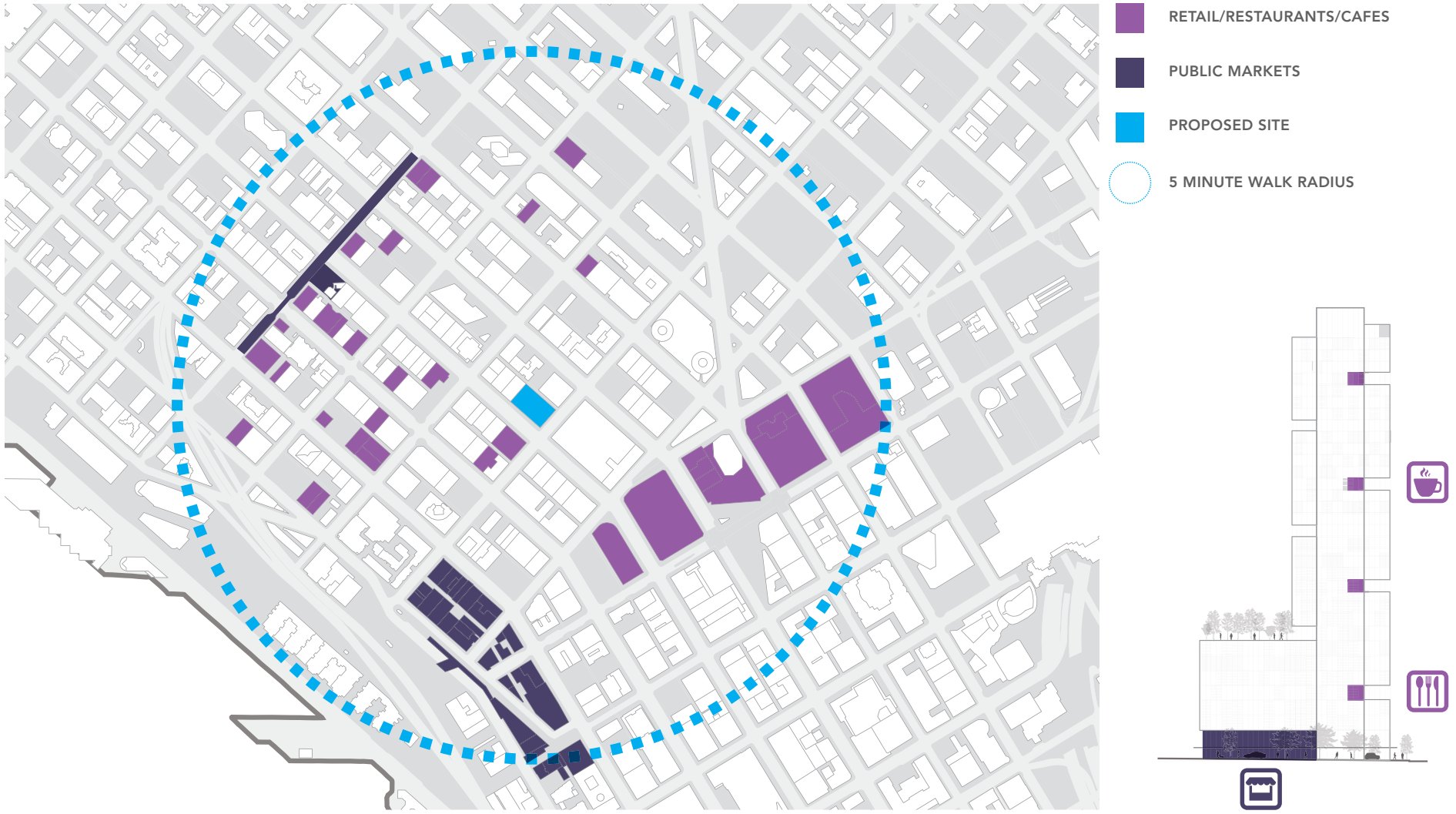

Figure 17: Site Context Maps + Diagrams

CIRCULATION

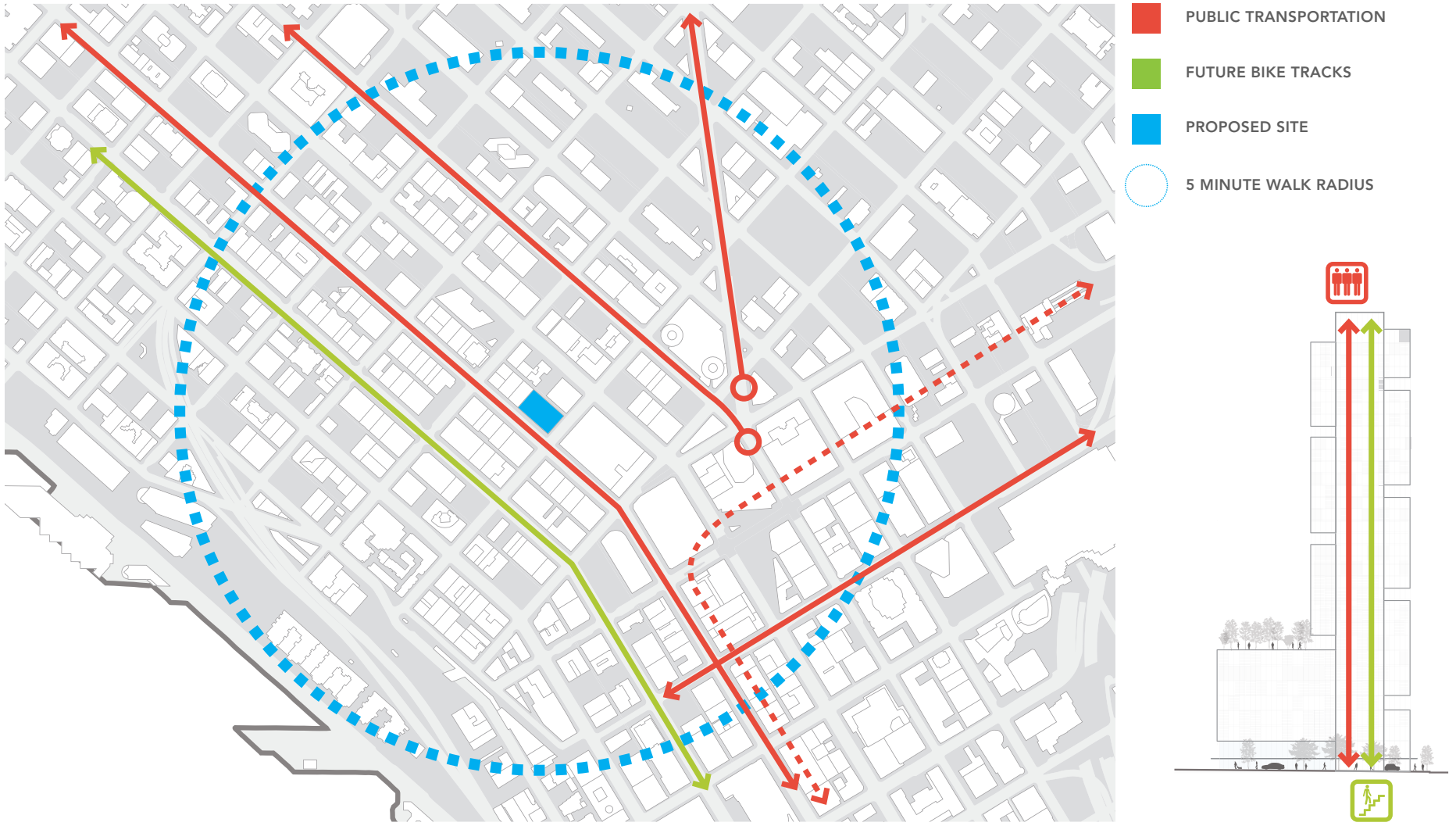

Figure 17: Site Context Maps + Diagrams

EXTENSION OF THE URBAN FABRIC



Figure 17: Site Context Maps + Diagrams

PROGRAM

The program for the project is directly adapted from the earlier identified needs of startups and entrepreneurs. As a result the three main program elements are affordable apartments + microunits, community/commons spaces, and coworking office space. In addition, programs such as a public market, retail/cafes, education/outreach, incubator spaces, and circulation were added to the project to integrate the project better into the urban fabric of the Belltown neighborhood.

COWORKING OFFICE

- RESERVED PRIVATE OFFICES
- RESERVED TEAM OFFICES
- RESERVED OPEN OFFICE DESKS
- HOT DESKS
- CONFERENCE ROOMS
- PHOTO LAB
- MULTI MEDIA CENTER
- SERVER ROOM
- SHIPPING/RECEIVING
- MAILBOXES
- PRINT ROOM
- WAREHOUSE + FULFILLMENT
- DIGITAL FABRICATION LAB

AFFORDABLE HOUSING

- 5 BEDROOM DORM APARTMENTS
- 2 BEDROOM CONDOS
- 1 BEDROOM APARTMENTS
- STUDIO MICRO APARTMENTS
- OUTDOOR BALCONY
- SPACE FOR A DESK
- SOUTHWESTERN EXPOSURE
- ADDITIONAL STORAGE
- STORAGE UNITS

COMMUNITY

- KITCHEN
- LOUNGE + COFFEE BAR
- WORK DISPLAY GALLERY
- IMPROMPTU PRESENTATION SPACE
- PING PONG TABLE
- ROOFTOP PATIO W/ BBQS
- GREEN ROOF
- COMMUNITY GARDEN
- GYM + FITNESS CENTER
- DAY CARE
- PET DAYCARE/DOG WALKERS
- BIKE STORAGE
- GROUND FLOOR MARKET/COMMONS
- CONTINUING EDUCATION CENTER

PUBLIC MARKET

- 10' X 10' POP UP SHOPS
- SHORT TERM LEASE RETAIL SPACE
- FOOD CART SPACES

RETAIL/CAFES

- SMALL CAFE/RESTAURANT SPACE
- OUTDOOR SEATING

EDUCATION/OUTREACH

- LECTURE HALL + FLEX SPACE
- STREET FRONTAGE + ENTRANCE
- AV EQUIPMENT AND SEATING

INCUBATOR

- MENTORSHIP AND LECTURE SPACES
- TEAM WORKSPACES
- SHARED LIVING SPACES

CIRCULATION

- ELEVATORS WITH CONTROLLED STOPS
- EXTERIOR STAIRS
- INTERIOR CONNECTING STAIRS

04

FINDINGS + DESIGN

CREATING A HUMAN SCALED TOWER TYPOLOGY

The current live/work typology in Seattle is corporate scaled and features high end market rate apartments at the top and large floor plates of class a office space for big businesses at the bottom. These programs are completely isolated and have separate circulation. As a result, the people who work there are not the people who live there. The proposed reinvented live/work typology, however, is human scaled. It uses outdoor spaces to break the tower into manageable interconnected communities. Each floor plate features micro units, a community commons area, and coworking office space which creates a vibrant mix of uses similar to a typical neighborhood.

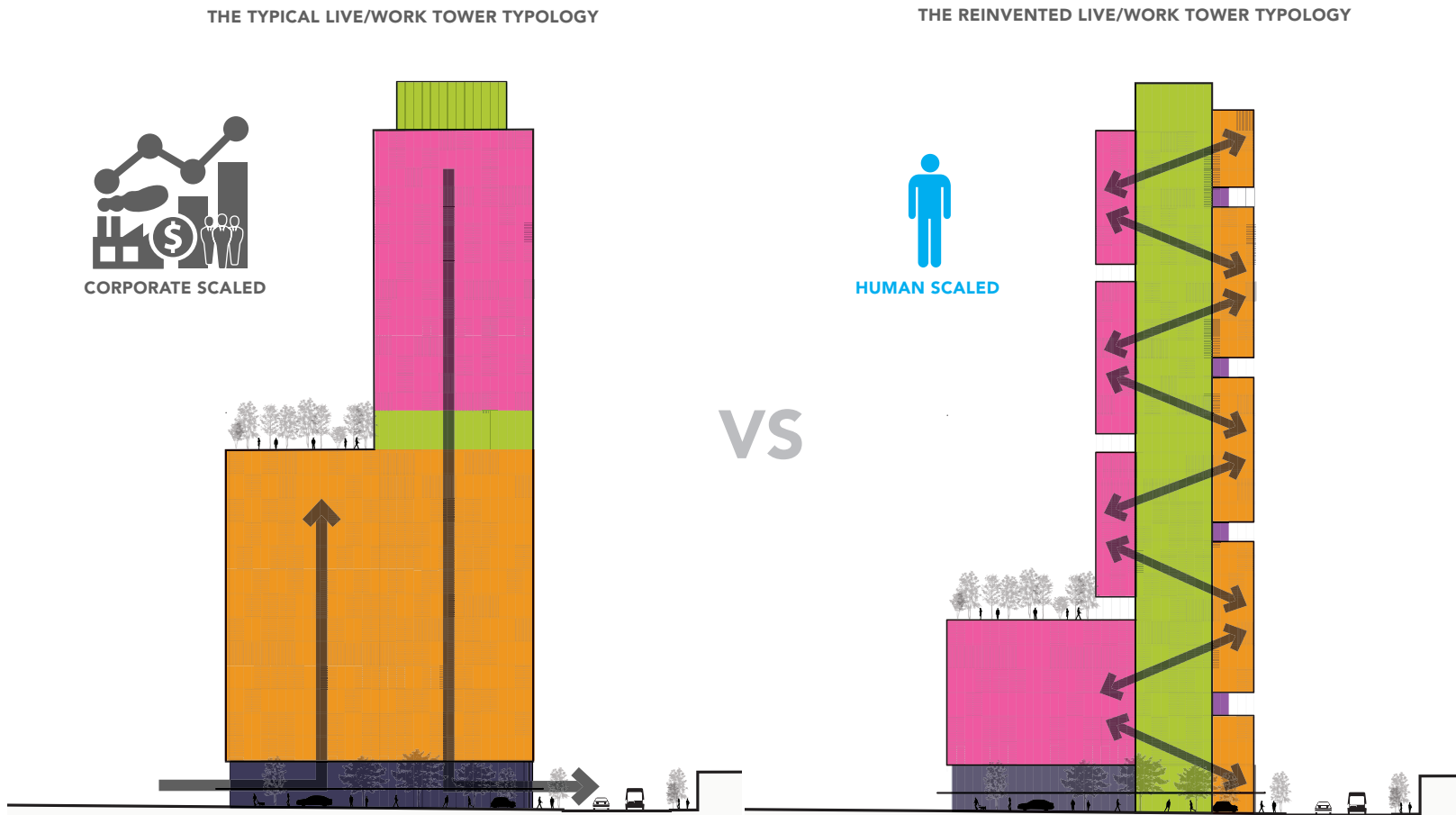

Figure 18: Corporate VS Human Scaled Diagram

VERTICAL NEIGHBORHOOD

The new proposed live/work high rise typology rejects the 20th century thinking of the highrise as a ruthless efficient machine for storing people and businesses and instead proposes thinking of the high rise as a neighborhood. Neighborhoods are human scaled environments that are typically the ideal setting for small businesses and communities. As a result, this new startup high rise typology takes cues from Seattle's vibrant neighborhoods such as Capitol Hill, Ballard, and Fremont.

After analyzing Belltown's existing urban fabric it became clear that the highrise needed to integrate into it and become an extension of the neighborhood. By providing for a diverse range of users, creating flexible spaces, mixed use floorplates, breaking down the scale of the tower, creating a network of vertical transportation and outdoor spaces this new typology embodies the essence of these vibrant neighborhoods.

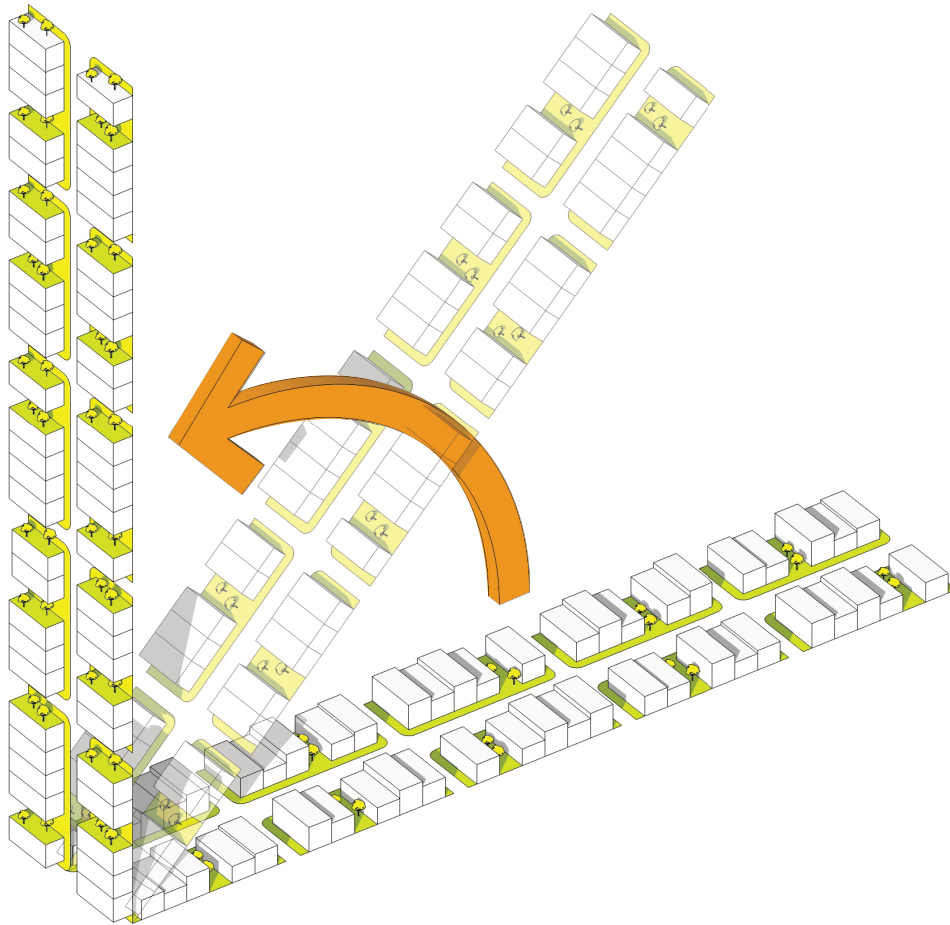

Figure 19: Vertical Neighborhood Diagram

DIVERSITY

Similar to one of Seattle's conventional neighborhoods the proposed live/work high rise typology must cater to a wide demographic. This vertical neighborhood must address the needs of startup founders and entrepreneurs from all family stages ranging from single individuals to families. In addition, it must provide flexible work spaces and an array of services to accommodate small businesses and startups ranging from software development to light industrial. This diversity of businesses and entrepreneurs helps establish a rich community where ideas, knowledge, and skills can be exchanged.

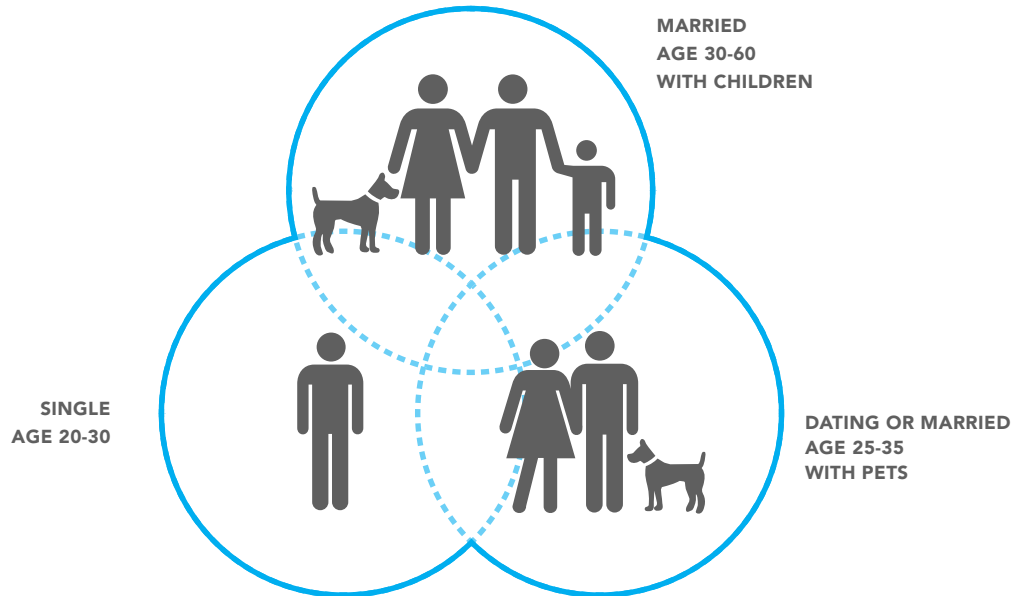
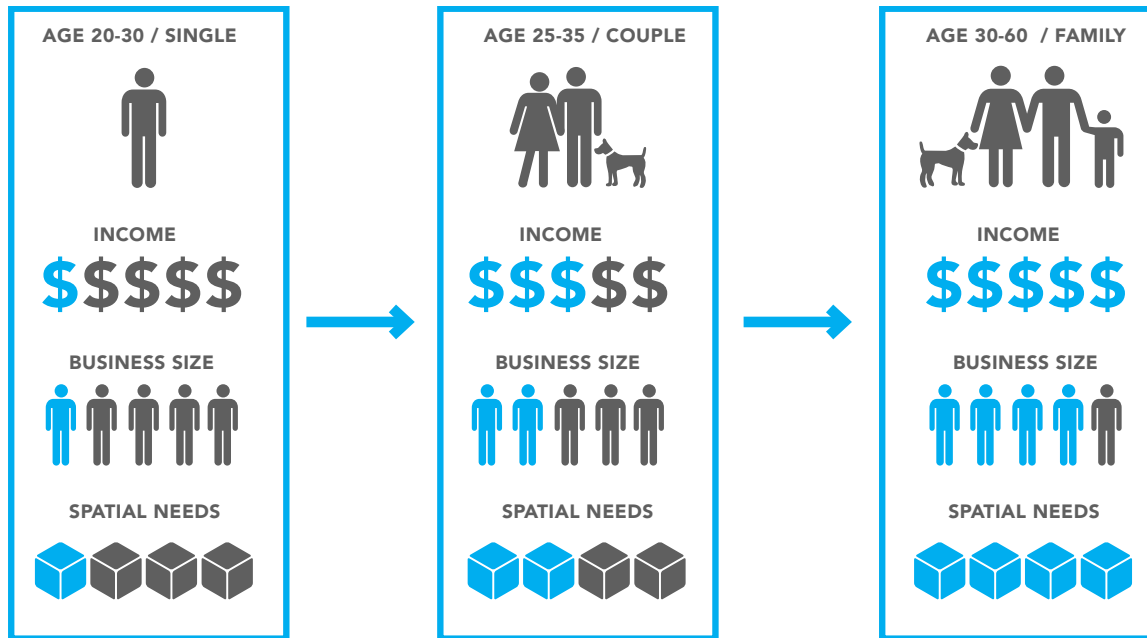

Figure 20: Diversity Diagram



FLEXIBILITY

As you can imagine the spatial needs of entrepreneurs and startup founder changes over the course of their lives. For example, a recent college graduate who is single probably has a relatively small business and as a result needs less space. But as that individual ages and their business grows their spatial need increase as well.

To address and accommodate for the expansion and contraction of families and businesses this new high rise typology provides a variety of unit types ranging from 5 bedroom dorm clusters to 2 bedroom units for families. The coworking dedicated offices are leased on a month to month basis and consist of a flexible 8 foot by 8 foot space. This module allows companies to lease continuous spaces next to each other for equipment or spread the desks out more organically to have employees interacting on a daily basis with coworkers from different businesses. This allows individuals working for a company to decide what environment is best for them to work in rather than the employer prescribing it. This variety of unit sizes and office space flexibility is critical to meeting the needs of startups.

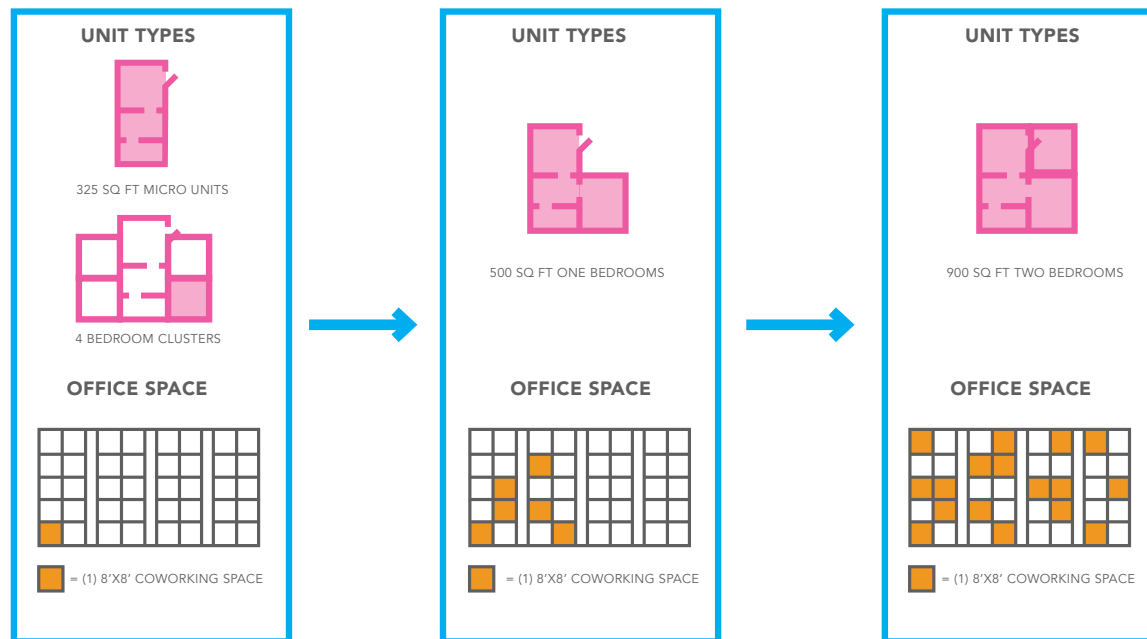

Figure 21: Flexibility Diagram

POTENTIAL MEMBERSHIP PACKAGES

For this new high rise typology to integrate into the urban fabric it is important that a flow of people move between the tower and the greater neighborhood. About 60% of the towers users just work in the startup high rise while the other 40% both live and work there. To achieve this, the startup high rise offers membership packages starting at shared commons access catered towards mobile workers who typically work out of cafes. These mobile workers occupy the tower's shared common areas making these spaces revenue generating. In addition to shared commons passes there are dedicated workspace, live/work, and incubator packages.

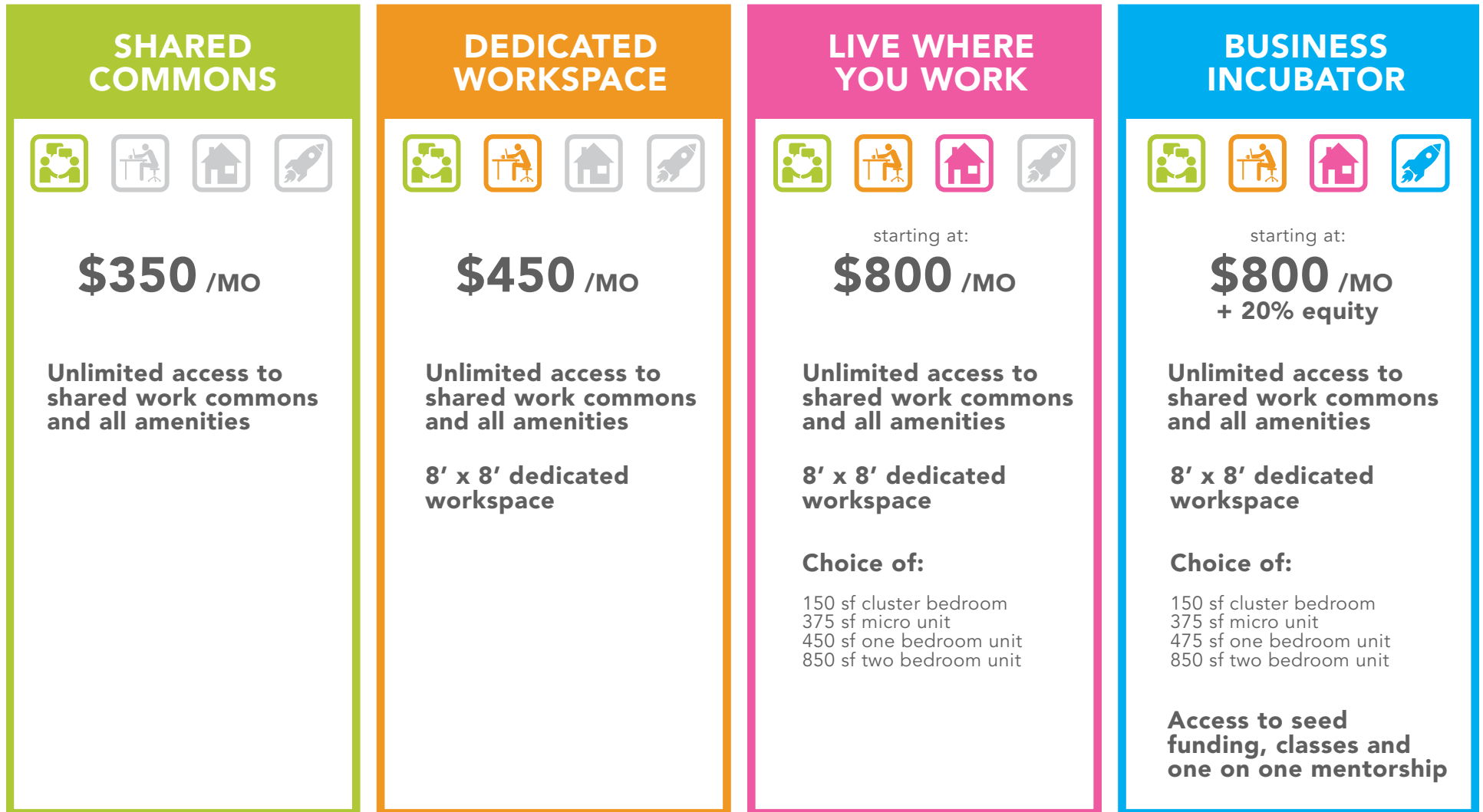

Figure 22: Potential Membership Packages

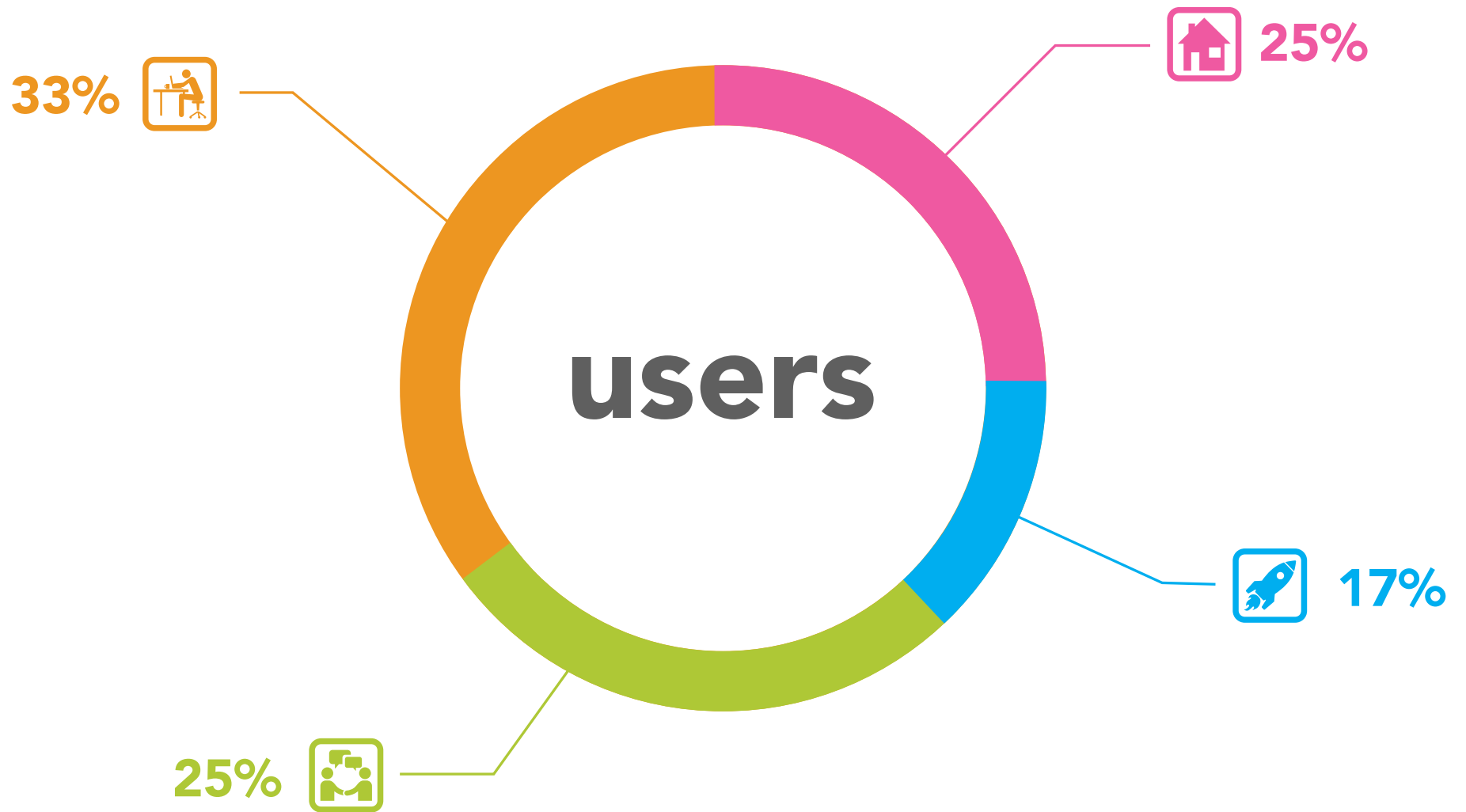
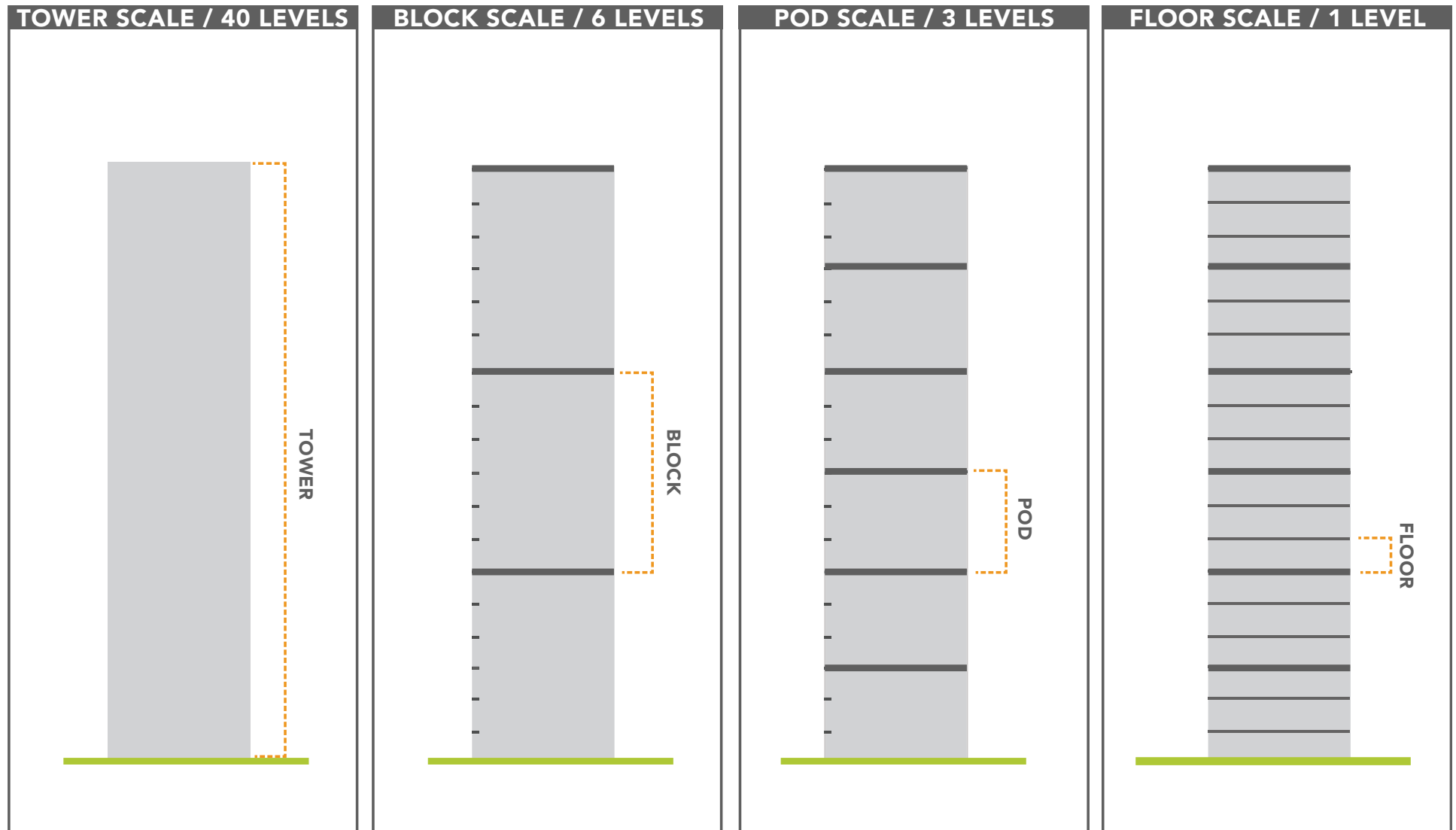

Figure 23: Membership Package Percentages

BREAKING DOWN THE TOWER SCALE

One of the most important steps in achieving a vertical neighborhood is breaking down the scale of the monotonous 40 story high rise. Much like a traditional neighborhood, breaking the tower into “blocks” helps create distinction and gives identity to that spaces within each block. Dividing each block then into two “pods”, similar to the building scale, creates a more intimate scale for interaction between users. Within each pod are 3 levels which add another layer to hierarchy of order within the proposed startup high rise typology.



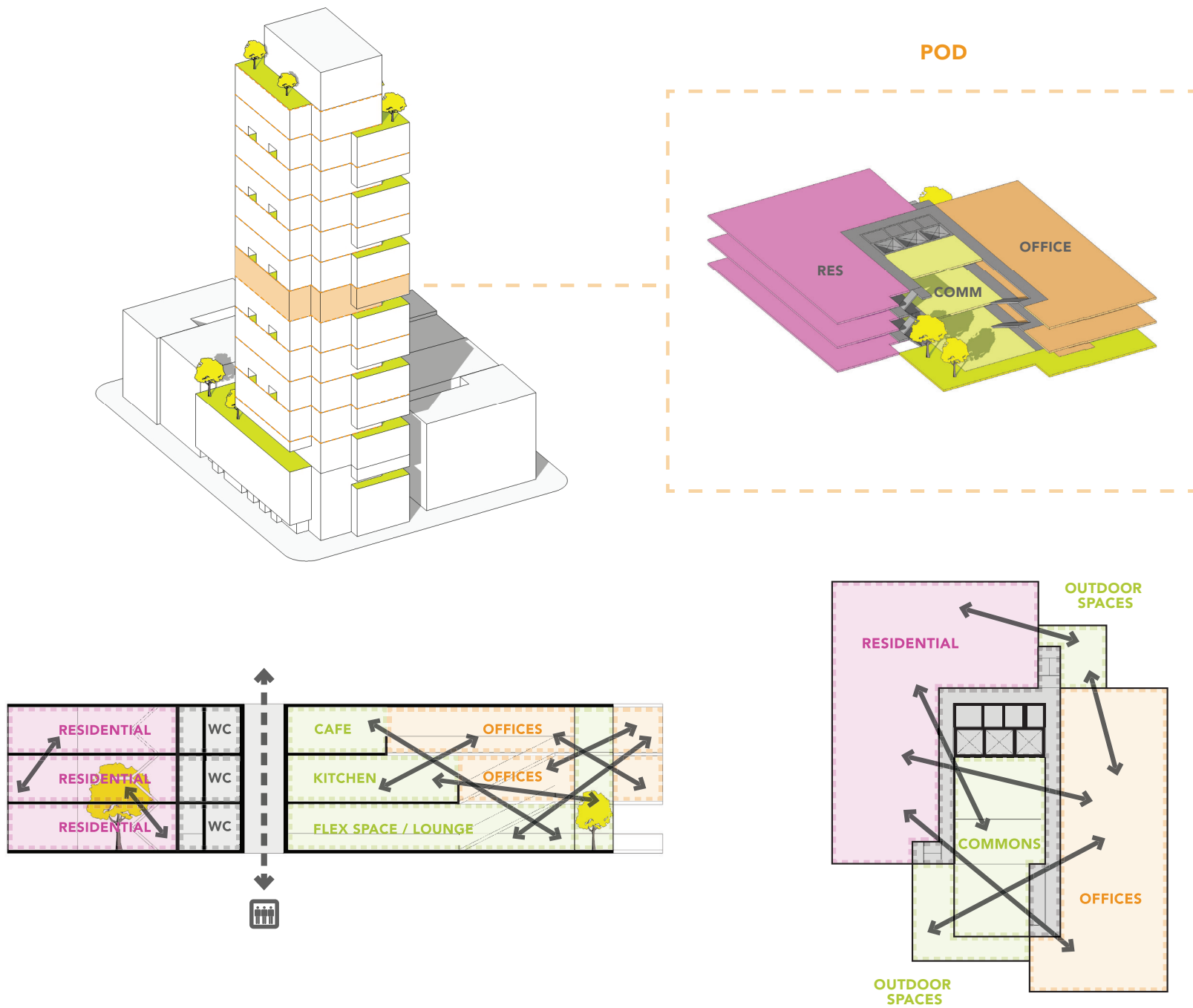

Figure 25: Block and Pod Diagrams

TRANSPORTATION

Once again the startup high rise typology takes cues from the urban fabric in regards to transportation. It rejects the 20th century high rise thinking of elevators as automobiles that bring you directly to your floor. Instead it proposes elevators as public transportation where they deliver you to your pod but not your individual floor. By doing so the elevators can run more efficiently and distribute larger quantities of people. This also by nature creates opportunities for interaction at each pod's landing level. Furthermore, the proposal aims to celebrate stairs instead of viewing them as a code requirement that is only used in a worst case scenario. The stairs are brought to the exterior of the buildings and serve as important connectors between the numerous outdoor spaces that define each block. As a result, these stairs and hallways are viewed as public sidewalks in a traditional neighborhood which connect blocks and parks together. By thinking of elevators as public transportation and stairs and hallways as public sidewalks, the startup high rise's circulation reinforces the idea of a vertical neighborhood and the established hierarchy of scales.

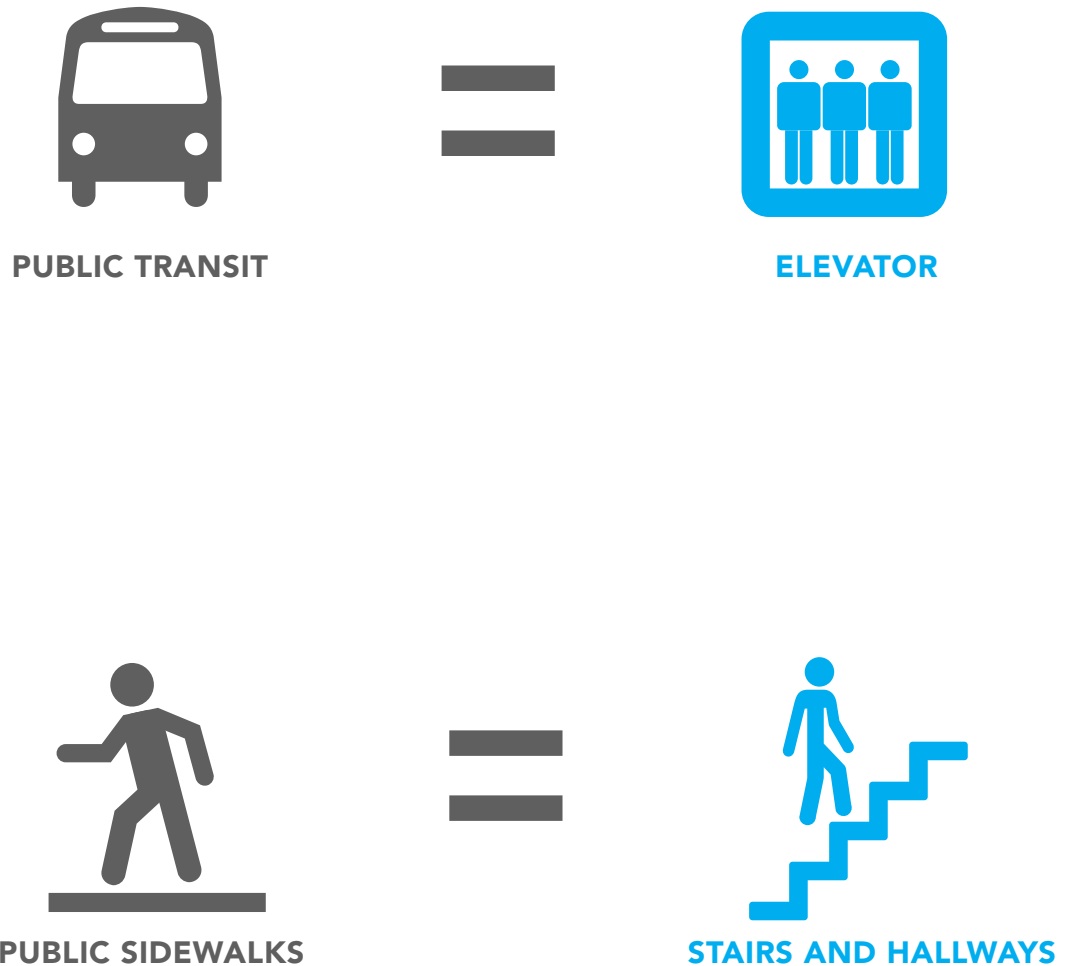

Figure 26: Transportation Diagram

INTERACTION

This new way of thinking about how stairs and elevators function in a highrise allows the proposed highrise to change the way users interact as they move through spaces. It essentially allows each pod to operate as 3 story building rather than one of many floors within a highrise. By making it more convenient for users to take an interconnecting stair within each pod instead of an elevator to their specific floor, opportunities for interaction can be created. Large landings and seating integrated into this interconnecting stair provides space for people to have a conversation in passing. Furthermore, through walking past other dedicated coworking spaces and common areas, users can see what their peers are working on and what social events are occurring. It doesn't force people to interact but provides a mechanism should they choose to. This is similar to how in a small neighborhood a bus drops people off at the street corner and by walking up the street people come in contact with their neighborhood small businesses as well as other members in their community. This interaction is essential in creating a vibrant community within the startup highrise.

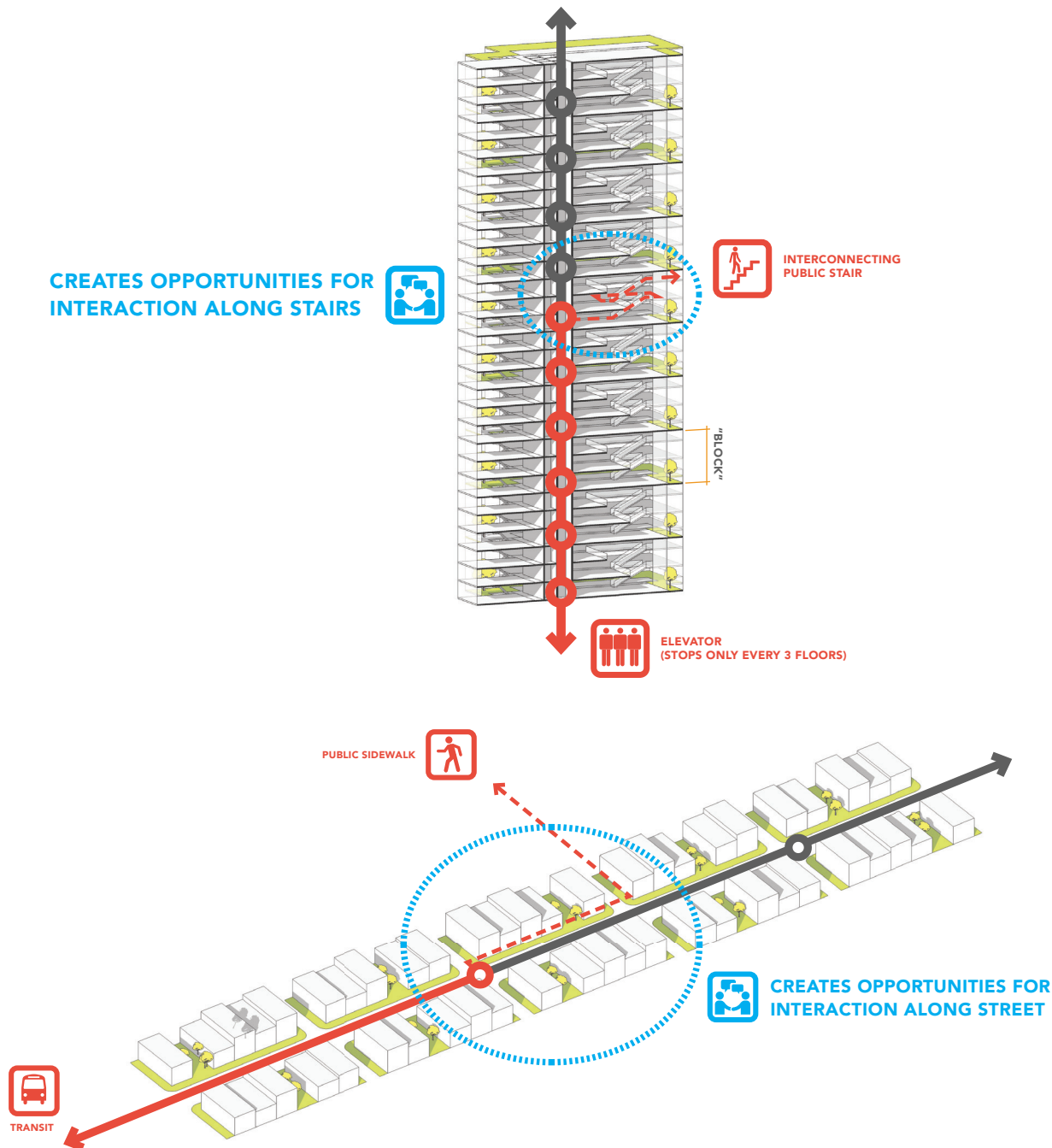

Figure 27: Interaction from Circulation Diagram

FORM EVOLUTION

The form of this new live/work high rise typology emerges from a combination of zoning, context, and programmatic factors. The site chosen is 19,300 square feet and is a quarter block site. The zoning envelope allows for a 450 foot tall tower. The program is then oriented with residential to the west and office space on the east. The podium is articulated to create a ground level public market. By shifting the residential and office programs views from the community commons open up to Mt. Rainier and the Puget Sound.

Stepping the top of the tower creates a more slender tower. Blocks and Pods are then created by dividing the tower into levels of 6 and 3. By splitting the high rise at these blocks, the massing expresses them on the exterior. Sloping the masses and creating indentations creates variation between blocks. The massing becomes a network of outdoor spaces that responds to sun with morning light for the offices and afternoon sun for the housing. An interior street is carved into L1 to create an interface with the community.

01 SITE

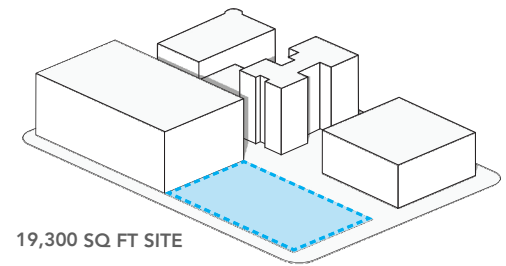

02 ZONING MASS

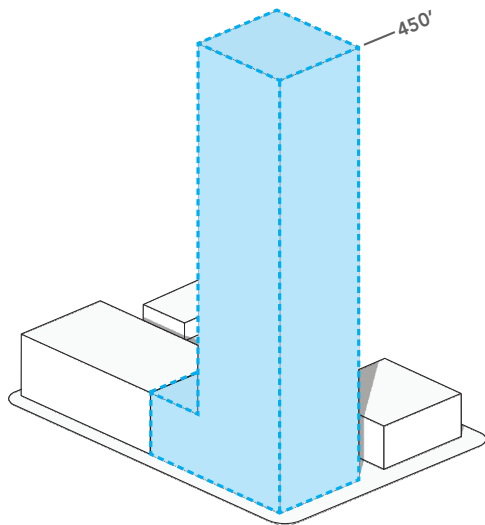

03 PROGRAM

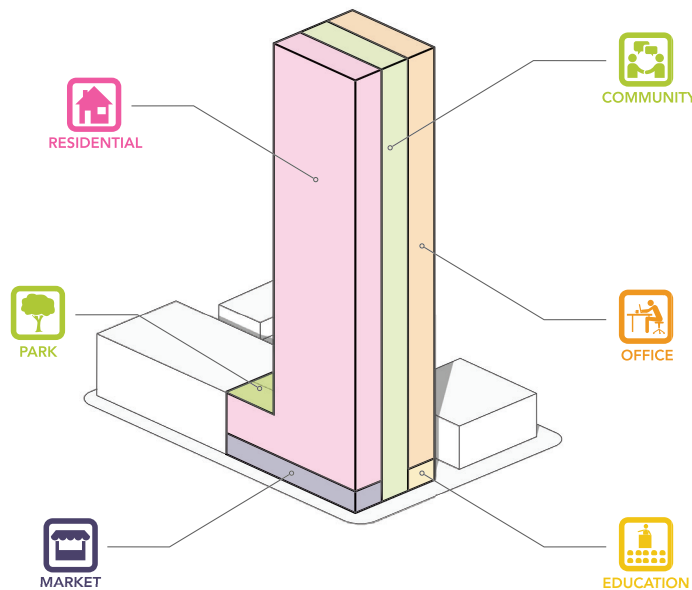

04 PODIUM ARTICULATION

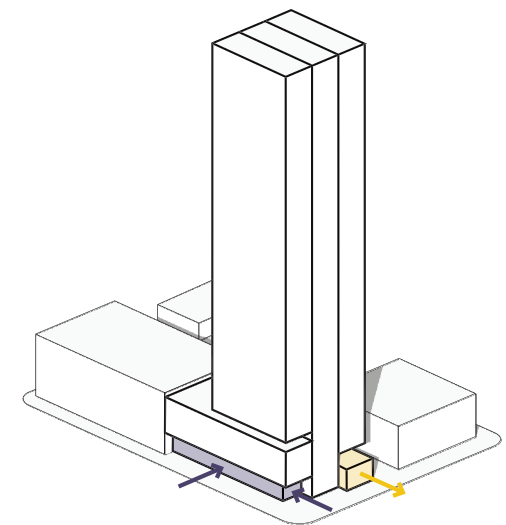
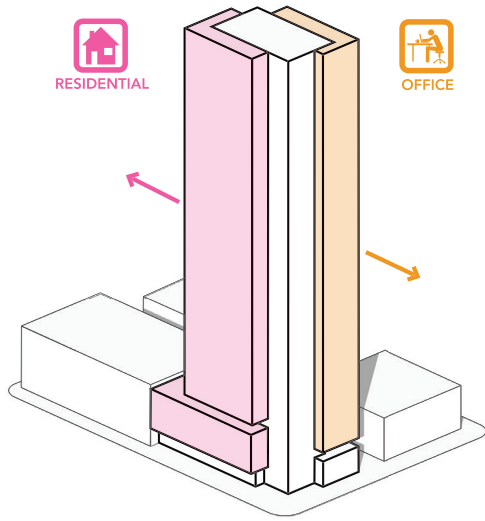
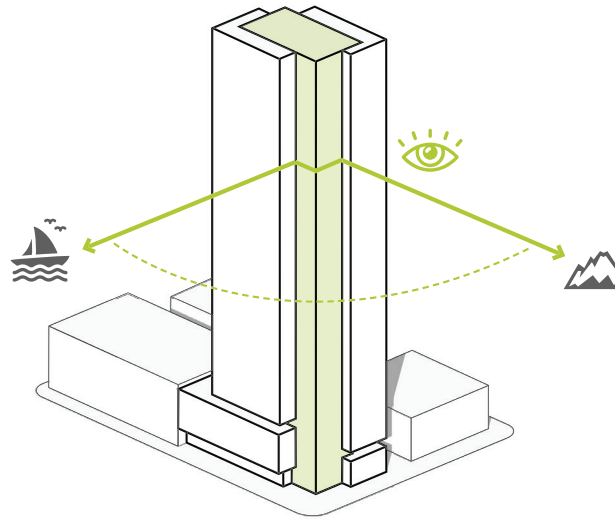

Figure 28: Form Evolution Diagrams

05 SHIFT



06 VIEWS



07 STEP

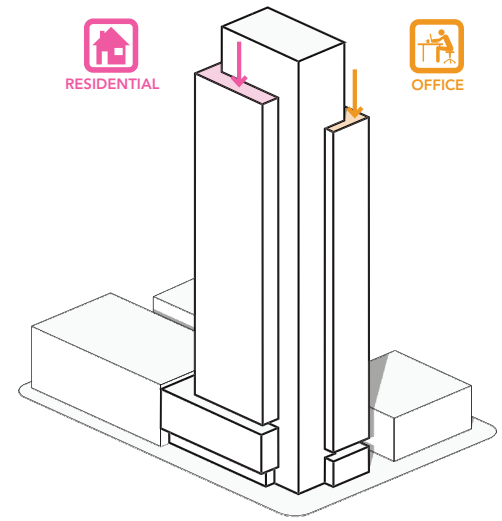

08 DIVIDE

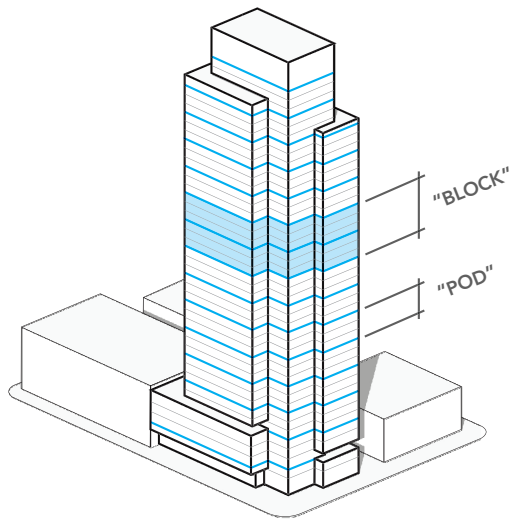

09 SPLIT

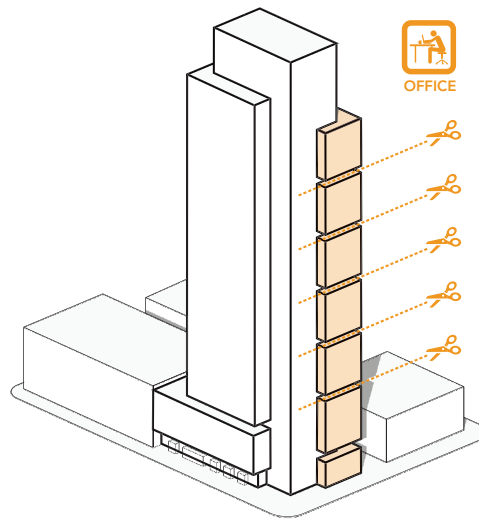

10 SLOPE

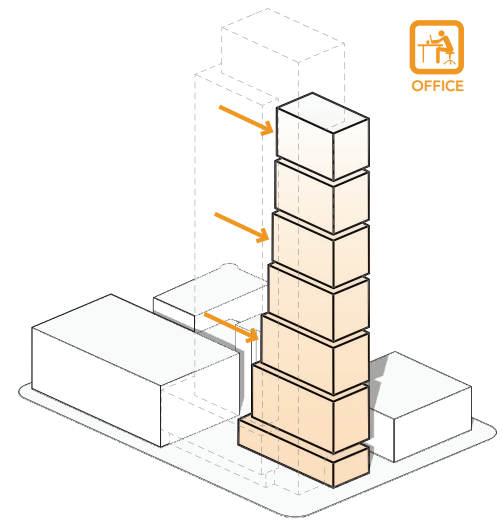
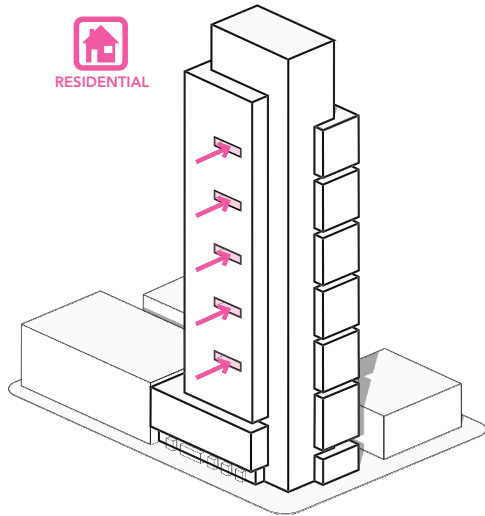
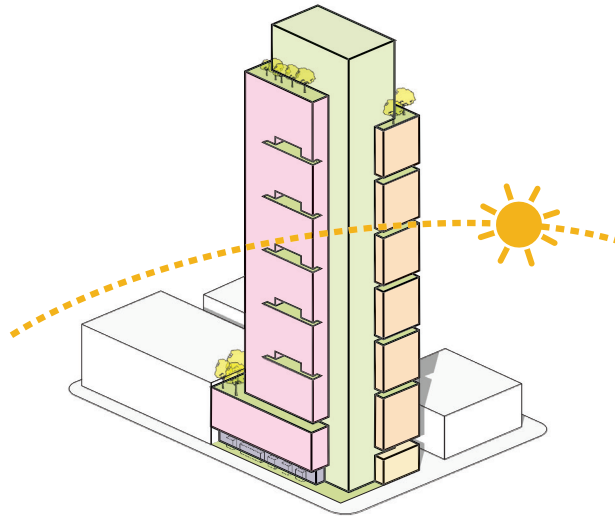

Figure 28: Form Evolution Diagrams

11 INDENT



12 SOLAR ORIENTATION



13 OUTDOOR SPACES

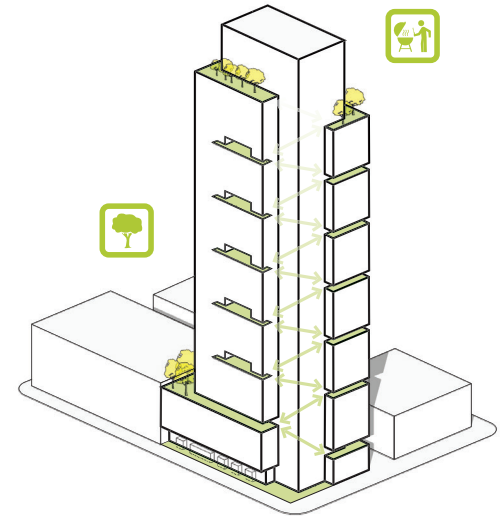

14 GROUND LEVEL

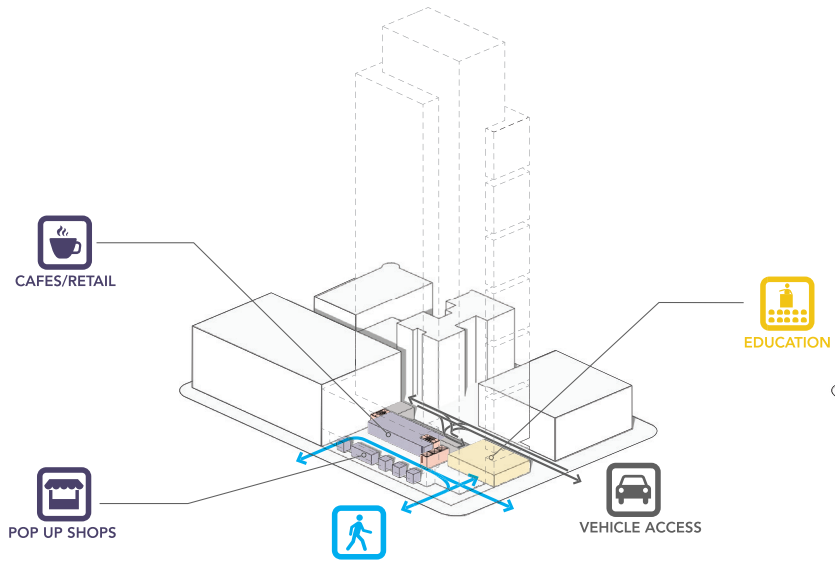

15 FINAL ARTICULATION



Figure 28: Form Evolution Diagrams

NORTH SECTION

In section the residential program is laid out to the left with community common areas in the middle and office space to the right. The outdoor workspaces and residential green spaces creates a staggered network of outdoor spaces that clearly divides the tower into blocks and pods. At the podium of the tower exists a larger common green space that features a playground for a daycare and outdoor gym. The tower includes 4 levels of parking mainly intended for clients visiting as well as users who work in the tower but do not live there.

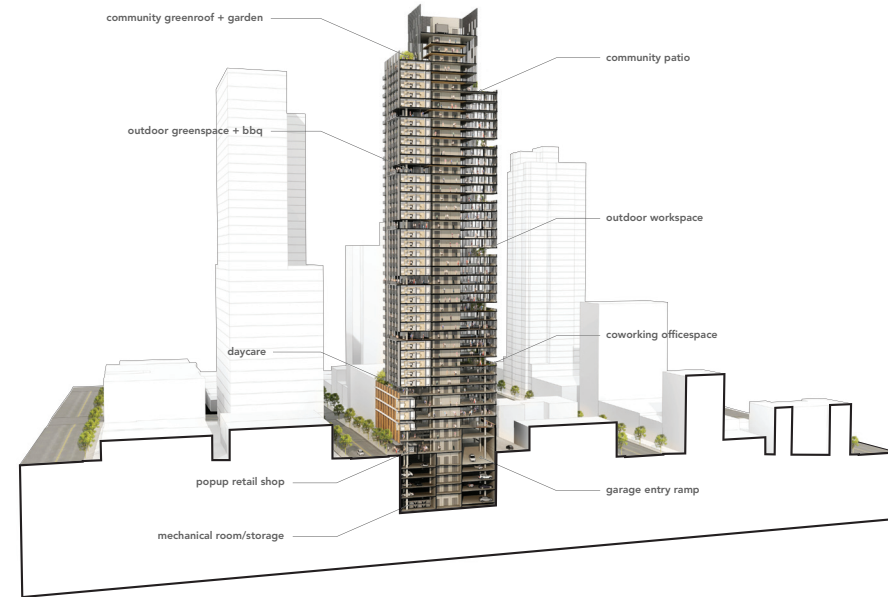

To achieve both residential and office uses on the same floor the high rise employs 21st century building systems such as radiant floor heating. By decoupling the heating and cooling systems from the ventilation the tower is able to accommodate office space with a post tension concrete structure and a 10 ft floor to floor height. Ground source heat wells and heat pumps in the basement provide the radiant heating and cooling for each level while a heat recovery ventilator and operable windows ventilate the highrise.

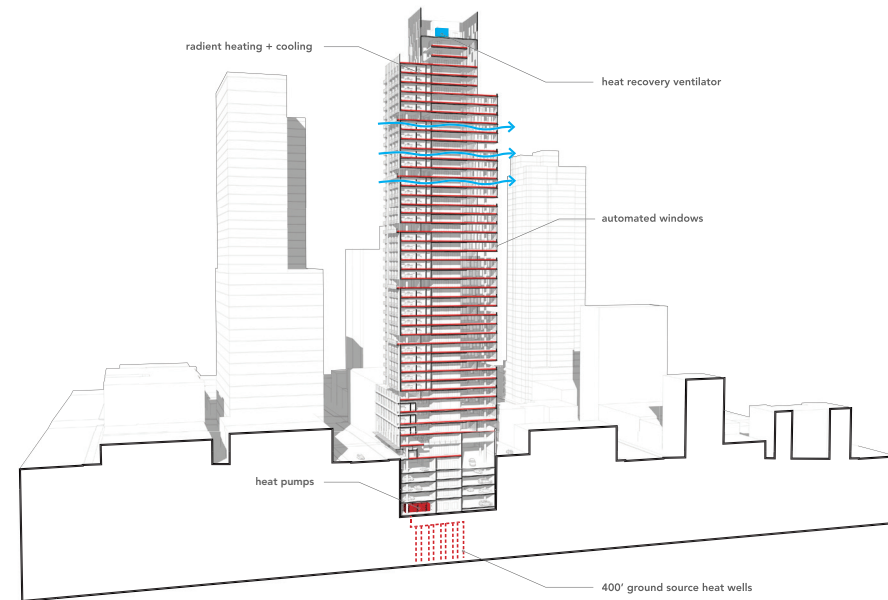

Figure 29: North Section Illustrations

EAST SECTION

The East section through the high rise showcases the community commons that are the heart of each pod. These community commons feature an interconnecting stair between levels as well as a flexible space on the first level, a kitchen on the second, and a cafe on the third. On the ground level a pedestrian street is created to allow for an interior double height public market place. A lightwell provides daylight and fresh air to the public market to create an atmosphere similar to Seattle's Pike Place Market. The first level of the marketplace contains mainly small local shops while the mezzanine above houses restaurants, cafes, and bars.

The building tries to implement passive ventilation to provide fresh air to the occupants. The semi-conditioned, outdoor spaces allows air to gradually rise over the height of the building for stack ventilation. Automated operable windows in each pod open up to the outdoor spaces to exhaust hot air and intake fresh cool air. Similarly the public market on the ground level employs stack ventilation with an operable skylight to allow hot air to exhaust.

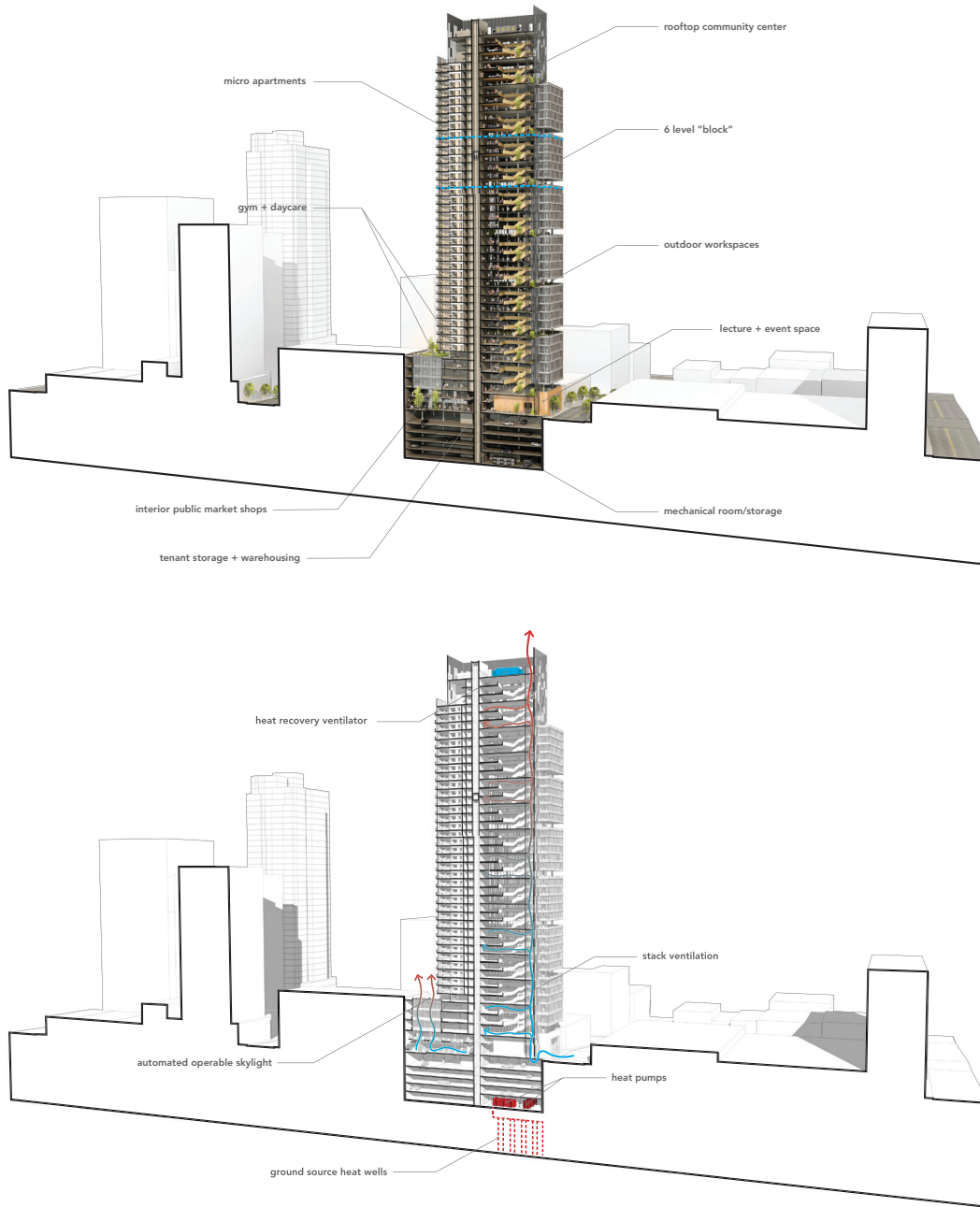

Figure 30: East Section Illustrations



VIEW LOOKING NORTH ON 3RD AVE



COMMUNITY COMMONS FACADE

The facade for the community commons program of the building uses a curtain wall system that has butt-glazed vertical and horizontal mullions. The curtain wall is a double envelope that has a single pane outer layer and double pane inner layer. The semi-conditioned space between the layers has metal grates that allows for stack ventilation up the length of the facade to occur. The dynamic shading devices attached to the mullions of the outer layer reinforce the active nature of these spaces. Overall, the community commons facade is intended to appear transparent to reveal the vegetation and activities within.

COWORKING OFFICE SPACE FACADE

The coworking office facade faces east but because the city grid is off axis it does not face it directly. As a result, vertical fins in addition to an automated interior venetian blind system are used to mitigate low morning sunlight. Automated operable windows every 8 ft along the facade provide fresh air on temperate days for ventilation. Like most typical office buildings the fenestration is in horizontal bands to provide even daylighting. To emphasize this horizontality the facade has bands of insulated metal panel and spandrel glass as well as staggered vertical fins. This all helps to express the office program to the exterior.

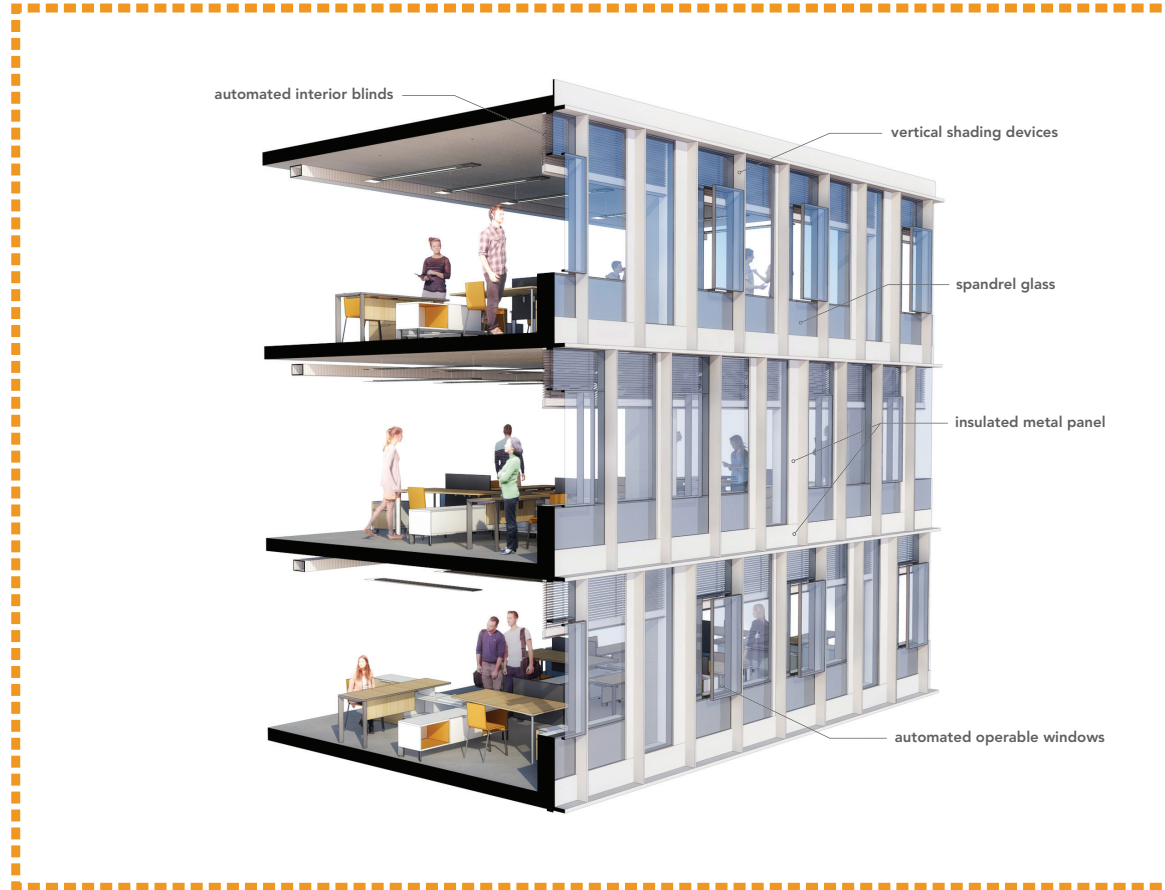

Figure 32: Coworking Office Space Facade Illustrations 67



VIEW LOOKING SOUTH ON 3RD AVE



RESIDENTIAL FACADE

To contrast the horizontality of the office facade system the residential facade is vertical in nature. The verticality of the system allows for floor to ceiling glass in the living rooms of the apartment units, as well as continuous vertical fins to help mitigate heat gain from the afternoon direct sunlight. Vertical bands of insulated metal panels and spandrel glass cover the demising walls and solid portions of the facade. Small balconies are thermally isolated and attached to the slab and wall system so that residents can open their sliding doors and have enough room to step out. This modular window wall system provides stark contrast from the transparency of the community and horizontality of the office program elements.

PODIUM FACADE

The podium of the highrise is intended to appear more heavy and solid compared to the rest of the tower. To articulate the podium, the facade uses a terracotta rainscreen system and spandrel glass for the opaque portions of the assembly. In contrast to the residential facade above the podium has larger portions of solid and more narrow bands of glazing. The ground level however, is a butt-glazed curtain wall system with pop up shops embedded in it. This gives the appearance that the solid podium mass is floating above.



Figure 34: Podium Facade Illustrations

BUILDING EXTERIOR EXPRESSION

The final building expression is a composition of the three program elements and their directional facade systems. The community commons is uniform in direction and separates the residential facade which is vertical from the office facade which is horizontal. The podium is then articulated from the tower with the use of a more solid terracotta facade. The high rise is able to be clearly read and understood architecturally through the obvious expression of each of the program elements. This simple visual understanding is important in displaying to others how this new live/work high rise typology works radically different from its predecessors.



VIEW LOOKING EAST ON LENORA ST



Figure 36: View from Columbia Tower Illustration

DIVIDING INTO "BLOCKS" AND "PODS"

One of the most important design concepts in the startup high rise is the idea of breaking down the high rise scale by dividing it into blocks of 6 levels which then consists of 2 pods (3 levels each). This is essential in trying to create distinct vibrant communities within the tower. Each pod is 3 levels based on the current fire code which allows open space up to 3

stories before atrium conditions apply. In addition, anything above 30 ft tall begins to start to make people scared of heights. As a result, it was important for cost and scale that the pods do not exceed 3 open levels. To give each pod unique character within a block they have slightly different floorplans. Pod A has outdoor workspace on the East side while the other pod,

Pod B has an outdoor residential space on the west side of the tower. This subtle variation allows for each pod to assume its own identity and adapt the community commons to best suit the activities that occur on the outdoor spaces. As a result, the tower establishes a framework that encourages users to shape the spaces, and creates distinction between levels.

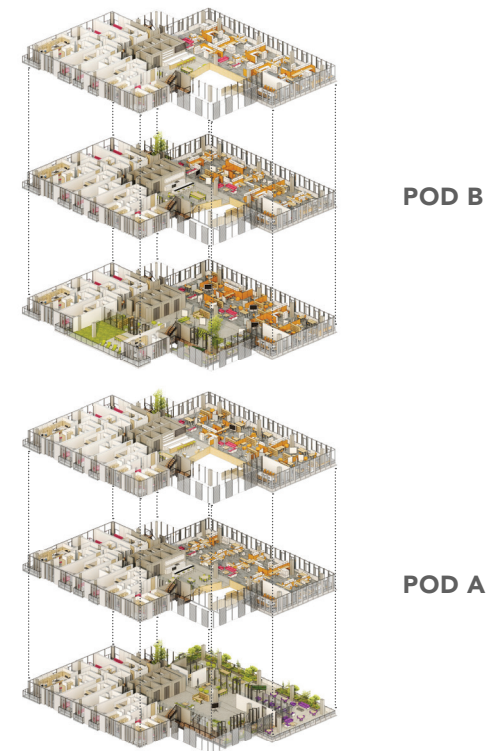
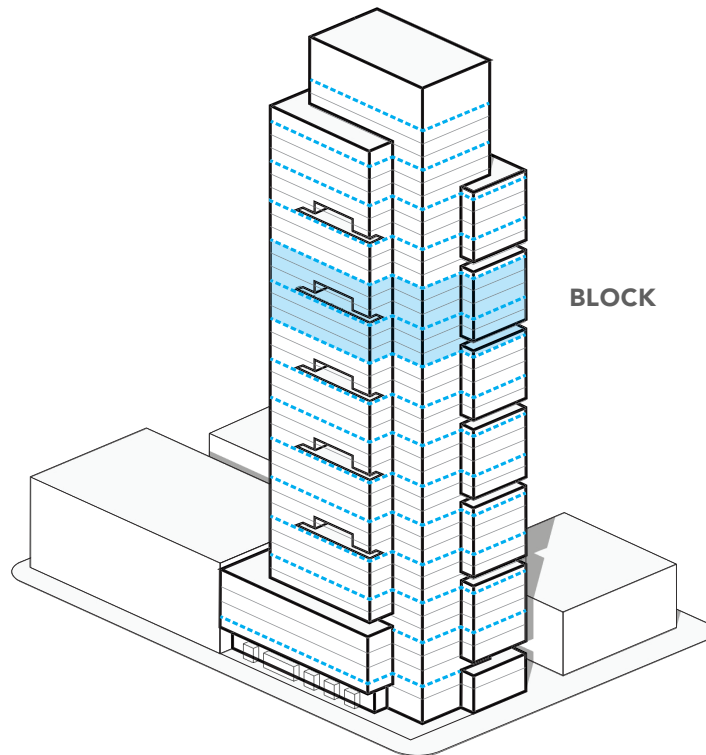

Figure 37: Block and Pod Axon Diagrams

LEVEL 01



LEVEL 02



LEVEL 03



Figure 38: Pod A Floorplans

POD A FLOORPLANS

The floorplans for all 3 levels consist of community commons space in the middle and residential units on the West. The first level has an outdoor workspace while levels 2 and 3 have coworking dedicated workspace. Each level has a garbage room with both recycling and garbage shoots, 3 ADA accessible bathrooms, electrical room and 11 apartment units. The units comprise of 5 bedrooms in a dorm style

cluster, 2 micro unit studios, 3 micro unit one bedrooms, and 1 two bedroom unit. Imbedded in the residential side of the floorplate are 3 individual quiet rooms for entrepreneurs who may need a more private place to work or make phone calls. Likewise, couches and lounge chairs are embedded in the coworking side to provide spaces for people to have conversations and collaborate.

Conference rooms are located at the end of each interconnecting stair so that they can easily be accessed for meeting with clients. Within the community commons the first level provides flexible space for activities and events while the second level has a kitchen for cooking and the third has a coffee bar for socializing.

POD B FLOORPLANS

Pod B is similar to Pod A in terms of levels 2 and 3. However, level 1 has a residential outdoor space carved out of the apartment units as well as coworking office space on the East side. As a result, Pod A becomes a more work centric pod and Pod B becomes more of a residential centric pod. For example, Pod A has covered outdoor space with tables for a privately owned restaurant or cafe and

informal presentation spaces for work. In contrast, the outdoor residential space serves as an area for residents to relax and unwind while having the benefits of a backyard. The outdoor space provides a bbq for grilling dinner and a large outdoor dining table. Lounge chairs allow sunlight starved Seattleites to soak up the late afternoon sun while a patch of artificial grass serves as an urban backyard for

activities and lawn games. While the pods share many similarities the distinction between having outdoor work space and outdoor residential space makes each pod unique and integral to one another.



Figure 39: Pod B Floorplans

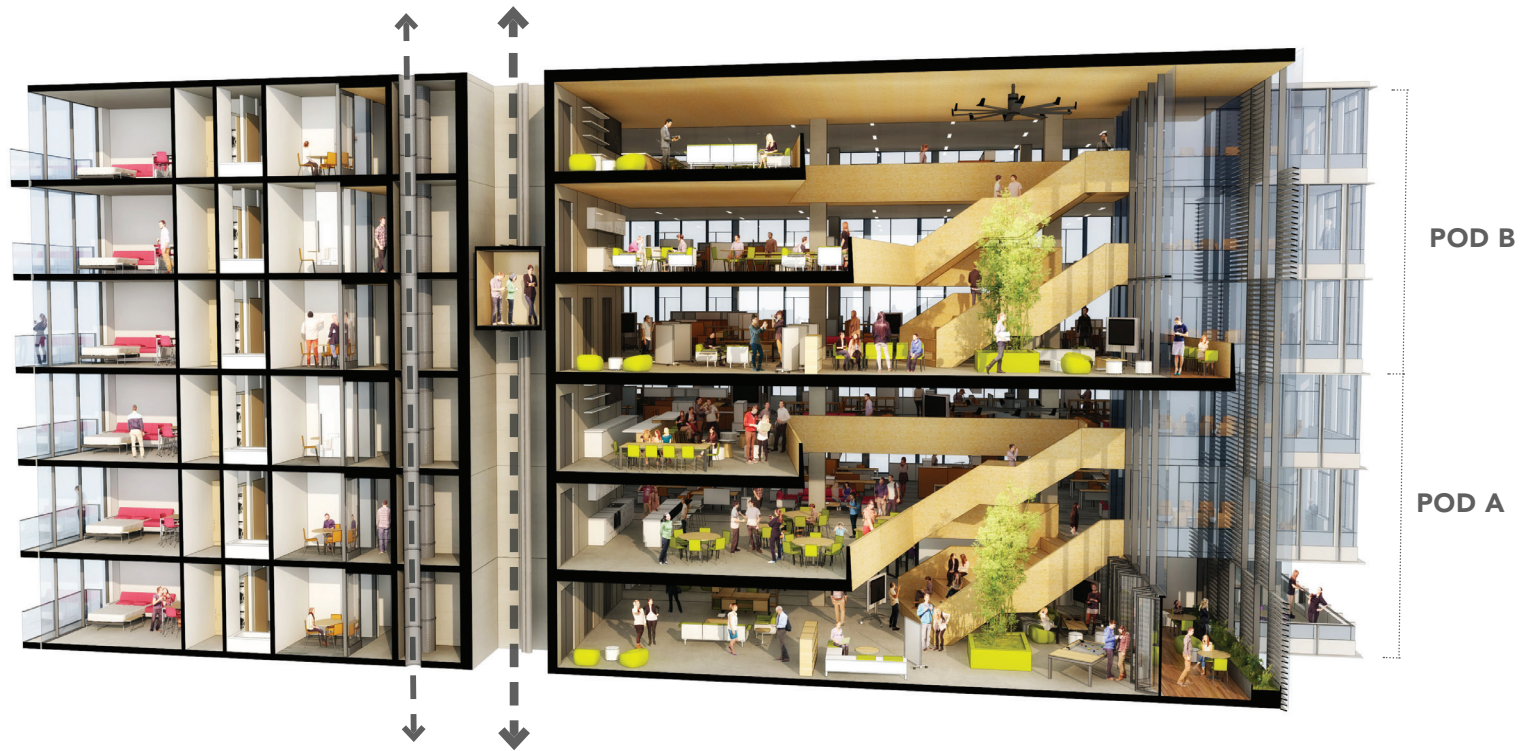

Figure 40: Block Section Illustration

BLOCK SECTION

Each block throughout the startup high rise is joined by the semi conditioned outdoor rooms just off of the community commons flex space. Within this double envelope space visual connections are made between pods and an exterior stair connects them together. Likewise, air is able to move between blocks and pods to provide stack ventilation. Within

each pod the upper levels pull back to allow for terracing to capture sunlight and allow entrepreneurs to look down to spaces below. This allows for visual connection and conversations to occur between common spaces within a pod. This inner commons is also clad with a poly-coated oriented strand board (OSB) to give the space warmth but capture the

resourcefulness of the entrepreneurial spirit. A Big Ass Fan at the ceiling of each pod helps circulate airflow for thermal comfort. Each pod is designed to connect to the larger network of the tower while providing flexibility and encouraging interaction between entrepreneurs.

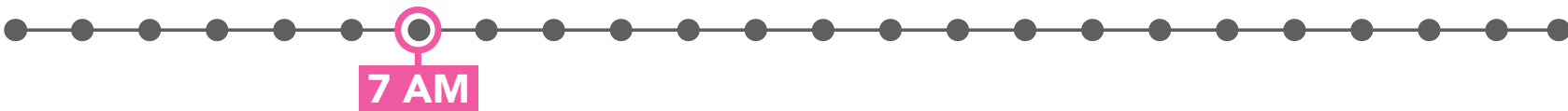

Figure 41: Startup Life Micro Unit

STARTUP LIFE MICRO UNIT

Life within the startup high rise is vastly different than the typical live/work high rise. Entrepreneurs who choose to both live and work within the tower start their day off in their private units. While compact, each unit provides the necessities for comfortable living and maintaining a high quality of life while also having additional amenities just outside their front door.

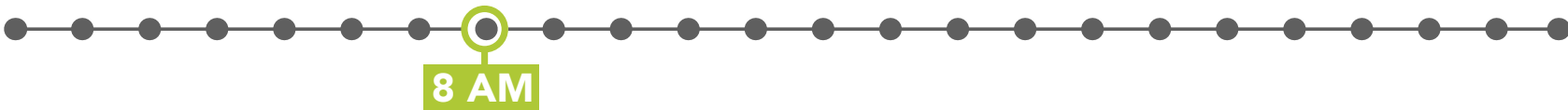

Figure 42: Startup Life Commons Kitchen

STARTUP LIFE COMMONS KITCHEN

A community kitchen located on the second level of each pod provides professional cooking and coffee equipment as well as larger dining area. This space enables interaction between people who live within the tower making breakfast and coworkers who may have stayed up late the night before working. It serves as a large gathering area for both residents and workers to start their morning.

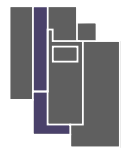
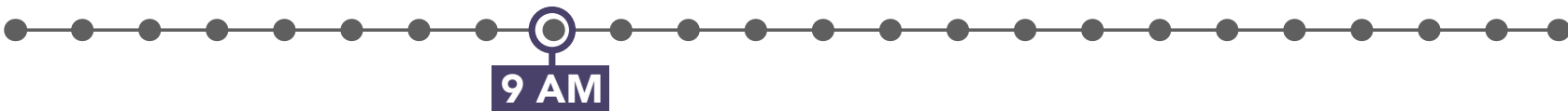

Figure 43: Startup Life Public Marketplace

STARTUP LIFE PUBLIC MARKETPLACE

A public market in the ground level of the highrise acts as an interface between the startup community housed in the tower and the Belltown neighborhood. It serves as the landing point for many of the workers who live nearby and work within the tower. It provides the perfect space for people who live in the highrise to interact with people who are coming into work in the highrise.

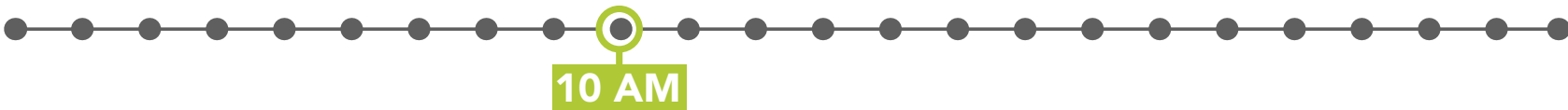

Figure 44: Startup Life Commons Flex Space

STARTUP LIFE COMMONS FLEX SPACE

At the first level of each pod, where all 3 of the elevators land, is a community commons flex space. This space has a large stair to guide workers and clients up to the other levels. This stair has seating integrated into it to create an impromptu presentation space which is ideal for hosting events such as hackathons or idea pitches. Flexible furniture also allows the inhabitants to adapt the space as needed.



Figure 45: Startup Life Sky Park

STARTUP LIFE SKY PARK

In live/work typologies its important that to maintain a healthy balance between life and work. Semi-conditioned outdoor space called “sky parks” provide room for activities and games to get workers up out of their desks to improve productivity. Ping pong among other activities can also encourage healthy competition and interactions between workers who otherwise may not have much in common.



Figure 46: Startup Life Outdoor Lounge

STARTUP LIFE OUTDOOR LOUNGE

Each block has potential leaseable space for local restaurants, cafes, bakeries, and bars that spills out onto the outdoor workspace. These businesses can provide meals and beverages to the entrepreneurs who occupy the block as well as the general public during business hours. The local restaurants, cafes, bakeries, and bars can help add to the distinction between blocks within the tower.



2 PM



Figure 47: Startup Life Dedicated Workspaces

STARTUP LIFE DEDICATED WORKSPACES

Coworking spaces by nature provide opportunities for entrepreneurs from a wide array of occupations to work together and collaborate. For example, if someone who runs an accounting practice rebrands their business and needs a new logo they can easily ask someone next to them if they know anyone that they've worked with before. These face to face referrals encourage collaboration between startups.

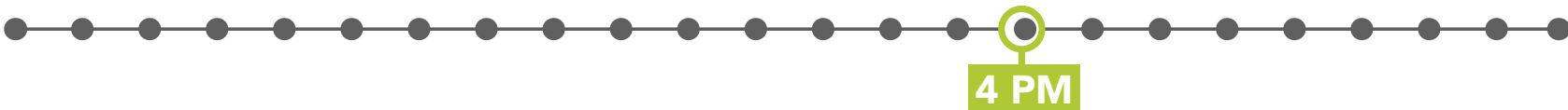

Figure 48: Startup Life Commons Flex Space

STARTUP LIFE COMMONS FLEX SPACE

Live/work housing allows entrepreneurs to be closer to the people who really matter in life, their friends and family. By always being within arms reach, even while at work, entrepreneurs can use the community commons flex spaces for both personal and work use. This allows entrepreneurs to be with their kids when they get home from school instead of having them go to a daycare.

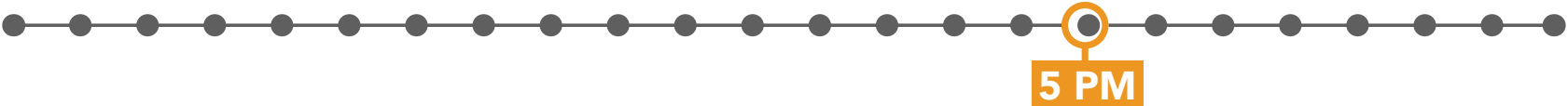

Figure 49: Startup Life Conference Room

STARTUP LIFE CONFERENCE ROOM

Shared conference rooms located in each coworking level gives entrepreneurs and startups professional spaces to meet with their clients. These conference rooms and professional services within the startup highrise gives entrepreneurs the benefits of a large Class A corporate office without the cost, long term commitment and risk.

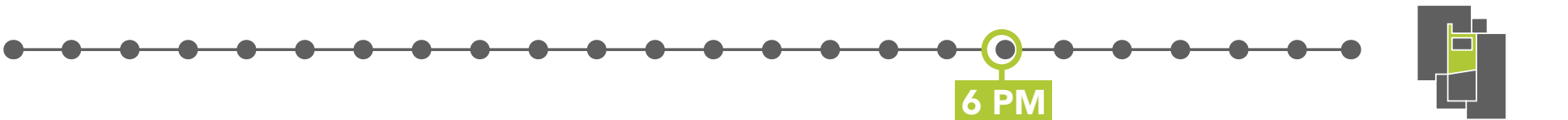

Figure 50: Startup Life Commons Cafe

STARTUP LIFE COMMONS CAFE

A cafe on the third level of each pod has a coffee bar and cafe for more of a lounge quiet lounge atmosphere for working during the business day. However, after the workday it can be used as the ideal space for hosting happy hours where entrepreneurs can socialize and interact with others who work in the tower and friends from outside of work.

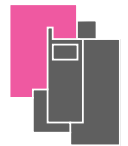
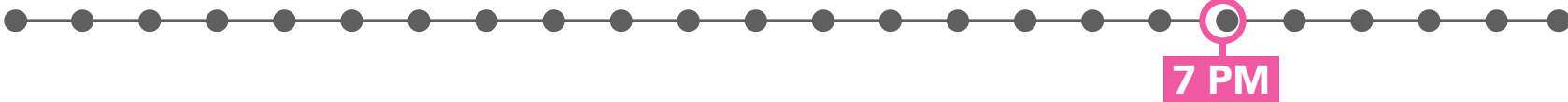

Figure 51: Startup Life Micro Unit

STARTUP LIFE MICRO UNIT

At the end of the work day entrepreneurs and startup founders can go to their private apartment units and close the door behind them, shutting out the noise and stress of their professional lives. Each unit has a balcony and sliding glass door so they can unwind at the end of the day and watch the sunset over the Olympic Mountains and Puget Sound.



Figure 52: Startup Life Skyline

CONCLUSION

This thesis set out to challenge the established live/work high rise typology to better enable interaction between living and work. By rearranging the program elements and introducing coworking office space instead of the typical shell and core/tenant improvement office model the proposed typology is able to create more flexible and shared spaces.

The end product is a dense live/work highrise that addresses the needs of startups while breaking down the scale to create a network of smaller communities and outdoor spaces. It also provides affordable housing and workspaces by rethinking the payment models to allow for common areas to generate revenue and entrepreneurs to exchange equity in their

company for discounted rent. This new reinvented live/work high rise typology is a vibrant vertical neighborhood that fosters the incubation and growth of Seattle's startups and entrepreneurs. At the end of the day, this thesis illustrates how small businesses and startups can carve out a piece of the Seattle skyline in an ever densifying city.

SOURCES

Arch Daily. "Google Campus / Jump Studios." ArchDaily. N.p., 07 May 2012. Web. 18 Dec. 2015.

Arch Daily. "Nagatino 2.0 Coworking Center / Ruslan Aydarov Architecture Studio." ArchDaily. N.p., 02 Apr. 2014. Web. 18 Dec. 2015.

Colao, J.J. "Eight Reasons Startup Incubators Are Better Than Business School." Forbes. Forbes Magazine, 12 Jan. 2012. Web. 26 June 2015.

Cook, John. "Seattle Ranks 4th as Global Startup Hub." GeekWire. GeekWire, 20 Nov. 2012. Web. 22 June 2015.

Coworking Wiki. "What Is Coworking?" Coworking Wiki. Coworking Wiki, 17 Mar. 2013. Web. 26 June 2015.

Forbes Entrepreneurs. "Why More Startups Should Move Downtown." Forbes. Forbes Magazine, 08 Dec. 2014. Web. 26 June 2015.

Foertsch, Carsten. "Coworking: Half the Cost of a Traditional Workstation." Coworking: Half the Cost of a Traditional Workstation. Desk-mag, 08 Dec. 2012. Web. 26 June 2015.

Gardner, Matthew. "Real Estate Research." UW Intro to Real Estate. Gould Hall, Seattle. 12 Apr. 2015. Lecture.

Guzman, Monica. "Should You Be Coworking? New Seattle Space Signals Shift." The Seattle Times. The Seattle Times, 11 Jan. 2014. Web. 26 June 2015.

Idea 1. "Idea 1 San Diego Startup Housing." Idea 1 San Diego. Idea District, 24 Sept. 2014. Web. 18 Dec. 2015.

Intuit. "Intuit 2020 Report." Intuit.com. Intuit, 31 Dec. 2010. Web. 05 June 2015.

Joyner, Jeffrey. "What Is a Live-Work Unit?" Small Business. Small Business Chron, 011 May 2013. Web. 26 June 2015.

McDermott, John. "Report: 75% of Venture-backed Start-ups Fail." Inc.com. Inc.com, 02 Sept. 2012. Web. 26 June 2015.

National Low Income Housing Coalition. "Out of Reach Report Graphics: National Low Income Housing Coalition." National Low Income Housing Coalition. National Low Income Housing Coalition, 01 Jan.

NBIA. "NBIA Incubator Annual Report." NBIA. National Business Incubator Association, 11 July 2014. Web. 26 June 2015.

Partovi, Hadi. "Is Seattle Silicon Valley's Next Favorite Stop?" TechCrunch. TechCrunch, 25 Apr. 2015. Web. 22 June 2015.

Rent Jungle. "Find Apartments in Your Area." Average Rent In Seattle, Seattle Rent Trends and Rental Comps. Rent Jungle, 01 Jan. 2015.

"Seattle/Bellevue/Everett Metro Area." U.S. Bureau of Labor Statistics. U.S. Bureau of Labor Statistics, 31 Dec. 2015. Web. 26 June 2015.

Shah, Dharmesh. "12 Facts About Entrepreneurs That Will Likely Surprise You." 12 Facts About Entrepreneurs That Will Likely Surprise You. On Startups.com, 21 Sept. 2009. Web. 26 June 2015.

Tan, Thanh. "Seattle's Co-working Spaces Nurture Ideas." The Seattle Times. The Seattle Times, 12 Sept. 2013. Web. 26 June 2015.

Vincent, Roger. "Feeling at Home in a 'live-work' Unit." Los Angeles Times. Los Angeles Times, 26 Aug. 2007. Web. 26 June 2015.

WeWork. "Coworking Office Space in Seattle | WeWork South Lake Union." WeWork. N.p., n.d. Web. 26 June 2015.