

NOTE TO USERS

This reproduction is the best copy available.

UMI[®]

The Validity of Student Self-Reports About the Effectiveness of
Graphing Calculators in an Undergraduate Mathematics Classroom

Andrew Allen Grzadzielewski

a dissertation submitted in partial fulfillment
of the requirements for the degree of

Doctor of Philosophy

University of Washington

2005

Program Authorized to Offer Degree:
College of Education

UMI Number: 3178143

INFORMATION TO USERS

The quality of this reproduction is dependent upon the quality of the copy submitted. Broken or indistinct print, colored or poor quality illustrations and photographs, print bleed-through, substandard margins, and improper alignment can adversely affect reproduction.

In the unlikely event that the author did not send a complete manuscript and there are missing pages, these will be noted. Also, if unauthorized copyright material had to be removed, a note will indicate the deletion.

UMI[®]

UMI Microform 3178143

Copyright 2005 by ProQuest Information and Learning Company.

All rights reserved. This microform edition is protected against unauthorized copying under Title 17, United States Code.

ProQuest Information and Learning Company
300 North Zeeb Road
P.O. Box 1346
Ann Arbor, MI 48106-1346

University of Washington
Graduate School

This is to certify that I have examined this copy of a doctoral dissertation by

Andrew Allen Grzadzielewski

and have found that it is complete and satisfactory in all respects,
and that any and all revisions required by the final
examining committee have been made.

Chair of Supervisory Committee:



Francis P. Hunkins

Reading Committee:



Francis P. Hunkins

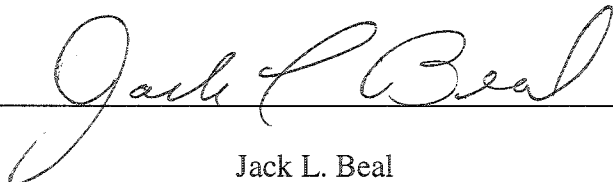

Jack L. Beal



Stephen T. Kerr

Date: 5/12/2005

In presenting this dissertation in partial fulfillment of the requirements for the doctoral degree at the University of Washington, I agree that the Library shall make its copies freely available for inspection. I further agree that extensive copying of the dissertation is allowable only for scholarly purposes, consistent with "fair use" as prescribed in the U.S. Copyright Law. Requests for copying or reproduction of this dissertation may be referred to Proquest Information and Learning, 300 North Zeeb Road, Ann Arbor, MI 48106-1346, to whom the author has granted "the right to reproduce and sell (a) copies of the manuscript in microform and/or (b) printed copies of the manuscript made from microform."

Signature Andrew G. G. G. G.
Date 5/12/2005

University of Washington

Abstract

The Validity of Student Self-Reports About the Effectiveness of
Graphing Calculators in an Undergraduate Mathematics Classroom

Andrew Allen Grzadzielewski

Chair of the Supervisory Committee:
Professor Francis Hunkins
Department of Curriculum and Instruction

Nineteen undergraduate mathematic students from three Pre-Calculus classes were observed during class meetings, in lab sessions, and in one-on-one interviews. The study used a qualitative methodology to consider the validity of their attitudes toward their graphing calculators. In the interview sessions, students talked about classroom problem solving situations and also solved mathematics problems posed by the researcher with the use of think-aloud commentaries. Findings suggest that students' beliefs about the effectiveness of their graphing calculators in helping them learn and retain mathematical ideas and concepts are often suspect, and that researchers who rely on this type of student input need to be wary of its validity. Thus, the study calls into question the effectiveness of surveys as an instrument for determining whether or not students benefit from the use of graphing calculators, especially if such instruments are the only tool used to gauge student calculator perceptions. Finally, the researcher postulates that assessment practices of the instructors participating in the study were naïve in that these assessments allowed many students to use the graphing calculator in ways that caused the instructors to believe that the students knew more about class topics than they actually did.

TABLE OF CONTENTS

List of Figures.....	iii
Chapter I: Technology Tools Past And Present.....	1
Technology in the Past.....	3
A Different Kind of Calculator.....	7
Suggestions From Researchers.....	8
Statement of the Problem.....	12
Why caution may be in order.....	15
Conclusion.....	21
Chapter II: Literature Review.....	22
Beyond Achievement.....	24
Student Perceptions.....	27
Potential Difficulties.....	32
Conclusion.....	36
Chapter III: Methodology.....	38
Data Collection.....	40
Interview Methodology.....	41
Conclusion.....	48
Chapter IV: Results.....	50
Research Question 1.....	52
Research Question 2a.....	65
Research Question 2b.....	100
Research Question 3a.....	105
Research Question 3b.....	113
Research Question 4.....	114
Conclusion.....	116

Chapter V: Discussion and Implications	118
Poor Retention of Calculator Procedures.....	120
Naïve Assessments	136
High-School Experiences	149
Implications for Researchers.....	150
Implications for Teachers	155
Suggestion for Further Research.....	165
Possible Limitations of the Study	165
Conclusion	168
Bibliography	169
Appendix A: Author’s Previous Research	178
Appendix B: Questions to be “Seeded” on Homework.....	179
Appendix C: Exit Interview Calculator Questions	183
Appendix D: Exit Interview Problems.....	184
Appendix E: Programmable Calculator Web Site.....	185
Appendix F: Description of Supersubjects.....	186
Appendix G: The Fascinating Case of Quentin	196
Appendix H: An Unreported Creative Use	202

LIST OF FIGURES

Figure Number	Page
1. Steve's paper work.....	53
2. Steve's calculator work on the above problem.....	54
3. Steve work on another problem.....	55
4. Steve and the Rectangle Problem	56
5. Steve's calculator image on a quadratic equation.....	57
6. Steve's paper work on the above quadratic equation.....	58
7. Kyle's work on the square root equation	60
8. Kyle's first calculator image on the cubic equation problem	62
9. Kyle's second calculator image on the cubic equation problem.....	63
10. Nancy's work on a linear equation	68
11. Rita's work on a linear equation	70
12. Darla's work on a linear equation.....	72
13. Greg's work on a slope problem.....	74
14. Greg's work on another slope problem.....	75
15. Freda's work on a minimization problem.....	76
16. Isaac's work on the Fahrenheit and Celsius problem	78
17. Janet's work on a quadratic equation.....	80
18. Janet's work on a distance problem.....	82
19. Janet's work on a system of equations problem	83
20. Michele's work on a simple equation	86
21. Michele's work on a percent problem	88
22. Paula's work on a system of equations problem.....	90
23. Linda's work on a logarithm problem	93
24. Oliver's work on a logarithm problem	96
25. Cathy's work on an exponential growth problem.....	98
26. Alex's work on a logarithmic equation.....	101

27.	Researcher's use of the calculator while with Alex.....	102
28.	Helen's work on a linear equation.....	107
29.	Helen's work with a calculator corroborating an answer.....	108
30.	Helen's work solving a quadratic equation.....	109
31.	Helen's work with a calculator corroborating another answer.....	110
32.	Helen's work on a line.....	111
33.	A student misunderstanding of calculator output.....	116
34.	Janet's work on a quadratic equation.....	122
35.	Freda's work on a minimization problem.....	123
36.	An example of calculator non-retention.....	124
37.	Another example of calculator non-retention.....	125
38.	Another example of calculator non-retention.....	126
39.	Another example of calculator non-retention.....	127
40.	The graph of a parabola.....	128
41.	Student work on a quadratic equation.....	129
42.	Student work illustrating a forgotten calculator procedure.....	130
43.	Student work illustrating a forgotten calculator procedure.....	131
44.	Student work illustrating a forgotten calculator procedure.....	131
45.	Student work illustrating a forgotten calculator procedure.....	131
46.	Student work illustrating a forgotten calculator procedure.....	132
47.	Student work illustrating a forgotten calculator procedure.....	132
48.	Student work illustrating a forgotten calculator procedure.....	133
49.	Student work illustrating a forgotten calculator procedure.....	133
50.	Student work illustrating a forgotten calculator procedure.....	134
51.	Student work illustrating a forgotten calculator procedure.....	134
52.	Student work illustrating a forgotten calculator procedure.....	135
53.	Nancy's work on lines.....	139
54.	Rita's work on lines.....	142
55.	Michele's work on a simple equation.....	144

56. Isaac's work on the Fahrenheit and Celsius problem	145
57. Linda's work on a logarithm problem	146
58. Cathy's work on an exponential growth problem.....	147
59. Rita's work on lines	151
60. A student work on the distance formula	160

Chapter I

TECHNOLOGY TOOLS PAST AND PRESENT

Starting in the late 1980s, and continuing on into the new century, mathematics teachers have had multiple opportunities to introduce new technologies into their classrooms. Computer algebra systems have been designed to help students solve equations and to aid them with algebraic manipulations. Other computer programs have been developed to help students better visualize geometric concepts by making it easier and faster to draw and interpret geometric figures. A powerful new class of spreadsheets has arisen, including some with built-in mathematical functions and powerful programming languages. Graphical calculators now give students the capability to manipulate algebraic expressions and solve certain types of equations and give both teachers and students the ability to display 2-dimensional and even 3-dimensional graphs. Manufacturers of these graphical calculators have continued to add more capabilities to their products, recently including the ability to use the Internet to download programs designed to perform various mathematical procedures.

The availability of these new technology tools has undoubtedly given teachers and students the opportunity to interact in ways which were previously impossible. But it has become almost trite to point out that these new interactions may not necessarily enhance efforts to improve the performance of mathematics students. As more and more

technology tools become available, teachers are commonly faced with some very important questions. For example, is there any evidence to demonstrate that such tools will really benefit the students? Is it possible that it would be wise to use the technology in some situations, but not in others? How will the students react to the introduction of a new technology? Will the time the teacher and students inevitably spend learning how to use the technology pay off? Will it help all the students, or just some? Is it possible that the new technology will impair the achievement of some students? How thoroughly should the teacher feel obligated to investigate the new technology before using it in the classroom? How thoroughly should policy makers investigate before encouraging (or discouraging) teachers to use them? Finding the answers to these and many other questions is an ongoing struggle for mathematics teachers, and for those who train and support them. This is particularly true given the fact that new technologies, and enhancement of existing technologies, seem to arrive at an ever increasing pace.

Researchers have, of course, recognized the need to help mathematics instructors and policymakers answer these questions. Preliminary research studies have indicated that newer technology tools, particularly spreadsheets and graphing calculators, have the potential to improve the way mathematics is taught and learned (Demana and Waits, 1990, Dunham and Dick, 1994). Researchers often give reports of teachers who speak enthusiastically of their experience using new technology tools. (West, 1991, Simonsen and Dick, 1997). Surveys of students often indicate that they feel their mathematics

experience is enhanced when using tools such as graphing calculators and computer software. (McClendon 1992, Meel, 1997). Tens of thousands of teachers have embraced the new technologies, and some school districts have reorganized their entire mathematics curriculum around new technologies. Other teachers and districts have been slower to change, citing lack of funding, philosophical conflicts about the nature of mathematics education, or the higher priority of other issues (Bond, 1988). Because of the appearance of new technologies, and the enhancement of current ones, the debate about student and teacher use of technology in mathematics classrooms will likely continue indefinitely.

Technology in the Past

The current spotlight on technology tools and the struggle with how best to use them in mathematics classrooms actually obscures the fact that, for the better part of a century, coping with new technology tools and attempting to maximize their potential have been common challenges for both mathematics teachers and students. For example, starting in the 1920s, mechanical calculating machines began to become available to classroom teachers. Though crude and clumsy by modern standards, their arrival nevertheless generated heated debate about how and if they should be used in classrooms (Webb, 1921; Nygaard, 1934). From the 1930s through the 1960s, the debate continued as many other

technological aids became available, such as the angle mirror, place value boards, filmstrips, standard and circular slide rules, and many others. Again, teachers and researchers questioned not only when and how to integrate these tools into classrooms, but even if they should be used at all (Gorsline, 1933; Bush, 1934). To help introduce teachers to these new tools and to offer suggestions on their use, the journal Mathematics Teacher, published by the National Council of Teachers of Mathematics, began publishing several monthly series articles. One series was entitled “Devices for a Mathematics Laboratory,” and another was called “Aids to Teaching.” In fact, the spirit of the latter series still lives in the current issues of Mathematics Teacher and is now entitled “Technology Tips.”

In the late 1960s and early 1970s, the first four-function calculators (which could perform addition, subtraction, multiplication and division) came onto the scene. Teachers again faced difficult decisions about how and if to use these new devices, and the debate continued. Many felt that these calculators could ruin students’ number sense and arithmetic skills; others thought the best course would be to delay using the calculators until more was known about their impact. Of course, there were those who thought this new technology would be helpful, if used “appropriately” (Machlowitz, 1976, and Gaslin, 1975).

Interviews of teachers whose careers spanned this time period reveal that the lack of compelling research on either side of the issue generally complicated

each teacher's decision as to how to proceed. Beginning in the early 1980s, scientific calculators appeared, armed with logarithms and trigonometric features. Many teachers had the embarrassing experience of seeing these for the first time when a student brought one to class (this writer included). Some teachers felt that students should still use logarithm and trigonometry tables (or slide rules!), while others said that the time saved by finding these values on the calculator could be more profitably spent in other mathematical pursuits.

In the 1980s, computer software such as computer algebra systems, and spreadsheets, such as Microsoft Excel, emerged. Teachers already feeling a time crunch were asked to learn yet another set of skills. Unfortunately, schools often did not provide teachers with the time they needed to learn these new skills, and training personnel were often scarce or nonexistent (Harry, 2000). Because they were often expected to incorporate the new technology into their lessons, many commonly spent their own time learning new software skills and created their own technology lessons with little or no guidance. Also, many teachers struggled alone with important issues such as software installation and reinstallation, file storage, file backup, convenient student access to practice files, and software upgrades. An even more difficult issue was to what extent the software should be used. Should it be used for this unit and not for that one? Even teachers who spent countless hours learning new software programs on their own and many more hours revising their lessons to include these programs were

sometimes foiled when there was a software glitch or when the equipment broke down, and there was no resource person to fix it or replace it in a timely manner (Bond, 1988). Despite ongoing research on the effectiveness of computer software in mathematics classrooms, teachers often point out that it is still unclear as to exactly what to do with this software and when to do it. Classroom teachers frequently make unilateral decisions about when and if to use this software. Of course, in the midst of all this, there have, and continues to be, those who question whether such software should even be used at all in a mathematics classroom, whether it contributes to student learning, and whether time spent learning and using computers could be better spent doing something else. A further frustration with the appearance of personal computers occurred when teachers first recognized the need to update their skills to accommodate new versions of the software. It is not uncommon for teachers to encounter upgrades to an educational software package once a year, sometimes even more often. Many schools did not anticipate and plan for this contingency in their training plans, thus making incorporation of these new technologies even more challenging (Harry, 2000).

As each new piece of technology has appeared, mathematics teachers have had to decide anew how best to embrace it. It is not just in the past few years that mathematics teachers have had to cope with new technology tools; as indicated previously; it has been going on for at least a century. However, recently teachers have begun to receive more help in answering difficult questions about whether and to what extent to utilize

these classroom tools. Increasing research has begun to provide teachers with information about technology tools. This is particularly true in the case of a new technology tool that appeared in the late 1980s. That tool is the graphics, or graphing, calculator.

A Different Kind of Calculator

As noted before, the first handheld calculators performed addition, subtraction, multiplication, division, and eventually extracted square roots. Then came “scientific calculators,” which provided trigonometric ratios, logarithms, and calculated powers and roots. Later models performed statistical calculations, stored numbers in memory for later use, and even performed fractional arithmetic. Graphing calculators, recently the topic of intense research, differ from their earlier cousins. They allow:

- Algebraic expressions to be manipulated and simplified by the user.
- Approximate (or exact) solutions to be given for certain equations.
- Hundreds of variables and programs to be stored in permanent memory
- A view screen to permit the user to graph and manipulate many standard mathematical functions; a zoom feature allows the user to see the function from multiple perspectives.
- Data points to be stored and an approximate graph to be created easily.
- Three-dimensional graphs to be approximated on the screen’s two dimensions.
- Advanced calculations such as integration and differentiation to be performed.
- Built-in programming languages to be used to mimic mathematical algorithms such as the quadratic formula or Newton’s method.

Moreover, programs can be shared between calculators with the aid of a special cable and can even be downloaded from the Internet. And newer calculators offer even more features via upgrade cards and various add-ins and even memory upgrades.

However, there is something unique about the current situation. These extremely powerful graphing calculators have appeared during a period of intense interest in mathematics education reform. Many researchers in the mathematics education community have made these calculators a major emphasis of their research, looking for evidence of their effectiveness and searching for ways to maximize their use. In the past, a teacher might decide for himself or herself how and if to use technology tools in the classroom. In recent years, however, researchers have spent significant time and effort investigating graphing calculators, coming forward with suggestions as to how and when to employ these calculators. Some researchers have been quite specific discussing the potential impact of these tools on issues such as pedagogy, curriculum, and equity. Teachers no longer are alone in determining the extent to which technology may assist themselves and their students.

Suggestions from Researchers

Citing researchers who have investigated the use of these graphing calculators, the National Council of Teachers of Mathematics (NCTM) has, for more than fifteen

years, been encouraging teachers to integrate the use of graphing calculators into their classrooms. This includes using the calculator on an overhead screen to enhance lectures and demonstrations, having each student use one to follow along with the teacher during lessons, as well as for use by students during various activities such as group work during class time, day-to-day homework, projects, and even for use on quizzes and examinations. In order to justify these recommendations, the Council has pointed to research studies which claim that the use of graphing calculators has the potential to significantly improve the teaching and learning of mathematics. These claims are based on results such as increased achievement scores on tests of conceptual understanding, better student attitudes toward mathematics, improved student problem solving skills, increased student involvement in classroom discussion, and an increase in student-to-student dialogue (NCTM, 1989 and 2000).

Many researchers have echoed the sentiments of the NCTM, agreeing that the benefits of integrating graphing calculators in the mathematics classroom are significant, perhaps even dramatic. However, even researchers favoring the increased use of graphing calculators in mathematics classrooms point out that there is still additional research necessary. For example, one research duo presented the following list of important unresolved questions:

Do some students benefit more from the use of the graphing calculators than others?

Are certain topics better explored with aid of a graphing calculator?

Is student retention of mathematical concepts improved?

Which aspects of graphing calculators bring about improved understanding?

What paper-and-pencil skills will retain their importance?

Can using this technology sometimes impede understanding? Under which circumstances?

Does graphing technology promote any new errors or misconceptions?

Since the occasional study finds either a neutral or negative impact, what accounts for the difference between success and failure in implementing the use of graphing calculators?

(Dunham and Dick, 1994)

Research studies reporting positive results in mathematics classes which used graphing calculators, such as an overall increase in test scores, cannot necessarily explain why the calculators had this positive effect. For this reason, researchers have been calling for additional research that looks into the details of student and teacher calculator use. For example, after finding evidence that students using graphing calculators had significantly higher scores on a final exam than a control group in a Pre-calculus class, Dunham and Dick (1994) called for continued research on precisely what about these calculators is causing the difference. As late as 1999, after surveying more than a decade of mostly positive research on the use of graphing calculators, Milou (1999) wrote that “research into graphing calculators is in its infancy.” He posited that much more research is required to better understand the interaction between graphing calculators and the classroom environment.

As mathematics education researchers begin investigating *what* makes graphing calculators helpful in the mathematics classroom, they are finding many worthwhile questions. For example, can we discover specifically what students (and teachers) do with them that *improves* student performance? Are certain types of students more likely to benefit? Are there ways in which calculators are used which are not beneficial or even counterproductive? How will teachers and students come to know how to avoid these behaviors? Is it possible to discover which types of students are most likely not to benefit? Also, how should research be structured to uncover this information?

Answering these questions will clearly require more qualitative studies, studies that focus on individual students and teachers and the way they employ calculators in specific instances. Past quantitative studies have revealed that graphing calculators have a positive overall effect on groups of students. While the overall effect is seen to be positive, deeper questions arise as to how individuals are influenced by calculator use. Only looking at overall group performance of groups may make it difficult if not impossible to discover the effects on individuals. Focusing on individual stories may be more enlightening and more fruitful.

Statement of the Problem

As researchers begin to uncover reasons why graphing calculators prove either helpful or harmful, they are also finding new ways to search. One approach that is becoming more common is the solicitation of student input (Ponte and Canavarro, 1993; Dunham and Dick 1994; Wilson and Krapfl, 1994). In these studies, students are asked, either through a survey instrument or an interview process, their opinions and/or perceptions regarding their calculator use. They might be questioned as to whether or not they thought the calculator helped them to understand certain topics, or whether the calculator gave them a better attitude toward mathematics. These data are then used in an effort to determine the effectiveness of such calculators. Part of the reason that this technique is gaining ground is the recognition that students' perceptions and attitudes have been underutilized in mathematics research, and that this rich mine of data has the potential of improving our understanding of technology tools (Grouws and Cebulla, 2000).

For example, many researchers have pointed out that such student input has helped them to sharpen their research focus when investigating graphical calculators. They speculate that student input has in part indicated that certain types of both student and teacher behavior may help increase the positive impact of calculators in the classroom. Dunham & Dick (1994) found via student input that:

- Students believed that even though some class time is used up in doing so, the investment in class time to gain familiarity with the calculators pays off in the long run.
- Students value an initial familiarization calculator training process so that when the lesson focus turns to the actual mathematics there was less inclination to experiment with irrelevant functions.
- Students felt that being encouraged to make good use of their estimating skills minimized the possibility of accepting incorrect answers caused by inevitable input errors.
- Students believed that reorganization of the classroom around a graphing calculator promoted discussion and exploration.

Szetela & Super (1987) utilized student interviews in their research, reporting that students who used graphing calculators often had a better attitude toward problem solving situations than those who did not use such calculators. In another example, Ponte and Canavarro (1993) made student perceptions of their graphing calculators the main focus of their research study, and also found that students had a generally positive view of their calculators.

As more researchers begin to solicit student input in their research projects, the question naturally arises as to the validity of such input. Some researchers seem to conclude that if students comment positively on the use of a graphing calculator, then the calculator was helpful. Is this a wise conclusion? If a student believes that a graphing calculator was helpful, was it really? To what extent can this input be trusted? To what degree can such input be meaningful and/or trustworthy? Is it possible that a

student's belief about the usefulness of a graphing calculator may be suspect? If so, could it lead to incorrect conclusions about the usefulness of such tools?

Some researchers have commented on this difficulty with student self-analysis of their calculator usage. For example, Szetela & Super (1987) found a better attitude among students toward problem solving when the calculator was used despite test scores not being significantly higher for those students when compared to their counterparts who did not use a calculator. In a study with geometry students, Schoenfeld (1988) found that students felt quite confident about their calculator skills and still did not grasp the topics in question. In a recent research study, this writer (as well as many of my colleagues in other settings) have sometimes found that students with almost zero understanding of a concept nevertheless commented as to how critical the calculator was in helping them to understand this same concept (See Appendix A).

On the other hand, is it conceivable that a negative or neutral attitude toward a graphing calculator could be an invalid student conclusion? Is it possible for a student not to remember or appreciate the help he/she received from the calculator? Is it possible for a student to be affected positively by a calculator, but subsequently report it was of no use? For example, could a student benefiting from classroom demonstrations using a graphical calculator fail to identify this in his/her conclusions about its usefulness, especially if the student's use of the calculator outside of class was minimal?

Might a student observed using the calculator in ways that clearly helped him or her to understand mathematical concepts and procedures report that their calculator had not helped them?

Why Caution May Be in Order

Take two typical examples of research projects in which the researcher found an increase in achievement, and at the same time, found that most students spoke favorably about the usefulness of graphing calculators. O'Callaghan (1998) studied nine sections of a Pre-Calculus course in which six sections used graphing calculators and three did not. Each of the three instructors taught two sections of students using the graphing calculators and one section of a control group in which the students did not use graphing calculators. Students using the graphing calculators were found to have higher test scores than those in the control groups. In a survey administered at the end of the classes, they also reported a better attitude toward mathematics and more enjoyment of the class. Similarly, Wilson and Krapfl (1994) noted positive student beliefs about their graphing calculators and also found increased achievement in tests versus a control group that did not use the graphical calculators.

A common conclusion reached in such cases is that since the students made positive comments about the calculators, and since achievement increased, the

calculators were at least part of the cause of the increased achievement. But is this necessarily the correct conclusion? Could the student beliefs be misleading even given the reported gains in achievement? Is it possible that a student could report positive beliefs about the usefulness of his/her calculator, but such beliefs prove misleading?

Consider the following scenarios:

Is it possible that the assessments in the course may have been inappropriate, leading to students using the calculator to give evidence of improved achievement, where little or none really existed? This could happen if the assessment was not thought out well enough, and students were able to answer questions on topics that they really didn't understand, but that the calculator may have helped them answer. Also, is it possible that the presence of the calculator provided the teacher with alternative forms of teaching unrelated to student use of the calculator? The teacher's exposure to the calculator may have altered his/her way of teaching, and his/her own attitudes toward the subject. This could be especially unfortunate, because instead of a pedagogical shift getting the credit, the researcher may attribute the improvement to student use of the calculator.

Another possibility: students' positive attitudes may have come from the fact that the student felt that the technology allowed him/her to better "see" the representation that the teacher had in mind, kind of like a dynamic chalkboard. But Connell (1998) found that if students are not using the technology to create representations that were

personally meaningful, it wasn't useful. In other words, the technology tool simply used as a delivery system of the static "expert" representation of the teacher may inhibit the student from developing his own meaningful representation. This, and a combination of naïve assessments may lead the researcher to wrongfully attribute any improvement to the calculator. Students may learn a topic superficially, possibly giving some evidence of improved achievement, which may be fleeting.

Also, is it possible that in a class where the majority of students has attained increased achievement and report a positive experience with their calculators, there may exist a significant minority of students who have learned little mathematics, but also have a positive attitude toward their calculators? In other words, can a situation exist in which certain students are not benefiting from the use of their calculators, even though the majority is? Certainly we do not want to discount those students who may not really be learning, but whose poor performance is being hidden in among the larger group. Conscientious mathematics teachers would want to know of such students "hiding" in the crowd and would certainly like to identify and help these students.

Could some increases in performance noted in the literature be due to a Hawthorne effect, in which students, aware of the experiment, perform better? Finally, is it possible that something as simple as a miscommunication could confound the data? Consider the following possibility: An interviewer, upon hearing the student talk about

the usefulness of the calculator in solving a calculus problem, may envision the student exploring derivatives, finding inflection points and drawing dynamic graphs, but the student may simply have meant that he/she used the calculator to perform simple arithmetic. Is this not possible in a situation in which the researcher used an instrument such as a survey instead of conducting in-depth interviews which may have revealed that what the investigator thought was happening really wasn't?

In short, despite an overall positive effect on achievement, there may be a significant minority of students who see an incomplete (and perhaps misleading) portrait of their mathematical progress and thus are inhibited from making adequate progress because their use (or the teacher's use) of graphing technology is inappropriate or inadequate. It may be difficult to identify such students with normal quantitative means, especially when viewing the achievement of mathematics classes as a whole. Hopefully, the contribution that this study will make is to provide other researchers (and this researcher) with some insight into how valid student input can be expected to be regarding the effects of graphing calculators on learning mathematics. Teachers who are enthusiastically using these tools certainly need to be aware of any limitations that may exist when assessing student feedback about the use of these calculators. Perhaps there are things that can be learned to help identify those students more likely to give potentially misleading information about the true nature of the help that their calculators provided. Researchers need to be aware of how much faith they can place in the

students' opinions and beliefs regarding the effectiveness of calculators in helping them understand and achieve.

Teachers with many years of experience teaching mathematics have little doubt that sometimes students are confused about the role and capabilities of their graphing calculators. Any math teacher can provide an anecdote about a student who will proudly proclaim that his/her calculator has given the right answer when in fact the student is wrong, often by an order of magnitude. It is certainly not unusual for a teacher and a student to have differing views about the appropriate use of graphing calculators. It will certainly not be news if this researcher finds students who are confused about their calculator. Incidental misuse of a graphing calculator, or non-optimal use is commonplace, as every math teacher knows. However, is this merely the exception, or an indication of a larger issue with students' perceptions of their calculators? The questions persist: Is it wise to take a general student satisfaction with their calculators as evidence that the calculators are behind improved student performance? Do we know how often student input turns out to be invalid or misleading? To what extent can student input be trusted as a valuable diagnostic tool for the researcher?

Influenced by previous and current research, this investigator has generated the following research questions for this study.

- 1) What fraction of students have **valid** perceptions about the effectiveness of their calculator in helping them understand class topics? Do they have anything in common that would help researchers/teachers be aware that their perceptions are valid?
- 2) Are there students who feel the calculator is helping them to understand class topics but in reality:
 - a) they do not understand the topic as clearly as they claim?
 - b) they came to an understanding of the topic, but the calculator was of little use to them in doing so?
- 3) Might a student maintain the calculator was **not** useful in learning a certain topic but in reality:
 - a) the student was actually observed using the calculator in substantive ways, but may have dismissed such uses or forgotten them?
 - b) the calculator may have been used by the **instructor** in ways that facilitated student learning, but such usage was not reported by the student?
- 4) Do the students referred to in questions 2 and 3 have anything in common that would help researchers (and teachers) be aware that some student perceptions may be suspect?
- 5) For any of these types of students, what implications are there (if any) for research studies concerning the effectiveness of graphing calculators?

Conclusion

As newer technology tools continue to become available to mathematics teachers and their students, inevitably questions and concerns arise which may not have been faced in the past. For example, graphing calculators tend to be more expensive than other technology tools, and cost may be a real issue for some districts and/or students. These calculators also have features which previous tools did not have, such as a view screen for viewing graphs and a built in programming language, which may bring up possibilities for use that did not exist before. Graphing calculators have multiple features; is it appropriate to use some features and not others? Yet some questions raised by the availability of graphical calculators are similar to those raised by tools of the past. Are such tools really necessary? Could we do just as well without them? Might some students benefit more and some less from their use? Should we use such tools at certain times and not at others? Will the time spent training the teacher and the students to use a new tool be worth it? Should we use it just because it exists or should we wait for research to “prove” which ways are useful? And finally, how can we judge the validity of student perceptions of a particular tool, in this case the graphing calculator?

Chapter II

Literature Review

Early research into the effects of graphing calculators on classroom learning were experimental studies in which classes not using graphing calculators were compared with those that were. Often they compared classes in the same school or even different sections of the same mathematics class. Harvey (1993) found significant differences in favor of experimental groups utilizing graphing calculators, analyzing data from a field test of a graphing-intensive curriculum, the Computer and Calculator in PreCalculus Project. He compared average scores on a calculus readiness test for fifty-five schools using graphing technology in Precalculus courses with the test scores of twenty-two control schools with traditional precalculus courses. Using the same test in each class, he found statistically significant differences in achievement favoring the experimental groups using the graphing calculators. Quesada and Maxwell (1992) studied the effect of graphing calculators in Pre-Calculus classrooms and found significant differences in achievement on tests in favor of the experimental groups that utilized graphing calculators. Quesada and Maxwell (1994) followed 710 Pre-Calculus students through three academic semesters. On comprehensive common final exams, students using the graphing calculators had significantly higher scores than those in the control groups.

Harvey, Waits and Demana (1995) used the results of five mathematics tests from over 1500 high school students and reported that the experimental groups, which used graphing calculators, outperformed the control group on all five tests. Thompson and Senk (2001) compared four high school algebra classes (each with about twenty-five students) within the same school. Two classes used an exploratory, problem-solving-based reform curriculum utilizing graphing calculators; the other class used a traditional curriculum. Two teachers each taught one class with graphing calculators and one without. At the end of the school year, the researchers administered a posttest focusing on core curriculum content. Students in the two reform classes who used the graphing calculators significantly outperformed students in their comparison classes who did not have access to graphing technology.

Experimental studies have indicated that most, if not all, mathematics subjects have the potential to be positively impacted by the use of these tools. Research such as that by Heid (1997), Marshall (1996), and Penglase and Arnold (1996) indicate increased achievement (test scores) in trigonometry, calculus, and statistics. Other researchers see similar results for algebra and pre-calculus (Dugdale, et al., 1995 and Ruthven, 1990).

Beyond Achievement

In addition to the experimental studies focusing on student achievement (most often measured by test scores), many research studies focus on changes in classroom dynamics and pedagogy. Farrell (1996) used videotapes of six lessons from each of six teachers and coded teacher and student roles into six categories: manager, task setter, explainer, consultant, fellow investigator, and resource. The evidence suggested that students and teachers shifted their roles when technology was in use. She found that teachers who utilized graphing calculators in their classrooms were more likely to pursue student interaction and comment, and they felt as if students were more comfortable taking a more active role in the classroom. She also noted that students were more comfortable forming their own hypotheses and made more generalizations. Hylton-Lindsay (1998) claimed that graphing calculator use enhances student metacognition and encouraged students to self-regulate their thought processes.

Slavit (1994) observed high school Algebra students who did not use graphing calculators in Algebra I, but used them in Algebra II. He maintained that when students began using graphing calculators, they were more involved in classroom discussions than in the past and were more likely to experiment with the help of the calculator if they were stuck. The students also reported in a survey that the calculators helped them better understand the course material. Crocker (1991) found that university calculus

students with access to calculators were more likely to experiment and try varied approaches to problems. Chandler (1993) reported a significant increase in understanding and achievement of high school students related to the fact that graphing calculators allowed the students to visualize their work. In a four month study of 261 mathematics and science teachers, Tharp et al. (1997) maintained that the presence of graphing calculators in the classroom helped mathematics teachers begin to think of ways in which they could change the way they teach, rather than remain comfortable in an unchanging routine. They found that participants' views changed significantly in favor of viewing the graphics calculator "as a 'thinking tool' to enhance conceptual understanding and expand exploration." Milou (1997) surveyed 146 teachers in 61 schools who generally reported that the use of graphing calculators in Algebra I allowed for more detailed attention to difficult algebra topics and more intensive investigation of the concepts. Routine and tedious topics could be handled by the calculator permitting increased analysis of many topics such as statistics and data collection. Previously, such thorough investigations were felt by teachers to be out of reach because graphing functions by hand and performing tedious, but necessary calculations, took too much of the available class time.

Many researchers claim that graphical technologies are helping students to master topics which traditionally have been difficult for students to understand and retain. An example is the concept of function, a topic which many researchers and teachers have

long lamented as being a common stumbling-block for students. Rich (1991) and Beckmann (1989) both reported that students using graphing calculators outperformed control groups in their understanding of functions. Other researchers contended that students employing graphing calculators better understood the relationship between the algebraic representation and the visual representation of functions, developed better graph concepts, and were more likely to improve their problem solving skills (Harvey, Waits, & Demana, 1995). Hollar and Norwood (1999) compared performance of one hundred and twenty college students enrolled in two versions of an intermediate algebra course, one incorporating handheld graphing technology, the other not. At the end of the course, on a specialized test designed to assess conceptual knowledge of functions, they found that students in the group using graphing technology performed significantly better in modeling, translating, and interpreting functions. Ruthven (1990) compared the performance of two hundred students in advanced-level Pre-Calculus courses at four English secondary schools. Students who used the graphing calculators achieved significantly higher test results on items involving symbolization of mathematical functions. The experimental groups did better at both *recognition* (correct identification of the type of function) and *refinement* (finding the precise equation for the graph). Mingus and Grassl (1997) observed improved problem solving skills when graphing calculators were used in an undergraduate Pre-Calculus classroom when compared with a control group. In a meta-analysis of 24 studies, Smith (1997) reported significant

achievement differences in problem solving, computation, and conceptual understanding favoring students who used calculators versus those who did not.

In response to concerns that students working with graphical technology would experience atrophy of their basic skills, some researchers have studied potential negative effects. Hembree & Dessart's 1986 meta-analysis, mentioned earlier, found that in the case of four-function and scientific calculators, the basic mathematics skills of students were not found to be worse than students not using such calculators. Students who learned paper and pencil skills in conjunction with technology-based instruction and were tested *without* calculators performed as well or better than students who did not use technology in instruction. Other researchers have duplicated this result in the case of graphing calculators as well (Heid, 1997).

Student Perceptions

Students' general perceptions, views and attitudes regarding technology tools are increasingly seen as crucial factors affecting the effectiveness of such tools. In the pre-graphing calculator age, Hembree and Dessart (1986) conducted a meta-analysis of 79 studies from a 15-year period. Analyzing students' achievement and attitudes in calculator-enhanced settings, Hembree and Dessart conclude that students who used calculators possessed better attitudes and had better self-concepts in mathematics than

non-calculator users and that testing with calculators produces higher achievement scores at all grades and ability levels. Many researchers have also reported a positive effect upon student attitudes when the newer graphing calculators are used. Acelajado (2003) studied sixty-six students in two College Algebra classes who were utilizing graphing calculators. The results of a pre-test of standard College Algebra skills and the Mathematics Anxiety Ratings Scale (MARS) compared with a post-test revealed that the students felt that the availability of graphing calculators reduced their mathematical anxiety and increased their self confidence in solving mathematics problems. Keller and Russell (1997) noted that calculus students using a graphing calculator for problem solving were more successful, exhibited more metacognitive behaviors, and had greater confidence in their problem solving ability than did students without the graphing calculators. Branca et al., (1992) found that junior high school students were less likely to give up on a math problem if they had access to a technology which gave them hope that they wouldn't have to perform tedious calculations. They found that more realistic "real world" numbers such as population reports, government budgets, sports statistics, lottery prizes, and lawsuit judgments could be used instead of the contrived problems often seen.

Casey (2001) performed a case study of 23 students in a high school Environmental Studies class, whose primary task during the four month study was to collect and analyze environmental data such as temperature, atmospheric pressure and

temperature. With data gathered from observations and student interviews, he found that the graphing calculators used in the class helped students overcome frustrations in analyzing and plotting graphs of data, and provided assistance when students attempted to derive a mathematical relationship for their data. He also found that the instructor believed the calculators created more opportunities for students to interact with one another, a stated goal of the instructor.

Dunham and Dick (1994) also reported a positive effect on student attitudes (and achievement) when using graphical technology. They looked at fifty students in two high school algebra classes where content, instruction, and testing were identical; the only difference being the presence of graphing calculators in one of the classes. The students utilizing the graphing calculators displayed better graphical understanding, the ability to link equations with their graphs, could more effectively read and interpret graphical information, were able to obtain more information from a graph, were successful at finding algebraic representations of a graph, and could better understand global features of functions as a whole. They maintained that many students who use graphing technology:

- placed at higher levels in hierarchy of graphical understanding
- were better able to relate graphs to their equations
- could better read and interpret graphical information
- obtained more information from graphs

- had greater overall achievement on graphing items
- were better at “symbolizing”, that is, finding an algebraic representation for a graph
- better understood global features of functions
- better understood connections among graphical, numerical, and algebraic representations.
- had more flexible approaches to problem solving
- were more willing to engage in problem solving and stayed with it longer
- solved nonroutine problems inaccessible by algebraic techniques
- believed calculators improved their ability to solve problems.

While many researchers have found that students’ positive attitudes toward technology, and especially graphing calculators, often correspond to an increase in student understanding, others have reported a positive student attitude can often hide a serious lack of student understanding. Schoenfeld (1989) reported results from a year-long study of detailed observations, analysis of videotaped instruction, and follow-up questionnaire data from sixty students in two high school geometry classes . He found that despite the fact that student attitudes toward their graphing calculators were quite positive, students nevertheless viewed mathematics simply as memorization, answer getting, an uninteresting set of rules, and something that need not be retained after the exam. Nachmias and Linn (1987) observed students during a physics experiment in which students studied the graphs of natural phenomena such as cooling liquids. As the experiment unfolded, a graph of time versus temperature was displayed on a view

screen for the students to observe. Despite positive student attitude towards the graphical environment being used, students nevertheless displayed poor understandings of the phenomena being studied. Tall (1989) observed, interviewed and surveyed several classes of high school students concerning their usage of graphing calculators. He reported that students who viewed graphing calculators positively may still reveal serious misconceptions of topics they purport to have mastered. For example, he found that students often cite belief in “the authority of the computer,” even as they misinterpreted the results the graphical technology provided. He claimed that the technology may actually contribute to students having an over-inflated view of their mathematical aptitude, because their positive attitudes about the technology often prevent them from recognizing that they are not mastering the material. After three years of using graphic calculators in the teaching of introductory calculus, Jones (1993) claimed that, while students generally enjoyed using them and had a positive view of them, there had been no great change in mathematical understanding. He stated that “there is a need to go beyond the immediate issues of curriculum and classroom practice, and focus on the fundamental issue of the nature of the user’s interaction with the technology” (p. 212).

Potential Difficulties

While many researchers report positive effects of graphical calculators on both students and instructors, occasionally researchers find a neutral or negative overall effect. For example, Graham (1998) studied the achievement of fifty college freshmen enrolled in two precalculus classes, equally split between the experimental and control groups. The students in the experimental group who used graphing calculators and the control group who did not were assigned to their respective classes by normal registration procedures, and both classes were taught by the same instructor. No significant differences in achievement between the experimental group and the control group were found using the same examination instruments. Shoaf-Grubbs (1992) studied two hundred students in six pre-calculus college classes in which three used graphing calculators and three did not. No difference was found on achievement tests between the experimental and control groups. Other studies have had similar results; that is, that there were no significant differences in achievement between the experimental group using graphing calculators and the control group (Army, 1992; Emese, 1993; Hall, 1993; Norris, 1995; Penkow, 1995; Rich 1991; Shoaf-Grubbs, 1992; Thomasson, 1993). In some instances, results have even shown graphing calculator use to have a negative impact on achievement, in that the control groups had significantly higher scores in identical tests of achievement than the experimental group (Giamati, 1991; Upshaw, 1994).

Ponte and Canavarro (1993) found that student interactions with and uses of graphing calculators may be underreported in cases where students have never used them before. They found that in such cases, even if researchers saw positive effects of the calculators, students tended to attribute any success more to their teacher's style and personality than to the use of this technology, thus creating the possibility that such positive uses would not be noted and reinforced. Other difficulties have been documented as well. The visual representations made possible by graphing calculators can lead to misconceptions, such as the "graph as picture" interpretation (Goldenberg, 1988; Mokros and Tinker, 1987). In these cases, students employing graphing calculators sometimes begin to think of a function as a picture on the screen (or paper) rather than a relationship between variables. Some students may treat a graph as just another representation to remember rather than as a more central part of their function concept image (Slavit, 1993). For instance, students may mistakenly come to think of a function as three (or more) separate things; an algebraic rule, a picture on a piece of paper, and a squiggle on the screen of their calculator. Williams (1993), using observations and interviews of Pre-Calculus students, discovered student errors related to graphing technology, such as struggling with the viewing window and recognizing discontinuities. Simon (1999), in interviews with community college students, found that some students develop the counterproductive attitude that math can't be done without a calculator.

Still other problems have been recognized. Students with little training in the use of the calculator may have difficulty adjusting to the instruction and may not benefit (Giamati, 1991). Also, some instructors with a poor technology background and/or strong feelings about newer technologies may have difficulty adjusting to the calculators, and their struggles may negatively impact student performance (Bond, 1988). It is not uncommon for researchers to report that, in their opinion, teachers who at first began to make a positive use of graphing calculators in their classrooms sometimes revert to their previous teaching style. Simmt (1997) observed and interviewed six algebra teachers in their classrooms and reported that the teachers, although enthusiastically utilizing the calculators during the first few weeks of the school year, gradually eliminated or curtailed their use as the school year went by. Although the teachers on the whole believed the calculators had good potential to improve their instruction, most eventually decided that the calculators did not fit into their philosophy of mathematics education. They noted that they had spent many years honing a teaching style, and eventually felt uncomfortable when realizing that the calculator was beginning to change it. Ward (1998) warned that a failure on the part of the teacher to point out to students shortcomings of graphing calculator technology, as well as the potential for misconceptions, could lead teachers to think that their students are using graphing calculators as analysis tools that encourage exploration and

investigation, when in reality the students may be learning little, and may harbor serious misunderstandings.

There is also the possibility that students will come to view the graphing calculator as incapable of making mistakes and overly trust the answers or visual displays that it generates. Reys, Bestgen, Rybolt & Wyatt (1980) gave a 7-question exercise to more than one hundred students using a calculator programmed to deliberately provide wrong answers. Thirty-six percent of students went through the exercise without verbalizing any concern about the accuracy of the calculator. Nachmias and Linn (1987) reported student participation in a physics experiment in which students used a graphing device similar to a graphing calculator to graph a liquid's temperature over time. Students were expected by the instructor to interpret the jagged looking graph as really being a smooth curve, but misinterpreted the graph. Other similar misinterpretations moved the researchers to comment that students may come to view the computer as the ultimate authority in the problem solving process. Lapp (1997), citing similar misinterpretations, claims that the graphing calculator may cause some students to lose some autonomy in the problem solving process, and turn over too much of the "power" to the calculator.

Because of these issues, many are calling for additional research. As an example, after writing positively about graphing calculators and their uses, Dunham and Dick (1994) note the following questions exemplifying possible research studies:

- Which aspects of graphing calculators bring about improved understanding?
- What role do multiple representations play in learning with graphing calculators?
- What paper-and-pencil skills will retain their importance?
- Can technology use sometimes impede understanding? Under which circumstances?
- Does it take a while to learn a graphical way of thinking before benefits emerge?
- As graphing technology gets easier to use, will we see more positive effects of its use?
- Does graphing technology promote any new errors or misconceptions?
- What accounts for the difference between success and failure in implementing the use of graphing calculators?

Conclusion

Researchers have been strongly encouraging teachers, particularly at the high school and undergraduate level, to consider using this new generation of powerful and highly sophisticated graphing calculators in their classrooms, both as an instructional aid and as a problem solving tool for students. Teachers at all levels of schooling have been encouraged to think more about when and how to integrate graphing calculators into their classrooms and individual lessons. Yet at the same time, teachers have the responsibility to be skeptical of the calculator, and to monitor closely student use, not

assuming that the mere presence of a graphing calculator will necessarily prove to be positive. And teachers are encouraged to seek out new research on these tools.

Chapter III

Methodology

To judge the validity of student perceptions of the usefulness of their graphing calculators, this study utilized a qualitative methodology. The subjects of the study were students in three undergraduate Pre-Calculus classes during the Fall Semester of the 2003-2004 school year. There was a total of two instructors for the three classes; each class had a maximum enrollment of thirty-five students, and all the classes were full. (Of the 105 students, eleven dropped within the first week and were replaced by eight students who were on a waiting list.) Graphing calculators were required for enrollment in each course, and students were to have one of the following calculators: TI-83, TI-85, TI-86 or TI-89. Any of these four calculators were judged by the instructors to be adequate for the class. Each instructor agreeing to participate in the study offered some basic calculator training for the students at the beginning of the course. Both instructors were quite familiar with the graphing calculators used in the classes and had been using graphing calculators in their classrooms for more than five years.

During the first week of class, I introduced myself and gave a ten minute presentation about the research project, and gave each student contact information if they wished to participate. (The instructor gave me the email addresses of those who came to the class from the waiting list, and I contacted them by email.) Students who

contacted me to volunteer for the project met with me in person and were given a consent form to return to me if they wished to proceed. As a part of the consent form, I asked students for permission (1) to contact them, either in person, on the phone, or via email, during the semester for questions about what may or may not have happened during recent classes, problems that came up on homework assignments and/or quizzes and exams, and (2) to possibly select them for more detailed interviews. I deliberately chose to hide the specific topic of my research from the students. I also chose to hide this from the instructors. I simply informed the instructors that I was studying student problem solving behavior. I felt that this would prevent students (and instructors) from confounding the data by using the calculator just to please me, or to “help me.” I wanted to see genuine use of the calculators in the context of a “normal” semester without any prodding from me.

There were three ways in which the students were observed and/or contacted. First, I was present during each class period as an observer (with a few exceptions in two of the classes). Second, I observed students when they were assigned to work together in lab sessions (held once a week) led by a tutor assigned by the Math department. Third, I asked the students to participate voluntarily in one-on-one problem solving and interview sessions with me outside of class. For the one-on-one sessions, the Mathematics department arranged for me to have the use of a vacant faculty office. Seventy of the students in the three classes volunteered to participate in research project.

Data Collection

In both the regular lecture periods and the lab sessions, I was particularly interested in observing the following:

- 1) The teacher's use of the graphing calculator during classroom demonstration and/or lectures and whether students were actively engaged with the teacher in such situations.
- 2) Student use of the graphing calculators
- 3) Whether or not students (or lab assistants) used their graphing calculators during their lab sessions
- 4) The extent to which students used their calculators during tests.
- 5) Problems (topics) in which students relied heavily on their graphing calculators
- 6) Whether or not there was any evidence that the graphing calculators were helping students progress in understanding certain topics

To help me isolate student perceptions of the usefulness of their calculators, each instructor agreed to place certain problems of my creation on homework, quizzes and exams. Problems were divided into four common categories of Pre-Calculus Mathematics: linear functions, quadratic functions, exponential functions, and systems of equations. The problems and categories are listed in Appendix B. The instructors agreed to afford me access to the homework assignments, quizzes and exams, so that I

knew when a problem of my design was assigned or used as an assessment. Shortly after students were exposed to the problems (either in class, on a homework assignment, or on a quiz or exam,) I asked students to discuss their solutions to these particular problems in a one-on-one interview session. I contacted them either in person, via email, or by phone. The interview sessions lasted between fifteen and thirty minutes. All one-on-one interviews were audiotaped. (Note: In these interview sessions, I also used problems other than those that I had created. For example, I used a few problems from the text given by the instructor as homework, as well as several of the questions from the quizzes and exams.)

Interview Methodology

The one-on-one interviews were held in a spacious office which was assigned part-time to two Emeritus faculty members. They were notified when the interviews would potentially be held so that there were no embarrassing interruptions. During these interviews with the students, soda, juice, and candy such as Skittle and M&M's were provided to help create a relaxed, non-threatening environment. As students worked on the problems, or discussed their solutions, they were encouraged to "think aloud" and to share their thoughts as freely as they wished, to illuminate as much student thinking as possible for the researcher (Ericcson and Simon, 1993).

After two weeks, eight students dropped out of the study, most citing time difficulties. Sixty-two students remained actively involved. During the third week of class, and extending into the fifth week, I began to ask students if they were willing to be “supersubjects” of the study, and agree to meet more regularly for more detailed study. I selected them based on the following criteria:

- Those who used the calculator “frequently” enough so I had something to observe. “Frequently” can be defined here as knowing enough about the capabilities of the calculator to be able to decide (or explain) why or why not the student chose to use it. If they choose to use it for a problem, there will clearly be something to observe. If they choose not to use it, and can explain why they chose not to use it, that also is useful data.
- Those willing to discuss their problem solving techniques with me during our one-on-one sessions, and especially their use or non-use of their calculator.
- Those able to reach definite conclusion to problems (regardless of whether they are right or wrong) so that I could make a judgment about whether or not they understood the topic or concept, and the extent to which the calculator helped or did not help them reach their conclusion.
- Those who developed a definite opinion about their calculators, and a willingness to share their opinion with me during our time together. This

included several “non-verbal” clues that led me to believe that they either were happy or unhappy with the help that their calculator was providing. Several perceptions of the calculator came in the form of puzzled looks, smiles of satisfaction, and other such clues.

Of the approximately twenty-five students asked to participate in more detailed interviews, twenty agreed. Two later dropped out and requested that the data from their interviews not be used, reducing the number of supersubjects to eighteen. The researcher has no reason to believe that the data from these two students would have significantly altered the outcome of the results, nor the conclusions drawn. The interviews with the supersubjects also were audiotaped. I met with these supersubjects at least once a week for the remaining ten to twelve weeks of the semester. Some subjects were seen as often as twice weekly. Students not asked to be “supersubjects” were still contacted. This was done in case I chose later to invite some of these students to become supersubjects, which did happen in one case. (This is the fascinating case of Quentin, who I discovered using paper mathematical tables, which he carried with him. Appendix G gives more details of Quentin and his story. This increased the number of supersubjects to nineteen.) The data pertaining to these nineteen supersubjects comprised the data set which I analyzed and interpreted to answer the questions posed in this study. The final set of supersubjects included nine men and ten women.

As mentioned earlier, the Mathematics Department offered me the use of an emeritus faculty office to use as a meeting place with students during the entire semester. The office was available from early in the morning until late at night, and so I was able to accommodate the inevitable requests that came from students to meet at odd hours and on short notice. The office was well lit, well ventilated, and had enough room so that students, when working on problems or discussing their thinking, were not crowded by either the environment or the researcher. During the in-person interviews, the students were provided with soda, juice, and several kinds of gum and candy for any who wanted it, in an effort to make them comfortable and hopefully to prolong the interview length.

In making observations about how students were using (or not using) their calculators to solve problems, my primary analysis focused on how the calculator was employed and the student's own recollection of calculator use. This was done by comparing my class notes and lab session notes with the student interviews that I conducted. I compared *my* perception of whether or not the calculator helped a student to learn a concept with the student's perception. A particularly good time to collect data was shortly after an exam or a particularly heavy classroom use of the calculator when the use/non-use of the calculators was still fresh in the students' minds.

There were several interesting calculator “events” during the course of each class, and several during the lab sessions. Some of these difficulties proved to be the result of calculator input errors. Sometimes, the calculator displayed a graph unexpected by either the students, the instructor, or the lab assistant, and often caused considerable discussion. Other times, with the help of the calculator, answers were found which caused disagreement, or even conflicted with the answer in the back of the book. Occasionally, a problem arose with a calculator that was not remedied in the current class period. When these “events” happened, I tried to reach the student(s) involved as soon as possible to facilitate recall. Many of these events were discussed in the one-on-one interviews, and provided some good problem solving material.

Being asked to solve mathematics problems in front of others can be a nerve-racking experience, even for excellent and confident students. In an effort to alleviate this tension and build rapport with the students, the first (and sometimes second) interview with each student was deliberately low-key. Because the interviews often brought about situations in which the students were confused and uncomfortable with a challenging problem, during the first and/or second interview I made every effort to pose mathematics problems to the student which I believed he or she had the ability to solve. I wanted to give each student the feeling that success, and not just failure, was to be part of our time together.

There was another very important reason for posing “easy” problems to each student at our first face-to-face meeting. I asked students to explain their thinking about how they solved each problem, *whether or not I believed they were right*. It is well known that mathematics students often feel that if they are questioned about their answers or their reasoning, they must be wrong. I wanted to get them used to the idea that I was going to ask them to explain their thinking, regardless of whether I believed that their answer was right or wrong. In other words, I wanted to immediately cultivate an atmosphere in which students were willing to be as honest as possible with me (Patton, 1980). I believed that inviting them to talk about their answers and explain their reasoning on problems when they are sure that they are right helped them to develop at least a measure of willingness to discuss their answers to future problems. In this way, I hoped to gain their confidence, and to prepare them to expect regular questioning, without having them believe that I was challenging them because I believed they were wrong.

Each “supersubject” participated in a 30-minute exit interview near the end of the semester, which was also audiotaped. In the exit interview, I asked them to complete a survey concerning whether or not they felt the calculator helped them learn the four topics in question. I also asked them about their mathematical background and their experience in using graphing calculators, if this information had not already come up previously. The questions pertaining to calculators in the exit survey can be seen in

Appendix C. Also, in the exit interview, I reserved certain problems to which the students had not been exposed. These problems are listed in Appendix D. The exit interview also served as an avenue for me to ask lingering questions that I had not as yet had a chance to pose. I kept a record of these potential exit interview questions/observations for each student.

My data consist of my interaction with the nineteen “supersubjects.” To protect their identity, each supersubject was assigned a pseudonym for reporting purposes. Data included observations in the classroom, in lab sessions, personal and email contacts, one-on-one interviews and problem solving sessions, and ongoing comparisons between what students were perceiving to be the benefits of the graphing calculators in helping them solve problems, and what I was observing. Data were also supplied from the exit interview of each “supersubject.”

To compensate students for their time, each was offered one hour of free tutoring prior to the final exam in exchange for participating. Students who agreed to become “supersubjects” were offered an additional hour of tutoring prior to the final exam. I did not schedule the tutoring for a student until the data collection for that student was complete. The tutoring sessions proved to be an excellent way to clear up many of the misconceptions that some of the students had, or to help them complete problems that they were unable to do in our one-on-one interview sessions. During the course of our

interviews, many times I neglected to point out errors that the students had made, because of my efforts to judge the degree and extent of their understanding. This was also done in an effort to see if their calculators could help them overcome the difficulty. To the extent possible, I kept track of these errors and strove to clear these up for the students during the tutoring sessions. Some students did not want the tutoring, so instead of the tutoring were offered a gift certificate for a meal at one of several local restaurants commonly frequented by university students.

Conclusion

Students were observed in class, in lab sessions, and in one-on-one interview sessions. The instructors also offered copies of exams and quizzes to the researcher after these assessments were used in class. Mathematics problems from these assessments were often used for discussion in the one-on-one interview sessions. Since the researcher did not wish the students to discern the primary focus of the study, questions posed to the students about the usefulness of their calculators were carefully mixed in with other questions throughout the interviews sessions, such as questions regarding their instructor, their textbook, their mathematical background, their lab sessions and their lab assistants, and classroom assessments. Every effort was made to create a comfortable and non-threatening environment in which to interact with the subjects, so that the data they provided would be as authentic as possible. Misunderstandings,

misconceptions and errors on the part of the students which the researcher decided not to correct during data collection were recorded and, as much as possible, discussed during the exit interview.

Chapter IV

Results

This chapter is devoted to addressing the first four research questions posed in Chapter I. These four questions will be discussed in turn in this chapter. The fifth research question is addressed in Chapter V. Again, the four research questions were:

- 1) What fraction of students had **valid** perceptions about the effectiveness of their calculator in helping them understand class topics? Do they have anything in common that would help researchers/teachers be aware that their perceptions are valid?
- 2) Are there students who felt the calculator helped them to understand class topics but in reality:
 - a) they did not understand the topic as clearly as they claimed?
 - b) they came to an understanding of the topic, but the calculator was of little use to them in doing so?
- 3) Might a student maintain the calculator was **not** useful in learning a certain topic but in reality:
 - a) the student was actually observed using the calculator in substantive ways, but may have dismissed such uses or forgotten them?
 - b) the calculator may have been used by the **instructor** in ways that facilitated student learning, but such usage was not reported by the student?
- 4) Do the students referred to in questions 2 and 3 have anything in common that would help researchers (and teachers) be aware that some student perceptions may be suspect?

Before Research Question 1 is discussed, it should first be noted that several students fit into more than one category. A student reported by the investigator to have a misunderstanding about whether the calculator helped him/her to understand a certain topic may not have had the same impression about whether or not the calculator helped him/her to understand another topic. Several students who misunderstood the role of the calculator in one or more topics had a good perception of the usefulness of their calculator on other topics. This reality conflicts with a common notion that sees the graphing calculator as either wholly helpful or wholly harmful to a particular student. This is discussed in greater depth in Chapter V.

Secondly, it turned out that one student named Quentin did not fit into any category. He provided little or no data that pertained to the research questions, because during the one-on-one interviews, as well as the exit interview, he offered very little feedback when asked about his calculator. During the first few weeks of class, he used his calculator sporadically, but as the semester went on, he used it less and less, and eventually did not use it at all. He did not bring it to class, lab sessions, use it on exams, and did not use it in our one-on-one interview sessions. When he needed information that most students normally obtain from a scientific or graphing calculator, he made use of paper logarithm tables and trigonometric tables that he kept with him, or drew graphs by hand. Part of this researcher's fascination with Quentin was not only that he proved

to be an outstanding student, but he was unusually skeptical and critical of technology such as his graphing calculator. His story appears in Appendix G.

Research Question 1) What fraction of students had valid perceptions about the effectiveness of their calculator in helping them understand class topics? Do they have anything in common that would help researchers/teachers be aware that their perceptions are valid?

In the opinion of this researcher, only three of the nineteen students (about 16%) seemed to have valid perceptions about their calculator a large majority of the time. The first was Steve. He developed a good grasp of lines and linear relationships, and his work distinctly showed that. He also clearly understood the ways in which the calculator helped him and was quite perceptive in recognizing cases in which the calculator either didn't help or when its use was neutral. He benefited from the instructor's use of the calculator and was able to recall specifics of these situations. He followed along when others used their calculators in lab sessions, and he learned (and retained) several useful techniques from doing so.

When it came to quadratic functions and quadratic equations, his ability to understand the effectiveness of his calculator was particularly impressive. He was able to recognize when it was helping, and also when it wasn't helping. In the following problem, reproduced below in Figure 1, Steve was asked to figure out which value of b would make the quadratic equation have only one solution.

- 1) Consider the quadratic equation $x^2 + 10 = bx$. For what value(s) of b does the equation have only one solution?

$$\begin{array}{l}
 b = \frac{x^2 + 10}{x} \\
 x^2 - bx + 10 = 0 \\
 b = 1 \\
 x = \frac{b \pm \sqrt{b^2 - 40}}{2} \\
 b^2 \leq 40 \\
 b = 2, 2 \\
 b^2 = 4ac \\
 -40 \\
 \text{all real numbers} \\
 \text{where } b^2 \leq 40
 \end{array}$$

Figure 1: Steve's paper work

After some thought, in which he performed a bit of algebra, he used the calculator to try various values of b , graphing the resulting quadratics on his calculator. He correctly convinced himself by this demonstration that, depending on the value of b , the equation could have both 2 solutions, 0 solutions, and one solution if he could find the right value of b . A bit more algebra and he decided that any b less than $\sqrt{40}$ would lead to only one solution. He realized that this was incorrect when he picked several examples of b which were less than $\sqrt{40}$ such as 4 or 5, which lead to two solutions, and not one solution as the problem requires. This moved him to return to the problem, where he finally found the right answer, b can equal $+\sqrt{40}$ or $-\sqrt{40}$. He then verified this on his calculator by graphing the function with both values of b . Below in Figure 2

is a likeness of what his calculator showed him to verify that the two graphs had only one solution.

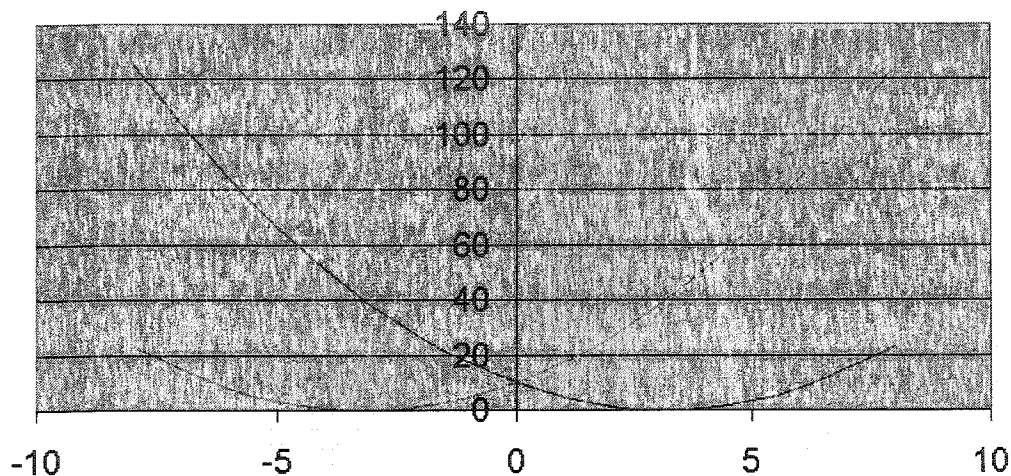

Figure 2: Steve's calculator work on the above problem

During the discussion of this problem, both as it happened, and when we reviewed it later, he was able to correctly identify precisely when the calculator was helping and when it was not.

In the next example, Steve was trying to find a parabola that passed through two given points. He first drew a coordinate system, and began to reason about how many parabolas could go through that point. He then used the calculator to draw some parabolas, hoping to chance upon the right answer. After realizing that this was unlikely

to succeed, he began to reason on the two variables that he was changing, b and c .

Figure 3 below shows his paper work:

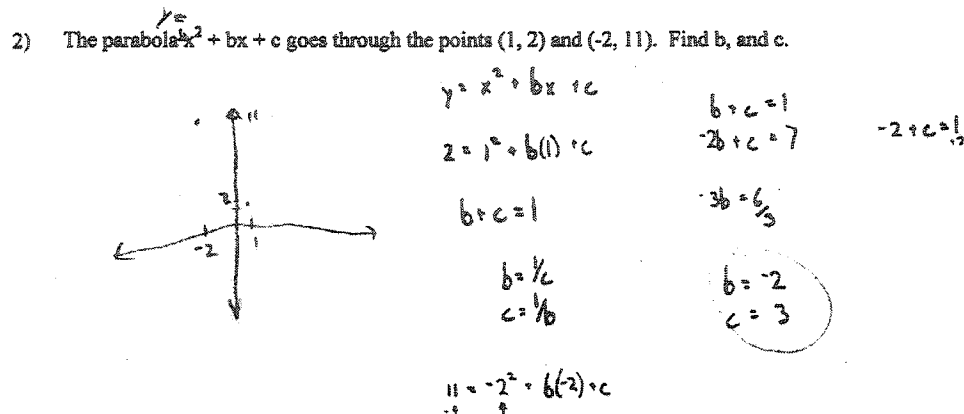

Figure 3: Steve's work on another problem

He then realized that because the problem had two unknowns, a system of equations might be a helpful approach to the problem. After some thought, he came up with the idea of replacing the x and y in the equation with the two points, leading to a system of equations. After solving for b and c , he graphed the parabola to verify his answer. During the process, and in subsequent conversations, he was correct in recognizing when the calculator was helping him, and when it was not.

In the next example, he didn't recognize that a similar approach to the last example would prove helpful, since there are two unknowns, the length and the width.

He tried experimenting with his calculator with different widths and lengths, but he eventually recognized that to get a good approximation would take much too long on the calculator, and that he needed another approach. Figure 4 shown below shows the problem as he started it:

- 2) The perimeter of a rectangle is 20 inches. If its diagonal is 8 inches, find the dimensions of the rectangle. An exact answer is preferred, but if you give a decimal approximation, give your answer to the nearest thousandth of an inch (three decimal places).

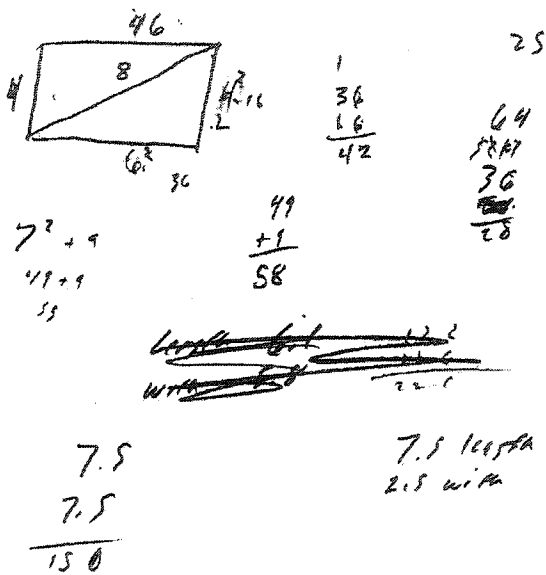

Figure 4: Steve and the Rectangle Problem

Once I pointed out the possibility of using a systems approach, he quickly got the solution. But he correctly realized (and admitted) that he was still making the concept his own.

In the final example from Steve's work, he is trying to find a quadratic equation with the two solutions $-\frac{2}{3}$ and $\frac{4}{5}$. He made an algebra error that led to a wrong quadratic function. Instead of $y = x^2 - \frac{2}{15}x - \frac{8}{15}$, he incorrectly found the quadratic function to be $y = x^2 + \frac{22}{15}x - \frac{8}{15}$. When graphing his function, he discovered that he had made an error but could not find the error. He recognized that the graph did not cross the x-axis at $-\frac{2}{3}$ and $\frac{4}{5}$, as should have been the case if he had found the right quadratic function. Figure 5 below shows a likeness of the graph that he created on his calculator:

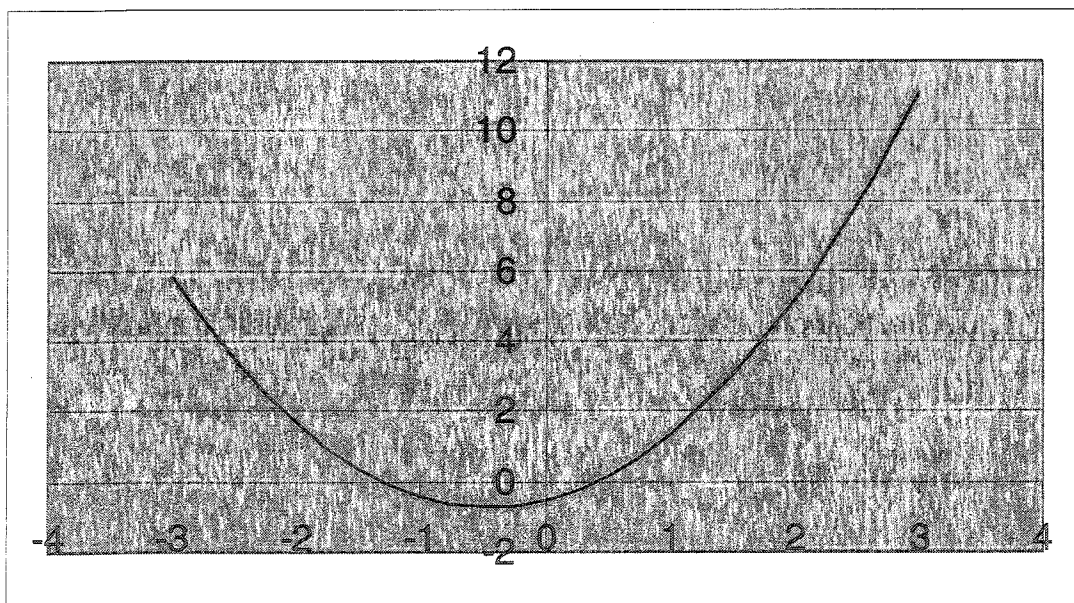

Figure 5: Steve's calculator image on a quadratic equation

He was correctly expecting that the graph would cross the x-axis at $-\frac{2}{3}$ and $\frac{4}{5}$.

But he noticed that the graph displayed on his graphing calculator did not do so. He became confused and thought (incorrectly) that perhaps the graph crossed the x-axis at $+\frac{2}{3}$ and $-\frac{4}{5}$ instead $-\frac{2}{3}$ and $\frac{4}{5}$. But that did not match his graph either. He did not at first find his error (I pointed it out later, and we talked it over), but he recognized that the calculator helped him discover that he had made an error. This led to a discussion of what the error was, and later helped us together find and correct it. He recognized that he may not have found the error without the help of the calculator. Figure 6 shows his paper work:

- 1) Write a quadratic equation having the solutions $-\frac{2}{3}$ and $\frac{4}{5}$.

$$\begin{array}{r} -\frac{2}{3} \quad + \quad \frac{4}{5} \\ \hline -\frac{8}{15} \end{array}$$

$$\begin{array}{r} \frac{16}{20} \\ -\frac{4}{5} \cdot \frac{8}{10} \end{array}$$

$$ax^2 + bx + c = 0$$

$$(x + \frac{2}{3})(x + \frac{4}{5})$$

$$x^2 + \frac{14}{15}x + \frac{8}{15}$$

$$x^2 + \frac{22}{15}x + \frac{8}{15} = 0$$

$$\frac{4}{7} \cdot \frac{2}{3} = \frac{8}{21}$$

$$\frac{10}{11} + \frac{12}{11} = \frac{22}{11} = 2$$

$$\frac{22}{15}$$

Figure 6: Steve's paper work on the above quadratic equation

The key to Steve's success in gauging the effectiveness of his calculator use was not only to know when it was helping him, but to recognize when it wasn't. He seemed in several situations to know in advance that the calculator was unlikely to help. Among the nineteen subjects, this was a rare combination.

Kyle was the second student whose opinions about his calculator use concurred with my observations the vast majority of the time. He attended the calculator training at the beginning of the semester and followed along whenever the instructor or the lab assistant made calculator demonstrations during the semester. During our one-on-one sessions, he often spoke about these demonstrations, and insisted that on some occasions the demonstrations helped him, while on others they did not. When he used the calculator in these one-on-one sessions, he was consistently correct when assessing whether or not the calculator was helping. Here is a typical example of how he used the calculator, and how he was able to make sense of why or why not it was helping. In this example of solving a radical equation, he made an algebra error, which led to an incorrect answer, $x = 6$. Figure 7 below shows his work.

The sum of the square roots of two numbers is $\sqrt{30}$. One of the numbers is 4 times the other. Find the numbers.

$$\sqrt{x} + \sqrt{4x} = \sqrt{30}$$

$$(\sqrt{x})^2 + (2\sqrt{x})^2 = (\sqrt{30})^2$$

$$x + 4x = 30$$

$$5x = 30$$

$$x = 6$$

Figure 7: Kyle's work on the square root equation

When he checked the answer by hand, he wasn't sure if he had the right answer or not. He initially thought that $\sqrt{6} + \sqrt{24}$ might have been equal to $\sqrt{30}$, but rather than calculate the individual square roots by hand, he chose to graph both sides of the equation to see if the two graphs intersected when $x = 6$. When they did not, he was stuck for the moment, unsure of where the error was. He acknowledged that although the calculator had helped him detect an error, he was frustrated that he so far was unable to use it to find the error. I suggested that since he suspected an algebra error, he should

start on the very first line. Was there any way the calculator could help decide if his first line was correct? He spent about three minutes thinking, and I spent this time in silence, occasionally asking him to think out loud. Eventually, he came up with a very imaginative solution. He graphed the left side of the original equation (I reminded him he had to square it), and compared it to the left side of his first step (which he thought he had squared correctly)

He was startled to see that they were indeed different! Now he was very confused, but conceded that he had really gotten somewhere, because he now knew exactly where the error was (if indeed it was the only one). He then decided to pursue the alternative algebraic of adding \sqrt{x} to $2\sqrt{x}$ to get $3\sqrt{x}$. This proved successful, and he got the correct answer, which he then verified with the calculator. Afterward, I showed him the problem with his squaring idea.

Kyle's behavior with his calculator in this example was similar while working other problems. He seemed to be quite capable of identifying both when the calculator was going to help, and when it was not. On some occasions he chose not to use the calculator because he felt that he could solve the problem without its use. On other occasions, he used his calculator to corroborate answers. A fascinating example of this was when he used the calculator to check the three real roots of the following equation:

$6x^3 - 5x^2 - 16x + 15 = 0$. He correctly identified the solutions as 1 , $\frac{3}{2}$, and $-\frac{5}{3}$. He at

first thought these answers were wrong, arguing that since the polynomial $6x^3 - 5x^2 - 16x + 15$ had integer coefficients, the solutions must therefore also be integers. He asked me if that was true, and I replied by asking if there was any way to check his answer. After a minute or two of puzzled silence, he recalled that he could graph the polynomial and see where it crossed the x-axis. Below in Figure 8 is approximately what he saw when he first used his calculator to graph $6x^3 - 5x^2 - 16x + 15$.

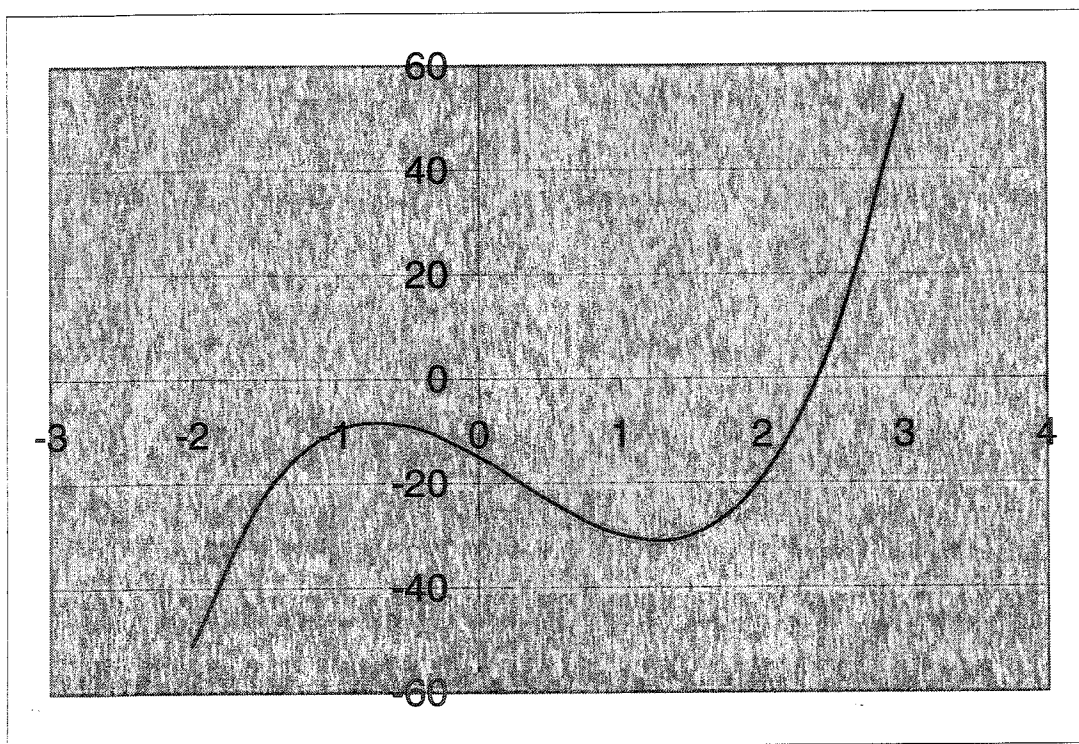

Figure 8: Kyle's first calculator image on the cubic equation problem

This was of course the incorrect graph. What he didn't at first realize was that he had made an input error. He had input the function $y = 6x^3 - 5x^2 - 16x - 15$ instead of

$y = 6x^3 - 5x^2 - 16x + 15$. Now he was even more confused, because he was expecting that he might see three integer solutions, and now he saw only one solution which was not even an integer. He asked for my intervention, but I decided to say nothing, other than asking him to “think out loud” as he struggled with the problem. He talked about one solution, three solutions, and seemed to be genuinely confused. Eventually he decided to check one of his original solutions, the number 1. When he discovered that it was a solution, his confusion became extreme. After a great deal of additional thought, he finally realized that he may have made a calculator error, and he found his error. Instead of $y = 6x^3 - 5x^2 - 16x - 15$, he correctly graphed $y = 6x^3 - 5x^2 - 16x + 15$, and saw the following graph, shown in Figure 9.

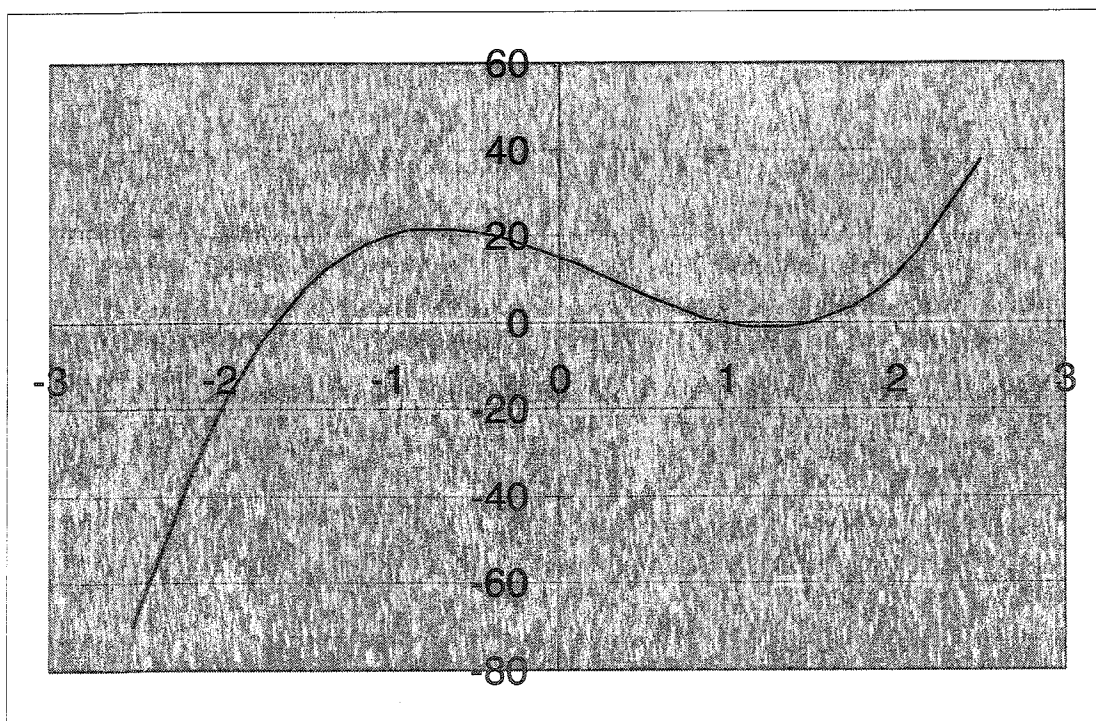

Figure 9: Kyle's second calculator image on the cubic equation problem

Now he clearly saw the three solutions that he had originally calculated, as the graph crossed the x-axis at the values 1 , $\frac{3}{2}$, and $-\frac{5}{3}$. He was relieved.

Not only did Kyle use the calculator in ways which were helpful to him, he reported as such. During our exit interview, he clearly remembered the above two examples, as well as other instances where the calculator was helpful. He also was quick to point out the situations in which the calculator may have hindered him, such as the situation just noted in which an input error made for some confusion. Overall, his perceptions of how the calculator helped him or sometimes confused him closely mirrored actual happenings.

Brad was the third student whose assessment of his calculator usage agreed with the way I saw it, although only in a trivial way. As the semester wore on, he used his calculator less and less, and would often lament he wasn't getting much out of the class. He didn't learn much and his calculator was of limited help in learning what little he did, but he recognized this and agreed with my assessment that the calculator didn't help him much.

What did these students have in common? Recall that Brad's perceptions were valid in only a trivial way, because he admitted that he learned little from the class and admitted that the calculator was of little use to him, conclusions with which the

researcher concurred. The other two students, Steve and Kyle, did indeed have some things in common. Both were talkative, were willing to communicate their ideas, and were willing to concede occasional confusion. They had very good self-monitoring skills, meaning that they were likely to seek corroboration for their solutions, and seemed to be aware when they had wrong answers or were on the wrong track. Both were persistent in attempting to find errors and fixing them. Also of importance was that when they recognized that they had made an error, they reacted for the most part calmly while clearing up the confusion. An interesting pattern also developed with their use of the calculator. They would often talk about whether or not the calculator might prove useful in solving the problem, even before they even touched the calculator. And when they did reach for their calculator, they were almost always very good at describing precisely how they were going to use it.

Research Question 2a) Are there students who feel the calculator is helping them to understand class topics but in reality they do not understand the topic as clearly as they claim?

Twelve of the nineteen subjects made a claim that the calculator substantially helped them on at least one of the four topics, but evidence existed that their understanding of that particular topic was incomplete or even poor. The following fifteen examples come from these twelve subjects who, although claiming the calculator helped them to understand certain topics, nevertheless provided evidence that their

understanding was less complete than they believed. They claimed that their calculators gave them a greater understanding than they actually possessed.

Examples of student behaviors and/or errors which the researcher will cite as evidence that the student has an incomplete understanding of a topic will include but will not be limited to:

- A misunderstanding of the Cartesian coordinate system, such as where negative and positive numbers lie on the coordinate plane, or the mistaken idea that only whole numbers are used to identify points on the plane.
- Misunderstanding the slope of a line, such as not recognizing slope as the rise divided by the run between two points, or not being able to calculate slope given two points.
- Understanding that $y = mx + b$ is not the only way to write the equation of a line.
- An inability to find the maximum and/or minimum point of a parabola.
- Being able to solve quadratic equations.
- Understanding that quadratic equations may have zero, one or two solutions.
- The recognition that a problem which can be solved with a system of equations may necessitate that the student will have to figure out the equations; in other words, the equations may not be explicitly provided for the student.
- The understanding that logs of negative numbers are not defined in the real number system.
- A misunderstanding / misapplication of the laws of logarithms.

Examples of student behaviors and/or errors which the researcher will cite as evidence that the student is overstating the usefulness of his or her calculator will include but will not be limited to:

- Making a claim that his or her calculator has aided in the understanding of a certain topic, when evidence exists that he or she does not understand the topic as well as claimed.
- Not recognizing that the calculator has provided an answer that is absurd or clearly not possible given the statement of the problem.
- Not recognizing a calculator procedure which would corroborate a correct answer or reveal an incorrect answer.
- Not using the calculator's graphing capability to corroborate an algebraic solution, or not using the calculator's graphing capability to find an estimate before attempting an algebraic solution.
- Misunderstanding and/or misinterpreting the output of the calculator.
- Forgetting a calculator procedure previously used, which might indicate that the student had simply memorized the procedure.
- Upon recognizing that an algebraic or calculation error has been made, not realizing that a calculator procedure known to them would help to find the error. An example of this would be recognizing that graphing both sides of an equation would help reveal algebraic manipulation errors, or corroborate correct manipulations, allowing them to eliminate enough possibilities to reveal the error.

Example # 1

The first example comes from an exit interview with Nancy. I asked her if she felt that she had learned a lot about lines. She replied yes. She felt very certain that she had a very good understanding of lines. She even said that she could answer a wide variety of questions concerning lines. Given her positive response, I asked her (among other things) if she thought that her calculator had helped as she learned about lines. She very enthusiastically said yes. She mentioned using the calculators in class, on her homework, and recalled the lab assistant and the instructor using the calculator for

demonstrations. She also said that the calculator helped her to complete exam questions that dealt with lines. It was clear that she gave the calculator a great deal of credit in her study of lines. Then, just a few minutes later, Figure 10 shows the following work:

This problem asks the student to find where a line intersects the x-axis.

- 1) Find where the tangent line crosses the x-axis. Hint: the line segment containing the radius and the tangent line meet at a 90° angle.

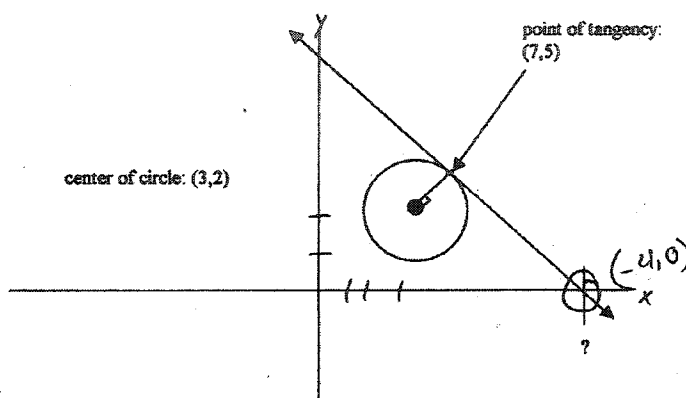

error

$$m = \frac{5-2}{7-3} = \frac{3}{4} = \left(-\frac{4}{3}\right)^{\text{perp.}}$$

~~$$y - 5 = -\frac{4}{3}(x - 7)$$~~

~~$$y - 5 = -\frac{4}{3}x + \frac{28}{3}$$~~

~~$$y = -\frac{4}{3}x + \frac{28}{3} + 5$$~~

~~$$0 = -\frac{4}{3}x + \frac{28}{3} + 5$$~~

~~$$-4 = x \quad (-4, 0)$$~~

Figure 10: Nancy's work on a linear equation

While working on the problem, she made an algebra manipulation error (pointed out with the arrow above) which led her to believe that the answer was that the line crossed the x-axis at an x-value of -4. The algebra error occurs in the third line of the above work, in which the $-\frac{35}{3}$ should be $+\frac{35}{3}$. Of course, the line crosses the x-axis at a positive value, and so -4 is the wrong answer. If she possessed as much knowledge of lines as she claimed, she would have realized that -4 could not be the answer, and may have been able to go back and find her error. Even after I implied that I wasn't sure about her answer, she maintained that her answer was correct and did not think it was necessary to review her work. This was not the only case in which Nancy displayed a poor understanding of the concept of lines and linear relationships; on several occasions, she had similar misunderstandings. On one of these occasions, she was unable to correctly find the slope of a line given two points. On another occasion, she believed that a horizontal line has an equation of $y = x$. She clearly had a poorer understanding of lines and of the coordinate system than she believed. Yet she claimed that the calculator helped give her a greater comprehension than she actually had.

(This might be a good time to note that, for each subject, a record was kept of misunderstandings and errors, with a view to helping students later. When data collection was complete for a particular student, as much of this saved material with them as time permitted was reviewed, either in the exit interview or a tutoring session.)

Example # 2

This example also is taken from an exit interview, in which Rita was very proud to have received, in her words, a “profound” understanding of lines. In our subsequent discussion, she was quite confident that the calculator had assisted her in the study of lines; she was sure that her understanding would be far less substantial without the use of it. In the following work (Figure 11), which she performed less than five minutes after claiming a profound understanding of lines, she made a similar error to Nancy.

- 3) Find where the tangent line crosses the x-axis. (Hint: the tangent line and the segment containing the center of the circle and the point of tangency meet at a 90° angle.)

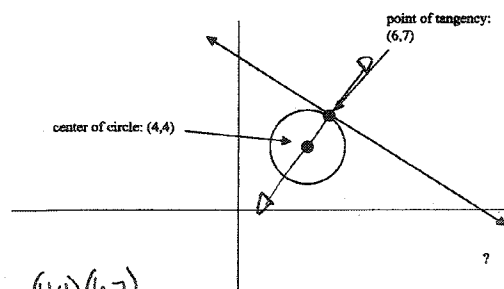

$$\begin{aligned}
 m &= \frac{(4,4)(6,7)}{7-4} \\
 &= \frac{4-4}{6-4} \\
 &= \frac{0}{2} = 0 \\
 3(y-7) &= -\frac{2}{3}(x-6) \\
 3y-21 &= -2x+12 \\
 3y &= -2x-9 \\
 y &= -\frac{2}{3}x-3 \\
 0 &= -\frac{2}{3}x-3 \\
 -\frac{3}{2} \cdot 3 &= -\frac{2}{3}x - \frac{9}{2} \\
 x &= \frac{-9}{2} - 4\frac{1}{2}
 \end{aligned}$$

error

Figure 11: Rita's work on a linear equation

Again, the x -value of the point of intersection is clearly positive, but yet she claimed it was $-4\frac{1}{2}$. Even my skepticism did not dissuade her from her belief that her answer was correct. “Numbers don’t lie,” she said proudly. (Like Nancy, Rita provided other examples of her lack of understanding of lines.) Despite her claim that she understood the concept of lines, clearly her understanding was limited. The key point here is not that she possessed such a limited understanding; the real issue is that she has such a limited understanding while claiming that her graphing calculator has helped her to gain an understanding that she does not possess.

Example # 3

Darla, working on the same problem as the two previous students, claimed that the calculator was “indispensable” in helping her grasp the concept of lines. She reported that the instructor’s use of the calculator helped her, as well as her own use of the calculator during lab sessions and when she worked on her homework. As she worked on the problem, she found the equation of the line correctly, but then said that she could not go any further. She demonstrated limited understanding of lines; clearly her understanding was incomplete. Figure 12 below shows her work:

Find where the tangent line crosses the x-axis. (Hint: the tangent line and the segment containing the center of the circle and the point of tangency meet at a 90° angle.)

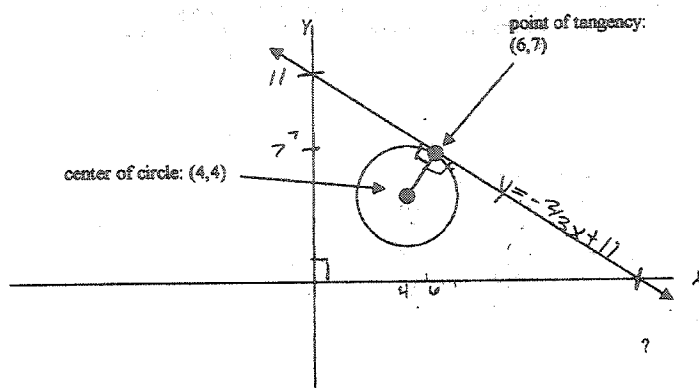

Handwritten work showing the derivation of the equation of the line:

$$y = x + b$$

$\frac{7-4}{6-4} = \frac{3}{2} = m$

$$y = \frac{3}{2}x + b$$

$$7 = -\frac{2}{3}(6) + b$$

$$7 = -4 + b$$

$$+4$$

$$\boxed{11 = b}$$

$$y = -\frac{2}{3}x + 11$$

equation of line

Other calculations shown:

$$\frac{7}{6} = \frac{11}{x}$$

$$7x = \frac{66}{7}$$

$$x = \frac{66}{7}$$

$$\frac{4}{4} = \frac{11}{x}$$

$$44 = 4x$$

$$\frac{44}{4} = 11 = x$$

Figure 12: Darla's work on a linear equation

After she successfully got the equation of the line, she did do some calculator work. She graphed the line and even discovered that it did indeed pass through (6,7). "Isn't that a neat way to use the calculator!" When I then asked her to continue with the problem, she responded that you couldn't find the place where it crossed the x-axis, because it wasn't b. (She explained b to be the variable b in the equation $y = mx + b$,

where b represents the y -value of the point where the line crosses the y -axis.) When I asked if the line crossed the x -axis, she said that it “probably did. But you can’t find it because it’s not b . It’s not part of the equation.” She did not seem to understand that she could find that intersection in various ways, even including the same way she found that it passed through $(6,7)$. Darla also provided other evidence that her knowledge of lines was inadequate. For example, she professed ignorance of the existence of any equation of a line other than $y = mx + b$. And this caused her difficulty when either m or b was not provided as she would have liked. She did have a limited comprehension of lines, perhaps a bit more than the previous two. But yet she did not possess as rich of an understanding as she claimed. The calculator may have been of limited use, but her estimation of the help her calculator provided seems to be overstated.

Example 4

During the exit interview, Greg indicated he was satisfied with his understanding of lines. In response to my question about whether the calculator had helped him in his understanding of lines, he answered in the affirmative. He mentioned the instructor’s use of the calculator, as well as the student who led the lab sessions. He also credited the calculator for helping him to complete the homework and correctly answer exam questions about lines. I had him work on a problem dealing with lines, and after he struggled a bit, we put the problem aside, and I drew the following diagram. The actual

work is too messy to reproduce, so I will provide some computer diagrams in Figure 13 which represent the drawings that I made.

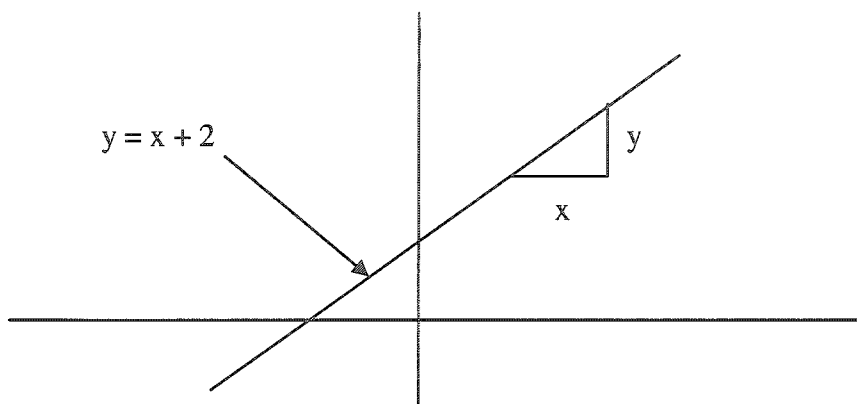

Figure 13: Greg's work on a slope problem

I asked Greg to tell me what y divided by x was. He said he had “no clue.” Of course, y divided by x is one, the slope of the line. I gave him a hint that it had to do with slope, but he still could not provide an answer. His only response was that he would like to use a system of equations to find the answer, since there were two variables. A few more minutes of conversation revealed that he had little real knowledge of lines. He had an apparent knowledge which led him to claim more knowledge than he actually had.

I then drew the following and asked him what the slope of the line was.

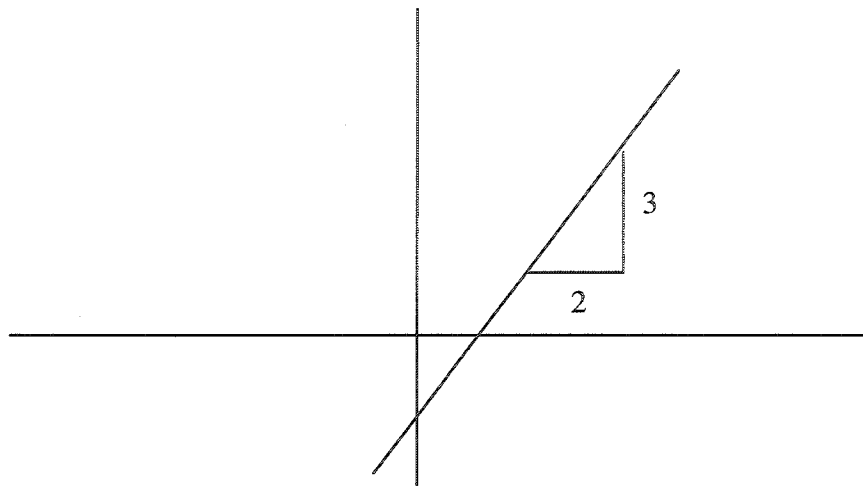

Figure 14: Greg's work on another slope problem

He asked what the equation was (It was clear he meant $y = mx + b$). I said I wasn't sure. He asked what b was, and I replied that from the diagram it was about -2 or -3. "Too bad we don't know the equation, because then we would know the slope." Without question, his knowledge of lines was extremely limited. But just ten minutes before working on this problem he claimed that the calculator was "very helpful" in learning about lines, and he felt that its use gave him an excellent understanding of them. This is clearly not true. He knows a bit about lines, and perhaps his calculator helped him gain this limited understanding. Again, the point of Greg's examples is not to show his absence of understanding of lines. The point here is that he has such an absence while claiming that his calculator helped him gain such an understanding.

Example 5:

This was some work that took place about halfway through the semester. Freda had told me on several occasions that her calculator was instrumental in helping her to understand quadratic functions and their graphs. She said that she felt “comfortable” using it to graph and analyze such functions. During one of our interviews, she was working on the following problem, trying to find the lowest point on a parabola. Her work is shown below in Figure 15.

Find the lowest point (x, y) on the following parabola: $y = x^2 - 10x + 13$.

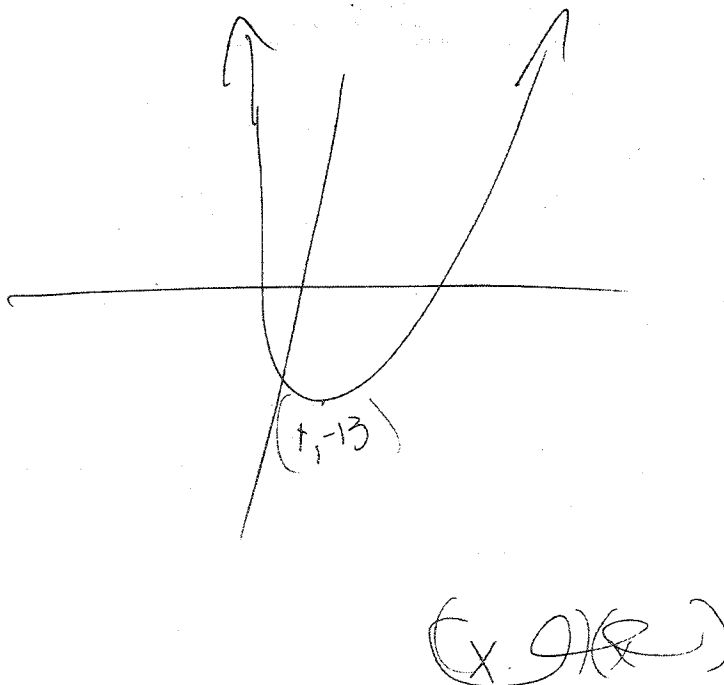

Figure 15: Freda's work on a minimization problem

Her answer was the point (1, -13). When I asked her how she got the answer, she told me the coefficient of the x squared term and the number “at the end” determined the (x,y) coordinates of the lowest point. Her answer was, of course, incorrect. Further conversation revealed that she had misapplied a shortcut to find the lowest (or highest) point on a parabola. The “shortcut” that she misapplied (and “remembered” when we talked about it) reveals that a parabola in the form $y = (x-h)^2 + k$ has a vertex (highest or lowest point) at the point (h,k). But since the parabola given in the problem was not in this form, she got the wrong answer. She also tried to factor the quadratic as seen at the bottom, but could not explain how this would help find the lowest point. Interestingly, even though she claimed that the calculator helped her to learn about quadratic functions, note that she did not use the calculator to answer this question. She also had trouble working problems with quadratics later on in the semester, and during the exit interview. For instance, she was unable to provide an example of a quadratic equation with one or zero solutions. On another occasion when graphing a quadratic function, she was not able to recognize that she had made an input error. The shape of the graph was so clearly incorrect that she should have suspected some sort of calculator error. Clearly, contrary to her belief, her understanding of the graphs of quadratic functions was not as great as she claimed. Freda’s belief that the calculator helped her to learn this topic was clearly overstated.

Example 6

This example comes from Isaac's exit interview. He reported that the calculator "definitely" helped him understand lines. He credited the graphical nature of the calculator, the instructor's explanations while using a calculator during lectures, and using the calculator to do homework. He exhibited quizzes and exams in which he had correctly answered problems dealing with lines. In this problem, he is trying to find a relationship between Fahrenheit and Celsius, which he has been told is linear. His work is shown here in Figure 16.

- 1) 32 degrees Fahrenheit equals zero degrees Celsius. 212 degrees Fahrenheit equals 100 degrees Celsius. Find the relationship between Fahrenheit and Celsius.

X	Y
32	212
0	100

$$\frac{\Delta Y}{\Delta X} = \frac{100 - 212}{0 - 32} = \frac{-112}{-32} = \frac{7}{2}$$

~~C = F~~ ~~(C - 32) = 0~~

$C \frac{7}{2} = F$

Figure 16: Isaac's work on the Fahrenheit and Celsius problem

His answer, $F = \frac{7}{2}C$ was incorrect. (A closer look at the table he made reveals a serious misunderstanding of the relationship between the variables F and C.) I asked him if he could verify his answer, but he wasn't sure how. I suggested graphing the line,

but he seemed a bit puzzled. He first said that he wasn't sure how to graph the line, because it didn't have a "b". I then suggested that perhaps we could rewrite the equation $F = \frac{7}{2}C$ as $y = \frac{7}{2}x$, and then asked if that would help. He persisted in saying that the lack of a "b" would prevent him from graphing the line. He then said that it wasn't necessary to graph the line. Since he had the right slope, he definitely had the right answer. He seemed to be obsessed with the slope, and felt that since he had found the slope, he had gotten the right answer. (Note: during the exit interview, I reviewed this problem with him, and cleared up his misconception about not being able to graph a line without a "b".) Isaac believed that his calculator was helping him; the reality was that his knowledge of the topic was quite limited. It is possible that the calculator gave him help in gaining his limited understanding, but his belief was clearly overstated.

Examples 7, 8, and 9

Janet was quite sure that she had really learned "a lot" about lines, quadratic functions and equations, and systems of equations. All throughout the semester, she claimed that her knowledge was growing more and more meaningful, although it seemed (to the researcher) that much of her knowledge was superficial. During the exit interview, she claimed that the calculator was quite helpful in learning about each topic. Specifically, she mentioned the calculator's ability to check her answers, to graph things

easily, and to, in her words, “investigate and try things out when you’re not sure what to do.” In the following problem, seen below in Figure 17, she was trying to solve what turned out to be a quadratic equation.

2) Solve for x:

$$\frac{x}{1} + \frac{1}{x} = 4 \quad \left(\frac{x}{1}\right)$$

$$x^2 + 1 = 4x$$

$$x^2 - 4x + 1 = 0$$

$$(x - 3)(x + 1)$$

$$x = -3 \quad x = 1$$

$$\boxed{-3 \quad +1}$$

$$1 + 1 = 4$$

Figure 17: Janet’s work on a quadratic equation

She factored the equation incorrectly, but never detected her error. I asked if she could check her work, but she said she was unsure how to do so. I asked if the calculator could be of help. “I don’t see how,” she said. “I’m not sure if this is the right answer. If I

were smarter, I'd just find the formula and plug it in!" I asked her if she knew another method for solving quadratic equations, other than factoring. "Oh, they always factor," she replied. (Note: other possibilities include the Quadratic Formula, Completing the Square, looking for x-intercepts on the graph, any or all of which should be in the skill set of someone with a good grasp of quadratic equations.) It is quite clear from this example, that despite her belief that she understands how to solve quadratic equations, she does not. She has a very limited knowledge of quadratic equations And this makes her claim that the calculator has helped her to do so indefensible.

In the following example, Janet displayed several misunderstanding about lines. The problem asks to find two points on a line which are equidistant from a given point. Her work on the problem is shown in Figure 18 below.

- 4) Find the two points on the line $y = 2x + 1$ that are at a distance of 3 from the point $(3,4)$

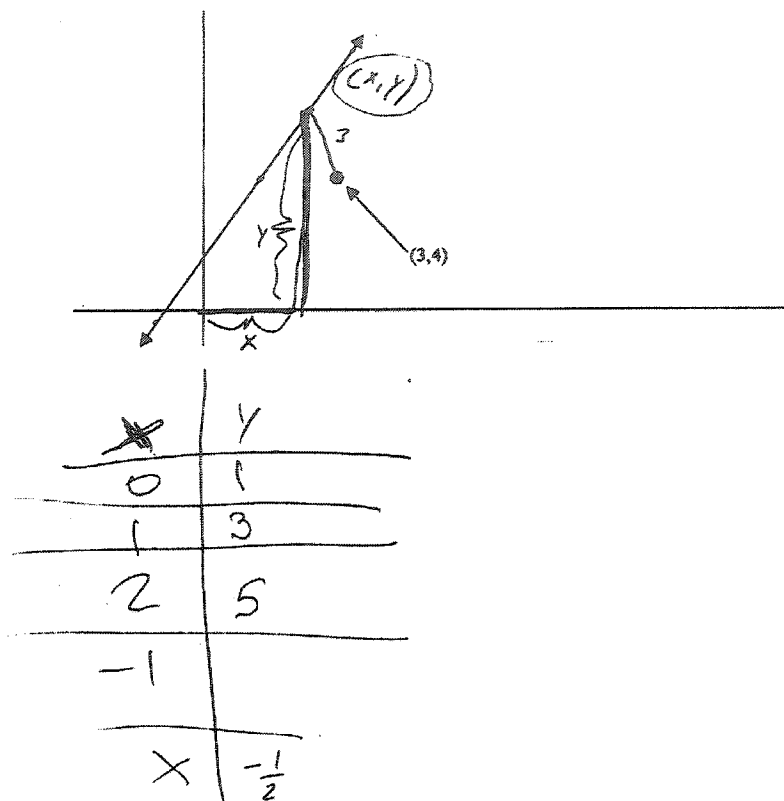

Figure 18: Janet's work on a distance problem

Her inability to properly use the distance formula in this case is important, but not the most telling. She said several things which betrayed her lack of understanding about lines. The first was her insistence that the points in question “must be integers.” She went on to say that the coordinates of the two points must be integers such as $(2,6)$ or $(1,2)$, which of course is not true. In fact, the correct points do not have integer coordinates. The second thing that she said that was incorrect was that the segment joining the point that was a distance of 3 from the point $(3,4)$ will be perpendicular to the line $y = 2x + 1$, which is also untrue. She never gave an answer to the problem.

In the third example, Janet is to find a certain distance between two points on a line. Janet correctly began to think that one way in which the problem could be solved was by using two variables, one assigned to the difference between the x-values of the two points, and another assigned to the difference between the y-values. The first line of her calculations offers a bit of evidence that she understands the distance formula. Figure 19 shows a reproduction of her work: (Note: as she defined the variables, x represents the x- coordinate of the point in question, and y represents its y-coordinate.)

- 2) The point (1,5) lies on the line $y = 2x + 3$. If you travel a length of 4 along the length of the line, at what point would you be?

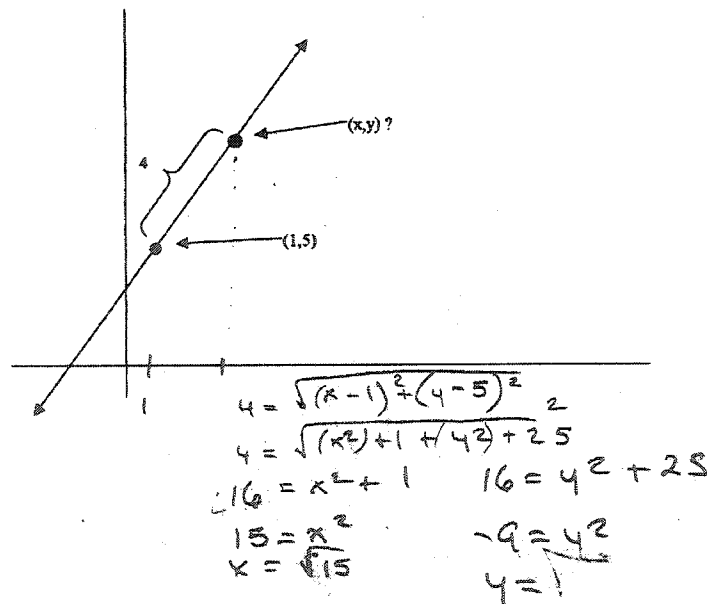

Figure 19: Janet's work on a system of equations problem

At this point, given her approach to the problem thus far, if she truly had at least partial understanding of the idea of a system of equations, she would have recognized

the need for a second relationship between x and y , given that she already has one such relationship, the one correctly rendered in the first line of her work. The idea that given two unknowns, that *two* relationships between the two variables are necessary, is fundamental to understanding the concept of systems of equations. Even after I tried to jog her memory, hinting about the need for another equation, she did not recall the need for another equation. Following a lengthy pause after writing the first line, the pause that clearly indicated her deficient knowledge of systems of equations, she made some algebraic manipulations that are likely to curl the toes of just about any math teacher. But her lack of skills in basic algebraic manipulation does not obscure the fact that her knowledge of the central concept of systems of equation, despite her claim, is poor at best.

The key point here is not that she lacks a good knowledge of the concept of systems of equations; many of her classmates did so as well. What is key is that she has come to believe that her calculator has given her an understanding which she clearly does not possess.

After she gave up on this problem, I gave her an example of two equations with two variables, a problem in which she was to find the point of intersection of two lines. The two lines were $y = -x + 5$ and $y = x + 1$. She promptly “solved” it with her calculator, although she was unsure what the “solution” represented. It seems likely at

this point that when she claimed that she “understood” systems of equations, she was referring to the type of system that can be “solved” on the calculator, when the two equations are provided. She was neither able to interpret what the “solution” represented, nor did she seem to realize that the algebraic manipulation of one equation with two variables in it would not lead to a solution in the absence of an additional relationship between the two variables. These central ideas of system of equations were not clear to her.

The above example also provides evidence that her knowledge of lines is poor, because although she believed the x coordinate was $\sqrt{15}$, she was unable to find the y-coordinate for that point, even though the equation of the line was given. (This may go back to her earlier belief that some points must have integer coordinates.)

Examples # 10 and # 11

Example 10 is taken from Michele’s exit interview. Michele had for most of the semester been speaking quite highly of her calculator, and how glad she was that the instructor and the person who led the lab sessions used it for demonstrations. She felt that such demonstrations helped her make sense of the class material. She also commented on how easy it made her homework. On several occasions, she told me that it was used more here in the University mathematics classes than it had been used in

high school, and she was finally glad to be able to use it, since she had spent more than \$100.00 for it. Now, during our exit interview, she continued to maintain that the presence of the graphing calculator had helped her “get a lot out of the class.” Example 10 is a simple equation and can be solved in several ways detailed in the class, with or without the calculator. (Note: the more important point made here in this example is what she did not do with her calculator.) Figure 20 is a reproduction of her work:

4) Solve for y. $\frac{4}{y} - 5 = \frac{5}{27}$

~~$\frac{4}{y} - 5 = \frac{5}{27}$~~

$\frac{5}{27} + 5 = \frac{4}{y}$

$(\frac{5}{27} + 5)y = 4$

$y = \frac{4}{(\frac{5}{27} + 5)}$

$\frac{5}{27} + 5 = \frac{10}{28}$

Figure 20: Michele’s work on a simple equation

Note the point at the bottom left where she wrote $y = \frac{4}{\frac{5}{27} + 5}$. At this point, she

could have used the calculator to find the desired answer, even in its complicated form.

(I thought she would do so, for she was quite aware of her poor basic math skills.) She

simply wanted to stop and leave it in that form. When I pressed her to simplify the expression, she made a mistake while adding the fractions (which I illustrated for the benefit of the reader in the lower right of the image.) She eventually got 11.2, the wrong answer, but didn't check it in the original problem. I asked if she could check the answer, and she replied that it was too much trouble by hand (which was likely true, in her case.) I asked if she thought the calculator might be helpful in checking the answer. She replied, "How could the calculator help to do that?" I first suggested that she use the calculator to replace the y with 11.2, and she again replied that she didn't know how to do that. I showed her and demonstrated that her answer was wrong. She seemed surprised that I could use the calculator like that. At this point I showed her how the calculator could have saved her a bit of time, by calculating the original expression

$\frac{4}{\frac{5}{27} + 5}$. As I performed the operation on her calculator, she expressed surprise that this

could be done. She said that she wished that she had known that this was possible. I also showed her how to analyze the problem by graphing both sides of the equation and interpreting the intersection of the two lines. This caused her even more surprise (she said it was "neat"). Despite her claims that the calculator was helping her "to get a lot out of the class," she seemed ignorant of even the most basic methods of utilizing it in this context. She was unable to use the calculator here in at least three substantive ways: (1) the simplification of the complex fraction, (2) neglecting to use the capability of the calculator to check her work, and (3) overlooking the use of a graphical view of the

equation. These three uses should certainly be part of the repertoire of any student who is using a graphing calculator with any degree of facility.

In the second example, Example 11, she made a mistake while doing a multiplication problem by hand. (By the way, the multiplication that she performed, even if done correctly, would have produced the wrong answer.) Again, she did not wish to check the answer, because she thought that meant that she had to do it by hand. Here is a reproduction of the work, shown below in Figure 21.

- 5) The Nasdaq stock market index is down 15% for the year, and currently stands at 3,277.60. What was the index at the beginning of the year?

$$3,277.60 \cdot 15\%$$

$$\begin{array}{r} 3,277.60 \\ \cdot 15 \\ \hline 16388.00 \\ 327760 \\ \hline \$49164.00 \text{ at beginning of the year.} \end{array}$$

Figure 21: Michele's work on a percent problem

It seemed a bit odd that she did the multiplication by hand. I asked her why she did not perform the calculation with her calculator. She responded that she was

accustomed to using her calculator for graphing, finding points of intersection, and finding maxima and minima, “the real math,” as she put it. However, during the next few minutes of our conversation, she admitted that her lack of basic skills sometimes prevented her from successfully interpreting the output of her calculator in these cases. For example, I asked her to find the minimum point on a parabola, and she used her calculator successfully to find it. I asked her why it may have been important to find the minimum, and she wasn’t sure. Once again, the real point here is not that a student is struggling to use her calculator. The point is that she is struggling to use it, and yet reports that it is helping her more than it is actually is. The extent to which the calculator has given her some limited help is uncertain. But she was certainly overstating the ways in which she was using it. Recall that her primary response to why it was helping is that she was watching other people use it for demonstrations. But despite watching others, her own understanding of what the calculator can and cannot be used for was still quite fuzzy.

Example 12

Paula was quite sure that her knowledge of systems of equations was “excellent.” She said she was confident that she could “solve any one that you throw at me.” During her exit interview she reported that her calculator was very useful in her achieving this “excellent” understanding. The following example demonstrated clearly that when she

spoke of solving “any one you could throw at her,” what she in all likelihood meant is problems in which the equations are already given, and can be entered into the calculator. Indeed, she was quite easily able to solve ready-made systems on her calculator. The quizzes and exams she produced showed that she could solve systems if the equations were provided. On several occasions in which she used her calculator she was able to recognize input errors and correct them quickly. But the following problem is one in which the student must generate the equations by himself or herself. Her work on the problem is shown below in Figure 22.

Extra Credit: The point $(1,5)$ lies on the line $y = 2x + 3$. If you travel a length of 4 along the line, at what point would you be?

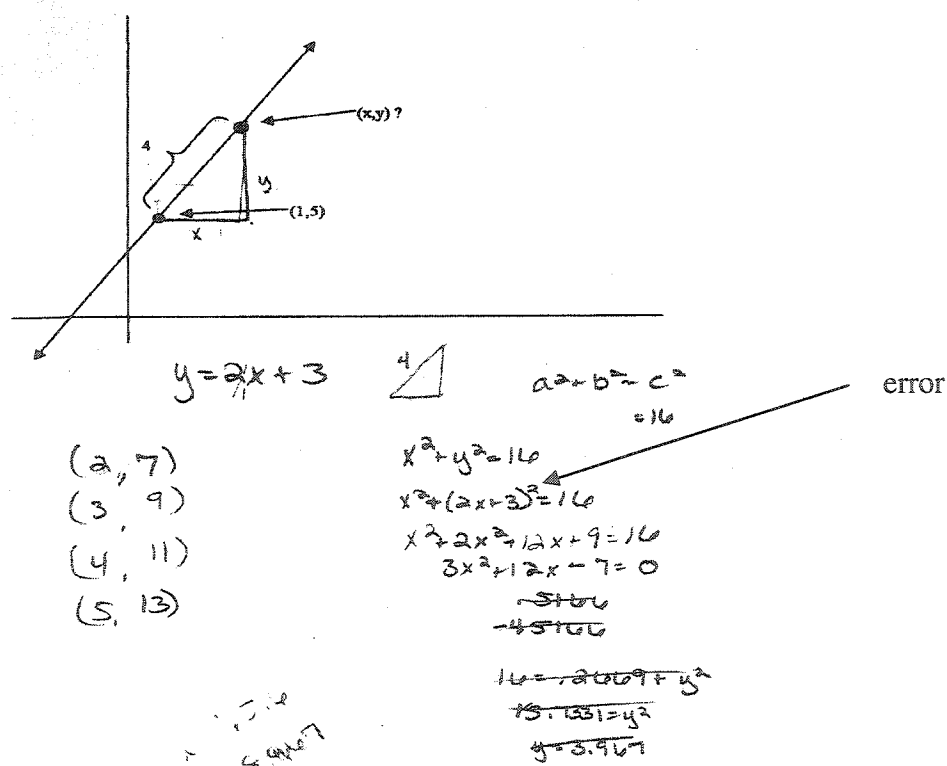

Figure 22: Paula's work on a system of equations problem

She assigned the variables x and y to the two legs of the triangle that she drew, and correctly identified one relationship between x and y to be $x^2 + y^2 = 16$. She then correctly recognized (and said out loud) that if she could find one more relationship between x and y , she would have a system of equations, and then she could solve for x and y . Though she recognized the need for this additional relationship, it eluded her. She spent the next several minutes quietly thinking. Setting up the problem as she had thus far, the next relationship should have been $y = 2x$, because the slope of the line is two, and so $\frac{y}{x}$ is clearly equal to 2, as she had defined the variables. However, eventually she saw the equation of the line as the second relationship, namely $y = 2x + 3$. This is of course an incorrect relationship between x and y .

It may occur to the reader that using variables other than x and y would have caused her to solve the problem correctly. However, when I, on a separate sheet of paper, rewrote the problem again and actually wrote a and b where she had written x and y , she made the same mistake. But the equation of the line of course, $y = 2x + 3$, has nothing to do with the relationship between the x and y as she has set up the variables. The arrow in the diagram shows where she utilizes the faulty relationship between x and y , which of course led to the wrong answer. Our subsequent discussion, after we had agreed that she indeed had the wrong answer, revealed that she felt that “you have to use $y = 2x + 3$, because it’s in the problem.” Her success in solving systems of equations when provided with the equations is certainly a positive step, but clearly she possesses

an ignorance of the deeper significance and subtlety of the systems concept. Her knowledge of the systems concepts was very superficial, despite her claim that she had an excellent understanding. (Note to the reader: After I was convinced that my data collection for her was complete, I was careful to point out her error, solved the problem through to the end, and went through some other examples, similar to this problem, in which the equations are not given, but must be “discovered.”)

Example # 13

This is some work of Linda, who claimed all throughout the semester that she was “getting” logs. During her exit interview, just a few days before the final exam, she was satisfied that not only did she understand logarithms and how to solve equations with logs in them, but that the calculator had been “crucial” in helping her to gain such understanding. She especially mentioned the classroom demonstrations in which the calculator was used to discuss logarithms and their applications. She said, “I could never have learned this without my calculator.” Figure 23 shows the work, completed just five minutes after she had claimed that she “knew what was going on with logs.”

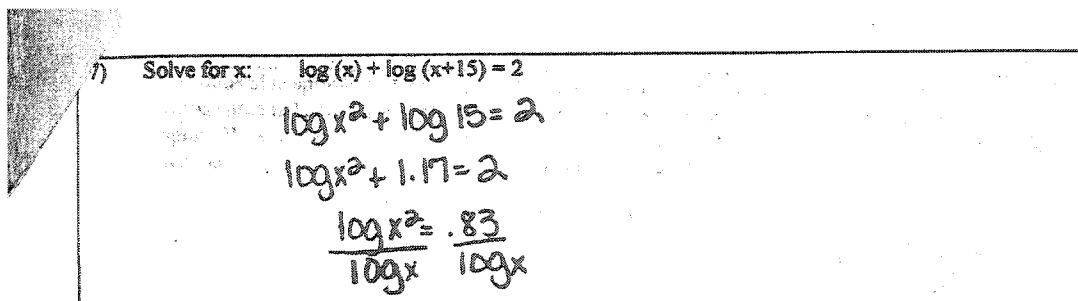

7) Solve for x: $\log(x) + \log(x+15) = 2$

$$\log x^2 + \log 15 = 2$$

$$\log x^2 + 1.17 = 2$$

$$\frac{\log x^2}{\log x} = \frac{.83}{\log x}$$

Figure 23: Linda's work on a logarithm problem

After she stopped, and said she was stumped, I asked her to justify the first step she had written, which is completely false. She said something about logs being added and multiplied and seemed to think that the first step was OK. She admitted the last step was suspect, and said she was stuck. We talked a little bit about the laws of logarithms, and it was clear that she had little knowledge of them. We checked the book for a list of the log laws, but when I asked her to give me an example of some of them, she could not. She even denied a connection between logarithms and exponents, which is of course crucial to having a good understanding of logarithms. I then suggested something which surprised her. I asked if she knew that she could solve the equation by graphing both sides of the equation and looking for a point of intersection. She said that she didn't think you could graph the left side of the equation, "because it had two logs in it. I know how to graph one log, but not two." (Using a different example, I briefly showed her that this was indeed possible.) Given this knowledge, I asked her if she could see a way to discover if her first step was indeed valid. After some thought, she correctly stated that you could graph the left side of the original problem, and the left side of her

first step, and see if they looked like exactly the same graph! Her excellent reasoning and that she was able to invent, in just a few moments, an imaginative use of the calculator, led me to believe that in saying that the calculator was helping, she was correct insofar as earlier in the semester she was able to remember the steps to solving the problem, whereas now she had forgotten them. She had used the calculator to solve such problems in the previous weeks, but had not retained this knowledge. When I asked her if it was possible that she had once “known” but had now forgotten how to do these kind of problems, she immediately agreed. Evidently, her claim that the calculator had been helpful can only be seen as valid if it is believed that such knowledge needs to be retained for a few weeks. (Interestingly, this was quite a common view among almost all the students in the classes. Many students, both supersubjects and otherwise, were not at all uncomfortable with the realization that their knowledge was superficial, and seemed resigned to the fact that the knowledge that they were “gaining” seemed to be fading after not touching the subject for a week or two. Others were more cynical when contemplating that after the class was over it was quite likely that they would remember little, if any of the class content.)

Linda’s belief that the calculator had helped her is suspect because even if you grant that she was able with the help of the calculator to solve logarithms during the semester, her performance at the end of the semester demonstrated that any insight that she had gained during the semester seems to have disappeared. Her knowledge of

logarithms, being superficial, had now, just a few weeks later, melted away. She could not give examples of the laws of logarithms, even when looking at them, she could not comment on the crucial connection between logarithms and exponents, and she did not feel that she could graph an equation “with two logs in it.” It is important to note that many of the students in the class struggled with logarithms. Others even claimed that they knew more about logarithms than they actually did, just like Linda. But Linda attributed at least part of her supposed knowledge of logarithms to her calculator. She clearly overstated her knowledge of logarithms and gave some of the credit to her calculator.

Example 14

This example shows the work of Oliver during his exit interview. It is essentially the same as Linda’s experience in the previous example. Like Linda, Oliver gained only a superficial knowledge of logarithms and believed that the calculator was helping him, when in reality his belief was based primarily on seeing demonstrations of others using the calculator. His experience also was such that he had relied on his memory in order to solve logarithm problems on previous assessments, and he had evidently “forgotten” how to do them. The work is shown here in Figure 24.

$x = 4.4$

7) Solve for x: $\log(x) + \log(x+15) = 2$

$\frac{16}{0} \frac{1.2}{0}$ $\frac{\log(x+15)}{\log x} = 2$

2 $\frac{\log 17}{\log 2} \frac{1.2}{.30} = 4$ 19.7 $\frac{1.294416}{.672097}$

3 $\frac{\log 18}{\log 3} \frac{1.255}{.4771} = 2.63$ 4.4 $\frac{1.2922}{.6627}$

4 $\frac{\log 19}{\log 4} \frac{1.278753}{.6020599} = 2.12$ 19.4 $\frac{1.28780}{.64345}$

5.5 $\frac{\log 20}{\log 5} = \frac{1.30102}{.698970}$ $\frac{\log 19.5}{\log 4.5} \frac{1.290}{.6532}$

Figure 24: Oliver's work on a logarithm problem

His answer, 4.4 is incorrect. I suggested that perhaps he could use the calculator to check his answer. "Do you mean by graphing, because I don't think you can graph two logs." I asked if there was another way to check it, aside from graphing. He then substituted his answer, 4.4, into the equation, and discovered that his answer was incorrect. He did not know how to do the problem differently. I worked the problem correctly for him, discussing the relevant logarithm rules along the way and got an answer. I then showed him how to graph the left side of the equation and find when it was equal to two. My answer was corroborated. He was pleased with the idea of graphing the equation, and agreed when I mentioned it that he had witnessed this technique both in class and also in the lab sessions. He had seen the technique of graphing the two sides of the equation, but recalled it only when I demonstrated it. The real issue, again, is not that a student struggled with a logarithmic equation. It is that he

could have such little grasp of a topic, and yet report that the calculator helped him to understand this same topic. Several other students had difficulty with logs and still reported that they understood the topic, but unlike Oliver (and Linda in the previous example,) did not report that the calculator helped them.

Example 15 concerns a student named Cathy, who by all accounts, had mastered exponential functions and equations. Cathy had solved every problem of this type on every assessment during the semester with little difficulty. And she insisted that the calculator was very helpful in helping her to do such problems. She spoke highly of the instructor's use of the calculator in giving examples of these types of problems and solving them with the calculator. During our one-on-one sessions she had no difficulty with such problems, but I noticed that she was reluctant to talk while working on the problems. Below in Figure 25 is an example of her work during the semester, which involves the use of the formula $\text{Amount} = Pe^{rt}$. (e in the formula is a mathematical constant, equal to approximately 2.71828.) These types of problems customarily deal with the growth of investments if they are compounded continuously, or the rate of growth of natural phenomena such as bacteria or timberwolves.

3) In a pond there are 1000 mosquitoes at the beginning of an experiment. After 2 days, there are 2000 mosquitoes. How many mosquitoes will there be after 4 days? Assume the rate of growth is the same for all 4 days.

$$A = Pe^{rt}$$

~~2000~~ ~~1000~~ = 1000 $(e)^{2.71828 \cdot 2}$

$$2000 = 1000 (2.71828)^{rt}$$

3,999 mosquitoes $\div 2 = (2.71828)^{rt}$

$$\ln = \frac{0.693147}{2} = r \cdot 2 = .34657 = R$$

1000
 $10^3 \cdot 10^{.34657 \cdot 2}$
 $10^{3.693147}$
 3.999

Figure 25: Cathy's work on an exponential growth problem

She solved a similar problem during the exit interview, but despite my encouragement to explain each step of the problem, she was nearly silent during the problem. Just as she was leaving the exit interview, Cathy turned around and said, "I've always wondered about something. What is that e thing, anyway, ten?" I was caught completely off-guard. How was it possible for her to not know the value of a mathematical constant that was instrumental in solving the problem? Given her remark, it seemed likely that her knowledge of the topic was mostly superficial. Her silence while working such problems indicated that, in all likelihood, she had simply memorized how to do such problems. It was certainly not the intent of the instructor for a student to be able to work the problems without understanding what the value of e

was. Looking back on the audiotapes of my interviews with her, a similar lack of discussion characterized her problem solving sessions in person with me. Was this the only topic in which she was able to work problems with limited knowledge?

She was one of the students who didn't want the tutoring and chose instead the gift certificate to a local restaurant. I tried to contact her before the final, but it didn't matter. She was one of the students who replied when I sent a thank-you email to the participants. She mentioned that she aced the final and got an A in the course. (This is, of course, a serious issue and speaks to the idea of naïve assessments. This issue will be addressed in the next chapter.)

To reiterate, the point should be made again here that the real issue is not that the students could be showing misunderstanding of these topics; the real issue is that they are reporting that the calculator is helping them to understand these topics, but yet they do **not** understand the topics. It should also be mentioned that all of the students included in the discussion of the above research question all passed the class, the lowest grade in the group being a C+. How can it be that students with such a poor grasp of a topic nevertheless not only profess a better grasp than they have, but give much of the credit to a piece of technology? How is it that they seem to have little trouble with in-class assessments, but yet later reveal misunderstandings and misconceptions of the use of their calculators? Not surprisingly, many students retained skills learned in class for

a very short period of time. Is it possible that the presence of the graphing calculator contributed to this lack of retention in certain subjects? These questions will be discussed in Chapter V.

Research Question 2b) Are there students who feel the calculator is helping them to understand class topics but in reality they came to an understanding of the topic, but the calculator was of little use to them in doing so?

This has proven a very difficult question to answer in the affirmative, because it is impossible to be present at all times when students might be helped by their calculators. Two students who seemed to grow in their mathematical knowledge, attributed much of this progress to their calculators, but the evidence suggests that they were overstating the role the calculator had.

The first example is that of Alex, who seemed to grow very knowledgeable about exponential and logarithmic functions and equations. He claimed that the calculator was important in his increase of knowledge of the subject. Figure 26 shows an example of Alex's work solving a logarithmic equation. The first line, the problem itself, is in my handwriting:

Handwritten work on a logarithmic equation:

$$\log x + \log(x+15) = 2$$

$$\log(x(x+15)) = 2$$

$$\log(x^2 + 15x) = 2$$

$$10^2 = x^2 + 15x$$

$$x^2 + 15x - 100 = 0$$

$$(x+20)(x-5)$$

$$x = -20, 5$$

Figure 26: Alex's work on a logarithmic equation

Alex solved the equation correctly, and checked to see that one potential answer, 5, was indeed a solution. He also clearly understood that the negative 20 could not be a solution, explaining quite convincingly that the logarithms of negative numbers are not defined. In the above example, he used several logarithm and exponent rules properly and was able to clearly explain them when asked. This example is typical of his solutions to several exponential and logarithmic problems that he worked correctly while working with me one-on-one. He showed me some of his exams in which he had no difficulty with such problems. Unlike the young woman who did not know what the mathematical constant e was, he was able to explain what e was, showing how it was

derived from the definition of increasingly compounded interest. His knowledge of both exponents and logarithms and their application mentioned in the class was impressive.

What caused me to doubt that the calculator was as useful as Alex claimed in helping him understand the topic of exponential and logarithmic functions and equations happened shortly after he had solved the above problem. I asked him if there was an alternative way to corroborate his answer. He replied that he did not think so. When I suggested to Alex that we could graph both sides of the equation and verify our answer, he seemed fascinated by the idea. Below in Figure 27 is the graph I showed him on his own calculator, which is the graph of the function $y = \log(x) + \log(x+15)$. Note that the function has a value of 2 when $x = 5$, verifying Alex's answer.

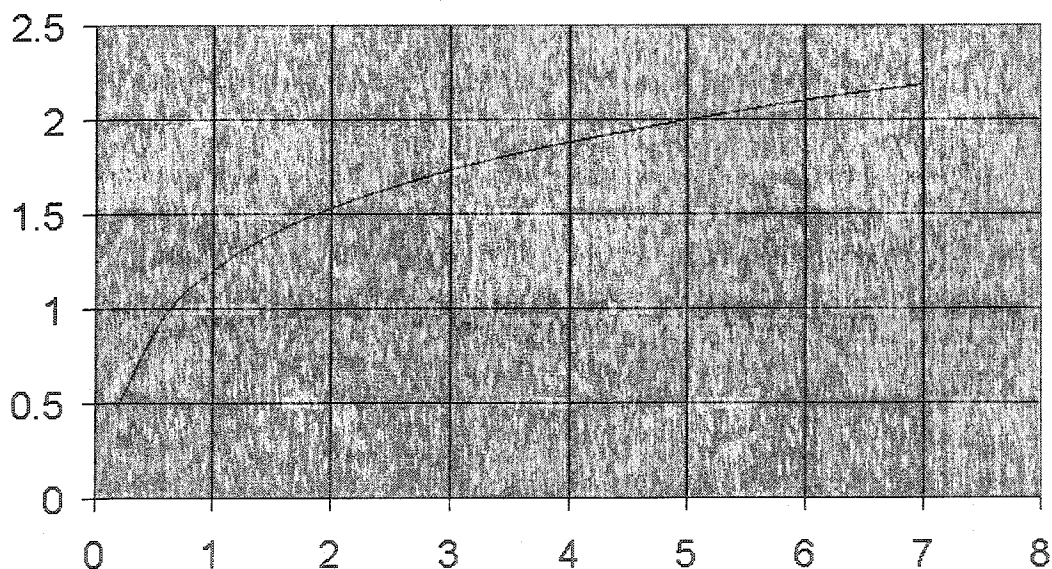

Figure 27: Researcher's use of the calculator while with Alex

He expressed great pleasure at seeing this graph on his own calculator and wondered (aloud) why he had not seen this before. It made me wonder that if his calculator had truly been instrumental in helping him understand this topic, why is it that this idea was new to him?

A second situation made me question the usefulness of the calculator in helping him understand this topic. Once, when he was graphing a log function, I noticed that because of an input error involving parentheses, he generated an incorrect graph. However, he did not notice it immediately. I questioned the look of the graph, and after a minute or two he recognized the error, but had some difficulty inputting the correct formula into the calculator. He finally got the right graph, but only after struggling with the calculator buttons and syntax a bit. His knowledge of logarithmic functions helped him to spot the error after I pointed it out, but yet he seemed a bit unfamiliar with how to correctly enter them into his calculator. It made me wonder how this could be so if the calculator really had been central to his process of understanding.

A third situation made me wonder about the calculator's role in the process that led Alex to his understanding of this topic. On certain occasions, he seemed to be a bit confused as to which button to use when dealing with natural logarithms versus standard (base 10) logarithms. Occasionally, he would talk about which button he

should use. He clearly knew the difference between the two types of logarithms and when to use each. But his confusion about which button was which seemed to indicate that the calculator had not been as useful as he had claimed. His mastery of the topic was quite good; there was little doubt that Alex had an excellent grasp of the topics of exponential and logarithmic equations and functions. However, his claim that the calculator helped him to understand the topic seemed to be overstated.

The second student who fit into this category was Elmer. His knowledge of all of the major class topics was excellent. In all of our one-on-one interviews, he was able to solve the majority of the problems with ease. He was expecting an A in the class. His perception of the usefulness of his calculator was consistent throughout the semester as well as in our exit interview. Each of his references to his calculator was positive. He always spoke highly of his graphing calculator, and on many occasions credited it with helping him to gain an understanding of the class topics.

However, in all the observations I made of Elmer when he had an opportunity to use his graphing calculator, I never observed him personally using it for anything other than simple calculations such as addition, subtraction, multiplication, division, and taking square roots. He used the calculator frequently, but was never observed using any of the calculator's advanced functions such as graphing, algebraic manipulation, finding minimums and maximums, equations solving and the like. I never saw him follow along

when the instructor or the teaching assistant gave calculator demonstrations, and he never used any advanced calculator function in all the time he spent with me in our one-on-one interviews. He almost always used the calculator for simple arithmetic. The only exception was when he was observed using the graphing calculator to calculate logarithms and trigonometric ratios. He probably would have found a standard scientific calculator more than sufficient for his use.

So although he reported that his calculator had helped him, he was observed to be using only a small percentage of the calculator's actual capabilities. His perceptions may have led a casual observer to conclude that the advanced features of the calculator must have helped him. He did indeed have a good understanding of the class topics, but the advanced features of the calculator did not contribute to his gain in understanding. He probably did benefit from the use of the calculator, but he could have achieved the same results with a standard scientific calculator not having any advanced features.

Research Question 3a) Might a student maintain the calculator was not useful in learning a certain topic but in reality the student was actually observed using the calculator in substantive ways, but may have dismissed such uses or forgotten them?

One such case stood out. Helen progressed well during the semester in her knowledge of both lines and quadratic equations and functions. Not only was she able to solve standard problems dealing with these topics, she was quite good in understanding

the application of the topics. She was able to clearly recognize linear or quadratic situations when they appeared in problems, even in types of problems that she had clearly never seen before. During the semester, she performed quite well on these types of problems on quizzes and exams, in the lab sessions, as well as her work with me. Helen agreed with me that she seemed to be progressing in her knowledge of these topics and was always pleased with her current grade in the course. She expected to get an "A." During the course of the semester, it became quite clear to me that she was using her calculator in very useful and even creative ways to improve her understanding. She seemed to be benefiting from others' use of the calculator as well, as I witnessed her on several occasions imitating calculator uses and procedures that had been modeled in her presence. It was also clear that such behavior was not the result of previous experience, because my observations during the calculator training made it evident that she did not have much experience with the graphing calculator before this class. This was corroborated by her own statements about her past graphing calculator usage, which she said was minimal. I had no doubt that the calculator was playing a very important role in her ongoing mastery of both linear topics, and the use of quadratic functions and solving quadratic equations. However, when we talked about the calculator in her exit interview, she said that she didn't think the calculator played a big role. She could not recall specific instances in which she felt the calculator proved useful, and downplayed its importance. I asked her if she could recall any calculator demonstrations by either the instructor or the lab assistant that seemed to help her, but she could recall none. Despite

my belief that the calculator had helped her in various ways, she seemed to think that it was not that useful.

This is the first example which made me believe that the calculator was playing more of a role in Helen's progress than she believed. In the following work from the middle of the semester, shown in Figure 28, Helen solved the following equation algebraically, and got the correct answer, which is -30.

1) Solve for x:

$$\frac{x}{6} = \frac{5}{2} + \frac{x}{4} \quad -30$$

$$4(\cancel{24}) \frac{x}{\cancel{6}} = \frac{5}{2} \frac{(\cancel{24})^{12}}{\cancel{2}} + \frac{x(\cancel{24})^6}{\cancel{4}}$$

$$4x = 60 + 6x$$

$$4x - 6x = 60$$

$$-2x = 60$$

$$x = -30$$

Figure 28: Helen's work on a linear equation

Without any prodding on my part about checking her answer, she immediately graphed both sides of the equation simultaneously on her calculator, as pictured in the following graph: She had to experiment a few times to find the right viewing window, but eventually saw something like this, shown in Figure 29:

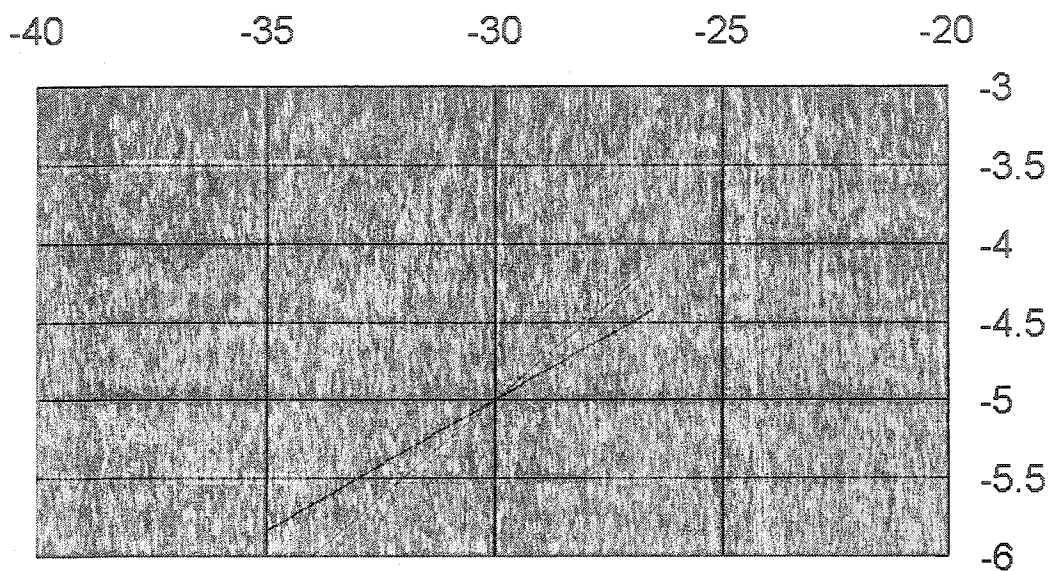

Figure 29: Helen's work with a calculator corroborating an answer

She was quite pleased with the fact that lines crossed at $x = -30$. To me, this represented a compelling role which the calculator was playing in her understanding of equations and lines. But she seemed not to consider such a use worth mentioning, or else she had forgotten about it. To spontaneously use the calculator in such a way was unusual among the subjects.

In the next example Helen solved an equation using the quadratic formula and got two approximate answers, 3.72 and 0.267. The paper work is reproduced here in Figure 30.

2) Solve for x:

$$x + \frac{1}{x} = 4$$

$$1\frac{3}{4} + \frac{1}{3} = 4$$

$$x + \frac{1}{x} = 4$$

$$(x)x + \frac{1}{x}(x) = 4(x)$$

$$x^2 + 1 = 4x$$

$$x^2 - 4x + 1 = 0$$

$$\frac{-(-4) \pm \sqrt{4^2 - 4(1)(1)}}{2(1)}$$

$$\frac{4 \pm \sqrt{16 - 4}}{2}$$

$$\frac{4 \pm \sqrt{12}}{2}$$

$$\frac{4 \pm 2\sqrt{3}}{2}$$

$$3.73$$

$$1.267$$

Figure 30: Helen's work solving a quadratic equation

Once again, as in the previous example, she graphed both sides of this equation, and got the graph reproduced below in Figure 31. The graphs are $y = x + \frac{1}{x}$ and $y = 4$.

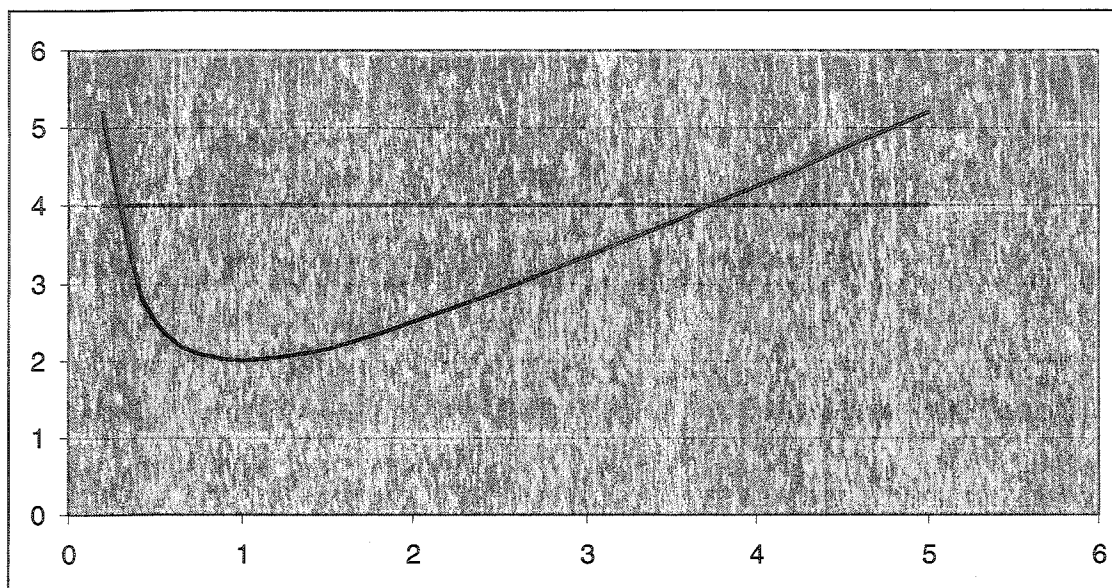

Figure 31: Helen's work with a calculator corroborating another answer

She changed the viewing window several times before convincing herself that the graphs crossed at her approximate answers, 3.72 and 0.267. I asked her why these intersecting curves corroborated her answer. She answered with a clear, intelligent explanation which was quite convincing. I viewed this behavior as more evidence that the calculator was playing a more significant role than Helen believed.

Another example shows how Helen used the calculator to discover an error. In solving the following problem, Helen made an algebra manipulation error, and got an incorrect answer, $x = 6$. Her work is shown below in Figure 32.

- 3) Find where the tangent line crosses the x-axis. (Hint: the tangent line and the segment containing the center of the circle and the point of tangency meet at a 90° angle.)

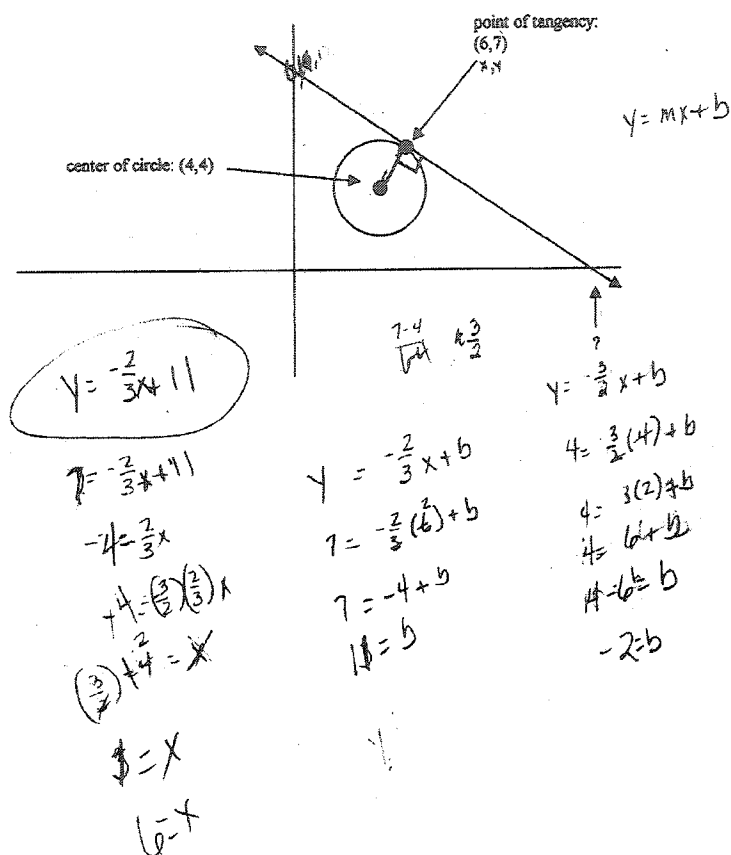

Figure 32: Helen's work on a line

She then graphed the line, $y = -\frac{2}{3}x + 11$, and discovered that $x = 6$ could not possibly be the right answer. She was then moved to go back and search for a suspected error. She found the error and reworked the problem again and corroborated the answer she had seen on the calculator.

On another occasion, she calculated the minimum point of a quadratic function algebraically and corroborated it with her calculator. In another instance, she solved a similar problem by first estimating the minimum point of a quadratic function on her calculator and then corroborated it algebraically. Seeking corroboration is undoubtedly an important part of having a useful Pre-Calculus mentality, and the calculator was clearly helping her develop this useful habit. But yet, throughout the semester, and especially in her exit interview, she maintained that the calculator was of little use to her in understanding and retaining skills and topics, even though the evidence shows that her calculator really did help her.

It may seem quite startling that a student could make so much use of a technology tool, and yet minimize its use when asked. It might seem that this was an isolated case of forgetfulness. However, although only one supersubject fit into this category, there were other examples of subjects (non-supersubjects) who were like Helen. They too, clearly benefited from the calculator, but yet, when questioned, seemed to downplay its significance. For example, several used their calculator to graphically verify a solution obtained by algebraic means, in some cases even detecting errors that led them to recheck their calculations and find error. But none of these used were recalled at a later time. Other students who underreported their calculator use utilized their calculator to estimate answers before writing an equation, and would then realize that their equation must be incorrect, because it would not yield a solution near the estimate. One non-

supersubject made what most math teachers would characterize as a brilliant use of his graphing calculator, but later did not recall this use when queried about his calculator use (See Appendix H).

Research Question 3b) Might a student maintain the calculator was not useful in learning a certain topic but in reality the calculator may have been used by the instructor in ways that facilitated student learning, but such usage was not reported by the student?

Helen, from the previous examples, clearly benefited from the instructor's calculator usage, and yet did not report it to be of consequence. Others also plainly benefited from calculator demonstrations, on the part of both the instructor and lab assistants, because they were later observed using the calculators in these ways to solve problems on homework and during in-person interviews with the researcher. Examples include using the calculator's graphing capabilities to corroborate algebraic solutions, using the calculator to estimate a maximum and/or minimum of a function, and using the calculator to simplify complex algebraic expressions. But other than Helen, those who were seen to benefit by such demonstrations recalled such instances and reported that they were indeed helpful.

Research Question 4) Do the students referred to in questions 2 and 3 have anything in common that would help researchers be aware that their perceptions may be suspect?

Of these research questions, only Question 2a was reported to have more than two subjects fit into that category, so the comments will be confined to this question.

Research Question 2a) Are there students who feel the calculator is helping them to understand class topics but in reality they do not understand the topic as clearly as they claim?

It was earlier reported that twelve students fell into this category. The majority of these twelve students could be seen to have the following things in common:

- 1) Most of the twelve rarely talked when using their calculators. When they did talk, they usually needed to stop using their calculators to carry on a conversation. (It was clear that many of the students, when using the calculator, were performing a memorized process. This will be further discussed in Chapter V.) If they did voluntarily “talk aloud,” it was usually after they had finished the problem. Interestingly, the more that these students engaged in conversation during problem solving sessions, the more likely they were to discern that their calculator was not as helpful as they had reported.
- 2) Nearly all of the twelve displayed a tendency to pick up the calculator at the start of a problem, whether or not they had developed a plan for using it. They

sometimes fondled it, as if looking for inspiration. Those who were likely to more correctly gauge the actual effectiveness of their calculator usage were much more apt to give some thought before picking up their calculator, usually having a plan in mind for their calculator prior to touching it.

- 3) Ten of the twelve seemed to be obsessed with formulas and procedures. They often seemed to get extremely nervous if they were unsure of a formula, even if I assured them that I would help them look it up or provide it if necessary. Often they were so relieved at getting an answer that they did not want to risk checking an answer in case it was wrong. Many were very good at recognizing a problem as one that they had previously solved with their calculator, but even in those cases where they solved the problems successfully, were often unable to justify their mathematical work and reasonings.
- 4) Most had very poor basic skills. To be sure, each subject was at a different skill level, but each displayed a serious lack of some basic skills. Many even mentioned that being able to perform basic math skills on their calculators was one of the reasons they believed the calculator helped them. But that does not necessarily mean that the graphing calculator proved more useful to the subjects with poor basic math skills. To illustrate how this can happen, observe the graph of $y = \frac{8}{x^2 + 4}$, shown below in Figure 33, as it was approximately rendered on the graphing calculator of one student mentioned above:

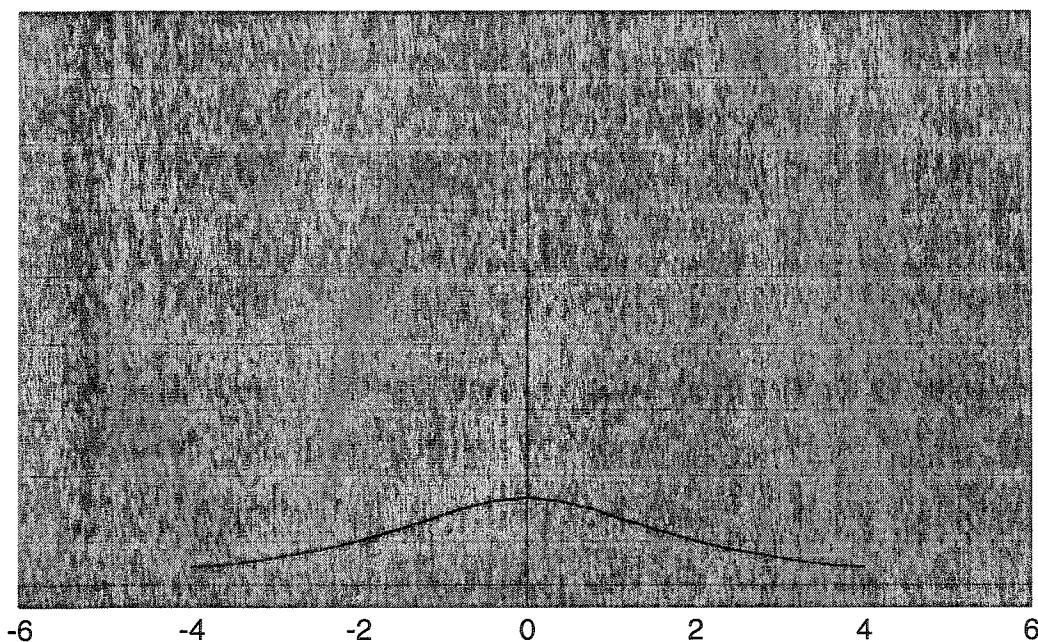

Figure 33: A student misunderstanding of calculator output

The graphical calculator is, of course, unable to show the entire graph, because it goes off into infinity both to the left and to the right. The student claimed that the graph “stopped” above $x = 4$ and below $x = -4$. I asked “so the function has no value for $x = 5$?” The student answered “Yes.” This student reported that the calculator was helping him, but clearly a lack of basic skills is causing the calculator in this instance to be not as useful as reported.

Conclusion

Most of the students saw their calculator use differently than the researcher did. A clear majority had the impression that the calculator was helping them, when in fact

their knowledge of the subject matter was often limited, or even poor. The graphing calculator gave them less help mastering class topics than they believed. Others were obviously mastering class material, but overstated the role the calculator had in helping them achieve this mastery. One student clearly benefited from using the calculator, but downplayed its usefulness. Only two of the subjects had perceptions that were valid the majority of the time. Many questions are raised by this majority. If their knowledge of the subject matter was so poor, how did they then conclude that it was better than it was? How did they manage to pass the class? How could they believe that they were mastering a subject when so much evidence shows that they were not? And how could they attribute this imagined mastery to a machine? Is there something about the subject matter, the graphing calculator, or something else that can explain this? Were the conclusions of the researcher justified? Would another investigator's conclusions be similar?

Chapter V

Discussion and Implications

There can be no doubt that mathematics education researchers (and mathematics teachers) want to know if graphing calculators are helping students learn mathematics. They want to know in what ways, and under what circumstances, they may either help or hinder student understanding and achievement. They want to know if some topics are better learned by students with the aid of such calculators, and if some topics may possibly be better taught without their use. They also want to know at what level of mathematics it may be appropriate to introduce (or perhaps limit) the use of such calculators. Many years have been spent studying these questions, and research will likely continue for the foreseeable future, especially since it is inevitable that these types of calculators will become increasingly sophisticated.

As they struggle to learn more about the effects of these graphical calculators, and whether or not they are helping their students learn mathematics, researchers, as well as teachers who view their own teaching as research, have in the past used student input to help them make this evaluation. The conclusions of many researchers that graphing calculators have had an overall positive effect on groups of mathematics students has in many cases stemmed at least in part from the analysis of student input (O'Callaghan, 1998 and Wilson and Krapfl, 1994). Positive student calculator perceptions, combined

with a rise in achievement, improved students' ability to analyze graphs, or an increase in other measures such as student attitudes toward mathematics, have led many researchers to conclude that the calculators should be given much of the credit for these improvements. In simpler terms, the researchers have in some cases concluded that student attitudes toward their calculators were generally to be trusted.

This research study has called such a conclusion into question. The majority of subjects here made claims about the usefulness of their calculators which were clearly not true. In the simplest example, which was a dominant theme of the study, a student would claim that the calculator helped him or her to learn a lot about a certain topic, but an interview with the student revealed that the student knew almost nothing about the topic, or possibly that his or her knowledge gain had little to do with the calculator. In other cases, the evidence unquestionably showed that a student had benefited from the use of a calculator, but the student denied its usefulness when questioned. A majority of students either overstated or understated the role their graphing calculator played.

The students in this research study overall had a very positive view of their graphing calculators and were generally successful in the course. A researcher who looked only at student attitudes toward their graphing calculators and student success in the course might mistakenly conclude that their beliefs about their graphing calculators were largely valid. Yet a close analysis of the evidence here shows that in many cases

positive student perceptions were misleading, and several negative and/or neutral perceptions were inaccurate as well. This presents a clear warning to researchers and teachers when using student input as a tool to gauge the effectiveness of graphical calculators in mathematics classrooms. More will be said about implications for teachers and researchers later. The fact that the subjects believed that they knew more about a mathematical topic than they really did is not the issue; it is how the calculator played a role in giving them this over-inflated view. How is it possible that students come to believe that their calculators are giving them more help than they actually are? We now look at three possible causes of these misperceptions.

Cause # 1: Poor Retention of Calculator Procedures

The first possible answer to the question of why students possessed overinflated views of how the calculator helped them is that in many cases students used the calculators in such a way that they had only a temporary effect, and when they interacted with the researcher, these calculator skills had been either partially or wholly forgotten. They may have seen these calculator procedures demonstrated by the instructors, the lab assistants, their peers, or may have discovered them on their own. They may also have seen these procedures described in their textbook. After practicing the procedures and skills, they were able, for a time, to solve problems with the help of their calculators. But this knowledge was in many cases only temporary. They did not retain what they

had practiced. So one possible explanation as to why they told the researcher that their calculators had helped them learn a certain topic may be simply that they were recalling situations in the past in which the calculator had helped them to solve such problems. During the interview process, however, in many cases, students had either forgotten or misapplied these procedures and skills. They may have felt, because of these experiences, that they were really learning something substantive because they were successful at using the calculator and solving problems assigned to them. But because their knowledge was fleeting, they were not able to exhibit these skills in later interviews with the researcher.

Here is an example. Janet had used the graphing capability of her calculator to solve a similar problem just ten days previous to the work shown below while in a one-on-one session. She evidently had not retained how to use this procedure, because she did not use the procedure that she had previously demonstrated, nor could she recall it when asked about it. Figure 34 shows her work:

2) Solve for x:

$$\frac{x}{1} + \frac{1}{x} = 4 \quad \left(\frac{x}{1}\right)$$

$$x^2 + 1 = 4x$$

$$x^2 - 4x + 1 = 0$$

$$(x - 3)(x + 1)$$

$$x = 3 \quad x = 1$$

$$\boxed{-3, +1}$$

$$1 + 1 = 4$$

Figure 34: Janet's work on a quadratic equation

As mentioned earlier, just ten days earlier, Janet had solved a similar equation with the help of her calculator in an interview session, but her solution seemed mechanical and superficial. So she was asked to try another one. As seen above, she got the wrong answer. I asked her if she could use her calculator to check this answer, and she replied that she wasn't sure how. She evidently had "forgotten" how the calculator could be used to solve equations such as these. Her confidence about how the calculator had helped her makes sense in that she at one time could use the correct calculator procedure. But now, just a few weeks later, she could not.

Another example of a subject displaying poor retention of calculator procedures comes from the work of Freda. Freda said on several occasions that her calculator was

helping her to learn about quadratic equations and quadratic functions and their graphs. It is quite likely that her confidence sprang from her ability to solve certain problems with the aid of her calculator. But yet Freda's knowledge of such procedures proved to be only temporary. In the following problem, shown in Figure 35, she was to find the minimum of a parabola.

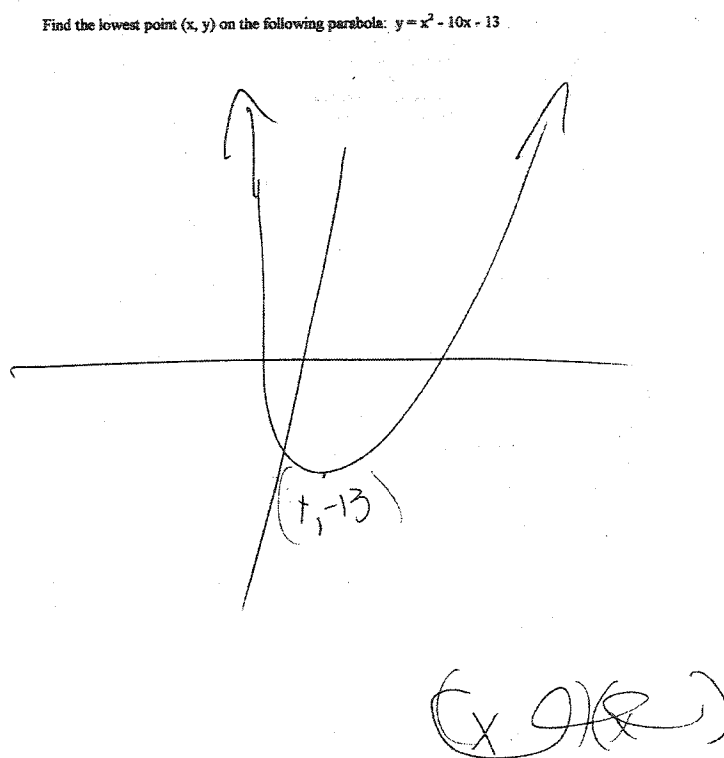
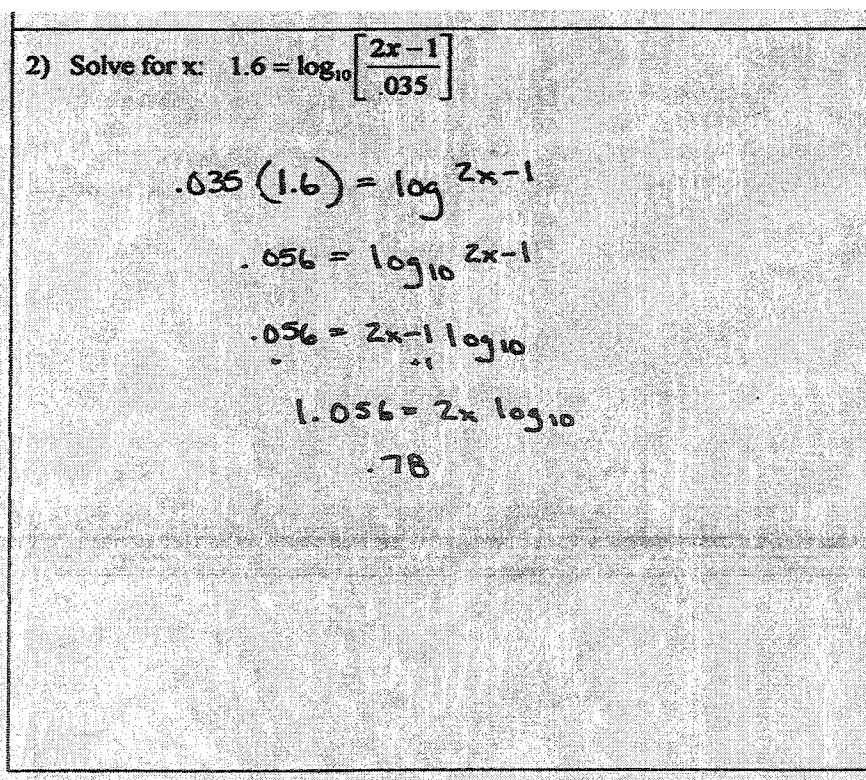

Figure 35: Freda's work on a minimization problem

Freda had previously demonstrated on a class assessment and during a one-on-one interview session how to find the minimum point of a parabola on her calculator. Certainly her claim that the calculator was helping her to learn about parabola could have come from these experiences. She had memorized the procedure, but had evidently

now forgotten it, because when asked to do it again, she could not. This “knowledge” was not permanent.

In the following example, the student, although able to solve a similar problem just a few weeks earlier utilizing the graphing feature of the calculator, provided clear evidence (shown below in Figure 36) that he no longer recalled the procedure. Yet just prior to his work on this problem he clearly stated his belief that the calculator was helping him learn about logarithmic functions and equations.



2) Solve for x: $1.6 = \log_{10} \left[\frac{2x-1}{.035} \right]$

$$.035 (1.6) = \log 2x-1$$
$$.056 = \log_{10} 2x-1$$
$$.056 = 2x-1 \log_{10}$$
$$1.056 = 2x \log_{10}$$
$$.78$$

Figure 36: An example of calculator non-retention

In this example below, a student who insisted his calculator was “very helpful” in learning about exponential equations as well as the role that logarithms play in solving them, performed the following work shown in Figure 37 just a few minutes after making that claim.

5) Solve for x: $1.1 \cdot 5^{x-1} = 6 \cdot [3^{(x+1)}]$

$$1.1 \cdot (5^{x-1}) = 6(3^{(x+1)})$$

$$\log 1.1 + \log 5^{x-1} = \log 6 + \log 3^{x+1}$$

$$\log 5(1.1) = x-1 = \log 3(6) = x+1$$

$$\log 5.5 = x-1 = \log 18 = x+1$$

$$.74036 = x-1 = 1.25527 = x+1$$

$$1.74036 = x = .25527 = x$$

$$\sqrt{1.99563} = x^2$$

$$x = 1.4127$$

Figure 37: Another example of calculator non-retention

He, like the others above, had shown the ability to use the calculator in solving similar equations just a week or so previously. His confidence could certainly have arisen from this experience. But this ability had been lost.

Below is another case in which a student could, for a time, solve logarithmic equations by using the graphing feature of the calculator. Just before working on the following problem, the student had spoken quite highly of the calculator in helping her understand and solve logarithmic equations. Likely her confidence may have come from her earlier ability to solve such problems with the aid of his calculator. But this knowledge had been forgotten. The work is shown in Figure 38.

7) Solve for x: $\log(x) + \log(x+15) = 2$

$\log(x)(x+15) = 2$

$x(x+15) = 10^2$

$x^2 + 15x = 100$

$x^2 + 15x - 100 = 0$

$a=1$
 $b=15$
 $c=100$

$$\frac{-15 \pm \sqrt{15^2 - 4(1)(100)}}{2(1)}$$

$$\frac{-15 \pm \sqrt{225 - 400}}{2}$$

$$\frac{-15 \pm \sqrt{-175}}{2}$$

$$\frac{-15 \pm 13.229}{2}$$

-8.3855
 -14.1145

Figure 38: Another example of calculator non-retention

In the above case, the student had even lost the understanding that logarithms of negative numbers are not defined and thus cannot be the solution of the above equation. Just a few weeks earlier, she had used the calculator in such a way that indicated that she understood this. This calculator knowledge was also therefore only temporary.

In the next example the student was given the exact same problem he had successfully solved with the aid of the calculator graphing feature just two weeks

earlier. The researcher suspected that his procedural knowledge was superficial, and so the identical problem was given again. He even said, "I think I solved this one before," but could not do so again. He evidently had memorized the procedure, but had now forgotten it. Note the work in Figure 39 below:

10) Find the intersection of these two lines $\frac{x}{3} + \frac{y}{4} = \frac{25}{8}$ and $\frac{x}{5} + \frac{y}{6} = \frac{39}{20}$

$$\frac{75-8x}{6}$$

$$\frac{y}{4} = \frac{25}{8} - \frac{x}{3}$$

$$\frac{y}{6} = \frac{39}{20} - \frac{x}{5}$$

$$\frac{y}{4} = \frac{25}{8} - \frac{x}{3}$$

$$\frac{y}{6} = \frac{39-4x}{20}$$

$$14.0625 + \frac{y}{4} = \frac{25}{8}$$

$$20y = 6(39-4x)$$

$$112.5 + 6y = 75$$

$$6y = 75 - 112.5$$

$$y = \frac{75 - 112.5}{6} = -6.25$$

$$\frac{x}{3} + \frac{75-8x}{6} = \frac{25}{8}$$

$$8x + 300 - 24x = 75$$

$$300 - 16x = 75$$

$$-300 \quad -300$$

$$\frac{-16x}{-16} = \frac{-225}{-16}$$

$$x = 14.0625$$

$$\frac{10y}{10} = \frac{117 - 12x}{10}$$

$$X = 14.0625$$

$$\frac{14.0625}{5} + \frac{y}{6} = \frac{39}{20}$$

$(14.0625, -6.25)$

$168.75 + 10y = 117$

$-5.175 \quad -5.175 \quad 10$

Figure 39: Another example of calculator non-retention

The following example is from a student who witnessed several demonstrations of how parabolas in the form $y = ax^2 + bx + c$ could be "shifted" on the coordinate system. The student seemed to be able to follow the demonstrations, and could even

replicate them very well, even to the point of creating quadratic equations that had only one solution. Graphing such equations results in graphs that touch the x-axis only once, and they would appear on the student's calculator screen as shown below in Figure 40.

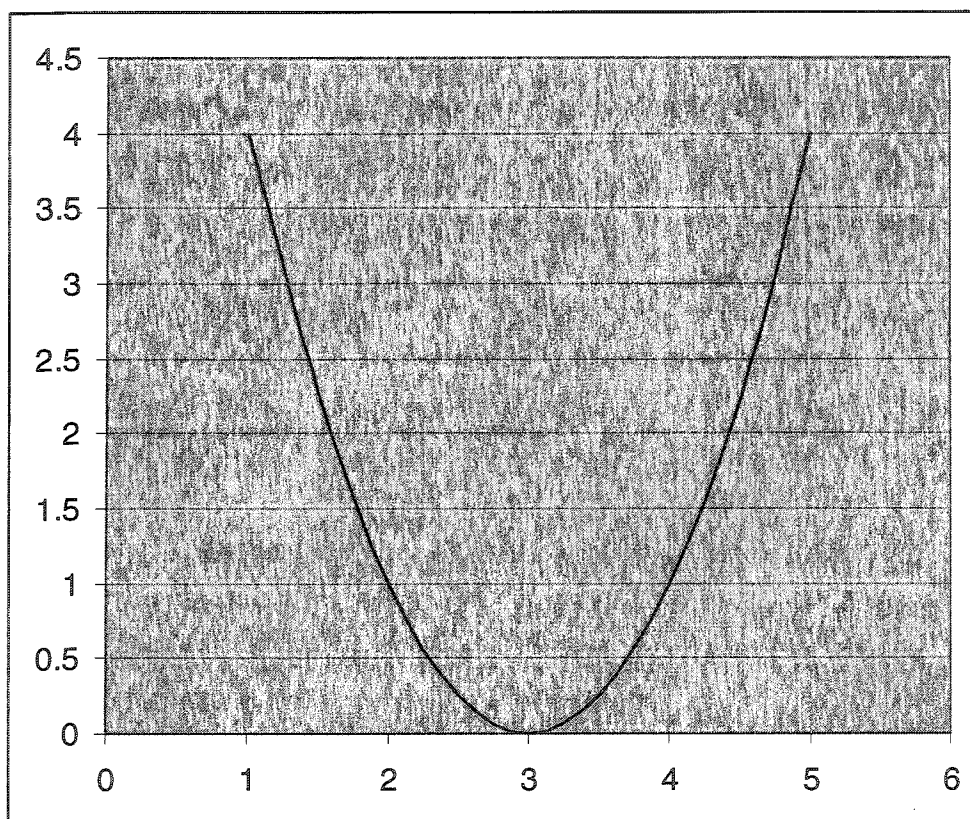

Figure 40: The graph of a parabola

He demonstrated good facility with such graphs, and even solved a similar problem to the one shown below several times. But after a few weeks, this knowledge vanished. Figure 41 shows his work on a problem in which he is trying to create a quadratic equation with only one solution.

2) Consider the quadratic equation $x^2 + 9 = bx$. For what value(s) of b does the equation have only one solution?

$$\frac{(x+3)(x-3)}{x} = \frac{bx}{x}$$

$x^2 + 9 = bx$
 $(x+3)(x-3)$

$\boxed{1/18}$

$x=3 \quad x=3$

Figure 41: Student work on a quadratic equation

Since he did not recall the calculator methods and procedures, even after some hints, he reverted to attempting to solve the problem algebraically, but failed. His comment that the graphing calculator had helped him to understand a lot about quadratic functions, made just two minutes before attempting this problem, was perhaps a recollection of many of the problems that he had solved previously with the aid of his calculator. But this knowledge was not retained.

The following eleven examples (Figures 42 through 52) are given without comment, except to say that they followed the same familiar pattern. First, the student is observed (either in person, in a lab session, or on an assessment) using a calculator

procedure, or a series of such procedures in order to solve a problem similar to the ones shown below. Then, the student not only reports that he or she has “learned” how to do such problems, but that the calculator should be given much of the credit for helping him or her. Then the student is observed being unable to solve a similar problem just a few days or weeks later.

5) Solve for x: $1 \cdot 5^{x-1} = 6 \cdot [2^{(x+1)}]$

$$1.1(5x-3) = 6(3x+3)$$

$$5.5x - 3.3 = 18x + 18$$

$$-3.3 = 12.5x + 18$$

$$-12.3 = 12.5x$$

$$x = -1$$

$$13185 (.699) = 6081 +$$

$$788 + (x+1)(.477)$$

$$9681 = 788 + .477x + .477$$

$$9.681 = 1.265 + .477x$$

$$8.416 = .477x$$

$$x = 17.65$$

Figure 42: Student work illustrating a forgotten calculator procedure

7) Solve for x: $\log(x) + \log(x+15) = 2$

$$x + x + 15 = 2$$

$$2x + 15 = 2$$

$$2x = 2 - 15$$

$$2x = -13$$

$$\frac{2x}{2} = \frac{-13}{2}$$

$$x = -6.5$$

Figure 43: Student work illustrating a forgotten calculator procedure

5) Solve for x: $1.1 \cdot 5^{x-1} = 6 \cdot [3^{(x+1)}]$

$$5.5^{x-1} = 18^{x+1}$$

$$\log 5.5^{x-1} = \log 18^{x+1}$$

$$x-1 \log 5.5 = x+1 \log 18$$

$$x-1(.74036) = x+1(1.25527)$$

$$x-.74036 = x+1.25527$$

Figure 44: Student work illustrating a forgotten calculator procedure

7) Solve for x: $\log(x) + \log(x+15) = 2$

$$\log(x(x+15)) = 2$$

$$\log(x^2 + 15x) = 2$$

$$\log x^2 + \log 15x = 2$$

$$2 \log x + \log 15x = 2$$

Figure 45: Student work illustrating a forgotten calculator procedure

7) Solve for x: $\log(x) + \log(x+15) = 2$ $x = 5.78125$

$$10^2 + 10^2 = x + x + 15$$

$$200 = x + x + 15$$

$$185 = 2x$$

$$92.5 = x$$

1.3
1.7
1.66

46.25
23.125
1.966142

$$\log(5.78125) + \log(20.78125)$$

$$.76202 + 1.3176 = 2$$

$$2.07 \approx 2$$

Figure 46: Student work illustrating a forgotten calculator procedure

2) $\log[x+11] + \log[x] = 2.4$ (Give the answer(s) to three decimal places.)

$\log[x+11] + \log[x] = 2.4$

$\log x + 1.0414 + \log x = 2.4$ (log)

$\log x + 1.0414 + \log x = .3802$

$2 \log x + 1.0414 = .3802$

$-1.0414 = .3802$

-1.0414

$\frac{2 \log x}{2} = \frac{-.6612}{2}$

$\frac{\log x}{\log} = \frac{-.3306}{\log}$

$x = \frac{-.3306}{\log}$

Dist. Property
log 11
log x
log x

Figure 47: Student work illustrating a forgotten calculator procedure

2) Solve for x : $1.6 = \log_{10} \left[\frac{2x-1}{.035} \right]$ I don't even know where to start!

Figure 48: Student work illustrating a forgotten calculator procedure

2) $\log [x+11] + \log [x] = 2.4$ (Give the answer(s) to three decimal places.)

$x+11 + x = 2.4$ $\log [4.3+11] = 1.185$

$2x+11 = 2.4$ $\log [4.3] = 0.6335$

$2x = -8.6$

$x = -4.3$

Figure 49: Student work illustrating a forgotten calculator procedure

The perimeter of a rectangle is 20 inches. If its diagonal is 8 inches, find the dimensions of the rectangle.

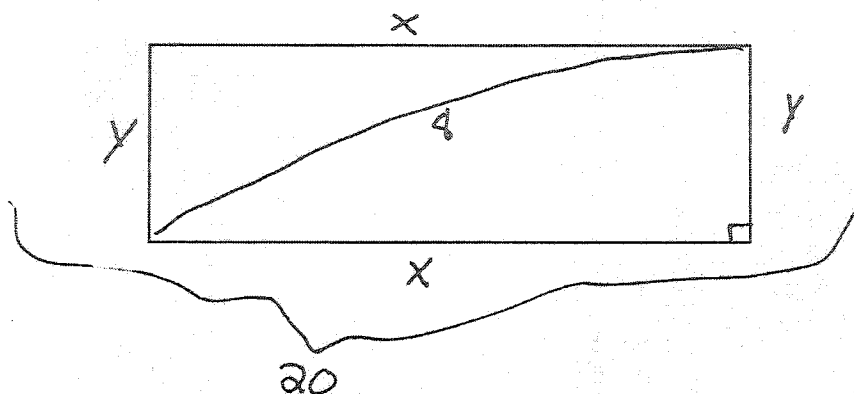

$$x + y + x + y = 20$$

$$2x + 2y = 20$$

$$x + y = 10$$

$$y = -x + 10$$

$$x^2 + y^2 = 8^2$$

$$y^2 = 8^2 - x^2$$

$$\sqrt{y^2} = \sqrt{64 - x^2}$$

$$y = 8 - x$$

Figure 50: Student work illustrating a forgotten calculator procedure

$$\textcircled{160} \sqrt{2x-1} - \sqrt{x+11} = 1$$

$$(2x-1) - (x+11) = 1$$

$$x + 10 = 1$$

$$x = -9$$

Figure 51: Student work illustrating a forgotten calculator procedure

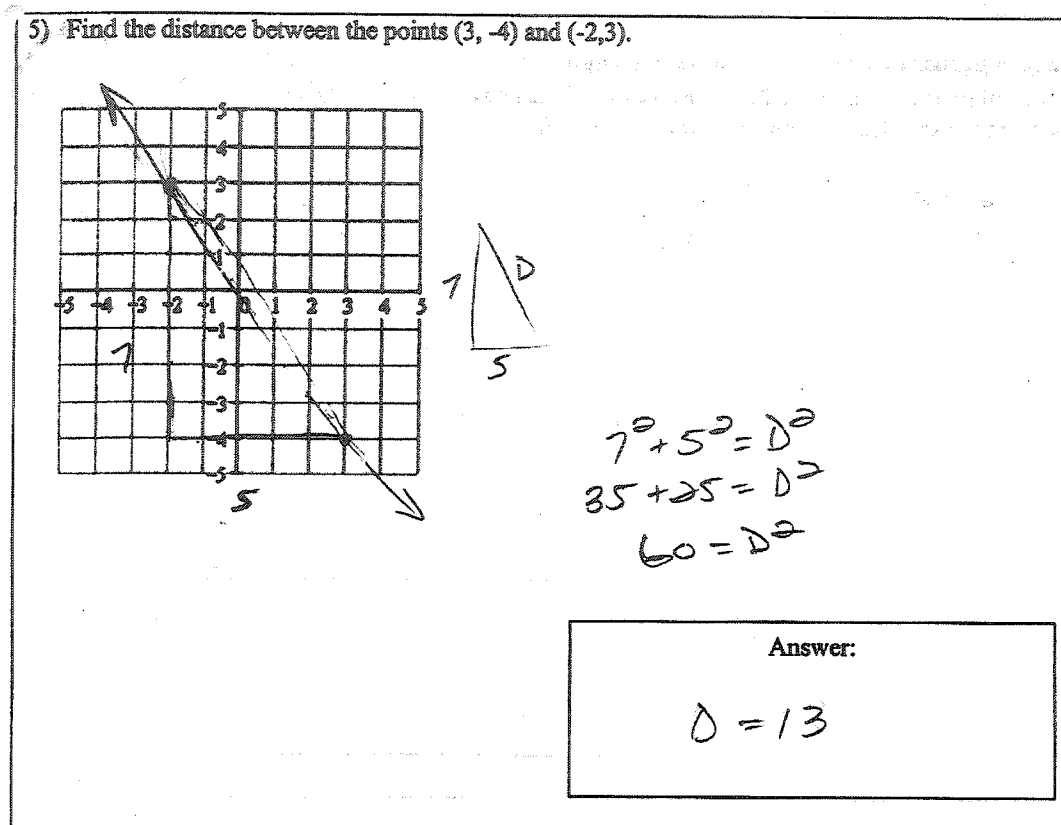

Figure 52: Student work illustrating a forgotten calculator procedure

Each of the students above used his or her calculators in ways in which the instructor and the lab assistants had demonstrated to them. The lab assistants not only demonstrated a multitude of calculator skills, but made sure that the students practiced these skills and procedures during lab sessions. Such practice with the students included making sure that students could do simple math on the graphing calculators, such as noting the importance of using parentheses when performing multiplication and division of complex expressions. Several students also used calculator procedures that they had

seen in the textbook. The instructors would certainly approve of the ways they used the calculators. It might be said that they were doing what they were supposed to be doing. Each student had previously solved similar problems in ways which were “appropriate.” But yet the procedures were not retained for any length of time. In all of the above cases, after the students failed to solve the problem, I asked each of them if they knew of any way to use the calculator to solve these problems. I gave plenty of hints and allowed plenty of time to help them search their memory. Some students had some vague ideas about what course to take, but in all of the cases could not give a productive way to use the calculator to solve the problem. All of these students felt that their calculators were helping them, and may have been partly moved to make this claim because the calculator had helped them to temporarily solve some problems, and gave them a feeling of success. Their statements to the researcher to the effect that their calculators were helping them, when in fact, they were gaining little permanent knowledge, may therefore be partially explained in this light.

Cause # 2: Naïve Assessments

Another reason why these subjects may have overstated the role their calculators had in helping them to learn is one which is familiar to many in the mathematics education community. This second possible explanation may have to do with the type of assessments used in the classes. The assessments were in many cases naïve, or poorly

designed, in that a passing grade on an assessment may not have necessarily meant that the student had a good understanding of the topics covered on that assessment. In many cases, which will be described below, students passed assessments with the use of a graphing calculator, using it in ways that may have led the instructor (and the student) to presume that the student had greater understanding of a topic than really existed. In reality, their knowledge may have been superficial and limited, but the calculator helped them pass an assessment which created the impression that they know more than they actually did.

Students may therefore have incorrectly concluded that they had a good understanding of a topic because the calculator had helped them successfully complete such assessments. Based on the experience of passing an assessment, they then reported that the calculator has helped them to understand a topic which they really did not. When the students reported that they understood a topic, often they explicitly referred to a previous class assessment which they had passed that measured their knowledge of this particular topic. Some even produced these quizzes and exams as proof of their mastery of certain class topics. Other times it was clear that they were referring to these assessments, because subsequent questioning revealed that they drew their conclusion from classroom assessments.

Of course, this idea of naïve assessments would certainly include those examples from the previous section in which students remembered a procedure long enough to pass an assessment, only to forget the procedure. However, even though the instructor did not intend the students to forget the procedures so quickly, all of the students in the above examples used the calculator in ways that were sanctioned and encouraged by the instructor, the lab assistants, and the textbook. In the following cases, they used the calculator in ways that may not have been intended by the instructor, but these uses still enabled them to pass the assessment while having very little, if any, knowledge of the topics assessed. To put it into the vernacular of the math classroom, they really didn't know what was going on. The following examples show that some of the assessments were extraordinarily naïve, in that students passed them even with a profound lack of topical knowledge, not just because they forgot a calculator procedure.

Consider some examples. Recall the case of Nancy from Chapter IV. Nancy reported that the calculator had helped her understand the concept of lines, but yet she demonstrated a profound lack of knowledge of the coordinate system, upon which lines are customarily drawn. Here again in Figure 53 is a copy of her work on a particular problem dealing with lines:

- 1) Find where the tangent line crosses the x-axis. Hint: the line segment containing the radius and the tangent line meet at a 90° angle.

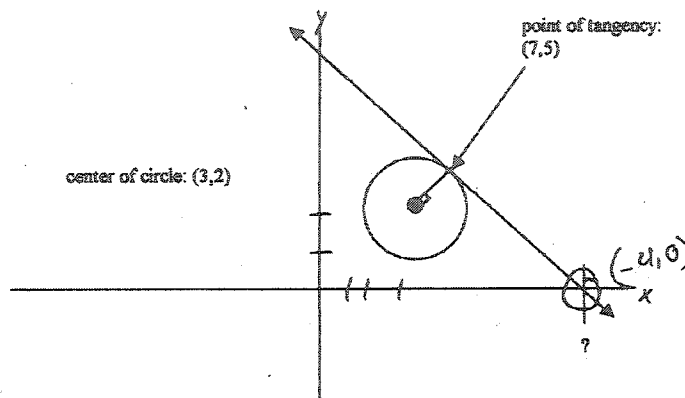

error

$$m = \frac{5-2}{7-3} = \frac{3}{4} = \frac{3}{4} \text{ perp.}$$
~~$$y - 5 = \frac{3}{4}(x - 7)$$

$$y - 5 = \frac{3}{4}x - \frac{21}{4} + \frac{15}{4}$$

$$y = \frac{3}{4}x - \frac{20}{4}$$

$$0 = \frac{3}{4}x - \frac{20}{4}$$

$$\frac{20}{4} = \frac{3}{4}x$$

$$5 = \frac{3}{4}x$$

$$-4 = x$$~~

$$(-4, 0)$$

Figure 53: Nancy's work on lines

Nancy here is unable to recognize that the point of intersection cannot possibly have a negative x value. Even after she was questioned about this, she continued to insist that she had the right answer. How is it possible that despite evidence to the contrary, she claimed a good knowledge of lines and claimed that the calculator had

helped her gain such knowledge? Part of the answer may be that just a week or so before she worked on the problem pictured above, she had passed a test dealing primarily with lines. Further questioning revealed that Nancy remembered this assessment and specifically felt her calculator helped her to pass this assessment. Her statement of confidence in her understanding of lines could certainly have come from the experience of passing this assessment.

Analysis of this test along with a conversation with Nancy revealed that she passed the assessment primarily because the calculator helped her to answer the questions even though she had limited understanding of lines. Two of the test items asked the student to graph lines, which required little more than the entry of the formula into the calculator, and copying the output onto the test sheet. Another item asked the student to determine if a certain point was, or was not, on a certain line. Nancy (as well as others) was able to do this through a memorized procedure. Yet another test item involved finding the equation of a line given two points. Nancy solved this problem correctly on the assessment, again, through a rote procedure which she demonstrated in an interview session. Each of these test items were practiced very carefully before the test, and each of these items could easily be memorized by a determined student, even one lacking a substantive knowledge of the topic. This certainly appears to be the case with Nancy. She had passed an assessment on lines without really knowing much about

them. The assessment was naïve. Her discussions with the researcher revealed a very weak understanding of this topic.

This idea of naïve assessments could also explain the overconfidence of other students. The example of Rita, who passed exactly the same assessment that Nancy did, illustrates this in a similar way. Recall Rita's incorrect analysis of the following problem, in which she claimed that a point on the axis had a negative value when it was clearly positive. It is shown below in Figure 54:

- 3) Find where the tangent line crosses the x-axis. (Hint: the tangent line and the segment containing the center of the circle and the point of tangency meet at a 90° angle.)

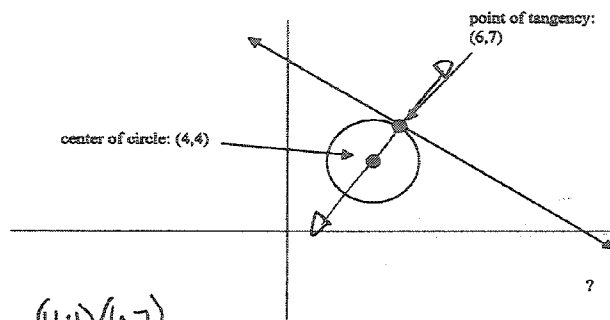

$$\begin{aligned}
 & (4,4)(6,7) \\
 m &= \frac{7-4}{6-4} \\
 &= \frac{3}{2} = \frac{2}{3} \\
 & 3(y-7) = \frac{2}{3}(x-6) \\
 & 3y-21 = -2x+12 \\
 & 3y = -2x-9 \\
 & y = \frac{-2}{3}x - 3 \\
 & 0 = \frac{-2}{3}x - 3 \\
 & -\frac{3}{2} \cdot 3 = \frac{-2}{3}x - \frac{3}{2} \\
 & x = \frac{-9}{2}, -4\frac{1}{2}
 \end{aligned}$$

Figure 54: Rita's work on lines

Rita, despite the above example, was almost lyrical when talking about her calculator helping her understand lines. When she reported that the calculator helped her, could it be that she was referring to the assessments, and not to her understanding? She, too, had passed the same assessment that Nancy had, using methods similar to Nancy's, even offering her assessment to the researcher as proof that she was learning

about lines. But in reality her knowledge of lines was quite limited. Unfortunately, the assessment actually hid, rather than revealed, Rita's misconceptions and misunderstandings. It was naïve.

Another example of naïve assessment contributing to a student overstating the usefulness of the calculator is the situation with Michele. Naïve assessments could certainly explain her overconfidence in being able to solve equations. She claimed on several occasions that her calculator was quite helpful in helping her solve and check equations. Prior to the example that will be shown below, two assessments (which she passed) included equations which she was able to input into her calculator and solve using the calculator's built-in solve feature the "solve" button. (The instructors did not intend for the students to use the calculator in this way, and subsequent discussion with them revealed that they were not aware that the students were doing this.) She tried to input the equation in the following example into her calculator so that it would solve it for her, but she was unable to input it correctly. This particular equation did not follow the familiar pattern she had expected, such as $2x + 1 = 3x - 4$. Her work is shown below in Figure 55, attempting to solve an equation.

4) Solve for y. $\frac{4}{y} + 5 = \frac{5}{27}$

~~$(\frac{4}{y} + 5) = \frac{5}{27}$~~

$$\frac{5}{27} + 5 = \frac{4}{y}$$

$$\left(\frac{5}{27} + 5\right)y = 4$$

$$y = \frac{4}{\left(\frac{5}{27} + 5\right)}$$

$$\frac{5}{27} + \frac{5}{1} = \frac{10}{27}$$

Figure 55: Michele's work on a simple equation

At this point she gave up, and said that she could not continue further. The subsequent conversation with Michele revealed not only that her equation solving skills were extremely weak, but that her basic skills, such as fractional arithmetic, were also poor. Her claims that the calculator had helped her understand how to solve equations quite possibly originated in the fact that her assessments so far had led her to believe that she was learning more about solving equations than she actually was. The calculator in this case was having two harmful effects not reported by the student: (1) it was helping to hide, rather than reveal, Michele's poor skill level at solving equations and (2) it was also preventing Michele (as well as her instructor) from coming to grips with the fact that her basic math skills should be remediated.

researcher clearly demonstrated that his understanding of lines was poor. In the above example, he was unable to even check if the two data points that he was given were on the line he had found. A careful look, for example, shows that he has put the data points into the wrong places in his table. He shows a lot of confusion about linear relationships. Yet a naïve assessment found that he knew much more than he did, and this may have been the basis for the claims he made to the researcher about the role of his calculator

Linda on several occasions had mentioned that her calculator had been useful in helping her to understand logarithms. She had passed an assessment dealing with logarithms, just a week or so before doing the work shown here in Figure 57.

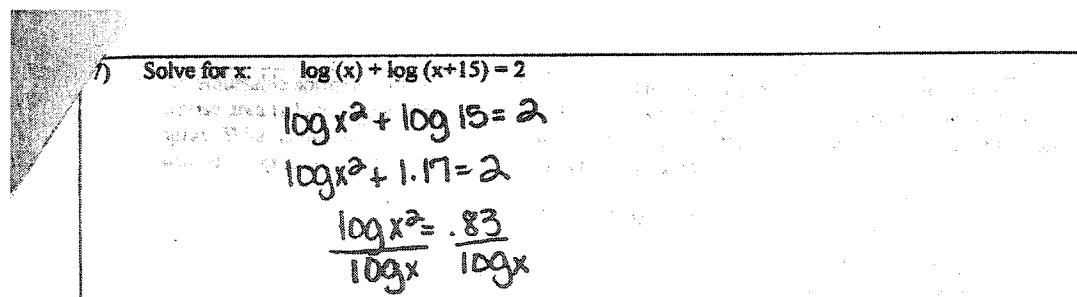

7) Solve for x: $\log(x) + \log(x+15) = 2$

$$\log x^2 + \log 15 = 2$$

$$\log x^2 + 1.17 = 2$$

$$\frac{\log x^2}{\log x} = \frac{.83}{\log x}$$

Figure 57: Linda's work on a logarithm problem

This example is clear evidence that her knowledge of logarithms and logarithmic functions is much less pronounced than she claimed. In a similar way to the previous students, much of the justification for her belief that the calculator was helping her

understand logarithms was an exam, which she offered as evidence that she was learning logarithms. Analysis of the assessment revealed that she found most of the answers using her calculator to perform calculation involving logarithm laws that she did not understand and graphing functions that she could not interpret. She passed the exam, but she knew less that the assessment measured.

Perhaps the most powerful argument for the probability that naïve assessments contributed to a student overstating his or her knowledge of a topic was the case of Cathy. Recall that she was able to solve a problem taken right off one of the assessments by following a procedure that she had memorized. Figure 58 again shows her work:

3) In a pond there are 1000 mosquitoes at the beginning of an experiment. After 2 days, there are 2000 mosquitoes. How many mosquitoes will there be after 4 days? Assume the rate of growth is the same for all 4 days.

$$A = Pe^{rt}$$

$$2000 = 1000 (e^{0.34657})^2$$

$$3,999 \text{ mosq.} / 2 = (2.71828)^{rt}$$

$$LN = \frac{0.693147}{2} = 0.34657 = R$$

$$1000 (e^{0.34657})^4$$

$$1000 (2.71828)^{1.38628}$$

$$1000 (10.48576)$$

$$10,485.76$$

Figure 58: Cathy's work on an exponential growth problem

Recall that Cathy had stated “What is that e thing anyway? 10?” after she had solved this problem. Note that she had written a correct approximation of e , namely 2.72828, but she did not know that what she had written was actually an approximation for the value of e . She had learned how to solve the problem through a memorized procedure, and yet she did not understand the fundamental idea of the problem, which is the application of the number e . She on several occasions claimed that the calculator helped her to understand exponential equations. Clearly, just as in the case of the other students, at least part of her confidence no doubt sprang from the fact that she had passed an assessment which led her to conclude that her knowledge was greater than was actually the case.

Other students fell into this pattern as well. Several others, whose knowledge of certain topics was very limited, spoke highly of their calculators, and as evidence, gave either reports of their assessments, or the actual assessments themselves. Clearly, one of the primary reasons why students overestimated the help their calculator gave them was that naïve assessments allowed them to pass assessments when they had limited knowledge of the topics in question.

Cause # 3: High-School Experiences

There is a third intriguing possibility as to why many students believed that their calculators were helping them more than actually were, while simultaneously giving evidence that their knowledge was less than they claimed. Many students, especially those who were freshman, during our one-on-one conversations spoke quite glowingly of their high school mathematics experience. They especially spoke quite highly of how their graphing calculators helped them “get through” upper level high school mathematics courses. Some had even passed a placement test that put them in this Pre-Calculus class, and mentioned that the graphing calculator was crucial in helping them do this. The overconfidence they showed in their graphing calculators could certainly have arisen from these experiences. Given that they had experienced such successes in the past, it seems quite reasonable that when asked if their calculators had helped them, that they would answer in the affirmative. As to the fact that many of them had limited knowledge of topics which they claimed to have mastered, this inconsistency may be partially explained if in the past they had the experience of passing naïve assessments such as the kind earlier described. Another explanation could be that their math skills may have gotten a bit rusty, and they as freshman may have not yet had to come to grips with this. They may have reasoned that the undeniable experience of a successful high school math experience must necessarily mean that they will have success now.

Implications for Researchers

Had this researcher relied only on the subject's perceptions, not having the opportunity to observe the students more closely, he would almost certainly have come to some incorrect and/or misleading conclusions. For example, imagine if a survey instrument had been given to these subjects at the end of the semester asking them whether or not they believed that their graphing calculator had helped them to learn certain mathematics concepts and skills, and the researcher had no data other than student achievement and/or student grades from which to draw conclusions. The majority of these subjects would likely have reported that the calculator helped them, and the fact that they passed the class may have led the researcher to conclude that their conclusions were on the whole valid. Others would likely have dismissed the role of the calculator as a help, and the researcher may have concluded that if the student passed the class, the calculator did not play a major role in helping them, and that some other factor or factors were primarily responsible. The data from this study suggest that these conclusions would be wrong in the majority of cases. Is it conceivable that some research studies which have relied primarily on student achievement and student attitude toward their calculators have reached at least partly wrong conclusions?

Take the example again of Rita. Looking only at Rita's assessments (she passed the class) and her positive attitude toward her calculator might lead a researcher to

conclude that her calculator was helping her much more than was actually the case. For example, recall the work below, shown in Figure 59, which clearly shows that Rita's knowledge of lines and of the coordinate system is very poor:

- 1) Find where the tangent line crosses the x-axis. Hint: the line segment containing the radius and the tangent line meet at a 90° angle.

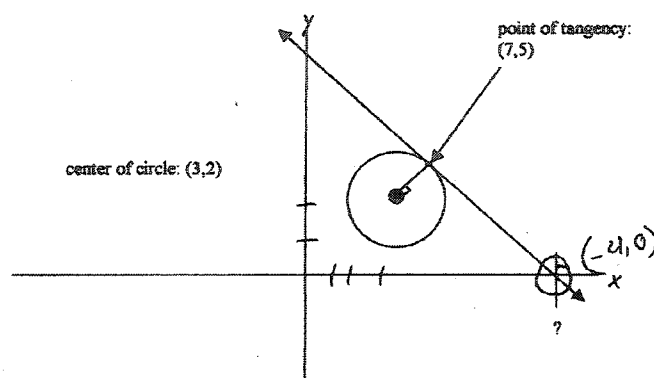

$$m = \frac{5-2}{7-3} = \frac{3}{4} = \left(-\frac{4}{3}\right)^{\text{perp.}}$$

~~$$y - 5 = \frac{3}{4}(x - 7)$$~~

~~$$y - 5 = -\frac{4}{3}x + \frac{21}{3} + \frac{15}{3}$$~~

~~$$y = -\frac{4}{3}x + \frac{26}{3}$$~~

~~$$0 = -\frac{4}{3}x + \frac{26}{3}$$~~

~~$$\frac{4}{3}x = \frac{26}{3} \quad (-4,0)$$~~

~~$$-4 = x$$~~

Figure 59: Rita's work on lines

Her statements about her calculator, and the fact that she passed the class may have hidden the real situation from someone using only student input and the result of class evaluation and/or class grades. This is not to imply that Rita's perceptions about her calculator could not be useful. In fact, her perceptions were quite useful, as they clearly point out that the assessment practices and calculator procedures used in the class should be looked at more closely.

Research that looks primarily at student input and achievement, without closer contact with students, may thus not reveal the true picture of graphing calculator usage. Remember also the examples of students who really did benefit from the calculator, but did not report those uses as beneficial. The uses of the calculator which truly benefited students may be overlooked and other aspects of the classroom environment might mistakenly get the credit that belongs to the graphing calculators. Researchers may do well to look closer and be more skeptical of student attitudes toward their calculators. The data from this study suggest that student input is extremely complex and very difficult to interpret. Claims about the effectiveness of calculators based only on student achievement and student attitudes toward their calculators may therefore be suspect. (Note: Although the researcher is critical of the assessments used in these classes, it may be unfair to suggest that previous research studies may be flawed because of naïve assessments, given that in many such studies the assessments are not available for

review. Still, the possibility should be admitted, and the data here suggest that subsequent research studies about the effectiveness of graphing calculators should include a thorough dissection and discussion of assessment instruments.)

Researchers also may need to be careful not to be content with surveys or questions that oversimplify the role of the calculator. A question such as “Did the calculator help you understand such and such” may not be sufficient to bring out all of the subtleties that are inherent in a tool of such complexity. Questions such as this were asked by this researcher, who quickly realized that the student’s calculator usage is almost always much more complex than either helping or not helping. Also, seeing the graphing calculator as either wholly helpful or wholly harmful to a particular student is a very naïve view of a tool with so much potential for both helping a student and potentially impairing him or her. Clearly, some students can be helped by a graphing calculator on certain topics, while on other topics the calculator seemingly provides little if any help. Ironically, the exact opposite situation may exist in another student, even in the exact same class.

Remember also the difficulty encountered here in determining what students mean when they gave a simple answer such as the calculator “helped.” Helped them to do what? Pass a test? Complete an assignment? Explore a difficult concept? Investigate a hypothesis created by the students? All or none of the above? When students report

that the calculator helped them, the researcher may envision the students doing all sorts of things which the students may not necessarily have done. Instead of investigating an interesting hypothesis by using the calculator as a tool for considering multiple possibilities, students may have simply used it to add two numbers together.

What this may mean is that student input may be much more useful, and the results of the student input would provide richer data if such data are combined with a closer look at student usage and perceptions. In the case of this study, just a few minutes spent with a student illuminated their perceptions by magnitudes. Imagine what would have been missed in even this small study if the researcher had simply given a survey instrument. Student interaction with their calculators is likely much too complex to dissect with, for example, the use of a simple survey or questionnaire. The data also suggest that the results of achievement tests would prove to be misleading in either confirming or denying what students are claiming. It is difficult to imagine that something useful would not be gained by adding student interviews to the results of a survey or questionnaire. If time is the issue, this researcher would rather save the time and expense of creating a survey or questionnaire instrument and instead spend that saved time on direct interaction with the students. This researcher cannot imagine what a survey or questionnaire might have revealed that the one-one-one sessions with the students did not.

Implications for Teachers

Teachers who use graphing calculators in their classrooms undoubtedly want the calculators to have a positive impact on student learning; that is the reason they bring them into their classrooms. Teachers also undoubtedly wish their students to enjoy the experience of using graphing calculators, and want them to feel that their use is positive. However, a fundamental principle clearly seen in this study is that positive student reaction should not always be interpreted as meaning the calculators were therefore useful in helping students learn and retain the mathematics we wish them too. Also, negative or neutral reaction should also not be seen as a sign that the calculators are not helping. Recall the case of Helen who was observed using the calculator in several creative and imaginative ways to help her gain mastery over several course topics, but who later denied that her calculator was helping her much. A healthy skepticism should be used when analyzing and interpreting student input.

Also, it would be a mistake for a teacher to conclude that even if it is admitted that graphing calculators have an overall positive benefit on groups of students that this necessarily means that each student therefore gains at least some benefit. This research suggests that negative calculator impacts may be more prevalent than teachers wish to believe. It is also important to recognize that a student who benefits from a graphing calculator on one day or on one topic may have a negative experience on the next day or

on the subsequent topic. This is especially true as a teacher gains greater insight into actual student calculator usage, not just that which the teacher demonstrates or sanctions. A teacher should consider the possibility that the time needed to gain these insights may be well worth it.

Teachers may also benefit by considering that students who use graphing calculators in ways that may turn out to be harmful and counterproductive may have a tendency to be reluctant to speak about and discuss these uses. In this research study, the students who were found to be using the graphing calculators in ways that were healthy and productive were more than willing to discuss these uses, and were willing to provide a clear rationale for their use. Ironically, it was these very students who were most likely to admit that sometimes they were unsure if the calculator was going to help. Students who were found to have a distorted view of the way their calculators were helping them, as well as those who were using the calculators “inappropriately” were much less likely to provide a rationale for using their calculators, and were less willing to engage in conversation with the researcher while they were using the calculators. “Inappropriately” can be defined here partially as knowingly using the calculators in ways that they knew were designed only to get an answer to a problem or to pass an assessment, while clearly recognizing that there did not exist a corresponding increase in their understanding of class topics. If a teacher is looking for a way to determine which students may be better trusted when making claims about their calculators, a good

start may be to observe which students are willing openly to talk about their use.

Another clue may be to notice those who clearly can explain why they want to use their calculators **before** they use them. Students who are quietest while utilizing their calculators may be uncomfortable because they are the ones most unsure whether what they are doing is beneficial.

Student retention of graphing calculator skills and procedures was a major issue for many of the students in this research study. The problem of student retention is not new. Teachers worry all the time if and for how long their students retain the knowledge gained in their classes. They also wonder if such knowledge is “transferred” by students to other classes, as well as to life outside the classroom. Usually teachers assume (or hope) that students will retain such knowledge for a long period of time, or even indefinitely. But in the case of many students in the research study, the mathematical knowledge they gained with the help of a calculator was retained for a period of only weeks, or in some cases, only days. Teachers using graphing calculators in their classrooms may need to consider the possibility that some of the calculator techniques we customarily ask students to perform may be of limited use, as students may retain such procedures for an extremely limited time, if at all. Is it possible that the very ways in which we want students to use calculators may be ways that for many students may not lead to long-term retention? Could the calculators themselves contribute to the retention problem?

For what reason do we want students to learn these calculator techniques? Is it so that they can repeat the techniques when we want them to? If not, is it so that we may illuminate a larger idea or concept? If that is true, is it OK if they forget the calculator procedure once they understand the concept in question? If we want students to use the calculator for exploration and investigation, do we give them the latitude and time they need to improve these (learned) skills? Recall the case of Steve and Kyle, who were seen to be making mathematical progress with the help of their calculators, even though they sometimes exhibited confusion and misconceptions. Creative and imaginative use of their calculators was clearly helping them explore class topics, even though they were often slow in finding the right answer. Do our assessments emphasize exploration, investigation and analysis, or is that reserved only for classwork and homework? Do we ever consider times when we as teachers may not want to use the calculator, recognizing times when it may possibly prove counterproductive? Can we even imagine that this may be a possibility?

Teachers may have to ask themselves some even harder questions. For example, if a student can graph a quadratic function, and find where the roots are by noting where the curve crosses the x-axis, is that how the student is to solve quadratic equations in the future? Or is the reason for having the student do this to illustrate the idea that a quadratic equation can have at most two solutions, and sometimes one or even none?

Do they need to know both the graphical way of solving equations, as well as others such as the algebraic way? Do we care if a student can graph a function on a calculator but not by hand? Does it matter? If a student can pass one of our assessments with a calculator but cannot pass the same assessment with or without a calculator a month from now, are we doing a good job? Does being able to graph and solve a system of equations on the graphing calculator mean that the student understands the systems concept? Is it acceptable for students in high school and /or college to use the calculator for fractional arithmetic, if they can't do fractions by hand? Do we consider the possibility that some students who are now in our class have gotten this far in mathematics by using their calculators in inappropriate ways, and that if we do not figure this out and intervene, they may have little choice but to continue using it in these inappropriate ways?

It might never cross our mind that students are willing to abuse the calculator just to pass our class, but perhaps it should. If such an idea does not occur to us, we may be blind to students who see the calculator as just another tool to pass another math class without really knowing what is going on. This research study involved at least a dozen students who saw the calculator in precisely this light. Shown just below in Figure 60 is the work of a student who, in the opinion of this researcher, should never have passed the class, but because of her clever use of the graphing calculator, managed to fool the instructor on multiple assessments. (Bear in mind as you look at this work that after the

student completed the work below, the researcher several times directly told the student that there were errors in her work, even pointing out in which step the errors were. In spite of this, the subject was not able to locate errors and correct the errors, even though a 9th or 10th grade high school student would be expected to easily do so.)

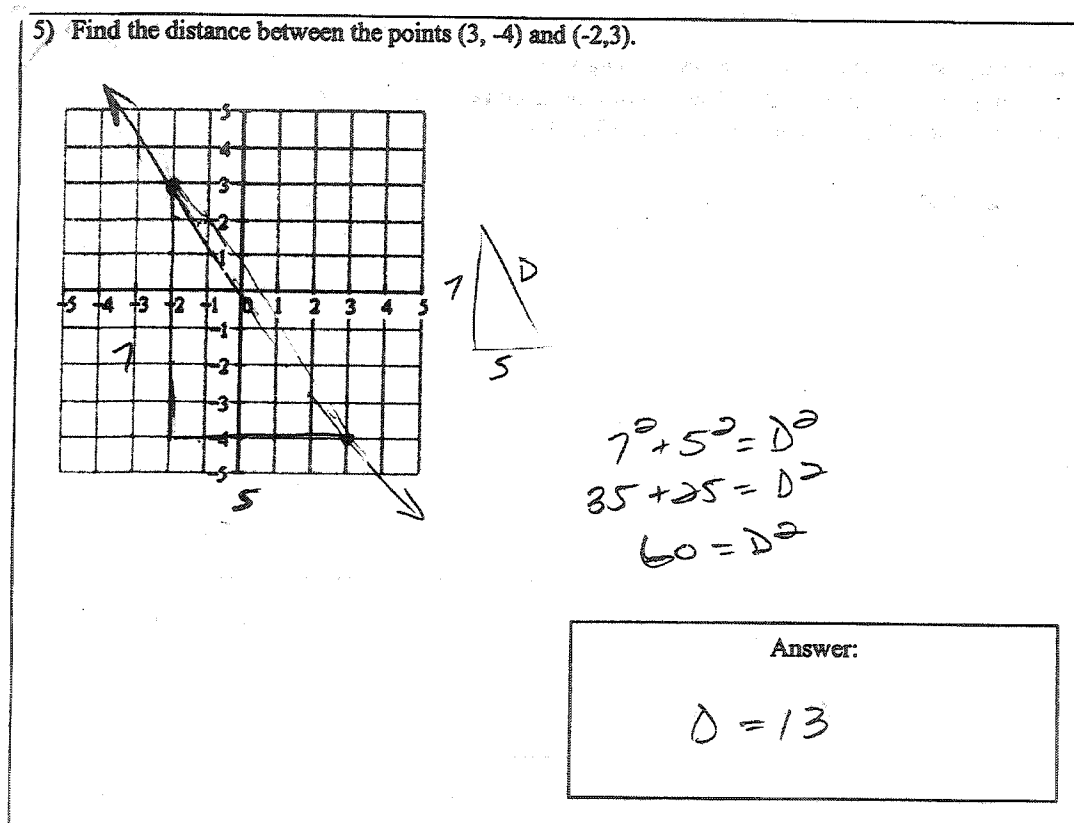

Figure 60: A student work on the distance formula

This example is troubling in more ways than one. First, it shows that students can arrive, with the aid of their calculator, in a math class in which they may be likely to fail. (This student on two occasions confided to the researcher how her graphing

calculator helped her to get through high school math classes, and that she could not have passed her math classes without it.) Second, it shows how students with a poor view of the role of calculators in mathematics may pass through a math class without mastering the topics that they should, perhaps believing that they have no choice but to create and maintain this pretense. Third, the calculator may allow a student to hide his or her poor basic math skills, preventing him or her from receiving the remedial help he or she needs to succeed in not only a current math class, but subsequent ones as well. (The above student received a “B” in this Pre-Calculus class, but, in the opinion of this researcher, possesses at best an 8th grade level of mathematical skill. Is it possible that the graphing calculator has set this student up for failure in her next mathematics class?)

Because of examples like the one above, teachers may need to think more about their assessment strategy when graphing calculators are a part of the class. By taking time to observe what students actually do with their graphing calculators, rather than hope that they are using them in ways of which we approve, we may discover things about our students which will help us gauge more effectively whether or not the graphing calculators are helping as we intend them to help. We may find that some students are using the calculator to hide their lack of basic skills; we may discover ways in which students may be attempting to fool us on assessments, and we may learn from our students things about our calculators that we did not know before (this researcher certainly did). We may even learn that our students are capable of using the calculator in

more creative and imaginative ways that even we could have imagined. This may mean spending more time with our students in small group or one-on-one situations, thus implying a closer look at how we allot time in our classrooms.

Researchers have pointed out on many occasions that graphing calculators have the potential to enhance mathematics education (see Chapters 1 and 3). However, creating and utilizing naïve assessments may create an atmosphere in our classroom that makes it more likely that students will choose inappropriate ways to use their calculator rather than ways in which we desire them to use them. In the simplest example, if the students discover (or are told by our previous students) that our assessments are naïve, and can be passed by reproducing calculator procedures that have little meaning to them, we may be robbing them of the opportunity to use the calculator in ways that research is telling us will benefit them. Even worse, students who previously have had the habit of using the calculator in ways of which we would approve may come to use the calculator in ways that we may not approve. (See Appendix E for a fascinating example of how students can use the Internet to download computer programs designed to solve standard Pre-Calculus problems. This website and others like it enabled a certain talented student to write programs to solve some of the standard problems posed in the class. He shared these programs with many of the other students, who in many cases used these programs to solve problems that they clearly could not have without the programs.)

Teachers may often mistakenly believe that their students think about graphing calculators in the way that they do. (This was definitely true in the case of the two teachers involved in this research study.) Teachers may be led into the trap of thinking that the way they use the calculators will inevitably be the way the students do. This may not necessarily be true, given that the student has so little calculator experience compared to the instructor. Perhaps it is overly optimistic to expect students to come to use the calculator as the “expert” teacher does, given the small amount of training time available in a standard mathematics class. In this research study, the instructors were frustrated on many occasions that only a few students seemed to utilize the calculators in ways that they had personally demonstrated. Another danger is that by demonstrating to our students ways in which to use the calculator, we may actually hinder them from utilizing the calculator in other creative and imaginative ways that we ourselves may not have thought of, especially if they get the idea that we are the “expert,” and that no other uses are possible other than the ones we model.

When this researcher was observing students, he often could not help but try and predict what the student would do with the calculator next. In the vast majority of cases, what I would have done next is not what the student actually did. (In fact, in several cases, this was actually a good thing, because the student made an imaginative and creative use of the calculator that had not occurred to me.) The value of seeing the

calculator as an open-ended tool, not limited by a proscribed number of uses, cannot be over-emphasized. Seeing the calculator in this limited way may create students who see the calculator only as something with which to imitate the instructor.

As mathematics teachers reflect on the use of graphing calculators in their classrooms, we may need to be use extra care in creating our assessments, recognizing that it may take strenuous effort to create assessments that are not “naïve.” We may need to recognize that students may overstate the help that the calculator is giving them, and they may understate it as well. Given the undeniable fact that students learned math before the existence of graphing calculators, we would do well to remember that it is possible that our students may have learned in ways that did not involve their graphical calculators, but these ways might be obscured by their claim that it was the calculator that made it possible. We may not therefore properly evaluate various teaching methods that we employ, and the effective techniques we use may not get the proper credit. The graphing calculator may genuinely help students in ways that we wish to know about, but if for some reason they don’t report it or we do not detect it, we cannot learn from their positive experiences. All of the above means that we may need to spend more time in closer contact with our students when they are using their calculators.

Suggestions for Further Research

The data herein suggest additional research questions about student and instructor use of graphing calculators. First, how can we make it more likely that students have a more realistic view of the effectiveness of their calculators, so that “inappropriate” uses will be less likely? Second, how can teachers modify their assessment practices to better reveal what students actually know and are likely to retain, given the complex nature of student interaction with their graphing calculators? Third, if we assume that teachers need to be more involved with students in order to learn more about their calculator usage, how do we go about allowing teachers this extra time? Also, what can teachers (or administrators) do to enable teachers to gain this crucial time?

Possible Limitations of the Study

This research study was based primarily on the observations made by the researcher looking for ways in which students used or did not use their graphing calculators. Since there were clearly times when the students could not be observed, it is obvious that the researcher was seeing only a subset of each student’s calculator usage. Students may have benefited or been hindered by their calculator use and these situations may have never been brought to light. For example, a student may have come to an understanding of a topic with the aid of his or her calculator, but later in the

presence of the researcher reveal an understanding of this topic without using the calculator. It should also be recognized that the students were not a random sample, but chose either to participate or not to participate.

It should also be noted that much of the researcher's conclusions were based on the degree of understanding that students had acquired, and that discovering and measuring this degree were quite difficult. This is especially true when noting that many students, even undergraduate students, have difficulty in expressing themselves clearly when asked to talk about their mathematical ideas and understandings. Many students who participated in the study may not have learned math in classrooms in which they were expected to communicate their ideas regularly. It is quite possible that the results here may be skewed by the fact that much of the data was collected in one-on-one situations in which students may have felt uncomfortable being asked to talk about their ideas and understandings.

It might be argued that the data from the exit interviews may be suspect, because the students were asked to solve problems which were not exactly like the ones they had seen before in the class. It is true that exit interview problems may have been such that students needed to analyze and think a bit harder than usual, but clearly each exit interview problem can be solved with the use of procedures and concepts covered in the class. This researcher feels quite strongly that genuine mathematical assessment often

involves the solving of “novel” problems. Thus there may be a philosophical difference in the way the reader and this researcher feel about this issue.

It might be believed that the students in this study may be different from other undergraduates, and thus fall outside the norm of “standard” undergraduate students. This researcher has taught and studied undergraduate students in several parts of the country and has no reason to believe that this set of subjects contains any signs of such an abnormality. The instructors also were not in any way unusual, nor were the textbooks and classroom activities out of the ordinary.

This researcher might be faulted for criticizing the instructors for using naïve assessments, when, if placed in their shoes, he may have also created assessments which may have turned out to be equally or even more naïve. This is freely admitted. The difficulty of creating genuine assessments is not implied to be either easy or time-friendly, especially given that fact that graphical calculators are constantly including more and more features of which even the best teacher may not be aware. The researcher understands the complex nature of assessment, but on the other hand, does mean to gently imply that the instructors may have done a better job creating assessments.

Conclusion

Mathematics education researchers have for almost twenty years now been keenly interested in how and why graphing calculators help students learn and retain mathematics. As researchers continue to look into the potential of graphing calculators to help students, what can this research study contribute to the conversation? Perhaps first is that it is difficult to imagine a situation in which a researcher will not see a clearer picture of graphing calculator usage by spending even a minimal amount of time with subjects. Second, this study is clearly an encouragement to those who feel that qualitative measures of student graphing calculator usage are worthwhile. Third, it would certainly be a mistake to conclude that we know enough about graphing calculators to say that we know that if we use them a certain way, that the results will necessarily be beneficial. This is especially true given that these tools will inevitably increase in complexity. Finally, the opinions of researchers and teachers should also be informed by the undeniable fact that graphing calculators have the power to both help as well as hinder mathematics students. A dogmatic belief in their unfailing efficacy or an unreasonable sense that they are almost certain to cause harm are both unhealthy attitudes for a researcher or a teacher to possess.

References

Acelajado, M. (2003). The Impact of Using Technology on Students' Achievement, Attitude and Anxiety in Mathematics. Available online 03/07/05 at <http://www.icme-organisers.dk/tsg15/Acelajado.pdf> .

Balacheff, N. (1986). Cognitive versus situational analysis of problem-solving behaviours. *For the Learning of Mathematics*, 6(3), 10-12

Bond, E. (1988). Diversity of microcomputer implementation: A process perspective. *Journal of Research on Computing in Education*, 24(4), 321-330.

Branca, N., Breedlove, B. and King, B. (1992). Calculators in the Middle Grades: Access to rich mathematics. In Fey, J. (Ed.), *Calculators in mathematics education*. National Council of Teachers of Mathematics, Reston, VA.

Beckmann, C. (1989) "Effects of Computer Graphics Use on Student Understanding of Calculus Concepts." Ph.D. diss., Western Michigan University. *Dissertation Abstracts International*, 50, 1974B.

Bush, W. (1934). A Student-Made Slide Rule. *Mathematics Teacher*, 27, 405 - 408.

Casey, D. (2001). A Cultural of a Science Classroom and Graphing Calculator-based Technology. Available online 11/09/04 at <http://scholar.lib.vt.edu/theses/available/etd-12052001-221551/unrestricted/edfront.PDF>

Cassity, C. (1997). Learning with technology: Research on graphing calculators. *Proceedings of Selected Research and Development Presentations at the 1997 National Convention of the Association for Educational Communications and Technology*. Illinois: Association for Educational Communications and Technology.

Chandler, P. (1993). The Effect of the Graphing Calculator on High School Students' Achievement. (Doctoral Dissertation, University of Houston, 1992). *Dissertation Abstracts International*, 53, 3832A.

Charles, R. (1999). Calculators at the Elementary School Level? Yes, It Just Makes Sense! *Mathematics Education Dialogues*, May/June, page 11.

Connell, M. (1998). Technology in Constructivist Mathematics Classrooms. *Journal of Computers in Mathematics and Science Teaching*, 17(4), 311-338.

Crocker, D. (1991). A Qualitative Study of Interactions, Concept Development and Problem-Solving in A Calculus Class Immersed in the Computer Algebra System. (Doctoral Dissertation, The Ohio State University, 1991). *Dissertation Abstracts International*, 53, 3832A.

Davis, R. (1992). Reflections on Where Mathematics Education Now Stands and on Where It May Be Going. In D. Grouws (Ed.) *Handbook on Research in Mathematics Teaching and Learning*, New York: Macmillan, 724-732.

Demana, F. & Waits, B. (1990). The Role of Technology in Teaching Mathematics. *Mathematics Teacher*, 83, 27-31.

Drijvers, P., & Doorman, M. (1996). The Graphics Calculator in Mathematics Education. *Journal of Mathematical Behavior*, 15, 425-440.

Dubinsky, E. (1991). Reflective Abstraction. In D. Tall (Ed.), *Advanced Mathematical Thinking*. (pp 101-123). Boston: Kluwer Academic Publishers.

Dugdale, S., Thompson, P., Harvey, W., Demana, F., Waits, B., Kieran, C., McConnell, J., & Christmas, P. (1995). Technology and algebra curriculum reform: Current issues, potential directions, and research questions. *Journal of Computers in Mathematics and Science Teaching*, 14, 325-57.

Dunham, P., & Dick, T. (1994). Connecting Research to Teaching: Research on Graphing Calculators. *Mathematics Teacher*, 87 (6), 440-45.

Ericsson, K., & Simon, H. (1993). *Protocol Analysis: Verbal Reports as Data*. Cambridge MA: MIT Press.

Farrell, A. (1996). Roles and behaviors in technology-integrated pre-calculus classrooms. *Journal of Mathematical Behavior*, 15(1), 35-53.

Gaslin, W. (1975). A Comparison of Achievement and Attitudes of Students Using Conventional or Calculator-Based Algorithms for Operations on Positive Rational numbers in Ninth-Grade General Mathematics. *Journal for Research in Mathematics Education*, 6(2), 95-108.

Giamati, C. (1991). The effects of graphing calculator use on students' understanding of variations on a family of equations and the transformation of their graphs. *Dissertation Abstracts International*, 52, 103A.

Goldenberg, E. (1988). Mathematics, metaphors and human factors: Mathematical, technical, and pedagogical challenges in the educational use of graphic representations of function. *Journal of Mathematical Behavior*, 7, 135-173.

Graham, J. (1998). The effect of graphing technology on student performance in the study of functions. Available 03/07/05 at <http://www.westga.edu/~jgraham/thesis1.htm>.

Grouws, D. & Cebulla, K. (2000). Improving Student Achievement in Mathematics. *Clearinghouse for Science, Mathematics, and Environmental Education*, December 2000. Available 03/07/05 at <http://www.ericse.org/digests/dse00-09.html>.

Harry, V. (2000). Technology Advancing a Continuous Community of Learners (TACCOL): *Integrating Technology into Teacher Preparation*. Paper presented at the Annual Meeting of the American Association of Colleges for Teacher Education (52nd, Chicago, IL, February 26-29, 2000.

Harvey, John G. (1993). Effectiveness of Graphing Technologies in a Pre-calculus Course: The 1988-89 Field Test of the C²PC Materials. Paper presented at the Technology in Mathematics Teaching Conference, Birmingham, England, September 1993.

Harvey, J., Waits, B., & Demana, F. (1995). The influence of technology on the teaching and learning of algebra. *Journal of Mathematical Behavior*, 14, 75-109.

Heid, M. (1997). The technological revolution and the reform of school mathematics. *American Journal of Education*, 106, 5-61.

Hembree, R. & Dessart, D. (1986). Effects of hand-held calculators in precollege mathematics education: A meta-analysis. *Journal for Research in Mathematics Education*, 17, 83-99.

Hillel, J. (1992). The Computer as a Problem Solving Tool; It Gets a Job Done, But Is It Always Appropriate? In J. P. Ponte et al. (Eds.), *Mathematical Problem Solving and New Information Technologies: Research in Contexts of Practice*. Berlin: Springer.

Hollar, J. & Norwood, K. (1999). The Effects of a Graphing-Approach Intermediate Algebra Curriculum on Students' Understanding of Function. *Journal for Research in Mathematics Education*, v30 n2, 220-226.

Hylton-Lindsay, A. (1998). The effect of the graphing calculator on metacognitive aspects of student performance in precalculus for business. (Columbia University Teachers College, 1997). *Dissertation Abstracts International*, 58, 3449A.

Jones, P. (1993). Realising the educational potential of the graphics calculator. In L. Lum (Ed.), *Proceedings of the Sixth Annual International Conference on Technology in Collegiate Mathematics*. (pp. 212-217). Reading, MA: Addison-Wesley.

Keller, B. & Russell, C. (1997). Effects of the TI-92 on calculus students solving symbolic problems. *International Journal of Computer Algebra in Mathematics Education*, 4, 77-97.

Lapp, D. (1997). A Theoretical Model for Student Perception of Technological Authority: Impact on Instruction, Presented at the Third International Conference on Technology in Mathematics Teaching, Koblenz, Germany, 29 September-2 October 1997.

LaTorre, D. (1991). Revitalized undergraduate mathematics with symbol manipulating graphics calculators. Final report to Fund for the Improvement of Postsecondary Education: Washington, DC. (ERIC Document Reproduction Service No. ED 367 532)

Lauten, A., Graham, K. and Ferrini-Mundy, J. (1994). Student Understanding of Basic Calculus Concepts: Interaction with the Graphics Calculator. *Journal of Mathematical Behavior*, 13(2), 225-237.

Machlowitz, E. (1976). Electronic Calculators – Friend or Foe of Instruction? *Mathematics Teacher*, 69, 104-106.

McClendon, M. (1992). The Development of a Graphics Calculator Study Guide for Calculus Students. Ph.D. diss., University of Oregon. *Dissertation Abstracts International* 52, 2450A.

Meel, D. (1997). Assessment in a calculator available classroom: Some considerations, *Educational Assessment*, 4(3), 149-175.

Milou, E. (1997). The Graphing Calculator: A survey of Classroom Usage. *School Science and Mathematics*, 99(3), 133-140.

Mingus, T. and Grassl, R. (1997). Using Technology to Enhance Problem Solving and Critical Thinking Skills. *Mathematics and Computer Education*, v31 n3, 293-300.

Mokros, J., and Tinker, R. (1987). The impact of microcomputer-based labs on children's ability to interpret graphs. *Journal of Research in Science Teaching*, 24(4), 369-383.

Nachmias, R., & Linn, M. (1987). Evaluations of science laboratory data: The role of computer-presented information. *Journal of Research in Science Teaching*, 24(5), 491-506.

Nygaard, P. (1934). Accuracy in Addition; Calculating Machines Versus Addition. *Mathematics Teacher*, 27, 153 -155.

O'Callaghan, B. (1998) Calculators, Attitudes, and Success. Available online 11/04/04 at <http://archives.math.utk.edu/ICTCM/EP-10/C19/pdf/paper.pdf> .

Penglase, M., & Arnold, S. (1996). The graphics calculator in mathematics education: A critical review of recent research. *Mathematics Education Research Journal*, 8, 58-90.

Ponte, J., & Canavarro, A. (1993). Graphics calculators in the classroom: Students' viewpoints. *Proceedings of PME 17*, 2, 33-40. Tsukuba, Japan.

Porzio, D. (1997). Examining Effects of Graphics Calculator Use on Students' Understanding of Numerical, Graphical and Symbolic Representations of Calculus Concepts. Paper presented at the Annual Meeting of the American Educational Research Association (Chicago, IL, March 1997).

Quesada, A. and Maxwell, M. (1992). The Effect of Using a Graphing Calculator on Students' Performance in Pre-calculus: A Preliminary Report. In *Proceedings of the Fourth International Conference on Technology in Collegiate Mathematics*, edited by Lewis Lum, 380-84. Reading, Mass.: Addison-Wesley Publishing Co.

Quesada, A. and Maxwell, M. (1994). The effects of using graphing calculators to enhance college students' performance in Precalculus. *Educational Studies in Mathematics*, 27(2), 205-15.

Reys, R., Bestgen, J., Rybolt, F., & Wyatt, W. (1980). Identification and characterization of computational estimation processes used by in-school pupils and out-of-school adults. Final report, grant no. NIE 79-0088. Columbia, Mo.: University of Missouri.

Rich, B. (1991). The Effect of the Use of Graphing Calculators on the Learning of Function Concepts in Pre-calculus Mathematics. Ph.D. diss., University of Iowa. *Dissertation Abstracts International* 52 (1991); 835A.

Ruthven, K. (1990). The influence of graphic calculator use on translation from graphic to symbolic forms. *Educational Studies in Mathematics*, 21, 431-50.

Schoenfeld, A. (1988). When Good Teaching Leads to Bad Results: The Disasters of "Well-Taught" Mathematics Courses. *Educational Psychologist*, 23(2), 145- 166.

Schoenfeld, A. (1989). Exploration of Students' Mathematical Beliefs and Behavior. *Journal for Research in Mathematics Education*, 20, (4), 338-355.

Shoaf-Grubbs, M. (1992). The Effect of the Graphics Calculator on Female Students' Cognitive Levels and Visual Thinking. In *Proceedings of the Fourth International Conference on Technology in Collegiate Mathematics*, edited by Lewis Lum, 394-98. Reading, Mass.: Addison-Wesley Publishing Co.

Simmt, E. (1997). Graphing Calculators in High School Mathematics. *Journal of Computers in Math and Science Teaching*, 16(2/3), 269-289.

Simon, A. (1999). Two Modes of Mathematics Instruction. In: Issues of Education at Community Colleges: Essays by Fellows in the Mid-Career Fellowship Program at Princeton University.

Simonsen, L., & Dick, T. (1997). Teachers' perceptions of the impact of graphing calculators in the mathematics classroom. *Journal of Computers in Mathematics and Science Teaching*, 16, 239-268.

Slavit, D. (1994). The effect of graphing calculators on students' conceptions of function. Paper presented at the annual meeting of the American Educational Research Association, New Orleans.

Slavit, D. (1996). Graphing calculators in a "hybrid" Algebra II classroom. *For the Learning of Mathematics*, 16, 9-14.

Smith, B. A. (1997). A meta-analysis of outcomes from the use of calculators in mathematics education. (Texas A&M University, 1996). *Dissertation Abstracts International*, 58, 787A.

Szetela, W. & Super, D. (1987). Calculators and Instruction in Problem Solving in Grade 7. *Journal for Research in Mathematics Education*, 18, 215-229.

Tall, D. (1989). New Cognitive Obstacles in a Technological Paradigm, *Research Issues in the Learning and Teaching of Algebra*, National Council of Teachers of Mathematics.

Tharp, M., Fitzsimmons, J. and Ayers, R. (1997). Negotiating a Technological Shift: Teacher Perceptions of the Implementation of Graphing Calculators. *Journal of Computers in Mathematics and Science Teaching*, 16(4), 551-575.

Thompson, D., and Senk, S. (2001). The effects of curriculum on achievement in second-year algebra: The example of the University of Chicago School Mathematics Project. *Journal for Research in Mathematics Education*, 32(1), 58-84.

Usiskin, Z. (1978). Are Calculators a Crutch? *Mathematics Teacher* 71, 412-413.

Ward, R. (1998). Graphing Calculator-Associated Misconceptions Among High School Students, California Polytechnic State University - San Luis Obispo. Available at <http://www.calpoly.edu/~raward/ictcm.html>

Webb, H. (1921). The Future Of Secondary Instruction In Mathematics; Suggestions for changes in course content. *Mathematics Teacher*, 14, 337 -341.

West, P. (1991). Sold on a new machine. *Teacher Magazine*, 3(2), 18-19.

Williams, C. (1993). Looking over their shoulders: Some difficulties students have with graphing calculators. *Mathematics and Computer Education*, 27 (3), 198-202.

Wilson, M. and Krapfl, C. (1994). The Impact of Graphics Calculators on Students' Understanding of Function. *Computers in Mathematics and Science Teaching*, 13(3), 252-264.

Appendix A: Author's Previous Research

Twelve second semester calculus students attempted to solve each of the following calculus problems. There was no time limit, and the students were adequately familiar with their graphing calculators:

- 1) Find any maximums and minimums of the following function: $y = \frac{8}{x^2 + 4}$
- 2) For the two graphs $y = \frac{8}{x^2 + 4}$ and $y = \frac{1}{2}x$, find all the points of intersection.
- 3) Evaluate $\int_1^3 (x^3 - 6x^2 + 11x - 6) dx$
- 4) Given two functions, the parabola $y = x^2 + 2$ and the line $y = kx$, with k a real number greater than zero, find k such that the line is tangent to the parabola. Then find the point of tangency.
- 5) $f(x) = x^3 - 6x^2 + p$, where p is an arbitrary real number. For what values of p does $f(x)$ have three distinct real roots?

All the students used their graphing calculator extensively on at least four of the five problems. In the exit interview, unaware that they had gotten *all* of the problems wrong, three of the students claimed that the graphing calculator was very useful in solving the problems.

Appendix B: Questions to be “Seeded” on Homework

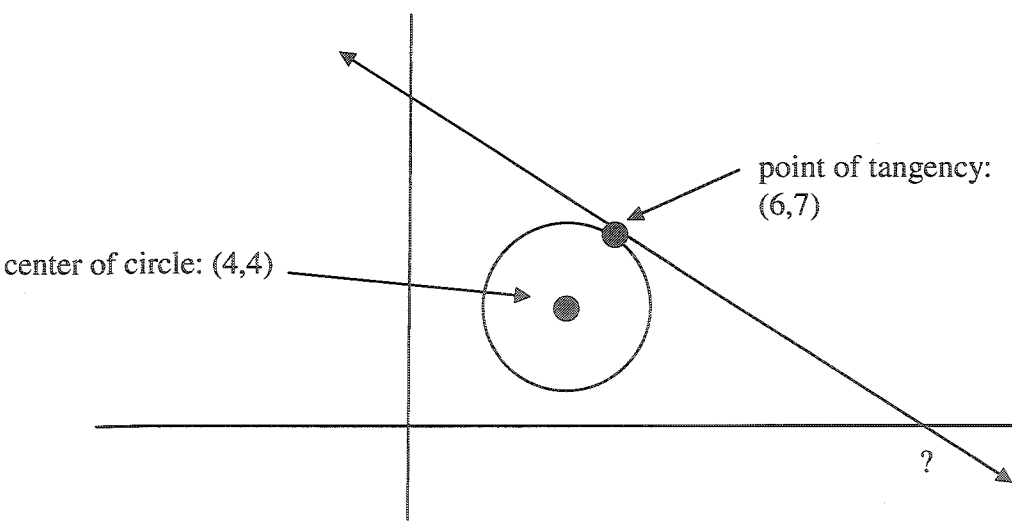
Problems dealing with linear functions and their applications	
Solve for x:	$\frac{3}{4}\left(2x - \frac{1}{5}\right) = \frac{5}{2} + \frac{x}{6}$
Find the equation of the line passing through the points $(-3, 2)$ and $(4, -1)$. Where does this line cross the x-axis?	
Find the equation of the line perpendicular to the line $y + 2x = 3$ which contains the point $(6,2)$.	
A particular town has only adults in it. $\frac{2}{3}$ of the men are married to $\frac{3}{5}$ of the women. What fraction of the adults in the town are married?	
Determine m and b such that the line $y = mx + b$ is the perpendicular bisector of the line segment whose endpoints are $(-6,1)$ and $(2,-3)$.	
Find B and C so that each point on the line $x + By + C = 0$ is equidistant from the point $(-3,3)$ and $(5,-5)$	
A line passing through $(-2,0)$ and $(4,c)$ is perpendicular to the line $y = 5x + 7$. Find c.	
A room in Julie’s house is 14 feet by 10.5 feet. She wants to remodel the room by adding the same distance to both the length and width and have the perimeter of the room doubled. How much should she add to the length and the width?	
Solve for x: $0.301x = 0.903x$	
Find where the tangent line crosses the x-axis. (Hint: the tangent line and the segment containing the center of the circle and the point of tangency meet at a 90° angle.)	
 <p style="text-align: center;">center of circle: $(4,4)$</p> <p style="text-align: center;">point of tangency: $(6,7)$</p> <p style="text-align: right; margin-right: 10%;">?</p>	
32 degrees Fahrenheit equals zero degrees Celsius. 212 degrees Fahrenheit equals 100 degrees Celsius. Find the relationship between Fahrenheit and Celsius.	

Problems dealing with systems of equations

The point $(1,5)$ lies on the line $y = 2x + 3$. If you travel a length of 4 along the length of the line, at what point (x, y) would you be? (see diagram)

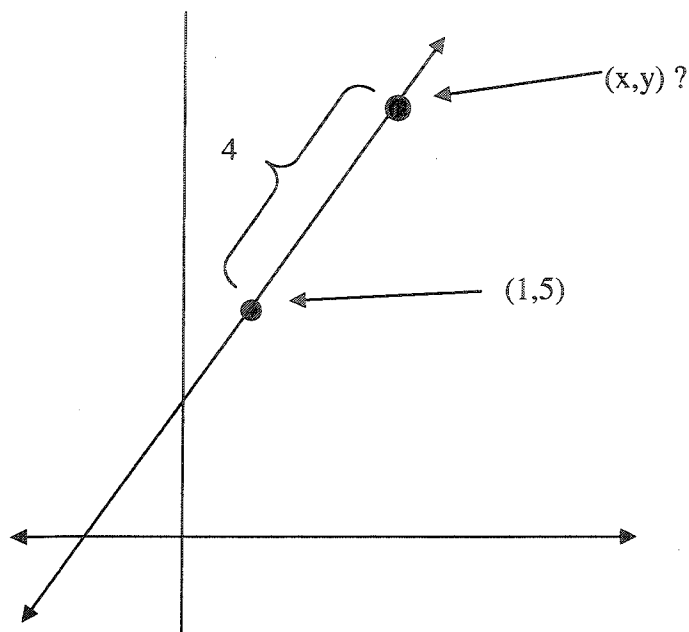

Find the intersection of these two lines: $y + 4 = 2x$ and $x - 3y = 2$

The perimeter of a rectangle is 20 inches. If its diagonal is 8 inches, find the dimensions of the rectangle. An exact answer is preferred, but if you give a decimal approximation, give your answer to the nearest thousandth of an inch (three decimal places).

John and Susan are experimenting with chemical reactions and measuring their temperature. At the start of John's experiment, the temperature was 45 degrees Fahrenheit, and it dropped by 6.75 degrees every minute. Initially, the temperature in Susan's experiment was -12 degrees Fahrenheit and dropped by 1.5 degrees every thirty seconds. If they started their experiments at exactly the same time, after how long will the temperatures in John and Susan's experiments be exactly the same?

Find the intersection of these two lines. $\frac{x}{3} + \frac{y}{4} = 3\frac{1}{8}$ and $\frac{x}{5} + \frac{y}{6} = 1\frac{19}{20}$

Find the area of the triangle below:

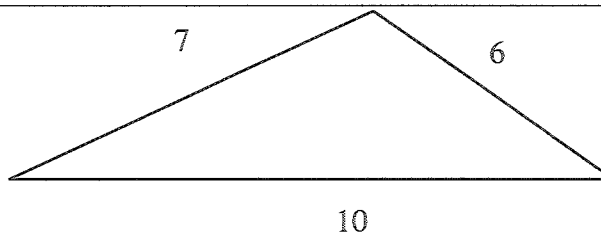

What is the shortest distance between the line $y = 2x + 3$ and the point $(6,1)$?

Problems dealing with quadratic functions and their applications

Find the two points on the line $y = 2x + 1$ that are at a distance of 3 from the point $(3,4)$

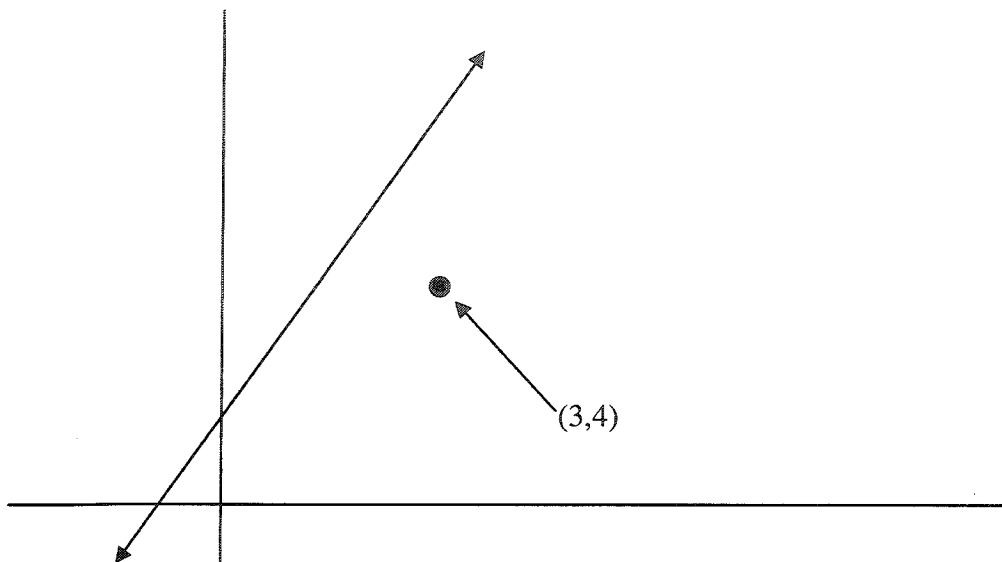

Given two functions, the parabola $y = x^2 + 2$ and the line $y = kx$, with k a real number greater than zero, find k such that the line is tangent to the parabola. Then find the point of tangency.

Consider the quadratic equation $x^2 + 9 = bx$. For what value(s) of b does the equation have only one solution?

Find k such that the quadratic equation $x^2 + 2(k+2)x + 9k = 0$ has exactly one solution.

Find the least integer c for which the equation $-3x^2 + 7x + c = 0$ has real solutions

Write a quadratic equation having the solutions $-2/3$ and $4/5$.

A room in Julie's house is 14 feet by 10.5 feet. She wants to remodel the room by adding the same distance to both the length and width and have the area of the room doubled. How much should she add to the length and the width?

A flower bed is 9 yards by 7 yards. It is surrounded by a gravel path of uniform width. The gravel path has an area equal to the area of the flower bed. Find the width of the gravel path to two decimal places..

Problems dealing with exponential or logarithmic Functions and Equations

Solve for x: $\log x + \log(x+15) = 2$

Solve for x: $x - 5 = (x+7)^{1/2}$.

In a pond there are 1000 mosquitoes at the beginning of an experiment. After 3 days, there are 2000 mosquitoes. Assuming that their population is compounding continuously, and that they continue to reproduce at the same rate, how long will it take for there to be 4000 mosquitoes?

At what rate of interest must money be invested in order to quadruple itself in 15 years if the interest is compounded monthly?

Fill in the blank: $2^x + 2^x + 2^x + 2^x = 2^?$ (In other words, 2 to what power?)

In a test tube, a certain bacteria quadruple every 6 hours. After 15 hours, there are 1560 bacteria. How many bacteria were present originally?

If $32^p = 64$, find p.

Find all x such that $32x^{2/3} = x^{3/2}$

$\log_3 50 = ?$

Solve the following equation for x: $\sqrt{x} + \sqrt{4x} = \sqrt{48}$

Solve for x: $0.5 = \log_{10} \frac{x}{0.2}$

$2^{2x} + 4^x = 8$ (in other words, 8 to what power?)

Appendix C: Exit Interview Calculator Questions

When did you first begin regularly using a graphing calculator in mathematics classes?

Could you briefly relate your mathematical background in high school and college?

How did your graphing calculator help you understand the concept of linear equations and functions?

How did your graphing calculator help you understand the concept of quadratic equations and functions?

How did your graphing calculator help you understand the concept of exponential and logarithmic equations and functions?

How did your graphing calculator help you understand the concept of systems of equations in two variables?

Think of an example or two in which you felt the graphing calculator was particularly useful in helping you understand a certain topic or concept.

Think of an example in which you felt the graphing calculator was essential for understanding a certain topic or concept.

Appendix D: Exit Interview Problems

<p>Linear equation or function problem</p>	<p>In an alloy of 90 ounces of silver and copper there are 6 ounces of silver. How much copper must be added to the alloy so that 10 ounces of the new alloy contain $\frac{2}{5}$ of an ounce of silver?</p>
<p>Quadratic equation or function problem</p>	<p>One solution to the equation $kx^2 + 10x = 8$ is -4. What is the other solution?</p>
<p>System of equations in two variables problem</p>	<p>A right circular cone has a radius of 4 and a height of 12. How high must the cone be filled up with water so that the cone is half full of water? (The volume of a cone is $\frac{1}{3}\pi r^2 h$.)</p>
<p>Exponential or logarithmic problem</p>	<p>Rewrite the expression $\frac{3}{2^{(2x-1)}}$ in the form $A[b^x]$.</p>

Appendix E: Programmable Calculator Web Site

<http://www.ticalc.org/community/surveys/45.html>

The following are excerpts from this website that describe how students view the capabilities of their graphing calculators. Spelling and grammar are unchanged.

I somewhat agree with you. It's true, we would have learned more in class if these things were never made. A lot of us spend a majority in class fiddling with the buttons to play games and such. However, many of us, for example I, use our noggins to create ingenious programs which do the work for us. Not just any dumbass can do this; it takes a remarkably intelligent dumbass to do this kind of work. It's obvious some of us are just slacking and using other people's programs, but I take pleasure in helping these dumbasses pass their classes. In fact, the other day in summer school, my program mathwhiz inspired one of my classes to take up programming. Interesting.

I know. I got bored one day and made a program on my 83+ that used Newton's method to find the zero of a function. But it gets better! I also integrated a Radical program so if the zero turned out to be a square root, it would detect it, and simplify it. So if my function was x^2-8 , it would detect $\text{Sqrt}(8)$, and simplify it to $2\text{Sqrt}(2)$. hehe. Nobody else could do that though (pretty easy imo)

My point exactly! I know the concept much better after I program it. Sometimes I get stuck on something, and I have to think hard about it. The point of making a program is to speed up the process. That's what calculators were originally created for. I still understand the principles of what the program does.

A ti-83(+) can ruin algebra for you.. You get hooked on using it for graphing and stuff, and write programs to do the work for you. Then you get screwed over when the stuff gets tough and you don't know how to do the easy stuff..

i say that calcs should be used as little as possible. the first thing my calculus teacher did was show us how calculators can give misleading information (just keep zooming in on your graph, and you'll see why). besides, Isaac Newton was able to prove that planets travel in ellipses without a calculator. all that calculators are good for is to handle many numbers and be extremely accurate. my favorite thing that they can do is direction fields- try drawing one by hand.

I feel that teachers should make you learn the stuff. Mine did even though I and some of my friends had an 86, 89, and 92Plus's as they came out (or as we could afford them.) When the teacher realized that we could blast through his tests with these calculators built in functions, our written programs, and the wonderful programs from www.ticalc.org he started making tests that he would not let us use the calculators on to test our knowledge on the stuff, and he would do it randomly and without warning. This idea carried on to the next teacher and so on.

I really appreciate this because we were beginning to become dependent upon our calculators for everything and this way of teaching really helps you to learn problem solving and increases what you know in other areas like Physics, Computer Programming and Statistics. If you rely on your calculator for all of the answers how will you ever make it when the batteries go dead?

Appendix F: Description of Supersubjects

“Alex”

Alex was a 19-year old sophomore who had three years of high school math. He mentioned that he got all A's and B's in his high school classes, and is generally pleased with his mathematical preparation. He has taken an Algebra refresher course to prepare himself for this class because he had a placement test score that his advisor predicted would make it difficult for him to be successful in this Pre-Calculus class. He took the Algebra class during the last semester of his freshman year, and was very confident that he would pass the class. Like many undergraduates, his basic math skills were a bit rusty, and frequently made use of his calculator to perform elementary calculations. He learned and retained much during the class, but his calculator was not as useful as he claimed it was.

“Brad”

Brad is a product of a local private school, is 18 years old, and is taking the Pre-Calculus class during his Freshman year. He wanted to take Calculus immediately, but was required by his placement test to take Pre-Calculus first. He is looking forward to getting this class “out of the way” so he can get to Calculus. His mathematical disposition is such that he attempts to fit math problems into categories that he has solved before, and his memory is very good, in that when he recognizes a problem, he is

quite good at fitting the problem into his mental model of what he did the last time he had a problem of that sort. Like many math undergraduates, he had a great deal of difficulty with problems that he had never seen before and was quite critical when asked to do these by either me or the professor. His basic mathematical skills, such as algebraic manipulations and equation solving were poor, and he used his calculator primarily for basic calculations, and so provided little data.

“Cathy”

Cathy was the student who didn't know what “e” was. She was a junior who had two previous math classes before taking this one. This was going to be the last math class she would have to take to fulfill the math requirement for her degree. Cathy was very concerned that she should be able to convert the math problem to a formula or equation right away. She was not likely to think about the problem a great deal before writing something down, and was very uncomfortable when working on a problem that she had not encountered before. She even claimed on one occasion that it was unfair to ask her to do a mathematics problem that she had not seen before. Her memory was impressive, in that she was able to memorize long sequences of procedures in order to find an answer to a problem.

“Darla”

Darla usually overstated how much help her calculator was giving her. She was quite proud to relate that her high school math teacher had shown her all sorts of uses for it. She spoke highly of her high school mathematics experience. I noticed that when she had used the calculator in a certain way she was very quick to use it in that way again, even if such a use was not really applicable to the new problem. She was never observed using the calculator in an imaginative way. There were several instances when she could have used the calculator to find an error, but I never recorded an instance of her doing so.

“Elmer”

Elmer spoke quite highly of his calculator, but used it only to do simple mathematics, such as division, multiplication, subtraction and addition. He was never observed using it for graphing, exploration, or checking an answer. When I first noticed him using it during class, he seemed to be using it a lot. I subsequently discovered that he evidently used it for simple math exclusively. He reported that the calculator helped him in all four categories, but he never used its advanced features. When the instructor or lab assistant used the calculator to demonstrate a more advanced feature, he rarely paid much attention.

“Freda”

Freda was a freshman with four years of math in high school and was a little disturbed at having to take this Pre-Calculus class, because it seemed to be a repetition of her math class while a senior. Freda seemed very confident in her mathematical abilities, and at first seemed a little put off when I asked her to explain her thinking, as if I didn't believe her. She was one of the students who could mimic calculator procedures quite effectively, but often forget the procedures very quickly. At times, she seemed blissfully unaware of major blunders, and felt that once she had used the calculator to get an answer, there was no reason to try and corroborate her answer. She was able to solve problems with the calculator, but these procedures stayed with her for an extremely limited period of time.

“Greg”

Greg was very enthusiastic about his graphing calculator, but seemed to be ignorant of even the most basic concepts, such as the slope of a line. He frequently overstated the help his calculator was giving him.

“Helen”

Helen was a little concerned about her high school math experience. She said that she always felt that other students were “getting” it, and she wasn’t. She said on several occasions that when she wanted to think more deeply about a problem, the class had to move along. Helen was a very deliberate, and at first seemed to be a little slow. What I later discovered was that she was a very thorough thinker, and what seemed to be slowness was actually her really thinking about the problem, and even foreseeing ways to corroborate her thinking. For example, while she was thinking about how to solve a linear equation, I later discovered that she was thinking about how to use her calculator to corroborate any potential answer she might have. In one case, she thought in advance about using the calculator to check her algebra work, and in another she used the calculator first to get an approximation, and then verified this answer with an algebraic equation. In this case, she also used the calculator’s solver feature to further verify her solution. But, interestingly, she later reported that the calculator was not helpful in solving either linear or quadratic equations. I saw her grow in her understanding, all the while using the calculator in imaginative and clever ways, but yet she downplayed the role of her calculator in helping her to learn. This is a perfect example of how a survey of student attitudes would miss some very important calculator uses.

“Isaac”

Isaac was quite clear that he considered the calculator helpful in having him learn lines, but his knowledge of lines was very poor. On the other hand, he reported that the calculator was not helpful in helping him about quadratics, but the evidence showed that the calculator did help him learn some things about quadratic equations and graphs. The instructor's demonstrations of quadratic functions seemed to help him, because he later used these procedures to solve problems. This is an excellent example to show that a student can both benefit and not benefit from the same calculator on different topics, and that to see the calculator as either only helpful or harmful is an oversimplification. It also shows how student input can be suspect in two different ways, first, that a student may overstate its usefulness, and second, that the student may not report positive uses.

“Janet”

Janet was a student who spoke very highly of her high school experience, and said that she got good grades in all four years. However, she was quick to point out during our sessions that she was usually unable to solve a problem unless she had done one like it before. Janet was one of the students that forgot calculator procedures very quickly. Her positive claims about her calculator seemed to spring from the fact that she had seemingly mastered these procedures.

“Kyle”

Kyle was an excellent student, and was one of three students whose assessment of the calculator was essentially the same as mine. When he claimed that the calculator was helpful to him, the evidence showed that this was true. Kyle was one of the few students who knew when he was in a situation in which the calculator was not going to be helpful. He also was one of the few who was able to use the calculator not only to find errors, but to use the calculator to correct them as well.

“Linda”

Linda spoke highly of both her high school mathematics experience and her knowledge of the topics covered in the class. She overstated the help her calculator gave her. For example, her knowledge of logarithms, a topic covered in the class, was abysmal, and yet she cheerfully claimed that she had a good knowledge of logarithms. Conversation revealed that her high school mathematics experience consisted in large part of using the calculator to solve problem by procedures which she quickly forgot.

“Michele”

Michele felt that the calculator was much too “sophisticated” to use for menial tasks such as multiplication and such. Her basic math skills were atrocious, but, oddly, she was never observed using the calculator to do “simple” mathematics. She reported

that the calculator helped, but it could have helped a lot more, such as helping her to do basic skills, which she herself admitted were poor.

“Nancy”

Nancy was one of the students who did not know how much she did not know. She had enormous confidence in her mathematical abilities, which in some part came from her high school mathematical experiences, which she claimed made her an excellent mathematics student. She seemed to believe that her cheerfulness would in itself inevitably lead to success in the mathematics classroom. Nancy had huge gaps in her mathematical understanding of which she was almost totally unaware. She was able, unfortunately, to hide these gaps from both herself and her instructor.

“Oliver”

Oliver was a student who was able to use the calculator with impressive efficiency to solve most of the problems on his homework and on his exams and quizzes. But he also had evidently forgotten many of these same procedures, because in our one-on-one sessions, he was unable to duplicate most of the calculator procedures that he had apparently mastered previously.

“Paula”

Paula and I had a philosophical difference when it came to definition of what it meant to understand the topic of system of equations. Her definition was that if you gave her a set of equations that she could plug into her calculator, she could then find the point of intersection. My definition was (and is) that understanding system of equations meant that sometimes it may be necessary to find the relationships between the variables (the equations) instead of them being provided to you. I also told her that it was important to have both the algebraic understanding of the equations, as well as a geometric understanding of the equations. She disagreed, and it is hard to blame her for having such a narrow view, because the assessments in the course that measured her understanding of systems of equations permitted her to solve most of such problems with her calculator. Her narrow view was never challenged (except by me), and since I was not assessing her, my definition did not interest her.

“Quentin”

Quentin's was the student who used his graphing calculator less and less during the semester, and his paper mathematical tables more and more. His story appears in Appendix G.

“Rita”

Rita was another student who had received, in her opinion, an outstanding high school mathematics experience, but yet revealed some extremely serious misunderstandings about what mathematics is. Her definition of success in mathematics was being able to mimic what the instructor did and remember it long enough to pass the test. She viewed her calculator as yet another tool to help memorize and reproduce the thinking of the instructor. I fear that her next mathematics class will be a failure unless she is able to reconsider her vision of mathematics.

“Steve”

Steve was the one of three students whose beliefs about his calculator were very accurate. One of the most fascinating things about Steve was that he was able to recall situations in which the calculator helped him, and also those in which the calculator hindered him. This was very unusual among the nineteen subjects. Most of the other student recollections had only to do with situations in which they believed (rightly or wrongly) that the calculator helped them. He also had a habit of talking about his calculator, trying to determine if it would be helpful or not, before he even touched it. It was as if he was imagining himself pressing buttons on the calculator in his mind, and thinking about whether or not the many procedures he could remember would help or not. And his impressions were almost always accurate. An outstanding student.

Appendix G: The Fascinating Case of Quentin

Quentin was a student who preferred paper mathematical tables to his graphing calculator. He at first used his graphing calculator occasionally, but as the semester went on he used it less and less, eventually not using it at all. The first thing that should be understood is how Quentin came to be a supersubject, even though he didn't use his graphing calculator much. When I first asked students to become supersubjects, I did not ask Quentin, because he did not seem to use his calculator enough to provide much useful data. I chose Quentin later after I saw him using his tables. I wanted to observe how he used his tables, and in particular, wondered under what circumstances he would use his tables and when he might use the graphing calculator.

To help the reader understand what Quentin was consulting, below is a likeness of an excerpt of the kind of tables that Quentin was using:

Angle	Sin	Cos	Tan
15 °	0.25882	0.96593	0.26795
16 °	0.27564	0.96126	0.28675
17 °	0.29237	0.95630	0.30573
18 °	0.30902	0.95106	0.32492
19 °	0.32557	0.94552	0.34433
20 °	0.34202	0.93969	0.36397

#	log
12.0	1.07918
12.1	1.08279
12.2	1.08636
12.3	1.08991
12.4	1.09342
12.5	1.09691

The story began with a very interesting twist. Quentin's instructor had a policy that nothing could be brought to exams except two pencils and a calculator. Quentin wanted to use his tables on the exam (they were on the front and back of a single sheet of paper), but the instructor told him he could not do so. On the first exam Quentin used his calculator as necessary and passed the exam. But prior to the second exam, Quentin wrote an email to the instructor asking for permission to use the tables on subsequent assessments. (Quentin showed me the email.) His main points were that there was nothing on the tables that could not be found on the calculator, and that he felt he learned and retained the material better by not overusing his calculator. The instructor replied that if he allowed one student to have extra materials for the test, a precedent would be set that would move other students to petition for their own extra materials to be used on the test. Quentin replied that if the other students would see his tables, no student would make such an argument. The instructor believed that Quentin was wrong, and made a copy of the table and showed the other students the table and explained the situation. After two weeks, when no other student made a request similar to Quentin's, the instructor relented and permitted Quentin to use his tables on subsequent assessments. (Note: Despite an extremely strong temptation, the researcher stayed out of the above negotiations.)

A second twist came up on the second exam. Quentin did not bring his graphing calculator to the second exam, and needed to calculate a certain trigonometric ratio that was not on his table. He needed to find the sine of 72.6° , but his table only gave the sine

of 72° and 73° . Using the approximate values given by his table of the sine of 72° , 0.95106, and the sine of 73° , 0.95630, he linearly interpolated and found that the sine of 72.6° was approximately 0.95420. (Because of the interpolation, this approximation is incorrect in the fifth decimal place.) The instructor marked his answer wrong, because the value of the sine of 72.6° he calculated was an approximation. Quentin argued (via email again) that even though his interpolation was an approximation, so was the value given by any calculator. He further argued that the instructor had given full credit on the problem to a student who had used a calculator to give only a three decimal approximation, even though the professor admitted that Quentin's approximation was accurate to four decimal places. The professor relented yet again, Quentin got his points back, and consequently passed the second exam also.

Quentin already had mastered some of the course material before the class even started, but it was his reaction to concepts that were new to him which was most fascinating. When the professor demonstrated the standard method for solving exponential equations, Quentin immediately mastered it, and also found an alternative method for solving them that amazed the instructor (and the researcher!) When the instructor demonstrated how to, given a data set, find the equation of an exponential function of the form $A = Pe^{rt}$ by graphing the data set on semi-logarithm paper, Quentin was the only subject who really "got it." This was discovered when the topic was brought up in the exit interview. All of the students other than Quentin admitted that

they did not understand it, but Quentin showed a profound knowledge of the procedure and could duplicate it with ease. Astonishingly, Quentin also devised an alternative way of finding, from the data set, the exponential function of the form $A = Pe^{rt}$, using an extremely clever idea involving a system of equations. His mathematical knowledge, combined with an abundance of curiosity, revealed a portrait of an extraordinarily talented student.

Conversations with Quentin revealed that his high school mathematics teacher felt very strongly about the overuse of calculators and insisted that students learn to read mathematical tables and draw graphs by hand before they were permitted to use graphing calculators. Quentin remarked that after he mastered the use of the tables and learned how to draw graphs of functions by hand, he never felt that the calculator was necessary. He thought that maybe he would learn new uses of the calculator in college, but after a few weeks decided that he would not need his calculator and gradually did not even bring it to class or use it to do homework.

Quentin was clearly one of the best mathematics students observed in this research study, if not the best. He seemed to retain more than other students and could put mathematical ideas and concepts into his own words better than any other observed student. On one occasion, he realized even before the instructor did that the instructor had graphed the wrong graph because of a calculator input error. He was among the best

of the students at recognizing when he made either a logic or calculation error, and on several occasions was commended by the instructor for asking penetrating questions.

Of course, it would be naïve to believe that the tables Quentin used made him into an outstanding student. It was no doubt the mathematical environment under which he was groomed that created his excellent mathematical disposition. I have since met Quentin's high school mathematics teacher, and I can honestly say that I have never encountered a high school mathematics teacher with such a unique combination of thoughtfulness, passion, and content knowledge as he possesses. It is clear that his influence must be counted as the primary reason why Quentin is such a phenomenal student.

Postscript:

In his most recent semester of teaching, this researcher met another student who used paper mathematical tables just as Quentin did. She, like, Quentin, was an outstanding mathematics student and was extremely successful academically overall. It was discovered during a conversation with this student that it was revealed that she and Quentin both attended the same high school, and had the same mathematics instructor for the last three years of their high school careers, who had instilled in them an almost reverential attitude toward their mathematical tables. If the writer is permitted an editorial comment, I think it is anecdotes like these that really demonstrate that it is not

the textbook, the mathematics curriculum, the new math program, or anything else that makes for a good mathematics classroom. It is the teacher. It has been said that the plural of anecdote is not data. While it may be heresy to say so, perhaps it is better said that the plural of anecdote is not *necessarily* data. These two students, their high school teacher, and their stories, are extraordinarily powerful and have made this researcher think about technology much more deeply than I suspect he would have if he had not met them. Stories which make you think may be the most compelling data of all.

Appendix H: An Unreported Creative Use

The student was trying to find the function $y = Pe^{rt}$ given a certain data set. He could not recall the procedure to do so, so he decided that if he could put the function in the form $y = Pb^x$, he could convert this to the function $y = Pe^{rt}$. Using two of the data points, he created a system of two equations in P and b . He used the calculator to find P to be 1000 and b to be 1.2 and found the function to be $y = 1000[1.2^x]$. He then used the calculator to graph $y = e^x$ and $y = 2$ and found then an x value of 0.1823 would make $e^{0.1823}$ approximately equal to 1.2. He then found the desired function to be $y = 1000e^{0.1823t}$. I was very impressed with the extremely imaginative use of the calculator and made special note to see if this student would later recall this use. Several weeks later this same student, when asked about his calculator usage, did not recall this instance, and overall reported that his calculator was not all that useful in helping him in the class.

VITA

Andrew Grzadzielewski

EDUCATION

University of Wisconsin – Stevens Point
B.S., Mathematics, 1985

University of Wisconsin – Oshkosh
M.S., Mathematics Education, 1996

University of Washington – Seattle
Ph.D., Mathematics Education, 2005

PROFESSIONAL EXPERIENCE

Assistant Professor of Mathematics, University of Dubuque, 2004 to present

- Taught Quantitative Reasoning, College Algebra, and Discrete Mathematics

Assistant Professor of Mathematics, University of Wisconsin - Marshfield, 2000 to 2002

- Taught College Algebra, Trigonometry, Pre-Calculus and Calculus, and Mathematics for Prospective Elementary School Teachers. Worked with Network Administrator in preparing new computer labs to serve the needs of the mathematics faculty

Teaching Assistant, University of Washington, Seattle, WA, 1998 to 2000

- Tutored in and managed the mathematics tutoring program in the undergraduate dormitories. Hired and evaluated tutors, and evaluated the program for the Mathematics Department. Also supported the Computer Lab and users in the College of Education, and taught Computer Applications to the College of Education faculty and students

Network Administrator and Corporate Trainer, Network Solutions, Wausau, WI, 1996 to 1998

- Responsible for maintaining computer networks and providing training needs for hundreds of both internal and external customers

Network Administrator and Corporate Trainer, Woodward Governor Co., Stevens Point, WI, 1990 to 1995

- Responsible for creating and maintaining a 200-node network and training new and existing users

Mathematics Teacher, Granton Area Schools, Granton, WI, 1985 to 1990

- Taught Algebra, Geometry, Pre-Calculus and Calculus. Designed and maintained multiple computer labs for use in the preparing and delivering the mathematics curriculum

PROFESSIONAL PRESENTATIONS

The Connection between Stirling Numbers of the Second Kind and Sums of Powers of Integers. Presentation to the Mathematics Faculty, University of Wisconsin Oshkosh, November 1995

Orthogonalization of Matrices using Microsoft Excel. Presentation to the Mathematics Faculty, University of Wisconsin – Stevens Point, March 1996

The History of PI. Presentation to the University of Washington Undergraduate Math Club, April 1999

Student's Understanding of the Tangent Line Approximation. Presentation to the Mathematics Faculty, University of Washington, December 1999

The Role of Calculators in an Undergraduate Calculus Classroom. Presentation to the College of Education Faculty, University of Washington, May 2000

Alternative Assessment Options in Undergraduate Mathematics Classrooms. Presentation to the Mathematics Faculty, University of Washington, March 2001

An Alternative Approach to the Solution of Exponential Equations. Presentation to the Wisconsin Mathematical Association of Two-Year Colleges, Sept 2002

Student Retention of Pre-Calculus Concepts in the Two-Year Colleges. Presentation to the Wisconsin Mathematical Association of Two-Year Colleges, Sept 2003

Implications for Pedagogy and Assessment in Classrooms Utilizing Graphing Calculator Technology. Presentation to the Wisconsin Mathematical Association of Two-Year Colleges, Sept 2004

TEACHING AND RESEARCH INTERESTS

My primary research interest currently is the role of technology in high school and undergraduate mathematics classrooms. These technologies include graphical calculators, computer algebra systems, intelligent tutoring systems and spreadsheets. I am also interested in assessment practices, especially how such practices measure long-term retention of mathematical skills and understandings.

PROFESSIONAL AFFILIATIONS

National Council of Teacher of Mathematics
Phi Delta Kappa
Wisconsin Mathematical Association of Two-Year Colleges
Mathematical Association of America