

©Copyright 2012
Sweta Suryanarayan

Local cohomology at generic singularities of Schubert varieties
in cominuscule flag varieties

Sweta Suryanarayan

A dissertation
submitted in partial fulfillment of the
requirements for the degree of

Doctor of Philosophy

University of Washington

2012

Reading Committee:

Stephen A. Mitchell, Chair

William M. McGovern

Sara C. Billey

Program Authorized to Offer Degree:
Department of Mathematics

University of Washington

Abstract

Local cohomology at generic singularities of Schubert varieties in cominuscule flag varieties

Sweta Suryanarayan

Chair of the Supervisory Committee:

Professor Stephen A. Mitchell

Department of Mathematics

We study the local cohomology of a Schubert variety in a co-minuscule flag variety at a generic singularity. Let G be a reductive complex algebraic group with a Borel subgroup B , let W be the Weyl group of G with a set of coxeter generators S and let P be a maximal parabolic subgroup of G corresponding to the set $S - \{s\}$, where s is a co-minuscule node. Let X_w be a Schubert variety in co-minuscule flag variety G/P with a generic singularity \bar{v} , where v, w are minimal coset representatives in $W/W_{S-\{s\}}$ and \bar{v} is vP/P . We develop a process to compute the local cohomology of X_w at \bar{v} , $H^*(X_w, X_w - \bar{v})$, with respect to integer coefficients and examine whether or not $H^*(X_w, X_w - \bar{v})$ has torsion.

We consider the Richardson variety R_{vw} , the intersection of X_w with the opposite Schubert variety X_v^- . Further, we introduce the concept of *Thom variety*, a Schubert variety that is also the Thom space of a line bundle over a flag variety. Reformulating results due to Brion-Polo, we show that, barring the case when we consider a Schubert variety in co-minuscule flag variety of type C_l/A_{l-1} with a generic singularity of a certain exceptional type, for each R_{vw} there is a flag variety M such that R_{vw} can be identified with a Thom variety $T(\xi)$, where ξ is a special line bundle over M . The singularity \bar{v} of R_{vw} corresponds to the point at infinity in $T(\xi)$. We prove a theorem

that identifies all the possible types of flag varieties M that correspond to R_{vw} and also determine that $H^*(X_w, X_w - \bar{v})$ is just the suspension of $H^*(T(\xi), T(\xi) - \infty)$.

We compute $H^*(T(\xi), T(\xi) - \infty)$ for each possible flag varieties M using the *node-firing game*, a variant of Mozes' number-game. Using these computations we prove that $H^*(X_w, X_w - \bar{v})$ is torsion-free when flag variety G/P is simply-laced and has 2-torsion when G/P is of type B_l/B_{l-1} .

TABLE OF CONTENTS

	Page
List of Figures	iii
List of Tables	iv
Chapter 1: Introduction	1
Chapter 2: Preliminaries	6
2.1 Abstract Root System	6
2.2 Weyl group	8
2.3 Weights	12
2.4 Classification of root systems	13
2.5 Root System of a semi-simple algebraic group	14
2.6 Parabolic subgroup	17
2.7 Flag Varieties	18
2.8 Richardson Variety	19
2.9 Co-minuscule flag variety	20
Chapter 3: The Node-firing game and co-minuscule flag variety	23
3.1 Bruhat poset (W^I, \leq) for co-minuscule W^I	23
3.2 The Node Firing Game	27
Chapter 4: Thom Variety	34
4.1 Parabolic orbits in flag varieties	34
4.2 Thom Variety	39
Chapter 5: Local cohomology of Schubert varieties at a generic singularities and Thom varieties	42
5.1 Local cohomology	42

5.2	Local cohomology of a Schubert variety at a generic singularity	43
Chapter 6:	Richardson variety as Thom variety in Co-minuscule flag varieties	46
6.1	Minimal degeneration and Richardson variety as Thom variety	46
6.2	Richardson variety in a co-minuscule flag variety	48
Chapter 7:	Computing local cohomology at generic singularities for Schubert varieties in Co-minuscule flag varieties	56
7.1	Notations	56
7.2	Cohomology of $\mathcal{O}_s - M_s$ and the flag variety M_s	57
7.3	Co-minuscule M_s and the map $H^{n-2}(M_s) \xrightarrow{c_1(\xi_s)} H^n(M_s)$	60
7.4	Computing $H^*(\mathcal{O}_s - M_s)$ when M_s is co-minuscule	63
7.5	Computing $H^*(\mathcal{O}_s - M_s)$ when M_s is of type $(A_{k-1}/A_{k-2}) \times (A_{l-k}/A_{l-k-1})$ for $1 < k < l$	73
7.6	Computing local cohomology $H_v^*(X_w)$	74
Chapter 8:	Local cohomology at the point at infinity of Thom varieties over a co-minuscule flag variety	76
8.1	Computing $H^*(\mathcal{O}_s - M_s)$ for co-minuscule M_s	76
8.2	Local cohomology of Thom variety at the point at infinity when M_s is minuscule	87
8.3	Observations: Torsion in local cohomology	88
Bibliography	89

LIST OF FIGURES

Figure Number	Page
2.1 Dynkin Diagrams	15
3.1 Hasse Diagram (W^I, \leq) of type $A_3/(A_1 \times A_1)$	24
3.2 Node-firing game for ω_2^\vee in A_3	31
7.1 Node-firing game on ω_1^\vee in D_4	64
7.2 Node-firing game on ω_5^\vee in D_5	65
7.3 Node-firing game on ω_6^\vee in E_6	67
7.4 Node-firing game on ω_1^\vee in D_l	68
7.5 Step $l - 1$ of node-firing game on ω_2^\vee in A_3 when l is even	70
7.6 Step $l - 1$ of node-firing game on ω_2^\vee in A_3 when l is odd	70
7.7 Node-firing game on ω_1^\vee in C_l	72
8.1 Node-firing game on ω_7^\vee in E_7	78
8.2 Python program for computing kernel and cokernel of \mathcal{M}_i for all i (part 1/2)	81
8.2 Python program for computing kernel and cokernel of \mathcal{M}_i for all i (part 2/2).	82
8.3 Python program: Co-weight position ω_l^\vee for D_l/A_{l-1}	83
8.4 Python program: Run for D_5/A_4	83
8.5 Python program: Co-weight position ω_l^\vee for C_l/A_{l-1}	84
8.6 Python program: Run for C_3/A_2	85
8.7 Python program: Co-weight position ω_3^\vee for $A_l/(A_2 \times A_{l-3})$	86
8.8 Python program: Run for $A_5/(A_2 \times A_2)$	86

LIST OF TABLES

Table Number	Page
7.1 Typical descent graph (Γ_D, s) with corresponding flag variety M_s for which $T(\xi_s)$ is isomorphic to R_{vw}	59

ACKNOWLEDGMENTS

It is a pleasure to thank the many people who made this dissertation possible and because of whom my graduate experience has been one that I will cherish forever.

I am deeply grateful to my advisor, Steve Mitchell, without whose guidance none of this work would have been possible. I would like to thank him for his patience, support and encouragement throughout my graduate studies.

I would like to express my heart-felt gratitude to my parents, Bhavani and Suryanarayan for their never-ending moral and spiritual support, and for always encouraging me to follow my heart.

I would like thank my brother, Bhaskaran, for being a constant source of love and strength all my life and for always believing in my capabilities.

I extremely grateful to my husband, Ajay, for being my pillar of strength and without whose unwavering love and encouragement it would have been impossible for me to finish this work.

I am grateful to my extended family who have encouraged me throughout this endeavor. My many thanks Ajay's parents Vimala and Shankar and my sister-in-law Sharada.

I owe special thanks to my aunts Radha and Lalita for helping me adjust to a new country when I started my graduate studies at University of Washington and also for their constant moral support through the years.

I am grateful to all my friends whose support and care helped me stay happy and focused on my graduate study.

Finally, I would also like to thank the Department of Mathematics at University

of Washington Seattle for giving me the wonderful opportunity and warm atmosphere to pursue my interests.

DEDICATION

to my dear grandmother, Subbulakshmi Rajaraman

Chapter 1

INTRODUCTION

The main aim of this thesis is to understand the local cohomology at generic singularities of Schubert varieties in co-minuscule flag varieties. In order to put our problem and results in context we begin with a discussion of the general problem. Let X_w be a Schubert variety in a flag variety G/P . There are the following fundamental questions:

- (a) When is X_w smooth ?
- (b) More generally, what is the smooth locus of X_w ?
- (c) What kind of singularities does X_w have ?

There is vast literature on singularities of Schubert varieties which deal with (a) and (b) (see [1] for background). For example, if \bar{v} is a smooth point of X_w , where X_w is of complex dimension n , then

$$H^i(X_w, X_w - \bar{v}) \cong H^i(\mathbb{C}, \mathbb{C} - 0) = \begin{cases} \mathbb{Z} & \text{for } i = 2n \\ 0 & \text{otherwise.} \end{cases}$$

Further, the variety X_w is said to be rationally smooth at \bar{v} if the isomorphism above holds with rational coefficients, i.e. after tensoring with \mathbb{Q} . The problem of rational smoothness also has an extensive literature (again see [1]). A theorem of Dale Peterson (see [7]) shows that for Schubert varieties in simply-laced flag varieties of type ADE, rationally smooth implies smooth. The analogous result for affine Grassmannians holds only in types DE (see [2]).

We are mainly interested in understanding the question (c) by studying the local topology of a Schubert variety X_w at a singular point \bar{v} . In particular, there is the following interesting problem:

Problem: What can one say about the local cohomology $H^(X_w, X_w - \bar{v})$?*

Here the cohomology referred to is the integral cohomology. This general problem is hopelessly difficult if considered as stated, so in this thesis we find specific constraints using the work of Brion-Polo in [5], which make this problem more accessible. We focus exclusively on *generic singularities* of X_w and consider the problem of finding the local cohomology $H^*(X_w, X_w - \bar{v})$ when X_w is a Schubert variety of a *co-minuscule flag variety*. We summarize our work below.

In chapter 2, we introduce basic definitions, notations and results from topics such as root system, Weyl group, weights, root system of a semi-simple algebraic group, parabolic subgroup, flag varieties, co-minuscule flag variety, Schubert varieties and Richardson varieties.

In chapter 3, we describe the node-firing game studied in [9], which is a version of Eriksson's number game (See [10], [11]). This game was originally formulated by Mozes (See [23]). We focus mainly on the results of playing the node-firing game played on a fundamental co-weight ω_a^\vee . This gives us a process of constructing the lattice $(W \cdot \omega_a^\vee, \preceq_r)$, where W is the corresponding Weyl group and \preceq_r is a specified partial order on the co-weights. It also gives us the values of $\sigma\omega_a^\vee(\alpha)$ for each σ from the set of minimal coset representatives $W^{[s_a]}$ and simple root α . This game is used in chapter 6 for identifying generic singularities and for computation of local cohomology in chapter 7.

In chapter 4, we introduce the concept of *Thom variety* which is a Schubert variety that is also a Thom space of a line bundle over a smaller flag variety M . In

geometry Thom varieties are known as projective cones but we want to emphasize the topology. We then recall a well known result that the minimal non-trivial *parabolic orbit* \mathcal{O} formed by the left P -action on the flag variety G/P where P is a maximal parabolic subgroup of G is isomorphic as a variety to a line bundle ξ over a smaller flag variety $M = L/Q$. Then it turns out that $T(\xi)$ is a Thom variety. In fact, Thom variety $T(\xi_s)$ is a Schubert variety with the point at infinity as a possible generic singularity (not true in all cases; e.g. type A_l/A_{l-1})

In chapter 5, we start with a Schubert variety X_w with a generic singularity \bar{v} . Since \bar{v} as a singularity of a Schubert variety is smoothly equivalent to \bar{v} as a singularity of the corresponding Richardson variety, we determine the relation that the local cohomology at \bar{v} of X_w is just a suspension of the local cohomology at \bar{v} of $R_{v,w}$. That is,

$$H_{\bar{v}}^*(X_w) \cong H_{\bar{v}}^{*-2m}(R_{v,w}).$$

We consider the local cohomology at the point at infinity of a Thom variety $T(\xi)$, considered as a Schubert variety and derive the following.

$$H_{\infty}^*(T(\xi)) \cong H^{*-1}(\mathcal{O} - M).$$

Inspired by Juteau's work in [18] where he computes the cohomology of minimal nilpotent orbits we derive the following result.

Theorem 1.0.1. Let the map $H^*(M) \xrightarrow{c_1(\xi)} H^{*+2}(M)$ denote the cup product with $c_1(\xi)$ where $c_1(\xi) \in H^2(M)$ is the first Chern class of ξ . Then we have the following relations.

$$H^n(\mathcal{O} - M) \simeq \begin{cases} \text{Coker}(H^{n-2}(M) \xrightarrow{c_1(\xi)} H^n(M)) & \text{if } n \text{ is even.} \\ \text{Ker}(H^{n-1}(M) \xrightarrow{c_1(\xi)} H^{n+1}(M)) & \text{if } n \text{ is odd.} \end{cases}$$

Hence in the case when the Richardson variety R_{vw} is also a Thom variety $T(\xi)$, with \bar{v} corresponding to the point at infinity in $T(\xi)$, we can rewrite the local cohomology at \bar{v} of R_{vw} in terms of the cohomology of the total space \mathcal{O} minus the zero section. That is,

$$H^*(R_{vw}, R_{vw} - \bar{v}) \cong H^{*-1}(\mathcal{O} - M).$$

Therefore our problem simplifies it into answering the following. Let X_w be a Schubert variety with a generic singularity \bar{v} .

- (1) Under what conditions can we say that the Richardson variety R_{vw} is a Thom variety?
- (2) Under the conditions (from (1)) that R_{vw} is a Thom variety, how can we further simplify and compute $H^*(\mathcal{O} - L/Q)$?

In Chapter 6, we derive an answer for question (1) by re-formulating Brion-Polo's work in [5]. First we consider a Schubert variety X_w in any flag variety with a point \bar{v} such that the corresponding $v \in W$ is a minimal degeneration of w . Then in Proposition 6.1.4 we give sufficient conditions which generate a Thom variety $T(\xi)$ such that the Richardson variety R_{vw} is equal to $T(\xi)$ and the point \bar{v} corresponds to the point at infinity of $T(\xi)$. We then show in Lemma 6.2.1 that for a Schubert variety in a co-minuscule flag varieties \bar{v} in X_w is a generic singularity if and only if v minimal degeneration of w . Finally, in Theorem 6.2.9 we show that for a Schubert variety X_w in any co-minuscule flag variety except for the type C_l/A_{l-1} we can identify $R_{v,w}$ with a Thom variety.

In Chapter 7, we consider a Richardson varieties R_{vw} with generic singularity \bar{v} in a co-minuscule flag variety except for the type C_l/A_{l-1} . Then there is a line bundle ξ with a base space M such that $T(\xi) = R_{vw}$. Since the main aim of this paper

is to understand the local cohomology at the generic singularities of Schubert varieties in co-minuscule flag varieties, we are interested in computing $H^*(\mathcal{O} - M)$ and also particularly interested in the appearance of torsion in the cohomology. As we will see (following [5]), the auxiliary flag varieties M which can occur are severely restricted, making the problem accessible. Hence we identify the types of all such flag varieties M (see Theorem 7.2.1). All the possible flag varieties M turn out to be of co-minuscule type except for one simple exceptional case. We describe a process of using the node-firing game from Chapter 3 on the co-minuscule co-weight corresponding to co-minuscule M , which helps find the matrices representing each map $c_1(\xi) : (H^{2i-2}(M) \rightarrow H^{2i}(M))$. Finally, by a case-by-case analysis we compute $H^*(\mathcal{O} - M)$ for each possible M .

This raises the more general question of computing the local cohomology at the point at infinity of Thom varieties over any co-minuscule M . We consider this question in chapter 8 by looking at $H^*(\mathcal{O} - M)$ for all the co-minuscule M that haven't been considered in Chapter 7. In the computation of $H^*(\mathcal{O} - M)$ for M of type B_l/B_{l-1} and E_7/E_6 we see that 2-torsion appears. Also for M of type $A_l/(A_k \times A_{l-k-1})$ for $2 \leq k \leq l-2$, C_l/A_{l-1} for $l \geq 3$ and D_l/A_{l-1} for $l \geq 6$, we compute $H^*(\mathcal{O} - M)$ for some initial values of l . We again observe the presence of 2-torsion in the local cohomology. For some higher values of l we also see the appearance of odd torsion in some cases. The presence of p -torsion in local cohomology raises the question that given the usual line bundle ξ over a co-minuscule flag variety M_s , is there a condition that gives us the prime p such that p -torsion appears in $H_\infty^*(T(\xi))$. We will leave the investigation of the presence of p -torsion to future work.

Chapter 2

PRELIMINARIES

In this chapter we review essential definitions and results, and fix notations. The main references for this Chapter are [16], [4], [6], [20] and [1].

2.1 Abstract Root System

Let V be a finite-dimensional vector space with a non-degenerate inner product (\cdot, \cdot) .

2.1.1 Reflection with respect to a vector

Given a non-zero vector $\alpha \in V$ we define the *reflection* s_α to be the linear transformation s_α on V given by

$$s_\alpha(v) = v - 2 \frac{(v, \alpha)}{(\alpha, \alpha)} \alpha.$$

Denote the vector $\frac{2}{(\alpha, \alpha)} \alpha$ by α^\vee then we can also write

$$s_\alpha(v) = v - (v, \alpha^\vee) \alpha.$$

Remark 2.1.1. The reflections preserve the inner product on V .

2.1.2 Root system

A *root system* of a vector space V is defined to be a set of vectors Φ in V such that

1. Φ spans V and $0 \notin \Phi$.
2. If $\alpha \in \Phi$ then the only multiples of α in Φ are $\pm\alpha$.
3. $s_\alpha \Phi = \Phi$ for all $\alpha \in \Phi$.

4. (β, α^\vee) is an integer for any $\alpha, \beta \in \Phi$ (See [16], §1.2).

2.1.3 Positive and Negative root system

Given a total ordering $<_T$ on V , we say that $\lambda \in V$ is *positive* if $0 <_T \lambda$. Since roots in Φ come in pairs $\{\alpha, -\alpha\}$ we can partition Φ into *positive system of roots* Φ^+ and *negative system of roots* Φ^- . For example we can construct a total ordering corresponding to lexicographic ordering. Let $\dim(V) = l$, which is also called the *rank of Φ* . Pick a basis $\{\lambda_1, \lambda_2, \dots, \lambda_l\}$ of V . Then

$$\sum a_i \lambda_i <_T \sum b_i \lambda_i \text{ if } a_k < b_k \text{ for the least index } i \text{ such that } a_i \neq b_i$$

Note that all the basis elements λ_i are then positive by definition.

2.1.4 Simple system

A subset $\Delta = \{\alpha_1, \alpha_2, \dots, \alpha_l\}$ of Φ is called a *simple system* if

1. Δ is a basis of V .
2. For any $\alpha \in \Phi$, we can write $\alpha = \sum c_i \alpha_i$ such that all the coefficients c_i are integers with the same sign.

Note that all roots in Δ are positive and are called *simple roots*.

Theorem 2.1.2. In a root system, given a positive Φ^+ there exists a unique simple system Δ such that $\Delta \subseteq \Phi^+$. The converse is also true. (See [16], Pg 8)

2.1.5 Dual root system

The vector α^\vee described earlier is called the *coroot* of α . The set of all coroots $\Phi^\vee = \{\alpha^\vee : \alpha \in \Phi\}$ is also a root system in V , known as the *dual root system*. We define a simple system in Φ^\vee by $\Delta^\vee = \{\alpha^\vee : \alpha \in \Delta\}$. Note that $(\alpha^\vee)^\vee = \alpha$.

2.1.6 Irreducible root system

A root system is said to be *reducible* if it can be partitioned into two sub-root systems such that vector sub-spaces of V that correspond to the sub-root systems are orthogonal spaces; otherwise the root system is said to be *irreducible*.

2.1.7 Highest root

Given a fixed simple system Δ for a root system Φ there is natural partial ordering \preceq on V defined as $\mu \preceq \nu$ if and only if $\nu - \mu$ is a sum of positive roots. There is a unique maximal root $\tilde{\alpha} \in \Phi$ relative to the partial order given above called the *highest root* (see [17], §10.4 Lemma A).

Remark 2.1.3. Set \preceq_r to be the another partial order on V given by $\nu \preceq_r \mu$ if and only if $\mu \preceq \nu$. This will useful in some later reference.

2.2 Weyl group

Let V be a finite-dimensional vector space.

2.2.1 Weyl group

Given a root system Φ in V , let R be the set of all corresponding reflections, that is $R = \{s_\alpha : \alpha \in \Phi\}$. Define the *Weyl group* W corresponding to Φ to be the subgroup of the group of inner product preserving transformations on V generated by the R . It turns out R contains every reflection in W (See [16], Pg 24). W is also a subgroup of the permutation group on the vectors in Φ by property of root systems, hence it is finite. If Δ is a simple system of Φ then the elements of the set $S = \{s_\alpha : \alpha \in \Delta\}$ are called *simple reflections* in W . In fact, S is a generating set of W (See [16], Pg 11). For convenience, we will sometime denote $s_{\alpha_i} \in S$ by s_i .

2.2.2 Coxeter System presentation of Weyl group

For any $\alpha, \beta \in \Phi$, let $m(\alpha, \beta)$ be the order of $s_\alpha s_\beta$ in the Weyl group W . Then W has following presentation.

$$W = \langle s_{\alpha_i} \in S : (s_{\alpha_i} s_{\alpha_j})^{m(\alpha_i, \alpha_j)} = 1 \quad \forall \alpha_j \in \Delta \rangle \quad (\text{see [16] Theorem 1.9})$$

Hence (W, S) is a Coxeter System (See [4] §1.3).

Proposition 2.2.1. For any $\alpha, \beta \in \Phi$ such that $\alpha \neq \beta$ we have that $m(\alpha, \beta) \in \{2, 3, 4, 6\}$. (See [16], §2.9)

2.2.3 Coxeter graph and Coxeter matrix of (W, S)

We can represent a Coxeter system (W, S) by labeled graph Γ as follows.

1. The simple system $\Delta = \{\alpha_1, \dots, \alpha_l\}$ corresponding to (W, S) forms the vertex set of Γ .
2. Vertices α_i, α_j for $i \neq j$ are joined by an edge whenever $m(\alpha_i, \alpha_j) \geq 3$ and the edge is labeled with $m(\alpha_i, \alpha_j)$.

We can also represent (W, S) by a square matrix $\mathcal{M}_\Gamma = [m(\alpha_i, \alpha_j)]_{\alpha_i, \alpha_j \in \Delta}$. Hence Γ and \mathcal{M}_Γ are the Coxeter graph and Coxeter matrix representation of (W, S) respectively. (See [4], IV, §1.9)

Remark 2.2.2. If two vertices α_i, α_j are not joined by an edge it means $m(s_{\alpha_i}, s_{\alpha_j}) = 2$ which implies $s_{\alpha_i}, s_{\alpha_j}$ commute.

Remark 2.2.3. The vertex set of a Coxeter graph is can also be represented by either set of Coxeter generators $S = \{s_1, \dots, s_l\}$ or just the index set $I = \{1, \dots, l\}$.

2.2.4 Length function on a Weyl group

We know that for any $w \in W$, we have the expression $w = s_1 \cdots s_r$ for some $s_i \in S$. If r is the smallest value for which such an expression of w exists then $s_1 \cdots s_r$ is called a *reduced expression* of w . Then *length* of w , denoted by $l(w)$, is equal to r . For example, for $s_\alpha \in \Delta$, $l(s_\alpha) = 1$.

Remark 2.2.4. There exists a unique maximal length element w_0 in W .

2.2.5 Partial order on a Weyl group

Recall R is the set of all reflections in W .

Bruhat order

Let $w, w' \in W$. Then

- $w \uparrow w'$ denotes that there exists $s' \in R$ such that $w' = ws'$ and $l(w) < l(w')$ then .
- $w \leq w'$ denotes that there exists $w_1, \dots, w_m \in W$ such that $w \uparrow w_1 \uparrow \dots \uparrow w_m \uparrow w'$. This defines a partial order on W called the *Bruhat order*.

A Bruhat poset (W, \leq) denotes W as a partially ordered set relative to Bruhat order.

Remark 2.2.5. For any $w, w' \in W$, $w \leq w'$ if there is a reduced decomposition of w' from which a reduced decomposition of w can be obtained by simply deleting some of the factors.

Remark 2.2.6. For $w, w' \in W$, $w \uparrow w'$ if and only if there exists $s'' \in R$ such that $w' = s''w$. Using the notations given above, in fact $s'' = ws'w^{-1}$.

Remark 2.2.7. For $w, w' \in W$ such that $w \leq w'$ the set $\{v \in W : w \leq v \leq w'\}$ is called a *Bruhat interval* denoted by $[w, w']$.

Left weak order

Let $w, w' \in W$. Then $w \leq_L w'$ denotes that there exists $s_1, \dots, s_r \in S$ such that $w' = s_1 \cdots s_r w$ and $l(s_1 \cdots s_i w) = l(w) + i$ for all $1 \leq i \leq r$. This defines a partial order on W which is called the *left weak order*.

Remark 2.2.8. For $w, w' \in W$, $w \leq_L w'$ implies $w \leq w'$.

2.2.6 Parabolic subgroup of a Weyl group

Let I be any arbitrary subset of S then the subgroup W_I of W generated by I is called a *parabolic subgroup* of W . For example, $W_\emptyset = 1$ and $W_S = W$. Now let $\Delta_I = \{\alpha \in \Delta : s_\alpha \in I\}$ and let Φ_I be the span of Δ_I in Φ . Then Φ_I is also a root system in V with Δ_I as the corresponding simple system and W_I as the corresponding Weyl group.

Proposition 2.2.9. Let Γ be the Coxeter graph corresponding to the Coxeter system (W, S) . Let $\Gamma_1, \dots, \Gamma_r$ be the connected components of Γ . Then for each Γ_i we have the corresponding subsets S_i of S . Now let W_{S_i} be the parabolic subgroup generated by S_i . Then W is the direct product of subgroups W_{S_1}, \dots, W_{S_r} , and each Coxeter system (W_{S_i}, S_i) is irreducible. (Proposition 2.2, [16])

2.2.7 Minimal coset representatives

Let W_I be a parabolic subgroup of W for some $I \subseteq S$. Let $W^I = \{w \in W : l(ws) > l(w) \text{ for all } s \in I\}$. Then from [16] (Pg 19, Proposition (c)) we have the following.

Proposition 2.2.10. For any $w \in W$, there exists unique $w^I \in W^I$ and $v \in W_I$ such that $w = w^I v$ and $l(w) = l(w^I) + l(v)$.

Thus $w^I \in W$ is the unique element of the smallest length in the coset wW_I . Clearly, $w^I W_I = wW_I$.

Remark 2.2.11. There is a bijective correspondence between cosets of W/W_I and W^I ($wW_I \leftrightarrow w^I$).

Hence we call w^I the *minimal coset representative* of wW_I . By abuse of notation we represent the coset wW_I in W/W_I by just w . We define a length function l^I on W/W_I as follows: For $w \in W/W_I$, $l^I(w) = l(w^I)$.

Remark 2.2.12. The Bruhat order and the left weak order on W^I are the partial orders on W^I formed by the restriction of Bruhat order and left weak order on W to W^I .

2.2.8 Minimal double coset representatives

Let I, J be subsets of S . The double cosets $W_I \backslash W / W_J$ are the W_I orbits obtained by the left W_I action on cosets W / W_J . Then we have the following.

Proposition 1. Given a double coset $W_I w W_J$ for some $w \in W$, there is a unique element w^{IJ} in it of minimal length. That is, w^{IJ} is the minimal length representative of $W_I w W_J$. (See [12] Proposition 2.1.7)

Proposition 2. Consider a double coset $W_I w W_J$ such that w is the minimal length element in the coset. Let K_w be a subset of I defined as $K_w = \{s \in I : w^{-1} s w \in J\}$. Then the isotropy group of wW_J in W_I by the left action is a parabolic subgroup of the form W_{K_w} .

Remark 2.2.13. From Proposition 2 we have a bijection between $(W_I)^{K_w}$ and $W_I w W_J / W_J$ where $\nu \in (W_I)^{K_w}$ corresponds to the element $\nu w \in W_I w W_J / W_J$

2.3 Weights

Let V be a finite-dimensional vector space with a non-degenerate inner product (\cdot, \cdot) . We will continue using the notations introduced in Section 2.1.

2.3.1 Weight and co-weights

If λ is a vector in V such that $(\lambda, \alpha^\vee) \in \mathbb{Z}$ for all $\alpha \in \Phi$ then λ is called a *weight*. If λ is a vector in V such that $(\lambda, \alpha) \in \mathbb{Z}$ for all $\alpha \in \Phi$ then λ is called a *coweight*. The *weight lattice*, denoted by $P(\Phi)$, is the set of all weights and similarly the *coweight lattice*, denoted by $P(\Phi^\vee)$, is the set of all co-weights.

Remark 2.3.1. Any weight λ can also be represented as an integer function on Φ^\vee by setting $\lambda(\alpha^\vee) = (\lambda, \alpha^\vee)$

2.3.2 Fundamental weights

Let $\Delta = \{\alpha_1, \dots, \alpha_l\}$ be a simple system corresponding to root system Φ . Then the set $\{\omega_1, \dots, \omega_l | \omega_i(\alpha_j^\vee) = \delta_{ij}\}$ forms a basis of $P(\Phi)$ and the weights in this basis are called the *fundamental weights*. Similarly the set $\{\omega_1^\vee, \dots, \omega_l^\vee | \omega_i^\vee(\alpha_j) = \delta_{ij}\}$ forms a basis of $P(\Phi^\vee)$ and the co-weights in this basis are called the *fundamental co-weights*.

2.3.3 Dominant weight

A weight λ is said to be a *dominant weight* if $\lambda = \sum c_i \omega_i$ such that $c_i \in \mathbb{Z}^+$ for all $i = 1, \dots, l$.

2.4 Classification of root systems

Let Φ be a root system in a vector space V with a non-degenerate inner product (\cdot, \cdot) . Then the length of a root $\alpha \in \Phi$ is $(\alpha, \alpha)^{1/2}$. If all roots in Φ are of the same length then Φ is said to be *simply laced*. If Φ was irreducible then we have the following. (See [16], [17]).

- There are at most two possible lengths for the roots in Φ .
- If Φ has roots of two different lengths then the ratio of the squared lengths of the long root to the short root can be 2 or 3. If $\alpha, \beta \in \Delta$ such that α is a longer

root than β then the ratio is 2 if and only if $m(\alpha, \beta) = 4$ and the ratio is 3 if and only if $m(\alpha, \beta) = 6$.

2.4.1 Dynkin Diagrams

A Dynkin diagram corresponding to a root system Φ is the Coxeter graph Γ of the corresponding Coxeter system (W, S) along with additional information about the lengths of the simple roots (vertices). We can construct the Dynkin diagram of an irreducible root system Φ as follows.

1. Construct the Coxeter graph for the corresponding Coxeter system (W, S) .
2. Replace label 3, 4 or 6 on an edge by a single edge, double edge or triple edge respectively.
3. If adjacent vertices in the graph represent are of different lengths then add a directing arrow towards the short root on the edge between the two vertices.

Now suppose we have a reducible root system Φ which can be partitioned into a family irreducible root systems $(\Phi_i)_{i \in \mathcal{I}}$. Then using proposition 2.2.9 the Dynkin diagrams of each Φ_i as constructed above form all the connected components of the Dynkin diagram of root system Φ (See [4], §1.2).

Theorem 2.4.1. If Φ is an irreducible root system, then the Dynkin diagram is isomorphic to one of the diagrams given in Figure 2.1.

For a proof of this Theorem see [4] §4.2.

2.5 Root System of a semi-simple algebraic group

Let G be a semi-simple simply connected complex Lie group with Lie algebra \mathfrak{g} . Fix a Borel subgroup B in G containing a maximal torus H and a unipotent subgroup

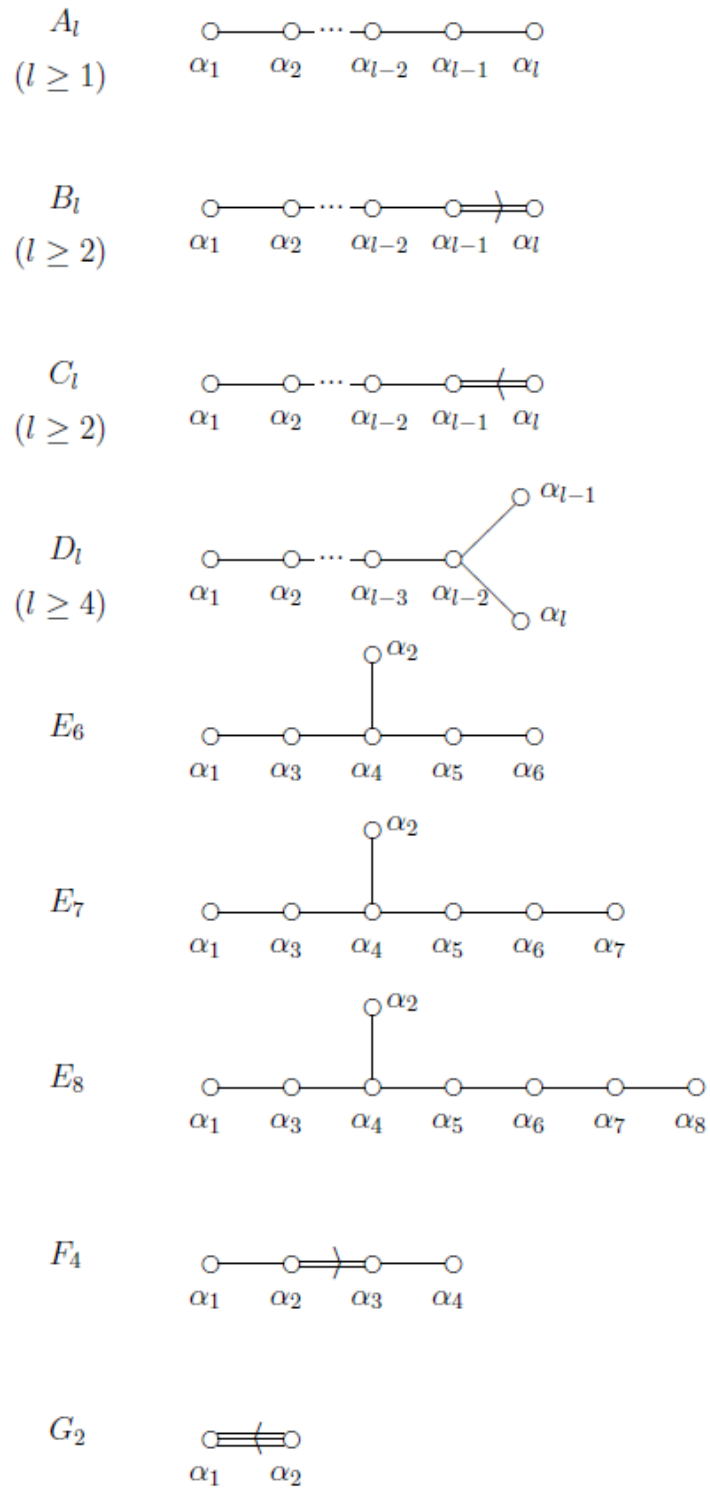

Figure 2.1: Dynkin Diagrams

U . Then $B = UH$. Now the group $W = N_G(H)/H$ is called the Weyl group of G . This related to the Weyl group defined above. In this section, we will briefly discuss the corresponding root system which is basically the collection of non-zero weights of the adjoint representation.

2.5.1 Weights and Weight space of a representation of H

Let V be a H -module. Let $\chi : T \rightarrow \mathbb{C}$ be an irreducible character such that the following set is non-zero.

$$V_\chi = \{v \in V : t \cdot v = \chi(t)v \text{ for all } t \in T\}$$

Then χ is called a *weight* of V and V_χ the corresponding *weight space*. In fact, V is a direct sum of its weight spaces, $V = \bigoplus V_\chi$. A weight vector of a weight χ is any non-zero vector in the weight space V_χ .

2.5.2 Root System of G

By the adjoint action of G on \mathfrak{g} we can describe \mathfrak{g} to be an H -module. Then we have the weight space decomposition $\mathfrak{g} = \bigoplus \mathfrak{g}_\alpha$. The set of all non-zero weights of \mathfrak{g} in the decomposition forms the root system Φ of G with respect to H .

In fact, if we let $\mathfrak{h} = \text{Lie}(H)$, then

$$\mathfrak{g} = \bigoplus_{\alpha \in \Phi} \mathfrak{g}_\alpha \text{ (see 13.18 in [3])}$$

2.5.3 Root subgroups of G

For each $\alpha \in \Phi$ there exists a unique subgroup U_α of G such that U_α is connected and T -stable with Lie algebra \mathfrak{g}_α . It is also known that the unipotent subgroup U is generated by root subgroups U_α for $\alpha \in \Phi^+$. (see [3]).

2.6 Parabolic subgroup

Let G be a semi-simple simply connected complex Lie group. We will continue using the notation in §2.5.

2.6.1 Parabolic subgroup

Any subgroup P of G that contains some Borel subgroup is called a parabolic subgroup of G . A subgroup P of G containing the fixed Borel subgroup B is called a *standard parabolic subgroup*. For any subset I of S , W_I is the parabolic subgroup of the Weyl group W corresponding to I . Then by P_I we denote a parabolic subgroup $P_I = BW_I B$ of G . We can see that P_I is a standard parabolic subgroup. Note that for any standard parabolic subgroup P that contains B , there exists a $I \subseteq S$ such that $P = P_I$. From now on whenever we mention parabolic subgroup, we mean a standard parabolic subgroup.

2.6.2 Unipotent radical and Levi subgroup of a parabolic subgroup

Let I be subset of S . Then the subgroup of unipotent elements of the radical of P_I forms the *unipotent radical of P_I* denoted by $\mathcal{R}_u(P)$. In fact, $\mathcal{R}_u(B) = U$. There is connected subgroup L_I of P_I such that P_I is a semidirect product of L_I and $\mathcal{R}_u(P)$. L_I is called the Levi subgroup of P_I . The Levi subgroup is in fact a reductive algebraic group. Now Φ_I , the sub-root system of Φ , is the root system corresponding to L_I . In fact, we can consider L_I to be the subgroup of P_I generated by H and the root subgroups U_α , $\alpha \in \Phi_I$. Let $B_I = B \cap L_I$. Then B_I is a Borel subgroup of L_I . We then have $B_I = U_I H$ such that $U_I = \mathcal{R}_u(B_I)$. Thus U_I is generated by the root subgroups U_α for $\alpha \in \Phi_I^+$ (see [3]).

2.7 Flag Varieties

Let G be a semi-simple simply connected complex Lie group. We will continue using the notations from the previous sections.

2.7.1 Flag variety

Let P_J be a parabolic subgroup for some $J \subseteq S$, then the homogeneous space G/P_J forms a *flag variety*. When $J = \emptyset$ is empty set then $G/P_J = G/B$. Now Φ is the root system corresponding to G . Let L_J be the Levi subgroup of P_J . Then the sub-root system Φ_J of the Φ is the root system of L_J . Now suppose the Dynkin diagrams corresponding to Φ and Φ_J are of some type M and N respectively (see Theorem 2.4.1) then we say that W/W_J is of type M/N . We also say that, *The flag variety of G/P_J is of type M/N .*

2.7.2 Schubert variety

The *Bruhat decomposition* states that G is a disjoint union of the double coset BwB , where $w \in W$. That is

$$G = \bigsqcup_{w \in W} BwB. \text{ (see [3])}$$

This leads to generalization and other forms of decomposition. Here is a list we will be referring to later.

- $G/B = \bigsqcup_{w \in W} B \cdot wB/B$ (Schubert cell decomposition).
- If $J \subset S$ then $G/P_J = \bigsqcup_{w \in W^I} B \cdot wP_J/P_J$ (Schubert cell decomposition).
- If $I, J \subset S$ then by the left P_I -action on flag variety G/P_J we get

$$G/P_J = \bigsqcup_{w \in W^{IJ}} P_I \cdot wP_J/P_J.$$

For any $w \in W$, we call the orbit $e_w = B \cdot wP_J/P_J$ due to left Borel action on G/P_J , a *Schubert cell* and its closure $X_w = \overline{e_w}$ a *Schubert variety*. Here are some important facts about Schubert varieties we will be using.

- $X_w = \bigcup_{v \in W^J, v \leq w} e_v$.
- The family $\{[X_w]^*\}_{w \in W^J}$ forms an additive basis of the cohomology ring $H^*(G/P_J)$ called the Schubert basis.
- For $w_1, w_2 \in W^I$, $w_1 \leq w_2 \Leftrightarrow X_{w_1} \subseteq X_{w_2}$ (Bruhat order, see [8]).

2.8 Richardson Variety

2.8.1 Opposite Borel subgroup

For the fixed Borel subgroup B of G , the Borel subgroup $B^- = w_0 B w_0$, where w_0 is the maximal length element of W , is called the *opposite Borel subgroup*. In fact, B^- is the unique Borel subgroup of G such that $B \cap B^- = H$.

2.8.2 Opposite Schubert variety

Let G/P_I be a flag variety for some $I \subset S$. With B^- we have the Bruhat decomposition

$$G/P_I = \bigsqcup_{w \in W^I} B^- \cdot wP_I/P_I.$$

Here $e_w^- = B^- \cdot wP_I/P_I$ is the *opposite Schubert cell* and correspondingly $X_w^- = \overline{e_w^-}$ is the *opposite Schubert variety*. Then we have that $X_w^- = \bigcup_{v \geq w} e_v^-$.

2.8.3 Richardson variety

Let G/P_I be a flag variety for some $I \subset S$. Pick any $v, w \in W^I$. We define a Richardson variety $R_{v,w}$ as the intersection $X_w \cap X_v^-$. Here are some important properties of Richardson varieties.

1. $X_w \cap X_v^- = \phi$ unless $v \leq w$.
2. If $v \leq w$, $\sigma P_I/P_I \in R_{v,w}$ if and only if $v \leq \sigma \leq w$.
3. $R_{v,w}$ is irreducible of $\dim(l^I(w)) - \dim(l^I(v))$.
4. If $w = v$, $R_{w,w} = wP_I/P_I$ and X_w, X_w^- intersect transversally at \bar{w} .

2.9 Co-minuscule flag variety

Let G be a semi-simple simply connected complex Lie group. We will continue using the notations from the previous sections.

2.9.1 Co-minuscule nodes

Let Φ be the corresponding root system with the simple system $\Delta = \{\alpha_1, \dots, \alpha_l\}$. We call $s_t \in S$ where $t \in \{1, \dots, N\}$ a *co-minuscule node* if it satisfies one of the following equivalent properties.

1. The coefficient of the simple root α_t in the highest root $\tilde{\alpha}$ is 1.
2. s_t is conjugate to s_0 under an automorphism of the affine diagram $\widetilde{\Gamma}_S$.

The highest root and the affine Dynkin diagram for each type of irreducible root system is given in [4]. Using this we list below the set of all co-minuscule nodes for each of type of irreducible root system (see Theorem 2.4.1).

1. In type A_l the set of co-minuscule nodes are $\{s_1, \dots, s_l\}$ where $l \geq 1$.
2. In type B_l the set of co-minuscule nodes are $\{s_1\}$ where $l \geq 2$.
3. In type C_l the set of co-minuscule nodes are $\{s_l\}$ where $l \geq 2$.
4. In type D_l the set of co-minuscule nodes are $\{s_1, s_{l-1}, s_l\}$ where $l \geq 4$.

5. In type E_6 the set of co-minuscule nodes are $\{s_1, s_6\}$.
6. In type E_7 the set of co-minuscule nodes are $\{s_7\}$.
7. In types E_8, F_4 and G_2 there are no co-minuscule nodes.

2.9.2 Co-minuscule flag variety

If $P_{[t]}$ is the maximal parabolic subgroup of G corresponding to the subset $S - \{s_t\}$ of S where s_t is a co-minuscule node then $G/P_{[t]}$ is called a *co-minuscule flag variety*.

Remark 2.9.1. The list of all possible types of co-minuscule flag varieties are

1. $A_l/(A_k \times A_{l-k-1})$ where $0 \leq k \leq l-1$
2. $B_l/B_l - 1$
3. C_l/A_{l-1}
4. D_l/D_{l-1}
5. D_l/A_{l-1}
6. E_6/D_5
7. E_7/E_6

The types 1,4,5,6,7 are called simply-laced co-minuscule flag variety since in the root system corresponding G , all roots have the same length. Set $I = S - s_t$ then the quotient W/W_I or W^I is also said to be of *co-minuscule type*.

Remark 2.9.2. The co-minuscule flag variety of the type $A_l/(A_k \times A_{l-k-1})$, where $0 \leq k \leq l-1$, is just the Grassmannian $Gr(k, \mathbb{C}^l)$.

2.9.3 Minuscule nodes and flag varieties

We call the element $s_t \in S$, where $t \in \{1, \dots, N\}$, a *minuscule node* if and only if the coefficient of the simple co-root α_t^\vee in the highest co-root $\tilde{\alpha}^\vee$ is 1. If $P_{[t]}$ is the maximal parabolic subgroup of G corresponding to the subset $S - \{s_t\}$ of S where s_t is a minuscule node then $G/P_{[t]}$ is called a *minuscule flag variety*.

In the simply laced case (type ADE), the minuscule and co-minuscule nodes coincide since the corresponding root system and co-root system are the same. Thus all the simply laced minuscule flag varieties are exactly the simply-laced co-minuscule flag varieties (types 1,4,5,6,7 shown above). In the non-simply laced of type B_l , where $l \geq 2$, s_l is the only minuscule node and in type C_l , where $l \geq 2$, s_1 is the only minuscule node. Hence non-simply laced minuscule flag varieties are of the type B_l/A_{l-1} and C_l/C_{l-1} , where $l \geq 2$.

Chapter 3

**THE NODE-FIRING GAME AND CO-MINUSCULE
FLAG VARIETY**

3.1 Bruhat poset (W^I, \leq) for co-minuscule W^I

Let W be a Weyl group with the set S of Coxeter generators. Now Γ_S denotes the corresponding Dynkin diagram. Let $I = S - \{s_t\}$ where s_t is a co-minuscule node of S . Then W_I is the maximal parabolic subgroup of W and W^I denotes the set of minimal coset representatives of W/W_I .

3.1.1 Hasse Diagram for (W^I, \leq)

In the theory of Schubert varieties, Bruhat order plays a key role. In fact Bruhat order is actually determined by the inclusion order of Schubert varieties (see [8]). We can represent the partially ordered set (W^I, \leq) by a Hasse diagram as follows.

- Each element of W^I is represented by a vertex.
- The identity element $1 \in W^I$ is placed at the bottom (initial vertex).
- If $w, w' \in W^I$ such that w' is an immediate successors of w , that is $w \uparrow w'$, then w' is placed above the node w and connected by a straight line segment.
- All elements of the same length are at the same height from the bottom.

Example 3.1.1. Suppose Φ is of type A_3 with the corresponding Weyl group $W = \Sigma_4$, the symmetric group. Then let $S = \{s_1, s_2, s_3\}$ be the set of Coxeter generators and $I = S - \{s_2\}$.

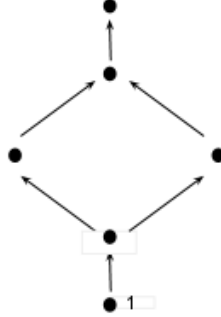

Figure 3.1: Hasse Diagram (W^I, \leq) of type $A_3/(A_1 \times A_1)$

3.1.2 Bruhat order and left weak order for co-minuscule W^I

Theorem 3.1.2. If W^I is of co-minuscule type, then the Bruhat order \leq and left weak order \leq_L coincide.

This theorem results as a consequence Theorems 6.1 and 7.1 in [28].

Using the above Theorem we know that the Hasse diagram for Bruhat poset (W^I, \leq) is the same as the diagram for (W^I, \leq_L) . Hence we can also say the following for the Hasse diagram of (W^I, \leq) .

- For $\sigma, \sigma' \in W^I$ if $\sigma \uparrow \sigma'$ then $l^I(\sigma') = l^I(\sigma) + 1$.
- All elements at the same level of the Hasse diagram are of the same length. We set the identity element $1 \in W^I$ to be at level 0.
- The level of the element in the Hasse diagram of W^I also represents its length. Set $W^{I,k}$ to be the subset of W^I containing all the minimal coset representatives of length k which is also the set of all elements at level k of the Hasse diagram.
- The elements at each level k of the Hasse diagram determine a basis of $H^{2k}(G/P_I)$. This is because $\{[X_\sigma]\}_{\sigma \in W^{I,k}}$ forms the Schubert basis for $H_{2k}(G/P_I, \mathbb{Z})$,

where $[X_\sigma]$ is the homology class of the Schubert variety X_σ . Similarly, $H^{2k}(G/P_I, \mathbb{Z})$ is free with the Kronecker dual basis $\{y_\sigma\}_{\sigma \in W^{I,k}}$.

From now on whenever we mention Hasse diagram we assume it is relative to Bruhat order but the partial order on the elements will be defined in terms of be the left weak order for convenience as the two partial orders are equivalent.

3.1.3 Longest and highest coset representative of W^I

Let w_0 be the unique longest element in W .

Theorem 3.1.3. The minimal coset representative w_0^I of w_0 is the longest element in W^I and for every element $\sigma \in W^I$, $\sigma \leq w_0^I$ in Bruhat order.

Theorem 3.1.3 is a consequence of Results 3.1.4 and 3.1.5.

Result 3.1.4. The following properties are satisfied by w_0 in W (see [16], §1.8).

1. $l(w_0 s_\alpha) < l(w_0)$ for all $\alpha \in \Delta$.
2. For any $\sigma \in W$, $l(w_0 \sigma) = l(w_0) - l(\sigma)$.
3. Given a reduced expression $\sigma = s_{i_1} \cdots s_{i_r}$ we can multiply σ successively on the right by simple reflections which increase the previous length by 1 every time until w_0 is obtained.

Result 3.1.5. Suppose v_I represents the unique longest element of W_I . Set $u^I = w_0 v_I$. Then

1. u^I is the unique longest element in W^I ,
2. every element of $\sigma \in W^I$ is such that $l(u^I \sigma^{-1}) = l(u^I) - l(\sigma)$ (see [12]).

We know that there exists unique $w_0^I \in W^I$ and $(w_0)_I \in W_I$ such that $w_0 = (w_0^I)((w_0)_I)$ (See [16], §1.10 Proposition(c)). From Result 3.1.5, we also know that $w_0 = u^I v_I^{-1}$ where $v_I^{-1} \in W_I$ and $u^I \in W^I$. Therefore we have the Theorem 3.1.3.

Remark 3.1.6. In the Hasse diagram the element at the lowest level(initial vertex) is the identity $1 \in W^I$ and the element at the highest level(terminal vertex) is $(w_0)^I$. Hence every element of W^I will lie in the Bruhat interval $[1, w_0^I]$.

3.1.4 Co-weight representation of the Bruhat poset (W^I, \leq)

Recall there is a natural partial order on the co-weight lattice \preceq defined as follows. For $\lambda_1^\vee, \lambda_2^\vee \in P(\Phi^\vee)$, $\lambda_1^\vee \preceq \lambda_2^\vee$ if and only if $\lambda_2^\vee - \lambda_1^\vee$ is a sum of positive co-roots. For any co-weight $\lambda^\vee \in \Phi^\vee$, let $W\lambda^\vee$ denote the left W -orbit of λ^\vee in the co-weight lattice.

Proposition 3.1.7. $W \cdot \omega_t^\vee$ is a co-weight poset in $P(\Phi^\vee)$ under the partial order \preceq (See [28], §1).

Proposition 3.1.8. There is a natural bijection $W^I \xrightarrow{\text{bij}} W \cdot \omega_t^\vee$ such that $\sigma \mapsto \sigma\omega_t^\vee$.

Remark 3.1.9. One can check that $\sigma_1, \sigma_2 \in W^I$, $\sigma_1\omega_t^\vee \preceq \sigma_2\omega_t^\vee$ if and only if $\sigma_2 \leq \sigma_1$ hence the above bijection is order reversing.

We set a new partial order \preceq_r for co-weights which is the reverse of the partial order \preceq . That is, $\nu^\vee \preceq_r \omega^\vee$ if and only if $\omega^\vee \preceq \nu^\vee$.

Theorem 3.1.10. The Hasse Diagram of W^I with respect to Bruhat order \leq is isomorphic to the lattice of $W \cdot \omega_t^\vee$ with respect to order \preceq_r (See Proposition 4.1 in [24]).

The construction of the lattice $(W \cdot \omega_t^\vee, \preceq_r)$ gives us the Hasse diagram with some additional information regarding co-weights in $W \cdot \omega_t^\vee$. This lattice construction will be very useful in the later chapters. Hence in the next section we will describe a technique that helps construct the lattice $(W \cdot \omega_t^\vee, \preceq_r)$

3.2 The Node Firing Game

In this section we will describe a one person game called the Node-firing game using which we can construct the lattice $(W \cdot \omega_t^\vee, \preceq_r)$. For this we will be referring to the version of Eriksson's number game studied by Donnelly in [9]. This game was originally formulated by Mozes (See [23]) and has also been studied by various others (See [10], [11]), [24], [25]). We will consider a very specialized version of the game played with the Dynkin diagrams of co-minuscule flag varieties labeled by certain co-weights.

3.2.1 Essential Definitions and Notations

Let Γ_S denote the Dynkin Diagram corresponding to the Coxeter system (W, S) and the root system (Φ, Δ) . If Γ_S consists of l nodes, then let the nodes correspond to simple roots $\Delta = \{\alpha_1, \alpha_2, \dots, \alpha_l\}$. Consider a co-minuscule flag variety G/P_I where P_I is a maximal parabolic subgroup of G corresponding to $I = S - \{s_t\}$ where s_t is a co-minuscule node of Γ_S . In this section all the following definitions are taken from [9].

Definition 3.2.1. *Position of a Dynkin diagram:* Let $M := (M_1, \dots, M_l)$ then we say M is a position of the Dynkin diagram Γ_s if M represents the diagram Γ_S labeled with integer values M_1, \dots, M_l such that M_i corresponds to node α_i .

Remark 3.2.2. Any co-weight ω^\vee represents a position of a Dynkin diagram denoted by $\omega^\vee := (\omega^\vee(i))_{\alpha_i \in \Delta}$ where $\omega^\vee(i) = (\omega^\vee, \alpha_i)$. By abuse of notation sometimes we will also refer to $\omega^\vee(i)$ by $\omega^\vee(\alpha_i)$ or $\omega^\vee(s_i)$.

Remark 3.2.3. We can clearly see that a position representation of a co-weight $(\omega^\vee(i))$ described above completely determines the co-weight.

Example 3.2.4. Here are some examples of a co-weights as positions.

1. In type A_2

$$\omega_1^\vee : \begin{array}{c} \bullet \text{---} \bullet \\ 1 \quad 0 \end{array}$$

2. In type A_3

$$\omega_1^\vee - 2\omega_3^\vee : \begin{array}{c} \bullet \text{---} \bullet \text{---} \bullet \\ 1 \quad 0 \quad -2 \end{array}$$

Definition 3.2.5. *A fundamental position ω_i^\vee of Γ_S :* A fundamental position represents Γ_S labeled with number 1 for node α_i and 0 for all other nodes. In other words, the a fundamental position represents the fundamental co-weight ω_i^\vee .

Definition 3.2.6. *Firing a node α_i of M :* Firing a node α_i of M gives us a new position $N = (N_1, \dots, N_l)$ of Γ_S provided node M_i is a positive integer. The new position is determined in the following way.

1. $N_i := -(M_i)$.

2. If α_j is a node adjacent to α_i then

$$N_j := \begin{cases} M_j + M_i & \text{if } |\alpha_j| \leq |\alpha_i| \\ M_j + 2M_i & \text{if } |\alpha_j| = 2|\alpha_i| \end{cases}$$

3. If α_j is a node not adjacent to α_i then $N_j := M_j$.

Denote the new position N by $s_{\alpha_i}M$.

Remark 3.2.7. When node α_i is fired on a co-weight ω^\vee , the new position formed is just the co-weight $s_{\alpha_i}\omega^\vee$.

Example 3.2.8. Consider the co-weight position ω_2^\vee in C_3

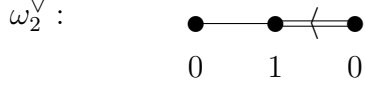

Then firing node α_2 on ω_2^\vee will be as follows.

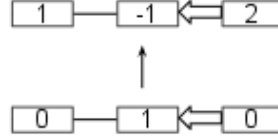

Definition 3.2.9. *A firing sequence of a position M :* A firing sequence $(\alpha_{i_1}, \alpha_{i_2}, \dots, \alpha_{i_l})$ of a position M ($\alpha_{i_k} \in \Delta$) represents a sequence of l steps played on the position M as follows. First step is to fire the node α_{i_1} of M to determine a new position $s_{\alpha_{i_1}} M$. Next step is to fire the node α_{i_2} of $s_{\alpha_{i_1}} M$ to determine the new position $s_{\alpha_{i_2}} s_{\alpha_{i_1}} M$. Continue in this manner for l steps until you determine the position $s_{\alpha_{i_l}} \dots s_{\alpha_{i_2}} s_{\alpha_{i_1}} M$.

Remark 3.2.10. Any firing sequence it is assumed to be *legal*. A legal firing sequence ensures that node-firing is possible at each step, that is, $s_{\alpha_{i_{k-1}}} \dots s_{\alpha_{i_2}} s_{\alpha_{i_1}} M$ has a positive label for node α_{i_k} .

Definition 3.2.11. *A game sequence of a position M :* A game sequence is a maximal firing sequence of position M . It could be an empty, finite or an infinite sequence. A finite game sequence $(\alpha_{i_1}, \alpha_{i_2}, \dots, \alpha_{i_l})$ of a position M represents a firing sequence such that there are no positively labeled node for $s_{\alpha_{i_l}} \dots s_{\alpha_{i_2}} s_{\alpha_{i_1}} M$. This marks the end of the game.

Definition 3.2.12. *Strongly convergent game:* Given any initial position, if every game sequence either diverges or converges to the same terminal position in the same number of steps then we say the game is strongly convergent.

3.2.2 Convergence in a node-firing game and Bruhat poset (W^I, \leq)

Using proposition 3.2, corollary 3.3 and corollary 3.4 from [9] we can state the following theorem.

Theorem 3.2.13. If ω_t^\vee is a fundamental co-weight then $(\alpha_{i_1}, \alpha_{i_2}, \dots, \alpha_{i_l})$ is a game sequence for ω_t^\vee if and only if $s_{\alpha_{i_l}} \cdots s_{\alpha_{i_2}} s_{\alpha_{i_1}} = (w_0)^J$.

Remark 3.2.14. In the above Theorem we don't require s_t to be a co-minuscule node. By Remark ?? and Theorem 3.2.13 we have the following result.

Corollary 3.2.15. We can use the node-firing game with ω_t^\vee as the initial position to construct a poset diagram of $(W \cdot \omega_t^\vee, \preceq_r)$ in the co-weight lattice as follows.

1. Sketch ω_t^\vee as the initial position (as shown in Example 3.2.4)
2. For each game sequence $(\alpha_{i_1}, \alpha_{i_2}, \dots, \alpha_{i_l})$, sketch the position $s_{\alpha_{i_j}} \cdots s_{\alpha_{i_2}} s_{\alpha_{i_1}} \omega_t^\vee$ above $s_{\alpha_{i_{j-1}}} \cdots s_{\alpha_{i_2}} s_{\alpha_{i_1}} \omega_t^\vee$ with an upward arrow connecting them for $1 \leq j \leq l$.
3. Combine the diagram of all game sequences into one by merging all the identical positions of each of the game sequence. Hence we will start with the same initial position ω_t^\vee , ending with the terminal position $(w_0)^J \omega_t^\vee$.

The poset diagram of $(W\omega_t^\vee, \preceq_r)$ hence drawn using the node-firing game gives us the Hasse diagram of (W^I, \leq) (see Proposition 3.1.10) along with the description of each the co-weights of $W\omega_t^\vee$ as functions on the simple roots. This poset diagram construction will be very relevant for the rest of the Thesis.

Example 3.2.16. Consider the fundamental co-weight ω_2^\vee in type A_3 as an initial position.

$$\omega_2^\vee: \quad \bullet \text{---} \bullet \text{---} \bullet$$

$$\quad \quad \quad 0 \quad 1 \quad 0$$

Then the node-firing game with the initial position ω_2^\vee is given in Figure 3.2. The resulting diagram can be seen is clearly isomorphic as a poset to the Hasse diagram of (W^I, \leq) when W^I is of type $A_3/(A_1 \times A_1)$.

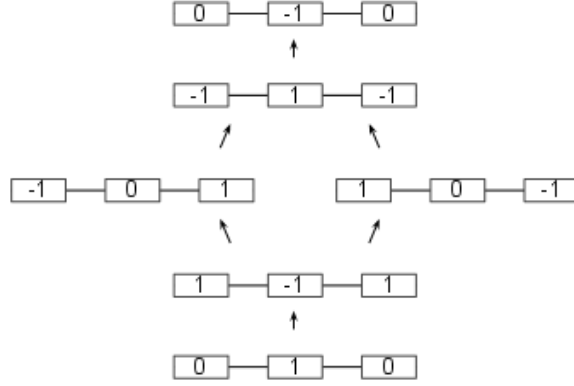

Figure 3.2: Node-firing game for ω_2^\vee in A_3

Result 3.2.17. Here are some important relations that can be deciphered from the node-firing game on ω_t^\vee . For any co-weight of the form $\omega^\vee = w\omega_t^\vee$ for $w \in W^I$, where $I = S - \{s_t\}$,

1. $\omega^\vee(i) = 0 \Leftrightarrow s_i\omega^\vee = \omega^\vee \Leftrightarrow s_iw = w$.
2. $\omega^\vee(i) = -1 \Leftrightarrow s_i\omega^\vee \prec \omega^\vee \Leftrightarrow s_iw \uparrow w$.
3. $\omega^\vee(i) = 1 \Leftrightarrow \omega^\vee \prec s_i\omega^\vee \Leftrightarrow w \uparrow s_iw$.

We also have the following nice theorem when we consider the node-firing game on a co-minuscule co-weight.

Theorem 3.2.18. Suppose $s_t \in S$ is a co-minuscule node. Let ω_t^\vee be the fundamental co-weight corresponding to root α_t . Then co-weight $\omega^\vee = w\omega_t^\vee$ considered as position of the node-firing game labels every simple root only with integers 0, 1 or -1.

Proof. For any $\alpha_i \in \Delta$, we know that the label of ω^\vee at α is $\omega^\vee(i)$. Now

$$\omega^\vee(i) = (\omega^\vee, \alpha_i) = (w\omega_t^\vee, \alpha_i) = (\omega_t^\vee, w^{-1}\alpha_i).$$

Since s_t is co-minuscule, the coefficient of α_t in the highest root $\tilde{\alpha}$ is equal to 1. That is, $(\omega_t^\vee, \tilde{\alpha}) = 1$. For any $\beta \in \Theta$, by definition of the highest root, $\tilde{\alpha} - \beta$ is a sum of

positive roots. Thus the coefficient of α_t in β can be at most 1. Thus $(\omega_t^\vee, \beta) \leq 1$. If $(\omega_t^\vee, \beta) < -1$ then β is a negative root and $(\omega_t^\vee, -\beta) > 1$ which contradicts our assumption that $\tilde{\alpha}$ is the highest root. Thus $(\omega_t^\vee, \beta) \geq -1$. Therefore, for any $\beta \in \Theta$, $(\omega_t^\vee, \beta) = 0, 1$ or -1 . In particular choosing $\beta = w^{-1}\alpha_i$ we get

$$\omega^\vee(i) = 0, 1 \text{ or } -1 \text{ for all } i$$

□

3.2.3 Node-firing game on weights

Bruhat poset (W^I, \leq) and poset $(W \cdot \omega_t, \preceq_r)$

Let ω_t be the fundamental weight corresponding to the co-minuscule node s_t in Γ_S . Set \preceq_r to be the order on weights given by $\nu \prec \omega$ if and only if $\nu - \omega$ is a sum of positive roots (intuitively we see that this is the reverse of the natural order on weights). Since a fundamental weight is just the fundamental co-weight of the corresponding dual root system and since the Weyl group is the same for a root system and its dual, we can restate Theorem 3.1.10 as

Theorem 3.2.19. The Hasse Diagram of W^I with respect to Bruhat order \leq is isomorphic to the lattice of $W \cdot \omega_t$ with respect to order \preceq_r .

Remark 3.2.20. The posets of weight lattice $(W \cdot \omega_t, \preceq_r)$ and the poset of the co-weight lattice $(W \cdot \omega_t^\vee, \preceq_r)$ are isomorphic.

Node-firing game

Since weight ω can be thought of as a co-weight of the corresponding dual root system the discussion on node-firing game given in (3.2.1) and (3.2.2) applies here.

Remark 3.2.21. We can consider a weight ω to represent a position of the Dynkin diagram corresponding to the dual root system Φ^\vee denoted by $\omega := (\omega(i))_{\alpha_i^\vee \in \Delta^\vee}$ where $\omega(i) = (\omega^\vee, \alpha^\vee)$.

Result 3.2.22. By theorem 3.2.13, the node-firing game with ω_t as the initial position we can construct a poset diagram of $(W \cdot \omega_t^\vee, \preceq_r)$ in the weight lattice using the steps given in corollary 3.2.15.

Remark 3.2.23. In the simply-laced case since $\Phi = \Phi^\vee$ the node-firing game on ω_t^\vee is identical to the game played on ω_t .

Remark 3.2.24. In the non-simply laced case, even though the lattices $(W \cdot \omega_t, \preceq_r)$ and $(W \cdot \omega_t^\vee, \preceq_r)$ are isomorphic, since s_t is no longer a co-minuscule node of Dynkin diagram of the dual root system, in the node-firing game on ω_t the label values the positions can be 0, 1, -1, 2, -2 while in the node-firing game on ω_t^\vee the label values the positions can only be 0, 1, -1(See Theorem 3.2.18)

Chapter 4

THOM VARIETY**4.1 Parabolic orbits in flag varieties***4.1.1 Basic notations*

Let G be a reductive complex algebraic group. Fix a Borel subgroup B in G containing a maximal torus H and connected unipotent subgroup of U . The unipotent radical of B , $\mathcal{R}_u(B) = U$. Now $W = N_G(H)/H$ is the Weyl group of G with a set of Coxeter generators S , such that (W, S) is a Coxeter system. Let Φ be the root system corresponding to \mathfrak{g} . For any subset I of S , let W_I denote the parabolic subgroup of W generated by I , and let $P_I = BW_I B$ denote the parabolic subgroup of G corresponding to I . Then (W_I, I) is itself a Coxeter system. Suppose J is another subset of S , then let W^{IJ} be the set of minimal length representatives of the set of double cosets $W_I \backslash W/W_J$.

4.1.2 Parabolic orbits and Bruhat decomposition

If $I, J \subset S$ then G has the following double-coset decomposition

$$G = \coprod_{w \in W_I \backslash W/W_J} P_I w P_J.$$

We can also index the above decomposition in terms of the minimal length representatives W^{IJ} . If we consider the left P_I -action on the flag variety G/P_J , then similarly G/P_J also has the double-coset decomposition

$$G/P_J = \coprod_{w \in W^{IJ}} P_I w P_J/P_J. \quad (4.1)$$

We call each $P_I w P_J / P_J$ a *parabolic orbit* of G/P_J and we denote the parabolic orbit by \mathcal{O}_w . In fact, if $I = \phi$ then $P_I = B$ and hence the parabolic orbits are the Schubert cells $e_w = BwP_J/P_J$ and the decomposition given in (4.1) is just the Bruhat decomposition (§8.5, [26]). Now if we let $K_w = \{s \in I \mid w^{-1}sw \in J\}$ then we can see that

$$\mathcal{O}_w = \coprod_{v \in W_I w W_J / W_J} e_v = \coprod_{\nu \in (W_I)^{K_w}} e_{\nu w} \quad (4.2)$$

4.1.3 The line bundle $\mathcal{O}_s \downarrow M_s$

Let I be a maximal subset of S , say $I = S - \{s\}$. Let L_I be the Levi subgroup of P_I . Then L_I is a reductive complex algebraic group such that W_I is its Weyl group and I is the corresponding set Coxeter generators. Consider the left P_I action on the flag variety G/P_I . Then \mathcal{O}_s is the lowest non-trivial P_I -orbit in G/P_I where clearly s is the minimal length representative of $W_I s W_I$ hence an element of W^{IJ} . The lowest P_I -orbit is $P_I \cdot 1P_I/P_I = P_I/P_I$, which we also call the base-point of G/P_I . Now the set K_s is just I minus the nodes adjacent to s in the Dynkin diagram Γ . Let Q_{K_s} denote the parabolic subgroup of L_I corresponding to the subset K_s of I . Let M_s denote the flag variety L_I/Q_{K_s} . It is well-known that \mathcal{O}_s is isomorphic as a variety to a certain line bundle ξ_s over the flag variety M_s . Since ξ_s plays a fundamental role throughout this work, we describe it and the isomorphism in detail.

First we need to recall some relevant facts on Bruhat decomposition. Let B^- be the opposite Borel subgroup of B and $U^- = \mathcal{R}_u(B^-)$. Then for any $w \in I$ we define the following.

$$U'_w = \{u \in U : w^{-1}uw \in U^-\}$$

$$\Phi'_w = \{\alpha \in \Phi^+ : w^{-1}\alpha \in \Phi^-\}$$

Then we have that U'_w corresponds to the subset Φ'_w and from remark (3) of 14.12 in [3]

$$BwB = U'_w w B. \quad (4.3)$$

We will also need following lemma which is a well-known generalization of Theorem 15 from Lectures on Chevalley Groups ([27]), which is proved the same way. (See Theorem 5.1.3 (i) in [19] and Result 2.9 in [22])

Lemma 4.1.1. Fix a subset I of S and let $w \in W^I$ such that $w = w_1 \cdots w_k$ is a I -reduced product. Let $A_i \subset Bw_iB$ be any subsets such that for all i , the natural map $p_i : A_i \rightarrow Bw_iB$ is bijective[surjective]. Then the natural map $p : A_1 \times \cdots \times A_k \rightarrow G/P_I$, namely

$$p(a_1, \cdots, a_k) = a_1 \cdots a_k P_I / P_I$$

is a bijection [surjection] onto $B_I w Q_K / Q_K$.

Now consider the map $L_I \times e_s \rightarrow \mathcal{O}_s$ given by the action. Let Q be the stabilizer of e_s in L_I then $B \cap L_I \subseteq Q$, hence Q is parabolic subgroup of L_I . Then there is a subgroup K of I such that $Q_K = Q$. The definition of Q implies $K = \{t \in I \mid t \cdot BsP_I/P_I = BsP_I/P_I\}$. That is, $K = \{t \in I \mid ts = st\} = K_s$. Hence $Q = Q_{K_s}$. This gives us the following injective map.

$$\phi : L_I \times_{Q_{K_s}} e_s \rightarrow \mathcal{O}_s$$

We would like to show that ϕ is an isomorphism of varieties but before that we need the following lemmas.

Proposition 4.1.2. The map ϕ is an isomorphism of varieties.

Proof. Let $B_I = B \cap L_I$ be the Borel subgroup of L_I with a maximal torus T and unipotent radical U_I . Then we have a double coset decomposition of L_I given by

$$L_I = \coprod_{v \in (W_I)^{K_s}} B_I v Q_{K_s}.$$

For any $v \in W_I$ define

$$U'_{I,v} = \{u \in U_I \mid v^{-1} u v \in U_I^-\}$$

Then using (4.3) we can say that $B_I v Q_{K_s} = U'_{I,v} v Q_{K_s}$ for all $v \in (W_I)^{K_s}$. Hence the domain of ϕ has a cell decomposition as follows.

$$L_I \times_{Q_{K_s}} e_s = \coprod_{v \in W_I^{K_s}} U'_{I,v} v \times e_s.$$

Define the set $\Phi'_{I,v} = \{\alpha \in \Phi_I^+ : v^{-1}\alpha \in \Phi_I^-\}$ corresponding to $U'_{I,v}$. Clearly, $\Phi'_{I,v} \subseteq \Phi'_v$. Since $v \in W_I$ and W_I preserves the set of I -radical roots $\Phi^+ - \Phi_I^+$. Thus if $\alpha \in \Phi'_v$ then $\alpha \in \Phi_I^+$. Therefore $\Phi'_{I,v} = \Phi'_v$ which implies the corresponding subgroups are equal. That is, if $v \in W_I$ then $U'_{I,v} = U'_v$. Hence we have

$$L_I \times_{Q_{K_s}} e_s = \coprod_{v \in W_I^{K_s}} U'_v v \times e_s.$$

Also note that

$$\mathcal{O}_s = \coprod_{v \in W_I^{K_s}} e_{vs}.$$

Now $e_s = U'_s P_I / P_I$ and $e_{vs} = U'_{vs} v s P_I / P_I = B v s P_I / P_I$. For $v \in W_I^{K_s}$, vs is such that $v \in W_I$ and $s \notin W_I$ so we can choose $A_1 = U'_v v$ and $A_2 = U'_s s$. Thus Lemma 4.1.1) shows that ϕ maps each cell in the domain bijectively to its counterpart in the codomain. This proves that ϕ is bijective. Further ϕ is also an isomorphism of varieties by Zariski's main theorem ([13]), proving our claim. \square

The Schubert cell e_s as a one dimensional space. We next consider the action of Q_{K_s} on e_s and determine the kernel of this action; i.e. the subgroup of Q_{K_s} that fixes e_s point-wise. We will use the following general fact concerning commutation of root subgroups.

Lemma 4.1.3. Suppose α, β are roots and $x \in U_\alpha, y \in U_\beta$. Then

- (a) If $\alpha + \beta$ is not a root, $xy = yx$.
- (b) In general $xy = yx z_1 \dots z_r$, where $z_i \in U_{\gamma_i}$ for some $\gamma_i = m\alpha + n\beta$ with $m, n > 0$.

For a proof see [15] § 33.2, where more refined statements can be found. For example, if α, β generate a root system of type A_2 , one has $xy = yxz$ with $z \in U_{\alpha+\beta}$. In fact Humphreys even gives explicit formulas for z in terms of x, y , but these are not important for us.

Let Q' denote the subgroup of Q_{K_s} generated by the root subgroups contained in Q_{K_s} . Thus there is a group extension $Q' \rightarrow Q_{K_s} \rightarrow H$ where H is a complex torus.

Lemma 4.1.4. Q' fixes e_s point-wise.

Proof. We show that the generating root subgroups of Q fix e_s point-wise. Consider a root subgroup U_{α_t} corresponding to a simple root α_t , $t \in I$. Since $t \neq s$, all such U_{α_t} fix sP_I/P_I . Now $e_s = U'_s sP_I/P_I$. But $U'_s = U_{\alpha_s}$ so if $y \in U_s$ and $x \in U_{\alpha_t}$, then by the commutation lemma b and since xz is a product of elements from U_{α_t} 's with $t \neq s$

$$xysP_I/P_I = yxzsP_I/P_I = ysP_I/P_I.$$

If $t \in K_s$, then also the negative root subgroup $U_{\alpha_t}^-$ acts trivially, by the commutation lemma part (a). Hence proved. \square

Thus Q_{K_s} acts on e_s via a certain homomorphism $\omega : Q_{K_s} \rightarrow \mathbb{C}^\times$, and it is clear that as a weight on the maximal torus of L_I , ω is just the restriction of the root α_s . We summarize our conclusions in the following proposition:

Proposition 4.1.5. The total space of the line bundle $\xi_s \downarrow L_I/Q_{K_s}$ associated to the weight α_s (restriction of root α_s on maximal torus of L_I defined on Q_{K_s}) $E(\xi_s) = L_I \times e_s$. Hence there is an isomorphism of varieties $E(\xi_s) \xrightarrow{\cong} \mathcal{O}_s$.

4.2 Thom Variety

4.2.1 Thom space of line bundle ξ_s

Let ξ_s be the line bundle described in the previous section with the projection map $\pi_s : \mathcal{O}_s \downarrow M_s$. Let X denote the Zariski-closure of \mathcal{O}_s . From 4.2 we know that

$$\mathcal{O}_s = \coprod_{\nu \in (W_I)^{K_s}} e_{\nu s}. \quad (4.4)$$

Hence X is the Schubert variety X_σ , where $\sigma = \nu_m s$ where ν_m is the maximal element in $(W_I)^{K_s}$. Then we can see that

$$X = \overline{\mathcal{O}_s} = \coprod_{w' \leq s} \mathcal{O}_{w'}$$

Since there are only two w' such that $w' \leq s$, namely identity element 1 and s itself, $X = \mathcal{O}_s \cup *$, where $*$ = P_I/P_I is the basepoint. Thus we can consider X to be the one point compactification of the total space of line bundle ξ_s . Hence X can be identified with $T(\xi_s)$, the Thom space of the line bundle ξ_s . We call X a *Thom variety*.

4.2.2 Understanding the Cohomology ring $H^*(X)$ of a Thom variety X .

Let the map $\Phi_T : H^*(M_s) \rightarrow H^{*+2n}(T(\xi_s))$ be the Thom isomorphism (see §19 [21]). Then we note that there are two natural bases for $H^*(X)$, one the natural Schubert basis, and the other is the basis inherited from the Schubert basis for $H^*(M_s)$ via the Thom isomorphism. We would like to show that these two bases coincide.

Since $M_s = L_I/Q_{K_s}$ is a flag variety where L_I is the Levi factor of P_I and Q_{K_s} is its parabolic subgroup corresponding to the subset K_s of I that contains all nodes not adjacent to s . Thus $H_*(M_s) = H_*(L_I/Q_{K_s})$ has its natural Schubert basis $\{[Z_w]\}_{w \in (W_I)^{K_s}}$. Hence $H^*(M_s)$ has the corresponding Schubert basis $\{[Z_w]^*\}_{w \in (W_I)^{K_s}}$. Similarly $H^*(T(\xi_s))$ has the natural Schubert basis $\{[T_w]^*\}_{w \in W_I^K}$ where $T_w = T(\xi_s|_{Z_w})$

and $H^*(X)$ has the Schubert basis $\{[X_{ws}]^*\}_{w \in W_I^K}$ (in $H_0(X)$, the basis will also contain the base point class.). Thus we would like to prove the following.

Proposition 4.2.1. Given the Thom isomorphism $\Phi_T : H^*(M_s) \rightarrow H^{*+2n}(T(\xi_s))$ and canonical homeomorphism $f : T(\xi_s) \rightarrow X$ we have

$$f^*([X_{ws}]^*) = \Phi_T([Z_w]^*).$$

For the proof of this proposition we will use the following two lemmas.

Lemma 4.2.2. If Y is an irreducible n -dimensional projective variety then Y has a fundamental class $[Y]^* \in H^{2n}(Y)$.

Lemma 4.2.3. For all $w \in W_I^K$, $f(T_w) = X_{ws}$.

This is true by Lemma 4.1.1.

Proof of Proposition 4.2.1.

Consider the line bundle $\xi_s|_{Z_w}$. Then by Lemma 4.2.2, Z_w and $T_w = T(\xi_s|_{Z_w})$ have the fundamental classes $[Z_w]^* \in H^{2n}(Z_w)$ and $[T_w]^* \in H^{2n+2}(T_w)$ respectively. Since both $H^{2n}(Z_w)$ and $H^{2n+2}(T_w)$ are isomorphic to \mathbb{Z} so the Thom isomorphism $\Phi_T : H^{2n}(Z_w) \rightarrow H^{2n+2}(T_w)$ maps one \mathbb{Z} to another. This implies $\Phi_T([Z_w]^*) = \pm[T_w]^*$. Since everything is complex, the orientations automatically match up, hence the Thom isomorphism $\Phi_T : H^{2n}(Z_w) \rightarrow H^{2n+2}(T_w)$ takes $[Z_w]^*$ to $[T_w]^*$. Now by naturality of Thom isomorphism we have the that $\Phi_T : H^*(M_s) \rightarrow H^{*+2n}(T(\xi_s))$ is such that

$$\Phi_T([Z_w]^*) = [T_w]^* \text{ for all } w \in W_I^K. \quad (4.5)$$

Further from Lemma 4.2.3 we have the following.

$$f^*([X_{ws}]^*) = [T_w]^* \text{ for all } w \in W_I^K \quad (4.6)$$

From (4.5) and (4.6) we have the required result. \square

4.2.3 Singularities of Thom variety

Since a Thom variety is the one point compactification of the total space of the line bundle ξ_s by definition, we can say that the possible point of singularity of $T(\xi_s)$ is the point at infinity. But the point at infinity need not be singular in all cases.

Example 4.2.4. The co-minuscule flag variety of type A_n/A_{n-1} is the flag variety $G/P_I \cong \mathbb{C}\mathbb{P}^n$ where the Weyl group $W = \Sigma_{n+1}$ is the symmetric group and $S = \{s_1, \dots, s_n\}$ is the corresponding Coxeter generators. We can choose $I = S - \{s_1\}$. Then the Thom variety $T(\xi_{s_1}) \cong \mathbb{C}\mathbb{P}^n$ and hence the point at infinity is not a singular point.

Chapter 5

LOCAL COHOMOLOGY OF SCHUBERT VARIETIES AT A GENERIC SINGULARITIES AND THOM VARIETIES

The fundamental thought we explore in this thesis is what can one say about the local topology of Schubert variety X_w at a singular point \bar{v} ? We do this by specifically computing $H^*(X_w, X_w - \bar{v})$ where \bar{v} is a generic singularity under certain hypothesis. In this Chapter, we better understand the problem we want to focus on and also simplify our process using Thom varieties.

5.1 Local cohomology

Let Y be any space and let $y_0 \in Y$. The *local cohomology at y_0 of Y* is defined to be the relative cohomology of the pair $(Y, Y - y_0)$, that is

$$H_{y_0}^*(Y) = H^*(Y, Y - y_0).$$

Now suppose U is any neighborhood of y_0 . Since $Y - U \subseteq Y - y_0 \subseteq Y$ by applying the excision theorem we have that $H^*(U, U - y_0) \cong H^*(Y, Y - y_0)$. Hence we can see that $H_{y_0}^*(Y) \cong H_{y_0}^*(U)$.

Now suppose Y is a variety of dimension n and $y_0 \in Y$, then we then have the following.

Remark 5.1.1. If y_0 is a smooth point of Y then by excision (see [14])

$$H_{y_0}^i(Y; \mathbb{Z}) \cong H_0^i(\mathbb{C}^n; \mathbb{Z}) = \begin{cases} \mathbb{Z} & \text{for } i = 2n \\ 0 & \text{otherwise.} \end{cases}$$

Remark 5.1.2. Y is said to be *rationally smooth at point y_0* if the isomorphism above holds with rational coefficients. That is,

$$H_{y_0}^*(Y; \mathbb{Q}) \cong H_0^*(\mathbb{C}^n; \mathbb{Q}).$$

From now on when we talk about cohomology we will be referring to only to integral cohomology unless otherwise specified.

5.2 Local cohomology of a Schubert variety at a generic singularity

Let G_Θ be a reductive complex algebraic group and \mathfrak{g}_Θ be its Lie algebra with the root system Θ . Let W_Θ be the corresponding Weyl group with Coxeter generators S_Θ . For some subset $J \subseteq S_\Theta$ let P_J be a parabolic subgroup of G_Θ . Let X_w be a Schubert variety in the flag variety G_Θ/P_J for some $w \in W_\Theta^J$.

5.2.1 Generic Singularities

The singular locus of X_w is a finite union of Schubert varieties. Define subset \mathcal{A}_w of W_Θ^J such that $v \in \mathcal{A}_w$ if and only if X_v is a maximal Schubert variety in $Sing(X_w)$ by (Bruhat)order of inclusion. Hence we can write

$$Sing(X_w) = \bigcup_{v \in \mathcal{A}_w} X_v.$$

Definition 5.2.1. All the points $\bar{v} = vP_J/P_J$ in X_w such that $v \in \mathcal{A}_w$ are called *generic singularities* of X_w .

5.2.2 Local cohomology of X_w at a generic singularity and Thom variety

Pick any generic singularity \bar{v} of X_w . Let $m = l(v)$. We denote by $R_{v,w}$ the Richardson variety $X_w \cap X_v^-$. Then we have the following lemma.

Lemma 5.2.2. $H_{\bar{v}}^*(X_w) \cong H_{\bar{v}}^{*-2m}(R_{v,w})$

Proof. Since (X_w, \bar{v}) is ‘smoothly equivalent’ to $(R_{v,w}, \bar{v})$ in the strong sense, \bar{v} has a Zariski-open neighborhood U in X_w and V in $R_{v,w}$ such that $U \cong V \times \mathbb{A}^m$ as varieties and $\bar{v} \in U$ corresponds to the $(\bar{v}, 0) \in V \times \mathbb{A}^m$. Thus $H_{\bar{v}}^*(U) \cong H_{\bar{v}}^*(V) \otimes H_0^*(\mathbb{A}^m)$ by Künneth theorem. Since $H_0^*(\mathbb{A}^m) \cong \tilde{H}^*(S^{2m})$, we have that $H_{\bar{v}}^*(U) \cong H_{\bar{v}}^{*-2m}(R_{v,w})$. \square

Using this lemma we get the following theorem which relates the local cohomology at a generic singularity of a Schubert variety to a Thom variety introduced in the previous chapter.

Theorem 5.2.3. Suppose there is a line bundle ξ_s over a flag variety M_s , as described in (4.1.3) in Chapter 4, such that $R_{v,w}$ can be identified with the Thom variety $T(\xi_s)$ then

$$H_{\bar{v}}^*(X_w) \cong H^{*-2m-1}(\mathcal{O}_s - M_s).$$

Proof. If we can identify $R_{v,w}$ with a Thom variety $T(\xi_s)$ then

$$H_{\bar{v}}^*(R_{v,w}) \cong H_{\infty}^*(T(\xi_s)). \quad (5.1)$$

Since $M_s \subseteq T(\xi_s) - \infty \subseteq T(\xi_s)$ by excision we have that

$$H_{\infty}^*(T(\xi_s)) \cong H_{\infty}^*(T(\xi_s) - M_s). \quad (5.2)$$

Now $T(\xi_s)$ is identified with the one point compactification of \mathcal{O}_s (see 4.1.3) thus we can identify $T(\xi_s) - M_s - \infty$ with $\mathcal{O}_s - M_s$. Further since $T(\xi_s) - M_s$ is contractible, by taking the long exact sequence of the pair $(T(\xi_s) - M_s, \mathcal{O}_s - M_s)$ we get

$$H_{\infty}^*(T(\xi_s) - M_s) \cong H^{*-1}(\mathcal{O}_s - M_s) \quad (5.3)$$

Hence using 5.1, 5.2, 5.3 and Lemma 5.2.2 we have the required result. \square

5.2.3 $H^*(\mathcal{O}_s - M_s)$ and the Gysin sequence

For the line bundle ξ_s we know we can denote the base space M_s be the flag variety of the form L_I/Q_{K_s} where L_I is a complex, reductive algebraic group. Fix a Borel subgroup B_I and maximal torus T_I of L_I . Let (W_I, I) be the Coxeter system where W_I is Weyl group corresponding to L_I and the I is the set of Coxeter generators of W_I . Hence Q_{K_s} is a parabolic subgroup of L_I corresponding to subset $K_s \subseteq I$. Further let Φ_I be the root system corresponding the Lie algebra \mathfrak{g}_I of L_I , with set of simple roots Δ_I .

Theorem 5.2.4. Let the map $H^*(M_s) \xrightarrow{c_1(\xi_s)} H^{*+2}(M_s)$ denote the cup product with $c_1(\xi_s)$ where $c_1(\xi_s) \in H^2(M_s)$ is the first Chern class of ξ_s . Then we have the following relations.

$$H^n(\mathcal{O}_s - M_s) \simeq \begin{cases} \text{Coker}(H^{n-2}(M_s) \xrightarrow{c_1(\xi_s)} H^n(M_s)) & \text{if } n \text{ is even.} \\ \text{Ker}(H^{n-1}(M_s) \xrightarrow{c_1(\xi_s)} H^{n+1}(M_s)) & \text{if } n \text{ is odd.} \end{cases}$$

Proof. Consider the Gysin sequence for the line bundle ξ_s minus the zero section (pg. 143, [21]), given as follows.

$$\cdots \rightarrow H^{*-2}(M_s) \xrightarrow{c_1(\xi_s)} H^*(M_s) \rightarrow H^*(\mathcal{O}_s - M_s) \rightarrow H^{*-1}(M_s) \xrightarrow{c_1(\xi_s)} H^{*+1}(M_s) \rightarrow \cdots$$

From this we derive the following short exact sequence.

$$0 \rightarrow A \rightarrow H^*(\mathcal{O}_s - M_s) \rightarrow B \rightarrow 0$$

where $A = \text{Coker}(H^{*-2}(M_s) \xrightarrow{c_1(\xi_s)} H^*(M_s))$ and $B = \text{Ker}(H^{*-1}(M_s) \xrightarrow{c_1(\xi_s)} H^{*+1}(M_s))$.

By looking at the cases when n is odd and n is even separately for $H^n(\mathcal{O}_s - M_s)$ in the above short exact sequence and using the fact the cohomology of M_s is concentrated in even degrees, we get the required relations in terms of the cup product with $c_1(\xi_s)$. \square

In the next chapter we would now like to determine a ‘nice’ hypothesis under which we identify the Richardson variety $R_{v,w}$ with a Thom variety $T(\xi_s)$.

Chapter 6

**RICHARDSON VARIETY AS THOM VARIETY IN
CO-MINUSCULE FLAG VARIETIES**

To further analyze the local cohomology at a generic singularity of Schubert variety, based on Theorem 5.2.3, we would like to now consider the following question: “Under what hypothesis, given a generic singular point \bar{v} of a Schubert variety X_w , can we identify the Richardson variety $R_{v,w}$ with a Thom variety?” We derive an answer to this question reformulating results from [5] which are based on the hypothesis that we consider the Schubert variety in a co-minuscule flag variety.

6.1 Minimal degeneration and Richardson variety as Thom variety

6.1.1 Minimal degeneration

Let G_Θ be a reductive complex algebraic group and \mathfrak{g}_Θ be its Lie algebra with the root system Θ . Let W_Θ be the corresponding Weyl group with Coxeter generators S_Θ . For some subset $J \subseteq S_\Theta$ let P_J be a parabolic subgroup of G_Θ . Let X_w be a Schubert variety in the flag variety G_Θ/P_J for some $w \in W_\Theta^J$. For any $u \in W_\Theta^J$ let \bar{u} denote the point uP_J/P_J in G_Θ/P_J . Now let J_w be a subset of S_Θ defined by $J_w = \{s \in S_\Theta : sw \leq w\}$, that is $P_{J_w} = \text{Stab}X_w$.

Definition 6.1.1. Let $w \in W_\Theta^J$. If $v \in W_\Theta^J$ is a maximal element relative to Bruhat order in the set $[e, w(W_\Theta)_J] - (W_\Theta)_{J_w}w$ then we call v a *minimal degeneration* of w .

The parabolic orbit $P_{J_w}wP_J/P_J$ is smooth since \bar{w} is a smooth point of X_w . Thus $P_{J_w}wP_J/P_J \subseteq X_w^{\text{smooth}}$, and we have the following remarks.

Remark 6.1.2. If v is a minimal degeneration of $w \in W_\Theta^J$ then \bar{v} is a maximal possible element in the Bruhat order that could be a singular point of X_w .

Remark 6.1.3. If v is a minimal degeneration of w such that \bar{v} is a singular point of X_w then \bar{v} is a generic singular point.

6.1.2 Richardson variety as Thom variety

Using the notations given in Section 6.1.1, let $R_{v,w}$ be a Richardson variety in G_Θ/P_J where $v, w \in W_\Theta^J$ such that v is a minimal degeneration of w . By definition of minimal degeneration there is a reflection s_γ such that $v \leq s_\gamma v$ and $s_\gamma v \in (W_\Theta)_{J_w} \cdot w(W_\Theta)_J$.

Proposition 6.1.4. Suppose there is a subset I' of J_w such that the following three conditions are satisfied.

1. The left action of $(W_\Theta)_{I'}$ on W_Θ^J fixes v . That is, $sv(W_\Theta)_J = v(W_\Theta)_J$ for all $s \in I'$.
2. The left $(W_\Theta)_{I'}$ orbit of $s_\gamma v$ in W_Θ^J contains w .
3. If $S' = I' \cup \{s_\gamma\}$ then the set of roots $\{\alpha \in \Theta : s_\alpha \in S'\}$ forms a simple system of roots that generates a sub-root system Φ of Θ .

Let $G' = G_{S'}$ be the Levi subgroup of parabolic subgroup $P_{S'}$ of G_Θ and $Q_{I'}$ is a maximal parabolic subgroup of G' corresponding to the subset I' of S' . Then

(a) Richardson variety $R_{v,w}$ in G_Θ/P_J is also a Schubert variety in the flag variety $G'/Q_{I'}$.

(b) $R_{v,w}$ is equal to the Thom variety $T(\xi_{s_\gamma})$ where ξ_{s_γ} is the line bundle $\mathcal{O}_{s_\gamma} \downarrow M_{s_\gamma}$, with $\mathcal{O}_{s_\gamma} = Q_{I'} \cdot s_\gamma Q_{I'}/Q_{I'}$, the lowest non-trivial left $Q_{I'}$ - orbit in $G'/Q_{I'}$.

Proof. Suppose we have subset I' that satisfies the conditions 1, 2 and 3. Consider the Levi orbit $G'\bar{v}$ for $\bar{v} = vP_J/P_J$. Then the parabolic subgroup $Q_{I'}$ of G' is the

isotropy group of the G' -action on v . Therefore $G'v$ can be considered as the flag variety $G'/Q_{I'}$. Since $W' = (W_{\Theta})_{S'}$ is the Weyl group corresponding to G' , W'' corresponds isomorphically to as a Bruhat poset to the orbit $(W_{\Theta})_{S'}v$. Hence by this poset isomorphism and abuse of notation we can consider points v, w to lie in W'' where $v < w$. Hence we have a Richardson variety $R_{v,w}[I']$ in $G'/Q_{I'}$.

Now by using conditions 1 and 2, we can see that v is minimal in the orbit $(W_{\Theta})_{S'}v$. Hence v corresponds to the identity element in W'' . This implies $R_{v,w}[I']$ is in fact the Schubert variety in $G'/Q_{I'}$ corresponding to the element $w \in W''$. We change notations and set $X_w[I'] = R_{v,w}[I']$.

By condition 2, $w \in W'_{I'} \cdot s_{\gamma}W'_{I'}$ but since $I' \subseteq J_w$, w is the maximal element in $W'_{I'} \cdot s_{\gamma}W'_{I'}$. Now suppose $\mathcal{O}_{s_{\gamma}}$ is the parabolic orbit $Q_{I'}s_{\gamma}Q_{I'}/Q_{I'}$ then closure of $\mathcal{O}_{s_{\gamma}}$ is the Schubert variety $X_w[I']$. Then as described in (4.1.3) in Chapter 4, $X_w[I']$ is the Thom variety $T(\xi_{s_{\gamma}})$ where $\xi_{s_{\gamma}}$ is the line bundle $\mathcal{O}_{s_{\gamma}} \downarrow M_{s_{\gamma}}$.

All that remains to be shown is that in fact $R_{v,w}[I'] = R_{v,w}$. We can consider $R_{v,w}[I'] = R_{v,w} \cap G'\bar{v}$ so $R_{v,w}[I'] \subseteq R_{v,w}$. Also the intervals $[v, w]$ in W'' and $[v, w]$ in W_{Θ}^J are of the same length. This implies $R_{v,w}[I']$ and $R_{v,w}$ are of the same dimension. Since Richardson varieties are irreducible, this forces $R_{v,w}[I'] = R_{v,w}$. \square

Remark 6.1.5. If $R_{v,w} = T(\xi_{s_{\gamma}})$ then $\bar{v} \in R_{v,w}$ corresponds to the point at infinity in $T(\xi_{s_{\gamma}})$. Hence if \bar{v} is a singular point then it is a generic singular point of X_w .

6.2 Richardson variety in a co-minuscule flag variety

In this section we reformulate results due to Brion-Polo in [5] to find the required hypothesis under which we can identify the Richardson variety $R_{v,w}$ with a Thom variety.

6.2.1 Minimal degeneration in a co-minuscule flag variety

Consider the notations given in §6.1.1 and assume G_Θ/P_J is a co-minuscule flag variety from now on. Thus $J = S_\Theta - \{s_t\}$ where s_t is a co-minuscule node in S_Θ . Let X_w be a Schubert variety in G_Θ/P_J for some $w \in W_\Theta^J$. We are interested in looking at minimal degeneration due to the following lemma.

Lemma 6.2.1. Given a Schubert variety X_w in a co-minuscule flag variety G_Θ/P_J then $v \in W_\Theta^J$ is a minimal degeneration of w if and only if \bar{v} in X_w is a generic singularity.

Proof. From [5] and [2] we know that the singular locus of X_w is given by

$$\text{Sing}(X_w) = X_w - P_{J_w}wP_J/P_J.$$

Then by definition, $\bar{v} \in X_w$ is a generic singularity if and only if X_v is a maximal Schubert variety (relative to order of inclusion) in $X_w - P_{J_w}wP_J/P_J$. This implies \bar{v} is a generic singularity if and only if v is a maximal element of the subset $[e, w(W_\Theta)_J] - (W_\Theta)_{J_w}w(W_\Theta)_J$. Thus $\bar{v} \in X_w$ is a generic singularity if and only if v is a minimal degeneration of w . \square

Recall from Theorem 3.1.10 that we can represent the Bruhat poset (W_Θ^J, \leq) isomorphically by the poset $(W_\Theta \cdot \omega_t^\vee, \preceq_r)$ in the co-weight lattice. Further, when we consider a co-weight we can also refer to it as a co-weight position resulting from the node-firing game on ω_t^\vee . Then the definition of minimal degeneration in terms of element of W_Θ^J can be restated in terms of elements of $W_\Theta \cdot \omega_t^\vee$. Set $\omega^\vee = w\omega_t^\vee$. Then $J_w = \{s \in S_\Theta : \omega^\vee(s) \leq 0\}$.

Definition 6.2.2. If $v \in W_\Theta^J$ such that $\nu^\vee = v\omega_t^\vee$ is a maximal element relative to co-weight order ' \preceq_r ' in the set $[e, \omega^\vee] - (W_\Theta)_{J_w}\omega^\vee$ then we call ν^\vee a *minimal degeneration* of ω^\vee .

Remark 6.2.3. By definition v is a minimal degeneration of w if and only if $\nu^\vee = v\omega_t^\vee$ is a minimal degeneration of ω^\vee .

Definition 6.2.4. *Transit node:* If r is a node adjacent to s_0 in the affine Dynkin diagram then r is called a transit node of the Dynkin diagram Γ_{S_Θ} .

Definition 6.2.5. *Descent graph:* A descent graph of the co-weight ω^\vee , is a pair (Γ_D, s_D) where Γ_D is a connected subgraph of Γ_{S_Θ} for some subset D of S and $s_D \in D$ is node of Γ_D such that ω^\vee satisfies the condition given below on the nodes of Γ_D based on its isomorphism type.

1. For Γ_D of all types except type C_l (*typical case*)

$$\omega^\vee(i) = \begin{cases} -1 & \text{if } s_i \text{ is a transit node of } \Gamma_D \\ 1 & \text{if } s_i = s_D \text{ and } s_D \text{ is a co-minuscule node of } \Gamma_D \\ 0 & \text{otherwise} \end{cases}$$

2. For Γ_D of type C_l (*exceptional case*)

$$\omega^\vee(i) = \begin{cases} -1 & \text{if } s_i \text{ is a leaf node of } \Gamma_D \\ 1 & \text{if } s_D = s_i \text{ where } s_D \text{ is an interior node of } \Gamma_D \\ 0 & \text{otherwise} \end{cases}$$

Definition 6.2.6. *Simple descent:* Let ν^\vee be a co-weight given by $\nu^\vee = v\omega_t^\vee$. Then ν^\vee is a simple descent of ω^\vee , denoted by $\omega^\vee \rightarrow \nu^\vee$, if there exists a descent graph (Γ_D, s_D) such that $\nu^\vee - \omega^\vee = \tilde{\alpha}^\vee$, where $\tilde{\alpha}_D$ is the highest root of the root system corresponding to Γ_D .

Remark 6.2.7. In the above definition, we also consider the co-root $\tilde{\alpha}_D^\vee$ as a position in the node-firing game. We do this by setting $\tilde{\alpha}_D^\vee(s_i) = (\tilde{\alpha}_D^\vee, \alpha_i)$ for all $s_i \in S_\Theta$.

We would like to focus on all Richardson varieties $R_{v,w}$ in Co-minuscule flag varieties G_Θ/P_J where $\nu^\vee = v\omega_t^\vee$ is a simple descent of $\omega^\vee = w\omega_t^\vee$ corresponding to a typical descent graph. We know that when G_Θ/P_J is of the simply-laced type or type B_l/B_{l-1} , which we shall call the *general type* of Co-minuscule flag variety for convenience, simple descent with only typical descent graph occurs.

Theorem 6.2.8. For $v, w \in W_\Theta^J$ where W_Θ^J is co-minuscule of general type, let $\nu^\vee = v\omega_t^\vee$ and $\omega^\vee = w\omega_t^\vee$. Then $\omega^\vee \rightarrow \nu^\vee$ is a simple descent (with a typical descent graph) if and only if ν^\vee is a minimal degeneration of ω^\vee .

Proof. Suppose $\nu^\vee = v\omega_t^\vee$ is a simple descent of ω^\vee then there is a descent graph (Γ_D, s_D) of ω^\vee . This implies $\nu^\vee = \omega^\vee + \tilde{\alpha}_D^\vee$, where $\tilde{\alpha}_D^\vee$ is the highest root corresponding to Γ_D .

Firstly $s_{\tilde{\alpha}_D^\vee}\omega^\vee = \omega^\vee - (\omega^\vee, \tilde{\alpha}_D^\vee)\tilde{\alpha}_D^\vee$. By checking the highest root $\tilde{\alpha}_D^\vee$ in each type of Dynkin diagram and using the definition of descent graph we get $(\omega^\vee, \tilde{\alpha}_D^\vee) = -1$. This implies $s_{\tilde{\alpha}_D^\vee}\omega^\vee = \omega^\vee + \tilde{\alpha}_D^\vee$. Hence $\nu^\vee = s_{\tilde{\alpha}_D^\vee}\omega^\vee < \omega^\vee$.

Next we want to show that ν^\vee is maximal in its $(W_\Theta)_{J_w}$ -orbit. That is, we want to show $\nu^\vee(r) \leq 0$ for all $r \in J_w$. By definition of J_w , $\omega_t^\vee(r) \leq 0$ for all $r \in J_w$. Thus we need to check the value of $\nu^\vee(r)$ for all $r \in J_w$ where $\tilde{\alpha}_D^\vee(r) > 0$. Since $\tilde{\alpha}_D^\vee$ is the highest root corresponding to (Γ_D, s_D) , $\tilde{\alpha}_D^\vee(r) = 0$ for all nodes r in J_w that are not in or adjacent to Γ_D . Also $D - \{s_D\} \subseteq J_w$. By inspection of the highest root of the Dynkin diagram in the typical case, we can see that

$$\tilde{\alpha}_D^\vee(r) \text{ is } \begin{cases} 1 & \text{if } r \text{ is a transit node of } \Gamma_D \\ 0 & \text{if } r \text{ is a node in } \Gamma_D - \{s_D\} \text{ that is not a transit node} \\ 0 \text{ or } -1 & \text{if } r \text{ is node of } J_w \text{ that is adjacent to } \Gamma_D \text{ in } \Gamma_{S_\Theta}. \end{cases}$$

Thus for Dynkin diagram Γ_D , $\nu^\vee(r) \leq 0$ for all $r \in J_w$ which implies ν^\vee is maximal in its $(W_\Theta)_{J_w}$ -orbit.

Finally we want to show that if there exists $\nu'^\vee \in W_\Theta \omega_t^\vee$ where ν'^\vee is maximal in its $(W_\Theta)_{J_w}$ -orbit such that $\nu^\vee \leq \nu'^\vee < \omega^\vee$ then $\nu^\vee = \nu'^\vee$. Suppose $\nu^\vee < \nu'^\vee$ then there is a simple co-root α'^\vee such that $s'\nu^\vee \in (W_\Theta)_{J_w} \nu'^\vee$ where $s' = s_{\alpha'}$. This implies $\nu^\vee(s') = 1$. Hence we can say that α'^\vee is a simple co-root such that $s' \notin J_w$ and $\nu^\vee - \nu'^\vee$ contains α'^\vee . Now since ν'^\vee is maximal in $(W_\Theta)_{J_w}$ -orbit and $\nu'^\vee < \omega^\vee$, ν'^\vee is not in the $(W_\Theta)_{J_w}$ -orbit of ω^\vee . Thus we can similarly say that there is a simple co-root α''^\vee such that $\nu'^\vee - \omega^\vee$ contains α''^\vee and $s_{\alpha''}$ is not in J_w . This implies

$$\nu^\vee - \omega^\vee = (\nu^\vee - \nu'^\vee) + (\nu'^\vee - \omega^\vee) \text{ contains two simple co-roots not in } J_w.$$

By definition, $\nu^\vee - \omega^\vee = \tilde{\alpha}_D^\vee$ and by inspection in each case we can see that $\tilde{\alpha}_D^\vee$ contains only one simple co-root not in J_w namely, $\alpha_{s_D}^\vee$, which gives us a contradiction. Hence $\nu^\vee = \nu'^\vee$.

Therefore, ν^\vee is a maximal element in $[e, \omega^\vee] - (W_\Theta)_{J_w} \cdot \omega^\vee$, which implies ν^\vee is a minimal degeneration of ω^\vee .

Conversely, suppose ν^\vee is a minimal degeneration of ω^\vee . Then there is a simple reflection s' such that $\nu^\vee \uparrow s'\nu^\vee \in (W_\Theta)_{J_w} \cdot \omega^\vee$. Since ν^\vee is maximal in its $(W_\Theta)_{J_w}$ -orbit, $\nu^\vee(r) \leq 0$ for all $r \in J_w$. Thus we can select a maximal connected subgraph Γ_D of Γ_{S_Θ} such that $s' \in D$, $D - \{s'\} \subseteq J_w$ and $\nu^\vee(r) = 0$ for all $r \in D - \{s'\}$. Let $\tilde{\alpha}_D$ be the highest root corresponding to D .

First we would like to show that s' is a co-minuscule node of Γ_D . By choosing $\beta = v^{-1}\tilde{\alpha}_D$ in proof of Theorem 3.2.18, we can see that $(\nu^\vee, \tilde{\alpha}_D) = 0, 1$ or -1 . Now highest root $\tilde{\alpha}_D$ is of the form

$$\tilde{\alpha}_D = \sum_{\alpha \in D} a_\alpha \alpha \text{ where } a_\alpha \geq 1 \text{ for all } \alpha \in D.$$

By construction of D , $(\nu^\vee, \tilde{\alpha}_D) = a_{\alpha'}$ where $s' = s_{\alpha'}$. This implies $a_{\alpha'} = 1$. Therefore by definition, s' is a co-minuscule node of Γ_D .

Further by inspection in typical case of Γ_D , α' has coefficient 1 in $\tilde{\alpha}_D^\vee$ also. Define τ to be the co-weight $\tau^\vee = \nu^\vee - \tilde{\alpha}_D^\vee$. Then $\nu^\vee \prec \tau^\vee$ and $\tau^\vee \in (W_\Theta)_{J_w} \omega^\vee$. Therefore $\tau^\vee \leq \omega^\vee$. We would now like to show that $\tau^\vee = \omega^\vee$. That is, we would like to show that $\tau^\vee(r) \leq 0$ for all r in J_w . Since $\tilde{\alpha}_D^\vee$ is the highest root corresponding to Γ_D , by inspection of the highest root of the Dynkin diagram in the typical case, we can see that

$$\tilde{\alpha}_D^\vee(r) \text{ is } \begin{cases} 1 & \text{if } r \text{ is a transit node of } \Gamma_D \\ 0 & \text{if } r \text{ is a node in } \Gamma_D - \{s_D\} \text{ that is not a transit node} \\ 0 \text{ or } -1 & \text{if } r \text{ is in } J_w \text{ that is adjacent to } \Gamma_D \text{ in } \Gamma_{S_\Theta}. \\ 0 & \text{if } r \text{ is in } J_w \text{ but not in or adjacent to } \Gamma_D \end{cases}$$

Further $\nu^\vee(r) \leq 0$ for all $r \in J_w$. Since Γ_D is maximal by construction, $\nu^\vee(r) = -1$ for all r in J_w that are adjacent to Γ_D in Γ_{S_Θ} . Thus we see that $\tau^\vee(r) = \nu^\vee(r) - \tilde{\alpha}_D^\vee(r) \leq 0$ for all $r \in J_w$. This implies τ^\vee is maximal in its $(W_\Theta)_{J_w}$ -orbit. Hence $\tau^\vee = \omega^\vee$.

In type A the transit nodes are also co-minuscule. Suppose s' is a transit node then $\omega^\vee(s') = 0$ which implies $s' \in J_w$ which contradicts our assumption. Hence, s' is an interior minuscule node of Γ_D in type A . Therefore in the typical case

$$\omega^\vee(r) = \begin{cases} -1 & \text{if } r \text{ is a transit node of } \Gamma_D \\ 1 & \text{if } r = s' \text{ and } s' \text{ is a co-minuscule node of } \Gamma_D \\ 0 & \text{otherwise} \end{cases}$$

Therefore we have that (Γ_D, s') is a descent graph of ω^\vee such that $\nu^\vee = \omega^\vee + \tilde{\alpha}_D^\vee$ is a simple descent of ω^\vee . \square

6.2.2 Richardson variety in Co-minuscule flag variety as Thom variety

In the next theorem we specifically consider co-minuscule flag varieties of the general type.

Theorem 6.2.9. Given a Richardson variety $R_{v,w}$ in a general type of co-minuscule flag variety G_Θ/P_J such that v is a minimal degeneration of w then we can identify $R_{v,w}$ with a Thom variety.

Proof. G_Θ/P_J is a co-minuscule flag variety where $J = S_\Theta - \{s_t\}$ where s_t is a co-minuscule node. Set $\nu^\vee = v\omega_t^\vee$ and $\omega^\vee = w\omega_t^\vee$. Since v is a minimal degeneration of w by Theorem 6.2.8 ν^\vee is a simple descent of ω^\vee . Therefore we have a descent graph (Γ_D, s_D) such that $\nu^\vee = \omega^\vee + \tilde{\alpha}_D^\vee$ where $\tilde{\alpha}_D$ is the highest root corresponding to simple system D .

Let I be the subset of J_w given by $I = D - \{s_D\}$. Let $G = G_D$ be the Levi subgroup of parabolic subgroup P_D of G_Θ and Q_D is a maximal parabolic subgroup of G corresponding to the subset I of D . Then by construction of D in the proof of Theorem 6.2.8, we can see that

- $sv(W_\Theta)_J = v(W_\Theta)_J$ for all $s \in I$.
- The left $(W_\Theta)_I$ orbit of $s_D v$ in W_Θ^J contains w .
- $D = I \cup \{s_D\}$ forms a simple system of roots that generates a sub-root system of Θ .

Then by proposition 6.1.4, $R_{v,w}$ is equal to the Thom variety $T(\xi_{s_D})$ where ξ_{s_D} is the line bundle $\mathcal{O}_{s_D} \downarrow M_{s_D}$, with $\mathcal{O}_{s_D} = Q_I \cdot s_D Q_I / Q_I$, the lowest non-trivial left Q_I - orbit in G/Q_I . □

If flag variety G_Θ/P_J is of type C_l/A_{l-1} then the descent graphs you can get are either of type (A_m, s_k) for $1 < k < m$ or of type (C_m, s_m) .

Corollary 6.2.10. Given a Richardson variety $R_{v,w}$ in a co-minuscule flag variety G_Θ/P_J of type C_l/A_{l-1} such that v is a minimal degeneration w such that the corresponding descent graph (Γ_D, s_D) is of type (A_m, s_k) for $1 < k < m$ then we can identify $R_{v,w}$ with a Thom variety.

Proof. Follows the same construction proof as Theorem 6.2.9, since this is just a special case. \square

Remark 6.2.11. The above construction using the descent graph (Γ_D, s_D) doesn't work in the exceptional case. This is because if (Γ_D, s_D) is of type (C_m, s_m) , then by definition $\nu^\vee(s_m) = -1$, where s_m is the leaf node which corresponds to a long root. Therefore if we choose $I = D - \{s_D\}$, the condition 1 of proposition 6.1.4 is not satisfied.

Chapter 7

**COMPUTING LOCAL COHOMOLOGY AT GENERIC
SINGULARITIES FOR SCHUBERT VARIETIES IN
CO-MINUSCULE FLAG VARIETIES**

From Chapter 5 and Chapter 6, we have that the local cohomology of a Schubert variety at a generic singularity can be written in terms of the map $H^{*-2}(M_s) \xrightarrow{c_1(\xi_s)} H^*(M_s)$ using the concept of Thom variety under the hypothesis that the Schubert variety is picked from any co-minuscule flag variety except for type C_l/A_{l-1} . In this Chapter we use the node-firing game described in Chapter 3 to explicitly compute the local cohomology at a generic singularity of such a Schubert variety.

7.1 Notations

Given below are all the notations that we would need in this chapter. We continue using most of notations from the previous chapters.

G_Θ a reductive complex algebraic group with Lie algebra \mathfrak{g}_Θ and root system Θ . Let the corresponding Weyl group be W_Θ with Coxeter generators S_Θ . Denote the Dynkin diagram by Γ_{S_Θ} . The group Γ_{S_Θ} is not of type C .

P_J is a maximal parabolic subgroup of G_Θ , where $J \subseteq S_\Theta$ given by $J = S_\Theta - \{s_t\}$, where s_t is a co-minuscule node of Γ_{S_Θ} .

X_w is a Schubert variety in the flag variety G_Θ/P_J for some $w \in W_\Theta^J$. Element v is a minimal degeneration of w , hence \bar{v} is a generic singularity of X_w . Set $J_w = \{s \in S_\Theta : sw \leq w\}$, that is $P_{J_w} = \text{Stab}X_w$.

(Γ_D, s) is the descent graph of $\omega^\vee = w\omega_t^\vee$ such that $\nu^\vee = v\omega_t^\vee$ is a simple descent of ω^\vee . That is, $\nu^\vee = \omega^\vee + \tilde{\alpha}_D^\vee$, where $\tilde{\alpha}_D$ is the highest root corresponding to D . (We use s instead of s_D for convenience of notation)

G is a the Levi subgroup of parabolic subgroup P_D of G_Θ with corresponding Lie algebra \mathfrak{g} and root system Φ . Let $W = W_D$ be the corresponding Weyl group with Coxeter generators D with Dynkin diagram Γ_D . Γ_D can't be of type C .

Q_I is a maximal parabolic subgroup of G , where $I = D - \{s\}$. By definition s is co-minuscule in Γ_D .

\mathcal{O}_s is the lowest non-trivial parabolic orbit $Q_I s Q_I / Q_I$ in G/Q_I .

M_s is the flag variety L_I/Q_{K_s} where L_I is the Levi subgroup of Q_I . Q_{K_s} is the parabolic subgroup of L_I corresponding to subset K_s which contains all nodes of I that are not adjacent to s . Φ_I be the root system corresponding to L_I with a simple system Δ_I .

$T(\xi_s)$ is the Thom variety where ξ_s is the line bundle $\mathcal{O}_s \downarrow M_s$.

$c_1(\xi_s)$ is the first Chern class of ξ_s ($c_1(\xi_s) \in H^2(M_s)$).

7.2 Cohomology of $\mathcal{O}_s - M_s$ and the flag variety M_s

From Theorem 6.2.9 and Theorem 5.2.3, we know that

$$H_v^*(X_w) \cong H^{*-2m-1}(\mathcal{O}_s - M_s). \quad (7.1)$$

The map $H^*(M_s) \xrightarrow{c_1(\xi_s)} H^{*+2}(M_s)$ denotes the cup product with $c_1(\xi_s)$. Then by Theorem 5.2.4

$$H^n(\mathcal{O}_s - M_s) \cong \begin{cases} \text{Coker}(H^{n-2}(M_s) \xrightarrow{c_1(\xi_s)} H^n(M_s)) & \text{if } n \text{ is even.} \\ \text{Ker}(H^{n-1}(M_s) \xrightarrow{c_1(\xi_s)} H^{n+1}(M_s)) & \text{if } n \text{ is odd.} \end{cases}$$

7.2.1 The map $H^{n-2}(M_s) \xrightarrow{c_1(\xi_s)} H^n(M_s)$

Recall $M_s = L_I/Q_{K_s}$. In order to compute $H^n(\mathcal{O}_s - M_s)$ we need to understand the following map explicitly.

$$\begin{aligned} c_1(\xi_s) : H^{2k-2}(L_I/Q_{K_s}) &\rightarrow H^{2k}(L_I/Q_{K_s}) \\ y &\mapsto c_1(\xi_s) \cup y \end{aligned}$$

The Bruhat decomposition for L_I/Q_{K_s} ([20]) gives us that

$$L_I/Q_{K_s} = \bigsqcup_{\sigma \in W_I^{K_s}} B\sigma Q_{K_s}/Q_{K_s}$$

where $e_\sigma = B\sigma Q_{K_s}/Q_{K_s}$ are the Schubert cells and $X_\sigma = \bar{e}_\sigma$, closure in Zariski topology are the Schubert Varieties of L_I/Q_{K_s} . Let $W_I^{K_s, k}$ be the subset of $W_I^{K_s}$ containing all the minimal coset representatives of length k . Then $\{[X_\sigma]\}_{\sigma \in W_I^{K_s, k}}$ forms the Schubert basis for $H_{2k}(L_I/Q_{K_s}, \mathbb{Z})$, where $[X_\sigma]$ is the homology class of the Schubert variety X_σ . Similarly the cohomology of L_I/Q_{K_s} , $H^{2k}(L_I/Q_{K_s}, \mathbb{Z})$, is free with the Kronecker dual basis $\{y_\sigma\}_{\sigma \in W_I^{K_s, k}}$. For the map $H^{n-2}(L_I/Q_{K_s}) \xrightarrow{c_1(\xi_s)} H^n(L_I/Q_{K_s})$ we can take the Schubert basis of $H^{2k-2}(L_I/Q_{K_s})$ and $H^{2k}(L_I/Q_{K_s})$ given by $\{y_\sigma\}_{\sigma \in W_I^{K_s, k-1}}$ and $\{y_\zeta\}_{\zeta \in W_I^{K_s, k}}$ respectively and then we want to find all the integers $\delta_{\zeta, \sigma}$ such that

$$c_1(\xi_s) \cup y_\sigma = \sum_{\zeta \in W_I^{K_s, k}} \delta_{\zeta, \sigma} y_\zeta$$

for all $\sigma \in W_I^{K_s, k-1}$.

7.2.2 The flag variety M_s

To further understand the map $H^{n-2}(M_s) \xrightarrow{c_1(\xi_s)} H^n(M_s)$, we would like to determine all the relevant flag varieties $M_s = L_I/Q_{K_s}$.

Theorem 7.2.1. All the possible flag varieties M_s for which $T(\xi_s)$ to be isomorphic to R_{vw} are given below.

1. D_4/A_3
2. D_5/A_4
3. E_6/D_5
4. D_l/D_{l-1} for $l \geq 5$
5. $A_l/(A_1 \times A_{l-2})$ for $l \geq 3$
6. B_l/B_{l-1} for $l \geq 2$ ($B_1 = A_1$)
7. $(A_{k-1}/A_{k-2}) \times (A_{l-k}/A_{l-k-1})$ $1 < k < l$

Proof. By the construction given in proof of Theorem 6.2.9, we know that the flag variety L_I/Q_{K_s} depends on the type of descent graph (Γ_D, s) . The relevant relations are $I = D - s$ and K_s is subset of I that contains all nodes except the nodes adjacent to s in Γ_D .

Table 7.1: Typical descent graph (Γ_D, s) with corresponding flag variety M_s for which $T(\xi_s)$ is isomorphic to R_{vw}

(Γ_D, s)	Type of M_s
(A_l, s_k) for $l \geq 2$ $1 < k < l$	$(A_{k-1}/A_{k-2}) \times (A_{l-k}/A_{l-k-1})$
(D_4, s_1)	$A_3/(A_1 \times A_1)$
(D_5, s_1)	D_4/A_3
(D_{l+1}, s_1) for $l \geq 5$	D_l/D_{l-1}
(D_{l+1}, s_l) for $l \geq 4$	$A_l/(A_1 \times A_{l-2})$
(E_6, s_6)	D_5/A_4
(E_7, s_7)	E_6/D_5
(B_{l+1}, s_1) for $l \geq 3$	B_l/B_{l-1}

Given in the table 7.1 are all the typical descent graphs (Γ_D, s) that can be derived from the definition 6.2.5 and the corresponding flag variety L_I/Q_{k_s} . We can easily check that each of the descent graphs listed in the table 7.1 occurs for Schubert varieties in certain co-minuscule flag varieties. Thus in the table we have listed all types of typical descent graph (Γ_D, s) and hence also all the types of the relevant flag variety L_I/Q_{K_s} that occur. \square

Remark 7.2.2. We see that except for type $(A_{k-1}/A_{k-2}) \times (A_{l-k}/A_{l-k-1})$ all others are co-minuscule.

7.3 Co-minuscule M_s and the map $H^{n-2}(M_s) \xrightarrow{c_1(\xi_s)} H^n(M_s)$

We continue using the notations from the previous section. As given in Section 7.2.1, to completely understand the map $H^{n-2}(M_s) \xrightarrow{c_1(\xi_s)} H^n(M_s)$ we want to find all the integers $\delta_{\zeta, \sigma}$ such that

$$c_1(\xi_s) \cup y_\sigma = \sum_{\zeta \in W_I^{K_s, k}} \delta_{\zeta, \sigma} y_\zeta$$

for all $\sigma \in W_I^{K_s, k-1}$. As given in Theorem 7.1, the flag variety M_s is of co-minuscule type except for one case. In this section we will deal with the co-minuscule case. Suppose $\dim_{\mathbb{C}}(M_s) = N$.

Chevalley Coefficients

Let $M_s = L_I/Q_{K_s}$ be a co-minuscule flag variety such that subset $K_s = I - \{s_a\}$ where s_a is a co-minuscule node corresponding to I . Pick an element $\sigma \in W_I^{K_s, k-1}$. Since in a co-minuscule flag variety the Bruhat order and left weak order coincide, if $\zeta > \sigma$ in Bruhat order on $W_I^{K_s}$ such that $\sigma \uparrow \zeta$ then there is a simple root $\alpha \in \Delta_I$ such that $\zeta = s_\alpha \sigma$ and $l(\zeta) = l(\sigma) + 1$ in $W_I^{K_s}$. Hence if y_σ is a basis element of $H^{2k-2}(L_I/Q_{K_s})$ and $s_\alpha : \sigma \uparrow \zeta$ then y_ζ is a basis element of $H^{2k}(L_I/Q_{K_s})$. Hence the

Chevalley formula gives us that

$$c_1(\xi_s) \cup y_\sigma = \sum_{s_\alpha : \sigma \uparrow \zeta} \sigma \omega_a(\alpha^\vee) y_\zeta$$

where ω_a is the fundamental weight corresponding to the co-minuscule node s_a . Therefore for $\sigma \in W_I^{K_s, k-1}$ and $\zeta \in W_I^{K_s, k}$ we have the following.

$$\delta_{\zeta, \sigma} = \begin{cases} \sigma \omega_a(\alpha^\vee) & \text{if } s_\alpha : \sigma \uparrow \zeta \\ 0 & \text{otherwise} \end{cases}$$

We will also call $\delta_{\zeta, \sigma}$ the *Chevalley coefficients*.

Matrix \mathcal{M}_k

Using Chevalley coefficients we want to construct a matrix to represent the map $c_1(\xi_s) : H^{2k-2}(M_s) \rightarrow H^{2k}(M_s)$. For this first we need to specify how to order the elements of $W_I^{K_s, m}$ for $0 \leq m \leq N$. We already have an order (lexicographic) on the simple roots $\alpha_i \in \Delta_I$ as given in the Dynkin diagrams (see [4]). We use this to inductively order the elements of $W_I^{K_s, k}$ as follows.

1. $W_I^{K_s, 0} = \{1\}$ so we have an order when $k = 0$ vacuously.
2. Assume we can order elements of $W_I^{K_s, k-1}$, so we write $W^{K_s, k-1} = \{\sigma_1, \sigma_2, \dots, \sigma_{n_{k-1}}\}$ where $|W_I^{K_s, k-1}| = n_{k-1}$.
3. For each i where $1 \leq i \leq n_{k-1}$, first define set $D_i = \{\alpha \in \Delta_I : s_\alpha \sigma_i > \sigma_i\}$. Now define

$$E_i = D_i - \{\alpha \in D_i : s_\alpha \sigma_m = s_\alpha \sigma_i \text{ for some } m < i\}.$$

If D_i is empty then $k-1 = N$ and $\sigma_i = w_0^j$ for all i .

4. By the ordering on the Δ_I we can write E_i as an ordered sequence $\{\alpha_{(i,1)}, \alpha_{(i,2)}, \dots, \alpha_{(i,r_i)}\}$ for $1 \leq i \leq n_{k-1}$. ($|E_i| = r_i$)

5. From the above steps we know that the number of element in $W_I^{K_s, k}$ is $n_k = r_1 + \cdots + r_{n_{k-1}}$. To order these element we first define sets F_i as follows.

$$\begin{aligned} F_1 &= \{\zeta_1 = s_{\alpha(1,1)}\sigma_1, \cdots, \zeta_{r_1} = s_{\alpha(1,r_1)}\sigma_1\} \\ F_2 &= \{\zeta_{r_1+1} = s_{\alpha(2,1)}\sigma_2, \cdots, \zeta_{r_1+r_2} = s_{\alpha(2,r_2)}\sigma_2\} \\ &\vdots \\ F_{n_{k-1}} &= \{\zeta_{\sum_{i=1}^{n_{k-1}-1} r_i+1} = s_{\alpha(n_{k-1},1)}\sigma_{n_{k-1}}, \cdots, \zeta_{n_k} = \zeta_{\sum_{i=1}^{n_{k-1}} r_i} = s_{\alpha(n_{k-1}, r_{n_{k-1}})}\sigma_{n_{k-1}}\} \end{aligned}$$

Then

$$W_I^{K_s, k} = \bigcup_{1 \leq i \leq n_{k-1}} F_i.$$

Therefore from now on we will always consider the elements of $W_I^{K_s, k}$ with the order described above. Using this order we can correspondingly define the basis of $H^{2k-2}(M_s)$ as $\{y_{\sigma_i} : \sigma_i \in W_I^{K_s, k-1}\}$ and the basis of $H^{2k}(M_s)$ as $\{y_{\zeta_i} : \zeta_i \in W^{K_s, k}\}$. Hence we can define a matrix for the map $c_1(\xi_s) : H^{2k-2}(M_s) \rightarrow H^{2k}(M_s)$ as follows.

$$\mathcal{M}_k = [\mathcal{M}_k(i, j)]_{1 \leq i \leq n_k, 1 \leq j \leq n_{k-1}} \text{ such that } \mathcal{M}_k(i, j) = \delta_{\zeta_i, \sigma_j}$$

where $\sigma_j \in W_I^{K_s, k-1}$ and $\zeta_i \in W^{K_s, k}$.

7.3.1 Node Firing Game and Chevalley Coefficients

If the co-minuscule flag variety M_s is simply laced then we can identify the root system with its dual. This implies the Chevalley coefficients

$$\delta_{\zeta, \sigma} = \begin{cases} \sigma \omega_a^\vee(\alpha) & \text{if } s_\alpha : \sigma \uparrow \zeta \\ 0 & \text{otherwise .} \end{cases}$$

Then the node-firing game described in Chapter 3 gives us a very simple technique to compute the Chevalley coefficients $\delta_{\zeta, \sigma}$ as follows.

Step 1 Consider the fundamental co-weight ω_a^\vee corresponding to the Dynkin diagram Γ_I as an initial position and play the node-firing game on ω_a^\vee . (*This gives*

us the poset $(W_I\omega_a^\vee, \preceq)$ embedded in the co-weight lattice. Also $(W_I\omega_a^\vee, \preceq)$ is isomorphic to the Bruhat poset $(W_I^{K_s}, \leq)$.)

Step 2 For $\sigma \in W_I^{K_s, k-1}$ the node-firing game will give us the co-weight $\sigma\omega_a^\vee$ as a position at the $k - 1$ -th step.

Step 3 For all $\zeta \in W_I^{K_s, k}$ such that $s_\alpha : \sigma \uparrow \zeta$ for some $\alpha \in \Delta_I$ the Chevalley coefficient value $\sigma\omega_a^\vee(\alpha)$ appears as the label of node α of the co-weight position $\sigma\omega_a^\vee$. (In fact, these will correspond to all the positive node-values $\sigma\omega_a^\vee(\alpha)$ since $s_\alpha\sigma > \sigma$.)

If M_s is non-simply laced then we play the node-firing game on the fundamental weight ω_a on the Dynkin diagram corresponding the dual root system Φ_I^\vee and compute the Chevalley coefficients $(\sigma\omega_a(\alpha^\vee))$ using the same steps as given above.

7.4 Computing $H^*(\mathcal{O}_s - M_s)$ when M_s is co-minuscule

In this section we finally compute $H^*(\mathcal{O}_s - M_s)$ for all cases when M_s is co-minuscule (see Theorem 7.1). First we will use the node-firing game as explained in (7.3.1) to construct the poset $(W_I\omega_a, \preceq)$ of the co-weight lattice. Second we will use the poset to compute the Chevalley coefficients $\delta_{\zeta, \sigma}$ and construct the matrices \mathcal{M}_k for $1 \leq k \leq N$ (See (7.3), (7.3), (7.3.1)). Then by Theorem 5.2.4

$$\text{Ker}(\mathcal{M}_i) = H^{2i-1}(\mathcal{O}_s - M_s) \quad (7.2)$$

$$\text{Coker}(\mathcal{M}_i) = H^{2i}(\mathcal{O}_s - M_s) \quad (7.3)$$

All the figures derived from the node-firing game are given in (??). We will use these figures to do case by case analysis in the following sections.

7.4.1 Type D_4/A_3

We have $\dim_{\mathbb{C}}(M_s) = 6$. Playing the node-firing game on ω_1^\vee in D_4 we get figure 7.1.

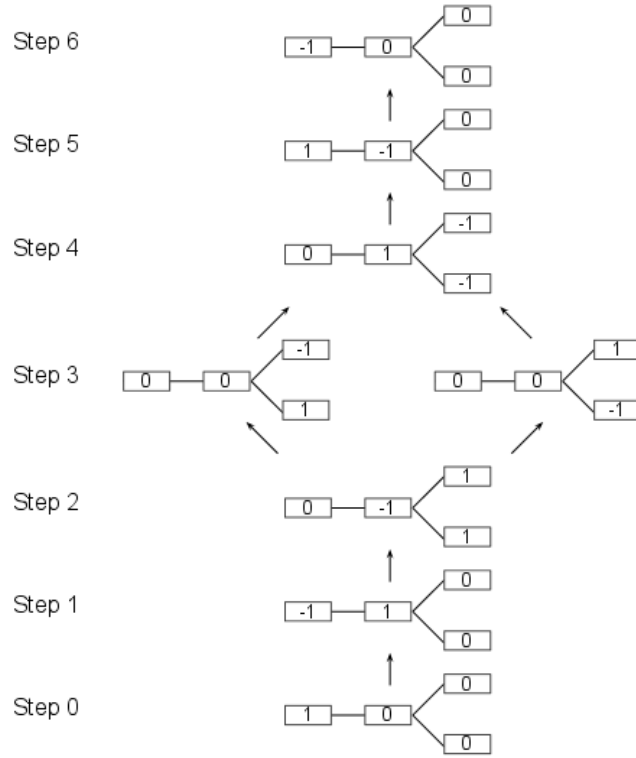
Figure 7.1: Node-firing game on ω_1^y in D_4

Hence we have the following.

$$\mathcal{M}_1 = \mathcal{M}_2 = \mathcal{M}_5 = \mathcal{M}_6 = [1]$$

$$\mathcal{M}_3 = \begin{bmatrix} 1 \\ 1 \end{bmatrix}$$

$$\mathcal{M}_4 = \begin{bmatrix} 1 & 1 \end{bmatrix}$$

Therefore

$$H^i(\mathcal{O}_s - M_s) \cong \begin{cases} \mathbb{Z} & \text{for } i = 0, 6, 7, 13 \\ 0 & \text{otherwise.} \end{cases}$$

7.4.2 D_5/A_4

We have $\dim_{\mathbb{C}}(M_s) = 10$. Playing the node-firing game on ω_5^\vee in D_5 we get figure 7.2.

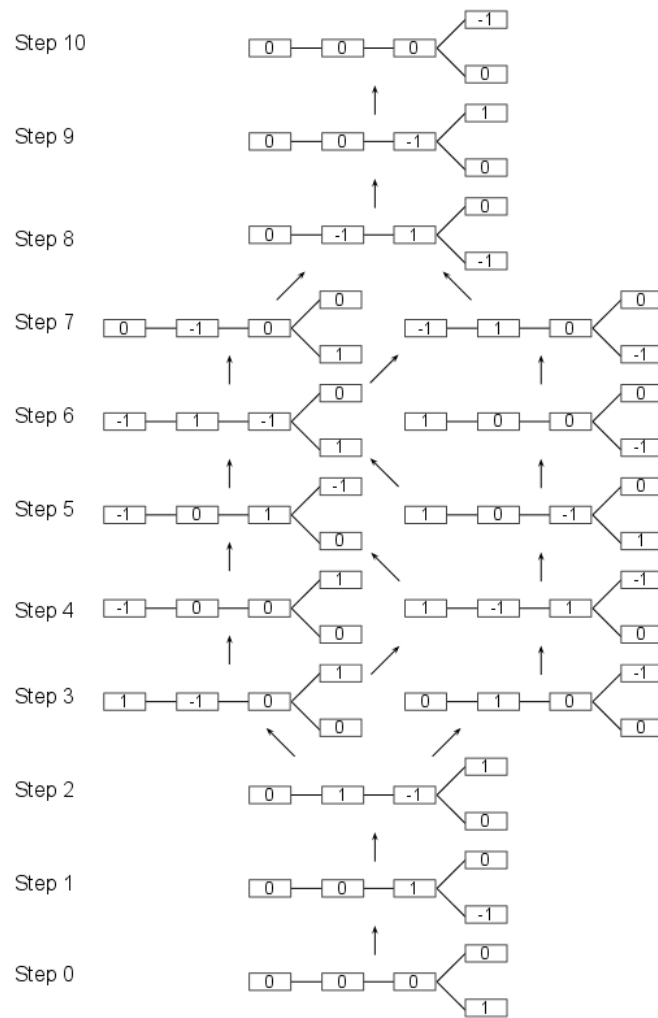

Figure 7.2: Node-firing game on ω_5^\vee in D_5

Hence we have the following.

$$\mathcal{M}_1 = \mathcal{M}_2 = \mathcal{M}_9 = \mathcal{M}_{10} = [1]$$

$$\mathcal{M}_3 = \begin{bmatrix} 1 \\ 1 \end{bmatrix}$$

$$\mathcal{M}_4 = \mathcal{M}_7 = \begin{bmatrix} 1 & 0 \\ 1 & 1 \end{bmatrix}$$

$$\mathcal{M}_5 = \mathcal{M}_6 = \begin{bmatrix} 1 & 1 \\ 0 & 1 \end{bmatrix}$$

$$\mathcal{M}_8 = \begin{bmatrix} 1 & 1 \end{bmatrix}$$

Therefore

$$H^i(\mathcal{O}_s - M_s) \cong \begin{cases} \mathbb{Z} & \text{for } i = 0, 6, 15, 21 \\ 0 & \text{otherwise.} \end{cases}$$

7.4.3 E_6/D_5

We have $\dim_{\mathbb{C}}(M_s) = 16$. Playing the node-firing game on ω_6^\vee in E_6 we get figure 7.3.

Hence we have the following.

$$\mathcal{M}_1 = \mathcal{M}_2 = \mathcal{M}_3 = \mathcal{M}_{14} = \mathcal{M}_{15} = \mathcal{M}_{16} = [1]$$

$$\mathcal{M}_4 = \begin{bmatrix} 1 \\ 1 \end{bmatrix}$$

$$\mathcal{M}_5 = \mathcal{M}_{10} = \mathcal{M}_{11} = \begin{bmatrix} 1 & 0 \\ 1 & 1 \end{bmatrix}$$

$$\mathcal{M}_6 = \mathcal{M}_7 = \mathcal{M}_{12} = \begin{bmatrix} 1 & 1 \\ 0 & 1 \end{bmatrix}$$

$$\mathcal{M}_8 = \begin{bmatrix} 1 & 0 \\ 1 & 1 \\ 0 & 1 \end{bmatrix}$$

$$\mathcal{M}_9 = \begin{bmatrix} 1 & 1 & 0 \\ 0 & 1 & 1 \end{bmatrix}$$

$$\mathcal{M}_{13} = \begin{bmatrix} 1 & 1 \end{bmatrix}$$

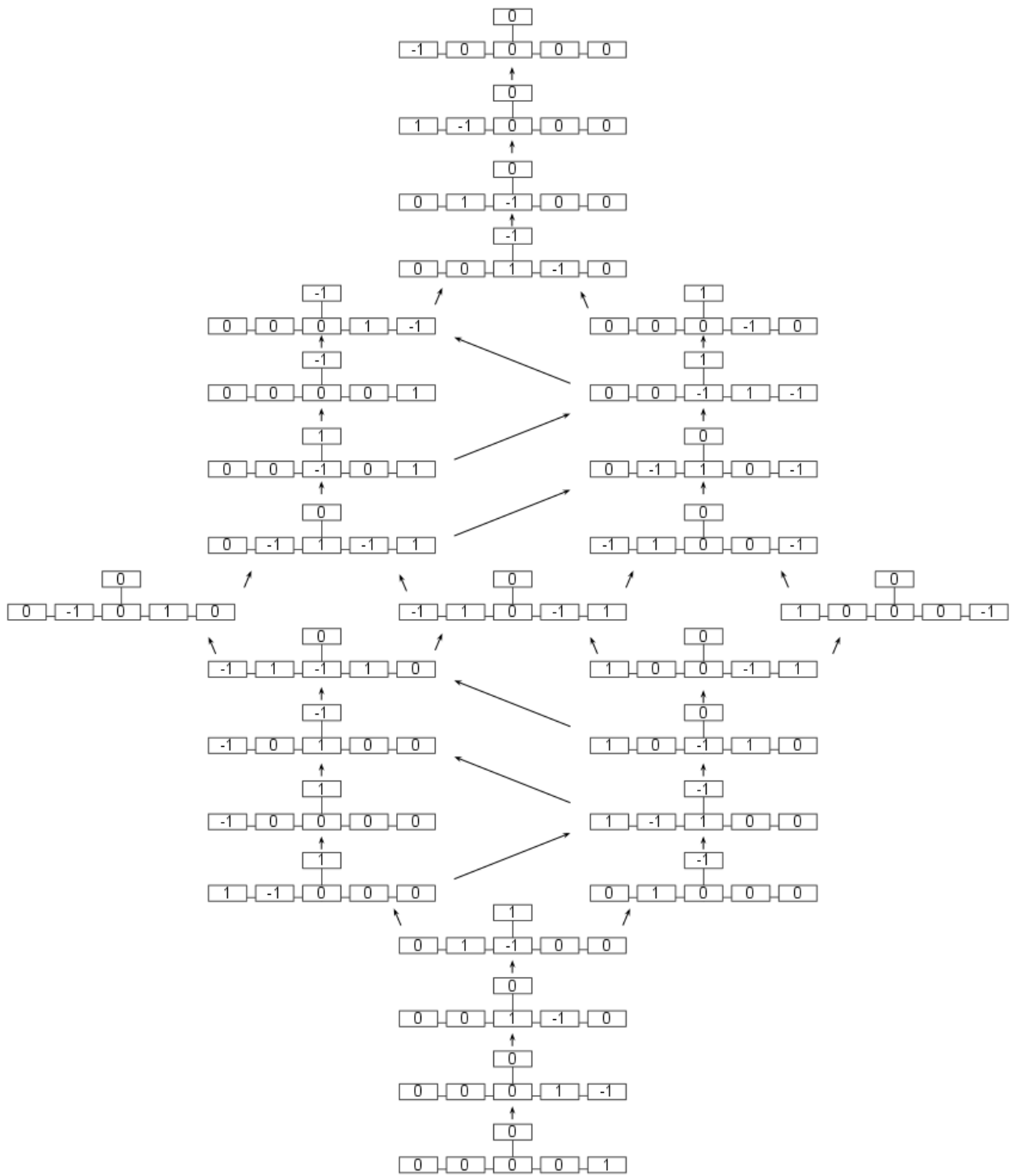
Figure 7.3: Node-firing game on ω_6^\vee in E_6

Therefore,

$$H^i(\mathcal{O}_s - M_s) \cong \begin{cases} \mathbb{Z} & \text{if } i = 0, 8, 16, 17, 25, 33 \\ 0 & \text{otherwise.} \end{cases}$$

7.4.4 D_l/D_{l-1} for $l \geq 5$

We have $\dim_{\mathbb{C}}(M_s) = 2l - 2$. Playing the node-firing game on ω_1^{\vee} in D_l we get figure 7.4.

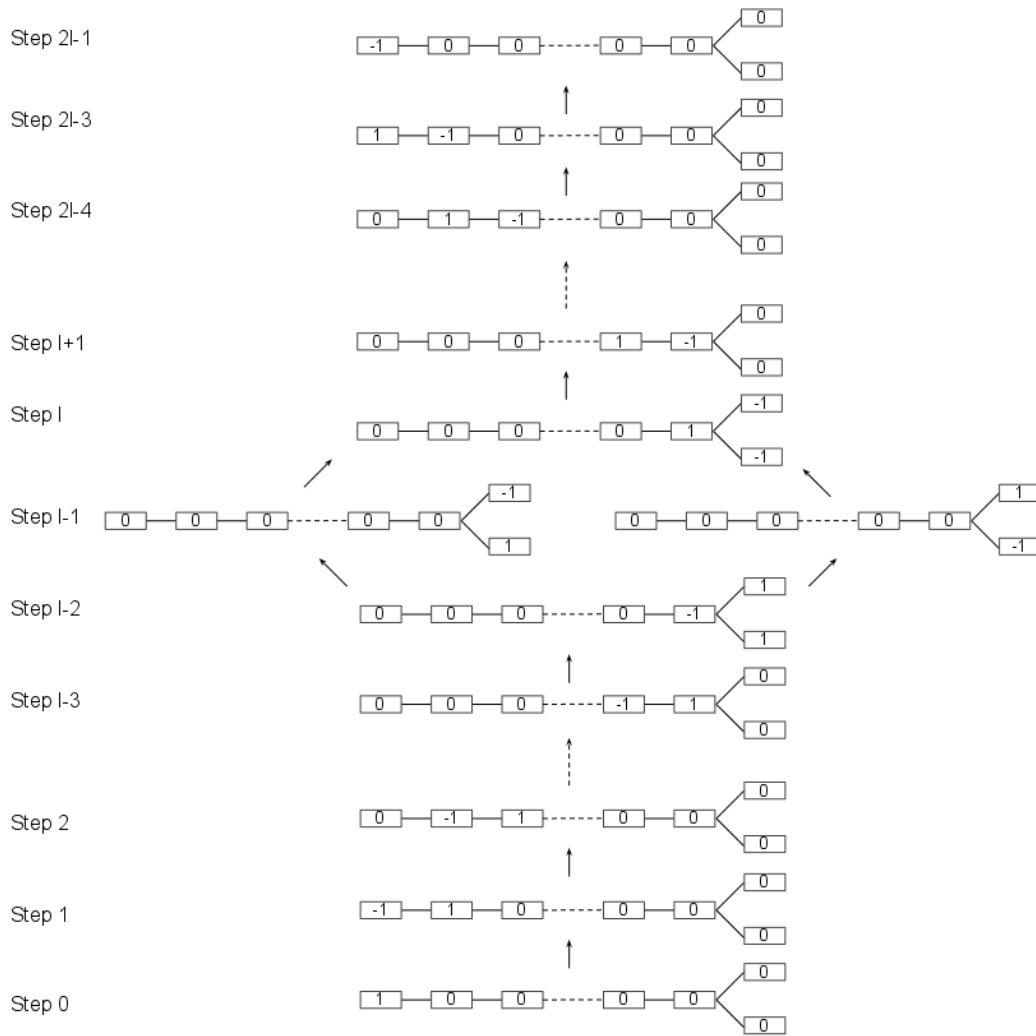

Figure 7.4: Node-firing game on ω_1^{\vee} in D_l

Hence we have the following.

$$\mathcal{M}_i = [1] \text{ for all } 1 \leq i \leq 2l - 2 \text{ and } i \neq l - 1, l$$

$$\mathcal{M}_{l-1} = \begin{bmatrix} 1 \\ 1 \end{bmatrix}$$

$$\mathcal{M}_l = \begin{bmatrix} 1 & 1 \end{bmatrix}$$

Therefore,

$$H^i(\mathcal{O}_s - M_s) \cong \begin{cases} \mathbb{Z} & \text{if } i = 0, 2l - 2, 2l - 1, 4l - 3 \\ 0 & \text{otherwise.} \end{cases}$$

7.4.5 $A_l/(A_1 \times A_{l-2})$ for $l \geq 3$

We have $\dim_{\mathbb{C}}(M_s) = 2l - 2$. We play the node-firing game on ω_2^\vee in A_l . Drawing the corresponding poset diagram is nice for each fixed value of l but a little harder to depict as a general case l , but we can describe the diagram of the game for general case up to the middle step $l - 1$ inductively as given below and rest of the diagram comes by symmetry.

1. The node-firing game on ω_2^\vee in A_3 is given in figure 3.2.
2. Suppose we have constructed the node-firing game on ω_2^\vee in A_{l-1} .
3. The node-firing game on ω_2^\vee in A_l will be identical to the game on A_{l-1} until step $l - 2$.
4. At step $l - 1$ we get one position more in the game on A_l than the one on A_{l-1} as shown below. (The extra position is marked)

Case: l is even

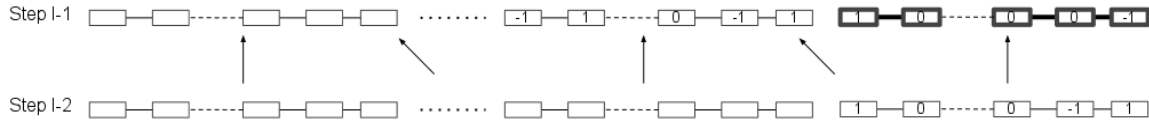

Figure 7.5: Step $l - 1$ of node-firing game on ω_2^\vee in A_3 when l is even

Case: l is odd

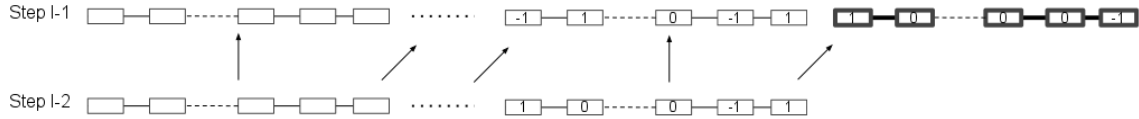

Figure 7.6: Step $l - 1$ of node-firing game on ω_2^\vee in A_3 when l is odd

The above construction works because if we consider the co-weight representation of ω_2^\vee in A_l that is $\omega_2^\vee = (0, 1, 0, \dots, 0, 0)$. The node-firing game on ω_2^\vee in A_l at each step i for $i \leq l - 2$ gives us the position $s_{i+2} \cdots s_2 \omega_2^\vee = (1, 0, \dots, -1, 1, 0, \dots, 0)$. This is the only position with node value 1 at the right-most(α_{i+2}) possible node. Hence the l -th node of resulting positions at each step is always zero up to step $l - 3$, so the steps of the game are identical to playing the node-firing game in A_{l-1} until step $l - 2$. At step $l - 2$ all positions of the node-firing game in A_l have the l -th node zero except the last position $(1, 0, \dots, 0, -1, 1)$. Hence at step $l - 1$ we get one position more, namely $(1, 0, \dots, 0, 0, -1)$, in the game on A_l than in the game on A_{l-1} as shown in the figures above.

Using the above description of the node-firing game on ω_2^\vee in A_l we can derive the matrices \mathcal{M}_k for $1 \leq k \leq 2l - 2$. First define an $(i \times i - 1)$ matrix \mathcal{P}_i and an $(i \times i)$

matrix \mathcal{Q}_i as follows.

$$\mathcal{P}_i = \begin{bmatrix} 1 & 0 & \cdots & 0 \\ 1 & 1 & \ddots & \vdots \\ 0 & 1 & \ddots & 0 \\ \vdots & \ddots & \ddots & 1 \\ 0 & \cdots & & 0 & 1 \end{bmatrix}$$

$$\mathcal{Q}_i = \begin{bmatrix} 1 & 1 & 0 & \cdots & 0 \\ 0 & 1 & 1 & \ddots & \vdots \\ 0 & 0 & \ddots & \ddots & 0 \\ \vdots & \ddots & \ddots & 1 & 1 \\ 0 & \cdots & 0 & 0 & 1 \end{bmatrix}$$

Then we have the following.

$$\mathcal{M}_i = \mathcal{Q}_i \text{ for } 1 \leq i \leq l-1 \text{ and } i \text{ is odd}$$

$$\mathcal{M}_i = \mathcal{P}_i \text{ for } 1 \leq i \leq l-1 \text{ and } i \text{ is even}$$

$$\mathcal{M}_i = \mathcal{M}_{2l-1-i}^T \text{ for } l \leq i \leq 2l-2$$

Let $l = 2m - 1$ if l is odd and $l = 2m$ if l is even. Then

$$H^i(\mathcal{O}_s - M_s) \simeq \begin{cases} \mathbb{Z} & \text{for } i = 0, 4, \dots, 4(m-1), \\ 4l-3-4(m-1), \dots, 4l-7, 4l-3 & \\ 0 & \text{otherwise.} \end{cases}$$

7.4.6 B_l/B_{l-1} for $l \geq 2$

We have $\dim_{\mathbb{C}}(M_s) = 2l - 1$. Here we play the node-firing game on ω_1 of B_1 by considering ω_1 as the co-weight of C_l as explained in (3.2.3) and (7.3.1) and get figure 7.7.

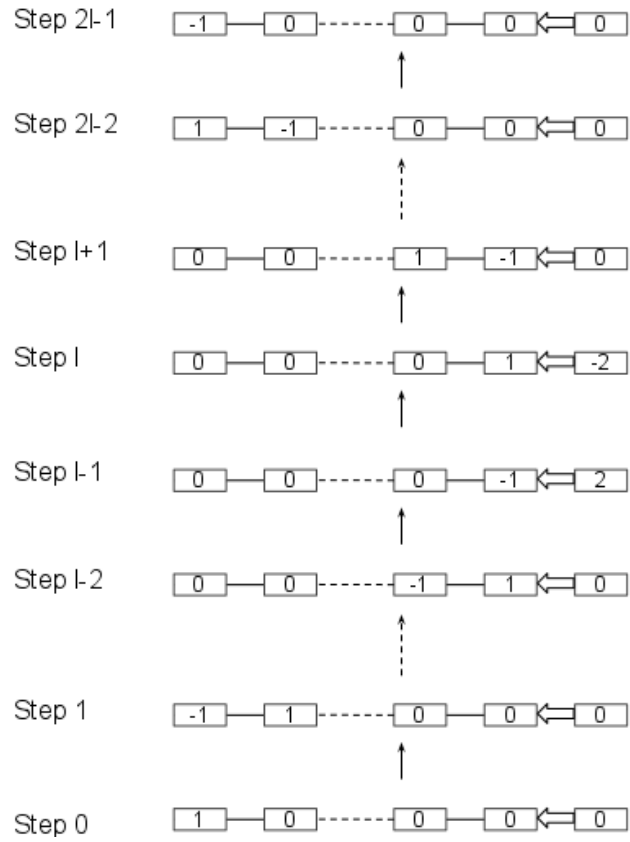
Figure 7.7: Node-firing game on ω_1^V in C_l

Hence we have the following.

$$\mathcal{M}_i = [1] \text{ for } 1 \leq i \leq 2l - 1 \text{ and } i \neq l$$

$$\mathcal{M}_l = [2]$$

Therefore

$$H^i(\mathcal{O}_s - M_s) \cong \begin{cases} \mathbb{Z} & \text{if } i = 0, 4l - 1 \\ \mathbb{Z}/2\mathbb{Z} & \text{if } i = 2l \\ 0 & \text{otherwise.} \end{cases}$$

7.5 Computing $H^*(\mathcal{O}_s - M_s)$ when M_s is of type $(A_{k-1}/A_{k-2}) \times (A_{l-k}/A_{l-k-1})$ for $1 < k < l$.

For simplicity we set $m = k - 1$ and $n = l - k$. Without loss of generality we can assume $m \leq n$. Then we have M_s of type $(A_m/A_{m-1}) \times (A_n/A_{n-1})$ with $1 \leq m, n$. Hence $M_s \cong \mathbb{C}\mathbb{P}^m \times \mathbb{C}\mathbb{P}^n$. Then the line bundle ξ_s is of the form $\lambda_1^* \otimes \lambda_2^* \downarrow \mathbb{C}\mathbb{P}^m \times \mathbb{C}\mathbb{P}^n$. Let $c_1(\lambda_1^*) = y_1$ and $c_1(\lambda_2^*) = y_2$. Then $y_1, y_2 \in H^2(\mathbb{C}\mathbb{P}^m \times \mathbb{C}\mathbb{P}^n)$ and

$$H^*(\mathbb{C}\mathbb{P}^m \times \mathbb{C}\mathbb{P}^n) \cong \mathbb{Z}[y_1, y_2]/(y_1^{m+1}, y_2^{n+1}).$$

The set of ordered basis elements of $H^{2i}(\mathbb{C}\mathbb{P}^m \times \mathbb{C}\mathbb{P}^n)$ is $\mathcal{B}_i = \{y_1^j y_2^k : 0 \leq k \leq i, j+k = i\}$ for $i \geq 0$. Clearly $H^{2i-1}(\mathbb{C}\mathbb{P}^m \times \mathbb{C}\mathbb{P}^n) = 0$ for $i \geq 1$. Also by definition of chern class we have that

$$c_1(\lambda_1^* \otimes \lambda_2^*) = c_1(\lambda_1^*) + c_1(\lambda_2^*) = y_1 + y_2.$$

Now consider the map $c_1(\xi_s) : H^{2i-2}(M_s) \rightarrow H^{2i}(M_s)$. Then for $y_1^j y_2^k \in \mathcal{B}_{i-1}$

$$c_1(\lambda_1^* \otimes \lambda_2^*) \cup y_1^j y_2^k = (y_1 + y_2) \cup y_1^j y_2^k = y_1^{j+1} y_2^k + y_1^j y_2^{k+1}.$$

We now construct the matrix \mathcal{M}_i corresponding to the map $c_1(\xi_s) : H^{2i-2}(M_s) \rightarrow H^{2i}(M_s)$. First define an $(i \times i - 1)$ matrix \mathcal{P}_i and an $(i \times i)$ matrix \mathcal{Q}_i as follows.

$$\mathcal{P}_i = \begin{bmatrix} 1 & 0 & \cdots & 0 \\ 1 & 1 & \ddots & \vdots \\ 0 & 1 & \ddots & 0 \\ \vdots & \ddots & \ddots & 1 \\ 0 & \cdots & & 0 & 1 \end{bmatrix}$$

$$\mathcal{Q}_i = \begin{bmatrix} 1 & 1 & 0 & \cdots & 0 \\ 0 & 1 & 1 & \ddots & \vdots \\ 0 & 0 & \ddots & \ddots & 0 \\ \vdots & \ddots & \ddots & 1 & 1 \\ 0 & \cdots & 0 & 0 & 1 \end{bmatrix}$$

(Also defined in section 7.4.5.) Then we can see that

$$\begin{aligned}\mathcal{M}_i &= \mathcal{P}_{i+1} && \text{for } 1 \leq i \leq m \\ \mathcal{M}_i &= \mathcal{Q}_{m+1} && \text{for } m+1 \leq i \leq n \\ \mathcal{M}_i &= \mathcal{M}_{n+m+1-i}^T && \text{for } n+1 \leq i \leq m+n\end{aligned}$$

By Theorem 5.2.4 we have

$$\begin{aligned}\text{Ker}(\mathcal{M}_i) &= H^{2i-1}(\mathcal{O}_s - M_s) \\ \text{Coker}(\mathcal{M}_i) &= H^{2i}(\mathcal{O}_s - M_s).\end{aligned}$$

Therefore

$$H^i(\mathcal{O}_s - M_s) \cong \begin{cases} \mathbb{Z} & \text{if } i = 0, 2, \dots, 2m, 2n+1, 2n+3, \dots, 2n+2m+1 \\ 0 & \text{otherwise.} \end{cases}$$

7.6 Computing local cohomology $H_v^*(X_w)$

Consider any Schubert variety X_w in a general type co-minuscule flag variety G_Θ/P_J for $w \in (W_\Theta)^J$ as described in Section 7.1. Now suppose $v \in (W_\Theta)^J$ such that \bar{v} is a generic singular point of X_w . In the steps below we summarize the process we have used (from Chapter 6 and 7) to compute the local cohomology of X_w at \bar{v} .

Step (1) We construct the co-weight lattice $(W_\Theta \cdot \omega_t^\vee, \preceq_r)$ using the node-firing game on the initial position ω_t^\vee (See Chapter 3).

Step (2) We find the typical descent graph (Γ_D, s) corresponding to the simple descent $\omega^\vee \rightarrow \nu^\vee$ where $\nu^\vee = v\omega_t^\vee$ and $\omega^\vee = w\omega_t^\vee$ (See Theorem 6.2.8).

Step (3) We find the type of the flag variety M_s corresponding to (Γ_D, s) from the table 7.1.

Step (4) We find the cohomology $H^*(\mathcal{O}_s - M_s)$ corresponding to flag variety M_s from Section 7.4.

Then we have $H_v^*(X_w) \cong H^{*-2m-1}(\mathcal{O}_s - M_s)$ (see Theorem 5.2.3).

7.6.1 Some observations

$H_v^*(X_w)$ when G_Θ/P_J is simply laced and co-minuscule

Suppose the Schubert variety X_w with a generic singularity \bar{v} from a simply laced co-minuscule flag variety. Then from our computation we have that the local cohomology $H_v^*(X_w)$ is ‘torsion-free’.

A theorem of Dale Peterson (see [7]) shows that for Schubert varieties in simply-laced flag varieties of type ADE, rationally smooth implies smooth. This implies our Schubert variety X_w should not be even rationally smooth at the generic singularity \bar{v} . This statement can be verified by tensoring our corresponding computations of $H^*(\mathcal{O}_s - M_s)$ with \mathbb{Q} .

$H_v^*(X_w)$ when G_Θ/P_J is non-simply laced of the type B_l/B_{l-1}

Suppose the Schubert variety X_w with a generic singularity \bar{v} if from a non-simply laced co-minuscule flag variety of the type B_N/B_{N-1} . Then from our computation we have that the local cohomology $H_v^*(X_w)$ always has 2-torsion group.

By tensoring our corresponding computations of $H^*(\mathcal{O}_s - M_s)$ with \mathbb{Q} we also have that the Schubert variety X_w is rationally smooth at the generic singularity \bar{v} .

Chapter 8

**LOCAL COHOMOLOGY AT THE POINT AT INFINITY
OF THOM VARIETIES OVER A CO-MINUSCULE FLAG
VARIETY**

Consider the Thom variety $T(\xi_s)$ corresponding to the line bundle $\xi_s \downarrow M_s$ as described in Chapter 4. Then from (5.2) and (5.2.3) we have that

$$H_\infty^*(T(\xi_s)) \cong H^{*-1}(\mathcal{O}_s - M_s). \quad (8.1)$$

In section 7.4 we have already computed $H^*(\mathcal{O}_s - M_s)$ for each co-minuscule flag variety M_s of the type listed in Theorem 7.2.1 and hence we have the local cohomology $H_\infty^*(T(\xi_s))$ using (8.1). This raises the following question: *What can one say about the local cohomology $H_\infty^*(T(\xi_s))$ when M_s is any co-minuscule flag variety?*

8.1 Computing $H^*(\mathcal{O}_s - M_s)$ for co-minuscule M_s

Listed below are all the types of co-minuscule flag varieties M_s that are not listed in Theorem 7.2.1.

I A_l/A_{l-1} for $l \geq 1$.

II $A_l/(A_k \times A_{l-k-1})$ for $2 \leq k \leq l-2$. For convenience we assume $k \leq l-k-1$.

III C_l/A_{l-1} for $l \geq 3$.

IV D_l/A_{l-1} for $l \geq 6$.

V E_7/E_6

To compute $H^*(\mathcal{O}_s - M_s)$ for type I, II, III, IV and V we can use the same procedure that we used in section 7.4. That is, for each type we use the node-firing game, as explained in (7.3.1), to construct the poset $(W_I\omega_a^\vee, \preceq)$ of the co-weight lattice and then use the poset to compute the Chevalley coefficients $\delta_{\zeta,\sigma}$ and construct the matrices \mathcal{M}_i for $1 \leq i \leq N$ (See (7.3), (7.3.1)). Then by Theorem 5.2.4

$$\begin{aligned} \text{Ker}(\mathcal{M}_i) &= H^{2i-1}(\mathcal{O}_s - M_s) \\ \text{Coker}(\mathcal{M}_i) &= H^{2i}(\mathcal{O}_s - M_s) \end{aligned}$$

For M_s of type I, $T(\xi_s) \cong \mathbb{CP}^{l+1}$ so it is smooth at the point at infinity hence we already know the local cohomology. For M_s of type II, III and IV we need to fix a value of l and also fix value k in type II to do the computations. Unfortunately in types II, III and IV it seems hopelessly difficult to find a pattern for $H^*(\mathcal{O}_s - M_s)$ for a general value of l . Hence computing $H^*(\mathcal{O}_s - M_s)$ for large values of l will be an extremely tedious process if we compute by hand. Instead for types II, III and IV we give a program in Python that computes the matrix \mathcal{M}_i for each i (using the steps of the node-firing game) and use the Sage software to run the program and find its kernel and cokernel (given in section 8.1.2).

8.1.1 $H^*(\mathcal{O}_s - M_s)$ for M_s of type E_7/E_6

We have $\dim_{\mathbb{C}}(M_s) = 27$. We play the node-firing game on ω_7^\vee in E_7 and get the corresponding lattice. This lattice shown in in figure 8.1 until the middle step. We get the rest by symmetry.

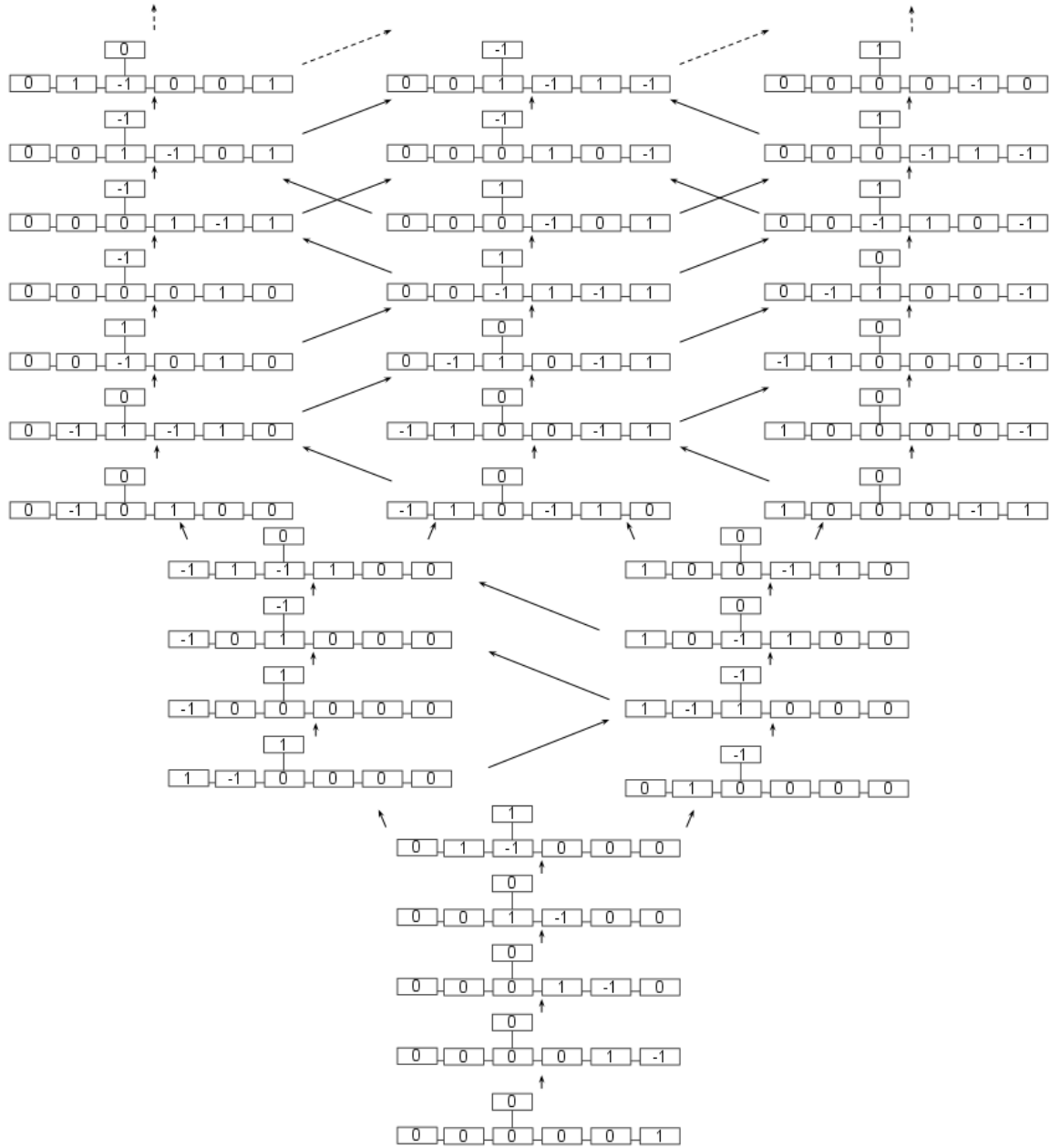

Figure 8.1: Node-firing game on ω_7^\vee in E_7

Hence we have the following.

$$\begin{aligned}
\mathcal{M}_1 &= \mathcal{M}_2 = \mathcal{M}_3 = \mathcal{M}_4 = \mathcal{M}_{24} = \mathcal{M}_{25} = \mathcal{M}_{26} = \mathcal{M}_{27} = [1] \\
\mathcal{M}_5 &= \begin{bmatrix} 1 \\ 1 \end{bmatrix} \\
\mathcal{M}_6 &= \mathcal{M}_{22} = \begin{bmatrix} 1 & 0 \\ 1 & 1 \end{bmatrix} \\
\mathcal{M}_7 &= \mathcal{M}_8 = \mathcal{M}_{20} = \mathcal{M}_{21} = \begin{bmatrix} 1 & 1 \\ 0 & 1 \end{bmatrix} \\
\mathcal{M}_9 &= \begin{bmatrix} 1 & 0 \\ 1 & 1 \\ 0 & 1 \end{bmatrix} \\
\mathcal{M}_{10} &= \mathcal{M}_{18} = \begin{bmatrix} 1 & 1 & 0 \\ 0 & 1 & 1 \\ 0 & 0 & 1 \end{bmatrix} \\
\mathcal{M}_{11} &= \mathcal{M}_{12} = \mathcal{M}_{16} = \mathcal{M}_{17} = \begin{bmatrix} 1 & 0 & 0 \\ 1 & 1 & 0 \\ 0 & 1 & 1 \end{bmatrix} \\
\mathcal{M}_{13} &= \begin{bmatrix} 1 & 1 & 0 \\ 0 & 1 & 0 \\ 0 & 1 & 1 \end{bmatrix} \\
\mathcal{M}_{14} &= \begin{bmatrix} 1 & 1 & 0 \\ 1 & 0 & 1 \\ 0 & 1 & 1 \end{bmatrix} \\
\mathcal{M}_{15} &= \begin{bmatrix} 1 & 0 & 0 \\ 1 & 1 & 1 \\ 0 & 0 & 1 \end{bmatrix}
\end{aligned}$$

$$\mathcal{M}_{19} = \begin{bmatrix} 1 & 1 & 0 \\ 0 & 1 & 1 \end{bmatrix}$$

$$\mathcal{M}_{23} = \begin{bmatrix} 1 & 1 \end{bmatrix}$$

Therefore,

$$H^i(\mathcal{O}_s - M_s) \cong \begin{cases} \mathbb{Z} & \text{if } i = 0, 10, 18, 37, 45, 55 \\ \mathbb{Z}/2\mathbb{Z} & \text{if } i = 28 \\ 0 & \text{otherwise.} \end{cases}$$

8.1.2 Python program to compute $H^*(\mathcal{O}_s - M_s)$ for type II, III and IV

In this section we give a Python program such that given any arbitrary initial co-weight position ω_a^\vee , corresponding to M_s , it computes \mathcal{M}_i for each i and prints the following.

1. Matrix number i of \mathcal{M}_i
2. Elementary divisors of \mathcal{M}_i
3. Nullity of \mathcal{M}_i

This program was written in collaboration with David Sprehn.

```

class coweight(object):
    def __init__(self, diagram, values):
        self.diagram = diagram
        self.values = tuple(values)
        #self.__hash__ = self.values.__hash__

    def __hash__(self):
        return hash(self.values)

    def __eq__(self, other):
        return self.diagram is other.diagram and self.values == other.values

    def fire(self, node):
        assert self.values[node] > 0
        newvals = list(self.values)
        for neigh, arr in self.diagram.adjacency[node]:
            if arr:
                newvals[neigh] += 2 * self.values[node]
            else:
                newvals[neigh] += self.values[node]
        newvals[node] = -newvals[node]
        return coweight(self.diagram, newvals)

    def __repr__(self):
        return repr(self.values)

    def __str__(self):
        return str(self.values)

class diagram(object):
    def __init__(self, numnodes, minuscule, adjlist):

        self.numnodes = numnodes
        self.minuscule = minuscule
        self.adjacency = [ [] for i in range(self.numnodes) ]

        for i,j,arr in adjlist:
            self.adjacency[i].append([j, arr])
            self.adjacency[j].append([i, False])

    def freshcoveight(self):
        values = [(1 if i==self.minuscule else 0) for i in range(self.numnodes)]
        return coweight(self, values)

    def chevalley(self, compute_divisors=True, print_matrices=False):
        oldbasis = [self.freshcoveight()]
        rank = 0

        while True:

```

Figure 8.2: Python program for computing kernel and cokernel of \mathcal{M}_i for all i (part 1/2)

```

newbasis = []
newbasisindices = {}
chemat = []

for j,cw in enumerate(oldbasis):
    for node in range(self.numnodes):
        if cw.values[node] <= 0: continue

        newcw = cw.fire(node)

        try:
            i = newbasisindices[newcw]
        except KeyError:
            newbasisindices[newcw] = len(newbasis)
            newbasis.append(newcw)

        chemat.append( [cw.values[node] if k==j else 0
                       for k in range(len(oldbasis))] )

    else:
        chemat[i][j] = cw.values[node]

# Use sage to compute the dimension of the kernel, and
# the isomorphism type of the cokernel.

if compute_divisors:
    mat = matrix(ZZ, len(newbasis), len(oldbasis), chemat, sparse=True)
    print "\nFor matrix ", rank+1, ":"
    print "Elementary divisors: ", mat.elementary_divisors()
    print "Nullity: ", len(oldbasis) - mat.rank()

if not newbasis: break
oldbasis = newbasis
rank += 1

```

Figure 8.2: Python program for computing kernel and cokernel of \mathcal{M}_i for all i (part 2/2).

From the output of this program we can determine the kernel and cokernel of the matrix \mathcal{M}_i as follows.

- If nullity of \mathcal{M}_i is equal to N then

$$\text{Ker}(\mathcal{M}_i) \cong \oplus_N \mathbb{Z}.$$

(If $N = 0$ then $\text{Ker}(\mathcal{M}_i) = 0$.)

- If the elementary divisors of \mathcal{M}_i are integers a_1, \dots, a_r then

$$\text{Coker}(\mathcal{M}_i) \cong \mathbb{Z}/a_1\mathbb{Z} \oplus \cdots \oplus \mathbb{Z}/a_r\mathbb{Z}.$$

(If $a_j = 0$ then $\mathbb{Z}/a_j\mathbb{Z} = \mathbb{Z}$ and if $a_j = 1$ then $\mathbb{Z}/a_j\mathbb{Z} = 0$.)

Next we specify the value of the co-weight ω_a^\vee for M_s of type II, III and IV and compute $H^*(\mathcal{O}_s - M_s)$ for some initial values of l .

8.1.3 $H^*(\mathcal{O}_s - M_s)$ for M_s of type D_l/A_{l-1} for $l \geq 6$

We set the coweight ω_l^\vee in type D_l/A_{l-1} in Python as follows.

```
class D1A(diagram):
    def __init__(self, l):
        assert l >= 4
        adjlist = [ [i,i+1,False] for i in range(l-2) ] + [[l-3,l-1,False]]
        diagram.__init__(self, l, l-1, adjlist)
```

Figure 8.3: Python program: Co-weight position ω_l^\vee for D_l/A_{l-1}

If we fix $l = 6$ then to compute $H^*(\mathcal{O}_s - M_s)$ we run the program given in figure 8.2 followed with 8.3 and

```
if __name__ == '__main__':
    pass
    D1A(6).chevalley()
```

Figure 8.4: Python program: Run for D_5/A_4

From the output we compute the kernel and cokernel of \mathcal{M}_i for $1 \leq i \leq 16$ as shown in section 8.1.2 and hence compute $H^*(\mathcal{O}_s - M_s)$ (see Theorem 5.2.4) . Similarly we compute $H^*(\mathcal{O}_s - M_s)$ for values $l = 7, 8$. The computations are given below.

For $l = 6$:

$$H^i(\mathcal{O}_s - M_s) \cong \begin{cases} \mathbb{Z} & \text{if } i = 0, 6, 10, 21, 25, 31 \\ \mathbb{Z}/2\mathbb{Z} & \text{if } i = 16 \\ 0 & \text{otherwise} \end{cases}$$

For $l = 7$:

$$H^i(\mathcal{O}_s - M_s) \cong \begin{cases} \mathbb{Z} & \text{if } i = 0, 6, 10, 12, 18, 25, 31, 33, 37, 43 \\ \mathbb{Z}/2\mathbb{Z} & \text{if } i = 16, 22, 28 \\ 0 & \text{otherwise} \end{cases}$$

For $l = 8$:

$$H^i(\mathcal{O}_s - M_s) \cong \begin{cases} \mathbb{Z} & \text{if } i = 0, 6, 10, 12, 14, 18, 20, 24, \\ & 33, 37, 39, 43, 45, 47, 51, 57 \\ \mathbb{Z}/2\mathbb{Z} & \text{if } i = 16, 22, 28, 30, 36, 42 \\ \mathbb{Z}/4\mathbb{Z} & \text{if } i = 26, 32 \\ 0 & \text{otherwise} \end{cases}$$

Remark 8.1.1. Note that for $l = 9$, $H^{33}(\mathcal{O}_s - M_s) \cong \mathbb{Z}/17\mathbb{Z}$.

8.1.4 $H^*(\mathcal{O}_s - M_s)$ for M_s of type C_l/A_{l-1} for $l \geq 3$

We set the coweight ω_l^\vee in type C_l/A_{l-1} in Python as follows.

```
class ClA(diagram):
    def __init__(self, l):
        assert l >= 2
        adjlist = [ [i,i+1,False] for i in range(l-2) ] + [[l-1,l-2,True]]
        diagram.__init__(self, l, l-1, adjlist)
```

Figure 8.5: Python program: Co-weight position ω_l^\vee for C_l/A_{l-1}

If we fix $l = 3$ then to compute $H^*(\mathcal{O}_s - M_s)$ we run the program given in figure 8.2 followed with 8.5 and

```

if __name__ == '__main__':
    pass
    ClA(3).chevalley()

```

Figure 8.6: Python program: Run for C_3/A_2

From the output we compute the kernel and cokernel of \mathcal{M}_i for $1 \leq i \leq 7$ as shown in section 8.1.2 and hence compute $H^*(\mathcal{O}_s - M_s)$ (see Theorem 5.2.4) . Similarly we compute $H^*(\mathcal{O}_s - M_s)$ for values of $l = 4, 5$. The computations are given below.

For $l = 3$:

$$H^i(\mathcal{O}_s - M_s) \cong \begin{cases} \mathbb{Z} & \text{if } i = 0, 6, 7, 13 \\ \mathbb{Z}/2\mathbb{Z} & \text{if } i = 4, 10 \\ 0 & \text{otherwise} \end{cases}$$

For $l = 4$:

$$H^i(\mathcal{O}_s - M_s) \cong \begin{cases} \mathbb{Z} & \text{if } i = 0, 6, 15, 21 \\ \mathbb{Z}/2\mathbb{Z} & \text{if } i = 4, 10, 12, 18 \\ \mathbb{Z}/4\mathbb{Z} & \text{if } i = 8, 14 \\ 0 & \text{otherwise} \end{cases}$$

For $l = 5$:

$$H^i(\mathcal{O}_s - M_s) \cong \begin{cases} \mathbb{Z} & \text{if } i = 0, 6, 25, 31 \\ \mathbb{Z}/2\mathbb{Z} & \text{if } i = 4, 12, 20, 28 \\ \mathbb{Z}/4\mathbb{Z} & \text{if } i = 8, 24 \\ \mathbb{Z} \oplus \mathbb{Z}/2\mathbb{Z} & \text{if } i = 10, 22 \\ \mathbb{Z}/2\mathbb{Z} \oplus \mathbb{Z}/4\mathbb{Z} & \text{if } i = 14, 18 \\ \mathbb{Z}/8\mathbb{Z} & \text{if } i = 16 \\ 0 & \text{otherwise} \end{cases}$$

Remark 8.1.2. Note that for $l = 8$,

$$H^{33}(\mathcal{O}_s - M_s) \cong (\oplus_4 \mathbb{Z}/2\mathbb{Z}) \oplus (\oplus_2 \mathbb{Z}/4\mathbb{Z}) \oplus \mathbb{Z}/136\mathbb{Z}$$

8.1.5 $H^*(\mathcal{O}_s - M_s)$ for M_s of type $A_l/(A_k \times A_{l-k-1})$ for $2 \leq k \leq l - k - 1$

If we fix $k = 2$ then M_s is of type $A_l/(A_2 \times A_{l-3})$ and $l \geq 5$. We set the coweight ω_3^\vee in type $A_l/(A_2 \times A_{l-3})$ in Python as follows.

```
class AlA2(diagram):
    def __init__(self, l):
        assert l >= 4
        adjlist = [ [i, i+1, False] for i in range(l-1) ]
        diagram.__init__(self, l, 2, adjlist)
```

Figure 8.7: Python program: Co-weight position ω_3^\vee for $A_l/(A_2 \times A_{l-3})$

If we fix $l = 5$ then to compute $H^*(\mathcal{O}_s - M_s)$ we run the program given in figure 8.2 followed with 8.7 and

```
if __name__ == '__main__':
    pass
    AlA2(5).chevalley()
```

Figure 8.8: Python program: Run for $A_5/(A_2 \times A_2)$

From the output we compute the kernel and cokernel of \mathcal{M}_i for $1 \leq i \leq 10$ as shown in section 8.1.2 and hence compute $H^*(\mathcal{O}_s - M_s)$ (see Theorem 5.2.4). Similarly we compute $H^*(\mathcal{O}_s - M_s)$ for $l = 6, 7$. The computations are given below.

For $l = 5$:

$$H^i(\mathcal{O}_s - M_s) \cong \begin{cases} \mathbb{Z} & \text{if } i = 0, 4, 6, 13, 15, 19 \\ \mathbb{Z}/2\mathbb{Z} & \text{if } i = 10 \\ 0 & \text{otherwise} \end{cases}$$

For $l = 6$:

$$H^i(\mathcal{O}_s - M_s) \cong \begin{cases} \mathbb{Z} & \text{if } i = 0, 4, 6, 8, 12, 13, 17, 19, 21, 25 \\ \mathbb{Z}/2\mathbb{Z} & \text{if } i = 10, 16 \\ 0 & \text{otherwise} \end{cases}$$

For $l = 7$:

$$H^i(\mathcal{O}_s - M_s) \cong \begin{cases} \mathbb{Z} & \text{if } i = 0, 4, 6, 8, 10, 12, 19, 21, 23, 25, 27, 31 \\ \mathbb{Z}/2\mathbb{Z} & \text{if } i = 16 \\ \mathbb{Z}/3\mathbb{Z} & \text{if } i = 14, 18 \\ 0 & \text{otherwise} \end{cases}$$

As shown above for the case $k = 2$, we can use Sage to do similar computations to find $H^*(\mathcal{O}_s - M_s)$ for M_s of type $A_l/(A_k \times A_{l-k-1})$ for higher values of k by using ω_{k+1}^\vee as the initial co-weight.

8.2 Local cohomology of Thom variety at the point at infinity when M_s is minuscule

If we extend our question to case when M_s is a minuscule flag variety, the corresponding local cohomology can be derived from the co-minuscule computations. To be precise, the local cohomology $H_\infty^*(T(\xi_s))$ can be computed when M_s is minuscule in the simply laced and non-simply laced case as follows.

- If M_s is simply laced (type ADE) then the minuscule and co-minuscule nodes of the corresponding Dynkin diagram coincide. Thus M_s is also a co-minuscule flag variety of the same type, and hence (8.1) and our computations in section 7.4 give us the required local cohomology.
- If M_s is a minuscule flag variety that is not simply laced (type BC) then M_s is isomorphic as a variety to a certain simply-laced co-minuscule flag variety such

that the isomorphism is compatible with the Schubert cell structure (See [29], Section 2.3). To be precise if M_s is minuscule of type C_l/C_{l-1} or B_l/A_{l-1} then we have the following.

$C_l/C_{l-1} \cong A_{2l-1}/A_{2n-2}$: If M_s is of type C_l/C_{l-1} then $M_s \cong \mathbb{C}\mathbb{P}^{2n-1}$. Hence (8.1) and our computations in section 8.7 give us the required local cohomology.

$B_l/A_{l-1} \cong \text{var } D_{l+1}/A_l$: If M_s is of type B_l/A_{l-1} then from (8.1) and our computation in section 8.1.3 we have the required local cohomology.

8.3 Observations: Torsion in local cohomology

1. For M_s of type A_l/A_{l-1} , $T(\xi_s) \cong \mathbb{C}\mathbb{P}^{l+1}$ hence it is smooth at the point at infinity.
2. For M_s of simply laced type D_4/A_3 , D_5/A_4 , E_6/D_5 , D_l/D_{l-1} ($l \geq 5$), $A_l/(A_1 \times A_{l-2})$ ($l \geq 3$) that appear in Chapter 7, $H_\infty^*(T(\xi_s))$ is torsion-free.
3. For M_s of type B_l/B_{l-1} ($l \geq 2$) and E_7/E_6 , $H_\infty^*(T(\xi_s))$ has 2-torsion. This is the only torsion appearing the local cohomology.
4. For M_s of type $A_l/(A_k \times A_{l-k-1})$ ($2 \leq k \leq l-2$), C_l/A_{l-1} ($l \geq 3$) and D_l/A_{l-1} ($l \geq 6$), though we don't have a general formula of $H_\infty^*(T(\xi_s))$, 2-torsion appears in every case that we computed. We also have odd torsion appearing the local cohomology at some higher values of l .

This raises the question, if we are given the usual line bundle ξ_s over a co-minuscule flag variety M_s , is there a condition that gives us the prime p such that p -torsion appears in $H_\infty^*(T(\xi_s))$. We leave this investigation to future work.

BIBLIOGRAPHY

- [1] S. Billey and V. Lakshmibai. *Singular loci of Schubert varieties*. Birkhauser, 2000.
- [2] S.C. Billey and S.A. Mitchell. Smooth and palindromic Schubert varieties in affine Grassmannians. *Journal of Algebraic Combinatorics*, 31(2):169–216, 2010.
- [3] A. Borel. *Linear algebraic groups*. Springer, 1991.
- [4] N. Bourbaki. *Lie groups and Lie algebras*, volume 2. Springer Verlag, 2002.
- [5] M. Brion and P. Polo. Generic singularities of certain Schubert varieties. *Mathematische Zeitschrift*, 231(2):301–324, 1999.
- [6] T. Brocker and T. tom Dieck. *Representations of compact Lie groups*, volume 12. Springer-Verlag, 1985.
- [7] J.B. Carrell and J. Kuttler. Smooth points of T-stable varieties in G/B and the Peterson map. *Inventiones mathematicae*, 151(2):353–379, 2003.
- [8] C. Chevalley. Sur les décompositions cellulaires des espaces G/B . *Algebraic Groups and their Generalizations: Classical Methods*, American Mathematical Society, pages 1–23, 1994.
- [9] R.G. Donnelly. Eriksson’s numbers game and finite Coxeter groups. *European Journal of Combinatorics*, 29(7):1764–1781, 2008.
- [10] K. Eriksson. The numbers game and Coxeter groups. *Discrete mathematics*, 139(1-3):155–166, 1995.
- [11] K. Eriksson. Strong convergence and a game of numbers. *European Journal of Combinatorics*, 17(4):379–390, 1996.
- [12] M. Geck and G. Pfeiffer. *Characters of finite Coxeter groups and Iwahori-Hecke algebras*, volume 21. Oxford University Press, USA, 2000.
- [13] R. Hartshorne. *Algebraic geometry*, volume 52. Springer, 1977.

- [14] Allen Hatcher. *Algebraic topology*. Cambridge University Press, Cambridge, 2002.
- [15] J.E. Humphreys. *Linear algebraic groups*, volume 21. Springer verlag, 1975.
- [16] J.E. Humphreys. *Reflection groups and Coxeter groups*, volume 29. Cambridge Univ Pr, 1992.
- [17] J.E. Humphreys. *Introduction to Lie algebras and representation theory*, volume 9. Springer, 2000.
- [18] D. Juteau. Cohomology of the minimal nilpotent orbit. *Transformation Groups*, 13(2):355–387, 2008.
- [19] S. Kumar. *Kac-Moody groups, their flag varieties, and representation theory*, volume 204. Birkhauser, 2002.
- [20] V. Lakshmibai and N. Gonciulea. *Flag varieties*. Hermann, 2001.
- [21] J.W. Milnor and J.D. Stasheff. *Characteristic classes*. Number 76. Princeton Univ Pr, 1974.
- [22] S.A. Mitchell. Quillens theorem on buildings and the loops on a symmetric space. *Enseign. Math.(2)*, 34(1-2):123–166, 1988.
- [23] S. Mozes. Reflection processes on graphs and Weyl groups. *Journal of Combinatorial Theory, Series A*, 53(1):128–142, 1990.
- [24] R.A. Proctor. Bruhat lattices, plane partition generating functions, and minuscule representations. *European J. Combin*, 5(4):331–350, 1984.
- [25] R.A. Proctor. Minuscule elements of Weyl groups, the numbers game, and d-complete posets. *Journal of Algebra*, 213(1):272–303, 1999.
- [26] Tonny Albert Springer. *Linear algebraic groups*, volume 9. Birkhauser, 1998.
- [27] R. Steinberg. *Lectures on Chevalley groups*. Yale University, 1967.
- [28] J.R. Stembridge. On the fully commutative elements of Coxeter groups. *Journal of Algebraic Combinatorics*, 5(4):353–385, 1996.
- [29] H. Thomas and A. Yong. A combinatorial rule for (co)minuscule Schubert calculus. *Advances in Mathematics*, 222(2):596–620, 2009.

VITA

Sweta Suryanarayan graduated with a Bachelor of Science in Mathematics from SIES College of Arts, Science and Commerce Mumbai, India, in May 2002, received her Master of Science degree in Mathematics from Indian Institute of Technology Bombay, India, in May 2004 and completed her Doctorate of Philosophy in Mathematics at the University of Washington in June 2012.