

©Copyright 2015

Jorge Humberto Rojas Vallejos

Essays on Inequality, Economic Activity and Globalization:
Theory and Evidence

Jorge Humberto Rojas Vallejos

A dissertation
submitted in partial fulfillment of the
requirements for the degree of

Doctor of Philosophy

University of Washington

2015

Reading Committee:

Stephen J. Turnovsky, Chair

Yu-chin Chen

Oksana Leukhina

Program Authorized to Offer Degree:
Economics

University of Washington

Abstract

Essays on Inequality, Economic Activity and Globalization:
Theory and Evidence

Jorge Humberto Rojas Vallejos

Chair of the Supervisory Committee:
Ford and Louisa Van Voorhis Professor of Economics Stephen J. Turnovsky
Economics

The recent increase in trade liberalization has had substantial distributional consequences, although the direction of this relationship and the mechanism driving it has been open to debate. This thesis analyzes the impact of tariff reductions on the dynamics of wealth and income inequality in a growing economy in which agents accumulate assets such as physical capital and internationally traded bonds. This study comprises a combination of theoretical and empirical analyses, supplemented with numerical simulations. These findings suggest that in the long run a tariff reduction will be expansionary and generally associated with a permanent increase in income inequality, the magnitudes of which depend upon the speed at which the tariff reduction is implemented. For plausible parameterization of the models our numerical simulations seem to be generally consistent with empirical evidence. In addition, this thesis presents a formal model on how committees make decisions, an essential element on any trade agreement. Last, I empirically explore the relationship between income inequality and carbon emissions to highlight the relevance and multiple implications of economic inequality in today's society.

TABLE OF CONTENTS

	Page
List of Figures	iii
List of Tables	iv
Chapter 1: Introduction	1
Chapter 2: The Consequences of Tariff Reduction for Economic Activity and Inequality	3
2.1 Macroeconomic Model	7
2.2 Macroeconomic equilibrium	13
2.3 Wealth and income inequality	16
2.4 Numerical analysis	22
2.5 Elimination of tariffs	25
2.6 Conclusions	36
Chapter 3: Tariff Reduction and Income Inequality: Some Empirical Ev- idence	38
3.1 Tariffs and Inequality: Stylized Facts	43
3.2 The Model	46
3.3 Empirical Analysis	53
3.4 Results	62
3.5 Conclusions	76
Chapter 4: The Distributional Consequences of Tariff Liberalization: A Theoretical Approach	78
4.1 The Model	81
4.2 Macroeconomic Equilibrium	89
4.3 Wealth and Income Inequality	95
4.4 Numerical Analysis	99
4.5 Conclusions	106

Chapter 5: The “need to belong” in Search by Committee	107
5.1 Related Literature	110
5.2 The Model	112
5.3 Interior equilibria under the need to belong	117
5.4 Discussion and Conclusion	124
Chapter 6: Carbon Emissions and Inequality: An Intra-temporal Tradeoff with Intertemporal Consequences	127
6.1 Stylized Facts	130
6.2 Empirical Analysis	134
6.3 Results	143
6.4 Conclusions	153
Bibliography	155
Appendix A: Technical Details, Chapter 2	170
A.1 Dynamics of Aggregate Economy	170
A.2 Derivation of Equation (20)	172
Appendix B: Data, Chapter 3	173
B.1 Variables	173
B.2 Descriptive Statistics	175
Appendix C: Technical Details, Chapter 4	177
C.1 Properties of the Short Run	177
C.2 Dynamics of the Aggregate Economy	184
C.3 Linearization of the Relative Wealth Equation	189
Appendix D: Proofs of Lemmas and Propositions, Chapter 5	194
Appendix E: Data and Additional Tables, Chapter 6	198
E.1 Variables	198
E.2 Additional Tables	201

LIST OF FIGURES

Figure Number	Page
2.1 Creditor Nation ($i^* > \beta$). Elimination of tariff from 10%.	28
2.1 Creditor Nation ($i^* > \beta$). Elimination of tariff from 10% (continuation).	29
2.2 Debtor Nation ($\beta > i^*$). Elimination of tariff from 10%.	34
2.2 Debtor Nation ($\beta > i^*$). Elimination of tariff from 10% (continuation).	35
3.1 Stylized Facts	45
4.1 Diagram of the Economic Structure.	82
4.2 Debtor Nation ($i^* > \beta$). Elimination of <i>consumption tariff</i> from 10%.	104
4.3 Creditor Nation ($i^* > \beta$). Elimination of <i>investment tariff</i> from 10%.	105
5.1 Plot of $x_0(z) - z$, as z varies between 0 and 1, for $M = 4, N = 7, \delta = 0.9$. y^* is the unique equilibrium.	117
5.2 Plot of $x(z, \alpha) - z$, as z varies between 0 and 1, for $M = 4, N = 7, \delta = 0.9$ and $\alpha = 0.02$. y_l, y_m and y_r are all equilibrium acceptance threshold in a Markov equilibrium.	118
5.3 The red curve is a plot of $x(z, \alpha)$ as the value of α falls relative to that of the blue curve. The leftmost and the rightmost intersections are seen to move to the respective endpoints, as claimed in Proposition 5.3	122
6.1 Stylized Facts	132
6.2 Heterogeneity Analysis for the Inequality Elasticity of Carbon Emissions	150

LIST OF TABLES

Table Number	Page
2.1 The Benchmark Economy	24
2.2 Steady-state equilibrium responses to tariff reduction 10% to 0.	25
2.3 Steady-state equilibrium responses to tariff reduction from 10% to 0.	26
3.1 Income inequality and tariff reduction panel regressions: Log(Gini)	63
3.2 GMM Estimation: Log(Gini)	66
3.3 SURE Estimation for Inequality by Income Shares	69
3.4 An Indirect Test for the Speed of Tariff Reduction	71
3.5 Long-run Effect: Log. of Avg. Gini 1990 to 2010.	72
3.6 Long Difference Regression: Diff. Log. of Gini 1992 & 2008.	73
3.7 The Effect of Income Inequality on Output: Log. of income per-capita	74
3.8 Output Regressions With No Inequality: Log. of income per-capita	75
4.1 The Benchmark Economy (Example)	100
4.2 Case I: Steady-state equilibrium economic-activity responses.	102
4.3 Case I: Steady-state equilibrium inequality responses.	103
6.1 Descriptive Statistics for Full Sample with ATG data (1961-2010)	135
6.2 Carbon Emissions and Income Inequality Regressions: Log(CO ₂ per-capita)	145
6.3 Dynamic Panel Regressions: Log(CO ₂ per-capita)	147
6.4 Panel Smooth Transition Regression Log(CO ₂ per-capita)	149
6.5 Robustness Checks Panel Regressions Log(CO ₂ per-capita)	151
6.6 Net Income Shares by Quintiles Panel Regressions: Log(CO ₂ per-capita)	152
A.1 Summary Descriptive Statistics	175
A.2 Summary for Income Share by Quintiles	176
E.1 Functional Form	201
E.2 Deciles Panel Regressions.	202
E.3a Cross-correlation	203
E.3b Cross-correlation	204

E.4 Variance Inflation Factors and Tolerance	205
--	-----

ACKNOWLEDGMENTS

Firstly, I would like to express my sincere gratitude to my advisor Prof. Stephen J. Turnovsky for his continuous support throughout my Ph.D. years. His support has been not only academic but also as a person. I thank his patience, motivation, immense knowledge and sense of humor. His guidance helped me during all the time of my research and writing of this thesis. I could not have imagined having a better advisor and mentor for my Ph.D. degree.

Besides my advisor, I would like to thank the rest of my thesis committee: Prof. Murali Agastya (USYD), Prof. Yu-chin Chen and Prof. Oksana Leukhina for their insightful comments and encouragement, but also for the hard question which incentivized me to widen my research from various perspectives.

My sincere thanks also goes to Prof. Philip Brock and Prof. Robert Halvorsen for helping me to develop my economic intuition. As an engineer, I highly appreciate their help in showing me different ways to connect equations and economic narrative. I also thank Dr. Maria Perez for her insightful comments on my empirical work, and Professors James Long and Victor Menaldo from the Political Science Department for discussing with me the importance of the political system for economic activity and inequality. Without their precious support this journey would have been much more difficult and less enriching. My special thanks to Prof. Noam Chomsky at the MIT for meeting me during my first year in the Ph.D. program and encouraging me to study the distributional consequences of globalization.

I thank my fellow classmates for the stimulating discussions, for the sleepless nights we were working together before deadlines during the coursework times, and for all the fun we have had in the last five years. More especially, Samir

Bandaogo, Ibrahim Demir, Thomas Fillebeen, Jenny Ho, Amy Lastuka, Jane Lee, David Oxborrow, Jagori Saha, Inhwan So and Muxin Zhai. I also thank the staff at the department of Economics, more especially Chris Fendrich, Nick Giese, Laura Pflum and Simon Reeve-Parker.

My sincere and special thanks to God, my mother and Zijun. They have been with me in times of happiness and hardship, without their support this document would have not been possible. I thank my friends and professors, Pierre Paul Romagnoli and Leandro Herrera for encouraging me to obtain this Ph.D.

Last but not least, I thank the Chilean workers who have supported me all my life with scholarships since primary school. I also thank my professors Leandro Herrera, Pierre Paul Romagnoli and my teacher Jorge Veliz. Without their support my life would have been extremely different. I thank the funding provided by the BecasChile Scholarship Program of the Chilean Government and the Grover and Creta Ensley Fellowship at the University of Washington.

DEDICATION

to my mother and Zijun

Chapter 1

INTRODUCTION

Inequality matters. Inequality incentivizes people to work hard or discourage them to do so. Inequality has been the source of revolutions and the fall of empires. Understanding the relationship between globalization and inequality is crucial to design economic policy that may effectively promote growth while alleviating inequality. Inequality is not intrinsically good or bad. However, leading economists such as Joseph Stiglitz and Angus Deaton, both Nobel Prize Laureates, have deep concerns about the possible adverse consequences of the large income inequality levels of today's society. But these concerns are not exclusive to academics. Policymakers, politicians and religious leaders have expressed their worry about this topic. Worldwide leaders such as Janet Yellen (Chair of the Fed), Barack Obama (President of the United States) and Pope Francis have made calls to better understand the sources of inequality and design policies to address this issue, while avoiding to hurt the economy.

In this thesis, I analyze the consequences of globalization on inequality with a special focus on tariff liberalization. Chapter 2 investigates by means of a theoretical framework the effects of the reduction of consumption tariffs on economic activity, wealth and income inequality. Chapter 3 shows an empirical analysis of the main results stemming from this theory. Chapter 4 extends this theory to explore the distributional effects of consumption and investment tariffs. Chapter 5 introduces a game theory model that analyzes how conformity may impact the ways committees make decisions. This is essential to understand the policy making process and the time period that reforms take. For instance, the negotiations of the Trans-Pacific Partnership Trade Agreement lasted for approximately seven years, and the terms still need to be voted in the congress of the twelve member

countries. Hence, the importance of modeling this process. Chapter 6 presents an empirical investigation that addresses the relationship between climate change and inequality. Policies that alleviate or worsen inequality may have effects on other important relationships as chapter 6 shows. This demonstrates the complexity of studying inequality and its trade-offs.

I must state that in writing chapters 2, 3 and 4, I had substantial guidance and support from my advisor Prof. Stephen J. Turnovsky. The same applies to Prof. Murali Agastya who worked with me on chapter 5. Chapter 2 is drawn from “The Consequences of Tariff Reduction for Economic Activity and Inequality,” *Open Economies Review* 26 (2015), coauthored with S.J. Turnovsky.

Finally, to facilitate the reading of this work, each chapter is self-contained.

Chapter 2

THE CONSEQUENCES OF TARIFF REDUCTION FOR ECONOMIC ACTIVITY AND INEQUALITY

The last three decades have been a period of dramatic trade liberalization. This has primarily taken the form of a steady reduction in tariffs, accompanied by declining non-tariff barriers, particularly by developing economies. These developments have been associated with an increase in inequality, as [Goldberg and Pavcnik \(2007\)](#) have documented in detail. As these authors have also discussed, due in large part to data limitations, empirical studies have been restricted almost entirely to wage inequality, focusing in particular on the rising wage differential associated with the skill premium. Clearly the consequences of trade liberalization for distributional issues are important. In this paper we address the effects of tariff reduction on both the level of activity and broader measures of income inequality in a neoclassical growth model of an open economy, in which heterogeneous agents accumulate physical capital as well as internationally traded bonds.

In a general setup in which aggregate quantities and their distributions across individuals are simultaneously determined, the analysis of their joint responses to a policy change such as a tariff reduction becomes intractable; see e.g. [Sorger \(2000\)](#).¹ However, if one adopts the prevalent assumption throughout much of contemporary growth theory, specifically, the homogeneity of the underlying utility function, we can exploit the aggregation results due to [Gorman \(1953\)](#), thereby rendering the problem tractable. Under this assumption the macroeconomic equilibrium and distribution are determined sequentially. First, summing over individuals leads to a macroeconomic equilibrium in which aggregate quantities are determined independently of any distributional measures. This equilibrium struc-

¹The interaction between aggregate quantities and their distributions across diverse agents is too complex for one to be able to advance beyond a few general but abstract statements.

ture has led [Caselli and Ventura \(2000\)](#) to characterize the resulting distribution as a representative agent theory of distribution. But the tractability of the aggregation also depends upon the source of the agents heterogeneity, which we take to be their initial endowments of physical capital and internationally traded bonds. In general, endowments are a key source of inequality, as [Piketty \(2011\)](#) and others have recently stressed, and in this international context, agents initial endowments of the two assets seem the most relevant.

Having determined the macroeconomic equilibrium, we then derive the time path for relative wealth across agents, which we can then transform to a measure of wealth inequality. The dynamics of this measure depends on agents' relative labor supplies along the transitional path, and the consequences for the differential savings rates across the distribution of the heterogeneous agents. Finally, the evolution of income inequality is then determined by the interaction of the evolving wealth distribution with the changing share of income from wealth in total personal income.

Using this framework, we first apply it to derive a number of theoretical implications, linking the effects of tariffs on economic activity and inequality. It is straightforward to show that in the long run, a reduction in the tariff on the imported consumption good increases output, employment, capital, and wealth all in the same proportions, which depend upon the degree of openness of the economy in the commodities market. To the extent that the labor supply increases during the transition (in contrast to completely adjusting on impact) this will tend to reduce wealth inequality. In addition to this effect, income inequality is likely to increase due to a reduction in the aggregate consumption expenditure-wealth ratio, and the fact that the rich save relatively more (consume relatively less) than do the poor.

A key factor influencing the impact of tariffs on distribution concerns the speed with which the tariff reduction is implemented. This is important, since in practice there is substantial variation in the rate at which trade liberalizations have pro-

ceeded.² We consider two scenarios. In the first, the tariff reduction is completed instantaneously, and we compare this to the alternative case where it is implemented gradually over time. While the time path affects only the transitional path of the aggregate variables, it has not only *transitional* but also *permanent* consequences for both wealth and income inequality. We find that a gradual reduction in the tariff rate intensifies the effects on wealth inequality, and reduces them on income inequality. This is due to its effect on expectations that people form regarding the future levels of tariffs and labor supply as the economy grows.

Because of the complexity of the model, it is necessary to conduct the dynamic analysis using numerical simulations. In calibrating the model, our intent is to set parameters so as to approximate a plausible initial equilibrium structure that will facilitate our understanding of the channels through which tariffs influence the equilibrium, rather than to replicate any specific economic episode. In particular, we assume an initial average tariff rate of 10%, which approximates the average tax rate of the sample of economies we consider. Starting from that point, we consider both the instantaneous and the gradual elimination of the tariff. In either case we find that in the long run, output and the aggregate capital stock increase by about 2-3%, depending upon parameter values. In contrast, wealth inequality declines by under 1% if the tariff elimination is completed immediately, and by about 1.5-3% if implemented gradually. The comparable changes for income inequality are increases of 2-4% and 1-2%, respectively.

The impact of tariffs on the aggregate economy has been widely studied, both from a theoretical and an empirical standpoint. The earliest studies by [Krugman \(1982\)](#), [Eichengreen \(1981\)](#), and [Kimbrough \(1982\)](#) adopted a Keynesian approach, with arbitrarily specified aggregate behavioral relationships. Subsequent studies by [Sen and Turnovsky \(1989\)](#), [Gardner and Kimbrough \(1989\)](#), [Engel and Kletzer \(1990\)](#), [Brock and Turnovsky \(1993\)](#), [Fender and Yip \(2000\)](#), which adopted an

²For example, we have examined the sample of 45 countries developed by [Forbes \(2000\)](#). There we see substantial variation in the speed with which countries reduced their tariffs over the period 1990-2010, for example. Generally we find that advanced economies tended to reduce them at a much slower rate than have developing countries (approximately 6% per annum versus 12%).

intertemporal perspective, assumed homogeneous agents (or cohorts), and hence none of these studies could address the distributional consequences.

As already noted, over recent years, there has been a growing literature exploring the relationship between trade liberalization policies and inequality, yielding a range of results. For example, [Savvides \(1998\)](#) finds that among less developed countries, more open economies experienced increased income inequality during the late 1980s. However, he found that trade policy has had no effect on income inequality in developed countries. At the same time, [Harrison and Hanson \(1999\)](#) find that trade reform has increased wage inequality for the case of Mexico, which contradicts the prediction by the Heckscher-Ohlin model. Likewise, [Beyer et al. \(1999\)](#) show that for the Chilean economy, openness widens the wage gap between unskilled and skilled workers, which in turn raises income inequality. [Milanovic and Squire \(2005\)](#) find that tariff reduction is associated with more wage inequality in poorer countries, while the reverse applies in richer countries. [Bourguignon and Morrisson \(1990\)](#) analyze the relationship between income distribution and foreign trade in developing economies. They find that endowments in mineral resources, foreign trade distortions as well as secondary schooling are major determinants of differences in income inequality across developing countries. Furthermore, they show that protectionism seems to increase income inequality. [Edwards \(1997\)](#) presents a similar argument. Using data from [Deininger and Squire \(1997\)](#), he shows that the correlation between trade distortions and inequality is positive although not strongly statistically significant. His analysis seems to be robust to different measures of trade openness despite the data limitations. In contrast, [Stewart and Berry \(2000\)](#) claim that liberalization has increased income inequality within nations. They point out that countries' initial conditions and their policy setups play a significant role in how liberalization affects income inequality. They explain that if a country has a high-skilled labor force, then income inequality may be alleviated. However, as is the case of most middle-income countries, if there is concentration of a factor of production that is intensively used and the labor force is not high-skilled, then these countries show a sharp worsening in income distri-

bution. Finally, in a recent paper [Lim and McNelis \(2014\)](#) use a panel to estimate the impact of trade-openness and other controllers on the income Gini coefficient. They find a non-monotonic behavior that depends upon the level of development of the country, analogous to that proposed in [Kuznets \(1955\)](#) seminal contribution. With few exceptions the existing literature focuses on the political economy aspects of trade liberalization rather than the explicit role of tariff reduction, as is the focus here.

The paper is organized as follows. Section 2 sets out the analytical framework, while Section 3 derives and characterizes the macroeconomic equilibrium. Section 4 characterizes the distributions of wealth, and income, and derives the main analytical results. Sections 5 and 6 illustrates these results with numerical simulations describing the effects of the elimination of tariffs. Section 7 concludes, while technical details are presented in Appendix A.

2.1 *Macroeconomic Model*

To begin, we develop a basic neoclassical model of an open economy that consumes two goods. One is produced domestically, while the other is imported and subject to a tariff.³

2.1.1 *Firms*

The domestic good is produced by a single representative firm in accordance with the standard constant returns to scale neoclassical production function

$$Y = F(K, L) \quad F_K > 0, F_L > 0, F_{KK} < 0, F_{LL} < 0, F_{KL} > 0 \quad (2.1)$$

where K , L , and Y denote the economy-wide average stock of capital, labor supply, and output, respectively. Capital depreciates at a constant rate, δ , and factors are paid their respective marginal products so that the return to capital, r , and the

³The model is a modification of [Sen and Turnovsky \(1989\)](#) to allow for heterogeneity among agents. It differs in one other respect from the earlier model in that agents access to the world financial market is subject to frictions.

wage rate, w , are determined by

$$r(K, L) = F_K(K, L) - \delta \quad r_K = F_{KK} < 0, r_L = F_{KL} > 0 \quad (2.2a)$$

$$w(K, L) = F_L(K, L) \quad w_K = F_{LK} > 0, w_L = F_{LL} < 0 \quad (2.2b)$$

2.1.2 Consumers

The economy is populated by a mass 1 of infinitely-lived individuals, indexed by j , who are identical in all respects except for their initial endowments of capital, $K_{j,0}$, and of an internationally traded bond, $B_{j,0}$. In this respect we should note that while there are many sources of heterogeneity, initial endowments are arguably among the most significant. Compelling evidence supporting this view is provided by [Piketty \(2011\)](#). Since we are interested in distribution and inequality we shall focus on individual j 's relative holdings of capital and bonds, $k_j(t) \equiv K_j(t)/K(t)$, $b_j(t) \equiv B_j(t)/B(t)$, where $B(t)$ denotes the economy-wide average stock of bonds. Initial relative endowments, $k_{j,0}$, $b_{j,0}$ have mean 1 and relative standard deviations, $\sigma_{k,0}$, $\sigma_{b,0}$ across agents.⁴ Each agent is also endowed with one unit of time that he can allocate to labor, L_j or enjoy as leisure, l_j , so that $l_j(t) + L_j(t) = 1$. With a continuum of agents, the economy-wide average supply of labor is $L = \int_0^1 L_j dj$ and other aggregates are defined analogously.

Each individual j has lifetime utility that depends upon the following isoelastic function of the domestic consumption good, x_j , the imported consumption good, y_j , and leisure

$$U_j = \int_0^\infty \frac{1}{\gamma} (x_j(t)^\theta y_j(t)^{(1-\theta)} l_j(t)^\eta)^\gamma e^{-\beta t} dt \quad (2.3)$$

$$0 \leq \theta \leq 1, 0 < \eta, -\infty < \gamma \leq 1, \theta\gamma < 1, \eta\gamma < 1$$

where $1/(1 - \gamma)$ is the agent's intertemporal elasticity of substitution, θ measures the relative importance of domestic versus imported consumption, and therefore

⁴These initial endowments can be perfectly arbitrary and therefore consistent with any required non-negativity constraints. As will become apparent in the course of the analysis, the form of the distribution of the initial endowments will be reflected in the evolving distributions of wealth and income.

parameterizes the degree of openness from the consumption standpoint. The exponent, η , parameterizes the relative importance of leisure and β is the subjective discount rate. The remaining restrictions in (2.3) ensure concavity of the utility function in the two consumption goods and leisure.

We assume that the agent chooses his rates of consumption, $x_j(t)$, $y_j(t)$, and rates of accumulation of capital, $K_j(t)$, and traded bonds, $B_j(t)$, so as to maximize (2.3), subject to his instantaneous budget constraint, expressed in terms of units of domestic output as numeraire

$$\begin{aligned} s(t)\dot{B}_j(t) + \dot{K}_j(t) &= w(K, L)L_j(t) + r(K, L)K_j(t) + i\left(\frac{sB}{K}\right)s(t)B_j(t) \\ &\quad - x_j(t) - (1 + \tau(t))s(t)y_j(t) + T_j(t) \end{aligned} \quad (2.4)$$

given his initial endowments of capital and bonds. Equation (2.4) asserts that the agent earns income from supplying labor, renting capital, the interest earned on his holdings of traded bonds, and from lump-sum transfers from the government, T_j . The excess of these income sources over his consumption expenditures (inclusive of the tariff on the imported good) is accumulated in the form of domestic capital goods and foreign bonds, where $s(t)$ denotes the relative price of the foreign good in terms of the domestic good, and $\tau(t)$ denotes the rate of the tariff at time t .

The constraint (2.4) pertains to a lender or borrower according to whether $B_j > 0$ or $D_j \equiv -B_j > 0$, and the equilibrium outcome depends upon the relative magnitudes of the rate of time preference and the given world interest rate, i^* . In either case a key element of the model is that while the economy has access to the international capital market, it faces frictions, expressed by the relationships

$$i\left(\frac{sD}{K}\right) = i^* + \omega\left(\frac{sD}{K}\right) \quad \omega(0) = 0, \omega' > 0, \omega'' > 0 \quad (2.5a)$$

$$i\left(\frac{sB}{K}\right) = i^* - \omega\left(\frac{sB}{K}\right) \quad \omega(0) = 0, \omega' > 0, \omega'' > 0 \quad (2.5b)$$

Equation (2.5a), specifies the familiar convex increasing borrowing costs facing a debtor country.⁵ According to this relationship the borrowing premium is assumed to be an increasing ratio of the country's stock of foreign bonds to capital, which

⁵Many variants of this relationship can be found. A commonly adopted alternative in the

the individual agent, being atomistic, assumes that he cannot influence. Equation (2.5b) expresses a parallel relationship in the case of a creditor nation. In either case, normalizing by the stock of capital means that larger economies are less constrained by the financial friction implicit in (2.5a), (2.5b). The shape of the function $\omega(\cdot)$ reflects the ‘openness’ of the economy with respect to the financial market.

Performing the optimization yields the following first order optimality conditions:

$$\theta x_j^{\gamma\theta-1} y_j^{\gamma(1-\theta)} l_j^{\gamma\eta} = \nu_j \quad (2.6a)$$

$$(1 - \theta) x_j^{\gamma\theta} y_j^{\gamma(1-\theta)-1} l_j^{\gamma\eta} = s(1 + \tau)\nu_j \quad (2.6b)$$

$$\eta x_j^{\gamma\theta} y_j^{\gamma(1-\theta)} l_j^{\gamma\eta-1} = w\nu_j \quad (2.6c)$$

$$r(K, L) = \beta - \frac{\dot{\nu}_j}{\nu_j} \quad (2.6d)$$

$$r(K, L) = i \left(\frac{sB}{K} \right) + \frac{\dot{s}}{s} \quad (2.6e)$$

where ν_j is agent j 's shadow value of wealth, associated with foreign assets. Equations (2.6a)-(2.6c) are standard static efficiency conditions, equating the marginal benefits of consumption and leisure to their respective marginal costs, while (2.6d) and (2.6e) are conventional arbitrage conditions equating the rates of return on investment, lending/borrowing, and the rate of return on consumption. In addition, the following transversality conditions hold

$$\lim_{t \rightarrow \infty} \nu_j K_j e^{-\beta t} = 0; \quad \lim_{t \rightarrow \infty} \nu_j s(t) B_j e^{-\beta t} = 0 \quad (2.7)$$

Dividing (2.6b) and (2.6c) by (2.6a) yields

$$\theta(1 + \tau(t))s(t)y_j(t) = (1 - \theta)x_j(t) \quad (2.8a)$$

$$\theta w(t)l_j(t) = \eta x_j(t) \quad (2.8b)$$

Defining agent j 's total consumption expenditure inclusive of the tariff by $C_j =$

case of debtor countries is to specify the borrowing premium in terms of the ratio of debt to output, as a measure of the country's debt servicing ability. This has similar properties to the chosen specification.

$x_j + (1 + \tau(t))sy_j$, we may write

$$x_j(t) = \theta C_j(t) \quad (2.9a)$$

$$(1 + \tau(t))s(t)y_j(t) = (1 - \theta)C_j(t) \quad (2.9b)$$

$$w(t)l_j(t) = \eta C_j(t) \quad (2.9c)$$

Thus each agent consumes the two consumption goods and leisure in the same proportion.

In practice, programs of trade liberalization, and specifically tariff reductions, are likely to involve extensive negotiations and therefore may well be implemented gradually over an extended period of time. To allow for this we assume that the tariff rate is adjusted gradually from its initial rate, τ_0 , to its post liberalization rate, $\tilde{\tau}$, in accordance with the known path

$$\tau(t) = \tilde{\tau} + (\tau_0 - \tilde{\tau})e^{-\lambda t} \quad (2.10)$$

The parameter, λ , thus defines the speed with which the tariff change occurs and hence the time path it follows. The conventional assumption where the tariff is fully adjusted instantaneously is obtained by letting $\lambda \rightarrow \infty$ in (2.10).⁶ But the more general specification introduced in (2.10) is important. This is because, as we will demonstrate in our numerical simulations, there is a sharp contrast between how λ affects the dynamics of aggregate quantities and of distributions across agents. As one would expect, the time path of tariffs affects the transitional path of the aggregate economy and not the aggregate steady state. But in contrast, it influences both the time paths and the steady-state levels of both wealth and income inequality, thereby having permanent distributional effects.⁷

⁶The assumption that the change in the tariff rate occurs at a constant proportionate rate, and is completed only asymptotically, is made purely for analytical convenience. It is straightforward to generalize (2.10) to the case where the new tariff level is reached in finite time, T . The analysis could also be modified to allow for the tariff reduction to follow a more general time path, and the same general qualitative conclusions would emerge.

⁷The reason for this is the homogeneity of the utility function (2.3) which causes individuals to maintain fixed relative consumption over time. This introduces a zero root into the dynamics of the distributional measures, as a result of which their equilibrium values become path dependent; see [Atolia et al. \(2012\)](#) where this issue is discussed in detail in the context of a Ramsey model.

Taking the time derivatives of (2.9a) - (2.9c), and combining with (2.6d) and (2.6e), we obtain

$$\frac{\dot{x}_j}{x_j} = \frac{\dot{C}_j}{C_j} = \frac{1}{1 - \gamma(1 + \eta)} \left[(1 - \gamma(1 - \theta))r(K, L) + \gamma(1 - \theta)i \left(\frac{sB}{K} \right) - \beta - \eta\gamma \frac{\dot{w}}{w} - \gamma(1 - \theta) \left(\frac{\dot{\tau}}{1 + \tau} \right) \right] \quad (2.11a)$$

$$\frac{\dot{y}_j}{y_j} = \frac{1}{1 - \gamma(1 + \eta)} \left[\gamma(\theta + \eta)r(K, L) + (1 - \gamma(\theta + \eta))i \left(\frac{sB}{K} \right) - \beta - \eta\gamma \frac{\dot{w}}{w} - (1 - \gamma(\theta + \eta)) \left(\frac{\dot{\tau}}{1 + \tau} \right) \right] \quad (2.11b)$$

$$\frac{\dot{l}_j}{l_j} = \frac{1}{1 - \gamma(1 + \eta)} \left[(1 - \gamma(1 - \theta))r(K, L) + \gamma(1 - \theta)i \left(\frac{sB}{K} \right) - \beta - (1 - \gamma) \frac{\dot{w}}{w} - \gamma(1 - \theta) \left(\frac{\dot{\tau}}{1 + \tau} \right) \right] \quad (2.11c)$$

With the right hand side of equations (2.11) being common to all agents, these equations imply that each individual, j , will choose the same growth rate for the two consumption goods and for leisure, in which case these will also equal the corresponding economy-wide growth rate. Thus,

$$\frac{\dot{x}}{x} = \frac{\dot{x}_j}{x_j} = \frac{\dot{C}_j}{C_j} = \frac{\dot{C}}{C}; \quad \frac{\dot{y}}{y} = \frac{\dot{y}_j}{y_j}; \quad \frac{\dot{l}}{l} = \frac{\dot{l}_j}{l_j} \text{ for all } j$$

In particular, we may write $C_j = \varphi_j C$, where $\int_0^1 \varphi_j dj = 1$, and φ_j , which defines agent j 's relative consumption, is constant over time for each j , and is yet to be determined; see footnote 12 below.

2.1.3 The government

To isolate the impact of the tariff, the domestic government is assigned a very minor role, simply levying the tariff on the imported consumption good and then rebating the revenues to consumers.⁸ It issues no debt, nor conducts any other expenditures, maintaining a balanced budget in accordance with

$$T(t) = \tau(t)s(t)y(t) \quad (2.12)$$

We assume that the tariff revenues are rebated uniformly across the agents so that $T_j(t) = T(t)$, for each j .

⁸Another assumption that would also isolate the role of the tariff would be to assume that the tariff revenues are allocated to government expenditure which has no impact on private behavior. Alternatively, if we were to assume that the tariff revenues are spent on some activity that enhances private productivity say, we would have the difficulty of disentangling the effect of the tariff from that the productive effect of the expenditure.

2.2 Macroeconomic equilibrium

Because of the linearity of the optimality conditions in quantities pertaining to the individuals, aggregation is straightforward. Thus, summing (2.9) over all individuals, we can express the equilibrium aggregate economy-wide consumption levels, $x(t)$, $y(t)$, $C(t)$ in terms of aggregate quantities of capital and labor, the relative price, $s(t)$, and the prevailing tariff rate, $\tau(t)$

$$x(t) = \frac{\theta}{\eta} F_L(K, L)(1 - L) \quad (2.13a)$$

$$y(t) = \frac{1 - \theta}{\eta} \frac{F_L(K, L)(1 - L)}{s(t)(1 + \tau(t))} \quad (2.13b)$$

$$C(t) = \frac{1}{\eta} F_L(K, L)(1 - L) \quad (2.13c)$$

To determine the macrodynamic equilibrium, we first assume domestic goods market clearance:

$$F(K, L) = x + Z(s) + I \quad (2.14)$$

where $Z(s)$ denotes the exports of the domestic good and we assume that $Z'(s) > 0$, and $I = \dot{K} + \delta K$ is the aggregate gross investment in the domestic economy.⁹ Using (2.13a), (2.14) can be expressed in the form of the capital accumulation equation

$$\dot{K} = F(K, L) - \frac{\theta}{\eta}(1 - L)F_L(K, L) - Z(s) - \delta K \quad (2.15)$$

Next, aggregating over the individual budget constraints (2.4), noting the linear homogeneity of the production function, using the optimality conditions, (2.13), and the government budget constraint, (2.12), yields the current account relationship

$$\dot{B} = \frac{Z(s)}{s} - \frac{(1 - \theta)}{(1 + \tau(t))s} \frac{(1 - L)}{\eta} F_L(K, L) + i \left(\frac{sB}{K} \right) B \quad (2.16)$$

This equation asserts that the aggregate rate of accumulation of traded bonds equals the balance of trade, given by the first two terms, plus the earnings on the country's net holdings of foreign bonds.

⁹In general, $Z(\cdot)$ is determined abroad by factors that the small country being considered here takes as given. Since we are not trying to explain behavior in the rest of the world, we simply postulate that the quantity of exports increases as the domestic real exchange rate depreciates (i.e. as s increases).

Recalling the return to capital, defined in (2.2a), the arbitrage condition (2.6e) implies

$$\frac{\dot{s}(t)}{s(t)} = F_K(K, L) - \delta - i \left(\frac{sB}{K} \right) \quad (2.17)$$

To obtain the remaining dynamic equation, determining the evolution of the aggregate labor supply, we aggregate (2.11c) over the agents and combine with the relationship

$$\dot{w}/w = [F_{LK}\dot{K} + F_{LL}\dot{L}]/F_L$$

and the adjustment of tariffs (2.10). This is straightforward but tedious, and omitting details, leads to the relationship

$$\begin{aligned} \dot{L} = H(K, L) & \left[(1 - \gamma(1 - \theta))(F_K(K, L) - \delta) + \gamma(1 - \theta)i \left(\frac{sB}{K} \right) - \beta \right] \\ & - (1 - \gamma) \frac{F_{LK}}{F_L} \left(F(K, L) - \frac{\theta}{\eta}(1 - L)F_L - Z(s) - \delta K \right) + (1 - \theta)\gamma\lambda \frac{[\tau(t) - \tilde{\tau}]}{(1 + \tau)} \end{aligned} \quad (2.18)$$

where,

$$H(K, L) = \frac{(1 - L)F_L(K, L)}{(1 - \gamma)(1 - L)F_{LL}(K, L) - (1 - \gamma(1 + \eta))F_L(K, L)}$$

Equations (2.15) - (2.18) summarize the macrodynamic equilibrium in terms of the evolution of $K(t)$, $B(t)$, $s(t)$, and $L(t)$. This describes the “internally” generated aggregate dynamics and is conditional on the evolution of tariffs, $\tau(t)$. To complete the macrodynamic equilibrium we require the externally specified dynamics of tariff adjustment, which are obtained by taking the time derivative of (2.10)

$$\dot{\tau}(t) = \lambda[\tilde{\tau} - \tau(t)] \quad (2.19)$$

Once (2.15)-(2.19) are determined, the corresponding aggregate consumption levels of the domestic and imported consumption goods can be derived from (2.13a) - (2.13c). The key observation is that the aggregate equilibrium is independent of any distributional aspects. This is a consequence of: (i) the homogeneity of the utility function, (ii) the perfect factor markets, and (iii) the assumption that all individuals have equal access to the international financial markets. Under

these assumptions, we can aggregate over the agents, as [Gorman \(1953\)](#) originally noted, giving rise to the “representative agent theory of distribution” as [Caselli and Ventura \(2000\)](#) have stressed more recently.

2.2.1 Steady State

The steady-state equilibrium to this small open economy is attained by setting $\dot{K} = \dot{B} = \dot{s} = \dot{L} = \dot{\tau} = 0$ and is conveniently summarized by the following relationships:

$$F(\tilde{K}, \tilde{L}) - \theta\tilde{C} - Z(\tilde{s}) - \delta\tilde{K} = 0 \quad (2.20a)$$

$$Z(\tilde{s}) - \frac{(1-\theta)}{(1+\tilde{\tau})}\tilde{C} + i\left(\frac{\tilde{s}\tilde{B}}{\tilde{K}}\right)\tilde{B}\tilde{s} = 0 \quad (2.20b)$$

$$F_K(\tilde{K}, \tilde{L}) - \delta = i\left(\frac{\tilde{s}\tilde{B}}{\tilde{K}}\right) \quad (2.20c)$$

$$F_K(\tilde{K}, \tilde{L}) - \delta = \beta \quad (2.20d)$$

$$\tilde{C} = \frac{(1-\tilde{L})}{\eta}F_L(\tilde{K}, \tilde{L}) \quad (2.20e)$$

Combining (2.20c), (2.20d) with (2.5), we see that $\omega\left(\frac{\tilde{s}\tilde{B}}{\tilde{K}}\right) = i^* - \beta$, so that in steady state, the country is a creditor (debtor) according to whether $i^* > (<)\beta$.

With the equilibrium capital-labor ratio being determined by the modified golden-rule condition, (2.20d), we immediately see that the steady-state capital-labor ratio is independent of the tariff.¹⁰ Equation (2.20c) then implies that the same is true for the ratio of the value of traded bonds, expressed in terms of domestic output, $\tilde{B}' \equiv \tilde{s}\tilde{B}$ to capital.

¹⁰This is a consequence of the assumption that the tariff is levied only on consumption goods. This characteristic would no longer hold if imports also include investment goods, which were subject to tariffs; see [Brock and Turnovsky \(1993\)](#).

From (2.20) we derive:

$$d\hat{Y} = d\hat{L} = d\hat{K} = d\hat{B}' = d\hat{V} = -\frac{\tilde{C}(1-\theta)}{1+\tilde{\tau}} \left(\frac{1}{\beta\tilde{V} + F_L\tilde{L} \left[1 + \frac{(1+\theta\tilde{\tau})}{(1+\tilde{\tau})\eta} \right]} \right) \frac{d\tilde{\tau}}{1+\tilde{\tau}} \equiv -\Theta \frac{d\tilde{\tau}}{1+\tilde{\tau}} < 0 \quad (2.21a)$$

$$d\hat{C} = \frac{\tilde{L}}{1-\tilde{L}} \Theta \frac{d\tilde{\tau}}{1+\tilde{\tau}} > 0 \quad (2.21b)$$

$$d\hat{C} - d\hat{V} = \Theta \frac{d\tilde{\tau}}{1+\tilde{\tau}} > 0 \quad (2.21c)$$

$$d\hat{s} = -\frac{1}{Z'} \left[\beta\tilde{K} + F_L\tilde{L} + \frac{\tilde{C}\tilde{L}}{1-\tilde{L}} \right] \Theta \frac{d\tilde{\tau}}{1+\tilde{\tau}} < 0 \quad (2.21d)$$

Thus, long-run capital, labor, output, domestically valued bonds, wealth (expressed in domestic units, $\tilde{K} + \tilde{s}\tilde{B}$) all decline in the same proportion to an increase in the tariff. At the same time, an increase in the tariff in general raises overall long-run consumption expenditures inclusive of the tariff, while lowering the relative price of imported goods.

2.2.2 Transitional dynamics

In Section 6 below we shall analyze the local dynamics following a decrease in the tariff rate, by linearizing eqs. (2.15)-(2.19) about their steady state (2.20). The formal structure of this system is set out in the Appendix, where the unique stable adjustment path is characterized. There it is strongly suggested that the system exhibits saddlepoint behavior in the neighborhood of the steady state.¹¹ Given the specified trajectory for tariffs that may or may not evolve sluggishly, depending upon λ , describes a two-dimensional stable manifold, along which both capital and foreign bonds evolve gradually, while the relative price and employment may respond instantaneously to new information as it comes available.

2.3 Wealth and income inequality

We now analyze the consequences of tariff liberalization for the evolution of wealth and income inequality.

¹¹It is possible by examining the characteristic equation to the dynamic system to derive the formal condition for there to be two positive and two negative eigenvalues. However, such exercises are not only very tedious, and in the end not very illuminating, and we find it much more useful to rely on our simulation results to establish the plausibility of this desired root configuration.

2.3.1 Wealth inequality

To abstract from any direct, but arbitrary, discretionary distributional effects arising from lump-sum transfers, we assume that tariff revenues are rebated uniformly across the agents, namely $T_j(t) = T(t)$, for all j . The wealth of agent j , measured in terms of domestic output is defined by

$$V_j = K_j + sB_j$$

Taking the time derivative of this relation, using the individual's budget constraint, (2.4), the arbitrage condition (2.6e), and the distributional assumption $T_j(t) = T(t)$, the rate of wealth accumulation for agent j is given by

$$\dot{V}_j = r(K, L)V_j(t) - C_j(t) + w(K, L)L_j + T \quad (2.22)$$

Recalling (2.9c) this can be written as

$$\dot{V}_j = r(K, L)V_j(t) + w(K, L) + T - (1 + \eta)C_j(t)$$

and aggregating over all agents j yields

$$\dot{V}(t) = r(K, L)V(t) + w(K, L) + T - (1 + \eta)C(t) \quad (2.23)$$

Next, we define individual j 's share of aggregate wealth to be $v_j \equiv V_j/V$. Taking the time derivative of v_j and combining with (2.22) and (2.23), together with $C_j = \varphi_j C$, we obtain

$$\dot{v}_j = \frac{1}{V} \left([C - T - w(K, L)](v_j - 1) + (1 + \eta)(1 - \varphi_j)C \right) \quad (2.24)$$

Equation (2.24) indicates how the evolution of an individual agent's relative wealth depends upon the evolution of aggregate gross consumption expenditure, the real wage rate, as well as his own specific endowments as reflected in v_j and φ_j . Before solving for $v_j(t)$ we consider some of the steady-state relationships between consumption and wealth. First, considering (2.23) at steady state and using (2.13c), we see that

$$\tilde{C} = \beta\tilde{V} + \tilde{T} + \tilde{w}(\tilde{K}, \tilde{L})\tilde{L} \quad (2.25)$$

so that aggregate steady-state consumption equals the income from wealth, plus wage income, plus the tariff revenue. Using (2.25) and (2.9c), the steady state of (2.24) can be written in the equivalent forms:¹²

$$\tilde{C}_j - \tilde{C} = \frac{\beta}{1 + \eta} \tilde{V} (\tilde{v}_j - 1) = \frac{\beta}{1 + \eta} (\tilde{V}_j - \tilde{V}) \quad (2.26a)$$

$$\tilde{L}_j - \tilde{L} = -\frac{\beta \tilde{V}}{\tilde{w}} \left(\frac{\eta}{1 + \eta} \right) (\tilde{v}_j - 1) = -\frac{\beta}{\tilde{w}} \left(\frac{\eta}{1 + \eta} \right) (\tilde{V}_j - \tilde{V}) \quad (2.26b)$$

From (2.26a) we see that if agent j 's wealth places him above the average, his long-run marginal propensity to consume (inclusive of the tariff) out of his above-average component of his wealth equals $\beta/(1 + \eta)$. Moreover, since (2.25) implies $\tilde{C} > \beta \tilde{V}$, it follows that the average long-run propensity to consume out of wealth exceeds β , implying that wealthier agents save proportionately more and consume proportionately less. From (2.26b) we see that, with a uniform wage, in the long run relatively wealthy people work less and enjoy more leisure.

To analyze the evolution of relative wealth, we linearize (2.24) around the steady state. In doing so, we take account of the fact that $L(t)$ evolves in accordance with (2.18), $w(K, L)$ reflects the accumulation of capital, (2.15), and $T = \tau(1 - \theta)C/(1 + \tau)$. Omitting details, the linearized equation becomes (see Appendix A.2):¹³

$$\dot{v}_j = \beta(v_j(t) - \tilde{v}_j) - \frac{(\tilde{v}_j - 1)}{\tilde{V}} \left[\left(\frac{\tilde{F}_L}{1 - \tilde{L}} \right) (L(t) - \tilde{L}) + \tilde{C} \frac{(1 - \theta)}{(1 + \tilde{\tau})^2} (\tau - \tilde{\tau}) \right] \quad (2.27)$$

The key observation about (2.27) is that the coefficient of $v_j(t) > 0$. Thus in order for the long-run distribution of wealth to be non-degenerate, each agent's relative wealth must remain bounded. To achieve this requires that the solution for $v_j(t)$ is given by the forward-looking solution:¹⁴

$$v_j(t) - 1 = (\tilde{v}_j - 1) \left[1 + \frac{1}{\tilde{V}} \left(\frac{\tilde{F}_L}{1 - \tilde{L}} \right) \int_t^\infty (L(u) - \tilde{L}) e^{-\beta(u-t)} du + \frac{1}{\tilde{V}} \left(\frac{\tilde{s}\tilde{y}}{1 + \tilde{\tau}} \right) \int_t^\infty (\tau(u) - \tilde{\tau}) e^{-\beta(u-t)} du \right] \quad (2.28)$$

¹²This implies $\varphi_j - 1 = (\beta \tilde{V} / \tilde{C})(1 + \eta)^{-1} (\tilde{v}_j - 1)$ and since $\beta \tilde{V} / \tilde{C} < 1$ this implies consumption inequality, which remains constant over time is less than long-run wealth inequality.

¹³The procedure we are following is developed in greater detail in [Turnovsky and García-Peñalosa \(2008\)](#).

¹⁴Otherwise $v_j \rightarrow \pm\infty$, depending upon the agent's initial endowment.

where in writing (2.28) use is made of (2.13b) and (2.13c). Setting $t = 0$ in (2.28) enables us to determine the steady-state relative wealth, \tilde{v}_i in terms of the relative wealth at time 0, namely

$$\tilde{v}_{j-1} = (v_j(0)-1) \left[1 + \frac{1}{\tilde{V}} \left(\frac{\tilde{F}_L}{1-\tilde{L}} \right) \int_0^\infty (L(u) - \tilde{L}) e^{-\beta(u-t)} du + \frac{1}{\tilde{V}} \left(\frac{\tilde{s}\tilde{y}}{1+\tilde{\tau}} \right) \int_0^\infty (\tau(u) - \tilde{\tau}) e^{-\beta(u-t)} du \right]^{-1} \quad (2.29)$$

and letting $t \rightarrow \infty$ in (2.28) we see that $\lim_{t \rightarrow \infty} v_j(t) = \tilde{v}_j$.

In general, the initial jumps in $s(0)$ and $L(0)$ following a structural change, including a tariff decrease, will cause an initial jump in $v_j(0)$ from its previous stationary level. For the simulations we perform this turns out to be extremely small, and it will be exactly zero if initially all agents hold the same portfolio shares, as we shall henceforth assume.¹⁵ Because of the linearity of (2.28) and (2.29) across agents, these equations, which describe a specific agent's relative asset position, can be directly transformed into a corresponding relationship describing the relative distribution of wealth across agents, which therefore serves as a convenient measure of wealth inequality:

$$\sigma_v(t) = \chi(t) \tilde{\sigma}_v \quad (2.30a)$$

$$\sigma_{v,0} = \chi(0) \tilde{\sigma}_v \quad (2.30b)$$

where for notational convenience

$$\chi(t) \equiv \left[1 + \frac{1}{\tilde{V}} \left(\frac{\tilde{F}_L}{1-\tilde{L}} \right) \int_t^\infty (L(u) - \tilde{L}) e^{-\beta(u-t)} du + \frac{1}{\tilde{V}} \left(\frac{\tilde{s}\tilde{y}}{1+\tilde{\tau}} \right) \int_t^\infty (\tau(u) - \tilde{\tau}) e^{-\beta(u-t)} du \right] \quad (2.31)$$

Thus given $\sigma_{v,0}$, (2.30) determines the entire time path of $\sigma_v(t)$.

Written in this way we can see that the dynamics of relative wealth, and therefore its distribution across agents, is driven by the evolution of two factors along the transitional path. The first is labor supply and its impact on the wage rate; the second is the time path over which tariffs are reduced and its impact on import costs. If (i) labor jumps immediately to its new steady state, and (ii) tariffs are fully adjusted immediately [$L(u) = \tilde{L}, \tau(u) = \tilde{\tau}$], then $\chi(t) = 1$

¹⁵That is we assume $K_{j,0}/K_{h,0} = B_{j,0}/B_{h,0}$ for each j, h .

for all $t \geq 0$, and wealth inequality remains unchanged at its initial pre-shock level. Otherwise, to the extent that labor supply increases during the transition, it reduces the real wage and raises the return to capital. This tends to favor wealthier agents, who own more of the capital, causing $\chi(t)$ to decline and leading to a permanent increase in wealth inequality. In contrast, to the extent that the tariff is reduced gradually, this tends to reduce wealth inequality. This is because with only gradual tariff reduction, its expansionary effects occur only gradually, leading to a decline in labor supply and an increase in leisure. Since wealthier agents enjoy proportionately more leisure, they reduce their labor supply by proportionately more [see (2.26b)], causing them to accumulate wealth at a relatively slower rate, thereby reducing wealth inequality. We may summarize this in:

Proposition 2.1 *To the extent that labor supply is increasing (decreasing) during the transition it will lead to a permanent increase (decrease) in wealth inequality. To the extent that the tariff is reduced (increased) gradually it will lead to a permanent decrease (increase) in wealth inequality.*

To compute $v_j(t) - 1$ and $\sigma_v(t)$ along the transitional path we substitute $L(t) - \tilde{L}$ from (A.2d) and $\tau(t) - \tilde{\tau}$ from (2.10) into (2.28) and (2.30). Omitting details, the solution can now be expressed as

$$v_j(t) - 1 = \chi(t)(\tilde{v}_j - 1) \quad (2.32)$$

where evaluating (2.31)

$$\chi(t) = 1 + \frac{\Omega_1}{\mu_1 - \beta} e^{\mu_1 t} + \frac{\Omega_2}{\mu_2 - \beta} e^{\mu_2 t} - \frac{\Omega_3}{\lambda + \beta} e^{-\lambda t} \quad (2.33)$$

where

$$\Omega_1 = -\frac{A_1}{\tilde{V}} \left(\frac{F_L}{1 - \tilde{L}} \right) \kappa_{41}, \quad \Omega_2 = -\frac{A_2}{\tilde{V}} \left(\frac{F_L}{1 - \tilde{L}} \right) \kappa_{42}, \quad \Omega_3 = -\frac{1}{\tilde{V}} \left[\frac{\tilde{s}\tilde{y}}{1 + \tilde{\tau}} + \left(\frac{F_L}{1 - \tilde{L}} \right) \pi_4 \right] (\tau_0 - \tilde{\tau})$$

2.3.2 Income inequality

The income measure we consider is taken to include labor income, interest earned on wealth, and the transfers received from the tariff revenues. Using the arbitrage

condition, agent j 's income is

$$Q_j = r(t)V_j(t) + w(t)L_j(t) + T(t) \quad (2.34)$$

with aggregate income being:

$$Q = r(t)V(t) + w(t)L(t) + T(t) \quad (2.35)$$

so that the agent's relative income, $q_j(t) = Q_j(t)/Q(t)$, is

$$q_j(t) - 1 = \frac{1}{r(t)V(t) + w(t)L(t) + T(t)} [r(t)V(t)(v_j(t) - 1) + w(t)(L_j(t) - L(t))] \quad (2.36)$$

From the relationship (2.9c) and its aggregate, together with the relationship $C_j = \varphi_j C$, yields $w(L_j - L) = -\eta C(\varphi_j - 1)$, where the constant φ_j is given from the steady-state relationship (A.7) in the Appendix; see also footnote 12. Using this relationship, together with (2.32), enables us to relate agent j 's relative income to his relative wealth by

$$q_j(t) - 1 = \varepsilon(t) \left[1 - \left(\frac{\eta}{1 + \eta} \right) \left(\frac{C(t)}{\tilde{C}} \right) \left(\frac{\beta \tilde{V}}{r(t)V(t)} \right) \frac{1}{\chi(t)} \right] (v_j(t) - 1) \quad (2.37)$$

where $\varepsilon(t) \equiv r(t)V(t)/[r(t)V(t) + w(t)L(t) + T(t)]$ denotes the share of income from wealth in total personal income. Because of the linearity of (2.37) across agents, we can express the relationship between relative income and relative wealth in terms of the corresponding standard deviations of their respective distributions, $\sigma_q(t)$, $\sigma_v(t)$ by

$$\sigma_q(t) = \varepsilon(t) \left[1 - \left(\frac{\eta}{1 + \eta} \right) \left(\frac{C(t)}{r(t)V(t)} \right) \left(\frac{\beta \tilde{V}}{\tilde{C}} \right) \frac{1}{\chi(t)} \right] \sigma_v(t) \quad (2.38)$$

Hence the evolution of income inequality depends upon the time paths of two elements. The first is the dynamics of wealth inequality, $\sigma_v(t)$; the second is the dynamics of factor returns as they impact the share of income from net wealth, $\varepsilon(t)$, and the ratio of consumption to income from wealth.

Assuming that the economy starts out in an initial steady state, (2.38) reduces to

$$\tilde{\sigma}_{q,0} = \frac{1}{1 + \eta} \left(\frac{\beta \tilde{V}_0}{\beta \tilde{V}_0 + \tilde{w}_0 \tilde{L}_0 + \tilde{T}_0} \right) \tilde{\sigma}_{v,0} = \left(\frac{\beta}{1 + \eta} \right) \frac{\tilde{V}_0}{\tilde{C}_0} \tilde{\sigma}_{v,0} \quad (2.39)$$

and dividing (2.38) by (2.39) we derive the following expression for income inequality relative to the initial long-run inequality

$$\frac{\sigma_q(t)}{\tilde{\sigma}_{q,0}} = \varepsilon(t) \left[1 - \left(\frac{\eta}{1+\eta} \right) \left(\frac{C(t)}{r(t)V(t)} \right) \left(\frac{\beta\tilde{V}}{\tilde{C}} \right) \frac{1}{\chi(t)} \right] \left(\frac{1+\eta}{\beta} \right) \frac{\tilde{C}_0}{\tilde{V}_0} \frac{\sigma_v(t)}{\tilde{\sigma}_{v,0}} \quad (2.40)$$

In steady state (2.40) simplifies to:

$$\frac{\tilde{\sigma}_q(t)}{\tilde{\sigma}_{q,0}} = \left(\frac{\tilde{C}_0/\tilde{V}_0}{\tilde{C}/\tilde{V}} \right) \frac{\tilde{\sigma}_v}{\tilde{\sigma}_{v,0}} \quad (2.41)$$

so that long-run income inequality varies positively with long-run changes in wealth inequality and inversely with changes in the gross consumption-wealth ratio. Recalling (2.21) we may state

Proposition 2.2 *By reducing the gross consumption-wealth ratio a tariff reduction will increase long-run income inequality. To the extent that it decreases (increases) wealth inequality it will decrease (further increase) income inequality.*

Thus, the overall effect will need to take account of both these effects. As our numerical simulations suggest, although wealth inequality is likely to decline, this effect is dominated by the response of the consumption-wealth ratio, so that long-run income inequality rises.

2.4 Numerical analysis

Being a relatively high order system, to study the local dynamics of the economy in response to a reduction in tariffs, we return to the linearized system (A.2a)-(A.2d), which we solve numerically. The simulations are based on the constant elasticity utility function, (2.3), together with the Cobb-Douglas production function, $F(K, L) = AK^\alpha L^{1-\alpha}$, and the constant elasticity export function, $Z(s) = bs^c$. In addition, we assume the borrowing and lending constraints

$$i \left(\frac{sD}{K} \right) = i^* + \xi [e^{a(sD/K)} - 1] \quad (2.42)$$

$$i \left(\frac{sB}{K} \right) = i^* - \xi [e^{a(sB/K)} - 1] \quad (2.43)$$

which have the properties as specified by (2.5).

2.4.1 Calibration

The parameters used to calibrate the benchmark economy are summarized in Table 2.1, which represents a typical emerging or developed open economy. We consider two different scenarios: Case I where ($i^* > \beta$) and the country is a lender, and Case II where ($i^* < \beta$) and it is a debtor, with our choices of β and i^* yielding plausible examples of both cases. This is of some significance since certain aspects of the dynamics and long-run adjustments are sensitive to the economy's net asset position.¹⁶ Setting $\gamma = -1.5$ implies an intertemporal elasticity of substitution equal to 0.4, well within the range of empirical estimates, while the other preference parameter, η , is chosen to ensure a plausible equilibrium allocation of time to leisure of around 0.70, is also consistent with the available evidence.¹⁷ The relative weights of domestic versus imported consumption $\theta = 0.5, 0.75$ span the range of imports-GDP ratios of most emerging and developed economies, while the export demand elasticity $b = 3$ is consistent with empirical evidence.¹⁸ The borrowing premium $a = 0.15$ and the weight on the borrowing premium ξ are chosen in order to attain a plausible debt to output ratio for debtor countries, and likewise for creditor economies. The base tariff is set at 10%, which is close to the average of low and middle income countries for around 1990; see World Bank (2014). In both cases it generates a tax revenue of around 3.9% of GDP, which is also consistent with the revenues generated by tariffs.

The resulting macroeconomic equilibrium is summarized in Table 2.2. Row 1 in the first panel of Part A reports the key steady-state equilibrium values for the case of the creditor economy, taking $\theta = 0.75$ as the benchmark allocation of consumption goods. It implies an equilibrium capital-output ratio of 4 and a

¹⁶In both cases we find that the equilibrium is a saddlepoint, implying that there is a unique stable adjustment path.

¹⁷It implies an aggregate Frisch elasticity of around 1.2 well within the range adopted in macroeconomic simulations; see Keane and Rogerson (2012). The inconsistency between these aggregate values and the smaller estimates obtained from the micro data is an issue currently occupying the attention of labor economists. Keane and Rogerson (2012) offer a reconciliation that credibly supports the range typically adopted in macroeconomic simulations.

¹⁸See World Bank (2014), Table 4.8

Table 2.1: The Benchmark Economy

Parameter values	
Preference parameters	$\beta = 0.04, 0.06$ $\theta = 0.75$, $\gamma = -1.5$, $\eta = 1.75$
Production parameter	$\alpha = 0.36$
Productivity parameter	$A = 0.8$
Depreciation rate	$\delta = 0.05$
World interest rate	$i^* = 0.06, 0.04$
Premium on borrowing	$a = 0.15$
Weight on the premium	$\xi = 1$
Export function	$b = 2.0, c = 3.0$
Tariffs	$\tau = 0.10$

credit-output ratio of 0.53. The corresponding row of Part B reports the equilibrium for a debtor nation. This yields a capital-output ratio of around 3.27 and an equilibrium debt-output ratio of around 0.42. As one would expect, with the two economies being otherwise structurally identical, the debtor economy has less output and capital than does a similar credit economy. Table 2.3 reports the initial measures of wealth and income inequality, as measured by their respective coefficient of variation, where the initial wealth inequality is normalized to one.

While we do not attempt to calibrate to a specific economy or episode, we view these as providing plausible benchmarks designed to facilitate our understanding of the mechanisms in play as the economy evolves over time in response to a tariff reduction, the specification of which is as follows. Starting from the initial benchmark, with the tariff rate at 10%, we specify its elimination in two alternative ways. The first is immediate complete elimination. The second is where the elimination takes place gradually, at the known rate of 10% per year. In the latter case, the complete elimination of tariffs is achieved only asymptotically, although it is straightforward to impose a finite time horizon. The key point is that the moment the tariff is put in place, its *future* levels along the transitional path become fully anticipated and begin to influence behavior.

Table 2.2: Steady-state equilibrium responses to tariff reduction 10% to 0.

A. Creditor Country: $\beta = 0.04, i^* = 0.06$									
	\tilde{Y}	\tilde{L}	\tilde{K}	\tilde{B}	\tilde{V}	\tilde{s}	\tilde{C}	\tilde{x}	\tilde{y}
Benchmark case:									
$\alpha = 0.15, \theta = 0.75$									
Initial eq. ($\tau = 0.10$)	0.467	0.303	1.867	0.723	2.114	0.341	0.392	0.294	0.261
Eliminate tariff ($\tau = 0$)	0.472	0.308	1.897	0.711	2.147	0.352	0.389	0.292	0.276
% Change	(+1.61)	(+1.61)	(+1.61)	(-1.62)	(+1.61)	(+3.28)	(-0.70)	(-0.70)	(+5.76)
More open in trade:									
$\alpha = 0.15, \theta = 0.50$									
Initial eq. ($\tau = 0.10$)	0.459	0.298	1.836	0.552	2.079	0.440	0.395	0.197	0.408
Eliminate tariff ($\tau = 0$)	0.474	0.308	1.897	0.554	2.147	0.452	0.389	0.195	0.431
% Change	(+3.29)	(+3.29)	(+3.29)	(+0.45)	(+3.29)	(+2.84)	(-1.40)	(-0.70)	(+5.47)
More open in finance:									
$\alpha = 0.03, \theta = 0.75$									
Initial eq. ($\tau = 0.10$)	0.436	0.283	1.742	4.051	2.892	0.284	0.404	0.303	0.323
Eliminate tariff ($\tau = 0$)	0.443	0.288	1.771	3.909	2.943	0.299	0.401	0.301	0.335
% Change	(+1.66)	(+1.66)	(+1.66)	(-3.52)	(+1.66)	(+5.67)	(-1.67)	(-0.67)	(+3.72)
B. Debtor Country: $\beta = 0.06, i^* = 0.04$									
	\tilde{Y}	\tilde{L}	\tilde{K}	\tilde{B}	\tilde{V}	\tilde{s}	\tilde{C}	\tilde{x}	\tilde{y}
Benchmark case:									
$\alpha = 0.15, \theta = 0.75$									
Initial eq. ($\tau = 0.10$)	0.421	0.306	1.377	0.511	1.195	0.356	0.349	0.262	0.223
Eliminate tariff ($\tau = 0$)	0.428	0.311	1.399	0.505	1.214	0.366	0.346	0.260	0.237
% Change	(+1.60)	(+1.60)	(+1.60)	(-1.06)	(+1.60)	(+2.69)	(-0.71)	(-0.71)	(+6.36)
More open in trade:									
$\alpha = 0.15, \theta = 0.50$									
Initial eq. ($\tau = 0.10$)	0.414	0.301	1.332	0.406	1.176	0.440	0.351	0.176	0.363
Eliminate tariff ($\tau = 0$)	0.428	0.311	1.399	0.409	1.214	0.452	0.346	0.173	0.383
% Change	(+3.28)	(+3.28)	(+3.28)	(+0.63)	(+3.28)	(+2.64)	(-1.41)	(-1.41)	(+5.66)
More open in finance:									
$\alpha = 0.03, \theta = 0.75$									
Initial eq. ($\tau = 0.10$)	0.462	0.336	1.511	2.445	0.514	0.408	0.334	0.250	0.186
Eliminate tariff ($\tau = 0$)	0.469	0.341	1.534	2.437	0.552	0.416	0.331	0.243	0.199
% Change	(+1.54)	(+1.54)	(+1.54)	(-0.36)	(+1.54)	(+1.88)	(-0.78)	(-0.76)	(+7.15)

2.5 Elimination of tariffs

We now consider the elimination of an initial 10% tariff, contrasting the dynamics in the cases of instantaneous versus gradual reduction.

Table 2.3: Steady-state equilibrium responses to tariff reduction from 10% to 0.

A. Creditor Country: $\beta = 0.04, i^* = 0.06$				
	$\tilde{\sigma}_v$		$\tilde{\sigma}_q$	
	Discrete $\Delta\tau$	Gradual $\Delta\tau$	Discrete $\Delta\tau$	Gradual $\Delta\tau$
Benchmark case: $a = 0.15, \theta = 0.75$				
Initial equilibrium ($\tau = 0.10$)	1.000	1.000	0.0784	0.0784
Eliminate tariff ($\tau = 0$)	0.997	0.987	0.0800	0.0792
% Change	(-0.26)	(-1.3)	(+2.06)	(+1.02)
More open in trade: $a = 0.15, \theta = 0.50$				
Initial equilibrium ($\tau = 0.10$)	1.000	1.000	0.0765	0.0765
Eliminate tariff ($\tau = 0$)	0.993	0.973	0.0796	0.0780
% Change	(-0.74)	(-2.7)	(+3.99)	(+1.96)
More open in finance: $a = 0.03, \theta = 0.75$				
Initial equilibrium ($\tau = 0.10$)	1.000	1.000	0.104	0.104
Eliminate tariff ($\tau = 0$)	1.003	0.994	0.107	0.106
% Change	(+0.28)	(-0.60)	(+2.69)	(+1.92)
B. Debtor Country: $\beta = 0.06, i^* = 0.04$				
	$\tilde{\sigma}_v$		$\tilde{\sigma}_q$	
	Discrete $\Delta\tau$	Gradual $\Delta\tau$	Discrete $\Delta\tau$	Gradual $\Delta\tau$
Benchmark case: $a = 0.15, \theta = 0.75$				
Initial equilibrium ($\tau = 0.10$)	1.000	1.000	0.0747	0.0747
Eliminate tariff ($\tau = 0$)	0.996	0.985	0.0760	0.0753
% Change	(-0.63)	(-1.5)	(+1.68)	(+0.80)
More open in trade: $a = 0.15, \theta = 0.50$				
Initial equilibrium ($\tau = 0.10$)	1.000	1.000	0.0730	0.0730
Eliminate tariff ($\tau = 0$)	0.989	0.969	0.0757	0.0741
% Change	(-1.10)	(-3.10)	(+3.61)	(+1.51)
More open in finance: $a = 0.03, \theta = 0.75$				
Initial equilibrium ($\tau = 0.10$)	1.000	1.000	0.0336	0.0336
Eliminate tariff ($\tau = 0$)	0.969	0.978	0.0333	0.0336
% Change	(-3.06)	(-2.20)	(-0.80)	(0.00)

2.5.1 *Instantaneous elimination of tariffs*

We shall focus first on the benchmark parameterization $\theta = 0.75$, $a = 0.15$ presented in the first panel of Table 2.2.A, corresponding to the creditor economy. As noted previously, the long-run effects on the aggregate economy are the same whether the tariff is eliminated instantly or gradually over time. The simulations suggest that reducing the tariff from 10% to zero will cause long-run output, employment, capital, and wealth to all increase by 1.61%, while the international price of the imported good will increase by 3.28%. Overall consumption expenditure (inclusive of tariffs) will decline, as will the domestic price of the imported good, and the consumption to wealth ratio. All of these results are consistent with (2.21).

Much the same responses are observed for a debtor country. The only significant difference is that whereas the increase in the international price stemming from the reduced tariffs causes a creditor country to reduce its lending, debtor countries borrow less. In both cases these responses stem directly from the nature of the borrowing/lending function.

The dynamics are straightforward and are illustrated by the solid lines in figs. 2.1. On impact, the immediate elimination of the tariffs raises the international price of imported goods, s , by around 2.3%, leading to an immediate increase in exports (figs. 2.1a, 2.1b). While the increase in s is significant, it falls far short of the 10% reduction in tariffs and so the domestic price of the imported good declines, leading to an increase in imports (fig. 2.1c). This dominates the export response and overall the balance of trade declines (consistent with the traditional Marshall-Lerner condition). At the same time, the increase in s increases the lending country's relative share in the world bond market constraining its interest rate, reducing the capital account and thus the overall current account, causing its overall holdings of foreign bonds to decline (figs. 2.1d, 2.1e).

Figure 2.1: Creditor Nation ($i^* > \beta$). Elimination of tariff from 10%.

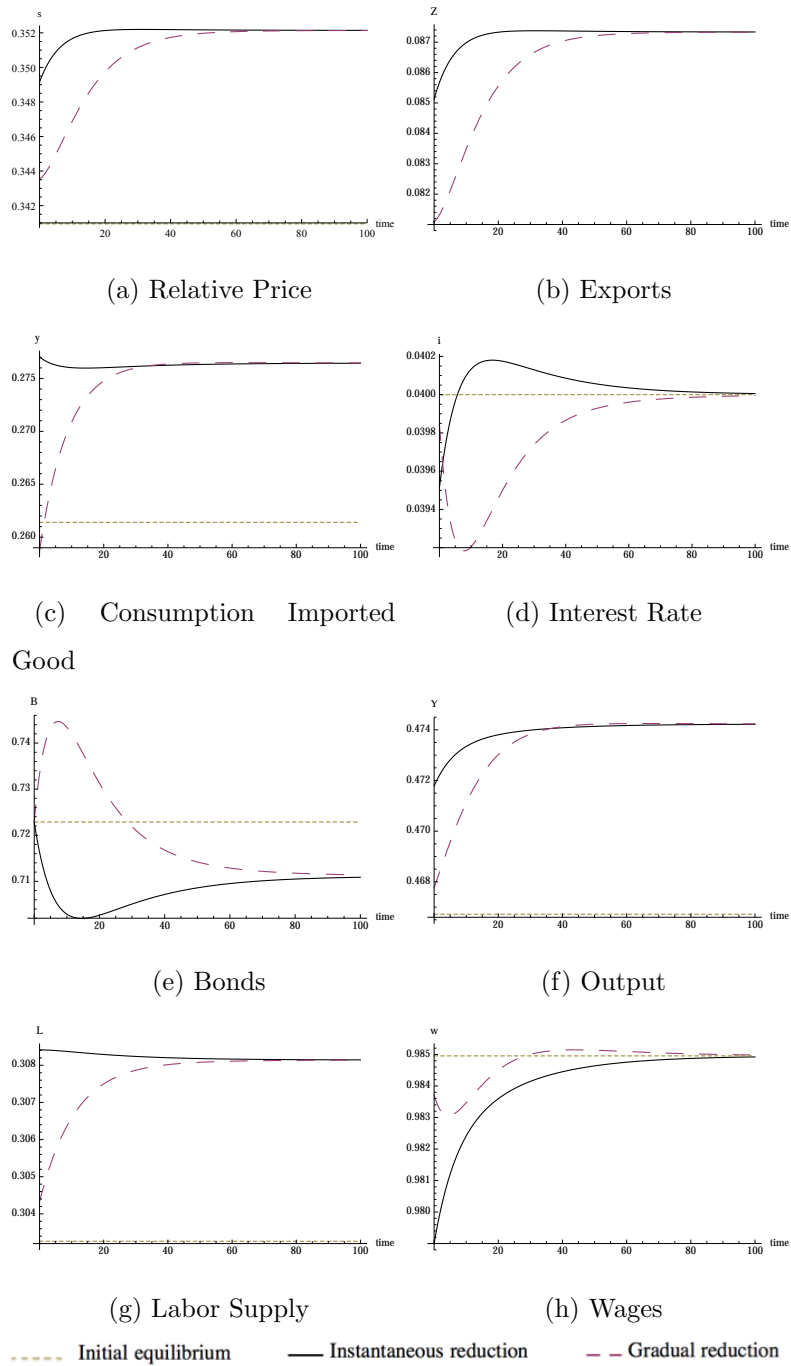
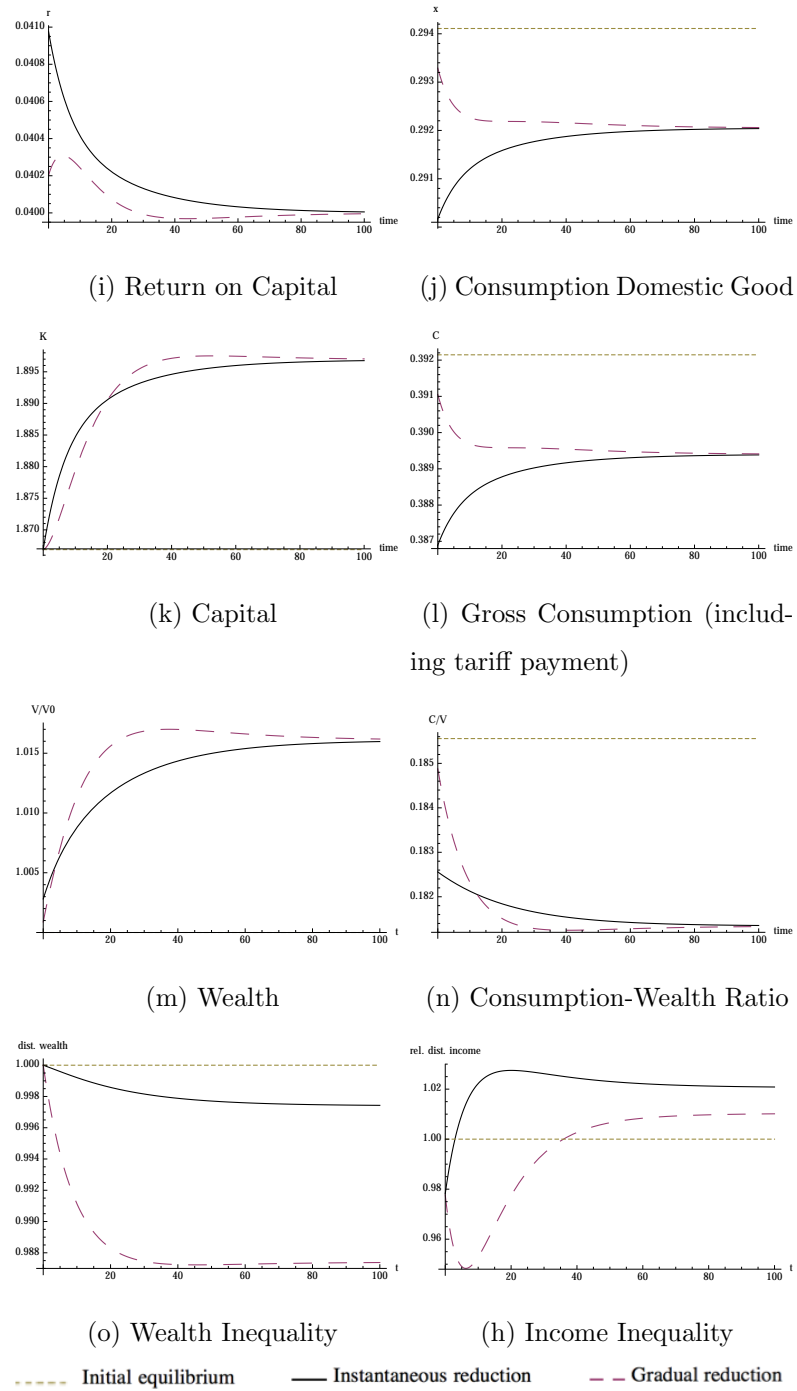

Figure 2.1: Creditor Nation ($i^* > \beta$).

Elimination of tariff from 10% (continuation).



Domestically, the increase in exports stimulates production, and output increases by a little over 1% (fig. 2.1f). With the capital stock fixed in the short run, this is met by an increase in labor supply which increases instantaneously from its initial equilibrium of 0.303 to in excess of its long-run response of 0.308 (fig. 2.1g). The increase in labor supply leads to a sharp reduction in wages accompanied by an increase in the return to capital (figs. 2.1h, 2.1i). The implied reduction in leisure reduces the marginal utility of domestic consumption so that x immediately drops by about 1.4% (fig. 2.1j). The increase in the return to capital stimulates investment so that the capital stock begins to increase (fig. 2.1k). Finally, while the reduction in tariffs reduces overall gross consumption expenditures, the increase in the relative price raises wealth (measured in terms of domestic output) and the consumption-wealth ratio rises (figs. 2.1l-2.1n).

The transitional dynamics following these initial responses are driven by the subsequent evolution of capital and foreign bonds. As capital is accumulated, wages begin to rise and the return to capital declines (figs. 2.1h, 2.1i). This causes firms to substitute capital for labor in production, so that employment of labor gradually declines, albeit slightly (fig. 2.1g), and output continues to expand (fig. 2.1f). The increasing leisure raises the marginal utility of domestic consumption so that x begins to increase (fig. 2.1j). With the tariff now removed the increase in x must be matched by the increase in sy in order for demand to be consistent with supply. How this is allocated between the imported consumption good and its price depends upon the openness of the economy, θ . For $\theta = 0.75$, the initial jump in $s(0)$ is relatively small, s increases at a faster rate than does x and y actually declines, but at a very slight rate.

As the capital stock increases, the initial decline in the interest rate is arrested and it gradually reverts to its original equilibrium rate $\beta = 0.04$. As a result, the decline in the current account is reversed and after about 15 years it becomes positive and foreign bonds are accumulated, partially regaining their initial equilibrium levels. With the declining marginal productivity of capital, the rate of capital accumulation slows down and the aggregate economy converges to its new

steady-state equilibrium.

Turning now to the inequality measures, the aggregate evolution we have been describing are reflected in the dynamics of wealth inequality and income inequality, which as noted previously are dependent on the time path followed by the tariff reduction (figs. 2.1o, 2.1p). With tariffs being removed immediately, (2.30) implies that the dynamics of wealth inequality is driven entirely by the time path of labor supply during the transition. And with the labor supply declining gradually during the transition (following its initial increase) (2.30) further implies that wealth inequality will decline gradually, albeit it slightly by 0.26%. Income inequality, in contrast, responds non-monotonically. In the short-run the sharp increase in labor reduces the share of income due to capital and together with the decline in wealth inequality, income inequality declines by about 2%. However, the rate of capital accumulation rapidly eradicates this and in the long run the decline in the consumption-wealth ratio declines sufficiently to suggest a long-run increase in income inequality of around 2%.

The same patterns generally characterize the dynamic adjustments of a debtor economy, with some differences. First, the imperfection in the capital market is reflected by a short-run increase in its borrowing rate, rather than a decline in its lending rate. Second, with the transitional decline in the labor supply more pronounced, the long-run decline in wealth inequality is around 0.63%. Also, on impact income inequality increases by around 2% rather than declines, this being a reflection of the lower initial degree of income inequality in the debtor economy. Third, the “hump” characteristic of the transitional path of income inequality is more pronounced, so that in the long-run tariff reduction generates less income inequality than it does in the creditor economy.

2.5.2 Gradual elimination of tariffs

While the long-run responses of the aggregate variables are unaffected by the time path followed by the tariff reduction, the transitional paths, however, are quite different, leading to substantial differences in the distributions of wealth

and income, both during the adjustment and in steady state. In some cases the short-run responses are in the opposite direction from those followed when the tariff elimination is completed instantaneously. The key to understanding the difference is the fact that in contrast to when the full change takes effect immediately at time $t = 0$, tariffs at time 0, $\tau(0)$ remain unchanged; instead, $\dot{\tau}(0)$ begins to decline and agents now fully anticipate the subsequent future reduction in the tariffs.

The dynamic time paths are now illustrated by the dashed lines in fig. 2.1, and again we shall focus on the creditor nation. The anticipation of the eventual elimination of the tariff raises the international price of the imported good, s , though not by as much as when the tariff is eliminated immediately. The relative price now increases by only 0.7%, leading to a much smaller increase in exports (figs. 2.1a, 2.1b). With the tariff remaining unchanged, the domestic price of the imported good immediately increases, leading to an initial decline in imports (fig. 2.1c) leading to an increase, rather than a decrease in the balance of trade. With the small change in the relative price, the impact on the interest rate is small and the country runs a current account surplus, increasing, rather than decreasing, its holdings of foreign bonds; (fig. 2.1e).

The small increase in exports leads to a modest increase in domestic production, which is met by a small increase in labor supply by about 0.5 percentage points from its initial equilibrium of 0.303 to something over 0.304 (fig. 2.1g). This in turn leads to a small reduction in the wage rate, a small increase in the return to capital (figs. 2.1h, 2.1i), a small decline in leisure leading to small decline in the consumption of the domestic good (fig. 2.1j). Capital also begins to rise, but at a slower rate.

In the early stages of the transition, while tariffs are slow to decline, this pattern will generally continue. However, over time, as the tariff reduction continues, it begins to play a more dominant role and some of these trends begin to be reversed. Thus, for example, imports begin to increase and the rising international price, s , increases exports, stimulates the domestic economy, increasing output, employment, and capital accumulation. As a result of all these responses the de-

cline in the real wage rate is reversed and the current account surplus is eventually reversed.

The increase in labor supply during the transition tends to increase wealth inequality. However, this is now accompanied by a declining tariff rate, which has precisely the opposite effect. Moreover, since the reduction in the tariff during the transition is 10 percentage points, while the increase in labor supply is of the order of 1%, this effect dominates and wealth inequality declines by 1.3%, substantially more than when the tariff is eliminated immediately.

The rapid decline in wealth inequality coupled with the initial decline in the income share of capital leads to a short-run decline in income inequality, which is eventually reversed over time. This is because, while the reduction in wealth inequality levels off, with the gradual tariff reduction, the impact of the reduction in the consumption-wealth ratio takes time to build up, but eventually dominates. However, the larger long-run decline in wealth inequality moderates the long-run increase in income inequality which is now reduced to 1.02%, approximately half that when the tariff is eliminated instantaneously.

2.5.3 Increase in openness

The second and third panels in Tables 2.2 and 2.3 vary the degree of openness of the economy, focusing in turn on the case where the economy is more open to trade ($\theta = 0.5$) and where the economy is more open in the financial market ($a = 0.03$).

As θ declines from 0.75 to 0.50 and the economy becomes more open in trade the elimination of the tariffs has a more expansionary effect, and output and employment increase by 3.29%. The qualitative responses remain largely as illustrated in fig. 2.1, both for the creditor and debtor economies. The larger adjustment in labor supply along the transition means that wealth inequality declines more, but the larger reduction in the consumption to wealth ratio means a larger increase in income inequality.

Figure 2.2: Debtor Nation ($\beta > i^*$). Elimination of tariff from 10%.

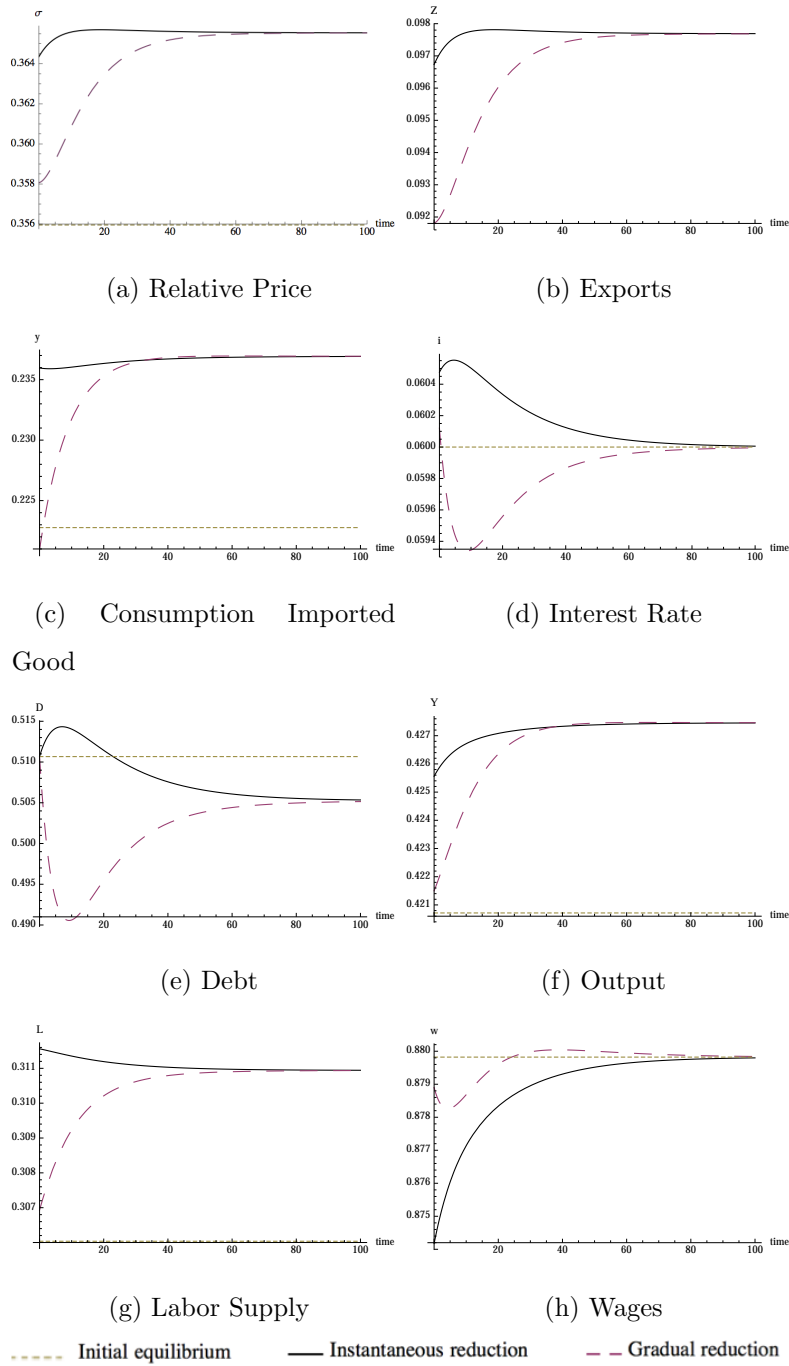
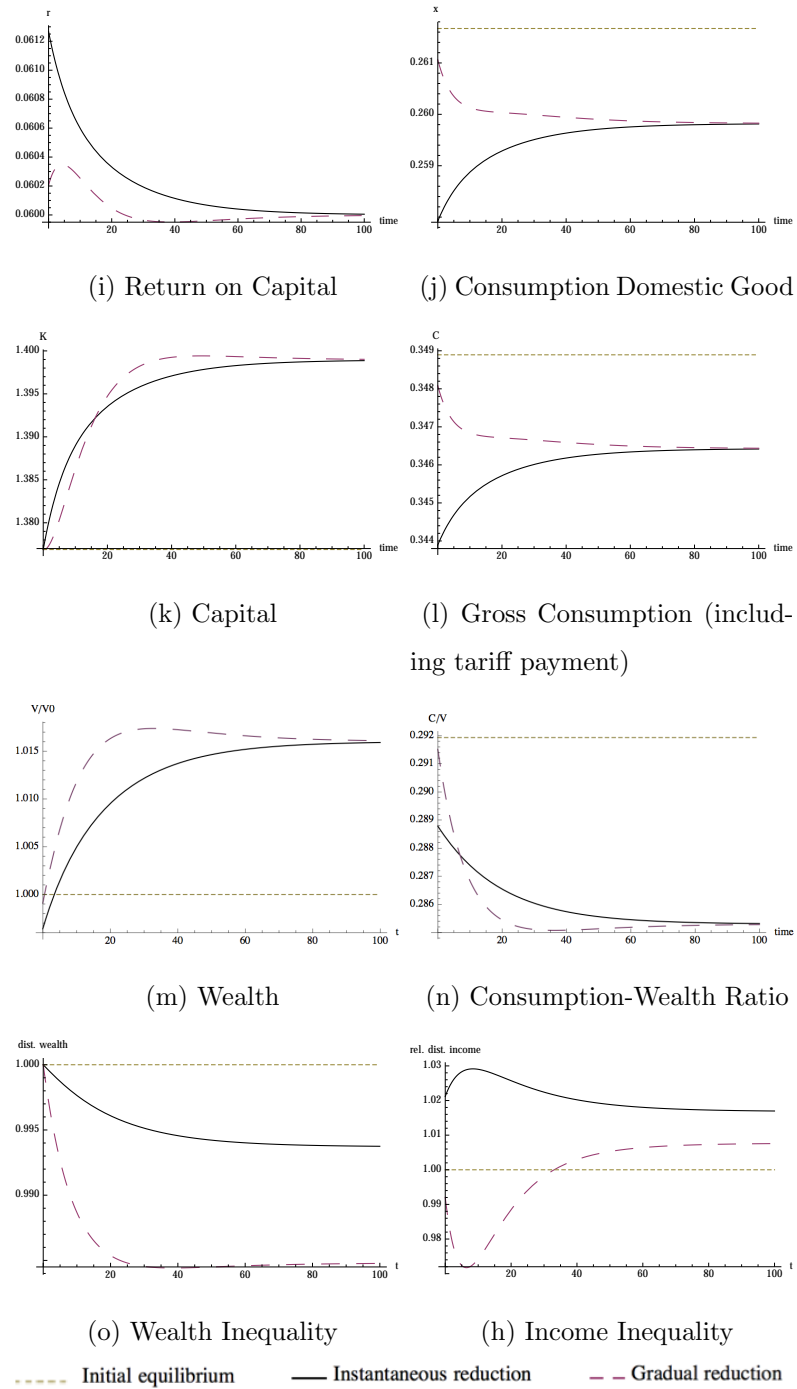

Figure 2.2: Debtor Nation ($\beta > i^*$).

Elimination of tariff from 10% (continuation).



As a decreases from 0.15 to 0.03 and the economy becomes more open in the financial sector, more qualitative differences emerge. The lending economy lends more and has higher consumption of both domestic and imported goods. More of its consumption is financed by its wealth, and output and employment are lower than in the benchmark economy. In this case the immediate elimination of tariffs is associated with a transitional path of increasing labor supply, causing wealth inequality to increase over time and to contribute toward the overall increase in income inequality that occurs.

The responses of a debtor economy summarized in Panel B are generally similar, both qualitatively and quantitatively. The main difference arises in the case when borrowing costs decline, in which case the elimination of the tariff has less impact on its debt reduction. With immediate tariff elimination wealth inequality actually declines to a sufficient degree that it dominates the impact of the decline in the consumption-wealth ratio and overall income inequality is reduced. In short, whereas in most cases a tariff reduction leads to a decline in wealth inequality accompanied by an increase in income equality, if the economy has relatively free access to the world financial market, both wealth and income inequality increase for a creditor economy and both decline for a debtor.

2.6 Conclusions

It is widely accepted that the recent increase in trade liberalization has had substantial distributional consequences, although the direction of the relationship and the mechanism driving it has been open to debate. In this paper we have analyzed the impact of tariff reductions on the dynamics of wealth and income inequality in a growing economy in which agents accumulate both physical capital and international bonds. Our study, which comprises a combination of formal analysis, supplemented with numerical simulations, suggests that in the long run the tariff reduction will be expansionary and be associated with both a reduction in wealth inequality but an increase in income inequality. Moreover, for plausible parameterization of the model our numerical simulations seem to be generally consistent

with empirical evidence.

One of the key characteristics of our analysis is the importance of the speed with which any change in tariff policy is implemented. Thus we find that reducing tariffs gradually will likely lead to a decrease in income inequality during the transition and a substantially mitigated long-run increase. However, this will be associated with a slower increase in output, particularly in the early stages of the transition. This implies a short-run tradeoff between the increase in activity and inequality that a policymaker implementing a tariff reduction policy will need to take into account in determining how rapidly such a policy should be introduced.

Chapter 3

TARIFF REDUCTION AND INCOME INEQUALITY: SOME EMPIRICAL EVIDENCE

The impact of tariffs on the aggregate economy has been widely studied, using a variety of analytical frameworks. The earliest study by [Mundell \(1961\)](#) and its extensions were purely static, employing some variant of the Mundell-Fleming model; see e.g. [Boyer \(1977\)](#), [Chan \(1978\)](#), and [Krugman \(1982\)](#). The general conclusion to emerge from this approach was that under flexible exchange rates, tariffs are contractionary, the key mechanism generating this being the Laursen-Metzler effect. [Eichengreen \(1981\)](#), provided the initial analysis of tariffs in a dynamic framework, using a currency substitution model to emphasize the intertemporal tradeoffs imposed by a tariff. He showed that while the protection provided by a tariff may be expansionary in the short run, over time the increase in savings and current account surplus causes a gradual reversal, so that in the long run the tariff will be contractionary.

Subsequent studies of tariffs have adopted a macrodynamic model based on intertemporal optimization. [Sen and Turnovsky \(1989\)](#) develop a one sector growth model of a small open economy and show how a tariff is contractionary both in the short run and in steady state. [Gardner and Kimbrough \(1989\)](#) and [Engel and Kletzer \(1990\)](#) employ a similar framework to analyze the impact of tariffs on savings and the trade balance. More recently, [Fender and Yip \(2000\)](#), and [Hwang and Turnovsky \(2013\)](#) analyze the effects of tariffs in the two-country new open economy model, developed by [Obstfeld and Rogoff \(1995\)](#) and [Obstfeld and Rogoff \(2000\)](#). All of this literature assumes homogeneous agents, and hence cannot address the potential distributional consequences of tariff policy.

The last three decades have been a period of dramatic trade liberalization. This has primarily taken the form of a steady reduction in tariffs, accompanied

by declining non-tariff barriers, particularly by developing economies. These developments have been associated with an increase in inequality, as [Goldberg and Pavcnik \(2007\)](#) have documented in detail. As these authors have also discussed, due in large part to data limitations, empirical studies have been restricted almost entirely to wage inequality, focusing particularly on the rising wage differential associated with the skill premium. Clearly the distributional consequences of trade liberalization are important, not only for the distribution of labor income, but also for broader definitions of income as well.

In a recent paper [Rojas-Vallejos and Turnovsky \(2015\)](#) address the effects of tariff reduction on both the aggregate performance of the economy and broader measures of income inequality, which include income from labor, capital and traded bonds. The framework they employ is the neoclassical growth model developed by [Sen and Turnovsky \(1989\)](#), in which heterogeneity across agents is introduced via initial endowments of physical capital as well as internationally traded bonds.¹ The Rojas-Vallejos-Turnovsky paper develops a theoretical framework for establishing the impact of tariffs on the aggregate-distributional tradeoffs, which is then supplemented with extensive numerical simulations. We use that framework to provide the basis for undertaking an empirical investigation of these tradeoffs, and for assessing the significance of tariff reduction for the observed increase in income inequality.

[Rojas-Vallejos and Turnovsky \(2015\)](#) establish two testable hypotheses pertaining to the relationship between tariffs and income distribution: (i) A reduction (increase) in the tariff rate leads to an increase (decrease) in income inequality, and (ii) the more rapidly the decrease (increase) in the tariff occurs, the larger the increase (decrease) in income inequality, both in the short and long run.² Being a direct generalization of the [Sen and Turnovsky \(1989\)](#) model, their model also

¹Heterogeneity is critical in studying inequality. While there are many sources of heterogeneity we focus on initial wealth endowments as most critical; see [Piketty \(2011\)](#).

²As we will discuss later in summarizing their model, [Rojas-Vallejos and Turnovsky \(2015\)](#) also establish a theoretical result describing the impact of tariffs on wealth inequality. While the evolution of wealth inequality is a key driving force behind the evolution of income inequality, paucity of wealth inequality data prevent us from examining this relationship.

implies that the reduction of tariffs is expansionary.

This paper tests these three hypotheses empirically. We find compelling support for the claim that tariff reduction increases income inequality in the short-run, but less conclusive evidence for the long-run effects. We also find solid support for the relationship between the speed of tariff adjustment and the response of inequality. However, this finding must be considered with caution, due to the limitations that the available data, despite their broad coverage, impose on the empirical methodology applied. Finally, the expansionary effect of tariff reduction is also strongly confirmed.

The main mechanism driving these responses is that a reduction in tariffs decreases the international price of exports, hence stimulating domestic production. This increase in output is initially obtained by an increase in labor supply that deteriorates wages and improves the rent on capital. The cumulative effect of these changes propels the underlying evolution of inequality.

One further issue is the following. To render the formal analysis tractable, [Rojas-Vallejos and Turnovsky \(2015\)](#) assume that the underlying utility function is homogeneous, thereby enabling them to exploit [Gorman \(1953\)](#) aggregation. As a result, the macroeconomic equilibrium is independent of any distributional characteristics.³ This implies that if one includes income inequality as a regressor in determining aggregate output, it should turn out to be statistically insignificant. In fact, when included it turns out to be significant instead, a finding that can be viewed as rejecting the underlying homogeneity restriction.

On the other hand, there is a substantial literature testing the hypothesis that inequality affects growth (output). Several studies obtain a negative relationship; see e.g. [Alesina and Rodrik \(1994\)](#), [Persson and Tabellini \(1994\)](#), and [Perotti \(1996\)](#). Others obtain a positive or more ambiguous relationship; see e.g. [Barro \(2000\)](#), [Forbes \(2000\)](#), and [Li and Zou \(1998\)](#). The fact that we obtain a negative relationship when we perform a cross-sectional analysis (as do Alesina and Rodrik)

³For this reason, [Caselli and Ventura \(2000\)](#) call this a “representative consumer theory of distribution”.

and a positive relationship when we use the panel structure of the data introducing fixed effects (as does Forbes) suggests that one reason for the contrasting results characterizing the literature may be due to statistical biases, as well as differences in underlying economic factors, data quality, coverage and comparability.⁴

The mechanism expositied in the [Rojas-Vallejos and Turnovsky \(2015\)](#) model is just one channel describing the relationship between trade liberalization and income distribution. The traditional Heckscher-Ohlin trade model provides an alternative framework. In this case the impact of trade liberalization depends upon factors such as the relative skill intensity of imports versus exports, the elasticity of labor supply, and the substitutability between capital and labor in production. Given the differences in sectoral production structures between developed and developing economies, the Heckscher-Ohlin model suggests that a tariff reduction will likely reduce inequality in an advanced economy, but increase it in a developing economy; see [Jaumotte et al. \(2013\)](#).

Thus, with competing narratives, predicting the evolution of inequality due to a change in the tariff policy is challenging since the relationship may incorporate many elements. In addition to differences pertaining to the production and trade characteristics, there are sociological and political elements particular to each economy. These country-specific characteristics may respond in diverse ways to similar types of economic shock. Empirical evidence so far has been somewhat inconclusive as to whether trade openness alleviates or worsens income inequality. This paper provides a channel that explains a fraction of the observed variation in the data.

Other studies attempting a similar objective include [Milanovic and Squire \(2005\)](#), who find that tariff reduction is associated with more wage inequality in poorer countries, while the reverse applies in richer countries. This contradicts the Heckscher-Ohlin prediction, noted above. In this paper, we are interested in

⁴The explanations for the negative relationship include: the political economy consequences of inequality, the negative impact of inequality on education, capital market imperfections and credit constraints. Explanations for the positive relationship include: the relative savings propensities of rich versus poor, investment indivisibilities, and incentives.

performing causal inference on within-country inequality, and therefore we focus on the within dimension of our panel dataset. Another empirical study that seems to refute the Heckscher-Ohlin prediction is [Savvides \(1998\)](#) who finds that among less developed countries, more open economies experienced increased income inequality during the late 1980s, while no effects are observed in advanced nations.

Perhaps the study closest to ours is [Jaumotte et al. \(2013\)](#). They present evidence supporting the idea that a reduction in tariffs would decrease inequality. While their study is rigorous, they combine data on Gini coefficients obtained from income and expenditure surveys. In addition, they do not consider the possible endogeneity of the tariff rate in their econometric analysis, although they allow for other types of endogeneity. All this might bias the impact of the tariff, which is our focus.⁵ Furthermore, the Rojas-Vallejos-Turnovsky model shows that consumption inequality moves together with wealth inequality. The prediction in the model that tariff reduction decreases wealth inequality, and hence consumption inequality, suggests that combining both types of Gini may induce an attenuation of the impact or even reverse the signs depending upon the frequency of these observations in the sample.

Most of the literature assumes (explicitly or implicitly) that countries respond uniformly to trade liberalization and determine in effect the average response. In reality, the responses may vary across countries, as in the simulations of [Rojas-Vallejos and Turnovsky \(2015\)](#), where they find somewhat diverse responses between creditor and debtor countries to tariff reductions. [Lim and McNelis \(2014\)](#) address the important issue of heterogeneous responses and find that as trade openness increases, income inequality increases for low- and lower-middle-income countries, but declines for upper-middle-income countries. To perform this analysis, they aggregate over various trade and financial indices and divide the sample into different income groups.

Unfortunately, this approach to investigating heterogeneity is unavailable to

⁵[Katsimi and Moutos \(2010\)](#) provide evidence that supports channels of simultaneity between inequality and tariff rates. Hence, the potential endogeneity for the tariff should be addressed.

us, since the aggregation obscures the role of tariffs, which is the key element of our analysis. This raises two potential problems. First, without aggregation we may have a very unbalanced panel, and second the number of observations may be small. Both issues occur in our dataset. Moreover, we need to use clustered standard errors, which reduces the effective number of observations even further.⁶ To make the best use of all available information, we adopt an alternative procedure to estimate these heterogeneous effects of tariffs on income inequality and apply a panel smooth transition regression (PSTR) model.⁷ In order to apply this technique, we need to create a balanced panel, which we do by taking averages of each variable over a 5-year period. Using the PSTR, we obtain similar qualitative results to [Lim and McNelis \(2014\)](#), but specifically with respect to tariffs. However, due to data limitations we are unable to address the endogeneity of tariffs in the PSTR model.

The remainder of the paper is structured as follows. In the next section, we present some background characteristics of trade and inequality. Section 3 summarizes the underlying model and discusses the impact of decreasing tariffs for economic activity and inequality. Section 4 describes the data and empirical methodology. Section 5 presents the results and discussion, and Section 5 concludes. Other details are in Appendix B.

3.1 Tariffs and Inequality: Stylized Facts

Figure 3.1 illustrates some of the key characteristics relating to trade openness, tariffs, and income inequality as measured by the income Gini coefficient. In Fig. 3.1.a we see that the average trade openness for our sample of countries has grown from around 20% in the early 1980s to above 100% before the Great

⁶To analyze the data correctly, correlations between observations from the same country need to be taken into account. If not, the standard errors of the estimates can be substantially downwardly biased, leading to potentially invalid inferences. The intra-class correlation (ICC) in our case for the Gini data is 0.92, while for the tariff rate is 0.44. This is a high ICC considering that a number above 0.02 may cause some problems.

⁷See [González et al. \(2005\)](#). In Section 3.3.2 below, we provide a brief description of this method.

Recession, indicating that trade integration more than quadrupled during this period of time.⁸ Fig. 3.1.b shows that tariff rates fell from about 20% in 1984 to slightly more than 5% in 2010 with an average of approximately 10% for the whole period.⁹ This shows a sharp decline in tariff rates, a trend that is observed in different degrees in our sample. Of course, these simple plots do not imply any causal link between the variables, but the correlation is clear and other empirical and theoretical studies support this trend for tariffs; see [Bohara et al. \(2004\)](#) and [Wacziarg and Welch \(2008\)](#). Clearly, more international trade, on average is better for nations, but some will win more than others, and eventually some will lose. Hence, trade globalization have distributional consequences, even if the overall income for a given economy increases.

Fig. 3.1.c is constructed using data on income Gini coefficients from the comprehensive database developed by [Milanovic \(2014\)](#). This figure indicates how income inequality within countries on average has steadily increased throughout most nations in the world since the late 1980s. At the same time, the level of overall income has increased, suggesting that most people have higher living standards than they did three decades ago, as discussed in [Sala-i-Martin \(2006\)](#). However, the benefits of this income growth have not been shared uniformly within societies. Hence, within-country inequality has worsened in most countries around the world as described in [Jaumotte et al. \(2013\)](#).

As we have noted, one of the theoretical results obtained is that the speed with which tariffs are altered - whether increased or decreased - affects the size of the impact of the tariff change on income inequality. Thus, tariffs may exhibit a heterogeneous relationship with inequality. Fig. 3.1.d illustrates a few examples of developing countries that did indeed reduce their tariffs at much faster rates than did advanced economies, confirming the empirical relevance of this theoretical

⁸Trade openness is defined as the ratio of exports and imports of goods and services to GDP. These data are from the World Development Indicators (WDI) database.

⁹Applied tariff rate data are from the Data on Trade and Import Barriers database at the World Bank compiled by Francis K. T. Ng, consisting of 170 countries for the period 1981 to 2010.

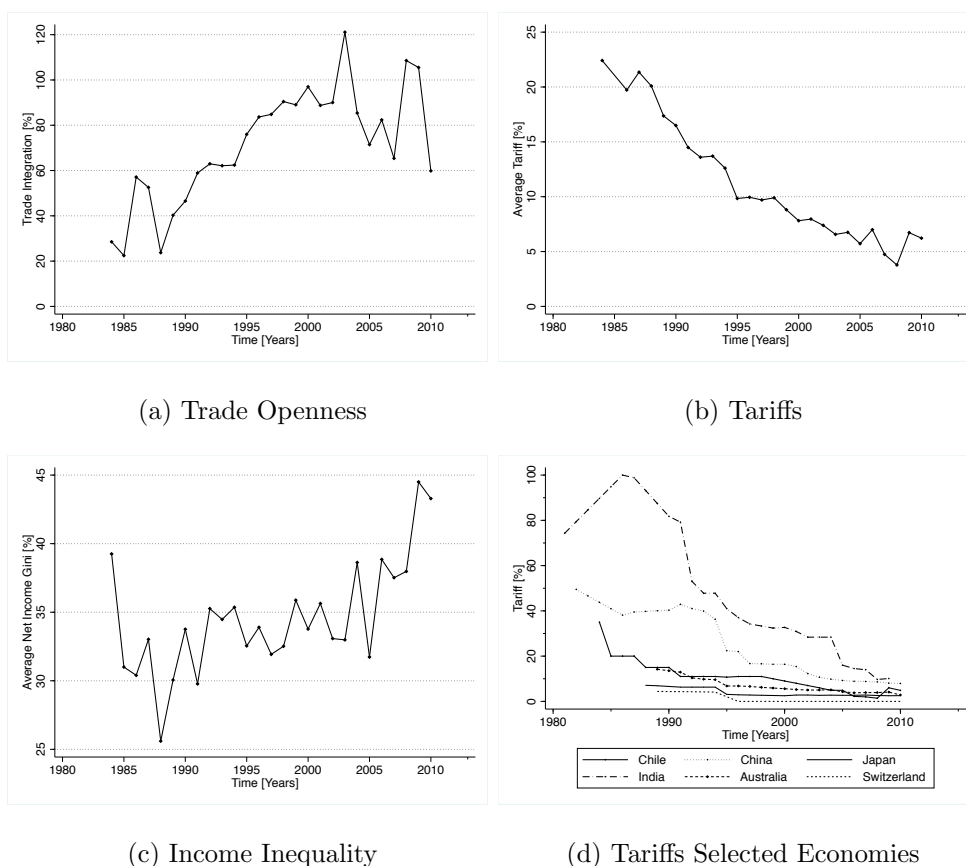

Figure 3.1: Stylized Facts

result. This reflects the following fact. Advanced economies, being much more integrated with each other than developing nations, already had low tariff rates in place in the early 1980s. Therefore, even though developed countries also reduced their tariffs, their overall reduction was much smaller than what is observed in emerging countries such as Chile or China for example. Due to the paucity of data, the unbalanced structure of the panel, and the non-monotonic reduction of tariffs, we are not able to directly test the impact of the speed of the tariff adjustment on inequality. Therefore, we use the tariff level as a proxy for the speed of tariff adjustment. In our sample, developing countries tend to start out with much higher tariff rates than developed countries, but by the end of the period, there is convergence to low tariff rates. Thus, we use a PSTR model to

investigate heterogeneous or nonlinear impact of tariffs on inequality.

3.2 The Model

As already noted, the analytical model underlying our empirical study is a heterogeneous agent extension of [Sen and Turnovsky \(1989\)](#), and is developed in detail in [Rojas-Vallejos and Turnovsky \(2015\)](#). Here we simply summarize its main structure and relevant implications.

There is a single representative firm that produces a domestic good using a standard constant returns to scale neoclassical production function,

$$Y = F(K, L) \quad F_K > 0, F_L > 0, F_{KK} < 0, F_{LL} < 0, F_{KL} > 0 \quad (3.1)$$

where K , L and Y denote the economy-wide average stock of capital, labor supply and output, respectively. Markets are competitive, so factors are paid their respective marginal products,

$$r(K, L) = F_K(K, L) - \delta \quad r_K = F_{KK} < 0, r_L = F_{KL} > 0 \quad (3.2a)$$

$$w(K, L) = F_L(K, L) \quad w_K = F_{LK} > 0, w_L = F_{LL} < 0 \quad (3.2b)$$

where δ is the depreciation rate of capital.

The economy is populated by a mass one of infinitely-lived individuals, indexed by j , who are identical in all respects except for their initial endowments of capital, $K_{j,0}$, and of an internationally traded bond, $B_{j,0}$. Since we are interested in distribution and inequality, we shall focus on individual j 's relative holdings of capital and bonds, $k_j(t) \equiv K_j(t)/K(t)$, $b_j(t) \equiv B_j(t)/B(t)$ where $B(t)$ denotes the economy-wide average stock of bonds. Initial relative endowments, $k_{j,0}, b_{j,0}$ have mean one and relative standard deviations, $\sigma_{k,0}, \sigma_{b,0}$ across agents.¹⁰ Each agent is also endowed with one unit of time that he can allocate to labor, L_j or enjoy as leisure, l_j , so that $l_j(t) + L_j(t) = 1$. With a continuum of agents, the

¹⁰These initial endowments can be perfectly arbitrary and therefore consistent with any required non-negativity constraints. As will become apparent in the course of the analysis, the form of the distribution of the initial endowments will be reflected in the evolving distributions of wealth and income.

economy-wide average supply of labor is $L = \int_0^1 L_j dj$ and other aggregates are defined analogously.

Each individual j has lifetime utility that depends upon the following isoelastic function of the domestic consumption good, x_j , the imported consumption good, y_j , and leisure

$$U_j = \int_0^\infty \frac{1}{\gamma} (x_j(t)^\theta y_j(t)^{(1-\theta)} l_j(t)^\eta)^\gamma e^{-\beta t} dt$$

$$0 \leq \theta \leq 1, 0 < \eta, -\infty < \gamma \leq 1, \theta\gamma < 1, \eta\gamma < 1 \quad (3.3)$$

where $1/(1-\gamma)$ is the agent's intertemporal elasticity of substitution, θ measures the relative importance of domestic versus imported consumption, and therefore parameterizes the degree of openness from the consumption standpoint. The exponent, η , parameterizes the relative importance of leisure and β is the subjective discount rate. The remaining restrictions in (3.3) ensure concavity of the utility function in the two consumption goods and leisure.

The agent chooses his rates of consumption, $x_j(t)$, $y_j(t)$, labor supply, L_j and rates of accumulation of capital, $K_j(t)$, and traded bonds, $B_j(t)$, so as to maximize (3.3), subject to his instantaneous budget constraint, expressed in terms of units of domestic output as numeraire

$$s(t)\dot{B}_j(t) + \dot{K}_j(t) = w(K, L)L_j(t) + r(K, L)K_j(t) + i\left(\frac{sB}{K}\right)s(t)B_j(t) - x_j(t) - (1 + \tau(t))s(t)y_j(t) + T_j(t) \quad (3.4)$$

given his initial endowments of capital and bonds, where $s(t)$ denotes the relative price of the foreign good in terms of the domestic good. $\tau(t)$ denotes the rate of the tariff at time t , generating tariff revenues that are fully rebated by the government to consumers as lump-sum transfers, T_j .¹¹

Given the homogeneity of the utility function and the assumption that each agent faces the same factor returns, the optimality conditions imply that each

¹¹A key element of the model is that although the economy has access to the international capital market, it faces frictions, in the form of increasing borrowing costs or decreasing lending costs. These depend upon the aggregate economy-wide debt to capital ratio which the individual agent takes as given.

individual, j , will choose the same growth rate for the two consumption goods and for leisure, in which case these will also equal the corresponding economy-wide growth rate.¹² Thus,

$$\frac{\dot{x}}{x} = \frac{\dot{x}_j}{x_j} = \frac{\dot{C}_j}{C_j} = \frac{\dot{C}}{C}; \quad \frac{\dot{y}}{y} = \frac{\dot{y}_j}{y_j}; \quad \frac{\dot{l}}{l} = \frac{\dot{l}_j}{l_j} \text{ for all } j \quad (3.5)$$

where $C_j = x_j + (1 + \tau)sy_j$ denotes the gross consumption expenditure of agent j , inclusive of the tariff. The fact that the consumption and leisure of all agents occur at a common growth rate facilitates aggregation, leading to a macroeconomic equilibrium in which aggregates are independent of their distribution across individuals. Under weak conditions, given the time path of the tariff rate, the aggregate dynamics are characterized by a stable saddlepath in terms of $K(t), B(t), s(t), L(t)$.

The key long-run relationships in the model are given by:

$$d\hat{Y} = d\hat{L} = d\hat{K} = d\hat{B}' = d\hat{V} = -\frac{(1-\theta)}{1+\tilde{\tau}} \left(\beta \frac{\tilde{V}}{\tilde{C}} + \frac{\eta\tilde{L}}{1-\tilde{L}} \left[1 + \frac{(1+\theta\tilde{\tau})}{(1+\tilde{\tau})\eta} \right] \right)^{-1} \frac{d\tilde{\tau}}{1+\tilde{\tau}} \equiv -\Theta \frac{d\tilde{\tau}}{1+\tilde{\tau}} < 0 \quad (3.6a)$$

$$d\hat{C} = \frac{\tilde{L}}{1-\tilde{L}} \Theta \frac{d\tilde{\tau}}{1+\tilde{\tau}} > 0 \quad (3.6b)$$

$$d\hat{C} - d\hat{V} = \Theta \frac{d\tilde{\tau}}{1+\tilde{\tau}} > 0 \quad (3.6c)$$

where tildes denote steady-state values. These expressions, combined with numerical simulations, can be summarized in the following testable hypothesis:

Hypothesis 3.1 *A tariff reduction has an expansionary effect on output, capital and wealth in both the short and long run.*

From the factor returns generated by the aggregate equilibrium, one can derive the evolution of wealth inequality and income inequality. Defining agent j 's wealth by $V_j = K_j + sB_j$, his relative wealth is $v_j = V_j/V$. [Rojas-Vallejos and Turnovsky \(2015\)](#) then show that the only bounded solution for the resulting differential equation determining individual j 's relative wealth is the forward-looking

¹²See [Rojas-Vallejos and Turnovsky \(2015\)](#) for details. Although agents choose common growth rates, their respective levels will be different and will reflect their wealth differentials.

solution,¹³

$$v_j(t) - 1 = \frac{\chi(t)}{\chi(0)} (v_j(0) - 1) \quad (3.7)$$

where for notational convenience

$$\chi(t) \equiv \left[1 + \frac{1}{\tilde{V}} \left(\frac{\tilde{F}_L}{1 - \tilde{L}} \right) \int_t^\infty (L(u) - \tilde{L}) e^{-\beta(u-t)} du + \frac{1}{\tilde{V}} \left(\frac{\tilde{s}\tilde{y}}{1 + \tilde{\tau}} \right) \int_t^\infty (\tau(u) - \tilde{\tau}) e^{-\beta(u-t)} du \right] \quad (3.8)$$

Given the linearity of equation (3.7) across agents, we see that the distribution of wealth, measured by the coefficient of variation, $\sigma_v(t)$, evolves in accordance with,

$$\sigma_v(t) = \frac{\chi(t)}{\chi(0)} \sigma_{v,0} \quad (3.9)$$

From (3.7) and (3.8) we see that the time path for wealth inequality, including its long-run response, depends upon (i) the expected future transitional time path of aggregate labor supply as it responds to the tariff, and (ii) the expected future time path followed by the change in the tariff itself. This enables us to state the following,

Hypothesis 3.2 *To the extent that labor supply is increasing (decreasing) during the transition it will lead to a permanent increase (decrease) in wealth inequality. To the extent that the tariff is reduced (increased) gradually it will lead to a permanent decrease (increase) in wealth inequality.*

The numerical simulations carried out by [Rojas-Vallejos and Turnovsky \(2015\)](#) indicate a tradeoff between these two influences on wealth inequality. If the tariff reduction is completed instantaneously, this generates a large initial increase in labor supply, causing it to overshoot on impact and to decline slightly during the subsequent transition, leading to a small decline in wealth inequality. If the tariff reduction is gradual, the initial response in labor supply is moderated, the transition involves an increasing labor supply accompanied by an increasing tariff,

¹³This may be associated with a jump in the agents initial wealth through the relative price, $s(0)$. This occurs when the ratio of their initial endowments of the two assets deviates from the economy-wide ratio, i.e. $K_{j,0}/B_{j,0} \neq K_0/B_0$

with the latter effect dominating, leading to a decline in wealth inequality which exceeds that when the tariff reduction is instantaneous.¹⁴

The analysis for income inequality is analogous. We define income for agent j as the sum of income from wealth, labor income, and the lump-sum transfer from the government, $Q_j = rV_j + wL_j + T_j$, with aggregate income being $Q = rV + wL + T$. Assuming that tariff revenues are rebated uniformly across agents, $T_j = T$, the relative income of agent j , $q_j = Q_j/Q$, is related to his relative wealth by,

$$q_j(t) - 1 = \varepsilon(t) \left[1 - \left(\frac{\eta}{1 + \eta} \right) \left(\frac{C(t)}{\tilde{C}} \right) \left(\frac{\beta \tilde{V}}{r(t)V(t)} \right) \frac{1}{\chi(t)} \right] (v_j(t) - 1) \quad (3.10)$$

where $\varepsilon(t) \equiv r(t)V(t)/[r(t)V(t) + w(t)L(t) + T(t)]$ denotes the share of income from wealth in total personal income.¹⁵ Because of the linearity of (3.10) across agents, we can express the relationship between relative income and relative wealth in terms of the corresponding standard deviations of their respective distributions, $\sigma_q(t)$, $\sigma_v(t)$ by

$$\sigma_q(t) = \varepsilon(t) \left[1 - \left(\frac{\eta}{1 + \eta} \right) \left(\frac{C(t)}{r(t)V(t)} \right) \left(\frac{\beta \tilde{V}}{\tilde{C}} \right) \frac{1}{\chi(t)} \right] \sigma_v(t) \quad (3.11)$$

Hence the time paths of two elements drive the evolution of income inequality. The first is the dynamics of wealth inequality, $\sigma_v(t)$, as determined by (3.9); the second is the dynamics of factor returns as they impact the share of income from net wealth, $\varepsilon(t)$, and the ratio of consumption to income from wealth.

Assuming that the economy starts out in an initial steady state, (3.11) reduces to

$$\tilde{\sigma}_{q,0} = \frac{1}{1 + \eta} \left(\frac{\beta \tilde{V}_0}{\beta \tilde{V}_0 + \tilde{w}_0 \tilde{L}_0 + \tilde{T}_0} \right) \tilde{\sigma}_{v,0} = \left(\frac{\beta}{1 + \eta} \right) \frac{\tilde{V}_0}{\tilde{C}_0} \tilde{\sigma}_{v,0} \quad (3.12)$$

and dividing (3.11) by (3.12) we derive the following expression for income inequality relative to the initial steady-state inequality,

$$\frac{\sigma_q(t)}{\tilde{\sigma}_{q,0}} = \varepsilon(t) \left[1 - \left(\frac{\eta}{1 + \eta} \right) \left(\frac{C(t)}{r(t)V(t)} \right) \left(\frac{\beta \tilde{V}}{\tilde{C}} \right) \frac{1}{\chi(t)} \right] \left(\frac{1 + \eta}{\beta} \right) \frac{\tilde{C}_0}{\tilde{V}_0} \frac{\sigma_v(t)}{\tilde{\sigma}_{v,0}} \quad (3.13)$$

¹⁴If both adjustments are completed instantaneously wealth inequality remains unchanged at its initial level.

¹⁵See [Rojas-Vallejos and Turnovsky \(2015\)](#) for details.

In steady state (3.13) simplifies to,¹⁶

$$\frac{\tilde{\sigma}_q(t)}{\tilde{\sigma}_{q,0}} = \left(\frac{\tilde{C}_0/\tilde{V}_0}{\tilde{C}/\tilde{V}} \right) \frac{\tilde{\sigma}_v}{\tilde{\sigma}_{v,0}} \quad (3.14)$$

so that long-run income inequality varies positively with long-run changes in wealth inequality and inversely with changes in the gross consumption-wealth ratio. By reducing the gross consumption-wealth ratio a tariff reduction will increase long-run income inequality. To the extent that it decreases (increases) long-run wealth inequality it will decrease (further increase) income inequality.

Thus, the overall dynamic response of income inequality incorporates both these elements. As the numerical simulations performed by [Rojas-Vallejos and Turnovsky \(2015\)](#) suggest, although wealth inequality is almost certain to decline, this effect tends to be dominated by the response of the consumption-wealth ratio, so that income inequality will likely rise in long run. The short-run effects of a tariff reduction are more ambiguous and depend upon the structure of the specific economy. Based on their numerical simulations, in the case of a debtor nation, a fast reduction of tariffs will induce an immediate increase in income inequality which is sustained over time. In the case of a creditor economy, income inequality initially declines, although this is rapidly reversed. Therefore, we may state:

Hypothesis 3.3 *In the long run, a tariff reduction increases income inequality. In the short run, a tariff reduction generates a sustained increase in income inequality in a debtor nation; in a creditor nation it generates a temporary reduction in income inequality, which is almost instantaneously reversed.*

The fact that a gradual reduction in the tariff leads to a larger decline in wealth inequality in conjunction with the previous theoretical implications suggests,

Hypothesis 3.4 *The more rapidly a decrease in the tariff is implemented in a debtor nation, the larger the increase in income inequality in both the short and*

¹⁶To obtain (3.14) we use the steady-state conditions $\tilde{r} = \beta, \tilde{\chi} = 1$.

*long run.*¹⁷ *In a creditor nation the more rapid the decrease, the briefer the short-run decline and the larger the long-run increase in income inequality.*

A detailed discussion of the economic intuition behind these theoretical results, and specifically of the contrast between the instantaneous and gradual reduction in the tariff is provided by [Rojas-Vallejos and Turnovsky \(2015\)](#).

3.2.1 Other factors impacting income inequality

The economy described above is a stylized one in which markets are highly competitive, and the only friction is in the international financial markets. Even though the framework underlying the model is a plausible one, the relationship between trade liberalization and inequality is much more complex than what has been explicated here. It is important to acknowledge that many other elements affect the distribution of income, and its response to economic policy and more general changes in the economic environment. These include institutional and political elements coupled with other redistributive policies implemented by governments and influenced by different interest groups, such as trade unions and business associations. [Albertus and Menaldo \(2016\)](#) refer to them as the governing elite, arguing that their role is crucial to the evolution of inequality. Two countries having similar economic characteristics, but differing in the nature of their governing elite are likely to have distinct policies and regulations. Therefore, for a similar economic shock, income inequality may respond very differently. Thus, disentangling the effect of a tariff reduction on income inequality and establishing causality is a challenging task since it needs to take account of these structural differences. This necessitates the use of panel data estimation, as discussed in the next section.

¹⁷In testing this hypothesis we shall focus primarily on a debtor nation since more than 80% of the panel is formed by such economies. In addition, the few creditor nations were debtor nations in several of the years of the period analyzed.

3.3 Empirical Analysis

In this section we present the data and discuss the econometric methodology to test some of the hypotheses presented in Section 3. Unfortunately, due to lack of data on wealth inequality, we are unable to analyze Hypothesis 3.2.¹⁸ Some studies (e.g. [Alesina and Rodrik \(1994\)](#)) have used Gini coefficients on land to serve as a proxy for wealth inequality. However, we do not view this measure as particularly appropriate in the present international context, where in addition to domestic capital the alternative source of wealth includes traded financial assets.

Hypothesis 3.3 is testable by using data on income Gini coefficients, which are available for many countries over time. While the data are limited and suffer from many missing values, they suffice to perform a fairly rigorous empirical evaluation. Because countries with a negative net financial assets position form the overwhelming majority of the sample, we shall tend to interpret our results from the standpoint of a debtor nation. Thus, we first estimate in a panel specification the contemporaneous or short-run effect of tariff rates on income inequality, and then do a cross-sectional analysis to determine its long-run effects. The empirical evidence supports the small, but significant, effect of tariffs on inequality in the short run, but its support is weaker for the long run.

Next, we test Hypothesis 3.4. We find compelling evidence for tariffs having a heterogeneous effect on inequality. Adopting a panel smooth transition regression (PSTR) model and using the tariff level as a proxy for the speed of adjustment we find that a decrease in the tariff will decrease income inequality if the current tariff is below a threshold level of around 6%, and raise inequality if the current tariff level exceeds this threshold. Nonetheless, the PSTR analysis is subject to criticism regarding endogeneity that is hard to address in this specific case due to the lack of degrees of freedom. In any case, as discussed by [Fouquau et al. \(2008\)](#) and [Duarte et al. \(2013\)](#), using a PSTR model limits the potential endogeneity. In

¹⁸There are almost no data on wealth inequality that can be used to make causal inference in our framework. The Luxembourg Wealth Study (LWS) Database consists of 12 countries with one or two observations for each.

fact, the average of our PSTR estimates are close to the estimates obtained using the static and dynamic panel methods.

Finally, we test the familiar proposition stated in Hypothesis 3.1, confirming that tariff reduction is expansionary. In addition, we test for the impact of income inequality on aggregate activity. While the underlying homogeneity assumptions suggest this should have no effect, we find that for our sample of countries, inequality does impact on output, although the direction of the impact is sensitive to the econometric specification technique employed.¹⁹

3.3.1 Data

We use income Gini coefficients obtained from actual surveys compiled in the database *All The Ginis* (ATG) organized by Milanovic (2014) and available from the World Bank.²⁰ We also use the Standardized World Income Inequality Database (SWIID) provided by Solt (2009) as a robustness check.²¹ We note that Solts dataset of Gini coefficients includes imputed values that he obtains using the data collected by the Luxembourg Income Study (LIS) as the standard. However, we prefer to rely more on the data coming from actual surveys. In addition to the income Gini coefficients, we use income share by quintiles from the World Income Inequality Database (WIID) available at the United Nations. Data on tariff rates come from the World Bank, as well as do many of the other macroeconomic variables specified in the regressions. Data on financial variables are obtained from Lane and Milesi-Ferretti (2007). Data on domestic financial development come from the Global Financial Development Database (GFDD), available at the World Bank. Data on education are obtained from Barro and Lee (2001) and

¹⁹External validity concerns are important in this respect because most of the literature on the relationship between growth and inequality provided different signs on this relationship depending upon methods or samples. This discrepancy in signs suggests that the effect must be highly heterogeneous rather than homogeneous which is the dominating assumption in most of the existing literature.

²⁰This dataset is updated and improved in quality, coverage and comparability relative to the Deininger and Squire (1997) dataset.

²¹The SWIID and Lane and Milesi-Ferretti datasets are updated to 2013.

Barro and Lee (2013). Data on Information and Communications Technologies (ICTs) are obtained from Jorgenson and Vu (2005) and Jorgenson and Vu (2007). The political system is summarized by the civil liberties index provided by the Freedom House Foundation.²²

After organizing all these variables, we obtain a panel dataset containing 73 countries extending over the period of time 1984-2010. Given the significant number of missing values, the number of observations containing tariff rates and income inequality is reduced to 557. If to this we add the missing values in other variables that we use as controls, we end up with an effective sample size of 37 countries and 334 observations. By removing the measure of inequality, the sample size may become as large as 166 countries with over 1000 observations (see Table 3.8). This illustrates the important problem of missing values in this type of study. We avoid interpolation because to do so imposes further restrictive assumptions. Thus, we follow an approach similar to Breen and García-Peñalosa (2005), Jaumotte et al. (2013), among others.²³ More details about the data and the countries in the sample are provided in Appendix B.

3.3.2 Methodology

To test the propositions we apply three different methodologies. To estimate the causal effect of tariffs on inequality we use static and dynamic panel models. To estimate the heterogeneous effect that tariff could have we use a panel smooth transition regression (PSTR) model. To look into the long-run effects we apply a cross-sectional regression model and a long-difference regression model.

Tariff and Inequality

To establish causality we use two identification strategies and two robustness checks. First, we use fixed effects in a panel context. This has the advantage

²²Similar indices from the Democracy Barometer were employed but results did not change substantially, just the sample size was reduced. Hence, we opt for the Freedom House indices that cover a longer period of time.

²³See also Bergh and Nilsson (2010), Milanovic and Squire (2005) and the references therein.

that it allows us to remove any omitted variable bias resulting from the correlation of unobserved time-invariant characteristics with the explanatory variable of interest, in our case tariffs. However, this technique does not adjust for unobserved characteristics that change over time. To deal with this aspect we include control variables that are known to be relevant for inequality, and may be correlated with tariffs. These are discussed in Section 3.3.3.

Regarding fixed effects, this technique presents some shortcomings in the particular case of income inequality, a rather stable variable over time. The problem is that fixed effects will remove any time-invariant heterogeneity, and if income inequality is highly stable over time, then the fixed-effects models will leave unexplained the most important variable in our analysis. This problem is important in our case since almost 85% of the variation in the income inequality data is due to variations between countries rather than within countries. In addition, other problems related to the within nature of panel estimation are attenuation bias and magnification error. This reduces the precision of the estimates.²⁴ Nevertheless, the main reason to adopt this approach is that to draw some causal statements, fixed effects are the appropriate technique; if they are not applied, then the estimates may be inconsistent. Country fixed effects are mainly used to control for cultural and institutional characteristics, while year fixed effects are used to control for common global shocks that impact most, if not all, the countries in our sample. The period of analysis extends from 1984 to 2010 using yearly data, during which there were multiple events that affected many countries around the world.²⁵

The basic panel model is of the generic form,

$$\sigma_{it} = \alpha + \gamma\tau_{it} + \mathbf{X}\boldsymbol{\beta} + \delta_i + \delta_t + \varepsilon_{it} \quad (3.15)$$

where σ_{it} is the logarithm of the income Gini coefficient for country i at time t , τ is

²⁴For a more extensive discussion on this see [Griliches and Hausman \(1986\)](#) and [Bound and Krueger \(1991\)](#).

²⁵Some of the most significant ones include: the early 1980s recession, the collapse of the Soviet Union in the early 1990s, the Asian Crisis in 1997 and the Great Recession starting in 2008.

the tariff rate, \mathbf{X} is a matrix of control variables, δ_i is the country time-invariant unobservable heterogeneity (country fixed effects), δ_t is the year fixed effects that capture common temporal shocks and ε_{it} captures all the omitted factors.

Despite the use of fixed effects, there are remaining endogeneity concerns that must be taken into consideration.²⁶ Tariff rates are not randomly assigned, and several confounding factors that are correlated with tariffs and inequality could bias the estimates. These factors include: the political system, financial openness, ownership structure, human capital levels, and unemployment among others. For instance, consider a government that increases tariffs to rebate this revenue to low-income workers or to protect a given industry. Such a policy implies reverse causality from inequality to tariffs. While other taxes are more effective in redistributing income, [Katsimi and Moutos \(2010\)](#) provide some evidence that governments may also use tariffs as a policy tool for redistribution, at least in the case of developing countries. Thus, we cannot completely dismiss the situation of reverse causality between income inequality and tariffs. As a result, our second strategy is the use of instrumental variable estimation in the panel context for the static model.

As a first robustness check we employ a dynamic panel as an alternative to dealing with unobserved heterogeneity. Following the discussion of [Breen and García-Peñalosa \(2005\)](#), we propose the use of lagged income inequality as an explanatory variable. The logic behind this approach is that using a lag of the dependent variable as a regressor may help deal with some of the unobserved heterogeneity. If omitted variables evolve sluggishly over time, then they will also determine inequality in the previous period, and therefore using a lag of inequality may account for some of these sluggish omitted variables. However, as shown in [Nickell \(1981\)](#), including a lag of the dependent variable as a regressor will make estimates biased and inconsistent even if the residuals are not serially correlated. Hence, we apply the difference generalized method-of-moments (GMM)

²⁶Fixed effects are preferred to the random effects specification due to the nature of the problem and the fact that the Hausman test strongly suggests the use of the former.

estimator and the system GMM estimator developed by [Arellano and Bond \(1991\)](#), [Arellano and Bover \(1995\)](#), and [Blundell and Bond \(1998\)](#); see [Voitchovsky \(2005\)](#) for further discussion of the applications of these estimators in a macroeconomic context.

The dynamic panel data model is specified by,

$$\sigma_{it} = \alpha + \mu\sigma_{it-1} + \gamma\tau_{it} + \mathbf{X}\boldsymbol{\beta} + \delta_i + \delta_t + \varepsilon_{it} \quad (3.16)$$

As a second robustness check for the impact of tariffs on inequality, we use income shares of the five quintiles of the population to investigate the distributional consequences of tariffs by applying seemingly unrelated regressions (SURE) estimation.

Tariff heterogeneity and PSTR analysis

As we have already suggested, the relationship between income inequality and tariff rates is unlikely to be homogenous across countries and over time. While we succeed in finding significant results for the intra-temporal relationship between these variables, these estimates are average effects and do not necessarily represent the relationship for any specific country. Moreover, our underlying model implies that the effects differ, depending upon the speed of tariff adjustment.

There are several potential ways to parameterize the speed, one natural way being to define it as the difference in the tariff rate between period t and the long-run equilibrium level $\bar{\tau}$, $(\tau_{it} - \bar{\tau})$. Thus, the regression model considering this effect could be written as,

$$\sigma_{it} = \alpha + \gamma_0\tau_{it} + \gamma_1\tau_{it}(\tau_{it} - \bar{\tau}) + \mathbf{X}\boldsymbol{\beta} + \delta_i + \varepsilon_{it} \quad (3.17)$$

or equivalently as,

$$\sigma_{it} = \alpha + \gamma'_0\tau_{it} + \gamma_1\tau_{it}^2 + \mathbf{X}\boldsymbol{\beta} + \delta_i + \varepsilon_{it}; \quad \gamma'_0 \equiv (\gamma_0 - \gamma_1\bar{\tau}) \quad (3.18)$$

This imposes a specific type of nonlinearity, namely, quadratic. While the data illustrated in the panels of Fig. 3.1, suggest some kind of nonlinear relationship, it need not be of this specific form. Indeed in a preliminary test, we found γ'_0 and γ_1

to be individually insignificant, but jointly significant. This suggests the relevance of a nonlinear relationship, but of a more flexible form.

To better capture this heterogeneity, we use a panel smooth transition regression (PSTR) model, introduced by [González et al. \(2005\)](#). All the details and derivations can be found in their paper; here we briefly summarized the framework.

Thus, using a PSTR model we can write the following regression,

$$\sigma_{it} = \alpha + \gamma_0 \tau_{it} + \gamma_1 \tau_{it} g(x_{it}; \lambda, c) + \mathbf{X}\boldsymbol{\beta} + \delta_i + \varepsilon_{it} \quad (3.19)$$

where $g(x_{it}; \lambda, c)$ is the transition function with transition variable x_{it} that in this case corresponds to the logarithm of the tariff and parameters λ and c . The transition function $g(\cdot)$ is normalized to be bounded between 0 and 1, so that these extreme values are associated with regression coefficients γ_0 and $\gamma_0 + \gamma_1$. $\lambda > 0$ is the speed of transition, and c denotes an m -dimensional vector of location parameter $c_1 \leq c_2 \leq \dots \leq c_m$, where these restrictions are imposed to identify potential points of regime change. The specific transition function is formulated as follows,

$$g(\tau_{it}; \lambda, c) = \left[1 + \exp \left(-\lambda \prod_{j=1}^m (\tau_{it} - c_j) \right) \right]^{-1} \quad (3.20)$$

This function is continuous in τ_{it} bounded between 0 and 1, and consequently there is a continuum of states between the two extreme regimes. Further notice that when $\lambda \rightarrow \infty$, the transition between the extreme regimes is sharp and the PSTR becomes a panel threshold model as described in [Hansen \(1999\)](#). At the other extreme, if $\lambda \rightarrow 0$, then the transition function is constant and the model collapses into a standard linear model with country fixed effects. It is important to highlight that the smooth transition regression is a more general specification of the quadratic polynomial model commonly used to study heterogeneity, in other contexts. As a result, the use of a regime-switching model as the PSTR is appealing since the polynomial approach is a particular case of the PSTR.

Now, given the scarcity of observations in our context we cannot control for many variables, so we focus on the regression that addresses the heterogeneity of

the relationship and use only country fixed effects. Thus, we run a simpler version of equation (3.19),

$$\sigma_{it} = \alpha + \gamma_0 \tau_{it} + \gamma_1 \tau_{it} g(\tau_{it}; \lambda, c) + \mathbf{X} \boldsymbol{\beta} + \delta_i + \varepsilon_{it} \quad (3.21)$$

Moreover, this analysis is non-trivial in theoretical and applied terms. It involves nonlinear optimization to find the parameters λ and c . In addition, the hypothesis tests are nonstandard because they are performed in the presence of unidentified nuisance parameters. This model implies that the tariff elasticity on income inequality will be a function of the parameters γ_0 and γ_1 . To simplify this expression we estimate the model in its log-log version rather than the log-linear version we have used in the previous methods.

Long-run effects

We estimate a cross-sectional regression for the average inequality between 1990 and 2010 on the tariff rate and other controls measured in 1990 to analyze the long-run effect of a change in the tariff rate. This methodology has been applied by [Alesina and Rodrik \(1994\)](#) and [Breen and García-Peñalosa \(2005\)](#). Our specification is as follows,

$$\bar{\sigma}_{i,1990-2010} = \alpha + \gamma \tau_{i,1990} + \mathbf{X}_{1990} \boldsymbol{\beta} + \varepsilon_i \quad (3.22)$$

Even though this method can provide some insight into the long-run effect of tariffs on inequality, it is not sufficient to argue causation. Thus, as a robustness check we implement a long-difference regression to study the impact of tariff changes on inequality changes over a 17-year period going from 1992 to 2008. In this case, our empirical specification is,

$$\Delta \sigma_i = \alpha + \gamma (\Delta \tau)_i + \mathbf{X}_{1992} \boldsymbol{\beta} + \varepsilon_i \quad (3.23)$$

where $\Delta \sigma_i$ and $\Delta \tau_i$ correspond to the differences in income inequality and tariffs in country i , respectively, computed as the level of inequality/tariff in the last period minus the level in the first one. All other explanatory variables take their value at the beginning of the period.

3.3.3 Specification

The main objective of our empirical analysis is to use data across countries and over time to estimate the overall effect of tariffs on income inequality. In the formal model we use the coefficient of variation as a measure of relative income inequality; hence, being widely available, the income Gini coefficient is the convenient measure of inequality to map the theory into the data. Notice that we do not attempt to fit the model to some subset of moments by changing structural parameters, but rather we want to test the causal validity of the implications with respect to inequality and tariffs implied by our stylized theory. We do this by using a reduced-form model that includes many of the other elements influencing inequality considered in the literature.²⁷ This is to reduce the possible omission variable bias, as well as to quantify some of the other factors affecting income inequality.

The set of control variables most directly relevant to this relationship include the following: (i) Exports and imports, as alternative measures to tariffs of trade openness; (ii) Foreign direct investment, portfolio equity, debt and financial derivatives. All of them summarized in financial liabilities and financial assets ([Lane and Milesi-Ferretti \(2007\)](#)) and capital account openness ([Chinn and Ito \(2008\)](#)), as measures of financial openness, both indirect features of our model; (iii) Domestic credit as a measure of financial deepening. This is not explicitly incorporated in our theoretical framework, nonetheless, it must be considered if we want to avoid misspecification biases.

Other regressors less directly relevant for tariffs but nevertheless related to inequality include: (iv) Years of schooling and the fraction of the population with secondary schooling ([Li et al. \(1998\)](#)); (v) The role of labor market frictions and how relative labor productivity can account for it ([Bourguignon and Morrisson \(1998\)](#)); (vi) Information and communications technologies ([Jaumotte et al. \(2013\)](#)); (vii) Unemployment, which may increase or decrease due to changes

²⁷See [Forbes \(2000\)](#), [Voitchovsky \(2005\)](#), [Bergh and Nilsson \(2010\)](#) and [Jaumotte et al. \(2013\)](#).

in tariff policy, thereby affecting inequality and biasing our estimate for tariffs if excluded from the econometric model; (viii) Lastly, civil rights are a measure for the relative bargaining power of different groups. More details regarding the variables are provided in Appendix B.²⁸

3.4 Results

As noted in Section 3.3.1 the sample consists of 73 countries with varying numbers of observations depending upon when and how frequently they report their tariffs and measure their inequality. As a result, the panel is highly unbalanced and hence the number of countries and observations available in the different regressions is not the same. This restricts the comparisons that can be made across model specifications.

3.4.1 Tariffs and Inequality

The results for the panel estimation with country and year fixed effects are summarized in Table 3.1. We have estimated different model specifications. The full model, reported in column (1), contains the most widely employed variables used in this type of analysis. The controls include: measures of international trade, financial integration, domestic financial development, human capital, labor market imperfections, technology and political system. This is done as an attempt to reduce the omitted variable bias due to characteristics that change over time. However, this equation is not our preferred specification (reported in col. 2) basically because of the high collinearity of all these variables that severely decreases the significance of individual variables that are, however, jointly significant.²⁹ Hence, we perform three other regression to detect the direction of the effect of the tariff on inequality.

²⁸The Box-Cox transform suggests the functional forms adopted for the different variables. For more discussion of this issue see [Box and Cox \(1964a\)](#) and [Aneuryn-Evans and Deaton \(1980\)](#).

²⁹We also estimate a naïve regression of only tariffs on inequality and we obtain a negative sign that is not statistically significant by the order of magnitude is similar to the ones reported in Table 3.1.

Table 3.1: Income inequality and tariff reduction panel regressions: Log(Gini)

	Full Model (1)	Benchmark Model (2)	Reduced Model (3)	IV Model (4)
Tariff Rate	-0.0036*** (-3.22)	-0.0039*** (-2.81)	-0.0038*** (-2.81)	-0.0054** (-1.98)
Exports	0.0001 (0.09)			
Imports	0.0015 (0.69)			
Financial Liabilities	0.0006*** (1.88)	0.0003*** (3.14)	0.0003*** (2.83)	0.0003*** (3.07)
Financial Assets	-0.0005*** (-1.75)			
Capital Acct. Open.	-0.0005 (-0.08)			
Domestic Credit	0.0007 (1.38)	0.0007* (1.84)	0.0008** (2.08)	0.0007*** (2.19)
Unemployment	0.0041 (1.55)	0.0047* (1.89)	0.0046* (1.94)	0.0031 (1.46)
RLP agriculture	-0.0024 (-0.56)			
Years of Schooling	0.0095 (0.05)	-0.1013 (-0.61)		-0.1254 (-1.07)
Fraction with Sec. Sch.	-0.0024 (-1.20)	0.0005 (0.27)		0.0007 (0.42)
Inf. & Comm. Tech.	0.0087* (1.96)	0.0116** (2.37)	0.0120*** (2.54)	0.0083** (2.14)
Civil Rights	0.0025 (0.21)			
Observations	310	334	334	294
# Countries	35	37	37	32
Adjusted R^2	0.221	0.217	0.220	-
Kleibergen-Paap test (p -value)				0.03

Notes: * $p < 0.10$, ** $p < 0.05$, *** $p < 0.01$. Standard errors are clustered at country level. t statistics are reported in parentheses.

All specifications are panel regressions with country and year fixed effects. The instrumental variables for the tariff correspond to the second lag of itself and political rights from the Freedom House. The instruments for information and communications technologies are exports and imports from high-income countries. The dependent variable, Gini, is defined in the range 0 to 100 with the usual meaning. All explanatory variables are expressed in terms of percentage of GDP, except the tariff rate, unemployment and fraction of the population with secondary schooling that are expressed in percentage points. Years of schooling is expressed in years, capital account openness is an index between 0 (very open) and 1 (very closed), civil rights is an index between 1 (free) and 7 (not free). Relative labor productivities are in units of the corresponding output. Most variables are in their levels, except RLP, ICT and schooling that are in logs.

To increase the number of observations, we reduce the number of explanatory variables.³⁰ After performing different joint significance tests, we obtain the benchmark model, reported in column (2). Next, we run another regression, eliminating some other explanatory variables, but preserving the sample - same countries and same years. This is reported in column (3). We observe that the estimate on tariffs is slightly smaller than in the case with more controls. This suggests the possibility that the omitted variable bias could decrease the size of the average effect of the tariff rate on income inequality. However, determining the bias depends upon the way the variables are correlated with each other and the endogeneity of other variables. Hence, affirming the sign of the bias with certainty is not possible. Nevertheless, and given our multiple robustness checks, we are confident of the sign of the tariff effect on inequality in the short run.

To address the endogeneity concern from simultaneity, we use a two-stage-least-square (2SLS) estimation using instrumental variables for the tariff. This is reported in column (4), which allows for endogeneity of the tariff. The instruments for the tariffs are the second lag of itself, and the political rights index. These instruments may a priori be correlated with current tariffs but not with other causes of inequality summarized in the error term. In order to test for the validity of these instruments we undertake two tests.³¹ First, we apply the Kleibergen-Paap test, which is an under-identification test with the null hypothesis stating that the canonical correlations between the endogenous regressor and the instruments are zero. We reject this hypothesis at the 5% significance. Second, we perform the over-identification or exclusion restriction test under the null hypothesis that instruments are uncorrelated with the error term. We fail to reject the null hypothesis at the 10% significance level. Hence, our instruments appear to be appropriate. Overall, the IV estimate is supportive of the effect of the ta-

³⁰The major problem is that for a given country some variables are measured during a given period but others are not. This drops all other observations for that period, which reduces the overall number of observations. We avoid linear interpolation.

³¹We use the hypothesis tests developed by [Kleibergen and Paap \(2006\)](#) and by [Hansen \(1982\)](#), respectively.

riff rate on income inequality as seen in column (4). However, we must remember that the IV estimator has less precision than does the OLS, and their finite-sample properties are problematic. Therefore, their use in a small sample context must be viewed with caution, raising the need for further analyses.

Before describing the effects of the different control variables on income inequality, we may note that the estimate for the tariff rate is statistically significant and rather stable around -0.0037. This result suggests causation between the reduction of the tariff and the increase in income inequality measured by the income Gini coefficient. Recalling that σ is the logarithm of the Gini coefficient, this implies that a 10 percentage point reduction in the tariff will increase income inequality by around 3.7% in the short run. This is comparable to the numerical simulations of [Rojas-Vallejos and Turnovsky \(2015\)](#) who found that for a similar tariff reduction, inequality should increase by around 2% for a debtor country and somewhat less for a creditor country. Thus, the model succeeds in explaining most of the variation in the data. Furthermore, the empirical results broadly support the cases analyzed with numerical simulations, consolidating the main mechanism discussed in the theoretical section.

From column (3) in [Table 3.1](#), we observe that the main determinants of income inequality are: the tariff rate, financial liabilities, domestic credit to the private sector, unemployment and the degree of technology measured by the contribution of information and communications technology to GDP. We also observe that an increase in financial liabilities, domestic credit, unemployment or technology will tend to worsen inequality. This is somewhat confirmed in our treatment of endogeneity. Most of these results are consistent with the findings in [Jaumotte et al. \(2013\)](#) with two main differences. First, we obtain the opposite sign for the tariff. Second, we include unemployment as an explanatory variable that can be correlated with the tariff and turns out to have a significant negative effect on inequality, a finding relatively intuitive and extensively discussed by [Galbraith \(1998\)](#) and [Carpenter and Rodgers \(2004\)](#). This apparent difference between our study and theirs could be due to the way in which endogeneity is treated, the mo-

Table 3.2: GMM Estimation: Log(Gini)

	GMM-DIF	GMM-SYS	GMM-DIF	GMM-SYS
	(1)	(2)	(3)	(4)
Tariff Rate	-0.0061*	-0.0011	-0.0088*	-0.0051*
	(-1.84)	(-0.27)	(-1.64)	(-1.81)
Financial Liabilities	0.0000	-0.0003	0.0008	-0.0001
	(0.02)	(-1.20)	(1.57)	(-0.68)
Domestic Credit	0.0008	-0.0003		
	(0.67)	(-0.34)		
Unemployment	0.0280***	-0.0176		
	(2.53)	(-1.33)		
Inf. & Comm. Tech.	0.0226**	-0.0106		
	(2.08)	(-0.65)		
Years of Schooling	-0.9750**	-0.2868	-0.3129	-0.4310***
	(-1.98)	(-1.02)	(-0.71)	(-3.09)
Fraction with Sec. Sch.	0.0109**	-0.0061		
	(2.00)	(-1.41)		
Gini($t - 1$)			0.4508**	0.5068***
			(2.00)	(3.18)
Serial Correlation (p -value)	0.32	0.11	0.92	0.73
Hansen J -test (p -value)	0.91	0.87	0.88	0.79
Observations	105	147	127	184
# of instruments	34	46	19	28

Notes: 1. Year dummies are included in all specifications. Two-step estimation with [Windmeijer \(2005\)](#) finite sample correction. * $p < 0.10$, ** $p < 0.05$, *** $p < 0.01$. t statistics are reported in parentheses. Gini($t - 1$) is the logarithm of the lagged Gini, other variables defined as in [Table 3.1](#).

2. All variables are instrumented by lags of themselves.

3. Serial correlation test for second-order serial correlation in the first-differenced residuals, asymptotically distributed as $N(0, 1)$ under the null of no serial correlation.

4. Hansen J -test is a test of over-identifying restrictions, asymptotically distributed as χ^2 under the null of instrument validity, with the degrees of freedom reported in parentheses.

del specification, and the dataset on inequality that in our case comes only from income surveys rather than income and expenditure surveys. Nonetheless, most of the results are quite comparable and the main driving forces of inequality, namely, financial liabilities, domestic credit, and technology are similar in signs and magnitude.

Next, from a political economy perspective, we could also argue that the greater the concentration of income, the greater the concentration of political power in special interest groups. Therefore, regulations and policies will tend to be designed to benefit more those at the top of the income distribution. From this standpoint, the positive sign in the estimates of lagged inequality in the dynamic model shown in Table 3.2 is not unexpected. Furthermore, Table 3.1 shows that civil rights, our proxy for the level of democracy, are not significant. This implies that the political and economical elite impact redistribution more than the electorate. This finding is also obtained in other studies and discussed in detail in [Alesina and Rodrik \(1994\)](#).

Table 3.2 reports the estimates of the dynamic panel model in equation (3.16) together with GMM estimates of a static model. This serves as our second strategy to answer the causal question. This table confirms that our results for tariffs using the static panel model are robust under the dynamic specification, with the effect having a similar magnitude, but slightly lower significance than those reported in Table 3.1. In addition, we observe that income inequality is persistent over time, which again is consistent with the numerical simulations, particularly for debtor economies. Past values of inequality seem to contribute to increase current inequality as explained above. Columns (1) and (3) of Table 3.2 correspond to the difference GMM estimator for two alternative models in which all explanatory variables are treated as endogenous with the sole exception of the time-specific effects that are regarded as exogenous. These estimates are negative and significant which support our previous finding. As pointed out by [Voitchovsky \(2005\)](#) due to the stability of inequality over time, the system GMM estimator can make more efficient use of the limited information in this context and hence these results are

presented in columns (2) and (4) of Table 3.2. There we have weaker evidence of the adverse effect of tariff reduction on inequality, but still with the predicted sign by our theory.³²

Both measures of income inequality, the Gini coefficient and the coefficient of variation, are measures of average inequality across the whole distribution of agents. While reducing the tariff increases overall inequality, it is of interest to determine which parts of the distribution are most affected. Table 3.3 addresses this question by summarizing the impact of tariffs across quintiles. From the table we observe that a tariff reduction of 10-percentage points decreases the income share of the poorest quintile by 6.2%.³³ The same reduction does not significantly affect the income share of the second and third quintiles. At the same time, it increases the income share of the fourth quintile by 2.7%, while there are no significant effects on the richest quintile.

One conjecture for the pattern shown in Table 3.3 is that the income from the bottom group primarily reflects wages of unskilled labor, which with tariff liberalization are adversely affected from the increase in competition from foreign firms. Similarly, the fourth quintile, which is more associated with higher educational attainment and technical skills, shows that the opportunities brought by tariff liberalization may increase their income share because they can take better advantage of them. The richest group, on the other hand, because they devote a small share of their income to consumption, are less sensitive to reductions in tariffs in terms of their relative income share. These responses are broadly consistent with the theoretical results summarized in Section 3, where individuals above the mean of the income distribution enjoy an increase in their income share, while those below average experience a decline.

Another result in Table 3.3 worth noting is that domestic financial development, as reflected by an increase in domestic credit, will redistribute income from

³²The control variables are the ones in our benchmark model.

³³This number is obtained multiplying the parameter estimate by the 10-percentage points tariff reduction and dividing that by the mean share of income of this quintile.

Table 3.3: SURE Estimation for Inequality by Income Shares

	Q1 (Poorest)	Q2	Q3	Q4	Q5 (Richest)
Tariff Rate	0.037* (1.78)	0.025 (1.27)	-0.007 (-0.38)	-0.058*** (-3.29)	0.004 (0.06)
Domestic Credit	-0.013*** (-3.45)	-0.018*** (-5.08)	-0.016*** (-5.13)	-0.011*** (-3.55)	0.059*** (5.27)
Unemployment	-0.018 (-0.86)	-0.024 (-1.20)	-0.032* (-1.77)	-0.026 (-1.44)	0.101 (1.59)
Years of Schooling	1.359 (1.09)	3.204*** (2.67)	4.749*** (4.38)	3.667*** (3.45)	-12.775*** (-3.39)
Information & Communications Tech.	-0.114 (-1.28)	-0.014 (-0.16)	-0.039 (-0.50)	-0.010 (-0.13)	0.162 (0.60)
Observations	184	184	184	184	184
# of Countries	28	28	28	28	28

Notes: The regressions were estimated jointly using Seemingly Unrelated Regressions (SURE) on net income shares by quintiles. * $p < 0.10$, ** $p < 0.05$, *** $p < 0.01$. t statistics are reported in parentheses. All regressions include country fixed effects and time dummies. Variables defined as in Table 3.1. In addition, the income share by quintiles are defined in percentage points. Breusch-Pagan test strongly rejects the null hypothesis of independence of the equations.

the bottom quintiles to the top 20%. However, what may be happening is that individuals at the top of the income distribution can make better use of the new opportunities provided by financial development. Thus, while everyone may have increased their incomes, the relative share is more skewed toward the rich.

3.4.2 Speed of tariff reduction and long-run effect on inequality

Testing the hypotheses associated with the impact of the speed of tariff adjustment and the long-run effect of tariffs on inequality is less direct. One of the main problems for the former is that although most countries have generally reduced their tariffs over the period 1984-2010, they have typically not done so strictly

monotonically. Thus the impact on inequality described in Hypothesis 3.4, which characterizes monotonic changes, is not strictly applicable. Nevertheless, because countries have predominantly reduced tariffs at varying rates, we have tried to test this hypothesis, insofar as possible, by means of a PSTR model as reported in Table 3.4. We apply this methodology in a balanced panel context, given that most of the available statistical tools have been developed in absence of missing values. We first construct a balanced panel by taking averages of the variables for 5-year periods as done by Forbes (2000) and others. Using the resulting balanced panel of 17 countries with 5 periods, we then apply the procedure described in Section 3.3.2. Therefore, we first test the homogeneity assumption. We reject that at the 5% significance level. Then we proceed to test the parameters involved in the auxiliary regression defined by the first-order Taylor expansion of equation (3.21) assuming that the transitional function given by (3.20) has its parameter $m = 2$.³⁴ We observe that the null hypothesis $H_0^* : \gamma_1^* = 0 | \gamma_2^* = \gamma_3^* = 0$ is the one with the strongest rejection and following the arguments given by Teräsvirta (1994), we select the transition function with the logistic form, that is, $m=1$.

Next, we test the hypothesis of linearity against the PSTR model with the logistic transitional function. We reject the null at 1% significance level. Thus, we carry out the estimation of the PSTR model. We find that γ_0 is not statistically significant while γ_1 the parameter associated with the heterogeneous effect is significant at the 1% level. This implies that the impact of tariff reduction on income inequality is highly sensitive to the level of the tariff, as the panels of Fig. 3.1 suggest. The parameter estimates reported in Table 3.4 suggest that the link between tariffs and inequality is described by,

$$\sigma_{it} = 0.029x_{it} - 0.063x_{it} (1 + e^{-2(x_{it}-2.76)})^{-1} \quad (3.24)$$

where $x_{it} \equiv \ln \tau_{it}$. This implies that the coefficient of $\ln \tau_{it}$ in the regression varies between 0.029 to -0.034. Plotting $\partial \sigma_{it} / \partial x_{it}$ we find that decreasing the tariff reduces income inequality for values of $\tau_{it} < 6\%$, while it increases inequality

³⁴According to González et al. (2005) it is usually sufficient to perform the analysis with $m \in \{1, 2\}$.

Table 3.4: An Indirect Test for the Speed of Tariff Reduction

	PSTR	
	Coef.	t-Stat
Tariff Rate (γ_0)	0.029	1.06
Transition Variable (Tariff)		
Tariff Rate (γ_1)	-0.063***	-2.69
Transition Parameters		
\hat{c} (Tariff rate threshold)	15.8%	
$\hat{\lambda}$	2.00	
Homogeneity Tests		
		<i>p</i> -value
$H_0^* : \gamma_1^* = \gamma_2^* = \gamma_3^* = 0$		0.04
$H_0^* : \gamma_3^* = 0$		0.74
$H_0^* : \gamma_2^* = 0 \gamma_3^* = 0$		0.67
$H_0^* : \gamma_1^* = 0 \gamma_2^* = \gamma_3^* = 0$		0.01
Linearity Test against PSTR		
with $m = 1, r = 1$		0.01
No Remaining Heterogeneity Test		0.82
Parameter Constancy Test		0.32

Notes: * $p < 0.10$, ** $p < 0.05$, *** $p < 0.01$. The dependent variable is the logarithm of the income Gini coefficient and the explanatory variable is the logarithm of the tariff rate that is expressed in percentage points. There are no other explanatory variables.

The sample consists of 17 countries over 5 periods of time of 5 years each from 1985 to 2010. The tariff rate threshold is the antilogarithm of the estimated threshold 2.76.

for $\tau_{it} > 6\%$. Since rich countries have historically had low tariffs, this suggests that reducing tariffs is likely to have little effect on their inequality, perhaps to

reduce it slightly, while raising inequality for poorer economies. Since our sample is dominated by emerging or poorer economies for which the average tariff exceeds the threshold, this is consistent with our earlier results indicating a positive relation between tariff reduction and income inequality.

Lastly, we test for remaining heterogeneity and parameter constancy. The data suggest that there is no remaining heterogeneity and that the parameter is time-stable. However, this must be viewed with caution since the sample size is small and the model specification is very parsimonious. Nonetheless, this analysis provides some support in favor of Hypothesis 3.4.

Table 3.5: Long-run Effect: Log. of Avg. Gini 1990 to 2010.

	ATG Database			SWIID Database		
	Full (1)	Benchmark (2)	Reduced (3)	Full (4)	Benchmark (5)	Reduced (6)
Tariff Rate	-0.0115 (-1.15)	-0.0036 (-0.64)	-0.0061 (-1.16)	-0.0096** (-2.77)	-0.0049*** (-3.14)	-0.0039** (-2.13)
Observations	20	24	24	25	30	30
Adjusted R^2	0.81	0.49	0.48	0.79	0.57	0.52

Notes: * $p < 0.10$, ** $p < 0.05$, *** $p < 0.01$. Standard errors are robust. t statistics are reported in parentheses. The controls in each column correspond to the respective full, benchmark and reduced models presented in Table 3.1.

The long-run effect is studied as described in Section 3.3.2. We find weak evidence of tariffs having a permanent effect on income inequality. Our main dataset based on the ATG database, but we also use the SWIID database as a robustness check. Table 3.5 and 3.6 show that most estimates have a negative sign but fail to be significant. This suggests that the long-run effect of tariffs on inequality in the long run is rather small. To some extent, this is consistent with our numerical simulations for debtor countries that show a stronger effect of tariff reduction in the short run rather than in the longer run. However, we should

point out that obtaining significant results on changes as reported in Table 3.5 is hard. For example, Edwards (1997) and Dollar and Kraay (2004) apply a similar methodology to ours and they fail to find significant results of the relationship of trade variables on income inequality. Milanovic and Squire (2005) discuss this issue in greater detail.

Table 3.6: Long Difference Regression: Diff. Log. of Gini 1992 & 2008.

	SWIID Database		
	Full (1)	Benchmark (2)	Reduced (3)
Diff(Tariff Rate)	-0.0044 (-1.00)	-0.0029 (-1.03)	-0.0028 (-1.00)
Observations	20	21	21
Adjusted R^2	0.47	0.37	0.33

Notes: * $p < 0.10$, ** $p < 0.05$, *** $p < 0.01$. Standard errors are robust. t statistics are reported in parentheses. The controls in each column correspond to the respective full benchmark and reduced models presented in Table 3.1.

3.4.3 Output and Inequality

As noted in the introduction, there is a large literature examining the impact of inequality on aggregate activity. While much of this focuses on the growth of output, in the context of the growth-inequality tradeoff, in our case, given the stationarity of the long-run equilibrium, the level of output is the more appropriate metric. As also noted, given the homogeneity assumption underlying our theoretical model, inequality should have no effect on aggregate output. Table 3.7 introduces the Gini as an explanatory variable in a number of regressions. In all cases its impact is small, but to the extent that it is statistically significant may be viewed as a

rejection of homogeneity, which in any event is a strong assumption.

Table 3.7: The Effect of Income Inequality on Output: Log. of income per-capita

	Pooled OLS (1)	OLS & Controls (2)	Country FE (3)	Full FE (4)	FE & Controls (5)	IV Model (6)
Gini	-1.856*** (-5.25)	-0.756* (-1.71)	0.211 (0.63)	0.010 (0.51)	0.330** (2.17)	1.525* (1.87)
Tariff Rate		-0.040*** (-2.61)			-0.021*** (-4.50)	-0.020*** (-5.86)
Country FE	No	No	Yes	Yes	Yes	Yes
Year FE	No	No	No	Yes	Yes	Yes
Controls	No	Yes	No	No	Yes	Yes
Observations	1357	334	1357	1357	334	247
# of Countries	121	37	121	121	37	25
Adjusted R^2	0.148	0.676	0.005	0.670	0.781	-
Kleibergen-Paap test (p -value)						0.03
Hansen J statistic (p -value)						0.44

Notes: * $p < 0.10$, ** $p < 0.05$, *** $p < 0.01$. Standard errors are clustered at the country level. t statistics are reported in parentheses. Controls are the same as the ones in Table 3.1, benchmark specification. The Gini is instrumented with the third lag of itself and total fertility rate. Statistics are robust to heteroscedasticity and autocorrelation. Variables defined as in Table 3.1 and Gini correspond to the logarithm of itself. In addition, the dependent variable, GDP per-capita, is in units of constant 2005 US dollars per person.

Columns (1) and (2) are pooled OLS regressions, analogous to the growth equation estimated by [Alesina and Rodrik \(1994\)](#) and imply a significant negative relationship between inequality and output, as do they. The striking feature of Table 3.7 is that as one introduces country and year fixed effects and uses the panel structure of the data, the sign of the relationship changes from negative to positive. In this respect our results are closer to those of [Forbes \(2000\)](#), who also introduces country and year fixed effects and obtains a similar positive relationship. Moreover, the evidence of a positive relationship is strengthened by the use of instrumental variables, reported in the final column.³⁵ This pattern of results suggests that the

³⁵This result must be interpreted with caution since the number of countries is only 25.

negative impact of inequality on growth, obtained in some of the earlier work, may in fact be just reflecting the negative biases due to the econometric modeling and specific sample characteristics.

3.4.4 Output and Tariffs

As shown in our theoretical framework, a tariff reduction will increase short-run and long-run

Table 3.8: Output Regressions With No Inequality: Log. of income per-capita

	Pooled OLS	OLS & Controls	Country FE	Full FE	FE & Controls	IV Model
	(1)	(2)	(3)	(4)	(5)	(6)
Tariff Rate		-0.040*** (-2.61)			-0.021*** (-4.50)	-0.020*** (-5.86)
Country FE	No	No	Yes	Yes	Yes	Yes
Year FE	No	No	No	Yes	Yes	Yes
Controls	No	Yes	No	No	Yes	Yes
Observations	1357	334	1357	1357	334	247
# of Countries	121	37	121	121	37	25
Adjusted R^2	0.148	0.676	0.005	0.670	0.781	-
Kleibergen-Paap test (p -value)						0.03
Hansen J statistic (p -value)						0.44

Notes: * $p < 0.10$, ** $p < 0.05$, *** $p < 0.01$. Standard errors are clustered at the country level. t statistics are reported in parentheses. Controls are the same as the ones in Table 3.1, benchmark specification. The instruments for the tariff rate are the second lag of itself and the civil rights index. Variables defined as in Table 3.5.

output. The empirical evidence confirms the contemporaneous expansionary effect of a tariff reduction. From columns (5) and (6) of Table 3.7, we see that a one-percentage point reduction in the tariff leads to an increase in output of around 2%. This allows for the effect of inequality. We re-estimate this relationship but without inequality in the model, enabling us to include many more observations. These outputs are shown in Table 3.8. We again observe a contractionary effect of the tariff on output, but now much smaller. This time a reduction of one-percentage

point in the tariff rate leads to a 0.5 percent increase in output. In both cases, the increase in output is a bit larger than that predicted by the calibrated version of the theoretical model, which predicts a reduction in output of around 0.1 percent by one-percentage point reduction in the tariff. Column (5) of Table 3.8 shows the IV model that addresses concerns of reversed causality. We can see that the estimate is rather stable and has the expected sign.

3.5 Conclusions

This paper has explored the relationship between tariff reductions and income inequality using panel data for 73 countries over the period 1984 to 2010, a period characterized by extensive tariff reduction together with a significant increase in intra-national income inequality. We find that a permanent reduction in tariff rates will increase short-run income inequality with a negligible effect of long-run inequality. The qualitative response is consistent with the numerical simulations obtained using the underlying framework developed by [Rojas-Vallejos and Turnovsky \(2015\)](#). To a lesser extent, the magnitudes of these responses follow the prediction of the theory here presented. The empirical evidence provides some support for the statement that the speed of tariff adjustment has an effect on income inequality. Since poorer economies starting with higher tariffs tended to reduce them more rapidly, this evidence supports the view that the impact of tariffs on income inequality are sensitive to the country's level of development. But to establish such a relationship more definitively will require a more extensive dataset covering more frequent tariff adjustments, or perhaps country-case studies. Another implication of the model is that the income shares of agents having above-average income benefit relatively more from tariff liberalization, while individuals below are relatively worse off. To test for this we have estimated the impact of tariffs on income shares by quintiles. We find that while the relative income of the lowest quintile is the most adversely affected, the greatest beneficiaries are the agents in the second richest quintile.

Since income distribution and aggregate activity are jointly determined, we

have also considered the impact of tariff reductions on the latter. Our empirical analysis confirms the conventional result that tariff reductions have an expansionary effect on aggregate output. Finally, we also use the model to examine the impact of income inequality on output, and find that when estimated using the panel specification, inequality has a significant positive contemporaneous impact on output.

All this suggests that reducing tariffs involves at least a short-run tradeoff between increasing the level of economic activity coupled with more income inequality. This is rather important and is a factor for policymakers to consider when designing tariff policy.

Because of data limitations as is typically the case in empirical studies of inequality, our results cannot be viewed as being definitive. More observations would be needed, particularly to address issues pertaining to the heterogeneous effects of tariff reductions. Nonetheless, by adopting a panel data approach, and including a wide range of control variables, we are confident that the relationship established is indeed causal, rather than reflecting a spurious correlation.

Finally, we should note some caveats. First, our analytical framework and empirical estimation are based on a one-sector economy and are restricted to tariffs on consumption. But many economies have imposed tariffs on imported investment goods, and of course the impacts of tariffs are felt differentially throughout different sectors in the economy. Second, in addition to tariff rates, financial development, technology, and unemployment seem to be the most important determinants of income inequality. As noted, these other variables have been introduced as controls, mainly to make use of the conditional independence assumption that allows us to have a causal interpretation of the parameter of interest. Nevertheless, the determination of income inequality is a complex issue, particularly in the international economy. To get a more complete picture of its determination further research should be undertaken to analyze in more detail the effects of these other factors.

Chapter 4

THE DISTRIBUTIONAL CONSEQUENCES OF TARIFF LIBERALIZATION: A THEORETICAL APPROACH

Tariff reductions have distributional effects on wealth and income. Whether inequality increases or decreases depends upon the specific tariff shock and some key structural elements of the economy. The nature of the tariff shock matters not only for the magnitude of the effect, but also for its sign. A tariff reduction on consumption has different effects than a tariff reduction on capital. Similarly, whether this reduction is implemented slowly or quickly matters not only for the long-run outcome but also for the transitional behavior of inequality. That is, depending upon the way in which the economy is liberalized will imply different time paths for income inequality as well as for wealth inequality.

Most of the mainstream literature has often focused on understanding the behavior of the aggregate economy in terms of output and prices, but neglecting to some extent its distributional consequences. The reason for the absence of inequality in the debate is partially related to analytical difficulties. The objective of this paper is to investigate the consequences of the Great Liberalization that occurred between the 1970s and the 2000s.

We build a two-sector dependent-economy model with traded- and nontraded-capital goods and with heterogeneous agents in their initial endowments of wealth. This economy imports a consumption good and an investment good (equipments), both of which are subject to different tariffs.¹ This framework is sufficiently general to analyze the inequality responses to tariff reductions of a wide range of developing nations. We may vary both traded and nontraded capital intensities across

¹This model builds upon [Brock and Turnovsky \(1993\)](#), [Brock and Turnovsky \(1994\)](#), [Osang and Pereira \(1996\)](#), [Osang and Turnovsky \(2000\)](#), [Guilló and Perez-Sebastian \(2007\)](#), [Bouza and Turnovsky \(2012\)](#), [Rojas-Vallejos and Turnovsky \(2015\)](#).

sectors, the speed of tariff adjustments, and other structural parameters such as productivity, depreciation rates, preference and borrowing parameters. [Brock and Turnovsky \(1994\)](#) discuss in detail the flexibility of this sort of dependent-economy model within the representative agent framework, and contrast it to other versions that make more restrictive assumptions in terms of types of capital and sectoral intensities.²

A motivation to model the economic system in this way stems from the fact that consumption tariffs and capital tariffs have different levels and have been reduced at dissimilar speeds around the world. The main source for these differences is the level of development. For instance, China in 1985 had a tariff on capital of 35.36% and a tariff on consumption of 78.71%, while in 2000 the tariff rates were 13.36% and 24.69%, respectively. This represents a reduction of more than 20 percentage points on capital tariffs and more than 50 percentage points on consumption tariffs. At the same time, the United States in 1989 had tariffs of 4.01% and 7.63% on capital and consumption, respectively. In the year 2000, those tariffs were 1.73% and 6.37% representing a reduction of less than 3 percentage points. This behavior seems to be systematic between emerging and advanced economies. For a more detailed discussion on this; see [Estevadeordal and Taylor \(2013\)](#) and [Lehmann and O'Rourke \(2011\)](#).

Because of the complexity of the model, we rely on numerical simulations calibrated to a plausible economy rather than a specific country. Depending upon the parameter values of the model, we may observe a variety of responses for the transitional dynamics and the steady-state levels of the aggregate economy as well as the distributional measures. Thus, this model is more flexible to the one developed in Chapter 2. We perform one example in which the traded sector is more traded-capital intensive, while the nontraded sector is more nontraded-capital intensive.

The driving force behind these dynamics is strongly related to the returns on

²See for example [Balassa \(1964\)](#), [Samuelson \(1964\)](#), [Swan \(1960\)](#), [Engel and Kletzer \(1989\)](#), [Ostry \(1991\)](#), [van Wincoop \(1993\)](#), [Dornbusch \(1980\)](#), [Bruno \(1982\)](#).

traded and nontraded capital. [Atkinson \(2003\)](#) and [Piketty and Goldhammer \(2014\)](#) argue that the return on capital is crucial to understand the evolution of inequality. Hence, the importance of building a model with different types of productive capital and sectors. On the other hand, [Stewart and Berry \(2000\)](#) and [Goldberg and Pavcnik \(2007\)](#) find that the impact of liberalization has been larger in developing countries possibly a consequence of underdeveloped financial markets and limited access to them. Because of this, we also assume that the economy has access to the international capital market, but it faces frictions associated with its state of development.³

Our theoretical framework follows the tradition of the “Representative Consumer Theory of Distribution” (RCToD). This modeling technique relies on the aggregation properties of homothetic utility functions discussed in [Gorman \(1953\)](#) and the specific sources of inequality described in [Caselli and Ventura \(2000\)](#). [García-Peñalosa and Turnovsky \(2006\)](#) highlight the tractability and usefulness of this type of model by applying it to the relationship between economic growth and income inequality. Notice that the model presented here addressed causality going from the macroeconomic aggregates to inequality, but not the reverse. As demonstrated by [Sorger \(2000\)](#), in a completely general setup, in which the macro aggregates and inequality are mutually dependent, their joint determination and analysis becomes intractable.

There are alternative assumptions and theoretical settings to answer similar questions. For example, [Aiyagari \(1994\)](#) and [Huggett \(1993\)](#) focus on financial constraint to study inequality, while [Krusell and Smith \(1998\)](#) include preference heterogeneity in addition to assuming idiosyncratic shocks being partially uninsurable. [Fajgelbaum et al. \(2011\)](#) develop a model that incorporates heterogeneous preferences and product differentiation within a stochastic environment, while [Grossman and Helpman \(2014\)](#) introduce innovation within this framework.

Our work differs from theirs mainly in the focus and the source of inequality.

³The upward-sloping supply curve of debt assumption also induces stationarity of the equilibrium dynamics. For further details; see [Turnovsky \(1997\)](#) and [Schmitt-Grohé and Uribe \(2003\)](#).

We acknowledge the importance of financial constraints to understand the evolution of inequality. However, it is significant to also comprehend the response of returns on capital and wages to a tariff liberalization policy. Regarding the source of inequality, as discussed by [Piketty \(2011\)](#) and [Stiglitz \(2013\)](#), initial endowments are arguably the most prominent reason behind inequality. Initial endowments of wealth are strongly correlated to future outcomes such as educational attainment, access to credit, networks and salaries.

The rest of this chapter is organized as follows. Section [4.1](#) sets out the analytical framework, while Section [4.2](#) derives and characterizes the macroeconomic equilibrium. Section [4.3](#) characterizes the distribution of wealth and income. Section [4.4](#) analyzes the effects of various tariff reductions on wealth and income inequality. Section [6.4](#) concludes, while technical details are presented in appendices [C.1](#), [C.2](#) and [C.3](#).

4.1 The Model

The basic setup for the model is a small open economy (SOE) with a traded sector, Y_T , and a nontraded sector, Y_N . Households consume a domestically produced traded good, C_T , a nontraded good, C_N , and an imported consumption good, C_F , that is subject to a tariff τ_c . They also invest on two types of capital. Nontraded capital called structures, S , that is domestically produced in the nontraded sector, and traded capital called equipments, E , that is imported and subject to a tariff τ_e . Individuals are heterogeneous in their initial endowments of structures, equipments, and internationally traded bonds, B . The role of the government is to set the tariff policy and rebate the revenues back to households. Notice that we consider two sectors in the model since the asymmetric effects across sectors of the tariff policy documented in the literature; see for example [Brock and Turnovsky \(1993\)](#) and [Osang and Turnovsky \(2000\)](#). Figure [4.1](#) shows a diagram describing the main elements configuring the dynamic economic system and its flows.

Next, we setup the mathematical model detailing each element represented in the above diagram.

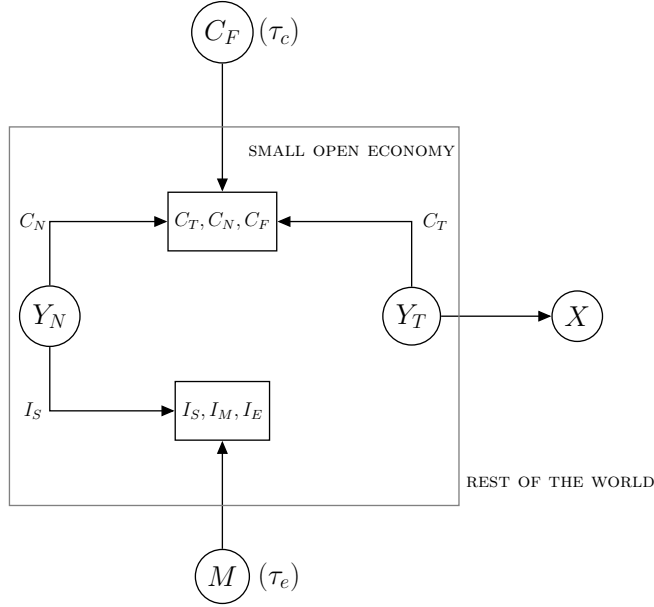

Figure 4.1: Diagram of the Economic Structure.

4.1.1 Firms

Production takes place in two sectors by a single representative firm. Namely, the tradable and non-tradable sectors. Each sector uses three factors of production. Non-tradable capital called *structures*, (S), tradable capital called *equipments* (E), and labor, (L). The economy domestically produces only nontraded capital, while importing the traded capital good that is subject to the investment tariff, τ_e .

The laws of motion for agent j 's holdings of structures and equipments are given by,

$$\dot{S}^j = I_S^j - \delta_S S^j \quad (4.1a)$$

$$\dot{E}^j = I_E^j - \delta_E E^j \quad (4.1b)$$

where δ_S and δ_E represent the depreciation rate of structures (nontraded capital) and equipments (traded capital), respectively.⁴

⁴Notice that we abstract from convex adjustment costs since they add an extra layer of dynamics, thereby augmenting the dynamics of the resulting equilibrium system, and not necessarily providing further insight about the relationship between tariff reductions and inequality. Of course, one may wish to introduce such costs as a realistic aspect of the investment process, however, the general qualitative conclusions will not change significantly.

The traded sector produces good Y_T (taken to be the numéraire) using structures (S_T), equipments (E_T), and labor (L_T) by means of a neoclassical production function,

$$Y_T = F(S_T, E_T, L_T) \quad (4.2)$$

Similarly, the nontraded sector is described by,

$$Y_N = H(S_N, E_N, L_N) \quad (4.3)$$

Structures, equipments and labor can move freely between the two sectors, with sectoral allocations being only constrained by,

$$S_T + S_N = S \quad (4.4a)$$

$$E_T + E_N = E \quad (4.4b)$$

$$L_T + L_N = 1 \quad (4.4c)$$

The relative price, p , is defined as nontraded output in terms of traded output, hence serving as a proxy for the real exchange rate.⁵ The representative firm makes its productive decisions to maximize profits, so that the wage rate, w , and the returns to the different types of capital, satisfy the following efficiency conditions,

$$w \equiv F_L(S_T, E_T, L_T) = pH_L(S_N, E_N, L_N) \quad (4.5a)$$

$$r_s \equiv F_S(S_T, E_T, L_T) = pH_S(S_N, E_N, L_N) \quad (4.5b)$$

$$r_e \equiv F_E(S_T, E_T, L_T) = pH_E(S_N, E_N, L_N) \quad (4.5c)$$

4.1.2 Households

The economy is populated by a mass one of infinitely-lived consumers, indexed by j , who are identical in all respects except for their initial endowments of structures, $S^j(0)$, equipments, $E^j(0)$, and internationally traded bonds, $B^j(0)$. In this

⁵An increase in p represents a real appreciation.

respect, we should note that while there are many sources of heterogeneity,⁶ initial endowments are arguably the most significant.⁷ Since we are interested in the behavior of the distribution, we shall focus on household j 's relative holdings of capital and bonds, $s^j \equiv S^j(t)/S(t)$, $e^j \equiv E^j(t)/E(t)$ and $b^j \equiv B^j(t)/B(t)$, where $S(t)$, $E(t)$, and $B(t)$ denotes the economy-wide average stock of structures, equipments and bonds, respectively. Initial relative endowments, $s^j(0)$, $e^j(0)$, $b^j(0)$ have mean one and relative standard deviations, $\sigma_s(0)$, $\sigma_e(0)$, $\sigma_b(0)$ across agents.⁸ Each agent is also endowed with one unit of time that he can allocate to labor in the traded sector, L_T^j , or in the nontraded sector, L_N^j . The agent supplies his labor inelastically. Hence, $L_T^j + L_N^j = 1$. With a continuum of agents, the economy-wide average supply of labor in each sector is given by $L_z = \int_0^1 L_z^j dj$ for all $z \in \{T, N\}$ and other aggregates are defined analogously.

Each consumer j has lifetime utility that depends upon the domestically produced traded good, C_T^j , the domestically produced nontraded good, C_N^j , and the imported consumption good, C_F^j , that is subject to a tariff, τ_c . All households have identical preferences described by the utility function

$$U_j = \int_0^{+\infty} \frac{1}{\gamma} \left[(C_T^j)^\theta (C_N^j)^{(1-\theta)} (C_F^j)^\eta \right]^\gamma e^{-\beta t} dt \quad (4.6)$$

$$0 \leq \theta \leq 1, 0 < \eta, -\infty < \gamma \leq 1, \theta\gamma < 1, \eta\gamma < 1$$

where $1/(1 - \gamma)$ is the consumer's intertemporal elasticity of substitution, θ measures the relative importance of the traded versus nontraded consumption good, η parameterizes the relative importance of the imported consumption good, and β is the subjective discount rate. The remaining restrictions in (4.6) ensure concavity of the utility function in the three consumption goods.

⁶Other sources of heterogeneity are skills, preferences, and financial constraints. See [Aiyagari \(1994\)](#), [Krusell and Smith \(1998\)](#) and [Fajgelbaum et al. \(2011\)](#).

⁷Compelling evidence supporting this view is provided by [Piketty \(2011\)](#), [Piketty and Goldhammer \(2014\)](#) and [Stiglitz \(2013\)](#).

⁸These initial endowments can be perfectly arbitrary and therefore consistent with any required non-negativity constraints. As will become apparent in the course of the analysis, the form of the distribution of the initial endowments will be reflected in the evolving distributions of wealth and income.

We assume that the consumer chooses his rates of consumption, C_T^j, C_N^j, C_F^j , and rates of accumulation of structures, $S^j(t)$, equipments, $E^j(t)$, and internationally traded bonds, $B^j(t)$, so as to maximize (4.6) subject to his instantaneous budget constraint. We *normalize* the price of the imported consumption good to equal the *unitary price* of the traded consumption good. In addition, the price of the imported capital good is normalized to equal the unitary price of the imported consumption good. Consequently, the budget constraint in terms of the domestically produced tradable good is given by,

$$\dot{B}^j = w + r_s S^j + r_e E^j + i \left(\frac{B}{pS} \right) B^j + T^j - C_T^j - p C_N^j - p I_S^j - (1 + \tau_c) C_F^j - (1 + \tau_e) I_E^j \quad (4.7)$$

Equation (4.7) shows that the consumer earns income from supplying labor in each sector, renting both types of capital, the interest earned on his holdings of internationally traded bonds, and from a lump-sum transfer made by the government, T^j . The excess of income over his consumption and investment expenditures is accumulated in the form of structures, equipments, and foreign bonds. The consumption expenditure side is given by the spending on the traded and nontraded consumption goods, and the imported consumption good inclusive of the tariff, τ_c . Furthermore, we assume that both tariffs can evolve gradually, hence they may be a function of time as defined below in equation (4.15).

The constraint in (4.7) corresponds to a lender or a borrower according to whether $B^j > 0$ or $D^j = -B^j > 0$, respectively. The equilibrium outcome depends upon the relative magnitudes of the time rate of preference and the given world interest rate, i^* . In either case a key element of the model is that while the economy has access to the **international capital market**, it faces frictions in the form of an upward-sloping supply curve of debt,⁹ expressed by the relationships,

⁹To break the knife-edge condition or achieve stationarity of the equilibrium dynamics, we have four alternatives: Uzawa-type preferences, upward-sloping supply curve of debt, cost of holding foreign bonds, the use of an overlapping generations (OLG) model, or including a demographic structure in the model (see [Oxborrow and Turnovsky \(2015\)](#)). We choose the second one because the implications are similar, but aggregation is simpler. For details on these modifications of the standard small open economy model; see [Turnovsky \(1985\)](#), [Turnovsky \(1997\)](#), [Turnovsky \(2002\)](#) and [Schmitt-Grohé and Uribe \(2003\)](#).

$$i\left(\frac{B}{pS}\right) = i^* - \omega\left(\frac{B}{pS}\right), \quad \omega(0) = 0, \omega' > 0, \omega'' > 0 \quad (4.8a)$$

$$i\left(\frac{D}{pS}\right) = i^* + \omega\left(\frac{D}{pS}\right), \quad \omega(0) = 0, \omega' > 0, \omega'' > 0 \quad (4.8b)$$

Equations (4.8) specify the friction between the lending/borrowing country and the international bonds market. Notice that the stock of structures (nontraded capital) introduces a wedge between the world interest rate, i^* , and the interest rate faced by the nation. This form to model the interest rate faced by a nation allows us to control for the level of development of the country. There are alternative ways to do this, but the qualitative implications will not change.¹⁰ The shape of the function $\omega(\cdot)$ reflects the degree of openness of the economy with respect to the financial market.

The household maximizes lifetime utility, (4.6), subject to his budget constraint, (4.7). The optimality conditions for his problem are given by,

$$\theta (C_T^j)^{\theta\gamma-1} (C_N^j)^{(1-\theta)\gamma} (C_F^j)^{\eta\gamma} = \lambda_j \quad (4.9a)$$

$$(1-\theta) (C_T^j)^{\theta\gamma} (C_N^j)^{(1-\theta)\gamma-1} (C_F^j)^{\eta\gamma} = p\lambda_j \quad (4.9b)$$

$$\eta (C_T^j)^{\theta\gamma} (C_N^j)^{(1-\theta)\gamma} (C_F^j)^{\eta\gamma-1} = (1+\tau_c)\lambda_j \quad (4.9c)$$

$$i\left(\frac{B}{pS}\right) = \beta - \frac{\dot{\lambda}_j}{\lambda_j} \quad (4.9d)$$

$$\frac{r_s}{p} - \delta_S + \frac{\dot{p}}{p} = \beta - \frac{\dot{\lambda}_j}{\lambda_j} \quad (4.9e)$$

$$\frac{r_e}{(1+\tau_e)} - \delta_E + \frac{\dot{\tau}_e}{(1+\tau_e)} = \beta - \frac{\dot{\lambda}_j}{\lambda_j} \quad (4.9f)$$

In addition, the following transversality conditions hold,

$$\lim_{t \rightarrow \infty} \lambda_j B^j e^{-\beta t} = \lim_{t \rightarrow \infty} \lambda_j p S^j e^{-\beta t} = \lim_{t \rightarrow \infty} \lambda_j E^j e^{-\beta t} = 0 \quad (4.10)$$

ensuring that the agent's intertemporal budget constraint is met.

¹⁰We could model the upward-sloping curve of debt in many different ways. It could depend upon structures and equipments, or output levels, or only equipments or even upon exports. These could lead to more complicated mathematics, but the insight should not change since many of these choices are a function of the stock of structures. Thus, we choose the simplest mathematical specification that provides more straightforward relations.

To reduce the number of relations associated with consumption goods, we divide (4.9c) by (4.9a) and (4.9b) by (4.9a) yielding to,

$$\theta(1 + \tau_c)C_F^j = \eta C_T^j \quad (4.11a)$$

$$(1 - \theta)C_T^j = \theta p C_N^j \quad (4.11b)$$

We define agent j 's total consumption expenditure in terms of the traded good, inclusive of the tariff, τ_c , as

$$C^j = C_T^j + p C_N^j + (1 + \tau_c)C_F^j \quad (4.12)$$

Thus, combining equations (4.11) and (4.12) yields to,

$$C_T^j = \left(\frac{\theta}{1 + \eta} \right) C^j; \quad p C_N^j = \left(\frac{1 - \theta}{1 + \eta} \right) C^j; \quad (1 + \tau_c)C_F^j = \left(\frac{\eta}{1 + \eta} \right) C^j \quad (4.13)$$

This implies that each individual consumes the three consumption goods in the same proportions.

Before proceeding to determine the law of motion for aggregate consumption, consider that in practice, programs of trade liberalization, and more specifically tariff reductions, are likely to involve extensive periods of negotiation and therefore may be implemented gradually over time.¹¹ To allow for this, we assume that the tariff rates are adjusted gradually from its initial rate, $\tau_{c,0}, \tau_{e,0}$, to its post liberalization rate, $\tilde{\tau}_c, \tilde{\tau}_e$, in accordance with the *known* path,

$$\tau_z(t) = \tilde{\tau}_z + (\tau_{z,0} - \tilde{\tau}_z)e^{-\nu_z t} \quad \forall z \in \{c, e\} \quad (4.14)$$

or equivalently,

$$\dot{\tau}_z(t) = -\nu_z(\tau_z(t) - \tilde{\tau}_z) \quad \forall z \in \{c, e\} \quad (4.15)$$

The parameter, ν_z , defines the speed at which the tariff rate changes and hence the time path it follows. The conventional assumption where the tariff rate is fully

¹¹For instance, the Trans-Pacific Partnership (TPP) Trade Agreement started to be discussed in 2008 and only in October 2015 an agreement was reached. Nevertheless, this agreement still needs approval in each Congress of the 12 member countries. Once this happens, it is very likely that the removal of tariffs will be implemented in stages.

adjusted at once is obtained by letting $\nu_z \rightarrow \infty$ in (4.14).¹² But the more general specification here introduced is important. This is because, as we will show in our numerical simulations, there is a remarkable contrast between how ν_z affects the dynamics of the *aggregate quantities* and of *distributions* across agents. As one would expect, the time path of tariffs affects the transitional path of the aggregate economy, but not the aggregate steady state. Yet, it influences both the time paths and the steady-state levels of both wealth and income inequality, thereby having permanent distributional effects.¹³

Taking the time derivatives of equations (4.13), we obtain,

$$\frac{\dot{C}_T^j}{C_T^j} = \frac{\dot{C}^j}{C^j} \quad (4.16a)$$

$$\frac{\dot{C}_N^j}{C_N^j} = \frac{\dot{C}^j}{C^j} - \frac{\dot{p}}{p} \quad (4.16b)$$

$$\frac{\dot{C}_F^j}{C_F^j} = \frac{\dot{C}^j}{C^j} - \frac{\dot{\tau}_c}{1 + \tau_c} \quad (4.16c)$$

Next, we take the time derivative of (4.9a),

$$(\theta\gamma - 1)\frac{\dot{C}_T^j}{C_T^j} + (1 - \theta)\gamma\frac{\dot{C}_N^j}{C_N^j} + \eta\gamma\frac{\dot{C}_F^j}{C_F^j} = \frac{\dot{\lambda}_j}{\lambda_j} \quad (4.17)$$

and combining (4.17) with (4.16), and using (4.9d) with (4.9e), we obtain

$$\frac{\dot{C}_T^j}{C_T^j} = \frac{\dot{C}^j}{C^j} = \frac{1}{1 - \gamma(1 + \eta)} \left[(1 - \theta)\gamma \left(\frac{r_s}{p} - \delta_S \right) + [1 - (1 - \theta)\gamma] i \left(\frac{B}{pS} \right) - \beta - \eta\gamma \frac{\dot{\tau}_c}{1 + \tau_c} \right] \quad (4.18a)$$

$$\frac{\dot{C}_N^j}{C_N^j} = \frac{1}{1 - \gamma(1 + \eta)} \left[[1 - \gamma(\theta + \eta)] \left(\frac{r_s}{p} - \delta_S \right) + \gamma(\theta + \eta) i \left(\frac{B}{pS} \right) - \beta - \eta\gamma \frac{\dot{\tau}_c}{1 + \tau_c} \right] \quad (4.18b)$$

$$\frac{\dot{C}_F^j}{C_F^j} = \frac{1}{1 - \gamma(1 + \eta)} \left[(1 - \theta)\gamma \left(\frac{r_s}{p} - \delta_S \right) + [1 - (1 - \theta)\gamma] i \left(\frac{B}{pS} \right) - \beta - (1 - \gamma) \frac{\dot{\tau}_c}{1 + \tau_c} \right] \quad (4.18c)$$

¹²The assumption that the change in the tariff rate occurs at a constant proportionate rate, and is completed only asymptotically, is made purely for analytical convenience. It is simple to generalize (4.14) to the case where the new level of the tariff is reached in finite time. The analysis could be modified to allow for the reduction in the tariff to follow a more general time path, and the same general qualitative implications would emerge, as long as the time path for the tariff is monotonic.

¹³The reason for this is the homogeneity of the utility function (4.6) which causes individuals to maintain fixed relative consumption over time. This introduces a “zero root” into the dynamics of the distributional measures, as a result of which *hysteresis* is observed.

Equations (4.18) imply that each individual chooses the same growth rate for the three consumption goods, and overall consumption.¹⁴ Thus,

$$\frac{\dot{C}_T}{C_T} = \frac{\dot{C}_T^j}{C_T^j} = \frac{\dot{C}^j}{C^j} = \frac{\dot{C}}{C}; \quad \frac{\dot{C}_N}{C_N} = \frac{\dot{C}_N^j}{C_N^j}; \quad \frac{\dot{C}_F}{C_F} = \frac{\dot{C}_F^j}{C_F^j} \quad \forall j \quad (4.19)$$

We may then write $C^j = \varphi_j C$, where $\int_0^1 \varphi_j dj = 1$, and φ_j is constant for each j , and yet to be determined. Thus defined, φ_j denotes individual j 's total consumption relative to the economy-wide average gross consumption expenditure.

4.1.3 The Government

We abstract from government spending on consumption or public capital as well as foreign transfers. To isolate the distributional impacts of tariffs, we assume that the domestic government rebates tariff revenues to households in the form of a lump-sum transfer. It issues no debt and maintains a balanced budget in accordance with,

$$T(t) = \tau_c C_F + \tau_e I_E \quad (4.20)$$

Equation (4.20) is expressed in terms of the traded good that is consistent with the budget constraint given in (4.7). We further assume that tariff revenues are rebated uniformly across agents,¹⁵ so that $T^j(t) = T(t)$, for each j .

4.2 Macroeconomic Equilibrium

Because of the linearity of the optimality conditions in quantities pertaining to the individuals, aggregation is simple to perform. Thus, summing over (4.13), we can

¹⁴The right-hand side of equations (4.18) is common to all individuals since it is independent of j . Hence the growth rate of these quantities is the same for all agents, but not necessarily the level of the same.

¹⁵Another assumption that would also isolate the redistributive role of the tariffs would be to assume that the tariff revenues are allocated to government expenditure which has no impact on private behavior. Otherwise, if we were to assume that tariff revenues are spent on some activity that enhances private productivity, we would have the difficulty of disentangling the effect of the tariff from the productive effect of the expenditure. Hence, understanding this first case is essential to address the one just mentioned.

express the equilibrium aggregate economy-wide consumption levels, $C_T(t)$, $C_N(t)$, $C_F(t)$ in terms of the total consumption expenditure, the relative price, the consumption tariffs and other micro-founded parameters,

$$C_T = \left(\frac{\theta}{1 + \eta} \right) C \quad (4.21a)$$

$$C_N = \left(\frac{1 - \theta}{1 + \eta} \right) \frac{C}{p} \quad (4.21b)$$

$$C_F = \frac{\eta}{(1 + \eta)(1 + \tau_c)} C \quad (4.21c)$$

Next, combining equation (4.18a) with (4.19), we may write the equilibrium dynamics of aggregate consumption as,

$$\dot{C} = \frac{C}{1 - \gamma(1 + \eta)} \left[(1 - \theta)\gamma \left(\frac{r_s}{p} - \delta_S \right) + [1 - (1 - \theta)\gamma] i \left(\frac{B}{pS} \right) - \beta - \eta\gamma \frac{\dot{\tau}_c}{1 + \tau_c} \right] \quad (4.22)$$

We see that consumption depends upon the time path of the tariff levied on the imported consumption good. Hence, a particular time path for the change in τ_c will have transitional effects on the time path of consumption. This in turn affects the dynamics of the whole economic system as it will be shown later.

In addition, nontraded goods market clearing implies that nontraded output in excess of total domestic consumption and investment is accumulated as structures subtracting what needs to be replaced due to depreciation. Thus, the law of motion for structures is described by

$$\dot{S} = H(S_N, E_N, L_N) - C_N - \delta_S S \quad (4.23)$$

while the law of motion for equipments is given by equation (4.1b).

We now turn to the current account relationship. Given the linearity of equation (4.7), we can easily aggregate it over all individuals. Using the market clearing condition for the nontraded sector written as in (4.23) and the government budget constraint, (4.20), we obtain

$$\dot{B} = F(S_T, E_T, L_T) + i \left(\frac{B}{pS} \right) B - C_T - C_F - I_E \quad (4.24)$$

Last, the law of motion for the relative price is obtained by combining the optimality conditions related to bond holdings and structures given by (4.9d) and

(4.9e), respectively. Straightforward algebraic manipulation yields to,

$$\dot{p} = p \left[i \left(\frac{B}{pS} \right) + \delta_S - \frac{r_s}{p} \right] \quad (4.25)$$

The linear homogeneity of the production function allows us to express the relations in intensive form. Defining $s_z \equiv S_z/L_z$ to be the structures-labor ratio in sector $z \in \{T, N\}$. The sectoral equipment-labor ratio, e_z , is analogously defined. Thus,

$$Y_T = F(S_T, E_T, L_T) \equiv f(s_T, e_T)L_T, \quad Y_N = H(S_N, E_N, L_N) \equiv h(s_N, e_N)L_N \quad (4.26)$$

Adopting this notation, we may rewrite the rates of return given by (4.5), the optimality conditions in (4.9) and the relations in (4.21), in terms of sectoral allocations. These static relationships of the macroeconomic equilibrium are summarized as follows,

$$f_s(s_T, e_T) = ph_s(s_N, e_N) \quad (4.27a)$$

$$f_e(s_T, e_T) = \left[i \left(\frac{B}{pS} \right) + \delta_E \right] (1 + \tau_e) + \nu_e(\tau_e - \tilde{\tau}_e) \quad (4.27b)$$

$$ph_e(s_N, e_N) = \left[i \left(\frac{B}{pS} \right) + \delta_E \right] (1 + \tau_e) + \nu_e(\tau_e - \tilde{\tau}_e) \quad (4.27c)$$

$$f(s_T, e_T) - s_T f_s(s_T, e_T) - e_T f_e(s_T, e_T) = p [h(s_N, e_N) - s_N h_s(s_N, e_N) - e_N h_e(s_N, e_N)] \quad (4.27d)$$

$$S = L_T s_T + (1 - L_T) s_N \quad (4.27e)$$

$$E = L_T e_T + (1 - L_T) e_N \quad (4.27f)$$

where $\tilde{\tau}_e$ represents the steady-state value for the tariff on the imported investment good. Hereafter, tildes will denote steady-state values.

Next, we rewrite the law of motion for structures, equipments, bonds, the relative price and consumption in terms of sectoral allocations. These are given

by,

$$\dot{S} = (1 - L_T)h(s_N, e_N) - \left(\frac{1 - \theta}{1 + \eta}\right) \frac{C}{p} - \delta_S S \quad (4.28a)$$

$$\dot{E} = I_E - \delta_E E \quad (4.28b)$$

$$\dot{B} = L_T f(s_T, e_T) + i \left(\frac{B}{pS}\right) B - \frac{(\theta + \theta\tau_c + \eta)}{(1 + \eta)(1 + \tau_c)} C - I_E \quad (4.28c)$$

$$\dot{p} = p \left[i \left(\frac{B}{pS}\right) + \delta_S - h_s(s_N, e_N) \right] \quad (4.28d)$$

$$\dot{C} = \frac{C}{1 - \gamma(1 + \eta)} \left[(1 - \theta)\gamma (h_s(s_N, e_N) - \delta_S) + [1 - (1 - \theta)\gamma] i \left(\frac{B}{pS}\right) - \beta + \eta\gamma\nu_c \left(\frac{\tau_c - \tilde{\tau}_c}{1 + \tau_c}\right) \right] \quad (4.28e)$$

This system of differential equations can be further reduced. First, consider equations (4.27a) to (4.27d). We observe that the explicit choice function (ECF) for the sectoral allocations are given by,

$$s_T = s_T(p, S, B; \tau_e) \quad ; \quad e_T = e_T(p, S, B; \tau_e) \quad (4.29a)$$

$$s_N = s_N(p, S, B; \tau_e) \quad ; \quad e_N = e_N(p, S, B; \tau_e) \quad (4.29b)$$

Next, using the market clearing condition for structures in its sectoral form, we may write,

$$L_T = \frac{S - s_N(p, S, B; \tau_e)}{s_T(p, S, B; \tau_e) - s_N(p, S, B; \tau_e)} \equiv L_T(p, S, B; \tau_e) \quad (4.30)$$

Similarly, the market clearing condition for equipments yields to,

$$E = L_T(p, S, B; \tau_e)e_T(p, S, B; \tau_e) + (1 - L_T(p, S, B; \tau_e))e_N(p, S, B; \tau_e) \equiv E(p, S, B; \tau_e) \quad (4.31)$$

Let us reduce the dynamical system by combining equations (4.28b) and (4.28c),

$$\dot{B} = L_T f(s_T, e_T) + i \left(\frac{B}{pS}\right) B - \frac{(\theta + \theta\tau_c + \eta)}{(1 + \eta)(1 + \tau_c)} C - \dot{E} - \delta_E E \quad (4.32)$$

We also know from equation (4.31) that,

$$\dot{E} = \frac{\partial E}{\partial p} \dot{p} + \frac{\partial E}{\partial S} \dot{S} + \frac{\partial E}{\partial B} \dot{B} + \frac{\partial E}{\partial \tau_e} \dot{\tau}_e \quad (4.33)$$

Equation (4.33) into (4.32) yields to,

$$\dot{B} = L_T f(s_T, e_T) + i \left(\frac{B}{pS}\right) B - \frac{(\theta + \theta\tau_c + \eta)}{(1 + \eta)(1 + \tau_c)} C - \frac{\partial E}{\partial p} \dot{p} - \frac{\partial E}{\partial S} \dot{S} - \frac{\partial E}{\partial B} \dot{B} - \frac{\partial E}{\partial \tau_e} \dot{\tau}_e - \delta_E E \quad (4.34)$$

This can be rearranged as,

$$\left(1 + \frac{\partial E}{\partial B}\right) \dot{B} = L_T f(s_T, e_T) + i \left(\frac{B}{pS}\right) B - \frac{(\theta + \theta\tau_c + \eta)}{(1 + \eta)(1 + \tau_c)} C - \frac{\partial E}{\partial p} \dot{p} - \frac{\partial E}{\partial S} \dot{S} - \frac{\partial E}{\partial \tau_e} \dot{\tau}_e - \delta_E E \quad (4.35)$$

Details are in the appendix. Here, we summarize the basic procedure. Consider equations (4.27a) to (4.27f). Then, totally differentiate equations (4.27a) to (4.27d). By doing so, you obtain all the partial derivatives of the sectoral allocations with respect to p , S , B , and τ_e . To obtain the partial derivatives of equipments with respect to p , S , B , and τ_e , we also need to know the partial derivatives of labor allocated to the traded sector which are obtained using the market clearing condition for structures. Therefore, combining the partial derivatives of sectoral allocations with the partial derivatives of labor allocated to the traded sector, we can then write the partial derivatives of equipments as explicit functions of the variables involved. This procedure allows us to linearize the dynamical system around the steady state.

Therefore, the dynamical system is now given by equations (4.28a), (4.35), (4.28d), (4.28e), and (4.15).

4.2.1 Steady State

The steady-state equilibrium is attained by setting $\dot{p} = \dot{S} = \dot{E} = \dot{B} = \dot{C} = \dot{\tau}_c = \dot{\tau}_e = 0$ and is summarized as follows. First, the sectoral allocation relationships are given by,

$$f_e(\tilde{s}_T, \tilde{e}_T) = (1 + \tilde{\tau}_e)(\beta + \delta_E) \quad (4.36a)$$

$$\tilde{p}h_e(\tilde{s}_N, \tilde{e}_N) = (1 + \tilde{\tau}_e)(\beta + \delta_E) \quad (4.36b)$$

$$f_s(\tilde{s}_T, \tilde{e}_T) = \tilde{p}h_s(\tilde{s}_N, \tilde{e}_N) \quad (4.36c)$$

$$f(\tilde{s}_T, \tilde{e}_T) - \tilde{s}_T f_s(\tilde{s}_T, \tilde{e}_T) - \tilde{e}_T f_e(\tilde{s}_T, \tilde{e}_T) = \tilde{p} [h(\tilde{s}_N, \tilde{e}_N) - \tilde{s}_N h_s(\tilde{s}_N, \tilde{e}_N) - \tilde{e}_N h_e(\tilde{s}_N, \tilde{e}_N)] \quad (4.36d)$$

$$h_s(\tilde{s}_N, \tilde{e}_N) - \delta_S = \beta \quad (4.36e)$$

Equations (4.36a) to (4.36d) are optimality conditions, and (4.36e) corresponds to $\dot{p} = 0$. We can see that the steady-state levels are independent of the time path of tariffs but not from the investment tariff steady-state value. These 5 equations

are not sufficient to determine the steady state. Hence, we also use the aggregate market-clearing relationships given by,

$$\tilde{S} = \tilde{L}_T \tilde{s}_T + (1 - \tilde{L}_T) \tilde{s}_N \quad (4.37a)$$

$$\tilde{E} = \tilde{L}_T \tilde{e}_T + (1 - \tilde{L}_T) \tilde{e}_N \quad (4.37b)$$

$$(1 - \tilde{L}_T)h(\tilde{s}_N, \tilde{e}_N) = \left(\frac{1 - \theta}{1 + \eta}\right) \frac{\tilde{C}}{\tilde{p}} + \delta_S \tilde{S} \quad (4.37c)$$

$$\tilde{L}_T f(\tilde{s}_T, \tilde{e}_T) + \beta \tilde{B} = \frac{\theta + \theta \tilde{\tau}_c + \eta}{(1 + \eta)(1 + \tilde{\tau}_c)} \tilde{C} + \delta_E \tilde{E} \quad (4.37d)$$

$$i \left(\frac{\tilde{B}}{\tilde{p} \tilde{S}} \right) = \beta \quad (4.37e)$$

Equations (4.37a) and (4.37b) are market clearing conditions for structures and equipments, respectively. Equation (4.37c) is obtained from $\dot{S} = 0$, while (4.37d) is obtained using $\dot{B} = \dot{E} = 0$. Last, (4.37e) corresponds to $\dot{C} = 0$

Thus, we have 10 unknowns and 10 equations. Using equations (4.36a) to (4.36e) and (4.37a) to (4.37e), we determine the steady-state values (denoted by tildes) $\{\tilde{s}_T, \tilde{e}_T, \tilde{s}_N, \tilde{e}_N, \tilde{L}_T, \tilde{p}, \tilde{S}, \tilde{B}, \tilde{E}, \tilde{C}\}$ and with equations (4.21) we can obtain $\{\tilde{C}_T, \tilde{C}_N, \tilde{C}_F\}$.

4.2.2 Transitional Dynamics

In Section 4.4.2 below we shall analyze the local dynamics following a decrease in the tariff rates, (τ_c and/or τ_e), by linearizing equations (4.28a), (4.35), (4.28d), (4.28e), and (4.15) about their steady state (4.36)-(4.37). The formal structure of this system is set out in Appendix C.2, where the unique stable adjustment path is characterized. There it is strongly suggested that the system exhibits saddlepath behavior in the neighborhood of the steady state.¹⁶ Given the specified trajectory for tariffs that may or may not evolve sluggishly, depending upon ν_z , describes a two-dimensional stable manifold, along which structures, and foreign bonds evolve

¹⁶It is possible by examining the characteristic equation of the dynamic system to derive the formal condition. However, such exercise is not only very tedious, but also not very illuminating. Hence, we rely on our simulation results to establish the plausibility of this desired root configuration.

gradually, while the relative price and consumption may respond instantaneously to new information as it comes available.

4.3 Wealth and Income Inequality

4.3.1 Wealth Inequality

To abstract from any direct, but arbitrary, discretionary distributional effects arising from lump-sum transfers, we assume that tariff revenues are rebated uniformly across agents, namely, $T_j(t) = T(t)$. The tax-adjusted wealth of agent i , measured in terms of domestic output is defined by,

$$V^j = pS^j + (1 + \tau_e)E^j + B^j \quad (4.38)$$

where we assume that $V^j > 0$ so that the agent has net positive wealth and is therefore solvent. Taking the time derivative of (4.38), and using the arbitrage conditions (4.9e), (4.9f), and the budget constraint of agent j , (4.7), we obtain,

$$\dot{V}^j = i \left(\frac{B}{pS} \right) V^j + w(t) + T - C^j \quad (4.39)$$

Summing (4.38) over all agents,

$$\dot{V} = i \left(\frac{B}{pS} \right) V + w(t) + T - C \quad (4.40)$$

Next, we define individual j 's share of aggregate wealth to be $v_j \equiv V^j/V$. Taking the time derivative of v_j , and combining (4.38) and (4.40), together with the fact that $C^j = \varphi_j C$, we may write,

$$\dot{v}_j(t) = \frac{1}{V} \left[(C(t) - w(t) - T(t)) (v_j - 1) + (1 - \varphi_j) C(t) \right] \quad (4.41)$$

Equation (4.41) shows how the evolution of an individual agent's relative adjusted wealth depends upon the evolution of aggregate gross consumption expenditure, the real wage rate and his own specific endowments as reflected in v_j and φ_j .

Before linearizing (4.41) around the steady state and solving for it, we consider the steady-state values coming from (4.40). From the law of motion for aggregate

wealth we obtain,

$$\tilde{C} = \beta\tilde{V} + \tilde{w} + \tilde{T} \quad (4.42)$$

Equation (4.42) shows that aggregate steady-state consumption equals the income from tax-adjusted wealth, wage income, and the tariff revenue. Moreover, (4.42) implies that $\tilde{C} > \beta\tilde{V}$, hence the average long-run propensity to consume out of wealth exceeds β , implying that poorer agents consume proportionately more and save proportionately less.

Equation (4.41) at the steady state combined with the previous result in (4.42) yields to,

$$\beta\tilde{V}(\tilde{v}_j - 1) = -(1 - \varphi_j)\tilde{C} \quad (4.43)$$

This can be rewritten as,

$$\tilde{C}^j - \tilde{C} = \beta\tilde{V}(\tilde{v}_j - 1) = \beta(\tilde{V}^j - \tilde{V}) \quad (4.44)$$

Thus if, for instance, agent j 's wealth places him above the average, his long-run marginal propensity to consume out of the above-average component of his wealth is β . We also see that with a uniform wage, in the long run relatively poor people work more and enjoy less leisure such that they can keep their consumption.

From equation (4.43) we obtain,

$$\varphi_j = \left(\frac{\beta\tilde{V}}{\tilde{C}} \right) (\tilde{v}_j - 1) + 1 \quad (4.45)$$

To analyze the evolution of relative wealth, we linearize (4.41) in a neighborhood of the steady state. Omitting details, the linearized equation becomes (see Appendix C.3),¹⁷

$$\dot{v}_j(t) = \beta(v_j(t) - \tilde{v}_j) - (\tilde{v}_j - 1) \cdot \langle \mathbf{R}, (\mathbf{x} - \tilde{\mathbf{x}}) \rangle \quad (4.46)$$

where \mathbf{R} is a column vector formed by $R_k(\tilde{p}, \tilde{B}, \tilde{S}, \tilde{C}, \tilde{\tau}_e) \equiv \left. \frac{\partial \tilde{v}_j}{\partial x_k} \right|_{SS}$, $\mathbf{x} = (p, B, S, C, \tau_e)^T$ and $\langle \cdot, \cdot \rangle$ represents the inner product operator. The key feature of equation (4.46)

¹⁷The procedure we follow is developed in greater detail in [Turnovsky and García-Peñalosa \(2008\)](#)

is that the coefficient of $v_j(t) > 0$. Hence, for the long-run distribution of wealth to be non-degenerate, each agent's relative wealth must remain finite. To achieve this requires that the solution for $v_j(t)$ is given by the forward-looking solution,

$$v_j(t)-1 = (\tilde{v}_j-1) \left[1 + \sum_{x \in \Omega} \left(\frac{\Gamma_x}{\tilde{V}} \int_t^\infty (x(u) - \tilde{x}) e^{-\beta(u-t)} du \right) \right] \quad \Omega = \{p, B, S, C, \tau_c, \tau_e\} \quad (4.47)$$

where for notational convenience,

$$\chi(t) = \left[1 + \sum_{x \in \Omega} \left(\frac{\Gamma_x}{\tilde{V}} \int_t^\infty (x(u) - \tilde{x}) e^{-\beta(u-t)} du \right) \right] \quad \Omega = \{p, B, S, C, \tau_c, \tau_e\}$$

where,

$$\begin{aligned} \Gamma_x &= \left. \frac{\partial w}{\partial x} \right|_{SS} + \tilde{\tau}_e \left. \frac{\partial \dot{E}}{\partial x} \right|_{SS} + \tilde{\tau}_e \delta_E \left. \frac{\partial E}{\partial x} \right|_{SS} \quad \forall x \in p, B, S \\ \Gamma_{\tau_c} &= \left(\frac{\eta}{1 + \eta} \right) \frac{\tilde{C}}{(1 + \tilde{\tau}_c)^2} \\ \Gamma_{\tau_e} &= \left. \frac{\partial w}{\partial \tau_e} \right|_{SS} + \tilde{\tau}_e \left. \frac{\partial \dot{E}}{\partial \tau_e} \right|_{SS} + \tilde{\tau}_e \delta_E \left. \frac{\partial E}{\partial \tau_e} \right|_{SS} + \delta_E \tilde{E} \\ \Gamma_C &= - \frac{\tilde{\tau}_e \delta_E \tilde{E} + \tilde{w}}{\tilde{C}} \end{aligned}$$

Hence, we can write,

$$v_j(t) - 1 = \chi(t)(\tilde{v}_j - 1) \quad (4.48)$$

Because of the linearity of equation (4.47) across agents which describes a specific individual's relative asset position, we can directly derive a measure of relative wealth inequality by applying the standard deviation operator. This yields,

$$\sigma_v(t) = \chi(t) \tilde{\sigma}_v \quad (4.49a)$$

$$\sigma_v(0) = \chi(0) \tilde{\sigma}_v \quad (4.49b)$$

Thus, given $\sigma_v(0)$, we can determine the entire time path of $\sigma_v(t)$. Furthermore, we assume that initially all agents hold the same portfolio shares. That is, $S_{j,0}/S_{k,0} = E_{j,0}/E_{k,0} = B_{j,0}/B_{k,0}$ for all j, k .

4.3.2 Income Inequality

The income measure we consider is taken to include labor income, interest earned on wealth (composed by structures, equipments and internationally traded bonds), and the transfers received from the tariff revenues. Using the arbitrage conditions, agent j 's income is given by,

$$M^j(t) = i(t)V^j(t) + w(t) + T(t) \quad (4.50)$$

with aggregate income being,

$$M(t) = i(t)V(t) + w(t) + T(t) \quad (4.51)$$

so that the agent's relative income, $m_j(t) \equiv M^j(t)/M(t)$, is

$$m_j(t) - 1 \equiv \frac{M^j(t)}{M(t)} - 1 = \frac{i(t)V(t)}{i(t)V(t) + w(t) + T(t)}(v_j(t) - 1) \quad (4.52)$$

Again, because of the linearity of (4.52), we can express the relationship between relative income and relative wealth in terms of the corresponding standard deviations of their respective distributions, $\sigma_v(t)$ and $\sigma_m(t)$, namely,

$$\sigma_m(t) = \frac{i(t)V(t)}{i(t)V(t) + w(t) + T(t)}\sigma_v(t) \equiv \zeta(t)\sigma_v(t) \quad (4.53)$$

where $\zeta(t) \equiv i(t)V(t)/[i(t)V(t) + w(t) + T(t)]$ denotes the share of income from wealth in total personal income. Hence, at any instant of time income inequality can be decomposed into the product of wealth inequality multiplied by the income from net wealth as a share of total income, $\zeta(t)$. The time path of income inequality reflects that of wealth inequality and the share of income from wealth,

$$\frac{\dot{\sigma}_m(t)}{\sigma_m(t)} = \frac{\dot{\zeta}(t)}{\zeta(t)} + \frac{\dot{\sigma}_v(t)}{\sigma_v(t)} = \left[\frac{di/dt}{i(t)} + \frac{\dot{V}(t)}{V(t)} - \left(\frac{\dot{w}(t) + \dot{T}(t)}{w(t) + T(t)} \right) \right] \frac{w(t) + T(t)}{i(t)V(t) + w(t) + T(t)} + \frac{\dot{\sigma}_v(t)}{\sigma_v(t)} \quad (4.54)$$

Assuming that the economy starts out in an initial steady state, (4.53) reduces to,

$$\tilde{\sigma}_{m,0} = \frac{\beta\tilde{V}_0}{\beta\tilde{V}_0 + \tilde{w}_0 + \tilde{T}_0}\tilde{\sigma}_{v,0} \quad (4.55)$$

and dividing (4.53) by (4.55), we derive the following expression for income inequality relative to the initial long-run inequality,

$$\frac{\sigma_m(t)}{\tilde{\sigma}_{m,0}} = \zeta(t) \left(\frac{\beta\tilde{V}_0 + \tilde{w}_0 + \tilde{T}_0}{\beta\tilde{V}_0} \right) \frac{\sigma_v(t)}{\tilde{\sigma}_{v,0}} \quad (4.56)$$

In steady state (4.56) combined with (4.42) simplifies to,

$$\frac{\tilde{\sigma}_m}{\tilde{\sigma}_{m,0}} = \left(\frac{\tilde{C}_0/\tilde{V}_0}{\tilde{C}/\tilde{V}} \right) \frac{\tilde{\sigma}_v}{\tilde{\sigma}_{v,0}} \quad (4.57)$$

so that long-run income inequality varies positively with long-run changes in wealth inequality and inversely with changes in the gross consumption-wealth ratio.

4.4 Numerical Analysis

Because of the complexity of the model, analyzing the consequences of a reduction in tariffs on the dynamics of wealth and income inequality as well as the aggregate economy requires the use of numerical simulations. These are based on the utility function, (4.6), and the following Cobb-Douglas production functions,¹⁸

$$Y_T = A_T(S_T)^\alpha(E_T)^\varepsilon(L_T)^{1-\alpha-\varepsilon} \quad (4.58a)$$

$$Y_N = A_N(S_N)^\rho(E_N)^\phi(L_N)^{1-\rho-\phi} \quad (4.58b)$$

where α and ρ characterize the respective degree of nontraded capital (structures) intensity in the two sectors, and ε and ϕ characterize the respective degree of traded capital (equipments) intensity in the two sectors. The production functions expressed in sectoral form can be written as,

$$\frac{Y_T}{L_T} = f(s_T, e_T) = A_T(s_T)^\alpha(e_T)^\varepsilon \quad (4.59a)$$

$$\frac{Y_N}{L_N} = f(s_N, e_N) = A_N(s_N)^\rho(e_N)^\phi \quad (4.59b)$$

In addition, the lending or borrowing constraints are defined by,

$$i = i^* - \xi [e^{a(B/pS)} - 1] \quad (4.60a)$$

$$i = i^* + \xi [e^{a(D/pS)} - 1] \quad (4.60b)$$

¹⁸Extending the numerical analysis to use a constant elasticity of substitution (CES) production function is straightforward.

The parameters used to calibrate the benchmark economy are discussed in the next section and summarized in Table 4.1.

4.4.1 Calibration

The dynamics of two-sector models of this type depends upon the relative sectoral capital intensities, which in turn have an important bearing on the dynamics of the real exchange rate. Furthermore, in our model we have two relative capital intensities, namely, structures and equipment intensities. This makes the analysis more complex compared to models in which sectors differ only in a unique type of capital. Thus, there is little consensus as to what the appropriate specification of this aspect should be. This has been extensively discussed in the literature associated with the dependent-economy model. [Brock and Turnovsky \(1994\)](#) provide a precise and concise description of this point. We therefore can potentially contrast multiple cases. For this chapter, we investigate the following example.

Table 4.1: The Benchmark Economy (Example)

Parameter values	
Preference parameters	$\beta = 0.06, \theta = 0.4, \gamma = -1.5, \eta = 0.35$
Production parameter	$\alpha = 0.10, \varepsilon = 0.20, \rho = 0.20, \phi = 0.10$
Productivity parameter	$A_N = A_T = 1.0$
Depreciation rates	$\delta_S = 0.08, \delta_E = 0.10$
World interest rate	$i^* = 0.03$
Premium on borrowing	$a = 0.10$
Weight on the premium	$\xi = 1.0$
Tariffs	$\tau_c=0.10, \tau_e=0.10, \nu_c = 0.10, \nu_e = 0.10$

We interpret this case as a plausible benchmark for emerging countries that are mainly exporters of raw materials such as Chile, Colombia, Ecuador, Gabon,

Ghana, Iraq, Sudan and many others.¹⁹

4.4.2 Quantitative Experiments

Tables 4.2 and 4.3 show the steady-state equilibrium responses for the case in which the traded sector is equipments intensive ($\alpha < \rho$) and the nontraded sector is structures intensive ($\rho > \phi$). We observe that investment tariff reductions have larger effects on economic activity than consumption tariff reductions. This is an expected result since the *structure* of the economy explicitly depends upon the tariff on equipments, but not upon the consumption tariffs. The dynamics of the economy depends upon the consumption tariffs, but not its structure. This outcome is also intuitive since capital taxes are more distortionary than consumption taxes. See Ramsey (1927) and Lucas (1990).

We observe that a consumption tariff reduction increases output in the tradable sector, while it reduces production in the nontradable one. This obeys to the fact that the imported consumption good becomes relatively cheaper and hence, consumers move away from the nontradable consumption good. Instead, if the tariff on equipments is reduced, both sectors increase their output. This happens because both sectors use equipments and given the tariff reduction, its price become relatively cheaper. Furthermore, either type of tariff reduction augment wealth in this economy. Thus, with the right mix of redistributive policies, everyone could eventually benefit.

Table 4.3 shows the long-run distributional consequences of tariff liberalization. The first point to highlight is that the effects can be either positive or negative, and their magnitudes is relatively significant. This is aligned with the empirical literature. See Jaumotte et al. (2013) and Roj. We observe that a liberalization on consumption tariffs alleviates both wealth and income inequality.

¹⁹According to The CIA World Factbook approximately 70% of the countries in the world could be classified as being mainly exporters of raw materials.

Table 4.2: Case I: Steady-state equilibrium economic-activity responses.

A. Debtor Country: $\beta = 0.06$, $i^* = 0.03$, Elimination Consumption Tariff.								
	\tilde{S}	\tilde{E}	\tilde{L}_T	\tilde{V}	\tilde{p}	\tilde{C}	\tilde{Y}_T	\tilde{Y}_N
Benchmark case:								
$\alpha = 0.10$, $\eta = 0.35$								
Initial eq. ($\tau_c = 0.10$)	1.019	0.901	0.599	1.682	0.975	0.717	0.475	0.327
Eliminate tariff ($\tau_c = 0$)	1.013	0.906	0.607	1.683	0.975	0.700	0.481	0.320
% Change	(-0.57)	(+0.49)	(+1.30)	(+0.06)	(0.00)	(-2.38)	(+1.30)	(-2.01)
B. Debtor Country: $\beta = 0.06$, $i^* = 0.03$, Elimination Investment Tariff.								
	\tilde{S}	\tilde{E}	\tilde{L}_T	\tilde{V}	\tilde{p}	\tilde{C}	\tilde{Y}_T	\tilde{Y}_N
Benchmark case:								
$\alpha = 0.10$, $\eta = 0.35$								
Initial eq. ($\tau_e = 0.10$)	1.019	0.901	0.599	1.682	0.975	0.717	0.475	0.327
Eliminate tariff ($\tau_e = 0$)	1.032	1.019	0.602	1.726	0.985	0.729	0.490	0.329
% Change	(+1.28)	(+13.10)	(+0.56)	(+2.63)	(+1.06)	(+1.59)	(+3.18)	(+0.68)

Consumption Tariff

Figure 4.2 shows the transitional dynamics of the main macroeconomic variables in response to a reduction of the consumption tariff from 10% to 0%. The main driving forces behind these impulse response functions are the return on capital and forward-looking expectations. For details see [Rojas-Vallejos and Turnovsky \(2015\)](#).

Investment Tariff

Figure 4.3 shows the transitional dynamics of the main macroeconomic variables in response to a reduction of the investment tariff from 10% to 0%. In this case,

Table 4.3: Case I: Steady-state equilibrium inequality responses.

A. Debtor Country: $\beta = 0.06$, $i^* = 0.03$, Elimination Consumption Tariff.				
	$\tilde{\sigma}_v$		$\tilde{\sigma}_m$	
	Discrete $\Delta\tau_c$	Gradual $\Delta\tau_c$	Discrete $\Delta\tau_c$	Gradual $\Delta\tau_c$
Benchmark case: $\alpha = 0.10$, $\eta = 0.35$				
Initial equilibrium ($\tau_c = 0.10$)	1.000	1.000	0.123	0.123
Eliminate tariff ($\tau_c = 0$)	0.989	0.992	0.115	0.115
% Change	(-1.10)	(-0.84)	(-6.76)	(-6.49)
B. Debtor Country: $\beta = 0.06$, $i^* = 0.03$, Elimination Investment Tariff.				
	$\tilde{\sigma}_v$		$\tilde{\sigma}_m$	
	Discrete $\Delta\tau_e$	Gradual $\Delta\tau_e$	Discrete $\Delta\tau_e$	Gradual $\Delta\tau_e$
Benchmark case: $\alpha = 0.10$, $\eta = 0.35$				
Initial equilibrium ($\tau_e = 0.10$)	1.000	1.000	0.123	0.123
Eliminate tariff ($\tau_e = 0$)	1.035	0.970	0.129	0.120
% Change	(+3.52)	(-3.04)	(+4.71)	(-1.93)

the real depreciation that happens when the economy is liberalized leads quickly to a higher stock of structures and equipments. This implies to a lower return on these types of capital. Wages also deteriorate initially but slower than the returns on capital. Therefore, there is an initial reduction on income inequality. Over time, however, returns on capital dominate the effect from wages and income inequality starts rising.

Figure 4.2: Debtor Nation ($i^* > \beta$). Elimination of *consumption tariff* from 10%.

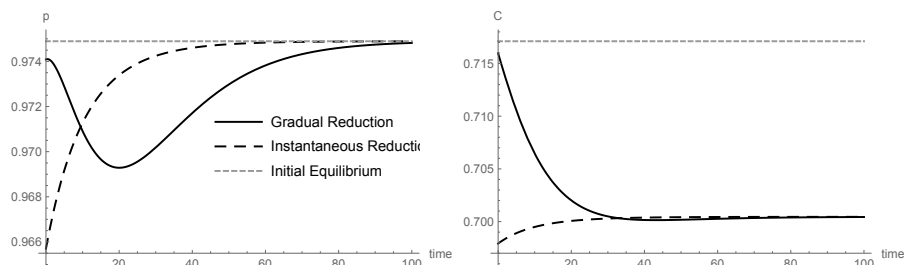

(a) Relative Price

(b) Gross Consumption Expenditure

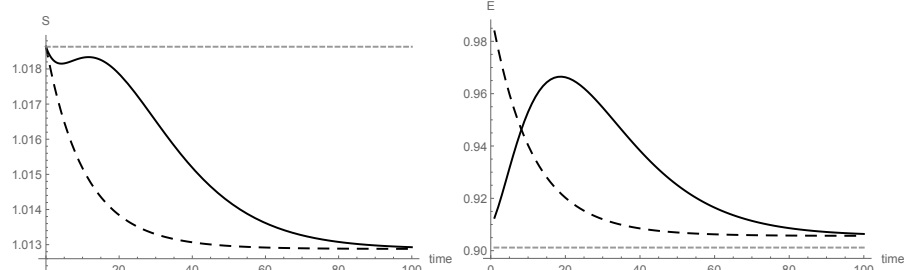

(c) Structures

(d) Equipments

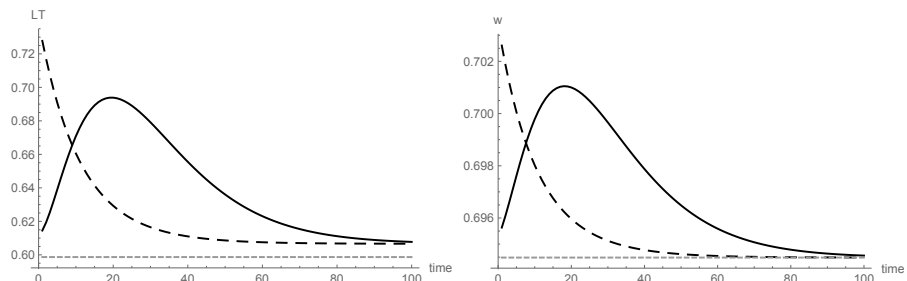

(e) Labor Supply Tradable Sector

(f) Wages

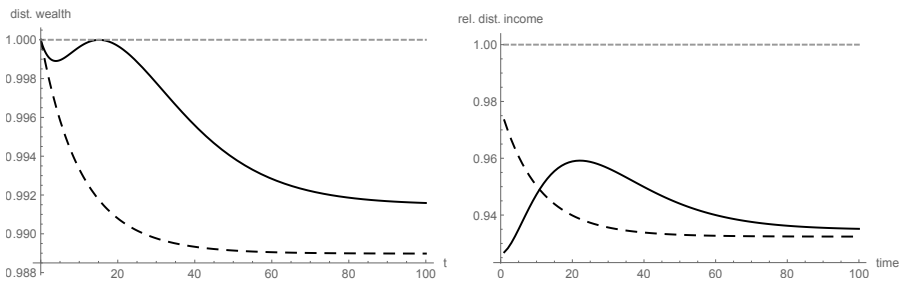

(g) Wealth Inequality

(h) Income Inequality

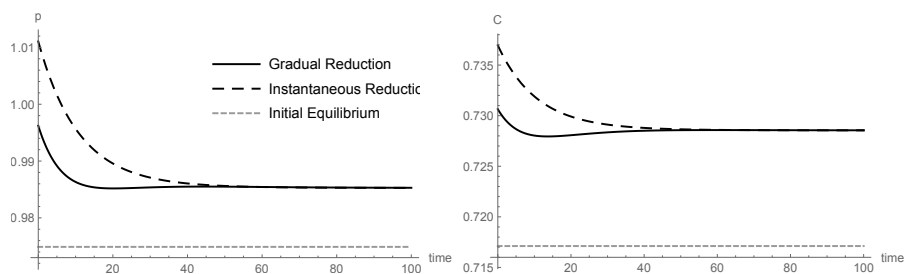
Figure 4.3: Creditor Nation ($i^* > \beta$). Elimination of *investment tariff* from 10%.

(a) Relative Price

(b) Gross Consumption Expenditure

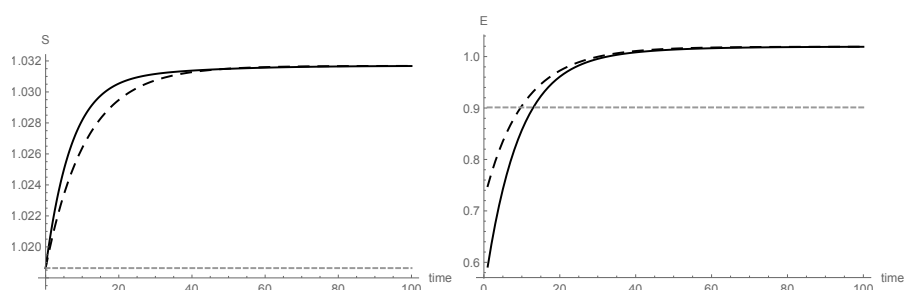

(c) Structures

(d) Equipments

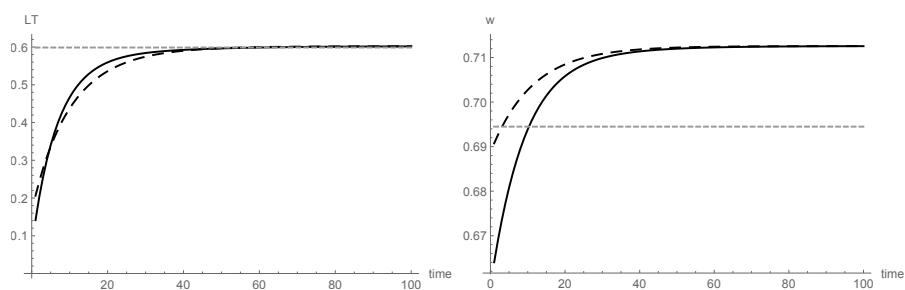

(e) Labor Supply Tradable Sector

(f) Wages

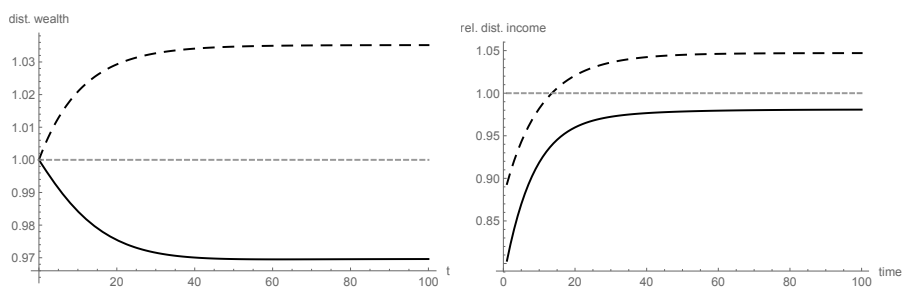

(g) Wealth Inequality

(h) Income Inequality

4.5 Conclusions

Despite the predictions of the mainstream theory on international trade that relies on the Heckscher-Ohlin framework, it is quite debatable to state that more trade liberalization is always good for developing countries. Many empirical studies have shown contradicting results to the Heckscher-Ohlin model that states that more trade liberalization should reduce income inequality in developing countries, while increasing it in advanced ones. In this paper, we propose an alternative setting that reconciles theory and empirics. Furthermore, we show that the complexities of a general dependent-economy model that abstracts from nominal rigidities and the political system is sufficient to highlight the arguably main force behind inequality. That is, the returns on capital holdings.

Our model also reconciles the view on the expansionary effects of tariff liberalization with the increase of within-country income inequality observed in most of the world, more especially on developing economies. To some extent this theory supports the arguments given by [Kuznets \(1955\)](#) about early stages of development as is the case of emerging economies. Kuznets claims that this type of economies will experience higher inequality as they get richer.

Further research on this topic should include an intensive data collection task to verify and quantify the causal effect we argue in this paper.

Chapter 5

THE “NEED TO BELONG” IN SEARCH BY COMMITTEE

Casual empiricism suggests that individuals feel good when their input into an aggregate decision is heeded not just heard. Recounting the times when our own recommendations as referees were echoed in the editorial decisions and comparing those to times when they were not, or recalling participation in faculty recruitment committees and their eventual decisions adds to this view. Formally, psychologists mark an innate emotional need to belong to a group as an essential part of being human. Indeed, the “belongingness theory of motivation”, pioneered by [Baumeister and Leary \(1995\)](#), is a key area of basic research in Social Psychology with important clinical applications. It also has interdisciplinary influences that range from applied Management Science to Sociology.¹ There is also some recent neurobiological evidence that vindicates the emotional need to belong. See for example [Dunbar \(2006\)](#), [Eisenberger et al. \(2003\)](#) and [Eisenberger and Cole \(2012\)](#).

In Economics, despite a well known proclamation by Adam Smith (1759) that people derive a special pleasure of mutual sympathy from belonging to groups, formal models have come to include this need relatively recently. George Akerlof and Rachel Kranton argue in a series of papers that being able to identify with a group is an important part of an agents well-being. See for example, [Akerlof](#)

¹Although the human need to form interpersonal contacts is asserted at least since Freud, the most widely cited hierarchy of human needs is due to Albert Maslow (See [Maslow \(1943\)](#) and [Maslow \(1968\)](#)). In this, love and belongingness needs rank in the middle of the hierarchy. [Baumeister and Leary \(1995\)](#) are the first to provide systematic empirical validation of this speculative ranking. Also see [Ryan and Deci \(2000\)](#) and the references therein. Although Maslow’s original hierarchy has seen several revisions, it continues to be important in popular media and among management gurus. See for example Abraham Maslow and the pyramid that beguiled business. BBC news magazine, William Kremer; Hammond, Claudia (31 August 2013) or the TED talk Measuring what makes life worthwhile by Chip Conley, hotelier and Airbnb head of hospitality.

and Kranton (2000) or Akerlof and Kranton (2005). Heap and Zizzo (2009) is an empirical study that lends support to their thesis. There is also a small literature in Political Science where members of a jury are accorded a preference winning, which may be identified with the need to belong. See for example Callander (2008), Callander (2007) and the references therein.

Thus motivated, this paper studies the implications of incorporating a “need to belong” within the preferences of members voting in committees. We do this by postulating that a committee member’s need to belong is met only if the alternative she has voted for is also the committees eventual choice. In every such instance, the member derives a positive utility in addition to any intrinsic utility benefit she receives from the committees’ chosen alternative. We show how the presence of even an infinitesimal “need to belong” among committee members can significantly alter the equilibrium behavior in interesting ways.

More precisely, we reconsider the problem of sequential search to be undertaken by a committee, as posited in Albrecht et al. (2010). (Also see Compte and Jehiel (2010)). There, at each instant, a candidate is presented to a committee consisting of some N members. Each member, having privately and independently observed the random value of the candidate being presented in the current period, votes either in favor of selecting the candidate or continuing the search. Search stops if M ($\leq N$) vote to do so. Otherwise, at the cost of a one period delay, the committee samples another candidate and the process repeats. AAV demonstrate the existence of a unique (interior) symmetric Markov equilibrium - there is time invariant acceptance threshold on the candidates value and a member votes to stop the search in any period only if the value she draws is above that threshold. They then present a number of interesting comparative statics on how this threshold and the corresponding expected search duration varies as committee size or the size of the majority change.

We parametrically introduce the need to belong in the above model by assuming that a member receives a flow utility of $\alpha > 0$ in any period when she votes for the search to continue (stop) and the search indeed continues (stops) in that pe-

riod. This is in addition to the value of the candidate should the search stop. The parameter α measures a member's need to belong to the group. Our interest is primarily in the case where $\alpha \approx 0$ to emphasize that the psychological/behavioral variation we introduce is of second-order to the standard model. After all, the model is simply the AAV's committee search model if $\alpha = 0$. A key question is whether the presence of a need to belong raises or lowers the equilibrium acceptance threshold.

We show that the presence of a non-zero α leads to *multiple interior* equilibria in the committee search game. Proposition 2, Section 3 shows there are now three types of equilibria, in sharp contrast to the uniqueness result in AAV. There are those referred to as *regular equilibria*, namely equilibria that are close to the original AAV equilibrium. There also exist *conformal equilibria*, which are equilibria in which with probability close to one, players unanimously vote to continue the search in every period or unanimously vote to stop for the search. Thus, if the equilibrium with the lowest acceptance threshold is selected, which we refer to as a *left extreme equilibrium*, the conclusion would be that the presence of a need to belong lowers the acceptance threshold making the committee less picky and simply hires the first candidate that is presented with a high probability. On the other hand, if one chooses the equilibrium with the largest acceptance threshold, *right extreme equilibrium*, one is led to the opposite conclusion, with a high probability of that the search continues indefinitely. The existence of these extreme equilibria also prevent us from carrying out comparative statics exercises with respect to size of the majority. For that, we prove Proposition 3, Section 3 to show that for α sufficiently small, for any (M, N) pair there is a left extreme equilibrium that cannot be compared with the right extreme equilibrium of any other (M', N) pair.

To understand the seemingly anomalous behavior, note that player's vote in any period matters only in the event that she is pivotal. In a Markov strategy profile with a sufficiently low acceptance threshold, this probability is small, although positive. Moreover the continuation probability is low. By voting to stop the search then, a typical player secures α with a high probability. On the other

hand, the probability of being pivotal is still positive. Hence, if the signal she receives on the current candidate is sufficiently low, she still has an incentive to vote to continue the search instead. Trading these off, one can find an acceptance threshold low enough which is also the pivotal type that is indifferent between voting to continue the search and to stop and thus an equilibrium. A symmetric argument also ensures an equilibrium with a very high acceptance threshold, one in which search continues with a very high probability. When the need to belong is positive, at such acceptance thresholds then, the game reduces to a “beauty contest” - virtually every type is interested in mimicking others behavior².

To obtain sharper predictions, in Section 3.2 we apply the Pareto principle to select from the multiple equilibria. This section contains Proposition 4, which shows that if the unique equilibrium threshold of the AAV model occurs above the product of the mean value of the candidate and the discount factor, an intermediate equilibrium is a Pareto superior equilibrium. Otherwise, a left extreme equilibrium is Pareto superior. In case of the latter, the presence of a need to belong to a group clearly causes the acceptance threshold to fall. In case of the former, the proposition also offers a sufficient condition whereby for simple and supermajority rules (i.e. for $M \geq (N + 1)/2$), the presence of the need to belong raises the acceptance threshold.

5.1 *Related Literature*

There is of course a vast literature on strategic voting in committees. Some of the more prominent ones include Feddersen and Pesendorfer (1998), Austen-Smith and Banks (1996), Persico (2004), Ottaviani and Sørensen (2001) and Levy (2007). Some of the models in this literature incorporate career concerns and reputation in members preferences. Callander (2007) and Callander (2008) in particular, extends the Austen-Smith and Banks (1996) to include (in addition to the value of

²In the AAV model, there are two corner equilibria in addition to the unique interior equilibrium. In these, the acceptance threshold is either the lower end of the support, whereby all types vote for the search to stop, or the upper end where all types vote for the search to continue at all nodes. As $\alpha \rightarrow 0$ and the need to belong disappears, the extreme equilibria of our model converge to the two corresponding corner equilibria.

the candidate) a preference for winning in two party elections. The preference for winning is isomorphic to the need to belong being considered in this paper. He finds the emergence of multiple equilibria with poor aggregation of information. In Levy (2007), there are career concerns, and just as in the literature on herd behavior (see Bikhchandani et al. (1998) and the references therein), members discount their prior information and equilibria display certain conformal behavior. It is important to note that all of these are models primarily with a focus on aggregation information in common-value settings or with correlated information. Interestingly, conformal behavior appears here is a typical independent private values framework where information aggregation is a non-issue. As such, it illustrates the importance of the assumed innate need to belong to a group, other things being equal.

Decision making in committees is sometimes modeled as a voting game and at other times as a bargaining game. Voting models may be interpreted as bargaining games which limit the ability of the members to make a counteroffer. Compte and Jehiel (2010) is fairly general treatment of search in such games and embeds the analysis of AAV. In the main, the two papers differ on the nature of questions being asked, the former focuses on the agreement set as players become patient, whereas the latter on studies comparative statics with respect to (M, N) . Moldovanu and Shi (2013) study a variant of AAV in which members have different specialties and they put more weight on their specialty to vote for a candidate. One would expect the inclusion of a need to belong in these more general models to yield qualitatively similar results to the ones presented here³.

Finally, it is important to distinguish conformal equilibria that appear in this paper with the literature on conformity in Economics that follows the notable contributions by Bernheim (1994) and Lindbeck (1997). In such models, there is an exogenously specified norm. An agent of a given type suffers a utility loss if her type-dependent optimal action differs from the norm. Pooling equilibria where

³Moldovanu and Shi (2013) primarily study unanimity rules. It should become clear that under unanimity, one would expect only the introduction of only a right extreme equilibrium.

agents of different types take the same action, with the cost of signaling dictated by the assumed norm, is interpreted as conformity. In contrast, in this paper, there is no pre-specified norm. (In fact, the equilibrium itself is the endogenous norm.) Instead, the psychological need is directly incorporated into the utility function and constant across player types. In this sense, this paper follows the research agenda set out in the series of papers by George Akerlof and Rachel Kranton cited earlier. Thus, we contribute to this literature by looking at the impact of committee decision making when incorporating some of the psychological aspects they suggest.

The rest of this paper is organized as follows. Section 5.2 contains the main model and the main results from AAV that are needed for the analysis here. Section 5.3 characterizes the equilibria of the AAV model upon including the sense of belonging. Section 5.3.2 studies Pareto efficient equilibria. Section 5.4 concludes. Proofs of all the propositions and other technical details not included in the body of the paper are in Appendix D.

5.2 *The Model*

We begin by recalling the committee search problem from AAV. At each discrete moment $t = 1, 2, \dots$, unless the search has concluded, a committee consisting of N members is presented with a candidate. In each period that the search is still active, every member receives an instantaneous utility that is normalized to zero whereas if the search ends at date t , the instantaneous utility member of i is x_{it} . The latter is a random draw from a continuous, log concave probability distribution F with $[0, 1]$ as its support. Unless the search has terminated, members privately observe their respective values for the candidate presented in the current period, and vote via a secret ballot on whether the search should continue. Search continues unless at least $M(\leq N)$ members vote to stop. All committee members discount the future by a factor $\delta \in (0, 1)$.

Let f denote the corresponding probability density. (It is implicit that values are drawn independently across time and across members).

We introduce one change to the above framework of AAV, namely that in addition to the value of the candidate, a member receives an instantaneous utility of $\alpha > 0$ in every period in which her vote coincides with the committee's eventual decision for that period. α measures the extent of a member's "need to belong" to a group that was discussed in the Introduction.

To describe the payoffs formally, denote a vote to stop or to continue in any period by 1 and 0 respectively. A ballot is then a vector $\mathbf{a} = (a_1, \dots, a_n) \in \{0, 1\}^n$. The corresponding instantaneous utility of member i if she votes to stop (i.e. $a_i = 1$) when others vote according to \mathbf{a}_{-i} is given by

$$u_i(1, \mathbf{a}_{-i}, x_i) = \begin{cases} x_i + \alpha & \text{if } \sum_{j \neq i} a_j \geq M - 1 \\ 0 & \text{if } \sum_{j \neq i} a_j \leq M - 2 \end{cases} \quad (5.1)$$

Similarly, if she votes for the search to continue (i.e. $a_i = 0$), the corresponding utility is

$$u_i(0, \mathbf{a}_{-i}, x_i) = \begin{cases} \alpha & \text{if } \sum_{j \neq i} a_j \leq M - 1 \\ x_i & \text{if } \sum_{j \neq i} a_j \geq M \end{cases} \quad (5.2)$$

We assume that α is common-knowledge. After all, the members interact repeatedly and presumably over a range of issues. Hence, arguably the degree to which a member values her role in the committee may have become common-knowledge. Moreover, this is an important first step to understanding the case where players are incompletely informed about α . As we elaborate later Section 5.4, such an extension warrants a separate analysis.

Certain other assumptions implicit in the model are without loss of generality. For instance, one may modify the model so that a member receives α_a if her vote is "accepted" by the committee while she receives α_r if her vote is rejected. The analysis to follow may be seen to be immune to such a modification provided $\alpha_a > \alpha_r$ by setting $\alpha := \alpha_h - \alpha_l$, i.e. α is the net benefit of being accepted. Further, the assumption that the support is $[0, 1]$ is also without loss of generality, any compact interval will do.

The above describes a multi-stage game with incomplete information, which we shall refer to as the committee search game (with parameters α, M, N). In this game, a member's strategy is a sequence of functions that map histories to $\{0, 1\}$, describing how the voting should occur in each period. One especially simple strategy is to pick an acceptance threshold, say $z \in (0, 1)$, and a player votes for the search to stop in any period t if and only if her value $x_{it} \geq z$. As such a strategy disregards information from the past periods, it will be called a Markov strategy with an acceptance threshold or a cutoff z ⁴.

Remark 5.1 (*Corner Equilibria*). *It is worth pointing out at the outset, that in this model, as in most voting models, there are equilibria in which no player is ever pivotal. When $M < N$, one may simply set the acceptance thresholds to either $y = 0$ or $y = 1$. In the former case where the acceptance threshold is 0, a player necessarily votes to stop at every node. Since no one player is then pivotal, voting to stop independent of any history or information is a mutual best response for all the players. Likewise, in a Markov strategy profile where no candidate is acceptable, i.e. $y = 1$, voting to continue at all nodes is a mutual best response. These are however not equilibria in undominated strategies. Just as AAV and much of the literature on voting, we too rule these out and focus only on Markov equilibria in which every player has a positive probability of being pivotal. Or equivalently, we look for Markov equilibria in which the acceptance threshold is in the interior of $[0, 1]$.*

To characterize symmetric interior Markov equilibria of the search game, i.e. a Bayes-Nash equilibrium in which every player chooses a Markov strategy with a common-acceptance threshold, we begin by choosing a cutoff $z \in (0, 1)$ and letting $p(z, k, n)$ and $Q(z, k, n)$ respectively denote the probability that exactly k and at least k of some n members draw a value above z . That is, for all $k \leq n \leq N$ and

⁴As stated in [Albrecht et al. \(2010\)](#), in the single-agent search, the Markovian assumption is without loss of generality. However, search by committee is a game, non-stationary strategies can potentially be supported as equilibria. In the current context, since our results concern the introduction of multiplicity to even the set of interior Markov equilibria, consideration of non-stationary equilibrium is arguably unimportant.

$z \in [0, 1]$,

$$p(z, k, n) = \binom{n}{k} (1 - F(z))^k F(z)^{n-k} \quad Q(z, k, n) = \sum_{j=k}^n p(z, j, n)$$

Then,

$$P(z, k, n) = 1 - Q(z, k, n)$$

denotes the probability that $k - 1$ or fewer of some n members draw a value above z .

To describe whether a symmetric Markov strategy profile with a given acceptance threshold can in fact be supported as an equilibrium, we shall apply the one-shot deviation principle. That is, we need only check whether a player has the incentives to vote as prescribed by the strategy profile at a given node having, fixed the behavior at all subsequent nodes by all players. Toward this end, let us pick an acceptance threshold $z \in (0, 1)$ for a Markov equilibrium and assume all the members play their part in this strategy profile. Let $V(z, \alpha)$ denote the corresponding ex-ante payoff of a typical member. We shall provide an explicit expression for $V(z, \alpha)$ presently. Let us now consider the incentives of an arbitrary player to vote for the search to continue, after drawing some value $x \in [0, 1]$ at a certain node.

Note that conditional on member i voting to stop the search, the search stops at that node with probability $Q(z, M - 1, N - 1)$ and continues with probability $P(z, M - 1, N - 1)$. Similarly, if member i were to vote to continue the search, the search stops at that node with probability $Q(z, M, N - 1)$ and continues with probability $P(z, M, N - 1)$. If the player votes for the search to stop, her (present value) at date t is $\delta^t U(1, x, z)$ where

$$U(1, x, z) = Q(z, M - 1, N - 1)(x + \alpha) + P(z, M - 1, N - 1)\delta V(z, \alpha)$$

Similarly, if she votes to continue the search, the present value is $\delta^t U(0, x, z)$ where

$$U(0, x, z) = Q(z, M, N - 1)x + P(z, M, N - 1)\alpha + P(z, M, N - 1)\delta V(z, \alpha)$$

Elementary algebraic manipulation gives us

$$\begin{aligned} U(1, x, z) - U(0, x, z) &= p(z, M - 1, N - 1)(x - \delta V(z, \alpha)) \\ &\quad + (Q(z, M - 1, N - 1) - P(z, M, N - 1))\alpha \end{aligned} \quad (5.3)$$

Let $x(z, \alpha)$ denote an interior type, if one exists, who is indifferent to voting for the search to continue and not. That is,

$$x(z, \alpha) = \varphi(z, M, N)\alpha + \delta V(z, \alpha, M, N) \quad (5.4)$$

is a solution in x to the equation $U(1, x, z) - U(0, x, z) = 0$, where

$$\varphi(z, M, N) = \frac{P(z, M, N - 1) - Q(z, M - 1, N - 1)}{p(z, M - 1, N - 1)} \quad (5.5)$$

Observe that the partial derivative of $U(1, x, z) - U(0, x, z)$ w.r.t. x is $p(z, M - 1, N - 1) > 0$. Therefore, there is a strict incentive for voting in favor of stopping the search if $x > x(z, \alpha)$ and a strict incentive to vote to continue if $x < x(z, \alpha)$. In other words, the set of types who prefer to vote to stop and those who prefer to vote to continue are separated into at most two sub-intervals with $x(z, \alpha)$ as the common boundary. Usual considerations that require an equilibrium to be self-enforcing, and an appeal to the one-shot deviation principle give us the following characterization: search game.

Lemma 5.1 *A Markov strategy profile with a common acceptance threshold $y \in (0, 1)$ is an (interior) equilibrium if and only if y is a fixed point of $x(\cdot, \alpha)$.*

Write $x_0(z) := x(z, 0)$ and $V_0(z) := V(z, 0)$. When $\alpha = 0$, we have the following characterization of the equilibrium of the search game, due to AAV.

Proposition 5.1 *(Albrecht, Anderson, Vroman, JET 2010). Suppose $\alpha = 0$. $x_0(\cdot)$ is a continuous function with $x_0(0) > 0$, $x_0(1) < 1$ and $x'_0(z) < 1$. Consequently, there exists a unique $y^* \in (0, 1)$ that is the acceptance threshold of an interior Markov Equilibrium.*

Figure 5.1 shows a typical plot of $x_0(z) - z$ and illustrates Proposition 5.1. The unique intersection with the horizontal axis, namely y^* is the acceptance threshold in the unique Markov equilibrium.

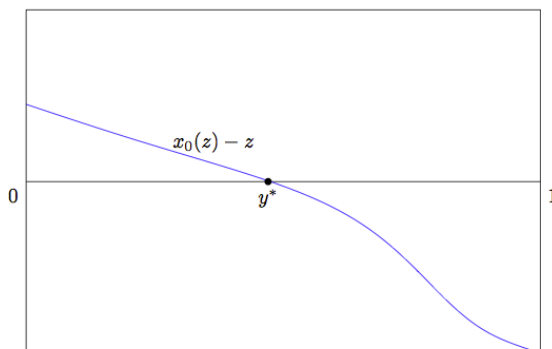

Figure 5.1: Plot of $x_0(z) - z$, as z varies between 0 and 1, for $M = 4$, $N = 7$, $\delta = 0.9$. y^* is the unique equilibrium.

5.3 Interior equilibria under the need to belong

We now turn to the case of $\alpha > 0$. To gain an intuitive understanding of how this affects the equilibrium set, let us begin by considering (5.3) with $\alpha = 0$ which, in this case, reduces to $p(z, M - 1, N - 1)(x - \delta V_0(z))$. Recall this is the difference in the payoff between choosing to vote to stop and to continue for a typical member of type x given that play at all other nodes is given by a Markov strategy with a candidate acceptance threshold of z . Such a type gets a payoff of x if the search stops and the discounted present value of $\delta V_0(z)$ if the search continues. Her vote on whether to continue to search or otherwise matters only when she is pivotal. Consequently, the difference in the payoff to the two actions is simply the probability that the member is pivotal, namely $p(z, M - 1, N - 1)$ multiplied by the $x - \delta V_0(z)$. Since $\delta V_0(z)$ is a constant, the pivotal type, (which is also the acceptance threshold) must be such that $\delta V_0(z) = z$. Proposition 5.1 effectively amounts to showing that the above equation has a unique solution.

Now suppose $\alpha > 0$ and let us reconsider (5.3) with an acceptance threshold $z \approx 0$ or $z \approx 1$. That is, now all the remaining members are respectively voting to stop the search with a probability close to one or continue with probability close to one. In either case, the probability that the agent is pivotal is close to zero. Therefore what primarily matters to an agent, independent of her type, is to bet on

the right action so that her action coincides with the committee's decision, allowing here to derive the utility α . The search stops with probability $Q(z, M - 1, N - 1)$ if she votes to stop. It continues with probability $P(z, M, N - 1)$ if she votes for it to continue. If $z \approx 0$, the former is higher whereas the latter is higher if the $z \approx 1$. Thus, for such acceptance levels, the game is primarily a beauty contest, each player seeks to match the actions of others. Analogously to the reasoning found in most coordination games, one may now surmise the existence of multiple equilibria.

Figure 5.2 is in fact a plot of $x(z, \alpha) - z$ for a positive α ($\alpha = 0.01$) with the remaining parameters as in Figure 5.1. As we see below, the presence of α distorts the original curve $x_0(z) - z$ so that the new curve has two vertical asymptotes at $z = 0$ and $z = 1$, the limit of the function being $-\infty$ at the former and $+\infty$ at the latter. Moreover, $x(z, \alpha)$ can be seen to converge to $x_0(z)$ pointwise for each $z \in (0, 1)$ as $\alpha \rightarrow 0$. It then follows that for α sufficiently small, there are at least three fixed points: y_l, y_m and y_r . Each of these constitute the acceptance thresholds in a Markov equilibrium. The analysis below will show that this situation is typical for any continuous prior distribution F and except in the case of unanimity (i.e. $M = N$).

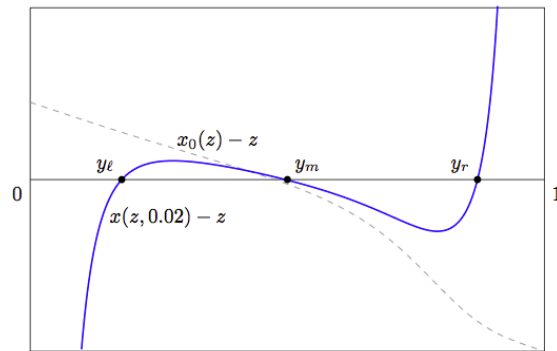

Figure 5.2: Plot of $x(z, \alpha) - z$, as z varies between 0 and 1, for $M = 4, N = 7, \delta = 0.9$ and $\alpha = 0.02$. y_l, y_m and y_r are all equilibrium acceptance threshold in a Markov equilibrium.

Definition 5.1 (*Regular and Conformal Equilibria*). Let $\varepsilon > 0$ be given. An interior Markov equilibrium is said to be a conformal equilibrium if its acceptance threshold lies in $(0, \varepsilon)$ or $(1 - \varepsilon, 1)$. A Markov equilibrium with an acceptance threshold in $(y^* - \varepsilon, y^* + \varepsilon)$ is said to be a regular equilibrium.

One should think of ε as being small. In a conformal equilibrium, the probability that the search continues from any given period to the next is no more than $P(\varepsilon, M, N)$ or no less than $P(1 - \varepsilon, M, N)$. That is, with a very high likelihood all players vote for the search to stop or continue respectively. The acceptance threshold in a regular equilibrium lies within a ε neighborhood of y^* and approximates the behavior in the AAV model (i.e. $\alpha = 0$ case). To show the existence of these equilibria we begin by deriving an explicit expression for $V(z, \alpha)$. Note that

$$\begin{aligned} V(z, \alpha) &= \int_0^z U(0, x, z) dF(x) + \int_z^1 U(1, x, z) dF(x) \\ &= F(z)Q(z, M, N - 1)\mu_l(z) + (1 - F(z))Q(z, M - 1, N - 1)\mu_h(z) \\ &\quad + (F(z)P(z, M, N - 1) + (1 - F(z))P(z, M - 1, N - 1))\delta V(z, \alpha) \\ &\quad + (F(z)P(z, M, N - 1) + (1 - F(z))Q(z, M - 1, N - 1))\alpha \end{aligned}$$

where, we have used the notation $\mu_l(z) = E[X|X \leq z]$ and $\mu_h(z) = E[X|X \geq z]$. We may solve for $V(z, \alpha)$ from the above and using the fact that $P(z, M, N)$ is equal to the expression $F(z)P(z, M, N - 1) + (1 - F(z))P(z, M - 1, N - 1)$ and introducing the notation

$$\omega(z) = \frac{F(z)Q(z, M, N - 1)}{1 - P(z, M, N)}$$

we have

$$V(z, \alpha) = \frac{(1 - P(z, M, N))}{1 - \delta P(z, M, N)} (\omega(z)\mu_l(z) + (1 - \omega(z))\mu_h(z)) + \psi(z)\alpha$$

where

$$\psi(z) = \frac{F(z)P(z, M, N - 1) + (1 - F(z))Q(z, M - 1, N - 1)}{1 - \delta P(z, M, N)} \quad (5.6)$$

Letting $V_0(z) := V(z, 0)$,

$$V(z, \alpha) = V_0(z) + \psi(z)\alpha \quad (5.7)$$

Combining this with (4), we get

$$x(z, \alpha) = x_0(z) + (\varphi(z) + \psi(z))\alpha \quad (5.8)$$

Fixed points of $x(\cdot, \alpha)$ (and only those) constitute the acceptance thresholds of Markov equilibria. When $\alpha > 0$, as evident from (5.8), we need to examine the properties of the functions $\psi(z)$ and $\varphi(z)$ to determine the fixed points of $x(\cdot, \alpha)$. We have the following lemma that isolates the main properties of $x(z, \alpha)$ to prove the existence of various types of equilibria.

Lemma 5.2 *$x(\cdot, \cdot)$ is continuous in both its arguments on $(0, 1) \times [0, \infty]$. Moreover, for any $\alpha > 0$, $\lim_{z \rightarrow 1} x(z, \alpha) = \infty$ and if $M \neq N$, $\lim_{z \rightarrow 0} x(z, \alpha) = -\infty$. If $M = N$, $\lim_{z \rightarrow 0} x(z, \alpha) = x_0(0)$.*

Proof. It is easy to see that ψ is non-negative. It is also bounded, since its denominator takes values in $(1 - \delta, 1)$ and the numerator takes values in $[0, 1]$. It is clearly continuous. Next, observe that the numerator of $\varphi(z)$ converges to -1 and 1 as z converges to 0 and 1, respectively. Using the fact that $\lim_{z \rightarrow 0} p(z, k, n) = \lim_{z \rightarrow 1} p(z, k, n) = 0$, provided $k \neq n$, we readily conclude that φ has two asymptotes at $z = 0$ and $z = 1$ with $\lim_{z \rightarrow 0} \varphi(z) = -\infty$ and $\lim_{z \rightarrow 1} \varphi(z) = \infty$. The fact that $x(z, \alpha)$ is linear in α and the foregoing arguments complete the proof of claim of its continuity as well as the existence of its asymptotes. If $k = n$, then $\lim_{z \rightarrow 0} p(z, n, n) = 1$ while $\lim_{z \rightarrow 0} p(z, n, n) = 0$, which accounts for the $M = N$ case. \square

The Lemma helps us in describing all the interior Markov equilibria of the game.

Definition 5.2 (*Extreme Equilibria*). *Let $\varepsilon > 0$ be given. The Markov equilibrium with the lowest acceptance threshold, say y_l is said to be the left-extreme equilibrium if it is also conformal, i.e. $0 < y_l < \varepsilon$. A right-extreme equilibrium, denoted by y_r is defined analogously.*

Proposition 5.2 *For any $\varepsilon > 0$, there exists $\alpha_\varepsilon > 0$ such that for all $\alpha \in (0, \alpha_\varepsilon)$ the following holds:*

1. *A left-extreme, a right-extreme and a regular equilibrium exist.*
2. *Moreover, every equilibrium is either a conformal equilibrium or a regular equilibrium.*

Proofs of all the propositions are in Appendix D.

Proposition 5.2 stands in sharp contrast to Proposition 5.1. Even for arbitrarily small but non-zero values of α , the committee search problem exhibits *multiple interior* equilibria. Moreover, the predicting behavior varies greatly depending on which equilibrium one selects.

5.3.1 *The need to belong and search duration*

How does the need to belong impact on the expected search duration? From Proposition 5.2 we learn that this depends on which equilibrium one selects, but for a fixed committee size. The next proposition isolates properties on the variation of these equilibria with respect to α that will allow us to draw conclusions across committee sizes.

Proposition 5.3 *Suppose $M < N$. Choose any $\varepsilon > 0$ and let α_ε be as given in Proposition 5.2. For $\alpha \in (0, \alpha_\varepsilon)$,*

1. *The acceptance threshold of the left extreme equilibrium is increasing in α .*
2. *The acceptance threshold of the right extreme equilibrium is decreasing in α .*

The above proposition is illustrated in Figure 5.3.

In other words, the acceptance thresholds of the “most conformal” equilibria get pushed out toward 0 and 1 as α gets closer to zero. Observe that the probability that the search stops within a given period in a left-extreme equilibrium is at least $Q(\varepsilon, M, N)$ whereas that probability in a right-extreme equilibrium is at most

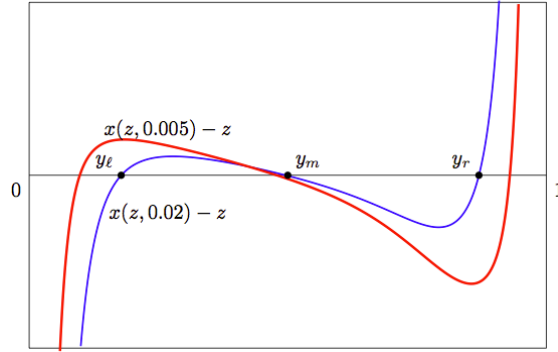

Figure 5.3: The red curve is a plot of $x(z, \alpha)$ as the value of α falls relative to that of the blue curve. The leftmost and the rightmost intersections are seen to move to the respective endpoints, as claimed in Proposition 5.3

$Q(1 - \varepsilon, M, N)$. Since $\lim_{\varepsilon \rightarrow 0} Q(\varepsilon, M, N) = 1$ and $\lim_{\varepsilon \rightarrow 0} Q(1 - \varepsilon, M, N) = 0$ for $M \neq N$, it follows that we can find ε^* sufficiently small such that

$$Q(\varepsilon^*, M, N) > Q(1 - \varepsilon^*, M', N) \quad \forall M, M' < N$$

Similar conclusions also hold for the expected search duration, which is given by the expression $(1 - P(z, M, N))^{-1}$ in a Markov equilibrium with an acceptance threshold z . Depending on which extreme equilibrium one chooses to focus on, the search ends or continues with probability close to one or zero. We may summarize the above observations therefore as the following:

Corollary 5.1 *There exists $\varepsilon^* > 0$ such that all sufficiently small α , (i.e. $\alpha < \alpha_{\varepsilon^*}$), for any two committees (M, N) and (M', N) , there are at least two equilibria which are not comparable in terms of the expected search duration or in terms of which committee is more picky.*

Corollary 5.1 makes it clear that, unlike in AAV, it is impossible to draw any comparative statics either with respect to the size of the majority. It is also impossible to conduct a comparative statics exercise with respect to the magnitude of the need to belong.

5.3.2 Comparative Statics under the Pareto Criterion

Given the multiplicity of equilibria and the opposing comparative statics between the left extreme or the right extreme equilibrium with respect to α , we now investigate the expected search duration in the Pareto superior equilibria. The ex-ante payoff in an equilibrium with an acceptance threshold z is $V(z, \alpha)$. Let us first consider a conformal equilibrium with a high acceptance threshold, say some $z \in (1 - \varepsilon, 1)$, which exists for α small. Since the search continues with probability close to one in every period and each member deriving a flow utility of α , we have $V(y_r, \alpha) \approx \alpha/(1 - \delta)$ in any such equilibrium. On the other hand, in a conformal equilibrium where $z \in (0, \varepsilon)$, the search ends with probability close to one in the first period. Hence, $V(y_l, \alpha) \approx \mu + \alpha$ where $\mu = \int z dF(z)$ is the mean value of a candidate. Consequently, for small values of α , a Pareto superior equilibrium is *necessarily* a conformal equilibrium with a low acceptance threshold or a regular equilibrium, but a priori it is not possible to say which of these is in fact optimal. For small α , this depends on the relation between y^* , μ and the discount factor δ . In particular we have the following.

Proposition 5.4 *Suppose $M \neq N$. For all $\varepsilon > 0$ and sufficiently small,*

1. *If $y^* < \delta\mu$, the conformal equilibrium with the largest acceptance threshold in $(0, \varepsilon)$ is Pareto superior equilibrium. The presence of a need to belong therefore causes the committee to be less picky and decreases the expected search duration.*
2. *If $y^* > \delta\mu$, the Pareto superior equilibrium is a regular equilibrium. Moreover if*

$$M \geq (N + 1)/2 \text{ and } y^* > z_{med} \tag{5.9}$$

where z_{med} denotes the median of F , the presence of a need to belong causes the committee to be more picky and increases the expected search duration.

Recall that the expected search duration is $(1 - P(z, M, N))^{-1}$ when the acceptance threshold is z . It is increasing in z . Therefore, when inequality in Part 1

holds, in the Pareto optimal equilibrium, the presence of a need to belong causes the acceptance threshold to fall from y^* to a level that is no larger than ε . Expected search duration hence falls. In contrast, when it is regular equilibrium that is Pareto Optimal, we only know that it lies in the $(y^* - \varepsilon, y^* + \varepsilon)$ interval. Unless one imposes a further condition such as (5.9), it is in general not possible to say whether a regular equilibrium occurs to the right or to the left of y^* .

Since y^* is only implicitly determined in AAV as the fixed point of a certain function, it is admittedly hard to verify whether Part 1 or Part 2 of Proposition 5.4 actually applies in a given situation. However, a sense of when Part 2 applies may be gained by looking at the case where the value of the candidate follows a symmetric distribution. In this case, $\mu = z_{\text{med}}$. Consequently, should (5.9) hold then $y^* > \mu$ also holds and it is Part 2 that applies. It turns out (see AAV), higher values of δ are associated with a higher value for y^* . Thus, the inequality of (5.9) should be expected to hold for high values of δ . Now, a higher values of δ may be interpreted as more frequent arrival of options. Hence, one may conclude that when the arrival of options is frequent, under a simple or a super-majority rule, introduction of a need to belong makes the committee more picky and increases the expected search duration.

5.4 Discussion and Conclusion

The case of unanimity. When $M = N$, $\varphi(\cdot)$ has only one asymptote, at $z = 1$. It can be readily verified from following the proof of Proposition 5.2, that all the acceptance thresholds for conformal equilibria now appear in the $(1 - \varepsilon, 1)$ interval. The regular equilibria continue to exist as in the case where $M \neq N$. In this case, Part 1 of Proposition 5.4 is no longer applicable. Following the discussion at the beginning of Section 5.3.2, under unanimity then, the Pareto superior equilibrium is necessarily a regular equilibrium. Condition (5.9) is now sufficient to ensure that in the presence of a need to belong, under unanimity a committee necessarily becomes more picky.

Common-knowledge of α . One of the main difficulties with dropping the assumption that α is common-knowledge is that it causes a player's type to be multi-dimensional. As is well known, models of incomplete information with multi-dimensional types are far less tractable compared to the case where the type is a scalar. Moreover, if one were to assume that a player's need to belong is determined before the game begins, which seems the most reasonable assumption, one can no longer necessarily justify equilibria that do not condition on the past, since behavior in the previous periods could convey information about α . Consequently, the most optimistic scenario for achieving tractable solutions would be to assume that in each period a player's type - now a tuple (α_{it}, x_{it}) - is drawn with no correlation across time, across players or the two variables. Although an explicit analysis of this case too is beyond the scope of this paper, it is possible to offer a rough sketch of why the conformal equilibria may remain. Assume then that the need to belong is distributed on some interval $[0, \bar{\alpha}]$ independently of the value of the candidate. A player's type at any date is a tuple (α, x) and is drawn independently over time and across other players' types. A Markov strategy now consists of some acceptance *region* $Z \subset [0, \bar{\alpha}] \times [0, 1]$ such that at each date, a member votes for the search to continue if and only if it lies in Z . Z now plays the role of the acceptance threshold. For any given Z , we may calculate the various probabilities listed in Section 5.2. Proceeding similarly, we may obtain an analogue of (5.3) and (5.4) for the marginal type, which is now a pair (α, x) that satisfies the equation

$$x = \varphi(Z, M, N)\alpha + \delta V(Z, M, N)$$

In other words, given a region Z , will get a new region $Z' = \{(x', \alpha') | x' \leq \alpha\varphi(Z, M, N) + \delta V(Z, M, N)\}$ whereby a member votes for the search to continue only if her type lies in Z' . A Markov strategy profile identified by a region Z is an equilibrium if and only if $Z' = Z$. Questions of the existence of equilibria and their properties in this general setting take us beyond the scope of the current work. However, whenever the probability of Z is very high or a very low probability, the probability of being pivotal becomes close to zero. Then, the discussion at the top

of Section 5.3 would still apply, and one should similarly expect the existence of conformal equilibria under appropriate technical conditions.

Conclusion. In this brief note, we have studied the implications of perturbing the payoff structure in the canonical committee search problem explored in AAV. The perturbation is motivated by the “belongingness” theory of psychology. We have found that the introduction of an arbitrarily small perturbation of the original model along these lines creates multiple *interior* equilibria in a way that prevents any general comparative statics exercises across committee structures. Some headway can be made by selecting among the equilibria based on the Pareto principle. However, here too, whether the introduction of the need to belong makes the committee more or less conservative depends on the parameters of the model. The important extension of the model to incomplete information on the need to belong is an avenue for future research.

Chapter 6

**CARBON EMISSIONS AND INEQUALITY: AN
INTRATEMPORAL TRADEOFF WITH
INTERTEMPORAL CONSEQUENCES**

Over the last thirty years, income inequality and climate change have driven the political and economic debates all over the world. In the seminal contribution by [Kuznets \(1955\)](#), he argues an inverted U-shaped relationship between economic development and income inequality. The intuition is that as a poor country becomes richer, resources are allocated to the most productive agents in that economy and hence inequality increases. However, once the country has achieved some development threshold, then the political process takes over and there are redistributive policies that reduce inequality. Starting with the seminal work by [Grossman and Krueger \(1993\)](#), many have argued that there may be a similar Kuznets-type of relationship between pollution (emissions) and income (development). [Grossman and Krueger \(1993\)](#) find strong evidence of this type of U-shaped relationship between income and sulfur dioxide (SO₂). The mechanisms at work are basically the same as those proposed by Kuznets, hence the name Environmental Kuznets Curve (EKC). The EKC relationship between income and various other pollutants has been highly investigated with inconclusive empirical findings. Determining whether the EKC holds for global pollutants such as CO₂ is important because the EKC provides a strong rationale for the “grow now, clean later” argument that has been adopted by many fast-growing emerging economies.

Recently, the literature on the EKC has largely focused on carbon dioxide (CO₂) since it is considered to be the main driver of climate change. A growing body of research indicates that climate change may have important economic consequences. [Tol \(2002\)](#) shows that if global averages are used to estimate the costs induced by climate change, an increase in one Celsius degree in the planetary

mean surface air temperature would have a negative impact on GDP corresponding to 3%. Considering the low levels of economic growth experience around the world in the last decade, this is a significant impact that could accelerate the stagnation recently observed.

[Narayan and Narayan \(2010\)](#) study this relationship between income and carbon emissions in the context of short- and long-run income elasticities of emissions and find compelling evidence to support the EKC hypothesis. On the other hand, [Aslanidis and Iranzo \(2009\)](#) explore the heterogeneous nature of this relationship and find no evidence of the existence of an EKC. See [Heerink et al. \(2001\)](#) and the references therein for a further discussion on the mechanisms at work behind the EKC.¹

In early work, the study of the EKC was conducted by simply considering pollution levels against income. Even though this methodology provides some theoretical and empirical insights about the process of environmental degradation and economic development, its results are inconclusive and need further research as discussed in [Max-Neef \(1995\)](#). In an attempt to improve the analysis, [Heerink et al. \(2001\)](#) and more recently [Baek and Gweisah \(2013\)](#) include the role of income inequality. Thus, the analysis considers the interaction between carbon emissions, income and inequality. They discuss two potential mechanisms relating inequality and emissions.

First, a political economy hypothesis suggesting a positive relationship between these variables. This argument relies on the assumption that high levels of inequality lead to pro-growth reforms that do not take into account environmental degradation - or conversely, that lower levels of inequality lead to higher expenditure on pro-environmental policies. This is usually model using the median voter framework as described in [Kempf and Rossignol \(2007\)](#). The second mechanism is related to aggregate consumption and states that if people experience decreasing returns to consumption, and emissions are proportional to consumption, then we

¹The main articles are [Boyce \(1994\)](#), [Torras and Boyce \(1998\)](#), [Grossman and Krueger \(1995\)](#), and [Magnani \(2000\)](#).

expect a negative relationship between emissions and inequality, *ceteris paribus*. Therefore, if the aggregate consumption transmission channel dominates the political economy one, then we have a trade-off between carbon emissions and inequality. This is a non-trivial statement given the economic and political importance of both issues.

In this paper, we estimate the causal impact of income inequality on carbon emissions per-capita using a sample of 68 countries over a 50-year period from 1961 to 2010. We estimate different regressions and use two different datasets as a way to show the robustness of our results. Namely, the *All The Ginis* (ATG) dataset compiled by [Milanovic \(2014\)](#) and the Standardized World Income Inequality Database (SWIID) developed by [Solt \(2009\)](#). Our most reliable dataset is ATG since it uses data coming from actual surveys rather the imputed data as is the case of SWIID.

In our benchmark model, we find that the average treatment effect (ATE) of inequality on carbon emissions is such that a 1% decrease in inequality leads to approximately a 0.3% increase in carbon emissions. Our results agree with previous findings, including [Ravallion et al. \(2000\)](#), [Heerink et al. \(2001\)](#) and [Aslanidis and Iranzo \(2009\)](#) who find the existence of a trade-off between intra-country income inequality and carbon emissions.

Our work contributes to the literature in three key areas. First, we use a measure of inequality that is directly comparable across countries. The aforementioned studies used the [Deininger and Squire \(1997\)](#) dataset that provided the most extensive inequality information at that time. However, that dataset has some known problems related to coverage, quality and comparability between and within countries. We have upgraded the inequality data by using the most recent available datasets developed by [Milanovic \(2014\)](#) and [Solt \(2009\)](#). As a robustness check for the effect of consumption on carbon emissions, we look into the impact of different groups on emissions depending upon their relative shares of income. We use data on income shares by quintiles, and we find compelling evidence supporting the consumption hypothesis.

Second, we apply three methods to address the question of endogeneity between inequality and carbon emissions. We control for several observable channels that could plausibly affect both inequality and carbon emissions including political rights and years of schooling. We use instrumental variable estimation in a static panel context. We also use the generalized-method-of-moments (GMM) in a dynamic panel framework.

Third, we allow the effect of inequality on carbon emissions to be heterogeneous across income levels by using a panel smooth transition regression (PSTR) technique developed by [González et al. \(2005\)](#). We find that as income per-capita increases, the effect of inequality on emissions is less negative in a monotonic way. That is, changes on inequality have smaller effect on emissions for richer countries. This implies that the consumption effect becomes less and less important as income levels rise.

Last, as discussed in [Dasgupta et al. \(2002\)](#) and [Huang et al. \(2008\)](#), the international community needs a new and better regulatory framework to tackle the climate change phenomenon and its costs. This study shows that policies aiming at reducing inequality must take into account their potential spillovers on carbon emissions, the main source of climate change.

The rest of the paper is structured as follows. Section [6.1](#) describes the data and summarizes worldwide patterns of carbon emissions and inequality as well as trends by income groups and some representative countries. Section [6.2](#) describes the empirical methodology adopted, while Section [6.3](#) presents the results and discussion. Section [6.4](#) concludes. Details of the data and other robustness checks are given in Appendix E.

6.1 Stylized Facts

This section provides some descriptive statistics of the data on carbon emissions and inequality over the past few decades.² Two interesting facts emerge from our dataset. First, even though carbon emissions per-capita in the 2000s have de-

²The data set is available at <http://www.jorgerojas.cl/p/data.html>

cline compared to the levels of the 1980s, total carbon emissions have significantly increased at the worldwide level due to population growth. A second empirical observation is that income inequality has worsened in most countries around the world, with the largest increases occurring in low-middle- and low-income countries.

Fig. (6.1.a) shows these trends of increasing inequality and decreasing per-capita carbon emissions between 1980 and 2010. Fig. (6.1.b) shows that over time, lower income countries have converged to the levels of emissions per-capita of the high-income nations. Note that in 1977, the amount of emissions from lower income countries is so low that it is not visible in the chart. Fig. (6.1.c) shows that many countries have experienced an almost monotonic increase in income inequality, especially low-middle- and low income countries. See [Jaumotte et al. \(2013\)](#) for a detailed discussion on inequality trends.

This upwards trend on inequality coupled with the reduction on carbon emissions per-capita at the worldwide level (in our sample) suggests the dominance of the consumption effect of inequality over the political effect. However, technological progress and human capital may be confounding factors in this relationship. Thus, the observed trend needs to be further scrutinized as we do in Section 6.2.

To summarize this discussion, we see in Fig. (6.1.d) that the relationship between inequality and carbon emissions per-capita is not obvious due to large dispersion of the data and the multiple confounding factors. This simultaneous trends of worsening inequality and decreasing emissions raise the question of whether omitted or unobserved variables are driving a spurious relationship between these two variables, and underscore the importance of more rigorous efforts to determine whether this relationship is causal.

In the next subsection, we describe the data used and present some descriptive statistics to have a sense of the order of magnitude of important variables in our sample.

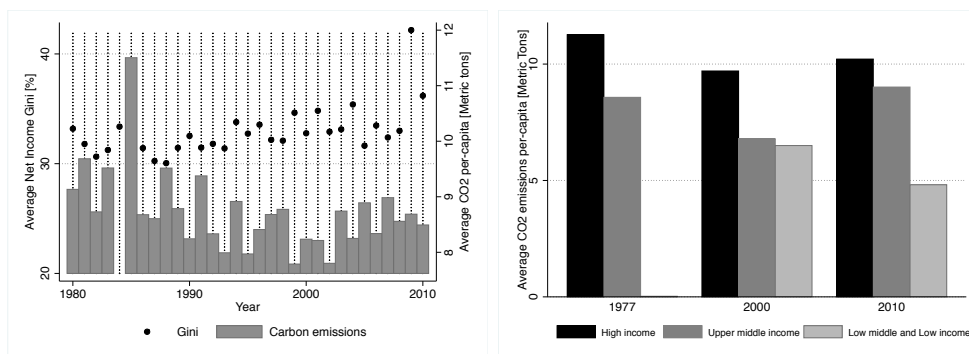

(a) CO₂ and Inequality in the World (b) CO₂ Contribution by Stage of Development

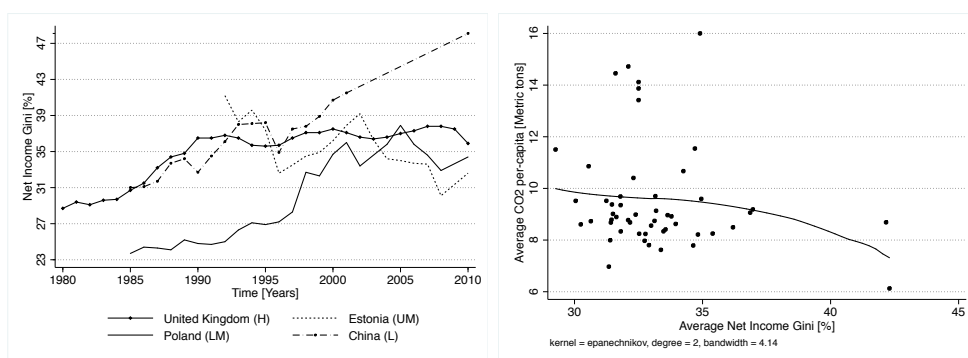

(c) Net Income Inequality in Selected Economies (d) Inequality vs CO₂ in the World

Figure 6.1: Stylized Facts

6.1.1 Data Description

Income inequality can be measured in net or gross terms. Net income refers to income after any transfers from or to the government, while gross income corresponds to income before any transfers. The most widely used measure of inequality is the Gini coefficient. Although it is a helpful measure, this index has some important limitations. First, the Gini coefficient mainly captures the degree of inequality in the middle of the distribution, ignoring to some extent the changes at the top and the bottom.

Second, the Gini measures relative inequality. Consider an economy populated

by only two individuals. One has income 10, while the other has income 100. The poor agent has 10% relative to the rich agent. If both double their incomes. Relative inequality will remain unchanged, but absolute inequality will increase from a gap of 90 to 180. Hence, the Gini does not inform about absolute changes. Thus, we may have a situation such that the Gini coefficient is increasing and at the same time, poverty levels may be decreasing. This implies the need for using income per-capita in all model specifications presented below. As a robustness check, we use net income shares by quintiles instead of the Gini coefficient. Using these two different measures of inequality provides valuable information about whether the relationship between inequality and carbon emissions is sensitive to the shape of the income distribution.

We use net income Gini coefficient data from two different sources: *All The Ginis* (ATG) by Milanovic (2014) and *Standardized World Income Inequality Database* (SWIID) by Solt (2009). The former provides only Gini coefficients estimated from actual households surveys providing a sample size for our analysis of 665 observations for a total of 68 countries covering the period 1961 to 2010.³ The latter provides standardized observations by employing a custom missing-data multiple-imputation algorithm that uses the Luxembourg Income Study (LIS) methodology as the standard.⁴ The disadvantage of this dataset is its imputed nature, but the great advantage is that we are able to increase our sample size to 4065 observations for a total of 165 countries covering the same period of time as before. Our main data for analysis are based on the ATG database. Namely, we prefer to rely on estimates of inequality from actual surveys rather than imputed data.

The quintile information is obtained from the *World Income Inequality Database*

³Income or expenditure surveys that provide information in net or gross terms.

⁴Hundreds of cross-country studies use the Deininger and Squire (1997) dataset. However, it is often hard to tell how or even whether authors have dealt with the problem of non-comparable Gini coefficients. Solt (2009) shows that Deininger and Squire's recommendations on how to use their data are often ignored or skipped by researchers. The same can be argued about discussing the use of imputed data. Thus, we emphasize the use of actual data that are comparable, while using imputed data only as a robustness check.

(WIID) available at the United Nations. Data on carbon emissions, income per-capita, economic growth and other macroeconomic variables are obtained from the World Development Indicators (WDI) database. Data on financial variables are obtained from Lane and Milesi-Ferretti (2007) updated to 2013. Data on domestic financial development are retrieved from the Global Financial Development Database (GFDD) at the World Bank. Data on educational attainment that serve as a proxy for human capital are obtained from Barro and Lee (2001) and Barro and Lee (2013). The political system is summarized by the political rights index provided by Freedom House (2015). More details about the data and the countries in the sample can be found in Appendix E.1.

Table 6.1 shows the descriptive statistics for our panel. The main information to consider from this table is related to the within and between variation of the data. We observe that most of the variation of the variables of interest corresponds to between variation. For instance, by looking at the Gini coefficient we observe that the overall standard deviation is 7.34, however, the proportion of that variation lies more heavily on the between dimension of the panel. This may represent a problem in our econometric methodology given that we use the within estimator also known as least square dummy variables (LSDV) estimator that uses the within information of the panel.⁵ Thus, by using country-specific effects we might remove most of the variation in our main explanatory variable. The same applies for carbon emissions per-capita. A secondary point is the overall variation in the sample and the extreme values on it. This addressed the concern of representativity. We observe that all variables cover most values existing around the world.

6.2 Empirical Analysis

In this section, we present the quantitative methodology to estimate the causal effect of income inequality on carbon emissions. Our main measure of inequality is

⁵For a detailed discussion of the problems of using panel techniques in a macroeconomic context; see Easterly et al. (1993) and Quah (2003).

Table 6.1: Descriptive Statistics for Full Sample with ATG data (1961-2010)

		Mean	Std. Dev.	Min	Max	Observations
CO ₂ per-capita	overall	8.79	4.09	0.03	27.42	N = 665
	between		4.33	0.03	22.70	n = 68
	within		1.06	3.40	13.50	T = 9.78
GDP per-capita	overall	20,797	15,610	189	87,716	N = 657
	between		15,368	196	70,023	n = 68
	within		5,622	-12,476	42,316	T = 9.66
Gini	overall	32.88	7.34	17.5	69.8	N = 665
	between		10.40	19.05	68.15	n = 68
	within		3.33	20.71	49.48	T = 9.78
Pol. Rights	overall	2.04	1.50	1	7	N = 631
	between		1.60	1	6.5	n = 67
	within		0.68	0.54	6.31	T = 9.41
Years of Schooling	overall	9.67	1.79	2.60	12.82	N = 155
	between		1.78	2.60	12.47	n = 45
	within		0.91	7.01	12.66	T = 3.44

Notes: Sources for all variables are in Appendix C.1. CO₂ is in units of metric tons per-capita, GDP per-capita is 2005 US\$, Gini is in net income from 0 (perfect equality) to 100 (one individual owns everything), Growth is in %, Political Rights is an index between 1.0 (free) and 7.0 (not free), Years of Schooling is in years.

the net income Gini coefficient, but we also apply the ratio of the richest quintile to the poorest quintile and the richest decile to the poorest decile. Furthermore, we check the robustness of this relationship by using Gini data based on the ATG and the SWIID databases as well as income shares by quintiles. To address endogeneity concerns that have been partially ignored in the existing literature we make use of country-specific effects coupled with instrumental variable estimation and

dynamic panel techniques. Last, we present our strategy to investigate possible heterogeneity of this relationship.

6.2.1 Methodology

Our focus is causal inference and heterogeneity analysis for the relationship between carbon emissions and income inequality. The former cannot be done by means of simple cross-sectional techniques because our data are observational rather than experimental. Hence, any relationship obtained by those means has the potential problem of representing spurious correlation. While correlation may offer valuable insight regarding causal relations, it is clearly not sufficient to define policy. Instead, we make use of panel-data estimation techniques to address causality.

As a baseline we start with a static panel with country and year fixed effects. This has the advantage that it allows us to remove any omitted variable bias (OVB) resulting from unobserved time-invariant characteristics such as culture and institutions. Notice that this technique does not correct for OVB due to unobserved characteristics that change over time. To deal with this we include multiple control variables that are known to be relevant for inequality and may have some explanatory power with respect to carbon emissions.

Regarding fixed effects, this technique presents some shortcomings in this particular case since income inequality is a rather stable variable over time. This problem is important since almost 78% of the variation in the income inequality in our data is due to variations between countries rather than within countries. Adding to this problem, we have the issues of attenuation bias and magnification error that are typical of panel data. For a longer discussion on this see [Griliches and Hausman \(1986\)](#) and [Bound and Krueger \(1991\)](#). All this reduces the precision of the estimates and makes harder to find statically significant results. Thus, results have to be interpreted with caution.

To address the endogeneity issue, we use three identification strategies and a few robustness checks. The first strategy is to use the within dimension of

the panel coupled with country and year fixed effects. Thus, we follow countries over time while controlling for unobservable country and year factors, as well as other observable characteristics. Year fixed effects are used to control for common global shocks that impact most if not all the countries in our sample. The period of analysis is from 1961 to 2010 with yearly frequency. In this period there were multiple events that affected many countries around the world. Some of the most significant ones are: the 1970s energy crisis associated mostly with the shortage of oil, the early 1980s recession related to the contractionary policies adopted to reduce inflation, the collapse of the Soviet Union in the early 1990s, the Asian Crisis in 1997 and the Great Recession starting in 2008. For all this, we must use year fixed effects. All these shocks may have distributional consequences as well as impacts on carbon emissions.

In our second strategy we extend the previous framework to allow for endogeneity of inequality. This obeys to our concern of reverse causality between emissions and inequality. [Lavy et al. \(2014\)](#) provide some evidence that pollution may have adverse effects on educational attainment and in turn this has an effect on inequality.⁶ Further consider the theoretical discussion in recent paper by [Taylor et al. \(2015\)](#) where they show the complexity of this relationship and the highly probable presence of confounding factors. Hence, we use instrumental variable (IV) estimation to treat for it. We instrument for inequality with a choice of lags of itself as described below and the tariff rate. [Rojas-Vallejos and Turnovsky \(2015\)](#) show theoretically that import tariff rates have distributional consequences, but there is no compelling reason to argue that tariffs have an impact on carbon emissions. This set of instruments passes the hypothesis tests without problems as shown below.

The third strategy consists in the use of the (GMM) estimator developed by [Arellano and Bond \(1991\)](#), [Arellano and Bover \(1995\)](#) and [Blundell and Bond \(1998\)](#). We apply the GMM estimator to our baseline regression and the dynamic

⁶Students from low-income families tend to endure more pollution than richer students. Hence, emissions may have a distributional effect.

panel that uses one lag of the dependent variable as a proxy for some of the sluggish omitted variables as discussed in [Breen and García-Peñalosa \(2005\)](#) and [Voitchovsky \(2005\)](#).

We perform four robustness checks. First, we use two alternative ways to measure inequality, namely, the ratio of the top 20% to the bottom 20% and the ratio of the top 10% to the bottom 10%. As an alternative to the panel specification we use a long-difference regression to quantify the relationship between inequality and emissions.⁷ The last robustness check is to estimate the effect of income shares on emissions over the income distribution profile.

Last, to investigate heterogeneity of the relationship we use a panel smooth transition regression (PSTR) model. This technique is flexible and is becoming popular to look into the nonlinear or heterogeneous effects on relationships that used to assume homogeneity and constancy over time.

6.2.2 Static Panel Analysis

The net income Gini coefficient is our choice to map inequality into the data. We consider the main determinants of carbon emissions as discussed in [Sharma \(2011\)](#). The set of control variables most directly relevant to emissions and inequality include the following: (i) Exports and imports, as possible sources of pollution due to economic activity; (ii) Foreign direct investment, portfolio equity, debt and financial derivatives. All of them summarized in financial liabilities and financial assets ([Lane and Milesi-Ferretti \(2007\)](#)); (iii) Domestic credit as a measure of financial deepening obtained from the World Bank.

Other regressors less directly relevant for emissions but nevertheless related to inequality include: (iv) Years of schooling and the fraction of the population with secondary schooling ([Li and Zou \(1998\)](#)); (iv) The role of human capital ([Barro and Lee \(2013\)](#)); (v) Lastly, political rights are a measure for the relative bargaining power of different groups. More details with respect to variables are provided in Appendix [E.1](#).

⁷For further details; see [Bergh and Nilsson \(2010\)](#) and [Sylwester \(2002\)](#).

Next, following the discussions [Box and Cox \(1964b\)](#) and [Aneuryn-Evans and Deaton \(1980\)](#), we determine that the most reliable functional specification for the regressions is in their logarithmic form rather than its level. Thus, the basic panel data model is given by,

$$c_{it} = \beta_0 + \beta_1\sigma_{it} + \beta_2y_{it} + \mathbf{X}\boldsymbol{\beta} + \delta_i + \delta_t + \varepsilon_{it} \quad (6.1)$$

where c_{it} denotes the logarithm of carbon emissions per-capita for country i at time t , σ_{it} is our measure of inequality - the logarithm of net income Gini - y_{it} is the logarithm of GDP per-capita, and \mathbf{X} is a matrix of control variables that does not include inequality and income. δ_i is the country time-invariant unobservable heterogeneity (country fixed effects), δ_t is the time fixed effects that capture common temporal shocks and ε_{it} captures all the omitted factors. All this within the framework of the conditional independence assumption (CIA).⁸ We apply IV estimation to this model as described above.

6.2.3 Dynamic Panel Analysis

As an alternative to deal with unobserved heterogeneity, we propose the use of lagged carbon emissions as an explanatory variable. The logic behind is that using a lag of carbon emissions as an explanatory variable may help to deal with some of the unobserved time-variant heterogeneity. If omitted variables evolve sluggishly over time, then they will also determine carbon emissions in previous periods and therefore using a lag of carbon emissions may account for some of these sluggish omitted variable.⁹ Notice, however, that including a lag of the dependent variable, as control, will make estimates biased and inconsistent even if the residuals are

⁸This assures that given the CIA, conditional on observable characteristics, comparisons of average carbon emissions across inequality levels have a causal interpretation. See section 3.2 in [Angrist and Pischke \(2009\)](#) for a detailed discussion.

⁹The dynamic model (6.2) provides three reasons for correlation in c_{it} over time. First, directly through c in preceding periods, called true state dependence; second, directly through observables \mathbf{X} , called observed heterogeneity; and third, indirectly through the time-invariant country-specific effect δ_i , called unobserved heterogeneity.

not serially correlated.¹⁰ See [Nickell \(1981\)](#), [Bond et al. \(2001\)](#) and [Voitchovsky \(2005\)](#) for further discussion on this point.

The dynamic panel model is given by,

$$c_{it} = \beta_0 + \alpha c_{it-1} + \tilde{\mathbf{X}}\boldsymbol{\beta} + \delta_i + \delta_t + \varepsilon_{it} \quad (6.2)$$

where $\tilde{\mathbf{X}}$ represents the control variables in \mathbf{X} including inequality and income.

To tackle the problem of endogeneity, we first-order difference the previous model obtaining,

$$(c_{it} - c_{i,t-1}) = \alpha(c_{i,t-1} - c_{i,t-2}) + \beta(\tilde{X}_{it} - \tilde{X}_{i,t-1}) + (\delta_t - \delta_{t-1}) + (\varepsilon_{it} - \varepsilon_{i,t-1}) \quad (6.3)$$

by doing this, we can remove the unobserved time-invariant heterogeneity, δ_i , and appropriate instruments can control for endogeneity and measurement error. This methodology has been widely applied in the growth-inequality literature. See [Forbes \(2000\)](#) and [Voitchovsky \(2005\)](#). Then we use sufficiently lagged values of c_{it} and \tilde{X}_{it} as instruments for the first-differences, $(c_{i,t-1} - c_{i,t-2})$ and $(\tilde{X}_{it} - \tilde{X}_{i,t-1})$ in (6.3) such that we avoid serial correlation.¹¹ However, the differencing procedure may discard much of the information in the data since the largest share of variation in income inequality and income, the main explanatory variables, is between countries rather than within countries.¹² As a result, it is not clear that relying solely on the limited within country information is the best option. [Dollar and Kraay \(2002\)](#) argue that the restricted time-series variation in the inequality data might make it difficult to estimate coefficients with any precision. See the discussion in Section 6.2.1 for more details.

Therefore, we also apply the system GMM estimator developed by [Arellano and Bover \(1995\)](#) and [Blundell and Bond \(1998\)](#). The system GMM allows us

¹⁰This is so because the within model will have the first regressor $c_{i,t-1} - \bar{c}_i$ that is correlated with the error $\varepsilon_{it} - \bar{\varepsilon}_i$, because $c_{i,t-1}$ is correlated with $\varepsilon_{i,t-1}$ and hence with $\bar{\varepsilon}_i$.

¹¹In order to get a consistent estimator for α and β , instruments should be correlated with the first differences $(c_{i,t-1} - c_{i,t-2})$ and $(\tilde{X}_{it} - \tilde{X}_{i,t-1})$ respectively, but not with the differenced error term $(\varepsilon_{it} - \varepsilon_{i,t-1})$. Different lagged values of the variables should be used as instruments depending on the degree of endogeneity in the variables.

¹²Most of the variation in the data is between-country variation. 93% for carbon emissions, 78% for income inequality, and 86% for GDP per-capita.

to retain some of the information present in the level equations. Provided the additional instruments are valid, then the system GMM estimator tends to have better sample properties compared to the first-differenced GMM estimator, since it exploits the time-series information available more efficiently. Specifically, the system is jointly estimated using first-difference equations instrumented by lagged levels and using level equations instrumented by the first differences of the regressors. If these variables are appropriate instruments, the estimator should be consistent in the presence of endogenous variables. The system GMM estimator is also consistent in the presence of country fixed effects and the estimation method works for unbalanced panels and situations with few periods and many countries.¹³

To get a better understanding of the behavior of the parameters, we apply both the first-difference GMM estimator and the system GMM estimator.¹⁴

6.2.4 Heterogeneity Analysis (PSTR)

We use a PSTR model following the procedure described by [González et al. \(2005\)](#). The objective is to determine whether the relationship between emissions and inequality is nonlinear or said in a different way, whether there is heterogeneity.¹⁵ [Ravallion et al. \(2000\)](#) present compelling evidence on how income level and inequality may interact. Therefore, we specified our source of heterogeneity by the income level. This also makes intuitive sense because inequality at high levels of income not necessarily imply the same effects in terms of magnitude, even if the sign of the effect is the same. [Aslanidis and Iranzo \(2009\)](#) perform this type of analysis but ignoring the effect of income inequality. In this sense, we contribute

¹³There are one-step and two-step GMM estimators. As explained in [Bond et al. \(2001\)](#), if the sample is finite, then the asymptotic standard errors associated with the two-step GMM estimators can be seriously biased downwards, and thus form an unreliable guide for inference. Hence, we apply the [Windmeijer \(2005\)](#) correction.

¹⁴We use the Stata command `xtabond2` developed by [Roodman \(2009\)](#). See his paper for a details on the syntax and use of this command.

¹⁵See [Duarte et al. \(2013\)](#), [Thanh \(2015\)](#), and [López-Villavicencio and Mignon \(2011\)](#) for papers that apply this technique in detail.

to expand their insight on this relation. The PSTR model is specified as follows,

$$c_{it} = \delta_i + \beta_0 \sigma_{it} + \beta_{20} y_{it} + \beta_1 \sigma_{it} g(q_{it}; \gamma, \lambda_j) + \varepsilon_{it} \quad (6.4)$$

where the variables are defined as before and q_{it} is the transition variable/s that in our case corresponds to GDP per-capita. The transition function $g(q_{it}; \gamma, \lambda_j)$ is defined as,

$$g(q_{it}; \gamma, \lambda) = \left[1 + \exp \left(-\gamma \prod_{j=1}^m (q_{it} - \lambda_j) \right) \right]^{-1} \quad (6.5)$$

where γ denotes the speed of transition and λ_j the threshold parameters for the different regimes. Next, we briefly outline the procedure.

First, we test for homogeneity against nonlinearity assuming a logistic transition and an exponential transition. As described in [González et al. \(2005\)](#), testing $H_0 : \gamma = 0$ is non-standard since under H_0 the model contains unidentified nuisance parameters. Therefore, we use a first-order Taylor expansion of $g(q_{it}; \gamma, \lambda_j)$ around $\gamma = 0$ which after reparameterization leads to the following regression,

$$c_{it} = \delta_i + \beta_0^* \sigma_{it} + \beta_1^* \sigma_{it} q_{it} + \dots + \beta_m^* \sigma_{it} q_{it}^m + \varepsilon_{it}^* \quad (6.6)$$

with this we carry on a series of hypothesis testing to check for: homogeneity of the relationship, validity of a linear model against the PSTR model, check for any remaining heterogeneity and test for parameter constancy. Details are described in [González et al. \(2005\)](#).

Thus, we estimate parameters for the PSTR model. This is a two-step iterative process that consists of first subtracting the country-regime-level means from the data and then estimating the parameters via non-linear least squares using the BFGS algorithm.¹⁶ In a PSTR model, the transition function is assigning each observation to a regime or combination of regimes, and therefore the country-regime-level mean is dependent on the parameters γ and λ_j .

Given our chosen functional form, we can write the inequality elasticity of

¹⁶The Broyden-Fletcher-Goldfarb-Shanno (BFGS) algorithm is of the Newton-Raphson type, and is implemented in a package in the Regression Analysis Time Series (RATS) software.

emissions, ξ_{it} , by the following equation,

$$\xi_{it} = \beta_0 + \beta_1 g(q_{it}; \gamma, \lambda_j) \quad (6.7)$$

6.2.5 Robustness Checks

We re-estimate our static panel model using the alternative measures of inequality described before. In addition, we use data on income shares by quintiles on the benchmark model, and a long-difference regression. The long-difference regression is specified as follows,

$$(\Delta c)_i = \alpha + \beta (\Delta \sigma)_i + \mathbf{X}_{i,1990} \boldsymbol{\gamma} + \varepsilon_i \quad (6.8)$$

6.3 Results

The static analysis is performed using the ATG dataset that covers 68 countries between 1961 and 2010, while the dynamic and PSTR analyses use the SWIID dataset that covers 118 countries between 1980 and 2010. Details are described in Appendix [E.1](#).

6.3.1 Static Panel

Before estimating our model, we study the pairwise correlations among independent variables. As Tables [E.3a-E.3b](#) show, some of the variables are highly correlated. Examining the variance inflation factor (VIF), we observe that there may be some multicollinearity issues if all relevant variables are included.¹⁷ Hence, we look for a benchmark model containing the most relevant and significant variables related to our question.

The results for the panel estimation with country-specific and period-specific effects are summarized in Table [6.2](#). We have estimated different model specifications. The simplest model, the regression of the logarithm of carbon emissions

¹⁷The VIF test can only be computed for pooled regressions. A usual critical value considered in the literature is 10. If the VIF of a given variable is greater than 10, then this variable may present some important collinearity with the other variables in the model. Thus, increasing the size of standard errors. See Table [E.4](#) for our full model and benchmark model, respectively.

per-capita on the logarithm of the income Gini coefficient, is reported in column (1). We see that estimate is negative and significant at the 1% significance level. Omitted variable bias problems may be present, so we perform the analysis using a model with many of the variables discussed in the literature that may have an impact on both inequality and emissions. This is the full model reported in column (2). The controls include: measures of income per-capita, international trade, financial integration, domestic financial development, human capital and political system. Most of the variables in this specification are insignificant.

Due to the strong presence of collinearity between the explanatory variables we reduce the model to the one shown in column (3). We observe that inequality and income per-capita are the variables with the higher explanatory power. A further reduction shows that the variables that better explain carbon emissions correspond to inequality, income per-capita and years of schooling. This result is strikingly aligned with the theoretical literature, but is purely obtained from the data. This is reported in column (4). The estimated income elasticity is 0.48, a result well within the range of previous panel studies. [Aslanidis and Iranzo \(2009\)](#) find an income elasticity that varies between 0.46 and 0.65, however, they do not report any values for inequality since it was not a variable in their analysis. [Heerink et al. \(2001\)](#) in a cross-sectional study find much larger values for both income and inequality elasticities. These values are of approximately 5.57 and -1.12, respectively. However, this is subject to all the criticisms of cross-sectional studies. In addition, their sample is rather small with only 64 data points.

We observe that the estimate on inequality is larger in the cases with less controls. This suggests the possibility that the omitted variable bias could increase the size of the average effect of income inequality on carbon emissions. However, determining the bias depends upon the way the variables are correlated with each other and the endogeneity of other variables. Hence, affirming the sign of the bias with certainty is not possible. Nevertheless and given our multiple robustness checks, we are confident on the sign of the income inequality effect on carbon emissions. Furthermore, we want to understand how inequality interacts with the

Table 6.2: Carbon Emissions and Income Inequality Regressions: Log(CO₂ per-capita)

	Naive Model	Full Model	Long Model	Benchmark Model	IV-Model
	(1)	(2)	(3)	(4)	(5)
Gini	-0.308*** (-2.44)	-0.139 (-1.26)	-0.186* (-1.63)	-0.318*** (-3.12)	-0.462*** (-2.90)
GDP per-capita		0.459*** (4.33)	0.443*** (4.24)	0.483*** (6.22)	0.413*** (7.46)
Trade Variables					
Exports		0.090 (0.89)			
Imports		-0.210 (-1.57)	-0.128 (-1.23)		
Financial Variables					
Financial Assets		0.066 (1.23)			
Financial Liabilities		-0.088 (-1.44)	-0.058 (-1.11)		
Domestic Credit		-0.002 (-0.05)			
Institutional Variables					
Years of Schooling		0.478 (1.43)	0.537 (1.56)	0.524* (1.76)	0.427 (1.44)
Political Rights		-0.024 (-0.87)			
Observations	665	568	582	615	264
# Countries	68	60	60	61	27
Adjusted R^2	0.102	0.248	0.242	0.308	
Kleibergen-Paap test (p -value)					0.00
Hansen J statistic (p -value)					0.94

Notes: The models are estimated using panel regressions with with country fixed effects and time dummies. Standard errors are clustered at the country level. t statistics in parentheses. * $p < 0.10$, ** $p < 0.05$, *** $p < 0.01$. All explanatory variables are expressed in terms of percentage of GDP, except the Gini coefficient and the political rights measure. All explanatory variables are in natural logarithm, except the political rights index. The Kleibergen-Paap test is an under-identification test with a null of no canonical correlation between the endogenous regressor and the instruments. The Hansen J statistic is an exclusion restriction test with null of no correlation between the instruments and the error term. Inequality is instrumented by tariff rates and the second lag of itself.

level of income. Thus, the best model to address this question is our benchmark model.

We perform the Hausman test to the benchmark specification and we find that fixed effects are more appropriate than random effects. This is sensible in our context.

Inequality may be endogenous because of confounding variables, hence we apply instrumental-variable estimation with a 2-step GMM estimator. This is reported in columns (5). We instrument inequality with tariffs as argued in the previous section. We also use the second lag of inequality as an instrument. This specification satisfies the relevance and validity of the instruments. The Kleibergen-Paap test rejects the null of no correlation between the instruments and the endogenous regressor, while the Hansen J test fails to reject the null of no correlation between the instruments and the error term. Thus, the IV estimate of the inequality elasticity is -0.46.

6.3.2 Dynamic Panel

Our panel based on the ATG data is very unbalanced. To reduce this problem we use the SWIID that have a larger number of observations, but with the disadvantage of these data being imputed. Although we alleviate the problem of missing observations, the problem still persists. This is important because if we use a dynamic model with one lag of the dependent variable if there are too many missing observations in consecutive years, then that will drop some other observations when applying the first-difference model. This decreases the sample size significantly.

Thus, to apply the dynamic model, we balance the panel obtained with the SWIID data by taking averages every 5 years of the different variables. By doing this, we obtain a sample of 118 countries with 4 periods, where each period corresponds to the average of 5 years. The period analyzed corresponds to 1991 to 2010. The results of the dynamic panel are reported in Table 6.3. Columns (1) and (3) report the first-difference GMM estimation, while columns (2) and (4) report the

Table 6.3: Dynamic Panel Regressions: Log(CO₂ per-capita)

	GMM-DIF	GMM-SYS	GMM-DIF	GMM-SYS
	(1)	(2)	(3)	(4)
CO ₂ ($t - 1$)	0.258*	0.368***	0.334**	0.473*
	(1.76)	(2.93)	(2.19)	(1.75)
Gini	-0.524	-1.038***	-1.077**	-0.876**
	(-1.22)	(-3.05)	(-2.04)	(-2.30)
GDP per-capita	0.761***	0.537***	0.830***	0.484**
	(4.76)	(3.08)	(4.82)	(1.93)
Years of Schooling			-0.154	-0.165
			(-0.39)	(-0.44)
Serial Correlation (p -value)	0.95	0.39	0.86	0.74
Hansen J -test (p -value)	0.16	0.07	0.31	0.35
Observations	236	354	210	315
# of instruments	8	14	11	17

Notes: 1. Year dummies are included in all specifications. Two-step estimation with Windmeijer (2005) finite sample correction. t statistics in parentheses. * $p < 0.10$, ** $p < 0.05$, *** $p < 0.01$. Units of variables defined as in Table 6.2.

2. Serial correlation test for first-order serial correlation in the first-differenced residuals, asymptotically distributed as $N(0, 1)$ under the null of no serial correlation.

3. Hansen J -test is a test of over-identifying restrictions, asymptotically distributed as χ^2 under the null of instrument validity, with degrees of freedom reported in parentheses.

system GMM output. We allow for endogeneity in all variables with the sole exception of the period-specific effects that are regarded as exogenous.

We observe that the level of carbon emissions in the previous year tend to increase the level of emissions in the current one. This behavior may be related to sluggish variables such as technology, human capital and institutional factors that make difficult to reduce emission levels. We can also see that the effect of inequality continues to be negative and significant in the case of our benchmark specification. Thus, we are confident on the negative sign of inequality. However, the magnitude

is larger than the one reported in Table 6.2. This could be interpreted as inequality having a larger impact on carbon emissions growth than in the level of carbon emissions. Our findings are in line with Baek and Gweisah (2013) who estimate the long-run and short-run effects of inequality on emissions but only for the case of the United States.

6.3.3 Heterogeneity

In this section, we address the issue of heterogeneity in the relationship between emissions and inequality. We argue that the same level of inequality may have a different effect on emissions depending upon the level of income. Consider two economies with the same income Gini coefficient. If country A has an income level that allows their citizens to enjoy a good standard of living, while country B's income level only allows barely subsistence. Then the effect of changes on inequality will be different. We expect that in the rich country the political effect dominates the consumption effect. People in a rich economy are most likely consuming what they want and perhaps investing in financial assets either domestically or abroad. Therefore, as inequality increases, even conjecturing that some groups consume less, this is not the effect that dominates. What dominates is the political pressure by the groups falling behind for pro-growth policies so they can catch up with richer groups. The reverse is expected to hold in a poor country.

Table 6.4 reports the estimation output of the PSTR model given by,

$$c_{it} = \delta_i + \beta_0 \sigma_{it} + \beta_{20} y_{it} + (\beta_1 \sigma_{it} + \beta_{21} y_{it}) g(y_{it}; \gamma, \lambda) + \varepsilon_{it} \quad (6.9)$$

We also estimated the model using inequality and income as transition variables, but we rejected an interaction of inequality with itself. However, the interaction of inequality with income was significant, and those are the results presented. Ravallion et al. (2000) also provide some support for this interaction, although they assume a linear interaction rather than the more flexible approach in this analysis. We performed the usual four hypothesis tests in this type of econometric modeling. First, we test for homogeneity. Following the discussion in González et al. (2005),

Table 6.4: Panel Smooth Transition Regression
 Log(CO₂ per-capita)

	PSTR	
	Coef.	t-Stat
Gini (β_0)	-0.617***	-3.37
Transition Variable (GDP per-capita)		
Gini (β_1)	0.744*	1.67
GDP per-capita	0.757***	6.54
GDP per-capita	-0.521***	-4.01
Transition Parameters		
$\hat{\lambda}$ (GDP per-capita threshold)	14,913	
$\hat{\gamma}$ (Speed of transition)	0.942	
Homogeneity Tests		
		<i>p</i> -value
$H_0^* : \beta_1^* = \beta_2^* = \beta_3^* = 0$		0.00
$H_0^* : \beta_3^* = 0$		0.00
$H_0^* : \beta_2^* = 0 \beta_3^* = 0$		0.16
$H_0^* : \beta_1^* = 0 \beta_2^* = \beta_3^* = 0$		0.00
Linearity Test against PSTR		
with $m = 1, r = 1$		0.00
No Remaining Heterogeneity Test		0.60
Parameter Constancy Test		0.56

Notes: * $p < 0.10$, ** $p < 0.05$, *** $p < 0.01$. The sample consists of 92 countries over 5 periods of time of 5 years each from 1985 to 2010. The income per-capita threshold is the antilogarithm of the estimated threshold in logs that corresponds to 9.61.

if the hypothesis that is strongly rejected corresponds to $H_0^* : \beta_2^* = 0 | \beta_3^* = 0$, then we should choose $m = 2$, if $H_0^* : \beta_3^* = 0$ or $H_0^* : \beta_1^* = 0 | \beta_2^* = \beta_3^* = 0$ are the ones strongly rejected then we should choose $m = 1$. Given the results shown in Table 6.4, we reject homogeneity and we choose a parameter $m = 1$.

Then we test linearity against the PSTR model. We reject the linear model confidently. Hence, we proceed to estimate the model. Having estimated the model, we test for no remaining heterogeneity, and we fail to reject this hypothesis. Last, we test the null of parameter constancy and we also fail to reject this. Therefore, we interpret the parameters shown in the first part of Table 6.4.

We observe that inequality has a negative elasticity on emissions for most values of income. The poorer the country, the larger the inequality elasticity on emissions. This is graphically shown in Figure 6.2. Thus, as the country gets richer the consumption effect dominates less and less until eventually be surpassed by the political effect. The switch in regimes happens around fifteen thousands dollars.

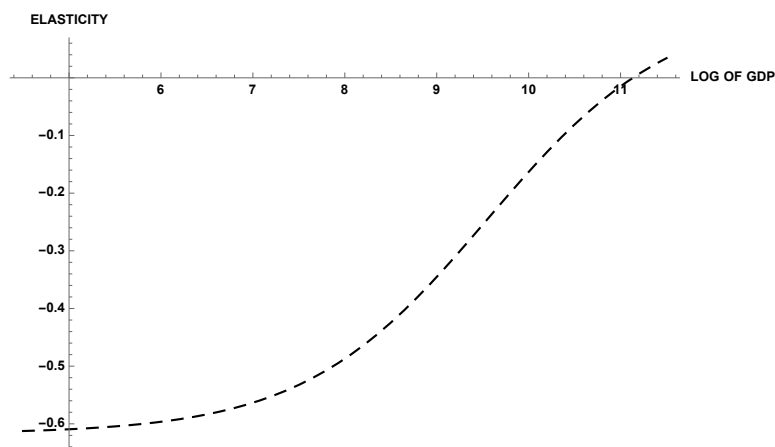

Figure 6.2: Heterogeneity Analysis for the Inequality Elasticity of Carbon Emissions

Baek and Gweisah (2013) find that for the US, the inequality elasticity is positive. So, our finding is confirmed by theirs in the sense that richer countries may experience a reduction of emissions given a reduction in inequality.

Another interesting result in Table 6.4 is that the data do not support the

presence of an EKC. We observe that as income increases, emissions increase at a diminishing rate but never start reducing. This result is similar to the one presented in [Aslanidis and Iranzo \(2009\)](#). Notice, however, that they do not control for inequality and use only nonOECD countries. We use a larger number of countries, 92, in contrast to their 77 developing economies. They focus on the period 1971 to 1997, while we analyze the period 1985 to 2010. The findings differ in magnitude, but not qualitatively which further suggests the stability of the relationship between income and emissions.

6.3.4 Robustness

Table 6.5 provides some robustness checks using our benchmark specification for the inequality-emissions relationship by using different measures of inequality. Column (1) uses the ratio of the top 20% to the bottom 20% of the income distribution.

Table 6.5: Robustness Checks Panel Regressions

Independent Variable	Log(CO ₂ per-capita)		
	Log(Q5/Q1) (1)	Log(D10/D1) (2)	Long Reg SWIID (3)
Inequality Measure	-0.151*** (-3.67)	-0.092*** (-2.90)	-0.590* ^d (-1.95)
GDP per-capita	0.322*** (3.36)	0.307*** (3.13)	1.019*** ^d (5.44)
Years of Schooling	0.266 (1.11)	0.268 (1.09)	0.112*** ^l (3.40)
Observations	693	689	79
# Countries	62	62	79
Adjusted R^2	0.162	0.154	-

Notes: As in Table 6.2. The SWIID dataset uses 100 imputations. *d* denotes the long difference of the variable, while *l* denotes the variable at 1992.

We see that the effect of inequality on emissions is negative and strongly statis-

tically significant. A similar result is obtained when using the top 10% to the bottom 10% as reported in column (2). Next, we use the SWIID and a reduce model. Using net income Gini data we fail to find significance, while with gross income Gini coefficients we find a significant negative effect. Last, we make use of a long-difference regression to see long-run effects of inequality and we find a negative significant effect that is larger than the one in the short run. [Aslanidis and Iranzo \(2009\)](#) find a similar qualitative behavior for the case of the United States.

Table 6.6: Net Income Shares by Quintiles Panel Regressions: Log(CO₂ per-capita)

	Q1 (Poorest)	Q2	Q3	Q4	Q5 (Richest)
First Quintile	0.195*** (3.54)				
Second Quintile		0.312*** (2.71)			
Third Quintile			0.255 (0.92)		
Fourth Quintile				-0.349 (-0.88)	
Fifth Quintile					-0.401** (-2.33)
GDP per-capita	0.320*** (3.32)	0.335*** (3.37)	0.312*** (3.05)	0.308*** (2.87)	0.333*** (3.33)
Years of Schooling	0.285 (1.19)	0.255 (1.06)	0.264 (1.13)	0.322 (1.37)	0.291 (1.24)
Observations	693	693	693	693	695
# Countries	62	62	62	62	63
Adjusted R^2	0.163	0.146	0.129	0.129	0.156

Notes: The models are estimated using panel regressions with with country fixed effects and time dummies. Standard errors are clustered at the country level. t statistics in parentheses. * $p < 0.10$, ** $p < 0.05$, *** $p < 0.01$. All explanatory variables are in natural logarithm.

Table 6.6 shows that poorest groups tend to contribute much more to carbon emissions than richer groups when their incomes increase. Furthermore, the richest 20% of the population decrease overall carbon emissions. This could be interpreted as an overall reduction in consumption given that we control for GDP per-capita. Thus, redistributing income from the rich to the poor increases consumption coupled with carbon emissions, and vice versa.

6.4 Conclusions

This paper has explored the inequality-emissions relationship using panel data for 68 countries over the period 1961 to 2010. Our results suggest that the inequality elasticity of carbon emissions lies in a range between -0.46 and -0.30. That is, on average, a 1% reduction in income inequality leads to an increase of approximately 0.30% in carbon emissions per-capita. This implies that there is an intratemporal tradeoff between inequality and carbon emissions.

This is an important result since many governments around the globe are trying to address climate change and inequality simultaneously. If reducing inequality, increases carbon emissions per-capita, then this represents a challenge for public policy. In the literature we may find effective policies targeting inequality or climate change, but this study shows that we should design a policy mix that can deal with both issues. The ideal is to find a market-based policy that can endogenously tackle inequality and emissions so that we may minimize command-and-control regulations.

Our analysis addresses endogeneity issues explicitly and the results are robust across all different specifications. In addition, we use different measures of inequality and the relationship continue to hold in terms of its statistical significance and sign. This is further confirmed by exploring the impact of redistribution of income on carbon emissions. As poorer people get a larger share of income or equivalently as inequality between rich and poor is reduced, the level of emissions increase.

Most of the literature in this topic discusses the presence of two opposite effects. The aggregate consumption effect that reduces carbon emissions per-capita as

inequality increases, and the political process effect that increases emissions as inequality rises. We perform a panel smooth transition regression analysis to explore what effect dominates depending upon the level of development using as a proxy income per-capita. We find that the consumption effect dominates most of the range of income. However, as income rises the consumption effect gets smaller and smaller, until eventually the political process effect dominates for high levels of income.

A few paths for further research are: exploring the relationship between human capital, technology and emissions, and the impact of the profile of the income distribution on emissions. In this study we find that the behavior of human capital is non-monotonic with respect to carbon emissions. This could be related to its productivity effects combined with the political ones. It seems that at low stages of development, productivity effects dominate over the political one. However, the reverse may hold at higher stages of development. Another likely explanation is associated with the technology frontier in the country. As countries get richer and access the technological frontier could also decrease their emissions level. Thus, disentangling these effects is an interesting path to pursue.

BIBLIOGRAPHY

Technical report.

Aguiar, M. and Gopinath, G. (2006). Defaultable debt, interest rates and the current account. *Journal of International Economics*, 69:64–83.

Aiyagari, S. (1994). Uninsured idiosyncratic risk and aggregate saving. *The Quarterly Journal of Economics*, 109(3):659–684.

Akerlof, G. and Kranton, R. (2000). Economics and identity. *The Quarterly Journal of Economics*, 115:715–753.

Akerlof, G. and Kranton, R. (2005). Identity and the economics of organizations. *The Journal of Economic Perspectives*, 19:9–32.

Albertus, M. and Menaldo, V. (2016). Capital in the twenty-first century - In the rest of the world. *Annual Review of Political Science*, 19.

Albrecht, J., Anderson, A., and Vroman, S. (2010). Search by committee. *Journal of Economic Theory*, 145:1386–1407.

Alesina, A. and Rodrik, D. (1994). Distributive politics and economic growth. *The Quarterly Journal of Economics*, 109(2):465–490.

Aneurn-Evans, G. and Deaton, A. (1980). Testing linear versus logarithmic regression models. *The Review of Economic Studies*, 47:275–291.

Angrist, J. and Pischke, J. (2009). *Mostly Harmless Econometrics: An Empiricists Guide*. Princeton: Princeton University Press.

Arellano, M. and Bond, S. (1991). Some tests of specification for panel data: Monte carlo evidence and an application to employment equations. *The Review of Economic Studies*, 58:277–297.

- Arellano, M. and Bover, O. (1995). Another look at the instrumental variable estimation of error-components models. *Journal of Econometrics*, 68:29–51.
- Aslanidis, N. and Iranzo, S. (2009). Environment and development: is there a kuznets curve for co2 emissions? *Applied Economics*, 41:803–810.
- Atkinson, A. (2003). Income inequality in OECD countries: Data and explanations. *CESifo Economic Studies*, 49:479–513.
- Atolia, M., Chatterjee, S., and Turnovsky, S. (2012). Growth and inequality: Dependence on the time path of productivity increases (and other structural changes). *Journal of Economic Dynamics and Control*, 36:331–348.
- Austen-Smith, D. and Banks, J. (1996). Information aggregation, rationality, and the Condorcet jury theorem. *American Political Science Review*, 90:34–45.
- Baek, J. and Gweisah, G. (2013). Does income inequality harm the environment?: Empirical evidence from the united states. *Energy Policy*, 62:1434–1437.
- Balassa, B. (1964). The purchasing-power parity doctrine: A reappraisal. *Journal of Political Economy*, 72:584–596.
- Barro, R. (2000). Inequality and growth in a panel of countries. *Journal of Economic Growth*, 5(1):5–32.
- Barro, R. and Lee, J. (2001). International data on educational attainment: Updates and implications. *Oxford Economic Papers*, 53(3):541–563.
- Barro, R. and Lee, J. (2013). A new data set of educational attainment in the world, 1950–2010. *Journal of Development Economics*, 104:184–198.
- Baumeister, R. and Leary, M. (1995). The need to belong: Desire for interpersonal attachments as a fundamental human motivation. *Psychological Bulletin*, 117:497–529.
- Bergh, A. and Nilsson, T. (2010). Do liberalization and globalization increase income inequality? *European Journal of Political Economy*, 26:488–505.

- Bernheim, B. (1994). A theory of conformity. *Journal of Political Economy*, 102:841–877.
- Beyer, H., Rojas, P., and Vergara, R. (1999). Trade liberalization and wage inequality. *Journal of Development Economics*, 59:103–123.
- Bikhchandani, S., Hirshleifer, D., and Welch, I. (1998). Learning from the behavior of others: Conformity, fads, and informational cascades. *The Journal of Economic Perspectives*, 12:151–170.
- Blundell, R. and Bond, S. (1998). Initial conditions and moment restrictions in dynamic panel data models. *Journal of Econometrics*, 87:115–143.
- Bohara, A., Gawande, K., and Sanguinetti, P. (2004). Trade diversion and declining tariffs: Evidence from Mercosur. *Journal of International Economics*, 64:65–88.
- Bond, S., Hoeffler, A., and Temple, J. (2001). Gmm estimation of empirical growth models. *CEPR Discussion Papers 3048*.
- Bound, J. and Krueger, A. (1991). The extent of measurement error in longitudinal earnings data: Do two wrongs make a right? *Journal of Labor Economics*, 9:1–24.
- Bourguignon, F. and Morrisson, C. (1990). Income distribution, development and foreign trade: A cross-sectional analysis. *European Economic Review*, 34:1113–1132.
- Bourguignon, F. and Morrisson, C. (1998). Inequality and development: The role of dualism. *Journal of Development Economics*, 57:233–257.
- Bouza, S. and Turnovsky, S. (2012). The distributional consequences of foreign transfers: Do they reduce or exacerbate inequality? *Oxford Economic Papers*, 64(4):702–735.

- Box, G. and Cox, D. (1964a). An analysis of transformations. *Journal of the Royal Statistical Society. Series B (Methodological)*, 26:211–252.
- Box, G. and Cox, D. (1964b). An analysis of transformations. *Journal of the Royal Statistical Society. Series B (Methodological)*, 26:211–252.
- Boyce, J. (1994). Inequality as a cause of environmental degradation. *Ecological Economics*, 11:169 – 178.
- Boyer, R. (1977). Commercial policy under alternative exchange rate regimes. *Canadian Journal of Economics*, 19:218–232.
- Breen, R. and García-Peñalosa, C. (2005). Income inequality and macroeconomic volatility: An empirical investigation. *Review of Development Economics*, 9:380–398.
- Brock, P. and Turnovsky, S. (1993). The growth and welfare consequences of differential tariffs. *International Economic Review*, 34:765–794.
- Brock, P. and Turnovsky, S. (1994). The dependent-economy model with both traded and nontraded capital goods. *Review of International Economics*, 2(3):306–325.
- Bruno, M. (1982). Adjustment and structural change under supply shocks. *Scandinavian Journal of Economics*, 84:199–221.
- Callander, S. (2007). Bandwagons and momentum in sequential voting. *The Review of Economic Studies*, 74:653–684.
- Callander, S. (2008). Majority rule when voters like to win. *Games and Economic Behavior*, 64:393–420.
- Carpenter, S. and Rodgers, W. (2004). The disparate labor market impacts of monetary policy. *Journal of Policy Analysis and Management*, 23:813–830.
- Caselli, F. and Ventura, J. (2000). A representative consumer theory of distribution. *The American Economic Review*, 90:909–926.

- Chan, K. (1978). The employment effects of tariffs under free exchange rate regime. *Journal of International Economics*, 8:414–424.
- Chinn, M. and Ito, H. (2008). A new measure of financial openness. *Journal of Comparative Policy Analysis: Research and Practice*, 10:309–322.
- Compte, O. and Jehiel, P. (2010). Bargaining and majority rules: A collective search perspective. *Journal of Political Economy*, 118:189–221.
- Dasgupta, S., Laplante, B., Wang, H., and Wheeler, D. (2002). Confronting the environmental kuznets curve. *The Journal of Economic Perspectives*, 16:147–168.
- Deininger, K. and Squire, L. (1997). Economic growth and income inequality: Reexamining the links. *Finance & Development*, 34:38–41.
- Dollar, D. and Kraay, A. (2002). Growth is good for the poor. *Journal of Economic Growth*, 7:195–225.
- Dollar, D. and Kraay, A. (2004). Trade, growth, and poverty. *The Economic Journal*, 114(493):F22–F49.
- Dornbusch, R. (1980). *Open economy macroeconomics*. Basic Books, New York, NY.
- Duarte, R., Pinilla, V., and Serrano, A. (2013). Is there an environmental kuznets curve for water use? a panel smooth transition regression approach. *Economic Modelling*, 31:518–527.
- Dunbar, R. (2006). We believe. *New Scientist*, 2536:30–33.
- Easterly, W., Kremer, M., Pritchett, L., and Summers, L. (1993). Good policy or good luck? *Journal of Monetary Economics*, 32:459–483.
- Eaton, J. and Gersovitz, M. (1981). Debt with potential repudiation: Theoretical and empirical analysis. *The Review of Economic Studies*, 48:289–309.

- Edwards, S. (1997). Trade policy, growth, and income distribution. *The American Economic Review*, 87:205–210.
- Eichengreen, B. (1981). A dynamic model of tariffs, output, and employment under flexible exchange rate. *Journal of International Economics*, 11:341–359.
- Eisenberger, N. and Cole, S. (2012). Social neuroscience and health: Neurophysiological mechanisms linking social ties with physical health. *Nature Neuroscience*, 15:669–674.
- Eisenberger, N., Lieberman, M., and Williams, K. (2003). Does rejection hurt? An fMRI study of social exclusion. *Science*, 302:290–292.
- Engel, C. and Kletzer, K. (1989). Saving and investment in an open economy with nontraded goods. *International Economic Review*, 30:735–752.
- Engel, C. and Kletzer, K. (1990). Tariffs and savings in a model with new generations. *Journal of International Economics*, 29:71–91.
- Estevadeordal, A. and Taylor, A. (2013). Is the Washington consensus dead? Growth, openness, and the Great Liberalization, 1970s-2000s. *Review of Economics and Statistics*, 95:1669–1690.
- Fajgelbaum, P., Grossman, G., and Helpman, E. (2011). Income distribution, product quality, and international trade. *Journal of Political Economy*, 119(4):721–765.
- Feddersen, T. and Pesendorfer, W. (1998). Convicting the innocent: The inferiority of unanimous jury verdicts under strategic voting. *American Political Science Review*, 92:23–35.
- Fender, J. and Yip, C. (2000). Tariffs and exchange rate dynamics redux. *Journal of International Money and Finance*, 19:633–655.
- Forbes, K. (2000). A reassessment of the relationship between inequality and growth. *The American Economic Review*, 90:869–887.

- Fouquau, J., Hurlin, C., and Rabaud, I. (2008). The Feldstein-Horioka puzzle: A panel smooth transition regression approach. *Economic Modelling*, 25:284–299.
- Freedom House, T. (2015). *Freedom in the World 2015*. Freedom House, Washington, D.C.
- Galbraith, J. (1998). With economic inequality for all: In the absence of policies insuring fairness, it's soon every man for himself. *The Nation*, 267:24–28.
- García-Peñalosa, C. and Turnovsky, S. (2006). Growth and income inequality: A canonical model. *Economic Theory*, 28:25–49.
- Gardner, G. and Kimbrough, K. (1989). Tariffs, interest rates and the trade balance in the world economy. *Journal of International Economics*, 27:91–110.
- Goldberg, P. K. and Pavcnik, N. (2007). Distributional effects of globalization in developing countries. *Journal of Economic Literature*, 45:39–82.
- González, A., Teräsvirta, T., and van Dijk, D. (2005). Panel smooth transition regression models. SSE/EFI Working Paper Series in Economics and Finance 604, Stockholm School of Economics.
- Gorman, W. (1953). Community preference fields. *Econometrica*, 21:63–80.
- Griliches, Z. and Hausman, J. (1986). Errors in variables in panel data. *Journal of econometrics*, 31:93–118.
- Grossman, G. and Helpman, E. (2014). Growth, trade, and inequality. Working Paper 20502, National Bureau of Economic Research.
- Grossman, G. and Krueger, A. (1993). Environmental impacts of a north american free trade agreement. in the mexico-us free trade agreement”.
- Grossman, G. and Krueger, A. (1995). Economic growth and the environment. *The Quarterly Journal of Economics*, 110:353–377.

- Guilló, M. and Perez-Sebastian, F. (2007). The curse and blessing of fixed specific factors in small-open economies. *Journal of Development Economics*, 82(1):58–78.
- Hansen, B. (1999). Threshold effects in non-dynamics panels: Estimation, testing, and inference. *Journal of Econometrics*, 93:345–368.
- Hansen, L. (1982). Large sample properties of Generalized Method of Moments estimators. *Econometrica*, 50:1029–1054.
- Harrison, A. and Hanson, G. (1999). Who gains from trade reform? Some remaining puzzles. *Journal of Development Economics*, 59:125–154.
- Heap, S. and Zizzo, D. (2009). The value of groups. *The American Economic Review*, 99:295–323.
- Heerink, N., Mulatu, A., and Bulte, E. (2001). Income inequality and the environment: aggregation bias in environmental kuznets curves. *Ecological Economics*, 38:359–367.
- Huang, W., Lee, G., and Wu, C. (2008). Ghg emissions, gdp growth and the kyoto protocol: A revisit of environmental kuznets curve hypothesis. *Energy Policy*, 36:239–247.
- Huggett, M. (1993). The risk-free rate in heterogeneous-agent incomplete-insurance economies. *Journal of Economic Dynamics and Control*, 17(5-6):953–969.
- Hwang, Y. and Turnovsky, S. (2013). Exchange-rate pass-through and the effects of tariffs on economic performance and welfare. *Journal of International Money and Finance*, 33:81–102.
- Jaumotte, F., Lall, S., and Papageorgiou, C. (2013). Rising income inequality: Technology, or trade and financial globalization? *IMF Economic Review*, 61:271–309.

- Jorgenson, D. W. and Vu, K. (2005). Information technology and the world economy. *Scandinavian Journal of Economics*, 107(4):631–650.
- Jorgenson, D. W. and Vu, K. (2007). Information technology and the world growth resurgence. *German Economic Review*, 8(2):125–145.
- Katsimi, M. and Moutos, T. (2010). Review of international economics. *Inequality and the relative reliance on tariffs*, 18:121–137.
- Keane, M. and Rogerson, R. (2012). Micro and macro labor supply elasticities: A reassessment of conventional wisdom. *Journal of Economic Literature*, 50:464–476.
- Kempf, H. and Rossignol, S. (2007). Is inequality harmful for the environment in a growing economy? *Economics & Politics*, 19:53–71.
- Kimbrough, K. (1982). Real disturbances, the current account, and the exchange rate: The case of the tariff. *Journal of International Economics*, 13:231–256.
- Kleibergen, F. and Paap, R. (2006). Generalized reduced rank tests using the singular value decomposition. *Journal of Econometrics*, 133:97–126.
- Krugman, P. (1982). The macroeconomics of protection with a floating exchange rate. *Carnegie-Rochester Conference Series on Public Policy*, 16:141–182.
- Krusell, P. and Smith, A. (1998). Income and wealth heterogeneity in the macroeconomy. *Journal of Political Economy*, 106(5):867–896.
- Kuznets, S. (1955). Economic growth and income inequality. *The American Economic Review*, 45:1–28.
- Lane, P. and Milesi-Ferretti, G. (2007). The external wealth of nations mark ii: Revised and extended estimates of foreign assets and liabilities, 1970-2004. *Journal of International Economics*, 73:223–250.

- Lavy, V., Ebenstein, A., and Roth, S. (2014). The impact of short term exposure to ambient air pollution on cognitive performance and human capital formation. Working Paper 20648, National Bureau of Economic Research.
- Lehmann, S. and O'Rourke, K. (2011). The structure of protection and growth in the late nineteenth century. *Review of Economics and Statistics*, 93:606–616.
- Levy, G. (2007). Decision making in committees: Transparency, reputation, and voting rules. *The American Economic Review*, 97:150–168.
- Li, H., Squire, L., and Zou, H. (1998). Explaining international and intertemporal variations in income inequality. *The Economic Journal*, 108:26–43.
- Li, H. and Zou, H. (1998). Income inequality is not harmful for growth: Theory and evidence. *Review of Development Economics*, 2(3):318–334.
- Lim, G. and McNelis, P. D. (2014). Income inequality, trade and financial openness. International Monetary Fund.
- Lindbeck, A. (1997). Incentives and social norms in household behavior. *The American Economic Review*, 87:370–377.
- López-Villavicencio, A. and Mignon, V. (2011). On the impact of inflation on output growth: Does the level of inflation matter? *Journal of Macroeconomics*, 33:455–464.
- Lucas, R. (1990). Supply-side economics: An analytical review. *Oxford Economic Papers*, 42:293–316.
- Magnani, E. (2000). The environmental kuznets curve, environmental protection policy and income distribution. *Ecological Economics*, 32:431 – 443.
- Maslow, A. (1943). A theory of human motivation. *Psychological Review*, 50:370–396.
- Maslow, A. (1968). *Toward a psychology of being*. Start Publishing LLC, New York: Van Nostrand.

- Max-Neef, M. (1995). Economic growth and quality of life: A threshold hypothesis. *Ecological Economics*, 15:115–118.
- Milanovic, B. (2014). *All the Ginis Database*. World Bank Development Research Program, Washington D.C.
- Milanovic, B. and Squire, L. (2005). Does tariff liberalization increase wage inequality? Some empirical evidence. *National Bureau of Economic Research*, Working Paper No. 11046.
- Moldovanu, B. and Shi, X. (2013). Specialization and partisanship in committee search. *Theoretical Economics*, 8:751–774.
- Mundell, R. (1961). Flexible exchange rates and employment policy. *Canadian Journal of Economics and Political Science*, 27:509–517.
- Narayan, P. and Narayan, S. (2010). Carbon dioxide emissions and economic growth: Panel data evidence from developing countries. *Energy Policy*, 38:661–666.
- Nickell, S. (1981). Biases in dynamic models with fixed effects. *Econometrica*, 49:1417–1426.
- Obstfeld, M. and Rogoff, K. (1995). Exchange rate dynamics Redux. *Journal of Political Economy*, 103:624–660.
- Obstfeld, M. and Rogoff, K. (2000). New directions for stochastic open economy models. *Journal of International Economics*, 50:117–153.
- Osang, T. and Pereira, A. (1996). Import tariffs and growth in a small open economy. *Journal of Public Economics*, 60(1):45–71.
- Osang, T. and Turnovsky, S. (2000). Differential tariffs, growth, and welfare in a small open economy. *Journal of Development Economics*, 62(2):315–342.
- Ostry, J. (1991). Trade liberalization in developing countries: Initial trade distortions and imported intermediate inputs. *IMF Staff Papers*, 38:447–479.

- Ottaviani, M. and Sørensen, P. (2001). Information aggregation in debate: Who should speak first? *Journal of Public Economics*, 81:393–421.
- Oxborrow, D. and Turnovsky, S. (2015). Closing the small open economy model: A demographic approach. Working paper, University of Washington.
- Perotti, R. (1996). Growth, income distribution and democracy: What the data say? *Journal of Economic Growth*, 1:149–187.
- Persico, N. (2004). Committee design with endogenous information. *The Review of Economic Studies*, 71:165–191.
- Persson, T. and Tabellini, G. (1994). Is inequality harmful for growth? *The American Economic Review*, 84(3):600–621.
- Piketty, T. (2011). On the long-run evolution of inheritance: France 1820-2050. *The Quarterly Journal of Economics*, 61:1071–1131.
- Piketty, T. and Goldhammer, A. (2014). *Capital in the Twenty-first Century*. The Belknap Press of Harvard University Press, Cambridge, Massachusetts.
- Quah, D. (2003). One third of the World’s growth and Inequality. *in T. Eicher and S.J. Turnovsky (eds), Growth and Inequality: Issues and Policy Implications*, Cambridge: MIT Press.
- Ramsey, F. (1927). A Contribution to the Theory of Taxation. *The Economic Journal*, 37:47–61.
- Ravallion, M., Heil, M., and Jalan, J. (2000). Carbon emissions and income inequality. *Oxford Economic Papers*, 52:651–669.
- Rojas-Vallejos, J. and Turnovsky, S. (2015). The consequences of tariff reduction for economic activity and inequality. *Open Economies Review*, 26:601–631.
- Roodman, D. (2009). How to do xtabond2: An introduction to difference and system gmm in stata. *Stata Journal*, 9:86–136.

- Ryan, R. and Deci, E. (2000). Self-determination theory and the facilitation of intrinsic motivation, social development, and well-being. *American Psychologist*, 55:68–78.
- Sala-i-Martin, X. (2006). The world distribution of income: Falling poverty and Convergence, period. *Quarterly Journal of Economics*, 121:351–397.
- Samuelson, P. (1964). Theoretical notes on trade problems. *The Review of Economics and Statistics*, 46:145–154.
- Savvides, A. (1998). Trade policy and income inequality: New evidence. *Economics Letters*, 61:365–372.
- Schmitt-Grohé, S. and Uribe, M. (2003). Closing small open economy models. *Journal of International Economics*, 61:163–185.
- Sen, P. and Turnovsky, S. (1989). Tariffs, capital accumulation, and the current account in a small open economy. *International Economic Review*, 30:881–831.
- Sharma, S. (2011). Determinants of carbon dioxide emissions: Empirical evidence from 69 countries. *Applied Energy*, 88:376–382.
- Solt, F. (2009). Standardizing the world income inequality database. *Social Science Quarterly*, 90:231–242.
- Sorger, G. (2000). Income and wealth distribution in a simple growth model. *Economic Theory*, 16:23–42.
- Stewart, F. and Berry, A. (2000). Globalization, liberalization, and inequality. Real causes: Expectations and experience. *Challenge*, 43:44–92.
- Stiglitz, J. (1974). The Cambridge-Cambridge controversy in the theory of capital; A view from New Haven: A review article. *Journal of Political Economy*, 82:893–903.
- Stiglitz, J. (2013). *The price of inequality: How today's divided society endangers our future*. W.W. Norton & Company, Inc., New York, NY.

- Swan, T. (1960). Economic control in a dependent economy. *Economic Record*, 36:51–66.
- Sylwester, K. (2002). Can education expenditures reduce income inequality? *Economics of Education Review*, 21:43–52.
- Taylor, L., Rezai, A., and Foley, D. (2015). An integrated approach to climate change, income distribution, employment, and economic growth. *Ecological Economics*.
- Teräsvirta, T. (1994). Specification, estimation, and evaluation of smooth transition autoregressive models. *Journal of the American Statistical Association*, 89:208–218.
- Thanh, S. (2015). Threshold effects of inflation on growth in the asean-5 countries: A panel smooth transition regression approach. *Journal of Economics, Finance and Administrative Science*, 20:41–48.
- Tol, R. (2002). Estimates of the damage costs of climate change. part 1: Benchmark estimates. *Environmental and Resource Economics*, 21:47–73.
- Torras, M. and Boyce, J. (1998). Income, inequality, and pollution: a reassessment of the environmental kuznets curve. *Ecological Economics*, 25:147–160.
- Turnovsky, S. (1985). Domestic and foreign disturbances in an optimizing model of exchange-rate determination. *Journal of International Money and Finance*, 4(1):151–171.
- Turnovsky, S. (1997). *International Macroeconomic Dynamics*. The MIT Press, Cambridge, Massachusetts.
- Turnovsky, S. (2002). Knife-edge conditions and the macro dynamics of small open economies. *Macroeconomic Dynamics*, 6:307–335.

- Turnovsky, S. and García-Peñalosa, C. (2008). Distributional dynamics in a neo-classical growth model: The role of elastic labor supply. *Journal of Economic Dynamics and Control*, 32:1399–1431.
- van Wincoop, E. (1993). Structural adjustment and the construction sector. *European Economic Review*, 37:177–201.
- Voitchovsky, S. (2005). Does the profile of income inequality matter for economic growth? *Journal of Economic Growth*, 10:273–296.
- Wacziarg, R. and Welch, K. (2008). Trade liberalization and growth: New evidence. *The World Bank Economic Review*, 22:187–231.
- Windmeijer, F. (2005). A finite sample correction for the variance of linear efficient two-step GMM estimators. *Journal of Econometrics*, 126:25–51.

Appendix A

TECHNICAL DETAILS, CHAPTER 2

A.1 Dynamics of Aggregate Economy

Linearizing (2.15)-(2.19) around their steady state, (2.20), we may write the dynamics as

$$\begin{pmatrix} \dot{K}(t) \\ \dot{B}(t) \\ \dot{s}(t) \\ \dot{L}(t) \\ \dot{\tau}(t) \end{pmatrix} = \begin{pmatrix} a_{11} & a_{12} & a_{13} & a_{14} & 0 \\ a_{21} & a_{22} & a_{23} & a_{24} & a_{25} \\ a_{31} & a_{32} & a_{33} & a_{34} & 0 \\ a_{41} & a_{42} & a_{43} & a_{44} & a_{45} \\ 0 & 0 & 0 & 0 & -\lambda \end{pmatrix} \cdot \begin{pmatrix} K(t) - \tilde{K} \\ B(t) - \tilde{B} \\ s(t) - \tilde{s} \\ L(t) - \tilde{L} \\ \tau(t) - \tilde{\tau} \end{pmatrix} \quad (\text{A.1})$$

where a_{ij} is the corresponding partial derivative evaluated at steady state. Since these are easily computed, there is no need to report them. This is a fifth order system with three sluggish variables, $K(t)$, $B(t)$, and $\tau(t)$ and two jump variables $s(t)$ and $L(t)$. It will have a unique stable adjustment path if and only if there are three stable eigenvalues: (i) $-\lambda$ and (ii) μ_1, μ_2 , where $\mu_1 < 0, \mu_2 < 0$ are the two negative roots to the internal system specified by the sub-matrix $A = (a_{ij})$, $i = 1, \dots, 4, j = 1, \dots, 4$. In this case the system is a saddlepoint, with the stable solution being given by

$$K(t) - \tilde{K} = A_1 e^{\mu_1 t} + A_2 e^{\mu_2 t} + \pi_1 (\tau_0 - \tilde{\tau}) e^{-\lambda t} \quad (\text{A.2a})$$

$$B(t) - \tilde{B} = A_1 \kappa_{21} e^{\mu_1 t} + A_2 \kappa_{22} e^{\mu_2 t} + \pi_2 (\tau_0 - \tilde{\tau}) e^{-\lambda t} \quad (\text{A.2b})$$

$$s(t) - \tilde{s} = A_1 \kappa_{31} e^{\mu_1 t} + A_2 \kappa_{32} e^{\mu_2 t} + \pi_3 (\tau_0 - \tilde{\tau}) e^{-\lambda t} \quad (\text{A.2c})$$

$$L(t) - \tilde{L} = A_1 \kappa_{41} e^{\mu_1 t} + A_2 \kappa_{42} e^{\mu_2 t} + \pi_4 (\tau_0 - \tilde{\tau}) e^{-\lambda t} \quad (\text{A.2d})$$

where $(1, \kappa_{2j}, \kappa_{3j}, \kappa_{4j})'$ for $j = 1, 2$ is the normalized eigenvector associated with the stable eigenvalue μ_j and $\pi_i, i = 1, \dots, 4$ are the solutions to:

$$\begin{pmatrix} a_{11} + \lambda & a_{12} & a_{13} & a_{14} \\ a_{21} & a_{22} + \lambda & a_{23} & a_{24} \\ a_{31} & a_{32} & a_{33} + \lambda & a_{34} \\ a_{41} & a_{42} & a_{43} & a_{44} + \lambda \end{pmatrix} \cdot \begin{pmatrix} \pi_1 \\ \pi_2 \\ \pi_3 \\ \pi_4 \end{pmatrix} = \begin{pmatrix} 0 \\ -a_{25} \\ 0 \\ -a_{45} \end{pmatrix} \quad (\text{A.3})$$

The arbitrary constants, A_1, A_2 are obtained from initial conditions on K_0, B_0 namely

$$A_1 + A_2 = (K_0 - \tilde{K}) - \pi_1(\tau_0 - \tilde{\tau}) \quad (\text{A.4a})$$

$$A_1\kappa_{21} + A_2\kappa_{22} = (B_0 - \tilde{B}) - \pi_2(\tau_0 - \tilde{\tau}) \quad (\text{A.4b})$$

The system of equations (A.2a)-(A.4b) provides the basis for the analysis of the transitional dynamics. With A_1, A_2 determined by (A.4a) and (A.4b), the initial values of $s(0), L(0)$ are

$$s(0) = \tilde{s} + A_1\kappa_{31} + A_2\kappa_{32} + \pi_3(\tau_0 - \tilde{\tau})$$

$$L(0) = \tilde{L} + A_1\kappa_{41} + A_2\kappa_{42} + \pi_4(\tau_0 - \tilde{\tau})$$

Having obtained $\pi_1, \dots, \pi_4, A_1, A_2$ the transitional dynamics follow (A.2a)-(A.2d). The case that τ is adjusted fully at time 0 is obtained by letting $\lambda \rightarrow \infty$ in this case the corresponding solution is

$$K(t) - \tilde{K} = A'_1 e^{\mu_1 t} + A'_2 e^{\mu_2 t} \quad (\text{A.2a}')$$

$$B(t) - \tilde{B} = A'_1 \kappa_{21} e^{\mu_1 t} + A'_2 \kappa_{22} e^{\mu_2 t} \quad (\text{A.2b}')$$

$$s(t) - \tilde{s} = A'_1 \kappa_{31} e^{\mu_1 t} + A'_2 \kappa_{32} e^{\mu_2 t} \quad (\text{A.2c}')$$

$$L(t) - \tilde{L} = A'_1 \kappa_{41} e^{\mu_1 t} + A'_2 \kappa_{42} e^{\mu_2 t} \quad (\text{A.2d}')$$

where

$$A'_1 + A'_2 = (K_0 - \tilde{K}) \quad (\text{A.4a}')$$

$$A'_1 \kappa_{21} + A'_2 \kappa_{22} = (B_0 - \tilde{B}) \quad (\text{A.4b}')$$

A.2 Derivation of Equation (20)

From equation (2.24), we have

$$\dot{v}_j = \frac{1}{V} \left([C - T - w(K, L)L](v_j - 1) + (1 + \eta)(1 - \varphi_j)C \right) \quad (\text{A.5})$$

where $T = \frac{\tau(1-\theta)}{1+\tau}C$ so that $C - T = \left(\frac{1+\tau\theta}{1+\tau}\right)C$. Substituting these expressions into (2.24):

$$\dot{v}_j = \frac{1}{V} \left(\left[\left(\frac{1+\tau\theta}{1+\tau} \right) C - w(K, L)L \right] (v_j - 1) + (1 + \eta)(1 - \varphi_j)C \right)$$

Linearizing this expression around $\tilde{v}_j, \tilde{C}, \tilde{K}, \tilde{L}, \tilde{\tau}$ yields the approximation

$$\begin{aligned} \dot{v}_j &= \frac{1}{\tilde{V}} \left[\left(\frac{1+\tau\theta}{1+\tau} \right) \tilde{C} - w(\tilde{K}, \tilde{L})\tilde{L} \right] (v_j - \tilde{v}_j) + \frac{1}{\tilde{V}} (1 + \eta)(1 - \varphi_j)(C - \tilde{C}) \quad (\text{A.6}) \\ &+ \frac{(\tilde{v}_j - 1)}{\tilde{V}} \left[\left(\frac{1+\tau\theta}{1+\tau} \right) (C - \tilde{C}) - \tilde{w}_K \tilde{L}(K - \tilde{K}) - (\tilde{w}_L \tilde{L} + \tilde{w})(L - \tilde{L}) - \tilde{C} \frac{(1-\theta)}{(1+\tilde{\tau})^2} (\tau - \tilde{\tau}) \right] \end{aligned}$$

From the steady-state to (2.24) we obtain

$$(1 + \eta)(1 - \varphi_j) = - \frac{(\tilde{C} - \tilde{T} - w(\tilde{K}, \tilde{L})\tilde{L})}{\tilde{C}} (\tilde{v}_j - 1) = -\beta \left(\frac{\tilde{V}}{\tilde{C}} \right) (\tilde{v}_j - 1) \quad (\text{A.7})$$

Using this relationship in (A.6) yields

$$\begin{aligned} \dot{v}_j &= \beta(v_j - \tilde{v}_j) + (\tilde{v}_j - 1) \left(\frac{\tilde{C}}{\tilde{V}} \left(\frac{1+\tau\theta}{1+\tau} \right) - \beta \right) \left(\frac{C - \tilde{C}}{\tilde{C}} \right) \quad (\text{A.8}) \\ &- \frac{(\tilde{v}_j - 1)}{\tilde{V}} \left[\tilde{w}_K \tilde{L}(K - \tilde{K}) + (\tilde{w}_L \tilde{L} + \tilde{w})(L - \tilde{L}) + \tilde{C} \frac{(1-\theta)}{(1+\tilde{\tau})^2} (\tau - \tilde{\tau}) \right] \end{aligned}$$

Using the steady-state equilibrium condition, $\tilde{C} = \beta\tilde{V} + \tilde{T} + \tilde{w}\tilde{L}$, we may write (A.8) in the form

$$\dot{v}_i = \beta(v_i - \tilde{v}_i) + \frac{\tilde{v}_i - 1}{\tilde{V}} \left[\tilde{w}\tilde{L} \left(\frac{C - \tilde{C}}{\tilde{C}} \right) - \tilde{w}_K \tilde{L}(K - \tilde{K}) - (\tilde{w}_L \tilde{L} + \tilde{w})(L - \tilde{L}) - \tilde{C} \frac{(1-\theta)}{(1+\tilde{\tau})^2} (\tau - \tilde{\tau}) \right] \quad (\text{A.9})$$

From $C = \frac{1}{\eta}w(K, L)(1 - L)$ we obtain

$$\frac{C - \tilde{C}}{\tilde{C}} = \frac{\tilde{w}_K}{\tilde{w}}(K - \tilde{K}) + \left(\frac{\tilde{w}_L}{\tilde{w}} - \frac{1}{1 - \tilde{L}} \right) (L - \tilde{L})$$

and substituting into (A.9) yields (2.27)

$$\dot{v}_j = \beta(v_j(t) - \tilde{v}_j) - \frac{(\tilde{v}_j - 1)}{\tilde{V}} \left[\left(\frac{\tilde{F}_L}{1 - \tilde{L}} \right) (L(t) - \tilde{L}) + \tilde{C} \frac{(1-\theta)}{(1+\tilde{\tau})^2} (\tau - \tilde{\tau}) \right] \quad (\text{A.10})$$

Appendix B

DATA, CHAPTER 3

B.1 Variables

Inequality. The income Gini data come from the *All The Ginis* (ATG) dataset compiled by Milanovic (2014). These consist only of the Gini coefficients that have been calculated from actual households surveys and it contains Ginis estimated from expenditures surveys and income surveys at the national level. It includes no Gini estimates produced by regressions or imputations. Milanovic compiles these data from nine different sources: the Luxembourg Income Study (LIS), the Socio-Economic Database for Latin America and the Caribbean (SEDLAC), the Survey of Income and Living Condition (SILC), the World Banks Eastern Europe and Central Asia (ECA), the World Income Distribution (WYD), the PovcalNet from the World Bank, the World Institute for Development Research (WIDER), the Economic Commission for Latin America and the Caribbean (CEPAL), and Individual data sets (INDIE). Notice that he excludes data from Deininger and Squire (1997) because they have been either superseded or included in WIDER. In order to analyze income transfers between different groups, we also collect data on income shares by quintiles. We use the World Income Inequality Dataset (WIID) provided by the United Nations, version 3.0.b. As a robustness check of our findings we also use the dataset provided by Solt (2009) that uses imputed data standardized with the LIS methodology.

Trade. Data on tariff rates are obtained from the Data on Trade and Import Barriers database at the World Bank (2015) compiled by Francis K.T. Ng consisting on 170 countries for the period 1981 to 2010.

International Finance. We use the data provided by [Lane and Milesi-Ferretti \(2007\)](#).

Financial Development. We use the data provided by the World Bank in the Global Financial Development Database (GFDD) by [Cinak, Demirguc-Kunt, Feyen and Levine \(2012\)](#).

Education. The data on educational attainment are obtained from [Barro and Lee \(2001\)](#) and [Barro and Lee \(2013\)](#). We pay particular attention to the impact on inequality of the share of the population with at least secondary and the average years of education as has been widely discussed in [Jaumotte et al. \(2013\)](#) and [Li et al. \(1998\)](#).

Political System. The information about the political system is obtained from two different sources. We obtain data on political rights and civil liberties from the Freedom House (2015). The Freedom House scale ranges from 1.0 (free) to 7.0 (not free).

Other Macroeconomic Variables. Data on unemployment and share of employment by sectors and added value by sectors are obtained from the World Development Indicators (WDI) at the World Bank. Relative labor productivity is computed using the standard definitions. Data on the contribution of Information and Communications Technologies (ICTs) capital services to GDP growth are obtained from [Jorgenson and Vu \(2005\)](#) and [Jorgenson and Vu \(2007\)](#).

Countries. We use the division of territories and income provided by the World Bank. The world is divided in eight regions: Latin America and the Caribbean, Sub-Saharan Africa, Central and Eastern Europe, Commonwealth of Independent States, Developing Asia, Middle East and North Africa, North America, and Western Europe. Income groups are divided in four groups: low income, \$610 or less (L); low-middle income, \$611-\$2,465 (LM); upper-middle income, \$2,466-\$7,620

(UM); and high income, \$7,621 or more (H). We use the income classification assigned by the World Bank in year 1990 in dollars of that year.

The countries involved in this empirical study are the following. The number of observations available on income inequality and tariffs are given in the parentheses. Algeria (1), Angola (1), Argentina (23), Australia (9), Azerbaijan (3), Barbados (1), Belarus (2), Belize (2), Bolivia (14), Brazil (27), Bulgaria (12), Canada (9), Chile (19), China (21), Colombia (21), Costa Rica (18), Croatia (2), Cyprus (2), Czech Republic (8), Dominican Republic (11), Ecuador (15), Egypt (1), El Salvador (18), Estonia (9), Gambia (1), Guatemala (8), Guyana (1), Haiti (1), Honduras (12), Hungary (11), Iceland (4), Israel (7), Jamaica (5), Japan (7), Jordan (1), South Korea (8), Latvia (6), Lithuania (2), Macedonia (1), Malaysia (6), Mauritania (1), Mexico (13), Namibia (1), Nepal (1), New Zealand (4), Nicaragua (4), Nigeria (1), Norway (9), Panama (11), Paraguay (14), Peru (16), Poland (15), Romania (8), Russia (14), Serbia (4), Singapore (7), Slovak Republic (7), Slovenia (4), South Africa (3), Sri Lanka (2), Suriname (1), Switzerland (4), Taiwan (16), Tanzania (1), Trinidad y Tobago (2), Tunisia (1), Turkey (2), Uganda (1), Ukraine (1), United States (22), Uruguay (17), Uzbekistan (2), and Venezuela (18).

B.2 Descriptive Statistics

Table A.1: Summary Descriptive Statistics

		Mean	Std. Dev.	Min	Max	Observations
Gini	overall	44.0	10.9	17.5	69.8	N = 557
	between		11.1	19.1	66.4	n = 73
	within		3.0	32.1	58.4	T = 7.63
Tariff Rate	overall	11.2	8.5	0	51.0	N = 557
	between		6.5	0	32.6	n = 73
	within		6.0	-5.3	44.1	T = 7.63

Notes: Gini coefficient in units [0,100] and tariff rate in percentage points.

Table A.2: Summary for Income Share by Quintiles

		Mean	Std. Dev.	Min	Max	Observations
Q1	overall	5.94	2.46	0.90	10.92	N = 184
	between		2.64	1.44	10.16	n = 28
	within		0.58	3.72	7.97	T = 6.6
Q2	overall	10.67	2.80	3.59	15.22	N = 184
	between		3.13	3.59	14.75	n = 28
	within		0.63	8.53	12.36	T = 6.6
Q3	overall	15.03	2.55	6.38	18.60	N = 184
	between		3.01	6.38	18.19	n = 28
	within		0.61	12.63	16.73	T = 6.6
Q4	overall	21.37	1.77	13.97	24.41	N = 184
	between		2.15	13.97	23.62	n = 28
	within		0.63	17.13	23.03	T = 6.6
Q5	overall	46.98	9.09	33.43	74.54	N = 184
	between		10.48	34.36	74.54	n = 28
	within		2.08	40.95	55.30	T = 6.6

Notes: Variables in units of percentage points.

Appendix C

TECHNICAL DETAILS, CHAPTER 4

C.1 Properties of the Short Run

Using the static efficiency conditions and the market clearing conditions we obtain the following explicit choice functions (ECFs). For consumption we get,

$$C_T^j = C_T^j(\lambda_j, p; \tau_e) \quad (\text{C.1a})$$

$$C_N^j = C_N^j(\lambda_j, p; \tau_e) \quad (\text{C.1b})$$

$$C_F^j = C_F^j(\lambda_j, p; \tau_e) \quad (\text{C.1c})$$

For the sectoral intensities we get,

$$s_T = s_T(p, S, B; \tau_e) \quad ; \quad e_T = e_T(p, S, B; \tau_e) \quad (\text{C.2a})$$

$$s_N = s_N(p, S, B; \tau_e) \quad ; \quad e_N = e_N(p, S, B; \tau_e) \quad (\text{C.2b})$$

For marginal productivities we obtain,

$$w = w(p, S, B; \tau_e) \quad (\text{C.3a})$$

$$r_s = r_s(p, S, B; \tau_e) \quad (\text{C.3b})$$

$$r_e = r_e(p, S, B; \tau_e) \quad (\text{C.3c})$$

From the market clearing conditions we get,

$$L_T = L_T(p, S, B; \tau_e) \quad (\text{C.4a})$$

$$E = E(p, S, B; \tau_e) \quad (\text{C.4b})$$

Last, for the sectoral productions we obtain,

$$Y_T = Y_T(p, S, B; \tau_e); \quad Y_N = Y_N(p, S, B; \tau_e) \quad (\text{C.5})$$

We will need the partial derivatives of s_T, e_T, s_N and e_N with respect to p, S, B and τ_e . To obtain them, we totally differentiate equations (4.27a) to (4.27d) shown below,

$$\begin{aligned} f_s(s_T, e_T) &= ph_s(s_N, e_N) \\ f_e(s_T, e_T) &= \left[i \left(\frac{B}{pS} \right) + \delta_E \right] (1 + \tau_e) + \nu_e(\tau_e - \tilde{\tau}_e) \\ ph_e(s_N, e_N) &= \left[i \left(\frac{B}{pS} \right) + \delta_E \right] (1 + \tau_e) + \nu_e(\tau_e - \tilde{\tau}_e) \\ f(s_T, e_T) - s_T f_s(s_T, e_T) - e_T f_e(s_T, e_T) &= p [h(s_N, e_N) - s_N h_s(s_N, e_N) - e_N h_e(s_N, e_N)] \end{aligned}$$

This procedure yields to,

$$\begin{aligned} & \begin{bmatrix} f_{ss} & f_{se} & -ph_{ss} & -ph_{se} \\ f_{es} & f_{ee} & 0 & 0 \\ 0 & 0 & ph_{es} & ph_{ee} \\ -(s_T f_{ss} + e_T f_{es}) & -(s_T f_{se} + e_T f_{ee}) & ps_N h_{ss} + pe_N h_{es} & ps_N h_{se} + pe_N h_{ee} \end{bmatrix} \cdot \begin{pmatrix} ds_T \\ de_T \\ ds_N \\ de_N \end{pmatrix} \\ &= \begin{pmatrix} h_s dp \\ -i'(\cdot) \frac{B}{pS} (1 + \tau_e) \frac{dS}{S} + i'(\cdot) \frac{(1+\tau_e)}{pS} dB - i'(\cdot) \frac{B}{pS} (1 + \tau_e) \frac{dp}{p} + (i(\cdot) + \delta_E + \nu_e) d\tau_e \\ -(1 + \tau_e) i'(\cdot) \frac{B}{pS} \frac{dS}{S} + \frac{(1+\tau_e)}{pS} i'(\cdot) dB - \left[h_e + (1 + \tau_e) i'(\cdot) \frac{B}{p^2 S} \right] dp + (i(\cdot) + \delta_E + \nu_e) d\tau_e \\ (h - s_N h_s - e_N h_e) dp \end{pmatrix} \end{aligned}$$

(i) Production

To determine $\frac{\partial s_T}{\partial S}$, we fix $dB = dp = d\tau_e = 0$. Thus,

$$\begin{aligned} & \begin{bmatrix} f_{ss} & f_{se} & -ph_{ss} & -ph_{se} \\ f_{es} & f_{ee} & 0 & 0 \\ 0 & 0 & ph_{es} & ph_{ee} \\ -(s_T f_{ss} + e_T f_{es}) & -(s_T f_{se} + e_T f_{ee}) & ps_N h_{ss} + pe_N h_{es} & ps_N h_{se} + pe_N h_{ee} \end{bmatrix} \cdot \begin{pmatrix} \partial s_T \\ \partial e_T \\ \partial s_N \\ \partial e_N \end{pmatrix} \\ &= \begin{pmatrix} 0 \\ -(1 + \tau_e) i'(\cdot) \frac{B}{pS^2} \partial S \\ -(1 + \tau_e) i'(\cdot) \frac{B}{pS^2} \partial S \\ 0 \end{pmatrix} \end{aligned}$$

This can be rewritten as,

$$\begin{pmatrix} \frac{\partial s_T}{\partial S} \\ \frac{\partial e_T}{\partial S} \\ \frac{\partial s_N}{\partial S} \\ \frac{\partial e_N}{\partial S} \end{pmatrix} = \begin{bmatrix} f_{ss} & f_{se} & -ph_{ss} & -ph_{se} \\ f_{es} & f_{ee} & 0 & 0 \\ 0 & 0 & ph_{es} & ph_{ee} \\ -(s_T f_{ss} + e_T f_{es}) & -(s_T f_{se} + e_T f_{ee}) & ps_N h_{ss} + pe_N h_{es} & ps_N h_{se} + pe_N h_{ee} \end{bmatrix}^{-1} \cdot \begin{pmatrix} 0 \\ -(1 + \tau_e) i'(\cdot) \frac{B}{pS^2} \\ -(1 + \tau_e) i'(\cdot) \frac{B}{pS^2} \\ 0 \end{pmatrix}$$

Using Cramer's rule, we compute the following determinants,

$$\begin{aligned} |\Omega| &= p^2 F(\cdot) H(\cdot) (s_T - s_N) \\ |\Omega_{s_T, S}| &= (1 + \tau_e) \left(\frac{B}{S^2} \right) pH(\cdot) i'(\cdot) [(e_T - e_N) f_{ee} + (s_T - s_N) f_{es}] \\ |\Omega_{e_T, S}| &= -(1 + \tau_e) \left(\frac{B}{S^2} \right) pH(\cdot) i'(\cdot) [(e_T - e_N) f_{es} + (s_T - s_N) f_{ss}] \\ |\Omega_{s_N, S}| &= (1 + \tau_e) \left(\frac{B}{S^2} \right) F(\cdot) i'(\cdot) [(e_T - e_N) h_{ee} + (s_T - s_N) h_{es}] \\ |\Omega_{e_N, S}| &= -(1 + \tau_e) \left(\frac{B}{S^2} \right) F(\cdot) i'(\cdot) [(e_T - e_N) h_{es} + (s_T - s_N) h_{ss}] \end{aligned}$$

where $F = f_{ss} f_{ee} - f_{es}^2$ and $H = h_{ss} h_{ee} - h_{es}^2$. All this yields to,

$$\begin{aligned} \frac{\partial s_T}{\partial S} &= (1 + \tau_e) \left(\frac{B}{pS^2} \right) \frac{i'(\cdot)}{F(\cdot)} \left[\frac{(e_T - e_N) f_{ee} + (s_T - s_N) f_{es}}{(s_T - s_N)} \right] \\ \frac{\partial e_T}{\partial S} &= -(1 + \tau_e) \left(\frac{B}{pS^2} \right) \frac{i'(\cdot)}{F(\cdot)} \left[\frac{(e_T - e_N) f_{es} + (s_T - s_N) f_{ss}}{(s_T - s_N)} \right] \\ \frac{\partial s_N}{\partial S} &= (1 + \tau_e) \left(\frac{B}{p^2 S^2} \right) \frac{i'(\cdot)}{H(\cdot)} \left[\frac{(e_T - e_N) h_{ee} + (s_T - s_N) h_{es}}{(s_T - s_N)} \right] \\ \frac{\partial e_N}{\partial S} &= -(1 + \tau_e) \left(\frac{B}{p^2 S^2} \right) \frac{i'(\cdot)}{H(\cdot)} \left[\frac{(e_T - e_N) h_{es} + (s_T - s_N) h_{ss}}{(s_T - s_N)} \right] \end{aligned}$$

Similarly, by fixing $dS = dp = d\tau_e = 0$, we obtain $\frac{\partial s_T}{\partial B}, \frac{\partial e_T}{\partial B}, \frac{\partial s_N}{\partial B}, \frac{\partial e_N}{\partial B}$ from the following matrix equation,

$$\begin{pmatrix} \frac{\partial s_T}{\partial B} \\ \frac{\partial e_T}{\partial B} \\ \frac{\partial s_N}{\partial B} \\ \frac{\partial e_N}{\partial B} \end{pmatrix} = \begin{bmatrix} f_{ss} & f_{se} & -ph_{ss} & -ph_{se} \\ f_{es} & f_{ee} & 0 & 0 \\ 0 & 0 & ph_{es} & ph_{ee} \\ -(s_T f_{ss} + e_T f_{es}) & -(s_T f_{se} + e_T f_{ee}) & p s_N h_{ss} + p e_N h_{es} & p s_N h_{se} + p e_N h_{ee} \end{bmatrix}^{-1} \cdot \begin{pmatrix} 0 \\ \frac{(1+\tau_e)}{pS} i'(\cdot) \\ \frac{(1+\tau_e)}{pS} i'(\cdot) \\ 0 \end{pmatrix}$$

Using Cramer's rule,

$$\begin{aligned} |\Omega_{s_T, B}| &= -(1 + \tau_e) \left(\frac{p}{S}\right) H(\cdot) i'(\cdot) [(e_T - e_N) f_{ee} + (s_T - s_N) f_{es}] \\ |\Omega_{e_T, B}| &= (1 + \tau_e) \left(\frac{p}{S}\right) H(\cdot) i'(\cdot) [(e_T - e_N) f_{es} + (s_T - s_N) f_{ss}] \\ |\Omega_{s_N, B}| &= -\frac{(1 + \tau_e)}{S} F(\cdot) i'(\cdot) [(e_T - e_N) h_{ee} + (s_T - s_N) h_{es}] \\ |\Omega_{e_N, B}| &= \frac{(1 + \tau_e)}{S} F(\cdot) i'(\cdot) [(e_T - e_N) h_{es} + (s_T - s_N) h_{ss}] \end{aligned}$$

This yields to,

$$\begin{aligned} \frac{\partial s_T}{\partial B} &= -\frac{(1 + \tau_e)}{pS} \frac{i'(\cdot)}{F(\cdot)} \left[\frac{(e_T - e_N) f_{ee} + (s_T - s_N) f_{es}}{(s_T - s_N)} \right] \\ \frac{\partial e_T}{\partial B} &= \frac{(1 + \tau_e)}{pS} \frac{i'(\cdot)}{F(\cdot)} \left[\frac{(e_T - e_N) f_{es} + (s_T - s_N) f_{ss}}{(s_T - s_N)} \right] \\ \frac{\partial s_N}{\partial B} &= -\frac{(1 + \tau_e)}{p^2 S} \frac{i'(\cdot)}{H(\cdot)} \left[\frac{(e_T - e_N) h_{ee} + (s_T - s_N) h_{es}}{(s_T - s_N)} \right] \\ \frac{\partial e_N}{\partial B} &= \frac{(1 + \tau_e)}{p^2 S} \frac{i'(\cdot)}{H(\cdot)} \left[\frac{(e_T - e_N) h_{es} + (s_T - s_N) h_{ss}}{(s_T - s_N)} \right] \end{aligned}$$

Fixing $dS = dB = d\tau_e = 0$, we obtain $\frac{\partial s_T}{\partial p}, \frac{\partial e_T}{\partial p}, \frac{\partial s_N}{\partial p}, \frac{\partial e_N}{\partial p}$ from the following matrix equation,

$$\begin{pmatrix} \frac{\partial s_T}{\partial p} \\ \frac{\partial e_T}{\partial p} \\ \frac{\partial s_N}{\partial p} \\ \frac{\partial e_N}{\partial p} \end{pmatrix} = \begin{bmatrix} f_{ss} & f_{se} & -ph_{ss} & -ph_{se} \\ f_{es} & f_{ee} & 0 & 0 \\ 0 & 0 & ph_{es} & ph_{ee} \\ -(s_T f_{ss} + e_T f_{es}) & -(s_T f_{se} + e_T f_{ee}) & ps_N h_{ss} + pe_N h_{es} & ps_N h_{se} + pe_N h_{ee} \end{bmatrix}^{-1} \cdot \begin{pmatrix} h_s \\ -(1 + \tau_e) \frac{B}{p^2 S} i'(\cdot) \\ -h_e - (1 + \tau_e) \frac{B}{p^2 S} i'(\cdot) \\ h - s_N h_s - e_N h_e \end{pmatrix}$$

Using Cramer's rule,

$$|\Omega_{s_T, p}| = (1 + \tau_e) \frac{B}{S} H(\cdot) i'(\cdot) [(e_T - e_N) f_{ee} + (s_T - s_N) f_{es}] - p^2 h(\cdot) H(\cdot) f_{ee}$$

$$|\Omega_{e_T, p}| = -(1 + \tau_e) \frac{B}{S} H(\cdot) i'(\cdot) [(e_T - e_N) f_{es} + (s_T - s_N) f_{ss}] + p^2 h(\cdot) H(\cdot) f_{es}$$

$$|\Omega_{s_N, p}| = (1 + \tau_e) \frac{B}{pS} F(\cdot) i'(\cdot) [(e_T - e_N) h_{ee} + (s_T - s_N) h_{es}] + pF(\cdot) [(h_e h_{es} - h_{ee} h_s)(s_T - s_N) - h_e h_{ss}]$$

$$|\Omega_{e_N, p}| = -(1 + \tau_e) \frac{B}{pS} F(\cdot) i'(\cdot) [(e_T - e_N) h_{es} + (s_T - s_N) h_{ss}] + pF(\cdot) [(h_{es} h_s - h_e h_{ss})(s_T - s_N) - h_e h_{ss}]$$

This yields to,

$$\frac{\partial s_T}{\partial p} = (1 + \tau_e) \frac{B}{p^2 S} \frac{i'(\cdot)}{F(\cdot)} \left[\frac{(e_T - e_N) f_{ee} + (s_T - s_N) f_{es}}{(s_T - s_N)} \right] - \frac{h}{F} \frac{f_{ee}}{(s_T - s_N)}$$

$$\frac{\partial e_T}{\partial p} = -(1 + \tau_e) \frac{B}{p^2 S} \frac{i'(\cdot)}{F(\cdot)} \left[\frac{(e_T - e_N) f_{es} + (s_T - s_N) f_{ss}}{(s_T - s_N)} \right] + \frac{h}{F} \frac{f_{es}}{(s_T - s_N)}$$

$$\frac{\partial s_N}{\partial p} = (1 + \tau_e) \frac{B}{p^2 S} \frac{i'(\cdot)}{pH} \left[\frac{(e_T - e_N) h_{ee} + (s_T - s_N) h_{es}}{(s_T - s_N)} \right] + \frac{1}{pH} \left[\frac{(h_e h_{es} - h_{ee} h_s)(s_T - s_N) - h_e h_{ss}}{(s_T - s_N)} \right]$$

$$\frac{\partial e_N}{\partial p} = -(1 + \tau_e) \frac{B}{p^2 S} \frac{i'(\cdot)}{pH} \left[\frac{(e_T - e_N) h_{es} + (s_T - s_N) h_{ss}}{(s_T - s_N)} \right] + \frac{1}{pH} \left[\frac{(h_s h_{es} - h_e h_{ss})(s_T - s_N) + h_e h_{ss}}{(s_T - s_N)} \right]$$

Fixing $dS = dB = dp = 0$, we obtain $\frac{\partial s_T}{\partial \tau_e}, \frac{\partial e_T}{\partial \tau_e}, \frac{\partial s_N}{\partial \tau_e}, \frac{\partial e_N}{\partial \tau_e}$ from the following matrix equation,

$$\begin{pmatrix} \frac{\partial s_T}{\partial \tau_e} \\ \frac{\partial e_T}{\partial \tau_e} \\ \frac{\partial s_N}{\partial \tau_e} \\ \frac{\partial e_N}{\partial \tau_e} \end{pmatrix} = \begin{bmatrix} f_{ss} & f_{se} & -ph_{ss} & -ph_{se} \\ f_{es} & f_{ee} & 0 & 0 \\ 0 & 0 & ph_{es} & ph_{ee} \\ -(s_T f_{ss} + e_T f_{es}) & -(s_T f_{se} + e_T f_{ee}) & p s_N h_{ss} + p e_N h_{es} & p s_N h_{se} + p e_N h_{ee} \end{bmatrix}^{-1} \cdot \begin{pmatrix} 0 \\ i(\cdot) + \delta_E + \nu_e \\ i(\cdot) + \delta_E + \nu_e \\ 0 \end{pmatrix}$$

Using Cramer's rule,

$$\begin{aligned} |\Omega_{s_T, \tau_e}| &= -p^2 H(\cdot)(i(\cdot) + \delta_E + \nu_e)[(e_T - e_N)f_{ee} + (s_T - s_N)f_{es}] \\ |\Omega_{e_T, \tau_e}| &= p^2 H(\cdot)(i(\cdot) + \delta_E + \nu_e)[(e_T - e_N)f_{es} + (s_T - s_N)f_{ss}] \\ |\Omega_{s_N, \tau_e}| &= -pF(\cdot)(i(\cdot) + \delta_E + \nu_e)[(e_T - e_N)h_{ee} + (s_T - s_N)h_{es}] \\ |\Omega_{e_N, \tau_e}| &= pF(\cdot)(i(\cdot) + \delta_E + \nu_e)[(e_T - e_N)h_{es} + (s_T - s_N)h_{ss}] \end{aligned}$$

This yields to,

$$\begin{aligned} \frac{\partial s_T}{\partial \tau_e} &= -\frac{(i(\cdot) + \delta_E + \nu_e)}{F} \left[\frac{(e_T - e_N)f_{ee} + (s_T - s_N)f_{es}}{(s_T - s_N)} \right] \\ \frac{\partial e_T}{\partial \tau_e} &= \frac{i(\cdot) + \delta_E + \nu_e}{F} \left[\frac{(e_T - e_N)f_{es} + (s_T - s_N)f_{ss}}{(s_T - s_N)} \right] \\ \frac{\partial s_N}{\partial \tau_e} &= -\frac{(i(\cdot) + \delta_E + \nu_e)}{pH} \left[\frac{(e_T - e_N)h_{ee} + (s_T - s_N)h_{es}}{(s_T - s_N)} \right] \\ \frac{\partial e_N}{\partial \tau_e} &= \frac{(i(\cdot) + \delta_E + \nu_e)}{pH} \left[\frac{(e_T - e_N)h_{es} + (s_T - s_N)h_{ss}}{(s_T - s_N)} \right] \end{aligned}$$

(ii) Sectoral Labor Allocations

Next, we want to determine the short-run effects on sectoral labor allocations. We do this because when linearizing the dynamic system, we need to know these partial derivatives. To obtain these derivatives, recall equation (4.30),

$$L_T = \frac{S - s_N}{s_T - s_N}$$

This expression yields the following partial derivatives,

$$\begin{aligned} \frac{\partial L_T}{\partial S} &= \frac{-1}{(s_T - s_N)} \left(-1 + L_T \frac{\partial s_T}{\partial S} + (1 - L_T) \frac{\partial s_N}{\partial S} \right) \\ \frac{\partial L_T}{\partial B} &= \frac{-1}{(s_T - s_N)} \left(L_T \frac{\partial s_T}{\partial B} + (1 - L_T) \frac{\partial s_N}{\partial B} \right) \\ \frac{\partial L_T}{\partial p} &= \frac{-1}{(s_T - s_N)} \left(L_T \frac{\partial s_T}{\partial p} + (1 - L_T) \frac{\partial s_N}{\partial p} \right) \\ \frac{\partial L_T}{\partial \tau_e} &= \frac{-1}{(s_T - s_N)} \left(L_T \frac{\partial s_T}{\partial \tau_e} + (1 - L_T) \frac{\partial s_N}{\partial \tau_e} \right) \end{aligned}$$

Further, equation (4.31),

$$E = L_T e_T + (1 - L_T) e_N$$

This yields to the following partial derivatives that will be used in the linearization of the dynamical system,

$$\begin{aligned} \frac{\partial E}{\partial S} &= (e_T - e_N) \frac{\partial L_T}{\partial S} + L_T \frac{\partial e_T}{\partial S} + (1 - L_T) \frac{\partial e_N}{\partial S} \\ \frac{\partial E}{\partial B} &= (e_T - e_N) \frac{\partial L_T}{\partial B} + L_T \frac{\partial e_T}{\partial B} + (1 - L_T) \frac{\partial e_N}{\partial B} \\ \frac{\partial E}{\partial p} &= (e_T - e_N) \frac{\partial L_T}{\partial p} + L_T \frac{\partial e_T}{\partial p} + (1 - L_T) \frac{\partial e_N}{\partial p} \\ \frac{\partial E}{\partial \tau_e} &= (e_T - e_N) \frac{\partial L_T}{\partial \tau_e} + L_T \frac{\partial e_T}{\partial \tau_e} + (1 - L_T) \frac{\partial e_N}{\partial \tau_e} \end{aligned}$$

The partial derivatives for $f(s_T, e_T)$ and $h(s_N, e_N)$ are given by,

$$\begin{aligned} \frac{\partial f}{\partial S} &= f_s \frac{\partial s_T}{\partial S} + f_e \frac{\partial e_T}{\partial S} \\ \frac{\partial f}{\partial B} &= f_s \frac{\partial s_T}{\partial B} + f_e \frac{\partial e_T}{\partial B} \end{aligned}$$

$$\begin{aligned}\frac{\partial f}{\partial p} &= f_s \frac{\partial s_T}{\partial p} + f_e \frac{\partial e_T}{\partial p} \\ \frac{\partial f}{\partial \tau_e} &= f_s \frac{\partial s_T}{\partial \tau_e} + f_e \frac{\partial e_T}{\partial \tau_e}\end{aligned}$$

The same can be computed for the production function in the nontraded sector in sectoral form,

$$\begin{aligned}\frac{\partial h}{\partial S} &= h_s \frac{\partial s_N}{\partial S} + h_e \frac{\partial e_N}{\partial S} \\ \frac{\partial h}{\partial B} &= h_s \frac{\partial s_N}{\partial B} + h_e \frac{\partial e_N}{\partial B} \\ \frac{\partial h}{\partial p} &= h_s \frac{\partial s_N}{\partial p} + h_e \frac{\partial e_N}{\partial p} \\ \frac{\partial h}{\partial \tau_e} &= h_s \frac{\partial s_N}{\partial \tau_e} + h_e \frac{\partial e_N}{\partial \tau_e}\end{aligned}$$

The partial derivatives for $h_s(s_N, e_N)$ are given by,

$$\begin{aligned}\frac{\partial h_s}{\partial S} &= h_{ss} \frac{\partial s_N}{\partial S} + h_{se} \frac{\partial e_N}{\partial S} \\ \frac{\partial h_s}{\partial B} &= h_{ss} \frac{\partial s_N}{\partial B} + h_{se} \frac{\partial e_N}{\partial B} \\ \frac{\partial h_s}{\partial p} &= h_{ss} \frac{\partial s_N}{\partial p} + h_{se} \frac{\partial e_N}{\partial p} \\ \frac{\partial h_s}{\partial \tau_e} &= h_{ss} \frac{\partial s_N}{\partial \tau_e} + h_{se} \frac{\partial e_N}{\partial \tau_e}\end{aligned}$$

C.2 Dynamics of the Aggregate Economy

The dynamical system is given by,

$$\begin{aligned}\dot{S} &= (1 - L_T)h(s_N, e_N) - \left(\frac{1 - \theta}{1 + \eta}\right) \frac{C}{p} - \delta_S S \\ \left(1 + \frac{\partial E}{\partial B}\right) \dot{B} &= \left(L_T f(s_T, e_T) + i \left(\frac{B}{pS}\right) B - \frac{(\theta + \theta \tau_c + \eta)}{(1 + \eta)(1 + \tau_c)} C\right) \\ &\quad - \left(\frac{\partial E}{\partial p} \dot{p} + \frac{\partial E}{\partial S} \dot{S} + \frac{\partial E}{\partial \tau_e} \dot{\tau}_e + \delta_E E\right) \\ \dot{p} &= p \left[i \left(\frac{B}{pS}\right) + \delta_S - h_s(s_N, e_N) \right] \\ \dot{C} &= \frac{C}{1 - \gamma(1 + \eta)} \left[(1 - \theta)\gamma (h_s(\cdot) - \delta_S) + [1 - (1 - \theta)\gamma] i(\cdot) - \beta - \frac{\eta\gamma}{1 + \tau_c} \dot{\tau}_c \right] \\ \dot{\tau}_c &= -\nu_c(\tau_c - \tilde{\tau}_c) \\ \dot{\tau}_e &= -\nu_e(\tau_e - \tilde{\tau}_e)\end{aligned}$$

This system can be written as,

$$\underbrace{\begin{bmatrix} 1 & 0 & 0 & 0 & 0 & 0 \\ \frac{\partial E}{\partial S} & 1 + \frac{\partial E}{\partial B} & \frac{\partial E}{\partial p} & 0 & 0 & \frac{\partial E}{\partial \tau_e} \\ 0 & 0 & 1 & 0 & 0 & 0 \\ 0 & 0 & 0 & \frac{1-\gamma(1+\eta)}{C} & \frac{\eta\gamma}{1+\tau_c} & 0 \\ 0 & 0 & 0 & 0 & 1 & 0 \\ 0 & 0 & 0 & 0 & 0 & 1 \end{bmatrix}}_{\mathbf{A}(\mathbf{x})} \cdot \underbrace{\begin{pmatrix} \dot{S} \\ \dot{B} \\ \dot{p} \\ \dot{C} \\ \dot{\tau}_c \\ \dot{\tau}_e \end{pmatrix}}_{\dot{\mathbf{x}}} = \underbrace{\begin{bmatrix} (1-L_T)h(s_N, e_N) - \left(\frac{1-\theta}{1+\eta}\right)\frac{C}{p} - \delta_S S \\ L_T f(s_T, e_T) + i\left(\frac{B}{pS}\right)B - \frac{(\theta+\theta\tau_c+\eta)}{(1+\eta)(1+\tau_c)}C - \delta_E \\ p \left[i\left(\frac{B}{pS}\right) + \delta_S - h_s(s_N, e_N) \right] \\ [(1-\theta)\gamma(h_s(\cdot) - \delta_S) + [1 - (1-\theta)\gamma]i(\cdot) - \\ -\nu_c(\tau_c - \tilde{\tau}_c) \\ -\nu_e(\tau_e - \tilde{\tau}_e) \end{bmatrix}}_{\mathbf{M}(\mathbf{x})}$$

We know that matrix $\mathbf{A}(\mathbf{x})$ is non-singular.¹ Hence, we may write,

$$\dot{\mathbf{x}} = \mathbf{A}^{-1}(\mathbf{x}) \cdot \mathbf{M}(\mathbf{x}) \quad (\text{C.6})$$

Next, we linearize (C.6) around the steady state.² Notice that given that \mathbf{A} is non-singular, then \mathbf{A} is different to zero at all times. Hence, at the steady state the only choice is that $\mathbf{M}(\tilde{\mathbf{x}}) = 0$. Following the usual procedure,

$$\begin{aligned} \dot{\mathbf{x}} &= \dot{\mathbf{x}}|_{SS} + \left(\frac{\partial \mathbf{A}^{-1}}{\partial \mathbf{x}} \mathbf{M}(\mathbf{x}) + \mathbf{A}^{-1}(\mathbf{x}) \frac{\partial \mathbf{M}}{\partial \mathbf{x}} \right) \Big|_{SS} (\mathbf{x} - \tilde{\mathbf{x}}) \\ &= \dot{\mathbf{x}}|_{SS} - \left(\mathbf{A}^{-1} \frac{\partial \mathbf{A}}{\partial \mathbf{x}} \mathbf{A}^{-1} \underbrace{\mathbf{M}}_{=0} \right) \Big|_{SS} \cdot (\mathbf{x} - \tilde{\mathbf{x}}) + \left(\mathbf{A}^{-1} \frac{\partial \mathbf{M}}{\partial \mathbf{x}} \right) \Big|_{SS} \cdot (\mathbf{x} - \tilde{\mathbf{x}}) \end{aligned}$$

Hence,

$$\dot{\mathbf{x}} = \mathbf{A}^{-1}(\tilde{\mathbf{x}}) \frac{\partial \mathbf{M}}{\partial \mathbf{x}} \Big|_{SS} \cdot (\mathbf{x} - \tilde{\mathbf{x}}) \quad (\text{C.7})$$

This yields to a system of the form,

$$\begin{pmatrix} \dot{S} \\ \dot{B} \\ \dot{p} \\ \dot{C} \\ \dot{\tau}_c \\ \dot{\tau}_e \end{pmatrix} = \mathbf{A}^{-1}(\tilde{\mathbf{x}}) \cdot \begin{bmatrix} m_{11} & m_{12} & m_{13} & m_{14} & 0 & m_{16} \\ m_{21} & m_{22} & m_{23} & m_{24} & m_{25} & m_{26} \\ m_{31} & m_{32} & m_{33} & 0 & 0 & m_{36} \\ m_{41} & m_{42} & m_{43} & 0 & 0 & m_{46} \\ 0 & 0 & 0 & 0 & -\nu_c & 0 \\ 0 & 0 & 0 & 0 & 0 & -\nu_e \end{bmatrix}_{\mathbf{x}_{SS} \in \mathbb{R}^6} \cdot \begin{pmatrix} S - \tilde{S} \\ B - \tilde{B} \\ p - \tilde{p} \\ C - \tilde{C} \\ \tau_c - \tilde{\tau}_c \\ \tau_e - \tilde{\tau}_e \end{pmatrix} \quad (\text{C.8})$$

¹The determinant of \mathbf{A} is different to zero at all points in the domain.

²We drop arrows from vector \mathbf{x} .

We have the following partial derivatives,

$$\begin{aligned}
m_{11} &= -h(\tilde{s}_N, \tilde{e}_N) \frac{\partial L_T}{\partial S} \Big|_{SS} + (1 - \tilde{L}_T) \frac{\partial h(s_N, e_N)}{\partial S} \Big|_{SS} - \delta_S \\
m_{12} &= -h(\tilde{s}_N, \tilde{e}_N) \frac{\partial L_T}{\partial B} \Big|_{SS} + (1 - \tilde{L}_T) \frac{\partial h(s_N, e_N)}{\partial B} \Big|_{SS} \\
m_{13} &= -h(\tilde{s}_N, \tilde{e}_N) \frac{\partial L_T}{\partial p} \Big|_{SS} + (1 - \tilde{L}_T) \frac{\partial h(s_N, e_N)}{\partial p} \Big|_{SS} + \left(\frac{1 - \theta}{1 + \eta} \right) \frac{\tilde{C}}{\tilde{p}^2} \\
m_{14} &= - \left(\frac{1 - \theta}{1 + \eta} \right) \frac{1}{\tilde{p}} \\
m_{15} &= 0 \\
m_{16} &= -h(\tilde{s}_N, \tilde{e}_N) \frac{\partial L_T}{\partial \tau_e} \Big|_{SS} + (1 - \tilde{L}_T) \frac{\partial h(s_N, e_N)}{\partial \tau_e} \Big|_{SS}
\end{aligned}$$

All partial derivatives in these equations are determined in the short run in appendix C.1. All partial derivatives below are evaluated at the steady state. We drop tildes just for notational convenience. The elements of \mathbf{M} linearized around the steady state for the second row correspond to,

$$\begin{aligned}
m_{21} &= f \frac{\partial L_T}{\partial S} + f_s L_T \frac{\partial s_T}{\partial S} + f_e L_T \frac{\partial e_T}{\partial S} - i'(\cdot) \frac{B^2}{pS^2} - \delta_E \frac{\partial E}{\partial S} \\
m_{22} &= f \frac{\partial L_T}{\partial B} + f_s L_T \frac{\partial s_T}{\partial B} + f_e L_T \frac{\partial e_T}{\partial B} + i'(\cdot) \frac{B}{pS} + i(\cdot) - \delta_E \frac{\partial E}{\partial B} \\
m_{23} &= f \frac{\partial L_T}{\partial p} + f_s L_T \frac{\partial s_T}{\partial p} + f_e L_T \frac{\partial e_T}{\partial p} - i'(\cdot) \frac{B^2}{p^2 S} - \delta_E \frac{\partial E}{\partial p} \\
m_{24} &= - \frac{(\theta + \theta \tau_c + \eta)}{(1 + \eta)(1 + \tau_c)} \\
m_{25} &= \left(\frac{\eta}{1 + \eta} \right) \frac{C}{(1 + \tau_c)^2} \\
m_{26} &= f \frac{\partial L_T}{\partial \tau_e} + f_s L_T \frac{\partial s_T}{\partial \tau_e} + f_e L_T \frac{\partial e_T}{\partial \tau_e} - \delta_E \frac{\partial E}{\partial \tau_e}
\end{aligned}$$

For the third and fourth row of M , we get,

$$\begin{aligned}
m_{31} &= -p \left[i'(\cdot) \left(\frac{B}{pS^2} \right) + \frac{\partial h_s}{\partial S} \right] \\
m_{32} &= p \left[i'(\cdot) \frac{1}{pS} - \frac{\partial h_s}{\partial B} \right] \\
m_{33} &= -p \left[i'(\cdot) \left(\frac{B}{p^2S} \right) + \frac{\partial h_s}{\partial p} \right] \\
m_{34} &= 0 \\
m_{35} &= 0 \\
m_{36} &= -p \frac{\partial h_s}{\partial \tau_e} \\
\\
m_{41} &= (1-\theta)\gamma \frac{\partial h_s}{\partial S} - (1-(1-\theta)\gamma) i'(\cdot) \left(\frac{B}{pS^2} \right) \\
m_{42} &= (1-\theta)\gamma \frac{\partial h_s}{\partial B} + (1-(1-\theta)\gamma) i'(\cdot) \frac{1}{pS} \\
m_{43} &= (1-\theta)\gamma \frac{\partial h_s}{\partial p} - (1-(1-\theta)\gamma) i'(\cdot) \left(\frac{B}{p^2S} \right) \\
m_{44} &= 0 \\
m_{45} &= 0 \\
m_{46} &= (1-\theta)\gamma \frac{\partial h_s}{\partial \tau_e}
\end{aligned}$$

We define,

$$\mathbf{D} = (\mathbf{A}^{-1}(\tilde{\mathbf{x}}))_{6 \times 6} \cdot (\mathbf{M}(\tilde{\mathbf{x}}))_{6 \times 6}$$

where $\tilde{\mathbf{x}}$ corresponds to the column vector $(\tilde{S}, \tilde{B}, \tilde{p}, \tilde{C}, \tilde{\tau}_c, \tilde{\tau}_e)^T$. Thus, we can rewrite the linearized system as,

$$\begin{pmatrix} \dot{S} \\ \dot{B} \\ \dot{p} \\ \dot{C} \\ \dot{\tau}_c \\ \dot{\tau}_e \end{pmatrix} = \begin{bmatrix} d_{11} & d_{12} & d_{13} & d_{14} & 0 & d_{16} \\ d_{21} & d_{22} & d_{23} & d_{24} & d_{25} & d_{26} \\ d_{31} & d_{32} & d_{33} & 0 & 0 & d_{36} \\ d_{41} & d_{42} & d_{43} & 0 & d_{45} & d_{46} \\ 0 & 0 & 0 & 0 & -\nu_c & 0 \\ 0 & 0 & 0 & 0 & 0 & -\nu_e \end{bmatrix}_{\mathbf{x}_{SS} \in \mathbb{R}^6} \cdot \begin{pmatrix} S - \tilde{S} \\ B - \tilde{B} \\ p - \tilde{p} \\ C - \tilde{C} \\ \tau_c - \tilde{\tau}_c \\ \tau_e - \tilde{\tau}_e \end{pmatrix} \quad (\text{C.9})$$

The solution to this linearized system can be written as,

$$\mathbf{x}(t) - \tilde{\mathbf{x}} = A_1 \mathbf{v}_1 e^{\mu_1 t} + A_2 \mathbf{v}_2 e^{\mu_2 t} + A_3 \mathbf{v}_3 e^{-\nu_c t} + A_4 \mathbf{v}_4 e^{-\nu_e t} \quad (\text{C.10})$$

where $\mu_1, \mu_2 < 0$ are stable roots of the system determined endogenously, while $-\nu_c, -\nu_e < 0$ are stable roots of the system imposed exogenously. Vectors $\mathbf{v}_1, \mathbf{v}_2, \mathbf{v}_3, \mathbf{v}_4$ correspond to the eigenvectors associated with the eigenvalues $\mu_1, \mu_2, -\nu_c, -\nu_e$, respectively. The arbitrary constants, A_1, A_2, A_3, A_4 are obtained from initial conditions on the sluggish variables S, B, τ_c, τ_e . We normalize vectors \mathbf{v}_1 and \mathbf{v}_2 such that their first component is 1. Thus, they can be written as $\mathbf{v}_j = (1, \kappa_{2j}, \kappa_{3j}, \kappa_{4j}, \kappa_{5j}, \kappa_{6j})^T$ for $j = 1, 2$. Further notice that $\kappa_{5j} = \kappa_{6j} = 0$ because of the exogenous nature of τ_c and τ_e . Similarly, we normalize \mathbf{v}_3 and \mathbf{v}_4 such that their component associated with the respective tariff is equal to one. That is, $\mathbf{v}_3 = (\pi_{11}, \pi_{21}, \pi_{31}, \pi_{41}, 1, 0)^T$ and $\mathbf{v}_4 = (\pi_{12}, \pi_{22}, \pi_{32}, \pi_{42}, 0, 1)^T$.

We can determine the constants by evaluating (C.10) at time zero,

$$\begin{aligned} A_1 + A_2 &= (S_0 - \tilde{S}) - A_3\pi_{11} - A_4\pi_{12} \\ A_1\kappa_{21} + A_2\kappa_{22} &= (B_0 - \tilde{B}) - A_3\pi_{21} - A_4\pi_{22} \\ A_3 &= (\tau_{c,0} - \tilde{\tau}_c) \\ A_4 &= (\tau_{e,0} - \tilde{\tau}_e) \end{aligned}$$

Notice that given the exogeneity assumption for the behavior of τ_c , we can compute the normalized eigenvector by,

$$\begin{bmatrix} d_{11} + \nu_c & d_{12} & d_{13} & d_{14} & 0 \\ d_{21} & d_{22} + \nu_c & d_{23} & d_{24} & d_{25} \\ d_{31} & d_{32} & d_{33} + \nu_c & 0 & 0 \\ d_{41} & d_{42} & d_{43} & +\nu_c & d_{45} \\ 0 & 0 & 0 & 0 & 0 \end{bmatrix}_{\mathbf{x}_{SS} \in \mathbb{R}^5} \begin{pmatrix} \pi_{11} \\ \pi_{21} \\ \pi_{31} \\ \pi_{41} \\ 1 \end{pmatrix} = \begin{pmatrix} 0 \\ 0 \\ 0 \\ 0 \\ 0 \end{pmatrix}$$

or equivalently,

$$\begin{bmatrix} d_{11} + \nu_c & d_{12} & d_{13} & d_{14} \\ d_{21} & d_{22} + \nu_c & d_{23} & d_{24} \\ d_{31} & d_{32} & d_{33} + \nu_c & 0 \\ d_{41} & d_{42} & d_{43} & +\nu_c \end{bmatrix}_{\mathbf{x}_{SS} \in \mathbb{R}^4} \begin{pmatrix} \pi_{11} \\ \pi_{21} \\ \pi_{31} \\ \pi_{41} \end{pmatrix} = \begin{pmatrix} 0 \\ -d_{25} \\ 0 \\ -d_{45} \end{pmatrix}$$

The same is performed for τ_e . This yields,

$$\begin{bmatrix} d_{11} + \nu_e & d_{12} & d_{13} & d_{14} \\ d_{21} & d_{22} + \nu_e & d_{23} & d_{24} \\ d_{31} & d_{32} & d_{33} + \nu_e & 0 \\ d_{41} & d_{42} & d_{43} & +\nu_e \end{bmatrix}_{\mathbf{x}_{SS} \in \mathbb{R}^4} \begin{pmatrix} \pi_{12} \\ \pi_{22} \\ \pi_{32} \\ \pi_{42} \end{pmatrix} = \begin{pmatrix} -d_{16} \\ -d_{26} \\ -d_{36} \\ -d_{46} \end{pmatrix}$$

Knowing all these constants, eigenvalues and eigenvectors, we can write the solution to the dynamic system as,

$$S(t) - \tilde{S} = A_1 e^{\mu_1 t} + A_2 e^{\mu_2 t} + \pi_{11}(\tau_{c,0} - \tilde{\tau}_c) e^{-\nu_c t} + \pi_{12}(\tau_{e,0} - \tilde{\tau}_e) e^{-\nu_e t} \quad (\text{C.11a})$$

$$B(t) - \tilde{B} = A_1 \kappa_{21} e^{\mu_1 t} + A_2 \kappa_{22} e^{\mu_2 t} + \pi_{21}(\tau_{c,0} - \tilde{\tau}_c) e^{-\nu_c t} + \pi_{22}(\tau_{e,0} - \tilde{\tau}_e) e^{-\nu_e t} \quad (\text{C.11b})$$

$$p(t) - \tilde{p} = A_1 \kappa_{31} e^{\mu_1 t} + A_2 \kappa_{32} e^{\mu_2 t} + \pi_{31}(\tau_{c,0} - \tilde{\tau}_c) e^{-\nu_c t} + \pi_{32}(\tau_{e,0} - \tilde{\tau}_e) e^{-\nu_e t} \quad (\text{C.11c})$$

$$C(t) - \tilde{C} = A_1 \kappa_{41} e^{\mu_1 t} + A_2 \kappa_{42} e^{\mu_2 t} + \pi_{41}(\tau_{c,0} - \tilde{\tau}_c) e^{-\nu_c t} + \pi_{42}(\tau_{e,0} - \tilde{\tau}_e) e^{-\nu_e t} \quad (\text{C.11d})$$

Notice that, we recover our assumption from solving the system as described above,

$$\tau_c(t) - \tilde{\tau}_c = (\tau_{c,0} - \tilde{\tau}_c) e^{-\nu_c t} \quad (\text{C.12a})$$

$$\tau_e(t) - \tilde{\tau}_e = (\tau_{e,0} - \tilde{\tau}_e) e^{-\nu_e t} \quad (\text{C.12b})$$

C.3 Linearization of the Relative Wealth Equation

Let us recall equation (4.41),

$$\dot{v}_j = \frac{1}{V} \left[(C(t) - w(t) - T(t)) (v_j - 1) + (1 - \varphi_j) C(t) \right]$$

We also know,

$$\begin{aligned} T(t) &= \tau_c C_F + \tau_e I_E \\ C_F &= \left(\frac{\eta}{1 + \eta} \right) \frac{C}{(1 + \tau_c)} \\ I_E &= \dot{E} + \delta_E E \end{aligned}$$

This implies,

$$T(t) = \left(\frac{\eta}{1 + \eta} \right) \left(\frac{\tau_c}{1 + \tau_c} \right) C(t) + \tau_e \dot{E}(t) + \tau_e \delta_E E(t)$$

Substituting all this back into (4.41), we get,

$$\dot{v}_j(t) = \frac{1}{V} \left[\left(\left[\frac{1 + \eta + \tau_c}{(1 + \eta)(1 + \tau_c)} \right] C(t) - w(t) - \tau_e \dot{E}(t) - \tau_e \delta_E E(t) \right) (v_j - 1) + (1 - \varphi_j) C(t) \right] \quad (\text{C.13})$$

Remember that $w(t)$ is a function of sectoral intensities that in turn are functions of p, B, S and τ_e . Namely,

$$w(t) \equiv w(s_T, e_T) \equiv f(s_T, e_T) - s_T f_s(s_T, e_T) - e_T f_e(s_T, e_T) \quad (\text{C.14})$$

Therefore, linearizing around the steady state is of the form,

$$\begin{aligned} \dot{v}_j &= \cancel{\dot{v}_j} \Big|_{SS} + \frac{\partial \dot{v}_j}{\partial v_j} \Big|_{SS} (v_j - \tilde{v}_j) + \frac{\partial \dot{v}_j}{\partial p} \Big|_{SS} (p - \tilde{p}) + \frac{\partial \dot{v}_j}{\partial C} \Big|_{SS} (C - \tilde{C}) + \frac{\partial \dot{v}_j}{\partial B} \Big|_{SS} (B - \tilde{B}) + \frac{\partial \dot{v}_j}{\partial S} \Big|_{SS} (S - \tilde{S}) \\ &\quad + \frac{\partial \dot{v}_j}{\partial \tau_c} \Big|_{SS} (\tau_c - \tilde{\tau}_c) + \frac{\partial \dot{v}_j}{\partial \tau_e} \Big|_{SS} (\tau_e - \tilde{\tau}_e) \end{aligned} \quad (\text{C.15})$$

where each term is given by,

$$\begin{aligned} \frac{\partial \dot{v}_j}{\partial v_j} \Big|_{SS} &= \beta \\ \frac{\partial \dot{v}_j}{\partial p} \Big|_{SS} &= -\frac{(\tilde{v}_j - 1)}{\tilde{V}} \left[\frac{\partial w}{\partial p} + \tilde{\tau}_e \frac{\partial \dot{E}}{\partial p} + \tilde{\tau}_e \delta_E \frac{\partial E}{\partial p} \right]_{SS} \\ \frac{\partial \dot{v}_j}{\partial C} \Big|_{SS} &= \frac{(\tilde{v}_j - 1)}{\tilde{V}} \left[\frac{1 + \eta + \tilde{\tau}_c}{(1 + \eta)(1 + \tilde{\tau}_c)} - \frac{\beta \tilde{V}}{\tilde{C}} \right]_{SS} \\ \frac{\partial \dot{v}_j}{\partial B} \Big|_{SS} &= -\frac{(\tilde{v}_j - 1)}{\tilde{V}} \left[\frac{\partial w}{\partial B} + \tilde{\tau}_e \frac{\partial \dot{E}}{\partial B} + \tilde{\tau}_e \delta_E \frac{\partial E}{\partial B} \right]_{SS} \\ \frac{\partial \dot{v}_j}{\partial S} \Big|_{SS} &= -\frac{(\tilde{v}_j - 1)}{\tilde{V}} \left[\frac{\partial w}{\partial S} + \tilde{\tau}_e \frac{\partial \dot{E}}{\partial S} + \tilde{\tau}_e \delta_E \frac{\partial E}{\partial S} \right]_{SS} \\ \frac{\partial \dot{v}_j}{\partial \tau_c} \Big|_{SS} &= -\frac{(\tilde{v}_j - 1)}{\tilde{V}} \left(\frac{\eta}{1 + \eta} \right) \frac{\tilde{C}}{(1 + \tilde{\tau}_c)^2} \\ \frac{\partial \dot{v}_j}{\partial \tau_e} \Big|_{SS} &= -\frac{(\tilde{v}_j - 1)}{\tilde{V}} \left[\frac{\partial w}{\partial \tau_e} + \tilde{\tau}_e \frac{\partial \dot{E}}{\partial \tau_e} + \tilde{\tau}_e \delta_E \frac{\partial E}{\partial \tau_e} + \delta_E \tilde{E} \right]_{SS} \end{aligned}$$

Thus, we can write the linearized law of motion for relative tax-adjusted wealth

as,

$$\begin{aligned} \dot{v}_j = & \beta(v_j - \tilde{v}_j) - \frac{(\tilde{v}_j - 1)}{\tilde{V}} \left[\sum_{x_k \in \{p, B, S\}} \left(\tilde{w}_{x_k} + \tilde{\tau}_e \frac{\partial \dot{E}}{\partial x_k} \Big|_{SS} + \tilde{\tau}_e \delta_E \tilde{E}_{x_k} \right) (x_k - \tilde{x}_k) \right. \\ & + \left. \left(\frac{\eta}{1 + \eta} \right) \frac{\tilde{C}}{(1 + \tilde{\tau}_c)^2} (\tau_c - \tilde{\tau}_c) + \left(\tilde{w}_{\tau_e} + \tilde{\tau}_e \frac{\partial \dot{E}}{\partial \tau_e} \Big|_{SS} + \tilde{\tau}_e \delta_E \tilde{E}_{\tau_e} + \delta_E \tilde{E} \right) (\tau_e - \tilde{\tau}_e) \right] \\ & + \frac{(\tilde{v}_j - 1)}{\tilde{V}} \left[\tilde{\tau}_e \delta_E \tilde{E} + \tilde{w} \right] \left(\frac{C - \tilde{C}}{\tilde{C}} \right) \end{aligned}$$

rearranging terms we get,

$$\dot{v}_j = \beta(v_j - \tilde{v}_j) - \frac{\tilde{v}_j - 1}{\tilde{V}} \left[\sum_{x \in \{p, B, S\}} \Gamma_x (x - \tilde{x}) + \Gamma_{\tau_c} (\tau_c - \tilde{\tau}_c) + \Gamma_{\tau_e} (\tau_e - \tilde{\tau}_e) + \Gamma_C (C - \tilde{C}) \right] \quad (\text{C.16})$$

where we define,

$$\begin{aligned} \Gamma_x &= \frac{\partial w}{\partial x} \Big|_{SS} + \tilde{\tau}_e \frac{\partial \dot{E}}{\partial x} \Big|_{SS} + \tilde{\tau}_e \delta_E \frac{\partial E}{\partial x} \Big|_{SS} \quad \forall x \in p, B, S \\ \Gamma_{\tau_c} &= \left(\frac{\eta}{1 + \eta} \right) \frac{\tilde{C}}{(1 + \tilde{\tau}_c)^2} \\ \Gamma_{\tau_e} &= \frac{\partial w}{\partial \tau_e} \Big|_{SS} + \tilde{\tau}_e \frac{\partial \dot{E}}{\partial \tau_e} \Big|_{SS} + \tilde{\tau}_e \delta_E \frac{\partial E}{\partial \tau_e} \Big|_{SS} + \delta_E \tilde{E} \\ \Gamma_C &= -\frac{\tilde{\tau}_e \delta_E \tilde{E} + \tilde{w}}{\tilde{C}} \end{aligned}$$

Following [Turnovsky and García-Peñalosa \(2008\)](#), the solution to this differential equation is given by,

$$v_j(t) - 1 = (\tilde{v}_j - 1) \left[1 + \sum_{x \in \Omega} \left(\frac{\Gamma_x}{\tilde{V}} \int_t^\infty (x(u) - \tilde{x}) e^{-\beta(u-t)} du \right) \right] \quad \Omega = \{p, B, S, C, \tau_c, \tau_e\} \quad (\text{C.17})$$

We define,

$$\chi(t) = \left[1 + \sum_{x \in \Omega} \left(\frac{\Gamma_x}{\tilde{V}} \int_t^\infty (x(u) - \tilde{x}) e^{-\beta(u-t)} du \right) \right] \quad \Omega = \{p, B, S, C, \tau_c, \tau_e\}$$

Hence, we can write,

$$v_j(t) - 1 = \chi(t) (\tilde{v}_j - 1) \quad (\text{C.18})$$

Applying the standard deviation operator yields,

$$\sigma_v = \chi(t) \tilde{\sigma}_v \quad (\text{C.19})$$

$\chi(t)$ can be written in terms of the known solutions for the aggregate economy as,

$$\chi(t) = 1 + \frac{\Omega_1}{\mu_1 - \beta} e^{\mu_1 t} + \frac{\Omega_2}{\mu_2 - \beta} e^{\mu_2 t} - \frac{\Omega_3}{\nu_c + \beta} e^{-\nu_c t} - \frac{\Omega_4}{\nu_e + \beta} e^{-\nu_e t} \quad (\text{C.20})$$

where,

$$\begin{aligned} \Omega_1 &= -\frac{A_1}{\tilde{V}} (\Gamma_S + \Gamma_B \kappa_{21} + \Gamma_p \kappa_{31} + \Gamma_C \kappa_{41}) \\ \Omega_2 &= -\frac{A_2}{\tilde{V}} (\Gamma_S + \Gamma_B \kappa_{22} + \Gamma_p \kappa_{32} + \Gamma_C \kappa_{42}) \\ \Omega_3 &= -\frac{1}{\tilde{V}} (\Gamma_{\tau_c} + \Gamma_S \pi_{11} + \Gamma_B \pi_{21} + \Gamma_p \pi_{31} + \Gamma_C \pi_{41}) \\ \Omega_4 &= -\frac{1}{\tilde{V}} (\Gamma_{\tau_e} + \Gamma_S \pi_{12} + \Gamma_B \pi_{22} + \Gamma_p \pi_{32} + \Gamma_C \pi_{42}) \end{aligned}$$

All partial derivatives involved above are known and *evaluated* at the steady state,

$$\begin{aligned} \frac{\partial i}{\partial p} &= -\left(\frac{B}{p^2 S}\right) i'(\cdot); \quad \frac{\partial i}{\partial S} = -\left(\frac{B}{p S^2}\right) i'(\cdot); \quad \frac{\partial i}{\partial B} = \frac{1}{p S} i'(\cdot) \\ \frac{\partial \dot{E}}{\partial p} \Big|_{SS} &= \left(\frac{\partial E}{\partial p} \frac{\partial \dot{p}}{\partial p} + \frac{\partial E}{\partial B} \frac{\partial \dot{B}}{\partial p} + \frac{\partial E}{\partial S} \frac{\partial \dot{S}}{\partial p} \right) \Big|_{SS} \\ \frac{\partial \dot{E}}{\partial B} \Big|_{SS} &= \left(\frac{\partial E}{\partial p} \frac{\partial \dot{p}}{\partial B} + \frac{\partial E}{\partial B} \frac{\partial \dot{B}}{\partial B} + \frac{\partial E}{\partial S} \frac{\partial \dot{S}}{\partial B} \right) \Big|_{SS} \\ \frac{\partial \dot{E}}{\partial S} \Big|_{SS} &= \left(\frac{\partial E}{\partial p} \frac{\partial \dot{p}}{\partial S} + \frac{\partial E}{\partial B} \frac{\partial \dot{B}}{\partial S} + \frac{\partial E}{\partial S} \frac{\partial \dot{S}}{\partial S} \right) \Big|_{SS} \end{aligned}$$

For notational convenience we drop the sign that indicates the derivatives being evaluated at the steady state,

$$\begin{aligned} \frac{\partial \dot{E}}{\partial \tau_e} &= \frac{\partial E}{\partial p} \frac{\partial \dot{p}}{\partial \tau_e} + \frac{\partial E}{\partial B} \frac{\partial \dot{B}}{\partial \tau_e} + \frac{\partial E}{\partial S} \frac{\partial \dot{S}}{\partial \tau_e} - \nu_e \frac{\partial E}{\partial \tau_e} \\ \frac{\partial \dot{B}}{\partial p} &= \left(1 + \frac{\partial E}{\partial B}\right)^{-1} \left[f \frac{\partial L_T}{\partial p} + L_T \frac{\partial f}{\partial p} + \frac{\partial i}{\partial p} - \frac{\partial E}{\partial p} \frac{\partial \dot{p}}{\partial p} - \frac{\partial E}{\partial S} \frac{\partial \dot{S}}{\partial p} - \delta_E \frac{\partial E}{\partial p} \right] \\ \frac{\partial \dot{B}}{\partial B} &= \left(1 + \frac{\partial E}{\partial B}\right)^{-1} \left[f \frac{\partial L_T}{\partial B} + L_T \frac{\partial f}{\partial B} + \frac{\partial i}{\partial B} - \frac{\partial E}{\partial p} \frac{\partial \dot{p}}{\partial B} - \frac{\partial E}{\partial S} \frac{\partial \dot{S}}{\partial B} - \delta_E \frac{\partial E}{\partial B} \right] \\ \frac{\partial \dot{B}}{\partial S} &= \left(1 + \frac{\partial E}{\partial B}\right)^{-1} \left[f \frac{\partial L_T}{\partial S} + L_T \frac{\partial f}{\partial S} + \frac{\partial i}{\partial S} - \frac{\partial E}{\partial p} \frac{\partial \dot{p}}{\partial S} - \frac{\partial E}{\partial S} \frac{\partial \dot{S}}{\partial S} - \delta_E \frac{\partial E}{\partial S} \right] \\ \frac{\partial \dot{B}}{\partial \tau_e} &= \left(1 + \frac{\partial E}{\partial B}\right)^{-1} \left[f \frac{\partial L_T}{\partial \tau_e} + L_T \frac{\partial f}{\partial \tau_e} - \frac{\partial E}{\partial p} \frac{\partial \dot{p}}{\partial \tau_e} - \frac{\partial E}{\partial S} \frac{\partial \dot{S}}{\partial \tau_e} + (\nu_e - \delta_E) \frac{\partial E}{\partial \tau_e} \right] \end{aligned}$$

The partial derivatives for the wage rate at the steady state are given by,

$$\begin{aligned}\frac{\partial w}{\partial p}\Big|_{SS} &= - \left[(s_T f_{ss} + e_T f_{es}) \frac{\partial s_T}{\partial p} + (s_T f_{es} + e_T f_{ee}) \frac{\partial e_T}{\partial p} \right] \Big|_{SS} \\ \frac{\partial w}{\partial B}\Big|_{SS} &= - \left[(s_T f_{ss} + e_T f_{es}) \frac{\partial s_T}{\partial B} + (s_T f_{es} + e_T f_{ee}) \frac{\partial e_T}{\partial B} \right] \Big|_{SS}\end{aligned}$$

$$\begin{aligned}\frac{\partial w}{\partial S}\Big|_{SS} &= - \left[(s_T f_{ss} + e_T f_{es}) \frac{\partial s_T}{\partial S} + (s_T f_{es} + e_T f_{ee}) \frac{\partial e_T}{\partial S} \right] \Big|_{SS} \\ \frac{\partial w}{\partial \tau_e}\Big|_{SS} &= - \left[(s_T f_{ss} + e_T f_{es}) \frac{\partial s_T}{\partial \tau_e} + (s_T f_{es} + e_T f_{ee}) \frac{\partial e_T}{\partial \tau_e} \right] \Big|_{SS}\end{aligned}$$

These expressions can be further reduced to,

$$\frac{\partial w}{\partial p}\Big|_{SS} = -(1 + \tilde{\tau}_e) \frac{B}{p^2 S} i'(\cdot) \left[\tilde{s}_T \left(\frac{\tilde{e}_T - \tilde{e}_N}{\tilde{s}_T - \tilde{s}_N} \right) - \tilde{e}_T \right] + h(\tilde{s}_N, \tilde{e}_N) \frac{\tilde{s}_T}{(\tilde{s}_T - \tilde{s}_N)}$$

Appendix D

**PROOFS OF LEMMAS AND PROPOSITIONS,
CHAPTER 5**

In the following, IVT stands for the “Intermediate Value Theorem”.

Proof of Proposition 5.2. Without loss of generality, assume that $\varepsilon > 0$ is sufficiently small so that $2\varepsilon < y^* < 1 - 2\varepsilon$. Define

$$\delta = \inf\{|x_0(z) - z| : z \in [\varepsilon, y^* - \varepsilon] \cup [y^* + \varepsilon, 1 - \varepsilon]\}$$

$\delta > 0$, since we know from Proposition 5.1 that y^* is the unique fixed point of $x_0(\cdot)$. Next, observe that $x(z, \alpha)$ converges pointwise to $x_0(z)$ for all z in the *compact* interval $[\varepsilon, 1 - \varepsilon]$. From Lemma 5.2, we know that $x(z, \alpha)$ is jointly continuous in both its arguments for $(z, \alpha) \in (0, 1) \times [0, \infty)$. Hence, we can find $\alpha_\varepsilon > 0$ such that

$$|x(z, \alpha) - x_0(z)| < \delta/2 \quad \forall z \in [\varepsilon, 1 - \varepsilon] \text{ and } \forall \alpha \in (0, \alpha_\varepsilon) \quad (\text{D.1})$$

From Proposition 5.1, $x_0(z) - z$ for $z \in [\varepsilon, y^* - \varepsilon]$ which gives

$$x(z, \alpha) - z > x_0(z) - z - \delta/2 \geq \delta/2 \quad \forall z \in [\varepsilon, y^* - \varepsilon]$$

and that $x_0(z) < z$ for $z \in [y^* + \varepsilon, 1 - \varepsilon]$, which gives

$$x(z, \alpha) - z < x_0(z) - z + \delta/2 \leq -\delta/2 \quad \forall z \in [y^* + \varepsilon, 1 - \varepsilon]$$

Therefore, fixed points of $x(\cdot, \alpha)$, if exist, can occur only in the regions $[0, \varepsilon)$, $(y^* - \varepsilon, y^* + \varepsilon)$ or $(1 - \varepsilon, 1]$. This proves Part 2.

From Lemma 5.2, we know that $\lim_{z \rightarrow 0} x(z, \alpha) = -\infty$ and $\lim_{z \rightarrow 1} x(z, \alpha) = \infty$. This, together with the foregoing conclusions concerning $x(z, \alpha)$ allow us to conclude the following regarding the graph of $x(z, \alpha)$: begins from below the 45 degree line when z is close to zero, is above it in the region $[\varepsilon, y^* - \varepsilon]$, is below it in the region $[y^* + \varepsilon, 1 - \varepsilon]$ and again above it for z close enough to 1. Appealing

to the continuity of $x(\cdot, \alpha)$ and applying the IVT, it follows that $x(\cdot, \alpha)$ intersects the 45 degree line at least once in each of the regions $(0, \varepsilon)$, $(y^* - \varepsilon, y^* + \varepsilon)$ and $(\varepsilon, 1 - \varepsilon)$, and only on those regions. Each of these points of intersection in the respective regions constitute the acceptance thresholds for a left extreme equilibrium, a regular equilibrium or a right extreme equilibrium. This completes the proof of Part 1.

Proof of Proposition 5.3. We will prove Part 1. We shall in fact establish the following stronger claim: Let $\varepsilon > 0$ let $0 < \alpha_2 < \alpha_1 < \varepsilon$. For any conformal equilibrium acceptance threshold $y_1 \in (0, \varepsilon)$ that occurs when $\alpha = \alpha_1$, there exists an equilibrium acceptance threshold $y_2 < y_1$ when $\alpha = \alpha_2$.

We first note that at equilibrium $y_1 \in (0, \varepsilon)$, it must be the case that $\varphi(y_1) + \psi(y_1) < 0$. Indeed, from (5.8) we note that $\text{sgn}(\varphi(y_1) + \psi(y_1)) = \text{sgn}(x(y_1, \alpha) - x_0(y_1))$. Using the fact that y_1 is an equilibrium and Proposition 5.1 gives us $x(y_1, \alpha_1) - x_0(y_1) = y_1 - x_0(y_1) < 0$. Now,

$$\begin{aligned} x(y_1, \alpha_2) &= x_0(y_1) + \alpha_2(\varphi(y_1) + \psi(y_1)) \\ &> x_0(y_1) + \alpha_1(\varphi(y_1) + \psi(y_1)) = y_1 \end{aligned}$$

Since $x(y_1, \alpha_2) > y_1$ and $\lim_{z \rightarrow 0} x(y, \alpha_2) = -\infty$, it follows from the IVT that there exists some $y_2 \in (0, y_1)$ such that $x(y_2, \alpha_2) = y_2$.

An analogous argument applies for Part 2.

Lemma D.1 *Let $y \in (0, 1)$ be an equilibrium for some $\alpha > 0$. Relative to y^* , committee is more picky at y if and only if $\varphi(y) + \psi(y) > 0$.*

Proof. Since y is an equilibrium at α , we have $y - x_0(y) = x(y, \alpha) - x_0(y) = \alpha(\varphi(y) + \psi(y))$. Therefore, $\varphi(y) + \psi(y) > 0$ if and only if $y > x_0(y)$, which occurs, using Proposition 5.1, if and only if $y > y^*$.

Proof of Proposition 5.4. We note that

$$V_0(z) = \frac{\left(Q(z, M, N - 1) \int_0^z x dF(x) + Q(z, M - 1, N - 1) \int_z^1 x dF(x) \right)}{(1 - \delta P(z, M, N))} \quad (\text{D.2})$$

Using the β -distribution representation of the cumulative binomial probability, we have

$$P(z, k, n) = \frac{1}{(n+1-k)} \binom{n}{k} \int_0^{F(x)} t^{n-k-1} (1-t)^k dt$$

which gives

$$P_z(z, k, n) = \frac{f(x)}{(n+1-k)} \binom{n}{k} F(z)^{n-k-1} (1-F(z))^k$$

Thus, $P(0, k, n) = 0$ and whenever $n > k - 1$, $P_z(0, k, n) = 0$. Then we have the following $V_0(0) = V'_0(0) = \mu > 0$. Therefore, in a neighborhood of 0, $V_0(z)$ is increasing in z . Therefore, if ε is chosen small enough so that all the left-extreme equilibria are within this neighborhood, the equilibrium with the largest threshold, say y_l , has the highest welfare among all extreme equilibria. In fact, $V_0(y_l) \approx \mu$. Welfare in any regular equilibrium on the other hand is approximately $V_0(y^*)$. Recall (from Proposition 5.1) that $\delta V_0(y^*) = y^*$. Whether a regular equilibrium is Pareto superior or y_l is the Pareto superior equilibrium therefore depends on whether $\mu < \delta y^*$ or $\mu > \delta y^*$, for ε sufficiently small.

The only non-trivial assertion of the proposition that remains unproved is the assertion that (5.9) implies the equilibrium threshold in any regular equilibrium lies to the right of y^* . To prove this, let us suppose for the moment that $\varphi(z) > 0$ whenever $z > z_{\text{med}}$. Recalling the discussion leading to Lemma 5.2, we have $\varphi(z) + \psi(z) > 0$ for all $z > z_{\text{med}}$. Moreover, if, as hypothesized, $y^* > z_{\text{med}}$, then for an $\varepsilon > 0$ small enough, the interval $(y^* - \varepsilon, y^* + \varepsilon)$ lies to the right of z_{med} with every regular equilibrium lying within it (of course, for permissible values of α). An appeal to Lemma D.1 gives us the proposition.

The proof is complete upon showing that φ is in fact an increasing function and that $\varphi(z_{\text{med}}) \geq 0$. We shall first verify that φ is increasing.

$$\begin{aligned} \varphi(z) &= \frac{P(z, M, N-1) - Q(z, M, N-1)}{p(z, M-1, N-1)} \\ &= \frac{1}{\binom{N-1}{M-1}} \sum_{j=0}^{M-1} \binom{N-1}{j} \frac{(1-F(z))^j F(z)^{N-1-j}}{(1-F(z))^{M-1} F(z)^{N-M}} \\ &\quad - \frac{1}{\binom{N-1}{M-1}} \sum_{j=M-1}^{N-1} \binom{N-1}{j} \frac{(1-F(z))^j F(z)^{N-1-j}}{(1-F(z))^{M-1} F(z)^{N-M}} \end{aligned}$$

Straightforward simplification gives

$$\binom{N-1}{M-1} \varphi(z) = \sum_{j=0}^{M-2} \binom{N-1}{j} \theta(z)^{M-1-j} - \sum_{j=M}^{N-1} \binom{N-1}{j} \frac{1}{\theta(z)^{j+1-M}} \quad (\text{D.3})$$

where $\theta(z) = F(z)/(1-F(z))$. Since $\theta(\cdot)$ is increasing, it is clear from above that $\varphi(z)$ is also increasing in z .

Finally, we note that $M \geq (N+1)/2$ is equivalent to $M-2 \geq N-1-M$. Therefore, with $\theta(z_{\text{med}}) = 1$, the first summation in the above equation is no less than the second summation. Hence $\theta(z_{\text{med}}) \geq 0$.

Appendix E

DATA AND ADDITIONAL TABLES, CHAPTER 6

E.1 Variables*E.1.1 Carbon Emissions*

Data on carbon emissions are obtained from the World Development Indicators (WDI) database at the World Bank. This measure is in units of metric tons per-capita to normalize the contribution of a country by its population.

E.1.2 Inequality

Our income Gini data come mainly from two databases. We use the *All The Ginis* (ATG) compiled by [Milanovic \(2014\)](#) that consists only of the Gini coefficients that have been calculated from actual households surveys. It uses no Ginis estimates produced by regressions or short-cut methods. [Milanovic \(2014\)](#) compiles Gini coefficients from nine different sources. These are: the Luxembourg Income Study (LIS), the Socio-Economic Database for Latin America and the Caribbean (SEDLAC), the Survey of Income and Living Condition (SILC), the World Bank's Eastern Europe and Central Asia (ECA), the World Income Distribution (WYD), the PovcalNet from the World Bank, the World Institute for Development Research (WIDER), the Economic Commission for Latin America and the Caribbean (CEPAL), and Individual data sets (INDIE). Notice that he excludes the data from [Deininger and Squire \(1997\)](#) because they have been either superseded or included in WIDER. As a further completion and check of this dataset, we use data coming from the United States Census Bureau and from the National Socio-Economic Characterization Survey (CASEN) provided by the Chilean Ministry of Finance.

We also use the Standardized World Income Inequality Database (SWIID)

developed by [Solt \(2009\)](#). The SWIID uses a custom missing-data multiple-imputation algorithm to standardize observations collected from the United Nations University's World Income Inequality Database (WIID), the OECD Income Distribution Database, the Socio-Economic Database for Latin America and the Caribbean (SEDLAC), the World Bank, Eurostat, the World Bank's PovcalNet, the World Top Incomes Database, the University of Texas Inequality Project, national statistical offices around the world, and other sources. LIS data serve as the standard.

In order to analyze if the profile of the distribution of income or consumption has any effect on carbon emissions, we also make use of income and consumption shares by quintiles data provided by the United Nations University's World Income Inequality Database (WIID) version 3.0b.

E.1.3 Control Variables

Educational Attainment The data on educational attainment are obtained from [Barro and Lee \(2001\)](#) and the updated version [Barro and Lee \(2013\)](#). We pay particular attention to the impact on inequality of primary education and tertiary education more than the effect of the aggregated variable years of schooling.

Political System We obtain data on political rights and civil liberties from the [Freedom House \(2015\)](#). The Freedom House scale ranges from 1.0 (free) to 7.0 (not free).

Macroeconomic Variables Data on exports, imports, GDP per-capita and GDP growth are obtained from the WDI database.

E.1.4 Country Groups

Country name of the given territory updated to 2014. We use the division of territories and income provided by the World Bank. The world is divided in eight regions: Latin America and the Caribbean, Sub-Saharan Africa, Central and

Eastern Europe, Commonwealth of Independent States, Developing Asia, Middle East and North Africa, North America, and Western Europe. Income groups are divided in four groups: low income, \$610 or less (L); low-middle income, \$611-\$2,465 (LM); upper-middle income, \$2,466-\$7,620 (UM); and high income, \$7,621 or more (H). We use the income classification assigned by the World Bank in year 1990, the beginning of our period of analysis.

The following list provides the name of the countries and its number of observations in parentheses. Armenia (3), Australia (11), Austria (11), Azerbaijan (4), Belarus (4), Belgium (12), Brazil (1), Bulgaria (18), Canada (31), Chile (6), China (19), Colombia (3), Costa Rica (1), Croatia (2), Cyprus (4), Czech Republic (13), Denmark (20), Egypt (1), Estonia (18), Finland (31), France (13), Gabon (2), Germany (17), Greece (8), Guatemala (1), Hungary (22), Iceland (4), Ireland (11), Israel (10), Italy (33), Japan (6), Jordan (2), Kazakhstan (2), South Korea (4), Kyrgyz Republic (2), Latvia (13), Lithuania (9), Luxembourg (12), Macedonia (2), Malaysia (2), Mexico (10), Moldova (1), Namibia (1), Nepal (2), Netherlands (23), New Zealand (5), Norway (22), Peru (1), Poland (25), Portugal (11), Romania (10), Russian Federation (19), Singapore (2), Slovak Republic (16), Slovenia (15), South Africa (2), Spain (12), Sweden (26), Switzerland (6), Turkey (2), Turkmenistan (2), Ukraine (1), United Kingdom (50), United States (7), Uruguay (1), Uzbekistan (3), Venezuela (1), Zambia (1).

The SWIID dataset is larger than the ATG dataset, but we do not report the number of observations by country. Let us remember that the SWIID dataset consists of imputations rather than actual observations. Hence, we rely more on the ATG data that comes from country-level surveys.

You may access both datasets at <http://www.jorgerojas.cl/p/data.html>

E.2 Additional Tables

Table E.1: Functional Form

	CO ₂	CO ₂	CO ₂	Log(CO ₂)	Log(CO ₂)	Log(CO ₂)
	(1)	(2)	(3)	(4)	(5)	(6)
Gini	-0.132*** (-2.76)	-0.0764*** (-2.66)	-0.0646** (-2.28)			
Log(Gini)				-0.972*** (-3.45)	-0.340*** (-2.73)	-0.308** (-2.44)
Constant	13.12*** (8.23)	11.29*** (11.97)	10.65*** (9.95)	5.410*** (5.69)	3.214*** (7.44)	3.057*** (6.82)
Country FE	No	Yes	Yes	No	Yes	Yes
Time FE	No	No	Yes	No	No	Yes
Observations	665	665	665	665	665	665
Number of Countries	68	68	68	68	68	68
Adjusted R^2	0.055	0.056	0.112	0.105	0.067	0.102

Notes: * $p < 0.10$, ** $p < 0.05$, *** $p < 0.01$. Standard errors are clustered at the country level. t statistics in parentheses.

Table E.2: Deciles Panel Regressions.

	lnCO2	lnCO2	lnCO2	lnCO2	lnCO2	lnCO2	lnCO2	lnCO2	lnCO2	lnCO2
lnD1	0.0948*** (2.71)									
lnD2		0.215*** (3.84)								
lnD3			0.232*** (2.85)							
lnD4				0.269* (1.97)						
lnD5					0.201 (0.94)					
lnD6						0.183 (0.62)				
lnD7							-0.0655 (-0.19)			
lnD8								-0.457 (-1.15)		
lnD9									-0.427 (-1.65)	
lnD10										-0.196* (-1.81)
Log(GDP pc)	0.253** (2.47)	0.283*** (2.76)	0.285*** (2.75)	0.284*** (2.75)	0.267** (2.60)	0.258** (2.50)	0.252** (2.32)	0.265** (2.39)	0.270** (2.50)	0.264** (2.59)
Political Rights	-0.0208 (-0.80)	-0.0209 (-0.81)	-0.0195 (-0.74)	-0.0188 (-0.71)	-0.0182 (-0.68)	-0.0181 (-0.67)	-0.0178 (-0.65)	-0.0182 (-0.68)	-0.0192 (-0.72)	-0.0182 (-0.69)
Observations	691	690	690	690	690	690	690	690	690	690
# Countries	67	67	67	67	67	67	67	67	67	67
Adjusted R^2	0.142	0.138	0.126	0.121	0.113	0.111	0.108	0.117	0.118	0.119

t statistics in parentheses

* $p < 0.10$, ** $p < 0.05$, *** $p < 0.01$

Table E.3a: Cross-correlation

Variables	CO ₂	Gini	GDP pc	GDP gr.	Pol. Rights	Years of Sch.	Civil Lib.	Imports	Exports	Dom. Credit
CO ₂	1.000									
Gini	-0.237	1.000								
GDP per-capita	0.486	-0.266	1.000							
GDP growth	-0.058	0.134	-0.038	1.000						
Political Rights	-0.329	0.214	-0.522	0.111	1.000					
Years of Schooling	0.356	-0.283	0.299	-0.092	-0.413	1.000				
Civil Liberties	-0.372	0.228	-0.597	0.098	0.931	-0.438	1.000			
Imports	0.152	-0.162	0.170	0.037	-0.094	0.390	-0.112	1.000		
Exports	0.260	-0.183	0.309	0.011	-0.091	0.386	-0.124	0.953	1.000	
Domestic Credit	0.180	-0.074	0.612	-0.079	-0.246	0.244	-0.311	0.087	0.146	1.000

Table E.3b: Cross-correlation

Variables	Fin. Assets	Fin. Liabilities	% with No Sch.	% with Pri. Sch.	% with Sec. Sch.	% with Ter. Sch.
Financial Assets	1.000					
Financial Liabilities	0.999	1.000				
% with No Schooling	-0.001	-0.004	1.000			
% with Primary Schooling	-0.024	-0.024	0.115	1.000		
% with Secondary Schooling	-0.022	-0.020	-0.347	-0.746	1.000	
% with Tertiary Schooling	0.136	0.142	-0.339	-0.583	0.316	1.000

Table E.4: Variance Inflation Factors and Tolerance

	Full model	
	VIF	Tolerance
Gini	1.47	0.681293
GDP per-capita	4.60	0.217557
Political Rights	7.42	0.134796
Years of Schooling	11.55	0.086560
Civil Liberties	8.47	0.118069
Imports	21.27	0.047011
Exports	24.14	0.041419
Domestic Credit	1.81	0.551379
Financial Assets	659.84	0.001516
Financial Liabilities	650.61	0.001537
% with No Schooling	3.87	0.258579
% with Primary Schooling	5.16	0.193959
% with Secondary Schooling	3.78	0.264341
% with Tertiary Schooling	2.99	0.334219
Mean VIF	100.50	
	Benchmark model	
Gini	1.19	0.837343
GDP per-capita	1.38	0.727207
Political Rights	1.50	0.668387
Years of Schooling	1.25	0.798227
Mean VIF	1.33	

VITA

Jorge Rojas is a Civil Engineer graduated from the University of Chile with a Master of Economics at The University of Sydney and a Ph.D. candidate at the University of Washington. His specialization is in macroeconomic theory with a particular focus on growth, international trade and inequality.

He welcomes your comments to economista@jorgerojas.cl. All other relevant information can be found at www.jorgerojas.cl