

Memento Mori | A Non-sectarian Memorial Site in Seattle

Queena Yi

A thesis submitted in partial fulfillment
of the requirements for the degree of

Master of Architecture

University of Washington

2013

Committee:

David Miller, Chair | Ken Tadashi Oshima

Program Authorized to Offer Degree: Architecture

© Copyright 2013

Queena Yi

M E M E N T O M O R I

A Non-sectarian Memorial Site in Seattle

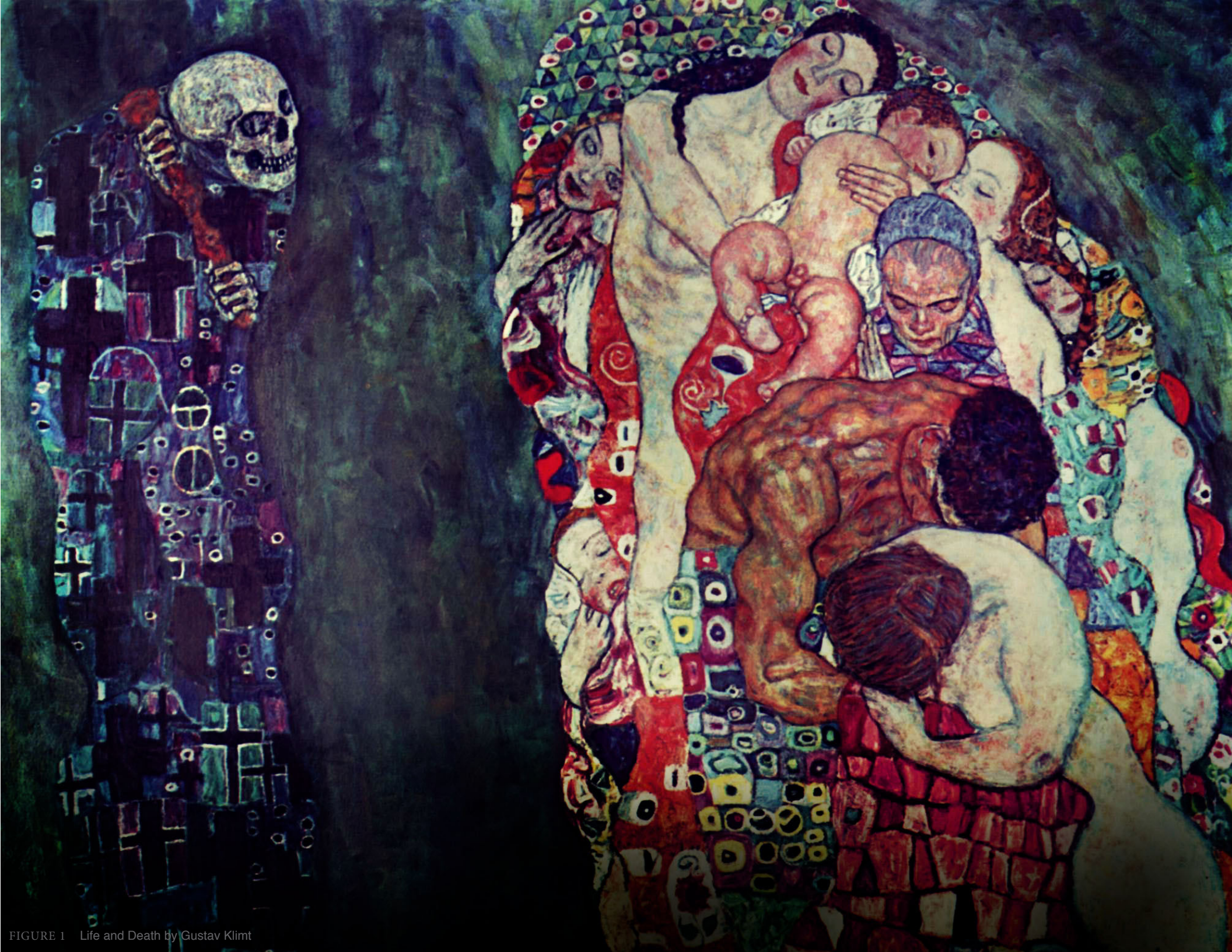

FIGURE 1 Life and Death by Gustav Klimt

TABLE OF CONTENTS

TABLE OF CONTENTS	iii
ACKNOWLEDGMENTS	vi
LIST OF FIGURES	vii
INTRODUCTION	1
THESIS STATEMENT	4
Memento Mori	8
Death in America	10
Existentialism and Death	12
A HISTORY OF THE CITY AND CEMETERY	13
Western Europe	14
North America: The new Land	16
A Death in the community	19
The Rise of the American Funeral Home	21
The War Memorial	22
DEATH IN THE LENS OF OTHER CULTURES	24
Scandinavia	24
Japan	26

Mexico	28
ADDRESSING THE CONTEMPORARY	30
Trends in Cremation	31
The Stagnant Funeral Home	34
Trends in Secularization	35
ARCHITECTURE AND RITUAL	36
Woodland Cemetery, Stockholm Sweden (Asplund and Lewerentz)	36
Iguialada Cemetery, Iguialada, Spain - (Enric Miralles, Carmen Pinos)	38
Kaze-no-Oka, Nakatsu Oita, Japan (Maki and Associates)	41
Assistens Kirkegård, Copenhagen, Denmark	42
SITE SEATTLE, WA	43
History of Seattle Cemeteries	43
Site Selection	46
Potential Sites	47
Site - Belltown and Olympic Sculpture Park	48
Site History	49
DESIGN	52
THE PROGRAM	56

The Digital Media Library	56
Design Methodology	59
Materials	59
The Ceremonial Spaces	61
The Columbarium, Tunnel and Pier	67
Resomation or Bio-Cremation	70
DRAWINGS	71
SECTIONS	73
SITE CIRCULATION	74
MOURNER'S PROCESSION AND PUBLIC CIRCULATION	75
MODEL IMAGES	76
CONCLUSION	78
REFERENCES	79

ACKNOWLEDGMENTS

To my advisors, David Miller and Ken Tadashi Oshima, thank you for the encouragement, knowledge, guidance and time you have given me throughout this thesis process. To the Scan | Design Foundation for the generous fellowship, which funded my studies in Denmark.

Additionally, to my friends and family, thank you for your endless support and efforts to keep me grounded.

Finally, to Michael Beveridge, thank you for everything you have done for me. This degree would not have been possible without you.

LIST OF FIGURES

FIGURE 1	Life and Death by Gustav Klimt	ii
FIGURE 2	Rendering of a city, a cemetery, and everyday life in one place	3
FIGURE 3	Copenhagen Stroget walking street with bicyclists	5
FIGURE 4	Japanese pagoda	5
FIGURE 5	Mexico City Teotihuacan Ruins	5
FIGURE 6	Assistens Kirkegård, strollers of picnicking families in the cemetery	6
FIGURE 7	Hanami Festival in Aoyama Cemetery	6
FIGURE 8	Day of the Dead Celebration in Mexico City	6
FIGURE 9	To This Favour by William Michael Harnett, 1879	8
FIGURE 10	The Dance of Death by Michael Wolgemut, 1493	8
FIGURE 11	Tate Modern Website game about Memento Mori in Art	9
FIGURE 12	Steven Hirst's "The Physical Impossibility of Death in the Mind of Someone Living"	9
FIGURE 13	Sally Mann's "What Remains" exhibit photo	10
FIGURE 14	Sally Mann's "What Remains" exhibit photo	10
FIGURE 15	Cimetière des Innocents in 1550	13
FIGURE 16	Plan of Père Lachaise	14
FIGURE 17	Père Lachaise	15
FIGURE 18	Mount Auburn Cemetery in Cambridge. Founded in 1831	17
FIGURE 19	Forest Lawn Cemetery, Glendale, CA. Founded in 1913	17
FIGURE 20	Trinity Church in New York City, 1846	18
FIGURE 21	Christ Church in Cambridge, burial ground established in 1660, church in 1809	18
FIGURE 22	St. Philips Episcopal Church, Charleston, SC 1681	18
FIGURE 23	Funeral procession, Red House Farms, West Virginia, 1935	19
FIGURE 24	Funeral of Herman Rosenthal, New York, NY 1912	19
FIGURE 25	Images of Seattle Funeral Homes	20
FIGURE 26	Cenotaph at Whitehall	23
FIGURE 27	Vietnam War Memorial	23
FIGURE 28	Obon Festival	26

FIGURE 29	Obon Festival	26
FIGURE 30	Hanami Festival in the cemetery	27
FIGURE 31	Picnicking in the cemetery	27
FIGURE 32	Mexico's Day of the Dead	28
FIGURE 33	Zocalo Panteon Day of the Dead Celebration	28
FIGURE 34	US Cremation Rates Map	30
FIGURE 35	View of Crematorium at Vestfold	32
FIGURE 36	Vestfold Crematorium. View for visitors	32
FIGURE 37	Seattle Funeral Home	34
FIGURE 38	Seattle Funeral Home	34
FIGURE 39	Chart of religious affiliations in King County from the Association of Religious Data Archive	35
FIGURE 40	Pew Research Center Chart	35
FIGURE 41	Pew Research Center Chart	35
FIGURE 42	Path to the Chapel of Resurrection	36
FIGURE 43	Way of the Cross	36
FIGURE 44	Granite Cross	37
FIGURE 45	Igualada Cemetery path	38
FIGURE 46	Igualada Cemetery	38
FIGURE 47	Igualada Cemetery - Site Map with circulation flanked by columbarium wall	39
FIGURE 48	Axonometric of Kaze No Oka. Diagram of pause and procession. Each pause is a separation of the program spaces.	40
FIGURE 49	Kaze no Oka - Exterior View	41
FIGURE 50	View of the Reflection Pool	41
FIGURE 51	View of pool zoomed out.	41
FIGURE 52	Bike path through the cemetery	42
FIGURE 53	Danish family picnicking in the cemetery	42
FIGURE 54	Map of Site and Belltown neighborhood boundaries	47
FIGURE 55	Denny Regrade Remnants of Denny Hill.	48
FIGURE 56	View of Belltown today where Denny Hill once stood	48

FIGURE 57	Unocal Brownfield, what is now the Olympic Sculpture Park	48
FIGURE 58	Olympic Sculpture Park	48
FIGURE 59	site reading montage	49
FIGURE 60	Existing site section	49
FIGURE 61	Photos of site's existing parking structure	50
FIGURE 62	Rendering of site with new design	51
FIGURE 63	site plan	51
FIGURE 64	Rendering of design as viewed from the Olympic sculpture park standing facing the wake. To the left of the wake lies in entrance to the Columbarium Tunnel where mourners can access the park and the public can access the tunnel and pier.	52
FIGURE 65	Rendering of the Memorial Site as viewed from the bridge over Elliot Ave.	53
FIGURE 66	Rendering of the Digital Media Library	55
FIGURE 67	Program Diagram	56
FIGURE 68	User groups organized in relation to their interaction	56
FIGURE 69	Rendering of Entrance Hall where mourners arrives and collect themselves before entering into the building	60
FIGURE 70	Ceremonial Path - As mourners wait for the ceremony, areas to reflect are provided. The window in the center of the rendering overlooks Elliot Bay with a view of the pier	61
FIGURE 71	Rendering of the Ceremony Hall and view of the atrium space that brings light into the space	62
FIGURE 72	Rendering of the Reflection Room	63
FIGURE 73	Rendering of the Reflection Room where the ashes are collected. The entrance to the columbarium tunnel is located to the left (not shown)	64
FIGURE 74	Rendering of the Columbarium Tunnel. The Tunnel opens up to the pier	66
FIGURE 75	Rendering of Pier in relation to the building (to the right). View is taken from the adjacent existing pier (shown in the site map)	67
FIGURE 76	Resomation process	68
FIGURE 77	Roof Plan	69
FIGURE 78	First floor above grade at Western Ave	69
FIGURE 79	Ground plan at Western Ave.	69

FIGURE 80	First floor plan below Western Ave	70
FIGURE 81	Ground plan at Elliot Ave.	70
FIGURE 82	Plan at Tunnel level	70
FIGURE 83	Longitudinal Section facing East	71
FIGURE 84	Longitudinal Section facing West	71
FIGURE 85	Site Circulation	72
FIGURE 86	Circulation diagram	73
FIGURE 87	Photo of full model	74
FIGURE 88	Photo of building section with the model pulled apart to reveal the section	74
FIGURE 89	Photo of tunnel modeled pulled apart to reveal the columbarium wall	75
FIGURE 90	Photo of tunnel and light wells to reveal spatial quality	75
FIGURE 91	Photo of model pulled apart to reveal the path that connects the park to the tunnel for public access. View is taken from building to the park.	75
FIGURE 92	Photo of model from the park to the path towards the building and tunnel. From the wake visitors can enter the site to go to the tunnel	75

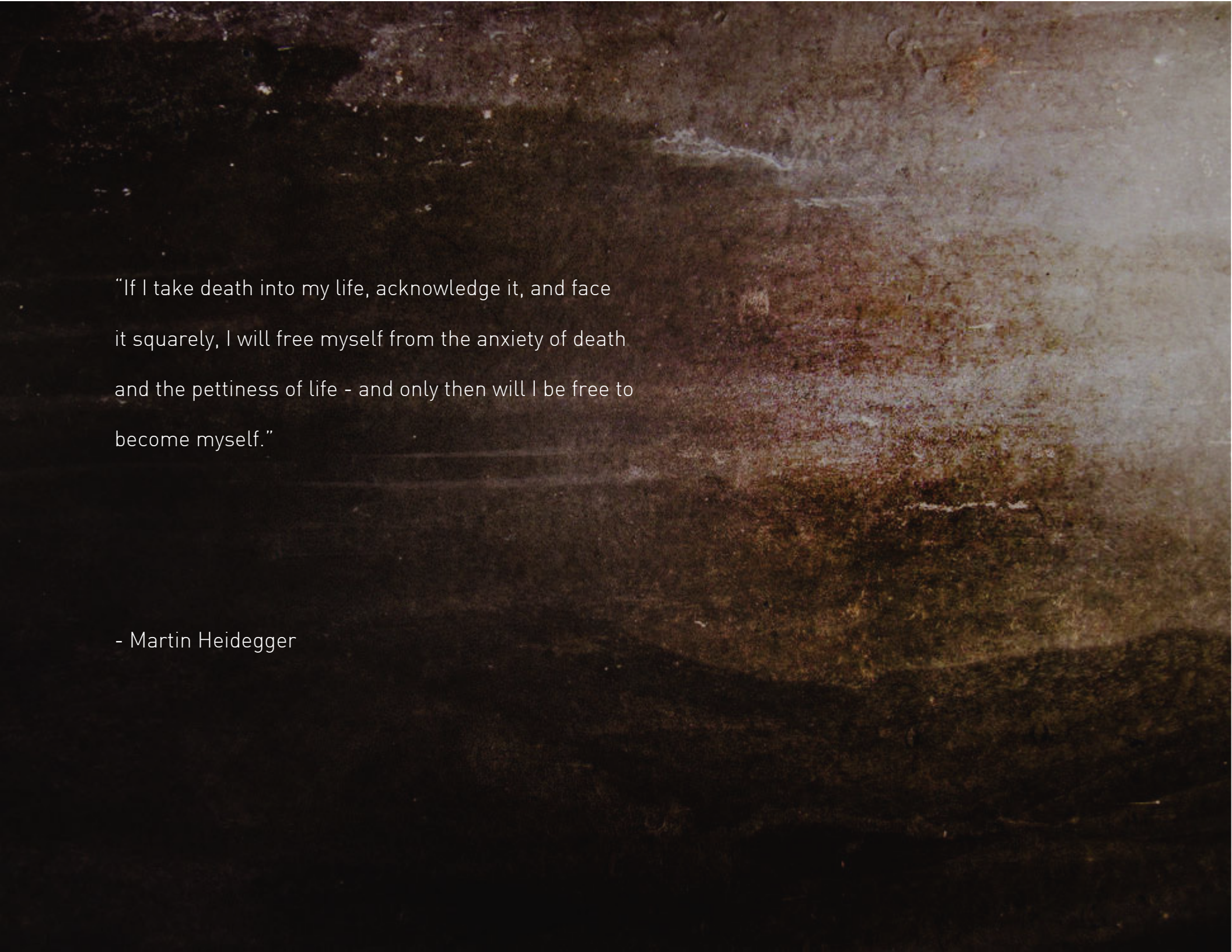

“If I take death into my life, acknowledge it, and face
it squarely, I will free myself from the anxiety of death
and the pettiness of life - and only then will I be free to
become myself.”

- Martin Heidegger

I N T R O D U C T I O N

“When we find a mound in the woods, six feet long and three feet wide, raised to a pyramidal form by means of a spade, we become serious and something in says: someone was buried here. That is architecture.” – Adolf Loos, “Architecture”

Monuments and memorials function to communicate and preserve the memory of a place, its cultures and its people. Memories and experiences give meaning to these architectural spaces and therefore require some examination for the purpose this thesis. Most memorials are placed in public spaces and built with the intention of remembering a person, group of people or significant event in history. These structures vary in scale and ranging from a small gravestone in a cemetery to remember a single person to large-scale war memorials to commemorate those who have died a war. We also memorialize honorees through plaques, street signs, building dedications and moments of silence. Memorials are a public reminder of who we are and where we have come from. Monuments, for the purpose of this project are defined as the object of remembrance. A memorial incorporates the use of a monument (or several monuments) “to memorialize the life or event that persons may wish to perpetuate in memory”¹. However, it is of note that monuments do not necessarily refer to the death of a person or group of people. Structures with historical significance due to their size, age and location may also be considered a monument, such as the Statue of Liberty or the Eiffel Tower.

1 “USAMonuments.com & ValdostaMemorials.com”. Web. 19 June 2013

Cemeteries, then, can be viewed as a collection of memorials of persons associated with a particular city or town on public or private ground. Moreover, funerary architecture and cemeteries reflect a culture's religious beliefs, social structure, and differences as well as the evolution of these matters over time. They inherently become a physical archive of the city's history, "a book to be read by those who wish to understand something of the lives and aspirations of the people who have lived and gone".² Lewis Mumford states in his book, *The City in History*: "The city of the dead antedates the city of the living. In one sense, indeed, the city of the dead is the forerunner, almost the core, of every living city."³

In North America, the cultural response to death is to enclose it within cemeteries, banish it to the peripheries of the urban experience or conceal it within funeral homes. This isolation deprives urban centers and their inhabitants of a vital civic space dedicated to acts and rituals associated with death. Distanced and forgotten from daily life, these places of remembrance are not seen as cultural resources for the communities in which they reside. This distancing of death from daily life has affected the human ability to resolve death and dying.

With the current preference of cremation over ground burials and the increase of secularization of the population in the US, arises an opportunity to reconsider the location and design of memorial spaces.

"The neglected cemeteries, poorly designed crematoria, and abysmal tombstone designs of the present insult life itself, for death is an inevitable consequence of birth. By treating

2 Worpole, Ken. *The Cemetery in the City: A Report*, p.10

3 Mumford, Lewis. *The City in History: Its Origins, Its Transformations, and Its Prospects*, p. 7



FIGURE 2 Rendering of a city, a cemetery, and everyday life in one place

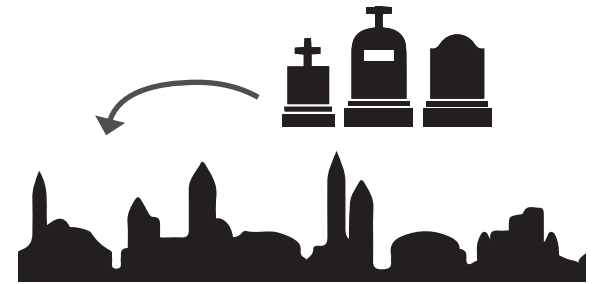

the disposal of the dead as though the problem were one of refuse-collection, society devalues life. The architectural memorials of great cultures are works that, by their sublime equalities, express something of the infinite. Such architecture transcends the prosaic. Creativity and vigor characterize a true celebration of death. We can learn much from the funerary architecture of the past if we are to give new significance to a celebration of life in our time.”⁴

4 Curl, James S. *A Celebration of Death: An Introduction to Some of the Buildings, Monuments, and Settings of Funerary Architecture in the Western European Tradition*. p367

THESIS STATEMENT

“No people who turn their back on death can be alive. The presence of the dead among the living will be a daily fact in any society which encourages its people to live.

— Christopher Alexander, “A Pattern Language”

An important part of the way we live depends on our attitudes towards death and the dead. Architecture is responsible for providing the context in which these human experiences can find a place. The city must provide a space and a way for the living to interact and resolve relationships with the dead. This thesis explores the potential for architecture to contribute to the spaces where life and death intersect, enabling each to enrich the human experience by charging our everyday lives with the emotional power that comes from awareness of our own mortality. I propose a reinsertion of memorial spaces into the core of the city of Seattle in order to restore the living’s connection to the dead by replacing the cemetery landscape, spaces that are rarely visited, into spaces woven into the urban experience.

This thesis will examine different death rituals, customs and traditions and the civic spaces that facilitate them. Specifically, I will be looking at Scandinavian, Japanese and Mexican rituals and customs. These three cultures were chosen in an attempt to combine my academic experiences abroad: my year abroad studying at the Royal Danish Academy in Copenhagen, the BE Lab travel to Japan and the Mexico abroad studio. The project is a culmination of graduate education and experiences. From these experiences abroad I was able to scratch the surface of understanding of their spectrum of death rituals and cultural attitudes towards death, which informed the final design of the project.

Scan|Design

BE LAB 

Mexico Studio



FIGURE 3 Copenhagen Stroget walking street with bicyclists



FIGURE 4 Japanese pagoda



FIGURE 5 Mexico City Teotihuacan Ruins

Denmark

Japan

Mexico



FIGURE 6 Assistens Kirkegård, strollers of picnicking families in the cemetery



FIGURE 7 Hanami Festival in Aoyama Cemetery



FIGURE 8 Day of the Dead Celebration in Mexico City

Scandinavian and Japanese urban cemeteries are used as public parks for activities such as picnicking or running. In this case, one is surrounded by death while doing bodily actions in the cemetery, eating running, napping, actions that are so banal, yet connect us to our bodies, make us slightly aware of ourselves and connects us to our aliveness. Many reasons why these behaviors in cemeteries are not considered taboo or inappropriate relate to the cultural attitudes towards death and dying that are shaped by religious beliefs and cultural norms. Scandinavia's more secular attitudes towards death tend to rely less on religious rituals, including burial. Instead, there appears to be more openness towards post-death alternatives, including cremation. In Japan, new ideologies of death have emerged as well as trends in diversifying mortuary practices and finding alternatives to interment in order to address contemporary

concerns for existing practices. “Today, both funeral professionals and ordinary people talk about having mortuary ceremonies that recall the dead person’s individual characteristics making these ceremonies occasions of central importance for the deceased.”⁵ Mexicans have had a death fascination that dates back to pre-Columbian times and continues to shape contemporary attitudes toward life. This intimacy with death and the rituals that celebrate their dead have become a central part of Mexico’s identity. Further examination of each culture’s death rituals and their evolution as they pertain to this thesis will be discussed in later chapters. Examining different cultural responses to death and the rituals that use public space will bring a rich understanding, new perspective and reference to how spaces for memorializing the dead may take shape in the city. As the U.S. population grows increasingly diverse, the need to accommodate differing ways in which we ritualize and memorialize the dead. The design of public spaces can and should host diverse cultural celebrations of death and remembrance.

This thesis focuses on the secular population, instead of creating a space for all religions. Currently, society provides for religious, sacred spaces whereas those without religious frameworks are lacking. Situated in Seattle, the project seeks to address the city’s growing population of members that have no religious affiliation or do not identify with one particular sect. It is the goal of this project to celebrate the notion of life & death through the choreography between building and landscape to enhance the site’s presence in the urban environment, so that the project may stand as a constant reminder of mortality and life, a memento mori in the city.

5 Kawano, Satsuki. *Nature's Embrace: Japan's Aging Urbanites and New Death Rites*. p.14



FIGURE 10 To This Favour by William Michael Harnett, 1879



FIGURE 9 The Dance of Death by Michael Wolgemut, 1493

MEMENTO MORI

Memento mori have a long history in art, architecture and photography. Translated as, “Remember your mortality” or “Remember you will die”, Memento mori are images created and displayed to remind us of our mortality. They encourage one to meditate on death, to reflect on the impermanence of life, and, so, to live a meaningful and virtuous life. “A typical memento mori image would contain symbols that would remind the viewer of death and mortality, items such as skulls, clocks, sundials, hourglasses, extinguished candles and other perishable goods.

“A sub-genre of memento mori art is the Danse Macabre, or Dance of Death. These paintings typically portray a skeleton (signifying Death or the Grim Reaper) walking, dancing, or playing music with figures of all ages and walks of life to the grave to express the universality of death. Dance of Death art, which also appears in literature, grew out of the horrors of that time: famine, the Hundred Years War, and, most of all, the Black Death.”⁶ The popularity of these images and artifacts are a reflection of the people’s fascination of death, its consumption in everyday life and a historical record of its ethos. “The records that civilizations and craftsmen have left in funerary art and architecture clearly expresses the attitudes about the only experience in life we may be absolutely sure will come to us.”⁷

6 McKay, Brett and Ann. “Memento Mori: Art to Help You Meditate on Death and Become a Better Man”

7 Curl, James Steven. *A Celebration of Death*, p.1

Despite changes in representational content and in popularity over time, memento mori continue to appear in contemporary art. The Tate Modern in London, for example, has an online children's game titled "Memento Mori Room" to teach the significance of still life in painting but also to introduce mixed media work such as Hirst's "Forms without life".

Death is the central theme for the contemporary British artist, Damien Steven Hirst, with a series of skulls depicted in paintings and sculpture, a book titled from the "Cradle to the Grave" and one of his most famous pieces titled, "The Physical Impossibility of Death in the Mind of Someone Living".

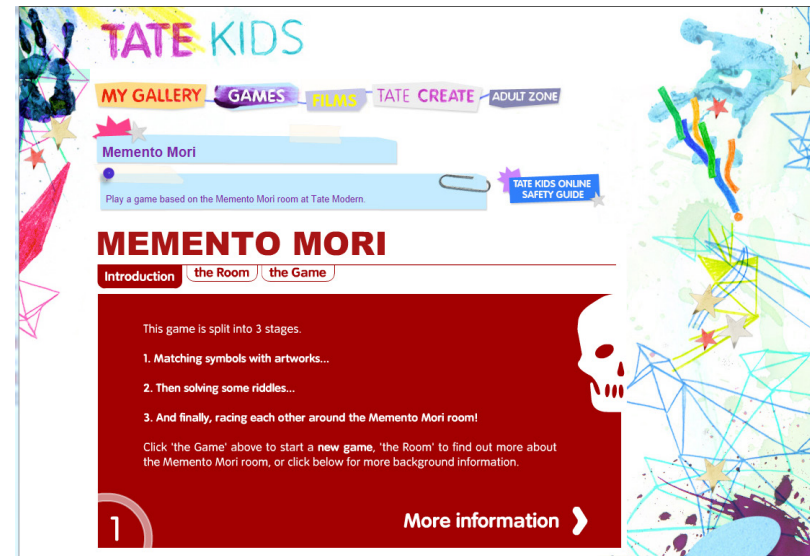

FIGURE 11 Tate Modern Website game about Memento Mori in Art

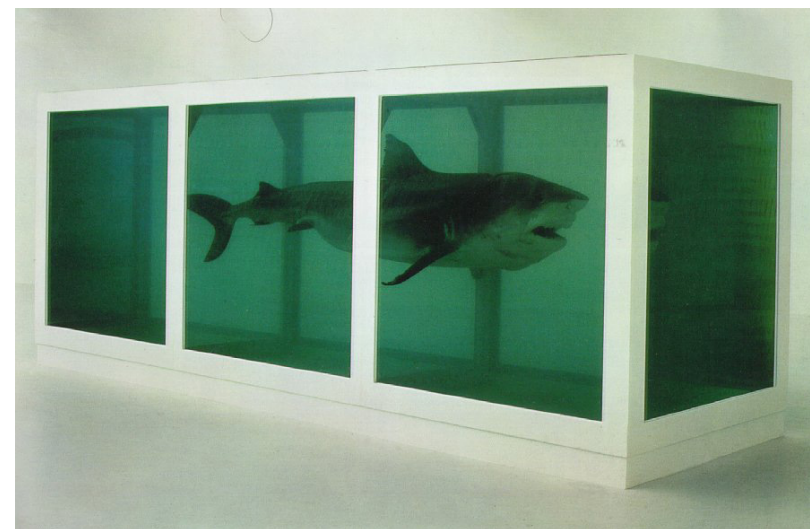

FIGURE 12 Steven Hirst's "The Physical Impossibility of Death in the Mind of Someone Living"



FIGURE 13 Sally Mann's "What Remains" exhibit photo



FIGURE 14 Sally Mann's "What Remains" exhibit photo

Sally Mann, an American photographer, explores the concept of memento mori in a recent exhibition title, "What Remains", a study of decaying bodies at an anthropological facility often called, "body farms." These images of decomposed bodies in their setting are Mann's attempt to show death as a natural cycle of life and to make it a part of our daily dialog. She states, "There's a new prudery around death. We've moved it into hospital, behind screens, and no longer wear black markers to acknowledge its presence. It's become unmentionable."⁸

A simple search on the Internet will produce numerous hits of galleries and museums announcing exhibitions on the topic of memento mori. The expressions of memento mori from contemporary artists signify a shift in the focus of the exploration of death and dying in contemporary art.

DEATH IN AMERICA

We confront death daily via television, movies, or video games, but for the most part we do to be distracted or entertained. In a country where death is so prominent in popular culture, why is it hard to comprehend the reality of death, particularly as it pertains to one's self? Culturally, we do not bother with notions of death until it affects our lives when we lose a loved one. We push death and dying from the center of family and community to the edges of society. In the US, death

⁸ Morrison, Blake. *The Guardian UK*. May 28, 2010.

typically occurs in the institutional environments of hospitals and nursing homes, when it once occurred in the homes of family members. Moreover, we have professionalized death. David E. Stannard in his book titled, *Death in America*, states, “Death is thus avoided as much as possible, and when it is no longer possible – it is turned over to professionals who provide their own special skills in the effort of denial.”⁹ While philosophers, artists and poets dance with the dark attraction of death, in everyday life we want to push all thought of it aside.

Social and scientific realities continue to shape our perceptions of death; and advances in Western medicine further complicate the Interpretation and experience of death and dying. Attempts to prolong life and distance death through these medical advances means that dying is less frequently experienced.

“We arrange for the marvels of modern medical care, because, to be sure, we desire the recovery of the sick but also because these devices offer us a means of avoiding sickness, aging, and dying. In the language of sociologists, the manifest function of our cadre of experts in the helping professions is to provide the critically ill with better cure and care, but a latent social function of this specialization is the avoidance of an event with which we cannot cope.”¹⁰

In contemporary culture, we are left with two basic responses to the events of death; on the one hand, the complete avoidance and denial of death, and on the other, the preoccupation of death

9 Stannard, David E. *Death in America*. P.viii

10 Mack, Arien. *Death in American Experience*. p. 102

as portrayed in the media as tragic, catastrophic events. The contemporary condition of death in the US highlights a decreasing clarity as to what roles the living has in rites and rituals of care, disposal of the deceased and the memorialization of the passing. As death is further obscured and denied in our culture, its exploration and examination of the existing rituals becomes increasingly valuable and pertinent.

EXISTENTIALISM AND DEATH

Many say that existentialism is difficult to define. This might be because the founders of existentialism differ dramatically and contradict one another. A simplified definition of existentialism might take it to be an approach to understanding human existence and experience with the purpose of increasing one's self awareness. One theme in existentialist thought is the notions of Being and Nothingness (nothingness as death) as discussed in Heidegger's "Being and Time"¹¹. Existentialists view the awareness of death as the basic human condition, which gives significance to living. The fear of death and the fear of life become interrelated. Heidegger claims that art has the power to reveal more of the truth of oneself and one's relationship to Being. Works of art have the ability to bring one home to oneself; they reveal how man dwells together in the midst of things and allow man's own existence to be viewed again as something fresh and strange.¹² Existential contemplation, and the remembrance of the dead, has been a theme of the architects of the architecture of death, Enric Miralles, Gunnar Asplund, and Aldo Rossi, for example.

11 Heidegger, Martin. *Being and Time*. New York: Harper, 1962.

12 Polt, Richard: *Heidegger: An Introduction*. p. 136

A HISTORY OF THE CITY AND CEMETERY

Historical examination of the relationship between city and the cemetery illustrates the fluctuating nature of their locations. Historically, the locations for burying the dead have alternated between being a part of the city center and removed from the city boundaries.



FIGURE 15 Cimetière des Innocents in 1550

WESTERN EUROPE

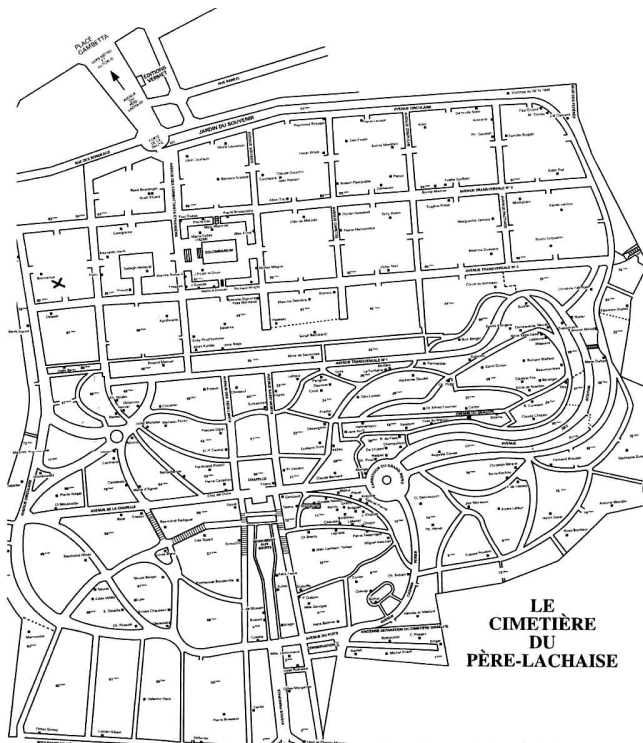

FIGURE 16 Plan of Père Lachaise

During the Middle Ages, the first burial ground, Cimetière des Innocents, was established. Functioning also as a marketplace, it was a subtle relationship that blurred the boundaries between the living and the dead. The marketplace cemetery combined the living with signs of Memento Mori. Skeletal remains were exhumed and fashioned to adorn the surrounding walls of the cemetery that served as distinct reminders of human mortality.¹³ The Cimetière des Innocents was brought to its end by the Parisian Cemetery Reform of the 18th Century. This was due the overcrowding burials, which inevitably caused hygienic problems and creating a rise in sanitary concerns.¹⁴

Built in 1804, Père Lachaise became the first metropolitan garden cemetery, laid out to the east of Paris as a response to the overcrowding in city cemeteries. In contrast with urban burial plots, Père Lachaise was imagined as an idealized landscape, its curving pathways designed for promenades.¹⁵

“The changes in the image of the cemetery were related not only to the cemetery proper but also to the bond of the living and the dead. The new cemeteries were to be located outside of the city but they were not to be shunned. Unlike cemeteries today, they still played an important role in spiritual and life.”¹⁶

The plan of the cemetery illustrates grand boulevards around the periphery of the cemetery with winding paths that function like streets in a city. “The cemetery (of Père Lachaise) has an urban

13 Etlin, Richard A. *The Architecture of Death: The Transformation of the Cemetery in Eighteenth-Century Paris* p6.

14 *ibid.*p36

15 *ibid.*321

16 Etlin, Richard A. *The Architecture of Death: The Transformation of the Cemetery in Eighteenth-Century Paris*,p 39



FIGURE 17 Père Lachaise

quality, with paved streets lined with house-tombs. The streets are named and signed, with cast-iron furniture similar to that of streets in the cities of the living.¹⁷ The mirroring of the city image in the cemetery along with its picturesque landscape contributed to its popularity and created a new image for death and the cemetery.

NORTH AMERICA: THE NEW LAND

The Pere Lachaise was an influence on the rural cemeteries in the US, the first being Mount Auburn Cemetery in Boston built in 1831.

This new cemetery type grew in popularity along the eastern states and eventually spread to the rest of North America.¹⁸ The park-like characteristics illustrate the attempts to mimic the experience of a place for contemplation. The rural cemetery removed the burial of the dead from the center of the town to the periphery of country. Michel Foucault wrote about this shift in his work, *Of Other Spaces*, he states, "The cemeteries then came to constitute, no longer the sacred and immortal heart of the city, but the other city, where each family possesses its dark resting place."¹⁹ Later in the late nineteenth century, the lawn cemetery or memorial park offered a greener iteration of the cemetery outside of the city. The first of this kind was the Forest Lawn in Glendale, CA built in 1913, which has now become the standardized cemetery.²⁰ Still

17 Curl, James S. *A Celebration of Death:...*, p.160

18 Eggener, Keith. *Cemeteries* p.92

19 Foucault, *Of Other Spaces, Heterotopias*.

20 Eggener, Keith. *Cemeteries* p.111



FIGURE 18 Mount Auburn Cemetery in Cambridge. Founded in 1831

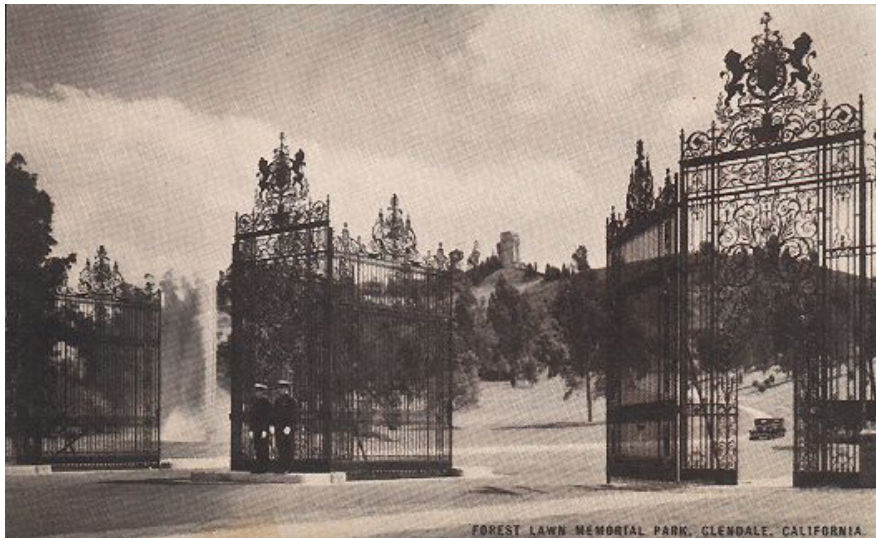
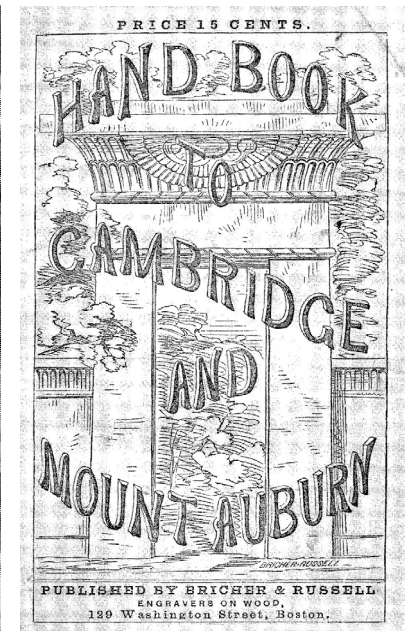

FIGURE 19 Forest Lawn Cemetery, Glendale, CA. Founded in 1913



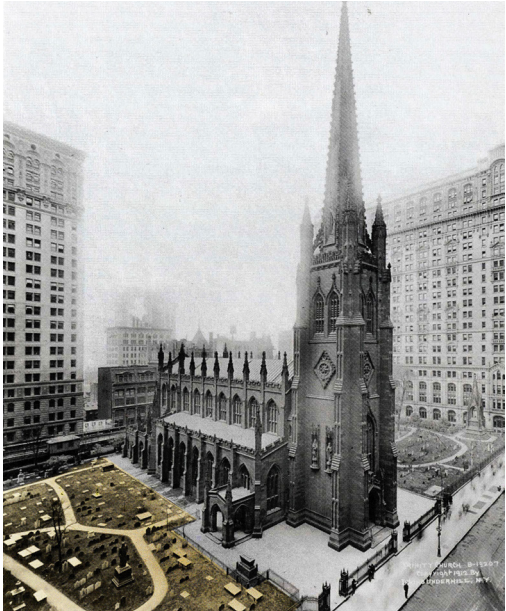

FIGURE 20 Trinity Church in New York City, 1846



FIGURE 21 Christ Church in Cambridge, burial ground established in 1660, church in 1809

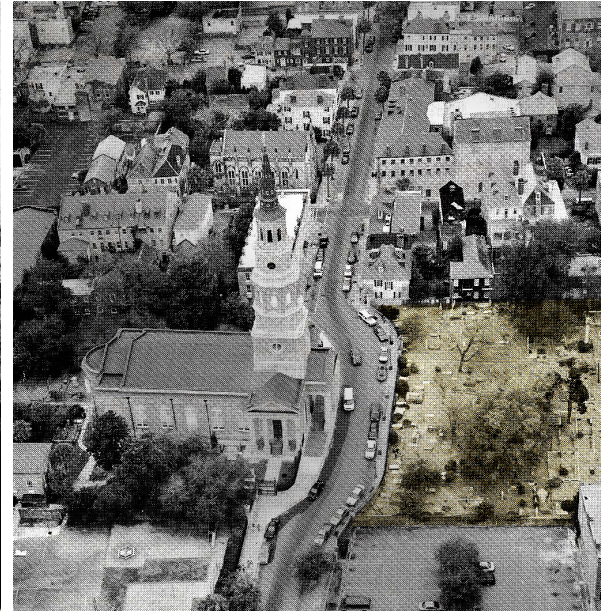

FIGURE 22 St. Philips Episcopal Church, Charleston, SC 1681

intended as a destination for contemplation, the lawn cemetery standardized cemetery practices in the US. "Preferences for an unobstructed landscape over the presence of grave stones and monuments which directed attention to the dead, the grave markers were eventually eliminated and replaced by inset stones on a grave, removing the symbols of death and contributing to the general development of the dying of death."²¹

A DEATH IN THE COMMUNITY

A community's way of experiencing death and the cemetery wasn't always a vast landscape in North America. In fact in the first established cities, the cemetery was associated with the church yard which was the center of the town. Trinity Church, in the center of Manhattan, NY and initially a Dutch burial ground, for example, established this graveyard in 1697.²² These church graveyards were adjacent to everyday life and in the heart of the city. One could imagine the church bells ringing as a funeral ended. The sound would resonate throughout the city. Additionally, the funeral procession would occur in the city streets. Whether in a smaller rural setting or on the wide streets of New York City, the funeral was seen by all in the community and would affect those that viewed the procession.

²¹ Farrell, James J. *Inventing the American Way of Death, 1830-1920*. 121-123

²² Eggener, Keith. *Cemeteries*. p.41



FIGURE 23 Funeral procession, Red House Farms, West Virginia, 1935



FIGURE 24 Funeral of Herman Rosenthal, New York, NY 1912



FIGURE 25 Images of Seattle Funeral Homes

THE RISE OF THE AMERICAN FUNERAL HOME

The environment shift from death in the home to funeral home began at the turn of the twentieth century with the rise of the hospital, the practice of embalming, and changes in demographic patterns. Prior to this, people were often buried on family property under the care of family members. The beginning of the twentieth century saw a decrease in mortality rates and increase in life expectancy. "As the health of the social body began to change, hospitals became the primary institutions to care for the sick and monitor the passage from life to death."²³ "Funeral homes were later established to relieve the family of the logistical problems presented by a death."²⁴ Increased mobility and the dispersal of families created further need for funeral homes. The industry accommodated this by providing communal space capable of accommodating large groups when families are spread out nationally or internationally. The practice of embalming and desire to view the deceased prior to burial legitimized the need for the funeral director and home. Furthermore, personalized and secular beliefs necessitated a place that was not distinctly affiliated with the traditional Sacred but provided a space for self-expression of the rite of passage of death. The resemblance of home in a residential setting, the funeral home as contemporary spaces of death attempts to reconcile this removal of death and dying from the family house by obscuring the death on the exterior and making the interior spaces seem familiar and comfortable.

23 Laderman, Gary. *Rest in Peace a Cultural History of Death and the Funeral Home in Twentieth-Century America* p.3

24 (<http://www.funeralwise.com/learn/industry>)

THE WAR MEMORIAL

Historically, the war memorial was erected to commemorate great victories in war, e.g. the Arc De Triomphe, but more recently the intent of the war memorial is to honor those who have died. Whether a statue, a place, a building, or a combination of these and other elements, a war memorial is a social and physical arrangement of space and artifacts to keep alive the memories of persons who participated in a war sponsored by their country.²⁵ Memorials help to sustain the spiritual origins of a society and its visibility in the public realm is crucial in its accomplishment. The war memorial serves as a physical remembrance of a collective past in order to bring an understanding of the present and a frame of reference for the future.

“Memorials that perform public service emphasize both sacredness and utility and reinforce the values and aims represented by the sentiment of commemoration through their public purpose. In this century, the public has called for memorials that provide a community service rather than ones that have only symbolic and aesthetic meaning.”²⁶

The war memorial, as a symbolic reminder of a historical event and those that lost their lives as a result, provides a social service for that community and intrinsically transforms collective identity. The social function of the war memorial should extend to the individual within a given community. A memorial site for those who lived in Seattle provides a similar service to that of a war memorial. It functions to serve the community in reconciling with the human condition, bringing meaning to the present and influencing the future.

²⁵ Barber, Bernard. *Place, Symbol and Utilitarian Functions in War Memorials*, *Social Forces* 28 (1949): 64-68.

²⁶ *Ibid.*, p. 46-53.



FIGURE 26 Cenotaph at Whitehall



FIGURE 27 Vietnam War Memorial

DEATH IN THE LENS OF OTHER CULTURES

The following section will consider different cultural rituals and attitudes towards death. The topics will only pertain to the subject matter of this thesis and by no means are an exhaustive analysis or description of the complexities of each culture. Reflection on other cultural responses to death will provide new perspectives as a means to understand our positions regarding death and dying. Before examining the differences between each, it is imperative to consider: "Where does the concern with death originate? It is reasonable to believe that this exclusively human question arises from another typically human trait: the capacity for self awareness."²⁷ How does this line of questioning inform our cultural understanding of mortality? How does that relate to our understanding of our own community? Of society?

SCANDINAVIA²⁸

Cemeteries in Scandinavia, such as Woodland Cemetery in Stockholm, Sweden and Assistens Kirkegård, Copenhagen, Denmark are frequently used as parks for recreational purposes. Not that this is unique to Scandinavia, but the examination into the attitudes towards death sheds light into why this practice is acceptable and not offensive. Denmark and Sweden are considered the healthiest and happiest countries in the World. They are also known for being the least religious. Most religious rituals and practices,

²⁷ Stannard, David E. *Death in America*.p.92

²⁸ Due to the resources used for this research, reference to Scandinavia is in reference to Denmark and Sweden only as the research found only discusses these two countries.

getting married in a church, being members of a church, burying the dead in a cemetery or baptizing children are not performed in these countries because of religious reasons, beliefs or convictions. "Rather, Danes and Swedes overwhelmingly engage in these Christian rituals out of a sense of cultural tradition."²⁹ Religious rituals are practiced not because of a firm belief in God or because of a doctrine for an assurance of a good afterlife. These rituals are performed because of the resilient history within its culture; a history that defines the contemporary identity where the meaning of these rituals is completely gone. The Danes and Swedes do not contemplate death, nor do they believe in the existential quest to find meaning in life.

Additionally, most Danes and Swedes don't believe in life after death, most people don't fear death, and the overall degree of worry about death is relatively minimal.³⁰ This would explain in general the lack of any death anxiety found in the two cultures. Without death anxiety, there is no reference to the cemeteries as a sacred place. This brings an interesting perspective to the idea of a cemetery as an equivalent space for recreation. Though the Danes and Swedes do not share these strong religious beliefs or fear of death and dying, they do not live in apathy or indifference. They care about politics, the general social well being of their neighbors, and participate in their community. There is a general belief that religion brings order and discipline, especially in the US but the Danes and Swedes have shown that a healthy quality of life, without the religious rules, is easily accomplished when committed and involved citizenry is present.

29 Zuckerman, Phil. *Society Without God: What the Least Religious Nations Can Tell Us About Contentment*.p.8

30 Ibid, p.65



FIGURE 28 Obon Festival



FIGURE 29 Obon Festival

JAPAN

Attempting to describe all the complexities surrounding death, dying, ceremony and memorialization in Japanese culture is beyond the scope of this project and research. There have been many evolutions and trends in the disposing of the dead and the ceremonies that surround the event. Historically, the rituals and ceremonies for death have been based on Shinto and Buddhist practices and beliefs. There has been a shift, however, from the family and community funerary rituals to commercial funeral ceremonies manifested in the commercialization and professionalization of the funeral.³¹ Moreover, “in contemporary Japan the dead are cremated not necessarily because of Buddhist influences, but because of the modernist embrace of cremation since the Meiji period.”³² The new trend in Japan is the scattering of ashes and the personalization of ritual. Similar trends can be seen in many countries as well as in the US. What will be discussed for the purpose of this thesis however, are the tradition of Obon and the use of cemeteries in the city as tourist attractions and recreational destinations.

Obon, the Festival of Dead, also called the Festival of the Lanterns, is a three-day Buddhist tradition, which commemorates the spirits of their ancestors. The Japanese believe that the spirits come back to their homes to be reunited with their family during the time of Obon and is considered a very sacred and important time of the year. The Japanese visit the graves of their ancestors and pay their respects

31 Kawano, Satsuki. *Nature's embrace Japan's aging urbanites and new death rites* p.78

32 Ibid. p80

to the recently departed. The Bon Odori dance festival held outdoors and accompanied by traditional music, is a celebration to welcome the ancestors back to this world.³³

What is relevant of this ritual is that it is the celebratory act of remembering those who have died in a festive manner. It is a reflection of the cultural attitude towards death. "For the Japanese, death is not an end, but rather a stage in the eternal progression from ancestors to future generations. It is a door that is not the end, but the beginning."³⁴

The Hanami Festival, or cherry blossom festival is an important Japanese custom. The blooming of cherry blossoms signifies not only the arrival of spring but they become symbols of a bright future. The cherry blossom or *sakura* has been a symbol of 'the cycle of life, death and rebirth, on the one hand, and of productive and reproductive powers, on the other' throughout the history of Japan. The trees have been used as symbols for everything, from predicting successful harvests of rice to giving the World War II kamikaze pilots courage for their one-way missions.³⁵ The cherry blossom festival is celebrated all over Japan. In Tokyo, a famous place to picnic for the festival is the Aoyama Cemetery. Today, this festival has a major tourist draw, where cemeteries are full of picnickers and people strolling through them. Using the cemetery as park for such a festival parallels the Scandinavian attitude discussed earlier but is not a direct comparison. One can argue that the celebration of the cyclical nature of life, death, rebirth and renewal brings a healthy attitude towards our own mortality as a part of that natural cycle.

33 Krasno, Rena, and Toru Sugita. *Floating Lanterns and Golden Shrines: Celebrating Japanese Festivals*. P. 10

34 Albrecht Fürst von Urach, *Das Geheimnis japanischer Kraft*

35 Ohnuki-Tierney, Emiko. *Kamikaze, Cherry Blossoms, and Nationalisms: The Militarization of Aesthetics in Japanese History*.p11-14



FIGURE 30 Hanami Festival in the cemetery



FIGURE 31 Picnicking in the cemetery

MEXICO



FIGURE 32 Mexico's Day of the Dead



FIGURE 33 Zocalo Panteon Day of the Dead Celebration

"Life and death are inseparable, and when the former lacks meaning, the latter becomes equally meaningless. Mexican death is the mirror of Mexican life."

- Octavio Paz, *"The Labyrinth of Solitude"*

Mexico's preoccupation with death dates back to its pre-Columbian history associating the pre-Hispanic rituals with the contemporary celebration of the Day of the Dead.

Death in Mexican culture is not feared by rather celebrated. Images of death can be seen and experienced in everyday life in the city, from the art, music and literature to the souvenirs sold to tourists. "The Mexican acceptance of death is perhaps best understood by observing the almost infinite collection of toys, which are inspired by it, and which are intended purely to give pleasure to children."³⁶ This integration of death imagery permeates through many traditions, festivals and everyday life and expresses Mexico's unique philosophy of living and dying.

The Day of Dead celebrations consist of several activities that extends long into the night and continues on to the next day. Food preparation and consumption plays a vital role in the celebrations. Special sugar sculptures resembling human skulls and decorated with bright colors are produced and given as gifts. Pan de muerto, or bread of the dead is produced to resemble bones and added to other meals prepared for the dead to bring to the cemeteries for the ritual.

Families bring flowers and meals and spend the entire evening in the cemeteries and sleep on the

³⁶ Stannard, David E. *Death in America*.p.111

graves. The families then eat the food the next morning.³⁷

“It is worth reflecting upon the significance of this preparing food for the dead that afterwards is eaten by the living, as it indicates that for the participants in this tradition, existence evolves on two different levels: one nature and the other supernatural. Everything that exists shares in both aspects: one essential, the other transitory. As the dead belong to the former, it is the essence of the food, which they digest, while the living benefit only from the material substance. These same customs suggest another conclusion: that of the idea of the dead as members of a group of which they never entirely cease to be a part.”³⁸

It is commonplace to see families each weekend after this holiday, in cemeteries practicing similar rituals, cleaning the grave sites, replacing dead flowers with fresh bouquets. The dead continue to take part in the everyday life of the Mexican. Lastly, the Mexican attitudes towards death and life are also expressed with humor as if to literally “laugh in the face of death”. “In the end death is to be seen with a touch of humor in order that the psychological burden it implies may be lessened. Not only a smile but outright laughter and mockery distinguish some of the most typical manifestations of Mexican folklore concerning death.”³⁹

37 Stannard, David E. *Death in America*. p.103-104

38 *Ibid.* p. 104

39 *Ibid.* p. 109



ADDRESSING THE CONTEMPORARY

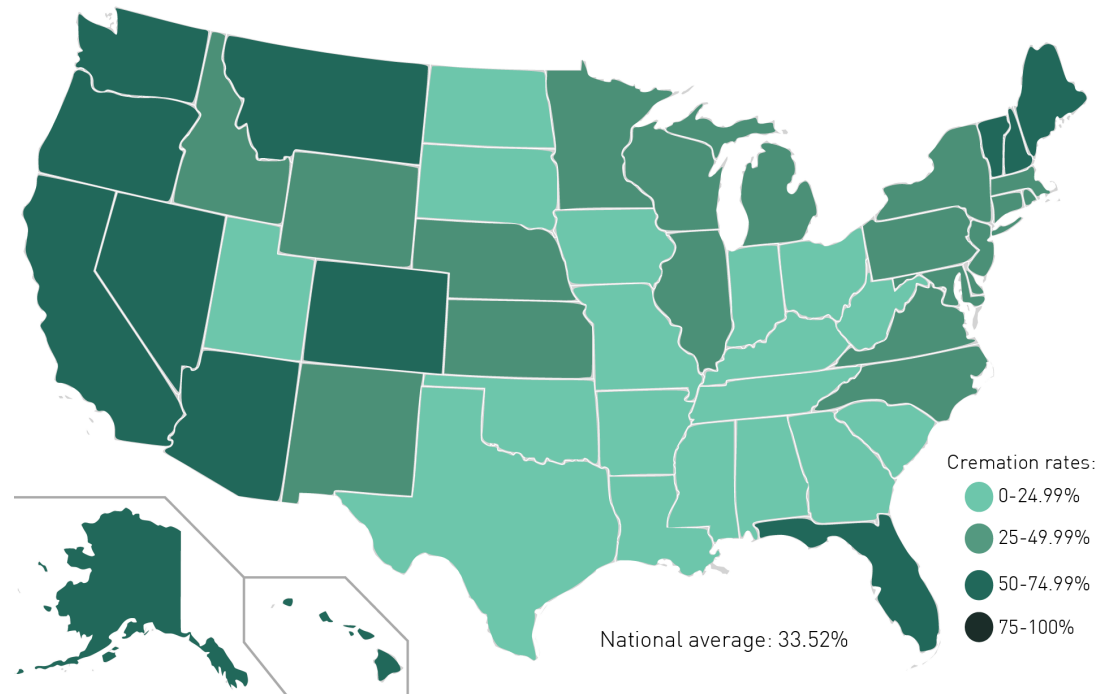

FIGURE 34 US Cremation Rates Map

Top 3 States in the US

- 1 Nevada 68.41%
- 2 Washington 67.57%
- 3 Hawaii 65.60%

Other Countries (2008)

- Japan - 99.85%
- Denmark - 76%
- Sweden - 70%
- UK - 72.44%
- Canada - 68.4%

Seattle's Cremation Rate (2012) =

65%

TRENDS IN CREMATION

More and more, people are opting for cremation than traditional burial. "According to the National Vital Statistics Department, 34% of deaths in the United States resulted in cremation in 2006. Based on current trends, the Cremation Association projects that number to grow to 40% by 2010 and almost 60% by 2025."⁴⁰ In Washington State, the trend towards cremation is significantly higher than the national average, ranking the second highest state of the percentage of cremations at 67%. There are a number of reasons of this upward trend in cremation; cost, lack of land space, environmental awareness, and personal preference. Cremation enables the ashes to be scattered or dispersed after cremation occurs, allowing greater personalization of funeral ritual making the process more desirable.

⁴⁰ Kavilanz, Parija B. *Funeral Cost-cutting Boosts Cremations*.



FIGURE 35 View of Crematorium at Vestfold



FIGURE 36 Vestfold Crematorium. View for visitors

However, the existing standard method of cremation in the United States is more fragmented than the disposition of burial, despite the nature of the process being more contemporary. Rituals attending cremation do not involve social contact with the most important parts of the ritual. The institutional process removes the family from the dead, leaving it in the hands of the crematorium that carries out the true ritual. The ashes are returned to the family for its final placement. A ritual well done should provide socially and personally meaningful connection between the living and the dead. One Norwegian crematorium completed in 2011, resolves this disconnection through its design. Designed by Pushak Architects, Vestfold Crematorium provides transparency and visibility throughout the entire ritual. The design choreographs the movement of the coffin that allows for engagement and visibility through the process, which can facilitate the mourning process.



FIGURE 37 Seattle Funeral Home



FIGURE 38 Seattle Funeral Home

THE STAGNANT FUNERAL HOME

The architecture of the funeral home attenuates social and personal relationships between the living and dead and so degrades even rich death rituals. It attempts to conceal death from its surrounding by adopting the banal appearance of the domestic home or storefront, while simultaneously enforcing the private and domestic nature of the space. The symbolic resemblance of a home within a modern space for death rituals attempts to reconcile the removal of death and dying from the family house “The identity of the contemporary funeral home is constructed from the remnants of the domestic and the sacred and struggles for independent architectural articulation. This is reflective of the cultural relationships with death that marginalize its presence.”⁴¹

“If places are indeed a fundamental aspect of man’s existence in the world, if they are sources of security and identity for individuals and for groups of people, then it is important that the means of experiencing, creating, and maintaining significant places are not lost.”⁴²

Hidden in the contemporary funeral home is the opportunity to change and enrich the current urban experience of mortality.

41 Laderman, *Rest in Peace*, p.26.

42 Relph, *Place and Placelessness*, p.6.

TRENDS IN SECULARIZATION

Secularization in the US has significantly increased in the past decade. A recent report by Pew Research Center’s Forum on Religion & Public Life illustrate the population of adults under 30 that have no religious affiliation is increasing. More people are atheist, agnostic, or unaffiliated with religion than ever before. (In fact, 46,000,000 Americans are religiously unaffiliated, by Pew’s count.)⁴³ A third of adults under 30 have no religious affiliation (32%), compared with just one tenth who are 65 and older (9%). In fact, “young adults today are much more likely to be unaffiliated than previous generations were at a similar stage in their lives”.⁴⁴

The city of Seattle ranks the third least religious city in the US, according to a poll from the Association of Statisticians of American Religious Bodies. Only 37% of the population in Seattle is affiliated with a particular religion or congregation. This illustrates that a growing number of the population will be searching for alternatives to both existing ritual and ceremonial spaces in dealing with death and dying.

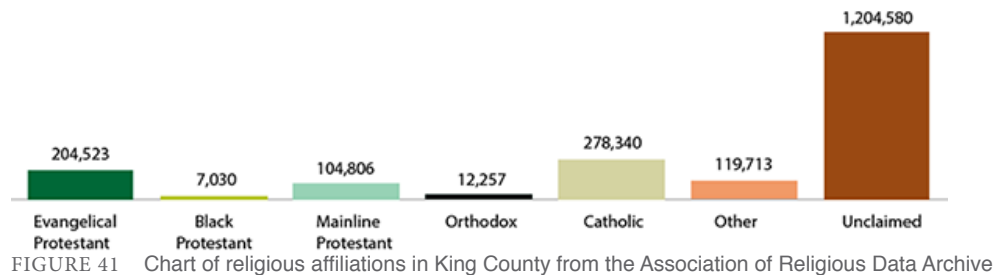

43 <http://www.pewforum.org/Unaffiliated/nones-on-the-rise.aspx>

44 <http://www.pewforum.org/Unaffiliated/nones-on-the-rise.aspx>

Growth of the Religiously Unaffiliated

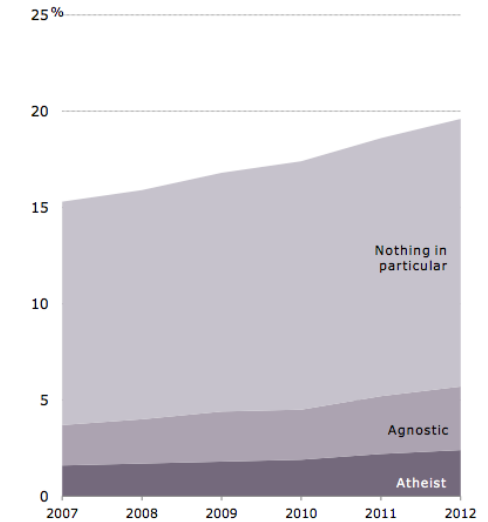

FIGURE 39 Pew Research Center Chart

Religious Affiliation by Age

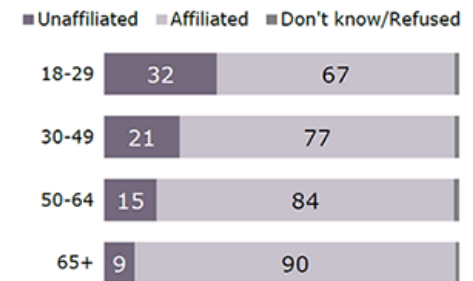

FIGURE 40 Pew Research Center Chart

ARCHITECTURE AND RITUAL

The following cemeteries were selected as precedents for their unique spatial qualities, design achievements and as exemplars of cemeteries with recreational uses not common in the US. Though the intent of this thesis is not to design a burial cemetery in the city, inquiry and analysis of these sites offer beneficial design references, particularly with program adjacencies, use of materials, and articulation of spaces.

WOODLAND CEMETERY, STOCKHOLM SWEDEN (ASPLUND AND LEWERENTZ)

“When the architects designed the landscaping and the buildings, they started with the experience of the visitors – the concept of mourning and the feelings surrounding it. Two processional routes leading to the chapels are designed to create the appropriate mood for mourners prior to the funeral service. After the service, attention is drawn to the natural surroundings, to help reconcile the mourners with the sadness of their loss as part of the circle of life.”⁴⁵ Seven Springs Way leading up to the Chapel of Resurrection cuts through the sublime forest. Walking through the path the forest appears increasingly dark as you approach the chapel. This is an example of the use of landscape evoking a particular emotion appropriate for the path. The Way of the Cross- leads into a monumental and sweeping landscape, which eventually leads to the crematorium. Though these two paths are slightly different, they both alter our perception of time and distance and enhance our experience of the forest. “No graves are visible at all until the visitor reaches the

⁴⁵ <http://www.skogskyrkogarden.se/en/architecture/Designed-experience.php>



FIGURE 42 Path to the Chapel of Resurrection



FIGURE 43 Way of the Cross

main chapel, and only then in the far distance, dotted among the columnar trees: e.g. there is just a vast rolling landscape, with deep forest beyond."⁴⁶ "The actual memorials are arranged a little way back from the paths that run through the cemetery so all you can really see to begin with is the avenue of trees which connect the chapels to the entrance."⁴⁷

The granite cross design by Asplund introduces the visitor towards the entrance. Their website states, "Since (the Woodland Cemetery) is a multi-ethnic cemetery serving faiths other than Protestant Christianity, the cross is not intended to represent a symbol of faith, but rather a symbol of the circle of life and death."⁴⁸ The intention of the design addressed the trend of the secularization of "extra-urban municipal cemeteries with an affirmation of the sacred value of the site itself."⁴⁹ The cemetery as whole was designed to address the changes of burial rituals and burial reform in Sweden.



FIGURE 44 Granite Cross

46 http://www.opendemocracy.net/ecology-landscape/article_840.jsp

47 <http://www.thelocal.se/8281/20070824/>

48 <http://www.skogskyrkogarden.se/en/architecture/granite-cross.php>

49 Constant, Caroline. *The Woodland Cemetery: Toward a Spiritual Landscape : Erik Gunnar Asplund and Sigurd Lewerentz, 1915-61.* p.5

IGUALADA CEMETERY, IGUALADA, SPAIN - (ENRIC MIRALLES, CARMEN PINOS)



FIGURE 45 Igualada Cemetery path



FIGURE 46 Igualada Cemetery

The Igualada Cemetery is a project that deeply roots the architecture with the landscape and enhances the concept for the site through the use of weathering materials to emphasize the impermanence of things.. The cemetery is comprised primarily of columbarium, crypts, and a funerary chapel. These buildings reflect the contours of the site, but their jagged, fragmented forms create a harsh route carved into the landscape.

From the surrounding landscape, the cemetery remains largely unseen and forces one to descend further into the cemetery in order to commune with the dead. This recalls the image and sensation of descending below the earth to the underworld. The circulation through the cemetery adheres to a more processional effect that focuses less on the organization of the burial plots, but rather on the experience. Darkness in spaces is used to evoke an emotional response and to create an atmosphere that is conducive to inward reflection and attention.

“With time and weather inevitably intervening in the work, covering and eroding it, allowing it to become part of the natural landscape, the Igualada Cemetery will eventually be perceived less as a burial ground, and will come to be seen more as a field, an area in which all the natural cycles of life and, alongside it, death, take place.”⁵⁰

The trees and landscaping of the site are meant to remain essentially unfinished, growing and eventually visually obscuring the presence of the cemetery while alluding to life dominating over death. The

⁵⁰ Zabalbeascoa, Anatxu. . *Igualada Cemetery: Enric Miralles and Carme Pinós* p. 86

weathering materials and their eventual patina contribute to the effect. The temporality of the site and project itself becomes in a sense becomes an organic architecture not immune to the process of life, death and rebirth.

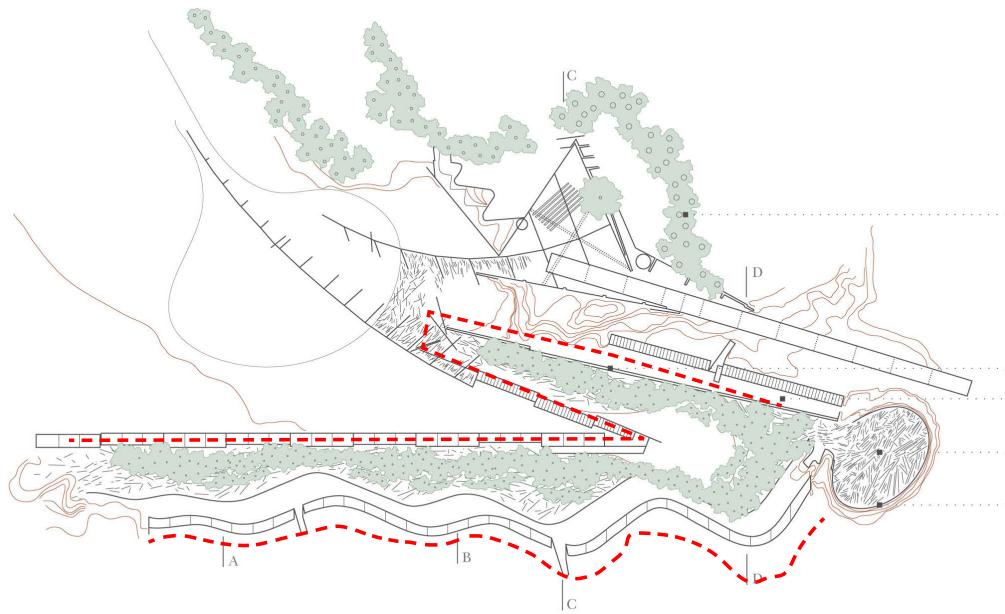
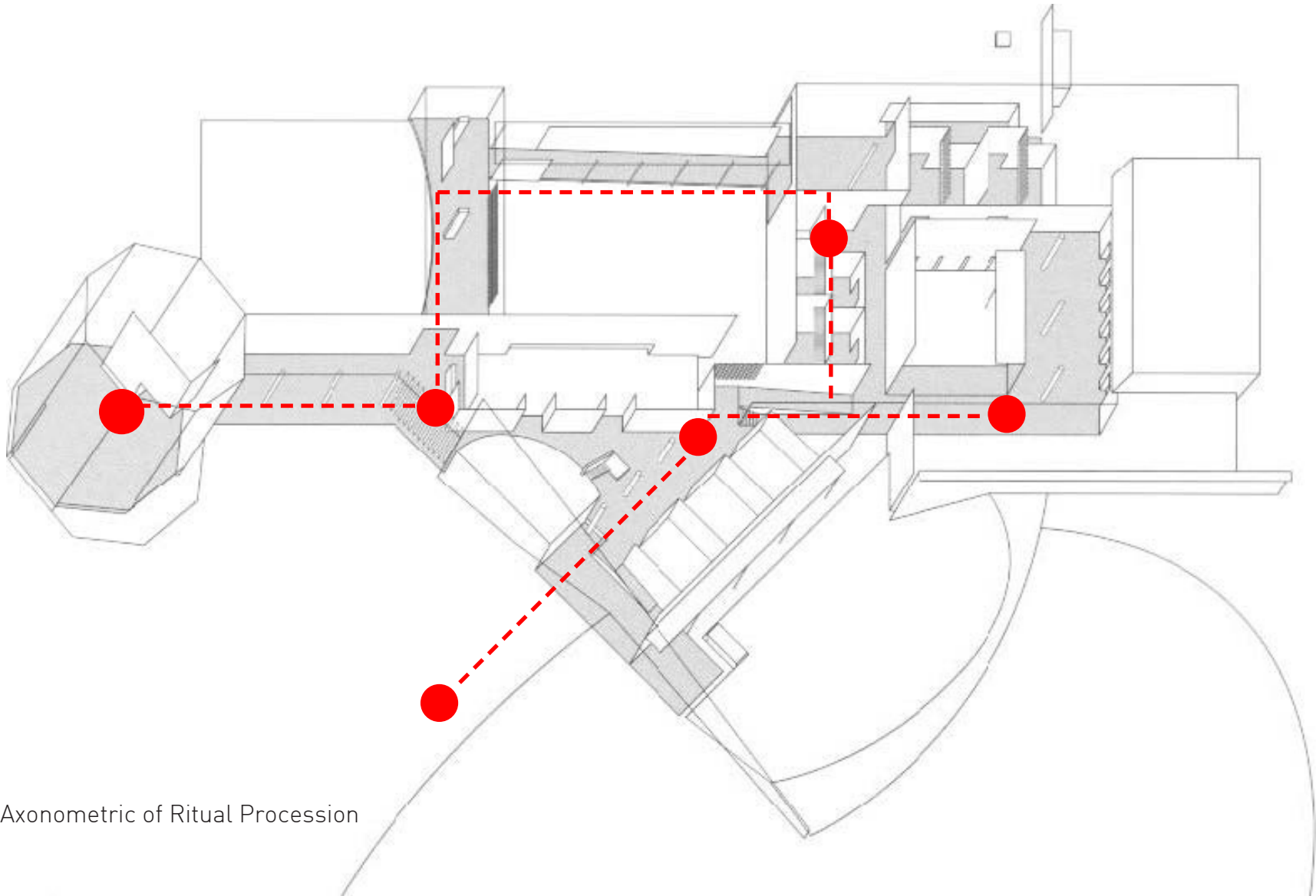

FIGURE 47 Igualada Cemetery - Site Map with circulation flanked by columbarium wall



Axonometric of Ritual Procession

FIGURE 48 Axonometric of Kaze No Oka. Diagram of pause and procession. Each pause is a separation of the program spaces.

KAZE-NO-OKA, NAKATSU OITA, JAPAN (MAKI AND ASSOCIATES)

Located in small town in Nakatsu, Japan, the Kaze-no-Oka crematorium spreads throughout the landscape with programmatic volumes connected by a defined processional path. The program areas consist of a funeral hall, crematorium and waiting area. The architect uses the processional path to as narrative for the experience. Careful consideration was given to the materials and light qualities in order to articulate the experiences of reflection and peacefulness.

As visitors progress through the buildings, the volumes sink into the ground and become more enclosed making the sources of light become increasingly diffused. There are no conventional windows on the monolithic volume. Edwin Heathcote in *Monument Builders* writes,

“The buildings themselves generally have no windows to afford views of the outside world. This not only reinforces the powerful effect of the internal geometries and the perception of the buildings as abstract sculpture in a landscape of death but also creates an internal language and referential system.”

51

This balance of choreographing programmatic spaces and site presence has encouraged the local community to use the surrounding cemetery for leisure activities as well as burial or memorial.⁵²

51 Heathcote, Edwin. *Monument Builders: Modern Architecture and Death*.p.153

52 Maki, Fumihiko. “*Fumihiko Maki: making of the public realm--from three recent projects*”



FIGURE 49 Kaze no Oka - Exterior View



FIGURE 50 View of the Reflection Pool

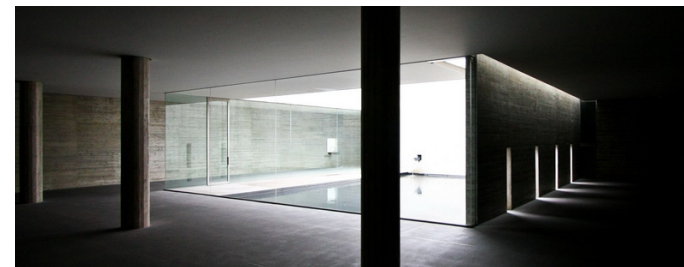

FIGURE 51 View of pool zoomed out.



FIGURE 52 Bike path through the cemetery

ASSISTENS KIRKEGÅRD, COPENHAGEN, DENMARK

Located in the Nørrebro district of Copenhagen, the cemetery, built in 1760 was originally a burial site for the poor outside the city walls. The name Assistens originally was a generic Danish name given to cemeteries laid out to 'assist' existing and older cemeteries in the city. The burial is home to a large number of Danish notables, such as Hans Christian Andersen and Søren Kierkegaard, but also exists as an important green space for the neighborhood. The local residents use the cemetery as a recreational park, spending time reading or picnicking on the grass, biking through the site, or performing plays and dance performances in the chapel.



FIGURE 53 Danish family picnicking in the cemetery

The cemetery today still serves as an active burial site but also has become an active tourist attraction with Andersen's grave being the most visited. The cemetery is divided in plan by a central path with entrances on both ends that has become a popular biking path and central access to the adjoining paths through the cemetery. The success of the plan and layout of the gravesites allows visitors to visit particular gravesites with ease of navigation and accessibility while providing intimate private spaces for grave visitation and recreational use.

SITE | SEATTLE, WA

HISTORY OF SEATTLE CEMETERIES



1st burial on 2nd & Columbia

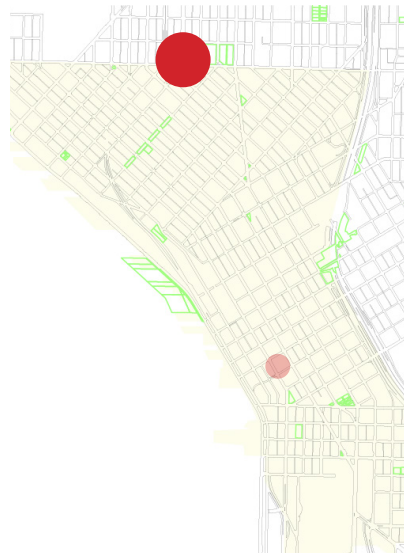

1861, 1st official city cemetery - Seattle Cemetery

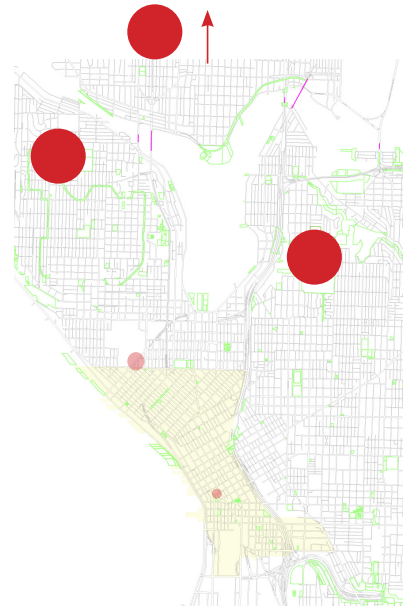

1880's, cemeteries moved further out

The history of Seattle cemeteries parallels the history of those in most American cities. Economically, the cemetery does not constitute the best use of land in the city, so as Seattle developed and expanded the city's cemeteries were removed and replaced for new development. Seattle's first burials grounds, primarily used by Native Americans and used both cremation and ground burial, is located at what is now Second and

Columbia. This site later became the site of the first Methodist Protestant or 'White Church' and the town's first formal graveyard.⁵³ The first city cemetery developed by David Denny who donated the land initially to become the first park in Seattle became a cemetery due to the demand. Located on what are now Denny Ave and the Seattle Center, the Seattle Cemetery, started in 1861, was used for over 20 years.⁵⁴ Several smaller cemeteries associated with other ethnic and fraternal groups opened around the city to address growing demand. These included the Masonic Cemetery and Odd Fellows cemetery located on what is now Queen Anne. Later renamed "Mt. Pleasant", the adjacent land housed Seattle's first crematory and columbarium which later became Arthur-Wright Funeral home. In the early 1880's, the city's expansion forced the removal of the largest cemetery, the Seattle Cemetery, and transformed it into Seattle Park. The bodies from Seattle were dispersed among the existing cemeteries in the area, one of which was the new Municipal cemetery, which is now Volunteer Park. Around the same period, David Denny started Oak Lake Cemetery on his private land located north of what is now Green Lake. When formed, Oak Lake was a far distance from the city center. Oak Lake Cemetery is now known as the Evergreen-Washelli Cemetery in its original location.⁵⁵ "Calvary Cemetery, situated on the northeast of the University of Washington, was the first major Catholic cemetery in Seattle and received its first burials in 1889."⁵⁶ As demand for land in the city's core, cemeteries were pushed out of the center of city life out to the suburban landscape, removing its visibility and relevance.





53 Daly, Laura C. *A History of the Cemeteries in the City of Seattle; and a History of Evergreen-Washelli Cemeteries.* p.4

54 Ibid, p. 5

55 Ibid, p.17

56 Ibid. p.18

Death in Seattle - Existing Cemeteries and Funeral Homes

-  Downtown urban core
-  Paved roads
-  City parks
-  Cemetery
-  Funeral Homes

Cemeteries and Funeral Homes in relation to Seattle's city core

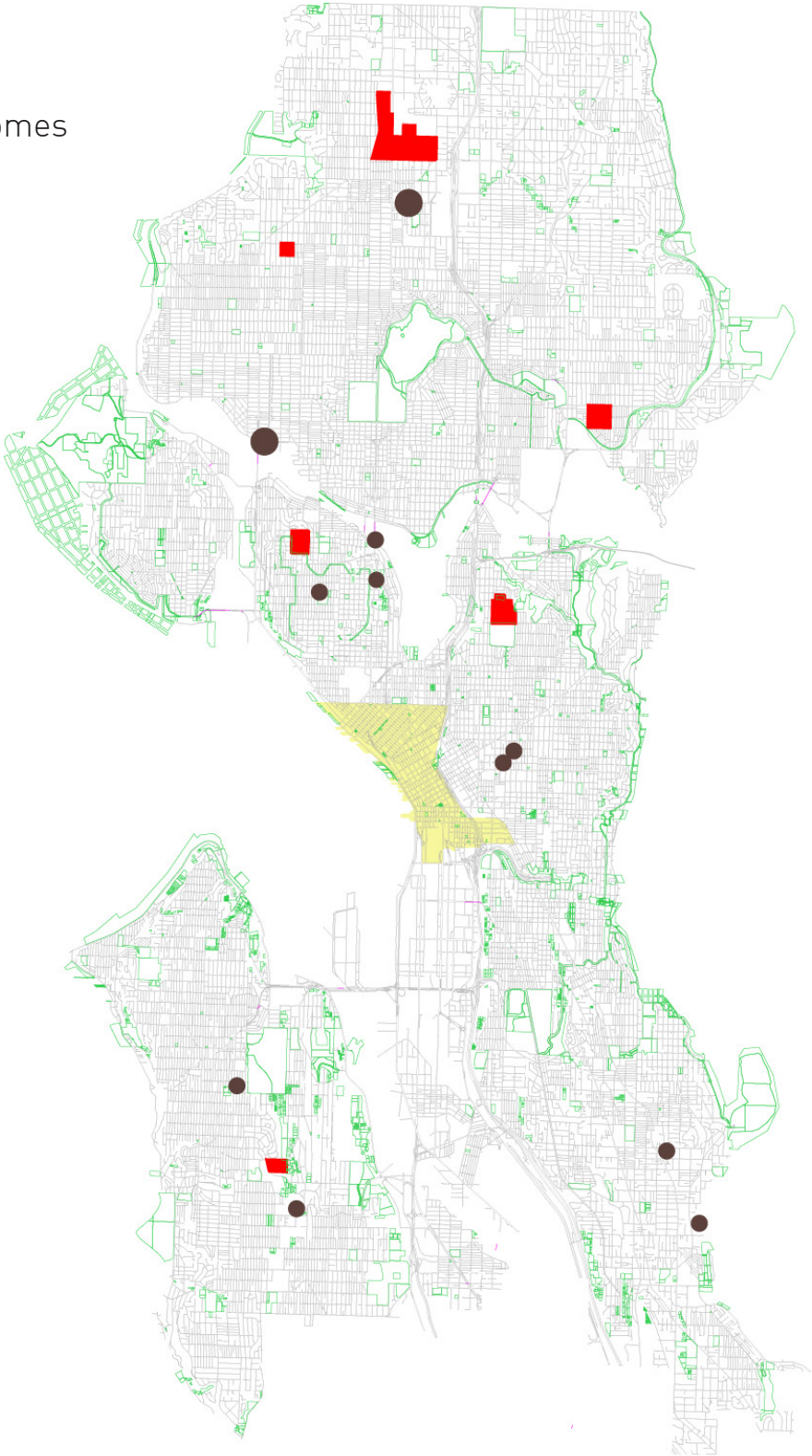

SITE SELECTION

Currently, Seattle has a healthy network of park and recreational spaces throughout the city. In the design and consideration of public space in the city, recreational activities are given priority as an amenity to the community it serves. There is opportunity to rethink the range of possibilities and functions that public space in Seattle can provide.

The major criteria for the site selection for this project are a central and prominent location in the city's central core and relevant adjacencies that can supplement the programmatic intentions. The site must allow for spaces that can host a range of daily activities and events to satisfy the criteria of participating in everyday urban life. Historical references, identity of the neighborhood, foot traffic, sun exposure, and size all contribute to the selection of the site. Many sites were examined and considered for the project, which illustrates the project's adaptability within an urban context. The site chosen, located in the Seattle neighborhood of Belltown, is currently a parking structure adjacent to the Olympic Sculpture Park by Weiss/Manfredi. The site sits on the Northwest corner by the park. When viewing the site on a map, it appears to carve out a corner of the Olympic Sculpture Park boundaries, which almost form a perfect rectangle. In many ways, a design opportunity arises to make the site and project an extension of the Park completing the rectangle. Bookended by two streets, Western Ave and Elliot Ave, the site provides unique design opportunities due to the grade change of thirty-two feet. It is an urban site with close proximity to downtown and views to the water. The proximity to the waterfront brings sufficient foot traffic to the area.



East Montlake Park



Grand Army of the Republic Cemetery



Lake View Cemetery and Volunteer Park

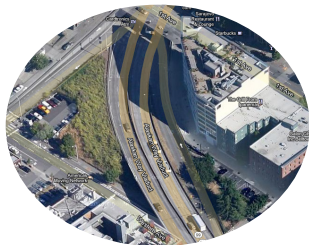

Battery St. Tunnel



Belltown Cottage



Kobe Terrace Park



Herring's House Park

POTENTIAL SITES



SITE HISTORY

The Denny Regrade is the site's most known event and involved the removal of Denny Hill flattening the area. The project, which began at the beginning of the Twentieth Century and completed 1991, was an attempt to transform Seattle as a new metropolis. "Denny Hill, which once covered 62 city blocks, was whittled away by continuous blasts of water. Twenty million gallons of water a day were pumped from Lake Union to the top of the hill with force enough to move 2,500-pound boulders."⁵⁷ Existing structures were slowly removed as the hill was flattened to transform the area.

The Olympic Sculpture Park was once a brown field, a polluted industrial site owned by Unocal for storing fuel. The restoration of the site involved soil remediation and restoring the bluff by importing over 200,000 cubic yards of fill. "The massive fill operation will restore natural topography while respecting existing infrastructure. A continuous plane of ground will be created from Western Avenue to the seawall, restoring lost views to humans and wildlife."⁵⁸ The site's history tells two stories of the cyclical nature of destruction, death, rebirth and renewal.

57 <http://www.djc.com/special/century/10060862.htm>

58 <http://www.djc.com/news/en/11146940.html>



FIGURE 55 Denny Regrade Remnants of Denny Hill.



FIGURE 56 Unocal Brownfield, what is now the Olympic Sculpture Park



FIGURE 57 View of Belltown today where Denny Hill once stood

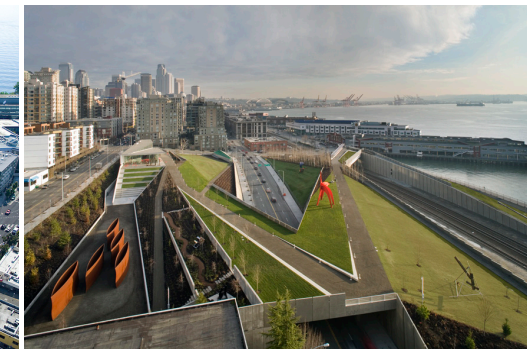

FIGURE 58 Olympic Sculpture Park



FIGURE 61 Photos of site's existing parking structure

DESIGN

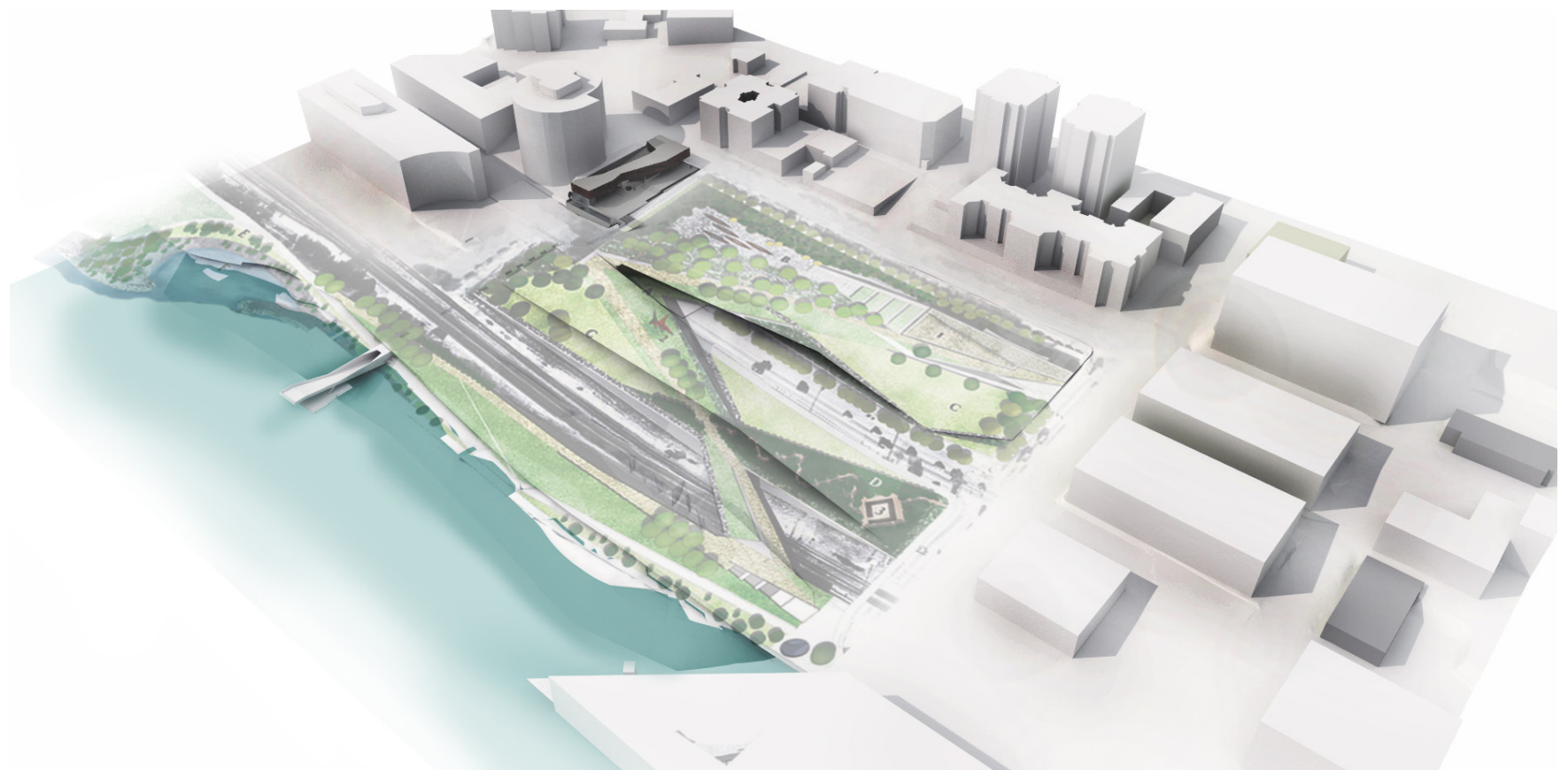

FIGURE 62 Rendering of site with new design

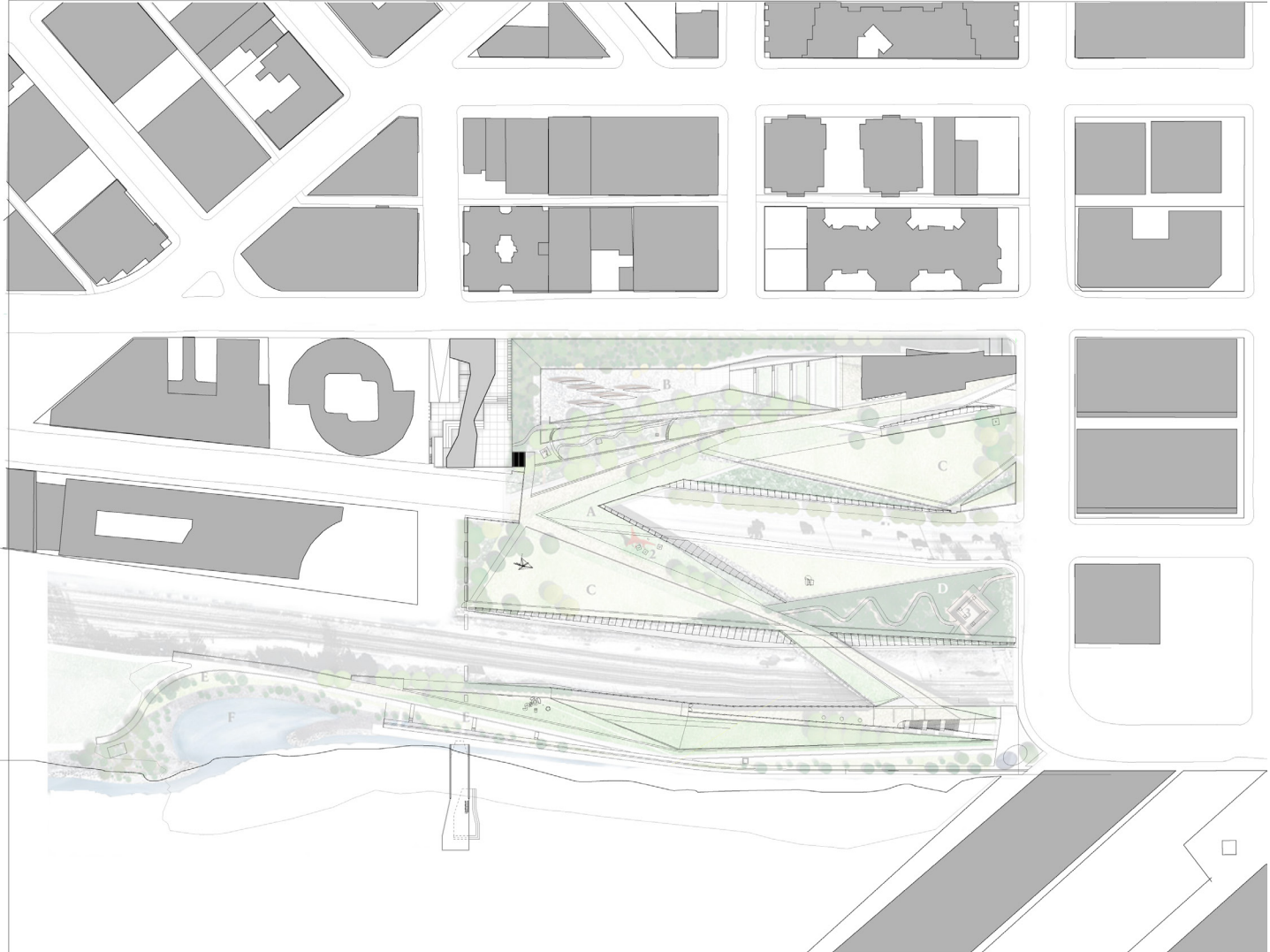

FIGURE 63 site plan



FIGURE 64 Rendering of design as viewed from the Olympic sculpture park standing facing the wake. To the left of the wake lies in entrance to the Columbarium Tunnel where mourners can access the park and the public can access the tunnel and pier.

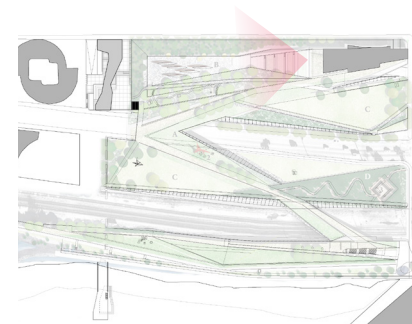
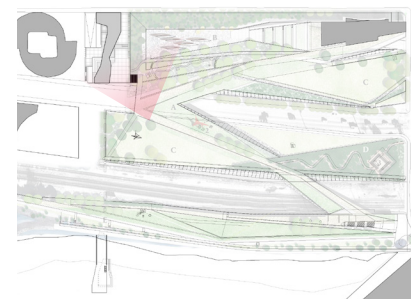



FIGURE 65 Rendering of the Memorial Site as viewed from the bridge over Elliot Ave.



THE PROGRAM

The programmatic approach for the site relied heavily on the consideration of different site visitors: the general public visiting the site, the mourners coming to the site for a ceremony, and the returning visitor for a memorial. The ground level at Western Ave is completely open to the public with entrances to the programmed spaces but designed as a public plaza with hard scape as seating for gatherings areas and connections to the Olympic Sculpture Park.

THE DIGITAL MEDIA LIBRARY

The cemetery as viewed as an archive of the city and culture becomes the medium in which the stories are told. With radio and Internet resources, storytelling has extended to a digital form. Popular programs aired on the radio and later podcasts such as *This American Life*, *StoryCorps*, and *The Moth* illustrate an inherent interest in listening to the stories of the lives of others. Located above the public courtyard, The Digital Media provides a public memorial space where visitors can hear stories of those that have passed and record their own, creating a digital archive of the lives of those who live in or visit Seattle. This digital archive will sustain the cemetery as a powerful link between generations and a guardian of cultural expression and meaningful rituals. The archive attempts to reinforce the role of storytelling as ritual and memorial to strengthen the connection to our past in order to better understand our future, creating a digital memento mori on the site.



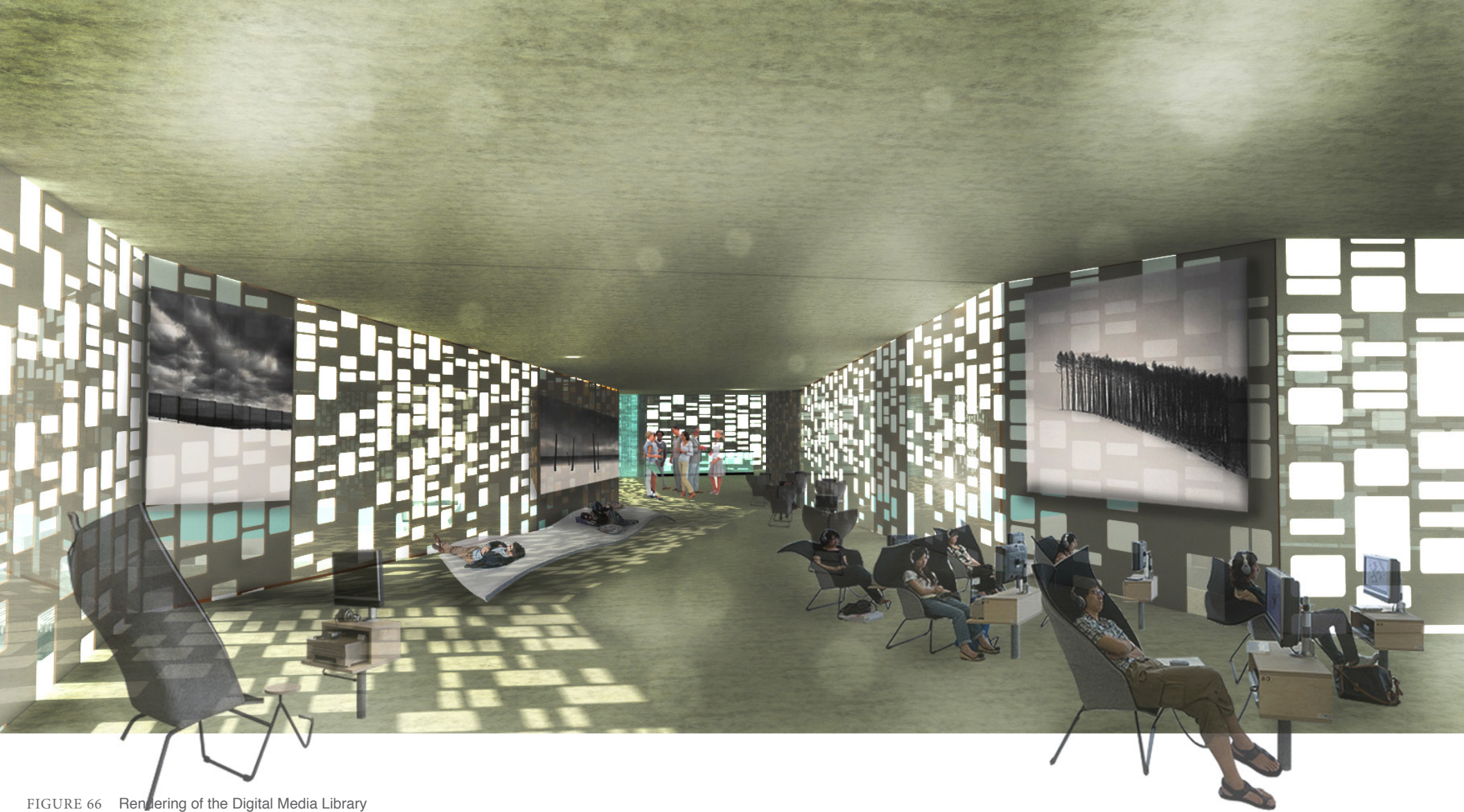
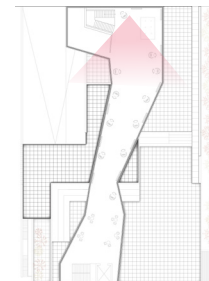

FIGURE 66 Rendering of the Digital Media Library



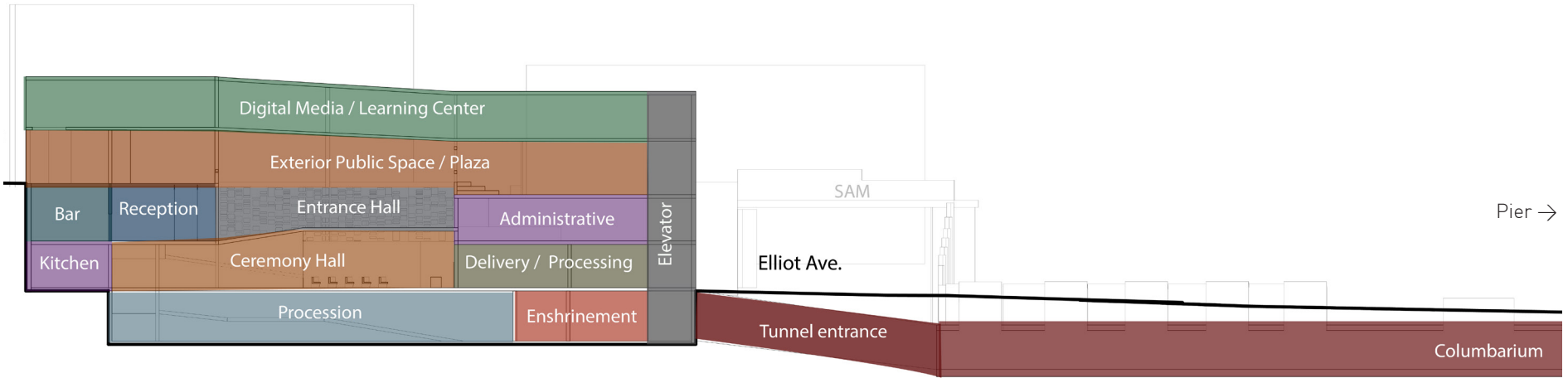

FIGURE 67 Program Diagram

6 User Groups

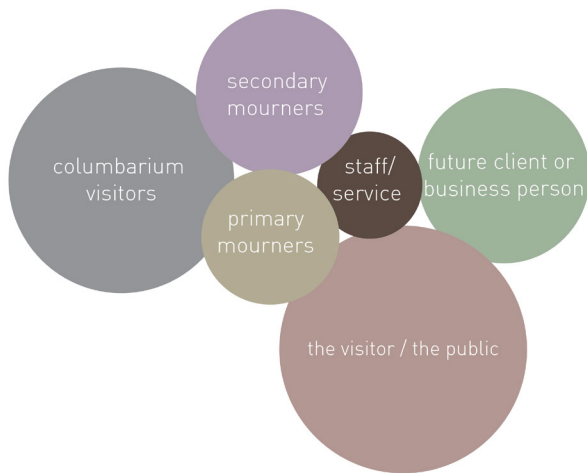

FIGURE 68 User groups organized in relation to their interaction

The program was organized to accommodate the different user groups with respect to the ceremony and to the everyday visitor. The path of procession then becomes the central focus with the supporting program bordering the site. The procession wide and open becomes increasingly compressed as you descend down the site to the end of the procession in the enshrinement room.

DESIGN METHODOLOGY

The design methodology utilizes the research of spatial qualities of the precedents and cultural typology discussed earlier. Exploration and analysis of precedents were used as tools for design, e.g. understanding rhythm and the transition from sacred spaces to public spaces. The site's conditions provided unique opportunities due to the grade change to have varying conditions in which the less public aspect of the program could be buried under ground level and the more public spaces to utilize the Olympic Sculpture Park to connect to the pier and to create an extension of the park. The close proximity to the water called for a connection to it. The connection to the water could have formed as either a bridge or tunnel to avoid the existing train tracks. The tunnel deemed a much appropriate design approach given the nature of the program. The concept of spatial layering and borrowed scenery provided a framework from which the design was developed.

MATERIALS

The chosen materials for the project reflect the notion of the impermanence of things. CorTen steel, wood and stone slabs were selected for their patina qualities. With age these materials change in color and nature to further emphasis the passing of time and impermanence. As the building ages the character of the building will change. These materials also provide a sensory quality to the programmatic spaces in which they were placed.

THE CEREMONIAL SPACES

The ceremonial spaces are connected through a series of processional ramps. As you descend through the building and ceremonial spaces, the processional ramps that begin as wide spaces compress in size towards the end of the procession separating the program areas in order to prepare the visitor for each step of the process. The focus is on the ritual; not dictating the process per se, but allowing for many interpretations of the process and fluidity through the building. The path starts on Western Ave and descends to the entrance hall, a recessed courtyard for gathering before entering into the building. This is the place for gathering and collecting oneself before entering. The mourners continue inside where reflection rooms are situated for moments needed for solitude and pause. A long and straight path connects the mourners with the staff and a waiting area where a large window opens out to Elliot Bay. From this view, the mourners can see the park, the bay and the pier connected to the building. The path continues down to a large ceremonial hall and the Resomation Room for the ritual and ceremony to take place. The Resomation Room provides visual access for the mourners to the final processing of the body. An atrium from the entrance hall to the ceremony space brings natural light down to ceremony hall and ramps and is populated with greenery for reflection and the contemplation of the impermanence of life. Waiting areas and a reflection bar are provided in the area until it is time to collect the ashes in the enshrinement room. The enshrinement room consists of a curved wall that opens towards the tunnel to provide a comforting sense of enclosure for the final step of the ceremony. The completion of the ceremony occurs with the placing of the ashes in their final resting place, the columbarium.



FIGURE 69 Rendering of Entrance Hall where mourners arrives and collect themselves before entering into the building

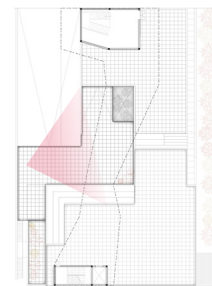



FIGURE 70 Ceremonial Path - As mourners wait for the ceremony, areas to reflect are provided. The window in the center of the rendering overlooks Elliot Bay with a view of the pier

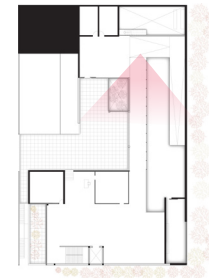



FIGURE 71 Rendering of the Ceremony Hall and view of the atrium space that brings light into the space

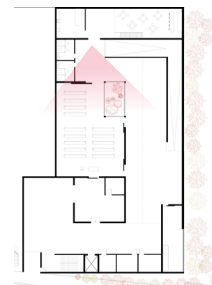



FIGURE 72 Rendering of the Reflection Room

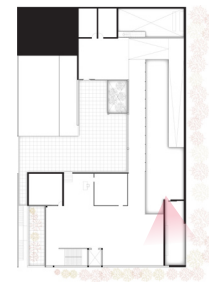
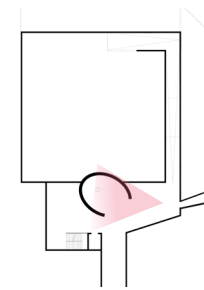



FIGURE 73 Rendering of the Reflection Room where the ashes are collected. The entrance to the columbarium tunnel is located to the left (not shown)



THE COLUMBARIUM, TUNNEL AND PIER

The memorial site only holds cremated remains in a columbarium. The columbarium is placed in a tunnel that opens up to a pier in Elliot Bay. The pier allows an alternative ritual of the spreading of ashes if that is preferred. The columbarium wall is used as retaining wall for the tunnel, which is day lighted by light wells. The public can access the tunnel by an entrance in the Olympic Sculpture Park. The entrance located adjacent to Richard Serra's sculpture titled "Wake", cuts through the existing topography of the Park and descends down into the tunnel level. The access can be closed off during a ceremony and open the remaining time. The columbarium, tunnel and pier then become a part of public space connecting visitors of the park to the pier. The pier, unlike the existing piers in Seattle, is designed for the pedestrian use only and houses no defined program. It is meant to be another public amenity.



FIGURE 74 Rendering of the Columbarium Tunnel. The Tunnel opens up to the pier

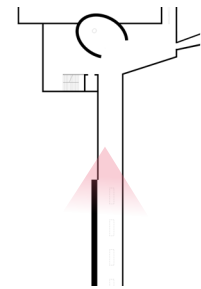
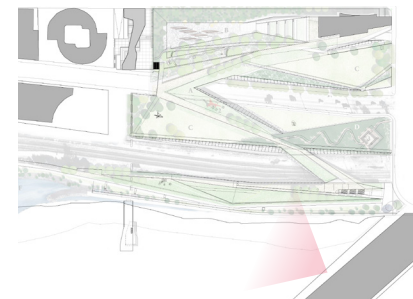



FIGURE 75 Rendering of Pier in relation to the building (to the right). View is taken from the adjacent existing pier (shown in the site map)



RESOMATION OR BIO-CREMATATION

The memorial site houses facilities to process the body as a part of the ritual. In lieu of traditional cremation which “according to the research of University of Melbourne professor Roger Short, create up to 350 lb. (160 kg) of greenhouse gases per corpse”⁵⁹, the process of Resomation, also known as Aquamation or Bio-Cremation was chosen. Instead of using fossil fuel to produce high temperatures to burn the body, Resomation uses an alkaline hydrolysis process reducing the body to ash. This method is increasingly being used in other countries and gaining attention in the United States. Compared to cremation, the process uses “less than one-seventh of the energy required for a cremation.”⁶⁰ Because the process also uses a steel chamber, the burning of a coffin also becomes unnecessary. This process has a much smaller carbon footprint than cremation and allows for a design not dictated by the required exhausts for a fossil fuel-based cremation.

59 Kamenev, Marina. “Aquamation: A Greener Alternative to Cremation?”.web.

60 www.resomation.com, n.d. Web.

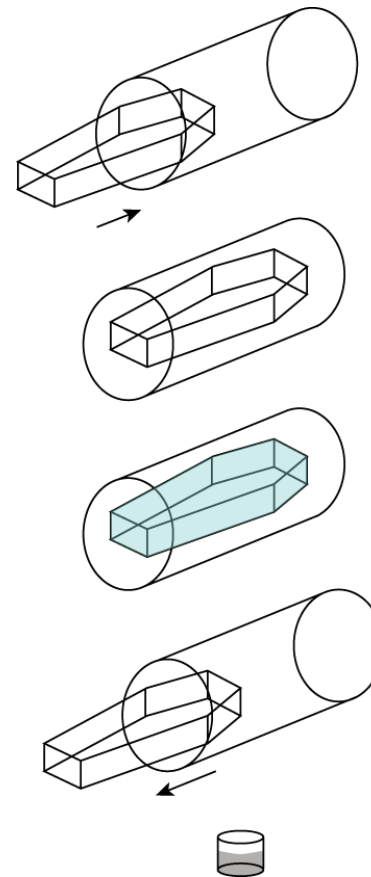

FIGURE 76 Resomation process

1. Resomation chamber prepared. Body placed in reusable steel coffin

2. Coffin placed in chamber

3. Water and Potassium hydroxide introduced to change and heated to 150 degree Celsius and pressurized.

Process yields two substances:

a) liquid that contains peptides and sugar, and amino acids

b) calcium phosphate or bio-ash

Ashes are returned to family and liquid reused for horticulture.

source: http://www.resomation.com/index_files/Page347.htm

DRAWINGS

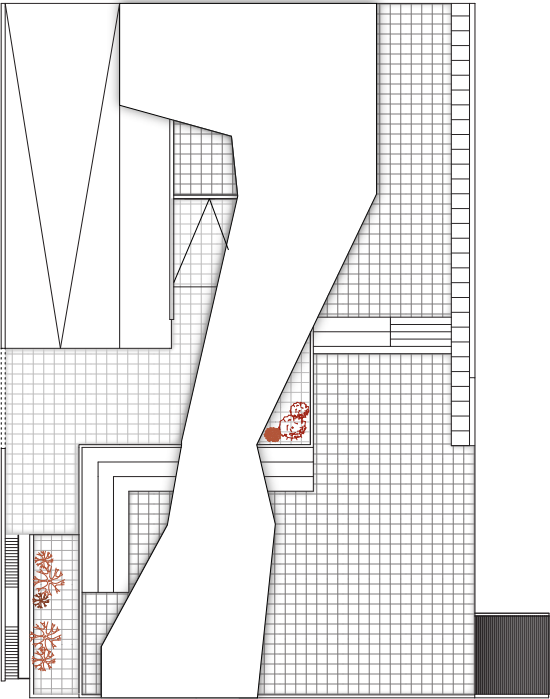

FIGURE 77 Roof Plan

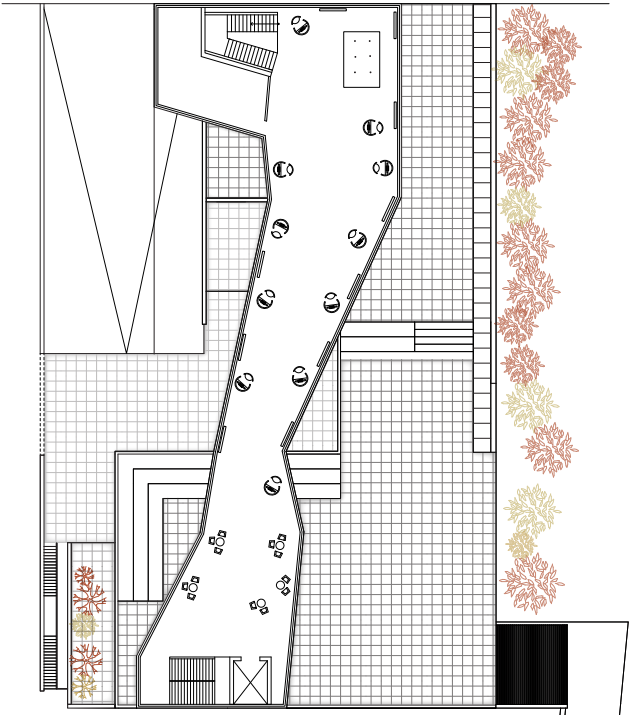

FIGURE 78 First floor above grade at Western Ave

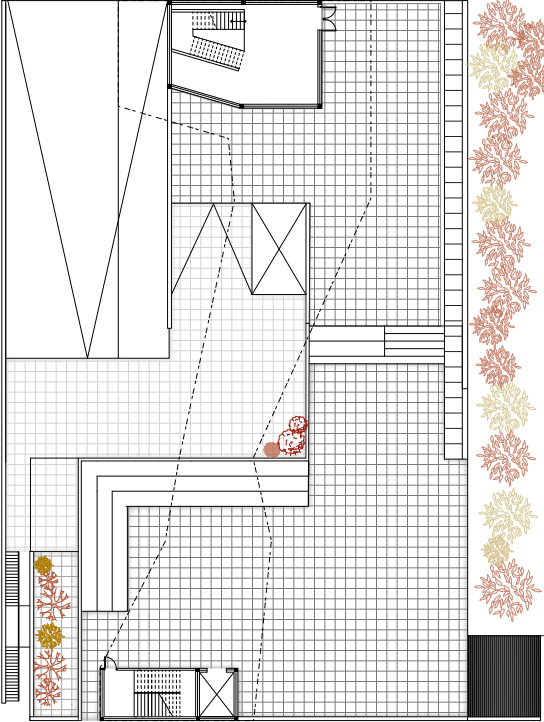

FIGURE 79 Ground plan at Western Ave.

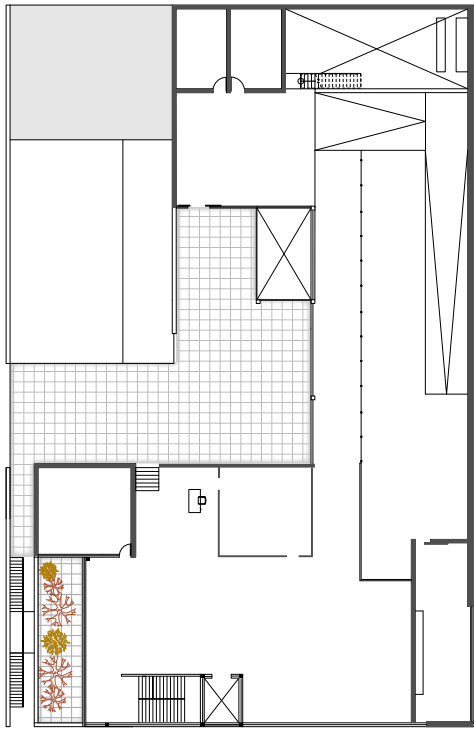

FIGURE 80 First floor plan below Western Ave

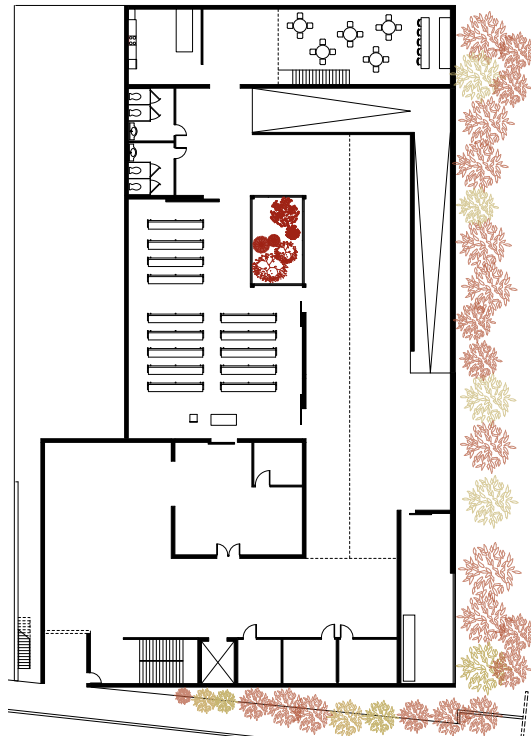

FIGURE 81 Ground plan at Elliot Ave.

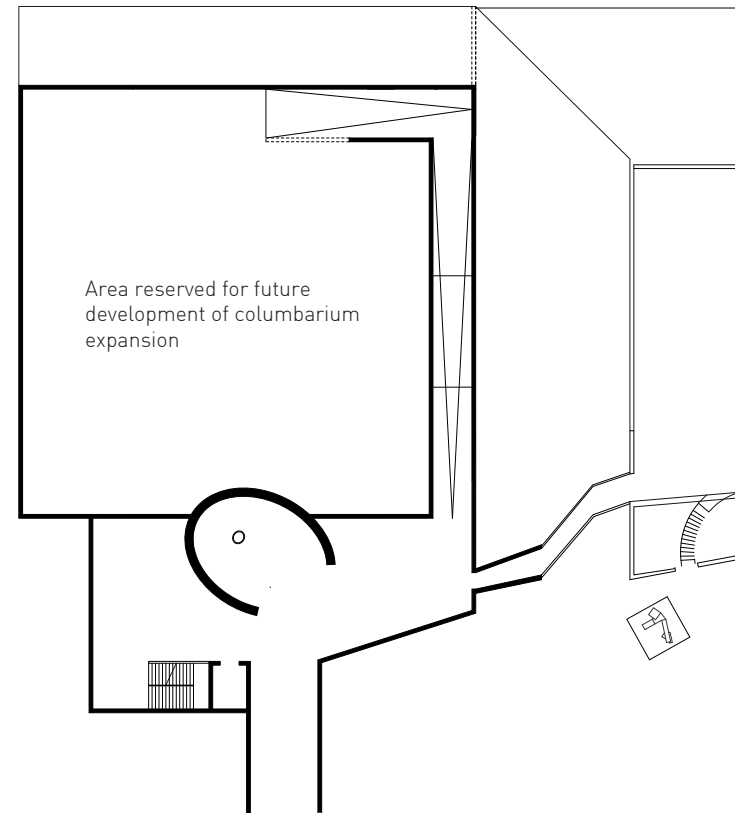

FIGURE 82 Plan at Tunnel level

SECTIONS

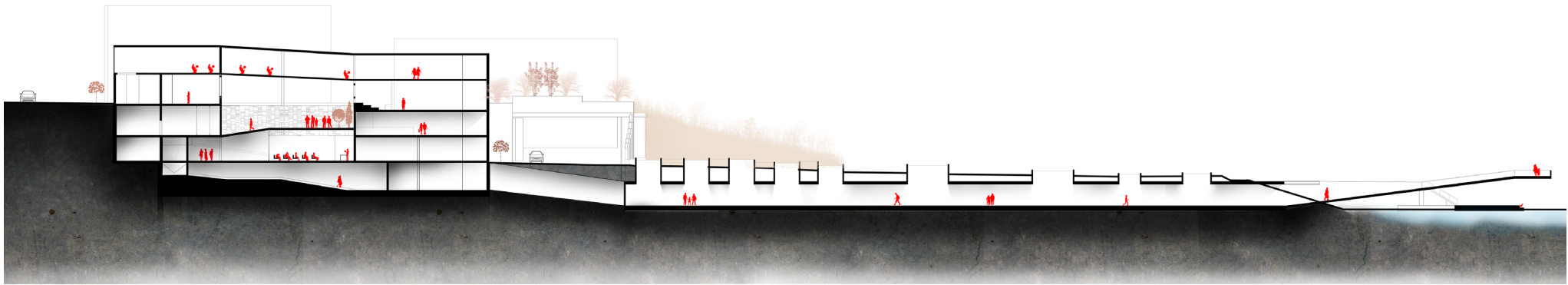

FIGURE 83 Longitudinal Section facing East

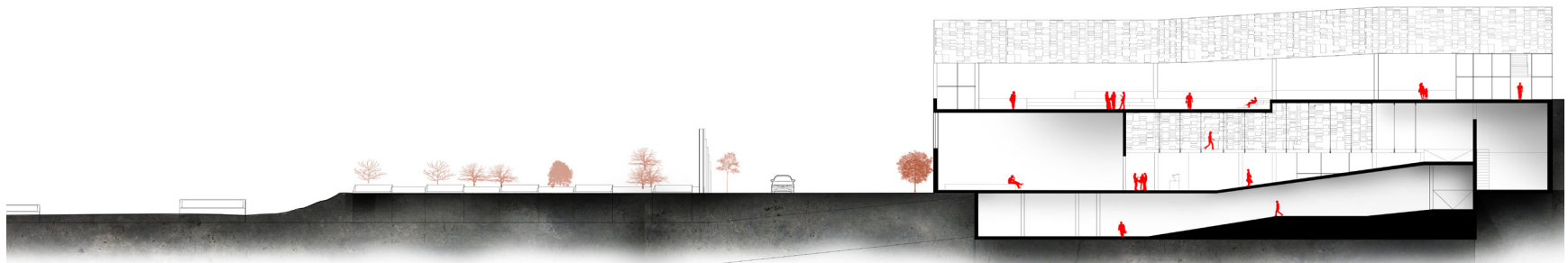

FIGURE 84 Longitudinal Section facing West

SITE CIRCULATION

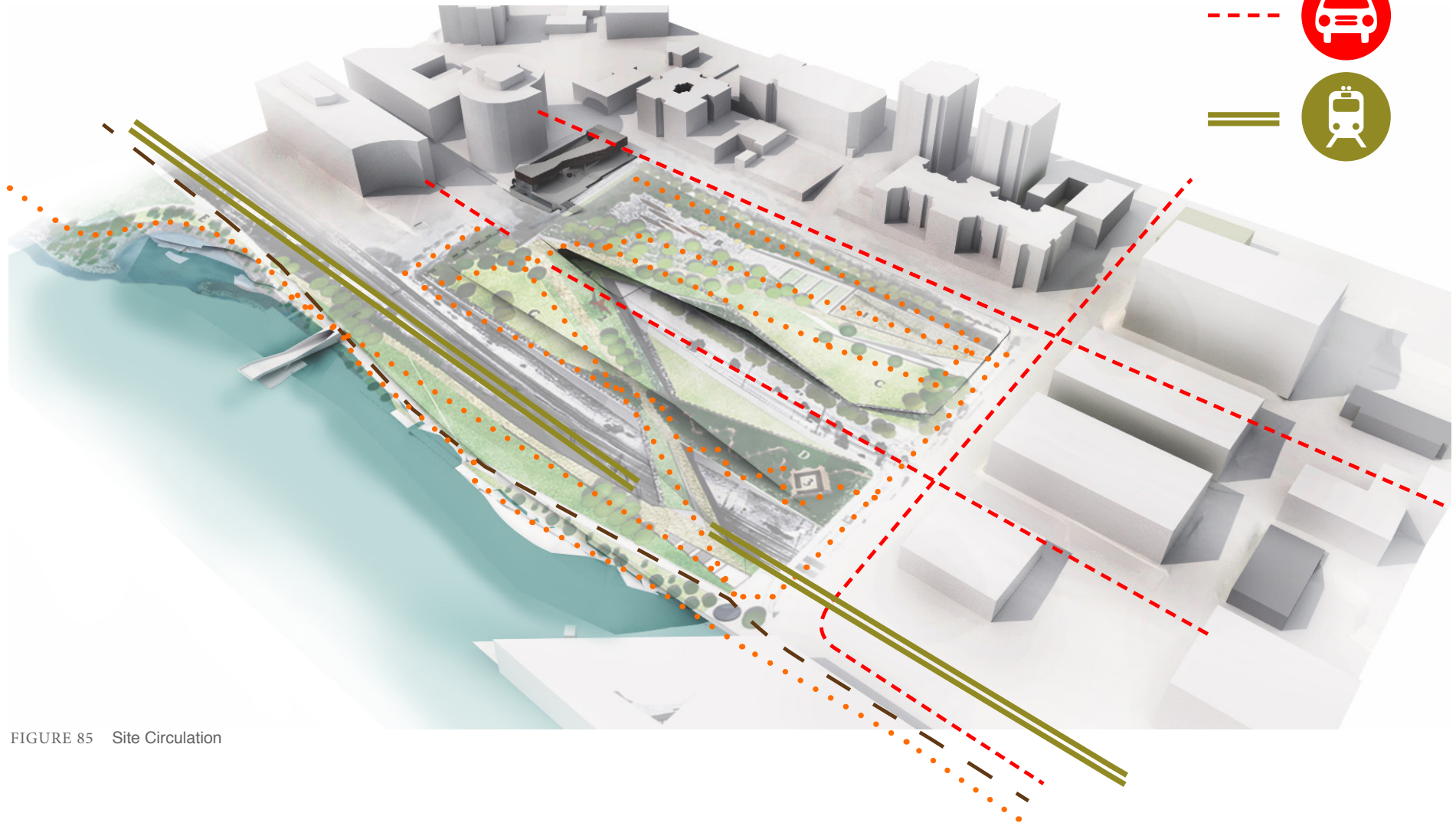

FIGURE 85 Site Circulation

MOURNER'S PROCESSION AND PUBLIC CIRCULATION

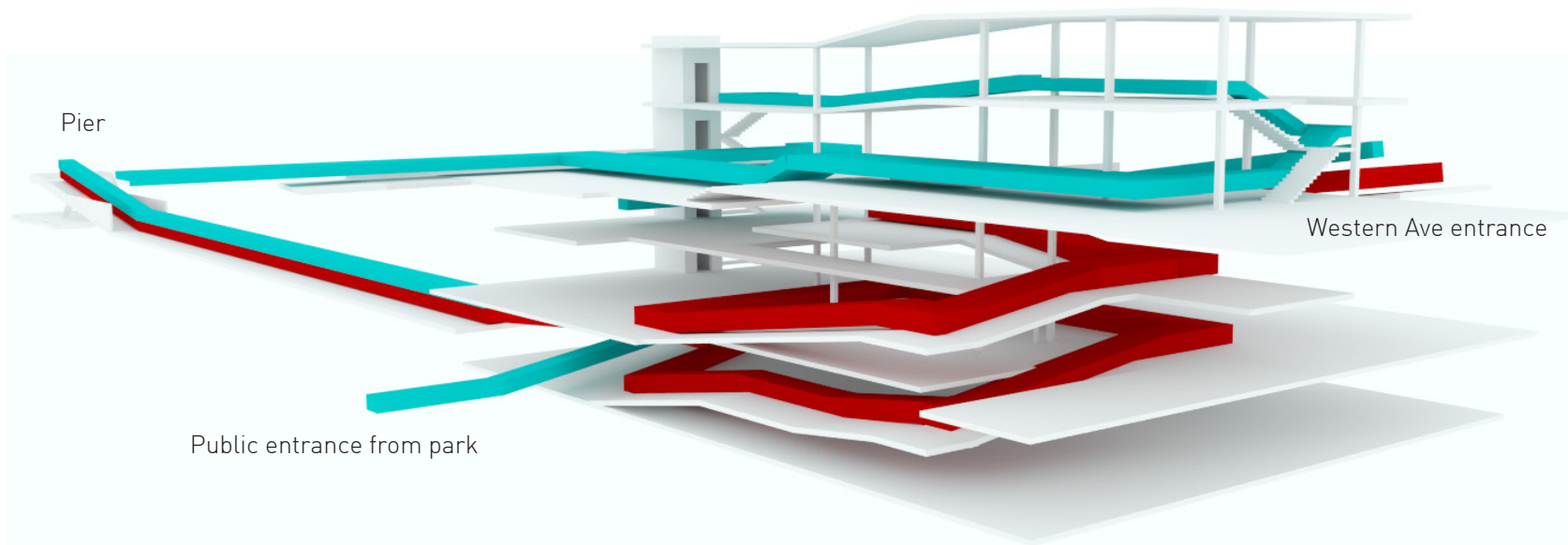
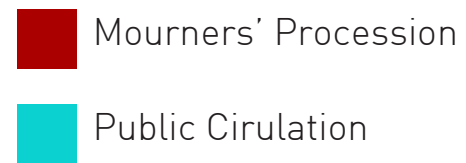

FIGURE 86 Circulation diagram



MODEL IMAGES



FIGURE 87 Photo of full model



FIGURE 88 Photo of building section with the model pulled apart to reveal the section

The intent for the model was to show the building sectionally, the columbarium tunnel and the light wells for daylighting. The tunnel pulls apart to reveal the columbarium wall in the tunnel. The tunnel was cut to show the light well quality leaving the pier unmodeled.

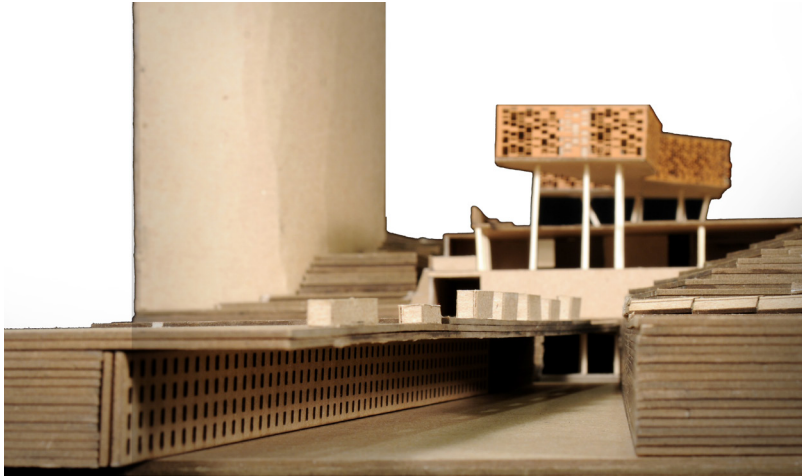

FIGURE 89 Photo of tunnel modeled pulled apart to reveal the columbarium wall

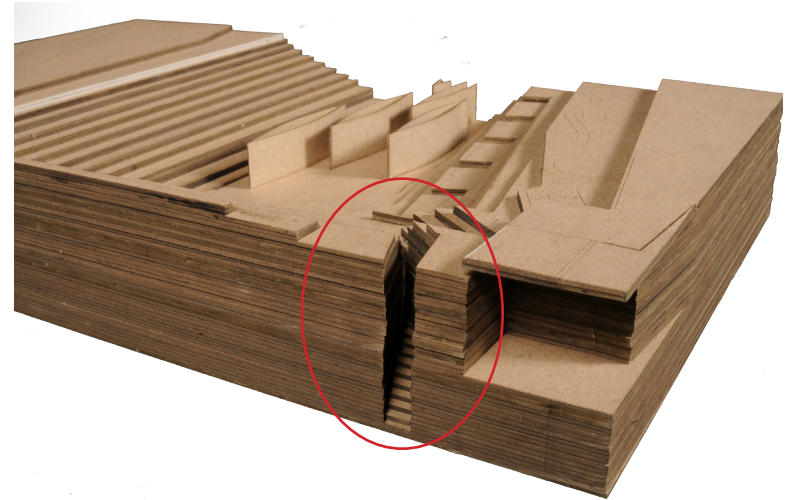

FIGURE 91 Photo of model pulled apart to reveal the path that connects the park to the tunnel for public access. View is taken from building to the park.



FIGURE 90 Photo of tunnel and light wells to reveal spatial quality

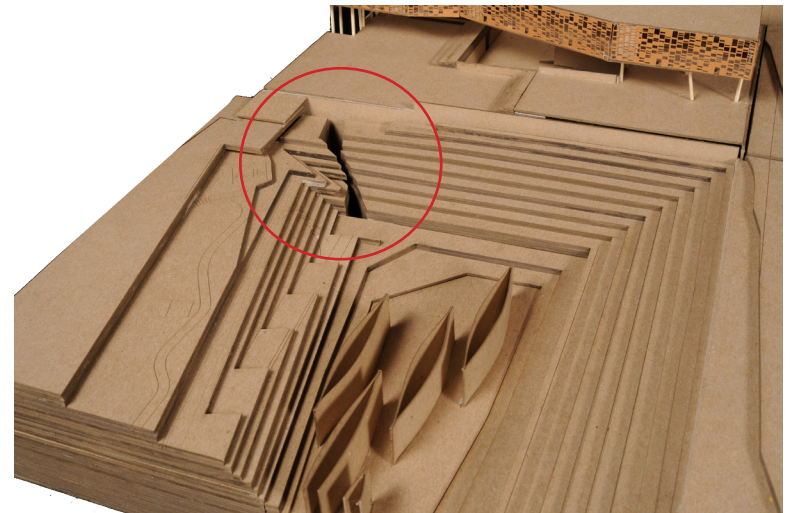

FIGURE 92 Photo of model from the park to the path towards the building and tunnel. From the wake visitors can enter the site to go to the tunnel

CONCLUSION

This thesis began with a critical examination of the rituals and attitudes surrounding death, the cemetery, and funerary architecture as a typology in the US. The thesis was formed from a culmination of my architectural education and experiences abroad. The exposure to new architecture, culture and art began the inquiry into how we, in the US, think about and ritualize death and dying. Further research on existing funerary architecture, practices and attitudes revealed a stagnant architectural response to the way we ritualize and memorialize the dead. Existing solutions have not evolved to address contemporary needs towards matters surrounding death and dying. Proposing a memorial site adjacent to the Olympic Sculpture Park, was an attempt to integrate death back to the city to serve as an architectural memento mori.

One of the challenges of this project and one that was discussed during the final review is the question of blurring the lines between what is public and what is private. In some ways, the project questions what should be inherently private and what should spill out into the public realm. The very nature of the thesis is questioning the role of death in the public realm. The goal of this project was to start the conversation and awareness of the dire options available and the need for better architectural solutions.

REFERENCES

Albrecht Fürst von Urach, *Das Geheimnis japanischer Kraft* (Berlin: Zentralverlag der NSDAP, 1943) English Translation Source: <http://www.calvin.edu/academic/cas/gpa/japan.htm>

Aries, Philippe. *Images of Man and Death*. Cambridge, Mass: Harvard University Press, 1985. Print.

Constant, Caroline. *The Woodland Cemetery: Toward a Spiritual Landscape : Erik Gunnar Asplund and Sigurd Lewerentz, 1915-61*. Stockholm: Byggförlaget, 1994. Print.

Curl, James S. *A Celebration of Death: An Introduction to Some of the Buildings, Monuments, and Settings of Funerary Architecture in the Western European Tradition*. New York: Scribner, 1980. Print.

Daly, Laura C. *A History of the Cemeteries in the City of Seattle; and a History of Evergreen-Washelli Cemeteries*. Seattle, Wash: Evergreen-Washelli Cemeteries and Funeral Home, 1984. Print.

"Deadly impressive: Stockholm's woodland cemetery - The Local." *thelocal.se*. N.p., n.d. Web. 25 June 2013 (<http://www.thelocal.se/8281/20070824/>)

"Denny Regrade: Hosing Seattle into shape". *Seattle Daily Journal of Commerce (djc.com)* N.p., n.d. Web. 25 June 2013 (<http://www.djc.com/special/century/10060862.htm>)

"Designed experience | Skogskyrkogården - Världsarvet ...". *skogskyrkogarden.se* N.p., n.d. Web. 25 June 2013 (<http://www.skogskyrkogarden.se/en/architecture/created-experience.php>) z. New York: W.W. Norton & Co. ;, 2010. Print.

Etlin, Richard A. *The Architecture of Death: The Transformation of the Cemetery in Eighteenth-Century Paris*. Cambridge, Mass: MIT Press, 1984. Print.

Farrell, James J. *Inventing the American Way of Death, 1830-1920*. Philadelphia: Temple University Press, 1980. Print.

"Funeral Industry — History of the Industry | Funeralwise." *funeralwise.com*. N.p., n.d. Web. 25 June 2013 (<http://www.funeralwise.com/learn/industry>)

Gangnes, Drew A. *Seattle DJC.com Local Business News and Data*. *www.dcj.com*, 17 July 2003. Web. 26 June 2013. (<http://www.djc.com/news/en/11146940.html>)

Grollman, Earl A. *Concerning Death: A Practical Guide for the Living*. Boston, Mass: Beacon Press, 1974. Print.

Heathcote, Edwin. *Monument Builders: Modern Architecture and Death*. Chichester, West Sussex: Academy Editions, 1999. Print.

Heidegger, Martin. *Being and Time*. New York: Harper, 1962. Print.

Jackson, Charles O. *Passing: The Vision of Death in America*. Westport, Conn: Greenwood Press, 1977. Print.

Kavilanz, Parija B. "Funeral Cost-cutting Boosts Cremations." CNNMoney. Cable News Network, 02 Apr. 2009. Web. 13 Apr. 2013.

Kamenev, Marina. "Aquamation: A Greener Alternative to Cremation?" *Time Magazine*. N.p., 28 Sept. 2010. Web. 18 June 2013.

Kawano, Satsuki. *Nature's Embrace: Japan's Aging Urbanites and New Death Rites*. Honolulu: University of Hawaii Press, 2010. Print.

Krasno, Rena, and Toru Sugita. *Floating Lanterns and Golden Shrines: Celebrating Japanese Festivals*. Berkeley, Calif: Pacific View Press, 2000. Print.

Laderman, Gary. *Rest in Peace a Cultural History of Death and the Funeral Home in Twentieth-Century America*, edited by MyiLibrary. New York ; Oxford: Oxford University Press, 2003. Print.

Mack, Arien. *Death in American Experience*. New York: Schocken Books, 1973. Print.

Maki, Fumihiko. "Fumihiko Maki: making of the public realm--from three recent projects "Istanbul: Borusan Kültür Ve Sanat, 1999. Print.

McKay, Brett and Ann. "Memento Mori: Art to Help You Meditate on Death and Become a Better Man." *The Art of Manliness* RSS. N.p., 29 Oct. 2012. Web. 25 June 2013.

Ohnuki-Tierney, Emiko. *Kamikaze, Cherry Blossoms, and Nationalisms: The Militarization of Aesthetics in Japanese History*. Chicago: University of Chicago Press, 2002. Print.

Paz, Octavio. *The Labyrinth of Solitude; the Other Mexico; Return to the Labyrinth of Solitude; Mexico and the United States; the Philanthropic Ogre*. New York: Grove Press, 1985. Print.

Polt, Richard F. H. *Heidegger: An Introduction*. Ithaca, N.Y: Cornell University Press, 1999. Print.

Ragon, Michel. *The Space of Death: A Study of Funerary Architecture, Decoration, and Urbanism*. Charlottesville: University Press of Virginia, 1983. Print.

Stannard, David E. *Death in America*. Philadelphia: University of Pennsylvania Press, 1975. Print.

Seligman, Adam B. *Ritual and Its Consequences: An Essay on the Limits of Sincerity*. Oxford: Oxford University Press, 2008. Print.

"Stockholm Woodland Cemetery | openDemocracy." *Opendemocracy.net*. N.p., n.d. Web. 25 June 2013 (http://www.opendemocracy.net/ecology-landscape/article_840.jsp).

Wilson, Colin S. J. *Architectural Reflections: Studies in the Philosophy and Practice of Architecture*. Oxford: Butterworth Architecture, 1992. Print.

Worpole, Ken. *The Cemetery in the City: A Report*. Stoud, Glos: Comedia, 1997. Print.
www.resomation.com, n.d. Web. June, 18th, 2013

Zabalbeascoa, Anaxu. *Igualada Cemetery: Enric Miralles and Carme Pinós*. London: Phaidon, 1996. Print.

Zuckerman, Phil. *Society Without God: What the Least Religious Nations Can Tell Us About Contentment*. New York: New York University Press, 2008. Print.

NOTE: All figures were taken either from the references already sourced, web resources or sourced by the author and solely used for academic purposes.