

Copyright 2011 Stephen Shatswell

The Tradition of Making:  
An Urban Craft and Cultural Center in Seattle's Pioneer Square

Stephen Shatswell

A thesis submitted in partial fulfillment of the requirements for the degree of

Master of Architecture

University of Washington  
2011

Brian McLaren, Co chair  
Gundula Proksch, Co Chair

Program Authorized to Offer Degree:  
Department of Architecture, College of Built Environments

(This page intentionally left blank)

To the Word, through whom all things were made.

And to my parents, who made me.

# Contents

<b>Prologue</b> .....	<b>8</b>
<b>Chapter 1</b>	
<b>Introduction:</b> .....	<b>9</b>
1.1_The Tradition of Making.....	9
<b>Chapter 2</b>	
<b>Theoretical Framework:</b> .....	<b>11</b>
2.1_The Inherent Value of the Maker as Craftsman.....	11
2.2_The Systemic Devaluing of Process.....	15
2.3_The Comprehensive Devaluing of Product.....	21
2.4_The Impaired Consumer’s Ignorance of Value.....	24
2.5_Theoretical Conclusions.....	25
<b>Chapter 3</b>	
<b>Precedent Analysis:</b> .....	<b>27</b>
3.1_Precedent Selection Rationale.....	27
3.2_Precedents.....	27
Facebook HQ.....	27
The Torpedo Factory Art Center.....	29
Lincoln Park Cultural Center.....	31
3.3_Conclusion.....	32
<b>Chapter 4</b>	
<b>Methodology:</b> .....	<b>33</b>
4.1_Overview.....	33
4.2_Site.....	33

4.2.1_Historical Context.....	37
4.2.2_Regulated and Cultural Contexts.....	38
4.2.3_Physical Context.....	40
4.3_Programmatic Strategy.....	43
4.4_Individual Programmed Spaces and Approximate Square Footages.....	45
<b>Chapter 5</b>	
<b>Design.....</b>	<b>47</b>
5.1_Design Strategy.....	47
5.2_Design Process.....	49
5.3_Design Product.....	59
5.4_Design Purpose.....	67
<b>Chapter 6</b>	
<b>Findings.....</b>	<b>81</b>
<b>Bibliography:.....</b>	<b>85</b>

# List of Figures

Figure 1.1.1_Erector set advertisement .....	10
Figure 2.1.1_Cathedral Of St. Etienne Bourges France.....	12
Figure 2.1.2_Ilja Grawert, master violin maker.....	13
Figure 2.2.1_Ford's "Prefect Assembly Line" .....	16
Figure 2.2.2_Nissan Robotic Assembly Line.....	17
Figure 2.2.3_Typical office layout of the late 20th century.....	18
Figure 2.2.4_Box office movie poster for the film <i>Office Space</i> .....	19
Figure 2.3.1_The iPhone 3G.....	21
Figure 2.3.2_1960 BMW R60 Headlight Assembly.....	23
Figure 2.3.3_2005 Volkswagon GTI Headlight Assembly.....	23
Figure 2.4.1_The consumer .....	24
Figure 2.4.2_The user.....	24
Figure 2.5.1_Black Friday shoppers.....	26
Figure 3.2.1_ Facebook HQ.....	28
Figure 3.2.2_The Torpedo Factory Art Center.....	30
Figure 3.2.3_Lincoln Park Cultural Center.....	32
Figure 4.2.1_Regional map showing site location.....	33
Figure 4.2.2_Aerial view of site looking east.....	34
Figure 4.2.3_Aerial view of site looking south.....	34
Figure 4.2.4 Photos of existing parking garage.....	35
Figure 4.2.1.1_Skid row (Now Yessler Way) 1850.....	37
Figure 4.2.1.2_Pioneer Square and the Seattle Hotel 1925.....	37
Figure 4.2.2.1_Craft and social venues around Seattle.....	38
Figure 4.2.2.2_619 Western.....	39
Figure 4.2.2.3_The Polson Building.....	39
Figure 4.2.2.4_The Northwest Fine Woodworking Gallery.....	39

Figure 4.2.3.1_Site section looking north.....	40
Figure 4.3.2.3_Interior photos of existing structure.....	41
Figure 4.3.2.2_Existing structural plan and section.....	41
Figure 4.2.3.4_Site visibility and contextual relationships.....	42
Figure 4.3.1_Conceptual rendering of spatial relationships.....	43
Figure 4.3.2_Conceptual diagram of program interaction.....	44
Figure 4.4.1_Relative sizes of programmed space.....	46
Figure 5.1.1_Walnut plank.....	48
Figure 5.1.2_ 'Sunken Ship Parking Garage.....	48
Figure 5.2.1_Conceptual beginnings.....	49
Figure 5.2.2_Massing studies.....	51
Figure 5.2.3_Existing structure.....	53
Figure 5.2.4_Existing structure to remain.....	53
Figure 5.2.5_Removed Structure Diagram.....	54
Figure 5.2.6_Saw cutting and removal of structure.....	54
Figure 5.2.7_Shoring of existing structure to remain.....	54
Figure 5.2.8_Addition of new structural members.....	55
Figure 5.2.9_Addition of new floor slabs.....	55
Figure 5.2.10_Tectonic diagram of new vertical structure.....	56
Figure 5.2.111_Addition of new roof structure.....	57
Figure 5.2.12_Addition of enclosure.....	57
Figure 5.2.13_Diagram of voronoi cell roof structure.....	58
Figure 5.2.14_Tectonic diagram of voronoi cell structure.....	58
Figure 5.3.1_Birds eye view looking south.....	60
Figure 5.3.2_Section perspective.....	61
Figure 5.3.3_South elevation.....	62
Figure 5.3.4_North elevation.....	62

(This page intentionally left blank)

Figure 5.3.5_East elevation.....	62
Figure 5.3.6_Lower level floor plan.....	63
Figure 5.3.7_Ground floor plan.....	64
Figure 5.3.8_Upper level floor plan.....	65
Figure 5.3.9_Roof and loft level plan.....	66
Figure 5.4.1_Perspective from Pioneer Square at dusk.....	67
Figure 5.4.2_Perspective of workshop interior.....	69
Figure 5.4.3_Perspective from Yesler and 2nd.....	71
Figure 5.4.4_Perspective of auditorium space.....	73
Figure 5.4.5_Perspective of voronoi cell roof.....	75
Figure 5.4.6_Perspective towards exhibition space.....	77
Figure v of main atrium gallery space.....	79
Figure 6.1_Final thesis defense.....	82
Figure 6.2_Re-articulation of conceptual beginnings.....	83

**the** *Tradition* **of**  
**MAKING**  
AN URBAN CRAFT AND CULTURAL CENTER IN SEATTLE'S PIONEER SQUARE

Thesis by:  
Stephen Shatswell

Committee members:  
Brian McLaren  
Gundula Proksch

# Prologue

*The world can only be grasped by action, not by contemplation. The hand is the cutting edge of the mind.*

*-Jacob Bronowski, The Ascent of Man*

Mankind shares a common disposition; we are by nature cultivators: curious of the world around us, driven to understand it, and determined to shape it to our purposes. This nature dictates our contemplation, comprehension, and action, and causes a desire within each of us to engage deeply in all three. The faculties of the mind are translated into reality by the tool of our hands. They are the final vindication of our existence. They allow us to take Descartes' epiphany a step further: "I think, therefore I am" - I am, therefore I make.

# Chapter 1

## Introduction:

### 1.1\_The Tradition of Making

In the wake of the industrial revolution, and in the information age that has followed, the fundamental notion of man as maker has been stifled in favor of convenience and profitability. Just as industrialization gave birth to consumerism, consumerism has marked the death of the tradition of making. Sand boxes and trade schools have been replaced by video games and standardized testing. It was not long ago when products came with part manuals and could be repaired when broken, or when the most popular toys were kits of parts which allowed imagination and creation to be explored and exercised in unison. (Figure 1.1.1) Craft and durability as the pinnacles of product development now fall secondary to newness and accessibility. The shift towards a knowledge-based economy has marginalized those who are employed in the trades, and pigeon-holed the masses into the cubical-drone jobs of western

society. What has been diminished in this transition is not simply the ubiquitous ability to make, it is the desire and means to deeply engage the world through motive and action. By the compartmentalization and systemic devaluing of process within both manual and intellectual professions, the validation of work has been besieged by the monotony of labor.

The intent of this thesis is therefore to identify the inherent values of the maker within the tradition of making, and examine how they might be defined and articulated to a contemporary society. Through these observations, the notion of an urban craft center will be proposed. The selected site for this program is the 'sunken ship' parking garage in Seattle's Pioneer Square district. The rationale behind this selection is three fold: Firstly, the urban context of the site offers the greatest

opportunity and leverage for attaining the programmatic objectives of this thesis. Secondly, the historical context of the site provides precedent for the types of cultural interventions that will be proposed. Lastly, the physical context of the site allows for the strategies and accessibility needed for the programmatic functions and relationships to be realized.

The goal of this urban craft center is to reintroduce its users to the lost values of making. In essence, the center will exist to establish and elevate this forgotten tradition; it will serve as an outlet for explorations in the tangible, as to illustrate the process of working with all three facets that make us most human: the head, the heart, and the hands.

# BOYS! Get **ERECTOR**<sup>®</sup> and build hundreds of action models

Put together these gleaming STEEL precision parts and create hundreds of toys! Illustrated "How to Make 'Em" book in every set. But you can do your own inventing! Models whistle, "choo-choo," light up and puff smoke. Tell Dad you want ERECTOR and see displays at stores. For ERECTOR and Gilbert Toy Book (plus American Flyer trains) write Gilbert Hall of Science, Dept. G, Erector Square, New Haven 5, Conn. Enclose 10¢ for handling, postage.

**Make this high-swinging airplane ride with ERECTOR No. 6½.**  
No. 6½ has over 350 parts — sturdy girders, gears, wheels, etc. "Powerhouse" electric engine features many speeds (including reverse) to put *action* into your models. Builds pile driver, elevator, lift bridge, hundreds of other wonderful toys that work. \$12.95\*

**Square Girder Construction**  
Precision-matched parts easily lock together with nuts and bolts. Can't wobble or warp. Build bridges that hold more than 200 pounds. Parts have lasting gleam.

**Huge ferris wheel turns fast or slow; reverses. Made with ERECTOR No. 8½.**  
The all-electric set (No. 8½) has nearly 16 lbs. of parts! Includes 4-speed forward and reverse electric engine, electric lights, electromagnet! Build a mighty crane, oil drilling rig, portable derrick, etc. Heavy gauge steel chest. \$23.50\*

\*ERECTOR prices slightly higher Denver and West

Figure 1.1.1\_Erector set advertisement  
From the A. C. Gilbert Company 1930

# Chapter 2

## Theoretical Framework:

### 2.1\_The Inherent Value of the Maker as Craftsman

*The bitterness of poor craftsmanship remains longer than the sweetness of a low price*

-Anonymous

It could be said that you don't need a reason for cake; however this would merely point to the understanding that cake is good, and therefore all reasons for baking it are valid. There could be a birthday, a wedding, a craving, or a baker could simply be practicing their trade. Either way, cake is made, and cake is eaten. The relationships between baker and eater illustrate the attributes of making; intrinsic in the act is process, product, and subsequently purpose. As seen in the making of a cake, purpose can be found in both the process of the baker, and in the reason for the product (which is to be eaten). Moreover this purpose always encompasses needs and motives, and therefore carries implications for individuals.

The connection between making and people establishes the necessary foundation

for affirming the inherent value of the maker. *Homo faber*, or 'man the maker' is a reference to mankind's abilities and attitudes towards fabrication. In Hanna Arendt's, *The Human Condition*, we are given an exhaustive description of his inclinations<sup>[1]</sup> within the *vita activa* (activities of life). Most pointedly for the purpose of finding value, *homo faber* exhibits a "confidence in tools and in the productivity of the maker of artificial objects".<sup>[2]</sup> The assertion

---

1. "[H]is instrumentalization of the world, his confidence in tools and in the productivity of the maker of artificial objects; his trust in the all-comprehensive range of the means-end category, his conviction that every issue can be solved and every human motivation reduced to the principle of utility; his sovereignty, which regards everything given as material and thinks of the whole of nature as of "an immense fabric from which we can cut out whatever we want to reweave it however we like"; his equation of intelligence with ingenuity, that is, his contempt for all thought which cannot be considered to be "the first step . . . for the fabrication of artificial objects, particularly of tools to make tools, and to vary their fabrication indefinitely"; finally, his matter-of-course identification of fabrication with action."; Arendt, Hannah. *The human condition*. Chicago: University Of Chicago Press, 1958, p.305

2. Arendt, p. 305

of productivity presumes intentionality and therefore establishes within the act of making a connection between thinking and doing. If *homo faber* is to be found as valuable, there must be worth in both his motives and actions.

For this reason, it is necessary to qualify and thereby clarify what is meant by the inherently valuable maker. The word “making,” embodies a host of human actions. One can be making a table or making a film, just as well as they can be making up time, making love, or making someone’s day. With such versatility, ‘the tradition of making’ (from which this paper draws its title) invokes much more than a craft handed down from master to apprentice. Something explicitly traditional merits a consideration of worth because it is counted among that which should be preserved for future generations (Figure 2.1.1). In this light, the tradition of making gives a sense of validation to the action; it implies the act of doing something well. Richard Sennett in his book, *The Craftsman*, uses the word ‘craftsmanship’ to embody this idea. Craftsmanship, as he describes, “names an

enduring, basic human impulse, the desire to do a job well for its own sake.”<sup>[3]</sup> Bronowski affirms this proclivity towards excellence as the, “most powerful drive in the ascent of man”; “He loves to do what he does well and, having done it well, he loves to do it better.”<sup>[4]</sup> The title of craftsman, therefore, includes *homo faber* within the broader framework of man-as-cultivator. Our disposition towards contemplation, comprehension, and control infers a desire for quality. This desire, which the craftsman possesses, establishes a qualitative foundation of worth within his motives.

The second merit of worth within the craftsman’s motives are in his access to ethics and morality. Creativity and productivity are standard ideals of the craftsman insofar as they express his mastery of process. The ability to comprehend, manipulate, and refine process is a prerequisite in his ability to subjectively and objectively define purpose.

3. Sennett, Richard. *The craftsman*. New Haven: Yale University Press, 2008, p. 9

4. Bronowski, Jacob. *The ascent of man*. [1st American ed. Boston: Little, Brown, 1974.



**Figure 2.1.1\_Cathedral Of St. Etienne Bourges France**  
The structural advancements and aesthetic principals realized through the methods and experimentations in gothic cathedrals have played an integral role in the evolution of architecture.



Figure 2.1.2\_Ilja Grawert, master violin maker

*All craftsmanship is founded on skill developed to a high degree. By one commonly used measure, about ten thousand hours of experience are required to produce a master carpenter or musician. Various studies show that as skill progresses, it becomes more problem attuned, like the lab technician worrying about procedure, whereas people with primitive levels of skill struggle more exclusively on getting things to work. At its higher reaches, technique is no longer a mechanical activity; people can feel fully and think deeply what they are doing once they do it well.<sup>[5]</sup>*

A Craftsman's intimate familiarity with process allows a shift of focus from means to end. This freedom introduces a broad perspective in the ability to simultaneously consider the *what*, the *how*, and the *why*. Ethics therefore becomes an issue relevant to the craftsman's pursuit. By fully engaging from the identification of a problem, to the execution of a product solution, the Craftsman is forced to apply his moral ontology in a holistic fashion. Furthermore, these 'big picture' considerations and decisions are given a trajectory by his proclivity towards doing a job well. This explanation of the maker-as-craftsman's *why*, grants a philosophical

---

5. Sennett, p.20

foundation of worth in his motives.

Craftsmanship in Sennett's sense does not omit activities or professions categorically (for example: manual versus intellectual), but rather points towards approaches and quality within each of them. However, by limiting the notion of the craftsman momentarily to physical practice, we find additional worth in the tangible nature of their work. By being so anchored, the physical maker is self-edified in their actions.

Matthew Crawford in his book, *Shop Class as Soulcraft*, describes how a craftsman's actions attribute value:

*They seem to relieve him of the felt need to offer chattering interpretations of himself to vindicate his worth. He can simply point: the building stands, the car now runs, the lights are on. Boasting is what a boy does, who has no real effect in the world. But craftsmanship must reckon with the infallible judgment of reality, where one's failures or shortcomings cannot be interpreted away.<sup>[6]</sup>*

The very act of making or repairing physical objects, implies a submission to and

---

6. Crawford, Matthew B.. *Shop class as soulcraft: an inquiry into the value of work*. London: Penguin Books, 2010. p. 15

understanding of natural laws and properties. Crawford's, 'infallible judgment of reality,' points out the objective success (or failure) of a product. As we have seen, purpose is implicit in product (for example: a cake tastes good, and a house provides shelter). Therefore, the explicit success of a product displays its worth insofar as its fulfilling of purpose. Subsequently, a craftsman that can produce things that work, has an inherent level of self-edified value.

In addition, the craftsman of physical objects has inherent worth through his understanding of the natural world. There is a familiarity with how things work that develops when one regularly engages in the process of making. Sennett notes that in addition to this engagement, "Repair is a neglected, poorly understood, but all-important aspect of technical craftsmanship...Put simply, it is by fixing things that we often get to understand how they work"<sup>[7]</sup>. A tailor, for example, would likely have more confidence in fixing a leaky faucet than a bank manager who has never

owned a wrench. By understanding the natural world, the craftsman sees how technology pragmatically defines our limits and delimits in everyday life. Knowing how objects and amenities function within the laws of physics produces what Crawford calls a, "master[y] of one's own stuff". The helpless dependency lay-users have on objects is always predicated upon an ignorance of how they work. The craftsman's empathy for objects and materials afford him a level of control over his environment, and a freedom from the limitations imposed by ignorance.

Moreover, as in the self-edification of a physical object fulfilling purpose, the act of engaging the world around us speaks to our validation as physical beings.

*Thinking about manual engagement seems to require nothing less than that we consider what a human being is. That is, we are led to consider how the specifically human manner of being is lit up, as it were, by man's interaction with the world through his hands.<sup>[8]</sup>*

---

7. Sennett, p.199

---

8. Crawford, p. 63-64

Acknowledging that we as humans are physical beings, points towards a necessity of physical interaction. This interaction is the only means by which we can actively experience and influence our environment. Therefore, the measure of a physical craftsman's worth is not just in his production of purpose-fulfilling objects, but in his adept engagement and control at the base level of the human experience.

As we have seen, the inherent value of the maker-as-craftsman is derived from worth found in his motives and actions. He exhibits qualitative worth in his 'desire to do a job well for its own sake', philosophical worth in his access and obligation to ethics, self-edifying worth in his repair and production of useful objects, and inherent worth in his fundamental engagement with the physical world. From this understanding, we are able to examine how modern economics and culture have made the *tradition of making* obsolete and alienated the maker-as-craftsman. The problems produced by this state are most clearly seen through investigating the contemporary devaluing of the three implicit

aspects of making: process, product, and purpose. Moreover, by considering how each of these devalued aspects have affected individuals, the paradigm shifts necessary for resolution will become clear. These shifts will produce a framework for programmatic and architectural responses and objectives.

## 2.2\_The Systemic Devaluing of Process

Sennett's notion of 'doing a job well for its own sake' allows the Craftsman to admonish quality and skill within the whole spectrum of professions. Likewise the systemic devaluing of the modern process of making extends to both the manual and intellectual genres of the workforce. The primary factors of this devaluation are seen in the dismantling and compartmentalization of process. By investigating how this systemization took place in each field, it becomes apparent how both are subsequently devoid of the liberties needed for makers and workers to operate as craftsmen. As a result, the maker is reduced to a laborer, and rendered incapable of exercising the motives

and actions necessary to uphold the *tradition* of making.

The creation of the assembly line represents the primary shift in manual production during the last few centuries. The first and second industrial revolutions of the eighteenth and nineteenth centuries established the economic and social atmospheres, and the technological capacities needed for mass production to

become a reality. Prior to these factors, the demand for, and ability to create large quantities of what are now considered basic items (such as dining room chairs and kitchen sinks) was simply non-existent. One of the better known pioneers of the assembly line method is the Ford Motor Company. (Figure 2.2.1) When Ford first began manufacturing through the assembly line in the early twentieth century, the effects it held



Figure 2.2.1\_Ford's "Perfect Assembly Line"  
1950's, Dagenham site, just east of London near the river Thames



Figure 2.2.2\_Nissan Robotic Assembly Line  
Campton Plant 2009

on production volume were vast. In 1895, there were approximately 300 cars in the whole of the United States. That number jumped to 78,000 by 1905, 459,00 by 1910 and 1.7 million by 1914.<sup>[9]</sup>

This new standard of mass production did far more than drive manufacturing technologies. (Figure 2.2.2) Workers in particular had their roles within the production process completely reinvented. Frank Gilbreth displayed the earliest signs of this shift in his 1910 book, *Motion Study: A Method for Increasing the Efficiency of the Workman*. In this pioneering work for the field of management engineering, Gilbreth meticulously broke down the physical movements involved in bricklaying. Though his intentions were for the sake of safety, efficiency, and economy in the field of masonry, his scientific study of motion mechanics would prove to be more than compatible with the assembly line mentality. Shortly thereafter in 1915, Fredrick Winslow Taylor advocated this connection through his discussion of the benefits these

9. "Automotive production volume statistics" web. accessed 9/17/2011 <<http://www.carhistory4u.com/the-last-100-years/car-production>>

studies would offer in terms of productivity. In his book, *The Principles of Scientific Management*, he presents the idea of using humans as machines. By employing workers solely for their physical potential, they are relieved of the need for cognitive engagement. This limitation is intended to enhance productivity through job simplification. Taylor states that, "All possible brain work should be removed from the shop and centered in the planning or laying-out department..."<sup>[10]</sup>

By the dismantling of a comprehensive approach in the mass production mentality, the maker is no longer concerned with the mastery of process, but rather with the execution of tasks. Consequently, the inherent values of the maker-as-craftsman's motives and actions are greatly diluted. Sennett explains that, "when hand and head, technique and science, art and craft are separated... the head then suffers; both understanding and

10. Taylor, Fredrick Winslow. *The principles of scientific management*. Gloucester, Massachusetts: The Echo Library, 2006. p.39

expression are impaired”.<sup>[11]</sup> Furthermore, Crawford adds that “wherever the separation of thinking from doing has been achieved, it has been responsible for the degradation of work”.<sup>[12]</sup> Without the ability to think deeply (or in Taylor’s ideal - to think at all), the maker suffers the loss of qualitative validation; he is greatly limited in his ability to consider a job worth doing well for its own sake. Without his ability to approach a problem through mastery of process and defining of product, his access to ethics are removed and his philosophical validation is lost. Lastly, by having his role simplified to the monotony of repetitive task execution, his engagement with the physical world is no more validating than tying his shoes.

The knowledge-based worker implicitly lacks the self-edifying benefits of physical engagement and tangible production. In addition, however, the intellectual jobs of our modern economy have suffered from process compartmentalization much like the task-

oriented manual trades. (Figure 2.2.3) Following the simplification of human engagement in manual production, ‘blue collar jobs’ (as they are commonly called) incurred a stigma of employing mentally inferior individuals. This perception stimulated a cultural shift towards the notion that technology’s productivity would allow the masses to pursue more ‘intellectually stimulating’ ‘white collar jobs.’ Between the years of 1959 and 2009, the College enrollment rate of recent high school graduates nearly doubled from just over 40% to 71%.<sup>[13]</sup> The unfortunate reality for this new intellectual workforce, however, is that the objectives of mass production (such as efficiency and productivity) have shaped the development of most service and information-based industries as well. Crawford notes that the de-skilling of white collar jobs occurred, “by the same logic that hit manual fabrication a hundred years ago: the cognitive elements of the job are appropriated from professional, instantiated in a system or process, and then handed back to



Figure 2.2.3\_Typical office layout of the late 20th century

11. Sennett p.9

12. Crawford p.37

13. US Bureau of labor statistics. “College Enrollment and Work Activity of 2010 High School Graduates.” April 8, 2011. Web. December 11, 2011. < <http://www.bls.gov/news.release/hsgec.nr0.htm>>



Figure 2.2.4\_Box office movie poster for the film *Office Space* (1999) directed by Mike Judge. The film is a comedy which follows a begrudged office employee and his rebellion against the system.

a new class of workers - clerks - who replace the professionals".<sup>[14]</sup> The same pitfalls of the devalued manual processes are apparent in the intellectual processes of knowledge-based work. The holistic approach and mastery of process which enabled the craftsman to engage intellectually, has been stifled in the intellectual job market for the sake of efficiency and profitability.

A young financial entrepreneur example may well have ambitions that encompass the development of an investment fund, the accumulation of investors, the reading of the markets, and the execution of decisive actions in response to his deep understanding of all three. The near impossibility of this dream, however, is due to the fact that massive financial institutions can work much more efficiently on the micro scale through extreme specialization. The existence of workers whose entire job is to collate market data, so the analysts can interpret it to inform the traders so the firm can profit and the sellers can accumulate more investors,

---

14. Crawford p.44

ensures that our young entrepreneur's all-encompassing role is simply untenable.

Just as in task-orientation, specialization limits workers' access to ethical and qualitative validation. In the example of the financial institution, consider the cold-calling product seller. This person would be incapable of preventing insider trading within the firm. More than likely, their aim is at least to meet their quota of calls, and at most to sign as many investors as possible to receive a larger bonus check. Their ethics extend only so far as what they're willing to say for profit, and their quality reaches only so high as efficiency allows.

Crawford notes that the systemization of process, "replaces what was previously an integral activity, rooted in craft tradition and experience, animated by the worker's own mental image of, and intention toward, the finished product."<sup>[15]</sup> In essence, the mass production mentality articulates a disregard for the what, in favor of the how. Mastery and

---

15. Crawford, p.39

obsession stand in stark contrast. The craftsman masters the processes of his trade so that his execution is transparent against the opacity of product and purpose. The assembly line, however, is fixated on the mastery of fabrication so that efficiency, productivity, and profitability might be shown. What was once intended to be invisible, is now proudly on display.

Arendt explains the shift towards systemization in terms of “work” versus “labor.” Work is always productive in its concern with generating objects of permanence. Utility is its focus, and its action is always a means towards an end.

*Unlike the productivity of work,... the productivity of labor power produces objects only incidentally and is primarily concerned with the means of its own reproduction...*

*It is indeed the mark of all laboring that it leaves nothing behind, that the result of its effort is almost as quickly consumed as the effort is spent. And yet this effort, despite its futility, is born of a great urgency and motivated by a more powerful drive than anything else, because life itself depends on it.<sup>[16]</sup>*

The metric of ‘labor power’ evaluates Taylor’s ‘isolated physical potential’. This is appropriate in light of Arendt’s definition of labor, because it describes more than just a unit of measure. Labor-driven societies can only be supported through mass production. Therefore, the paradigm shift from the maker-as-craftsman to the maker-as-laborer, encompasses and describes the loss of inherent value. As we have seen, the systemization of process dilutes and prevents the makers qualitative and philosophical validations of motive, and his self-evident validations of action.

---

16. Arendt, p.99

### 2.3\_The Comprehensive Devaluing of Product

The transition from work to labor has implications regarding the second intrinsic aspect of making as well: the product. The primary objective of mass production is to *efficiently* fabricate goods at a high enough quantity to lower their cost to the buyer. However, with the emphasis of production shifting from the *what* to the *how*, it is correct to infer that the *inherent* values of products have

declined as well. The 'comprehensive devaluing of products' thus includes more than just monetary considerations, but also the inherent product values of utility and durability.

The devaluing of utility and durability develop primarily through the effects of the labor model of production. As we have seen, labor exists solely to perpetuate life. Subsequently, objects produced through the labor model must quickly be consumed to make room for future

## iPhone 3G



**Figure 2.3.1\_The iPhone 3G**  
which was released by Apple in July of 2008. By July of 2011 this model had been made obsolete by the subsequent releases of the the updated 3Gs, 4G, and 4Gs.

products in the market. An appliance company, for example, can only sell toasters to people who need them. The requirement of demand, therefore, incentivizes limiting the lifespan of their toasters. The control of a product's lifespan is exercised through two methods: intentional reductions in utility through planned obsolescence, and intentional reductions in durability through limited repairability.

Planned obsolescence refers to the strategy of designing products that will be functionally, technologically, or stylistically inferior to future planned products. (Figure 2.3.1) Limiting utility in this way, is done to increase the frequency of return customers. By planning for obsolescence, a manufacturer is also afforded a benchmark for value engineering a product's material and fabrication costs. If the appliance company, for instance, knows that they are planning on releasing a new model of their toaster with a cancel button and a bagel toasting function in 3 years, they might save on fabrication costs by intentionally engineering the quality of the current model to last only

for that long. Planned obsolescence, therefore, produces both a limiting of utility and an intentional degradation of quality.

The issue of reduced durability through limited repairability stems from two factors: repair costs, and repair feasibility. Repair costs operate as a limiter when they are higher than the cost to replace. Since the intended results of planned obsolescence and value engineering are that an object would have a limited life span, it is often much cheaper to replace a product than to repair it. Repair feasibility is an issue dictated largely by modern construction techniques. Plastics engineering and injection molding, along with automated fabrication and assembly have become the technological vehicles of mass production in the last few decades. These methods have hugely reduced the cost of everyday items through part conglomeration, assembly precision, and reductions in human labor. The implications this has on repair feasibility, however, is that products are much less accessible to human repair and maintenance. Consider, for example,

the differences between a headlight from 1960 and a headlight from 2005. (Figures 2.3.2 & 2.3.3) Were a lens to crack in the early model, the owner could disassemble the casing and replace the single part. In the new model, however, if the lens were to crack the owner would have to replace nearly the entire headlight.

Planned obsolescence and limited reparability therefore dictate product design in

the labor-driven market. These factors exercise a controlled reduction in the inherent values of product utility and durability. To understand how the comprehensive devaluing of product impacts individuals, however, the focus of discussion must shift from the product itself to the people who purchase them.

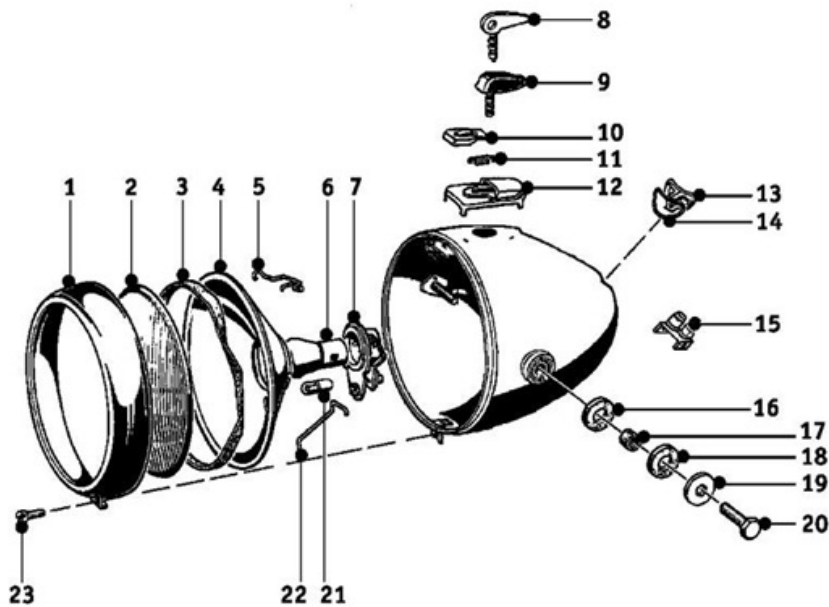


Figure 2.3.2\_1960 BMW R60 Headlight Assembly

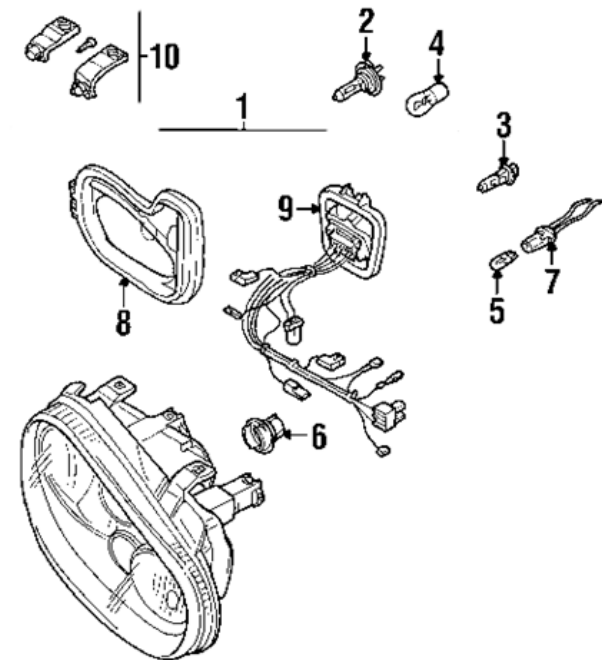


Figure 2.3.3\_2005 Volkswagen GTI Headlight Assembly

## 2.4\_The Impaired Consumer's Ignorance of Value

This leads finally to the third intrinsic aspect of making: purpose. As we have seen in the labor model, all production exists solely to perpetuate life. Within this framework, a paradigm shift occurs from users to consumers. In contrast to the user's disposition to supplement life with the utility of products, the consumer's proclivity is to experience life through their consumption. (Figures 2.4.1 & 2.4.2) So long as this consumption occurs quickly enough, the healthy life cycle of the market is allowed to continue. It follows then, that the primary purpose for making in the modern context is to feed the consumer. This role as the purpose of labor, inevitably leads to 'the impaired consumer's ignorance of value.'

Just as labor and its propensity for mass production is dependent on the consumer to function, the consumer is dependent on the products of labor to exist. The consumer is impaired by this mutual dependency through the bombardment of marketing and social pressures

to remain in and fulfill his role. Consumerism is dependent on dissatisfaction; the consumer must always have a desire to purchase. The allure of a product's 'newness' must therefore be seen as favorable over inherent utility. The irony of this perception is that the attribute of newness is often presented as utility through the promise of an increased level of freedom and happiness. Crawford notes that,

*There seems to be an ideology of freedom at the heart of consumerist material culture; a promise to disburden us of mental and bodily involvement with our own stuff so we can pursue ends we have freely chosen. Yet this disburdening gives us fewer occasions for the experience of direct responsibility. I believe the appeal of freedomism, as a marketing hook, is due to the fact it nonetheless captures something true. It points to a paradox in our experience of agency: to be master of your own stuff entails also being mastered by it.<sup>[17]</sup>*

Crawford's paradox explains the consumer's impairment as an enslavement to the promise of freedom. Moreover, this freedom that is promised through the accumulation of newer, faster, bigger, and better things, preys on

17. Crawford, p. 56-57

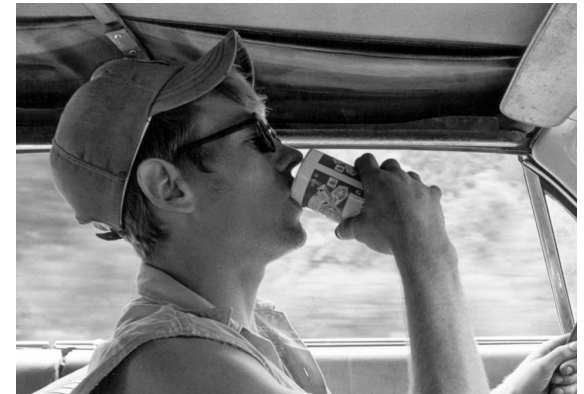


Figure 2.4.1\_ The consumer  
Experiencing life through product consumption.

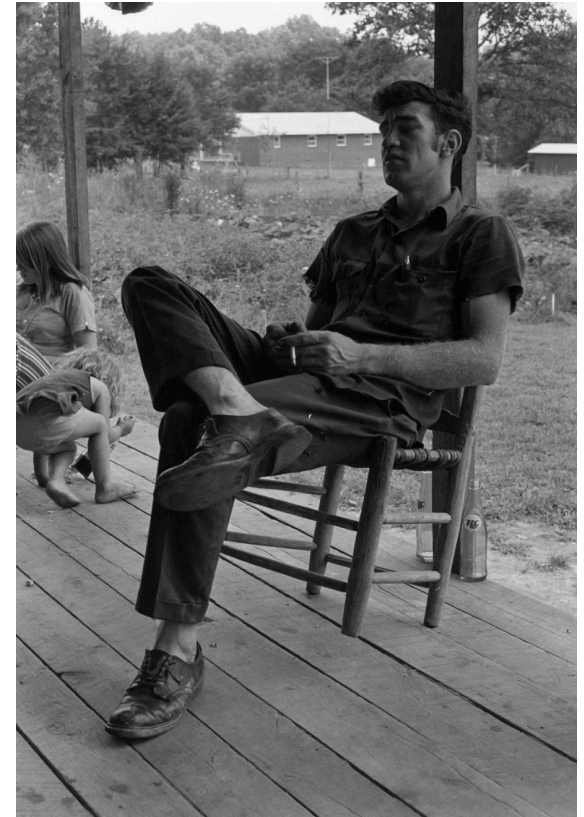


Figure 2.4.2\_ The user  
Supplementing life through the utility of products.

the human disposition of man as cultivator. There is a gap in the notion that the accumulation of stuff will satisfy our desire to engage life through deep understanding and purposeful action. In short, this impairment produces an ignorance of value.

The maker-as-craftsman has been shown to embody the inherent values of motive and action within the tradition of making. Arendt notes, however, that in light of the consumer mentality, "Nothing perhaps indicates clearer the ultimate failure of *homo faber* to assert himself than the rapidity with which the principle of utility, the very quintessence of his world view, was found wanting and was superseded by the principle of 'the greatest happiness of the greatest number'". Labor and consumerism, have replaced the value-measure of engagement and utility with happiness. "The amount of pain and pleasure experienced in the production or in the consumption of things,"<sup>[18]</sup> pacifies the desire for inherently valuable processes and products. The consumer does not care if their work is validating

---

18. Arendt, p. 308-309

or engaging, because the incentive of labor is solely to accumulate more stuff. Sennett notes in, *The Culture of the New Capitalism*, that "The craftsman is proud of what he has made, and cherishes it, while the consumer discards things that are perfectly serviceable in his restless pursuit of the new."<sup>[19]</sup> Moreover, he has been lied to by the marketing of dissatisfaction that *new* stuff will validate and satisfy his purpose. His ignorance of value is derived from his gullibility.

## 2.5\_ Theoretical Conclusions

The inherent values of the maker-as-craftsman and the tradition of making have been stifled through the repercussions of consumerism and the labor-driven markets of mass production. *Homo faber* has experienced his decline through the systemic devaluing of process and the comprehensive devaluing of product; both of which have produced the impaired consumer and his ignorance of value. These conclusions are summed up in the paradigm shifts of worker to laborer, and user to

---

19. Sennett, Richard. *The culture of the new capitalism*. New Haven: Yale University Press, 2006.

consumer. The laborer is unable to operate with inherently valuable motives and actions. The compartmentalization of process eliminates his desire to do a job well for its own sake, prevents his access to ethical considerations, and invalidates his engagement with the physical world. The limited utility and reparability of products produces the consumer's dependence upon them, and prevents their engagement in the illustrative act of fixing.

The impetus of this thesis is subsequently to enlist architecture as a catalyst for the mitigation of these paradigm shifts. Having discussed the values of the craftsman and outlined the factors leading to his alienation, the objective moving forward is to examine how they might be rediscovered and articulated in a contemporary society. The pedagogy of architecture and the amenities of program will serve to house and inform the investigation of craft. The engagement of culture through multiple means will serve to identify craft in a wholistic fashion, galvanizing its significance. It is only by giving this forgotten tradition a

relevant and clear voice, that its lessons might admonish the culture of consumerism in which we find ourselves so steeped. (Figure 2.5.1)



Figure 2.5.1 \_Black Friday shoppers clamoring over digital cameras on the biggest retail day of the year.

# Chapter 3

## Precedent Analysis:

### 3.1\_Precedent Selection Rationale

In light of these theoretical conclusions we are able to begin a transition towards a pragmatic approach, particularly in regards to the program of this thesis. Prior to discussing specific functions, however, it is necessary to establish a programmatic framework and rationale through precedent study. As discussed, the objective of this thesis is to define and articulate the values of craft to contemporary society. The scope of the project should therefore engage on the professional, social, and individual levels. These three typologies appropriate precedents of professional practice, social amenity, and individual education pertaining to the tradition of making.

### 3.2\_Precedents

#### Facebook HQ

Palo Alto, CA  
Studio o+a 2009

The recently opened headquarters for the social media giant Facebook, implements strategies reminiscent of the company's networking services. The office is located in what was previously a 150,000sf advanced technology manufacturing plant in California's 'Silicon Valley'. The layout of spaces fosters community through open floor layouts, shared support spaces, and ubiquitous day lighting strategies. With more than 700 employees contained within the complex, interaction is encouraged through physical, visual, and spatial connectivity. The facility employs the re-use of the industrial structure and materials as a unifying element, and partitions the new program spaces with interventions of a complimentary palette. The character of what once was, thus adds to the

vibrancy and cohesion of this newly activated space. The headquarter's clearly-designed emphasis on (real) 'social networking' within the company, produces both intentional and accidental interactions within a professional setting. These interactions allow for the sharing of information, the development of relationships, and the building of an organic community.



**Figure 3.2.1\_ Facebook HQ**  
 (top left) casual meeting spaces  
 (top right) conference space  
 (lower left) repeating daylight and view bays  
 (lower right) open office space

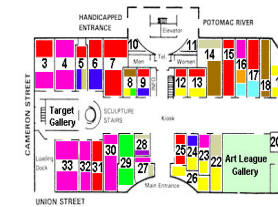
## The Torpedo Factory Art Center

Alexandria, VA

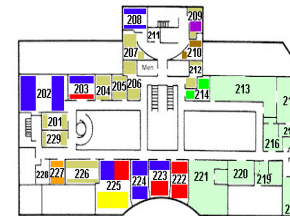
Built in 1918, the Torpedo Factory was a primary manufacturer of naval and air force torpedoes during the second world war. When peace was declared in 1945, the factory ceased operations and transitioned into a storage facility. In the early 1970's, the facility was cleaned of its wartime debris and re-purposed as a network of artist studios and gallery spaces. The Torpedo Factory Art Center (TFAC) first opened its doors to the public in 1974, and underwent a complete interior renovation for a grand reopening in 1983. In its current capacity, the center houses over 160 professional artists who work, exhibit, and sell their art. According to their mission statement, they exist to “enhance public art appreciation and education by providing the opportunity to visit working art studios and artist cooperatives, and to take classes.” In essence, the TFAC operates as a cultural center and a market place dedicated to elevating fine art through artist employment, and public engagement and education. By generating an intersection

of community and fine art, the center offers a social outlet broad enough to address cultural perceptions of craft.

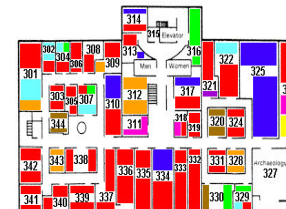
First Floor



Second Floor



Third Floor



The Torpedo Factory has 3 levels of 82 artist studios and 6 galleries. Find where your favorite kind of art is located before your visit by checking the color coded floorplans below and then clicking on the studio to see the art.

- Ceramics
- Collage/Mixed Media
- Enamelling
- Fibers
- Glass
- Jewelry
- Painting/Drawing
- Photography
- Printmaking
- Sculpture
- The Art League



**Figure 3.2.2\_ The Torpedo Factory Art Center**  
 (opposite page) types and layout of artist spaces  
 (top left) wartime interior of torpedo factory  
 (top right) renovated interior of artist spaces  
 (lower left) wartime exterior  
 (lower right) renovated exterior



## Lincoln Park Cultural Center

Lincoln Park, Chicago, IL

Located on the north-side of Chicago proper, the Lincoln Park Cultural Center offers urban residents a variety of cultural and recreational programs. Counted among these cultural assets, are educational classes and shared community workshops dedicated to the dissemination of craft knowledge. Residents of Chicago are given access to wood and metal shops, ceramics studios, and glass shops as a means to learn about and engage in the material arts. The facility also provides art galleries, craft and flea market venues, and performance spaces, all open to public interaction and utilization. Annual art fairs held at the complex feature a wide variety of local art vendors, child studios, audio and visual entertainment, and local food vendors. The commitment of the center to educate and enable urban residents to explore physical art and fabrication, speaks to its regard of individuals' craft knowledge and abilities as a cultural necessity.



### 3.3\_Conclusion

The precedents established by these three projects validate the idea of architecture as a catalyst for cultural change, particularly in regards to the problems presented within the theoretical frameworks of this thesis. The design for this thesis should consider programmatic and spatial queues from each of these typologies as a framework for moving forward. Specifically, this thesis should seek to foster community both spatially and programmatically within the professional realm as seen in the Facebook HQ, it should use its social amenities and engagements as an opportunity to display and support the tradition of making as seen in the TFAC, and it should pursue the dissemination of craft knowledge and ability on the individual level as seen in the Lincoln Park Cultural Center.



Professional



Social



Individual

**Figure 3.2.3\_Lincoln Park Cultural Center** (opposite page)  
 (top left) Weekly outdoor market held during the warm season  
 (middle left) Community woodshop  
 (top right) Artist fair  
 (bottom) Main entrance of Cultural Center

# Chapter 4

## Methodology:

### 4.1\_Overview

Thus far, the thesis goals of reintroducing urban dwellers to the lost values of making have been investigated and established, and precedents pertaining to the fostering of community and its intersection with craft have been studied. We are now able to move forward in the process of establishing and validating more specific thesis goals in regards to the programmatic and design objectives for the site and the building.

### 4.2\_Site

As discussed in the introduction, the proposed architectural intervention for this thesis will be designed on site currently known as the 'Sunken Ship Parking Garage' in Seattle's Pioneer Square. The rationale behind this selection is predicated upon three integral aspects of the site: the historical context, the

cultural context, and the physical context. An investigation of each of these aspects, along with how this thesis' specific site strategies should respond, allows for both a validation of selection, and guidelines for moving forward.

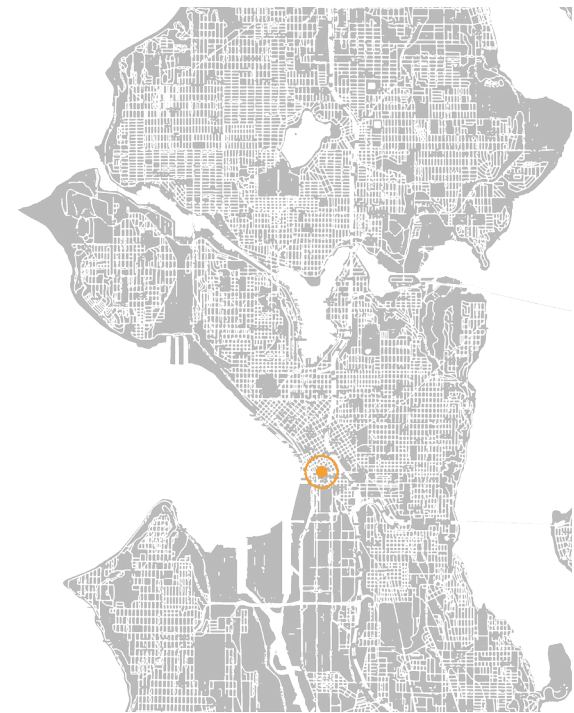


Figure 4.2.1\_Regional map showing site location



Figure 4.2.2\_Aerial view of site looking east



Figure 4.2.3\_Aerial view of site looking south



**Figure 4.2.4** Photos of existing parking garage

(this page)

(top left) View from Yesler Way and 2nd

(bottom left) View from Occidental

(right) View from Pioneer Square

(opposite page)

(left) View from James and 2nd

(top right) View looking up top parking level

(bottom right) View looking towards Occidental Park





Figure 4.2.1.1 \_Skid row (Now Yessler Way) 1850



Figure 4.2.1.2 \_Pioneer Square and the Seattle Hotel 1925

#### 4.2.1\_Historical Context

As Seattle's historic district, Pioneer Square draws much of its appeal and character from its historical context. Originally settled as a logging and shipping community in 1852, the blocks contained in and around Pioneer Square have a long-standing history in craft and trade. What is now Yesler Way, was originally referred to as 'skid row', drawn from its use as a means for sliding logs down to the Yesler mill located on the historic waterfront near present-day Post Alley. (Figure 4.2.1.1) In 1889, much of the buildings in the original Seattle settlement burned to the ground in The Great Seattle Fire. Within a year, the city had begun a complete rebuild and many of the present-day historical buildings were erected. With the planned re-grades which would take place in the early parts of the twentieth century, many of the new structures were built with entrances on the ground and second floors. These lower level entrances can be seen to this day on the historic underground tour.

The site contained by James Street, Second Avenue, and Yesler Way has a long standing history in the context of the historic district. After the Great Seattle Fire, The Seattle Hotel was erected on the triangular site directly adjacent to pioneer place, the small park from which the district draws its name. (Figure 4.2.1.2) By 1961, the historic building was deemed economically un-sustainable by the owner. Due to this under-utilization and the costs of badly needed structural updates, the Hotel was demolished. The 'sunken ship' parking garage (named for its appearance as a ship's bow emerging from the ground towards the Yesler and James corner) was built soon after. The razing of the historic hotel, though viewed as tragic by many Seattle residents and historians, stimulated the creation of historic preservation initiatives and eventually led to the district's inclusion on the National Registry of Historic places.

The historical significance of the site and its context leads to a number of necessary considerations. Seattle's roots as an industry

and trade town establish precedent (which has survived through to modernity, this will be discussed in the cultural context) within the historic district for the display and engagement in craft and the tradition of making. The link the site has to Pioneer Square’s historic preservation establishes a tenuous state of significance for its current function. Ironically, though the site is grossly underutilized as a functional urban asset and a public amenity, the form and spatial character generated by the parking garage has created somewhat of an iconic reverence from the district’s inhabitants. (Figure 4.2.1.3) This reverence should be heavily considered and reflected in the site and design strategies. Finally, the historic context dictates a respect for the various proportions and material typologies used in the surrounding buildings. Though the specific historic preservation guidelines will not be followed by this thesis for the sake of progressive thinking and exploration, there should none-the-less be a sensitivity to the traditional facades, street engagement, and building volumes in the area.

#### 4.2.2\_Regulated and Cultural Contexts

The regulated and cultural context of the site refers to the various zoning legislation, demographics, and significant nearby amenities which validate, challenge, and thereby inform the programmatic and design framework for this thesis. Pioneer Square’s previously discussed historic status has prevented this portion of Seattle from developing in the same way as the rest of the city. While preservation initiatives are invaluable to a city’s ability to maintain its character, the restrictions imposed have stifled the area’s ability to truly flourish despite its proximity to the waterfront, the business district, and the athletic venues of Seattle. (Figure 4.2.2.1) The primary limiting factor of the regulations imposed is the 65’ height restriction for new construction in the area. This limit falls far short of 18 story minimum held by developers and the Downtown Seattle Association; “anything less would fail to jump-start development in a neighborhood that has high retail vacancy rates, a disproportionate share of social services for the poor and homeless, and few middle-income



**Figure 4.2.2.1\_Craft and social venues around Seattle**  
In the area around Pioneer Square, a high density of studios and galleries exist. However, a deficiency of the neighborhood is seen in its lack of social venues.



Figure 4.2.2.2\_619 Western



Figure 4.2.2.3\_The Polson Building



Figure 4.2.2.4\_The Northwest Fine Woodworking Gallery

residents.”<sup>[20]</sup> One might contend that Pioneer square is itself a node of interest, however its limited commercial and residential development has produced the highest density of homeless shelters and soup kitchens, and one of the lowest residential densities in the downtown area.

These factors have at the least encouraged developers to look elsewhere for investment opportunities, and at most given Pioneer square the stigma of an undesirable vagrant hub. Stating this undoubtedly leaves an exaggerated perception which errors on the negative. Anyone who spends much time in the historic district will find that it possesses a character unique from any other part of the city. The positive reality of this demographic deficiency, however, is that it invites residential, commercial, and social intervention. The scope of this thesis seeks to address all three of these typologies. With that in mind, it is worth noting that the restrictions imposed by the scale of the site are accepted and acknowledged limitations

20. Thompson, Lynn. Seattle Times. Pioneer Square: Historic Character Vs. Height. March 9, 2011

of the project. While the design portion will be executed with the intention of fostering development and cultural change, its success would require further intervention within the district to create additional residential and commercial density.

In addition to the historical context and significance, Pioneer square contains a rich culture of art and design. For example, at 619 Western is a complex containing a community of artist live-work studios which open their doors to the public every first Thursday of the month. (Figure 4.2.2.2) The Polson Building on Columbia and Western Avenue contains a number of the several prominent architectural design firms in the area including The Miller Hull Partnership. (Figure 4.2.2.3) The Northwest Fine Woodworking Gallery on Jackson street boasts a large collection of Seattle’s premiere furniture and industrial designers. (Figure 4.2.2.4) These and many other professional studios, galleries, and retail stores in the area establish the contemporary articulation of the districts roots in crafts and trades. The proposed center will

seek to further define and establish this existing culture to encourage a broader engagement of Seattle residents in the tradition of making.

### 4.2.3\_Physical Context

The physical context of the site most directly informs the specific site strategies related to the programmatic and design goals. The 19,000sf lot is surrounded by prominent

streets on all sides. This encapsulation offers both ample opportunity for street presence within the neighborhood, and significant challenges for appropriately locating and designing service access points. Both of these factors should be considered when placing the necessary pedestrian and vehicular access points. With an East - West orientation along its long axis and a 14' slope across the lot, the site has a prominent

Figure 4.2.3.1\_Site section looking north



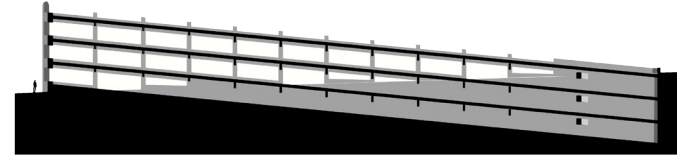
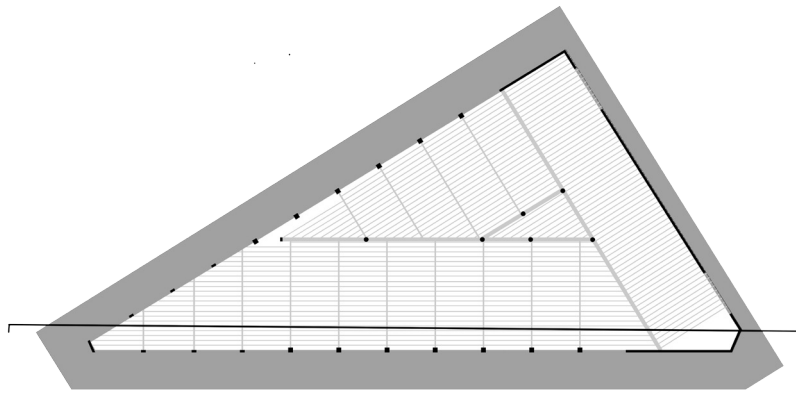


Figure 4.3.2.2\_Existing structural plan and section



Figure 4.3.2.3\_Interior photos of existing structure

relationship with the adjacent buildings and urban spaces. In addition, the site provides excellent views down Yesler towards the water front, has proximity links to Seattle’s public transit system, and allows for ample access to natural day lighting. (Figures 4.2.3.1 & 4.2.3.4) Each of these attributes should contribute to the passive strategies and program layouts employed by the facility.

Consideration of the existing structure is important particularly in regards to the preservation of the historic underground tour, and the iconic spatial form established by the existing volume of the parking garage. The garage’s structure and floors are cast-in-place reinforced concrete. It consists of primary members ranging from 18”-30” deep, secondary members roughly 12” deep, and one way slabs. (Figures 4.3.2.2 & 4.2.3.3) The 20’ bays and sloping floor slabs offer street level access to each of its four parking levels. The east edge of the garage is flush with the street level, while the western point is approximately 40’ in elevation. While the structural spacing offers some workable

dimensions for interior spaces, the sloped floor slabs and low head clearance (6’8 in some areas) will require careful consideration during the site intervention process.



Figure 4.2.3.4\_Site visibility and contextual relationships



Figure 4.3.1\_Conceptual rendering of spatial relationships

### 4.3\_Programmatic Strategy

The programming of spaces should serve as guidelines for the size and function of designed spaces, as well as their proximity, relationships, and accessibility to each other, the exterior, and the greater urban context. With the intention of this thesis to engage the culture of Seattle on an individual, social, and professional level, the urban craft and cultural center will encompass three broad levels of function. On the individual level (these levels refer to capacities, not necessarily floors), the center will offer opportunity for education, engagement, and patronage of the craftsman model for making and repairing. This includes community workshop spaces, classrooms, a publication/ resource library and retail space, and digital resource spaces. On the social level, the center will offer a gallery space, a culinary venue, and a craft and fine art market space. On the professional level, the center will house a professional design studio, artist studios, a lecture space, and an exhibition space.

The success of this thesis project's fostering cultural paradigm shifts relies heavily on the programmatic and spatial relationships developed between these three types of engagement. Subsequently, the program adjacencies, circulation, and shared support spaces must have special consideration in regards to how interaction and community is developed within the facility. (Figures 4.3.1 & 4.3.2)

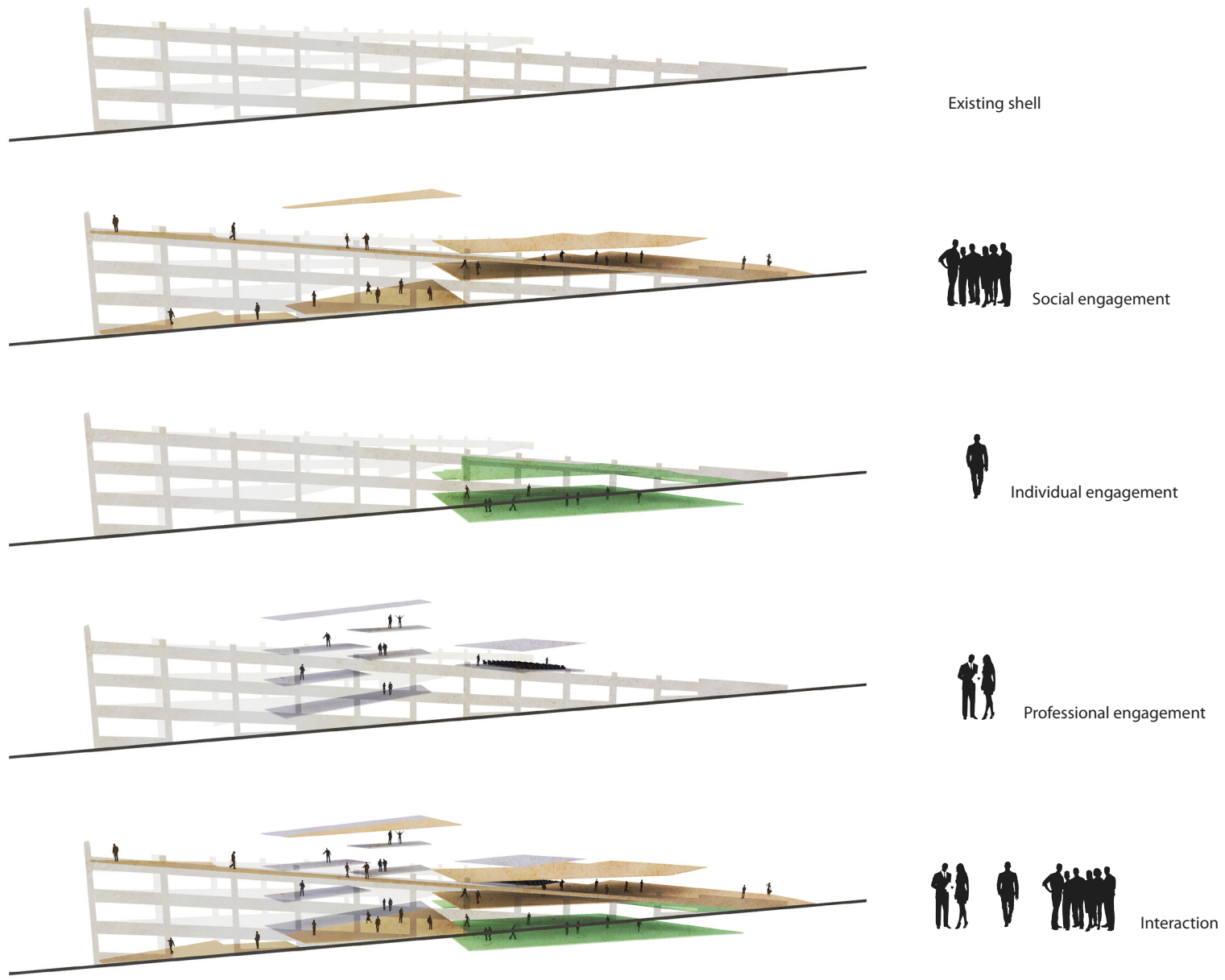





Figure 4.3.2\_Conceptual diagram of program interaction

#### 4.4\_Individual Programmed Spaces and Approximate Square Footages

	Space Name	Size (sf)	Quantity	Cumulative size (sf)	% of total
 Individual	Community Workshop	5,000	1	5,000	
	General Workspace	1,000	1	1,000	
	General Material / Tool storage	1,000	1	1,000	
	Flexible Workroom	800	2	1,600	
	Classroom	800	2	1,600	
	Digital Lab	800	1	800	
	Publication / Resource Library	500	1	500	
					<b>11,000</b>
 Social	Culinary Venue	3,000	1	3,000	
	Food Prep / Storage	1,000	1	1,000	
	Gallery space	1,500	1	1,500	
	Exhibition Space	1,000	1	1,000	
					<b>6,500</b>
 Professional	Lecture / Performance Space	2,000	1	2,000	
	Professional Studio / Office Space	5,000	1	5,000	
	Studio Support Spaces	1,800	1	1,800	
	Shared Artist Studio	2,000	2	4,000	
					<b>10,800</b>
	Public bathrooms	200	4	800	
	Loading Access	600	1	600	
				<b>1,400</b>	4.7%
	<b>Programmed Total</b>			<b>29,700</b>	
	(+) 15% Support / Circulation			4,455	
	<b>Total approximate square footage</b>			<b>34,155</b>	

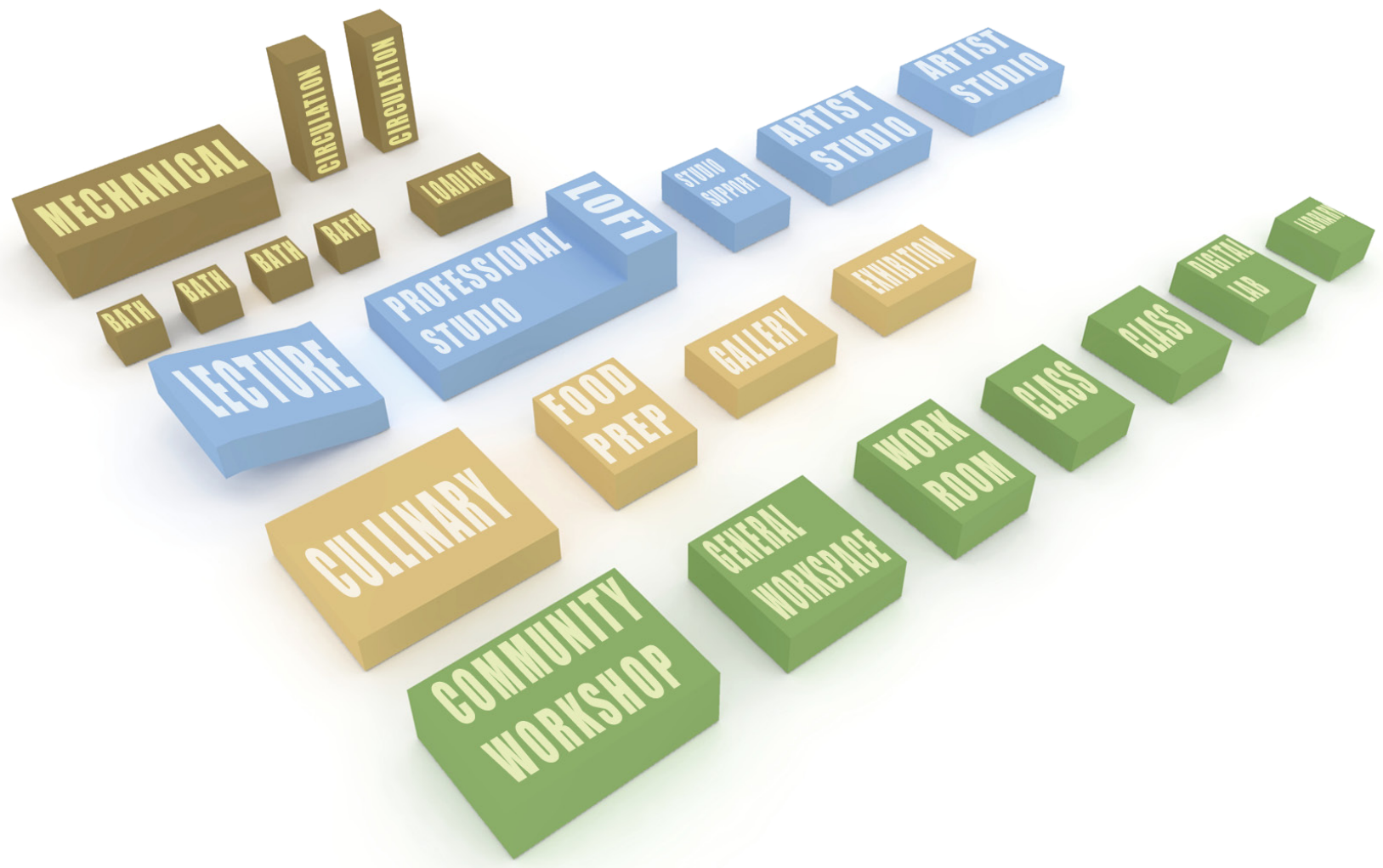


Figure 4.4.1\_Relative sizes of programmed space

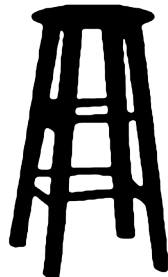
# Chapter 5

## Design

### 5.1\_Design Strategy



Process



Product



Purpose

Before moving into the specifics of design, it is important to briefly outline the connections between architecture and craft in general, and adaptive reuse and craft in particular. In the previous section it was seen that program can provide the framework for cultural engagement and interaction within the context of the worker and user paradigms. In addition to describing planned building functions, however, program is generative in its nature. Perhaps the clearest statement of this is seen within the discipline of architecture. Louis Sullivan wrote in 1896, responding to the apparent departure from precedent as the trumping influence of form, that,

*It is the pervading law of all things organic and inorganic, of all things physical and metaphysical, of all things human and all things super-human, of all true manifestations of the head, of the heart, of the soul, that the life is recognizable in its*

*expression, that form ever follows function. This is the law.*<sup>[21]</sup>

If the disseminating of craft value should influence the strategy and articulation of design, it follows that the architecture of the project should be framed by and respond to the intrinsic aspects of making: process, product, and purpose.

The limits of adaptive reuse augment this narrative of the physical building as an expression of craft. All architecture must reckon on some level with the reality of context. When context includes an existing structure, the opportunity exists to explicitly display the relationship between old and new. Moreover, when one considers the old as an object to be manipulated, there emerges a relationship between material and design. No furniture maker would take a

21. Sullivan, Louis. "The Tall Office Building Artistically Considered". Lippincott's Magazine. March 1896.

well-figured plank of walnut, build a table, and paint it blue. (Figure 5.1.1) Rather the form of the final piece is tested and celebrated by the nature of its material. Likewise, when designing for the reuse of an existing structure, the resulting building should be tested and celebrated in how it responds to what came before. (Figure 5.1.2)



**Figure 5.1.1\_Walnut plank**  
The chalk marks note the mapping of table components



**Figure 5.1.2\_ 'Sunken Ship Parking Garage**  
Existing structure viewed from pioneer square



## 5.2\_Design Process

The early stages of the design process began with an expression of the integration of old and new (Figure 5.2.1). This exercise sought to clarify how the materiality and the spatial character of the existing parking structure might be acknowledged and enhanced through intervention. Following this departure, a massing study was done to explore how intervention might respect and respond to the iconic volume of the 'sinking ship'. The intention of this section is to describe how the design strategy informed the conceptual beginnings of the project, and how the physical intervention of structure and space would occur.

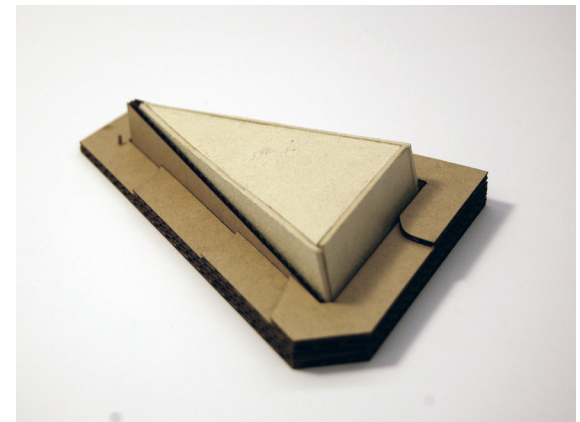
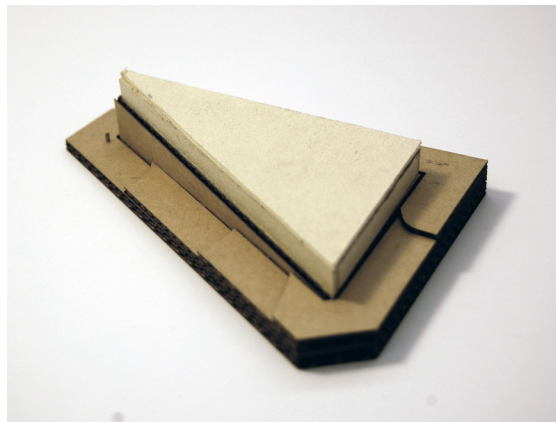
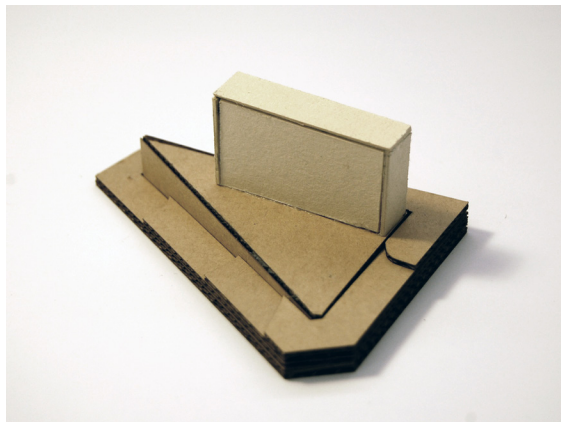
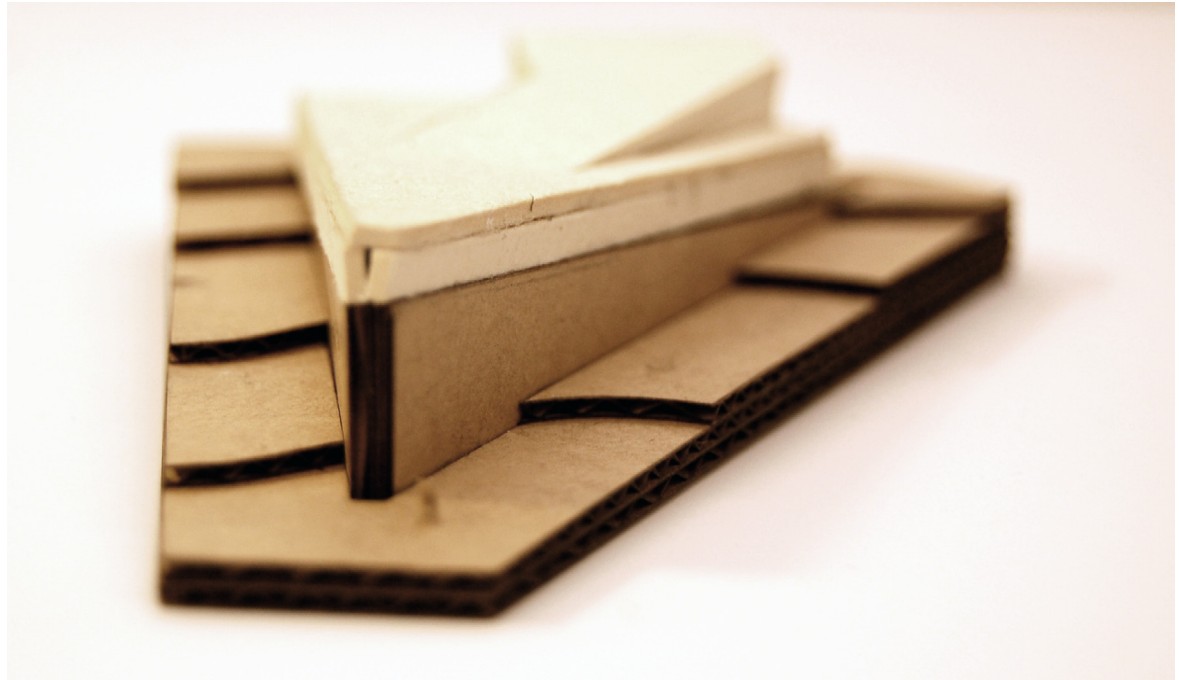
Figure 5.2.1\_Conceptual beginnings

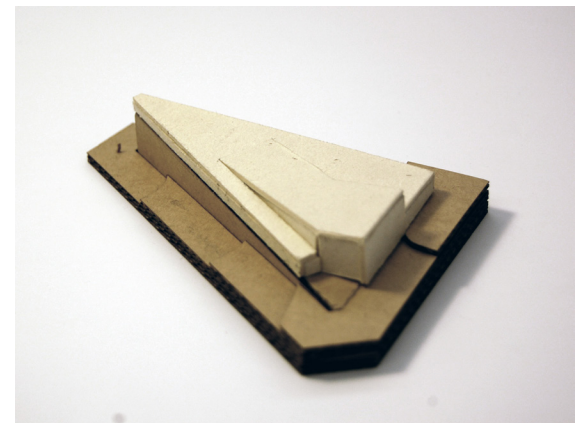
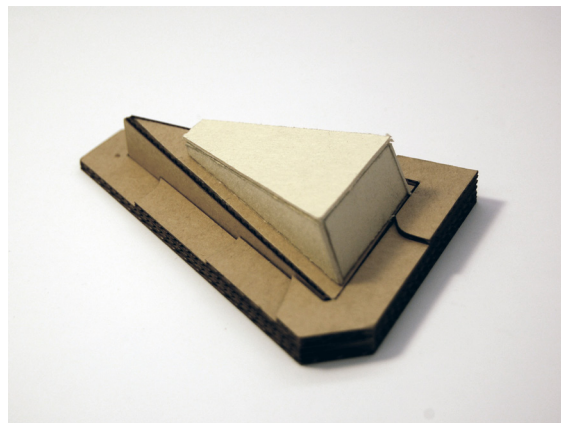
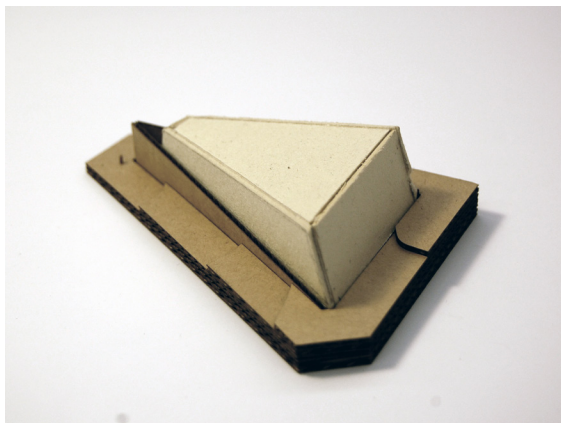
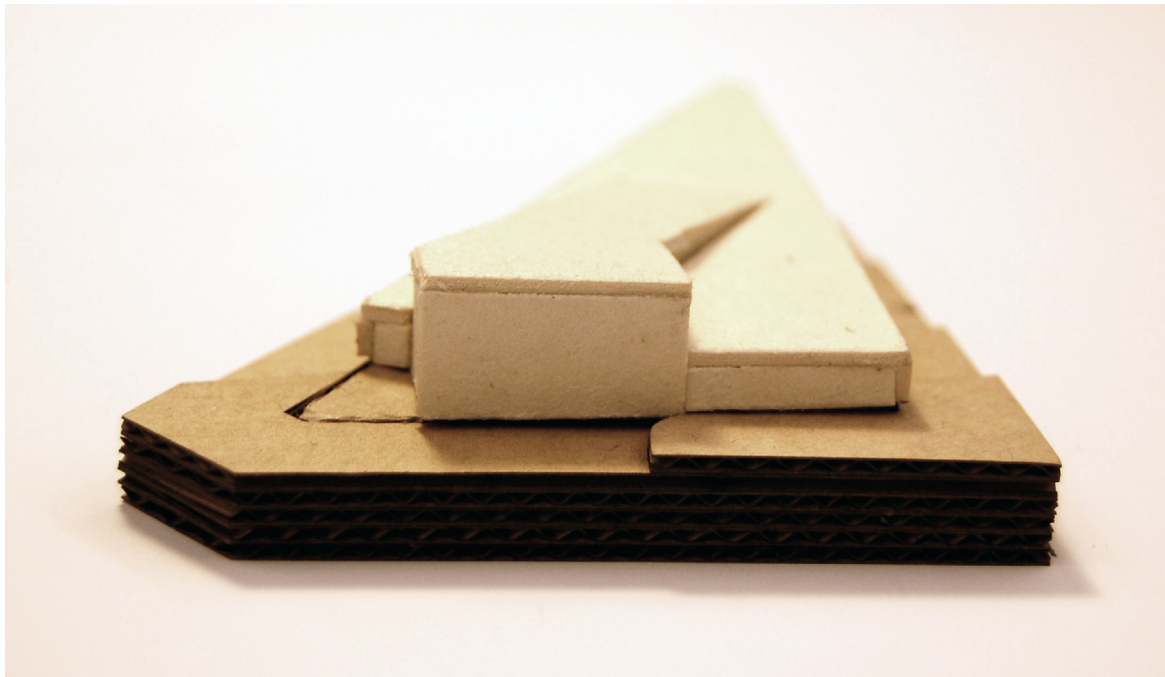


**Figure 5.2.2\_Massing studies**

(bottom of spread) Massing model progression left to right  
(top this page) Massing from west  
(top opposite page) Massing from east

This study develops an understanding of how the massing of a new intervention might respect and interact with the existing form. The final iteration is a solution in which a new structure emerges from the old. From the western point, the addition is out of view, and the existing mass of the sinking ship is preserved. From the eastern edge, the new mass is apparent and the relationship between old and new is understood.





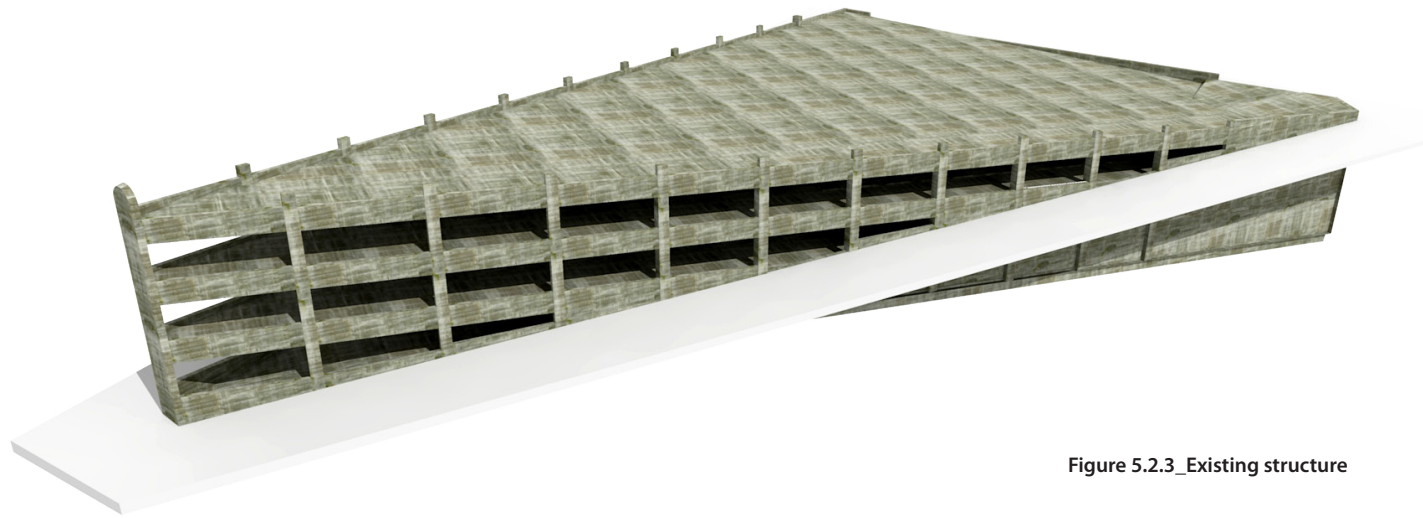


Figure 5.2.3\_Existing structure

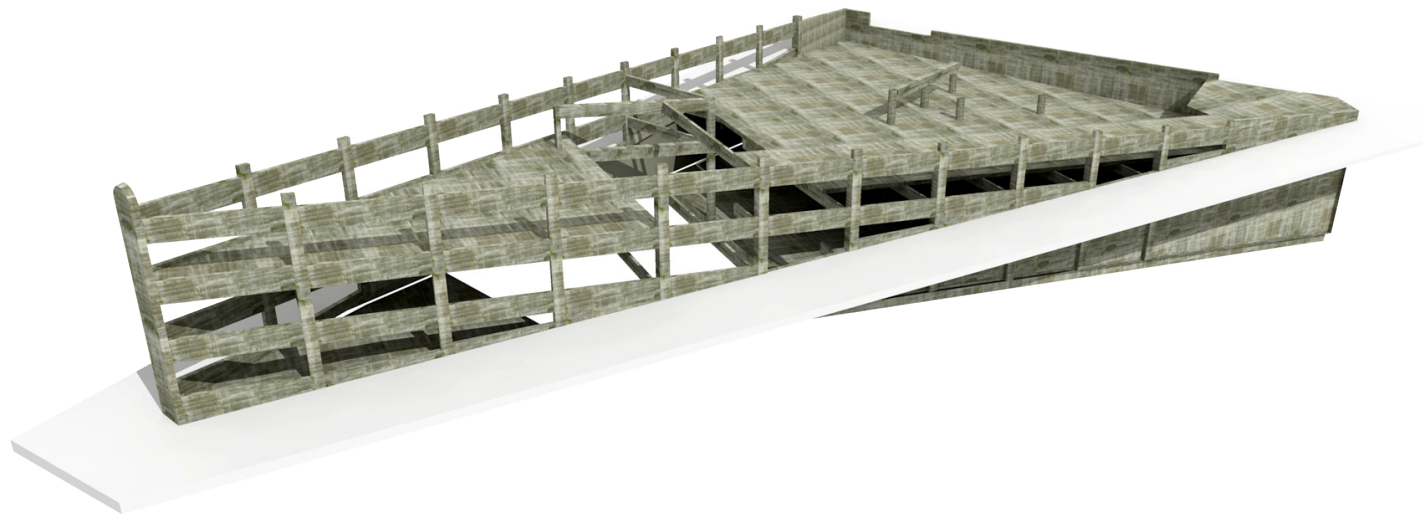


Figure 5.2.4\_Existing structure to remain

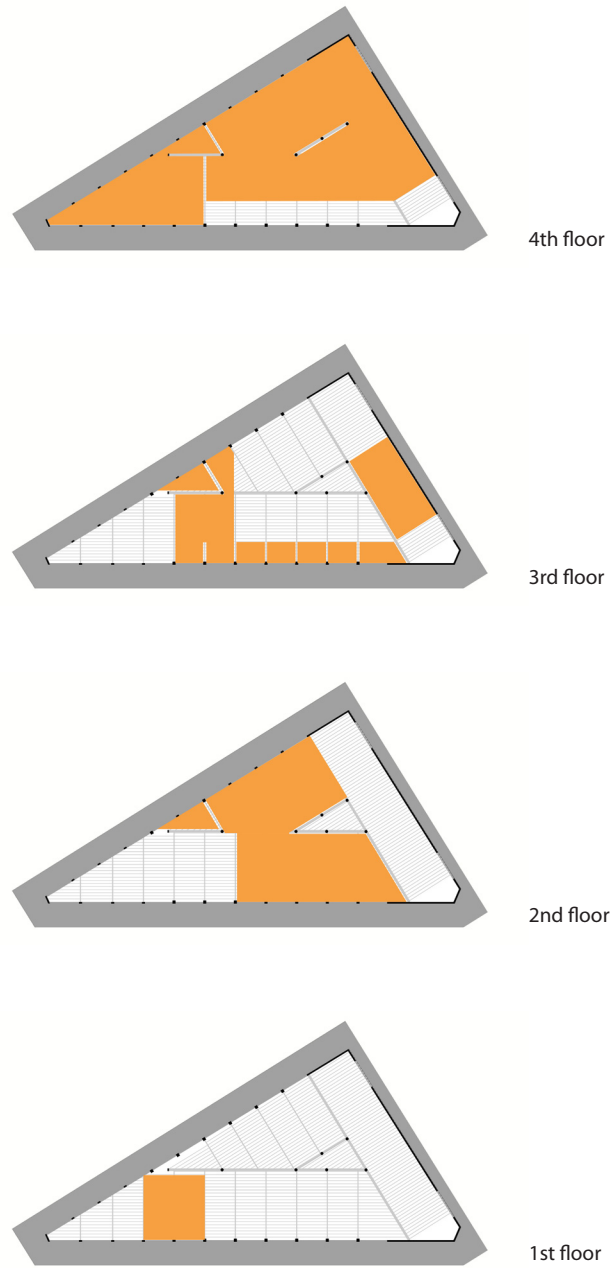


Figure 5.2.5\_ Removed Structure Diagram



Figure 5.2.6\_ Saw cutting and removal of structure



Figure 5.2.7\_ Shoring of existing structure to remain

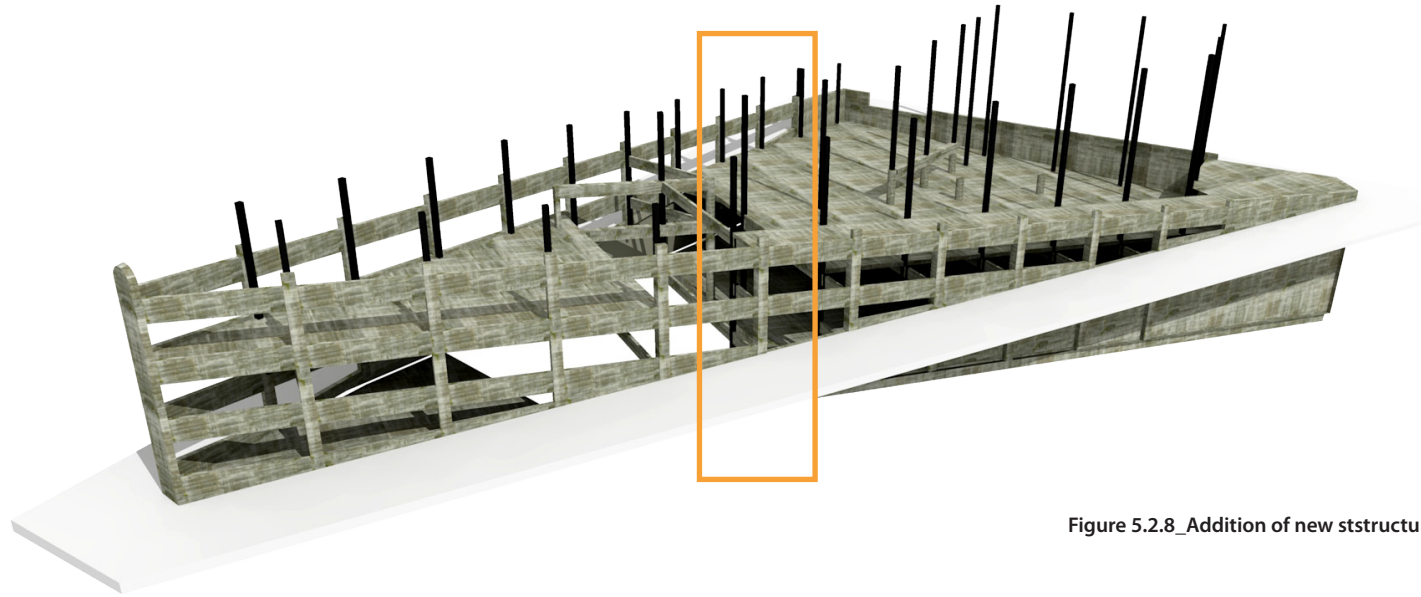


Figure 5.2.8\_Addition of new ststructural members

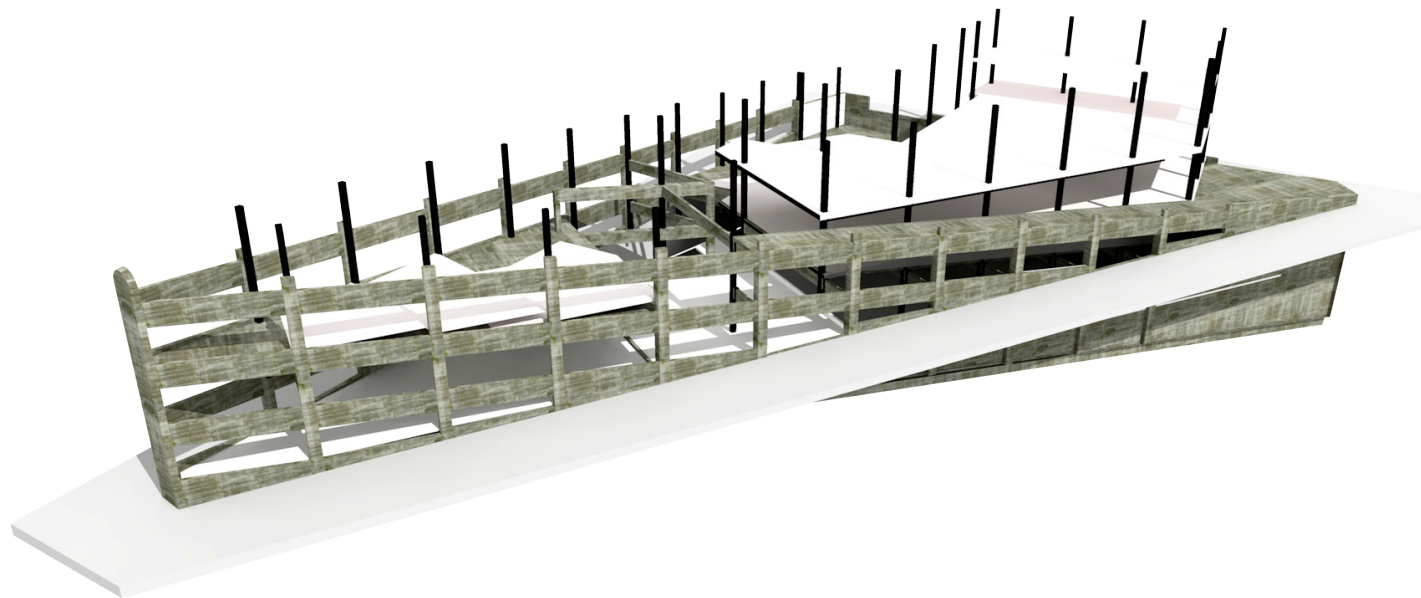
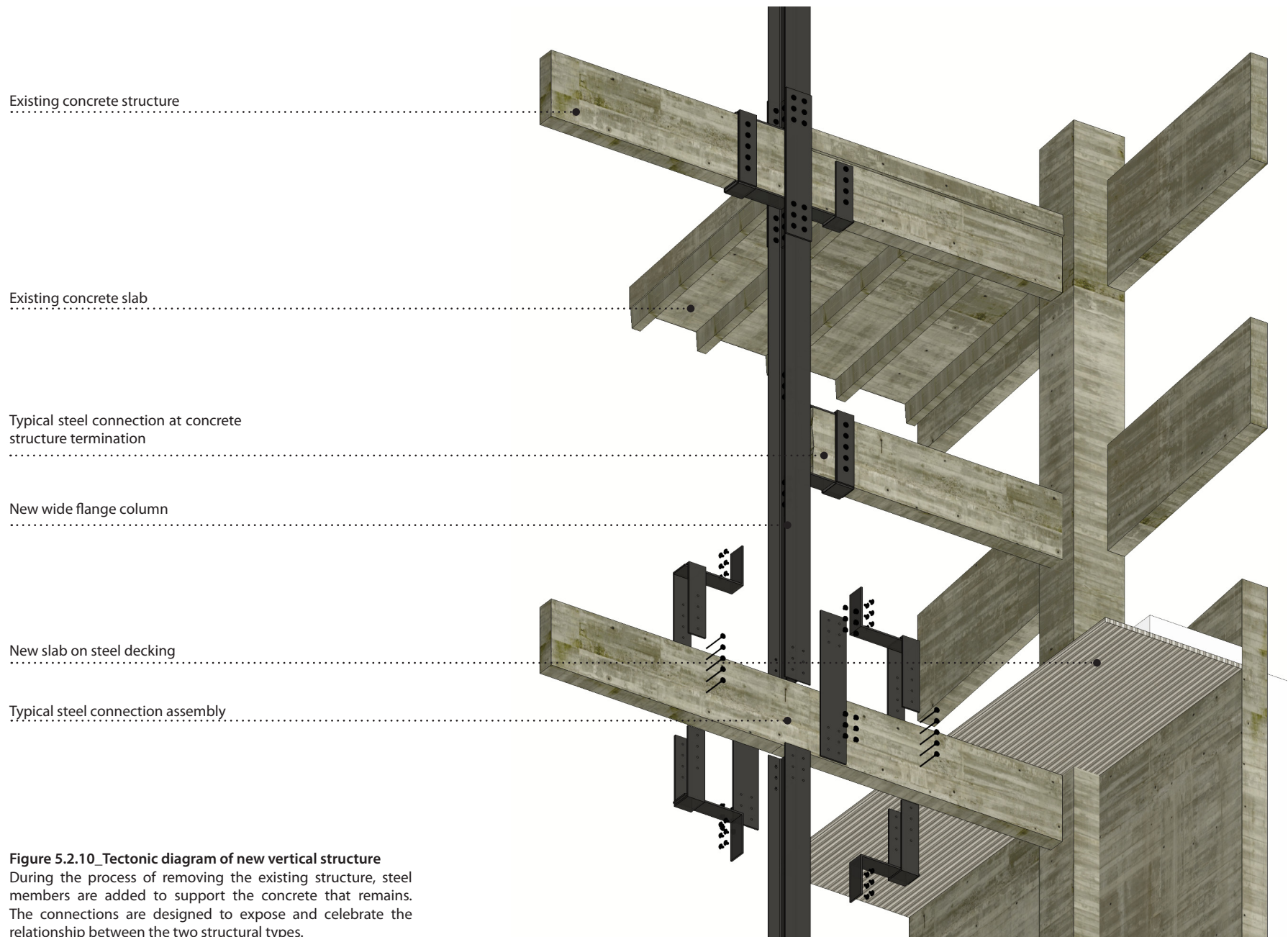


Figure 5.2.9\_Addition of new floor slabs



**Figure 5.2.10\_ Tectonic diagram of new vertical structure**

During the process of removing the existing structure, steel members are added to support the concrete that remains. The connections are designed to expose and celebrate the relationship between the two structural types.

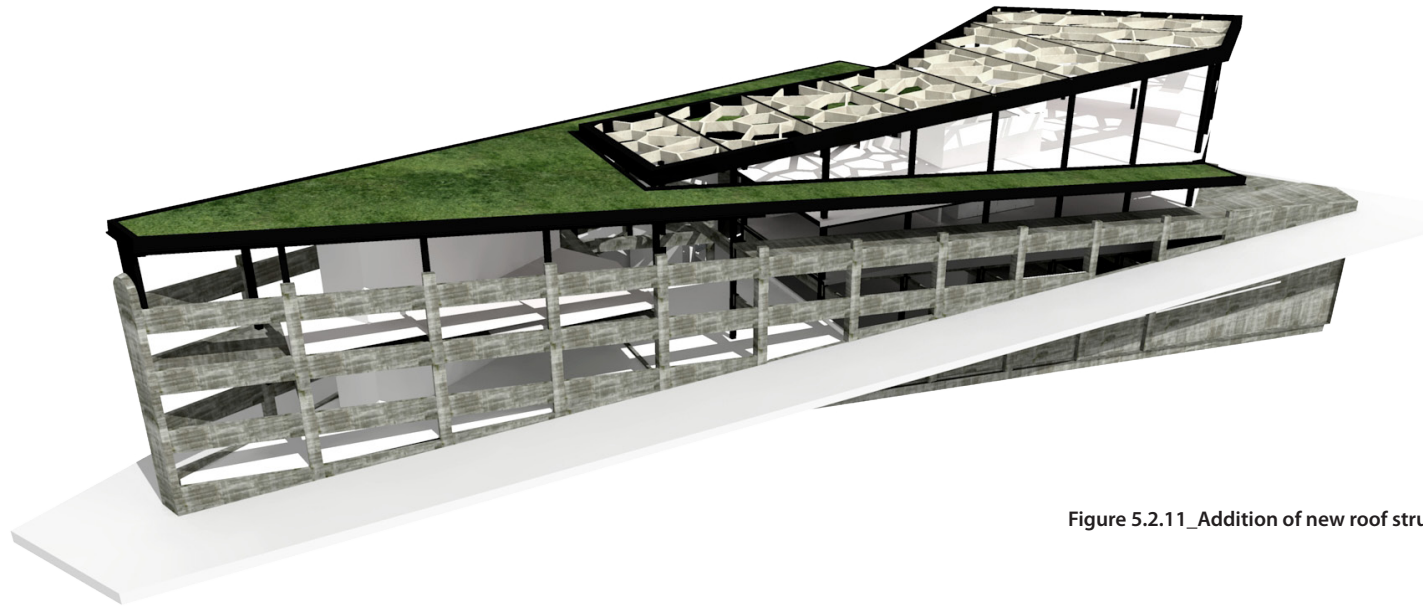


Figure 5.2.11\_Addition of new roof structure

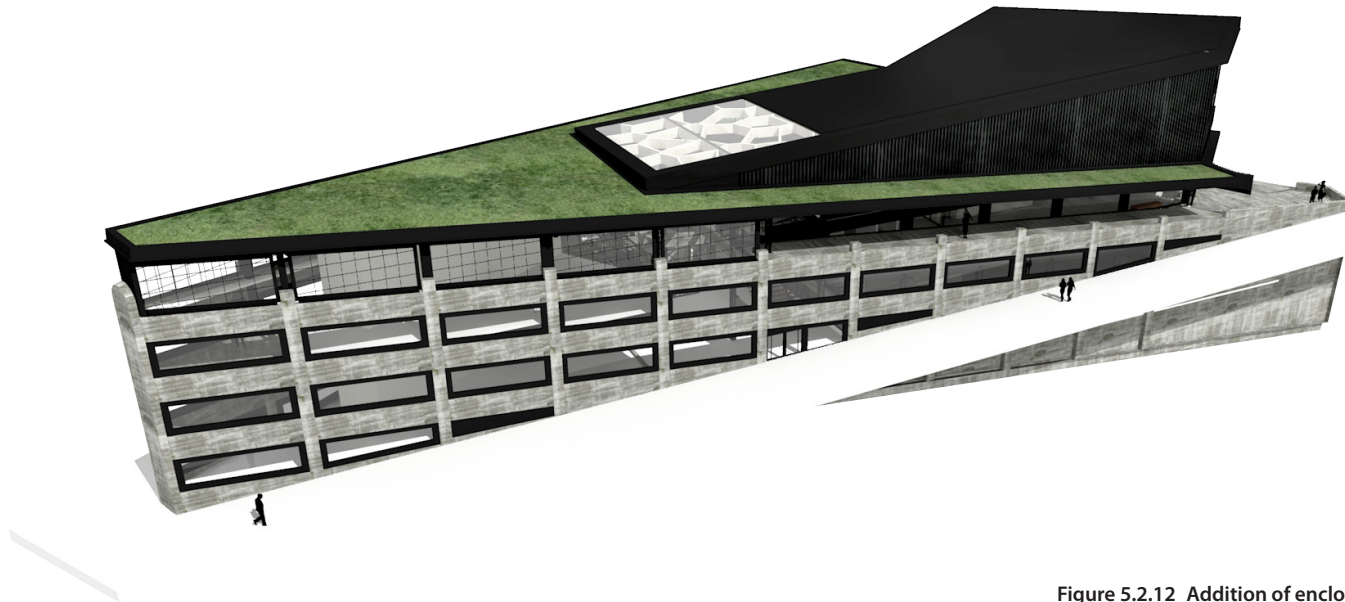
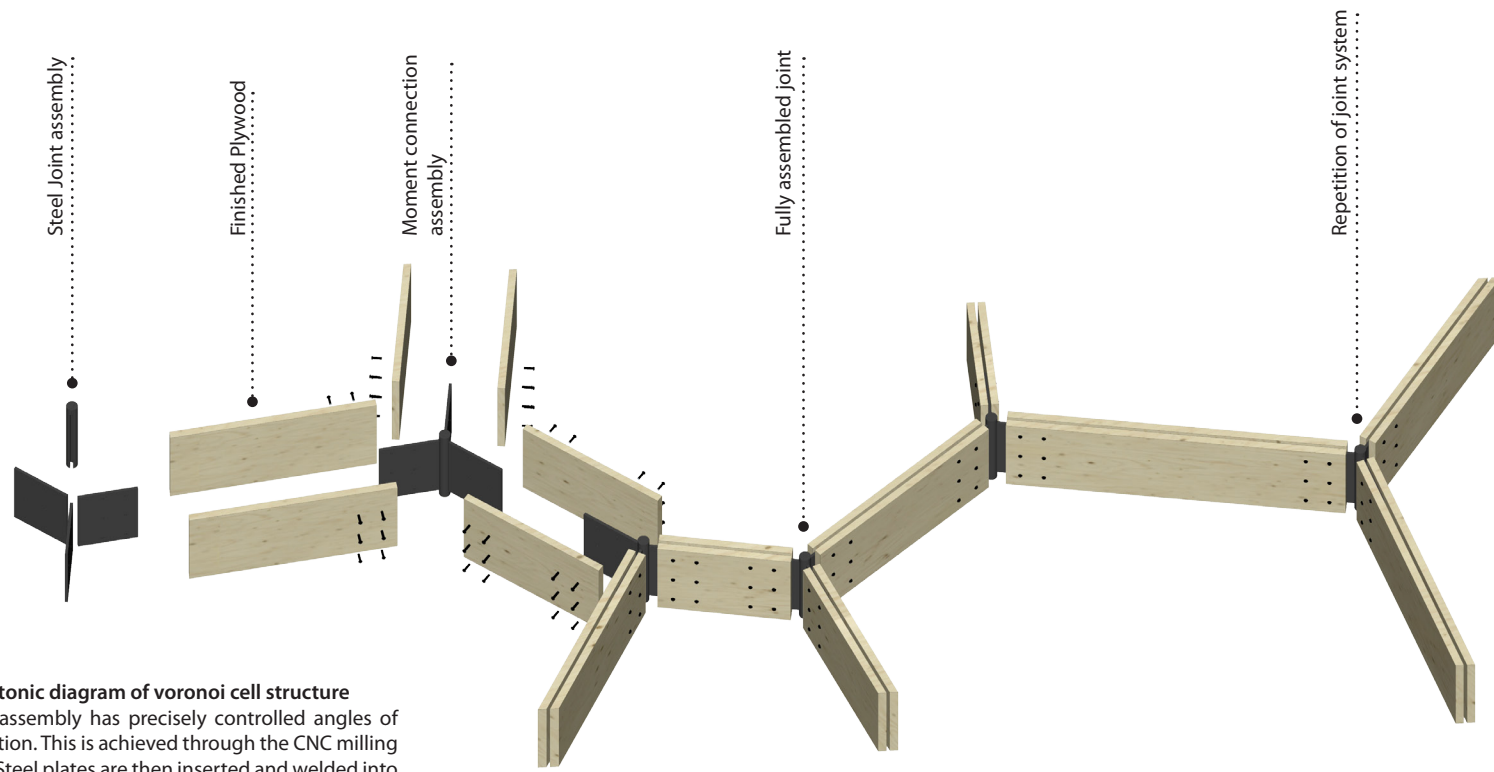
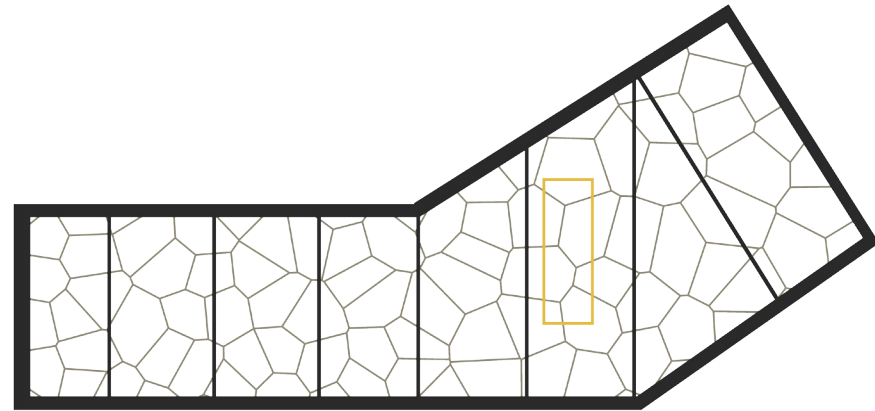


Figure 5.2.12\_Addition of enclosure

**Figure 5.2.13\_Diagram of voronoi cell roof structure**

The roof structure of the new massing is meant to clarify the distinction between old and new. It was developed parametrically in Grasshopper, and expresses the possibilities of digital fabrication's role within the contemporary notion of craft.



**Figure 5.2.14\_Tectonic diagram of voronoi cell structure**

Each joint in the assembly has precisely controlled angles of structural intersection. This is achieved through the CNC milling of steel bar stock. Steel plates are then inserted and welded into the resulting grooves in order to accept the spanning plywood members.

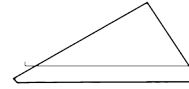
### 5.3\_Design Product



This section describes the product of design, in which the specific programmatic articulations and adjacencies are displayed. In addition, how they are integrated with the old and new massing and structure is shown. It should be noted here that the product, process, purpose, framework is limited by its linear nature. In reality, both the general subject of craft, and the particular subject of architectural design require a fluidity between the three that is difficult to express. The relevance of this truth in regards to the discussion of product should be considered by the reader. Plans, sections, and elevations, describe not only the result of process, but also begin to reveal the intent of purpose. For example, the openness of the main spaces implies flexibility. (Figures 5.3.6-5.3.9) By emphasizing the programmatic *structure* of social, individual, and professional engagement, the specific activities which best describe these explorations into craft are able to evolve. If the workshop need to one day become a digital fabrication lab, the open volume is able to adapt.

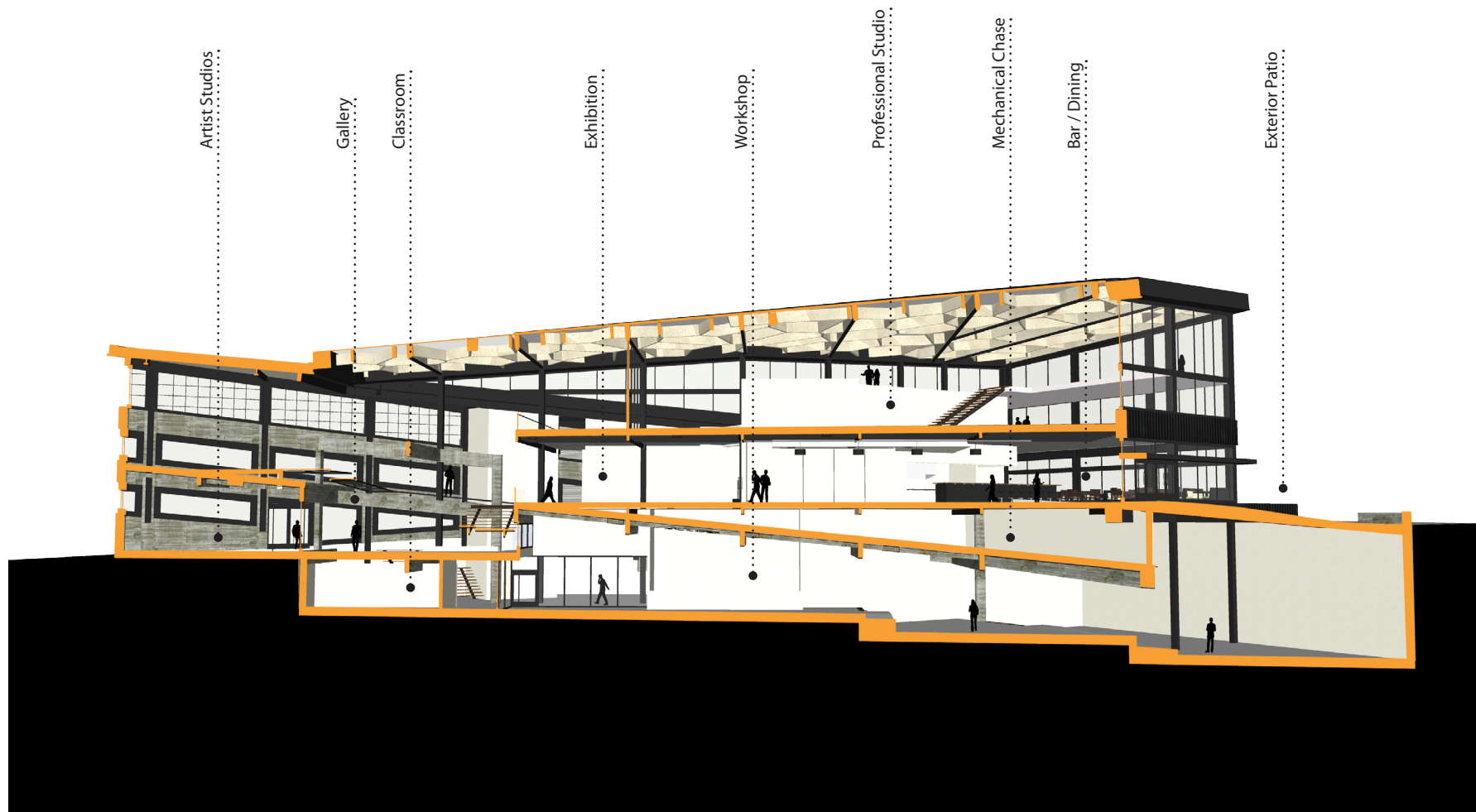


Figure 5.3.1\_Birds eye view looking south



**Figure 5.3.2 Section perspective**

The longitudinal section through the building reveals the programmatic relationships, and how they are situated within the old massing and structure.



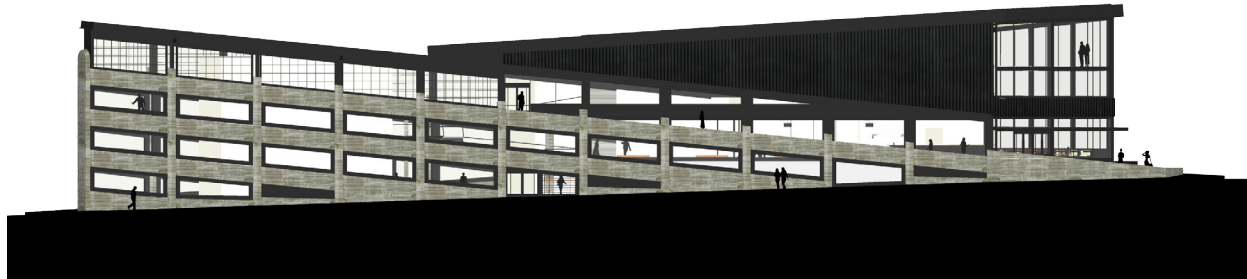


Figure 5.3.3\_South elevation

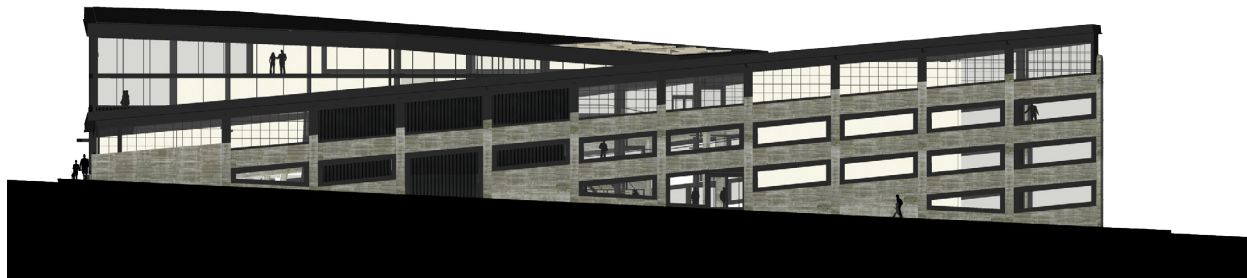


Figure 5.3.4\_North elevation



Figure 5.3.5\_East elevation

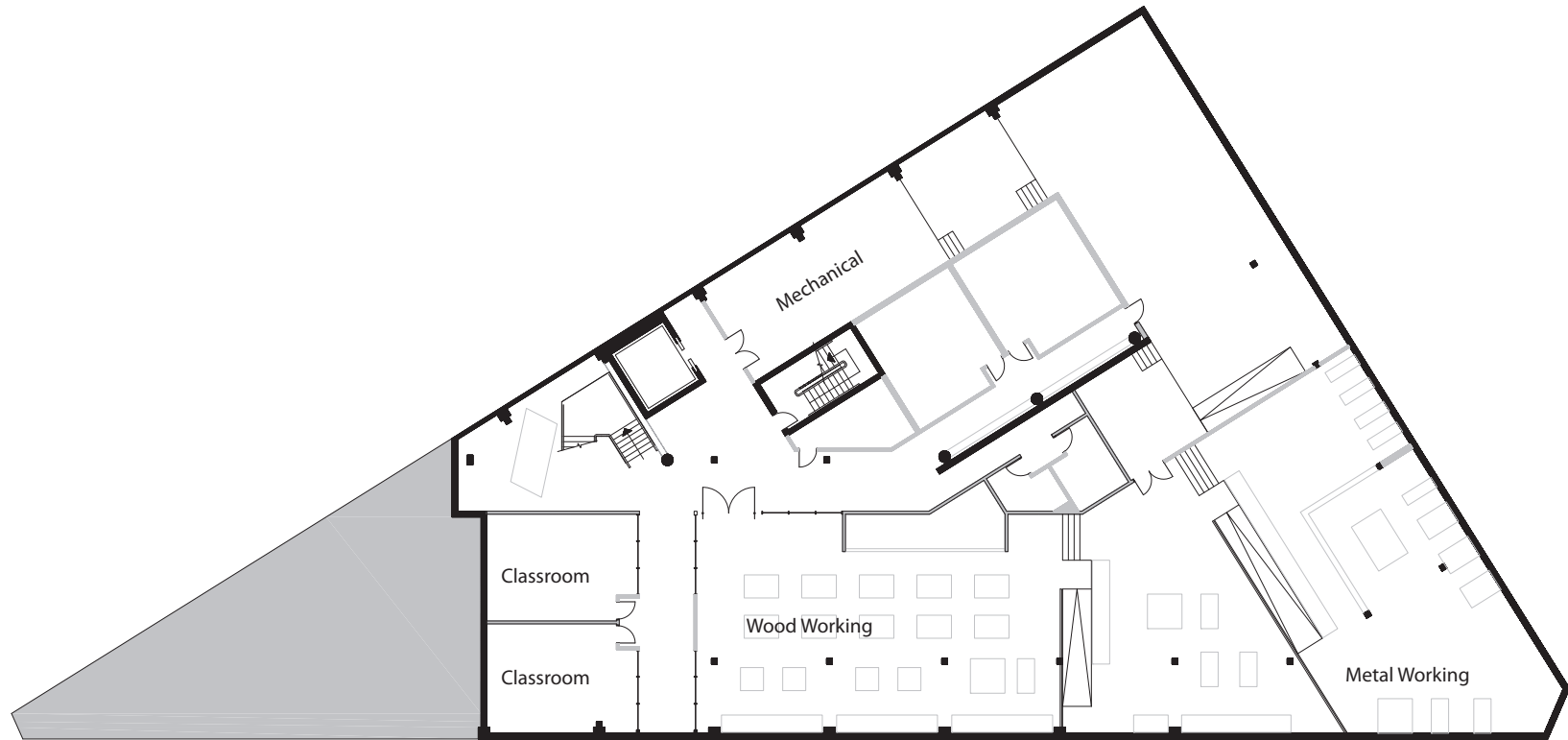
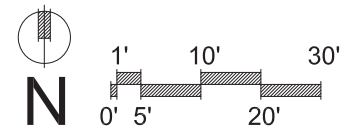


Figure 5.3.6\_Lower level floor plan



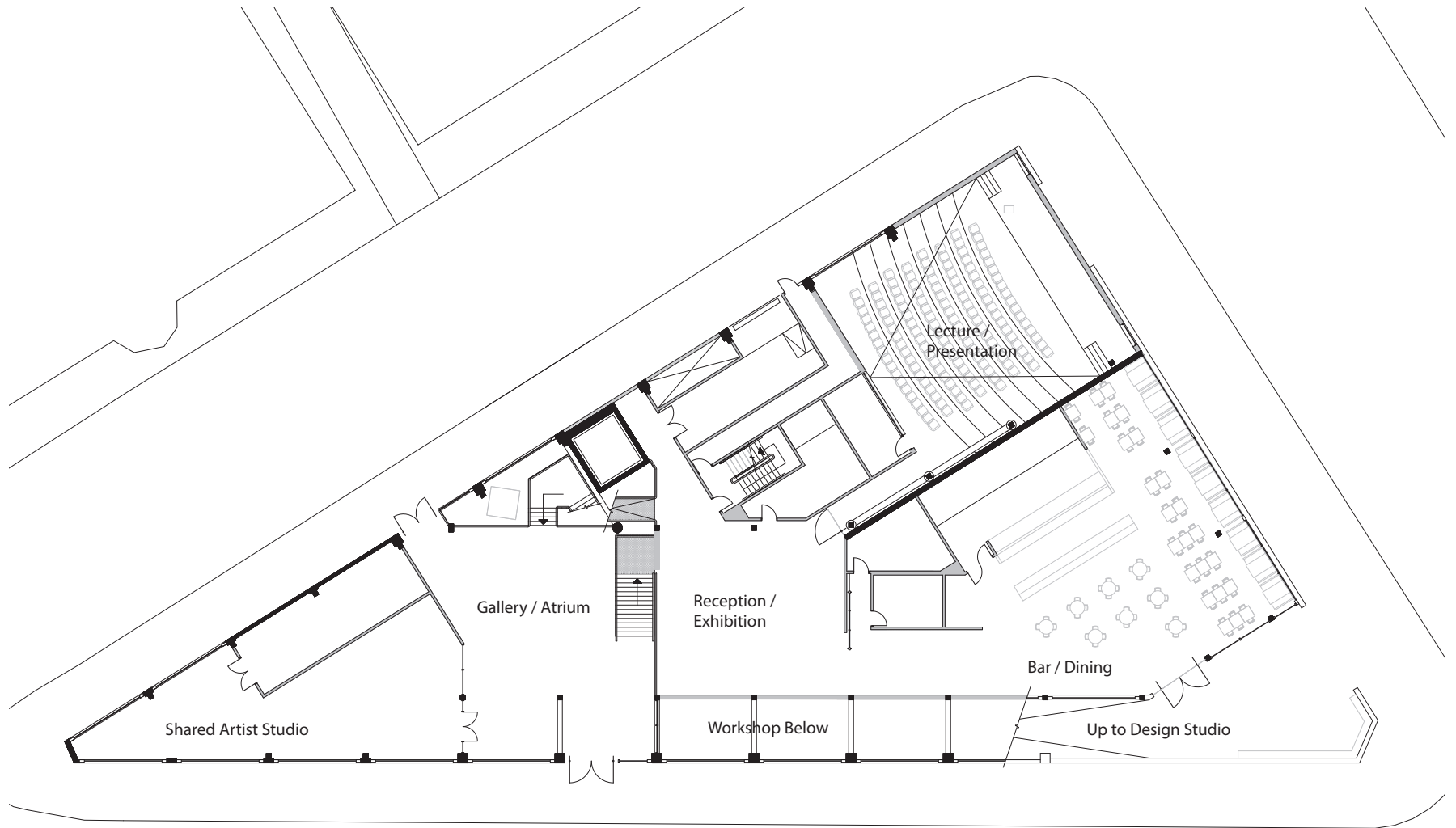


Figure 5.3.7\_Ground floor plan

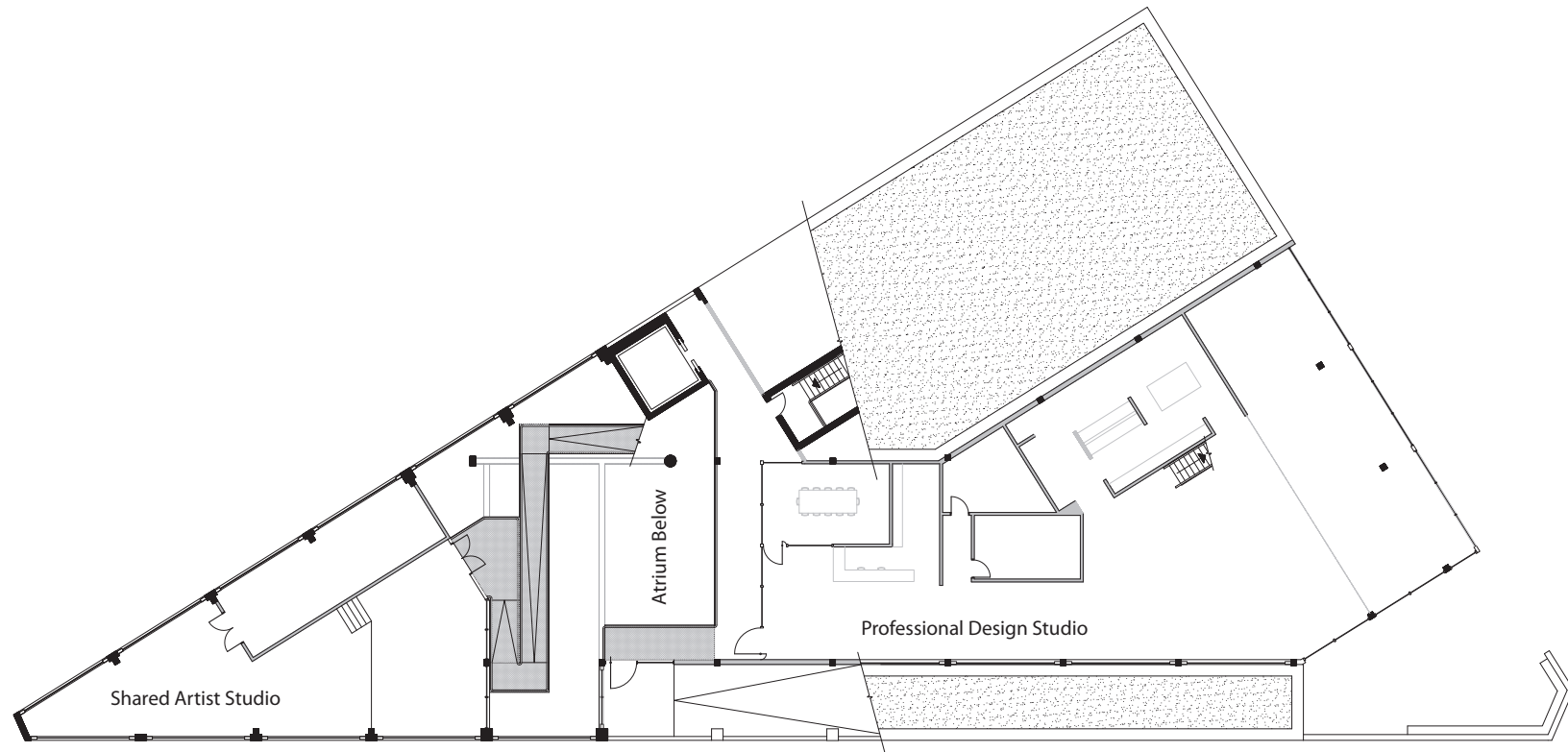
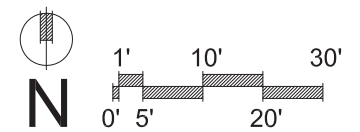


Figure 5.3.8\_Upper level floor plan



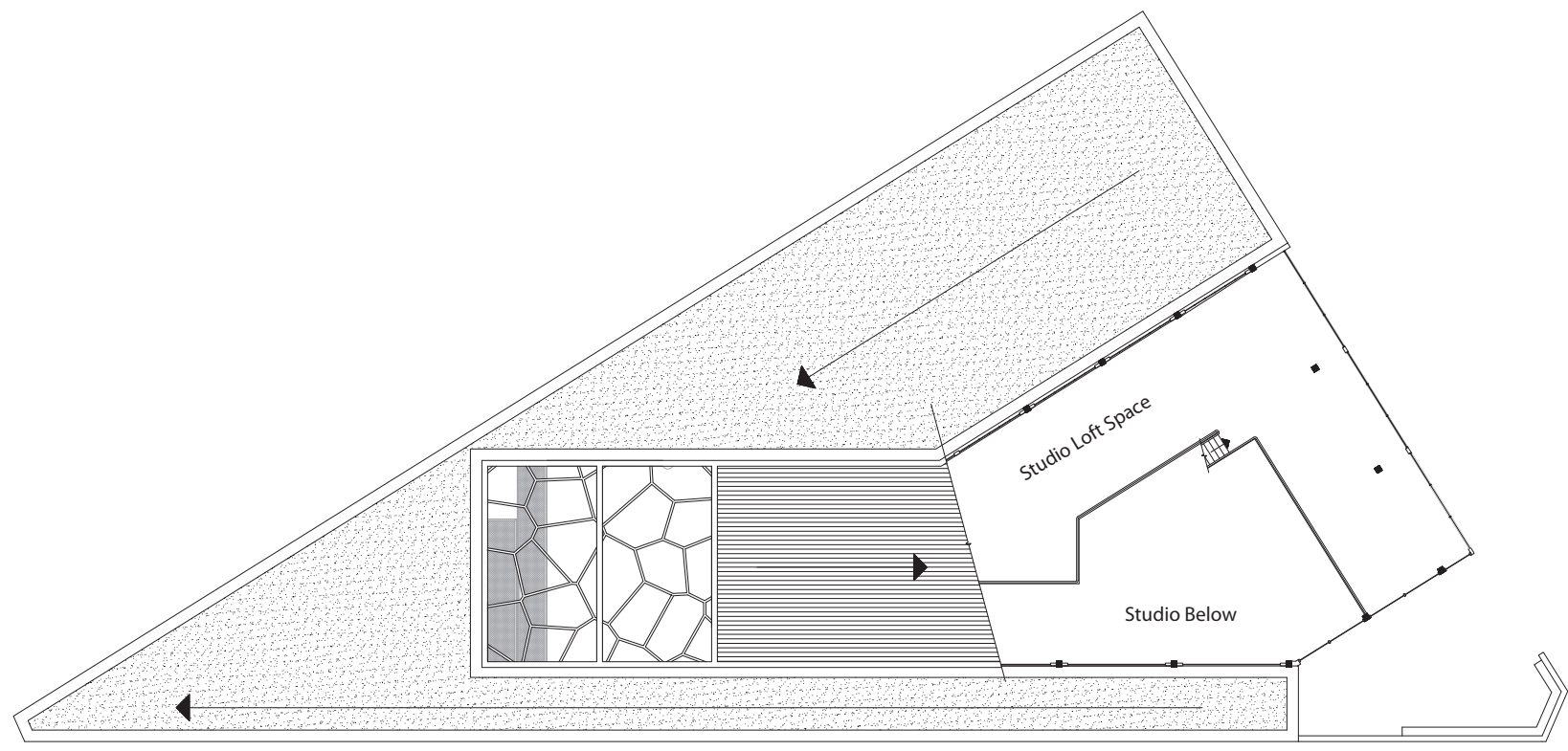


Figure 5.3.9\_Roof and loft level plan



#### 5.4\_Design Purpose

Perceiving the purpose of design depends upon the observer's ability to understand and empathize with the experience of space. The following section selects key moments throughout the building to express these experiences, and highlight how the design of the project responds to the issues addressed in this thesis.

The most basic of these matters is that the adaptive reuse of the site would activate it as an urban asset. This role is fulfilled through the physical and programmatic advocacy towards a discovery of craft and its values. Physically, the dialog between old and new establishes a connection between history and craft, and encourages users to consider the permanence of built objects. Spatially, the adjacencies and visual linkages allow for unintentional interactions and the organic development of community. Programmatically, the center provides the necessary framework to stimulate interest in craft, and demonstrate the values of making.

**Figure 5.4.1\_Perspective from Pioneer Square at dusk**  
The activation of the site is perceived through the existing mass acting as a lantern in the historic district.



**Figure 5.4.2\_Perspective of workshop interior**

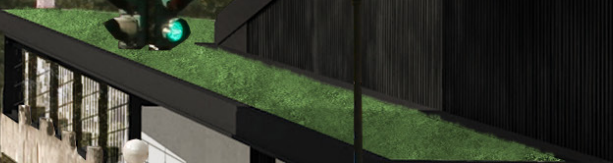
The individual engagement of the program occurs in a space where links to the street level are perceived through a lightwell formed by the removal of existing structure.



**Figure 5.4.3\_Perspective from Yesler and 2nd**

The social engagement of the program begins with the main entrance leading to the bar and dining area. This prominent corner of the building will act as the hub for activities extending into the evening hours.





ONE WAY

2nd Ave East  
2nd Ave

CLUB PARTNERS  
206.622.5500



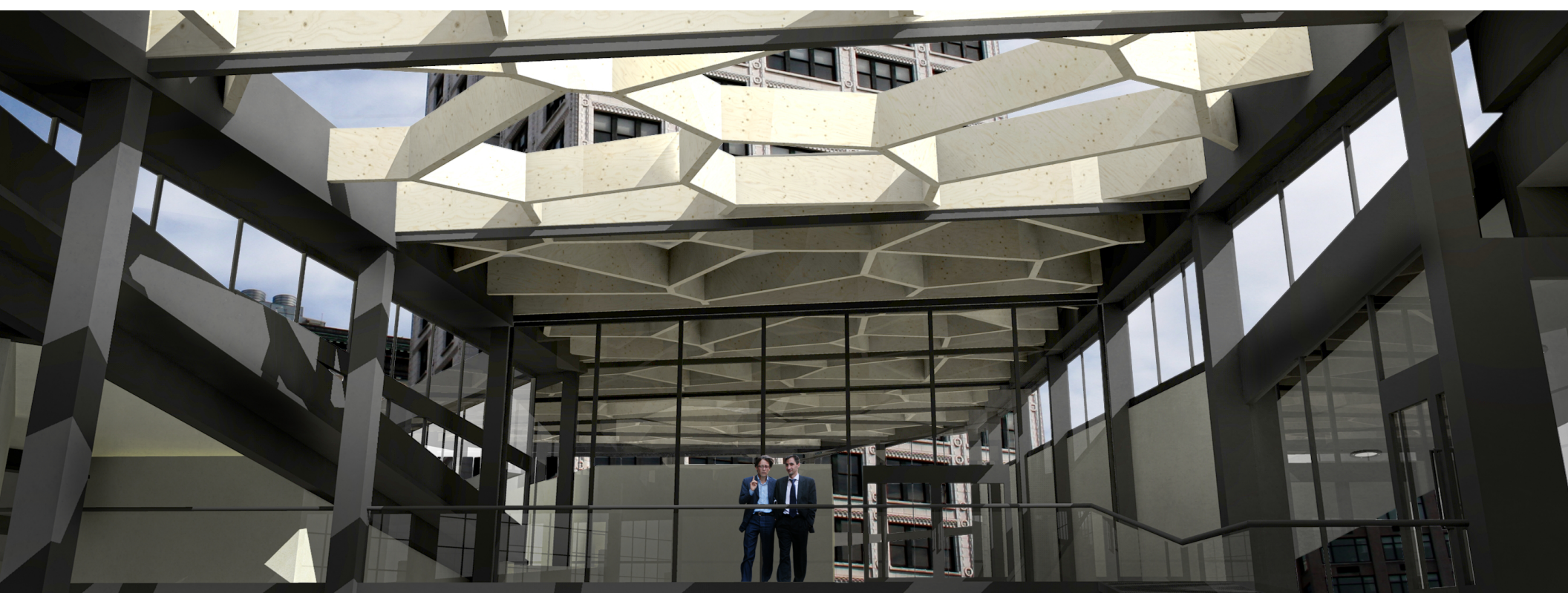
**Figure 5.4.4\_Perspective of auditorium space**

The auditorium serves as the primary means for professionals to engage the city. The stepping of the space follows the existing sloped slab. The entrance is marked by the junction of old and new structure, which is highlighted by a daylit light well.



**Figure 5.4.5\_Perspective of voronoi cell roof**

The professional design studio is marked by the most forward thinking aspect of the intervention: the voronoi cell roof structure. At it's termination over the atrium, even the pinnacle of new leaves room for the acknowledgement of what came before.





**Figure 5.4.6\_Perspective towards exhibition space**

In addition to the integration of old and new structure, the intervention displays the relationships between old and new experiences. The exterior ramp to the professional studio is paralleled by the new interior corridor linking the restaurant and exhibition space.



**Figure 5.4.7\_Perspective of main atrium gallery space**

The atrium gallery marks the clearest point where the programmatic engagements interact. There are visual and physical links ranging from the workshop below, to the professional studios above. The space celebrates the old concrete structure through its display of new structural connections, and the weaving of circulation through its spanning members.





## Chapter 6

### Findings

This thesis began with the notion that the role of cultivator is at the core of mankind's identity, and that the values found in the act of making affirm this role. Through the identification of the qualitative, philosophical, and self-edifying worth found in the maker-as-craftsman approach, a framework for deep and validating engagement was shown. The problems that were addressed developed from the diminishing of these values in the economies and culture of contemporary society. Specifically, this was shown through the compartmentalization of process, the reduced durability and utility of products, and the consumer's resulting impairment and ignorance. In response, the adaptive reuse of a parking garage into a craft and cultural center was undertaken. The intention of this response was to explore a means by which the values of the tradition of making might be defined

and communicated to a contemporary urban context.

As in any built object, architecture has the ability to express craft. Programmatically, architecture provides a shell to house and inform activity. The resulting design used these notions to generate a place where people might learn to engage deeply in contemplation, comprehension, and action. That is, that the act of making might encourage a departure from the cyclical trappings of consumerism.

Throughout the various stages of developing and defending this thesis, it has become clear that *craft* as a subject is broad in its scope. This is perhaps affirming of the notion that its place in contemporary society is undefined. The conclusions and successive design project contained herein cannot comprehensively address the nuances of the matter, however



Figure 6.1\_Final thesis defense

the narrative of the tradition of making and the lost values of the craftsman has proven to be compelling. This is particularly clear in regards to the reviewers' response to a building as a crafted object, and its program as an educator of culture.

The question, then, is how does program educate? How does architecture teach? This thesis has offered a theoretical response, and is perhaps limited to such by its nature. What lies within that response, however, is a belief in incremental change. That engagement by and through architecture must happen on multiple levels, because it has no way of knowing who is listening. It is here where the ramblings of theory and the pragmatism of reality have the best chance of meeting: that craft's greatest hope for influencing society, is in teaching one maker at a time.



## Bibliography:

- "100 years of automobile history." *Automotive production volume statistics*. N.p., n.d. Web. 17 Sept. 2011. <[www.carhistory4u.com/the-last-100-years/car-production](http://www.carhistory4u.com/the-last-100-years/car-production)>.
- Arendt, Hannah. *The human condition*. Chicago: University Of Chicago Press, 1958. Print.
- Bronowski, Jacob. *The ascent of man*. [1st American ed. Boston: Little, Brown, 1974. Print.
- "Chicago Park District." *Chicago Park District: Welcome*. N.p., n.d. Web. 17 Sept. 2011. <[http://www.chicagoparkdistrict.com/index.cfm/fuseaction/parks.detail/object\\_id/6e5fec8b-4e9a-400a-b175-82f9fd1ea811.cfm](http://www.chicagoparkdistrict.com/index.cfm/fuseaction/parks.detail/object_id/6e5fec8b-4e9a-400a-b175-82f9fd1ea811.cfm)>.
- Crawford, Matthew B.. *Shop class as soulcraft: an inquiry into the value of work*. London: Penguin Books, 2010. Print.
- Frey, William H., and Cheryl L. First. *Investigating change in American society: exploring social trends with US census data and StudentChip*. IBM version. ed. Belmont: Wadsworth Pub. Co., 1997. Print.
- Gilbreth, Frank Bunker. *Motion study, a method for increasing the efficiency of the workman With an introd. by Robert Thurston Kent..* Bury St. Edmunds, Suffolk: Constable, 1911. Print.
- Jacobs, Jane. *Death and Life of Great American Cities*. New York: Random House. 1961. Print.
- Knowledge for development world development report : 1998/99*. London: Oxford University Press, 1999. Print.
- Miller, Jessica. *RepairLab : empowering a culture of adaptive reuse in Pioneer Square's sinking ship*. M. Arch. Thesis. University of Washington. 2009.
- Pioneer Square 2015: A Strategy for Seattle's Oldest Neighborhood*. Pioneer Square Revitalization Committee, June 2010. Pioneer Square Guidelines. Pioneer Square Preservation Board. Department of Neighborhoods. 1999.
- Seattle Municipal Code. Title 23 - LAND USE CODE, Subtitle III Land Use Regulations; Division 3 Overlay Districts; Chapter 23.66 - Special Review Districts; Subchapter II Pioneer Square Preservation District.
- Sennett, Richard. *The culture of the new capitalism*. New Haven: Yale University Press, 2006. Print.
- Sennett, Richard. *The craftsman*. New Haven: Yale University Press, 2008. Print.
- "Studio O+A." *Studio O+A*. N.p., n.d. Web. 20 Sept. 2011. <<http://www.o-plus-a.com/>>.
- "The Tall Office Building Artistically Considered". Lippincott's Magazine. March 1896.

Taylor, Fredrick Winslow. *The principles of scientific management*. Gloucester, Massachusetts: The Echo Library, 2006. Print.

"Torpedo Factory Art Center." *Torpedo Factory Art Center*. N.p., n.d. Web. 22 Sept. 2011. <<http://www.torpedofactory.org/index.html>>.

Thompson, Lynn. Seattle Times. Pioneer Square: Historic Character Vs. Height. March 9, 2011. Print.