

**Wood Cityscapes
Mass Timber Office Building**

Mariam Hovhannisyan

**A thesis submitted in partial fulfillment of the
requirement for the degree of**

Masters of Architecture

University of Washington

2015

Committee:

Kathrina Simonen

Jim Nicholls

Susan Jones

Giovanni Migliaccio

Program Authorized to Offer Degree:

Architecture

©Copyright 2015
Mariam Hovhannisyan

University of Washington

Abstract

Wood Cityscapes: Mass Timber Office Building

Mariam Hovhannisyan

**Kathrina Simonen Associate Professor
Architecture**

Most office building construction relies on steel and concrete for mid-high rise office building applications. The primary goal of this thesis is to understand the implications of CLT and mass timber construction systems for mid-high rise office buildings in Seattle by developing a prototypical office building located on a specific site. This research thesis will focus on comparing this prototypical mass timber office building design to the same/similar design using industry standard construction materials for Seattle. The criteria for comparison will include code, cost, schedule and greenhouse gas emissions.

TABLE OF CONTENTS

CHAPTER ONE

Introduction.....pg 3

CHAPTER TWO

Literature Review.....pg 9

CHAPTER THREE

Methodology Overview.....pg 17

CHAPTER FOUR

Design.....pg 22
 Site Context.....pg 23
 Code Compliance.....pg 30
 Building Diagrams.....pg 35
 Floor Plans & Sectionspg 40
 Structural Plans.....pg 50
 Experience.....pg 57

CHAPTER FIVE

Costs.....pg 62
 Cost per Assembly.....pg 63
 Summary Cost Comparison.....pg 70
 Costing Sheets.....pg 72
 Bid Analysis.....pg 79
 Take-offs.....pg 84
 Credits.....pg 90

CHAPTER SIX

Schedule.....pg 91
 Schedule Analysis.....pg 92
 Summary Schedule.....pg 94
 Detailed Schedules.....pg 95
 Productivity Analysis.....pg 103
 Credits.....pg 113

CHAPTER SEVEN

Environment.....pg 114
 Analysis Summary.....pg 115
 LCA Results.....pg 118
 Material Quantity Input.....pg 119
 Credits.....pg 123

CHAPTER EIGHT

Conclusion.....pg 124

APPENDIX A.....pg 126

WOOD CITYSCAPES

MASS TIMBER OFFICE BUILDING



Chair: Kathrina Simonen
Co Chairs: Jim Nicholls, Susan Jones, Giovanni Migliaccio

Autumn 2015
Mariam Hovhannisyan

TABLE OF CONTENTS

CHAPTER ONE

Introduction.....pg 3

CHAPTER TWO

Literature Review.....pg 9

CHAPTER THREE

Methodology Overview.....pg 17

CHAPTER FOUR

Design.....pg 22

Site Context.....pg 23

Code Compliance.....pg 30

Building Diagrams.....pg 35

Floor Plans & Sectionspg 40

Structural Plans.....pg 50

Experience.....pg 57

CHAPTER FIVE

Costs.....pg 62

Cost per Assembly.....pg 63

Summary Cost Comparison.....pg 70

Costing Sheets.....pg 72

Bid Analysis.....pg 79

Take-offs.....pg 84

Credits.....pg 90

CHAPTER SIX

Schedule.....pg 91

Schedule Analysis.....pg 92

Summary Schedule.....pg 94

Detailed Schedules.....pg 95

Productivity Analysis.....pg 103

Credits.....pg 113

CHAPTER SEVEN

Environment.....pg 114

Analysis Summary.....pg 115

LCA Results.....pg 118

Material Quantity Input.....pg 119

Credits.....pg 123

CHAPTER EIGHT

Conclusion.....pg 124

APPENDIX A.....pg 126



CHAPTER ONE:

Introduction

A. Thesis Statement

Introduction:

CLT, otherwise known as Cross-laminated Timber is a 'mass' timber building material consisting of nominal lumber stacked crosswise and glued together into panels. Originally developed in Switzerland in the 1990's, CLT lacked the proper testing and impetus to have a strong impact on the market. With the green building movement, better efficiencies, and improved marketing and distribution channels, it quickly established itself in European jurisdictions as a sustainable alternative to industry standard construction products in the following decades¹. Europe has continued to pioneer CLT construction, with the first 10 story upscale residential Forte Building (2012) constructed in Australia. While CLT has established itself as a popular green alternative building material in Europe, its use in North America and particularly in the Pacific Northwest has been limited. Vancouver, Canada has made the greatest advancements, implementing CLT for the construction of two buildings on the University of British Columbia campus: the 5 story Earth Sciences building in 2012 and the 4 story Bioenergy Research & Demonstration Facility in 2014. In the US, projects have remained at a much smaller scale, but interest in CLT continues to grow. The largest proposed domestic project is a 7 story wood office building in Minneapolis, scheduled to be completed in 2016 for Hines Interests².

The primary reason for implementing CLT and mass timber in the built environment stems from its widely acknowledged status as a renewable resource which, forested sustainably, can have an overall carbon negative impact. Based on estimates from the US Department of Agriculture (USDA), a modest 4 story building made from CLT could "cut emissions on par with taking 500 cars off the road for a year"³. Because buildings account for 38-40% of carbon dioxide (CO₂) emissions in the US, there is an opportunity to explore the use of mass timber for office construction, which may provide for the most significant energy savings⁴.

Whether CLT has the capability to break into the building market as an alternative building material in Seattle depends on the ability of mass timber to compete with industry standard construction materials for building typologies that are typically mid-high rise, such as residential towers and commercial office buildings. To date, CLT has been used primarily for residential and institutional applications. While residential buildings make up a large portion of the built environment, censuses show that office buildings also dominate the market. According to the EIA database for 2012, of all buildings constructed in the US in that year, 18% corresponded to office buildings, greater than any other building typology (EIA). In Seattle, of 93 active projects in 2014, 58 were residential buildings and 13 (next highest category) were office buildings⁵.

¹ Karacabeyli, Erol, and Brad Douglas, eds. "CLT Handbook." (2013): n. pag. *Seattle Department of Planning and Development*. FPI Innovations. Web.

² Black, Sam. "Hines Plans Seven-story Wooden Office Building in Minneapolis' North Loop (Photos) - Minneapolis / St. Paul Business Journal." *BizJournals*. N.p., 5 Nov. 2014. Web.

³ Harris, Mark. "The World's Next Tallest Building-Made of Wood? :: How We Get To Next." *How to Get to next*. N.p., 7 Oct. 2014. Web.

⁴ PWC. "Real Estate 2020 - Building the Future." *PWC*. PWC, 2014. Web.

⁵ "Development and Construction Projects in Downtown Seattle." *Downtown Seattle*. N.p., n.d. Web.

Unfortunately the current Seattle building code limits buildings made of wood products to no more than 85ft in height and no more than 6 stories, which makes it very difficult for mass timber to compete with other construction materials⁶. Nevertheless, the creation of a US Handbook for CLT, as well as the inclusion of this new construction material into the IBC may herald a new age of wood building. For the purposes of this thesis, it will be assumed that fire code limitations for wood construction will be lifted, such that mass timber towers can reach heights of 10 stories or 125'.

Thesis Statement:

Most office building construction relies on steel and concrete for mid-high rise office building applications. The primary goal of this thesis is to understand the implications of CLT and mass timber construction systems for mid-high rise office buildings in Seattle by developing a prototypical office building located on a specific site. This research thesis will focus on comparing this prototypical mass timber office building design to the same/similar design using industry standard construction materials for Seattle. The criteria for comparison will include code, cost, schedule and greenhouse gas emissions.

Procedure:

In order to determine the advantages/disadvantages of a CLT office building in Seattle, a generic open plan office building design will be generated based on office building design standards, but which is tailored to a specific site (assumed in this initial design will be industry standard construction materials for structural spans/loads). This plan will then be analyzed and reconfigured to match the structural requirements of CLT and mass timber, combined with a concrete core for shear resistance. The outcome of this process will be to produce one final mass timber structural design, which will be chosen based on how well it conforms to set design standards. Quantities will be produced from both design options and will assist in generating construction estimates and schedules for these hypothetical office buildings. A Life Cycle Analysis (LCA) will also be performed on the buildings to determine the environmental impact of mass timber as compared to concrete and steel construction. The prototype building will be designed such that it can be located in a dense urban environment, specifically Seattle's South Lake Union district.

Initially, the hypothetical building design will be generated based on office design standards, South Lake Union design goals and building code requirements. The office building design(s) will be modeled and developed in Revit, which will generate quantities that can be used for cost, scheduling and environmental analysis. To determine costs of construction, historic SF data will be used for generic finishes/foundations. CLT per SF costs will be obtained from a large selection of manufacturers and distributors. Any mechanical, electrical or plumbing costs will be gauged through interviews with industry personnel who have experience with CLT construction. The schedule for the project will be developed through careful considerations of site logistics, particularly staging, hoisting and placing of CLT panels. This will be determined through conversations/correspondence with experienced industry professionals and through conversations with CLT manufacturers. An LCA of the project will be produced using Athena. This will be compared to the same office building as though it had been built using conventional materials. More information on the methodology for thesis will be provided in Chapter 3.

⁶ "Development and Construction Projects in Downtown Seattle." *Downtown Seattle*. N.p., n.d. Web.

B. Thesis Rationale:

Cross Laminated Timber (CLT) & Mass Timber:

Several advancements in the use of CLT in the Pacific Northwest indicate that this material may soon have a place in Seattle's construction market. Canada originally published the CLT Handbook in 2011, facilitating CLT construction under the "Alternative Solutions" path in the Canadian building codes (Handbook). Two years later, the US version of the CLT Handbook was published in 2013. In 2015, CLT will be added to the International Building Code (IBC), where it will have its own product chapter.

Canada remains at the forefront of CLT implementation in the Pacific Northwest. Canadian Architect Michael Green has developed a Tall Wood project that hopes to push for the implementation of tall wood buildings around the world. Green and his team have come up with a cost-effective wood structural system called Finding the Forest Through the Trees (FFTT) that utilizes CLT panels and engineered wood products⁷. According to Green, FFTT achieves a much lighter carbon footprint than the functionally equivalent concrete and steel systems and at a competitive price⁸. A series of CLT projects in British Columbia and Vancouver have already implemented mass timber building strategies. These include: Earth Sciences Building, Bioenergy & Research Facility, Greg Dowling Residence, and Murray Grove Tower.

Canada is currently on its way to including CLT in the Canadian Standard for Engineering Design in Wood and in the National Building Code of Canada. In the US, CLT has only begun to garner interest in the last few years. The Long Hall in Whitefish, Montana is the first commercial building to be made primarily of CLT panels⁹. In Seattle, Architect Susan Jones has overseen the design and construction of her private residence built primarily out of CLT and scheduled to be completed in 2015. The construction of the Hines Interests all wood office tower in Minneapolis in 2016 will generate further impetus for this construction technology. Seattle currently does not allow for wood buildings above 6 stories, but there is reason to hope this code limitation will be modernized in the next few years.

One of the reasons for the popularity of CLT in BC is due to the abundance of beetle kill pine, which can be readily employed in the creation of CLT panels. In Seattle, WA, there are opportunities to more actively engage the forestry sector by popularizing mass timber building technology. According to the 2014 *Olympic Peninsula Economic Development Initiative* by Representative Derek Kilmer, the Olympic Peninsula contains the highest unemployment rate in the state. Kilmer proposes to support parties who are interested in researching, producing, and using CLT to identify how they can work together and create jobs in the community (Kilmer).

⁷ Loomans, Taz. "Michael Green on Why Wood Skyscrapers Are Better than Concrete and Steel Towers." *Inhabitat Sustainable Design Innovation Eco Architecture Green Building Michael Green on Why Wood Skyscrapers Are Better than Concrete and Steel Towers Comments*. N.p., 16 July 2013. Web.

⁸ Loomans, Taz. "Michael Green on Why Wood Skyscrapers Are Better than Concrete and Steel Towers." *Inhabitat Sustainable Design Innovation Eco Architecture Green Building Michael Green on Why Wood Skyscrapers Are Better than Concrete and Steel Towers Comments*. N.p., 16 July 2013. Web.

⁹ Woodworks. "Cross Laminated Timber Makes Its Mark with the Long Hall." *Woodworks Case Study*. Woodworks, 2012. Web.

Environment:

Buildings currently account for 39 percent of total energy use, 12 percent of the total water consumption, 68 percent of total electricity consumption and 38 percent of the carbon dioxide emissions in the United States¹⁰. Clearly, the built environment has a huge impact on the natural environment, and finding a building construction methodology that can effectively reduce the environmental impacts of construction projects, particularly new construction, can improve the quality of life for future generations. As defined by the EPA, benefits of green building technologies include the following: enhance and protect biodiversity and ecosystems, improve air and water quality, reduce waste streams, conserve and restore natural resources, reduce operating costs, create, expand, and shape markets for green product and services, improve occupant productivity, optimize life-cycle economic performance, enhance occupant comfort and health, heighten aesthetic qualities, minimize strain on local infrastructure, improve overall quality of life.

Sustainability credentials for building are becoming increasingly important in the building market, and many owners and developers choose to pay a premium for certification. Based on a real estate survey for 2020, it's likely that all buildings in advanced economies will need to have sustainability ratings; office buildings that don't have green certification are likely to see a decreased life span¹¹. For many corporations, investing in green buildings can be both practical and profitable for several reasons:

- Commercial tenants or owner/operators of sustainable green commercial buildings see tangible economic benefits including increased rental rates, improved occupant comfort, and increased stock prices
- Greening existing buildings can increase property value while decreasing operating costs
- A public entity, such as a city or a university, can make strides in improved image and demonstrate to citizens and students that the organization focuses on environmental issues¹².

There are many green building certification systems that gauge a building's energy performance such as Green Globes, LEED, and Living Building Challenge. Many of these rating systems focus on the building's performance and energy use but also include an evaluation of materials used in construction. Life Cycle Analysis (LCA) takes a more comprehensive "cradle to grave" approach to a construction project, quantifying emissions from sourcing raw materials to disposal. To assess the environmental impacts of a tall timber building, an LCA will be conducted, such that a holistic analysis can be reviewed.

¹⁰ EPA. "Why Build Green?" *EPA*. Environmental Protection Agency, n.d. Web.

¹¹ PWC. "Real Estate 2020 - Building the Future." *PWC*. PWC, 2014. Web.

¹² Batcher, Kathleen, Phil Davis, Olivier Demazure, Scott Henneberry, Satish Kumar, and Andy Marsh. "Why Invest in High-performance Green Buildings?" *Whitepaper* (n.d.): n. pag. *Schneider-electric*. Schneider Electric, June 2012. Web.

Site:

South Lake Union has been chosen as the location for analysis because it is one of the few districts in Seattle that has undergone a tremendous amount of development in the last few years. The district has been rezoned with the following goals in mind:

- Advance the City's growth management strategy as set out in the Comprehensive Plan and South Lake Union Neighborhood Plan
- Promote a neighborhood that will provide a more diverse mix of housing and employment
- Support the continued growth of the city's economy
- Encourage a safe and active pedestrian environment
- Create new infrastructure financing tools that, together with affordable housing incentives and direct City investments, will:
 - Provide the critical public infrastructure needed to support the area's dramatic growth
 - Ensure South Lake Union remains an attractive and livable neighborhood for all who live and work there.¹³

The district hopes to "support growth of 12,000 households and 22,000 jobs over the next 20 years"¹⁴. Clearly, the neighborhood intends to continue to densify. A South Lake Union location is ideal for the purposes of this study because it is an area where office building construction and development has been very active. Seattle's South Lake Union district has recently been rezoned with a specific aim to increase density. Some major players in the development of this area include Amazon, and in three years' time the addition of Expedia and some 1500 employees to Elliott Bay¹⁵.

Building Typology:

Most tall wood buildings constructed to date are residential towers, and there is a large number of case studies that have tried and tested CLT and mass timber construction for residential applications. These include the multi-family building in Judenburg, Austria, multi-family building in Chibougamau, Canada, multi-family building in Berlin, Germany, multi-family building in Vaxjo, Sweden and the 10 story apartment building in Australia¹⁶.

Office and commercial buildings have also been constructed, but mostly in low rise applications. Some examples of these include Impulsezentrum in Graz, Austria, Montana Long Hall, Viken Skog BA in Honefoss, Norway, and Juwi Head office in Worrstadt, Germany. Given that office building makes up for almost 20% of the construction market, the lack of implementation of CLT for office building typologies begs the question of whether mass timber can branch out to a building typology that has thus far relied on popular construction materials such as steel and concrete.

¹³ "Development and Construction Projects in Downtown Seattle." *Downtown Seattle*. N.p., n.d. Web.

¹⁴ "Development and Construction Projects in Downtown Seattle." *Downtown Seattle*. N.p., n.d. Web.

¹⁵ Moreno, Amy. "Expedia Move to Seattle Expected to Impact Traffic." *KING5*. N.p., 2 Apr. 2015. Web.

¹⁶ Karacabeyli, Erol, and Brad Douglas, eds. "CLT Handbook." (2013): n. pag. *Seattle Department of Planning and Development*. FPI Innovations. Web.

Cost & Schedule:

The implication of tall wood office buildings on construction costs and schedule can have a tremendous impact on the adoption of this new construction building type. Recent research conducted by Walsh Construction and Mahlum Architects suggests that “as compared to [a] base 10-story concrete building, the CLT option offered an estimated 4% cost savings”¹⁷.

B. Thesis Overview

In order to test feasibility of tall timber construction in Seattle, this thesis will produce the following:

- An office building design for a specific site in South Lake Union (both a mass timber and industry standard material version)
- Analysis on that building based on the following criteria:
 - Ability to conform to design requirements
 - Cost
 - Schedule
 - Greenhouse gas emissions

¹⁷ Mahlum Architects. "A Study of Alternative Construction Methods in the Pacific Northwest." *CLT Feasibility Report* (n.d.): n. pag. Mahlum. 14 May 2014. Web.

CHAPTER TWO:

Literature Review

A. Literature Review

Primary literature review will be conducted on CLT & Mass Timber, which will include all code issues as well as environmental analysis. Of particular focus for this thesis will be any research/literature that focuses on tall wood buildings. Other literature that is applicable to this study will include any office building design standards documents as well as the design guidelines for South Lake Union:

*Tall Wood Building Study*¹: This study, spearheaded by Michael C Green, is geared specifically to evaluating the feasibility of tall mass timber buildings in Vancouver, BC, Canada. In Vancouver, tall office buildings on top of a large podium are fairly prevalent, particularly in downtown areas. The study explores the potential positive impacts of tall timber on climate change, analyzes Canadian precedents, and includes a section on material and systems research and a section on the evolution of the building code. The study focuses on a specific building project for an in depth analysis of a case study 'design' which not only covers code design but also looks at costs, schedule and constructability. This study is similar in scope to what my thesis would like to explore, but focuses on a much taller building, but also includes a structural analysis of how the building may respond to earthquake loads.

*CLT Feasibility Study*²: This study is a project undertaken by Walsh Construction and Mahlum Architects to study how a 10 story CLT structure compares to a similar structure made from commonly found materials. Discussed in this study are several building methods and proposed details that are needed to meet code and some detailing strategies. The building is a mixed use multi-family project on a concrete podium. The three alternatives considered in this study are Steel structure on concrete, full concrete structure and CLT timber structure on concrete. This study makes some broad generalization about costs, but does not provide detailed breakdowns of cost research or appendices with data for reference. It also does not provide any detailed information on expected schedule savings. It appears to tackle the same issues that will be the focus of my research, but looks primarily at the popular mixed use building typology, while the focus of my study will be on office buildings.

*Progress on the Development of Seismic Resilient Tall CLT Buildings in the Pacific Northwest*³: (REF: Pei)
The purpose of this study was to analyze the roadblocks for implementing CLT in the US, develop a roadmap for building multi-story CLT buildings and to lay out a conceptual lateral CLT system that can be implemented to achieve resiliency under earthquake to loads. While some general code issues are touched upon in the study, the main focus is on the seismic performance of a CLT building and potential damage that would occur following a major seismic event. Developing an efficient and code compliant lateral system in CLT is a complex task, which requires engineering skill and background. In order to focus the scope of my own research, I will be relying on concrete for the lateral system.

¹ Green, Michael C. "The Case for Tall Wood Buildings." Mgb Architecture + Design, 22 Feb. 2012. Web.

² Mahlum Architects. "A Study of Alternative Construction Methods in the Pacific Northwest." *CLT Feasibility Report* (n.d.): n. pag. Mahlum. 14 May 2014. Web.

³ Pei, Shiling, Jeffrey Berman, Daniel Dolan, John Van De Lindt, James Ricles, Richard Sause, Hans-Erik Blomgren, Marjan Popovski, and Douglas Rammer. *Progress on the Development of Seismic Resilient Tall CLT Buildings in the Pacific Northwest* (n.d.): n. pag. WCTE 2014, 10 Aug. 2014. Web.

*Market and Environmental Assessment of CLT Production in the Olympic Peninsula - Mid-Rise Non-Residential Construction Application*⁴: This research endeavor is beginning at the University of Washington. The research project will explore market feasibility for manufacturing CLT in Washington State (specifically on the Olympic Peninsula). The focus of the study is on the mid-rise nonresidential green building industry in the Pacific Northwest. An LCA of a generic CLT building will also be conducted. One of the members of this study, Kate Simonen, is a member of this thesis committee and a great resource for my own research, particularly as pertaining to mid-rise nonresidential building and LCA analysis.

*UT System: A Structural System to Build Taller Urban Timber Houses with the Aspired Spatial Flexibility*⁵: This study looks at some current building methodologies using CLT and timber in mid-rise applications. The study identifies four different building methods with CLT: monolithic, CLT/concrete, CLT/Steel and Urban Timber (UT). It analyzes which system is appropriate for which building typology, but most of the paper is focused on the intricacies and connection detailing of the UT system, which is an all wood system that can provide some spatial flexibility while remaining all wood. This article, while only providing detailed information on an all wood building, is nonetheless useful because of the connection details and moisture control considerations.

*Olympic Peninsula Economic Development Initiative: Strengthening the foundations of economic growth, promoting innovation and entrepreneurship, and protecting our most precious resources*⁶: The purpose of this initiative is to reinvigorate the economy of the Olympic Peninsula. One of the proposed methods to achieve this goal is to promote new wood and timber technologies, such as CLT. Kilmer would like to bring together the parties who are interested in researching, producing and using CLT to identify how they can work together and create jobs in the community.

*Cross Laminated Timber, Life Cycle Analysis Site Impacts*⁷: The study assesses the impacts associated with CLT construction, specifically focusing on the materials used in CLT assemblies for walls, floors and roofs. This results of this study will be very useful in helping when generating an LCA for my own project. However, the details used in this study will have to be analyzed against those used in the case study that will be developed for this thesis.

⁴ Simonen, Kathrina. University of Washington. Expert opinion 2015

⁵ Silva, Catarina, Jorge M. Branco, and Paulo B. Lourenco. "UT SYSTEM: A STRUCTURAL SYSTEM TO BUILD TALLER URBAN TIMBER HOUSES WITH THE ASPIRED SPATIAL FLEXIBILITY." *ResearchGate*. N.p., 16 Dec. 2014. Web.

⁶ Kilmer, Derek. Warnke, Kevin. *OLYMPIC PENINSULA ECONOMIC DEVELOPMENT INITIATIVE* (n.d.): n. pag. US House of Representatives, 17 Jan. 2014. Web.

⁷ Morrison Hershfield. "Cross Laminated Timber, Life Cycle Analysis Site Impacts (Revised)." The Athena Institute, 16 Apr. 2015. Web.

*Test Report Prepared for American Wood Council*⁸: This is a report of a test done by the NGC Testing Services in Buffalo, NY for the American Wood Council of the fire performance of CLT. The test was done on a 5-ply panel of CLT with a layer of 5/8" gyp on either side. The wall was loaded to the maximum load attainable by the testing office. The specimen lasted just over 3 hours before failing. The outcome of this study is a burn rate for CLT structures that legitimizes its use for mid rise applications. The results of this study will be used to justify a hypothetical lifting of current fire code restriction on tall wood construction options.

*Direct Impact Sound Insulation of Cross Laminate Timber Floors with and without Toppings*⁹: Internoise conducted an acoustical test in September of 2013 with the support of Canadian Wood Council, FPInnovations and the Provinces of Quebec and Ontario. The intent of the study was to analyze the direct impact air borne sound insulation of CLT floor and the direct airborne sound insulation of CLT walls as well as on the structure borne sound transmission on a series of CLT building junctions. The study concluded that of the different connection methods tested, it was found that junction transmission in the continuous floor slab is strongest and independent of the connection methods of the walls. The results of this test bring up a series of issues that will have to be addressed in the detailing of the case study.

*Solid Wood: Case Studies in Mass Timber Architecture*¹⁰: The book is one of the only published books on CLT that includes details, case studies and descriptions of methodology on CLT and mass timber architecture. It includes some historical context, the environmental justification for using wood in buildings and recent developments in fire, acoustical and weather performance. One of the most useful aspects of this study is the number of case studies and details for wood construction. These may prove to be very helpful for the development of details for the purposes of this thesis.

*Real Estate 2020 – Building the Future*¹¹: This report, published by PwC, represents a number of predictions and visions of the future built environment for the asset management industry. The report looks at real estate's changing landscape, such as the expansion of cities and shifts in population drive, and how sustainability will transform the design of buildings and developments. It also looks at the implications of these predictions for real estate strategies and offers some success factors. The report supports the prediction that tall wood office buildings may become a popular building typology in the future, given wood's environmental performance characteristics and the need for more mid-high rise buildings in denser urban environments.

⁸ Rizzo, Michael J. "Test Report for American Wood Council." (n.d.): n. pag. AWC. NGC, 15 Oct. 2012. Web.

⁹ Zeitler, Brendt, Stefan Schoenwald, and Ivan Sabourn. "Direct Impact Sound Insulation of Cross Laminate Timber Floor with and without Toppings." (n.d.): n. pag. Internoise, 2014. Web.

¹⁰ Mayo, Joseph. *Solid Wood: Case Studies in Mass Timber Architecture, Technology and Design*. N.p.: n.p., n.d. Print.

¹¹ PWC. "Real Estate 2020 - Building the Future." PWC. PWC, 2014. Web.

*Building Permits Survey*¹²: This is a government website that tracks the number of buildings throughout the country by year based on the number and type of permits. As such, it is a great resource for determining the number of a particular building type as compared to the total permitted buildings in the country. It was used in this thesis to determine the popularity of the office building typology and to justify this typology for CLT and mass timber construction research.

B. Precedent Analysis

Precedents analyzed in this study will be primarily tall wood buildings. These buildings may prove useful in the development of the case study model for the purposes of this thesis.

*Susan Jones House, Seattle, WA 2015*¹³. This is a single family dwelling designed by Susan Jones of Atelier Jones. It uses a combination of CLT panels with steel structural support members and a concrete foundation. Susan Jones is a member of my committee and an excellent resource for my own project.



¹² US Census. *Building Permits Survey*. United States Census Bureau, 2012. Web. 20 June 2015.

¹³ Lloyd, Alter. "CLT House by Susan Jones Shows the Future of Sustainable, Green and Healthy Housing." *TreeHugger*. N.p., 30 Mar. 2015. Web.

*Long Hall, Whitefish, Montana, 2012*¹⁴. The first commercial building built using CLT in the US is the Long Hall in Whitefish, Montana. The project was completed in 2011 and included a project team consisting of Datum Drafting Design, Innovative Timber Systems and DBS Engineering & Consulting. The project proved to be cost competitive, as the ability to leave CLT exposed on the interior of the building saved money on finishes. Another benefit to CLT construction was that there was the ability to preassemble panels off-site. The site in this case had very restricted access, with only 30" between neighbors.



*Earth Sciences Building, UBC Campus, BC*¹⁵ (2012). Designed by Perkins + Will, both buildings entailed a considerable amount of innovation that was beyond current code prescriptions, therefore feasibility research and testing, particularly on ambient vibrations was done. As a mass timber building, the Earth Sciences building sequesters 1000tons of CO2 from the atmosphere, which is equivalent to taking 415 cars off the road for a year.



¹⁴ Woodworks. "Cross Laminated Timber Makes Its Mark with the Long Hall." *Woodworks Case Study*. Woodworks, 2012. Web.

¹⁵ Gauer, James. "Sciences Building." - *Perkins+Will*. N.p., Mar. 2013. Web.

*Bioenergy Research and Demonstration Building, UBC, BC (2013)*¹⁶. This building, also designed by Perkins + Will for the University of British Columbia campus was created using CLT. It is a 4 story structure.⁷³



*Office Building, Minneapolis, Minnesota (2016)*¹⁷. (REF: Black). Hines Interests is a developer that plans to build a seven story wood office building in downtown Minneapolis. The building will be designed by Michael Green.



*Forte Building, Australia, 2012*¹⁸. This building is one of the tallest CLT buildings in the world. It was designed by Lend Lease and CLT was supplied by KLH. This project is an upscale, 5 star residential

¹⁶ Districtenergy. "UBC Bioenergy R&D Facility Is World's First Community-scale CHP Biomass System." *International District Energy Association*. N.p., 22 Oct. 2013. Web.

¹⁷ Black, Sam. "Hines Plans Seven-story Wooden Office Building in Minneapolis' North Loop (Photos) - Minneapolis / St. Paul Business Journal." *BizJournals*. N.p., 5 Nov. 2014. Web.

¹⁸ Lend Lease. "Forte: Creating the World's Tallest CLT Apartment Building." *FORTÉ* (n.d.): n. pag. *Presentation*. Woodworks, 2013. Web.

building. It would be useful for the purposes of this thesis to use this building as a sample case study for structural design purposes.



C. Additional Research

This portion will include a brief summary of other resources used to assist the thesis project. More information from these sources can be found in the Appendices.

*CLT Handbook, US Edition*¹⁹: This handbook is geared towards architects and engineers and includes calculations and details for those interested in designing with this material. The Handbook covers the following sections: manufacturing, structural design, lateral design, connections, duration of load and creep factors for CLT panels, vibration performance, fire performance, sound insulation, building enclosure design, environmental performance and lifting and handling of cross laminated timber elements.

*Timber Tower Research Project*²⁰: *Gravity Framing Development of Concrete Jointed Timber Frame System*. This is a research project developed by SOM to study the gravity framing systems inherent to tall timber structures. The purpose of this test was to develop potential structural details which would achieve acceptance criteria.

¹⁹ Karacabeyli, Erol, and Brad Douglas, eds. "CLT Handbook." (2013): n. pag. *Seattle Department of Planning and Development*. FPI Innovations. Web.

²⁰ SOM. "Timber Tower Research Project: Gravity Framing Development of Concrete Jointed Timber Frame System." SOM, 30 May 2014. Web.

*Timber Tower Research Project*²¹: This is an earlier study done by SOM to determine the structural design and architectural design requirements for a tall timber structure.

*Component Catalogue for Cross Laminated Timber Structures*²²: This component catalogue presents a series of details, similar to a tool kit of parts for CLT construction, including foundations, openings and structural connection details.

*Facilities Standards for the Public Building Service*²³: This document, provided by the Whole Building Design guide offers performance standards and criteria for designing office buildings for the GSA.

*Space Type: office*²⁴: Offers typical finishes for GSA spaces based on type of space.

*South Lake Union Urban Design Framework*²⁵: This document provides information on the design framework and requirements for buildings in South Lake Union. It includes street character, setbacks information, building form and street character requirements.

2012 Seattle Building Code: Existing building code for the city of Seattle.

*Shell & Core Office Building, GSA*²⁶: This source shows a detailed case study report on GSA standard office spaces. It compares a low rise, mid-rise and high-rise office space costs and includes a breakdown of typical materials and assemblies used for GSA buildings. The detailed breakdown charts of GSA standards will be used to price the work at a schematic design level.

*Construction Criteria for Office Space*²⁷: (REF: GSA). This is a more upper level version of GSA's criteria for office space design. It includes interior finishes and mechanical, electrical, plumbing and life-safety systems breakdowns.

This concludes Chapter 2 of this thesis document. Presented above and in the appendices are resources currently available for use and implementation into this thesis research effort. This thesis hopes to build upon existing language. These resources will be used primarily to assist with design, particularly as pertaining to office building standards and requirements, detailing of connections, structural design of tall timber structures and other relevant information. Costs, logistics and schedules will be obtained from interviews with industry professionals.

²¹ SOM. "Timber Tower Research Project." SOM, 6 May 2013. Web.

²² KLH. "Component Catalogue for Cross Laminated Timber Structures." (n.d.): n. pag. KLH, Jan. 2011. Web.

²³ GSA. *Facilities Standards for the Public Buildings Service*. Washington, D.C.: U.S. General Services Administration, Office of the Chief Architect, n.d. Whole Building Design Guide, 2015. Web.

²⁴ GSA. "Space Type: Office." *Monthly Labor Review* 43.6 (1936): 1516-542. WBDG. GSA. Web.

²⁵ City of Seattle. "South Lake Union Urban Design Framework." (n.d.): n. pag. *Seattle.gov*. Seattle DPD, 31 Dec. 2010. Web.

²⁶ Seattle DPD. "Existing Building Code." - *Seattle Department of Planning and Development*. N.p., n.d. Web.

²⁷ GSA. *Shell & Core: Office Building* (n.d.): n. pag. 2012. Web.

CHAPTER THREE:

Methodology

A. Thesis Goals & Objectives

The primary goal of this thesis is to explore the implications of a 10 story office building located in Seattle as compared to the same building made of industry standard materials on cost, schedule, and environment. The exploration will focus on a specific case study office building designed for a particular site in South Lake Union.

1. Goals

The goals of the thesis will be to produce the following:

1. A 10 story office building design in Seattle. One design will use mass timber and the other will use industry standard materials.
2. A cost assessment on the tall timber office building to a tall office building made of industry standard materials. This will culminate in a cost/SF to cost/SF comparison, highlighting areas of greatest savings.
3. A scheduling assessment on the tall timber office building to a tall office building made of industry standard materials. This will culminate in a final schedule length comparison to final length comparison, highlighting areas of greatest savings.
4. A LCA of the building once the design has been complete. An LCA of the same building using typical construction materials and an analysis of environmental savings/losses.

Personal Goals:

1. A greater understanding of timber construction methods, spanning requirements and design strategies.
2. Further development of cost estimating and project scheduling skills.
3. Further development of BIM modeling tools and quantification.
4. A greater understanding of LCA programs and environmental impact of material choices.

2. Final Deliverables

The final deliverables produced out of the effort of this thesis are:

1. Final building design including:
 - a. Ground floor plan(s), typical floor plan(s)
 - b. Elevations, Sections
 - c. Building Diagrams
 - i. Structural Systems
 - ii. Space Planning
 - iii. Siting
 - d. Construction Sequence Diagrams/Animation
2. Final Cost Summaries with Cost/SF
3. Final Schedule Durations
4. LCA Results

B. Site Selection & Analysis

The site selected will be a hypothetical site located in the South Lake Union district of Seattle. A particular site will be selected for the purpose of schedule analysis for this particular case study. The site selected will be selected based on its suitability as a standard site for office building construction. Information on new zoning requirements for this district can be found in Appendix F.

Site Description

- **Parcel #:** 7863500040
- **Republican & Fairview**
- **SM160**
- **21600 SF**
- Currently undergoing construction for biomedical office building
- FAR 7 – only if using the incentive program, otherwise use base FAR of 5.
 - SF can be added by purchasing farm credits and forest credits (first 200 credits purchased count as farm credits for King, Snohomish and Pierce counties)
- FAR 5 (Base and what will be used for this project):
 - $5 \times 21600 = 108,000$ SF. P2, P1 and L1 (if all commercial) are exempt from FAR
 - $180 \times 100 = \mathbf{18,000SF}$. $108,000SF / 18,000SF = \mathbf{6}$ floor plates.
 - Floor plate is roughly **180*100ft**.
 - **2 levels of parking below are excluded from FAR**
 - **1st level (ground floor) dedicated to commercial services – that square footage is excluded from the FAR requirements**

B. Program

The building program will conform to what is considered a standard office building typology as defined by the GSA (See Appendices). Because it is located on a specific site (South Lake Union), it will also conform to the design guidelines as specified in the South Lake Union Urban Design Guidelines and relevant codes (See Appendices).

C. Data Collection Avenues

Data collection will need to be obtained for material, labor and equipment costs, schedule durations, logistics and construction site plan, structural design requirements for CLT, CLT and mass timber connection and finish details, and finally, LCA performance of CLT.

Costs:

- Costs relating to CLT will be obtained from 3-6 manufacturers or vendors of this material closest to Seattle. The data obtained from these manufacturers will be used to create a mean, median and mode costs analysis basis.
- Costs relating to finishes, both interior and exterior will be obtained from historic cost/SF data from a general contractor and an estimating guide when applicable, such as RS Means.
- Costs relating to labor and equipment needed for construction will be obtained from interviews with 3-6 industry professionals who are familiar with CLT and mass timber construction methodology. Other costs and labor rates will be obtained from a GC's historic data and labor rates will be based on prevailing wage rates, which are publicly available.
- Costs relating to site logistics will be determined using historic data for what road/sidewalk closures cost as obtained from a general contractor.
- Mechanical, electrical and plumbing (MEP) costs will be produced from mechanical and electrical engineers, with particular focus on the differences between standard construction costs and tall timber construction costs. These costs will be included as a lump sum estimate from MEP subcontractors.

Schedule:

- 3-6 industry professionals who are familiar with the assembly times of CLT panels and mass timber wood elements will be consulted to determine labor times per panel. These professionals will also be consulted to determine how the installation may affect the schedule of other trades.
- Lead times for mass timber & CLT panels will be obtained from 3-6 different manufacturers in proximity to Seattle. These will be averaged for a single lead time for CLT panels and any other engineered wood products that will be used.
- Superintendents of general contractors will be consulted to generate a logistics plan for staging and handling of CLT panels. They will also be consulted regarding a typical logistics plan for a standard building and standard construction materials.

CLT & Mass Timber Design Data:

- Majority of data used will be from research already conducted. Guides such as the CLT Handbook and the Tall Timber Tower report from SOM will be used for basic spans, loads, connection details (code compliant envelope details).
- Industry professionals will be consulted on an as needed basis for assistance/review.
- Generic details as defined by the Handbook will be used unless a special circumstance is present in the design.

LCA and Environmental Performance

- The LCA will be performed using Athena. Information on the performance of CLT as well as other unknown construction materials is available in the Appendices as defined in Chapter 2.

Office Building Design Standards:

- This information will be obtained from public agencies, who are willing to make their design standards publicly available. Current (newer) buildings in Seattle will be surveyed to determine the standard construction materials.
- All other information on construction standards will be obtained from resources as specified in Chapter 2.

D. Method

In order to produce a viable and rigorous research experiment, control variables will have to be defined. Those variables which are not being controlled by the research exercise will be allowed to fluctuate for the purposes of analysis.

1. Controlled Variables

Throughout the design of the project, two separate models will be generated, one industry standard model and one model that encompasses mass timber building techniques. The progression of these two designs will be controlled in the following ways:

- *Building Program:* A single building design will be generated initially, based on industry standard building materials and the standards for office building design. Keeping the same program, this form will then be re-interpreted in mass timber and CLT.
- *Site:* The same site will be used for both buildings, which will ensure that all site use and logistical issues will be based on similar street use allowances.
- *Height:* The site limits building heights to 125'. This height should allow for a 7-10 story structure. The number of stories for both buildings will be controlled for an accurate cost comparison.
- *Finishes:* Both buildings will use the same finishes in similar spaces. In some areas, CLT/mass timber components may be left exposed, depending on fire code compliance (inferred from fire testing burn rates). Other options will be explored as alternates.

2. Free Variables

The following variables will be determined to be free variables that will be allowed to influence cost, schedule and environmental performance:

- *Building Form:* While both buildings will adhere to the same program, the form of the two office buildings may shift to optimize the structural bays of mass timber as opposed to industry standard materials. By allowing the building form to change to accommodate mass timber structural spans, the experiment hopes to more accurately model the anticipated design tendencies for this building typology based on mass timber construction methodologies.
- *Finishes:* General finishes for both buildings will be the same, however in some areas CLT may be left exposed should it be in compliance with fire code. Leaving CLT Exposed in areas throughout the building may more accurately model cost and scheduling differences as exposed wood is one advantage of mass timber construction that adds value to the design and potentially reduces costs for finishes.
- *Foundations:* The foundations of both buildings will be designed based on the total building loads. Because mass timber is more light weight than concrete and steel, it is anticipated that the CLT office building foundation will be smaller and lighter.

- *Floor to Floor height:* Although the number of stories for both buildings will be kept the same, the floor to floor height per floor may differ as a result of structural systems and ceiling plenum space requirements. Allowing this to be a free variable will more accurately quantify the differences between the two buildings.

3. Data Input:

Data input methodology that will produce the results for costs, schedule and environmental performance will be discussed in greater length in the following chapters. Summarized below are the expected strategies for dealing with data:

- *Cost:* For finishes and building structural materials, a generic cost/SF will be used, based on subcontractor quotes and where prices have not been quoted, based on historic costs. See CHAPTER 5 for pricing assumptions.
- *Schedule:* Labor hours will be assigned per cost unit of each type of material. These will be used to interpolate number of working days and used to develop an overall schedule. Inherent to this will be manufacturing times and lead times for mass timber. See CHAPTER 6 for schedule assumptions and results.
- *LCA:* Quantities of materials and assemblies will be run through Athena for both the industry standard office building design and the mass timber office building design. The material inputs will be by assembly where applicable and by quantity of material where applicable to get accurate results (See CHAPTER 7).

CHAPTER FOUR:

Design

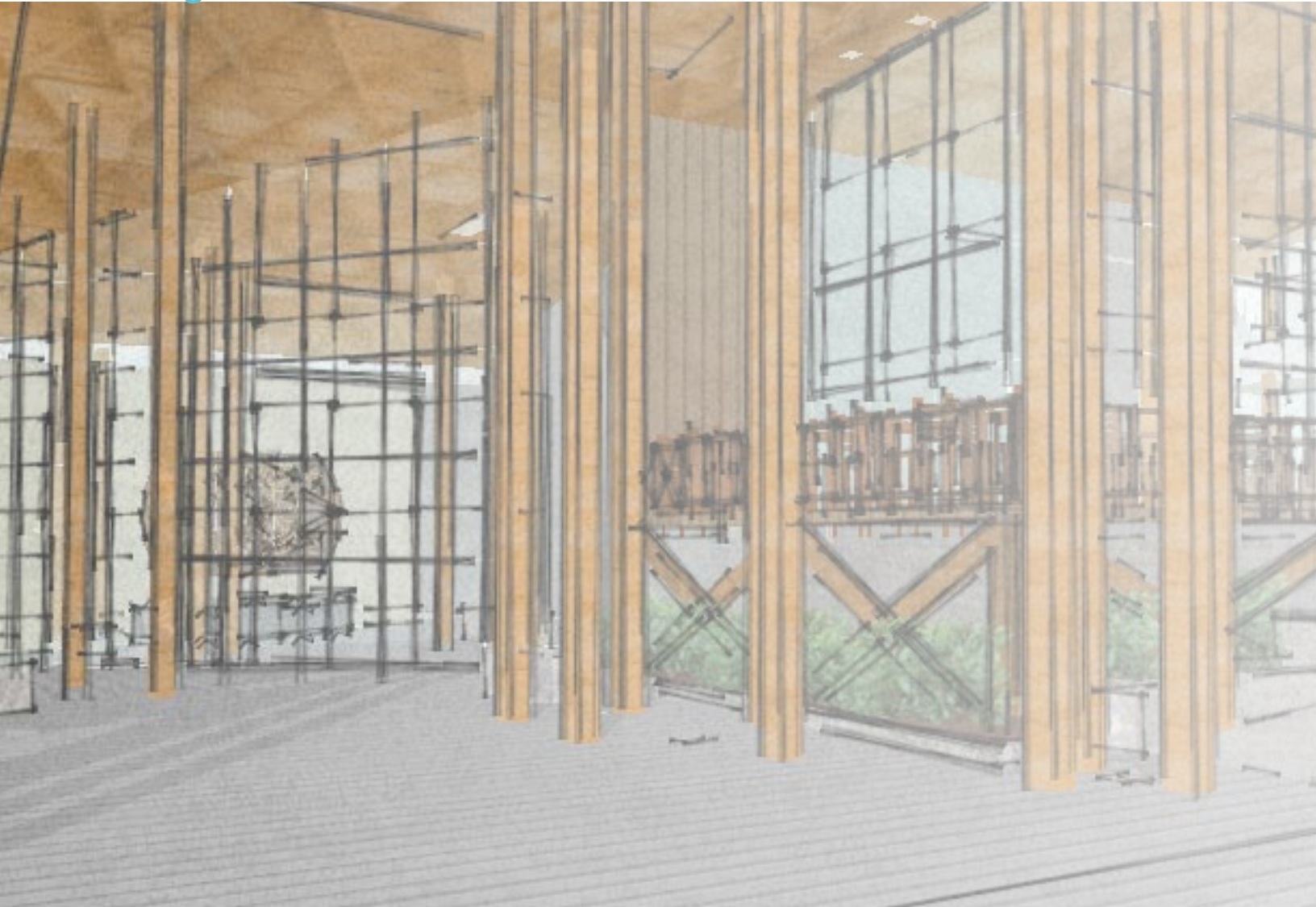

Design Guidelines/Assumptions:

- One specific building will be designed for analysis
- This building will be located on a specific site
- The design will attempt to follow the guidelines set up by the South Lake Union Urban Design plan
- Design finish details and specifics will be assumed to match the GSA standards for office buildings
- It will be assumed that there is no building code height limit on wood structures
- Two structural systems will be tested on the design, and changes will be analyzed

DESIGN: URBAN CONTEXT

South Lake Union Design Guidelines

As mentioned in previous chapters, the district of South Lake Union in Seattle has very specific goals which focus on incentivising public infrastructure and diversity to create a walkable neighborhood. The design of the building will attempt to address these goals, reiterated below for reference:

Advance the City's **growth** management strategy as set out in the Comprehensive Plan and South Lake Union Neighborhood Plan

Promote a neighborhood that will provide a more **diverse mix** of housing and employment

Support the continued growth of the city's **economy**

Encourage a safe and active **pedestrian environment**

Create new infrastructure financing tools, that together with affordable housing incentives and direct City investments, will:

Provide the critical **public infrastructure** needed to support the area's dramatic growth

Ensure South Lake Union remains an **attractive and livable** neighborhood for all who live and work there.



Image 1. City of Seattle. South Lake Union Urban Design Framework (n.d.): n. pag. Seattle DPD. Seattle DPD, 30 Dec. 2010. Web.

DESIGN: URBAN CONTEXT

Gateways, Hearts & Edges

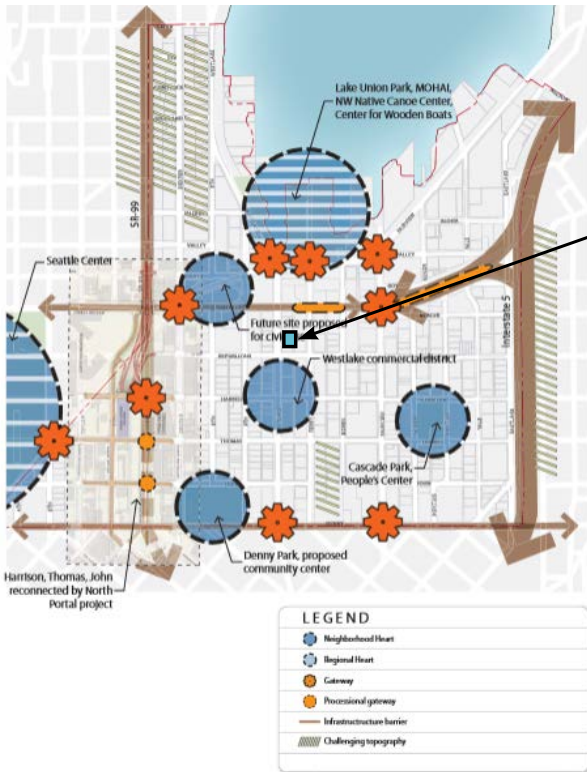

Our Site

Gateways

(Transitional Locations/Entries to SLU)

Hearts

(Centers of Commercial and Social Activity)

Edges

(Perimeters & Boundaries)

The South Lake Union Urban Design framework identifies zones within the district as gateways, hearts or edges (see above). The location of the site does not currently come into contact with any of these identified zones. In greatest proximity is the “edge” of Mercer St, which is just a block north of the site, and sees heavy traffic most of the day.

Image 2. City of Seattle. South Lake Union Urban Design Framework (n.d.): n. pag. Seattle DPD. Seattle DPD, 30 Dec. 2010. Web.

DESIGN: URBAN CONTEXT

SLU Take-Aways

Images 3 & 4. City of Seattle. South Lake Union Urban Design Framework (n.d.): n. pag. Seattle DPD. Seattle



- 1). Fairview is a boulevard & Central Street
- 2). Republican St is a neighborhood Street

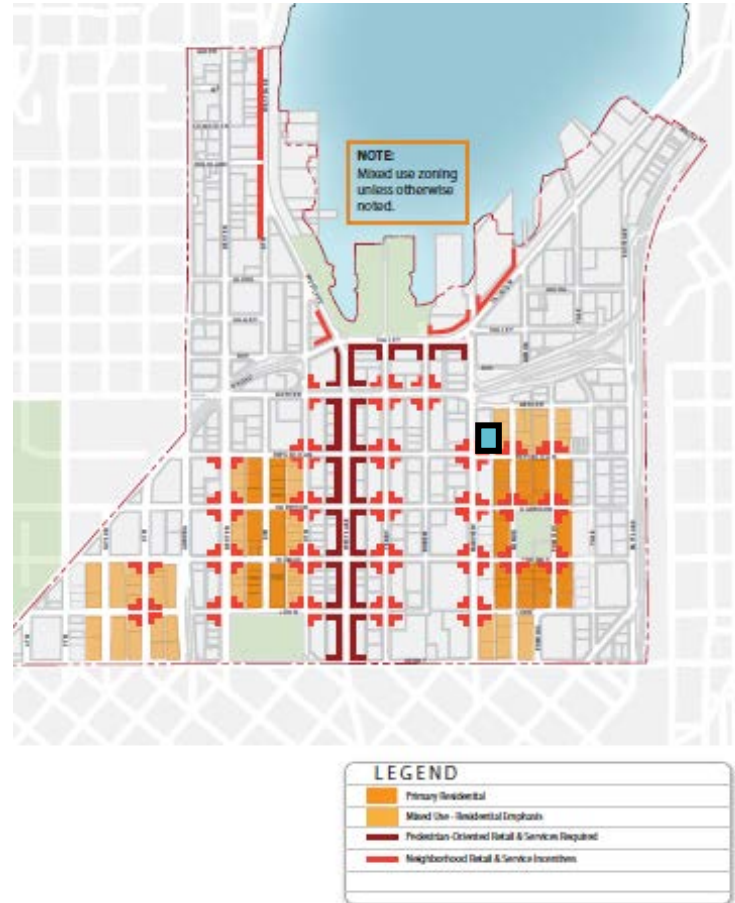

- 1). The corner of Fairview and Republican St. is a neighborhood retail and service zone

DESIGN: URBAN CONTEXT

SLU Take-Aways

Image 5. City of Seattle. South Lake Union Urban Design Framework (n.d.): n. pag. Seattle DPD. Seattle DPD, 30 Dec. 2010. Web.



LEGEND	
	SDP Designated Views
	Other View Corridors
	Upper Level Setbacks
	Recently Developed (or Utility) for Redevelopment

- 1). Fairview is a view corridor
- 2). There is a 10' setback required at Fairview above 65' .

The site, highlighted in blue on images 3,4 & 5 illustrates how the property relates to other major design factors of the urban design plan. Image 3 shows the site, located on Fairview and Republican St, as located both on a central and neighborhood street. In this instance, Fairview Ave N represents the 'central' street while Republican represents the 'neighborhood' street.

Image 4 shows the site in a position where neighborhood and retail service activities are anticipated.

Image 5 on the left depicts important view corridors to Lake Union. Streets that are considered view corridors have setback requirements at varying heights. Fairview, which borders the site to the west, is considered a view corridor and has a setback requirement as well, which will be discussed in the following section of this chapter.

DESIGN: URBAN CONTEXT

Neighbors

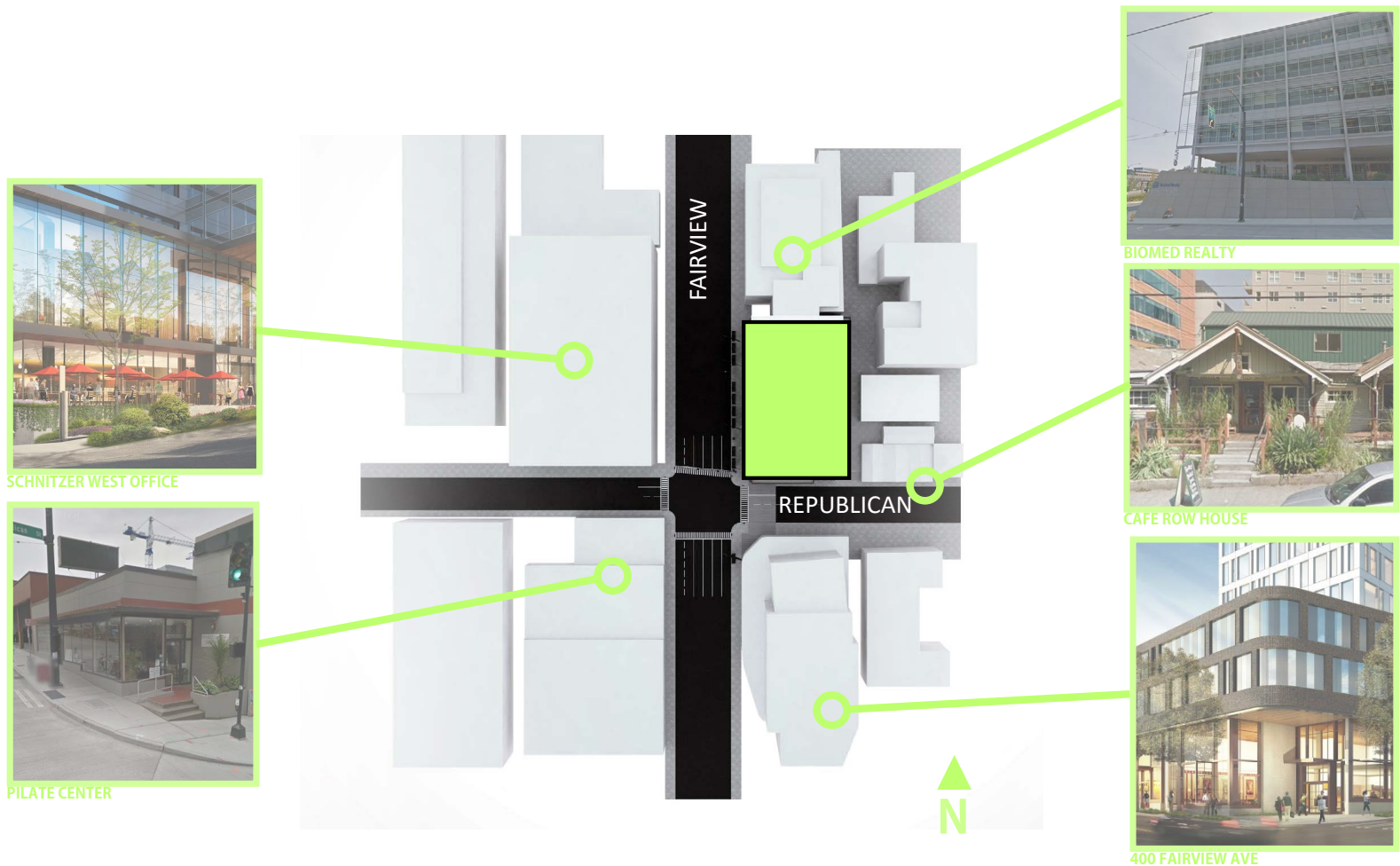

A closer look at the immediate site context reveals a series of large buildings currently undergoing development or which have recently been built. The project site itself is actually currently under construction. The site is being developed as an addition to the Biomed research facility to the north, which is a 7 story structure. Across Fairview to the west is a 12 story Shnitzer West office building which currently under construction. To the south, across Republican St, is a recently completed 14 story office building (400 Fairview).

There are also older and smaller buildings close by. Across the alleyway to the east is the Cafe Row House, which is a Cafe/Bar and sees a large number of visitors, particularly pedestrian traffic, throughout the day. It seems to fit in well with the neighborhood feel of the street and has an almost iconic expression with its gabled roofs. Across Fairview to the South East is an older, 1 story building which houses a pilates center.

DESIGN: URBAN CONTEXT

Community Engagement

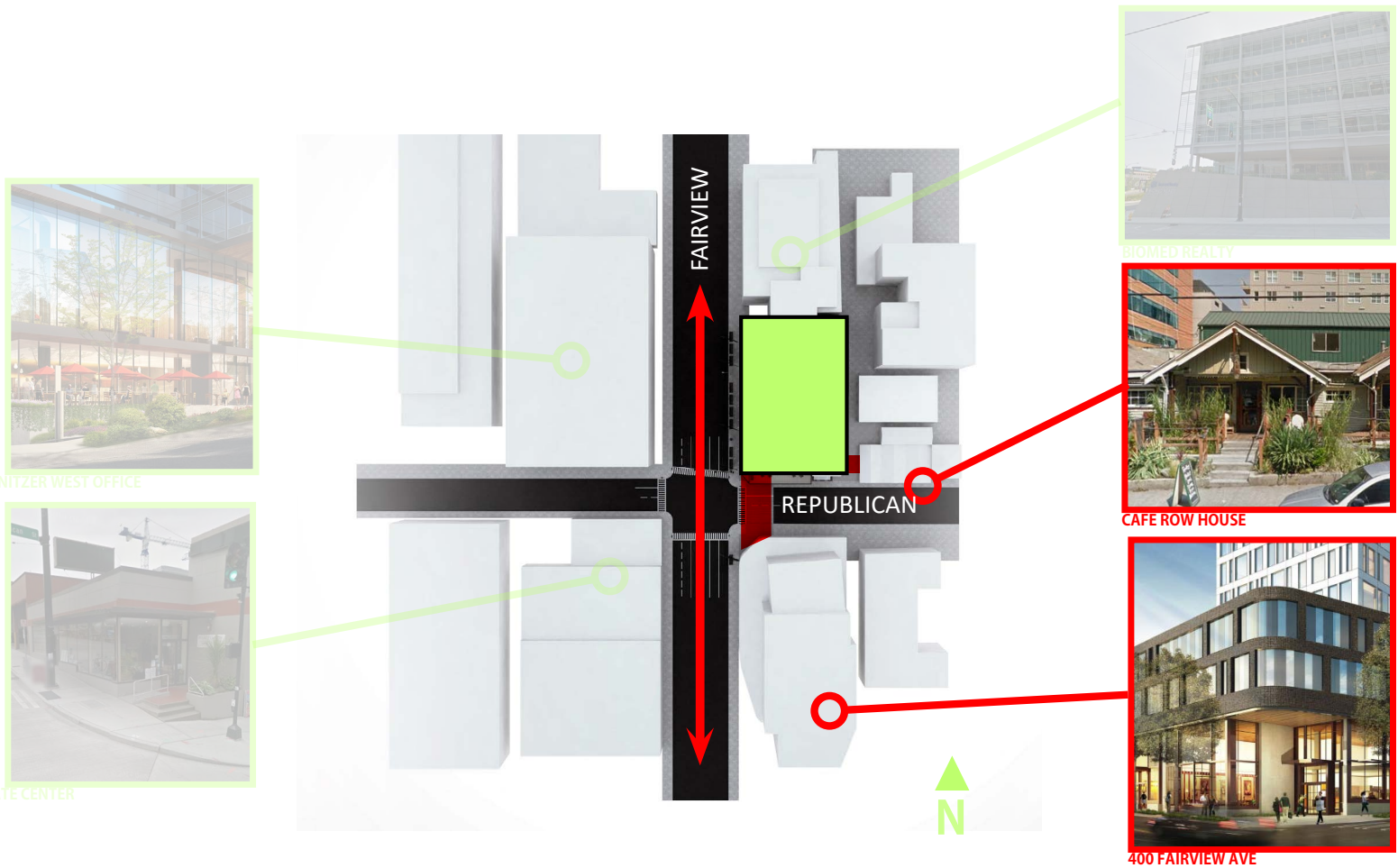

Because the site is just a block off of Mercer St., Fairview sees a lot of vehicular traffic and is generally a busy thoroughfare. The excess, fast moving traffic throughout the day turn Fairview, like Mercer St, into a barrier for pedestrian activity. Therefore, the best opportunities for developing or engaging pedestrians on the site would be to the East or South. By building some form of communication between the buildings, a more positive and pedestrian friendly environment can be created. While the building itself is meant as an office building for GSA use, the ground floor will be dedicated to commercial tenants, which can further stimulate pedestrian activity.

DESIGN: URBAN CONTEXT

Community Engagement

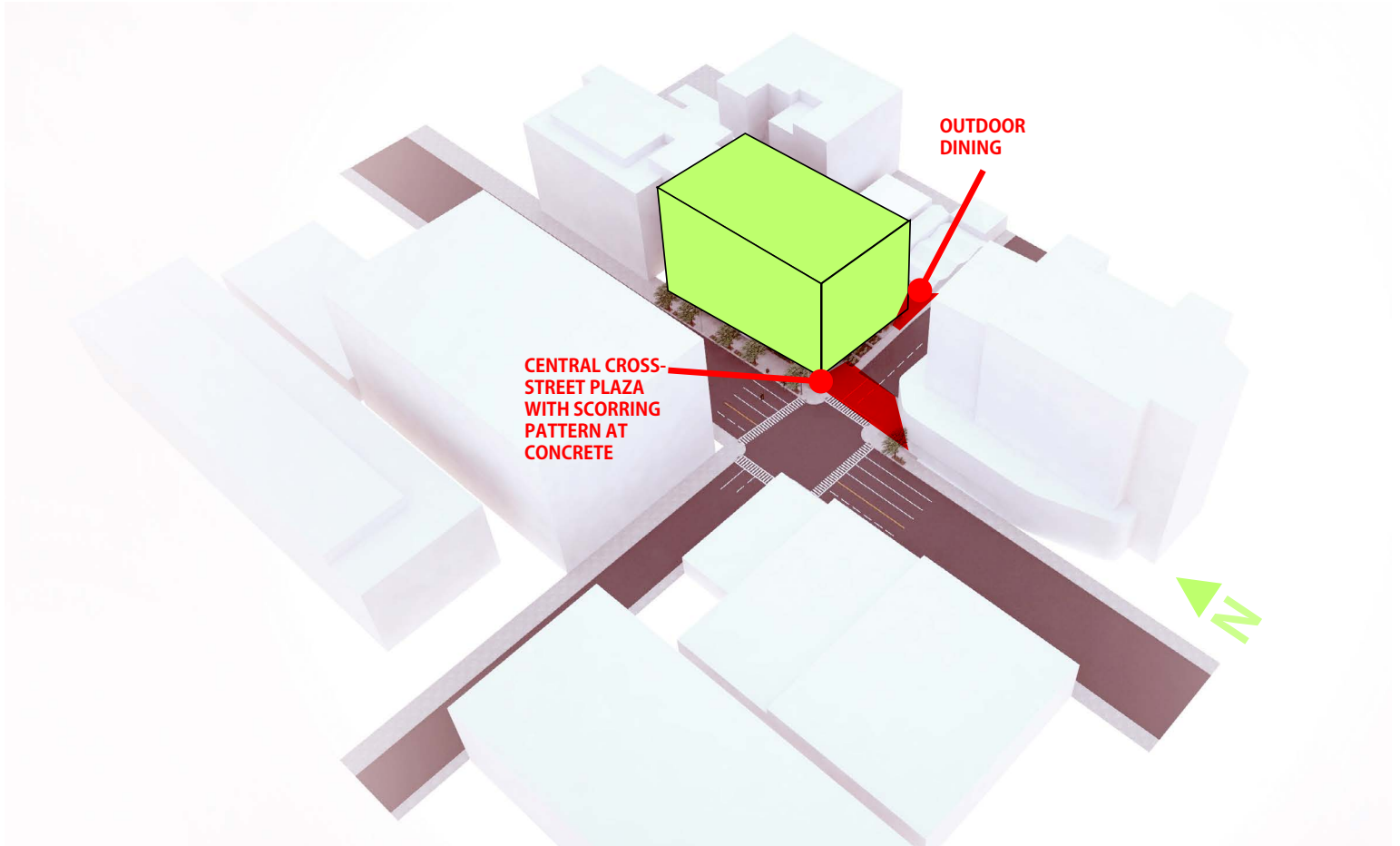

As an identified commercial and neighborhood zone, the form and program of the office building will engage the 400 Fairview project to the south and the Cafe Row House to the East. The public spaces between the buildings will be transformed into open air plazas that will produce an attractive and engaging atmosphere for pedestrian and community activity. The open air plazas between the building may also be engaged during open air markets and street events.

DESIGN: CODE COMPLIANCE

Building Code Limitations Analysis

TABLE 503
ALLOWABLE BUILDING HEIGHTS AND AREAS^{a, b}
 Building height limitations shown in feet above grade plane. Story limitations shown as stories above grade plane.
 Building area limitations shown in square feet, as determined by the definition of "Area, building," per story.

GROUP		TYPE OF CONSTRUCTION									
		TYPE I		TYPE II		TYPE III		TYPE IV	TYPE V		
		A	B	A	B	A	B	HT	A	B	
	HEIGHT (feet) ^c	UL	160	65	55	65	55	65	50	40	
		STORIES (S) AREA (A)									
A-1	S	UL	5	3	2	3	2	3	2	1	
	A	UL	UL	15,500	8,500	14,000	8,500	15,000	11,500	5,500	
A-2	S	UL	11	3	2	3	2	3	2	1	
	A	UL	UL	15,500	9,500	14,000	9,500	15,000	11,500	6,000	
A-3	S	UL	11	3	2	3	2	3	2	1	
	A	UL	UL	15,500	9,500	14,000	9,500	15,000	11,500	6,000	
A-4	S	UL	11	3	2	3	2	3	2	1	
	A	UL	UL	15,500	9,500	14,000	9,500	15,000	11,500	6,000	
A-5	S	UL	UL	UL	UL	UL	UL	UL	UL	UL	
	A	UL	UL	UL	UL	UL	UL	UL	UL	UL	
B	S	UL	11	5	3	5	3	5	3	2	
	A	UL	UL	37,500	23,000	28,500	19,000	36,000	18,000	9,000	
E	S	UL	5	3	2	3	2	3	1	1	
	A	UL	UL	26,500	14,500	23,500	14,500	25,500	18,500	9,500	

Type IB - Mid rise office building
 Non combustible materials
 up to **160 ft** of height
 up to **11 Stories**
 UL SF per floor

Type IV - Heavy Timber
 Non combustible exterior
 Combustible interior
 up to **65 ft** of height
 up to **5 Stories**
 UL SF per floor

For SI: 1 foot = 304.8 mm, 1 square foot = 0.0929 m².

A = building area per story, S = stories above grade plane, UL = Unlimited, NP = Not permitted.

a. See the following sections for general exceptions to Table 503:

1. Section 504.2, Allowable building height and story increase due to automatic sprinkler system installation.
2. Section 506.2, Allowable building area increase due to street frontage.
3. Section 506.3, Allowable building area increase due to automatic sprinkler system installation.
4. Section 507, Unlimited area buildings.

b. See Chapter 4 for specific exceptions to the allowable height and areas in Chapter 5.

c. A maximum of 12 inches of insulation may be added to the roof of an existing building without such additional height contributing to the *building height*.

Above is a chart that depicts the current building code limitations for wood structures. A mass timber building would be classified as a Type IV, combustible structure. As can be seen highlighted in green above, a Type IV structure is limited to 65 feet in height and no more than 5 stories. This makes it difficult to implement wood for larger structures, which dominate the construction scene in South Lake Union. For a similar building made out of non-combustible materials such as steel and concrete, the limitations on height and number of floors are minimal. Non-combustible construction is classified as Type I. As can be seen highlighted in blue, Type 1 construction for this particular application can extend up to 160' in height and up to 11 stories.

For the purposes of this thesis, it is assumed that the code will allow mass timber construction to have the same design freedoms as Type I construction buildings. However, alternatives that may require covering the wood and providing a topping slab will also be considered.

DESIGN: CODE COMPLIANCE

Setbacks

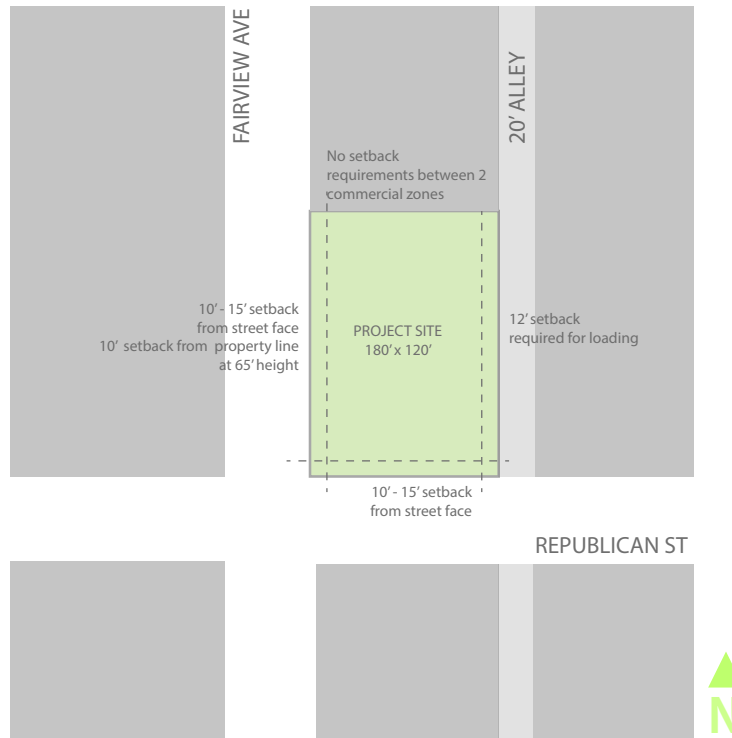

The diagrams above depict some setback requirements required on the property. A 10-15' setback is required off the face of the street to the building, and a 10' setback is required off of Fairview at 65' of height from the property line. At the alley, a 12' setback is required for loading. As mentioned in previous chapters, the site is located in a Seattle Mixed (SM) zone, where a commercial building is allowed to reach up to 160' in height. The SM zone designation indicates that more than one use can be contained in a single building. In fact, the South Lake union zoning encourages diverse uses in a single building.

DESIGN: CODE COMPLIANCE

FAR

Building Breakdown:

- Below Grade Parking

$$P2 = 180 * 120 = 21,600 \text{ SF}$$

$$P1 = 180 * 120 = \underline{21,600 \text{ SF}}$$

43,200 SF

Not included in FAR

- Ground Level (Commercial & BOH)

$$\text{Commercial \& Lobby} = 165 * 98 = 16,170 \text{ SF}$$

Not included in FAR

- Upper Levels (Office Space)

FAR requirement is 5

$$\text{Upper Levels} = 165 * 98 = 16,170 \text{ SF}$$

$$\text{Site} = 180 * 120 = 21,600 \text{ SF}$$

$$21,600 \text{ SF} * 5 = 108,000$$

$$108,000 / 16,170 = \mathbf{6.68 \text{ Levels above Ground}}$$

6 levels total above

ground

$$\mathbf{- \text{Height} = (20 \text{ Ground floor}) + (6 \text{ office} * 14 \text{ feet}) = 104 \text{ ft}}$$

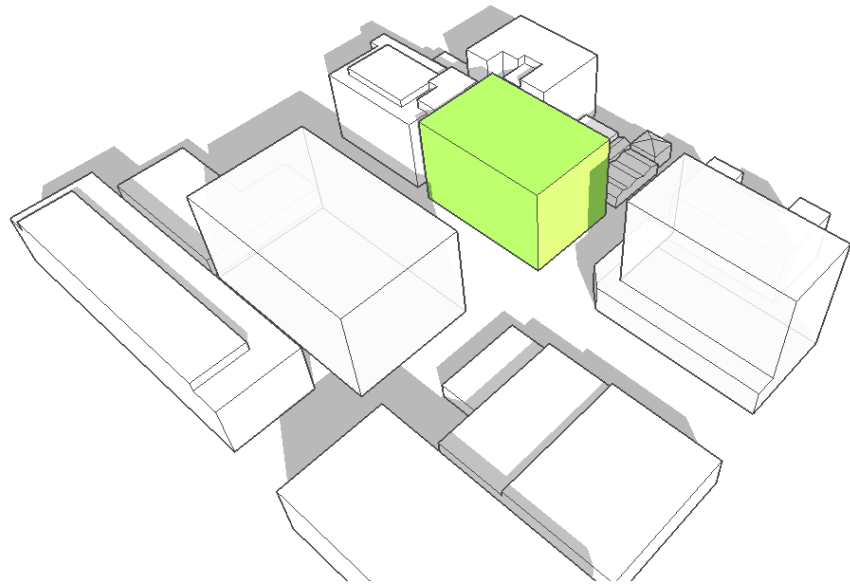

Shown above are calculations that show how the base FAR impacts the size and massing of the project. The base FAR (Floor Area Ratio) is 5 for South Lake Union. If you take the square footage of the property and multiply it by 5, you get the total square footage that can be developed on the site. The South Lake Union does not consider commercial tenant space as part of the FAR requirements, which allows for greater diversity and development height. At the beginning, a choice had to be made as to whether to try to get the maximum number of stories or to take up more of the site. Maximizing the height of the building ultimately led to much smaller floor plates, which did not allow for a large enough space for an open plan office building per floor (much of the floor plate was taken up by the core). Building up also left a lot of dead space on the site, which would have been difficult to develop because the property does not receive a large amount of sunlight.

Instead, the decision was made to develop the site by taking up as much of the property at the footprint as possible. This led to 6 floors total of development potential for the open plan office building. The building also includes 2 levels of parking below grade, which is not considered a part of the FAR requirements and 1 story at grade that will be dedicated commercial space. This commercial space is also not considered a part of the FAR. Therefore, the total building is 2 stories below grade parking and 7 stories above grade. The first floor at grade is 20' in height, which is recommended by the South Lake Union urban design guidelines and the second-seventh floors are 14' floor to floor. The total height of the building, given these constraints is 104' above grade. The core projects above the seventh floor to roof access an additional 10', but this penthouse projection is typically not limited by building height zoning. Regardless, the maximum allowable height for the property is 160', and the building is well below that requirement.

DESIGN: CODE COMPLIANCE

Form Development - Setbacks

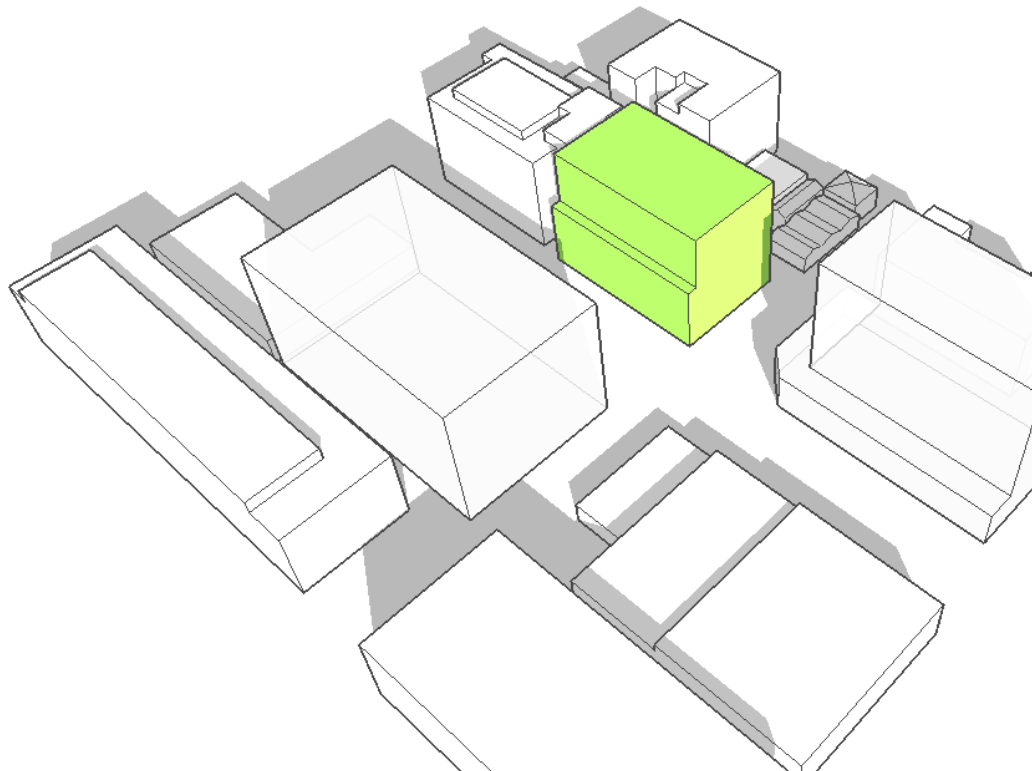
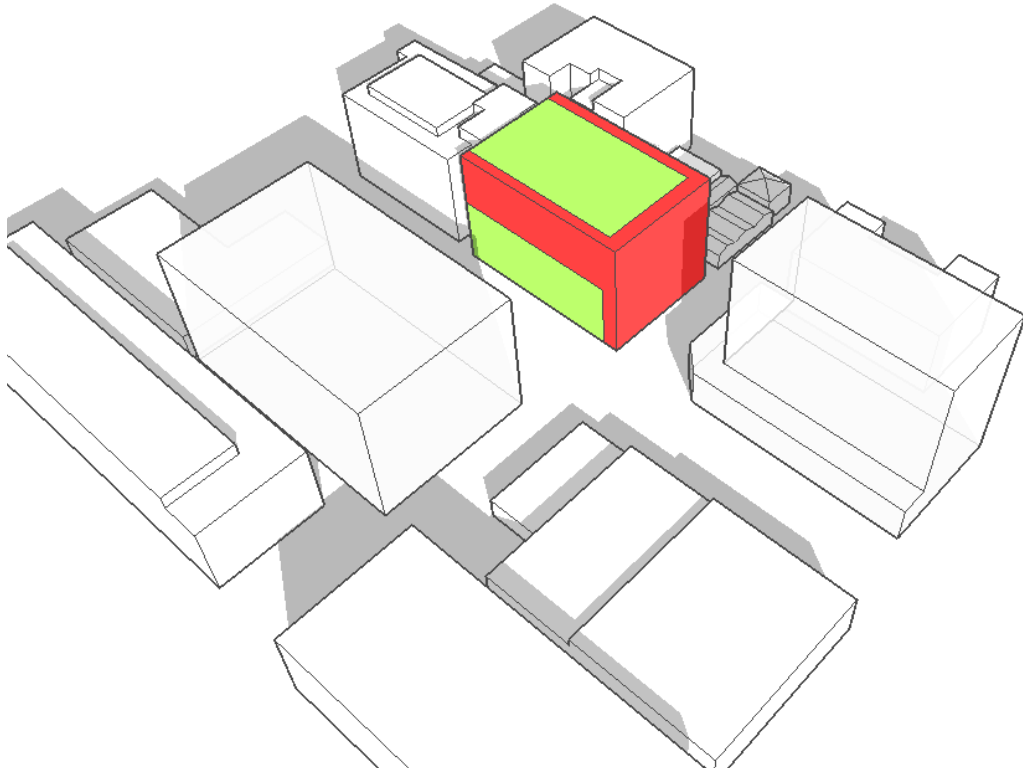

The images above show the form the building takes once zoning and setback requirements are implemented.

DESIGN: CODE COMPLIANCE

Form Development - Entry & Core

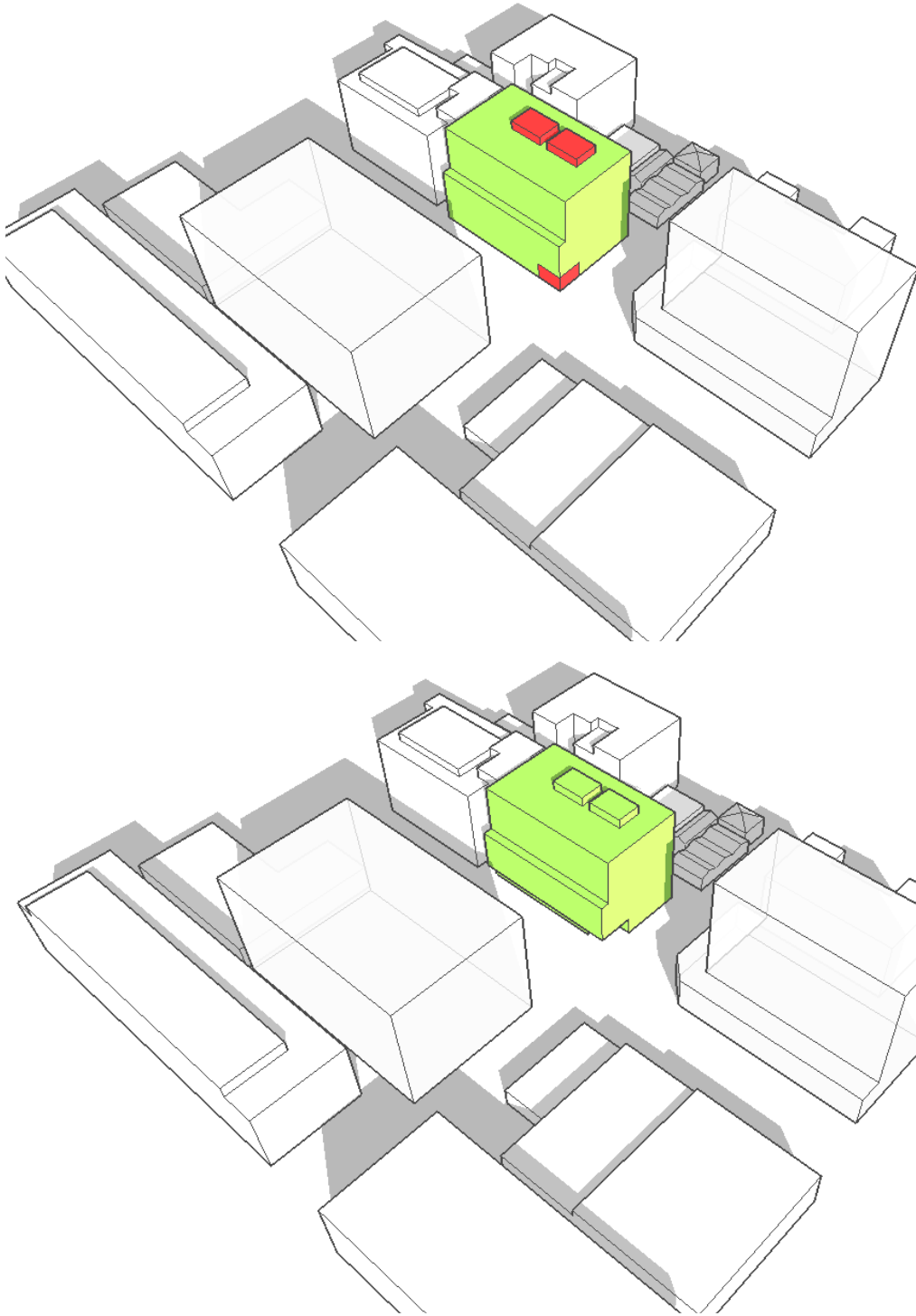

Some other form shaping requirements are shown being applied to the property in the images above. These include the building entry and centralized cores. The rest of the building design will have to be constrained by these general shape requirements.

DESIGN: BUILDING DIAGRAMS

Building Massing Study

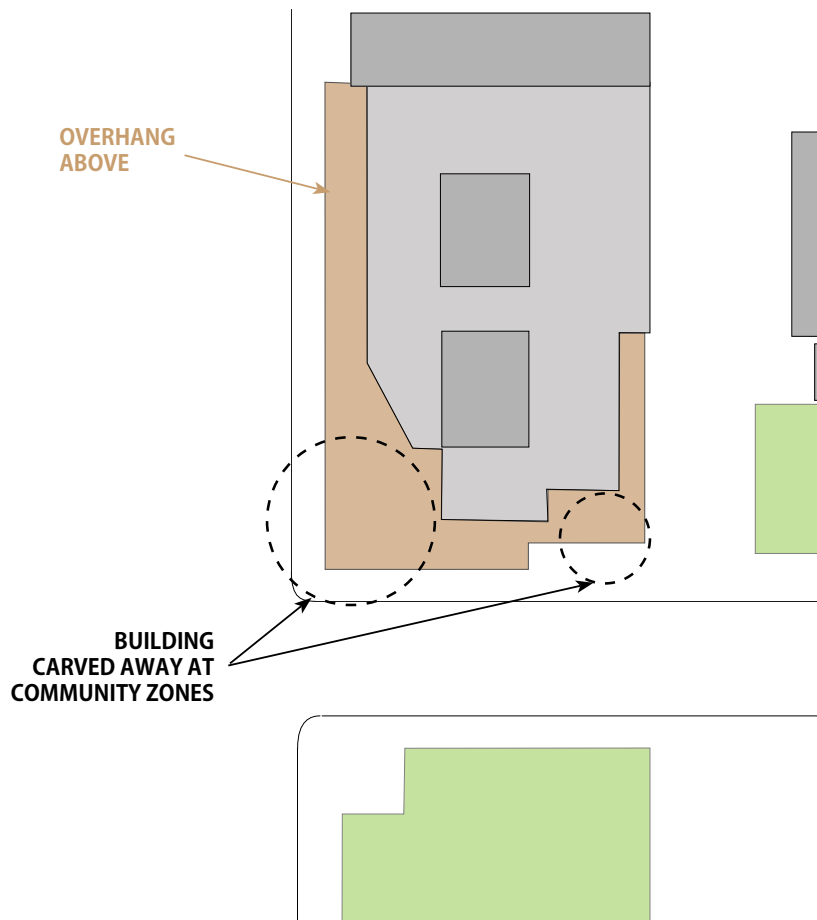

The commercial floor at grade has the most impact on the pedestrian environment at the property and street corner. The building engages the neighbors to the East and South by carving away at the ground plane, blending exterior and interior to create semi-public, open air plazas. The building above provides some cover from rain, creating a place of pedestrian activity throughout the year. The two circles shown in the diagram above are the activated zones, where the ground floor plan has been pulled back the most as an acknowledgement to the surrounding neighbors.

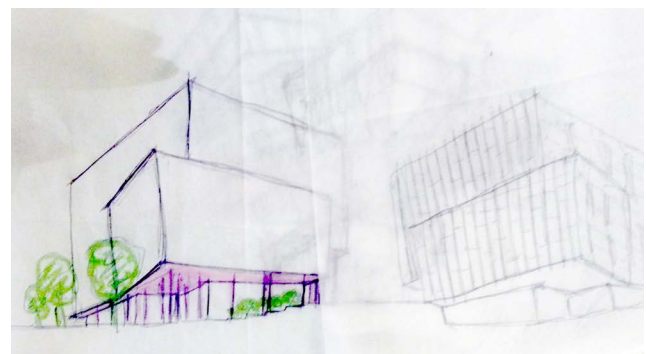
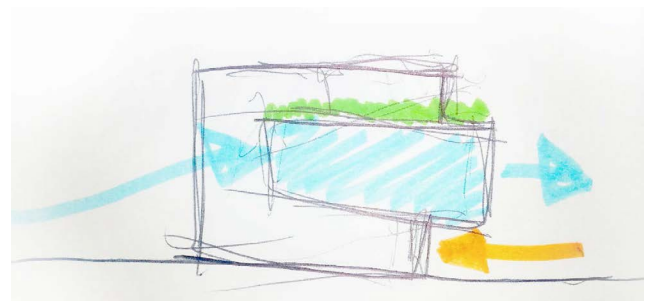

DESIGN: BUILDING DIAGRAMS

Process Models & Sketches

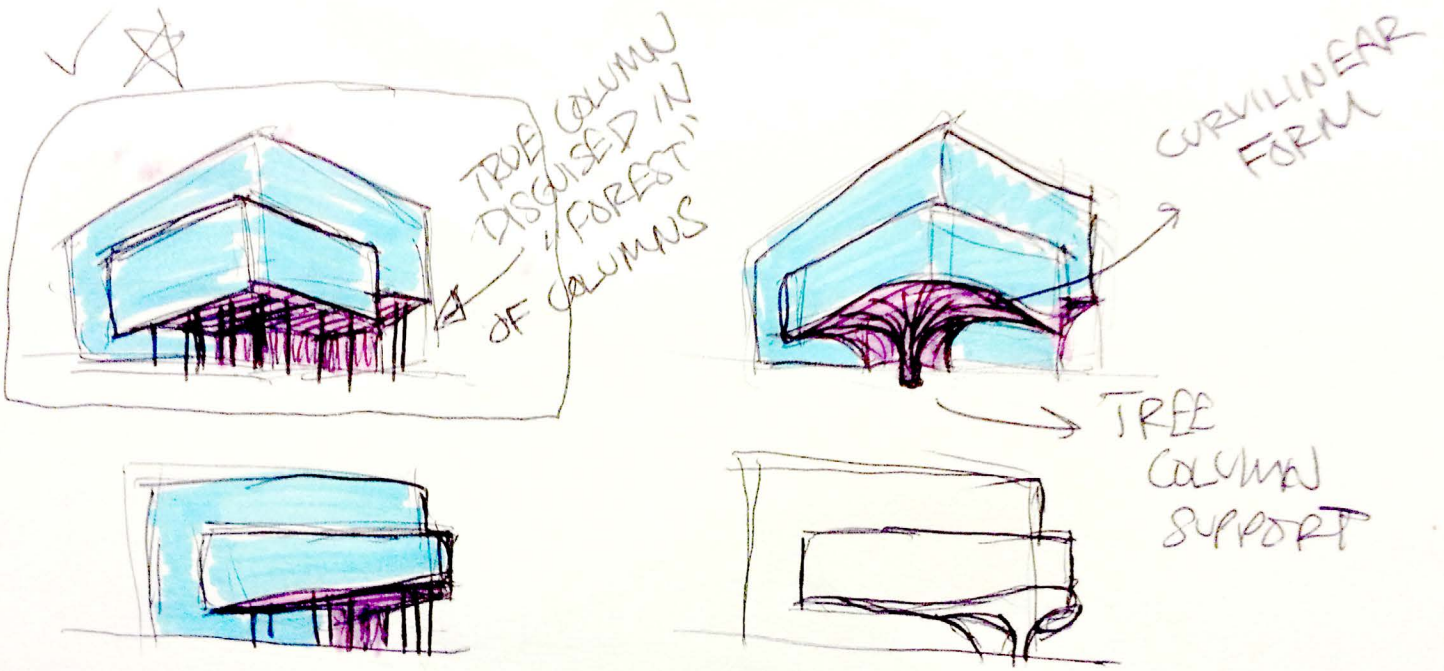

The expression of the overhang at the ground floor plane was an area of extensive exploration for the feel and expression that the building provides. The building overhangs in both directions at the corner, which required a column to post down in this area structurally. While there were several ways to structurally remove the column, some time was spent coming up with ways to glorify or disguise the column (shown above). Ultimately, the decision was made to disguise the column in a forest of false columns. This expression at the ground floor plane became a concept about a natural forest in an otherwise dense urban environment.

The location, spacing and arrangement of the false columns can create a series of micro spaces under the overhangs, which could generate more activity and engagement with the surrounding community and visiting pedestrians.

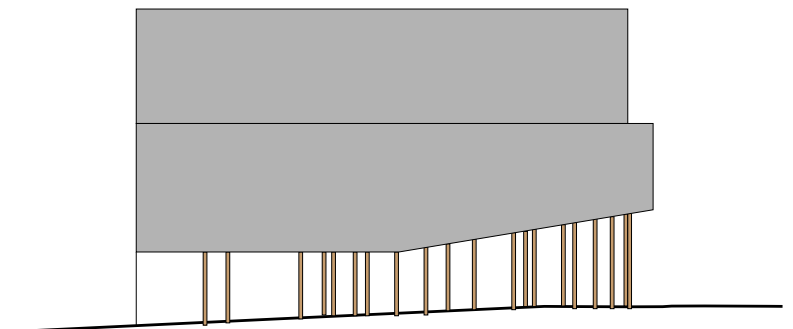
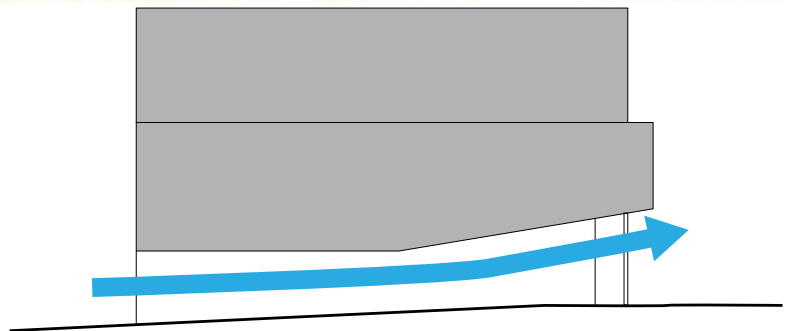

DESIGN: BUILDING DIAGRAMS

Building Massing Study

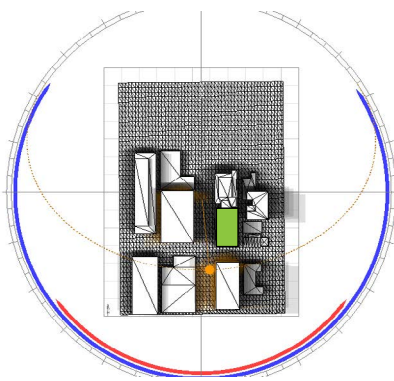

JUNE 21st at noon

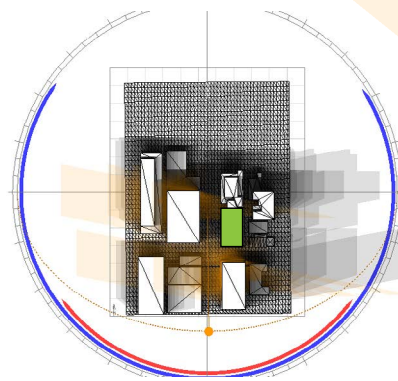

SEP/MAR 21st

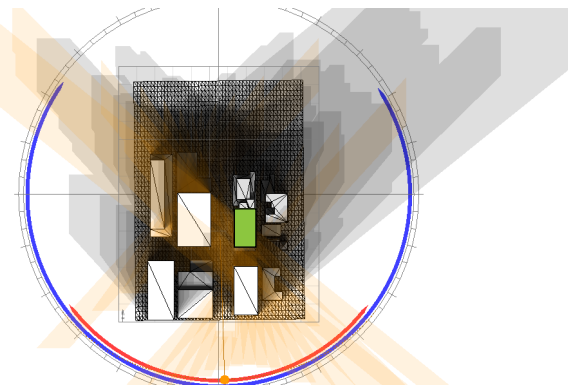

DECEMBER 21st

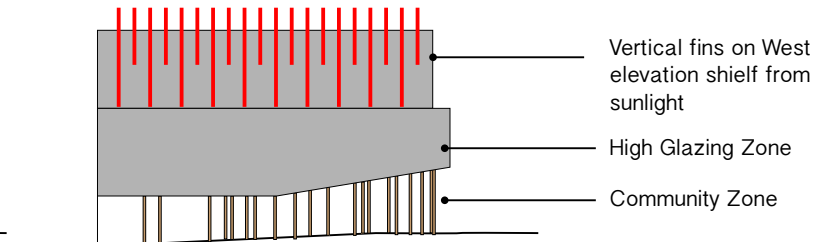
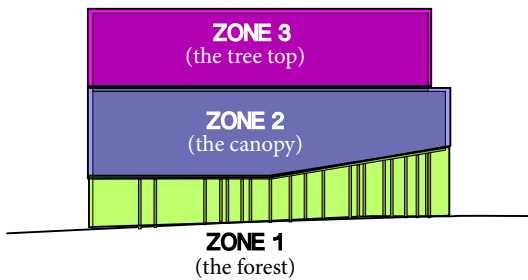
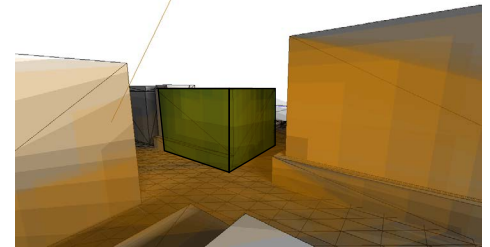
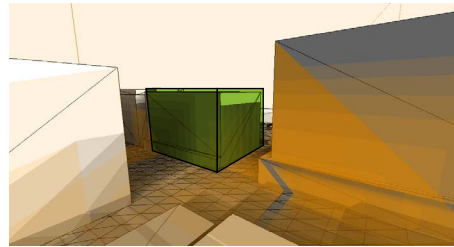
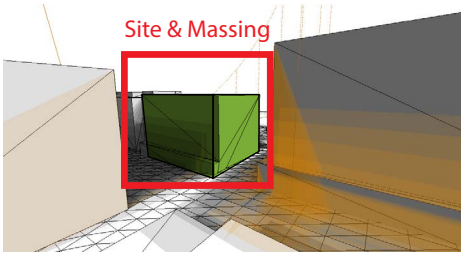

The open plan office spaces above the ground floor plane also required some design development. In order to analyze the needs of this space, sun angles and shading studies were done on a simplified massing of the property to determine facade shading requirements. These studies included adjoining buildings at full development height. Because the surrounding buildings are fairly tall, much of the lower half of the open plan office space remains shaded throughout the year. The upper portion, however, does require some shading. In order to provide shading at the upper portion of the building, vertical fins were implemented, especially at the longer western side of the building, where evening sun is undesirable. The image to the right depicts a quick massing model done of the building.



DESIGN: BUILDING DIAGRAMS

Paths, Streams, Stones & Clearings

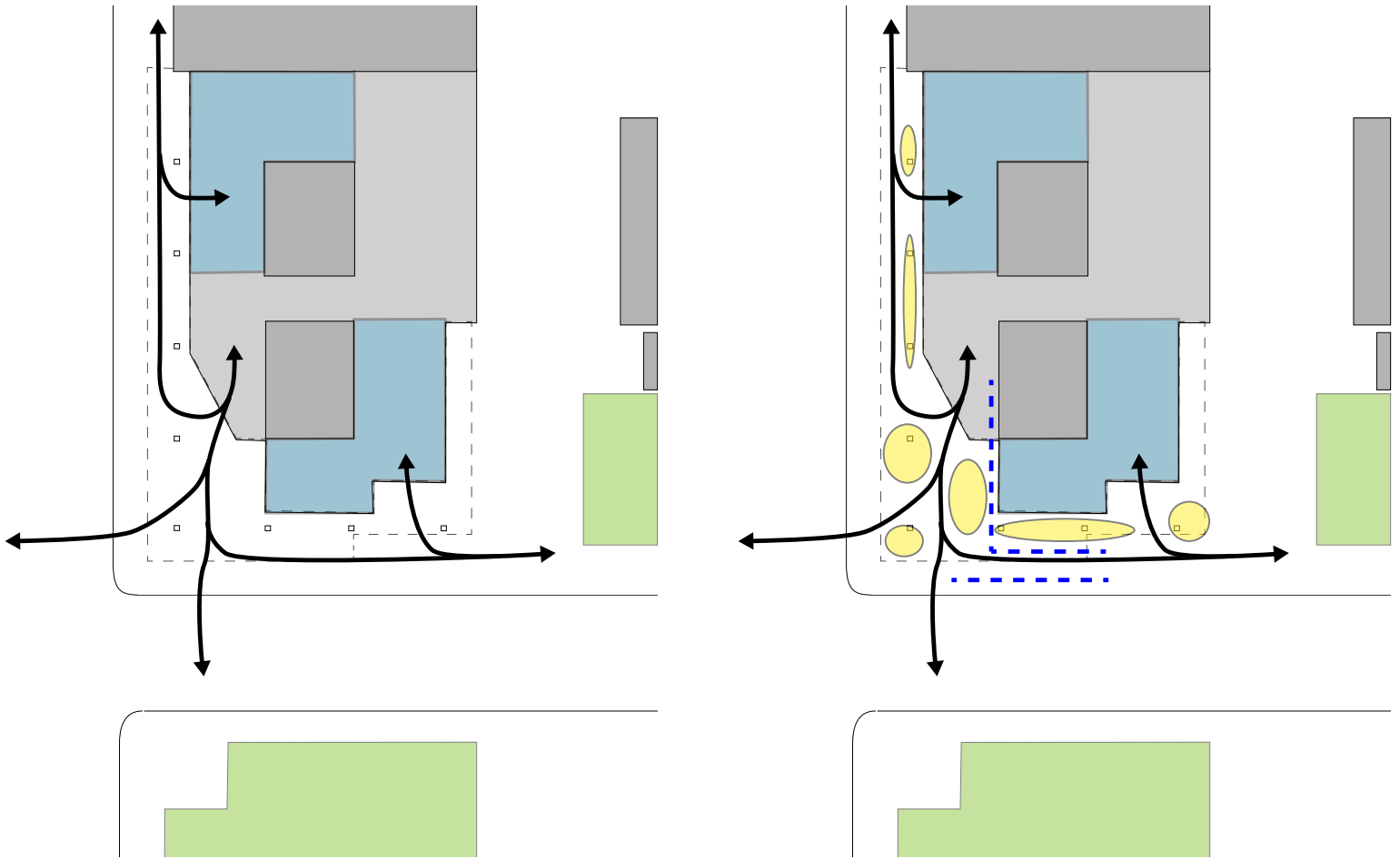

The configuration of the false columns and other exterior elements arose from the concept of the ground plane as a natural forest. In this instance, the natural forest is presumed to contain stones, trees, trails and streams. The trails create clearings through the forest to guide pedestrians to the important building entry points while the areas directly surrounding the trails receive a greater density of false columns. At the southern edge of the site, there is a fairly significant 7 foot grade drop. This grade drop provided an opportunity for water filtration using the gravity differential present in this locations. The water filtration system, or stream, lines either side of the trail (see dotted blue line in upper right corner). The areas shown in blue above indicate commercial areas. The other grey areas at ground level indicate the main building entry lobby at the South-West corner and the loading dock and back of house function at the North-East corner of the building.

DESIGN: BUILDING DIAGRAMS

Ground Level Plan - Diagrammatic

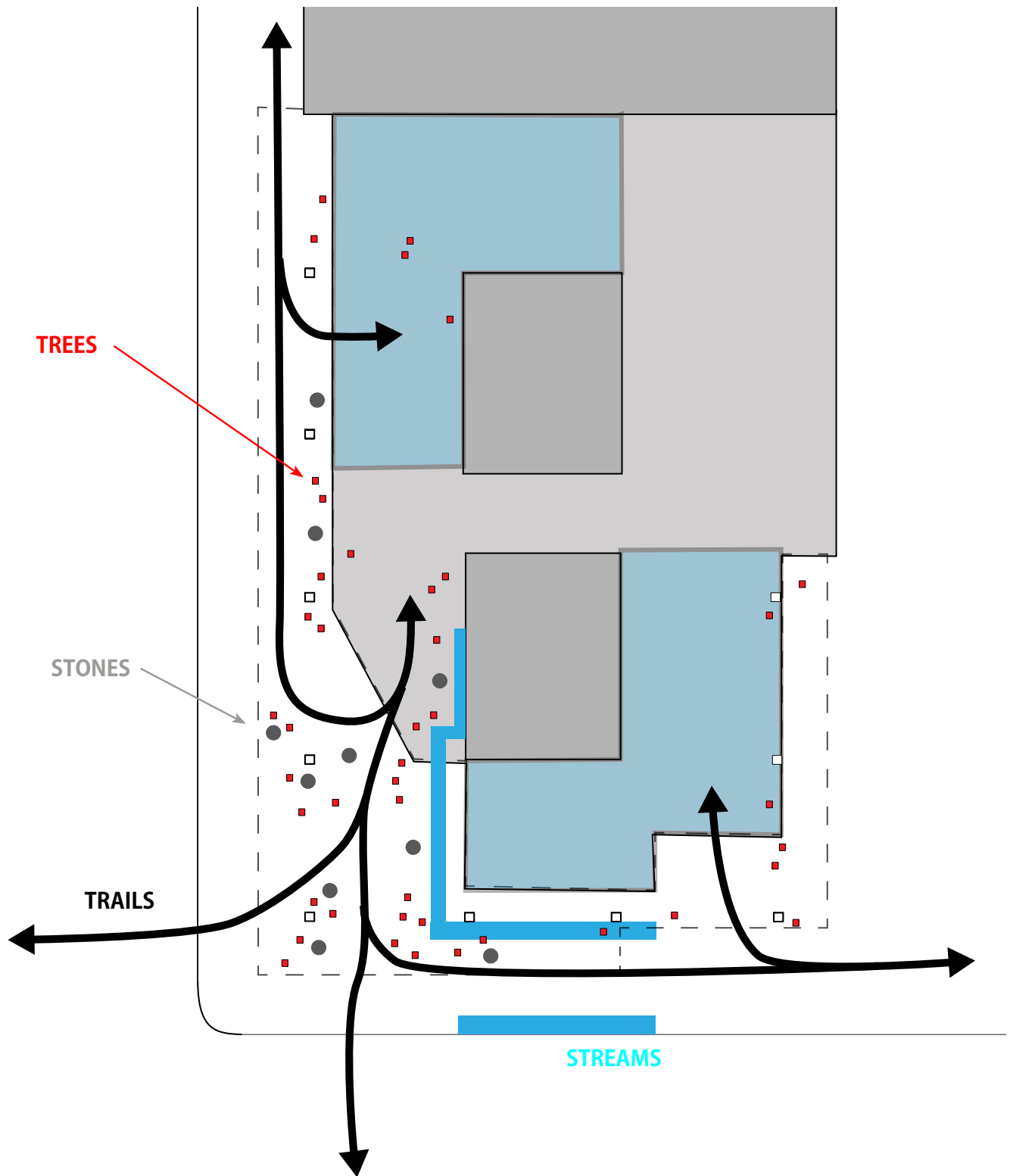

Above is the final configuration of the trails (clearings), trees (false columns shown in red), stones and streams.

DESIGN: FLOOR PLANS + SECTIONS

P2



The following images will show the building floor plans, as developed based on a typical 30' x 30' structural grid.

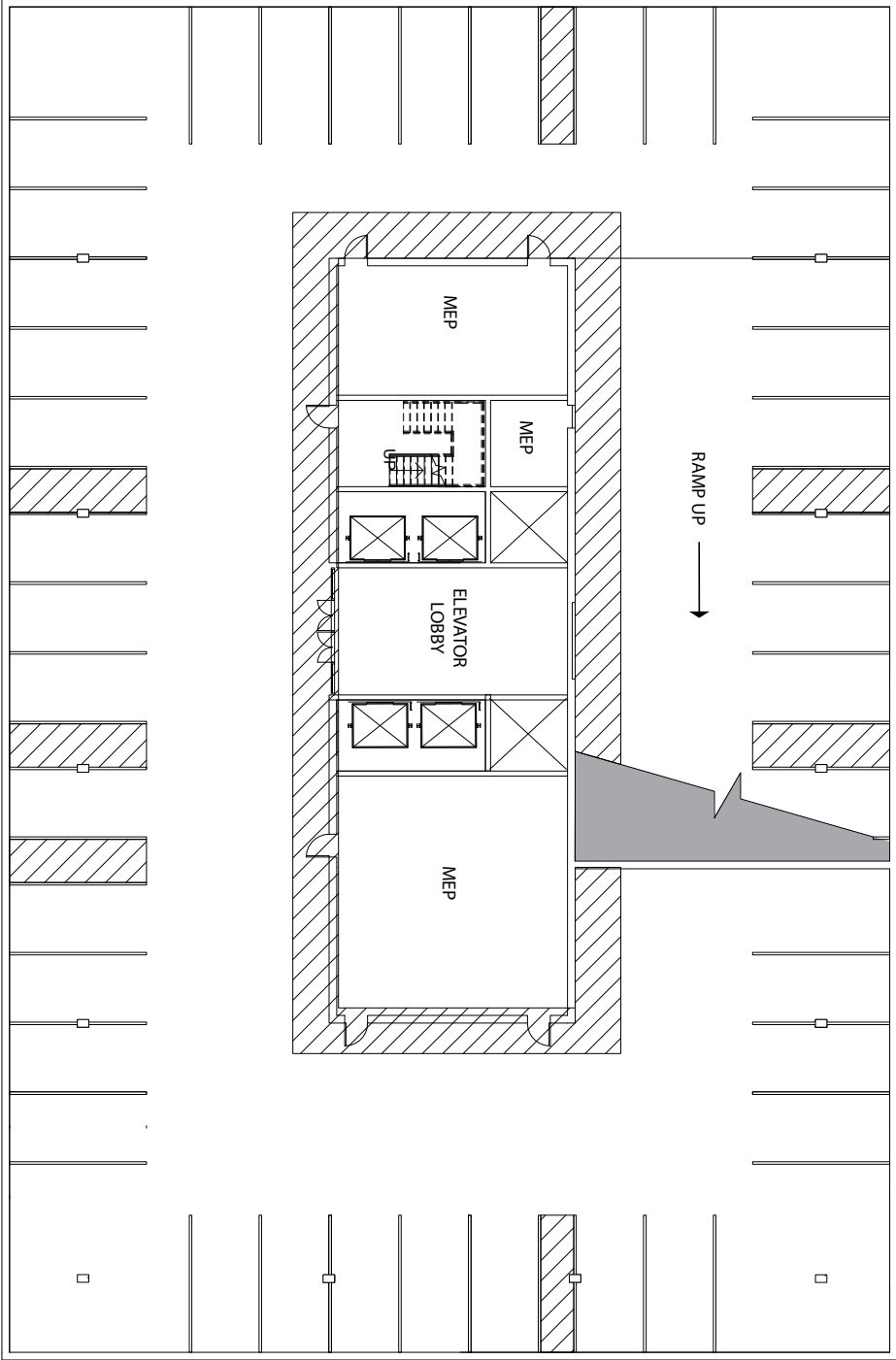

DESIGN: FLOOR PLANS + SECTIONS

P1

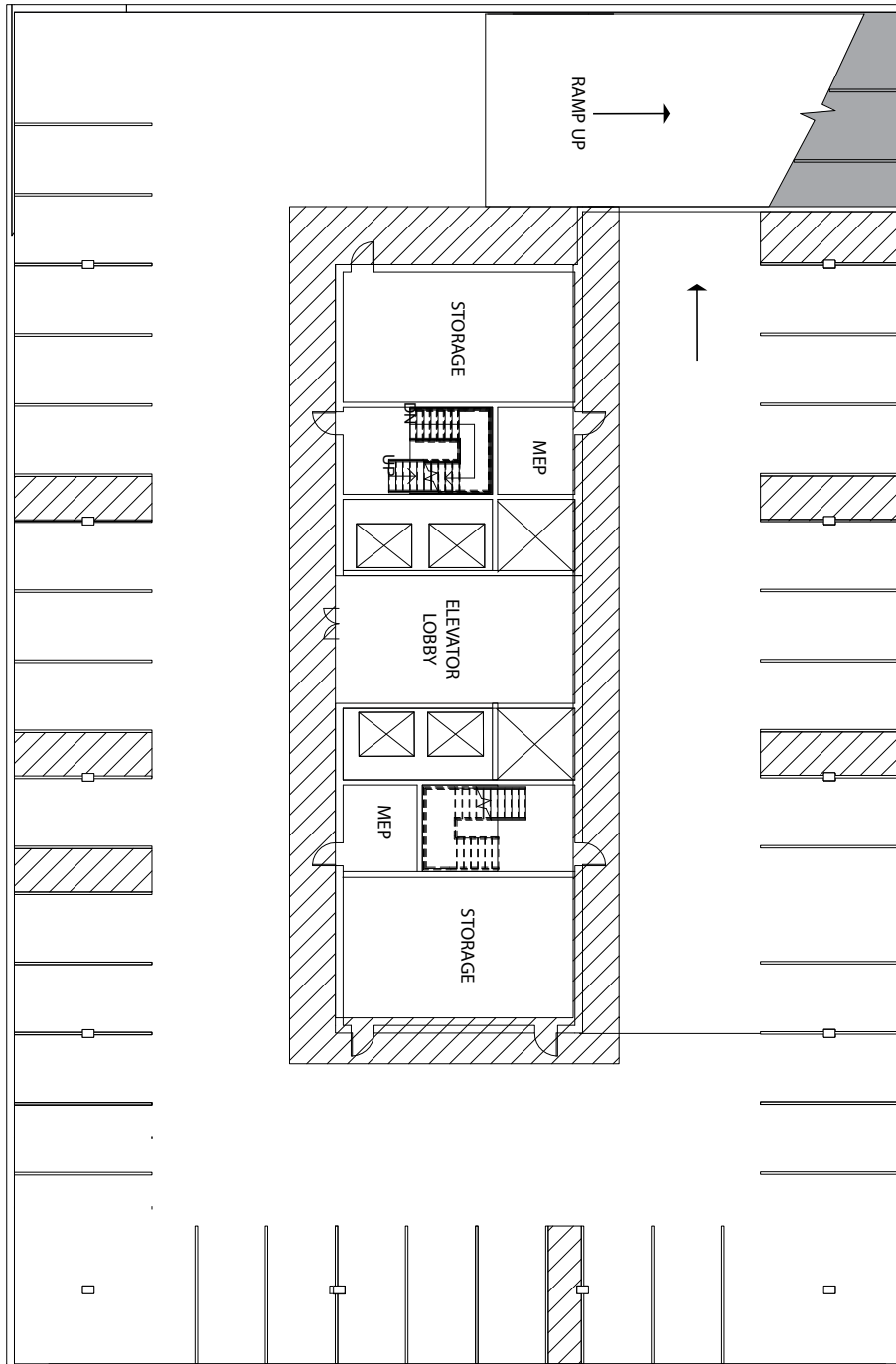

DESIGN: FLOOR PLANS + SECTIONS

Ground Floor Plan

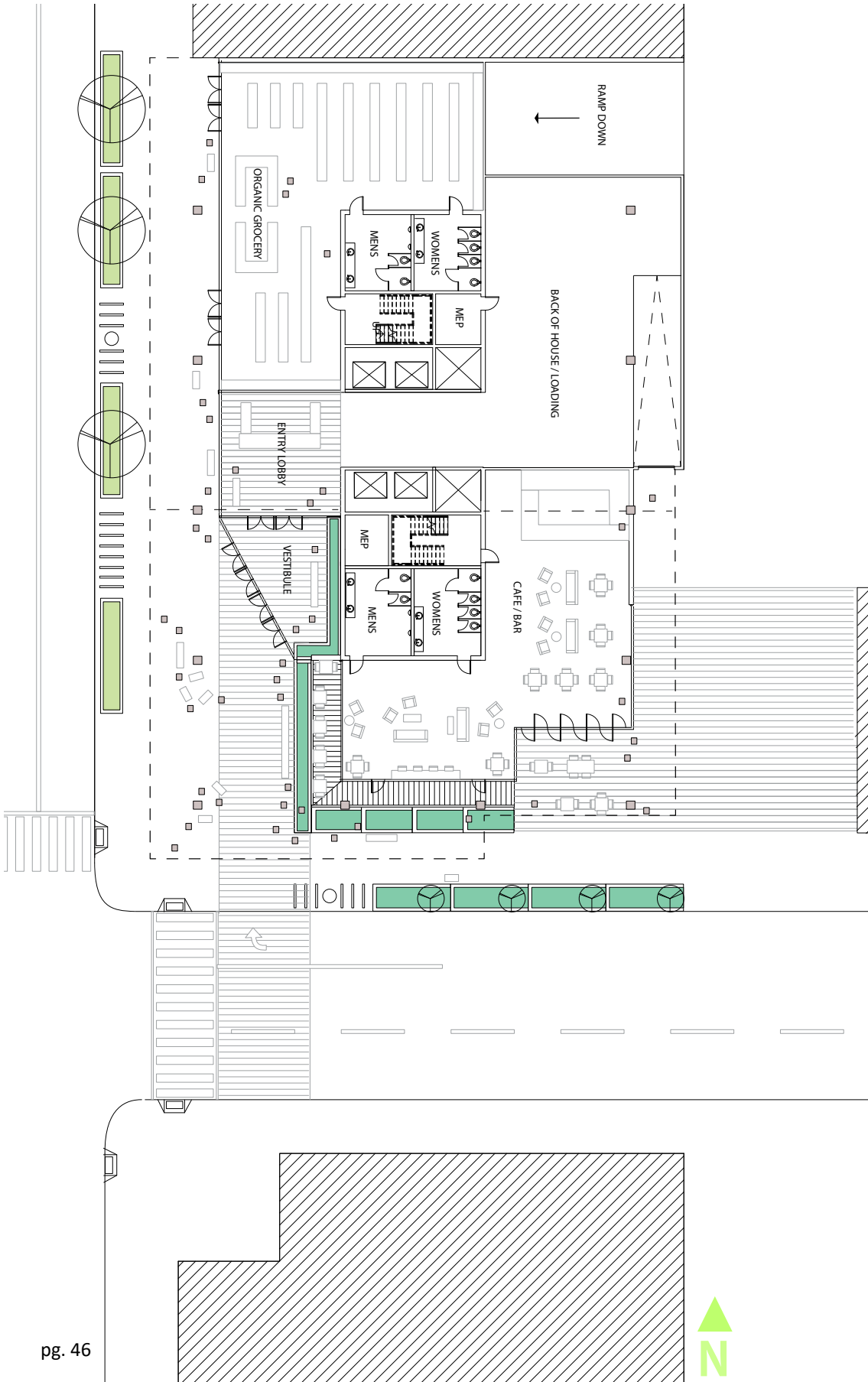

DESIGN: FLOOR PLANS + SECTIONS

Level 2

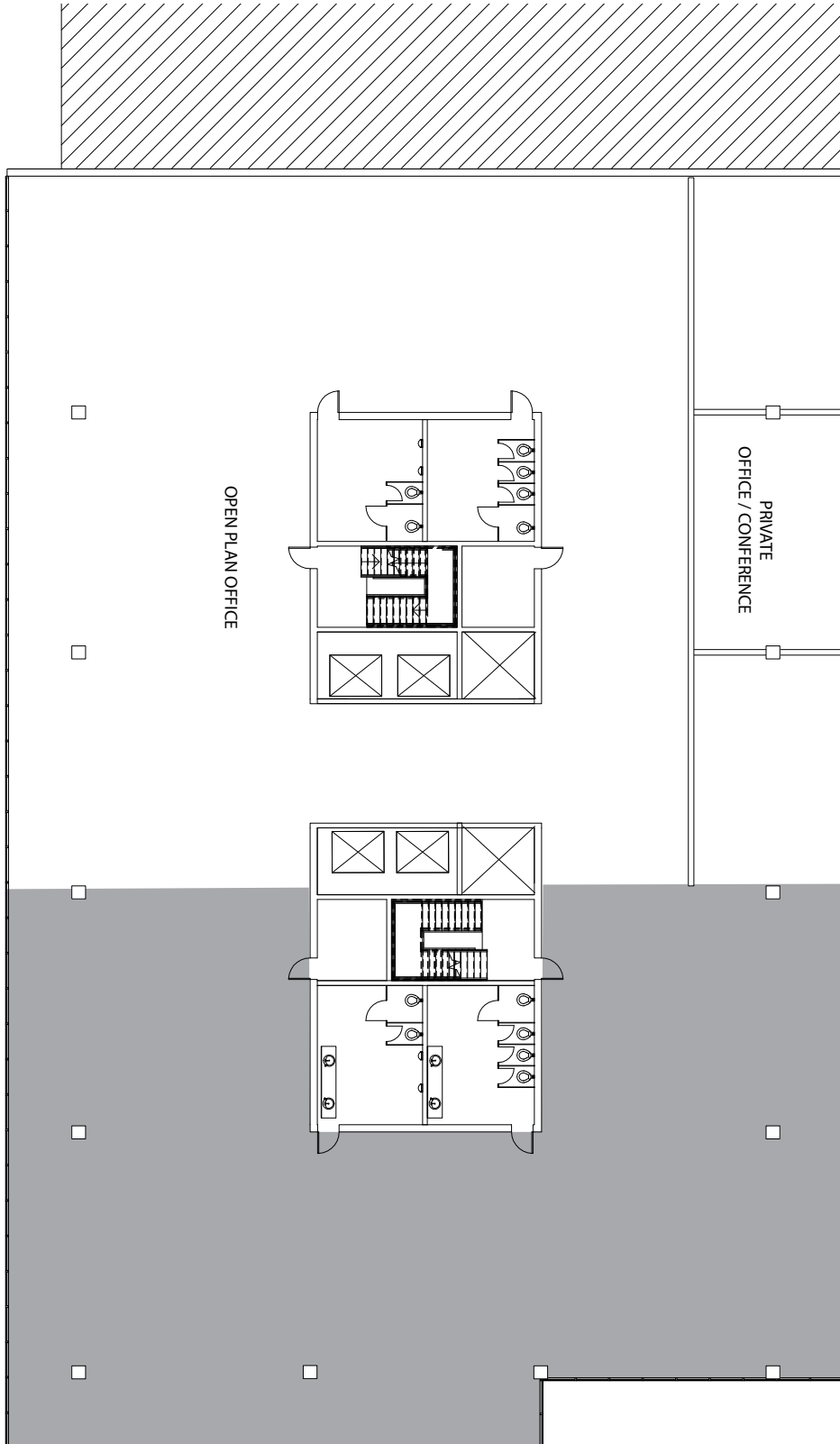

DESIGN: FLOOR PLANS + SECTIONS

LEVELS 3 & 4

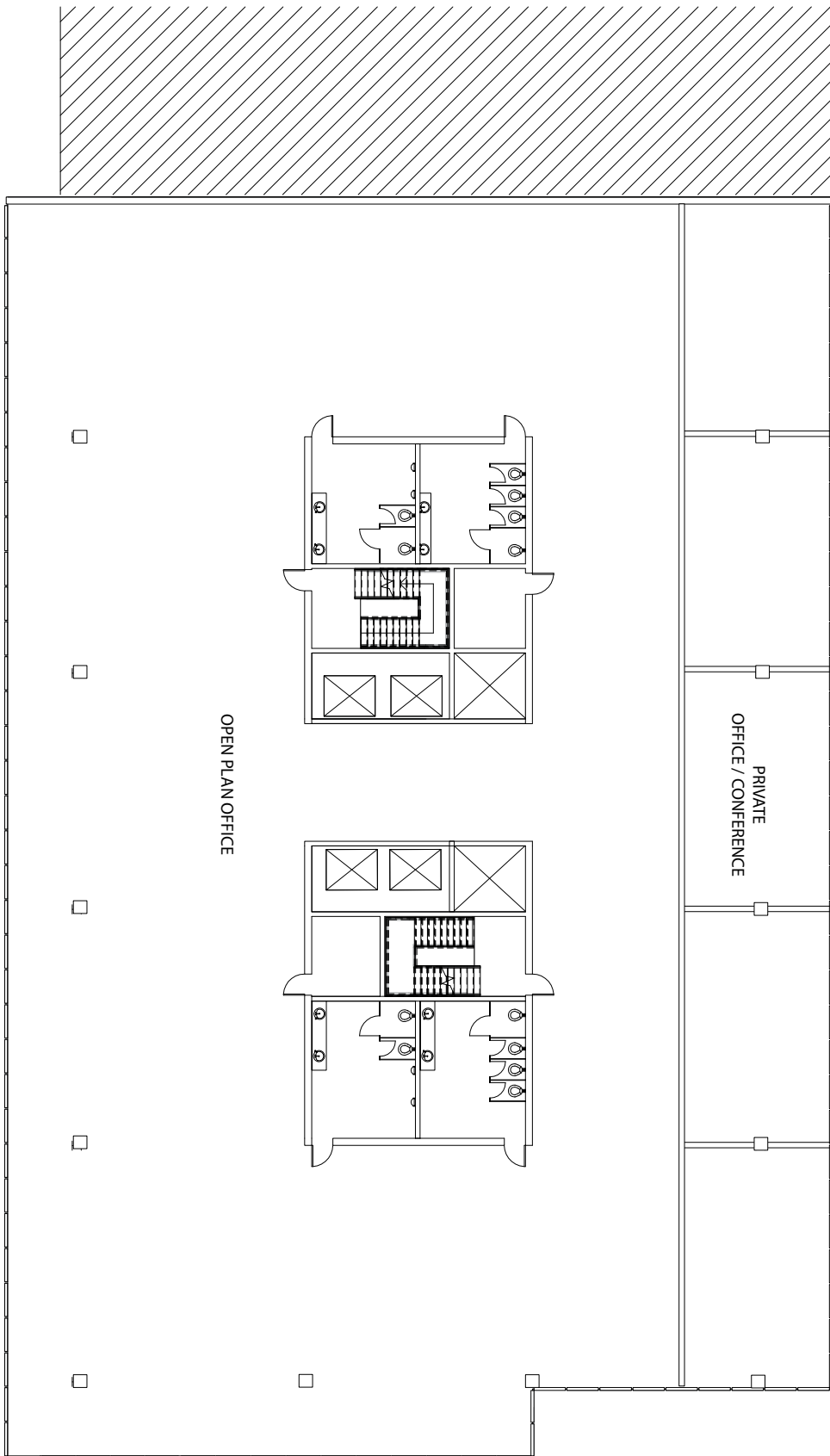

DESIGN: FLOOR PLANS + SECTIONS

Level 5

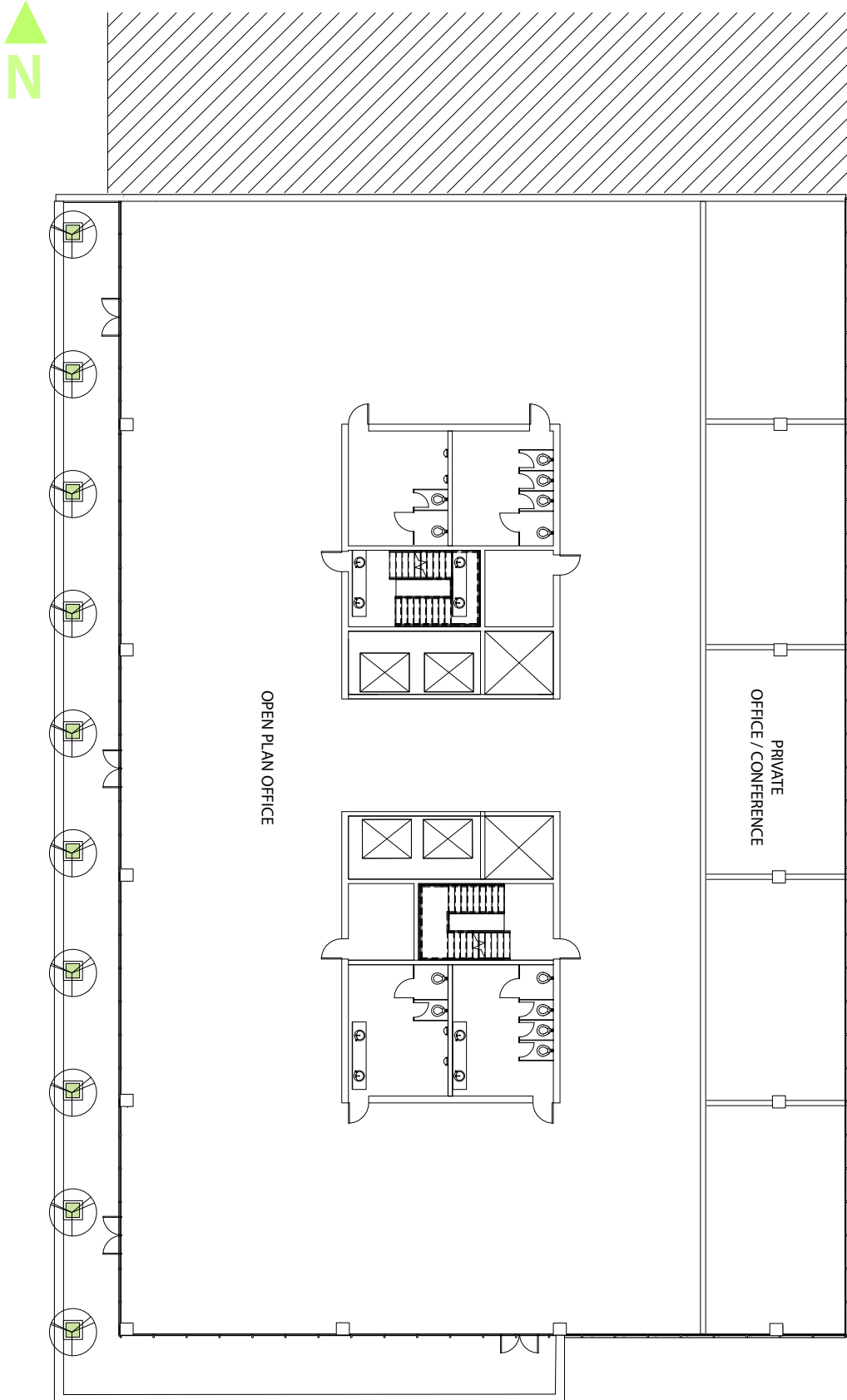

DESIGN: FLOOR PLANS + SECTIONS

Level 6 & 7

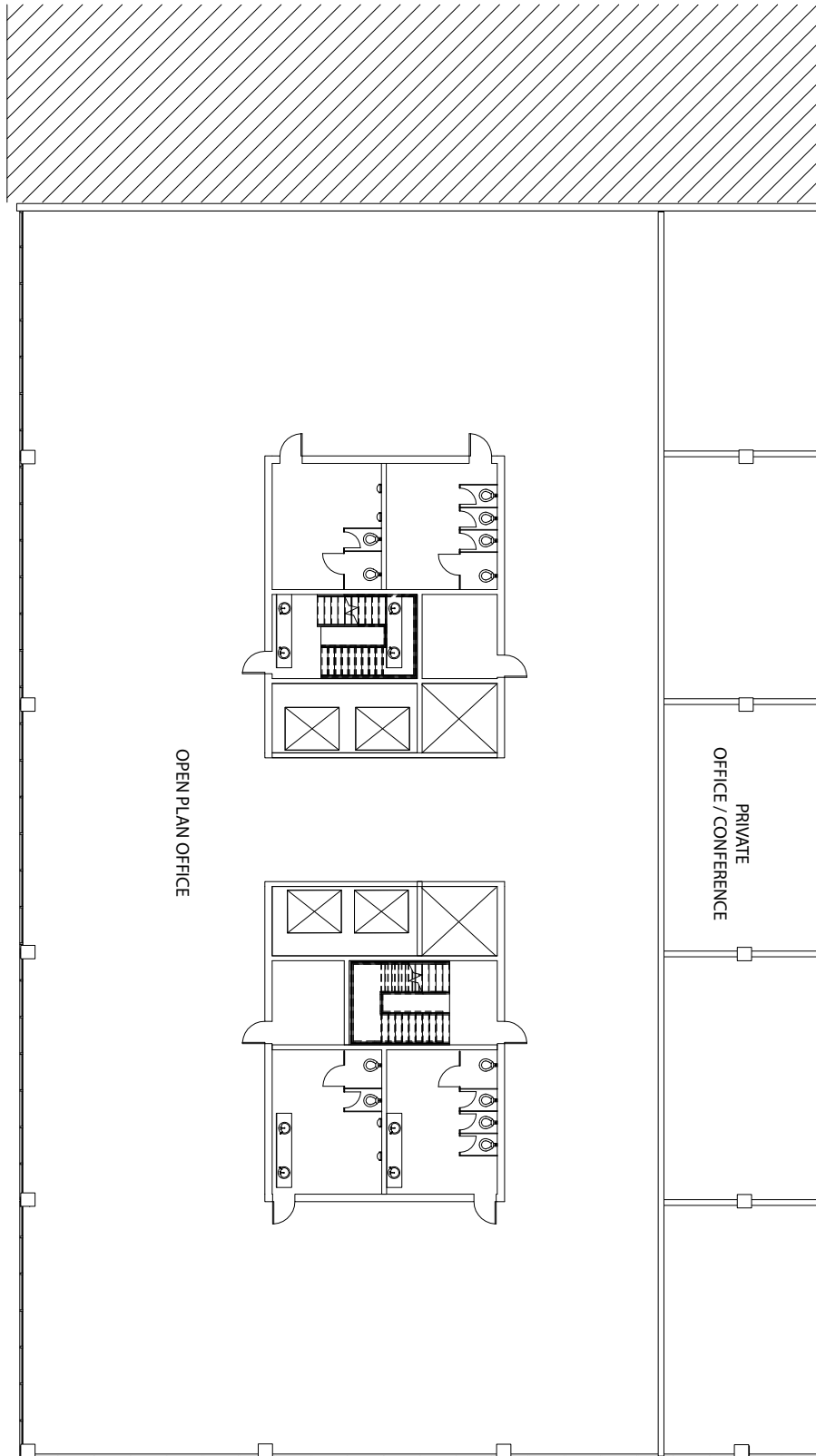

DESIGN: FLOOR PLANS + SECTIONS

Roof Level

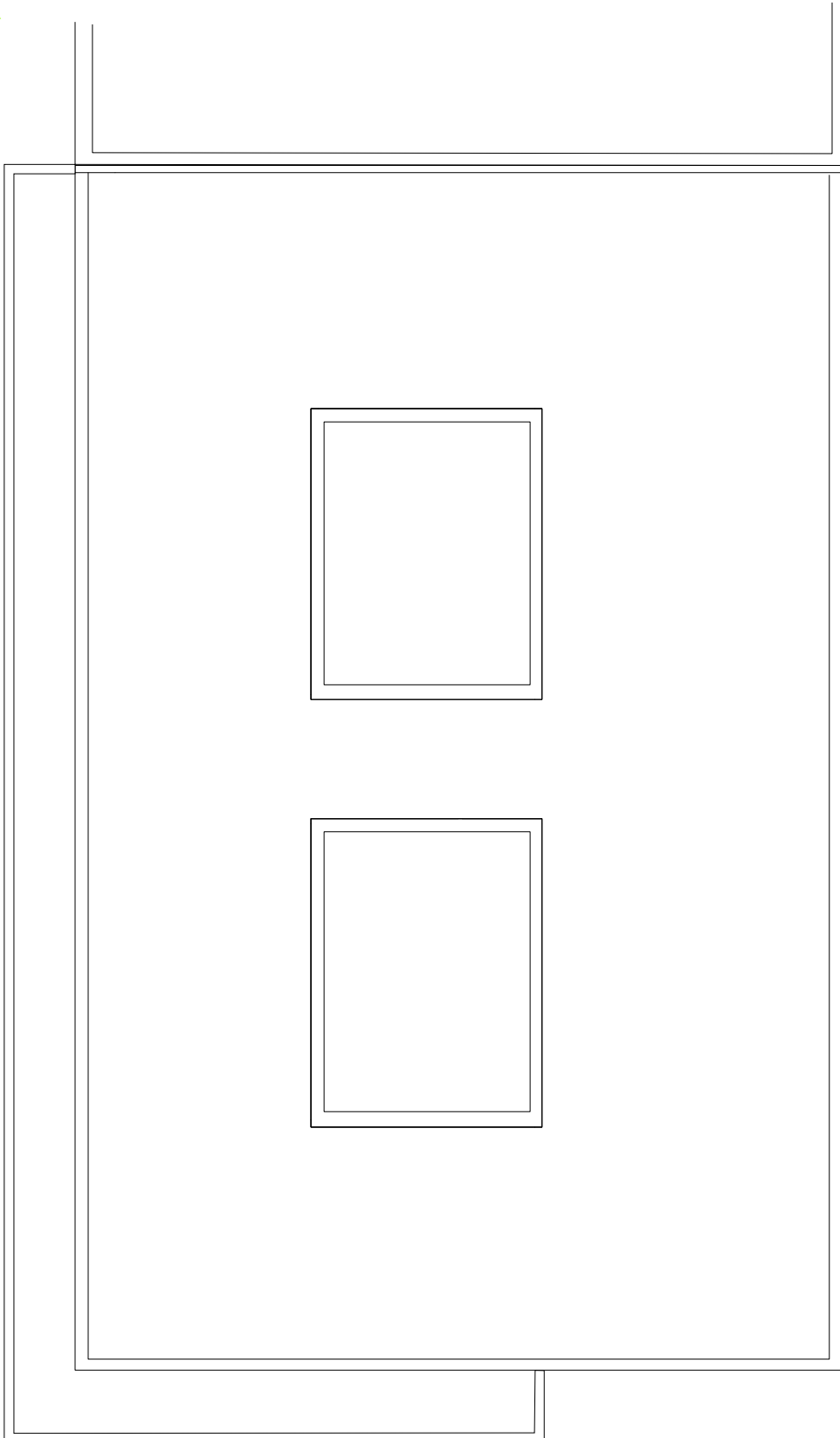

DESIGN: FLOOR PLANS + SECTIONS

Longitudinal Section

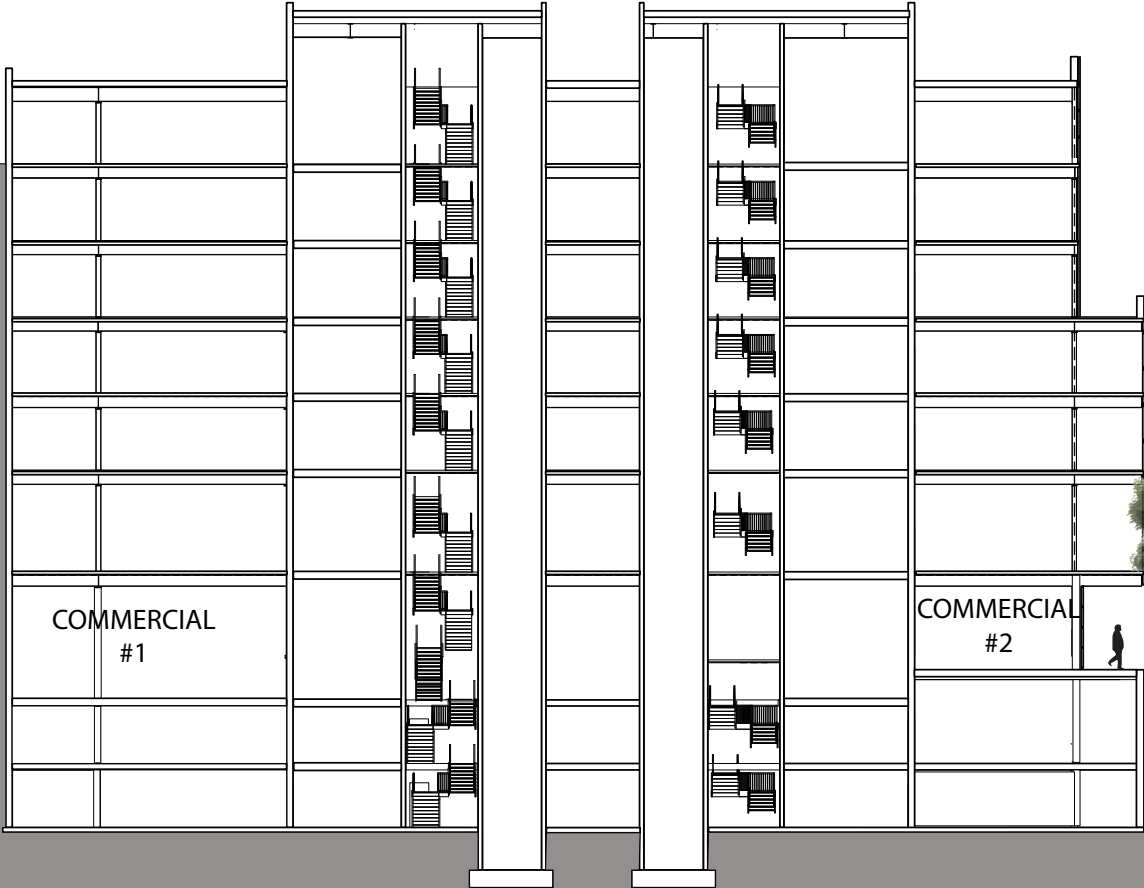

DESIGN: FLOOR PLANS + SECTIONS

Transverse Section

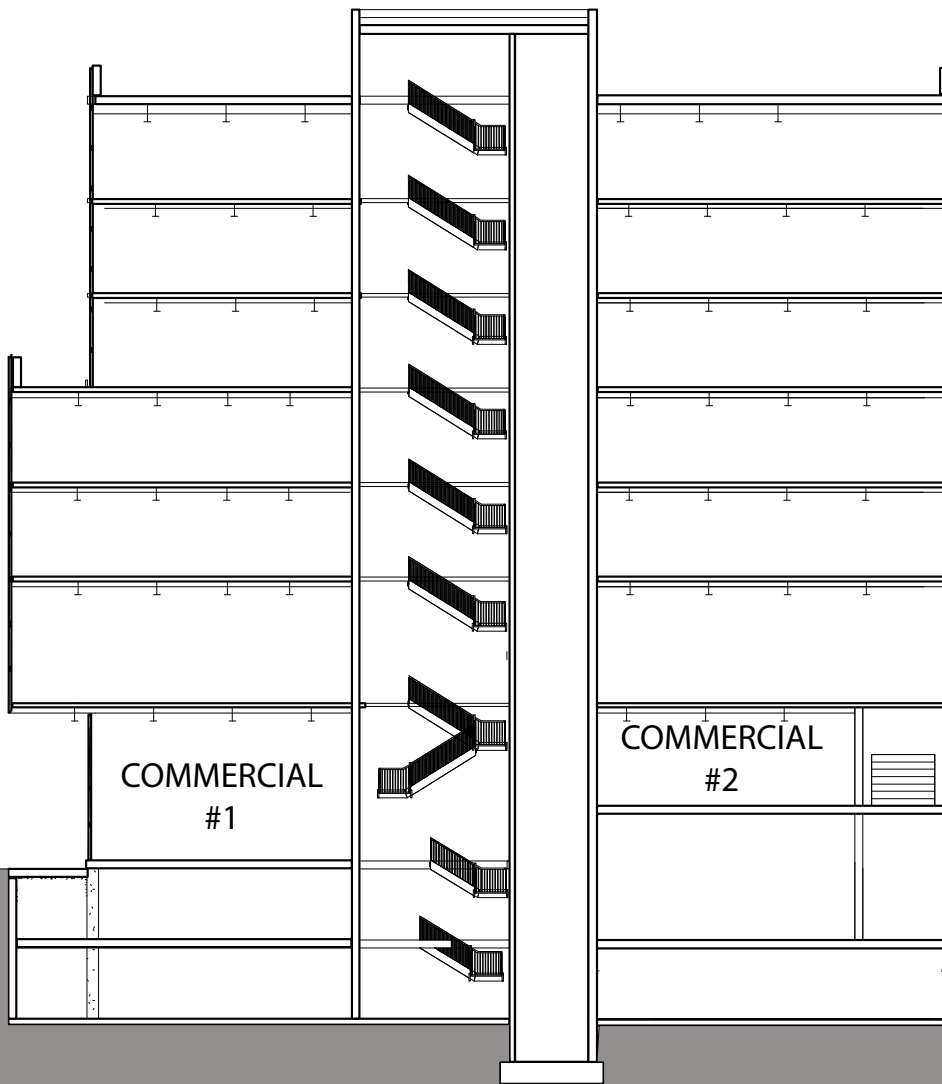

DESIGN: STRUCTURAL PLANS

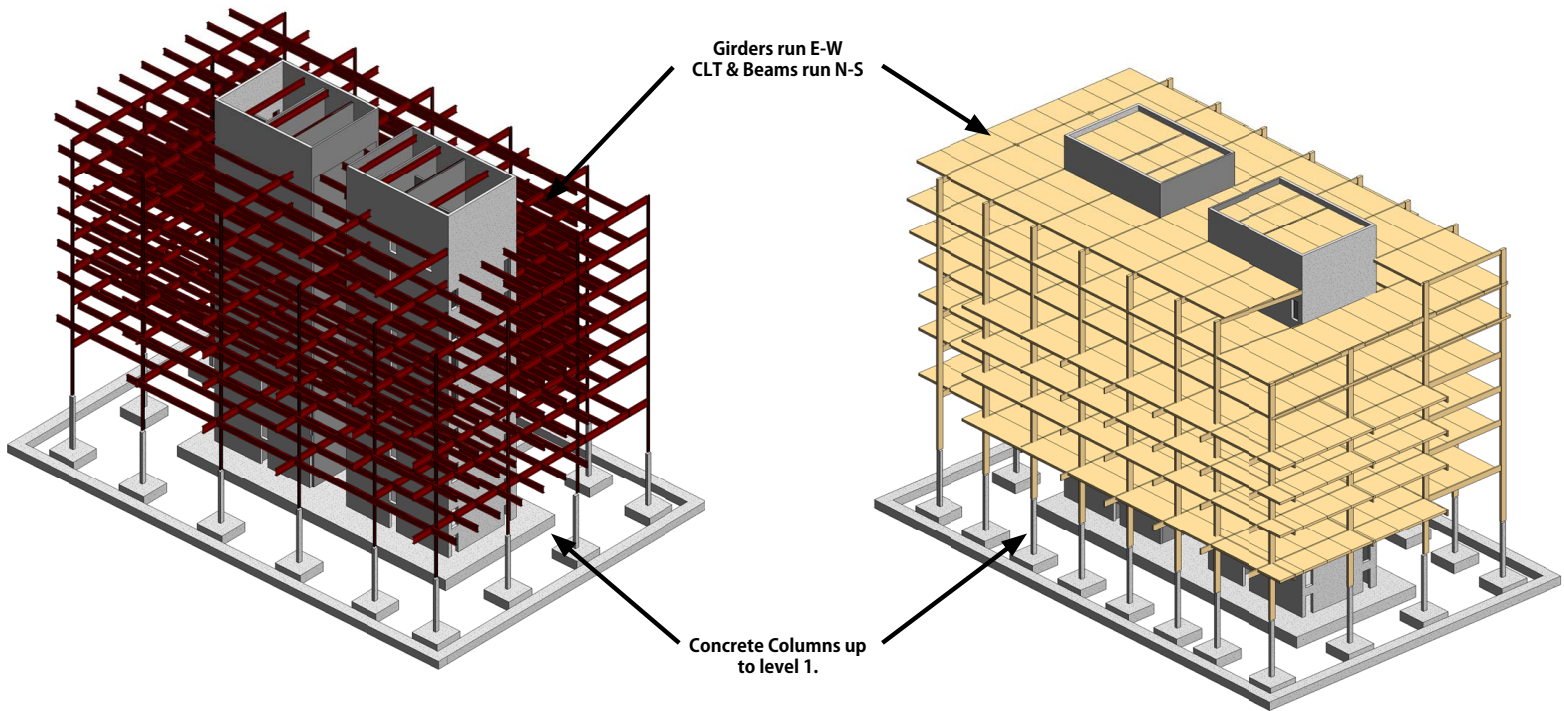

For the next portion of the design analysis, the typical steel structure has been changed out for a mass timber structure. The steel structure is comprised of a 30' x 30' grid, which includes Wide Flange girders, columns and beams. The beams are topped by a concrete slab on a steel metal deck. The shear of the building is provided by a concrete core. The wood system is a 20' x 30' grid, which includes glulam columns, glulam girders and CLT panels which function as both the beams and the decking. The wood system also includes a concrete shear core. The concrete portions of the building are all below grade at the underground parking levels. The concrete columns extend only up to level one, at which point either the steel or the wood superstructure begins.

DESIGN: STRUCTURAL PLANS

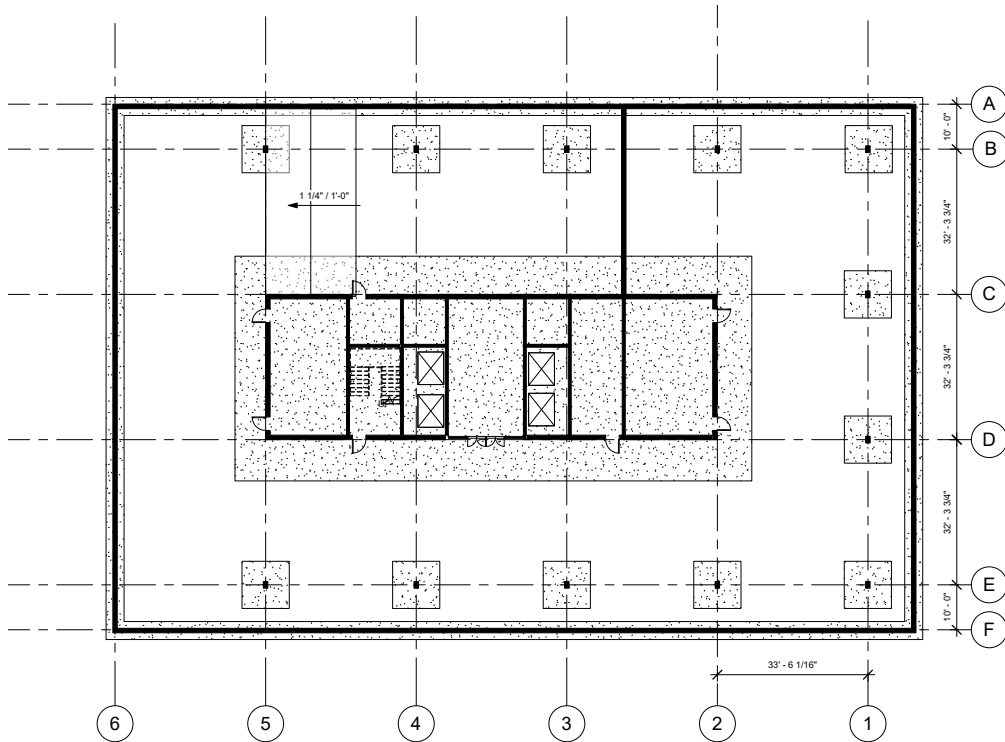

At the parking level, the adjusted grid size, which is due to the spanning limitation of the CLT, results in additional columns and additional footings. The shear core and shear core footings also enlarged slightly to reduce dead space.

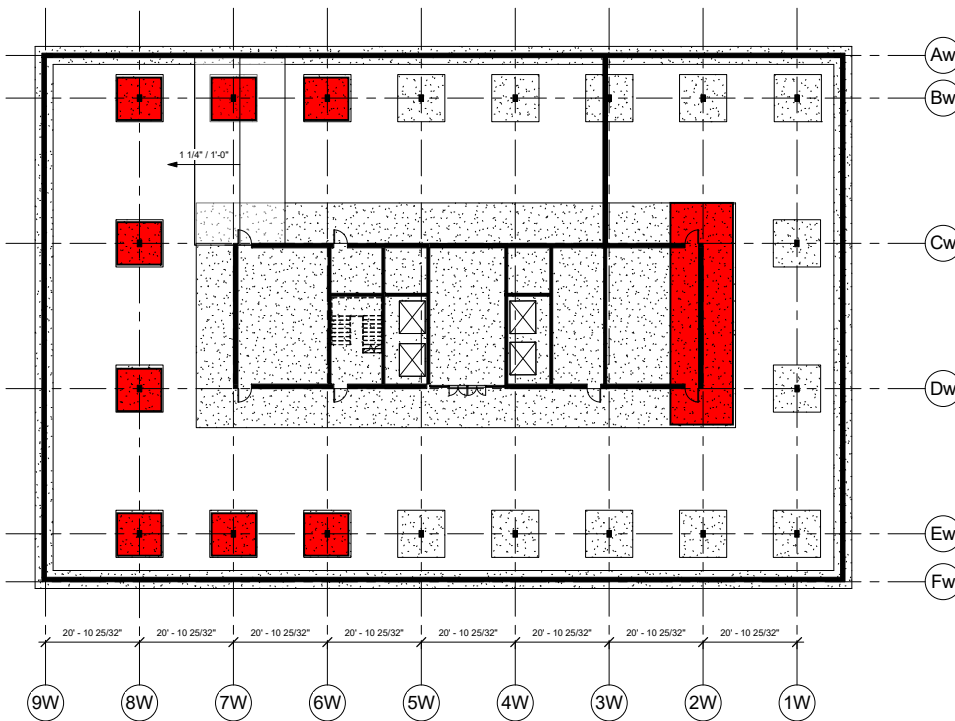

1. Core location & dims change
 - larger cenral vestibule
 - more space in restrooms
2. Columns & footings added
3. Useable space reduced



DESIGN: STRUCTURAL PLANS

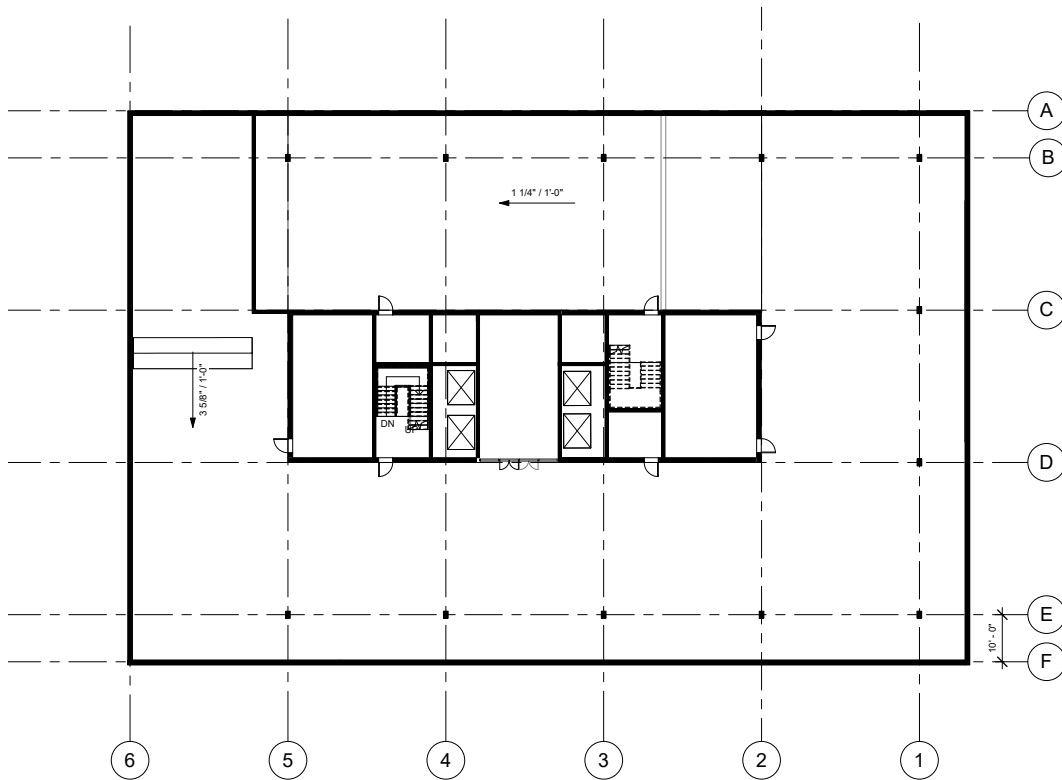

The new grid spacing results in a reduced ramp, and the additional columns reduce the number of parking spaces at the garage level. There may be ways to provide some transfer beams at the garage level to reduce the impact of the additional columns on the parking spaces. Transfer beams would have the effect of reducing the floor to ceiling height, which would require greater floor to floor heights at the parking garage levels. For the purposes of this study, transfer beams were not considered in the analysis. The wood option requires 20 columns, while the steel version only needed 12.



1. Ramp location change

DESIGN: STRUCTURAL PLANS

The addition of columns continues to interrupt the interior spaces above as well, potentially reducing useable commercial space.



1. Added Interior columns

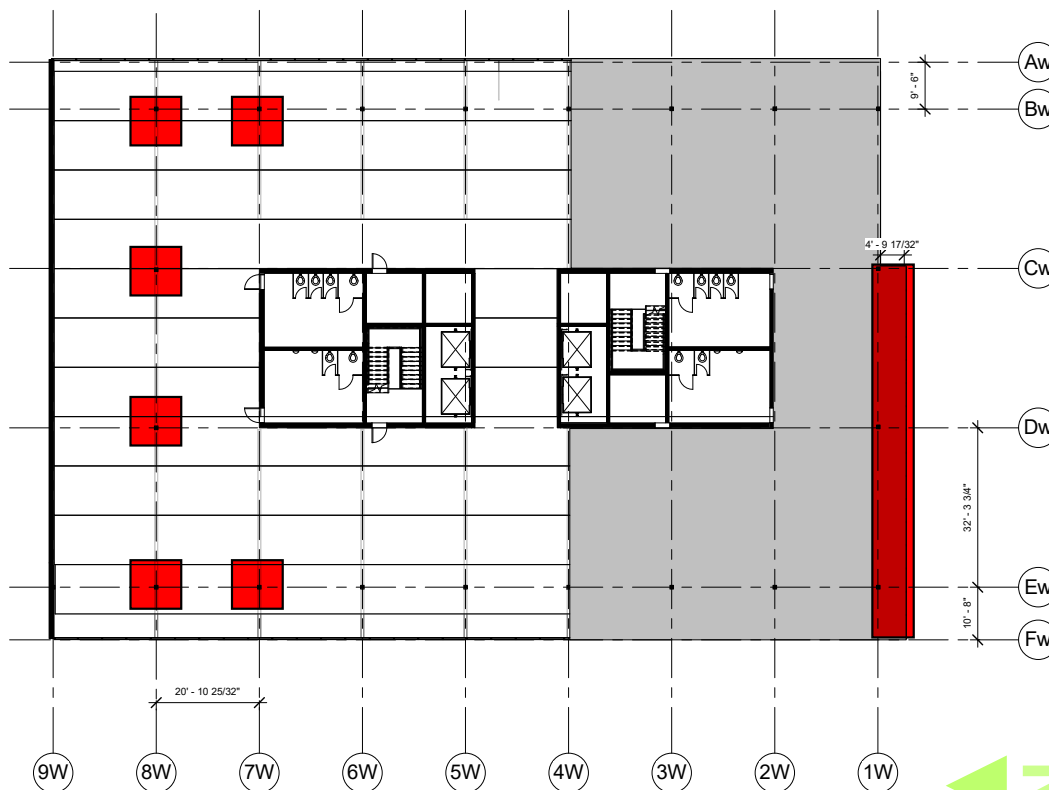

DESIGN: STRUCTURAL PLANS



Because the CLT has limited overhang capabilities, the South overhang is reduced to approximately 6 feet instead of the 10 foot overhang capability of the steel girders.

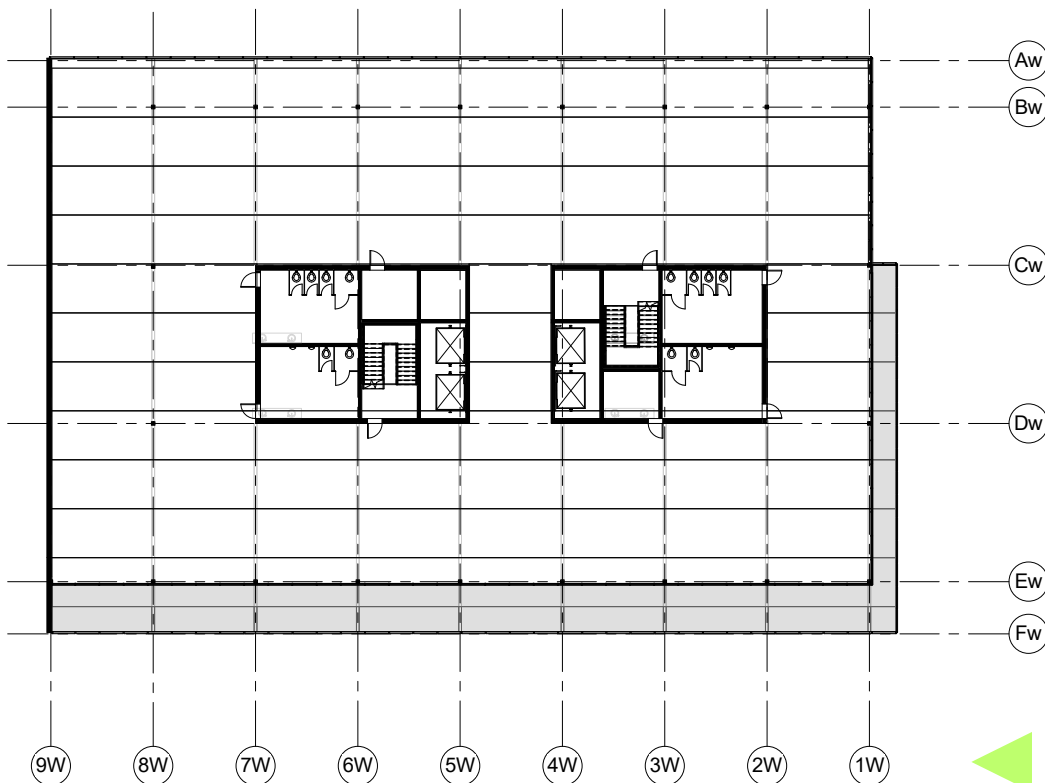

- 1. Columns added
- 2. Overhang decreased



DESIGN: STRUCTURAL PLANS



DESIGN: STRUCTURAL PLANS

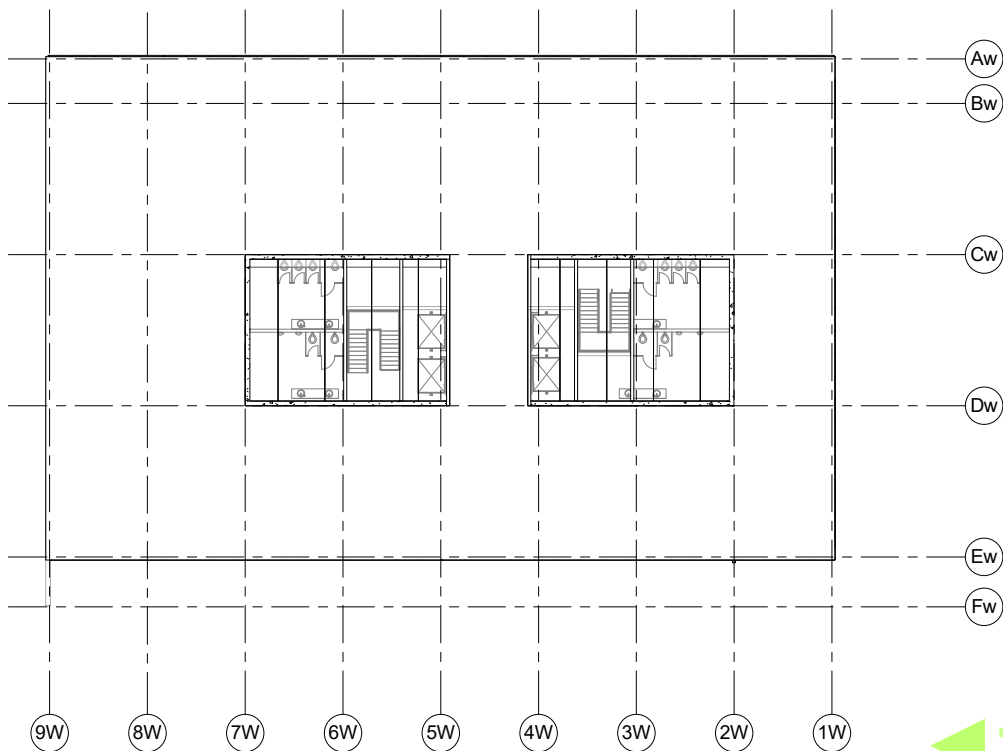
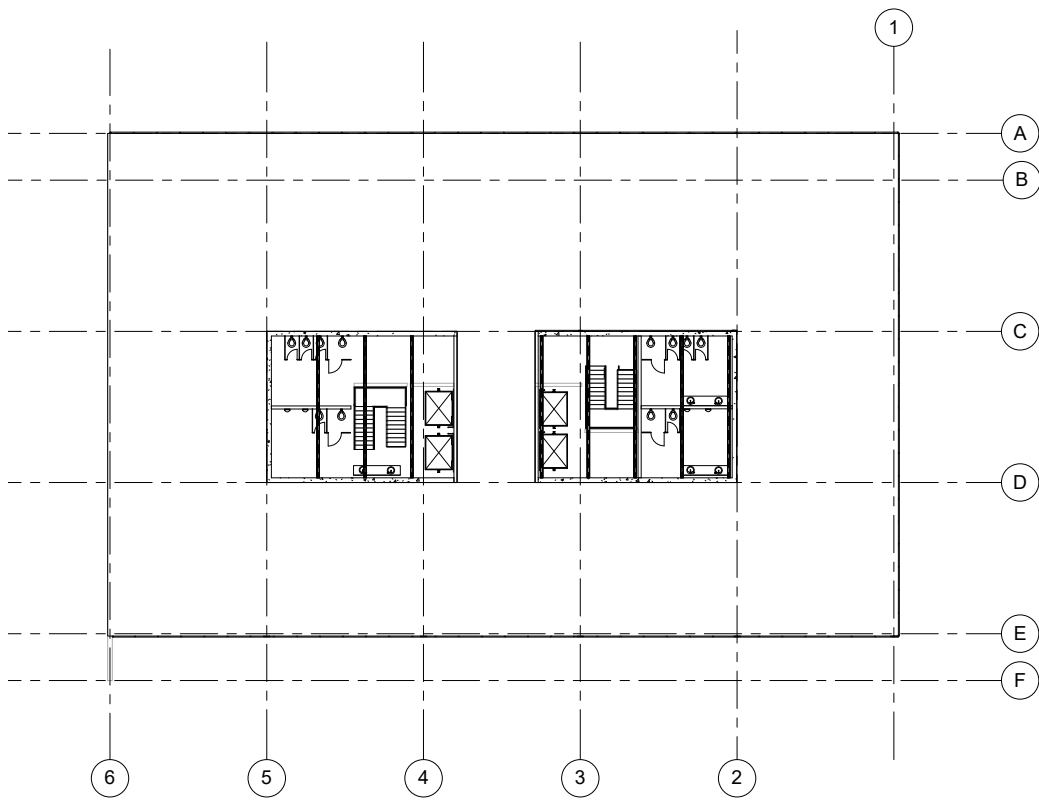

DESIGN: EXPERIENCE

View of Entry Corner



This view shows the building at dusk heading north on Fairview. You can see the vertical fins that divide the upper portion of the office space, the open and clear middle portion of the building and the forest at the ground floor plan. The dusk view shows the building as it would appear to most building, either as they arrive for work in the early morning or as they leave in the evenings. This view depicts an exposed CLT structure as it would appear from the exterior.

DESIGN: EXPERIENCE

Entry Corner Close-up



This view shows a close up of the building entry lobby. To the right you can see the cafe/bar tenant commercial space with an outdoor deck and the stream snaking down and into the building lobby.

DESIGN: EXPERIENCE

The Stream



This view shows the path between the two portions of the water filtration system. You can also see some of the stones or benches which can be used by people to rest in a sheltered environment throughout the day

DESIGN: EXPERIENCE

Interior - Wood



This view shows the interior of the space as it would appear if the wood was exposed with a raised floor system below, which will be considered the baseline point of comparison for the wood.

DESIGN: EXPERIENCE

Interior - Steel



This view shows the interior of the space as it would appear if the wood had to be covered or if the building used steel as the structural system.

CHAPTER FIVE

Costs



Cost Guidelines/Assumptions:

- Costs do not include a full building cost analysis. Rather, they are assembly costs analyses that only include specific assembly elements.

- Rather than using a guide, subcontractors were solicited to provide budgeting numbers for the costs below in current U.S. Dollars, which include material as well as installation pricing.

- Where more than 1 quote was received, the quotes were averaged and the average of all the numbers were used for pricing purposes.

- All assembly pricing includes typical general contractor mark-ups, which provide for more realistic costs that can be used as design guides.

- All quantities used for this process were exported out of a Revit model for both the Steel and wood option.

COST: COST PER ASSEMBLY

Steel

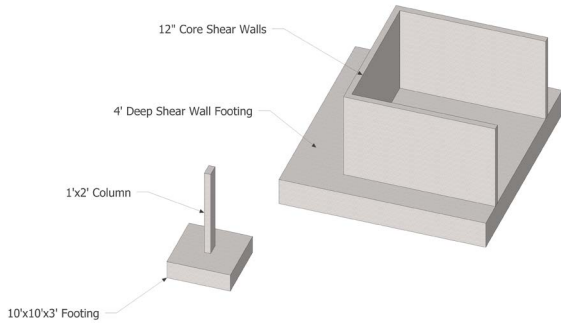

\$27.85/SF
Job

Wood

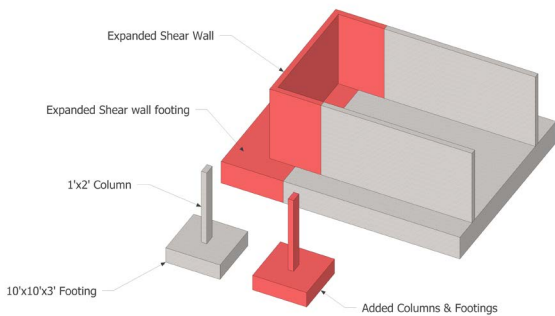

\$28.56/SF
Job

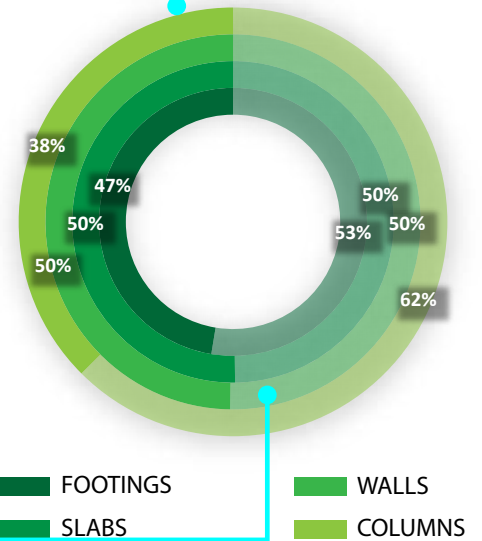

Looking at the \$/SF over the total gross square footage of the building, the foundations for the wood option include a premium because the 20' grid in one direction creates more columns and slightly enlarges the shear core and shear core footing. This in turn creates more formwork and more concrete. As can be seen in the chart above, the columns, footings and walls are what drive the price of the wood option at the foundations level.

COST: COST PER ASSEMBLY

Wood

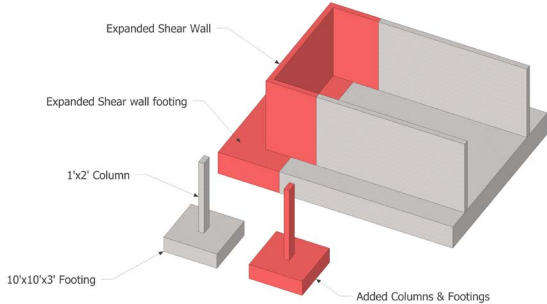

\$28.56/SF
Job

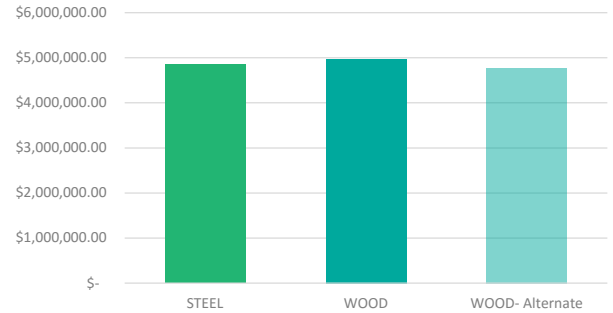

Wood - 10% Foundation Reduction

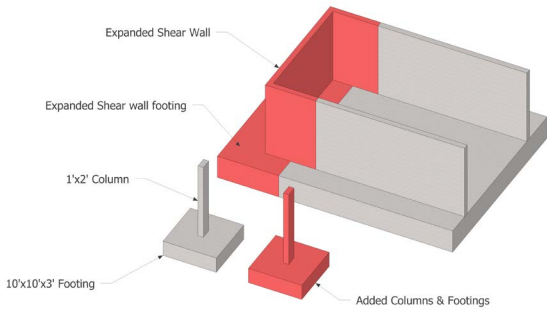

\$27.43/SF
Job

COST SAVING OPTION

However, because wood is lighter than steel, it is possible that the foundation could be reduced for the wood option. In order to calculate the quantity of the reduction required, the weights of the steel superstructure, wood superstructure and concrete decks and walls were added for both options. The outcome was that the weight of the wood option was 10% lighter than the steel option. The 10% weight reduction factor was applied to the concrete quantities of all the lateral elements in the building - this specifically includes columns, column footings, shear core and shear core footings. The result of the quantity differential yielded the lowest cost/GSF for the wood option.

The limitation of this analysis is that it is simplified and does not include engineering for other lateral forces, such as seismic and wind loads. To get a better understanding of how the weight of the superstructure may impact the concrete, the foundations would have to be engineered for the lighter system specifically. As this was not done for this part of the analysis, the results are approximations only.

COST: COST PER ASSEMBLY

Steel

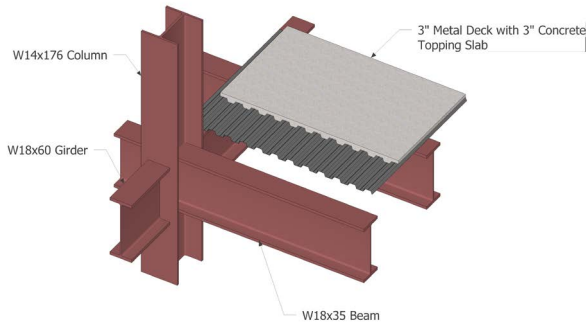

\$37.33/SF
Assembly

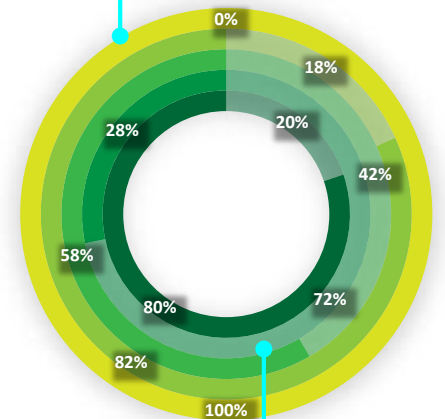

Wood

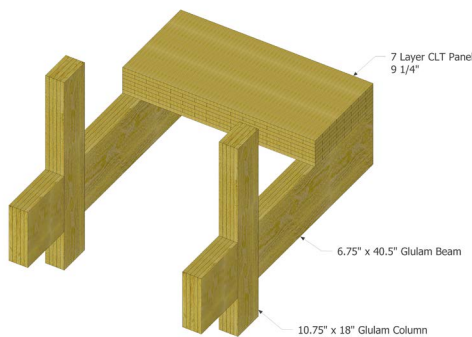

\$30.81/SF
Assembly



The cost of wood for the superstructure per SF of assembly (Floors 2-Roof) are significantly lower than the price for a steel superstructure. This is primarily due to the fact that the steel itself is more expensive than wood members for the same span, but it is also due to the fact that the steel option includes a larger number of elements for the assembly. Included in the steel price are columns, girders, metal deck, concrete at the metal deck, connections and fireproofing. Included for the wood option are glulam columns, glulam girders, CLT panels, and steel connections at the wood. As I was only able to get supply pricing for the wood members, conversations with superintendents credited below allowed me to determine labor hours per piece and determine a cost for labor on the wood option which was included in the total price for the assembly system.

COST: COST PER ASSEMBLY

Wood

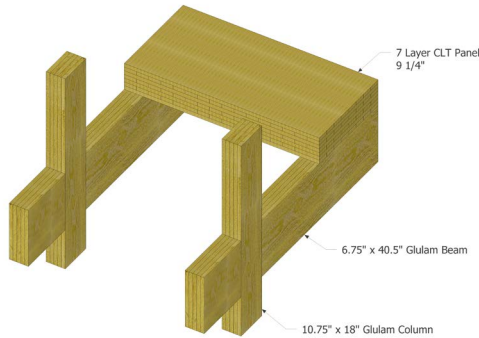

\$30.81/SF
Assembly

COST SAVING OPTION

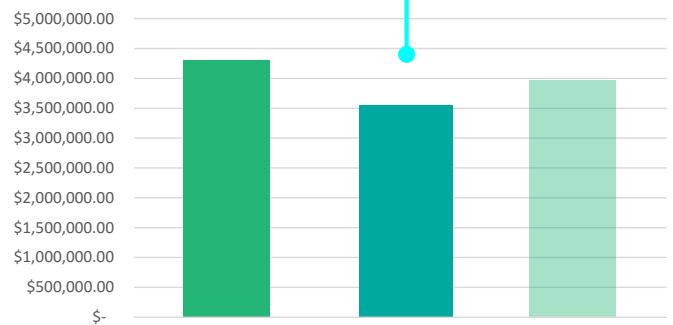

Wood -2" Topping Slab

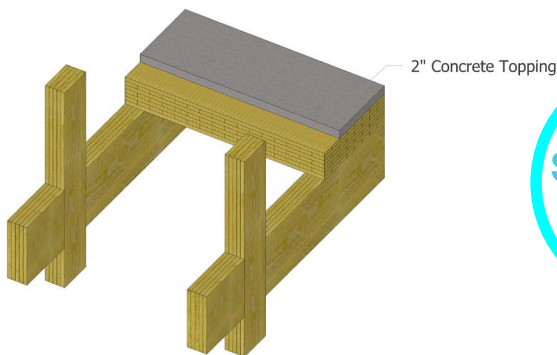

\$34.41/SF
Assembly

Because it is unclear currently whether a concrete topping slab will be required to build taller structures with CLT panels, this option was analyzed. For this analysis, a 2" topping slab was assumed, as provided in the product data for CLT panels. However, even with a topping slab, the mass timber structure represents a savings over a similar steel structure.

COST: COST PER ASSEMBLY

Steel

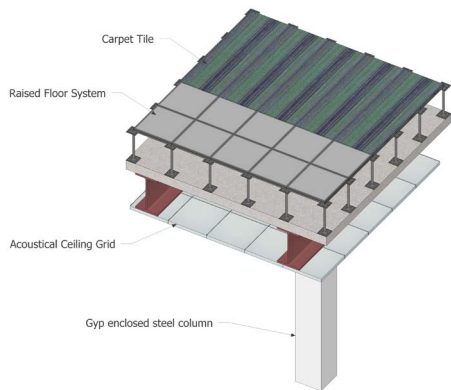

\$19.90/SF
Assembly

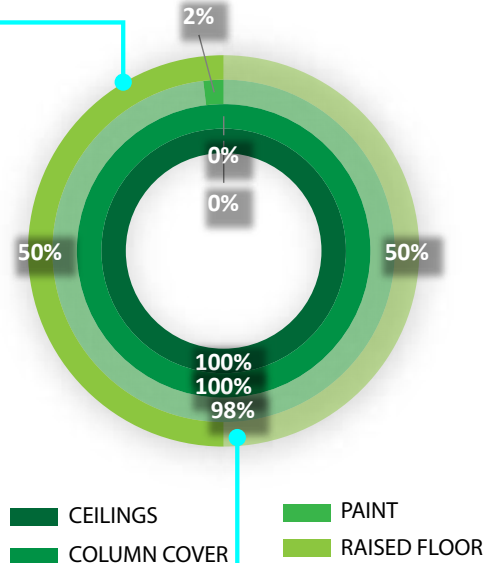

Wood

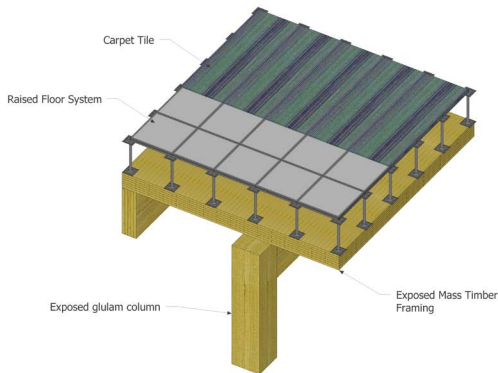

\$18.32/SF
Assembly



The analysis of the cost of finishes does not include any structural members. Because the GSA was used as the tenant for the occupied space, GSA standards for office buildings were used to determine the finishes. The documents published by the GSA (see Chapter 2) indicate that a raised flooring system is typical for their office buildings. Therefore, a finishes assembly which includes a raised flooring system is used as the baseline comparison of both options. For wood, a raised flooring system and an exposed wood structure with a clear coating makes up the majority of the finishes cost. The steel structure, however, needs to be fireproofed so a raised floor system would not remove the requirement for a dropped ceiling grid (2'x2' grid per GSA) and covered & painted columns. Again, here the steel option includes a larger number of assembly pieces, which results in a higher finishes price per SF of assembly.

COST: COST PER ASSEMBLY

Steel - Optimized

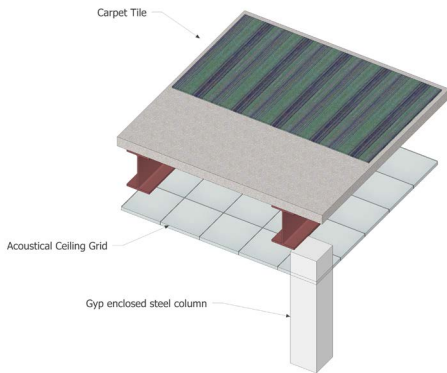

\$10.93/SF
Assembly

COST SAVING OPTION

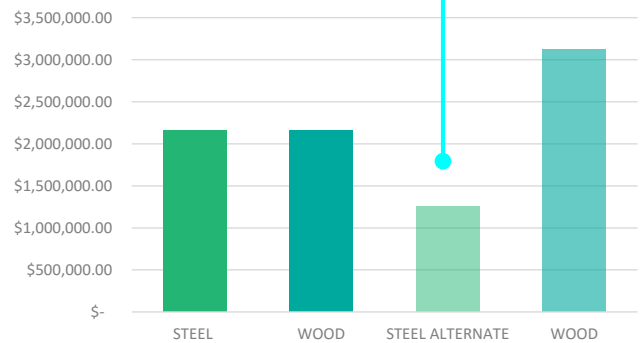

Wood - Covered

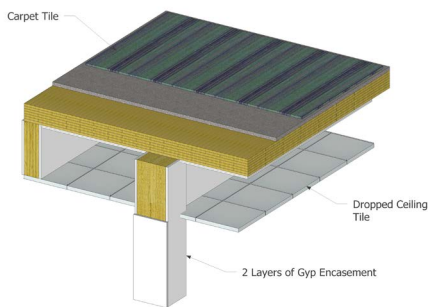

\$27.13/SF
Assembly

Because the baseline comparison for the GSA specifically would not be applicable for most other tenants, a pricing analysis alternate was done on an optimized steel version, which would only include a dropped ceiling and not a raised flooring system for all MEP needs. An alternate pricing analysis was also done on the wood option should the code dictate that all wood structure be covered with 2 layers of drywall. In the case of a covered wood system, a dropped ceiling grid would be used in lieu of a raised flooring system, as this provides for the most cost effective assembly. Nevertheless, the optimized or typical steel finishes package is the most cost efficient strategy, while the covered wood requires a substantial premium.

COST: COST PER ASSEMBLY

Steel

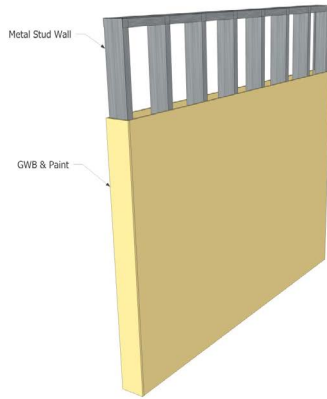

\$7.45/SF
Wall

Wood



\$13.04/SF
Wall

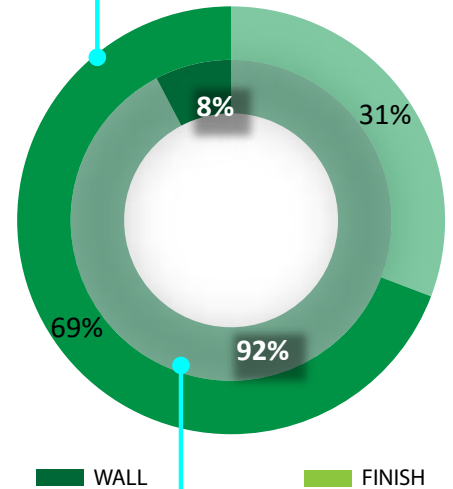

When comparing the price of non-structural interior partitions, the industry standard light gauge steel, non-insulated, light gauge steel wall with a layer of painted gypsum board on either side is about half the cost per square foot as a CLT wall. The CLT wall pricing in this instance also include a clear coat and finish on the wood.

COST: COST PER ASSEMBLY

Summary - Baseline Comparison

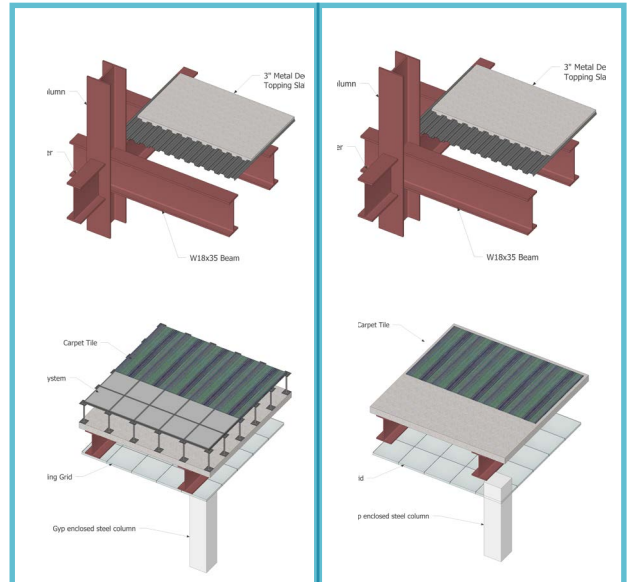
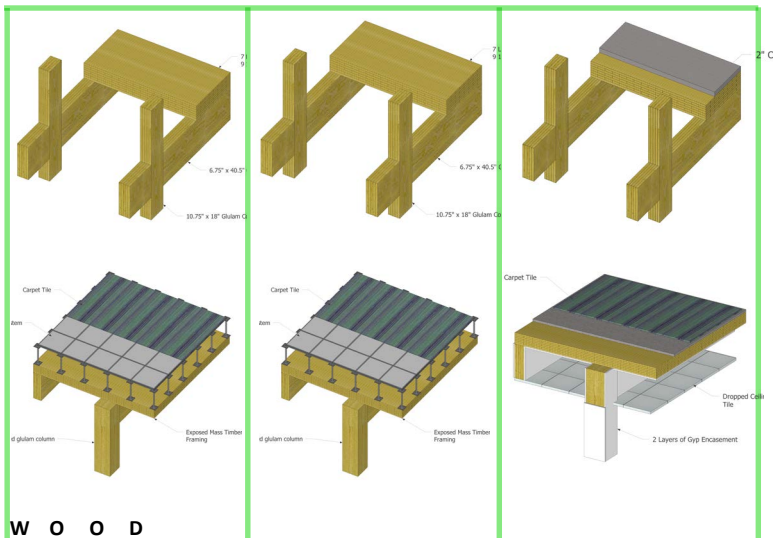

Wood - Baseline	Wood - Reduced Foundations	Wood - Covered	
Exposed wood Standard Foundations	Exposed Wood Reduced Foundations	Covered Wood Concrete Topping Typical Foundations	
\$ 225,534	\$ 28,735	\$ 1,655,064	Optimized Steel Dropped ceiling No Raised flooring
\$ (807,757)	\$ (1,004,556)	\$ 621,773	Baseline Steel Dropped Ceiling Raised flooring

The diagram above shows the price differential for the wood options which is produced when comparing a combination of foundations, superstructure and finishes alternates mentioned earlier in the chapter. The green numbers show instances where wood is cheaper than steel while the red numbers indicate where the wood is more expensive than the steel option. For the GSA, which may require a raised flooring system, the wood option, if the wood can be allowed to be exposed by the code, represents a cost savings over the steel option. This savings is exaggerated when the concrete foundations can be reduced. The primary driving factor for this cost savings is that a raised flooring system adds a significant amount of cost and additional finishes components to the steel, which already has a larger price for the superstructure.

However, for developers other than the GSA, who typically do not choose to use a raised flooring system, the steel total package is cheaper than the wood option. If the wood is covered, then it represents a premium of \$1,655,064. In the best case scenario for wood (exposed with reduced foundations), the premium is only \$28,735 when compared to the optimized steel. Over the entire cost of the building, this is not a significant premium and may well be worth looking into further by interested developers.

However, because these total numbers only represent the sum of specific assembly components and do not represent a full building cost analysis, there are many hidden costs that were assumed equal for the purposes of this project but that may have a substantial impact on price. Of particular interest for future study would be an analysis of MEP (Mechanical, Electrical & Plumbing) systems and costs. With more time, the design could be developed further, which would lead to more accurate results.

COST: COST PER ASSEMBLY

Summary

GSA STANDARDS - EXPOSED WOOD

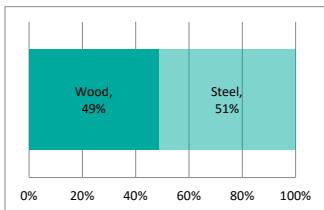
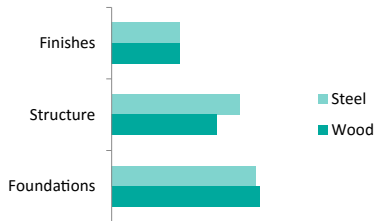

GSA STANDARDS - FOUNDATION REDUCTION

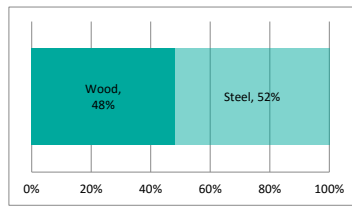
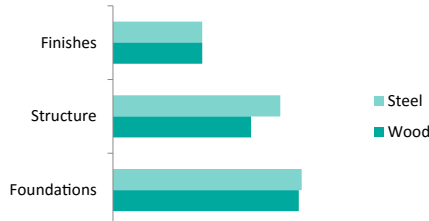

GSA STANDARD - COVERED WOOD

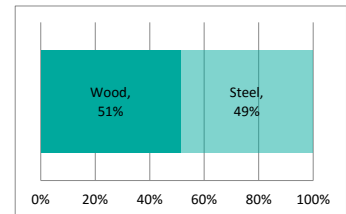
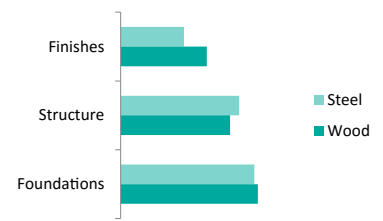

OPTIMIZED STEEL- EXPOSED WOOD

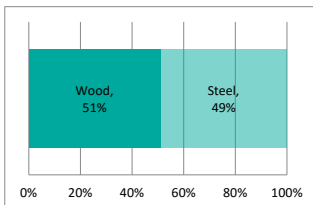
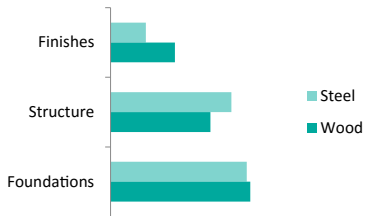

OPTIMIZED STEEL - FOUNDATION REDUCTION

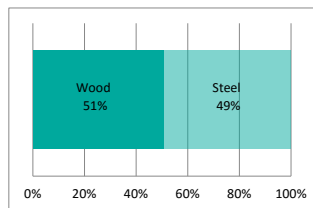
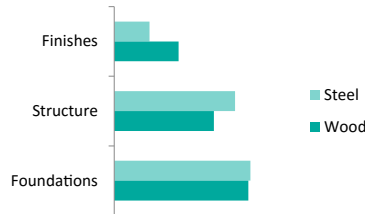

OPTIMIZED STEEL - COVERED WOOD

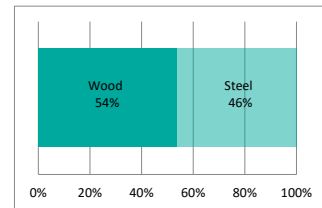
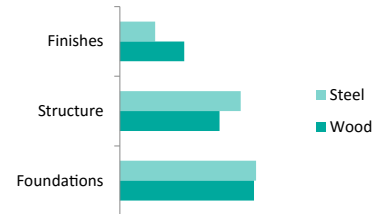

The diagrams above show the price differences broken out for each comparison category by foundations, superstructure and finishes.

COST: COSTING SHEETS

Foundations

DESCRIPTION	DIMENSIONS	COUNT	SF	CF	CV	Reduction	\$/Unit	Total Material \$	UMH	Total UMH	Labor \$	\$ Equip/Unit	Equip \$	Total \$	REF:
Spread Footings at Columns	10' x 10' x 42"	12	4630	171.4815			\$ 675.00	\$ 115,790.00	inc	inc	inc	inc	inc	\$ 115,790.00	1 Sub Quote
Continuous Wall Footing	48" x 36"		7063.4	261.6074			\$ 675.00	\$ 176,585.00	inc	inc	inc	inc	inc	\$ 176,585.00	1 Sub Quote
Shear Wall Footing	4' Deep		23800	851.8519			\$ 715.00	\$ 699,074.07	inc	inc	inc	inc	inc	\$ 699,074.07	1 Sub Quote
Concrete Pad	Sub bid	1					\$ 45,000.00	\$ 45,000.00	inc	inc	inc	inc	inc	\$ 45,000.00	1 Sub Quote
4" SOG			20063	6680.979	247.4437		\$ 675.00	\$ 167,024.48	inc	inc	inc	inc	inc	\$ 167,024.48	1 Sub Quote
12" PT Deck			38823				\$ 50.00	\$ 1,941,150.00	inc	inc	inc	inc	inc	\$ 1,941,150.00	1 Sub Quote
Concrete Wall	12"			22456.35	831.7167		\$ 675.00	\$ 564,408.25	inc	inc	inc	inc	inc	\$ 564,408.25	1 Sub Quote
12" Shear core wall	12" Wide			27464.14	1017.19		\$ 675.00	\$ 686,603.50	inc	inc	inc	inc	inc	\$ 686,603.50	1 Sub Quote
Concrete Columns	12" x 18"	12		352.5	13,055.56		\$ 675.00	\$ 8,812.50	inc	inc	inc	inc	inc	\$ 8,812.50	1 Sub Quote
10% Waste							\$ 675.00	\$ 229,118.42	inc	inc	inc	inc	inc	\$ 229,118.42	1 Sub Quote
Includes: Rebar, formwork, labor & equipment															
174041 5371.671															
Business Tax 888% Additional Insurance 31,148.01 Wrap Insurance Policy 2,270.26 Bidder's Risk Insurance @ 0.00% Escalation @ 0.00% Contractor's Contingency @ 1.50% Overhead & Profit @ 4.00% Escalation @ 0.00% TOTAL 4,846,376.60 27.85 \$/SF Job															

DESCRIPTION	DIMENSIONS	COUNT	SF	CF	CV	Reduction	\$/Unit	Total Material \$	UMH	Total UMH	Labor \$	\$ Equip/Unit	Equip \$	Total \$	REF:
Spread Footings at Columns	10' x 10' x 42"	20	7717.5	285.8338		none	\$ 675.00	\$ 192,937.50	inc	inc	inc	inc	inc	\$ 192,937.50	1 Sub Quote
Continuous Wall Footing	48" x 36"		7063.4	261.6074		none	\$ 675.00	\$ 176,585.00	inc	inc	inc	inc	inc	\$ 176,585.00	1 Sub Quote
Shear Wall Footing	4' Deep		24000	888.8889		none	\$ 715.00	\$ 683,555.56	inc	inc	inc	inc	inc	\$ 683,555.56	1 Sub Quote
%Weight Reduction Factor						0%									
Concrete Pad	Sub bid	1					\$ 45,000.00	\$ 45,000.00	inc	inc	inc	inc	inc	\$ 45,000.00	1 Sub Quote
4" SOG			20063	6680.979	247.4437		\$ 675.00	\$ 167,024.48	inc	inc	inc	inc	inc	\$ 167,024.48	1 Sub Quote
12" PT Deck							\$ 50.00	\$ 1,924,000.00	inc	inc	inc	inc	inc	\$ 1,924,000.00	1 Sub Quote
Concrete Wall	12"			21941.45	812.6463		\$ 675.00	\$ 548,536.25	inc	inc	inc	inc	inc	\$ 548,536.25	1 Sub Quote
12" Shear core wall	12" Wide			28474	1054.539	none	\$ 675.00	\$ 711,850.00	inc	inc	inc	inc	inc	\$ 711,850.00	1 Sub Quote
Concrete Columns	12" x 18"	20		587.5	21,792.6	none	\$ 675.00	\$ 14,887.50	inc	inc	inc	inc	inc	\$ 14,887.50	1 Sub Quote
10% Waste							\$ 675.00	\$ 241,162.07	inc	inc	inc	inc	inc	\$ 241,162.07	1 Sub Quote
Includes: Rebar, formwork, labor & equipment															
0.6079797873 5555.234															
Business Tax 888% Additional Insurance 31,949.24 Wrap Insurance Policy 2,328.97 Bidder's Risk Insurance @ 0.00% Escalation @ 0.00% Contractor's Contingency @ 1.50% Overhead & Profit @ 4.00% Escalation @ 0.00% TOTAL 4,971,066.66 28.56 \$/SF Job															

COST: COSTING SHEETS

Foundations - Wood Alternate

FOUNDATION - ALTERNATE	Dimensions	COUNT	SF	CF	CV	Reduction	\$/Unit	Total Material \$	UMH	Total UMH	Labor \$	\$ Equip / Unit	Equip \$	Total \$	REF:
Spread footing at Columns	10' x 10' x 4.2"	20	7777.5	285.4338	255.3994	\$	675.00	\$ 1772,393.84	Inc	Inc	Inc	Inc	\$	1772,393.84	1 Sub Quote
Continuous Wall Footing	48" x 36"	-	7063.4	261.6074	234.752	\$	675.00	\$ 1517,782.62	Inc	Inc	Inc	Inc	\$	1517,782.62	1 Sub Quote
Shear Wall Footing	4' Deep	-	24000	888.8889	794.242	\$	715.00	\$ 567,883.01	Inc	Inc	Inc	Inc	\$	567,883.01	1 Sub Quote
% Weight Reduction Factor		0%							Inc	Inc	Inc	Inc			
Came Pad	Sub/bld	1					\$ 45,000.00	\$ 45,000.00	Inc	Inc	Inc	Inc	\$	45,000.00	1 Sub Quote
4' SOG			20063	6680379	247,4437		\$ 675.00	\$ 167,024.48	Inc	Inc	Inc	Inc	\$	167,024.48	1 Sub Quote
12' FT Deck			38489				\$ 50.00	\$ 1,924,000.00	Inc	Inc	Inc	Inc	\$	1,924,000.00	1 Sub Quote
Concrete Wall	12"		21941.45	812.6463			\$ 675.00	\$ 548,536.25	Inc	Inc	Inc	Inc	\$	548,536.25	1 Sub Quote
12' Shear core wall	12' Wide		28274	1054.593	942.3019	\$	675.00	\$ 638,053.79	Inc	Inc	Inc	Inc	\$	638,053.79	1 Sub Quote
Concrete Columns	12' x 18"	20	597.5	21.76926	19.44238	\$	675.00	\$ 131,123.61	Inc	Inc	Inc	Inc	\$	131,123.61	1 Sub Quote
10% Waste		10%			357.2772	\$	675.00	\$ 241,162.07	Inc	Inc	Inc	Inc	\$	241,162.07	1 Sub Quote
Includes: Rebar, Formwork, Labor & equipment		0				5287.689			Inc	Inc	Inc	Inc	\$	4,472,599.77	SUB TOTAL
Reduction Factor =									Inc	Inc	Inc	Inc	\$	30,684.50	
									Inc	Inc	Inc	Inc	\$	2,236.48	
									Inc	Inc	Inc	Inc	\$	-	
									Inc	Inc	Inc	Inc	\$	-	
									Inc	Inc	Inc	Inc	\$	67,094.40	
									Inc	Inc	Inc	Inc	\$	201,283.19	
									Inc	Inc	Inc	Inc	\$	-	
									Inc	Inc	Inc	Inc	\$	4,774,258.34	TOTAL
									Inc	Inc	Inc	Inc	\$	2743	\$97706

- Business Tax .096%
- Additional Insurance
- Wrap Insurance Policy
- Builder's Risk Insurance @ 0.00%
- Design Contingency @ 0.00%
- Estimating Contingency @ 0.00%
- Contractor's Contingency @ 1.50%
- Overhead & Profit @ 4.00%
- Escalation @ 0.00%

COST: COSTING SHEETS

Superstructure

DESCRIPTION	Dimensions	Area	Volume	LF	Weight/ LF	Total Weight	Tons	\$/Unit	Total Mat \$	UMH	Total UMH	Labor \$	Total Labor \$	Total \$	REF.
Steel Columns	W/14x176			1104	176	194304	97.452	\$4,282.00	\$18,335,524.00	inc	inc	inc	inc	\$416,004.86	Averaged, 3 quotes
Steel Beams	W/18x35			13868	35	483380	242.62	\$4,282.00	\$18,335,524.00	inc	inc	inc	inc	\$1,039,198.58	Averaged, 3 quotes
Steel Girders	W/18x60			2932	60	175980	97.69	\$4,282.00	\$18,335,524.00	inc	inc	inc	inc	\$375,488.52	Averaged, 3 quotes
Connections	15%							\$4,282.00	\$274,603.80	inc	inc	inc	inc	\$724,603.80	Averaged, 3 quotes
Spray on fire proofing		115155						\$9.38	\$1,080,001.90	inc	inc	inc	inc	\$1,080,001.90	1 Sub Quote
Metal Deck	3" on 3"	115155			2.5	287897.5		\$3.09	\$355,828.95	inc	inc	inc	inc	\$355,828.95	Averaged, 3 quotes
Concrete topping	3" on 3"	115155			150	4318312.5		\$4.22	\$585,954.10	inc	inc	inc	inc	\$585,954.10	1 Sub Quote
Tower Crane Excluded - will be analyzed separately with schedule															
Includes supply & install - prevailing wage if not provided by sub															
2794,7618 635,60555 6437,920589 SUB TOTAL 4,027,080.77															

Business Tax .686%
 Additional Insurance
 Wrap Insurance Policy
 0 OWNER
 Builder's Risk Insurance @ 0.00%
 0 OWNER
 Design Contingency @ 0.00%
 0 OWNER
 Estimating Contingency @ 0.00%
 0
 Contractor's Contingency @ 1.50%
 181,218.63
 Overhead & Profit @ 4.00%
 4,298,344.93
 Escalation @ 0.00%
 0
4,298,344.93
 TOTAL
37.33 \$/SF ASSEMBLY

DESCRIPTION	Dimensions	Count	Length	LF	Weight/ LF	Total Weight	Tons	Mat \$/Unit	Total Mat \$	UMH	Total UMH	Labor \$	Total Labor \$	Total \$	REF.
Glulam Columns	10.75" x 18" x 28	60	28	1680	47	78960	39.48	\$1,201.10	\$72,066.60	2.5	150	\$50.00	\$7,500.00	\$79,566.60	Averaged, 3 quotes, RS Means
100% Waste		6						\$1,201.10	\$7,206.60	2.5	15	\$50.00	\$750.00	\$7,956.60	Averaged, 3 quotes, RS Means
100% Waste	10.75" x 18" x 14	20	14	280	47	13160	6.58	\$687.21	\$13,754.40	1.5	30	\$50.00	\$1,500.00	\$15,254.40	Averaged, 3 quotes, RS Means
100% Waste		2						\$687.21	\$1,375.44	1.5	3	\$50.00	\$150.00	\$1,525.44	Averaged, 3 quotes, RS Means
Glulam Girders	6.75" x 40.5"	155	30	4650	66.5	309225	154.6125	\$1,648.40	\$355,502.00	1.5	232.5	\$50.00	\$11,625.00	\$367,127.00	Averaged, 3 quotes, RS Means
100% Waste		155						\$1,648.40	\$253,560.00	1.5	232.5	\$50.00	\$11,625.00	\$265,185.00	Averaged, 3 quotes, RS Means
7 Layer CLT	9.25" x 10'-0"	576			23	287897.5	1439.4375	\$22.55	\$25,967,45.25	1.5	864	\$50.00	\$43,200.00	\$2,629,945.25	1 Supplier quote
100% Waste		576						\$21.00	\$9,000.00	1.5	86.4	\$50.00	\$4,320.00	\$4,320.00	1 Supplier quote
Connections	65,000lbs/truck	12						\$600.00	\$7,200.00	inc	inc	inc	inc	\$7,200.00	Averaged, 3 quotes
Transportation	15%							\$4,282.00	\$74,603.80	inc	inc	inc	inc	\$74,603.80	
Tower Crane Excluded - will be analyzed separately with schedule															
Includes supply & install - prevailing wage if not provided by sub															
1704,2398 \$3,254,003.69 SUB TOTAL 3,324,211.19															

Business Tax .686%
 Additional Insurance
 Wrap Insurance Policy
 0 OWNER
 Builder's Risk Insurance @ 0.00%
 0 OWNER
 Design Contingency @ 0.00%
 0 OWNER
 Estimating Contingency @ 0.00%
 0
 Contractor's Contingency @ 1.50%
 149,589.50
 Overhead & Profit @ 4.00%
 4.50%
 3,548,130.06
 Escalation @ 0.00%
 0
3,548,130.06
 TOTAL
30.81 \$/SF ASSEMBLY

COST: COSTING SHEETS

Finishes - Steel

FINISHES	Description	Add'l	Area	LF	\$/Unit	Total \$	REF:
	Dropped Ceiling	ACT 2x2 Panel	115155		\$ 4.50	\$ 518,197.50	1 Sub Quote
	GWB at Columns			800	\$ 22.00	\$ 17,600.00	1 Sub Quote
	Painting		6240		\$ 1.56	\$ 9,734.40	1 Sub Quote
	Raised Flooring		115155		\$ 12.80	\$ 1,473,984.00	1 Sub Quote
			121395			\$ 2,019,515.90	SUB TOTAL
						\$ 13,853.88	0.69% Business Tax .686%
						\$ 1,009.76	0.05% Additional Insurance
						\$ -	0 OWNER Wrap Insurance Policy
						\$ -	0 OWNER Builder's Risk Insurance @ 0.00%
						\$ -	0 OWNER Design Contingency @ 0.00%
						\$ -	0 OWNER Estimating Contingency @ 0.00%
						\$ 30,292.74	1.50% Contractor's Contingency @ 1.50%
						\$ 90,878.22	4.50% Overhead & Profit @ 4.00%
						\$ -	0 Escalation @ 0.00%
						\$ 2,155,550.49	TOTAL
						\$ 2,291,585.08	TOTAL
						\$ 19,900	\$/SF ASSEMBLY

Business Tax .686%
 Additional Insurance
 Wrap Insurance Policy
 Builder's Risk Insurance @ 0.00%
 Design Contingency @ 0.00%
 Estimating Contingency @ 0.00%
 Contractor's Contingency @ 1.50%
 Overhead & Profit @ 4.00%
 Escalation @ 0.00%

FINISHES - STEEL ALTERNATE	Description	Add'l	Area	LF	\$/Unit	Total \$	REF:
	Dropped Ceiling	ACT 2x2 Panel	115155		\$ 4.50	\$ 518,197.50	1 Sub Quote
	GWB at Columns			800	\$ 22.00	\$ 17,600.00	1 Sub Quote
	Painting		6240		\$ 1.56	\$ 9,734.40	1 Sub Quote
	Typical carpet tile		115155		\$ 5.50	\$ 633,352.50	1 Sub Quote
						\$ 1,178,884.40	SUB TOTAL
						\$ 8,087.15	0.69% Business Tax .686%
						\$ 589.44	0.05% Additional Insurance
						\$ -	0 OWNER Wrap Insurance Policy
						\$ -	0 OWNER Builder's Risk Insurance @ 0.00%
						\$ -	0 OWNER Design Contingency @ 0.00%
						\$ -	0 OWNER Estimating Contingency @ 0.00%
						\$ 17,683.27	1.50% Contractor's Contingency @ 1.50%
						\$ 53,049.80	4.50% Overhead & Profit @ 4.00%
						\$ -	0 Escalation @ 0.00%
						\$ 1,258,294.05	TOTAL
						\$ 10.93	\$/SF ASSEMBLY

Business Tax .686%
 Additional Insurance
 Wrap Insurance Policy
 Builder's Risk Insurance @ 0.00%
 Design Contingency @ 0.00%
 Estimating Contingency @ 0.00%
 Contractor's Contingency @ 1.50%
 Overhead & Profit @ 4.00%
 Escalation @ 0.00%

COST: COSTING SHEETS

Finishes - Wood

FINISHES	Description	Add'l	Area	LF	\$/Unit	Total \$	REF:
	Raised Flooring		115155		\$ 12.80	1,473,984.00	1 Sub Quote
	Clear coat/Stain	CLT,beam, col	159955		\$ 3.14	502,258.70	1 Sub Quote
			60.6025			1,976,242.70	SUB TOTAL
			319910			13,557.02	0.69%
						988.12	0.05%
						-	0 OWNER
						-	0 OWNER
						-	0 OWNER
						29,643.64	1.50%
						88,930.92	4.50%
						-	0
						2,109,362.41	TOTAL
						18,3176	\$/SF ASSEMBLY

Business Tax .686%
 Additional Insurance
 Wrap Insurance Policy
 Builder's Risk Insurance @ 0.00%
 Design Contingency @ 0.00%
 Estimating Contingency @ 0.00%
 Contractor's Contingency @ 1.50%
 Overhead & Profit @ 4.00%
 Escalation @ 0.00%

FINISHES - WOOD ALTERNATE	Description	Add'l	Area	LF	\$/Unit	Total \$	REF:
	Dropped Ceiling	ACT 2x2 Panel	115155		\$ 4.50	518,197.50	1 Sub Quote
	Painting		10400		\$ 1.56	16,224.00	1 Sub Quote
	Typical carpet tile		115155		\$ 5.50	633,352.50	1 Sub Quote
	GWB Cover	CLT,beam, col	319910		\$ 5.50	1,759,505.00	1 Sub Quote
			60.6025			2,927,279.00	SUB TOTAL
						20,081.13	0.69%
						1,463.64	0.05%
						-	0 OWNER
						-	0 OWNER
						-	0 OWNER
						43,909.19	1.50%
						131,727.56	4.50%
						-	0
						3,124,460.51	TOTAL
						27.13	\$/SF ASSEMBLY

Business Tax .686%
 Additional Insurance
 Wrap Insurance Policy
 Builder's Risk Insurance @ 0.00%
 Design Contingency @ 0.00%
 Estimating Contingency @ 0.00%
 Contractor's Contingency @ 1.50%
 Overhead & Profit @ 4.00%
 Escalation @ 0.00%

COST: COSTING SHEETS

Interior Walls

FINISHES						
Description	Add'l	Area	LF	\$/Unit	Total \$	REF:
Metal Stud Wall	10' tall non-structural		800	\$ 18.00	\$ 14,400.00	1 Sub Quote
Painting			16000	\$ 1.56	\$ 24,960.00	1 Sub Quote
GWB			16000	\$ 5.50	\$ 88,000.00	1 Sub Quote
					\$ 127,360.00	SUB TOTAL
					\$ 873.69	0.69%
					\$ 63.68	0.05%
					\$ -	0 OWNER
					\$ -	0 OWNER
					\$ -	0 OWNER
					\$ -	0 OWNER
					\$ 1,910.40	1.50%
					\$ 5,731.20	4.50%
					\$ -	0
					\$ 135,938.97	TOTAL
					\$ 7.45	\$/SF ASSEMBLY

Business Tax .686%
 Additional Insurance
 Wrap Insurance Policy
 Builder's Risk Insurance @ 0.00%
 Design Contingency @ 0.00%
 Estimating Contingency @ 0.00%
 Contractor's Contingency @ 1.50%
 Overhead & Profit @ 4.00%
 Escalation @ 0.00%

FINISHES						
Description	Add'l	Area	LF	\$/Unit	Total \$	REF:
CLT WALL	10', 3 layer panel	16000		\$ 10.79	\$ 172,640.00	1 Sub Quote
Stain/Finish	Wood Finishing	16000		\$ 3.14	\$ 50,240.00	1 Sub Quote
					\$ 222,880.00	SUB TOTAL
					\$ 1,528.96	0.69%
					\$ 111.44	0.05%
					\$ -	0 OWNER
					\$ -	0 OWNER
					\$ -	0 OWNER
					\$ -	0 OWNER
					\$ 3,343.20	1.50%
					\$ 10,029.60	4.50%
					\$ -	0
					\$ 237,893.20	TOTAL
					\$ 13.04	\$/SF ASSEMBLY

Business Tax .686%
 Additional Insurance
 Wrap Insurance Policy
 Builder's Risk Insurance @ 0.00%
 Design Contingency @ 0.00%
 Estimating Contingency @ 0.00%
 Contractor's Contingency @ 1.50%
 Overhead & Profit @ 4.00%
 Escalation @ 0.00%

COST: BID ANALYSIS

Steel

STEEL

(Supply, Install, Connections)

BID #1 – McClean Iron Works

$\$/\text{TON} = 2,500,000 \text{ (total price)} / (428.5\text{tons} + 42.85\text{tons}) = \mathbf{\$5,304 / ton}$

$\$/\text{SF Metal Deck} = 375,000 \text{ (total price)} / 115,155 = \mathbf{\$3.26 / SF}$

BID #2 – RF Stearns

Erection – $115,155(\text{SF TOTAL}) \times \$5 = \$575,775$. Detailing = $115,155 \times .5 = \$57,577.5$

$\$/\text{TON} = (575,775 + 57,577.5) / (428.5 + 42.85) = \$1,344/\text{ton install}$

$\$/\text{TON} = 1,344(\text{install}) + 2,200(\text{supply}) = \mathbf{\$3543.7 / ton}$

$\$/\text{SF Metal Deck?} = \$1.20?$ Does not include install, assume at least **\$3**

BID #3 – North Coast Ironworks

$\$/\text{TON} = \mathbf{\$4000 / Ton}$

$\$/\text{SF Metal Deck} = \mathbf{\$3}$

FINAL COSTS – AVERAGED – USE FOR BUDGET

$\$/\text{TON Supply \& Install} = (4000+3543.7+5304)/3 = \mathbf{\$4,282}$

$\$/\text{SF Metal Deck} = (3+3+3.26)/3 = \mathbf{\$3.09}$

$\$/\text{SF PT Deck} = \mathbf{\$50}$

COST: BID ANALYSIS

Concrete

CONCRETE

(Supply, Install, Rebar, Formwork, Equip)

BID #1 – Foundation Specialists

\$/CY concrete (general) = \$675.00

\$/CY Matt footing = Add \$10 a foot per 1 foot of height

Crane Pad = \$45,000

\$/SF Deck topping = $6.75 * 19,192.5 = 129,549.4 + (95,962.5 * 7.425) = 842,070$

\$/SF Deck = $842,070 / 115,155 = \$7.31/SF$ (includes metal decking) $7.31 - 3.09 =$

\$4.22/SF

COST: BID ANALYSIS

Wood

WOOD

(Supply only, see spreadsheets for install calc's)

BID#1 – Structurelam

\$/SF CLT = 21.60+.95 = **\$22.55/SF**

\$/SF CLT 3 ply = 9.84+.95 = **10.79/SF**

Glulam columns (10.75" x 18") 30ft - **\$1,389 EA**

Glulam columns (10.75" x 18") 20ft - **\$956 EA**

Glulam Girders (6.75" x 40.5") ~30 ft long - **\$1,962 EA**

BID #2 – Alki Lumber

Glulam columns (10.75" x 18") 30 ft long - **\$1,469.10 EA**

Glulam columns (10.75" x 18") 20 ft long - **\$734.55 EA**

Glulam Girders (6.75" x 40.5") ~30 ft long - **\$1,944.00 EA**

BID #3 – Matheus Lumber

Glulam columns (10.75" x 18") 30 ft long @ **\$745.20/ea**

Glulam columns (10.75" x 18") 20 ft long @ **\$372.60/ea**

Glulam Girders (6.75" x 40.5") ~30 ft long @ **\$1,039.20/ea**

Shipping - 11-12 trucks @ **\$600/truck** to account for the freight.

FINAL - AVERAGED

\$/SF CLT 7Ply= **\$22.55/SF**

\$/SF CLT 3Ply= **\$10.79/SF**

\$/28' Column = (1469.1 + 745.2 +1389) / 3 = **\$1201.10**

\$/15' Column = (734.55 + 372.6+956) / 3 = **\$687.72**

\$/Girder = (1944 + 1039.2+1962) / 3 = **\$1648.40**

Trucks = **\$600 EA**

COST: BID ANALYSIS

Finishes

FINISHES

(Supply, Install)

ACT – Story Acoustics

\$/SF = \$4.50

GYP & LGMF – Ketchikan Drywall

\$/LF GWB over columns = \$22.00/LF

\$/LF LGMF Wall = \$18.00/LF

\$/SF GWB = \$5.50/SF

FLOORING – Legacy Group

\$/SF Carpet tile = \$5/SF

FLOORING – Access Floor Systems

\$/SF Access Floor = \$10.80 (supply) + \$2 (install) = \$12.80/SF

PAINTING/FINISHING – Paint Smith Company

BID#1

\$/SF Interior Wall Paint = \$.80

\$/SF Wood Stained & Clear coated = \$3.50

BID#2

\$/SF Interior Wall Paint = \$2.39

\$/SF Wood Stained & Clear coated = \$2.80

FINAL COSTS

\$/SF Interior paint = $(2.39+.8)/2 = \$1.56/SF$

\$/SF Wood stain/coat = $(\$2.8+3.5)/2 = \$3.14/SF$

COST: BID ANALYSIS

Fire Proofing

FIRE PROOFING

(Supply, Install, Equip)

BID #1 – Anning-Johnson Company

$\$/SF = 1,080,000 / 115,155 = \$9.38/SF$

BID #2 – CGIUS

$\$/SF = 185,490 / 115,155 = \$1.60/SF$ assembly

FINAL COSTS

Based on cross referencing with other estimating guides based on $\$/BF$ of steel fireproofing, **$\$9.38/SF$** number will be used.

COST: QUANTITY TAKE-OFF

Schedule Exports from Revit

FLOORS				
Type	Comments	Area	Volume	Count
3" LW Concrete on 3" Metal Deck		4519 SF	2259.56 CF	1
3" LW Concrete on 3" Metal Deck		17246 SF	8622.96 CF	1
3" LW Concrete on 3" Metal Deck		17150 SF	8575.02 CF	1
3" LW Concrete on 3" Metal Deck		19582 SF	9791.02 CF	1
3" LW Concrete on 3" Metal Deck		17246 SF	8622.96 CF	1
3" LW Concrete on 3" Metal Deck		19586 SF	9792.93 CF	1
3" LW Concrete on 3" Metal Deck		17186 SF	8592.96 CF	1
: 7		112515 SF	56257.41 CF	
3" LW Concrete on 3" Metal Deck	Wood	4741 SF	2370.74 CF	1
3" LW Concrete on 3" Metal Deck	Wood	17246 SF	8622.96 CF	1
3" LW Concrete on 3" Metal Deck	Wood	17150 SF	8575.02 CF	1
3" LW Concrete on 3" Metal Deck	Wood	17246 SF	8622.96 CF	1
3" LW Concrete on 3" Metal Deck	Wood	19171 SF	9585.57 CF	1
3" LW Concrete on 3" Metal Deck	Wood	18020 SF	9010.05 CF	1
3" LW Concrete on 3" Metal Deck	Wood	19170 SF	9585.15 CF	1
Wood: 7		112745 SF	56372.45 CF	
3" LW Concrete on 3" Metal Deck: 14		225260 SF	112629.86 CF	
F1 - 4" SOG		20063 SF	6687.60 CF	1
: 1		20063 SF	6687.60 CF	
F1 - 4" SOG	Wood	20063 SF	6687.60 CF	1
Wood: 1		20063 SF	6687.60 CF	
F1 - 4" SOG: 2		40126 SF	13375.21 CF	
F2 - 12" Post-tensioned slab		11411 SF	11410.68 CF	1
F2 - 12" Post-tensioned slab		19628 SF	19628.03 CF	1
F2 - 12" Post-tensioned slab		2131 SF	2131.22 CF	1
F2 - 12" Post-tensioned slab		4212 SF	4212.44 CF	1
F2 - 12" Post-tensioned slab		1441 SF	1440.85 CF	1
: 5		38823 SF	38823.22 CF	
F2 - 12" Post-tensioned slab	Wood	11342 SF	11341.89 CF	1
F2 - 12" Post-tensioned slab	Wood	19628 SF	19628.03 CF	1
F2 - 12" Post-tensioned slab	Wood	2131 SF	2131.22 CF	1
F2 - 12" Post-tensioned slab	Wood	4212 SF	4212.44 CF	1
F2 - 12" Post-tensioned slab	Wood	1166 SF	1166.37 CF	1
Wood: 5		38480 SF	38479.94 CF	
F2 - 12" Post-tensioned slab: 10		77303 SF	77303.16 CF	

COST: QUANTITY TAKE-OFF

Schedule Exports from Revit

BEAMS & GIRDERS				
Type	Count	Length	Weight / LF	Total Weigl
6.75x40.5		93 4389' - 10 1/16"		1
CLT 7 Layer		126 11005' - 6 13/16"		1
W18X35		173 13278' - 3"		1
W18X60		60 2731' - 5 13/16"		1

COLUMNS				
Type	Comments	Count	Length	Volume
8.75x9	Wood		21 1968' - 0"	1076.25 CF
12 x 18	Steel		13 254' - 7"	381.88 CF
12 x 18	Wood		20 391' - 8"	587.50 CF
W14X176	Steel		12 1152' - 0"	412.60 CF

FOOTINGS				
	Comments	Count	Area	Volume
A1 - 10' 6" x 10' 6" x 42"			12 2205 SF	4630.50 CF
A1 - 10' 6" x 10' 6" x 42"	Wood		20 3675 SF	7717.50 CF
A1 - Bearing Footing - 48" x 36"			3 0 SF	4978.92 CF
A1 - Bearing Footing - 48" x 36"			1 0 SF	2084.48 CF
A1 - Bearing Footing - 48" x 36"	Wood		4 0 SF	7063.39 CF
A2 - Shear Wall Footing 4' Deep			1 6410 SF	23000.00 CF
A2 - Shear Wall Footing 4' Deep 2 W	Wood		1 6680 SF	24000.00 CF

COST: QUANTITY TAKE-OFF

Schedule Exports from Revit

WALLS				
Type	Comments	Length	Area	Volume
A1 - 12" Concrete		116' - 7 7/32"	2352 SF	2352.03 CF
A1 - 12" Concrete		177' - 8 15/32"	3376 SF	3226.43 CF
A1 - 12" Concrete		116' - 7 7/32"	2132 SF	2131.22 CF
A1 - 12" Concrete		43' - 2"	685 SF	685.17 CF
A1 - 12" Concrete		102' - 0"	10098 SF	10098.00 CF
A1 - 12" Concrete		177' - 8 15/32"	3534 SF	3534.13 CF
A1 - 12" Concrete		14' - 11 7/32"	1180 SF	1179.86 CF
: 7		748' - 8 5/8"	23357 SF	23206.85 CF
A1 - 12" Concrete		17' - 4 5/8"	347 SF	346.98 CF
: 1		17' - 4 5/8"	347 SF	346.98 CF
A1 - 12" Concrete	Wood	116' - 7 7/32"	2352 SF	2352.03 CF
A1 - 12" Concrete	Wood	177' - 8 15/32"	3376 SF	3226.43 CF
A1 - 12" Concrete	Wood	116' - 7 7/32"	2132 SF	2131.22 CF
A1 - 12" Concrete	Wood	102' - 0"	10098 SF	10098.00 CF
A1 - 12" Concrete	Wood	17' - 4 3/16"	347 SF	346.98 CF
A1 - 12" Concrete	Wood	177' - 8 15/32"	3357 SF	3357.42 CF
A1 - 12" Concrete	Wood	15' - 4 7/32"	1213 SF	1212.78 CF
Wood: 7		723' - 3 13/16"	22875 SF	22724.86 CF
A1 - 12" Concrete: 15		1489' - 5 1/16"	46579 SF	46278.69 CF
A2 - 8" Concrete		86' - 10"	566 SF	565.50 CF
A2 - 8" Concrete		75' - 6"	525 SF	525.00 CF
A2 - 8" Concrete		42' - 3 3/4"	330 SF	330.49 CF
: 3		204' - 7 3/4"	1421 SF	1420.99 CF
A2 - 8" Concrete	Wood	42' - 3 3/4"	330 SF	330.49 CF
Wood: 1		42' - 3 3/4"	330 SF	330.49 CF
A2 - 8" Concrete: 4		246' - 11 15/32"	1751 SF	1751.49 CF
Curtain Wall 1	Steel	168' - 6 3/16"	6721 SF	
Curtain Wall 1	Steel	42' - 3 3/4"	1692 SF	
Curtain Wall 1	Steel	9' - 8 9/32"	388 SF	
Curtain Wall 1	Steel	50' - 0"	2000 SF	
Curtain Wall 1	Steel	24' - 7 15/32"	985 SF	
Curtain Wall 1	Steel	178' - 2 15/32"	7108 SF	
Curtain Wall 1	Steel	168' - 6"	6048 SF	
Curtain Wall 1	Steel	107' - 6"	3870 SF	
Curtain Wall 1	Steel	168' - 6"	6066 SF	
Steel: 9		917' - 10 3/16"	34878 SF	0.00 CF
Curtain Wall 1	Wood	168' - 0"	6030 SF	
Curtain Wall 1	Wood	107' - 6"	3870 SF	
Curtain Wall 1	Wood	168' - 0"	6048 SF	
Curtain Wall 1	Wood	173' - 0 13/16"	6903 SF	

COST: QUANTITY TAKE-OFF

Schedule Exports from Revit

Curtain Wall 1	Wood	75' - 4 15/32"	3015 SF	
Curtain Wall 1	Wood	5' - 6"	220 SF	
Curtain Wall 1	Wood	42' - 0"	1680 SF	
Curtain Wall 1	Wood	167' - 6 13/16"	6703 SF	
Wood: 8		907' - 0 3/32"	34468 SF	0.00 CF
Curtain Wall 1: 17		1824' - 10 1/4"	69346 SF	0.00 CF
Generic - 6"		27' - 9 3/4"	542 SF	271.16 CF
Generic - 6"		33' - 0 3/4"	635 SF	317.48 CF
Generic - 6"		44' - 2 7/16"	864 SF	431.80 CF
Generic - 6"		34' - 0 1/16"	623 SF	311.29 CF
: 4		139' - 0 31/32"	2663 SF	1331.73 CF
Generic - 6"	Wood	27' - 9 13/32"	546 SF	272.83 CF
Generic - 6"	Wood	33' - 2 3/4"	648 SF	323.95 CF
Generic - 6"	Wood	42' - 0"	809 SF	404.50 CF
Wood: 3		103' - 0 5/32"	2003 SF	1001.28 CF
Generic - 6": 7		242' - 1 1/8"	4666 SF	2333.02 CF
Generic - 8"		11' - 4 23/32"	167 SF	111.27 CF
Generic - 8"		31' - 3 3/4"	3516 SF	2344.10 CF
Generic - 8"		31' - 3 3/4"	4106 SF	2737.43 CF
Generic - 8"		31' - 3 3/4"	3819 SF	2546.18 CF
Generic - 8"		31' - 3 3/4"	3819 SF	2546.18 CF
Generic - 8"		31' - 3 3/4"	3819 SF	2546.18 CF
Generic - 8"		31' - 3 3/4"	2888 SF	1925.50 CF
Generic - 8"		12' - 0"	1349 SF	899.11 CF
Generic - 8"		31' - 3 3/4"	3591 SF	2394.06 CF
Generic - 8"		10' - 0 3/32"	1111 SF	740.46 CF
Generic - 8"		10' - 0 3/32"	1191 SF	794.00 CF
Generic - 8"		7' - 9 3/32"	76 SF	50.61 CF
Generic - 8"		42' - 1 3/4"	413 SF	275.41 CF
Generic - 8"		12' - 0"	1235 SF	823.56 CF
Generic - 8"		65' - 1 23/32"	839 SF	559.53 CF
: 15		389' - 7 21/32"	31940 SF	21293.57 CF
Generic - 8"	Wood	43' - 2"	870 SF	580.00 CF
Generic - 8"	Wood	11' - 2 23/32"	195 SF	129.98 CF
Generic - 8"	Wood	31' - 3 3/4"	3516 SF	2344.10 CF
Generic - 8"	Wood	31' - 3 3/4"	4116 SF	2743.93 CF
Generic - 8"	Wood	31' - 3 3/4"	3819 SF	2546.18 CF
Generic - 8"	Wood	31' - 3 3/4"	3819 SF	2546.18 CF
Generic - 8"	Wood	31' - 3 3/4"	3819 SF	2546.18 CF
Generic - 8"	Wood	31' - 3 3/4"	2888 SF	1925.50 CF
Generic - 8"	Wood	12' - 0"	1349 SF	899.11 CF
Generic - 8"	Wood	31' - 3 3/4"	3601 SF	2400.56 CF
Generic - 8"	Wood	10' - 0 3/32"	1111 SF	740.46 CF
Generic - 8"	Wood	10' - 0 3/32"	1191 SF	794.00 CF
Generic - 8"	Wood	21' - 4 25/32"	191 SF	127.40 CF

COST: QUANTITY TAKE-OFF

Schedule Exports from Revit

Generic - 8"	Wood	42' - 1 3/4"	372 SF	247.87 CF
Generic - 8"	Wood	12' - 0"	1235 SF	823.56 CF
Generic - 8"	Wood	69' - 10"	904 SF	602.33 CF
Wood: 16		450' - 11 5/8"	32996 SF	21997.33 CF
Generic - 8": 31		840' - 7 9/32"	64936 SF	43290.90 CF
Generic - 8" - Filled		31' - 3 3/4"	3819 SF	2546.18 CF
Generic - 8" - Filled		17' - 10"	1632 SF	1088.00 CF
Generic - 8" - Filled		20' - 3 11/32"	1624 SF	1082.45 CF
Generic - 8" - Filled		20' - 3 11/32"	1867 SF	1244.50 CF
: 4		89' - 8 7/16"	8942 SF	5961.13 CF
Generic - 8" - Filled	Wood	31' - 3 3/4"	3819 SF	2546.18 CF
Generic - 8" - Filled	Wood	20' - 10 7/16"	1923 SF	1282.25 CF
Generic - 8" - Filled	Wood	21' - 3 11/32"	1707 SF	1138.12 CF
Generic - 8" - Filled	Wood	21' - 3 11/32"	1963 SF	1308.50 CF
Wood: 4		94' - 8 27/32"	9413 SF	6275.05 CF
Generic - 8" - Filled: 8		184' - 5 9/32"	18354 SF	12236.18 CF
Shear Wall 12"	Steel	39' - 10 3/32"	5017 SF	5017.30 CF
Shear Wall 12"	Steel	31' - 7 15/32"	3630 SF	3629.89 CF
Shear Wall 12"	Steel	39' - 11"	4914 SF	4912.62 CF
Shear Wall 12"	Steel	31' - 6 3/4"	3523 SF	3522.89 CF
Shear Wall 12"	Steel	42' - 9 31/32"	5116 SF	5116.00 CF
Shear Wall 12"	Steel	42' - 3 11/32"	5266 SF	5265.45 CF
Steel: 6		228' - 0 5/8"	27466 SF	27464.14 CF
Shear Wall 12"	Wood	42' - 10 17/32"	5385 SF	5384.80 CF
Shear Wall 12"	Wood	31' - 7 15/32"	3672 SF	3671.89 CF
Shear Wall 12"	Wood	42' - 10 17/32"	5279 SF	5278.58 CF
Shear Wall 12"	Wood	31' - 5 3/4"	3544 SF	3543.89 CF
Shear Wall 12"	Wood	43' - 9 31/32"	5223 SF	5223.00 CF
Shear Wall 12"	Wood	43' - 3 29/32"	5372 SF	5372.00 CF
Wood: 6		236' - 0 1/8"	28474 SF	28474.15 CF
Shear Wall 12": 12		464' - 0 3/4"	55940 SF	55938.29 CF
Storefront		17' - 4 3/16"	167 SF	
Storefront		60' - 1 5/32"	1167 SF	
Storefront		27' - 9 3/4"	533 SF	
Storefront		74' - 6"	1443 SF	
Storefront		27' - 6"	527 SF	
Storefront		39' - 4 25/32"	492 SF	
Storefront		64' - 8 7/32"	809 SF	
: 7		311' - 4 1/16"	5137 SF	0.00 CF
Storefront	Wood	17' - 4 3/16"	167 SF	
Storefront	Wood	72' - 6 1/32"	1450 SF	
Storefront	Wood	27' - 9 13/32"	546 SF	
Storefront	Wood	16' - 9 1/2"	326 SF	
Storefront	Wood	28' - 10 25/32"	376 SF	

COST: QUANTITY TAKE-OFF

Schedule Exports from Revit

Storefront	Wood	74' - 6"	1480 SF	
Storefront	Wood	64' - 8 7/32"	841 SF	
Wood: 7		302' - 6 1/8"	5185 SF	0.00 CF
Storefront: 14		613' - 10 3/16"	10322 SF	0.00 CF

COST: CREDITS

Solicited Subcontractors

Steel

McClellan Iron Works - Richard McClellan

RF Stearns - Carey Lee

North Coast Ironworks - Kent Schluter

Wood

Structurelam - Kris Spickler

Alki Lumber - Bill Boender

Matheus Lumber - Dave Neiger

Concrete

Foundation Specialists - Thomas J Cook

Finishes

Story Acoustics - Tony Wood

Ketchikan Drywall - Ulises Morales

Legacy Group - Dave Spannaus

Access Floor Systems - Tate Web Quote

Paint Smith Company - Justin Smith

Sound Painting Solutions - Jeff Dupont

Other

Anning-Johnson Company - Curtis L. Dunbar

CGIUS - George Bruce

See APPENDIX A for all subcontractor quotes.

CHAPTER SIX:

Schedule



Schedule Guidelines/Assumptions:

- Two 250+ item schedules were developed for both baseline options.
- The developed schedules center on construction time only, and exclude preconstruction and permitting times
- Both schedules were developed using quantities out of Revit and productivity rates and crew compositions from RS Means
- Although schedules were developed for both projects, conversations were had with superintendents of construction companies to gauge their opinions on the potential schedule impacts of both options.

SCHEDULE: SUMMARY SCHEDULE

Total Duration Comparison by Category

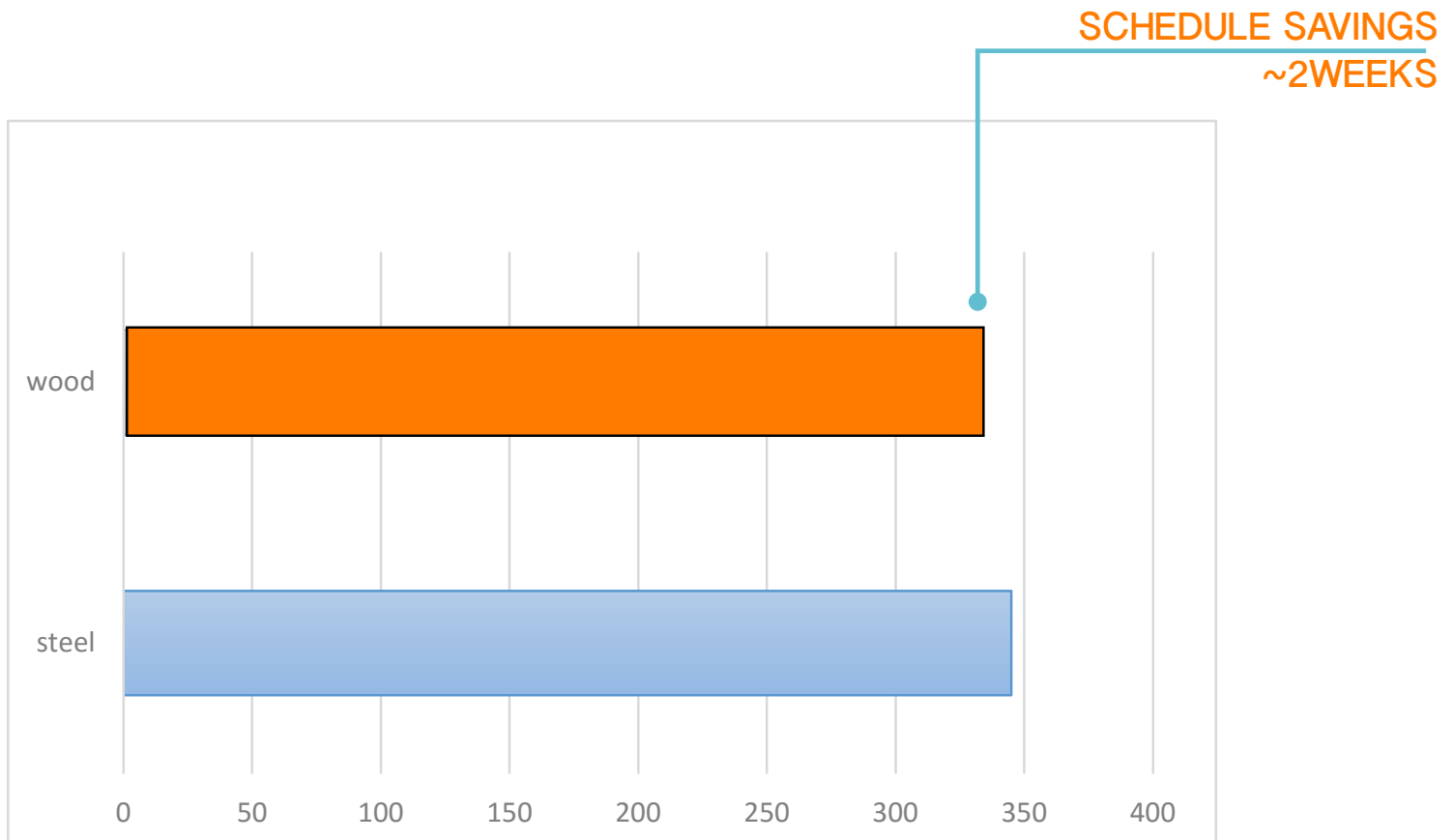

The results of the generated schedules reveal a surprisingly small schedule savings when switching to a wood structural system. The generated schedules do not see a significant improvement in the overall project time, because although there are fewer elements in the wood system, these elements are not critical path items. A critical path item is one which impacts the overall schedule time based on the logic and sequencing of the activities. Therefore, because most critical path items were similar for both options, the overall schedule was very similar. In all, the total construction time for both options ranged between 14 and 14.5 months.

Conversations with superintendents confirm the results of this study. A large schedule savings by switching to a wood structure was not anticipated by any of the experts. In fact, several experts mentioned that a taller, or high rise building with 20-30 stories would perform best with a steel structure. This is because there can be more overlap of activities from one floor to the next with the steel option than with other construction types. This overlap, as the number of stories increase, produces an overall shorter construction sequence. However, for a building only 7 stories tall, the construction times for both would be about the same. One of the primary scheduling difficulties with wood is that the weight of each CLT panel requires crane time to be lifted and hoisted into place. With the steel option, however, metal decking for the floors can be flown in as a bundle by the crane and then set by hand because it is more lightweight. This means that the crane in the steel building will be able to continue lifting and placing the floors above while the decking is being placed. With wood, on the other hand, the weight of the panel requires each panel to be crane placed, so the next floors cannot be erected until at least half of the floor below is complete.

SCHEDULE: SUMMARY SCHEDULE

Total Duration Comparison by Category

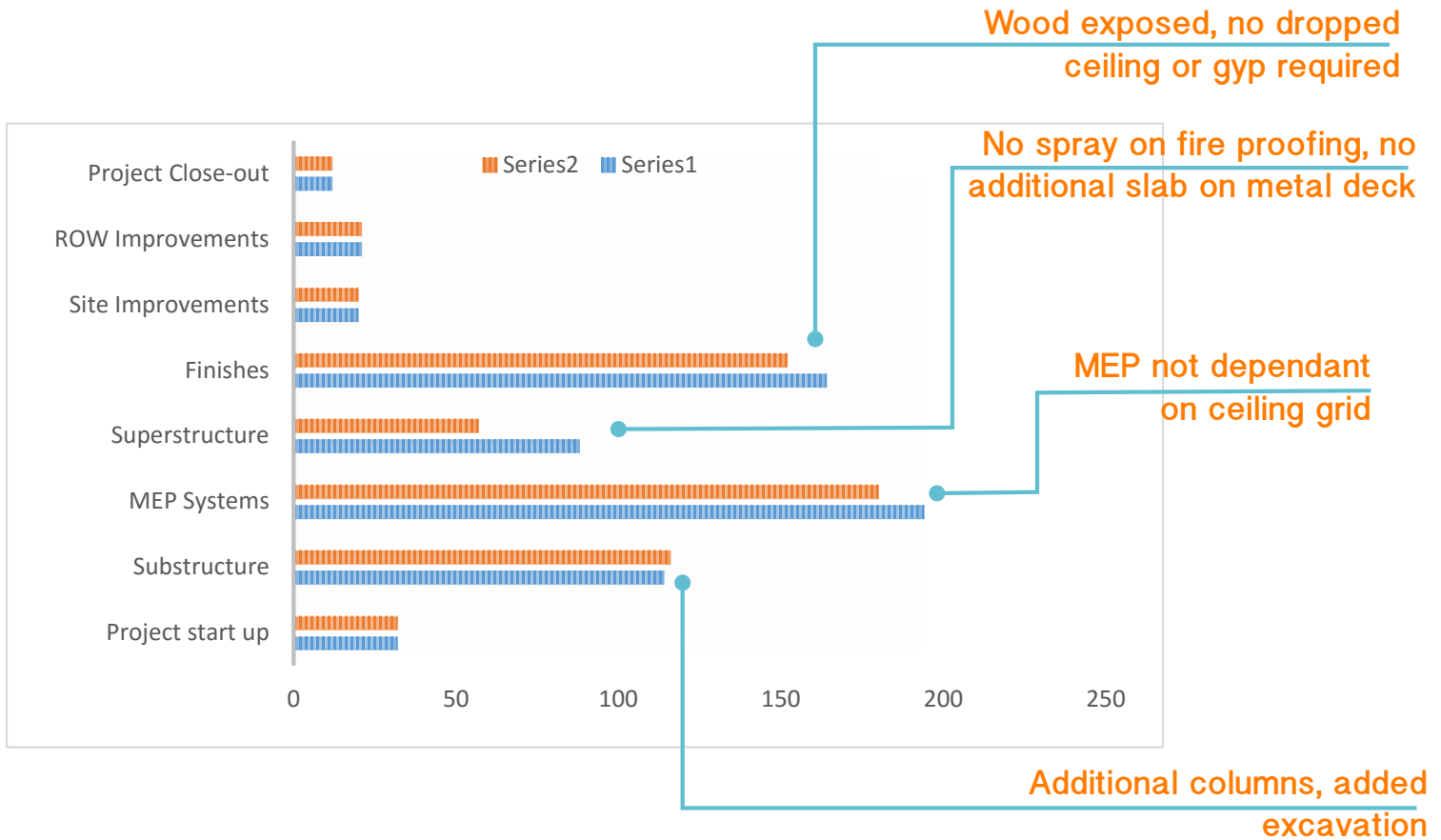

Above is a graph showing the scheduling differences by category for the wood and steel options as generated by the 250+ items schedules. Project Executive Tim O'Neil with Skanska and Superintendent Bruce Macauley with PCL suggest the following for the two options:

Foundations:

- **3-4 months** for excavation, shoring and concrete up to level 1

Superstructure:

- **WOOD - 5 to 10 days per floor, 1.5-2months.** This rate assumes floors can be overlapped

- **STEEL - 8 - 12 weeks total.** With floor overlap

Finishes to closeout:

- **5-6 months total.** This includes curtain wall, interior finishes, sitework, MEP and closeout activities.

SCHEDULE: SUMMARY SCHEDULE

Total Duration Comparison by Category

ID	Task Mod	Task Name	Duration	Start	Finish	Predecessors	Resource Names	July 15/16	July 21/16	January 1/17	June 11/17	November 11/17	May 4/23
1		Steel & Concrete	345 days	Tue 11/3/15	Mon 2/27/17								
2		Project Start Up	32 days	Tue 11/3/15	Wed 12/16/15								
7		Substructure	114 days	Thu 12/17/15	Tue 5/24/16								
99		MEP Systems	194 days	Mon 5/16/16	Thu 2/9/17								
42		Superstructure	88 days	Wed 5/25/16	Fri 9/23/16								
160		Finishes	164 days	Tue 6/14/16	Fri 1/27/17								
245		Site Improvements	20 days	Fri 11/25/16	Thu 12/22/16								
255		ROW Improvements	21 days	Mon 11/28/16	Mon 12/26/16								
266		Close-out	12 days	Fri 2/10/17	Mon 2/27/17								

ID	Task Mod	Task Name	Duration	Start	Finish	Predecessors	September 8/16	November 9/20	February 10/25	April 11/13	June 21/17	September 9/4	November 11/13	January 2/18
1		Wood & Concrete	333 days	Tue 11/3/15	Thu 2/9/17									
2		Project Start Up	32 days	Tue 11/3/15	Wed 12/16/15									
7		Substructure	116 days	Thu 12/17/15	Thu 5/26/16									
91		MEP Systems	180 days	Wed 5/18/16	Tue 1/24/17									
42		Superstructure	57 days	Fri 5/27/16	Mon 8/15/16									
152		Finishes	152 days	Tue 6/14/16	Wed 1/11/17									
223		Site Improvements	20 days	Mon 11/21/16	Fri 12/16/16									
233		ROW Improvements	21 days	Tue 11/22/16	Tue 12/20/16									
244		Close-out	12 days	Wed 1/25/17	Thu 2/9/17									

Shown above are the summary schedules as developed using Microsoft Project and RS Means productivity rates.

SCHEDULE: DETAILED ITEM SCHEDULES

Steel & Concrete

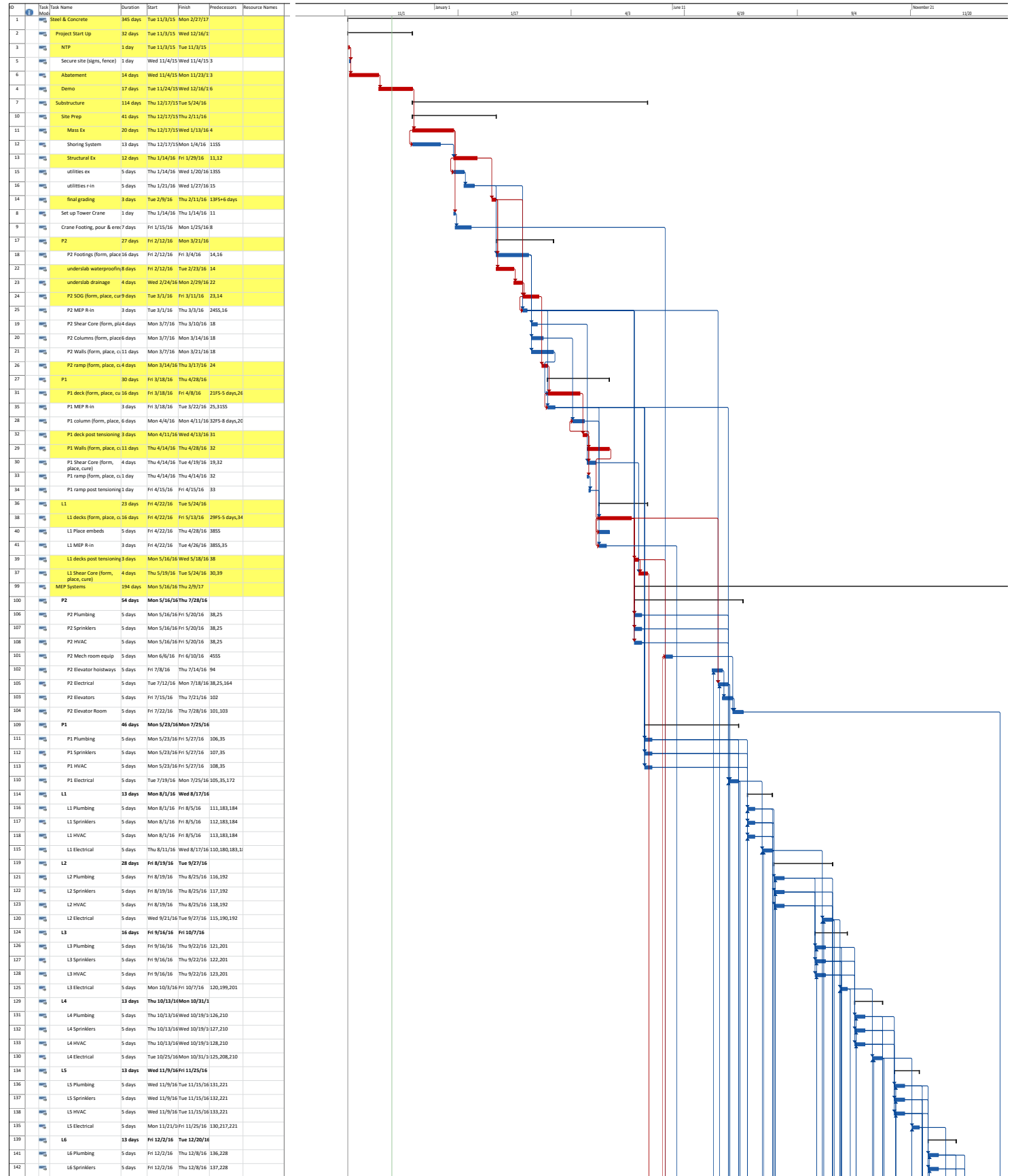

SCHEDULE: DETAILED ITEM SCHEDULES

Steel & Concrete

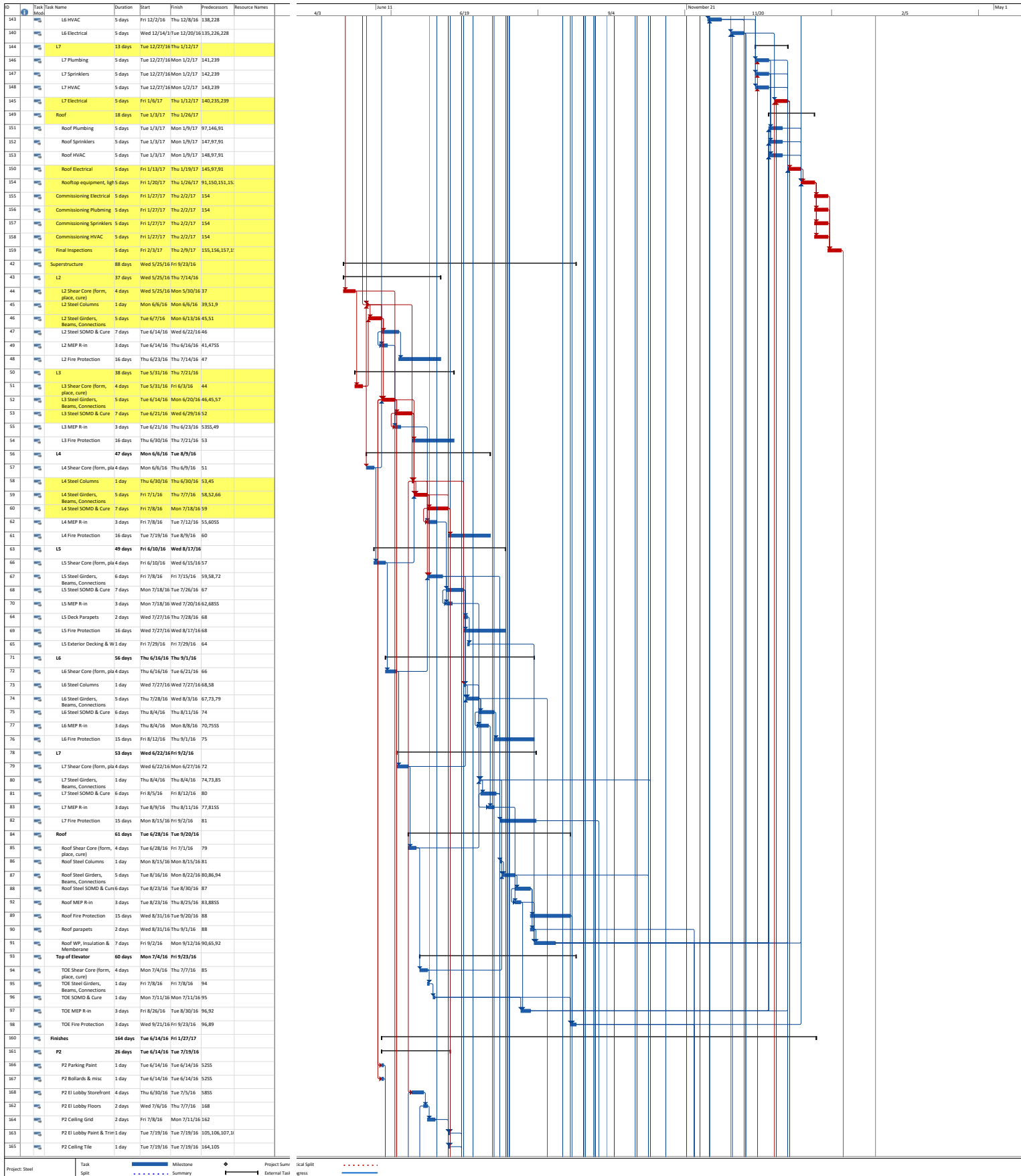

SCHEDULE: DETAILED ITEM SCHEDULES

Steel & Concrete

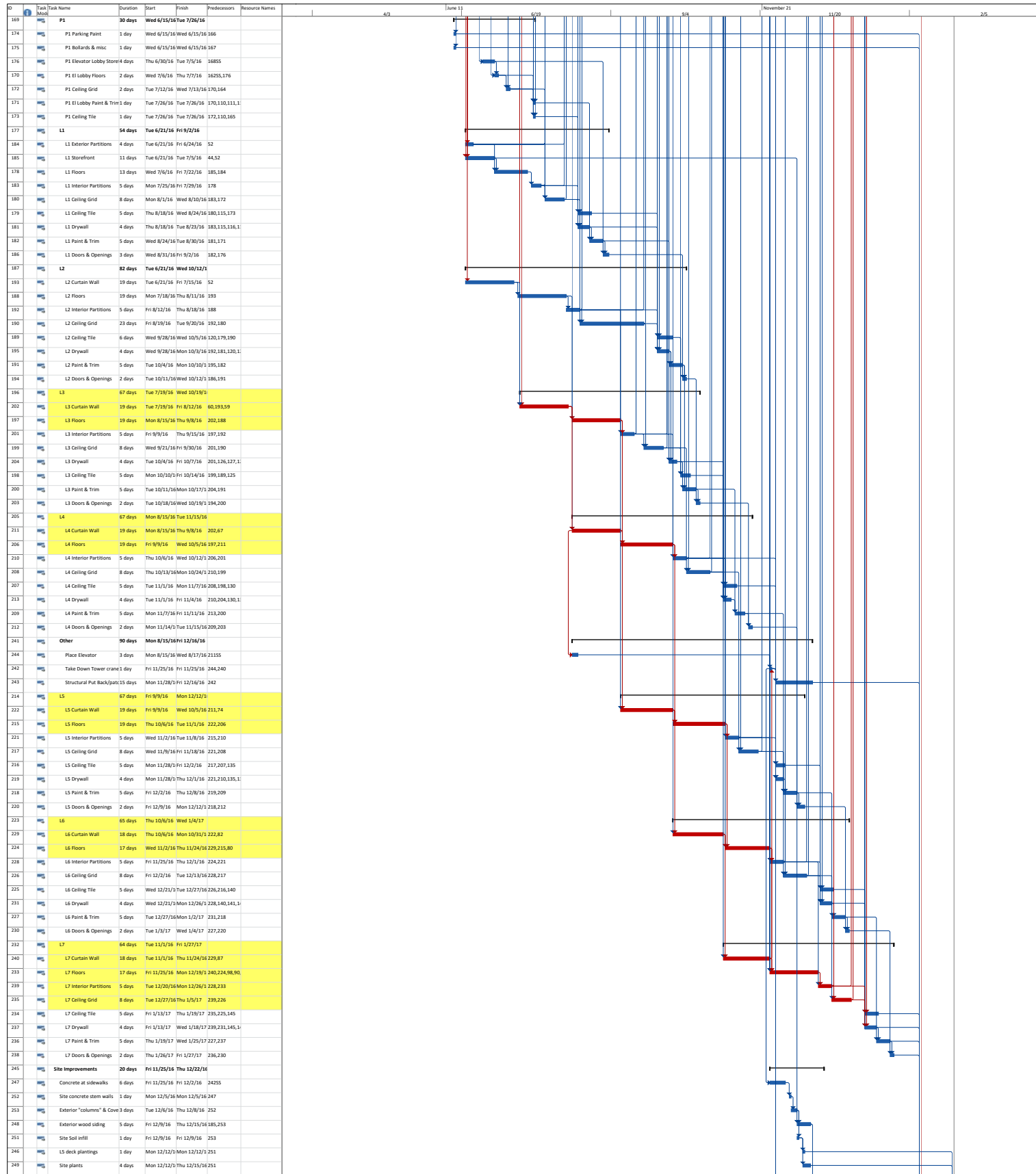

SCHEDULE: DETAILED ITEM SCHEDULES

Steel & Concrete

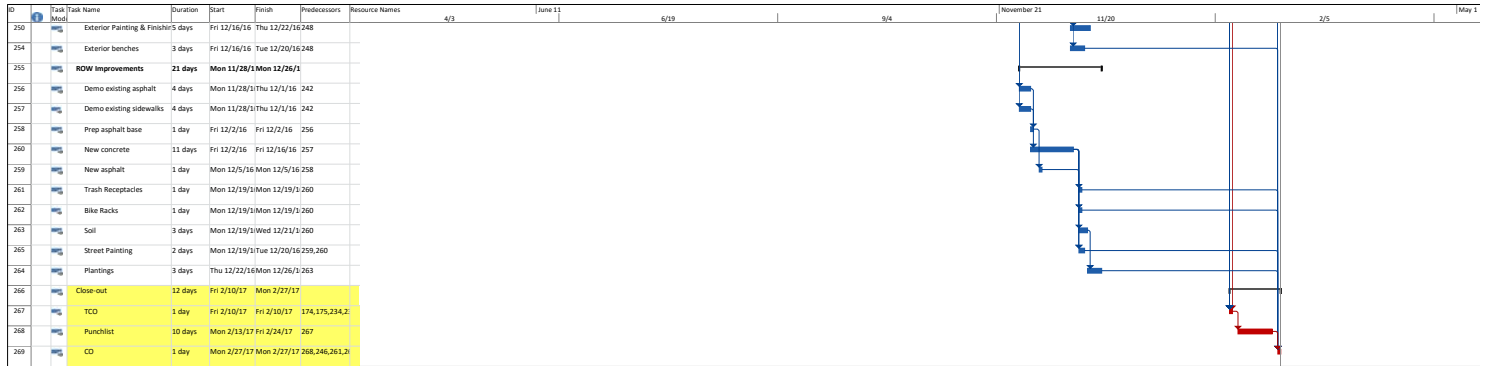

SCHEDULE: DETAILED ITEM SCHEDULES

Wood & Concrete

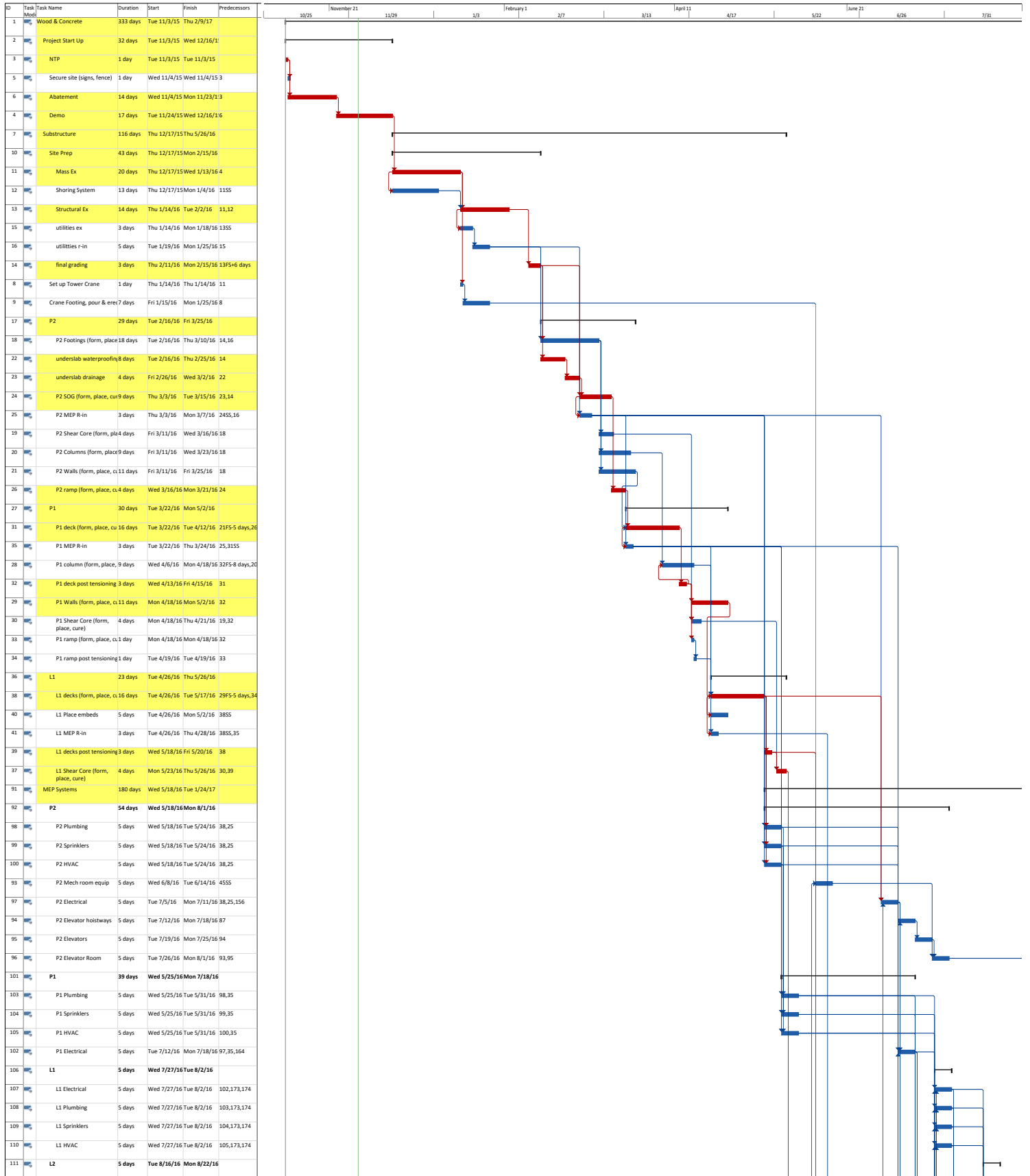

SCHEDULE: DETAILED ITEM SCHEDULES

Wood & Concrete

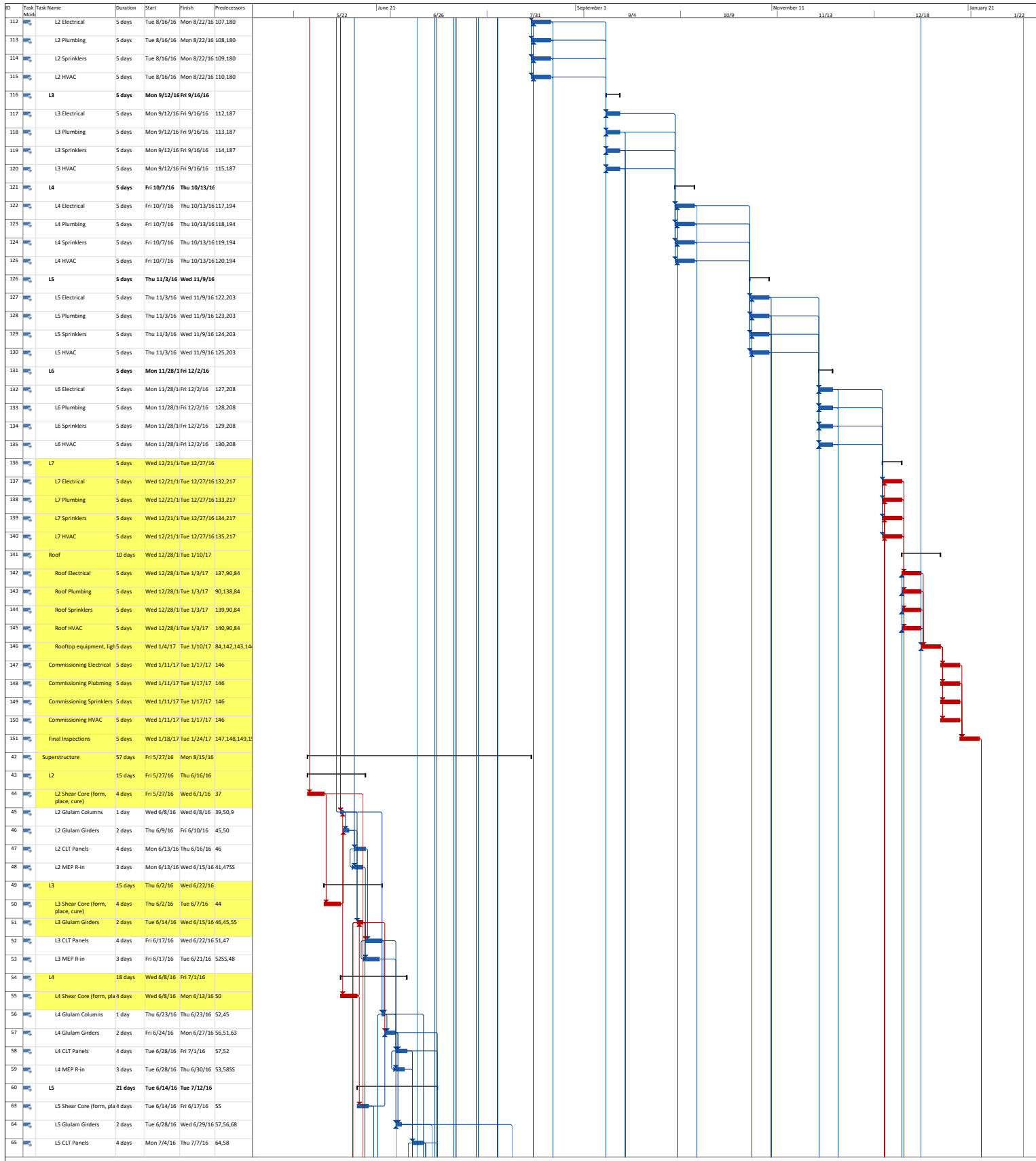

SCHEDULE: DETAILED ITEM SCHEDULES

Wood & Concrete

ID	Task Name	Duration	Start	Finish	Predecessors
66	L5 MEP R-in	3 days	Mon 7/4/16	Wed 7/6/16	59,65,55
61	L5 Deck Parapets	2 days	Fri 7/8/16	Mon 7/12/16	65
62	L5 Exterior Decking & W/1	1 day	Tue 7/12/16	Tue 7/12/16	61
67	L6	21 days	Mon 6/20/16	Mon 7/18/16	
68	L6 Shear Core (form, pla	4 days	Mon 6/20/16	Thu 6/23/16	63
69	L6 Glulam Columns	1 day	Fri 7/8/16	Fri 7/8/16	65,56
70	L6 Glulam Girders	2 days	Mon 7/11/16	Tue 7/12/16	64,69,74
71	L6 CLT Panels	4 days	Wed 7/13/16	Mon 7/18/16	70,65
72	L6 MEP R-in	3 days	Wed 7/13/16	Fri 7/15/16	66,75,55
73	L7	21 days	Fri 6/24/16	Fri 7/22/16	
74	L7 Shear Core (form, pla	4 days	Fri 6/24/16	Wed 6/29/16	68
75	L7 Glulam Girders	2 days	Wed 7/13/16	Thu 7/14/16	70,69,79
76	L7 CLT Panels	4 days	Tue 7/19/16	Fri 7/22/16	75,71
77	L7 MEP R-in	3 days	Tue 7/19/16	Thu 7/21/16	72,76,55
78	Roof	33 days	Thu 6/30/16	Mon 8/15/16	
79	Roof Shear Core (form, place, cure)	4 days	Thu 6/30/16	Tue 7/5/16	74
80	Roof Glulam Columns	1 day	Mon 7/25/16	Mon 7/25/16	76
81	Roof Glulam Girders	2 days	Tue 7/26/16	Wed 7/27/16	75,80,87
82	Roof CLT Panels	4 days	Thu 7/28/16	Tue 8/2/16	81,76
85	Roof MEP R-in	3 days	Thu 7/28/16	Mon 8/1/16	77,82,55
83	Roof parapets	2 days	Wed 8/3/16	Thu 8/4/16	82
84	Roof WP, Insulation & Membrane	7 days	Fri 8/5/16	Mon 8/15/16	83,62,85
86	Top of Elevator	24 days	Wed 7/6/16	Mon 8/8/16	
87	TOE Shear Core (form, place, cure)	4 days	Wed 7/6/16	Mon 7/11/16	79
88	TOE Glulam Girders	1 day	Tue 7/12/16	Tue 7/12/16	87
89	TOE CLT Panels	1 day	Wed 8/3/16	Wed 8/3/16	88,82
90	TOE MEP R-in	3 days	Thu 8/4/16	Mon 8/8/16	89,85
152	Finishes	152 days	Tue 6/14/16	Wed 1/11/17	
153	P2	21 days	Tue 6/14/16	Tue 7/12/16	
158	P2 Parking Paint	1 day	Tue 6/14/16	Tue 6/14/16	51,55
159	P2 Bollards & misc	1 day	Tue 6/14/16	Tue 6/14/16	51,55
160	P2 EI Lobby Storefront	4 days	Thu 6/23/16	Tue 6/28/16	56,55
154	P2 EI Lobby Floors	2 days	Wed 6/29/16	Thu 6/30/16	160
156	P2 Ceiling Grid	2 days	Fri 7/1/16	Mon 7/4/16	154
155	P2 EI Lobby Paint & Trim	1 day	Tue 7/12/16	Tue 7/12/16	97,98,99,100
157	P2 Ceiling Tile	1 day	Tue 7/12/16	Tue 7/12/16	156,97
161	P1	25 days	Wed 6/15/16	Tue 7/19/16	
166	P1 Parking Paint	1 day	Wed 6/15/16	Wed 6/15/16	158
167	P1 Bollards & misc	1 day	Wed 6/15/16	Wed 6/15/16	159
168	P1 Elevator Lobby Store	4 days	Thu 6/23/16	Tue 6/28/16	160,55
162	P1 EI Lobby Floors	2 days	Wed 6/29/16	Thu 6/30/16	154,55,168
164	P1 Ceiling Grid	2 days	Tue 7/5/16	Wed 7/6/16	162,156
163	P1 EI Lobby Paint & Trim	1 day	Tue 7/19/16	Tue 7/19/16	162,102,103,1
165	P1 Ceiling Tile	1 day	Tue 7/19/16	Tue 7/19/16	164,102,157
169	L1	46 days	Thu 6/16/16	Thu 8/18/16	
174	L1 Exterior Partitions	4 days	Thu 6/16/16	Tue 6/21/16	51
175	L1 Storefront	11 days	Thu 6/16/16	Thu 6/30/16	44,51
170	L1 Floors	13 days	Fri 7/1/16	Tue 7/19/16	175,174
173	L1 Interior Partitions	5 days	Wed 7/20/16	Tue 7/26/16	170
171	L1 Drywall	4 days	Wed 8/3/16	Mon 8/8/16	173,107,108,1
172	L1 Paint & Trim	5 days	Tue 8/9/16	Mon 8/15/16	171,163
176	L1 Doors & Openings	3 days	Tue 8/16/16	Thu 8/18/16	172,168
177	L2	59 days	Thu 6/16/16	Tue 9/6/16	
181	L2 Curtain Wall	19 days	Thu 6/16/16	Tue 7/12/16	51
178	L2 Floors	19 days	Wed 7/13/16	Mon 8/8/16	181
180	L2 Interior Partitions	5 days	Tue 8/9/16	Mon 8/15/16	178
183	L2 Drywall	4 days	Tue 8/23/16	Fri 8/26/16	180,171,112,1
179	L2 Paint & Trim	5 days	Mon 8/29/16	Fri 9/2/16	183,172
182	L2 Doors & Openings	2 days	Mon 9/5/16	Tue 9/6/16	176,179
184	L3	59 days	Wed 7/13/16	Mon 10/3/16	
188	L3 Curtain Wall	19 days	Wed 7/13/16	Mon 8/8/16	58,181,57
185	L3 Floors	19 days	Tue 8/9/16	Fri 9/2/16	188,178

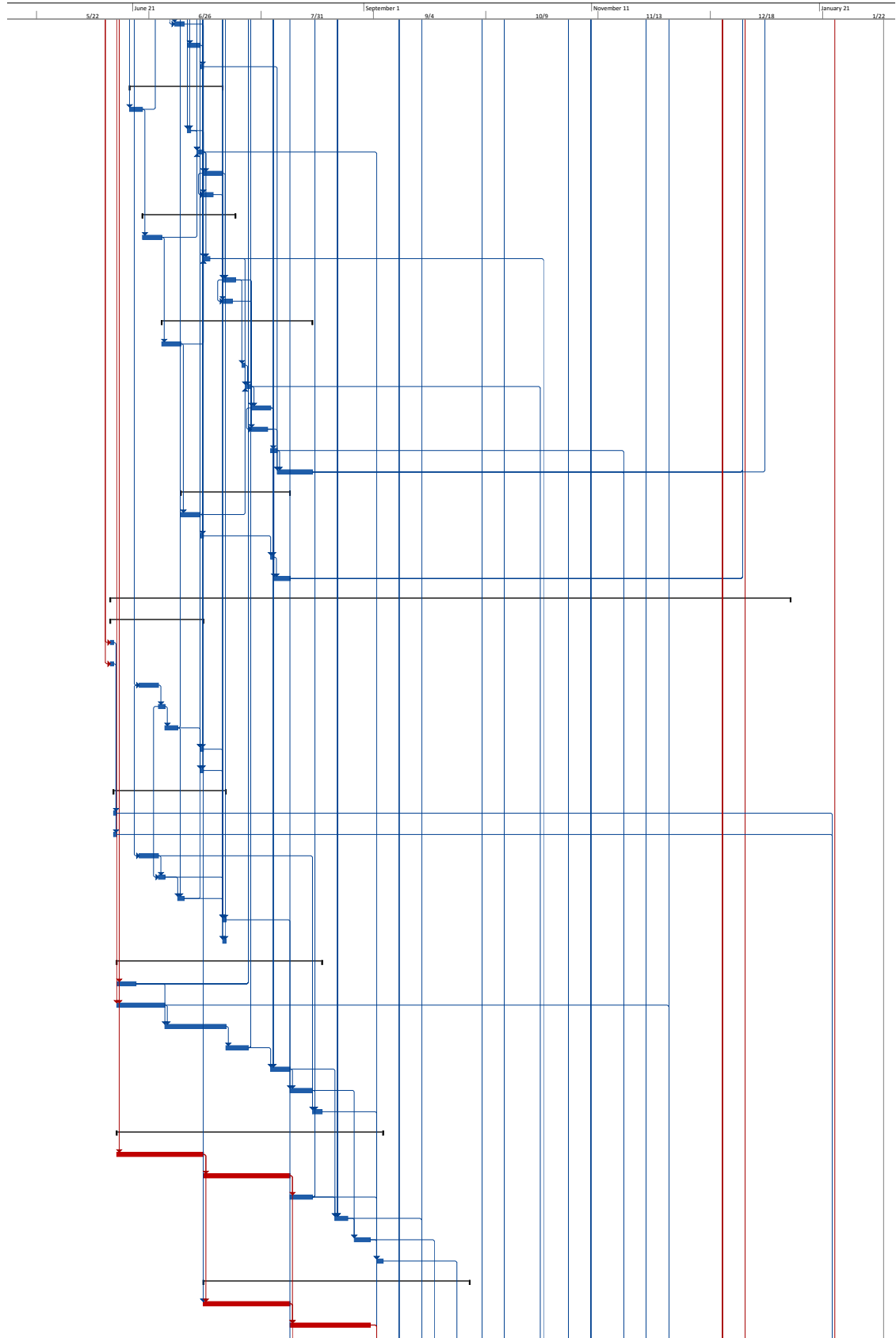

Project: Wood | Task Split | Milestone Summary

Critical Split | Progress

SCHEDULE: DETAILED ITEM SCHEDULES

Wood & Concrete

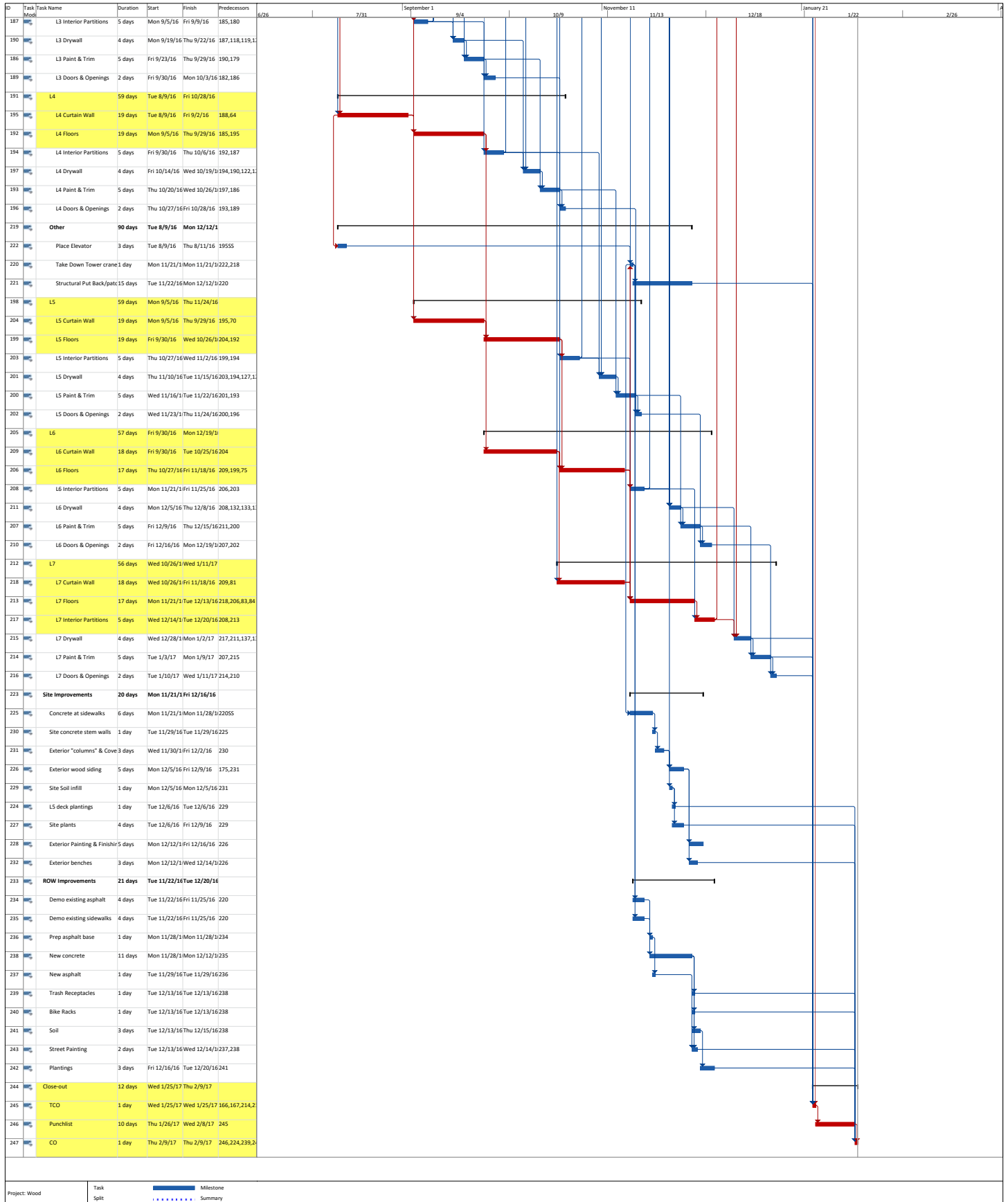

SCHEDULE: PRODUCTIVITY ANALYSIS

Productivity rates for tasks

Item	QTY	Unit	MH/QTY	Total MH	MH/Crew	# Days	Ref
Steel & Concrete							
NTP	1	Day	8	8	8	1	General
Demo	259200	CF	0.003	777.6	48	16.2	RSM 02.41.16.15 01
Abatement	4000	BCY	0.04	160	12	13.33333	RSM 02.56.13 0200
Substructure							
Site Prep							
Mass Ex	16000	BCY	0.02	320	16	20	RSM 31.23.16.42 02
Shoring System	12000	SF	0.067	804	64	12.5625	RSM 31.41.15.10 15
Structural Ex	1286	BCY	0.148	190.328	16	11.8955	RSM 31.23.16.42 60
utilities ex	1200	LF	0.018	21.6	8	2.7	RSM 31.23.16.14 06
final grading	2400	SY	0.015	36	16	2.25	RSM31.22.16.10 11
utilitties r-in	21600	SF	0.003	64.8	16	4.05	ROM
P2							
P2 Footings (form, place, cure)	1161	CY	1.493	1733.373	112	15.47654	RSM 03.30.53.40 38
underslab waterproofing	21600	SF	0.019	410.4	56	7.328571	RSM 07.12.13.20 00
P2 Shear Core (form, place cure)	107.9	CY	7.377	795.9783	200	3.979892	RSM 03.30.53.40 42
P2 Columns (form, place, cure)	66.66667	CY	15.911	1060.733	200	5.303667	RSM 03.30.53.40 08
P2 Walls (form, place, cure)	416	CY	4.999	2079.584	200	10.39792	RSM 03.30.53.40 42
underslab drainage	264	CY	0.111	29.304	8	3.663	RSM 03.05.13.25 10
P2 SOG (form, place, cure)	21600	SF	0.021	453.6	56	8.1	RSM 03.30.53.40 31
P2 MEP R-in	3	Days	8	24	8	3	ROM
P2 ramp (form, place, cure)	153.8519	CY	4.079	627.5617	208	3.017124	RSM 03.30.53.40 19
P2 ramp post tensioning	1	Day	8	8	8	1	ROM
P1							
P1 deck (form, place, cure)	800	CY	4.079	3263.2	208	15.68846	RSM 03.30.53.40 19
P1 MEP R-in	3	Days	8	24	8	3	ROM
P1 deck post tensioning	1	Days	8	8	1	8	ROM
P1 column (form, place, cure)	66.66667	CY	15.911	1060.733	200	5.303667	RSM 03.30.53.40 08
P1 Walls (form, place, cure)	416	CY	4.999	2079.584	200	10.39792	RSM 03.30.53.40 42
P1 Shear Core (form, place, cure)	107.9	CY	7.377	795.9783	200	3.979892	RSM 03.30.53.40 42
P1 ramp (form, place, cure)	50.57074	CY	4.079	206.2781	208	0.991721	RSM 03.30.53.40 19
P1 ramp post tensioning	1	Days	8	8	1	8	ROM
L1							
L1 decks (form, place, cure)	800	CY	4.079	3263.2	208	15.68846	RSM 03.30.53.40 19
L1 Place embeds	5	Days	8	40	8	5	ROM
L1 MEP R-in	3	Days	8	24	8	3	ROM
L1 decks post tensioning	1	Days	8	8	1	8	ROM
L1 Shear Core (form, place, cure)	107.9	CY	7.377	795.9783	200	3.979892	RSM 03.30.53.40 42
Superstructure							
Set up towercrane	3	Days	8	24	8	3	ROM
L2							
L2 Steel Columns	408	LF	0.061	24.888	56	0.444429	RSM 05.12.23.17 74
L2 Shear Core (form, place, cure)	107.9	CY	7.377	795.9783	200	3.979892	RSM 03.30.53.40 42
L2 Steel Girders, Beams, Connections	2399	LF	0.102	244.698	56	4.369607	RSM 05.12.23.75 09
L2 Steel SOMD & Cure	19219	SF	0.01	192.19	32	6.005938	RSM 05.31.13.50 57
L2 MEP R-in	3	Days	8	24	8	3	ROM
L2 Fire P	19219	SF	0.019	365.161	24	15.21504	RSM 07.81.16.20 04
L3							
L3 Shear Core (form, place, cure)	107.9	CY	7.377	795.9783	200	3.979892	RSM 03.30.53.40 42
L3 Steel Girders, Beams, Connections	2399	LF	0.102	244.698	56	4.369607	RSM 05.12.23.75 09
L3 Steel SOMD & Cure	19219	SF	0.01	192.19	32	6.005938	RSM 05.31.13.50 57

SCHEDULE: PRODUCTIVITY ANALYSIS

Productivity rates for tasks

L3 MEP R-in	3	Days	8	24	8	3	ROM
L3 Fire P	19219	SF	0.019	365.161	24	15.21504	RSM 07.81.16.20 04
L4							
L4 Shear Core (form, place, cure)	107.9	CY	7.377	795.9783	200	3.979892	RSM 03.30.53.40 42
L4 Steel Columns	336	LF	0.061	20.496	56	0.366	RSM 05.12.23.17 74
L4 Steel Girders, Beams, Connections	2399	LF	0.102	244.698	56	4.369607	RSM 05.12.23.75 09
L4 Steel SOMD & Cure	19219	SF	0.01	192.19	32	6.005938	RSM 05.31.13.50 57
L4 MEP R-in	3	Days	8	24	8	3	ROM
L4 Fire P	19219	SF	0.019	365.161	24	15.21504	RSM 07.81.16.20 04
L5							
L5 Shear Core (form, place, cure)	107.9	CY	7.377	795.9783	200	3.979892	RSM 03.30.53.40 42
L5 Steel Girders, Beams, Connections	2399	LF	0.102	244.698	56	4.369607	RSM 05.12.23.75 09
L5 Steel SOMD & Cure	19219	SF	0.01	192.19	32	6.005938	RSM 05.31.13.50 57
L5 MEP R-in	3	Days	8	24	8	3	ROM
L5 Fire P	19219	SF	0.019	365.161	24	15.21504	RSM 07.81.16.20 04
L6							
L6 Shear Core (form, place, cure)	107.9	CY	7.377	795.9783	200	3.979892	RSM 03.30.53.40 42
L6 Steel Columns	336	LF	0.061	20.496	56	0.366	RSM 05.12.23.17 74
L6 Steel Girders, Beams, Connections	2399	LF	0.102	244.698	56	4.369607	RSM 05.12.23.75 09
L6 Steel SOMD & Cure	18036	SF	0.01	180.36	32	5.63625	RSM 05.31.13.50 57
L6 MEP R-in	3	Days	8	24	8	3	ROM
L6 Fire P	18036	SF	0.019	342.684	24	14.2785	RSM 07.81.16.20 04
L7							
L7 Shear Core (form, place, cure)	107.9	CY	7.377	795.9783	200	3.979892	RSM 03.30.53.40 42
L7 Steel Girders, Beams, Connections	2399	LF	0.102	244.698	56	4.369607	RSM 05.12.23.75 09
L7 Steel SOMD & Cure	18036	SF	0.01	180.36	32	5.63625	RSM 05.31.13.50 57
L7 MEP R-in	3	Days	8	24	8	3	ROM
L7 Fire P	18036	SF	0.019	342.684	24	14.2785	RSM 07.81.16.20 04
Roof							
Roof Shear Core (form, place, cure)	107.9	CY	7.377	795.9783	200	3.979892	RSM 03.30.53.40 42
Roof Steel Columns	168	LF	0.061	10.248	56	0.183	RSM 05.12.23.17 74
Roof Steel Girders, Beams, Connections	2399	LF	0.102	244.698	56	4.369607	RSM 05.12.23.75 09
Roof Steel SOMD & Cure	18036	SF	0.01	180.36	32	5.63625	RSM 05.31.13.50 57
Roof MEP R-in	3	Days	8	24	8	3	ROM
Roof Fire P	18036	SF	0.019	342.684	24	14.2785	RSM 07.81.16.20 04
Top of Elevator							
TOE Shear Core (form, place, cure)	107.9	CY	7.377	795.9783	200	3.979892	RSM 03.30.53.40 42
TOE Steel Girders, Beams, Connections	40	LF	0.102	4.08	56	0.072857	RSM 05.12.23.75 09
TOE SOMD & Cure	2654	SF	0.01	26.54	32	0.829375	RSM 05.31.13.50 57
TOE MEP R-in	3	Days	8	24	8	3	ROM
TOE Fire P	2654	SF	0.019	50.426	24	2.101083	RSM 07.81.16.20 04
MEP Systems							
P2							
P2 Plumbing	10	Days	8	80	8	10	ROM
P2 Sprinklers	10	Days	8	80	8	10	ROM
P2 HVAC	10	Days	8	80	8	10	ROM
P2 Mech room equip	5	Days	8	40	8	5	ROM

SCHEDULE: PRODUCTIVITY ANALYSIS

Productivity rates for tasks

P2 El Lobby Floors	525	SF	0.025	13.125	8	1.640625	RSM 09.65.33.10 18
P2 Ceiling Grid	1.05	500 SF	8	8.4	8	1.05	Story Acoustics
P2 Parking Paint	2400	LF	0.003	7.2	40	0.18	RSM 32.17.23.13 07
P2 Bollards & misc	5	EA	2.4	12	24	0.5	RSM 34.71.13.17 27
P2 El Lobby Paint & Trim	600	SF	0.012	7.2	8	0.9	RSM 09.91.23.52 39
P2 Ceiling Tile	0.65625	800 SF	8	5.25	8	0.65625	Story Acoustics
P1							
P1 Elevator Lobby Storefront	360	SF	0.171	61.56	16	3.8475	RSM 08.41.19.10 00
P1 El Lobby Floors	525	SF	0.025	13.125	8	1.640625	RSM 08.41.19.10 00
P1 Ceiling Grid	1.05	500 SF	8	8.4	8	1.05	Story Acoustics
P1 Parking Paint	2400	LF	0.003	7.2	40	0.18	RSM 32.17.23.13 07
P1 Bollards & misc	5	EA	2.4	12	24	0.5	RSM 34.71.13.17 27
P1 El Lobby Paint & Trim	600	SF	0.012	7.2	8	0.9	RSM 09.91.23.52 39
P1 Ceiling Tile	0.65625	800 SF	8	5.25	8	0.65625	Story Acoustics
L2							
L2 Curtain Wall	5859	SF	0.178	1042.902	56	18.62325	RSM 08.44.13.10 07
L2 Floors	19219	SF	0.03	576.57	32	18.01781	RSM 09.69.13.10 07
L2 Interior Partitions	2800	SF	0.046	128.8	16	5	RSM 09.21.16.33 10
L2 Ceiling Grid	38.438	500 SF	8	307.504	40	7.6876	Story Acoustics
L2 Ceiling Tile	24.02375	800 SF	8	192.19	40	4.80475	Story Acoustics
L2 Drywall	2800	SF	8	22400	above	4	RSM 09.21.16.33 10
L2 Paint & Trim	2800	SF	0.012	33.6	8	4.2	RSM 09.91.23.52 39
L2 Doors & Openings	14	EA	1.143	16.002	16	1.000125	RSM 08.11.63.23 04
L1							
L1 Exterior Partitions	1200	SF	0.046	55.2	16	3.45	RSM 09.21.16.33 10
L1 Storefront	3600	SF	0.171	615.6	56	10.99286	RSM 08.41.19.10 00
L1 Floors	19219	SF	0.025	480.475	40	12.01188	RSM 09.65.33.10 18
L1 Interior Partitions	2800	SF	0.046	128.8	16	5	RSM 09.21.16.33 10
L1 Ceiling Grid	38.438	500 SF	8	307.504	40	7.6876	Story Acoustics
L1 Ceiling Tile	24.02375	800 SF	8	192.19	40	4.80475	Story Acoustics
L1 Drywall	2800	SF	8	22400	above	4	RSM 09.21.16.33 10
L1 Paint & Trim	2800	SF	0.012	33.6	8	4.2	RSM 09.91.23.52 39
L1 Doors & Openings	30	EA	1.143	34.29	16	2.143125	RSM 08.11.63.23 04
L3							
L3 Curtain Wall	5859	SF	0.178	1042.902	56	18.62325	RSM 08.44.13.10 07
L3 Floors	19219	SF	0.03	576.57	32	18.01781	RSM 09.69.13.10 07
L3 Interior Partitions	2800	SF	0.046	128.8	16	5	RSM 09.21.16.33 10
L3 Ceiling Grid	38.438	500 SF	8	307.504	40	7.6876	Story Acoustics
L3 Ceiling Tile	24.02375	800 SF	8	192.19	40	4.80475	Story Acoustics
L3 Drywall	2800	SF	8	22400	above	4	RSM 09.21.16.33 10
L3 Paint & Trim	2800	SF	0.012	33.6	8	4.2	RSM 09.91.23.52 39
L3 Doors & Openings	14	EA	1.143	16.002	16	1.000125	RSM 08.11.63.23 04
L4							
L4 Curtain Wall	5859	SF	0.178	1042.902	56	18.62325	RSM 08.44.13.10 07
L4 Floors	19219	SF	0.03	576.57	32	18.01781	RSM 09.69.13.10 07
L4 Interior Partitions	2800	SF	0.046	128.8	16	5	RSM 09.21.16.33 10
L4 Ceiling Grid	38.438	500 SF	8	307.504	40	7.6876	Story Acoustics
L4 Ceiling Tile	24.02375	800 SF	8	192.19	40	4.80475	Story Acoustics
L4 Drywall	2800	SF	8	22400	above	4	RSM 09.21.16.33 10
L4 Paint & Trim	2800	SF	0.012	33.6	8	4.2	RSM 09.91.23.52 39
L4 Doors & Openings	14	EA	1.143	16.002	16	1.000125	RSM 08.11.63.23 04
L5							
L5 Deck Parapets	510	SF	0.046	23.46	16	1.46625	RSM 09.21.16.33 10
L5 Exterior Decking & WP	12.06	SQ	1.143	13.78458	32	0.430768	RSM 07.54.23.10 07
L5 Curtain Wall	5859	SF	0.178	1042.902	56	18.62325	RSM 08.44.13.10 07
L5 Floors	19219	SF	0.03	576.57	32	18.01781	RSM 09.69.13.10 07
L5 Interior Partitions	2800	SF	0.046	128.8	16	5	RSM 09.21.16.33 10
L5 Ceiling Grid	38.438	500 SF	8	307.504	40	7.6876	Story Acoustics
L5 Ceiling Tile	24.02375	800 SF	8	192.19	40	4.80475	Story Acoustics

SCHEDULE: PRODUCTIVITY ANALYSIS

Productivity rates for tasks

L5 Drywall	2800	SF	8	22400	above	4	RSM 09.21.16.33 10
L5 Paint & Trim	2800	SF	0.012	33.6	8	4.2	RSM 09.91.23.52 35
L5 Doors & Openings	14	EA	1.143	16.002	16	1.000125	RSM 08.11.63.23 04
L6							
L6 Curtain Wall	5600	SF	0.178	996.8	56	17.8	RSM 08.44.13.10 01
L6 Floors	18036	SF	0.03	541.08	32	16.90875	RSM 09.69.13.10 01
L6 Interior Partitions	2800	SF	0.046	128.8	16	5	RSM 09.21.16.33 10
L6 Ceiling Grid	36.072	500 SF	8	288.576	40	7.2144	Story Acoustics
L6 Ceiling Tile	22.545	800 SF	8	180.36	40	4.509	Story Acoustics
L6 Drywall	2800	SF	8	22400	above	4	RSM 09.21.16.33 10
L6 Paint & Trim	2800	SF	0.012	33.6	8	4.2	RSM 09.91.23.52 35
L6 Doors & Openings	14	EA	1.143	16.002	16	1.000125	RSM 08.11.63.23 04
L7							
L7 Curtain Wall	5600	SF	0.178	996.8	56	17.8	RSM 08.44.13.10 01
L7 Floors	18036	SF	0.03	541.08	32	16.90875	RSM 09.69.13.10 01
L7 Interior Partitions	2800	SF	0.046	128.8	16	5	RSM 09.21.16.33 10
L7 Ceiling Grid	36.072	500 SF	8	288.576	40	7.2144	Story Acoustics
L7 Ceiling Tile	22.545	800 SF	8	180.36	40	4.509	Story Acoustics
L7 Drywall	2800	SF	8	22400	above	4	RSM 09.21.16.33 10
L7 Paint & Trim	2800	SF	0.012	33.6	8	4.2	RSM 09.91.23.52 35
L7 Doors & Openings	14	EA	1.143	16.002	16	1.000125	RSM 08.11.63.23 04
Roof							
Roof parapets	400	SF	0.046	18.4	16	1.15	RSM 09.21.16.33 10
Roof WP, Insulation & Memberane	180.36	SQ	1.143	206.1515	32	6.442234	RSM 07.54.23.10 01
Take Down Tower crane	1	Days	8	8	8	1	ROM
Site Improvements							
Concrete at sidewalks	2800	SF	0.047	131.6	24	5.483333	RSM 32.06.10.10 04
Site concrete stem walls	40	CY	4.999	199.96	200	0.9998	RSM 03.30.53.40 42
Exterior "columns" & Cover	30	EA	0.75	22.5	8	2.8125	ROM
Exterior wood siding	3600	SF	0.05	180	40	4.5	ROM
Site Soil infill	1	Day	8	8	8	1	ROM
L5 deck plantings	1	Day	8	8	8	1	ROM
Site plants	4	Day	8	32	8	4	ROM
Exterior benches	3	Day	8	24	8	3	ROM
ROW Improvements							
Demo existing asphalt	5600	SF	0.03	168	48	3.5	RSM 02.41.13.17 57
Demo existing sidewalks	5600	SF	0.03	168	48	3.5	RSM 02.41.13.17 57
Prep asphalt base	1	Days	8	8	8	1	ROM
New concrete	5600	SF	0.047	263.2	24	10.96667	RSM 32.06.10.10 04
New asphalt	5600	SF	0.005	28	48	0.583333	RSM 32.12.16.14 00
Trash Receptacles	1	Day	8	8	8	1	ROM
Bike Racks	1	Day	8	8	8	1	ROM
Soil	3	Day	8	24	8	3	ROM
Plantings	3	Day	8	24	8	3	ROM
Street Painting	2	Day	8	16	8	2	ROM
Close-out							
TCO	1	Day	8	8	8	1	ROM
Punchlist	10	Day	8	80	8	10	ROM
CO	1	Day	8	8	8	1	ROM
				TOTALS	8247	1440.978	

SCHEDULE: PRODUCTIVITY ANALYSIS

Productivity rates for tasks

Item	QTY	Unit	MH/QTY	Total MH	MH/Crew	#Days	Ref
Wood & Concrete							
NTP	1	Day	8	8	8	1	General
Demo	259200	CF	0.003	777.6	48	16.2	RSM 02.41.16.15 0100
Abatement	4000	BCY	0.04	160	12	13.33333	RSM 02.56.13 0200
Substructure							
Site Prep							
Mass Ex	16000	BCY	0.02	320	16	20	RSM 31.23.16.42 0200
Shoring System	12000	SF	0.067	804	64	12.5625	RSM 31.41.15.10 1500
Structural Ex	1437	BCY	0.148	212.676	16	13.29225	RSM 31.23.16.42 6040
utilities ex	1200	LF	0.018	21.6	8	2.7	RSM 31.23.16.14 0600
final grading	2400	SY	0.015	36	16	2.25	RSM31.22.16.10 1100
utilitties r-in	21600	SF	0.003	64.8	16	4.05	ROM
P2							
P2 Footings (form, place, cure)	1315	CY	1.493	1963.295	112	17.52942	RSM 03.30.53.40 3850
underslab waterproofing	21600	SF	0.019	410.4	56	7.328571	RSM 07.12.13.20 0012
P2 Shear Core (form, place cure)	105.4	CY	7.377	777.5358	200	3.887679	RSM 03.30.53.40 4250
P2 Columns (form, place, cure)	111.1111	CY	15.911	1767.889	200	8.839444	RSM 03.30.53.40 0820
P2 Walls (form, place, cure)	406.5	CY	4.999	2032.094	200	10.16047	RSM 03.30.53.40 4270
underslab drainage	264	CY	0.111	29.304	8	3.663	RSM 03.05.13.25 1050
P2 SOG (form, place, cure)	21600	SF	0.021	453.6	56	8.1	RSM 03.30.53.40 3150
P2 MEP R-in	3	Days	8	24	8	3	ROM
P2 ramp (form, place, cure)	153.8519	CY	4.079	627.5617	208	3.017124	RSM 03.30.53.40 1950
P2 ramp post tensioning	1	Day	8	8	8	1	ROM
P1							
P1 deck (form, place, cure)	800	CY	4.079	3263.2	208	15.68846	RSM 03.30.53.40 1950
P1 MEP R-in	3	Days	8	24	8	3	ROM
P1 deck post tensioning	1	Days	8	8	1	8	ROM
P1 column (form, place, cure)	111.1111	CY	15.911	1767.889	200	8.839444	RSM 03.30.53.40 0820
P1 Walls (form, place, cure)	406.5	CY	4.999	2032.094	200	10.16047	RSM 03.30.53.40 4270
P1 Shear Core (form, place, cure)	105.4	CY	7.377	777.5358	200	3.887679	RSM 03.30.53.40 4250
P1 ramp (form, place, cure)	50.57074	CY	4.079	206.2781	208	0.991721	RSM 03.30.53.40 1950
P1 ramp post tensioning	1	Days	8	8	1	8	ROM
L1							
L1 decks (form, place, cure)	800	CY	4.079	3263.2	208	15.68846	RSM 03.30.53.40 1950
L1 Place embeds	5	Days	8	40	8	5	ROM
L1 MEP R-in	3	Days	8	24	8	3	ROM
L1 decks post tensioning	1	Days	8	8	1	8	ROM
L1 Shear Core (form, place, cure)	105.4	CY	7.377	777.5358	200	3.887679	RSM 03.30.53.40 4250
Superstructure							
Set up towercrane	3	Days	8	24	8	3	ROM
L2							
L2 Glulam Columns	20	EA	1.538	30.76	40	0.769	RSM 06.18.13.20 8304
L2 Shear Core (form, place, cure)	105.4	CY	7.377	777.5358	200	3.887679	RSM 03.30.53.40 4250
L2 Glulam Girders	24	EA	1.538	36.912	40	0.9228	RSM 06.18.13.20 8304
L2 CLT Flooring Panels	54	EA	0.5	27	8	3.375	Craig Leckness (Sup. RAF
L2 MEP R-in	3	Days	8	24	8	3	ROM
L3							
L3 Shear Core (form, place, cure)	105.4	CY	7.377	777.5358	200	3.887679	RSM 03.30.53.40 4250
L3 Glulam Girders	24	EA	1.538	36.912	40	0.9228	RSM 06.18.13.20 8304
L3 CLT Flooring Panels	54	EA	0.5	27	8	3.375	Craig Leckness (Sup. RAF
L3 MEP R-in	3	Days	8	24	8	3	ROM

SCHEDULE: PRODUCTIVITY ANALYSIS

Productivity rates for tasks

L4							
L4 Shear Core (form, place, cure)	105.4	CY	7.377	777.5358	200	3.887679	RSM 03.30.53.40 4250
L4 Glulam Columns	20	EA	1.538	30.76	40	0.769	RSM 06.18.13.20 8304
L4 Glulam Girders	24	EA	1.538	36.912	40	0.9228	RSM 06.18.13.20 8304
L4 CLT Flooring Panels	54	EA	0.5	27	8	3.375	Craig Leckness (Sup. RAFN)
L4 MEP R-in	3	Days	8	24	8	3	ROM
L5							
L5 Shear Core (form, place, cure)	105.4	CY	7.377	777.5358	200	3.887679	RSM 03.30.53.40 4250
L5 Glulam Girders	24	EA	1.538	36.912	40	0.9228	RSM 06.18.13.20 8304
L5 CLT Flooring Panels	54	EA	0.5	27	8	3.375	Craig Leckness (Sup. RAFN)
L5 MEP R-in	3	Days	8	24	8	3	ROM
L6							
L6 Shear Core (form, place, cure)	105.4	CY	7.377	777.5358	200	3.887679	RSM 03.30.53.40 4250
L6 Glulam Columns	20	EA	1.538	30.76	40	0.769	RSM 06.18.13.20 8304
L6 Glulam Girders	24	EA	1.538	36.912	40	0.9228	RSM 06.18.13.20 8304
L6 CLT Flooring Panels	46	EA	0.5	23	8	2.875	Craig Leckness (Sup. RAFN)
L6 MEP R-in	3	Days	8	24	8	3	ROM
L7							
L7 Shear Core (form, place, cure)	105.4	CY	7.377	777.5358	200	3.887679	RSM 03.30.53.40 4250
L7 Glulam Girders	24	EA	1.538	36.912	40	0.9228	RSM 06.18.13.20 8304
L7 CLT Flooring Panels	46	EA	0.5	23	8	2.875	Craig Leckness (Sup. RAFN)
L7 MEP R-in	3	Days	8	24	8	3	ROM
Roof							
Roof Shear Core (form, place, cure)	105.4	CY	7.377	777.5358	200	3.887679	RSM 03.30.53.40 4250
Roof Glulam Columns	20	EA	1.538	30.76	40	0.769	RSM 06.18.13.20 8304
Roof Glulam Girders	24	EA	1.538	36.912	40	0.9228	RSM 06.18.13.20 8304
Roof CLT Flooring Panels	46	EA	1.538	70.748	8	8.8435	Craig Leckness (Sup. RAFN)
Roof MEP R-in	3	Days	8	24	8	3	ROM
Top of Elevator							
TOE Shear Core (form, place, cure)	105.4	CY	7.377	777.5358	200	3.887679	RSM 03.30.53.40 4250
TOE CLT Panels	7	EA	0.5	3.5	8	0.4375	Craig Leckness (Sup. RAFN)
TOE MEP R-in	3	Days	8	24	8	3	ROM
MEP Systems							
P2							
P2 Plumbing	10	Days	8	80	8	10	ROM
P2 Sprinklers	10	Days	8	80	8	10	ROM
P2 HVAC	10	Days	8	80	8	10	ROM
P2 Mech room equip	5	Days	8	40	8	5	ROM
P2 Electrical	10	Days	8	80	8	10	ROM
P2 Elevator hoistways	5	Days	8	40	8	5	ROM
P2 Elevators	5	Days	8	40	8	5	ROM
P2 Elevator Room	5	Days	8	40	8	5	ROM
P1							
P1 Plumbing	10	Days	8	80	8	10	ROM
P1 Sprinklers	10	Days	8	80	8	10	ROM
P1 HVAC	10	Days	8	80	8	10	ROM
P1 Electrical	10	Days	8	80	8	10	ROM

SCHEDULE: PRODUCTIVITY ANALYSIS

Productivity rates for tasks

L1							
L1 Plumbing	10	Days	8	80	8	10	ROM
L1 Sprinklers	10	Days	8	80	8	10	ROM
L1 HVAC	10	Days	8	80	8	10	ROM
L1 Electrical	10	Days	8	80	8	10	ROM
L2							
L2 Plumbing	10	Days	8	80	8	10	ROM
L2 Sprinklers	10	Days	8	80	8	10	ROM
L2 HVAC	10	Days	8	80	8	10	ROM
L2 Electrical	10	Days	8	80	8	10	ROM
L3							
L3 Plumbing	10	Days	8	80	8	10	ROM
L3 Sprinklers	10	Days	8	80	8	10	ROM
L3 HVAC	10	Days	8	80	8	10	ROM
L3 Electrical	10	Days	8	80	8	10	ROM
L4							
L4 Plumbing	10	Days	8	80	8	10	ROM
L4 Sprinklers	10	Days	8	80	8	10	ROM
L4 HVAC	10	Days	8	80	8	10	ROM
L4 Electrical	10	Days	8	80	8	10	ROM
L5							
L5 Plumbing	10	Days	8	80	8	10	ROM
L5 Sprinklers	10	Days	8	80	8	10	ROM
L5 HVAC	10	Days	8	80	8	10	ROM
L5 Electrical	10	Days	8	80	8	10	ROM
L6							
L6 Plumbing	10	Days	8	80	8	10	ROM
L6 Sprinklers	10	Days	8	80	8	10	ROM
L6 HVAC	10	Days	8	80	8	10	ROM
L6 Electrical	10	Days	8	80	8	10	ROM
L7							
L7 Plumbing	10	Days	8	80	8	10	ROM
L7 Sprinklers	10	Days	8	80	8	10	ROM
L7 HVAC	10	Days	8	80	8	10	ROM
L7 Electrical	10	Days	8	80	8	10	ROM
Roof							
Roof Plumbing	10	Days	8	80	8	10	ROM
Roof Sprinklers	10	Days	8	80	8	10	ROM
Roof HVAC	10	Days	8	80	8	10	ROM
Roof Electrical	10	Days	8	80	8	10	ROM
Rooftop equipment, lighting, etc	5	Days	8	40	8	5	ROM
Commissioning Electrical	5	Days	8	40	8	5	ROM
Commissioning Plumbing	5	Days	8	40	8	5	ROM
Commissioning Sprinklers	5	Days	8	40	8	5	ROM
Commissioning HVAC	5	Days	8	40	8	5	ROM
Finishes							
P2							
P2 El Lobby Storefront	360	SF	0.171	61.56	16	3.8475	RSM 08.41.19.10 0050
P2 El Lobby Floors	525	SF	0.025	13.125	8	1.640625	RSM 09.65.33.10 1800
P2 Ceiling Grid	1.05	500 SF	8	8.4	8	1.05	Story Acoustics
P2 Parking Paint	2400	LF	0.003	7.2	40	0.18	RSM 32.17.23.13 0730
P2 Bollards & misc	5	EA	2.4	12	24	0.5	RSM 34.71.13.17 2700
P2 El Lobby Paint & Trim	600	SF	0.012	7.2	8	0.9	RSM 09.91.23.52 3940
P2 Ceiling Tile	0.65625	800 SF	8	5.25	8	0.65625	Story Acoustics
P1							
P1 Elevator Lobby Storefront	360	SF	0.171	61.56	16	3.8475	RSM 08.41.19.10 0050
P1 El Lobby Floors	525	SF	0.025	13.125	8	1.640625	RSM 09.65.33.10 1800

SCHEDULE: PRODUCTIVITY ANALYSIS

Productivity rates for tasks

P1 Ceiling Grid	1.05	500 SF	8	8.4	8	1.05	Story Acoustics
P1 Parking Paint	2400	LF	0.003	7.2	40	0.18	RSM 32.17.23.13 0730
P1 Bollards & misc	5	EA	2.4	12	24	0.5	RSM 34.71.13.17 2700
P1 El Lobby Paint & Trim	600	SF	0.012	7.2	8	0.9	RSM 09.91.23.52 3940
P1 Ceiling Tile	0.65625	800 SF	8	5.25	8	0.65625	Story Acoustics
L2							
L2 Curtain Wall	5859	SF	0.178	1042.902	56	18.62325	RSM 08.44.13.10 0150
L2 Floors	19219	SF	0.03	576.57	32	18.01781	RSM 09.69.13.10 0120
L2 Interior Partitions	2800	SF	0.046	128.8	16	5	RSM 09.21.16.33 1000
L2 Drywall	2800	SF	8	22400	above	4	RSM 09.21.16.33 1000
L2 Paint & Trim	2800	SF	0.012	33.6	8	4.2	RSM 09.91.23.52 3940
L2 Doors & Openings	14	EA	1.143	16.002	16	1.000125	RSM 08.11.63.23 0440
L1							
L1 Exterior Partitions	1200	SF	0.046	55.2	16	3.45	RSM 09.21.16.33 1000
L1 Storefront	3600	SF	0.171	615.6	56	10.99286	RSM 08.41.19.10 0050
L1 Floors	19219	SF	0.025	480.475	40	12.01188	RSM 09.65.33.10 1800
L1 Interior Partitions	2800	SF	0.046	128.8	16	5	RSM 09.21.16.33 1000
L1 Drywall	2800	SF	8	22400	above	4	RSM 09.21.16.33 1000
L1 Paint & Trim	2800	SF	0.012	33.6	8	4.2	RSM 09.91.23.52 3940
L1 Doors & Openings	30	EA	1.143	34.29	16	2.143125	RSM 08.11.63.23 0440
L3							
L3 Curtain Wall	5859	SF	0.178	1042.902	56	18.62325	RSM 08.44.13.10 0150
L3 Curtain Wall	19219	SF	0.03	576.57	32	18.01781	RSM 09.69.13.10 0120
L3 Interior Partitions	2800	SF	0.046	128.8	16	5	RSM 09.21.16.33 1000
L3 Drywall	2800	SF	8	22400	above	4	RSM 09.21.16.33 1000
L3 Paint & Trim	2800	SF	0.012	33.6	8	4.2	RSM 09.91.23.52 3940
L3 Doors & Openings	14	EA	1.143	16.002	16	1.000125	RSM 08.11.63.23 0440
L4							
L4 Curtain Wall	5859	SF	0.178	1042.902	56	18.62325	RSM 08.44.13.10 0150
L4 Floors	19219	SF	0.03	576.57	32	18.01781	RSM 09.69.13.10 0120
L4 Interior Partitions	2800	SF	0.046	128.8	16	5	RSM 09.21.16.33 1000
L4 Drywall	2800	SF	8	22400	above	4	RSM 09.21.16.33 1000
L4 Paint & Trim	2800	SF	0.012	33.6	8	4.2	RSM 09.91.23.52 3940
L4 Doors & Openings	14	EA	1.143	16.002	16	1.000125	RSM 08.11.63.23 0440
L5							
L5 Deck Parapets	510	SF	0.046	23.46	16	1.46625	RSM 09.21.16.33 1000
L5 Exterior Decking & WP	12.06	SQ	1.143	13.78458	32	0.430768	RSM 07.54.23.10 0160
L5 Curtain Wall	5859	SF	0.178	1042.902	56	18.62325	RSM 08.44.13.10 0150
L5 Floors	19219	SF	0.03	576.57	32	18.01781	RSM 09.69.13.10 0120
L5 Interior Partitions	2800	SF	0.046	128.8	16	5	RSM 09.21.16.33 1000
L5 Drywall	2800	SF	8	22400	above	4	RSM 09.21.16.33 1000
L5 Paint & Trim	2800	SF	0.012	33.6	8	4.2	RSM 09.91.23.52 3940
L5 Doors & Openings	14	EA	1.143	16.002	16	1.000125	RSM 08.11.63.23 0440
L6							
L6 Curtain Wall	5600	SF	0.178	996.8	56	17.8	RSM 08.44.13.10 0150
L6 Floors	18036	SF	0.03	541.08	32	16.90875	RSM 09.69.13.10 0120
L6 Interior Partitions	2800	SF	0.046	128.8	16	5	RSM 09.21.16.33 1000
L6 Drywall	2800	SF	8	22400	above	4	RSM 09.21.16.33 1000
L6 Paint & Trim	2800	SF	0.012	33.6	8	4.2	RSM 09.91.23.52 3940
L6 Doors & Openings	14	EA	1.143	16.002	16	1.000125	RSM 08.11.63.23 0440
L7							
L7 Curtain Wall	5600	SF	0.178	996.8	56	17.8	RSM 08.44.13.10 0150
L7 Floors	18036	SF	0.03	541.08	32	16.90875	RSM 09.69.13.10 0120
L7 Interior Partitions	2800	SF	0.046	128.8	16	5	RSM 09.21.16.33 1000
L7 Drywall	2800	SF	8	22400	above	4	RSM 09.21.16.33 1000
L7 Paint & Trim	2800	SF	0.012	33.6	8	4.2	RSM 09.91.23.52 3940
L7 Doors & Openings	14	EA	1.143	16.002	16	1.000125	RSM 08.11.63.23 0440
Roof							
Roof parapets	400	SF	0.046	18.4	16	1.15	RSM 09.21.16.33 1000

SCHEDULE: CREDITS

Research Guides

RS Means

RSMeans Mechanical Cost Data 2015 / RS Means. Norwell, MA: RSMeans, 2014. Print.

Gregg George

Superintendent, RAFN
206-510-3836
ggeorge@rafn.com

Tim O'Neil

Project Executive, Skanska
206-459-7784
Tim.ONeill@skanska.com

Lisa Picard

Executive Vice President, Skanska
206-356-5134
lisa.picard@skanska.com

Peter Losh

Project Manager, PCL
425-577-4213
pmlosh@cpl.com

Bruce Macaulay

Superintendent, PCL
206-437-0299
bmacaulay@pcl.com

CHAPTER SEVEN

Environmental Analysis

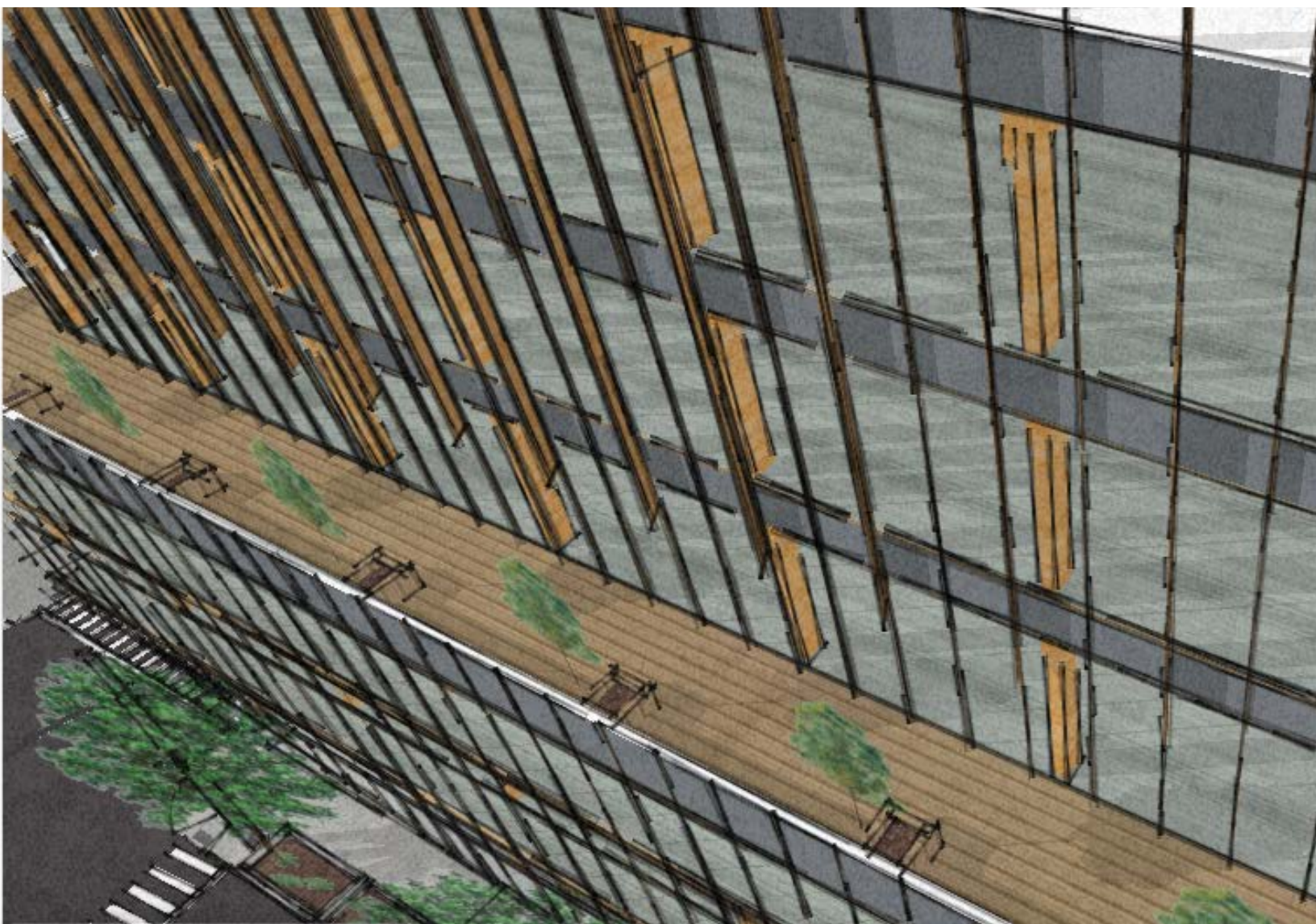

Schedule Guidelines/Assumptions:

- A full building LCA was done using Athena Impact Estimator 5.1 for the baseline comparison. An alternate study was done comparing the baseline steel model to the covered wood option explored in Chapter 5
- To calculate quantity of rebar in the building, drawings from a building of a similar were used to determine lbs of rebar per CY of type of assembly. These quantities were used to calculate total tons of rebar for both options.
- Where exact material descriptions used for this project were not found in the Athena database, the next closest materials were used
- Material assumptions made have been held constant across all project LCA studies

ENVIRONMENT: ANALYSIS SUMMARY

Baseline Comparison

GOALS:

The goals of this LCA study are as follows:

1. Obtain LCA results on the greenhouse gas emissions of the building described in Chapters 1-6 if that building were to be created with the baseline wood assembly system.
2. Obtain LCA study on the greenhouse gas emissions of the building described in Chapters 1-6 if that building were to be created with the baseline steel assembly system.
3. Obtain LCA study on the greenhouse gas emissions of the building described in Chapters 1-6 if that building were to be created with the covered wood assembly system, which represents the worst case scenario for wood. As the worst case scenario option, comparing this item to the baseline steel will show how wood performs should the code require for wood to be covered.
4. Compare and analyze the results of the LCA on greenhouse gas emissions for the three options. NOTE: This is a screening level LCA used to gain a general sense of the magnitude of environmental impact between different systems but not comprehensive enough to declare the absolute differences between different construction methods.

SCOPE:

All three options will be compared from material quantities derived from the Revit model. The analysis includes the following building components:

- Foundation systems (all concrete for footings, walls, slabs and columns, topping slabs)
- Superstructure (all beams, girders, columns, connections)
- Fire coverings (assumed to be GWB)
- Paint
- Dropped Ceilings
- Exterior Curtain Wall
- Exterior walls at Level 1 (metal stud walls)

ANALYSIS CATEGORIES:

The analysis category that will be evaluated for the purposes of this research assignment will be the global warming potential category only, measured in kg CO₂ eq. While other impact categories deserve further exploration, this particular research thesis is interested on the effects of wood on global warming and any potential benefits that would provide in this respect. The analysis will be held for the entire building life cycle, from the Product category (A) to Beyond the End of Life category (D).

METHODOLOGY:

Given the limitations of the analysis, assumptions had to be made for certain finish items. Where assumptions have been made, they have been maintained for all three comparison categories to get more accurate results. All exterior walls and curtain wall items were developed using Athena's "Assembly" section for walls. For all other building components as listed above, the "Extra Basic Materials" category was used to input the data.

The results of the data are as shown in the following pages of this chapter:

ENVIRONMENT: ANALYSIS SUMMARY

Global Warming Total Impacts

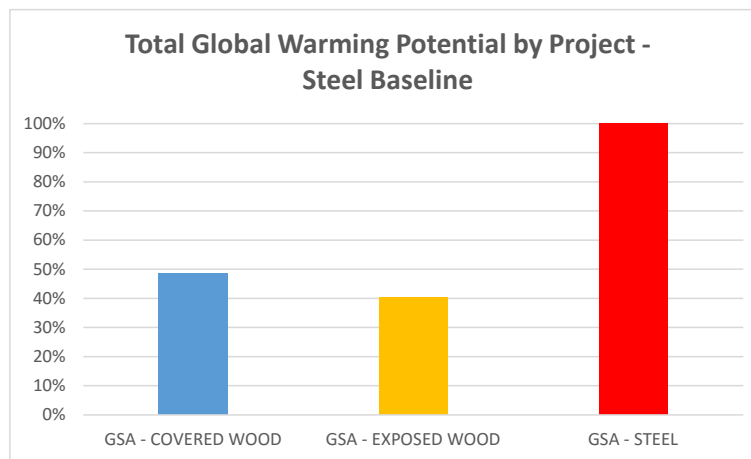
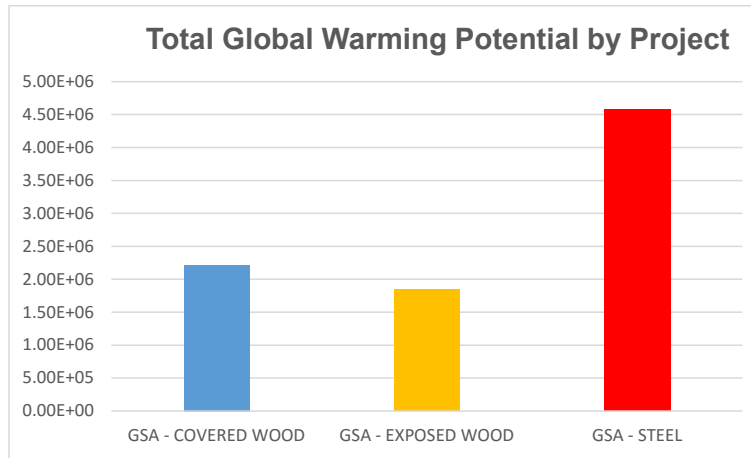

Project Name	Unit	Foundations	Walls	Columns and Beams	Floors	Roofs	Extra Materials	Total	Percent of Total
GSA - COVERED WOOD	kg CO2 eq	0.00E+00	8.86E+05	0.00E+00	0.00E+00	0.00E+00	1.33E+06	2.22E+06	48%
GSA - EXPOSED WOOD	kg CO2 eq	0.00E+00	8.86E+05	0.00E+00	0.00E+00	0.00E+00	9.56E+05	1.84E+06	40%
GSA - STEEL	kg CO2 eq	0.00E+00	8.86E+05	0.00E+00	0.00E+00	0.00E+00	3.69E+06	4.57E+06	100%
Total	kg CO2 eq	0.00E+00	2.66E+06	0.00E+00	0.00E+00	0.00E+00	5.98E+06	8.63E+06	

The graphs above represent the total combined performance of all three categories for global warming potential. The upper graph represents the performance of the options as measured by kg of CO2 produced. The graph below represents the performance of the two wood options with the Steel option held as the baseline (100%) for comparison. Athena's results indicate that the wood performs significantly better than steel when looking at greenhouse gas emissions. At its most optimized, a wood building of the same size would perform 60% better than its steel counterpart. At its worst comparison option, wood performs approximately 50-52% better. However, it should be noted that this is a cursory LCA analysis, and more study and design development should be implemented to provide a more accurate analysis. For instance, none of the project types above are including operational energy.

Some other limitations of these results are that there are material category items that are not present as options in the Athena program, so assumptions were made. Also, as the "Extra Basic Materials" category was used instead of Athena's "Assembly" categories for the structure, it is unclear as to how switching from a simple quantity input in the "Extra Basic Materials" category to a more structured input in the "Assembly" category would impact these results.

ENVIRONMENT: ANALYSIS SUMMARY

Global Warming Impacts by Life Cycle

Comparison of Global Warming Potential By Life Cycle Stage

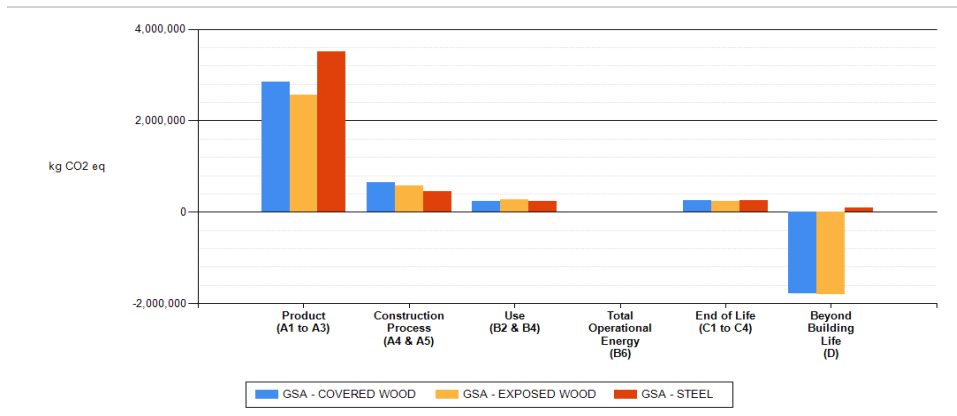

Project Name	Unit	Product (A1 to A3)	Construction Process (A4 & A5)	Use (B2 & B4)	Total Operational Energy (B6)	End of Life (C1 to C4)	Beyond Building Life (D)	Total
GSA - COVERED WOOD	kg CO2 eq	2.85E+06	6.40E+05	2.46E+05	0.00E+00	2.59E+05	-1.78E+06	2.22E+06
GSA - EXPOSED WOOD	kg CO2 eq	2.56E+06	5.85E+05	2.66E+05	0.00E+00	2.39E+05	-1.80E+06	1.84E+06
GSA - STEEL	kg CO2 eq	3.52E+06	4.49E+05	2.46E+05	0.00E+00	2.61E+05	1.02E+05	4.57E+06
Total	kg CO2 eq	8.92E+06	1.67E+06	7.58E+05	0.00E+00	7.59E+05	-3.48E+06	8.63E+06

Comparison of Global Warming Potential By Life Cycle Stage [With GSA - STEEL as Project Baseline]

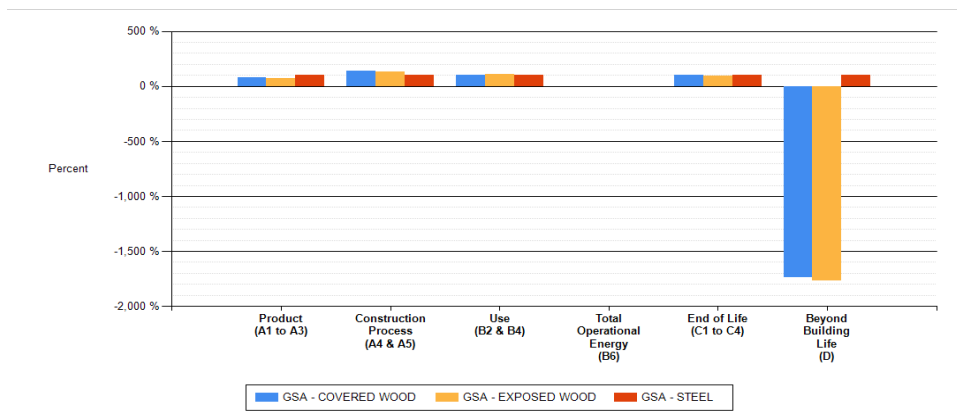

Project Name	Unit	Product (A1 to A3)	Construction Process (A4 & A5)	Use (B2 & B4)	Total Operational Energy (B6)	End of Life (C1 to C4)	Beyond Building Life (D)
GSA - COVERED WOOD	kg CO2 eq	81%	143%	100%	0%	99%	-1,742%
GSA - EXPOSED WOOD	kg CO2 eq	73%	130%	108%	0%	92%	-1,767%
GSA - STEEL	kg CO2 eq	100%	100%	100%	0%	100%	100%

The graphs shown here depict the impact of greenhouse gas emissions per each life cycle stage, from the product category (A) to beyond the building’s life cycle (D). Based on the results of this analysis, it appears that wood performs on par or even slightly worse than steel in categories A to C. Operational energy has not been included in this analysis as only the material products and their inherent embodied energy is being analyzed. Only when taking into account Category “D” which shows the wood beyond the building life cycle does wood present a significant advantage. Athena’s interpretation of wood as a renewable resource responsible for carbon sequestration can be considered one reason for the large negative impact produced by wood at category D.

The Athena LCA analysis demonstrates that the wood structure results in a significant reduction of greenhouse gas emissions when compared to the steel structure both due to the reduced emissions during manufacturing and the carbon sequestered during the growth of the trees.

ENVIRONMENT: LCA RESULTS

Athena Computation Results

BASELINE

Summary Measure	Unit	PRODUCT (A1 to A3)			CONSTRUCTION PROCESS (A4 & A5)			USE (B2, B4 & B6)				END OF LIFE (C1 to C4)			BEYOND BUILDING LIFE (D)			TOTAL EFFECTS	
		Manufacturing	Transport	Total	Construction-Installation Process	Transport	Total	Replacement Manufacturing	Replacement Transport	Operational Energy Use Total	Total	Deconstruction, Demolition, Disposal & Waste Processing	Transport	Total	BBL Material	BBL Transport	Total	A to C	A to D
Global Warming Potential	kg CO2 eq	3.39E+06	6.96E+04	3.46E+06	2.01E+05	2.38E+05	4.39E+05	2.38E+05	8.11E+03	0.00E+00	2.46E+05	2.06E+05	5.18E+04	2.57E+05	9.85E+04	0.00E+00	9.85E+04	4.40E+06	4.50E+06
Acidification Potential	kg SO2 eq	1.56E+04	6.40E+02	1.62E+04	1.78E+03	2.37E+03	4.15E+03	1.44E+03	8.30E+01	0.00E+00	1.52E+03	1.93E+03	4.67E+02	2.40E+03	1.55E+02	0.00E+00	1.55E+02	2.43E+04	2.44E+04
HH Particulate	kg PM2.5 eq	1.12E+04	3.76E+01	1.13E+04	1.80E+02	1.33E+02	3.13E+02	3.72E+03	4.58E+00	0.00E+00	3.72E+03	1.94E+02	2.80E+01	2.22E+02	1.18E+02	0.00E+00	1.18E+02	1.55E+04	1.56E+04
Eutrophication Potential	kg N eq	8.97E+02	4.37E+01	9.41E+02	1.24E+02	1.61E+02	2.85E+02	6.54E+01	5.62E+00	0.00E+00	7.11E+01	1.05E+02	3.19E+01	1.37E+02	1.20E+01	0.00E+00	1.20E+01	1.43E+03	1.45E+03
Ozone Depletion Potential	kg CFC-11 eq	2.48E-02	2.51E-06	2.48E-02	1.24E-03	9.29E-06	1.25E-03	2.02E-04	3.24E-07	0.00E+00	2.03E-04	1.06E-05	1.86E-06	1.25E-05	-3.00E-06	0.00E+00	-3.00E-06	2.63E-02	2.63E-02
Smog Potential	kg O3 eq	1.65E+05	2.23E+04	1.87E+05	5.05E+04	8.23E+04	1.32E+05	2.59E+04	2.89E+03	0.00E+00	2.88E+04	5.47E+04	1.62E+04	7.09E+04	1.67E+03	0.00E+00	1.67E+03	4.20E+05	4.22E+05
Total Primary Energy	MJ	4.25E+07	9.00E+05	4.34E+07	2.59E+06	3.11E+06	5.71E+06	2.01E+06	1.10E+05	0.00E+00	2.12E+06	2.98E+06	6.32E+05	3.62E+06	1.95E+05	0.00E+00	1.95E+05	5.49E+07	5.51E+07
Non-Renewable Energy	MJ	4.24E+07	9.00E+05	4.33E+07	2.59E+06	3.11E+06	5.70E+06	1.98E+06	1.10E+05	0.00E+00	2.09E+06	2.97E+06	6.31E+05	3.60E+06	1.99E+05	0.00E+00	1.99E+05	5.47E+07	5.49E+07
Fossil Fuel Consumption	MJ	3.06E+07	8.98E+05	3.15E+07	2.36E+06	3.11E+06	5.47E+06	1.74E+06	1.10E+05	0.00E+00	1.85E+06	2.84E+06	6.30E+05	3.47E+06	8.15E+05	0.00E+00	8.15E+05	4.22E+07	4.31E+07

Summary Measure	Unit	PRODUCT (A1 to A3)			CONSTRUCTION PROCESS (A4 & A5)			USE (B2, B4 & B6)				END OF LIFE (C1 to C4)			BEYOND BUILDING LIFE (D)			TOTAL EFFECTS	
		Manufacturing	Transport	Total	Construction-Installation Process	Transport	Total	Replacement Manufacturing	Replacement Transport	Operational Energy Use Total	Total	Deconstruction, Demolition, Disposal & Waste Processing	Transport	Total	BBL Material	BBL Transport	Total	A to C	A to D
Global Warming Potential	kg CO2 eq	2.49E+06	6.79E+04	2.56E+06	1.61E+05	4.24E+05	5.85E+05	2.57E+05	8.98E+03	0.00E+00	2.66E+05	1.88E+05	5.16E+04	2.39E+05	-1.80E+06	0.00E+00	-1.80E+06	3.65E+06	1.84E+06
Acidification Potential	kg SO2 eq	1.24E+04	6.24E+02	1.30E+04	1.48E+03	4.32E+03	5.80E+03	1.55E+03	9.15E+01	0.00E+00	1.64E+03	1.93E+03	4.66E+02	2.39E+03	3.09E+02	0.00E+00	3.09E+02	2.28E+04	2.31E+04
HH Particulate	kg PM2.5 eq	8.76E+03	3.67E+01	8.79E+03	1.32E+02	2.40E+02	3.72E+02	4.21E+03	5.06E+00	0.00E+00	4.22E+03	1.03E+02	2.79E+01	1.31E+02	1.86E+02	0.00E+00	1.86E+02	1.35E+04	1.37E+04
Eutrophication Potential	kg N eq	8.12E+02	4.26E+01	8.55E+02	1.05E+02	2.93E+02	3.98E+02	6.82E+01	6.20E+00	0.00E+00	7.44E+01	1.14E+02	3.18E+01	1.45E+02	1.99E+01	0.00E+00	1.99E+01	1.47E+03	1.49E+03
Ozone Depletion Potential	kg CFC-11 eq	3.41E-02	2.45E-06	3.41E-02	1.18E-03	1.69E-05	1.20E-03	2.49E-04	3.57E-07	0.00E+00	2.50E-04	1.07E-05	1.85E-06	1.26E-05	-3.00E-06	0.00E+00	-3.00E-06	3.56E-02	3.56E-02
Smog Potential	kg O3 eq	1.54E+05	2.17E+04	1.76E+05	4.47E+04	1.50E+05	1.95E+05	2.73E+04	3.19E+03	0.00E+00	3.04E+04	5.96E+04	1.62E+04	7.58E+04	3.66E+03	0.00E+00	3.66E+03	4.77E+05	4.81E+05
Total Primary Energy	MJ	3.68E+07	8.74E+05	3.77E+07	2.11E+06	5.65E+06	7.75E+06	2.79E+06	1.22E+05	0.00E+00	2.91E+06	2.69E+06	6.30E+05	3.32E+06	5.03E+05	0.00E+00	5.03E+05	5.17E+07	5.22E+07
Non-Renewable Energy	MJ	2.86E+07	8.74E+05	2.95E+07	2.02E+06	5.64E+06	7.67E+06	2.76E+06	1.21E+05	0.00E+00	2.89E+06	2.68E+06	6.30E+05	3.31E+06	5.07E+05	0.00E+00	5.07E+05	4.33E+07	4.38E+07
Fossil Fuel Consumption	MJ	2.14E+07	8.72E+05	2.23E+07	1.86E+06	5.63E+06	7.49E+06	2.51E+06	1.21E+05	0.00E+00	2.63E+06	2.62E+06	6.29E+05	3.25E+06	1.43E+06	0.00E+00	1.43E+06	3.57E+07	3.71E+07

Summary Measure	Unit	PRODUCT (A1 to A3)			CONSTRUCTION PROCESS (A4 & A5)			USE (B2, B4 & B6)				END OF LIFE (C1 to C4)			BEYOND BUILDING LIFE (D)			TOTAL EFFECTS	
		Manufacturing	Transport	Total	Construction-Installation Process	Transport	Total	Replacement Manufacturing	Replacement Transport	Operational Energy Use Total	Total	Deconstruction, Demolition, Disposal & Waste Processing	Transport	Total	BBL Material	BBL Transport	Total	A to C	A to D
Global Warming Potential	kg CO2 eq	2.77E+06	7.65E+04	2.85E+06	1.89E+05	4.51E+05	6.40E+05	2.38E+05	8.11E+03	0.00E+00	2.46E+05	1.99E+05	5.94E+04	2.59E+05	-1.78E+06	0.00E+00	-1.78E+06	4.00E+06	2.22E+06
Acidification Potential	kg SO2 eq	1.38E+04	7.03E+02	1.45E+04	1.74E+03	4.59E+03	6.32E+03	1.44E+03	8.30E+01	0.00E+00	1.52E+03	2.07E+03	5.35E+02	2.60E+03	3.68E+02	0.00E+00	3.68E+02	2.50E+04	2.53E+04
HH Particulate	kg PM2.5 eq	9.20E+03	4.13E+01	9.24E+03	1.54E+02	2.55E+02	4.08E+02	3.72E+03	4.58E+00	0.00E+00	3.72E+03	1.11E+02	3.21E+01	1.43E+02	2.11E+02	0.00E+00	2.11E+02	1.35E+04	1.37E+04
Eutrophication Potential	kg N eq	9.19E+02	4.80E+01	9.67E+02	1.23E+02	3.11E+02	4.33E+02	6.54E+01	5.62E+00	0.00E+00	7.11E+01	1.23E+02	3.66E+01	1.59E+02	2.29E+01	0.00E+00	2.29E+01	1.63E+03	1.65E+03
Ozone Depletion Potential	kg CFC-11 eq	3.69E-02	2.76E-06	3.69E-02	1.33E-03	1.80E-05	1.35E-03	2.02E-04	3.24E-07	0.00E+00	2.03E-04	1.12E-05	2.13E-06	1.33E-05	-3.00E-06	0.00E+00	-3.00E-06	3.85E-02	3.85E-02
Smog Potential	kg O3 eq	1.64E+05	2.44E+04	1.88E+05	5.08E+04	1.60E+05	2.10E+05	2.59E+04	2.89E+03	0.00E+00	2.88E+04	6.44E+04	1.86E+04	8.30E+04	4.25E+03	0.00E+00	4.25E+03	5.10E+05	5.15E+05
Total Primary Energy	MJ	4.03E+07	9.84E+05	4.13E+07	2.49E+06	5.99E+06	8.49E+06	2.01E+06	1.10E+05	0.00E+00	2.12E+06	2.86E+06	7.24E+05	3.59E+06	6.19E+05	0.00E+00	6.19E+05	5.55E+07	5.61E+07
Non-Renewable Energy	MJ	3.21E+07	9.84E+05	3.31E+07	2.41E+06	5.99E+06	8.40E+06	1.98E+06	1.10E+05	0.00E+00	2.09E+06	2.85E+06	7.24E+05	3.57E+06	6.23E+05	0.00E+00	6.23E+05	4.72E+07	4.78E+07
Fossil Fuel Consumption	MJ	2.43E+07	9.82E+05	2.52E+07	2.22E+06	5.98E+06	8.20E+06	1.74E+06	1.10E+05	0.00E+00	1.85E+06	2.79E+06	7.23E+05	3.51E+06	1.67E+06	0.00E+00	1.67E+06	3.88E+07	4.05E+07

ENVIRONMENT: MATERIAL QUANTITY INPUT

Steel & Wood Baseline - Bill of Materials

Bill of Materials Report

Project: GSA - STEEL

Material	Unit	Total Quantity	Columns & Beams	Floors	Foundations	Roofs	Walls	Extra Basic Materials	Mass Value	Mass Unit
3 mil Polyethylene	sf	1253.1584	0	0	0	0	1253.158	0	0.0096	Tons (short)
5/8" Fire-Rated Type X Gypsum Board	sf	351901	0	0	0	0	0	351901	378.7541	Tons (short)
5/8" Gypsum Fibre Gypsum Board	sf	1299.4666	0	0	0	0	1299.467	0	1.8631	Tons (short)
5/8" Regular Gypsum Board	sf	139650.5	0	0	0	0	0	139650.5	147.1607	Tons (short)
Air Barrier	sf	1253.1584	0	0	0	0	1253.158	0	0.0078	Tons (short)
Aluminum Extrusion	Tons (short)	52.5241	0	0	0	0	52.5241	0	52.5241	Tons (short)
Concrete Benchmark 3000 psi	yd3	6760.845	0	0	0	0	0	6760.845	13068.7252	Tons (short)
EPDM membrane (black, 60 mil)	lbs	4358.2726	0	0	0	0	4358.273	0	2.1791	Tons (short)
Expanded Polystyrene	sf (1")	70.0731	0	0	0	0	70.0731	0	0.0052	Tons (short)
FG Batt R11-15	sf (1")	174252.451	0	0	0	0	174252.5	0	5.5864	Tons (short)
FG Batt R20	sf (1")	6702.725	0	0	0	0	6702.725	0	0.1849	Tons (short)
Galvanized Decking	Tons (short)	145.44	0	0	0	0	0	145.44	145.44	Tons (short)
Galvanized Sheet	Tons (short)	0.1365	0	0	0	0	0.1365	0	0.1365	Tons (short)
Galvanized Studs	Tons (short)	0.3296	0	0	0	0	0.3296	0	0.3296	Tons (short)
Glazing Panel	Tons (short)	211.71	0	0	0	0	211.71	0	211.71	Tons (short)
Joint Compound	Tons (short)	0.1328	0	0	0	0	0.1328	0	0.1328	Tons (short)
Metal Wall Cladding - Commercial (26 Ga.)	sf	2863.5519	0	0	0	0	2863.552	0	1.4318	Tons (short)
Nails	Tons (short)	0.0389	0	0	0	0	0.0389	0	0.0389	Tons (short)
Paper Tape	Tons (short)	0.0015	0	0	0	0	0.0015	0	0.0015	Tons (short)
Rebar, Rod, Light Sections	Tons (short)	465.812	0	0	0	0	0	465.812	465.812	Tons (short)
Screws Nuts & Bolts	Tons (short)	1.8214	0	0	0	0	1.8214	0	1.8214	Tons (short)
Softwood Plywood	msf (3/8")	1.6497	0	0	0	0	1.6497	0	0.7981	Tons (short)
Solvent Based Alkyd Paint	Gallons (us)	0.1557	0	0	0	0	0.1557	0	0.0005	Tons (short)
Spandrel Panel	Tons (short)	14.0306	0	0	0	0	14.0306	0	14.0306	Tons (short)
Water Based Latex Paint	Gallons (us)	1551.1301	0	0	0	0	82.3301	1468.8	4.8543	Tons (short)
Wide Flange Sections	Tons (short)	641.956	0	0	0	0	0	641.956	641.956	Tons (short)

Bill of Materials Report

Project: GSA - EXPOSED WOOD

Material	Unit	Total Quantity	Columns & Beams	Floors	Foundations	Roofs	Walls	Extra Basic Materials	Mass Value	Mass Unit
3 mil Polyethylene	sf	1253.1584	0	0	0	0	1253.158	0	0.0096	Tons (short)
5/8" Gypsum Fibre Gypsum Board	sf	1299.4666	0	0	0	0	1299.467	0	1.8631	Tons (short)
Air Barrier	sf	1253.1584	0	0	0	0	1253.158	0	0.0078	Tons (short)
Aluminum Extrusion	Tons (short)	52.5241	0	0	0	0	52.5241	0	52.5241	Tons (short)
Concrete Benchmark 3000 psi	yd3	5832.9915	0	0	0	0	0	5832.9915	11275.1828	Tons (short)
Cross Laminated Timber	ft3	89652.953	0	0	0	0	0	89652.953	1330.5109	Tons (short)
EPDM membrane (black, 60 mil)	lbs	4358.2726	0	0	0	0	4358.273	0	2.1791	Tons (short)
Expanded Polystyrene	sf (1")	70.0731	0	0	0	0	70.0731	0	0.0052	Tons (short)
FG Batt R11-15	sf (1")	174252.451	0	0	0	0	174252.5	0	5.5864	Tons (short)
FG Batt R20	sf (1")	6702.725	0	0	0	0	6702.725	0	0.1849	Tons (short)
Galvanized Sheet	Tons (short)	0.1365	0	0	0	0	0.1365	0	0.1365	Tons (short)
Galvanized Studs	Tons (short)	0.3296	0	0	0	0	0.3296	0	0.3296	Tons (short)
Glazing Panel	Tons (short)	211.71	0	0	0	0	211.71	0	211.71	Tons (short)
Glulam Sections	ft3	11466.025	0	0	0	0	0	11466.025	142.1898	Tons (short)
Joint Compound	Tons (short)	0.1328	0	0	0	0	0.1328	0	0.1328	Tons (short)
Metal Wall Cladding - Commercial (26 Ga.)	sf	2863.5519	0	0	0	0	2863.552	0	1.4318	Tons (short)
Nails	Tons (short)	0.0389	0	0	0	0	0.0389	0	0.0389	Tons (short)
Paper Tape	Tons (short)	0.0015	0	0	0	0	0.0015	0	0.0015	Tons (short)
Rebar, Rod, Light Sections	Tons (short)	449.955	0	0	0	0	0	449.955	449.955	Tons (short)
Screws Nuts & Bolts	Tons (short)	1.8214	0	0	0	0	1.8214	0	1.8214	Tons (short)
Softwood Plywood	msf (3/8")	1.6497	0	0	0	0	1.6497	0	0.7981	Tons (short)
Solvent Based Alkyd Paint	Gallons (us)	0.1557	0	0	0	0	0.1557	0	0.0005	Tons (short)
Spandrel Panel	Tons (short)	14.0306	0	0	0	0	14.0306	0	14.0306	Tons (short)
Water Based Latex Paint	Gallons (us)	9874.3301	0	0	0	0	82.3301	9792	30.902	Tons (short)

ENVIRONMENT: MATERIAL QUANTITY INPUT

Covered Wood - Bill of Materials

Bill of Materials Report

Project: GSA - COVERED WOOD

Material	Unit	Total Quantity	Columns & Beams	Floors	Foundations	Roofs	Walls	Extra Basic Materials	Mass Value	Mass Unit
3 mil Polyethylene	sf	1253.1584	0	0	0	0	1253.158	0	0.0096	Tons (short)
5/8" Fire-Rated Type X Gypsum Board	sf	175950.5	0	0	0	0	0	175950.5	189.377	Tons (short)
5/8" Gypsum Fibre Gypsum Board	sf	1299.4666	0	0	0	0	1299.467	0	1.8631	Tons (short)
5/8" Regular Gypsum Board	sf	126670.5	0	0	0	0	0	126670.5	133.4827	Tons (short)
Air Barrier	sf	1253.1584	0	0	0	0	1253.158	0	0.0078	Tons (short)
Aluminum Extrusion	Tons (short)	52.5241	0	0	0	0	52.5241	0	52.5241	Tons (short)
Concrete Benchmark 3000 psi	yd3	6579.3	0	0	0	0	0	6579.3	12717.7984	Tons (short)
Cross Laminated Timber	ft3	89652.953	0	0	0	0	0	89652.953	1330.5109	Tons (short)
EPDM membrane (black, 60 mil)	lbs	4358.2726	0	0	0	0	4358.273	0	2.1791	Tons (short)
Expanded Polystyrene	sf (1")	70.0731	0	0	0	0	70.0731	0	0.0052	Tons (short)
FG Batt R11-15	sf (1")	174252.451	0	0	0	0	174252.5	0	5.5864	Tons (short)
FG Batt R20	sf (1")	6702.725	0	0	0	0	6702.725	0	0.1849	Tons (short)
Galvanized Sheet	Tons (short)	0.1365	0	0	0	0	0.1365	0	0.1365	Tons (short)
Galvanized Studs	Tons (short)	0.3296	0	0	0	0	0.3296	0	0.3296	Tons (short)
Glazing Panel	Tons (short)	211.71	0	0	0	0	211.71	0	211.71	Tons (short)
GluLam Sections	ft3	11466.025	0	0	0	0	0	11466.025	142.1898	Tons (short)
Joint Compound	Tons (short)	0.1328	0	0	0	0	0.1328	0	0.1328	Tons (short)
Metal Wall Cladding - Commercial (26 Ga.)	sf	2863.5519	0	0	0	0	2863.552	0	1.4318	Tons (short)
Nails	Tons (short)	0.0389	0	0	0	0	0.0389	0	0.0389	Tons (short)
Paper Tape	Tons (short)	0.0015	0	0	0	0	0.0015	0	0.0015	Tons (short)
Rebar, Rod, Light Sections	Tons (short)	507.525	0	0	0	0	0	507.525	507.525	Tons (short)
Screws Nuts & Bolts	Tons (short)	1.8214	0	0	0	0	1.8214	0	1.8214	Tons (short)
Softwood Plywood	msf (3/8")	1.6497	0	0	0	0	1.6497	0	0.7981	Tons (short)
Solvent Based Alkyd Paint	Gallons (us)	0.1557	0	0	0	0	0.1557	0	0.0005	Tons (short)
Spandrel Panel	Tons (short)	14.0306	0	0	0	0	14.0306	0	14.0306	Tons (short)
Water Based Latex Paint	Gallons (us)	1551.1301	0	0	0	0	82.3301	1468.8	4.8543	Tons (short)

ENVIRONMENT: MATERIAL QUANTITY INPUT

Rebar Quantities - Steel

FOUNDATIONS													
Description	Dimensions	COUNT	SF	CF	CY	Reduction	Rebar type	Rebar Weight/LF	Rebar LF / SF	Depth Factor	Rebar lbs per CY	Total Rebar Weight (lbs)	Rebar Tons
Spread Footings at Columns	10' x 10' x 42"	12		4630	171.4815	0	(20) #7	2.04	2	0.1296296	31.47428571	5397.257143	2.698628571
Continuous Wall Footing	48" x 36"	-		7063.4	261.6074	0	(3) #5 continuous	1.04	1	0.1111111	9.36	2448.645333	1.224322667
Shear Wall Footing	4' Deep	-		23000	851.8519	0	#9 top & bottom 5" OC	3.4	6	0.1851852	110.16	93840	46.92
					851.8519	0	#7 Top 7" OC	2.04	2	0.1851852	22.032	18768	9.384
					851.8519	0	#8 Bottom 10" OC	2.67	2	0.1851852	28.836	24564	12.282
Crane Pad	Sub bid				200	0	#9 top & bottom 5" OC	3.4	6	0.1851852	110.16	22032	11.016
					200	0	#7 Top 7" OC	2.04	2	0.1851852	22.032	4406.4	2.2032
					200	0	#8 Bottom 10" OC	2.67	2	0.1851852	28.836	5767.2	2.8836
4" SOG			20063	6680.979	247.4437	0	6x6 W1.4xW1.4 WWM	21	0	0	0	4213.23	2.106615
12" PT Deck			38823	38823	1437.889	0	#5, 36" OC, #5, 12" OC	1.04	3	0.037037	84.24	121127.76	60.56388
					1437.889	0	#2, bundles of (7) 18" OC	0.17	21	0.037037	96.39	138598.11	69.299055
Concrete Walls	12"			22456.35	831.7167	0	#5, 18" OC, #5, 16" OC	1.04	4	0.037037	112.32	93418.416	46.709208
12" Shear core wall	12" Wide			27464.14	1017.19	0	#6, 12" OC	1.5	2	0.037037	81	82392.42	41.19621
					1017.19	0	#5 6" OC	1.04	4	0.037037	112.32	114250.8224	57.1254112
Concrete Columns	12" x 18"	12		352.5	13.05556	0	(12) #7	2.04	12	0.0555556	440.64	5752.8	2.8764
					13.05556	0	#4 at 4 1/2" OC, #4 at 5" OC	0.67	6	0.0555556	72.36	944.7	0.47235
15% Connections		15%											55.34413207
10% Waste		10%											36.89608804
												TOTAL:	461.2011005

Includes : Rebar, formwork, labor & equipment

ENVIRONMENT: MATERIAL QUANTITY INPUT

Rebar Quantities - Wood

FOUNDATIONS													
Description	Dimensions	COUNT	SF	CF	CY	Reduction	Rebar type	Rebar Weight/LF	Rebar LF / SF	Depth Factor	Rebar lbs per CY	Total Rebar Weight (lbs)	Rebar Tons
Spread Footings at Columns	10' x 10' x 42"	20		7717.5	285.8331	170.54888	(20) #7	2.04	2	0.1296296	31.47428571	5367.904143	2.683952071
Continuous Wall Footing	48" x 36"	-		7063.4	261.6074	156.09394	(3) #5 continuous	1.04	1	0.11111111	9.36	1461.039241	0.730519621
Shear Wall Footing	4' Deep	-		24000	888.8889	530.37552	#9 top & bottom 5" OC	3.4	6	0.1851852	110.16	58426.16754	29.21308377
						530.37552	#7 Top 7" OC	2.04	2	0.1851852	22.032	11685.23351	5.842616754
						530.37552	#8 Bottom 10" OC	2.67	2	0.1851852	28.836	15293.90856	7.646954281
Crane Pad	Sub bid				200	0	#9 top & bottom 5" OC	3.4	6	0.1851852	110.16	22032	11.016
					200	0	#7 Top 7" OC	2.04	2	0.1851852	22.032	4406.4	2.2032
					200	0	#8 Bottom 10" OC	2.67	2	0.1851852	28.836	5767.2	2.8836
4" SOG			20063	6680.979	247.4437	0	6x6 W1.4xW1.4 WWM	21	0	0	0	4213.23	2.106615
12" PT Deck			38480	38480	1425.185	0	#5, 36" OC, #5, 12" OC	1.04	3	0.037037	84.24	120057.6	60.0288
					1425.185	0	#2, bundles of (7) 18" OC	0.17	21	0.037037	96.39	137373.6	68.6868
Concrete Walls	12"			21941.45	812.6463	0	#5, 18" OC, #5, 16" OC	1.04	4	0.037037	112.32	91276.432	45.638216
12" Shear core wall	12" Wide			28474	1054.593	0	#6, 12" OC	1.5	2	0.037037	81	85422	42.711
					1054.593	0	#5 6" OC	1.04	4	0.037037	112.32	118451.84	59.22592
Concrete Columns	12" x 18"	20		587.5	21.75926	12.983151	(12) #7	2.04	12	0.0555556	440.64	5720.895572	2.860447786
					357.2771	0	#4 at 4 1/2" OC, #4 at 5" OC	0.67	6	0.0555556	72.36	25852.57417	12.92628709
15% Connections		15%											53.46060186
10% Waste		10%											35.64040124
												TOTAL:	445.5050155

Includes : Rebar, formwork, labor & equipment
 Reduction Factor = 0.596672463

ENVIRONMENT: CREDITS

Research Guides

Athena Impact Estimator 5.1

500 Fairview Drawings

GLY, Courtesy of Ezekiel
Jones, Student, UW

Kathrina Simonen

AIA, SE, LEED-AP
Associate Professor
Mithun/Russell Family Foundation
Endowed Professor of Sustainability



In all, the purpose of this thesis was to understand the implications of mass timber as an alternative primary structural material for office buildings in Seattle, assuming that current building code limitations on the height of mass timber structures is lifted. Aesthetically, wood provides for a warmer, and more inviting atmosphere, both as seen from the exterior (shown above) and exposed in the interior spaces (see Chapter Four). For the GSA, an exposed wood structure and interior finishes system appears to include a cost savings. However, for most other developers, switching to wood would require an investment. Because the wood structure for this particular structural system does not provide a schedule savings, it makes it that much harder to push the material out into the market. It's possible that manufacturing CLT locally will lower the price of the panel per square foot, which may shift the market in the favor of wood. In terms of the schedule, there may be ways to use the prefabricated nature of the CLT panel to speed up construction time on site.

Given that this is only a 2 quarter long exploration, there quite a few limitations to this analysis. Many costs and schedule impacts have been assumed to be held constant, because the design has not reached a level where a more detailed cost analysis or scheduling analysis could be produced. Taking this project even further and getting into the details, such as looking at impacts on MEP trades, optimization of wood building, etc could yield considerably different results. Michael green (6 stories tilt up).

CONCLUSION:

OPPORTUNITIES FOR FURTHER STUDY

While this overview presents a brief overview of the potential impacts of a mass timber structure on design, cost, schedule & environment, further study is needed to fully understand the implications of mass timber on the building market. Some ideas/opportunities for further exploration include:

1. CLT instead of concrete as a shear core
What are the schedule & cost implications?
2. Most efficient use of CLT panel system construction.
3. How high can you build with wood? Tallest wood structure exploration.
4. Mass timber and the building code: fire & life safety concerns, vibration, weather proofing & shrinkage, etc.
5. CLT in the pacific northwest - exploration of market drivers and socio-economic incentives for implementation.
6. Wood/Steel/Concrete Hybrid structures and potential advantages
7. Exploration of cost implications for CLT in other building markets (aka. residential, industrial, smaller scale commercial, etc)
8. Mass timber and MEP systems. How can these be optimized to work best together?
9. And many more!



Mariam Hovhannisyan <mariamhovhan@gmail.com>

UW Washington Thesis - Estimate Request

3 messages

Mariam Hovhannisyan <mariamhovhan@gmail.com>

Mon, Oct 19, 2015 at 1:02 PM

To: rich@mcciron.com

Hi,

My name is Mariam and I am a student at the UW working on my Master's in Architecture Thesis. I am comparing a structural steel office building to a mass timber office building and was hoping that you could provide me with some quick pricing metrics to use. I know that it's a very busy market right now, but even a ROM would be a great help!

About the Project

It is a typical, 7 story open plan office building to be located in downtown Seattle's South Lake Union district (on Fairview and Republican - there is a current project under construction there). The grid for the structural steel option is roughly 30' x 30' with 2 levels of concrete parking below.

Pricing I need and applicable assumptions:

Please include supply & install, connections, embeds and any equipment (not including a tower crane) for the following scopes of work:

1. W14x174 steel columns = **97.5 tons**
2. W18x60 Girders = **88 tons**
3. W18x35 beams = **243 tons**
4. Corrugated metal deck (20 gauge), 3" corrugation = **115,155 SF**
5. **How long will steel erection take for this project?**
6. **What are typical lead times?**

See attached documents for schematic structural plans.

Thank you & hope to hear from you soon,

Mariam

**Structural Plan - Thesis.pdf**

389K

Rich McClean <Rich@mcciron.com>

Mon, Oct 19, 2015 at 1:08 PM

To: Mariam Hovhannisyan <mariamhovhan@gmail.com>

[See below for budget numbers](#)

Thank you,

Richard McClean

MCCLEAN IRON WORKS

2102 Ross Avenue Everett, WA 98201

(425) 493-5525

(425) 493-5520 fax

(206) 396-8728 cell

rich@mcciron.com

This e-mail originated from McClean Iron Works and has been scanned for content and viruses. This e-mail and its attachments contain confidential, proprietary, and/or privileged information and are intended for the exclusive use of the addressee. If you are not the intended recipient, please notify the sender of this e-mail and delete or otherwise destroy every electronic, paper, or other copy of this message and all attachments.

From: Mariam Hovhannisyan [mailto:mariamhovhan@gmail.com]
Sent: Monday, October 19, 2015 1:03 PM
To: Rich McClean
Subject: UW Washington Thesis - Estimate Request

Hi,

My name is Mariam and I am a student at the UW working on my Master's in Architecture Thesis. I am comparing a structural steel office building to a mass timber office building and was hoping that you could provide me with some quick pricing metrics to use. I know that it's a very busy market right now, but even a ROM would be a great help!

About the Project

It is a typical, 7 story open plan office building to be located in downtown Seattle's South Lake Union district (on Fairview and Republican - there is a current project under construction there). The grid for the structural steel option is roughly 30' x 30' with 2 levels of concrete parking below.

Pricing I need and applicable assumptions:

Please include supply & install, connections, embeds and any equipment (not including a tower crane) for the following scopes of work:

1. W14x174 steel columns = **97.5 tons**
2. W18x60 Girders = **88 tons**
3. W18x35 beams = **243 tons**

Struct Framing S&I \$2,500,000

4. Corrugated metal deck (20 gauge), 3" corrugation = **115,155 SF**

Metal Decking S&I \$375,000

5. **How long will steel erection take for this project?--8-10 weeks**
6. **What are typical lead times? Drawings 6-8 weeks, Fab 10 weeks**

See attached documents for schematic structural plans.

Thank you & hope to hear from you soon,

Mariam

Mariam Hovhannisyan <mariamhovhan@gmail.com>

Mon, Oct 19, 2015 at 1:37 PM

To: Rich McClean <Rich@mcciron.com>

Thank you for the quick response Rich!

Can you also provide me with a number for the steel connections of the mass timber option?

Thanks again!

Mariam

[Quoted text hidden]



Mariam Hovhannisyan <mariamhovhan@gmail.com>

UW Washington Thesis - Estimate Request

5 messages

Mariam Hovhannisyan <mariamhovhan@gmail.com>

Mon, Oct 19, 2015 at 1:00 PM

To: Mariam Hovhannisyan <mariamhovhan@gmail.com>, carey@rfstearns.com

Hi,

My name is Mariam and I am a student at the UW working on my Master's in Architecture Thesis. I am comparing a structural steel office building to a mass timber office building and was hoping that you could provide me with some quick pricing metrics to use. I know that it's a very busy market right now, but even a ROM would be a great help!

About the Project

It is a typical, 7 story open plan office building to be located in downtown Seattle's South Lake Union district (on Fairview and Republican - there is a current project under construction there). The grid for the structural steel option is roughly 30' x 30' with 2 levels of concrete parking below.

Pricing I need and applicable assumptions:

Please include supply & install, connections, embeds and any equipment (not including a tower crane) for the following scopes of work:

1. W14x174 steel columns = **97.5 tons**
2. W18x60 Girders = **88 tons**
3. W18x35 beams = **243 tons**
4. Corrugated metal deck (20 gauge), 3" corrugation = **115,155 SF**
5. **How long will steel erection take for this project?**
6. **What are typical lead times?**

See attached documents for schematic structural plans.

Thank you & hope to hear from you soon,

Mariam

**Structural Plan - Thesis.pdf**

389K

Carey Lee <clee@rfstearns.com>

Mon, Oct 19, 2015 at 1:50 PM

To: Mariam Hovhannisyan <mariamhovhan@gmail.com>

I can throw you a ROM at it.

- Detailing will run around \$.50 a square foot
- Columns, girders & beams run around \$ 2,200/ton (we look at it on a unit cost basis – not per item).
- Decking is \$ 120.00 per Square (or a \$ 1.20 per sqft).
- Stairs will be \$ 450.00 per tread (supply & install – you will need this in both designs).
- Erection is \$ 4.50 to \$ 5.00 a square foot...

Hope this helps.

Carey Lee

Chief Estimator

]STEARNS[

P: [503.601.8700](tel:503.601.8700)

D: [503.601.8703](tel:503.601.8703)

C: [503.367.3200](tel:503.367.3200)

4000 Kruse Way Place

Building 3, Suite 100

Lake Oswego, OR 97035

clee@rfstearns.com

www.rfstearns.com

CCB 78706

From: Mariam Hovhannisyan [mailto:mariamhovhan@gmail.com]

Sent: Monday, October 19, 2015 1:01 PM

To: Mariam Hovhannisyan; Carey Lee

Subject: UW Washington Thesis - Estimate Request

[Quoted text hidden]

The contents of this message, together with any attachments, are intended only for the use of the individual or entity to which they are addressed and may contain information that is legally privileged, confidential and exempt from disclosure. If you are not the intended recipient, you are hereby notified that any dissemination, distribution, or copying of this message, or any attachment, is strictly prohibited. If you have received this message in error, please notify the original sender immediately by telephone or by return E-mail and delete this message, along with any attachments, from your computer. Thank you, R.F. Stearns, Inc.

Mariam Hovhannisyan <mariamhovhan@gmail.com>

Mon, Oct 19, 2015 at 1:54 PM

To: Carey Lee <clee@rfstearns.com>

Thanks so much for your help Carey! Would you be able to ROM a price for steel connections on the wood option as well? I forgot to include that in my list!

Thanks again!

Mariam

[Quoted text hidden]

Carey Lee <clee@rfstearns.com>

Mon, Oct 19, 2015 at 2:00 PM

To: Mariam Hovhannisyan <mariamhovhan@gmail.com>

Sorry,

I do not have any history working with wood structures to go off of.

You can ask Jake Sly at R & H construction....They just completed a project using wood timbers.

I have attached his V-card for you. You can blame me for telling you he would help you J.

Carey

From: Mariam Hovhannisyan [mailto:mariamhovhan@gmail.com]

Sent: Monday, October 19, 2015 1:54 PM

To: Carey Lee

Subject: Re: UW Washington Thesis - Estimate Request

[Quoted text hidden]

 **Jake Sly.vcf**
1K

Mariam Hovhannisyan <mariamhovhan@gmail.com>

To: Carey Lee <clee@rfstearns.com>

Mon, Oct 19, 2015 at 2:02 PM

Haha! Thanks Carey

[Quoted text hidden]



Mariam Hovhannisyan <mariamhovhan@gmail.com>

University of Washington Thesis - Estimate Request

3 messages

Mariam Hovhannisyan <mariamhovhan@gmail.com>

Fri, Oct 23, 2015 at 3:21 PM

To: kent@northcoastiron.com

Hi Kent!

This is Mariam from Rafn. I am also a student at the UW working on my Master's in Architecture Thesis. I am comparing a structural steel office building to a mass timber office building and was hoping that you could provide me with some quick pricing metrics to use. I know that it's a very busy market right now, but even a ROM would be a great help!

About the Project

It is a typical, 7 story open plan office building to be located in downtown Seattle's South Lake Union district (on Fairview and Republican - there is a current project under construction there). The grid for the structural steel option is roughly 30' x 30' with 2 levels of concrete parking below.

Pricing I need and applicable assumptions:

Please include supply & install, connections, embeds and any equipment (not including a tower crane) for the following scopes of work:

1. W14x174 steel columns = **97.5 tons**
2. W18x60 Girders = **88 tons**
3. W18x35 beams = **243 tons**
4. Corrugated metal deck (20 gauge), 3" corrugation = **115,155 SF**
5. Steel connections for the wood option - **LS**
6. **How long will steel erection take for this project?**
7. **What are typical lead times?**

See attached documents for schematic structural plans.

Thank you & hope to hear from you soon!

Mariam

**Structural Plan - Thesis.pdf**

389K

Kent Schluter <kent@northcoastiron.com>

Sun, Oct 25, 2015 at 3:59 PM

To: Mariam Hovhannisyan <mariamhovhan@gmail.com>

Mariam:

I didn't see the attachment but find my response in general terms.

Kent

From: Mariam Hovhannisyan [mailto:mariamhovhan@gmail.com]
Sent: Friday, October 23, 2015 3:22 PM
To: kent@northcoastiron.com
Subject: University of Washington Thesis - Estimate Request

Hi Kent!

This is Mariam from Rafn. I am also a student at the UW working on my Master's in Architecture Thesis. I am comparing a structural steel office building to a mass timber office building and was hoping that you could provide me with some quick pricing metrics to use. I know that it's a very busy market right now, but even a ROM would be a great help!

About the Project

It is a typical, 7 story open plan office building to be located in downtown Seattle's South Lake Union district (on Fairview and Republican - there is a current project under construction there). The grid for the structural steel option is roughly 30' x 30' with 2 levels of concrete parking below.

Pricing I need and applicable assumptions:

Please include supply & install, connections, embeds and any equipment (not including a tower crane) for the following scopes of work:

1. W14x174 steel columns = **97.5 tons = about \$4,000.00 per ton Primed and Erected**
2. W18x60 Girders = **88 tons = about \$4000.00 per Ton Primed and Erected**
3. W18x35 beams = **243 tons = about \$400.00 per Ton Primed and Erected**
4. Corrugated metal deck (20 gauge), 3" corrugation = **115,155 SF = about \$3.00 per sq ft installed**
5. Steel connections for the wood option – **LS = 10% of the above weights add the \$4,000.00 per ton for fabrication and install**
6. **How long will steel erection take for this project? Real Site Schedule would be 40-45 work days of steel on critical path**
7. **What are typical lead times? Detailing time needs to start not later then breaking ground. Steel types listed above are readily available. If fabricator wanted to go mill direct add 30-40 day lead time**

See attached documents for schematic structural plans.

Thank you & hope to hear from you soon!

Mariam

Mariam Hovhannisyan <mariamhovhan@gmail.com>
To: Kent Schluter <kent@northcoastiron.com>

Sun, Oct 25, 2015 at 4:03 PM

Thanks Kent!!

Mariam

[Quoted text hidden]



Mariam Hovhannisyan <mariamhovhan@gmail.com>

FW: University of Washington - Master's Thesis

1 message

Kris Spickler <kspickler@structurlam.com>

Fri, Jun 26, 2015 at 9:29 AM

To: "mariamhovhan@gmail.com" <mariamhovhan@gmail.com>

Mariam,

It has been a few months since we last spoke. Looks like you still need more information. Not much has changed since the last round of info I sent. See attached.

Kris Spickler | Heavy Timber Specialist
Heavy Timber Group - Structurlam Products LP
4120 Douglas Blvd. #306-502 | Granite Bay, CA 95746
Office: (916) 797-5588 | Mobile: (916) 759-9320
Email address: kspickler@structurlam.com
website: www.structurlam.com
CrossLamTM by Structurlam

-----Original Message-----

From: Stephen Tolnai

Sent: Thursday, June 25, 2015 8:46 AM

To: Kris Spickler

Subject: FW: University of Washington - Master's Thesis

Stephen Tolnai | Director – Sales and Marketing _____

Structurlam Products LP

2176 Government Street | Penticton BC | V2A 8B5

T: (250) 492-8912 | F: (250) 492-8906 | M: (250) 462-0408 www.structurlam.com CrossLamTM by Structurlam:

Certified to PRG-320

-----Original Message-----

From: Mariam Hovhannisyan [mailto:mariamhovhan@gmail.com]

Sent: Thursday, June 25, 2015 7:45 AM

To: Sales - Structurlam

Subject: University of Washington - Master's Thesis

From: Mariam Hovhannisyan <mariamhovhan@gmail.com>

Subject: University of Washington - Master's Thesis

Company: University of Washington

Message Body:

Hi,

My name is Mariam Hovhannisyan and I am a Masters of Architecture student at the University of Washington working on a thesis based on designing a 10 story commercial office building using CLT, which will be 'built' in Seattle. The purpose of the thesis is to gauge the feasibility (in terms of cost and schedule implications) of such a

building project here in the States. I was hoping that I may be able to obtain information relating to costs, lead times, manufacturing process, and anything else that you may be able to help me with.

I hope to hear from you soon!

Mariam

--

This e-mail was sent from a contact form on Structurlam Wood Prodcuts (<http://structurlam.com/>)

----- Forwarded message -----

From: Kris Spickler <kspickler@structurlam.com>

To: "mariamhovhan@gmail.com" <mariamhovhan@gmail.com>

Cc:

Date: Tue, 28 Apr 2015 16:33:24 -0700

Subject: RE: Master's Thesis

Mariam,

Here is some of the information you requested:

Design Guide - attached

PPT on construction - attached

Costs:

CrossLam SPF Floor/Roof Pricing per sq ft

CrossLam SLT3 (4.1") = \$9.84

CrossLam SLT5(6.7") = \$16.00

CrossLam SLT7 (9.4") = \$21.60

CrossLam SLT9 (12.2") = \$27.42

These numbers include freight to Seattle, shop drawings, simple shape/spline framing, wrapped

Optional Visual Grade.....add \$0.95/sq ft

Schedule:

6 weeks for shop drawings

2 weeks for approval

8 weeks for delivery

Based floor footprint of 12,000 sq ft, for a 10 story Building

Manufacturing:

2x6 SPF #2 and better lamstock dried to 12% MC

Finger jointed to 10' and 40'

10' x 40' mechanical press with Purbond adhesive

Framed by a Hundegger PBA CNC machine

Wrapped and ship to site

I hope this helps,

Kris Spickler | Heavy Timber Specialist

Heavy Timber Group - Structurlam Products LP

4120 Douglas Blvd. #306-502 | Granite Bay, CA 95746

Office: (916) 797-5588 | Mobile: (916) 759-9320

Email address: kspickler@structurlam.com

website: www.structurlam.com

CrossLamTM by Structurlam

-----Original Message-----

From: Stephen Tolnai
Sent: Monday, April 27, 2015 12:00 PM
To: Kris Spickler
Subject: FW: Master's Thesis

Stephen Tolnai | Director – Sales and Marketing _____

Structurlam Products LP
2176 Government Street | Penticton BC | V2A 8B5
T: (250) 492-8912 | F: (250) 492-8906 | M: (250) 462-0408 www.structurlam.com CrossLam™ by Structurlam:
Certified to PRG-320

-----Original Message-----

From: Mariam Hovhannisyan [mailto:mariamhovhan@gmail.com]
Sent: Saturday, April 25, 2015 12:44 PM
To: Sales - Structurlam
Subject: Master's Thesis

From: Mariam Hovhannisyan <mariamhovhan@gmail.com>
Subject: Master's Thesis
Company: University of Washington

Message Body:

Hi,

My name is Mariam Hovhannisyan and I am a Masters of Architecture student at the University of Washington working on a thesis based on designing a 10 story commercial office building using CLT to be built in Seattle and the feasibility (in terms of cost and schedule implications) of such a building project here in the States. I was hoping that I may be able to speak with a representative regarding costs, lead times, manufacturing process, and anything else that you may be able to help me with.

I hope to hear from you soon!

Mariam

--

This e-mail was sent from a contact form on Structurlam Wood Prodcuts (<http://structurlam.com/>)

2 attachments

 **CrossLam Construction Presentation 11-18-14.pdf**
4282K

 **CrossLam design guide imperial 1-16-15 LR.pdf**
709K



Mariam Hovhannisyan <mariamhovhan@gmail.com>

University of Washington - Master's Thesis

3 messages

Mariam Hovhannisyan <mariamhovhan@gmail.com>

Mon, Oct 19, 2015 at 1:38 PM

To: bill@alkilumber.com

Hi,

My name is Mariam and I am a student at the UW working on my Master's in Architecture Thesis. I am comparing a structural steel office building to a mass timber office building and was hoping that you could provide me with some quick pricing metrics to use. I know that it's a very busy market right now, but even a ROM would be a great help!

About the Project

It is a typical, 7 story open plan office building to be located in downtown Seattle's South Lake Union district (on Fairview and Republican - there is a current project under construction there). The grid for the structural steel option is roughly 30' x 30' with 2 levels of concrete parking below. The grid for the mass timber option is roughly 20' x 30' with CLT spanning in the 20' direction.

Pricing I need and applicable assumptions:

Please include supply of the following - current \$:

1. Glulam columns (10.75" x 18") 30 ft long - **\$/EA**
2. Glulam columns (10.75" x 18") 15 ft long - **\$/EA**
3. Glulam Girders (6.75" x 40.5") ~30 ft long - **\$/EA**
4. **What are the lead time on these items?**

See attached documents for schematic structural plans.

Thank you & hope to hear from you soon,

Mariam

**Structural Plan - Thesis.pdf**

389K

Bill Boender <Bill@alkilumber.com>

Mon, Oct 19, 2015 at 4:00 PM

To: Mariam Hovhannisyan <mariamhovhan@gmail.com>

[Prices are below](#)[thanks](#)**From:** Mariam Hovhannisyan [mailto:mariamhovhan@gmail.com]**Sent:** Monday, October 19, 2015 1:39 PM**To:** Bill Boender <Bill@alkilumber.com>**Subject:** University of Washington - Master's Thesis

Hi,

My name is Mariam and I am a student at the UW working on my Master's in Architecture Thesis. I am comparing a structural steel office building to a mass timber office building and was hoping that you could provide me with some quick pricing metrics to use. I know that it's a very busy market right now, but even a ROM would be a great help!

About the Project

It is a typical, 7 story open plan office building to be located in downtown Seattle's South Lake Union district (on Fairview and Republican - there is a current project under construction there). The grid for the structural steel option is roughly 30' x 30' with 2 levels of concrete parking below. The grid for the mass timber option is roughly 20' x 30' with CLT spanning in the 20' direction.

Pricing I need and applicable assumptions:

Please include supply of the following - current \$:

1. Glulam columns (10.75" x 18") 30 ft long - **\$/EA \$1,469.10**
2. Glulam columns (10.75" x 18") 15 ft long - **\$/EA \$734.55**
3. Glulam Girders (6.75" x 40.5") ~30 ft long - **\$/EA \$1,944.00**
4. **What are the lead time on these items?**

See attached documents for schematic structural plans.

Thank you & hope to hear from you soon,

Mariam

Mariam Hovhannisyan <mariamhovhan@gmail.com>

To: Bill Boender <Bill@alkilumber.com>

Mon, Oct 19, 2015 at 7:03 PM

Thank you so much for your help!

Mariam

[Quoted text hidden]



Mariam Hovhannisyan <mariamhovhan@gmail.com>

RE: University of Washington Thesis - Estimate Request

7 messages

Dave Neiger <dave@matheuslumber.com>

Mon, Oct 26, 2015 at 8:49 AM

To: Susan Jones <Susan@atelierjones.com>, Mariam Hovhannisyan <mariamhovhan@gmail.com>

Hi Susan,

Thank you for connecting. I will certainly reach out when the time is right. Kris Spickler with Structurelam will be doing a presentation on CLT for the American Society of Professional Estimators. If you'd like to join the program, I've attached the invitation.

Thank you!

Dave

From: Susan Jones [mailto:Susan@atelierjones.com]
Sent: Friday, October 23, 2015 4:13 PM
To: Mariam Hovhannisyan; Dave Neiger
Subject: RE: University of Washington Thesis - Estimate Request

Hi Mariam, hi Dave,

Many thanks for the reference, Mariam. There has been a lot of coverage about our new CLHouse in Seattle – let me know if there is anything I can provide for you, Dave. In the meantime, Mariam is correct, our panels were sourced, CNC-fabricated and shipped from Structurlam in Penticton, BC. We have one completed project, our house, and another, a non-structural panel usage in Bellevue for a church. Let me know if we can help in anyway.

We've enjoyed working with it!

Many thanks.

Susan

Susan H. Jones, FAIA, LEED AP **atelierjones llc**

office 911 Western Avenue Suite 440 Seattle, WA 98104

office 206.624.9966 fax 206.624.9957 mobile 206.601.5242

susan@atelierjones.com www.atelierjones.com

From: Mariam Hovhannisyan [<mailto:mariamhovhan@gmail.com>]
Sent: Friday, October 23, 2015 4:01 PM
To: Dave Neiger <dave@matheuslumber.com>; Susan Jones <Susan@atelierjones.com>
Subject: Re: University of Washington Thesis - Estimate Request

Dave,

You can contact Architect Susan Jones for more information about the CLT product (email: susan@atelierjones.com). She designed her personal home using CLT panels as wall, floor and roofing material. I believe she used Structurelam for sourcing the panels. Let her know that I recommended you!

Hope that helps,

Mariam

On Fri, Oct 23, 2015 at 10:06 AM, Dave Neiger <dave@matheuslumber.com> wrote:

4pm works. Your timing is impeccable, I am on the board for the American Society of Professional Estimators and I am spearheading our November program on CLT, the invitation is attached. When you register, make sure you select the student option. I've forwarded your inquiry to the speaker for this event.

If I'm not in the office at 4pm, call me on my cell at [425-232-3718](tel:425-232-3718).

Dave

From: Mariam Hovhannisyan [<mailto:mariamhovhan@gmail.com>]
Sent: Friday, October 23, 2015 9:54 AM
To: Dave Neiger
Subject: RE: University of Washington Thesis - Estimate Request

Sounds good! Can I call you around 4pm?

Mariam

On Oct 23, 2015 9:52 AM, "Dave Neiger" <dave@matheuslumber.com> wrote:

Hi Mariam,

Give me a call. I've got plenty of info for you but email will be a little too cumbersome as a communication medium.

Dave

800-284-7501

From: Mariam Hovhannisyan [mailto:mariamhovhan@gmail.com]
Sent: Friday, October 23, 2015 9:08 AM
To: Dave Neiger
Subject: University of Washington Thesis - Estimate Request

Hi,

My name is Mariam and I am a student at the UW working on my Master's in Architecture Thesis. I am comparing a structural steel office building to a mass timber office building and was hoping that you could provide me with some quick pricing metrics to use. I know that it's a very busy market right now, but even a ROM would be a great help!

About the Project

It is a typical, 7 story open plan office building to be located in downtown Seattle's South Lake Union district (on Fairview and Republican - there is a current project under construction there). The grid for the structural steel option is roughly 30' x 30' with 2 levels of concrete parking below. The grid for the mass timber option is roughly 20' x 30' with CLT spanning in the 20' direction.

Pricing I need and applicable assumptions:

Please include install, install of connections, any equipment (not including the tower crane), mark-ups of the following - current \$:

1. Glulam columns (10.75" x 18") 30 ft long - **\$/EA**
2. Glulam columns (10.75" x 18") 15 ft long - **\$/EA**
3. Glulam Girders (6.75" x 40.5") ~30 ft long - **\$/EA**
4. CLT (7 layer) will need to be screwed into place - **115,155 SF total \$**

See attached documents for schematic structural plans.

Thank you & hope to hear from you soon,

Mariam



ASPE NOV 2015 Invite.doc

313K

Mariam Hovhannisyan <mariamhovhan@gmail.com>
To: Dave Neiger <dave@matheuslumber.com>

Mon, Oct 26, 2015 at 8:56 AM

Dave,

Could you provide me with some pricing for the following?

[Quoted text hidden]

Mariam Hovhannisyan <mariamhovhan@gmail.com>

Mon, Oct 26, 2015 at 8:57 AM

To: Dave Neiger <dave@matheuslumber.com>

Sorry! Forgot to copy them:

1. Glulam columns (10.75" x 18") 30 ft long - **\$/EA**
2. Glulam columns (10.75" x 18") 15 ft long - **\$/EA**
3. Glulam Girders (6.75" x 40.5") ~30 ft long - **\$/EA**

Mariam

[Quoted text hidden]

Dave Neiger <dave@matheuslumber.com>

Mon, Oct 26, 2015 at 10:25 AM

To: Mariam Hovhannisyan <mariamhovhan@gmail.com>

1. Glulam columns (10.75" x 18") 30 ft long @ \$745.20/ea
2. Glulam columns (10.75" x 18") 15 ft long @ \$372.60/ea
3. Glulam Girders (6.75" x 40.5") ~30 ft long @ \$1,039.20/ea

Do you know how many pieces of each you'll need? It'll cost an additional 600 per truckload to deliver to the jobsite.

Dave

From: Mariam Hovhannisyan [mailto:mariamhovhan@gmail.com]

Sent: Monday, October 26, 2015 8:58 AM

To: Dave Neiger

[Quoted text hidden]

[Quoted text hidden]

Mariam Hovhannisyan <mariamhovhan@gmail.com>

Mon, Oct 26, 2015 at 10:35 AM

To: Dave Neiger <dave@matheuslumber.com>

Thanks Dave!

I would need about 60 ea (28' columns) and 20 ea (20' columns) and about 155 ea of the girders.

Mariam

[Quoted text hidden]

Dave Neiger <dave@matheuslumber.com>

Mon, Oct 26, 2015 at 10:49 AM

To: Mariam Hovhannisyan <mariamhovhan@gmail.com>

You're looking at a shipping weight of about 575,000 pounds. Each truck can carry around 65,000 pounds. I would factor in about 11-12 trucks @ \$600/truck to account for the freight.

Dave

From: Mariam Hovhannisyan [mailto:mariamhovhan@gmail.com]

Sent: Monday, October 26, 2015 10:36 AM

[Quoted text hidden]

[Quoted text hidden]

Mariam Hovhannisyan <mariamhovhan@gmail.com>

Mon, Oct 26, 2015 at 10:51 AM

To: Dave Neiger <dave@matheuslumber.com>

Great! Thanks so much for your help Dave!

Mariam

[Quoted text hidden]



Mariam Hovhannisyan <mariamhovhan@gmail.com>

RE: Master's Thesis

15 messages

Kris Spickler <kspickler@structurlam.com>

Tue, Apr 28, 2015 at 4:33 PM

To: "mariamhovhan@gmail.com" <mariamhovhan@gmail.com>

Mariam,

Here is some of the information you requested:

Design Guide - attached

PPT on construction - attached

Costs:

CrossLam SPF Floor/Roof Pricing per sq ft

CrossLam SLT3 (4.1") = \$9.84

CrossLam SLT5(6.7") = \$16.00

CrossLam SLT7 (9.4") = \$21.60

CrossLam SLT9 (12.2") = \$27.42

These numbers include freight to Seattle, shop drawings, simple shape/spline framing, wrapped

Optional Visual Grade.....add \$0.95/sq ft

Schedule:

6 weeks for shop drawings

2 weeks for approval

8 weeks for delivery

Based floor footprint of 12,000 sq ft, for a 10 story Building

Manufacturing:

2x6 SPF #2 and better lamstock dried to 12% MC

Finger jointed to 10' and 40'

10' x 40' mechanical press with Purbond adhesive

Framed by a Hundegger PBA CNC machine

Wrapped and ship to site

I hope this helps,

Kris Spickler | Heavy Timber Specialist
Heavy Timber Group - Structurlam Products LP
4120 Douglas Blvd. #306-502 | Granite Bay, CA 95746
Office: (916) 797-5588 | Mobile: (916) 759-9320
Email address: kspickler@structurlam.com
website: www.structurlam.com
CrossLamTM by Structurlam

-----Original Message-----

From: Stephen Tolnai

Sent: Monday, April 27, 2015 12:00 PM

To: Kris Spickler

Subject: FW: Master's Thesis

Stephen Tolnai | Director – Sales and Marketing _____

Structurlam Products LP

2176 Government Street | Penticton BC | V2A 8B5

T: (250) 492-8912 | F: (250) 492-8906 | M: (250) 462-0408 www.structurlam.com CrossLam™ by Structurlam:
Certified to PRG-320

-----Original Message-----

From: Mariam Hovhannisyan [mailto:mariamhovhan@gmail.com]

Sent: Saturday, April 25, 2015 12:44 PM

To: Sales - Structurlam

Subject: Master's Thesis

From: Mariam Hovhannisyan <mariamhovhan@gmail.com>

Subject: Master's Thesis

Company: University of Washington

Message Body:

Hi,

My name is Mariam Hovhannisyan and I am a Masters of Architecture student at the University of Washington working on a thesis based on designing a 10 story commercial office building using CLT to be built in Seattle and the feasibility (in terms of cost and schedule implications) of such a building project here in the States. I was hoping that I may be able to speak with a representative regarding costs, lead times, manufacturing process, and anything else that you may be able to help me with.

I hope to hear from you soon!

Mariam

--

This e-mail was sent from a contact form on Structurlam Wood Prodcuts (<http://structurlam.com/>)

2 attachments



CrossLam Construction Presentation 11-18-14.pdf

4282K



CrossLam design guide imperial 1-16-15 LR.pdf

709K

mariamhovhan@gmail.com <mariamhovhan@gmail.com>

Wed, Apr 29, 2015 at 12:26 AM

To: Kris Spickler <kspickler@structurlam.com>

Hi Kris,

This is perfect! Thank you so much for your help. Would you be available as a contact should further questions arise?

Thanks again,

Mariam

Sent from my HTC EVO 4G LTE exclusively from Sprint

----- Reply message -----

From: "Kris Spickler" <kspickler@structurlam.com>

To: "mariamhovhan@gmail.com" <mariamhovhan@gmail.com>

Subject: Master's Thesis

[Quoted text hidden]

[Quoted text hidden]

mariamhovhan@gmail.com <mariamhovhan@gmail.com>

Wed, Apr 29, 2015 at 12:26 AM

To: Kris Spickler <kspickler@structurlam.com>

[Quoted text hidden]

Kris Spickler <kspickler@structurlam.com>

Wed, Apr 29, 2015 at 9:30 AM

To: "mariamhovhan@gmail.com" <mariamhovhan@gmail.com>

Yes.

From: mariamhovhan@gmail.com [mailto:mariamhovhan@gmail.com]

Sent: Wednesday, April 29, 2015 12:26 AM

To: Kris Spickler

Subject: Re: Master's Thesis

[Quoted text hidden]

Mariam Hovhannisyan <mariamhovhan@gmail.com>

Wed, Apr 29, 2015 at 11:59 AM

To: Kris Spickler <kspickler@structurlam.com>

Great, thanks!

Mariam

[Quoted text hidden]

Mariam Hovhannisyan <mariamhovhan@gmail.com>

Fri, Oct 23, 2015 at 4:08 PM

To: Kris Spickler <kspickler@structurlam.com>

Kris!

I heard about your seminar this coming November the 17th! Also, I wanted to follow up with you on my thesis project. I have developed some preliminary structural plans and I thought you might be interested in taking a look!

Currently, I have the following wood items included in my project:

- Glulam columns (10.75" x 18") 30ft to 15ft long
- Glulam Girders (6.75" x 40.5") ~30 ft long
- CLT Panels (7 layers, no topping slab) 10 ft wide and spanning 20'.

I have pricing from you on the CLT panels, but I was wondering if you could help out with some pricing on the other pieces? I spoke to Dave Neiger with Matheus Lumber and he recommended that I reach out to you with my design.

Let me know if you see something that's really off. I had a hard time finding the right glulam column for a project this size, so let me know if you have any recommendations.

On Wed, Apr 29, 2015 at 9:30 AM, Kris Spickler <kspickler@structurlam.com> wrote:

[Quoted text hidden]



Structural Plan - Thesis.pdf

389K

Kris Spickler <kspickler@structurlam.com>
To: Mariam Hovhannisyan <mariamhovhan@gmail.com>

Fri, Oct 23, 2015 at 8:08 PM

Will do. Headed home from Seattle right now. So Monday or Tuesday

Kris Spickler
Sent from my flip phone

[Quoted text hidden]

| <Structural Plan - Thesis.pdf>

Kris Spickler <kspickler@structurlam.com>
To: Mariam Hovhannisyan <mariamhovhan@gmail.com>

Wed, Oct 28, 2015 at 9:08 AM

Marian,

Happy to help. I'll get you some prices on this products. Do you have any quantities I can use? I need to build in shipping costs as well, where would this ship to?

Kris Spickler | Heavy Timber Specialist

Heavy Timber Group - Structurlam Products LP

4120 Douglas Blvd. #306-502 | Granite Bay, CA 95746

Office: (916) 797-5588 | Mobile: (916) 759-9320

Email address: kspickler@structurlam.com

website: www.structurlam.com

CrossLam™ by Structurlam

From: Mariam Hovhannisyan [mailto:mariamhovhan@gmail.com]

Sent: Friday, October 23, 2015 4:09 PM

To: Kris Spickler <kspickler@structurlam.com>

[Quoted text hidden]

[Quoted text hidden]

Mariam Hovhannisyan <mariamhovhan@gmail.com>
To: Kris Spickler <kspickler@structurlam.com>

Wed, Oct 28, 2015 at 9:15 AM

Kris, see below:

- Glulam columns (10.75" x 18") 30ft - **60 EA**
- Glulam columns (10.75" x 18") 20ft - **20 EA**
- Glulam Girders (6.75" x 40.5") ~30 ft long - **155 EA**
- CLT Panels (7 layers, no topping slab) 10 ft wide and spanning 20' - **115,155 SF**

Ship to: **500 Fairview Ave, Seattle WA**

Thanks again,

Mariam

[Quoted text hidden]

Kris Spickler <kspickler@structurlam.com>
To: Mariam Hovhannisyan <mariamhovhan@gmail.com>

Wed, Oct 28, 2015 at 9:20 AM

I'll put this together for you and break down all the costs. The actual material is only 2/3 of the cost to develop a system for mid-rise. I'm in Portland the rest of the week, so it will be next week is that ok?

From: Mariam Hovhannisyan [mailto:mariamhovhan@gmail.com]
Sent: Wednesday, October 28, 2015 9:15 AM

[Quoted text hidden]

[Quoted text hidden]

Mariam Hovhannisyan <mariamhovhan@gmail.com>
To: Kris Spickler <kspickler@structurlam.com>

Wed, Oct 28, 2015 at 10:12 AM

Hi Kris,

Sure that should be fine.

Mariam

[Quoted text hidden]

Kris Spickler <kspickler@structurlam.com>
To: Mariam Hovhannisyan <mariamhovhan@gmail.com>

Sun, Nov 1, 2015 at 4:08 PM

Marian,

Here are the prices for the materials including freight:

- Glulam columns (10.75" x 18") 30ft - \$1,389 EA

- Glulam columns (10.75" x 18") 20ft - \$956 EA
- Glulam Girders (6.75" x 40.5") ~30 ft long - \$1,962 EA
- CLT Panels (7 layers, no topping slab) 10 ft wide and spanning 20' – \$16.29 per SF

These numbers do not include steel, hardware, screws or any other connections. This is for material only shipped to site.

Kris Spickler | Heavy Timber Specialist

Heavy Timber Group - Structurlam Products LP

4120 Douglas Blvd. #306-502 | Granite Bay, CA 95746

Office: (916) 797-5588 | Mobile: (916) 759-9320

Email address: kspickler@structurlam.com

website: www.structurlam.com

CrossLam™ by Structurlam

From: Mariam Hovhannisyan [mailto:mariamhovhan@gmail.com]

Sent: Wednesday, October 28, 2015 9:15 AM

[Quoted text hidden]

[Quoted text hidden]

Mariam Hovhannisyan <mariamhovhan@gmail.com>

Tue, Nov 3, 2015 at 1:08 PM

To: Kris Spickler <kspickler@structurlam.com>

Thanks Kris! You rock!

I was asked some interesting questions about CLT by a superintendent the other day and I was wondering if you could help me answer some of them:

1. Are any fire sealants required at CLT joints as a flooring system for fire proofing in a mid rise application?
2. Does CLT expand when exposed to the weather during construction? Does it need temporary cover?
3. Does each panel come with ready made pick points for a crane? What are the hoisting accommodations?

Mariam

[Quoted text hidden]

Kris Spickler <kspickler@structurlam.com>

Tue, Nov 3, 2015 at 5:33 PM

To: Mariam Hovhannisyan <mariamhovhan@gmail.com>

Answers below.

From: Mariam Hovhannisyan [mailto:mariamhovhan@gmail.com]

Sent: Tuesday, November 3, 2015 1:09 PM
To: Kris Spickler <kspickler@structurlam.com>
Subject: Re: Master's Thesis

Thanks Kris! You rock!

I was asked some interesting questions about CLT by a superintendent the other day and I was wondering if you could help me answer some of them:

1. Are any fire sealants required at CLT joints as a flooring system for fire proofing in a mid rise application? It is a tight joint and covered with a spline, so no.
2. Does CLT expand when exposed to the weather during construction? Does it need temporary cover? No CLT is cross laminated and does not grow or shrink. It has an exterior glue, so no it won't delaminate. But if it is visual and you want to mitigate water staining you should protect it, cover, or sand off staining later.
3. Does each panel come with ready made pick points for a crane? What are the hoisting accommodations? Yes we use a Rampa system, see attached.

Mariam

[Quoted text hidden]



CrossLam Roof and floor installation 1-25-2014.pdf
4225K

Mariam Hovhannisyan <mariamhovhan@gmail.com>
To: Kris Spickler <kspickler@structurlam.com>

Tue, Nov 3, 2015 at 9:58 PM

Thanks Kris!

Mariam

[Quoted text hidden]



ANNING-JOHNSON COMPANY

14700 NE 95th St., Ste. 201
Redmond, WA 98052
425-885-1990
www.anningjohnson.com

DATE: 10/20/15

PROJECT: 7 Story Office Building

We are pleased to submit our bid for the work outlined below, according to plans, specifications and clarifications noted hereafter:

Architect: NA

Drawings and Date: NA

Addenda:

Spec Section (s) and Date: 078100 - APPLIED FIREPROOFING

BASE BUDGET

\$1,080,000

Clarifications

1. Base Budget includes the following:
 - **Fireproofing – 1A Type building Construction per IBC 2012.** Fireproofing is figured as standard density, high bond strength Cafco 300 HS. The floor decks are not figured to receive fireproofing (More than 4-1/2" of NW concrete).
2. Bid is based upon Anning-Johnson proposal and clarifications being incorporated into any sub contract. Fireproofing Checklist attached is included as part of this proposal.
3. Bid is based on GC providing adequate lay down area for pump/s and materials on ground floor with a slickline to access upper floors.
4. GC to provide ventilation and dehumidification to dry out installed fireproofing material.
5. Bid is based upon 1 mobilizations and a continuous operation.
6. Bid is based on using a 6,000 pound lift at high areas.
7. This proposal is good for 20 days only.
8. Fireproofing to be left "as sprayed" finish.

This proposal includes terms, conditions, clarifications and exclusions noted on attached sheets.

This proposal is made subject to your acceptance, by an authorized officer, within twenty (20) days from the date hereof.

This proposal is conditioned upon either the usage of the AGC/ASA/ASC "Standard Form Construction Subcontract", or a subcontract acceptable to us.

The information transmitted in this proposal supersedes any previous communication to the contrary. Further, we reserve the right to modify our price and terms at any time prior to the time for submitting your bid to the owner, to reflect adjustments resulting from our continuing review.

Respectfully submitted,

Ryan Marshall, NFCA DRI – SFRM | IFRM

Sr Estimator | Project Manager

Anning-Johnson Company

Office: 425.885.1990

Cell: 206.418.9025

CHECKLIST FOR SPRAYED FIREPROOFING

General Conditions:

1. Application is contingent on weather conditions consistent with manufacturer recommendations.
2. Steel surface to be free of dirt, oils, rust, scale and other misc. foreign debris. Prep, if required, to be by others.
3. **Clips, hangars (no longer than 6"), supports and sleeves shall be in place prior to fireproofing application. Ducts, piping, conduits, framing and other items that would interfere with the application shall not be in place.** Do not install vapor-retarding products over fireproofing until cured to 15% moisture or less.
4. **The work of other trades is assumed to be scheduled and completed in such a flow as to allow SFRM scope being performed to completion and in proper sequence. No trade stacking or out of sequence provisions are included in this bid.**
5. GC to keep floor (work area) clear of stock piled materials and other obstructions.
6. Schedule and contract shall be mutually agreeable.
7. **All concrete shall be completed prior to fireproofing the underside of floor deck per manufacturer's specification.**
8. **All Roofs shall be 100% complete prior to fireproofing the underside of roof deck and all work and traffic on the roof shall cease prior to fireproofing and for 30 days following completion of that work, per manufacturer's specifications.**
9. Floors will be scraped by our crews, leaving a discontinuous film of material.
10. GC shall accept and sign off completed areas regarding inspection and cleanup prior to allowing other work to commence in the areas.
11. Additions to work scope shall be authorized in writing prior to commencement of work. Mark up on changes shall be 10% overhead and 5% fee.
12. Payment terms: Progress billings, net 30 days 0% retention until work accepted.
13. Anning-Johnson Company standard one-year warranty is included.
14. Unless otherwise indicated, proposal is based on one mobilization to site. Additional mobilizations charged at \$2,200.00 each.
15. GC to provide twenty-four (24) hours written notice prior to performance of any back charge work, for clean-up, etc.
16. Anning-Johnson shall not be responsible for any consequential, direct, indirect, incidental damage or injuries due to toxic mold, bacteria and other such substances following the installation of our work. Protection of our work from damage including, but not limited to, weather and trade damage, shall not be the responsibility of Anning-Johnson Company.
17. Repairing or patching of damaged fireproofing is excluded, except as specifically noted in this proposal.

Requirements Provided by General Contractor:

1. Adequate areas for equipment and material storage including transport logistics (van at street level or other as may be required).
2. Lights, water, temporary weather protection, **ventilation, dehumidification** and heat as required.
3. Power- 3 Phase 480V/100A (pump), 220V/30A & 10 miscellaneous 110V/20A per pump set up.
4. Protection of existing conditions.
5. Protection of in-place fireproofing.
6. OSHA required safety railings and devices other than individual PPE.
7. Hoisting and scaffolding.
8. Sanitary facilities.
9. Dumpster.

Exclusions:

1. Weather protection, heat and ventilation.
2. Protection of existing and in-place work and conditions.
3. Fireproofing precast and slab edge connections, seismic braces, wall and floor angles, embeds or lintels.
4. Protection of metal decks not receiving fireproofing except where noted above.
5. Debris container. Anning-Johnson will remove fireproofing debris to contractor provided dumpster.
6. Testing and inspection of spray applied fireproofing material.
7. Removal of fireproofing for installation of other trades work.
8. Intumescent Fireproofing IFRM.
9. Bond, permits and Washington state sales tax.
10. Design & As-builts.
11. Lath & Bond of primed steel scheduled to receive SFRM (members need to be unprimed with approved primer).



Mariam Hovhannisyan <mariamhovhan@gmail.com>

University of Washington Thesis - Estimate Request

5 messages

Mariam Hovhannisyan <mariamhovhan@gmail.com>

Mon, Oct 19, 2015 at 1:23 PM

To: tomc@sfcs.com

Hi,

My name is Mariam and I am a student at the UW working on my Master's in Architecture Thesis. I am comparing a structural steel office building to a mass timber office building and was hoping that you could provide me with some quick pricing metrics to use. I know that it's a very busy market right now, but even a ROM would be a great help!

About the Project

It is a typical, 7 story open plan office building to be located in downtown Seattle's South Lake Union district (on Fairview and Republican - there is a current project under construction there). The grid for the structural steel option is roughly 30' x 30' with 2 levels of concrete parking below. The grid for the mass timber option is roughly 20' x 30' with CLT spanning in the 20' direction.

Pricing I need and applicable assumptions:

Please include supply & install, steel reinforcing, form work, embeds and any equipment (not including a tower crane) for the following scopes of work - current \$:

1. Concrete spread footing - **\$/CY including mark-ups**
2. Continuous wall footings - **\$/CY including mark-ups**
3. Shear Wall Footings = **\$/CY including mark-ups**
4. 12" Shear core wall (centralized) = **\$/CY including mark-ups**
5. 3" concrete topping on metal deck (or composite assembly) = **115,155 SF**
6. **How long do you anticipate the concrete work to take?**
7. **Are there any lead times to be concerned about?**

See attached documents for schematic structural plans.

Thank you & hope to hear from you soon,

Mariam

**Structural Plan - Thesis.pdf**

389K

Thomas Cook <tomc@sfcs.com>

Mon, Oct 19, 2015 at 1:39 PM

To: Mariam Hovhannisyan <mariamhovhan@gmail.com>

Miriam,

To budget these out.

I use SF in that area for budgeting.

I would use \$50.00 Per SF of Post Tension deck only.

If it has a matt slab footing at Parking level add 10 dollars a foot per 1 foot of height in matt slab footing.

Crane pads run depending on crane size form \$25,000.00 to \$45,000.00

I always do my price per yard for entire job..

For example this job should be around \$675.00 total per yard.

The above cal'c are not for your pan deck, i do this separate.

Those will be around \$6.75 per Deck First Deck.

Add 10% each deck after.

Also these are only double check numbers or for budgetarty purposes.

With computer estimating progams I can do this job with actuals in a day.

Hope this helps.

Scheduling and Plans here: ***Plans***

Scheduling of your project. Please call [253-531-6745](tel:253-531-6745)

Thomas J Cook

Project Manger /Estimator

Certified

PTI LEVEL 2 Unbonded PT Inspector

Cell: [\(253\) 686-9625](tel:253-686-9625)

Email: [Tom's Email](#)

Website: [Foundation Specialists LLC Website](#)

Address:

3922 112th St E

Tacoma WA 98446

Corporate Office [\(253\) 531-6745](tel:253-531-6745)

Corporate Fax [\(253\) 531-5797](tel:253-531-5797)

This e-mail and any files transmitted with it are private and confidential and are solely for the use of the addressee. It may contain material which is legally privileged. If you are not the addressee or the person responsible for delivering to the addressee, be advised that you have received this e-mail in error and that any use of it is strictly prohibited.

From: Mariam Hovhannisyan [mailto:mariamhovhan@gmail.com]
Sent: Monday, October 19, 2015 1:23 PM
To: Thomas Cook
Subject: University of Washington Thesis - Estimate Request

[Quoted text hidden]

Mariam Hovhannisyan <mariamhovhan@gmail.com>
To: Thomas Cook <tomc@fsfcs.com>

Mon, Oct 19, 2015 at 1:42 PM

Thanks Thomas!

That's a great help; if you have some availability to do actual numbers I would be thrilled; otherwise I can stick with these.

Thanks again!

Mariam

[Quoted text hidden]

Thomas Cook <tomc@fsfcs.com>
To: Mariam Hovhannisyan <mariamhovhan@gmail.com>

Mon, Oct 19, 2015 at 1:48 PM

Mariam,

That is all I would use with out structural drawings.

Anything else would put me in the position of backing up my numbers.

And you always need a way to back out until you get the structurals.

Some Structural Engineers can double the cost by over engineering,.

Thanks.

Scheduling and Plans here: ***Plans***

Scheduling of your project. Please call [253-531-6745](tel:253-531-6745)

Thomas J Cook

Project Manger /Estimator

Certified

PTI LEVEL 2 Unbonded PT Inspector

Cell: [\(253\) 686-9625](tel:253-686-9625)

Email: [Tom's Email](#)

Website: [Foundation Specialists LLC Website](#)

Address:

3922 112th St E

Tacoma WA 98446

Corporate Office (253) 531-6745

Corporate Fax (253) 531-5797

This e-mail and any files transmitted with it are private and confidential and are solely for the use of the addressee. It may contain material which is legally privileged. If you are not the addressee or the person responsible for delivering to the addressee, be advised that you have received this e-mail in error and that any use of it is strictly prohibited.

From: Mariam Hovhannisyan [mailto:mariamhovhan@gmail.com]
Sent: Monday, October 19, 2015 1:43 PM
To: Thomas Cook
Subject: Re: University of Washington Thesis - Estimate Request

[Quoted text hidden]

Mariam Hovhannisyan <mariamhovhan@gmail.com>
To: Thomas Cook <tomc@fsfcs.com>

Mon, Oct 19, 2015 at 1:50 PM

Understood, thanks for your help!

Mariam

[Quoted text hidden]



Mariam Hovhannisyan <mariamhovhan@gmail.com>

University of Washington Thesis - Estimate Request

7 messages

Mariam Hovhannisyan <mariamhovhan@gmail.com>

Mon, Oct 19, 2015 at 2:22 PM

To: georgeb@cgius.net

Hi,

My name is Mariam and I am a student at the UW working on my Master's in Architecture Thesis. I am comparing a structural steel office building to a mass timber office building and was hoping that you could provide me with some quick pricing metrics to use. I know that it's a very busy market right now, but even a ROM would be a great help!

About the Project

It is a typical, 7 story open plan office building to be located in downtown Seattle's South Lake Union district (on Fairview and Republican - there is a current project under construction there). The grid for the structural steel option is roughly 30' x 30' with 2 levels of concrete parking below. The grid for the mass timber option is roughly 20' x 30' with CLT spanning in the 20' direction.

Pricing I need and applicable assumptions:

Please include supply & install, equipment, mark-ups for the following - current \$:

1. Spray on fireproofing at columns (W14x176)- **1104 LF**
2. Spray on fireproofing at girders (W18x60) - **2923 LF**
3. Spray on fireproofing at beams (W18x35)- **13868 LF**

See attached documents for schematic structural plans.

Thank you & hope to hear from you soon,

Mariam

**Structural Plan - Thesis.pdf**

389K

George Bruce <georgeb@cgius.net>

Mon, Oct 19, 2015 at 3:34 PM

To: Mariam Hovhannisyan <mariamhovhan@gmail.com>

Mariam:

Need a little more information, like hourly rating of primary and secondary structural members. 1-hour, 2-hour or 3-hour?

Thanks,

From: Mariam Hovhannisyan [mailto:mariamhovhan@gmail.com]

Sent: Monday, October 19, 2015 2:23 PM
To: George Bruce
Subject: University of Washington Thesis - Estimate Request

[Quoted text hidden]

George Bruce <georgeb@cgius.net>
To: Mariam Hovhannisyan <mariamhovhan@gmail.com>

Mon, Oct 19, 2015 at 3:38 PM

Also, if there is less than 2.5" of concrete cover over pan decking, then the deck also needs to be fireproofed.

From: Mariam Hovhannisyan [mailto:mariamhovhan@gmail.com]
Sent: Monday, October 19, 2015 2:23 PM
To: George Bruce
Subject: University of Washington Thesis - Estimate Request

Hi,

[Quoted text hidden]

About the Project

[Quoted text hidden]

[Quoted text hidden]

[Quoted text hidden]

George Bruce <georgeb@cgius.net>
To: Mariam Hovhannisyan <mariamhovhan@gmail.com>

Mon, Oct 19, 2015 at 3:57 PM

Mariam:

It looks like we have 5 floor plates approximately 116' X 187' for a total area subject to fireproofing of 108,460 SF. If there is pan deck that needs to be sprayed, the surface area is approximately 152,929 SF. As previously mentioned, concrete floors have a minimum thickness requirement per rated hour for spray not to be required. This makes a significant difference in material and labor. We will use your LF takeoffs and look forward to your clarifications.

Thanks,

From: Mariam Hovhannisyan [mailto:mariamhovhan@gmail.com]
Sent: Monday, October 19, 2015 2:23 PM
To: George Bruce
Subject: University of Washington Thesis - Estimate Request

Hi,

[Quoted text hidden]

About the Project

[Quoted text hidden]

[Quoted text hidden]

[Quoted text hidden]

Mariam Hovhannisyan <mariamhovhan@gmail.com>
To: George Bruce <georgeb@cgius.net>

Mon, Oct 19, 2015 at 6:57 PM

Hi George!

Thank you for your response! Let's assume 2 hour rating. There is 3" of concrete over the pan decking so I don't believe that fireproofing will be required there.

Thanks again!

Mariam

[Quoted text hidden]

George Bruce <georgeb@cgius.net>
To: Mariam Hovhannisyan <mariamhovhan@gmail.com>

Tue, Oct 20, 2015 at 7:36 AM

Mariam:

If we were to bid the project under current market conditions, we estimate it would be a \$185,490 project.

Thanks,

From: Mariam Hovhannisyan [mailto:mariamhovhan@gmail.com]
Sent: Monday, October 19, 2015 6:57 PM
To: George Bruce
Subject: Re: University of Washington Thesis - Estimate Request

[Quoted text hidden]

Mariam Hovhannisyan <mariamhovhan@gmail.com>
To: George Bruce <georgeb@cgius.net>

Tue, Oct 20, 2015 at 8:53 AM

Thanks so much George!

Mariam

[Quoted text hidden]



Mariam Hovhannisyan <mariamhovhan@gmail.com>

University of Washington Thesis - Estimate Request

6 messages

Mariam Hovhannisyan <mariamhovhan@gmail.com>

Mon, Oct 19, 2015 at 2:21 PM

To: cdunbar@ansonindustries.com

Hi,

My name is Mariam and I am a student at the UW working on my Master's in Architecture Thesis. I am comparing a structural steel office building to a mass timber office building and was hoping that you could provide me with some quick pricing metrics to use. I know that it's a very busy market right now, but even a ROM would be a great help!

About the Project

It is a typical, 7 story open plan office building to be located in downtown Seattle's South Lake Union district (on Fairview and Republican - there is a current project under construction there). The grid for the structural steel option is roughly 30' x 30' with 2 levels of concrete parking below. The grid for the mass timber option is roughly 20' x 30' with CLT spanning in the 20' direction.

Pricing I need and applicable assumptions:

Please include supply & install, equipment, mark-ups for the following - current \$:

1. Spray on fireproofing at columns (W14x176)- **1104 LF**
2. Spray on fireproofing at girders (W18x60) - **2923 LF**
3. Spray on fireproofing at beams (W18x35)- **13868 LF**

See attached documents for schematic structural plans.

Thank you & hope to hear from you soon,

Mariam

**Structural Plan - Thesis.pdf**

389K

Curtis Dunbar <CDunbar@anningjohnson.com>

Mon, Oct 19, 2015 at 3:55 PM

To: Mariam Hovhannisyan <mariamhovhan@gmail.com>, Ryan Marshall <rmarshall@anningjohnson.com>

Cc: Derek Marino <DMarino@anningjohnson.com>, Luke Prigg <lprigg@anningjohnson.com>

Mariam,

Good luck with your project. Yes, things are really busy in the industry.

I have asked one of my Fireproofing Estimators, Ryan Marshall, to shoot you a rough budget for the fireproofing you requested. He will contact you.

Our work is mostly in the commercial realm with primary scopes of work including: fireproofing of struct steel, metal studs, drywall & finish, lath & plaster. Let us know if you need anything else or any of these scopes.

Thanks and again good luck,

Curtis



CURTIS L. DUNBAR | **CHIEF ESTIMATOR – PROJECT EXECUTIVE**

ANNING-JOHNSON COMPANY | 14700 NE 95TH ST #201 REDMOND, WA 98052

O: [425.885.1990](tel:425.885.1990) | D: [425-284-6826](tel:425-284-6826) | M: [425-894-0064](tel:425-894-0064)

cdunbar@anningjohnson.com

Atlanta | Chicago | Las Vegas | Los Angeles | Portland | San Francisco | **Seattle** | Washington DC

From: Mariam Hovhannisyan [mailto:mariamhovhan@gmail.com]

Sent: Monday, October 19, 2015 2:22 PM

To: Curtis Dunbar <CDunbar@anningjohnson.com>

Subject: University of Washington Thesis - Estimate Request

[Quoted text hidden]

Disclaimer

The information contained in this communication from the sender is confidential. It is intended solely for use by the recipient and others authorized to receive it. If you are not the recipient, you are hereby notified that any disclosure, copying, distribution or taking action in relation of the contents of this information is strictly prohibited and may be unlawful.

This email has been scanned for viruses and malware, and may have been automatically archived by **Mimecast Ltd**, an innovator in Software as a Service (SaaS) for business. Providing a **safer** and **more useful** place for your human generated data. Specializing in; Security, archiving and compliance. To find out more [Click Here](#).

Luke Prigg <lprigg@anningjohnson.com>
To: Mariam Hovhannisyan <mariamhovhan@gmail.com>

Mon, Oct 19, 2015 at 4:58 PM

Hi Mariam,

I just wanted to say hello and send a quick thank you for reaching out to us. It isn't often that we are able to provide this type of input. As Curtis said below, we are happy to help in any way that we can. I also wanted to let you know that we will be at the career fair November 5th at Gould Hall. If you are available it would be great to meet you in person. Take care and best of luck on the thesis!

Sincerely,



LUKE PRIGG | VICE PRESIDENT / DISTRICT MANAGER
ANNING-JOHNSON COMPANY | 14700 NE 95TH ST #201 REDMOND, WA 98052
O: 425.885.1990 | D: 425.284.6830 | M: 206.861.6781

Atlanta | Chicago | Las Vegas | Los Angeles | Portland | San Francisco | **Seattle** | Washington DC

From: Curtis Dunbar
Sent: Monday, October 19, 2015 3:56 PM
To: Mariam Hovhannisyan <mariamhovhan@gmail.com>; Ryan Marshall <rmarshal@anningjohnson.com>
Cc: Derek Marino <DMarino@anningjohnson.com>; Luke Prigg <lprigg@anningjohnson.com>
Subject: RE: University of Washington Thesis - Estimate Request

[Quoted text hidden]

[Quoted text hidden]

Mariam Hovhannisyan <mariamhovhan@gmail.com>
To: Luke Prigg <lprigg@anningjohnson.com>

Mon, Oct 19, 2015 at 7:05 PM

Thanks for all the help! I would love to meet you!

Mariam

[Quoted text hidden]

Ryan Marshall <rmarshal@anningjohnson.com>
To: Mariam Hovhannisyan <mariamhovhan@gmail.com>
Cc: Derek Marino <DMarino@anningjohnson.com>, Luke Prigg <lprigg@anningjohnson.com>, Curtis Dunbar <CDunbar@anningjohnson.com>

Tue, Oct 20, 2015 at 5:57 PM

Hi Mariam,

Attached, I put the pricing on a form that we would typically use to send budget info to the General Contractors.

There were a few assumptions that I made, the biggest ones being it is a 1A type building and that there is enough concrete on the floors that the decks would not require fireproofing. Feel free to let me know if you have any questions.

Thank you, Ryan



RYAN MARSHALL | SR ESTIMATOR/PROJECT MANAGER
ANNING-JOHNSON COMPANY | 14700 NE 95TH ST #201 **REDMOND**, WA 98052
O: 425.885.1990 | EXT: 452 | C: 206.418.9025 | F: 425.869.5824

Atlanta | Chicago | Las Vegas | Los Angeles | Portland | San Francisco | **Seattle** | Washington DC

From: Curtis Dunbar
Sent: Monday, October 19, 2015 3:56 PM
To: Mariam Hovhannisyan; Ryan Marshall
Cc: Derek Marino; Luke Prigg
Subject: RE: University of Washington Thesis - Estimate Request

[Quoted text hidden]

[Quoted text hidden]

 **AJ Fireproofing Budget - 7 Story Office Building.pdf**
233K

Mariam Hovhannisyan <mariamhovhan@gmail.com>
To: Ryan Marshall <rmarshal@anningjohnson.com>

Wed, Oct 21, 2015 at 9:39 PM

Thanks Ryan; this is a huge help!!!

Mariam

[Quoted text hidden]



PRODUCTS REPLACEMENTS SYSTEMS MANUALS SPECS GUIDE COSTS SURFACES

Home | Products | Raised Floor Panels | Raised Floor Kits | TATE® Refurbished Raised Floor System

Search



RELATED PRODUCTS

Check items to add to the cart or [select all](#)

- 

RISE Access Floor Cleaner - Case
 Regular Price: ~~\$ 94.99~~
Special Price: \$ 86.25
[Add to Wishlist](#)
- 

The Guide to Access Floor Maintenance
\$ 12.95 each
[Add to Wishlist](#)
- 

Standard 4 Inch Panel Lifter
\$ 38.50 each
[Add to Wishlist](#)



TATE® Refurbished Raised Floor System

Be the first to review this product

\$ 10.80
per square foot

[Add to Wishlist](#)
[Add to Compare](#)

Quick Overview

Previously owned TATE® concrete filled access floor kit with new high



Double click on above image to view full picture



More Views



pressure laminate surface and bolted stringer understructure. Color: ST61 Grey Starlite. Includes 24" x 24" panels, adjustable pedestals, steel stringers, fasteners, and pedestal adhesive. Pedestal bases will have residual adhesive from previous installation. Sold by the square foot in 4' increments. Available in heights from 6" - 24" FFH. Please select required height.

Additional Information

Model	LSK
Height (in inches)	6" - 24"
Notes	3 - 4 weeks fabrication

Height of Raised Floor *

- 6" Finished Floor Height **\$ 10.80**
- 12" Finished Floor Height **\$ 10.80**
- 18" Finished Floor Height **\$ 11.80**
- 24" Finished Floor Height **\$ 12.80**

* Required Fields

\$ 10.80
per square foot

Qty:

Add to Cart

Product Description

Several months ago, a large customer of ours moved to a new facility and we acquired their floor system. They always took great care of their raised floor and we were happy to remove it for them.

This pre-owned access floor has been freshly laminated and is available by the square foot, in 4' increments. This is a high grade concrete filled steel panel system. The color of the high pressure laminate is Grey Starlite. This attractive finish has always been popular on raised floors because of its low maintenance and static dissipative properties. The black edge trim is not a separate piece of plastic, it is integral to the laminate.

This TATE® floor system (CSF1250) is a very high-quality raised floor and is easy to install. The way the components fit together makes installation easier for the first timer, or for the most experienced. The system is constructed in such a way that the panels nest inside and are locked into a steel grid, creating an extremely rigid system. The grid for this system is bolted, whereby the crosspieces (stringers) fasten to the pedestal heads. The panels are 24" x 24", the standard for raised floors. These panels are rated at 1250 lbs. per square inch.





This price includes the adhesive that holds the bases to the sub-floor, the pedestal assemblies consisting of an all steel base and adjustable head (1" up and 1" down), the 2' cross pieces (they form a grid) that go from pedestal head to pedestal head, the screw fasteners that fasten the stringers to the pedestal heads, and the panels (which nest inside the grid).

Minimum Purchase of 150 Square Feet. Price is per square foot. Please indicate height required. Freight and installation not included. [Installation instructions](#) are online for your convenience. The price shown is for orders over 100 panels (400 sf). Please contact us for a quote on orders under 400 square feet.

This floor system is manufactured by TATE®.

[Click here to get a quick quote on everything you need for your floor.](#)

You may also be interested in the following product(s)

 <p>Infinity Air Grate Max 66% Perforated Panel fits steel - Free Levelers</p> <p>Regular Price: \$ 211.48 Special Price: \$ 204.73</p> <p>★★★★★ 1 Review(s) Add Your Review</p>	 <p>KoldLok® Integral 1010 - Case</p> <p>Regular Price: \$ 790.00 Special Price: \$ 632.00</p>	 <p>PolarDAM™ Foam Sample</p> <p>\$ 19.50 each</p>	 <p>PlenaForm® Raised Floor Baffle Kit</p> <p>\$ 1,392.00 each</p>
--	---	--	---

ABOUT



For over 30 years, Access Floor Systems has been providing durable, cost-effective and energy-efficient raised floor systems. [Read More](#)

CONTACT US

HELP

- [Quick Raised Floor Quote](#)
- [Replacement Panel Quote](#)
- [Cable Tray Estimator](#)
- [Budget Calculator](#)
- [System Selector Guide](#)
- [Installation Manual](#)
- [Maintenance Guide](#)
- [Color Selection Chart](#)

ACCESSORIES

- [RISE Access Floor Cleaner](#)
- [Suction Cup Panel Lifters](#)
- [Raised Floor Grommets](#)
- [Blanking Panels](#)
- [Underfloor Cable Trays](#)
- [Trim Materials for Panels](#)
- [Carpet Tile](#)
- [Containment](#)

Name*	Email*
Phone Number	
Message	
<input type="submit" value="submit"/>	

[About Us](#) | [Customer Service](#) | [Site Map](#) | [Search Terms](#) | [Advanced Search](#) | [Contact Us](#)

Copyright © 1994 - 2015 Access Floor Systems.com, Inc. All rights reserved.





Mariam Hovhannisyan <mariamhovhan@gmail.com>

University of Washington Thesis - Estimate Request

9 messages

Mariam Hovhannisyan <mariamhovhan@gmail.com>

Mon, Oct 19, 2015 at 2:04 PM

To: tony@storyacoustics.com

Hi,

My name is Mariam and I am a student at the UW working on my Master's in Architecture Thesis. I am comparing a structural steel office building to a mass timber office building and was hoping that you could provide me with some quick pricing metrics to use. I know that it's a very busy market right now, but even a ROM would be a great help!

About the Project

It is a typical, 7 story open plan office building to be located in downtown Seattle's South Lake Union district (on Fairview and Republican - there is a current project under construction there). The grid for the structural steel option is roughly 30' x 30' with 2 levels of concrete parking below. The grid for the mass timber option is roughly 20' x 30' with CLT spanning in the 20' direction.

Pricing I need and applicable assumptions:

Please include install, install of connections, mark-ups for the following - current \$:

1. 2x2 ceiling grid (assume typical white) hung ~2' from above- **\$/SF**
2. **Are there any lead times on this item?**

See attached documents for schematic structural plans.

Thank you & hope to hear from you soon,

Mariam

**Structural Plan - Thesis.pdf**

389K

Tony Wood <tony@storyacoustics.com>

Mon, Oct 19, 2015 at 2:23 PM

Reply-To: tony@storyacoustics.com

To: Mariam Hovhannisyan <mariamhovhan@gmail.com>

How did you get my info ?

From: Mariam Hovhannisyan [mailto:mariamhovhan@gmail.com]**Sent:** Monday, October 19, 2015 2:05 PM**To:** tony@storyacoustics.com**Subject:** University of Washington Thesis - Estimate Request

[Quoted text hidden]

Mariam Hovhannisyan <mariamhovhan@gmail.com>

Mon, Oct 19, 2015 at 2:25 PM

To: tony@storyacoustics.com

Hi Tony!

I also work for Rafn and they had your contact information on their database. Let me know if you need any more information.

Mariam

[Quoted text hidden]

Tony Wood <tony@storyacoustics.com>
Reply-To: tony@storyacoustics.com
To: Mariam Hovhannisyan <mariamhovhan@gmail.com>

Mon, Oct 19, 2015 at 2:40 PM

Gotcha . Tile comes in about 20 types and fissures that are typical white . It can range from \$ 3.00 per sf to \$ 7.00 /sf based on product (\$ 3 - \$ 4.50 will cover most products but not all) . Standard lead times are usually 2-4 weeks .

Thanks

Tony Wood

From: Mariam Hovhannisyan [mailto:mariamhovhan@gmail.com]
Sent: Monday, October 19, 2015 2:25 PM
To: tony@storyacoustics.com
Subject: Re: University of Washington Thesis - Estimate Request

[Quoted text hidden]

Mariam Hovhannisyan <mariamhovhan@gmail.com>
To: tony@storyacoustics.com

Mon, Oct 19, 2015 at 2:49 PM

Thanks for your help Tony! It's greatly appreciated, especially given how busy everyone is these days!

Could you also provide me with some information on how long you think it would take to install?

Thanks again!

Mariam

[Quoted text hidden]

Tony Wood <tony@storyacoustics.com>
Reply-To: tony@storyacoustics.com
To: Mariam Hovhannisyan <mariamhovhan@gmail.com>

Mon, Oct 19, 2015 at 2:54 PM

What is the total SF of acoustical ceiling ?

From: Mariam Hovhannisyan [mailto:mariamhovhan@gmail.com]
Sent: Monday, October 19, 2015 2:49 PM

[Quoted text hidden]

[Quoted text hidden]

Mariam Hovhannisyan <mariamhovhan@gmail.com>
To: tony@storyacoustics.com

Mon, Oct 19, 2015 at 2:57 PM

It would be 115,155sf total.

Mariam

[Quoted text hidden]

Tony Wood <tony@storyacoustics.com>
Reply-To: tony@storyacoustics.com
To: Mariam Hovhannisyan <mariamhovhan@gmail.com>

Mon, Oct 19, 2015 at 3:10 PM

Figure 500 sf a day for grid and 800 sf a day for tile

From: Mariam Hovhannisyan [mailto:mariamhovhan@gmail.com]
Sent: Monday, October 19, 2015 2:58 PM
To: tony@storyacoustics.com
Subject: RE: University of Washington Thesis - Estimate Request

[Quoted text hidden]

Mariam Hovhannisyan <mariamhovhan@gmail.com>
To: tony@storyacoustics.com

Mon, Oct 19, 2015 at 3:09 PM

Ok, great!!

Thanks so much,

Mariam

[Quoted text hidden]



Mariam Hovhannisyan <mariamhovhan@gmail.com>

UW Thesis - Pricing Request

3 messages

Mariam Hovhannisyan <mariamhovhan@gmail.com>

Fri, Nov 6, 2015 at 7:36 AM

To: dave@legacy-us.com

Hi,

My name is Mariam and I am a student at the UW working on my Master's in Architecture Thesis. I am comparing a structural steel office building to a mass timber office building and was hoping that you could provide me with some quick pricing metrics to use. I know that it's a very busy market right now, but even a ROM would be a great help!

About the Project

It is a typical, 7 story open plan office building to be located in downtown Seattle's South Lake Union district (on Fairview and Republican - there is a current project under construction there). The grid for the structural steel option is roughly 30' x 30' with 2 levels of concrete parking below. The grid for the mass timber option is roughly 20' x 30' with CLT spanning in the 20' direction.

Pricing I need and applicable assumptions:

Please include supply of the following - current \$ (include labor, material & equip if req'd):

1. Raised flooring system (1' raised with carpet tile) - **\$/SF**
2. Typical carpet tile system on SOMD or wood - **\$/SF**
3. **How long would installation take for these different systems (assume 115,155 SF total)?**

See attached documents for schematic structural plans.

Thank you & hope to hear from you soon,

Mariam

**Structural Plan - Thesis.pdf**

389K

Dave Spannaus <dave@legacy-us.com>

Fri, Nov 6, 2015 at 10:27 AM

To: Mariam Hovhannisyan <mariamhovhan@gmail.com>

Mariam,

Pricing for carpet tile can range from \$3.00/sf to over \$5.00/sf depending on the styles chosen.

I do not know what a raised flooring system would cost as that is not something we provide.

As far as the schedule goes, I would figure 4-5 weeks for the installation duration and complexity of the installation.

Also, what do CLT and SOMD stand for?

Dave

From: Mariam Hovhannisyan [mailto:mariamhovhan@gmail.com]
Sent: Friday, November 06, 2015 7:37 AM
To: Dave Spannaus
Subject: UW Thesis - Pricing Request

[Quoted text hidden]

Mariam Hovhannisyan <mariamhovhan@gmail.com>
To: Dave Spannaus <dave@legacy-us.com>

Fri, Nov 6, 2015 at 11:32 AM

Thanks Dave!

Would you happen to know who might provide some pricing for a raised flooring system that you could direct me to?

SOMD - slab on metal deck
CLT - Cross laminated timber (wood flooring)

Sorry about the abbreviations! I've been using the for my own spreadsheets and have forgotten to write things out.

Thanks again,

Marian

[Quoted text hidden]



Mariam Hovhannisyan <mariamhovhan@gmail.com>

University of Washington Thesis - Estimate Request

6 messages

Mariam Hovhannisyan <mariamhovhan@gmail.com>

Fri, Oct 23, 2015 at 9:15 AM

To: UlisesM@ketchikandrywall.com, billc@ketchikandrywall.com

Hi,

My name is Mariam and I am a student at the UW working on my Master's in Architecture Thesis. I am comparing a structural steel office building to a mass timber office building and was hoping that you could provide me with some quick pricing metrics to use. I know that it's a very busy market right now, but even a ROM would be a great help!

About the Project

It is a typical, 7 story open plan office building to be located in downtown Seattle's South Lake Union district (on Fairview and Republican - there is a current project under construction there). The grid for the structural steel option is roughly 30' x 30' with 2 levels of concrete parking below. The grid for the mass timber option is roughly 20' x 30' with CLT spanning in the 20' direction.

Pricing I need and applicable assumptions:

Please include install, install of connections, mark-ups for the following - current \$:

1. Gypsum Wall board (to go over steel columns)- **\$/SF**
2. Painting - **\$/SF**
3. Metal Framing (excluding GWB) - **\$/SF or \$/LF wall**

See attached documents for schematic structural plans.

Thank you & hope to hear from you soon!

Mariam

**Structural Plan - Thesis.pdf**

389K

Ulises Morales <ulisesm@ketchikandrywall.com>

Fri, Oct 23, 2015 at 9:45 AM

To: Mariam Hovhannisyan <mariamhovhan@gmail.com>, Bill Cowin <billc@ketchikandrywall.com>

Ulises Morales

Ketchikan Drywall Services, Inc

Estimator / Project Manager

O: 425-488-7625

C: 206-639-7177

From: Mariam Hovhannisyan [mailto:mariamhovhan@gmail.com]
Sent: Friday, October 23, 2015 9:16 AM
To: Ulises Morales <ulisesm@ketchikandrywall.com>; Bill Cowin <billc@ketchikandrywall.com>
Subject: University of Washington Thesis - Estimate Request

Hi,

My name is Mariam and I am a student at the UW working on my Master's in Architecture Thesis. I am comparing a structural steel office building to a mass timber office building and was hoping that you could provide me with some quick pricing metrics to use. I know that it's a very busy market right now, but even a ROM would be a great help!

About the Project

It is a typical, 7 story open plan office building to be located in downtown Seattle's South Lake Union district (on Fairview and Republican - there is a current project under construction there). The grid for the structural steel option is roughly 30' x 30' with 2 levels of concrete parking below. The grid for the mass timber option is roughly 20' x 30' with CLT spanning in the 20' direction.

Pricing I need and applicable assumptions:

Please include install, install of connections, mark-ups for the following - current \$:

1. Gypsum Wall board (to go over steel columns)- **\$/SF- \$22 per LF.. This is to wrap the columns 2 layer of drywall similar to UL design X528**

http://database.ul.com/cgi-bin/XYV/template/LISEXT/1FRAME/showpage.html?name=BXUV.X528&ccnshorttitle=Fire+Resistance+Ratings+-+ANSI/UL+263&objid=1074331727&cfgid=1073741824&version=versionless&parent_id=1073984818&sequence=1

2. Painting - **\$/SF**
3. Metal Framing (excluding GWB) - **\$/SF or \$/LF wall. \$18.00 LF. This is for a wall up to 10' tall, 20gauge framed wall.**

See attached documents for schematic structural plans.

Thank you & hope to hear from you soon!

Mariam

Mariam Hovhannisyan <mariamhovhan@gmail.com>
To: Ulises Morales <ulisesm@ketchikandrywall.com>

Fri, Oct 23, 2015 at 9:51 AM

Thanks Ulises! This is a huge help!!

Mariam

[Quoted text hidden]

Mariam Hovhannisyan <mariamhovhan@gmail.com>
To: Ulises Morales <ulisesm@ketchikandrywall.com>

Tue, Oct 27, 2015 at 7:22 PM

Hi Ulises!

I wonder if I might be able to ask you for one more price? Could you give me a rough SF price for a dropped ceiling soffit? I just need a budgetary ROM number that includes the GWB, dropped light gauge metal stud framing and

installation of the assembly.

Thanks again and I promise this is the last one!

Mariam

[Quoted text hidden]

Ulises Morales <ulisesm@ketchikandrywall.com>
To: Mariam Hovhannisyan <mariamhovhan@gmail.com>

Wed, Oct 28, 2015 at 7:36 AM

\$5.50sf

Ulises Morales

Ketchikan Drywall Services, Inc

Estimator / Project Manager

O: 425-488-7625

C: 206-639-7177

From: Mariam Hovhannisyan [mailto:mariamhovhan@gmail.com]

Sent: Tuesday, October 27, 2015 7:22 PM

To: Ulises Morales <ulisesm@ketchikandrywall.com>

Subject: Re: University of Washington Thesis - Estimate Request

[Quoted text hidden]

Mariam Hovhannisyan <mariamhovhan@gmail.com>
To: Ulises Morales <ulisesm@ketchikandrywall.com>

Wed, Oct 28, 2015 at 9:11 AM

Thanks Ulises!

[Quoted text hidden]



Mariam Hovhannisyan <mariamhovhan@gmail.com>

University of Washington - Thesis

2 messages

Mariam Hovhannisyan <mariamhovhan@gmail.com>

Mon, Nov 23, 2015 at 8:22 AM

To: justin@paintsmith.com, bob@paintsmith.com

Hi!

My name is Mariam and I am a student at the UW working on my Master's in Architecture Thesis. I am comparing a structural steel office building to a mass timber office building and was hoping that you could provide me with some quick pricing metrics to use. I know that it's a very busy market right now, but even a ROM would be a great help!

About the Project

It is a typical, 7 story open plan office building to be located in downtown Seattle's South Lake Union district (on Fairview and Republican - there is a current project under construction there). The grid for the structural steel option is roughly 30' x 30' with 2 levels of concrete parking below. The grid for the mass timber option is roughly 20' x 30' with CLT spanning in the 20' direction.

Pricing I need and applicable assumptions:

Supply & Install

Interior wall paint - \$/SF

Interior wood paint/finish (assume satin semi clear coat - white) - \$/SF

Thanks!

Justin Smith <justin@paintsmith.com>

Tue, Nov 24, 2015 at 7:13 AM

To: Mariam Hovhannisyan <mariamhovhan@gmail.com>

Hi,

Walls \$.80/sf of actual wall surface

Wood stained and clearcoated \$3.50/sf of actual exposed wood

Good luck,

Justin Smith

PaintSmith Co

206 661 5556

From: Mariam Hovhannisyan [mailto:mariamhovhan@gmail.com]

Sent: Monday, November 23, 2015 8:22 AM

To: Justin Smith <justin@paintsmith.com>; Bob Smith <bob@paintsmith.com>

Subject: University of Washington - Thesis

[Quoted text hidden]



Mariam Hovhannisyan <mariamhovhan@gmail.com>

University of Washington - Thesis

5 messages

Mariam Hovhannisyan <mariamhovhan@gmail.com>

Mon, Nov 23, 2015 at 8:16 AM

To: info@soundpaintingsolutions.com

Hi!

My name is Mariam and I am a student at the UW working on my Master's in Architecture Thesis. I am comparing a structural steel office building to a mass timber office building and was hoping that you could provide me with some quick pricing metrics to use. I know that it's a very busy market right now, but even a ROM would be a great help!

About the Project

It is a typical, 7 story open plan office building to be located in downtown Seattle's South Lake Union district (on Fairview and Republican - there is a current project under construction there). The grid for the structural steel option is roughly 30' x 30' with 2 levels of concrete parking below. The grid for the mass timber option is roughly 20' x 30' with CLT spanning in the 20' direction.

Pricing I need and applicable assumptions:

Supply & Install

Interior wall paint - \$/SF

Interior wood paint/finish (assume satin semi clear coat - white) - \$/SF

Thanks!

Mariam

Jeff Dupont <jeff@soundpaintingsolutions.com>

Mon, Nov 23, 2015 at 3:14 PM

To: Mariam Hovhannisyan <mariamhovhan@gmail.com>

Hi Mariam,

Thank you for reaching out to us. Give me a call when you get a minute and I can discuss prices with you. My number is [253-642-7041](tel:253-642-7041).

Thanks,

Jeff

[Quoted text hidden]

--

Jeff Dupont | Operations Manager

Sound Painting Solutions, LLC

(253) 642-7041

Connect via [LinkedIn](#) or like us on [Facebook](#)soundpaintingsolutions.com

Mariam Hovhannisyan <mariamhovhan@gmail.com>

Tue, Nov 24, 2015 at 8:14 AM

pg. 182

Mariam Hovhannisyan

MARCH Thesis

11/24/2015 12:47 PM

To: Jeff Dupont <jeff@soundpaintingsolutions.com>

Jeff, here's some more information on each of the wall types as discussed via phone:

1) Metal stud wall with GWB (need \$/SF paint)

- This is an interior wall, non load-bearing
- There is a dropped acoustical ceiling (2x2 grid)
- The wall is 9-10ft tall
- The paint will most likely be a satin or egg shell finish
- There will be paint on both sides of the wall

2) CLT Wall (Solid Wood wall)

- Also interior, non load-bearing partition
- There is no dropped ceiling, but assume a 9-10ft height of wall
- I would anticipate a stain and clear coat on the wood surface
- This paint would also be on either side of the wall
- This finish would also likely be used on glulam beams and columns in the space

For now, I am excluding trim & finishes and just looking for a SF of paint/finish on a flat surface.

Let me know if you have any other questions!

Mariam

[Quoted text hidden]

Jeff Dupont <jeff@soundpaintingsolutions.com>
To: Mariam Hovhannisyan <mariamhovhan@gmail.com>

Tue, Nov 24, 2015 at 12:00 PM

Hi Mariam,

1. Would be \$2.39 per square ft.
2. \$2.80 per square ft.

I hope this helps.

Good luck!

Best,

Jeff

[Quoted text hidden]

Mariam Hovhannisyan <mariamhovhan@gmail.com>
To: Jeff Dupont <jeff@soundpaintingsolutions.com>

Tue, Nov 24, 2015 at 12:47 PM

Thanks Jeff!

[Quoted text hidden]