

THE INTERSECTION OF ARTIFICIAL INTELLIGENCE AND HEALTHCARE

THE FUTURE OF PRIMARY CARE MEDICINE

Submitted by

Hussain Akram Altamimi

Department of Interdisciplinary Arts and Sciences

In partial fulfillment of the requirements

For the Degree of Master of Arts in Policy Studies

University of Washington

Bothell, Washington

Summer 2018

Master's Committee

Advisor: Keith Nitta

Co-Advisor: Bruce Kochis

Abstract

In just the past six years, advances in computer hardware, the development of new algorithms, and great collections of data have created an environment rich in the development of Artificial Intelligence. Meanwhile, every year millions of Americans young and old, rich and poor continue to seek medical care. This study conducts a qualitative analysis through interviews with primary care physicians and literature review of journal publications about medical professionals and their willingness, thoughts, and reservations about using Artificial Intelligence image recognition software in their medical practice. This paper draws two conclusions one, that doctors are open to using Artificial Intelligence in supportive capacities helping them in diagnosing patients; and doctors do not believe Artificial Intelligence programs should serve patients alone. Two, This paper recommends that the U.S. Senate Amend Senate Bill 2217 “The Future of AI,” Act to include an exploratory subcommittee that will continue and expand the research conducted in this study and recommend policies that promote the adoption of Artificial Intelligence in the medical field.

“The machines have finally come for the white collared, the college graduates, the decision makers, and it’s about time.”

— Garry Kasparov, *Deep Thinking: Where Machine Intelligence Ends and Human Creativity Begins*

Problem Statement

Every year approximately 12 million patients in the United States suffer from some kind of misdiagnosis.¹ As a result it is estimated between 44,000 and 98,000 Americans experience a resulting early death.² Diagnostic errors are prevalent across all areas of medicine, ranging from breast cancer wherein one study found 25% of cases were misdiagnosed or misclassified,³ to heart disease which was misdiagnosed 28% of the time.⁴ Aside from the loss of life, pain and suffering, the economic effect of these misdiagnosis is estimated to cost the U.S. an estimated \$750Billion per year.⁵

These statistics are not a commentary on the quality of America’s doctors, after all to become a licensed medical practitioner in the U.S. students must undertake a four-year undergraduate degree followed by four years of medical school and then up to seven years of medical residency.⁶ On the contrary, the juxtaposition of the rate of misdiagnosis and the level of education for doctors underlines the difficulty and complexity medical professionals face in trying to accurately diagnose patients. This problem is exacerbated by the fact doctors are overworked. A 2013 study published in the *Journal of the American Medical Association*

¹ Ball, J., Balogh, E., & Miller, B. T. (2015). *Improving diagnosis in health care*. Washington, DC: The National Academies Press.

² McDonald CJ, Weiner M, Hui SL. Deaths Due to Medical Errors Are Exaggerated in Institute of Medicine Report. *JAMA*. 2000;284(1):93–95. doi:10.1001/jama.284.1.93

³ Elmore, J., Longton, G., Carney, P., Geller, B., Onega, T., Tosteson, A., . . . Weaver, D. (2015). Diagnostic Concordance Among Pathologists Interpreting Breast Biopsy Specimens. *JAMA*, 313(11), 1122-1132.

⁴ Thedoctors.com (Tech.). (2016, January 11). Retrieved July 24, 2018, from The Doctors Company website: https://www.thedoctors.com/siteassets/pdfs/risk-management/closed-claims-studies/10579_ccs-internalmed_nomarks_fr.pdf

⁵ “Pinnacle Care. (2016). *The human cost and financial impact of misdiagnosis*. Washington D.C.”

⁶ Grady, Denise. “The Drawn-Out Medical Degree.” *The New York Times*, *The New York Times*, 1 Aug. 2014, www.nytimes.com/2014/08/03/education/edlife/the-drawn-out-medical-degree.html.

Internal Medicine, found that 40% of doctors surveyed responded that at least monthly their patient workload exceeded safe limits leading to misdiagnosis.⁷ However, in the same way the tractor reduced the farmer's workload and improved technology could pick plants more efficiently, additional automation and computer support could stand to do the same for the medical field.

In 1956 famed computer scientist John McCarthy coined the term “Artificial Intelligence.” Since, the concept of robots rivaling the intelligence of humans has captivated pop culture with blockbuster hits, *The Terminator* and *iRobot* tell the stories of super intelligent robots interacting with human society.^{8,9} However, this paper will focus on a much more modern and real-world view towards Artificial Intelligence. Artificial Intelligence, often abbreviated as A.I. has two subsets, Artificial General Intelligence, which is showcased on big movie screens and Narrow Artificial Intelligence, which despite commonly referred to as Artificial Intelligence, differs in that Narrow A.I. is optimized to accomplish only very specific tasks incredibly well. For the purposes of this study I will focus on Narrow A.I. and refer to it colloquially as Artificial Intelligence as we will not be discuss Artificial General Intelligence.

This paper will assess the future of Artificial Intelligence in the healthcare industry through interviews with physicians and cross referencing first hand findings with academically published interviews to identify policy openings to better promote Artificial Intelligence in healthcare.

⁷ Michtalik HJ, Yeh H, Pronovost PJ, Brotman DJ. Impact of Attending Physician Workload on Patient Care: A Survey of Hospitalists. *JAMA Intern Med.* 2013;173(5):376–377. doi:10.1001/jamainternmed.2013.1864

⁸ *The Terminator*. (n.d.). In IMDB. Retrieved from <https://www.imdb.com/title/tt0088247/>

⁹ *iRobot*. (n.d.). In IMDB. Retrieved from <https://www.imdb.com/title/tt0343818/>

Literature Review

The United States healthcare industry comprises the largest segments of the U.S. economy, totaling \$3.3 trillion, around 7.9% of GDP in 2016.¹⁰ These statistics are reflected by sheer traffic, as nearly 9 in 10 Americans report to have contacted a healthcare professional within the past year,¹¹ most of whom with their primary care physician. In 2016, primary care visitations outnumbered hospital visitations by a nearly 10 to 1 margin at 990.8 million visits compared to 125.7 million.^{12,13} This statistic reflects the role the primary care physician plays, operating as the central contact point in the medical field, the physicians is the first line of defense towards illnesses and diagnosis. The physicians work to diagnose, treat, track, and coordinate care with their patients, a role that keeps on asking more and more of its principle actors.

“A hundred years ago medical treatments were basic, cheap and not terribly effective; often run by religious charities, hospitals were places people mostly went to die.”¹⁴ Until recently, healthcare has existed more as a concept than a practice.¹⁵ Diagnosis relied more on guess and superstition rather than evidence and science; and procedures asked doctors to act

¹⁰ CMS. (2017). National Health Expenditures 2016 Highlights (United States, Centers for Medicare and Medicaid Services, U.S. Health and Human Services). Baltimore, MD: United States Federal Government.

¹¹ Centers for Disease Control and Prevention. (2016). Summary Health Statistics: National Health Interview Survey. Retrieved from https://ftp.cdc.gov/pub/Health_Statistics/NCHS/NHIS/SHS/2016_SHS_Table_A-18.pdf

¹² Centers for Disease Control and Prevention. (2011). National Hospital Ambulatory Medical Care Survey: Emergency Department Summary Tables. Retrieved from https://www.cdc.gov/nchs/data/ahcd/nhamcs_emergency/2011_ed_web_tables.pdf

¹³ Centers for Disease Control and Prevention. (2015). National Ambulatory Medical Care Survey: State and National Summary Tables. Retrieved from https://www.cdc.gov/nchs/data/ahcd/namcs_summary/2015_namcs_web_tables.pdf

¹⁴ Rosenthal, E. (2017). The Age of Insurance. In *An American sickness: How Healthcare Became Big Business and How You Can Take it Back* (pp. 11-12). New York, NY: Penguin Press.

¹⁵ Rosenthal, E. (2017). The Age of Insurance. In *An American sickness: How Healthcare Became Big Business and How You Can Take it Back* (pp. 13-21). New York, NY: Penguin Press.

more like butchers than medical professionals.¹⁶ Time was both enemy and friend, either the sick would naturally improve, or, they would deteriorate until they died. In modern times however, medicine has seen a radical transformation unlike few fields. Whereas, farming despite technological advancements, such as GPS guided tractors, has remained more or less the same; as farmers still plant their seeds, water their crops, and harvest them when ripe. The medical field has adopted an entirely new approach reliant on new methods, sciences, and technology. This dramatic shift has shown itself as life expectancy has grown more than 50% from the early 1900's to the year 2000.¹⁷ The economic return from increases in life expectancy has been staggering, with a report published by University of Chicago economists Kevin Murphy and Robert Topo estimating that between 1970-1990 life expectancy increases return roughly \$57 trillion or about \$2.8 trillion per year.¹⁸

Medical advances responsible for increases in life expectancy have come to fruition only recently in human history. In 1846, when, Dr. William T.G. Morton successfully accomplished the first surgical procedure with the use of anesthesia, tempering the worst aspect of surgery, pain.¹⁹ In 1928, Professor of Bacteriology Alexander Fleming discovered the world's first antibiotic, penicillin, creating the industry of antibiotics.²⁰ And in 1952, punch cards were used by medical professionals to record and compare data between different hematological diseases, followed by an upgrade to a computer in 1961--this was the beginning of the digital age of

¹⁶ Kelly, R.E. "SURGERY 100 YEARS AGO." *The Lancet* 229, no. 5936 (1937): 1361-363.

¹⁷ Riley, J. (2001). *Rising life expectancy: A global history*. Cambridge; New York: Cambridge University Press.

¹⁸ National Research Council (US) and Institute of Medicine (US) Board on Science, Technology, and Economic Policy; Aspden P, editor. *Medical Innovation in the Changing Healthcare Marketplace: Conference Summary*. Washington (DC): National Academies Press (US); 2002. 3, The Costs and Benefits of Medical Innovation. Available from: <https://www.ncbi.nlm.nih.gov/books/NBK220598/>

¹⁹ Robinson, D. H., & Toledo, A. H. (2012). Historical Development of Modern Anesthesia. *Journal of Investigative Surgery*, 25(3), 141-149. doi:10.3109/08941939.2012.690328

²⁰ Fielding, & Tyrer. (1980). HISTORY OF PENICILLIN. *The Lancet*, 315(8158), 43-44.

medicine.²¹ Now, individuals can go online through their health insurance provider and attend a 30 minute doctor's appointment without ever leaving their home. These technological advancements have created an entirely new industry valued at \$143 billion dollars in 2016.²² These technologies have given medical professionals the tools to increase the quality of life for millions of people, the service of which is reflected in societal attitudes where a 2016 a Pew research poll showed that 84% of Americans had a positive impression of medical professionals,²³ a level of trust and support only rivaled by the military. However, the support and trust put in doctors is not the same in Artificial Intelligence with a Pew research poll finding that 72% of American expressed some level of concern about Artificial Intelligence doing human jobs and only 33% expressing any level of enthusiasm.²⁴ This paper intends to explore this concept further by asking professionals and service providers about their views on artificial intelligence. But before we can do that, we must understand how Artificial Intelligence works and what we are looking at.

To sufficiently understand the state, challenges, and future of Artificial Intelligence, it is important to understand the hardware that Artificial Intelligence algorithms are run on. The hardware used in all computers remains more or less the same and is fundamentally comprised of similarly simple designs summarized in six components.

²¹ Lipkin, M. (1984). Historical Background on the Origin of Computer Medicine. Proceedings of the Annual Symposium on Computer Application in Medical Care, 987-990.

²² Medpac. (2017). June 2017 Report to the Congress: Medicare and the Health Care Delivery System (pp. 207-242) (United States, Congress, Medicare Payment Advisory Commission (U.S.)). Washington, DC: Medicare Payment Advisory Commission.

²³ Kennedy, B. (2016, October 18). Most Americans trust the military and scientists to act in the public's interest. Retrieved July 13, 2018, from <http://www.pewresearch.org/fact-tank/2016/10/18/most-americans-trust-the-military-and-scientists-to-act-in-the-publics-interest/>

²⁴ Smith, A., & Anderson, M. (2017, October 04). 2. Americans' attitudes toward a future in which robots and computers can do many human jobs. Retrieved July 28, 2018, from <http://www.pewinternet.org/2017/10/04/americans-attitudes-toward-a-future-in-which-robots-and-computers-can-do-many-human-jobs/>

The simplest component is the power supply, charged with providing and regulating the needed electricity to the components that comprise any computer the power supply accomplishes one of the simplest yet most vital task. Conversely, the most complex component is the Central Processing Unit (CPU). Most akin to the human brain, the CPU takes in information (fetch), translates the information (decode), takes an action (execute), and notifies the rest of the system of its action (store).²⁵ The CPU is essentially the “boss,” of all computer hardware, serving to direct and coordinate all functions within the system, the CPU just like the brain, delegates responsibilities, sets objectives, and most fundamentally turns inputs into outputs. The CPU has to both access and store information somehow, and this is where computers take advantage of two different kinds of memory; volatile memory, meaning requiring power and non-volatile memory, meaning not requiring power. The tradeoff allows volatile memory to be significantly faster than its counterparts, however at lower capacities, higher costs, and the cost of only being able to maintain information only as long as power is provided to the machine.

Dynamic Random-Access Memory (DRAM) most commonly referred to as RAM is volatile memory placed near the CPU on the motherboard and is used as a medium between information fetched from permanent data storage to the CPU. The component in which data is stored permanently is called the storage drive stored in either a mechanical and magnetic “Hard Drive,” or a silicon “Solid State Drive.” Permanent storage’s main drawback is its incredibly slow nature

²⁵ Stallings, W. (2016). Computer organization and architecture: Designing for performance (Tenth ed.). Boston: Pearson-Prentice Hall.

and high latencies,²⁶ however, due to its nonvolatile nature, it allows data to be stored permanently.²⁷

Finally, the Graphics Processing Unit (GPU) is an ancillary component that provides high levels of specialized computational power. The GPU works in tandem with the CPU and is optimized to solve programs that require large computational solutions that stand to benefit from parallelization. This because, CPUs specialize in sequential computations, your computer does not know what the next letter you're going to type into your keyboard is, however because it can react quickly, the CPU is assigned this task. Whereas CPUs are good in sequential computations, GPU's specialize in parallelized computations. Meaning they can solve many computations at one time but are slow solving sequential problems. An analogy for to draw on the CPU vs GPU comparison is a Ferrari vs Semi-Truck, if you need to deliver one package across town very quickly, then you are best off using your Ferrari, however if you need to deliver many packages, instead of taking multiple trips in your Ferrari, using a Semi-Truck and taking one trip would be the faster option. An additional, but important factor is GPUs are limited to just addition, essentially, they can only solve $y = mx + b$, however in computer science, this question can be written in many ways, allowing for great flexibility. Historically this is why GPUs have been tasked to draw visuals onto displays, render movies, and games. But now because of their flexibility, wide spread availability, and powerful computational performance GPUs are

²⁶ Bright, P. (2017, April 24). Intel Optane Memory: How to make revolutionary technology totally boring. Retrieved July 06, 2018, from <https://arstechnica.com/gadgets/2017/04/intel-optane-memory-how-to-make-revolutionary-technology-totally-boring/>

²⁷ Sun, C., Okamoto, S., Hachiya, S., Yamada, T., & Takeuchi, K. (2016). Design guidelines of storage class memory/flash hybrid solid-state drive considering system architecture, algorithm and workload characteristic. *Consumer Electronics, IEEE Transactions on*, 62(3), 267-274.

becoming one of the bedrocks of modern Narrow Artificial Intelligence development.²⁸ The final component comprising these computers is the one responsible for connecting them, the motherboard, which uses a hardware and software interface called Peripheral Component Interconnect Express often abbreviated as PCIe.²⁹ This acts as the technology worlds highway system and the relationship between these parts is demonstrated in this illustration below.

Not absolutely sure we need the above basics about computers. Something quicker and to the point would be better.

²⁸ Artificial Intelligence; Liqid and Inspur Systems Showcase Next-Generation Composable NVIDIA GPU Accelerated Platform for Artificial Intelligence. (2017, December 18). *Journal of Robotics & Machine Learning*, p. 56.

²⁹ Micro Semi. (n.d.). Peripheral Component Interconnect (PCI) Express PCIe Technology. Retrieved July 01, 2018, from <https://www.microsemi.com/company/technology/pci-express-pcie-technology>

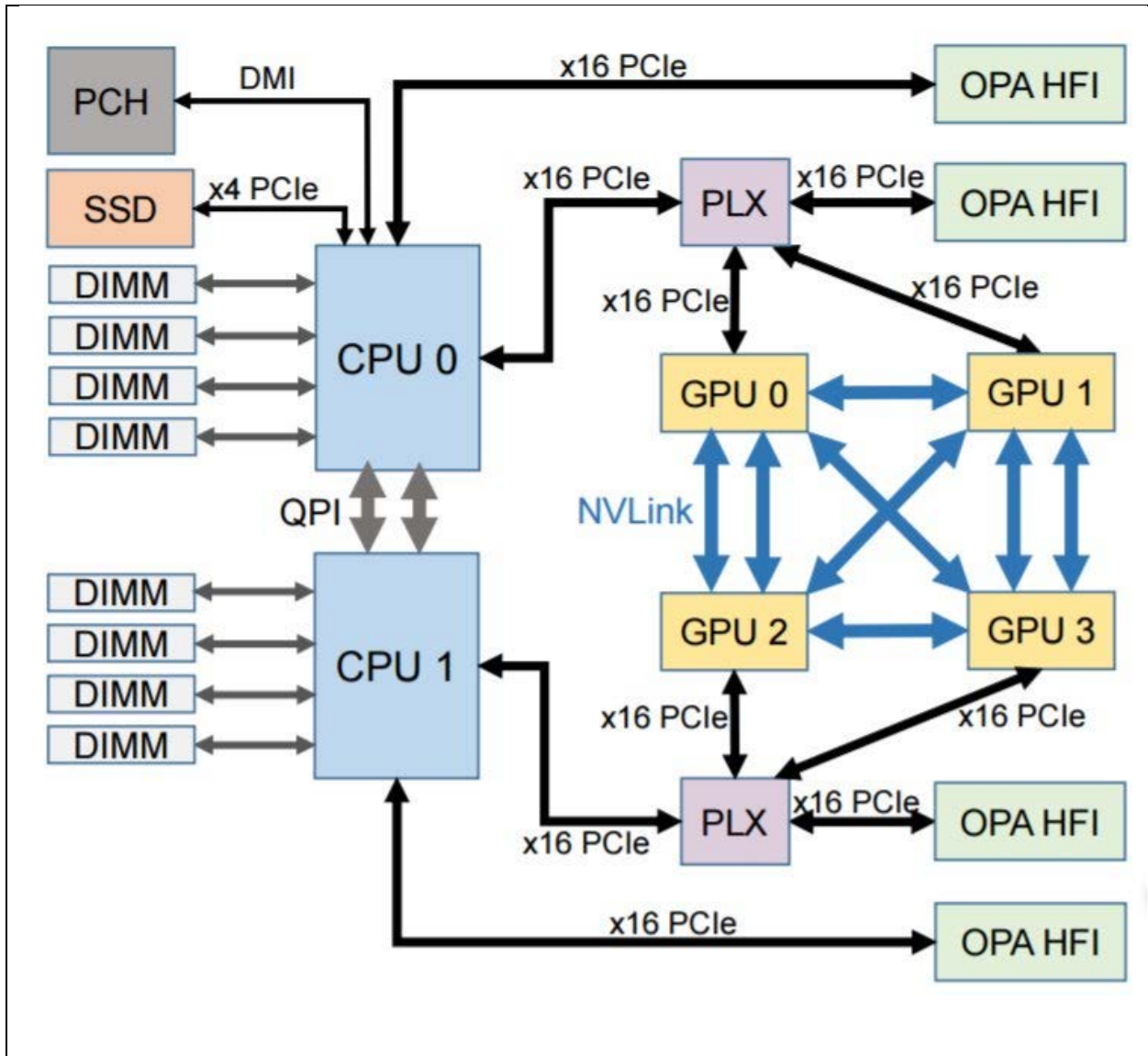

The above components have existed for decades and are still working in conjunction to form the computers powering our modern Artificial Intelligence renaissance.³⁰ So then, why have we only recently begun seeing the development of true narrow Artificial Intelligence? Well, according to computer scientist and author Jerry Kaplan, the answer is simple. Computers are more than a million times more powerful today than they were in the 1960's.³¹ To provide context, compare the speed of a snail to that of the International Space Station, which circles the earth every 90 minutes; the difference in speed is only a factor of 500,000.³² The main driver of the tremendous increases in computational power has been the result of relentless transistor node shrinkages going from microns in size to nanometers. Intel Co-founder Gordon Moore observed the trend of transistors shrinking in 1975 and determined the number of transistors in a given area would double every 18 months. The observation, coined Moore's law,³³ explains how Intel went from packing 2,300 transistors in their first CPU, the "Intel 4004,"³⁴ to packing 100 million transistors into a single square millimeter of silicon in 2018.³⁵ This exponential growth is expected end soon and instead researchers are switching to specialized computer hardware called ASIC or Application Specific Integrated Circuits.³⁶ These are processors with very limited functions, oftentimes created to solve a specific problem using a narrow set of operations. They

³⁰ Eshelman, E. (2017, January 26). NVLink vs PCI-E with NVIDIA Tesla P100 GPUs on OpenPOWER. Retrieved July 25, 2018, from <https://www.microway.com/hpc-tech-tips/comparing-nvlink-vs-pci-e-nvidia-tesla-p100-gpus-openpower-servers/>

³¹ Kaplan, J. (2015). Teaching Computers to Fish. In *Humans Need Not Apply: A Guide to Wealth and Work in the Age of Artificial Intelligence* (pp. 27-29). New Haven, Conn: Yale U.P.

³² Kaplan, J. (2015). Teaching Computers to Fish. In *Humans Need Not Apply: A Guide to Wealth and Work in the Age of Artificial Intelligence* (pp. 30-31). New Haven, Conn: Yale U.P.

³³ Thackray, A., Brock, David, & Jones, Rachel. (2015). *Moore's law: The life of Gordon Moore, Silicon Valley's quiet revolutionary*. New York: Basic Books, a member of the Perseus Books Group.

³⁴ Intel. (n.d.). The Story of the Intel® 4004. Retrieved from <https://www.intel.com/content/www/us/en/history/museum-story-of-intel-4004.html>

³⁵ Courtland, R. (2017, March 30). Intel Now Packs 100 Million Transistors in Each Square Millimeter. Retrieved from <https://spectrum.ieee.org/nanoclast/semiconductors/processors/intel-now-packs-100-million-transistors-in-each-square-millimeter>

³⁶ Cieszewski, Radosław. (2012). Accelerating artificial intelligence with reconfigurable computing. 8454. 84541L-1. 10.1117/12.2000098.

do one thing and one thing very well; ASIC processors exchange general usability for increased performance solving specific tasks. An example of this is Google's TPU or Tensor Processing Unit, which calculates the formula $y = mx + b$, using a matrix, allowing for a huge increase in parallel computational performance, enabling Google to compute Narrow Artificial Intelligence tasks very quickly.³⁷ The combination of transistor shrinkages along with new hardware architectures like NVidia's new V100 graphics chips has allowed one their processors to generate 74 gigaflops of performance per watt and 100 Teraflops per card consuming only 350 watts,³⁸ in comparison, the most powerful super computer in 2004, the IBM Blue Gene/L, was comprised of 64 cabinets, containing 65,536 nodes, which held 131,072 CPUs and consumed 1280 kilowatts of energy all for over 70 teraflops of performance.

Yet, despite the exponential increases in computational power the logistical, space, and cost restrictions form an economic and usually physical barrier for individual practices and hospitals looking to incorporate Narrow Artificial Intelligence into their practice. As a result companies have taken to using cloud computing to run the computations on their software, the benefit of this allows clients to circumvent creating local mainframes and utilizing servers offered by service providers.³⁹ This provides the additional benefit of updating the data of one server hosting multiple clients instead of each client mainframe having to undergo an update, which is exceedingly beneficial considering the amount of data needed for Machine Learning.

³⁷ Sato, K. Patterson, D. (2017, May 12). An in-depth look at Google's first Tensor Processing Unit (TPU) | Google Cloud Big Data and Machine Learning Blog | Google Cloud. Retrieved July 10, 2018, from <https://cloud.google.com/blog/big-data/2017/05/an-in-depth-look-at-googles-first-tensor-processing-unit-tpu>

³⁸ http://icl.cs.utk.edu/projectsfiles/magma/pubs/74-gtc18_iterreftc_poster.pdf

³⁹ Lee, R., & Ishii, Naohiro. (2009). Software engineering, artificial intelligence, networking and parallel/distributed computing (Studies in computational intelligence, v. 209). Berlin: Springer.

As computers have grown exponentially in power, people all over the world have been, without much thought, naturally, and simultaneously crowdsourcing and storing petabytes of data onto the World Wide Web. This explosion of information combined with its centralization into a publicly open and electronically accessible domain has created a treasure trove of data accessible to millions of people and perhaps more importantly, computers. The enormous amount of accessible data has allowed researchers to develop new statistical algorithms based on the subject area of machine learning. The concept of Machine learning, often abbreviated as ML, is defined by its earliest pioneer Arthur Samuel in 1959 as “[A] Field of study that gives computers the ability to learn without being explicitly programmed.”⁴⁰ The terms “learn,” and “explicit,” are the most fundamental differentiation between normal computer function and Artificial Intelligence. They are the ingredients needed to overcome the hump that relegates computers to the realm of mindlessness.

Machine learning relies on running a specialized set of proven statistical algorithms with parameters around a specific goal in mind. This is the limitation placed on modern programmers and why we are stuck in the classification of Narrow A.I. There are two main classes of machine learning algorithms, supervised and unsupervised. Similar to how a teacher or parent may decide it best to leave a child to solve problems on their own, for example what shape fits into what hole, a different circumstance may lead that teacher or parent to directly mentor the child, for example grammar; programmers draw on the same thought process. Programmers, data scientists, and or mathematicians need to decide which method of teaching they may want to deploy to their algorithm. Supervised learning involves creating a set of labeled training data for

⁴⁰ Wiederhold, Gio, McCarthy, John, & Feigenbaum, Ed. (1990). Arthur Samuel: Pioneer in machine learning. (obituary). *Communications of the ACM*, 33(11), 137.

the algorithm to draw reference from. In essence the programmer provides a legend for the algorithm to reference and based on that legend the algorithm builds a library based on the legend and the adjacent data set.

Author Jason Bell Provides the below example of supervised learning using twitter.⁴¹

	Really loving the new St Vincent album!
	#fashion I'm selling my Louboutins! Who's interested? #louboutins
	I've got my Hadoop cluster working on a load of data. #data
	“In order for your supervised learning classifier to know the outcome result of each tweet, you have to manually enter the answers; for clarity, I’ve added the resulting output object at the start of each line.”
music	Really loving the new St Vincent album!
clothing	#fashion I'm selling my Louboutins! Who's interested?
	#louboutins

⁴¹ Bell, J. (2015). What is Machine Learning. In Machine Learning: Hands-On for Developers and Technical Professionals (p. 3). Indianapolis, IN: John Wiley & Sons.

```
bigdata      I've got my Hadoop cluster working on a load of data.
#data
```

In this instance of supervised learning the programmer would gather tweets about three different subjects: music, clothing, and data. Then the programmer would label each tweet, which in this example is three; however, of course, actually it would be much more. By doing this, the programmer has given the algorithm a reference sheet to use as a training set when analyzing future data.

The other type of machine learning is unsupervised learning, this is where you give the computer a large amount of data and allow it to find patterns on its own. In this instance, you have not determined the outcome before giving the data to the computer, whereas in supervised learning, you are expecting all tweets about the St Vincent album to be labeled music, neither you or the computer have any such expectations for unsupervised learning. Unsupervised learning relies on a data strategy called “clustering.” There are two types of clustering, hierarchical clustering, which arranges a set of objects into a hierarchy, for example home prices, and nonhierarchical clustering, which partitions data into “clusters,” which can be viewed as categories, such as object by color or age.⁴² An example of unsupervised learning is running national car accident data; an unsupervised algorithm could end up clustering car accidents by state, time of day, time of year, color of car, and much more all without being given any specific instruction to do so. To run these algorithms, an immense amount of data needs to be run and

⁴² Kulkarni, P. (2012). Introduction to Reinforcement and Systemic Machine Learning. In Reinforcement and Systemic Machine Learning for Decision Making (IEEE Press series on systems science and engineering, pp. 3-4). Hoboken, NJ: John Wiley & Sons.

needs to be run repeatedly. Datasets used for machine learning usually run through statistical algorithms called Deep Neural Networks, that are loosely based on the human brain and like we discussed above, cluster and classify data. These networks need to consume terabytes if not petabytes of data in order to become accurate,⁴³ and require massive computational power to run the intense statistical algorithms across the large datasets. The computational power is expressed as Floating-Point Operations Per Second or FLOPS, which are defined as “the addition or multiplication of single (32 bit) or double (64 bit) numbers...”⁴⁴

The concept of modeling software and hardware after the human brain is not a new one, in fact the concept has been around since before the inception of the first computers.⁴⁵ Yet, only within the past decade Narrow Artificial Intelligence has begun to see significant development.⁴⁶ This is where everything we have discussed before comes together. Artificial Intelligence requires extremely large datasets to sift through, data sets that have only been made possible by the advent of the internet. Running advanced statistical algorithm’s and sifting through all of that data takes an immense amount of computational power, something made possible by the exponential growth in computer performance and development of specialized hardware. The marrying of these two, big data, and powerful hardware, has created the platform for a new market of medical devices called intelligent medical devices.

The Medical Application and Policies

⁴³ Bell, J. (2015). What is Machine Learning. In *Machine Learning: Hands-On for Developers and Technical Professionals* (p. 223-224). Indianapolis, IN: John Wiley & Sons.

⁴⁴ Parker, M. (2014, October 20). Understanding Peak Floating-Point Performance Calculations. Retrieved July 07, 2018, from https://www.eetimes.com/author.asp?section_id=36&doc_id=1324326

⁴⁵ Paluszek, M., & Thomas, Stephanie. (2017). *MATLAB machine learning*. New York, NY?]: Apress.

⁴⁶ Takahashi, D. (2018, May 14). Nvidia's Jensen Huang on the White House's AI initiative. Retrieved July 07, 2018, from <https://venturebeat.com/2018/05/13/nvidias-jensen-huang-on-the-white-houses-ai-initiative/>

This leads us to the companies currently taking advantage and advancing the new platform of intelligent medical devices. Viz A.I., Rad logics, and Arterys are all technology companies that have created image recognition algorithms to aid in the diagnosis in MRI's, CAT Scans, and X-Rays. All companies have had A.I. related products approved by the FDA within the past seven years, the

The Food and Drug Administration's (FDA) Center for Devices and Radiological Health (CDRH) is the division within the FDA that is responsible for regulating and approving Computed Tomography medical devices sold or transferred within the United States.⁴⁷ The first step of the process is Establishment Registration," wherein the petitioning company registers their corporation with the FDA registering their intentions as a medical device company.⁴⁸ The next step is registering their devices using the following guidelines listed by the FDA:

- manufacturers,
- contract manufacturers that commercially distribute the device,
- contract sterilizers that commercially distribute the device,
- repackagers and relabelers,
- specification developers,
- reprocessors single-use devices,

⁴⁷ Center for Devices and Radiological Health. (n.d.). Overview of Device Regulation. Retrieved from <https://www.fda.gov/medicaldevices/deviceregulationandguidance/overview/default.htm>

⁴⁸ Code of Federal Regulations, Title 21, Part 807, Subpart B, § 807.2 - § 807.23

- remanufacturer
- manufacturers of accessories and components sold directly to the end user
- U.S. manufacturers of "export only" devices

Next, the petitioning corporation must file for a Premarket Notification 510(k),⁴⁹ wherein the medical device must be demonstrated to be “substantially equivalent to one legally in commercial distribution in the United States.”⁵⁰ Once given approval, the petitioning company may begin advertising its product on the open market, unless it is a class III medical device . The FDA regulates the premarket approval process using a Class I-III scale; and regulates the marketing of the device, registration and listing, and GMP’s.⁵¹ Class I medical devices as defined by the FDA are the lowest risk carrying devices, an example is a stethoscope, 47% of medical devices fall in this category and 95% are exempt from the regulatory process.⁵² Class II medical devices comprise 43% of medical devices and examples are wheelchairs and pregnancy kits.⁵³ Finally, Class III medical devices usually sustain or support life, like pacemakers. After classification depending on the category companies must receive additional premarket approval.⁵⁴

In 2011 Radlogics was the first company to be given 510(k) approval for an Artificial Intelligence program called the AlphaPoint Imaging Software. Radlogics and its software make for an accurate representative of the medical Artificial Intelligence industry, their programs uses

⁴⁹ Code of Federal Regulations, Title 21, Part 807, Subpart E, § 807.81- § 807.100

⁵⁰ Center for Devices and Radiological Health. (n.d.). Overview of Device Regulation. Retrieved from <https://www.fda.gov/medicaldevices/deviceregulationandguidance/overview/default.htm>

⁵¹ Center for Devices and Radiological Health. (n.d.). Overview of Class I/II Exceptions. Retrieved from <https://www.fda.gov/medicaldevices/deviceregulationandguidance/overview/classifyyourdevice/ucm051549.htm>

⁵² Center for Devices and Radiological Health. (n.d.). Learn if a Medical Device Has Been Cleared by FDA for Marketing. Retrieved from <https://www.fda.gov/MedicalDevices/ResourcesforYou/Consumers/ucm142523.html>

⁵³ Learn if a Medical Device Has Been Cleared by FDA for Marketing

⁵⁴ Code of Federal Regulations, Title 21, Part 814, § 814.1 - § 814.126

Machine Learning running on supercomputers in the cloud to scan MRI's, CT-Scans, X-Rays, and Ultrasound scans. Which is same computing and business model that FDA approved companies like Viz.ai and Arterys are undertaking. Traditionally, radiologists diagnose images themselves accessed through picture archiving and communication systems (PACS),⁵⁵ an onsite intra-net. Alphapoint utilizes the cloud, stripping medical records from the images sent to their servers, running their algorithm, then reapplying the medical records to diagnose patient images.⁵⁶

Below is an example of what the system shows the doctor.⁵⁷

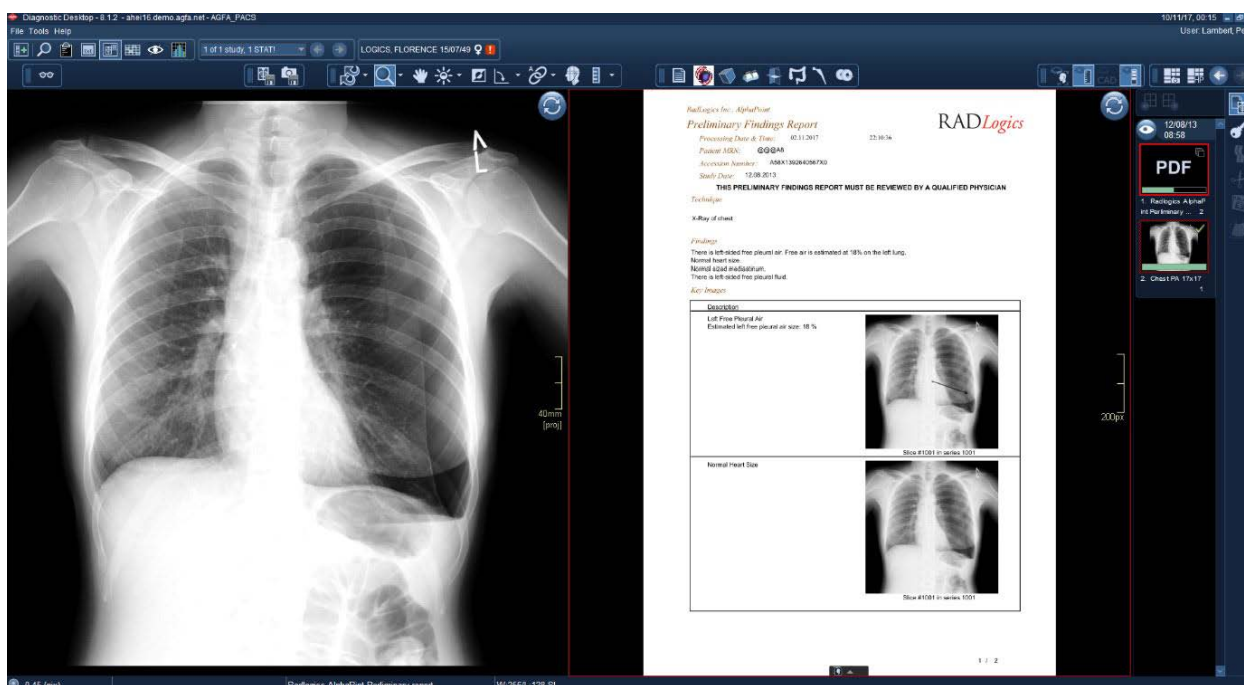

⁵⁵ Strickland, N. (2000). PACS (picture archiving and communication systems): filmless radiology. Archives of Disease in Childhood, 83(1), 82–86. <http://doi.org/10.1136/adc.83.1.82>

⁵⁶ Kaplan, D. A. (2017, April 21). How Radiologists are Using Machine Learning. Retrieved from <http://www.diagnosticimaging.com/pacs-and-informatics/how-radiologists-are-using-machine-learning>

⁵⁷ <http://radlogics.com/>

Radlogics markets its AlphaPoint system as a “virtual resident,” claiming the diagnostic features of this product would allow radiologists to shift their focus into other areas of diagnostic. The most difficult challenge facing both doctors and Artificial Intelligence in the field of Medical Imaging is summarized in a quote from a 2007 article in the *American Journal of Roentgenology* “The reason a radiologist is required to assume that the overwhelming number of ambiguous things are normal, in other words, is that the overwhelming number of ambiguous things really are normal.”⁵⁸ The article then makes the analogy to the TSA scanning luggage for bombs, of all the thousands of bags that travel through the X-Ray machines at airports, many have items like laptops, hairdryers, and other products that can make the impression of there being a bomb when in reality, the impression is only that, an impression.

However, this is where Machine Learning applied to Medical Imaging can show its strength, the Artificial Intelligence programs by using Machine Learning can run simulations of already diagnosed cases millions of times. IBM researchers estimate that 90% of stored medical data is in the form of medical imaging.⁵⁹ Providing the opportunity to use the advanced statistical algorithms outlined before running millions of simulations to differentiate between what is ambiguous and not ambiguous. In a journal publication it was found that researchers in Indiana University were able to increase patient outcomes by implementing Artificial Intelligence into their diagnostic stage increasing outcomes by 30% to 35%.⁶⁰ Hospitals recognize this as a 2017 survey by Healthcare IT News and HIMSS Analytics HIT Market Indicator showed 35% of

⁵⁸ Berlin, L. (2007). Accuracy of Diagnostic Procedures: Has It Improved Over the Past Five Decades? *American Journal of Roentgenology*, 188(5), 1173-1178. doi:10.2214/ajr.06.1270

⁵⁹ Landi, H. (2016, December 1). IBM Unveils Watson-Powered Imaging Solutions at RSNA. Retrieved August 08, 2018, from <https://www.healthcare-informatics.com/news-item/analytics/ibm-unveils-watson-powered-imaging-solutions-rsna>

⁶⁰ Conn, J. (2013). Computing better healthcare. Artificial intelligence seen as aiding decision support. *Modern Healthcare*, 43(7), 14.

healthcare organizations had plans to implement some level of Artificial Intelligence into their medical practices in the next two years and nearly half in five years.⁶¹ The survey also found that 40% believed there was the greatest potential for impact in clinical decision support and patient diagnosis, however, despite the positive upsides, one of the barriers to adoption identified was physician and administrative buy in.⁶² This paper identifies physician beliefs through interviews and cross study analysis to understand policy solutions to increase buy-in for Artificial Intelligence in medical care.

Existing Research:

In a published article in the *Journal of Healthcare Transformation* Dr. Antonia F. Chen, MD, MBA, moderated a discussion between Dr. Adam C. Zoga, MD, and Dr. Alexander R. Vaccaro, MD, PhD, MBA, about opportunities and challenges of Artificial Intelligence in Healthcare.⁶³ Both Dr. Zoga and Dr. Vaccaro stated they believed that workflows would change by moving repetitive tasks to Artificial Intelligence, referencing “pre-processing,” stating it is a “...binary step that decides if a finding is present/not present,”⁶⁴ this step is where physicians rule whether there is something abnormal or not, a task that is done first for every medical image. Both doctors also believed Artificial Intelligence costs could be offset by a decrease in misdiagnosis and, having automation would allow doctors and specialists to shift their energy and skills to other areas.⁶⁵ Although notwithstanding the more imperative decisions in the

⁶¹ Artificial Intelligence Use in Healthcare Growing Fast. (2017). *Journal of AHIMA*, 88(6), 76.

⁶² Sullivan, T. (2017, April 19). Half of hospitals to adopt artificial intelligence within 5 years. Retrieved August 08, 2018, from <https://www.healthcareitnews.com/news/half-hospitals-adopt-artificial-intelligence-within-5-years>

⁶³ Chen, A., Zoga, A., & Vaccaro, A. (2017). Point/Counterpoint: Artificial Intelligence in Healthcare. *Healthcare Transformation*, 2(2), 84-92.

⁶⁴ Chen, A., Zoga, A., & Vaccaro, A. (2017). Point/Counterpoint: Artificial Intelligence in Healthcare. *Healthcare Transformation*, 2(2), 86.

⁶⁵ Chen, A., Zoga, A., & Vaccaro, A. (2017). Point/Counterpoint: Artificial Intelligence in Healthcare. *Healthcare Transformation*, 2(2), 89.

diagnosis line of a medical case. “In the field of medical oncology, you absolutely do not want to make a mistake in diagnosis, especially from imaging studies such as computed tomography (CT) scans...It would be beneficial to have systems in place where AI, through computer-aided detection, would detect a lesion and then is able to validate it before burdening a radiologist in order to minimize the occurrence of false-positive findings.”

A second published study was from the *Journal of Medical Imaging and Radiation Sciences* which interviewed 24 participants from the radiology field by dividing them into four focus groups discussed artificial intelligence. The focus groups concluded that there was not a threat to job loss in the radiology field and that Artificial Intelligence would provide opportunities to change workflows, redirect energy, and offload meticulous tasks to the algorithms. “Currently time-consuming repetitive tasks (contouring, treatment planning, and elements of quality assurance) were thought conducive to offloading to automation and machine learning.”⁶⁶ The focus groups also concluded that medical professionals should take an active role in assessing the potential impact of Artificial Intelligence and influencing the implementation.

Existing Regulations:

Surprisingly, research into existing legislation, resolutions, or policy by the federal government into Artificial Intelligence in healthcare returns zero results. Instead, the focus has only just shifted to the general field of Artificial Intelligence. On 12-12-2017 Senator Maria Cantwell

⁶⁶ Gillan, C., Harnett, N., Milne, E., Purdie, T., Wiljer, D., Jaffray, D., & Hodges, B. (2018). Professional Implications of Introducing Artificial Intelligence in Healthcare: An Evaluation using Radiation Medicine as a Testing Ground. *Journal of Medical Imaging and Radiation Sciences*, 49(1), 1-18. doi:10.1016/j.jmir.2018.02.006

announced legislation along with Senators Todd Young and Ed Markey to create a federal advisory committee on Artificial Intelligence.⁶⁷ The working committee is expected to bring stakeholders together to discuss the economic costs of automation and will be comprised of a mixture of public and private citizens focusing on four key areas.

- Potential growth, restructuring, and other changes for the U.S. workforce that result from adoption of AI, including potential actions to train and skill workers for an AI workplace
- Protecting the privacy rights of individuals as AI continues to grow
- Promoting a climate of innovation to ensure global competitiveness for American companies developing AI technologies
- Supporting the development and application of unbiased AI

The advisory committees' tasks are broad and ambitious, the legislation has not been passed yet,⁶⁸ so we have yet to see the results stemming from the committee, however it is worth keeping an eye on in the future as its work could be very relevant. ***Methodology and data:***

This paper conducted qualitative research with a sample population (n-1) of practicing physicians around the Seattle area ending with an interview with a presently practicing physician operating a practice in Everett, Washington approximately 14 miles from Seattle.

Application:

This process required an approval from the Internal Review Board of the University of Washington, the application was submitted on 07-17-2018 at 12:54 PM and received approval on 7/24/2018 at 4:56 PM. The application consisted of the zipline application provided by the

⁶⁷ Congress, Senate. (2017, December 12). Cantwell, Bipartisan Colleagues Introduce Bill to Further Understand and Promote Development of Artificial Intelligence, Drive Economic Opportunity [Press release]. Retrieved August 16, 2018, from <https://www.cantwell.senate.gov/news/press-releases/cantwell-bipartisan-colleagues-introduce-bill-to-further-understand-and-promote-development-of-artificial-intelligence-drive-economic-opportunity>

⁶⁸ FUTURE of Artificial Intelligence Act of 2017, S. 2217, 115th Cong. (2017).

University outlining the type of study, methodology and study material. I wrote a script for reaching out to physicians and technology companies over email and in person/phone contact and documented the results.

Data Collection:

On 07/30/2018 I contacted 3 physicians over the phone and 2 physicians over both phone and email and received either indeterminate, responses, or denials. I also contacted three technology companies through email, I received no response from two and one confirmation for an interview from one the next day. I sent a follow up email to both non-respondent companies on 08-06-2018 and still did not receive any response. Additionally, the technology company that originally accepted the interview delayed the interview twice, delaying it until it was no longer possible to interview them in time for this study. I reached out to eight more physicians on 08-06-2018 between 8:00 AM and 12:30 PM, this time in person, I was forwarded to the administrators and was either given a card with contact information or was denied in person. All physicians contacted were based out of Seattle, Lynnwood, Mill Creek, or Everett. One physician from Everett, Washington agreed for an interview. All data was saved in a contact sheet with the name of the practice, address, contact information, name of doctor, status of interview and date contacted. In total I contacted 13 offices with 15 physicians and three technology companies.

Interview:

The interview took place on 08-08-2018 at 11:28 and lasted 28 minutes and 55 seconds and was had over the phone. The interview was recorded then later transcribed, the doctor was

emailed a waiver providing consent to be recorded and for the interview to be used in research, the questions asked were as listed below.

Interview Questions

- Are you open to using an A.I. program to help you diagnose patients?
- Would you be willing to pay to use an Artificial Intelligence program in your practice?
- Would you be open to having your patients screened by an Artificial Intelligence Algorithm before meeting them?
- Would you be willing to use an Artificial Intelligence program if it meant not having to refer a patient to a specialist?
- What tasks or type of tasks could you see yourself shifting to an Artificial Intelligence program.
- What technological changes have you seen take place since you began practicing medicine and how have they changed your practice?
- What changes would you expect to see in your practice if you were to include the use of an Artificial Intelligence program? For example, would you take on more patients, change your time and effort, work less, etc.
- Do you believe there is a possibility doctors may one day be replaced by Artificial Intelligence programs?
- What advantages do you believe a human doctor has in diagnosis over an Artificial Intelligence program?
- How would a diagnosis differing from yours by an Artificial Intelligence program affect your decision on a patient?
- What is the mental process that you go about when evaluating patients?
- Do you believe an Artificial Intelligence Algorithm can operate independently, without the participation of a doctor?

References:

The technology referenced in interviews for this study is Artificial Intelligence Image Recognition algorithms. This technology was chosen because it is the field that Artificial Intelligence is sufficiently advanced in, having received multiple FDA 510(k) approvals. we interviewed a member from a company with FDA approval to run image recognition Artificial Intelligence algorithms in the medical field. The image recognition algorithm's read CT-Scans, MRI's and X-Rays. To provide background, I drew from more than 50 sources for the literature

review; and I referenced the published studies of doctor interviews on Artificial Intelligence I cross-referenced were from the *Journal of Medical Imaging and Radiation Sciences* 49 S1-S18 and *Healthcare Transformation Magazine* 2(2), 84-92.

The major limiting factors of this study were population, geography, time to contact subjects, finding agreeable subjects to interview and scheduling.

Results and Analysis

Overview

The themes of the interview addressed perceptions of the potential impact on workflow, quality of care, apprehension, and potential of Artificial Intelligence in healthcare. The subject was asked questions about how they expected to change their practice, any apprehension about Artificial Intelligence diagnosis and advantages/disadvantages they could see arising from the technology. Overall, the respondent was positive towards Artificial Intelligence and saw a big potential payoff if the technology were to be implemented.

Results and Data

The doctor explained, “I could see [using] some data analysis, interpretation of certain tests that do not require nuance. For example, there is interpretation of an EKG sometimes the data is correct, sometimes it is wrong, that radiology interpretation, human interpretation is enough prone to error, I could actually see A.I. being a good tool.” When asked what his response would be to an Artificial Intelligence program finding a different diagnosis than his, our respondent stated, “It would make me review my decision, to check the degree of confidence that I have in that decision, in the decision or the diagnosis that I made...” This was the same response given to Dr. Chen by Dr. Vaccaro. The commonality between findings indicates the

strength of Artificial Intelligence will be in automation of tasks and integration into support roles.

My interview also corroborated previous studies findings that physicians showed a willingness to pay for an Artificial Intelligence program to utilize in their practice. Dr. Jalali also stated that he sees Artificial Intelligence like MRI technologies or other medical records and it was worth paying for. The simplest model was a subscription-based cloud service, which is already offered by companies like Viz A.I. and Radlogics. The simplification of this model allows for avoidance of onsite hardware installations and the overhead that comes along with IT. A concern in which 16.9% of surveyed hospitals expressed as being a barrier to adoption.⁶⁹

The primary advantage that humans have over Artificial Intelligence is the ability to “...to detect nuanced information that is not just a data point. Sometimes it is what an individual does not say in response to a question that sometimes gives you more information than what they do say.” This point corroborates the *Journal of Medical Imaging’s* focus groups findings referenced in the literature review. With Dr. Jalali stating it would provide an opportunity for “...increasing interprofessional communication over the course of a patient’s treatment.” The human advantage is further ingrained with physician training, “For example, having to get a patient to lose weight in a sensitive matter, they will response positively, how do you give information that they have cancer, how do you deal with parents in the case of childhood disease, that in our field is 50% of what we do,”

Policy recommendation

It is the recommendation that the United States federal government should amend S.2217 The FUTURE of AI Act and include an exploratory subcommittee to continue this research.

⁶⁹ Sullivan, T. (2017, April 19). Half of hospitals to adopt artificial intelligence within 5 years. Retrieved August 08, 2018, from <https://www.healthcareitnews.com/news/half-hospitals-adopt-artificial-intelligence-within-5-years>

The committee should include actively practicing physicians, technology experts, administrators, insurance providers including representatives from Medicare and Medicaid. In addition to committee members the committee should ask for both written and oral testimony on the impact of Artificial Intelligence on medical practice and should include a review of previous technologies and their effects on the medical industry. I recommend that the committee should look for negative externalities resulting from the implementation of AI into the medical practice. Understanding the immediate economic impact would create a foundation to continue further research. Amending S.2217 would be a simple change to the bill but could stand to have a massive impact on the future of healthcare in the United States. As it stands the committee runs the risk of remaining too broad in practice and focusing its limited resources and efforts too broadly.

It is imperative that the United States Federal Government be the leading actor in regulating Artificial Intelligence. The technology showcases potential to have great impact on the future of both American health and the economy. By being the first to the table and correctly assessing the future of AI in healthcare the federal government can either accelerate or guide the technologies implementation across the country removing inequities that can arise from different state policies or lack of policy.

References

- “Pinnacle Care. (2016). The human cost and financial impact of misdiagnosis. Washington D.C.”
- Artificial Intelligence Use in Healthcare Growing Fast. (2017). *Journal of AHIMA*, 88(6), 76.
- Artificial Intelligence; Liquid and Inspur Systems Showcase Next-Generation Composable NVIDIA GPU Accelerated Platform for Artificial Intelligence. (2017, December 18). *Journal of Robotics & Machine Learning*, p. 56.
- Ball, J., Balogh, E., & Miller, B. T. (2015). *Improving diagnosis in health care*. Washington, DC: The National Academies Press.
- Bell, J. (2015). What is Machine Learning. In *Machine Learning: Hands-On for Developers and Technical Professionals* (p. 3). Indianapolis, IN: John Wiley & Sons.
- Berlin, L. (2007). Accuracy of Diagnostic Procedures: Has It Improved Over the Past Five Decades? *American Journal of Roentgenology*, 188(5), 1173-1178. doi:10.2214/ajr.06.1270
- Bright, P. (2017, April 24). Intel Optane Memory: How to make revolutionary technology totally boring. Retrieved July 06, 2018, from <https://arstechnica.com/gadgets/2017/04/intel-optane-memory-how-to-make-revolutionary-technology-totally-boring/>
- Center for Devices and Radiological Health. (n.d.). Overview of Device Regulation. Retrieved from <https://www.fda.gov/medicaldevices/deviceregulationandguidance/overview/default.htm>
- Centers for Disease Control and Prevention. (2015). National Ambulatory Medical Care Survey: State and National Summary Tables. Retrieved from https://www.cdc.gov/nchs/data/ahcd/namcs_summary/2015_namcs_web_tables.pdf
- Chen, A., Zoga, A., & Vaccaro, A. (2017). Point/Counterpoint: Artificial Intelligence in Healthcare. *Healthcare Transformation*, 2(2), 84-92.
- Cieszewski, Radosław. (2012). Accelerating artificial intelligence with reconfigurable computing. 8454. 84541L-1. 10.1117/12.2000098.
- CMS. (2017). *National Health Expenditures 2016 Highlights* (United States, Centers for Medicare and Medicaid Services, U.S. Health and Human Services). Baltimore, MD: United States Federal Government.
- Code of Federal Regulations, Title 21, Part 807, Subpart B, § 807.2 - § 807.23
- Conn, J. (2013). Computing better healthcare. Artificial intelligence seen as aiding decision support. *Modern Healthcare*, 43(7), 14.
- Courtland, R. (2017, March 30). Intel Now Packs 100 Million Transistors in Each Square Millimeter. Retrieved from <https://spectrum.ieee.org/nanoclast/semiconductors/processors/intel-now-packs-100-million-transistors-in-each-square-millimeter>
- Elmore, J., Longton, G., Carney, P., Geller, B., Onega, T., Tosteson, A., . . . Weaver, D. (2015). Diagnostic Concordance Among Pathologists Interpreting Breast Biopsy Specimens. *JAMA*, 313(11), 1122-1132.
- Eshelman, E. (2017, January 26). NVLink vs PCI-E with NVIDIA Tesla P100 GPUs on OpenPOWER. Retrieved July 25, 2018, from <https://www.microway.com/hpc-tech-tips/comparing-nvlink-vs-pci-e-nvidia-tesla-p100-gpus-openpower-servers/>

- Fielding, & Tyrer. (1980). HISTORY OF PENICILLIN. *The Lancet*, 315(8158), 43-44.
- Gillan, C., Harnett, N., Milne, E., Purdie, T., Wiljer, D., Jaffray, D., & Hodges, B. (2018). Professional Implications of Introducing Artificial Intelligence in Healthcare: An Evaluation using Radiation Medicine as a Testing Ground. *Journal of Medical Imaging and Radiation Sciences*, 49(1), 1-18. doi:10.1016/j.jmir.2018.02.006
- Grady, Denise. "The Drawn-Out Medical Degree." *The New York Times*, *The New York Times*, 1 Aug. 2014, www.nytimes.com/2014/08/03/education/edlife/the-drawn-out-medical-degree.html.
- http://icl.cs.utk.edu/projectsfiles/magma/pubs/74-gtc18_iterrefc_poster.pdf
- <http://radlogics.com/>
- Intel. (n.d.). The Story of the Intel® 4004. Retrieved from <https://www.intel.com/content/www/us/en/history/museum-story-of-intel-4004.html>
- iRobot. (n.d.). In IMDB. Retrieved from <https://www.imdb.com/title/tt0343818/>
- Kaplan, D. A. (2017, April 21). How Radiologists are Using Machine Learning. Retrieved from <http://www.diagnosticimaging.com/pacs-and-informatics/how-radiologists-are-using-machine-learning>
- Kaplan, J. (2015). Teaching Computers to Fish. In *Humans Need Not Apply: A Guide to Wealth and Work in the Age of Artificial Intelligence* (pp. 27-29). New Haven, Conn: Yale U.P.
- Kaplan, J. (2015). Teaching Computers to Fish. In *Humans Need Not Apply: A Guide to Wealth and Work in the Age of Artificial Intelligence* (pp. 30-31). New Haven, Conn: Yale U.P.
- Kelly, R.E. "SURGERY 100 YEARS AGO." *The Lancet* 229, no. 5936 (1937): 1361-363.
- Kennedy, B. (2016, October 18). Most Americans trust the military and scientists to act in the public's interest. Retrieved July 13, 2018, from <http://www.pewresearch.org/fact-tank/2016/10/18/most-americans-trust-the-military-and-scientists-to-act-in-the-publics-interest/>
- Kulkarni, P. (2012). Introduction to Reinforcement and Systemic Machine Learning. In *Reinforcement and Systemic Machine Learning for Decision Making* (IEEE Press series on systems science and engineering, pp. 3-4). Hoboken, NJ: John Wiley & Sons.
- Landi, H. (2016, December 1). IBM Unveils Watson-Powered Imaging Solutions at RSNA. Retrieved August 08, 2018, from <https://www.healthcare-informatics.com/news-item/analytics/ibm-unveils-watson-powered-imaging-solutions-rsna>
- Lipkin, M. (1984). Historical Background on the Origin of Computer Medicine. *Proceedings of the Annual Symposium on Computer Application in Medical Care*, 987-990.
- McDonald CJ, Weiner M, Hui SL. Deaths Due to Medical Errors Are Exaggerated in Institute of Medicine Report. *JAMA*. 2000;284(1):93-95. doi:10.1001/jama.284.1.93
- Medpac. (2017). June 2017 Report to the Congress: Medicare and the Health Care Delivery System (pp. 207-242) (United States, Congress, Medicare Payment Advisory Commission (U.S.)). Washington, DC: Medicare Payment Advisory Commission.
- Michtalik HJ, Yeh H, Pronovost PJ, Brotman DJ. Impact of Attending Physician Workload on Patient Care: A Survey of Hospitalists. *JAMA Intern Med*. 2013;173(5):376-377. doi:10.1001/jamainternmed.2013.1864

- Micro Semi. (n.d.). Peripheral Component Interconnect (PCI) Express PCIe Technology. Retrieved July 01, 2018, from <https://www.microsemi.com/company/technology/pci-express-pcie-technology>
- National Research Council (US) and Institute of Medicine (US) Board on Science, Technology, and Economic Policy; Aspden P, editor. Medical Innovation in the Changing Healthcare Marketplace: Conference Summary. Washington (DC): National Academies Press (US); 2002. 3, The Costs and Benefits of Medical Innovation. Available from: <https://www.ncbi.nlm.nih.gov/books/NBK220598/>
- Paluszek, M., & Thomas, Stephanie. (2017). MATLAB machine learning. New York, NY?]: Apress.
- Parker, M. (2014, October 20). Understanding Peak Floating-Point Performance Calculations. Retrieved July 07, 2018, from https://www.eetimes.com/author.asp?section_id=36&doc_id=1324326
- Riley, J. (2001). Rising life expectancy: A global history. Cambridge; New York: Cambridge University Press.
- Robinson, D. H., & Toledo, A. H. (2012). Historical Development of Modern Anesthesia. *Journal of Investigative Surgery*, 25(3), 141-149. doi:10.3109/08941939.2012.690328
- Rosenthal, E. (2017). The Age of Insurance. In *An American sickness: How Healthcare Became Big Business and How You Can Take it Back*. New York, NY: Penguin Press.
- Sato, K. Patterson, D. (2017, May 12). An in-depth look at Google's first Tensor Processing Unit (TPU) | Google Cloud Big Data and Machine Learning Blog | Google Cloud. Retrieved July 10, 2018, from <https://cloud.google.com/blog/big-data/2017/05/an-in-depth-look-at-googles-first-tensor-processing-unit-tpu>
- Smith, A., & Anderson, M. (2017, October 04). 2. Americans' attitudes toward a future in which robots and computers can do many human jobs. Retrieved July 28, 2018, from <http://www.pewinternet.org/2017/10/04/americans-attitudes-toward-a-future-in-which-robots-and-computers-can-do-many-human-jobs/>
- Stallings, W. (2016). Computer organization and architecture: Designing for performance (Tenth ed.). Boston: Pearson-Prentice Hall.
- Strickland, N. (2000). PACS (picture archiving and communication systems): filmless radiology. *Archives of Disease in Childhood*, 83(1), 82–86. <http://doi.org/10.1136/adc.83.1.82>
- Sullivan, T. (2017, April 19). Half of hospitals to adopt artificial intelligence within 5 years. Retrieved August 08, 2018, from <https://www.healthcareitnews.com/news/half-hospitals-adopt-artificial-intelligence-within-5-years>
- Sun, C., Okamoto, S., Hachiya, S., Yamada, T., & Takeuchi, K. (2016). Design guidelines of storage class memory/flash hybrid solid-state drive considering system architecture, algorithm and workload characteristic. *Consumer Electronics, IEEE Transactions on*, 62(3), 267-274.
- Takahashi, D. (2018, May 14). Nvidia's Jensen Huang on the White House's AI initiative. Retrieved July 07, 2018, from <https://venturebeat.com/2018/05/13/nvidias-jensen-huang-on-the-white-houses-ai-initiative/>
- Thackray, A., Brock, David, & Jones, Rachel. (2015). Moore's law: The life of Gordon Moore, Silicon Valley's quiet revolutionary. New York: Basic Books, a member of the Perseus Books Group.

- The Terminator. (n.d.). In IMDB. Retrieved from <https://www.imdb.com/title/tt0088247/>
- Thedoctors.com (Tech.). (2016, January 11). Retrieved July 24, 2018, from The Doctors Company website: https://www.thedoctors.com/siteassets/pdfs/risk-management/closed-claims-studies/10579_ccs-internalmed_nomarks_fr.pdf
- Wiederhold, Gio, McCarthy, John, & Feigenbaum, Ed. (1990). Arthur Samuel: Pioneer in machine learning. (obituary). *Communications of the ACM*, 33(11), 137.

Appendices

Appendix 1

Transcript: Phone Conversation at 11:15 P.M. on 08/08/2018 Interview time 28:55

- Hussain:
 - Hello how are you doing today.
- Amir Jalali:
 - I am doing well, apologies for being late, I put my daughter to bed and fell asleep on her bed, so my apologies.
- Hussain:
 - Ha, no issue, thank you again for agreeing to do this interview, I want to interview you about Artificial Intelligence, there are companies out there currently making A.I. products for medical use and wanted to know your thoughts on the matter so I have written questions I want to ask. And thank you again, I really appreciate it.
- Amir Jalali:
 - Can you give me an example of an Artificial Intelligence for medical?
- Hussain:
 - Um-there is are companies that make A.I. programs for medical use, an example is Radlogics, which makes an A.I. that diagnosis MRI's, CT-Scans, and X-Rays, that does it in the cloud. So, you take an image and you send they send the image into the cloud where it is computed, they strip the data and compute the image then reattach patient data to the image for an accurate diagnosis. Then it gives a diagnosis to the doctor. So, again thank you for doing this interview, if you do not mind I'm going to ask the first question.
- Amir Jalali:
 - Ok.
- Hussain Altamimi:
 - Ok, so are you ready?
- Amir Jalali:
 - Yes.

Questions

- Are you open to using an A.I. program to help you diagnose patients?
 - Yes, definitely. Especially in the field of radiology and radiology interpretation.
- Would you be willing to pay to use an Artificial Intelligence program in your practice?
 - Yes, I would be willing to pay.
- Would you be open to having your patients screened by an Artificial Intelligence Algorithm before meeting them?

- Yes, streamlining what patients would be optimally seen by certain specialists. I could see a concern about what is getting missed in the process and what is not being interpreted that the data does not show.
- Would you be willing to use an Artificial Intelligence program if it meant not having to refer a patient to another specialist?
 - Yes, I would not trust that currently all the time.
- What tasks or type of tasks could you see yourself shifting to an Artificial Intelligence program.
 - I could see some data analysis, interpretation of certain tests that do not require nuance. For example, there is interpretation of an EKG sometimes the data is correct, sometimes it is wrong, that radiology interpretation, human interpretation is enough prone to error, I could actually see A.I. being a good tool. Being able to scan medical history, quickly and thoroughly enough, at a more accurate degree than a physician would in a short clinical setting.
- What technological changes have you seen take place since you began practicing medicine and how have they changed your practice?
 - The biggest, clearly is everything that revolves around electronic medical systems, I have all the images from the radiology that I use now available in a digitize electronic system. So, I do not have to get films to my office, I can access everything immediately. So, I have instantaneous access about a patient. I am able to analyze the radiology data better, because I can manipulate the digital image better with contrast enhancement and things like that. Everything has been changed for the better.
- What changes would you expect to see in your practice if you were to include the use of an Artificial Intelligence program? For example, would you take on more patients, change your time and effort, work less, etc.
 - If it gave you the capacity to do so in a way that did not alter the patient experience dramatically, then I would see a greater number of patients, and possibly work less hours. It would give patients greater access to doctors because they could see more patients.
- Do you believe there is a possibility doctors may one day be replaced by Artificial Intelligence programs?
 - No,
- What advantages do you believe a human doctor has in diagnosis over an Artificial Intelligence program?
 - A human doctor at least at a point I can envision an A.I. program working is the ability to detect nuance information that is not just a data point. Sometimes it is what an individual says in response to a question that sometimes gives you more information than what they do say. Maybe a human physician will always have an advantage in how I envision it, is not absolute diagnosis, but more in the delivery in the care. For example, having to get a patient to lose weight in a sensitive matter, they

- will respond positively, how do you give information that they have cancer, how do you deal with parents in the case of childhood disease, that in our field is 50% of what we do. Data analysis, evaluation, and diagnosis is only a part of the practice, the diagnostic aspect of it is in the physical examination, some aspects can be reduced in easy data points. For example, a heart rhythm, but aspects for example an evaluation of the muscular skeletal system, this is not possible, these are limitations of doing remote diagnostic work. That is a limitation there as well. That is a point, I do not think artificial intelligence will be easy to replace.
- How would a diagnosis differing from yours by an Artificial Intelligence program affect your decision on a patient?
 - It would make me review my decision, to check the degree of confidence that I have in that decision, in the decision or the diagnosis that I made, make me review the possibilities an artificial intelligence program, would make me review them as well. I could see that in the radiology field as well very easily, I could easily see one missing something that the other one picks up, it expands your differential diagnosis.
 - What is the mental process that you go about when evaluating patients?
 - It is the evaluation of a patient in three aspects, one is in thorough history, which requires quite a bit of interaction with a patient. A lot of the questions you may not get verbally, of course much of it is told to you. The second is physical examination, the third is reviewing data, in my field a little bit less data review, not one thing is adequate enough, two out of three is better, but three out of three is what gives you the most accurate diagnosis.
 - Do you believe an Artificial Intelligence Algorithm can operate independently, without the participation of a doctor?
 - I think that there is some limited utility, you know there are things that I think are simple data analysis that are based on strictly on data alone, lab findings, radiology findings, that are independent of other data gathering, or independent of other interaction. Take for example, microbiology a patient comes in with a fever and they get cultures does not, and a culture grows this, and they can be potentially treated based on that. Sometimes it takes a person to take what kind of data does not fit. For example, in the microbiology example, a person comes in with a cough and fever, you could use just microbiology data to evaluate, sometimes however, it could be a containment that it would take someone to see. I think to a limited degree however it would be reasonable, especially if it increases access to some people, it just cannot replace fully access to a physician's work.

Appendix 2

Script:

Primary Care Physicians

Email:

Hello, My name is Hussain Altamimi, I am a researcher from the University Washington studying the potential impact of Artificial Intelligence in the medical field. As an independently practicing family and internal medicine physician, my team and believe you would have incredible insight on the future of medicine if Artificial Intelligence were to be introduced into the medical field. I would love to sit down for a short 30-minute interview to discuss your perceptions and expectations on the future of medicine and Artificial Intelligence. The interview will be confidential and no identifiable information will be released to the public. I have attached the interview questions to this email to help inform your decision on accepting this interview, any help would be greatly appreciated. If you have any questions, please feel free to respond by email or call (360) - 771 - 5949.

Thank you so much,

Phone Call Wrap:

Hello, My name is Hussain Altamimi and I am a researcher from the University of Washington studying the potential impact of Artificial Intelligence in the field of primary care medicine. I am calling to see if doctor _____ was open to conducting a short confidential 30-minute interview about how they see Artificial Intelligence effecting the Primary Care Medicine Field. I can send or drop off the interview questions to your office before the interview for the doctor to review. Again, any and all help would be appreciated.

Thank you so much,

Technology Companies

Email:

Hello, My name is Hussain Altamimi, I am a researcher from the University Washington conducting research on the future of Artificial Intelligence in the field of medicine. Currently, we are gathering data from expert interviews on the future and potential impacts of this industry and as one of the innovative companies leading advancements in the field of Artificial Intelligence we would love to borrow 30-minutes of your time to discuss the future of Artificial Intelligence in the field of healthcare. The interview will be confidential and no identifiable information will be released to the public, unless otherwise requested. I have attached the questions to this email to help inform your decision on accepting this interview, any amount of time would be greatly appreciated.

Thank you so much,

Phone Call Wrap:

Hello, my name is Hussain Altamimi and I am a researcher from the University of Washington studying the potential impact of Artificial Intelligence in the field of primary care medicine. I am calling to see if your company would be willing to participate in a short 30-minute interview to discuss the future of Artificial Intelligence in Primary Care Medicine.

Thank you so much,

Appendix 3

Interview Contact Sheet - Hussain Altamimi

07-30-2018

1. Hawthorne Hills Internal Medicine
 - a. 4026 NE 55th St Ste F Seattle, WA 98105 b/t 41st St & N 40th Ave
 - i. Notes: **Maybe - No**
 2. Edmonds Family Care
 - a. 6101 200th St SW #208, Lynnwood, WA 98036
 - i. Notes: **Maybe - No**
 3. Mill Creek Family Practice
 - a. 1025 153rd St. SE Suite 200 Mill Creek, WA 98012
 - i. Notes: **Maybe - No**
 4. Green Lake Primary Care
 - a. 6800 E Green Lake Way N, #200 | Seattle, WA 98115
 - i. Notes: **No**
 5. Upton Family Medicine
 - a. 221 4th Ave N, Edmonds, WA 98020
 - i. Notes: **No**
-

08-06-2018

1. Immediate Clinic,
 - a. Everett, 607 SE Everett Mall Way, Everett, WA 98208
 - i. Notes: Monday the 13th is when the MD comes back.
2. Providence Walk-in Care
 - a. Mill Creek, 12800 Bothell Everett Hwy #110, Mill Creek, WA 98208
 - i. Notes: **Maybe - No**
3. The Everett Clinic at Silver Lake
 - a. 1818 121st St SE, Everett, WA 98208
 - i. Notes: **Maybe - No**
4. The Everett Clinic at Mill Creek
 - a. 15418 Main St, Mill Creek, WA 98012
 - i. Notes: **Maybe - No**

5. Schmidt medical center, Mill Creek Family Practice,
 - a. 1025 153rd St SE #200, Mill Creek, WA 98012
 - i. Notes: **Maybe - No**
 6. Lake Serene Clinic
 - a. 3501 Shelby Rd, Lynnwood, WA 98087
 - i. Notes: **Maybe - No**
 7. Providence Family Medicine
 - a. Lynnwood, 2902 164th St SW, Lynnwood, WA 98087
 - i. Notes: **Maybe - No**
 8. The Everett Clinic
 - a. 1303 Pacific Ave, Everett, WA 98201
 - i. Notes: Amir Jalali **Yes (08-08-2018)**
-

07-30-2018

1. Viz A.I.
 - a.
 - i. press@viz.ai
 - b. Chris Mansi, CEO
 - c. Rose Petroff, personal assistant
 - i. Notes: **Yes (08-09-2018/08-16-2018, DELAYED)**
 2. Arterys
 - a. 51 Federal Street, San Francisco, CA 94107, USA
 - b. Name:
 - i. Notes: **No response**
 3. Radlogics
 - a. Cannot find address
- Notes: **No response**

Appendix 4

Dear Participant,

A University of Washington researcher is conducting a study on the future of Artificial Intelligence in the Primary Care Medicine Field and is requesting your participation. In this interview, we will ask you questions about your opinions and experiences related to this subject.

Your responses will be held in the strictest confidence. No personal data such as age, race, gender, or experience levels will be shared in a way that will allow anyone to identify you as a participant. We will protect participant privacy to the extent permitted by Washington state law and the Freedom of Information Act. We are doing this to allow you a chance to participate in a confidential and private manner with the most comfort.

Please note that the data from this study may be presented at an academic conference or published in a research journal. With regard to these presentations and publications, before attributing any statements to you, the research team will provide you a draft of any paragraphs in which quotes from or references to this interview are made. Should you wish to correct any quotations or other attributions, the authors will make these corrections before publication.

Participation in this study is **completely voluntary**, and you may feel free not to answer any or all of the questions. If at any time you do not wish to answer a question, you can simply indicate that preference to the researcher. Also, you may stop the interview at any time simply by indicating this preference to the researcher.

Signing this form will be interpreted as "informed consent" for your participation in this study. Refusal to participate will not result in any penalty or loss of benefits to which the participant is otherwise entitled. The interview should take approximately 30 minutes to complete.

Please note the interviewer will be using a voice recorder of this interview to help with the documentation of responses. These audio recordings will not be made public and be protected by 256-bit AES encryption in a secure location.

If you have any questions about the survey, please contact Hussain Altamimi at the University of Washington, Bothell: huss95@uw.edu.

You will be provided will a copy of this form upon request.

Thank you for your participation!

Signature of Participant



Date

8/14/18