

DEVELOPING DESIGN GUIDELINES FOR COMMERCIAL VEHICLE ENVELOPES ON URBAN STREETS

FINAL PROJECT REPORT

by

Edward McCormack, Ph.D.
Anne Goodchild, Ph.D.
Manali Sheth
University of Washington

David S. Hurwitz, Ph.D.
Hisham Jashami
Douglas P. Cobb, PE (VA, MD, FL), PTOE, RSP₁
Oregon State University

Sponsorship

Pacific Northwest Transportation Consortium (PacTrans)

for

Pacific Northwest Transportation Consortium (PacTrans)
USDOT University Transportation Center for Federal Region 10
University of Washington
More Hall 112, Box 352700
Seattle, WA 98195-2700

In cooperation with US Department of Transportation- Office of the Assistant Secretary for
Research and Technology (OST-R)



Disclaimer

The contents of this report reflect the views of the authors, who are responsible for the facts and the accuracy of the information presented herein. This document is disseminated under the sponsorship of the U.S. Department of Transportation's University Transportation Centers Program, in the interest of information exchange. The Pacific Northwest Transportation Consortium, the U.S. Government and matching sponsor assume no liability for the contents or use thereof.

Technical Report Documentation Page

1. Report No.	2. Government Accession No. 01701467	3. Recipient's Catalog No.	
4. Title and Subtitle Developing Design Guidelines for Commercial Vehicle Envelopes on Urban Streets		5. Report Date 02/15/2020	
		6. Performing Organization Code	
7. Author(s) Edward McCormack, 0000-0002-2437-9604; Anne Goodchild, 0000-0003-1595-0570; Manali Sheth, David S. Hurwitz, 0000-0001-8450-6516; Hisham Jashami, and Douglas P. Cobb		8. Performing Organization Report No. 2017-M-UW-2	
9. Performing Organization Name and Address PacTrans Pacific Northwest Transportation Consortium University Transportation Center for Region 10 University of Washington More Hall 112 Seattle, WA 98195-2700		10. Work Unit No. (TRAIS)	
		11. Contract or Grant No. 69A3551747110	
12. Sponsoring Organization Name and Address United States of America Department of Transportation Research and Innovative Technology Administration		13. Type of Report and Period Covered Research-Applied	
		14. Sponsoring Agency Code	
15. Supplementary Notes Report uploaded at www.pacTrans.org			
16. Abstract <p>This report presents research to improve the understanding of curb space and delivery needs in urban areas. Observations of delivery operations to determine vehicle type, loading actions, door locations, and accessories used were conducted. Once common practices had been identified, then simulated loading activities were measured to quantify different types of loading space requirements around commercial vehicles. This resulted in a robust measurement of the operating envelope required to reduce conflicts between truck loading and unloading activities with adjacent pedestrian, bicycle, and motor vehicle activities.</p> <p>A bicycling simulator experiment examined bicycle and truck interactions in a variety of commercial vehicle loading zone (CVLZ) designs. The experiment was completed by 50 participants. The bicycling simulator collected data regarding a participant's velocity, lane position, and acceleration. Three independent variables were included in this experiment: pavement marking (no CVLZ, minimum CVLZ, or recommended CVLZ), courier position (none, behind the vehicle, on the driver's side), and accessory (none or a hand truck).</p> <p>The results support the development of commercial loading zone design recommendations that will allow our urban street systems to operate more efficiently, safely, and reliably for all users.</p>			
17. Key Words Commercial Vehicles, Loading Zones, Bicycle Simulator, Street Design, Freight Operations		18. Distribution Statement No restrictions.	
19. Security Classification (of this report) Unclassified.	20. Security Classification (of this page) Unclassified.	21. No. of Pages	22. Price NA

Form DOT F 1700.7 (8-72)

Reproduction of completed page

authorized

Table of Contents

List of Abbreviations	xi
Acknowledgments	xii
Executive Summary	xiii
Chapter 1. Introduction	1
Chapter 2. Literature Review	5
2.1 Introduction.....	5
2.2 Growth of Urban Freight and Commercial Vehicles in the United States	5
2.3 Commercial Vehicle Load Zones Design Standards/Guidelines – Current Practices	5
2.4 CVLZ Design Standards/Guidelines for Selected Jurisdictions	8
2.5 Americans with Disabilities Act (ADA) Design Standards – An Example.....	9
2.6 Conclusion	9
Chapter 3. Field Observation Research Method	11
3.1 Introduction to Field Observations	11
3.2 Field Observation Research Method.....	11
3.3 Data Collection Form Categories.....	11
3.3.1 Delivery Location, Date, and Time.....	11
3.3.2 Commercial Vehicle Characteristics.....	11
3.3.3 Delivery Company	12
3.3.4 Vehicle Classification	12
3.3.5 Driver and Passenger Entry/Exit Door Type	12
3.3.6 Cargo Compartment Door Location	12
3.3.7 Cargo Door Type	12
3.3.8 Exiting/Entering Commercial Vehicle Behavior	12
3.3.9 Vehicle Exit/Entry Points	12
3.3.10 Accessories Used and Accessory Path.....	13
3.3.11 Accessories Used	13
3.3.12 Accessory Path – Description at Rest and In Use.....	13
3.3.13 Courier Path to Access Cargo – Movements Described Around Commercial Vehicle	13
3.3.14 Delivery Characteristics and Goods Described	13
3.3.15 Number of Couriers	14
3.3.16 Goods Described.....	14
3.3.17 Courier Behavior in Response to the Built Environment (Street, Road, and Land-Use Characteristics)	14

3.3.18 Description of Unique Movements Observed.....	14
Chapter 4. Field Observations Results.....	15
4.1 Major Takeaways from the Field Observations.....	15
4.2 Observed Commercial Vehicle Classifications	15
4.3 Number of Delivery Company Staff.....	15
4.4 Driver and Passenger Door Type.....	15
4.5 Cargo Compartment Location.....	16
4.6 Lift Gate Presence.....	16
4.7 Accessory Type.....	16
4.8 Side of Vehicle Used During Loading/Unloading.....	16
Chapter 5. Simulated Deliveries	19
5.1 Introduction.....	19
5.2 Data Collection Method.....	19
Step 1 – Closed Vehicle Footprint.....	20
Step 2 – Open Vehicle Footprint	20
Step 3 – Active Vehicle Footprint (Courier and Accessory)	20
Step 4 – Interview	21
5.3 Schematic Key	21
5.4 University of Washington (UW) Moving Services Simulation.....	21
Step 1- UW – 16-Footer Closed Vehicle Footprint	22
Step 2 - UW – 16-Footer Open Vehicle Footprint.....	23
Step 3 - UW – 16-Footer Active Vehicle Footprint.....	24
Step 1 - UW – 24-Footer Closed Vehicle Footprint	25
Step 2 - UW – 24-Footer Open Vehicle Footprint.....	26
Step 3 - UW – 24-Footer Active Vehicle Footprint.....	27
Step 4 – UW Interview	29
5.5 United Postal Service (UPS) Simulation	30
Step 1 - UPS - Package Car Closed Vehicle Footprint.....	30
Step 2 - UPS - Package Car Open Vehicle Footprint	31
Step 3 - UPS - Package Car Active Vehicle Footprint	31
Step 1 - UPS – 24-Footer Closed Vehicle Footprint.....	33
Step 2- UPS – 24-Footer Open Vehicle Footprint.....	34
Step 3 - UPS 24-Footer Active Vehicle Footprint.....	35
Step 4 – UPS Interview	36
5.6 Charlie’s Produce Simulation.....	39

Step 1 - Charlie's Produce - Delivery Van Closed Vehicle Footprint.....	40
Step 2 - Charlie's Produce - Delivery Van Open Vehicle Footprint	41
Step 3 - Charlie's Produce - Delivery Van Active Vehicle Footprint	42
Step 1 - Charlie's Produce - Box Truck with Ramp Closed Vehicle Footprint.....	43
Step 2 - Charlie's Produce - Box Truck with Ramp Open Vehicle Footprint	44
Step 3 - Charlie's Produce - Box Truck with Ramp Active Vehicle Footprint	45
Step 1 - Charlie's Produce - Box Truck with Lift Closed Vehicle Footprint	46
Step 2 - Charlie's Produce - Box Truck with Lift Open Vehicle Footprint.....	48
Step 3 - Charlie's Produce - Box Truck with Lift Active Vehicle Footprint.....	49
Step 4 – Charlie's Produce Interview	50
5.7 Summary of Research Findings from Simulations	52
5.7.1 Driver and Passenger Door Wingspan/ Widest Dimensions of a Vehicle.....	53
5.7.2 Delivery Type (Assisted or Unassisted)	54
5.7.3 Cargo Door Type at the Back End of the Vehicle	57
5.8 Summary.....	57
Chapter 6. Bicycle Simulator Experiment.....	61
6.1 Method.....	61
6.1.2 Experimental Equipment	61
6.1.2 Experimental Design.....	65
6.1.3 Bicycling Simulator Experimental Protocol	68
6.2 Results.....	71
6.2.1 Participants.....	71
6.2.2 Bicycle Performance.....	77
Chapter 7. Conclusions.....	87
7.1 Data Collection	87
7.2 Bicycle Simulator Findings.....	87
7.3 Recommendations.....	88
7.4 Limitations	89
7.5 Future Work	90
References	91
Appendix 1. Field Observations – Example Data Collection Form	95
Appendix 2. Vehicle Classification Description	97
Appendix 3. Images of Delivery Accessories	101
Appendix 4. Simulation Data form	105
Appendix 5. Driver Interview Form.....	109

List of Figures

Figure 2.1 Commercial vehicle loading zones signage (SDOT 2015a).....	6
Figure 2.2 Urban freight vehicle defined and dimensions (NACTO 2016).....	7
Figure 5.1 Simulation measurement key.....	21
Figure 5.2 UW 16-footer closed footprint (left) 16-footer open footprint (right).....	22
Figure 5.3 UW 16-footer schematic: closed vehicle measurement	22
Figure 5.4 UW 16-footer schematic: open vehicle measurements	23
Figure 5.5 UW 16-footer schematic: active vehicle measurements.....	24
Figure 5.6 UW 24-footer schematic: closed vehicle measurements	25
Figure 5.7 UW 24-footer: open vehicle measurements	26
Figure 5.8 UW 24-footer active footprint simulation	27
Figure 5.9 UW 24-footer: active vehicle measurements.....	28
Figure 5.10 UPS closed footprint vehicle simulation	30
Figure 5.11 UPS package car schematic: closed vehicle Measurements.....	30
Figure 5.12 UPS package car schematic: delivery movements measurements	31
Figure 5.13 UPS package car accessory schematic: accessories measurements	32
Figure 5.14 UPS 24-ft box truck schematic: closed vehicle measurements	33
Figure 5.15 UPS 24-ft box truck schematic: open vehicle measurements.....	34
Figure 5.16 UPS 24-ft box truck schematic: delivery movements measurements	35
Figure 5.17 Charlie’s Produce delivery van: closed vehicle measurements.....	40
Figure 5.18 Charlie’s produce delivery van: open vehicle measurements	41
Figure 5.19 Charlie’s Produce delivery van: delivery movements measurements	42
Figure 5.20 Charlie’s Produce delivery van: accessories measurements.....	42
Figure 5.21 Charlie’s Produce box truck with ramp: closed vehicle measurements	43
Figure 5.22 Charlie’s Produce box truck with ramp: open vehicle measurements.....	44
Figure 5.23 Charlie’s Produce box truck with ramp: open vehicle measurements - ramp profile	45
Figure 5.24 Charlie’s Produce box truck with ramp: delivery movements measurements	46
Figure 5.25 Refrigerated box truck with lift gate at Charlie's Produce	47
Figure 5.26 Charlie’s Produce box truck with lift: closed vehicle measurements.....	47
Figure 5.27 Charlie’s Produce box truck with lift: open vehicle measurements	48
Figure 5.28 Charlie’s Produce box truck with lift: delivery movements measurements.....	49
Figure 5.29 Location for width of truck measurement	54
Figure 5.30 Locations for operating envelope measurements	54
Figure 6.1 FHWA vehicle classification framework (FHWA, 2014).....	62
Figure 6.2 Operator workstation for the bicycling simulator. <i>Left</i> : Real-time monitoring of the simulated environment. <i>Right</i> : A researcher designing an experiment in SimCreator.....	63
Figure 6.3 Simulated environment in the OSU driving simulator. <i>Left</i> : Participant’s perspective. <i>Right</i> : A researcher testing the environment.....	63
Figure 6.4 Screenshot of the three views from SimObserver. <i>Left</i> : Simulated scene as projected on the screen. <i>Center</i> : View of the driver’s upper body and hands on the handlebar. <i>Right</i> : View of the entire simulator platform.	64
Figure 6.5 Example of a) no loading zone, b) minimum loading zone size, and c) maximum loading zone	67
Figure 6.6 Layout of Grid 1	67

Figure 6.7 Calibration ride in simulation	70
Figure 6.8 Screenshot of the <i>Data Distillery</i> software interface.....	71
Figure 6.9 Participants' experience with riding in the bike lane with commercial vehicle conflict.....	74
Figure 6.10 Participants' most comfortable scenario.....	75
Figure 6.11 Participants' experience with obstruction in the bike lane while riding.....	75
Figure 6.12 Participants' decision to make similar action to avoid hazards in the real world	76
Figure 6.13 Participants' typical responses to avoiding obstructions in the bike line.....	77
Figure 6.14 Primary effects plot of the selected factors on mean lateral position.....	80
Figure 6.15 Two-way interactions of treatment variables on mean lateral position: 1) two-way interactions plot between loading zone size and courier position, b) two-way interactions plot between loading zone size and accessories, and c) two-way interactions plot between courier position and accessories	81
Figure 6.16 Bicyclists' lateral position at different loading zone sizes with a courier on the side.....	83
Figure 6.17 Primary effects plot of the selected factors on mean speed.....	85
Figure 6.18 Two-way interactions plot of treatment variables on participants' mean speed: a) two-way interactions between loading zone size and courier position, b) two-way interactions between loading zone size and accessories, and c) two-way interacts between courier position and accessories.....	86

List of Tables

Table 5.1 UW 16-footer: closed vehicle measurements	22
Table 5.2 UW 16-footer: open vehicle measurements	24
Table 5.3 UW 16-footer: active vehicle measurements	25
Table 5.4 UW 24-footer: closed vehicle measurements	26
Table 5.5 UW 24-footer: open vehicle measurements	27
Table 5.6 UW 24-footer: active vehicle measurements	28
Table 5.7 UPS package car: closed vehicle measurements.....	31
Table 5.8 UPS package car: delivery movements and accessories measurements	32
Table 5.9 UPS 24-ft box truck: closed vehicle measurements.....	33
Table 5.10 UPS 24-foot box truck: open vehicle measurements.....	34
Table 5.11 UPS 24-ft box truck: delivery movements measurements	35
Table 5.12 Charlie’s Produce delivery van: closed vehicle measurements	40
Table 5.13 Charlie’s Produce delivery van: open vehicle measurements.....	41
Table 5.14 Charlie’s Produce delivery van: delivery movements and accessories measurements.....	42
Table 5.15 Charlie’s Produce box truck with ramp: closed vehicle measurements.....	44
Table 5.16 Charlie’s Produce box truck with ramp: open vehicle measurements	45
Table 5.17 Charlie’s Produce box truck with ramp: delivery movements measurements.....	46
Table 5.18 Charlie’s Produce box truck with lift: closed vehicle measurements	48
Table 5.19 Charlie’s Produce box truck with lift: open vehicle measurements.....	48
Table 5.20 Charlie’s Produce box truck with lift: delivery movements measurements	50
Table 5.21 Truck footprint summary in centimeters (inches).....	53
Table 5.22 Driver/passenger door width minimum and maximum (inches).....	54
Table 5.23 Unassisted workable minimum and maximum (Inches).....	55
Table 5.24 Hand truck assisted delivery workable minimum and maximum (inches)	55
Table 5.25 Pallet jack assisted delivery (inches).....	56
Table 5.26 Lift gate minimum/maximum with pallet jack (inches).....	56
Table 5.27 Ramp minimum with and without hand truck (inches).....	57
Table 5.28 Back end door type door minimum (inches).....	57
Table 5.29 Envelope dimensions in centimeters (inches).....	58
Table 6.1 Experimental factors and levels	65
Table 6.2 Scenarios	66
Table 6.3 Participant bicycling habits	72
Table 6.4 Participant demographics	72
Table 6.5 Mean and standard deviation of lateral position (m) at the independent variable level.....	78
Table 6.6 Summary of estimated models for lateral position	79
Table 6.7 Mean and standard deviation of speed (m/sec) at independent variable level.....	83
Table 6.8 Summary of estimated models for speed (m/sec)	84

LIST OF ABBREVIATIONS

PacTrans: Pacific Northwest Transportation Consortium

WSDOT: Washington State Department of Transportation

CVLZ: Commercial vehicle load zone

UPS: United Postal Service

CP: Charlie's Produce

UW: University of Washington

OSU: Oregon State University

ACKNOWLEDGMENTS

This research project required a comprehensive and deep understanding of a courier's unique needs during the vehicle loading/unloading process in urban areas. The research team would like to thank the University of Washington's Moving Services team, and the Urban Freight Lab Members, UPS, and Charlie's Produce for taking the time to share their expertise and experience. Their participation in this research project added great value and understanding to the micro activities that occur in urban deliveries.

In addition, the research team would like to thank Siqi Lu for volunteering her time to attend a simulation and assist with recording movements and measurements, and Dylan Horne for his contributions to the conceptual design of the bicycling simulator experiment.

EXECUTIVE SUMMARY

As urban populations and freight activities increase, there is continued pressure for multiple modes to share urban streets and compete for curb space. Cities are recognizing curb space as valuable public real estate that must be better understood and designed in order to improve the quality of life for residents and the transportation systems of cities.

Current commercial vehicle load zones (CVLZ) are not well designed to accommodate safe, efficient, and reliable deliveries. Commercial vehicles using urban curbside loading zones are not typically provided with a consistent envelope, or a space adjacent to the vehicle, allocated for deliveries. While completing loading and unloading activities, drivers are required to walk around the vehicle, extend ramps and handling equipment, and maneuver goods; these activities require space around the vehicle. But these unique space needs of delivery trucks are not commonly acknowledged by or incorporated into current urban design practices. Because of this lack of a truck envelope, drivers of commercial vehicles are observed using pedestrian pathways and bicycling infrastructure for unloading activities as well as walking in traffic lanes. These actions put themselves, and other road users in direct conflict and potentially in harm's way.

This project improves our understanding of curb space requirements and delivery needs in urban areas. The research approach involved the observation of delivery activities operations to measure the envelope required for different vehicle types, loading actions, door locations, and accessories. Once the envelope had been determined, then a simulator was used.

Common loading and unloading practices and where freight activities occurred in relationship to trucks (sides, back, or front) were initially identified by observing 25 curbside deliveries in urban Seattle. The research team next collaborated with three delivery companies with active operations in urban areas. These companies provided access to their facilities, nine different urban delivery vehicles, and a variety of loading accessories. The research team initially recorded the commercial vehicle's closed vehicle footprint without any possible extensions engaged. Next the open vehicle footprint was measured when all vehicle parts such as doors, lift gates, and ramps were extended for delivery operations. Finally, the active vehicle footprint was recorded as the companies' drivers simulated deliveries, which allowed the research team to observe and precisely measure driver and accessory paths around the vehicle.

This process resulted in robust measurements—tailored to different types of truck configurations, loading equipment and accessories—of the operating envelope around a

commercial vehicle. These measurements, added to the footprint of user-selected delivery truck sizes, provide the envelope needed to reduce conflicts between truck loading and unloading activities and adjacent pedestrian, bicycle, and motor vehicle activities.

A bicycling simulator experiment examined bicycle and truck interactions in a variety of CVLZ designs. The experiment was successfully completed by 50 participants. The bicycling simulator collected data regarding a participant's velocity, lane position, and acceleration. Three independent variables were included in this experiment: pavement marking (no CVLZ, the minimum CVLZ, or the recommended CVLZ), courier position (none, behind the vehicle, on the driver's side), and accessory (none or a hand truck). Several summary observations resulted from the bicycling simulator experiment:

- A bicyclist passing by a no loading zone (with a truck obstructing the bike lane) or a minimum loading zone (with a truck next to the bike lane without a buffer) had a significantly lower speed than a bicyclist passing a preferred loading zone (with an extra buffer). A smaller loading zone decreased bicyclists' mean speed, and a courier exiting on the driver side of the truck caused the lowest mean speed.
- A courier on the driver's side of the truck increased bicyclists' mean lateral position, with no CVLZ causing bicyclists' greatest divergence from the right edge of the bike lane. Consequently, bicyclists shifted their position toward the left edge of bike lane and even into the adjacent travel lane. Moreover, some bicyclists used the crosswalk to avoid the delivery truck and the travel lane.
- In the presence of a courier on the driver's side of the truck, bicyclists tended to be most disrupted by the minimum CVLZ because they tended to depart from the bike lane toward the adjacent vehicular travel lane.
- When bicyclists approached a delivery vehicle parked in the bicycle lane, they had to choose between using the travel lane or the sidewalk. About one third of participants decided to use the sidewalk.

From our results, commercial loading zone best practice envelope recommendations can be developed that will allow our urban street systems to operate more efficiently, safely, and reliably for all users

CHAPTER 1. INTRODUCTION

There is continued pressure for multiple modes to share urban streets and compete for curb space as urban populations and freight activities increase. Cities are recognizing curb space as valuable public real estate that must be better understood, managed, and designed in order to improve the quality of life for residents and the transportation systems of cities.

Cities are responsible for strategizing how best to manage, regulate, and design curb space for different transportation modes and activities, including commercial vehicle parking and urban deliveries. These strategies are complex because they include a wide range of stakeholders and are further compounded by well accepted urban planning policies (such as Smart Growth and Complete Streets) that support compact development, a mixture of land uses, and a range of feasible transportation options that promote and facilitate modes of travel other than the automobile – e.g., transit, bicycles, and walking (NATCO 2019, Smart Growth America 2019). By adopting a Complete Streets policy, communities direct their transportation planners and engineers to routinely design and operate the entire right of way to enable safe access for all users, regardless of age, ability, or mode of transportation. Although these policies are well intended, current application standards have significant gaps that do not fully support the unique infrastructure and design needs of freight activity and urban goods deliveries.

Previous studies and observations by the research team found that curb use by commercial vehicles is not aligned with designated curb allocation, and current allocation is not spatially allocated according to demand (SCTL 2019, Goodchild et al 2018, Wygonik et al 2015). Common actions that reflect the limitations of curb space design for deliveries include commercial vehicles parking on sidewalks and in bike lanes and turn lanes, loading ramps and lift gates blocking crosswalks and sidewalks, and the staging of freight in locations that impede bike and pedestrian movements. These issues are more notable in certain corridors with a high demand for deliveries, but this is not reflected in the street design or design of the loading spaces for commercial vehicles in these corridors. These problems occur because commercial vehicles using designated loading zones are not allocated an envelope, or space adjacent to the vehicle, to accommodate loading and unloading activities.

When performing delivery activities, couriers (i.e., delivery vehicle drivers and helpers) are required to walk around the vehicle, extend ramps and handling equipment, and maneuver goods; all these activities require space around the vehicle beyond the dimensions of the vehicle

itself. A parallel can be drawn with parking for disabled drivers, which allocates an extra buffer next to a disabled parking space to allow a wheelchair to exit/enter the vehicle. However, unlike disabled parking, trucks are typically not allocated this buffer space, and as a result of these design insufficiencies, couriers undertake high-risk behaviors.

In obstructing pedestrian pathways and bicycle infrastructure to complete deliveries, couriers' actions create uncertainty, disrupt the predictable flow of traffic, and put the driver and other road users in direct conflict and, ultimately, in harm's way. While North American data are unavailable, studies in the United Kingdom found that "every year, about 70 people are killed and 2000 seriously injured in accidents involving vehicles in and around workplaces. A significant number of these occur during deliveries and collections" (Health and Safety Executive, 2019).

Because of these design limitations, drivers of commercial vehicles and couriers are observed using and obstructing pedestrian pathways and bicycle infrastructure to complete deliveries. These actions create uncertainty and disrupt the predictable flow of traffic. As a result, they put the driver and other road users in direct conflict and ultimately, in harm's way. Currently, there are no explicit commercial vehicle load zone (CVLZ) design standards in the United States that incorporate the functional design elements that a commercial vehicle would need to load and unload.

These observations and discussions about urban deliveries and CVLZs motivated this research project. The University of Washington (UW) and Oregon State University (OSU) collaborated for this project in order to leverage their unique expertise in systematically observing urban deliveries and designing driving and bicycling simulations.

The goal of this research project was to understand and provide the following:

- the minimum operating space required during urban loading/unloading activities around a commercial vehicle through observed and simulated urban deliveries,
- the impacts of commercial vehicle loading and unloading activities on safe and efficient pedestrian and bicycle operations in a shared urban roadway environment using a bicycling simulator, and
- design guidelines for commercial vehicle envelopes on urban streets.

This information will support better roadway and load zone design guidelines, which will allow urban street systems to operate more efficiently, safely, and reliably for all users.

This report covers the following:

- Literature review – A summary of the growth of commercial vehicles in the United States, commercial load zone design guidelines, the impacts of Smart City and Complete Street policies on commercial load zones, and ADA parking standards.
- Field observations – A summary of the activities and movements of 25 urban deliveries observed in Seattle, Washington.
- Simulated deliveries – Measurements of courier driver and accessory movements around a commercial vehicle.
- Workable range for an operating envelope - analysis and results.
- Simulator experiments – Tests of alternative scenarios using participants and the OSU Bicycling Simulator.
- Analysis of bicycle simulator experimental results – Recorded and analyzed data involving instantaneous velocity, lateral position, and acceleration/deceleration.

CHAPTER 2. LITERATURE REVIEW

2.1 Introduction

The purpose of the literature review was to briefly review freight trends in urban areas and to explore current standards for designing commercial vehicle load zones (CVLZs). The literature review revealed that there is little oversight of and few regulations regarding design considerations for CVLZs, and discussions about well-designed CVLZs with sufficient operating envelopes lack clear policies, procedures, and methods for standardized CVLZ design guidelines.

2.2 Growth of Urban Freight and Commercial Vehicles in the United States

The need for freight delivery loading space is exacerbated by increases in urban populations, e-commerce, and home deliveries. Freight infrastructure faces increasing pressure as online shopping becomes more prevalent. In the United States, on average, e-commerce has grown by about 15 percent annually since 2010, and in 2018 e-commerce accounted for more than 40 percent of total retail growth (SCTL 2018, US Census 2019). The U.S. Census Bureau defines urbanized areas as places with 50,000 people or more, and according to the 2010 Census, 71.2 percent of the U.S. urban population was considered to be in an urbanized area (City Lab 2012). As urban populations continue to rise, so do freight volumes in order to fulfill their needs and desires. For example, in Seattle, the population is expected to grow by an additional 120,000 by 2035, and as a result, freight volumes are expected to increase by 60 percent (SDOT 2016).

2.3 Commercial Vehicle Load Zones Design Standards/Guidelines – Current Practices

A commercial vehicle load zone (CVLZ) is curb space designated for commercial vehicles to load/unload goods for a maximum specified amount of time, and this zone typically requires payment or a valid CVLZ permit (SDOT 2015a).

Cities across the United States have various rules and regulations for these zones, but they can be generalized to include a paid permit and signage to indicate the constraints within the loading zone. Figure 2.1 is an example of a type of CVLZ sign in Seattle, Washington. (To give a sense of the scale required for this system, the City of Seattle has approximately 460 CVLZs, 150 of which are located in downtown Seattle (City of Seattle, 2016)). In addition, there are no national standards for curb paint. Different cities have different policies regarding curb paint, but in some cities such as Seattle and San Francisco, yellow curb paint indicates activities that include, but are not limited to, freight loading/unloading activity (SDOT 2019, SMFTA 2019)

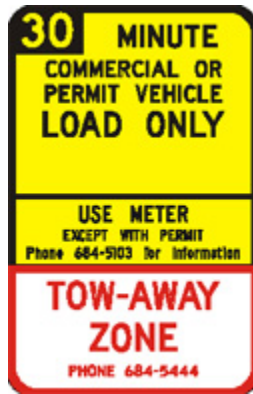

Figure 2.1 Commercial vehicle loading zones signage (SDOT 2015a)

It is important to note that within the freight trucking industry, there is no universal term that describes the space required around the vehicle for loading/unloading activities. Loading zone, truck-only load zones, commercial vehicle load zones, user envelope, and truck parking spaces are interchangeably used to generally describe designated truck parking and loading/unloading areas.

There is minimal information about CVLZ design and envelope requirements in the major geometric, traffic control, and street design guidebooks used by planners and engineers. The Manual on Uniform Traffic Control Devices (MUTCD 2012), a commonly used resource with national standards for roadways in the United States, includes detailed information about appropriate signage and grades for commercial vehicles but does not include clear standards for the design and dimensions of a CVLZ.

In the American Association of State Highway and Transportation Officials document *A Policy on Geometric Design of Highways and Streets* (AASHTO 2011), guidelines are suggested for urban parking lanes. These include a width sufficient to accommodate delivery vehicles and serve as a bicycle route, allowing bicyclists to maneuver around a vehicle's open door. The length of curb space allocated to each parking spot is not included.

The National Association of City Transportation Officials (NACTO 2019) is a non-profit association of major North American cities that publishes design guidelines for various urban planning elements and modes such as bikes, transit, and freight. NACTO acknowledges that the operational envelope required for comfortable and safe movements is different for all modes, and that freight requires additional space for hand and cart movement (NACTO 2016a). One of the

freight delineations is for *commercial vehicles and light trucks*, which are defined as “trucks generally used for carrying goods from ex-urbanized logistic centers to the city.” They are bigger in scale than motorized personal vehicles but do not require wider corner radii or bigger lanes. NACTO identifies the general dimensions of commercial vehicles and light trucks as 7 to 10 m (23 to 33 ft) long and 2 m (6.5 ft) wide (figure 2.2). NACTO also recommends that box trucks with a width of 2.4 m (8 ft) have a parking spot that is 3.4 m (11 ft) wide to incorporate the buffer space required for the door zone (NACTO 2016b). Although NACTO recognizes that additional space is required for freight parking to support freight loading/unloading activities, there is no additional information about the length of a commercial vehicle parking spot.

Commercial Vehicles and Light Trucks

These trucks are generally used for carrying goods from ex-urbanized logistic centers to the city. They are bigger in scale compared to motorized personal vehicles but do not require wider corner radii or bigger lanes.

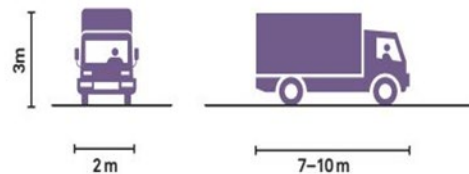

Figure 2.2 Urban freight vehicle defined and dimensions (NACTO 2016)

A study that used focus groups to learn from truck drivers about urban deliveries found that an impediment to urban freight activity was loading areas with insufficient space. The drivers recommended that curb space be at least 30 ft (9 m) long (Pivo et al 2002).

One of the few reports to explore truck access and parking, “Truck Movement and Access in Urban Areas,” noted that if traffic engineers considered the unique needs of urban freight in their practice, then the transportation ecosystem at large would improve (Ogden 1991). A section on load zones addressed the problems of on-street load zones, which included inconvenient location, insufficient number, and poor design and layout (e.g., with the potential for collisions between vehicles and roadside objects such as poles, verandas, and street lights). Although this article did not identify ideal on-street commercial vehicle parking dimensions, it included recommended minimum dimensions for loading bays, which could be used as a proxy for on-street commercial vehicle load zone dimensions:

- Light rigid two-axle truck: length 21 ft 8 in, width 6 ft 10 in, and wheelbase 12 ft 1 in.
- Heavy rigid three-axle truck: length 36 ft 0 in , width 7 ft 3 in, wheelbase (to midpoint of rear axles) 18 ft 1 in.

- Articulated truck with three-axle tractor: overall length 55 ft 9 in, width 8 ft 2 in. tractor wheelbase 12 ft 2 in., kingpin to midpoint of trailer axles 28 ft 3 in.

2.4 CVLZ Design Standards/Guidelines for Selected Jurisdictions

Several municipal and state freight plans were reviewed to explore how a few jurisdictions have addressed CVLZ design. A multimodal long-range transportation plan published in Washington D.C., *Move DC, Parking and Curbside Management Element*, focused on curbside parking (District Department of Transportation 2014). In the District of Columbia, a commercial vehicle is defined as “any vehicle with more than three wheels that is greater than 22 feet in length, or that is used or maintained for transporting freight, merchandise, or other commercial loads or property.” As a loading zone strategy, is the plan suggested to “lengthen loading zones to 100 feet wherever possible.” No additional information is provided regarding the width of the loading zone.

Portland, Oregon, published “Designing for Truck Movements and Other Large Vehicles in Portland” (City of Portland 2008). This guidebook was designed for planners, elected officials, engineers, and other decision makers who influence urban design and included a discussion of design considerations, an explanation of truck operating requirements, and a tool kit of potential design solutions. The purpose of these guidelines was to continue to improve the safety and accessibility of city (owned) streets for all users. A section, dedicated to street design considerations included a list of considerations about designs items such as curb cuts, ideal placement of a curb load zone, and more. However, there was no information about the minimum/maximum operating envelope for a CVLZ.

The Washington State Department of Transportation Design Manual is a resource for engineers, designers, and all other participants in state projects to understand design considerations and safety for “motorists, freight haulers, transit, pedestrians, and bicyclists” (WSDOT 2017). The Design Manual acknowledges that freight loading areas must be designed to “consider both the delivery vehicle size and how the vehicle loading/unloading is done.” It tells users to “Consult with business owners and freight carriers to locate and configure the freight loading areas.” This Manual does not recommend design or dimensions for CVLZs.

The Seattle Department of Transportation (SDOT) outlined its strategic vision for transportation in two plans: Move Seattle 2015 (SDOT 2015b) and the City of Seattle Freight Master Plan (SDOT 2016). Both these plans included and highlighted the role of freight in

Seattle's operations as a city. Although the plans illuminated the many challenges associated with freight in Seattle, such as managing curb space, setting parking rates, modifying streets into complete streets, and incorporating high tech solutions, these plans did not include any discussions about improving freight parking design standards to include more functional operating envelopes for commercial vehicles. A section in Move Seattle focused on how streets can work for all users, and although it included freight, it excluded the operating space required for comfortable and low-risk freight deliveries. It noted, "...commercial truck loading areas provide space on busy streets for delivery trucks. Enabling businesses to reliably send and receive goods ensures the products you want are there when you arrive" (SDOT 2015b). The Seattle Freight Master plan aimed to summarize the "unique characteristics, needs, and impacts of freight mobility in Seattle" (SDOT 2016). The plan discussed geometric improvements for freight by considering turning radii or widening lanes so that freight can maneuver more comfortably, but the challenges associated with loading and unloading freight in the last mile were not acknowledged.

2.5 Americans with Disabilities Act (ADA) Design Standards – An Example

The operating envelope suggested for freight loading and unloading activities is similar to the aisle required for ADA accessible parking spaces. The U.S. Department of Justice publishes and regularly updates the ADA Design Guide. Two accessible parking spaces are outlined in the Guide; one for cars and one for vans. These accessible parking spaces support the primary goal of having an unobstructed path of travel for those with special mobility needs.

ADA accessible car spots have an aisle at least 5 feet wide, while an accessible van spot must have an aisle 8 feet wide. This aisle gives passengers more maneuvering space while entering or leaving the vehicle. It is wide enough to accommodate any lifts, ramps, or additional movement space required to comfortably and safely access the vehicle or sidewalk. The process that was used to create these standards is not clear.

2.6 Conclusion

The literature review did not find direct acknowledgment that urban freight activities require envelopes around trucks to support urban load and unload activities. The standard design sources and manuals that support planners and engineers responsible for installing transportation infrastructure were found to address the space required for parking trucks but did not account for

the envelope needed around that parked truck that is necessary for safely and effectively loading and unloading goods.

Guidebooks that outline standards for highway, roadway, and on-street parking were found to include a range of information and measurements on turning radii, sight distance, stopping distance, off-peak deliveries, use of alleys, and more. However, the dimensions and design elements of an on-street CVLZ were not discussed at length or outlined in any of the literature reviewed for this research project.

CHAPTER 3. FIELD OBSERVATION RESEARCH METHOD

3.1 Introduction to Field Observations

The purpose of the field observations was to capture current delivery practices in Seattle and examine how those deliveries were conducted and how delivery operations were affected by both delivery characteristics and surrounding infrastructure. This qualitative study determined the observed commercial vehicle characteristics, commercial vehicle exiting/entering behavior, courier's path to deliver goods, accessories used, and accessory movement, delivery characteristics, and human behavior in response to the surrounding built environment.

Section 3.2 explains the research method for the field observations and the data collection form.

Section 3.3 describes each of the categories of the data collection form in detail and explains why each category was important for the scope of this project.

3.2 Field Observation Research Method

The research team used its experience and expertise in urban deliveries to decide that a minimum of 25 deliveries in Seattle should be observed. The research team designed a data collection form that captured 15 critical aspects of delivery characteristics. Appendix 1 shows the data collection form used during observations.

3.3 Data Collection Form Categories

3.3.1 Delivery Location, Date, and Time

The "Delivery Location, Date, and Time" input variable served as an organizing tool to record the location coordinates, date, and time at which observations took place. If the delivery occurred at a CVLZ, details regarding the CVLZ sign were included.

3.3.2 Commercial Vehicle Characteristics

"Truck Characteristics" captured how the couriers interacted with the truck itself, and how they responded to the environment around them during the sorting, loading, and unloading processes.

3.3.3 Delivery Company

If this information was available, the name of the delivery company was recorded to support an examination of any relationship between the delivery company, the types of trucks deployed, the delivery characteristics, and any other qualitative conclusions.

3.3.4 Vehicle Classification

The observed truck was categorized on the basis of the number of axles and the number of tire units on each side of an axle. The classification category used for this effort followed the 13 classes within the Federal Highway Administration's vehicle classification (Appendix 2).

3.3.5 Driver and Passenger Entry/Exit Door Type

The driver and passenger truck door type was recorded because it determined how the courier interacted with the truck and the space around the truck. The driver and passenger door types included swing-out door, sliding door, or no door.

3.3.6 Cargo Compartment Door Location

The cargo compartment door location was noted because it affected how the courier interacted with the truck and the space around the truck. The cargo compartment door location options included back end, passenger side, or driver side.

3.3.7 Cargo Door Type

The cargo vehicle door type determined how the courier interacted with the truck and the space around the truck. The cargo door types included manual lift, roll up, open one door out, open two doors out, or other.

3.3.8 Exiting/Entering Commercial Vehicle Behavior

"Exiting/Entering Truck Behavior" was used to record the movements the courier initially made either outside or inside the truck.

3.3.9 Vehicle Exit/Entry Points

A courier may exit the truck from the driver side, passenger side, or back end (within the truck and through the cargo compartment). This variable was used to associate truck exiting/entering behavior with the truck characteristics, the surrounding environment, and delivery characteristics present at the time of the delivery.

3.3.10 Accessories Used and Accessory Path

The categories of “Accessories Used” and “Accessory Path” exemplified the dynamism involved in making a delivery. The accessories complement the types of goods delivered, and they occupy space outside of the vehicle during the sorting, loading, and unloading processes. During the field observation, subsections of this category were captured.

3.3.11 Accessories Used

The accessories used during delivery affected how the courier interacted with the goods during the loading and unloading process and affected how the courier and accessory interacted with the surrounding environment during the delivery. The type of accessories used in a delivery included ramps, cones, hand trucks, platform trucks, or other observed accessories. Appendix 3 contains images of typical accessories.

3.3.12 Accessory Path – Description at Rest and In Use

The locations of the accessories before their use were recorded. Accessories could be stored on the outside or inside of the truck, and when they were disengaged from the truck for the delivery, they could be temporarily placed outside of the truck. Couriers interacted with the accessories in many ways and used them as tools to facilitate the delivery service. The storage location, the temporary disuse of the accessory after being disengaged, and the active movement of an accessory during the delivery process were recorded because accessories occupy space outside of the vehicle. This was an important aspect of understanding the needs of couriers around their trucks.

3.3.13 Courier Path to Access Cargo – Movements Described Around Commercial Vehicle

The courier path to access the cargo was captured because it described the activities that occur around a delivery truck, and the path around the delivery truck was recorded. Movement could be on either the outside of the driver side, back end, passenger side, or front end of the truck.

3.3.14 Delivery Characteristics and Goods Described

The type of freight delivered served as a proxy for how movements around the vehicle occurred in response to the type of goods being delivered. For example, two couriers might be required to deliver a large sofa to a building. This delivery type would have unique characteristics that would influence the accessories used in the delivery, space required around

the truck, and number of couriers involved in the delivery. During the field observation, each of the subsections of this category were captured.

3.3.15 Number of Couriers

The number of couriers involved in the delivery was recorded because the spatial needs and activity outside of the truck differed depending on the number of couriers actively involved in making the delivery. Three terms were used to describe the courier:

- courier driver – someone who both drives the commercial vehicle and delivers the goods;
- driver – someone who only drives the commercial vehicle;
- courier – someone who only delivers the goods.

3.3.16 Goods Described

The type of goods delivered was recorded and described because the type of goods influenced the accessories used in the delivery and directly affected the way the courier negotiated his/her built environment. Goods included parcels, fresh produce, beverages, large bulky items such as furniture, and other items that were described.

3.3.17 Courier Behavior in Response to the Built Environment (Street, Road, and Land-Use Characteristics)

Courier behavior in response to the built environment was an important category to capture because it recorded unique activity, behavior, or responses that occurred during the delivery. Often, courier behavior was directly affected by what was present in the built environment at the time. For example, if the loading/unloading activity was occurring adjacent to a transit lane, the courier might choose more inconvenient or inefficient behavior to avoid conflict with the transit lane.

3.3.18 Description of Unique Movements Observed

Any obvious courier behavior that responded to specific aspects of the delivery or built environment was described. This was important to capture because it served as a proxy for the human aspect of decision making and delivery operations at a curb space or on the road. The built environment around the truck was described and included information about adjacent bike lanes, transit lanes, buffer lanes, and curb use.

CHAPTER 4. FIELD OBSERVATIONS RESULTS

4.1 Major Takeaways from the Field Observations

This chapter reviews the findings from the 25 field observations. These observations occurred in urban areas in Seattle.

4.2 Observed Commercial Vehicle Classifications

Of the 25 vehicles observed, the majority (18 vehicles) were Class 5 vehicles. According to the Federal Highway Administration classification (Appendix 2), they were identified as two-axle, six-tire, single-unit trucks, which were defined as “all vehicles on a single frame including trucks, camping and recreational vehicles, motor homes, etc., with two axles and dual rear wheels” (FHWA 2016). The seven other trucks observed were smaller, four-tire, single-unit class 3 trucks.

4.3 Number of Delivery Company Staff

Twenty of the 25 deliveries were completed by a single person who was both the driver and courier. The other five deliveries involved two people. This percentage may have been affected by the fact that observations were completed during the holiday season in the United States. Companies may add staff to a route to off-set the larger number of deliveries occurring during the holiday season.

These results indicated that adequate door opening space be certainly provided on the driver’s side of the vehicle for safe and comfortable ingress and egress, and less attention may be given to the passenger’s side.

4.4 Driver and Passenger Door Type

A majority of the observed vehicles (18) had open out or swing-out doors, which indicated that at a minimum, a commercial vehicle operating envelope should include additional space for the opening door radius. This could affect the design considerations and suggestions resulting from this research project. The other seven vehicles had sliding doors that did not occupy space outside of the vehicle footprint.

4.5 Cargo Compartment Location

Sixteen of the 25 observed vehicles had cargo compartments located at the back end of the vehicle. This indicated that additional space is required behind a vehicle for the driver/courier to organize goods, load accessories, and maneuver with accessories.

Close to half of the observed vehicles had cargo compartments on the passenger side. Only two of the observed vehicles exclusively had cargo compartments located on the driver's side of the vehicle. The vehicles that had this configuration were beverage vehicles with side cargo compartments.

4.6 Lift Gate Presence

A majority of the vehicles did not have a lift gate, but the three that did required significantly more space to operate. Curb cuts or narrow parking lanes were observed as a hindrance for the convenient use of the lift gate. Narrow parking lanes meant that the lift gate overhung into the adjacent transit lane. Curb cuts may obstruct lift gate operations and may not allow the lift gate to sit flush against the pavement.

4.7 Accessory Type

Hand trucks were used in 13 of the 25 deliveries. For the observations, the hand truck category included both hand trucks and two-way convertible hand trucks. These observations indicated that the turning radius of a hand truck around the vehicle is important to consider. Four of the delivery couriers did not use any accessory and carried a package by hand. Other accessories observed being used were pallet jacks (two deliveries), ramps (one delivery), cones (one delivery), hampers (one delivery), and bins (four deliveries).

4.8 Side of Vehicle Used During Loading/Unloading

The movements around the vehicle were counted only once (regardless of how frequently a side was used during the observed delivery) or not at all. Eleven of the drivers/couriers operated at the back end of the observed vehicle. This included walking past the back end or participating in loading/unloading activities at the back end of the vehicle.

For most of the observed deliveries, one person who was both the driver and courier completed the delivery. Therefore, it is not surprising that a majority of the observed vehicles had activity on the driver's side. These activities included ingress/egress, walking past this side

of the vehicle, or participating in any loading/unloading activities on this side of the vehicle. However only seven of the loading activities occurred on the driver's side of the vehicles.

There was a general split between activities occurring on the passenger side of the observed vehicles. Some of these observed vehicles had cargo compartments on the passenger side. Six of the observations had loading activity that occurred on the passenger.

Just one delivery observation occurred in front of the truck.

CHAPTER 5. SIMULATED DELIVERIES

5.1 Introduction

As covered in the previous chapter, 25 urban deliveries in Seattle were observed and recorded. This informed the research team of the typical behaviors, characteristics, and vehicle types involved in urban deliveries.

To build on the qualitative information captured in Chapter 4, the next step for the research team was to capture quantitative measurements of the movements around commercial vehicles during a delivery.

Initially, the research team brainstormed ways to measure the movements of couriers around their parked commercial vehicle during field observations. However, it was not possible to measure the movements of the 25 observed deliveries because of safety concerns and time constraints. Measuring the operating envelope of the observed deliveries in real time would require the research team to step into active transit lanes in order to capture movements, which the research team considered high risk. Instead, the research team developed an alternative method to capture the movements around commercial vehicles during deliveries by simulating deliveries in a controlled environment.

The research team collaborated with University of Washington's Urban Freight Lab, United Postal Service (UPS), Charlie's Produce, and the University of Washington's Moving Services team to simulate urban deliveries so that the research team could observe and record courier driver and accessory movements around parked commercial vehicles. Because of these partnerships, the research team successfully measured, recorded, and analyzed movements around each commercial vehicle. In addition, the research team captured meaningful qualitative data related to urban deliveries by interviewing the courier drivers at each of the three organizations.

5.2 Data Collection Method

The research team requested participating organizations to volunteer one hour at their respective facilities and to make their typical urban delivery vehicles, accessories, and goods available for the simulated delivery. The goal of the data collection method was to measure and record movements around a vehicle during a delivery, so that the research team could understand the minimum operating envelope needed around a commercial vehicle.

During the simulated deliveries, three to four people from the research team participated. One researcher was responsible for directing and interviewing the courier driver, and two to three researchers were responsible for measuring and documenting the closed, open, and active vehicle footprints.

The research team used the following tools to capture measurements during the simulated deliveries:

- Safety vests
- 25-ft. measuring tapes
- chalk for pavement marking
- camera
- pens
- simulation data collection form (see Appendix 4 for this form).

The steps involved in the data collection process for simulated deliveries were as follows:

Step 1 – Closed Vehicle Footprint

The closed vehicle footprint was the commercial vehicle's measurements at rest without any possible extensions engaged. The truck's overall dimensions, including its length, width, and height, were recorded. The team measured at the widest possible place, including wheel nuts, protruding blinkers or mirrors, and other details of the vehicle.

Step 2 – Open Vehicle Footprint

The open vehicle footprint was the vehicle's measurements when all parts of the vehicle were extended. These included all doors and hatches and all accessories, such as ramps and lift gates.

Step 3 – Active Vehicle Footprint (Courier and Accessory)

The active vehicle footprint was the area around the vehicle used by the courier and any accessories to complete the simulated delivery. A member of the research team asked the courier driver to complete a typical delivery in an urban environment such as downtown Seattle, and to express the amount of space they *needed* and the amount of space they *desired*. As the courier responded by physically showing the *space needed* and *space desired*, the location of the courier and accessory's movements were marked with chalk. (In a number of cases, needed and desired space were the same.) The chalk markings indicated the courier's movement, as well as the

location, dimensions, and movements of the delivery equipment, including turning radii and dwelling spots. The chalk markings were then denoted with letters, measured, and documented by the research team. For measurements located directly to the side or directly behind the vehicle, the measurements were documented as distance from the vehicle, and for measurements located at a diagonal, the nearest corner of the truck was the measured point.

Step 4 – Interview

The courier driver was interviewed and asked a series of eight questions to better understand courier behavior, the experience of making urban deliveries, and the decision-making deployed during deliveries. The interview questions can be found in Appendix 5. The interview questions were edited after the first interview to capture more details. Therefore, the responses from UPS and Charlie’s Produce were more detailed than those from UW Moving Services.

5.3 Schematic Key

A schematic of the vehicle and movements of the courier driver and accessories was created for each step. Measurements were recorded in inches, from the vehicle/vehicle’s extension to the accessory or courier driver. Figure 5.1 was the key used to record the different movements.

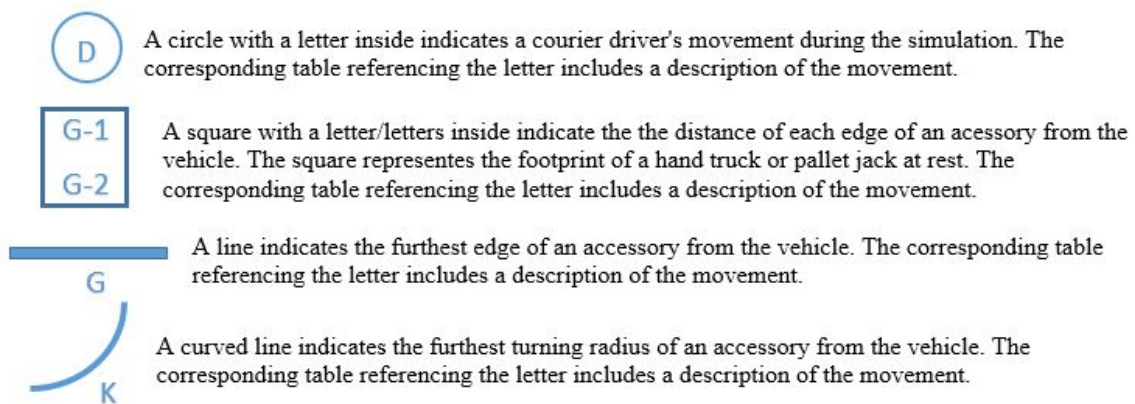

Figure 5.1 Simulation measurement key

5.4 University of Washington (UW) Moving Services Simulation

The data from the UW Moving Services group were collected on February 13, 2018. For this simulation, the research team went to the UW Plant Services Building, located at the University of Washington-Seattle campus for the simulation. Two members of the research team

were present, and two representatives of the UW Moving Services were available for the simulation and to answer questions.

Two commercial vehicles were made available to the research team, a 16-foot vehicle and a 24-foot vehicle. The measurements of each vehicle’s closed, open, and active footprint are outlined below.

Step 1- UW – 16-Footer Closed Vehicle Footprint



Figure 5.1 UW 16-footer closed footprint (left) 16-footer open footprint (right)

Figure 5.2 UW 16-footer schematic: closed vehicle measurement

Table 5.1 UW 16-footer: closed vehicle measurements

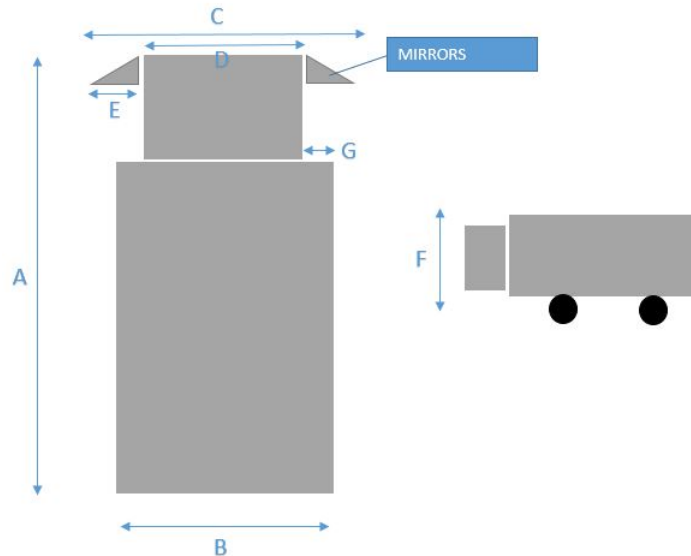

ID	Measurement (in)	Description
A	266	Closed Footprint, total length
B	118	Cargo Compartment, width
C	102	Cab with mirrors, width
D	96	Cab no mirrors, width
F	129.5	Closed Footprint, Total height
G	11	Cab to outside edge, width

Step 2 - UW – 16-Footer Open Vehicle Footprint

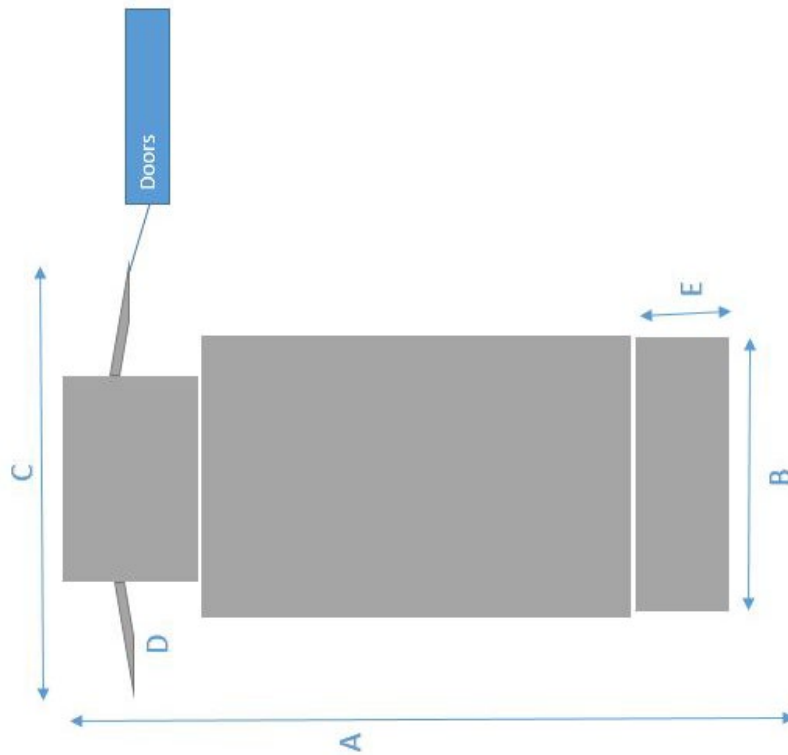

Figure 5.3 UW 16-footer schematic: open vehicle measurements

Table 5.2 UW 16-footer: open vehicle measurements

ID	Measurement (in)	Description
A	336	Open Footprint, total length
B	96	Lift Gate, length
C	166	Open doors, total width
D	43	Door, width
E	76	Lift Gate, width

Step 3 - UW – 16-Footer Active Vehicle Footprint

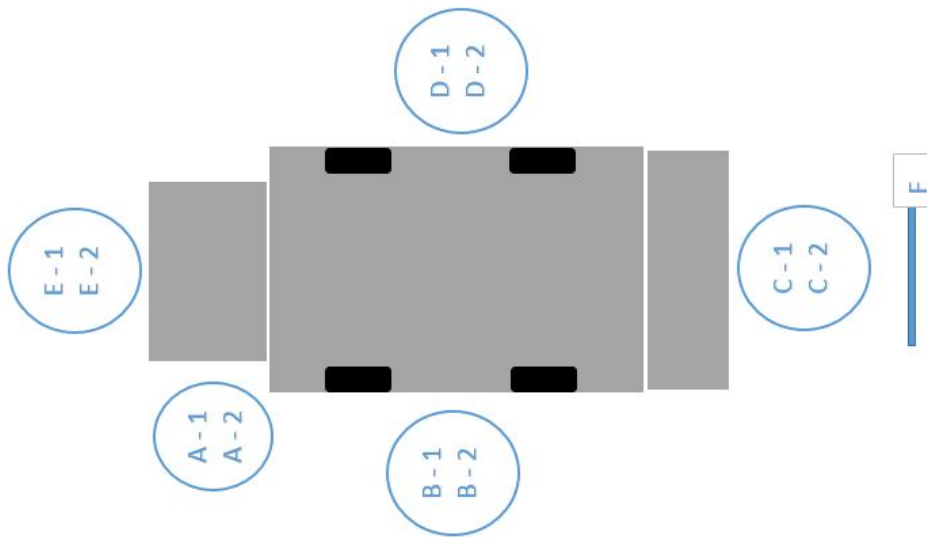

Figure 5.4 UW 16-footer schematic: active vehicle measurements

Table 5.3 UW 16-footer: active vehicle measurements

ID	Measurement (in)	Description
A-1	33	Need for courier driver
A-2	54	Want for courier driver
B-1	42	Need for courier driver
B-2	56	Want for courier driver
C-1	60	Need for courier driver
C-2	92	Want for courier driver
D-1	31	Need for courier driver
D-2	54	Want for courier driver
E-1	23	Need for courier driver
E-2	50	Want for courier driver
F	77	Need + Want for Accessory

Step 1 - UW – 24-Footer Closed Vehicle Footprint

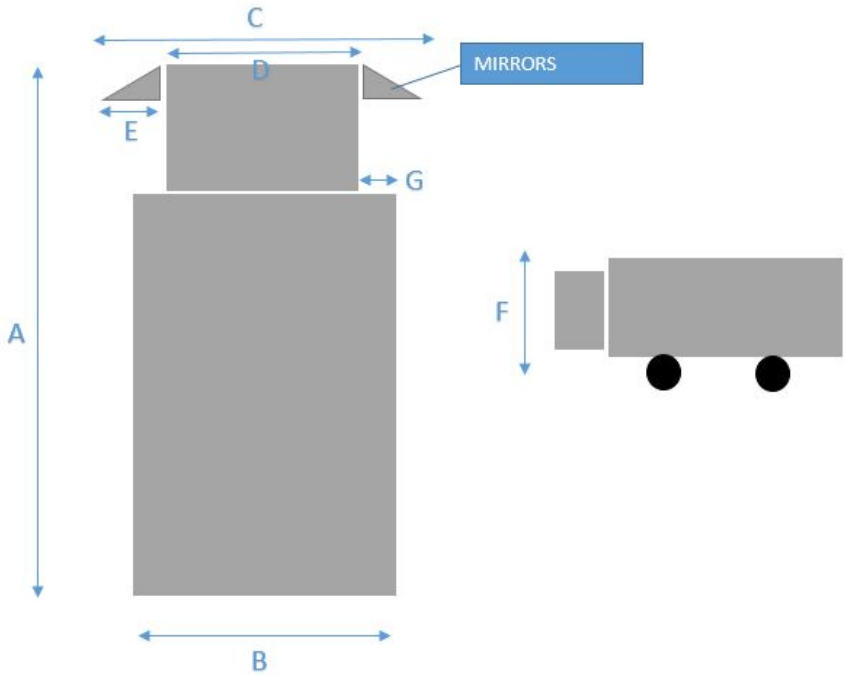

Figure 5.5 UW 24-footer schematic: closed vehicle measurements

Table 5.4 UW 24-footer: closed vehicle measurements

ID	Measurement (in)	Description
A	396	Closed Footprint, total length
B	86	Cargo Compartment, width
C	106	Cab with mirrors, width
D	84	Cab no mirrors, width
E	11	Mirror from cab, width
F	145.5	Closed Footprint, Total height
G	1	Cab to outside edge, width

Step 2 - UW – 24-Footer Open Vehicle Footprint

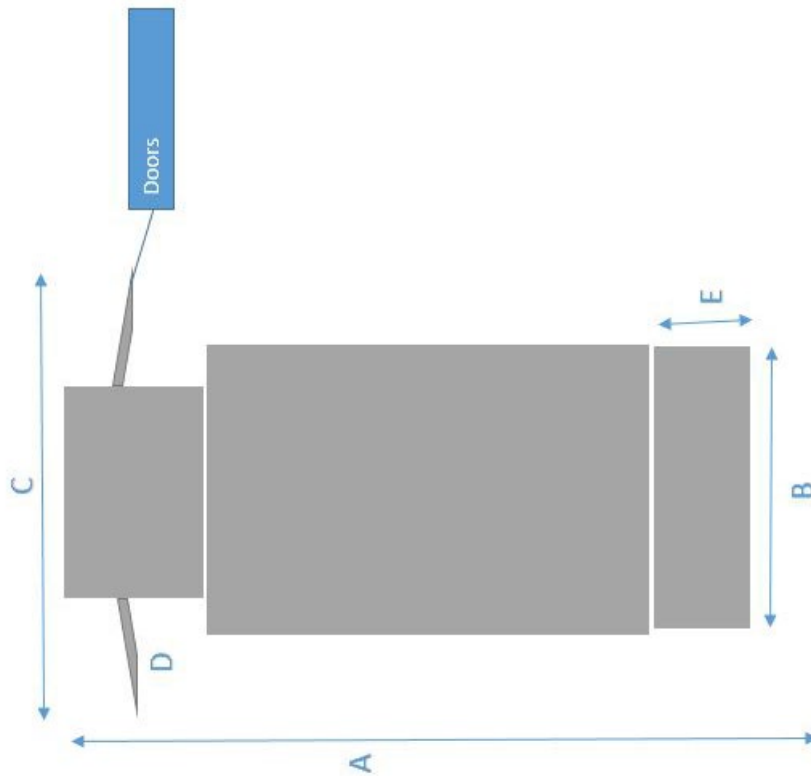

Figure 5.6 UW 24-footer: open vehicle measurements

Table 5.5 UW 24-footer: open vehicle measurements

ID	Measurement (in)	Description
A	480	Open Footprint, total length
B	100	Lift Gate, length
C	166	Open doors, total width
D	41	Door, width
E	84	Lift Gate, width

Step 3 - UW – 24-Footer Active Vehicle Footprint



Figure 5.7 UW 24-footer active footprint simulation

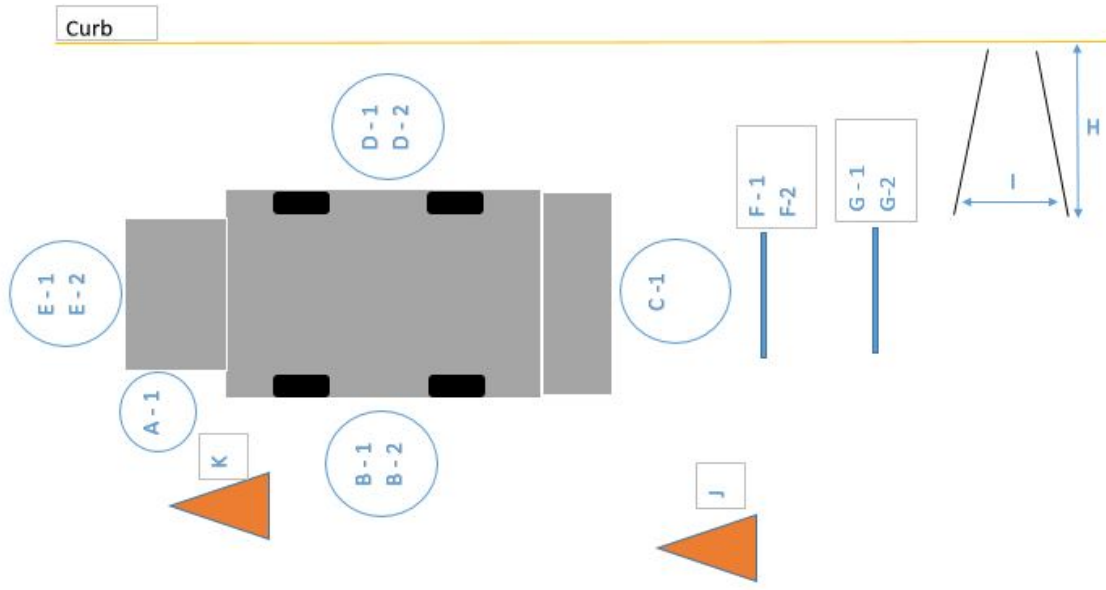

Figure 5.8 UW 24-footer: active vehicle measurements

Table 5.6 UW 24-footer: active vehicle measurements

ID	Measurement (in)	Description
A-1	27	Need + Want for courier driver
B-1	26	Need for courier driver
B-2	38	Want for courier driver
C-1	62	Need + Want for courier driver
D-1	26	Need for courier driver
D-2	38	Want for courier driver
E-1	14	Need for courier driver
E-2	70	Want for courier driver
F-1	64	Need for Cart (Accessory)
F-2	117	Want for Cart (Accessory)
G-1	39	Need for Hand Truck (Accessory)
G-2	117	Want for Hand Truck (Accessory)
H	48	Length of Transportable ramp (Accessory)
I	36	Width of Transportable Ramp (Accessory)
J	121	Curb to Cone Distance
K	124	Curb to Cone Distance

Step 4 – UW Interview

After deliveries had been simulated, measured, and recorded, the research team interviewed the courier driver and asked eight questions. The responses included in this report are paraphrased.

1. What causes the most problems while loading/unloading?

Access to the building the parcel is going to and the sidewalk causes the most problems. Watching out for pedestrians is also a challenge.

2. Is there enough space to comfortably get in and out of your vehicle?

Yes, there is enough space to get in and out of my vehicle.

3. Is there enough space to maneuver and use this accessory?

Yes, there is enough space to maneuver and use the accessories.

4. Mark where you **usually** load/unload goods.

I usually load/unload behind the vehicle.



5. Mark where you **prefer** to load/unload goods.

On the adjacent sidewalk.

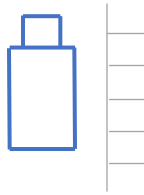

6. What are the most common accessories used with this vehicle type?

Hand trucks and four-wheel dollies.

7. What infrastructure helps you load/unload? (Infrastructure - the basic, underlying framework or features of a system or organization (1) [e.g., curb cuts, clear pavement markings, curb ramps, visible curb paint, etc.])

Curb cuts help me load/unload.

8. What would you change about the design of commercial vehicle load zones?

I would want them to be longer.

5.5 United Postal Service (UPS) Simulation

The data for United Postal Service (UPS) were collected on February 26, 2018, at the UPS warehouse and distribution center in Tukwila, Washington. UPS made available two commercial vehicles to the research team—a package car and a 24-footer—along with one supervisor, who was also the courier driver in this simulation.

The measurements of each vehicle's closed, open, and active footprint are outlined below.

Step 1 - UPS - Package Car Closed Vehicle Footprint



Figure 5.1 UPS closed footprint vehicle simulation

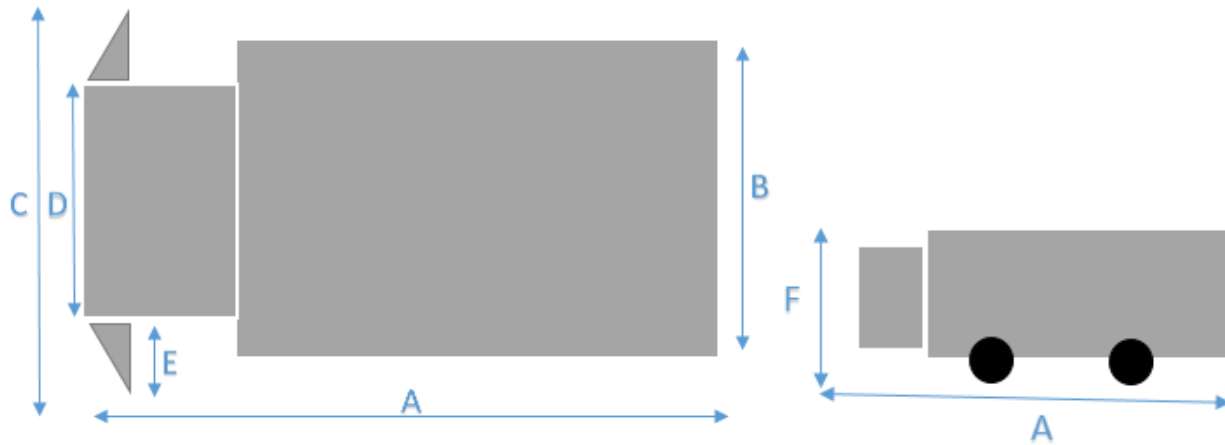

Figure 5.2 UPS package car schematic: closed vehicle Measurements

Table 5.7 UPS package car: closed vehicle measurements

ID	Measurement (in)	Description
A	317	Closed Footprint, total length
B	95	Cargo Compartment, width
C	118.5	Cab with mirrors, width
D	98.5	Cab no mirrors, width
E	10	Mirror from cab, width
F	118.5	Closed Footprint, Total height

Step 2 - UPS - Package Car Open Vehicle Footprint

The UPS package car did not have any open footprint measurements, as this vehicle type does not have any possible extensions, so the open footprint measurements were the same as the closed footprint measurements.

Step 3 - UPS - Package Car Active Vehicle Footprint

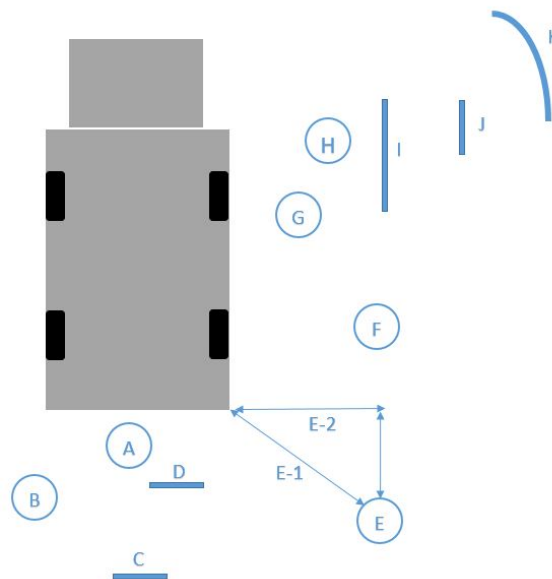

Figure 5.3 UPS package car schematic: delivery movements measurements

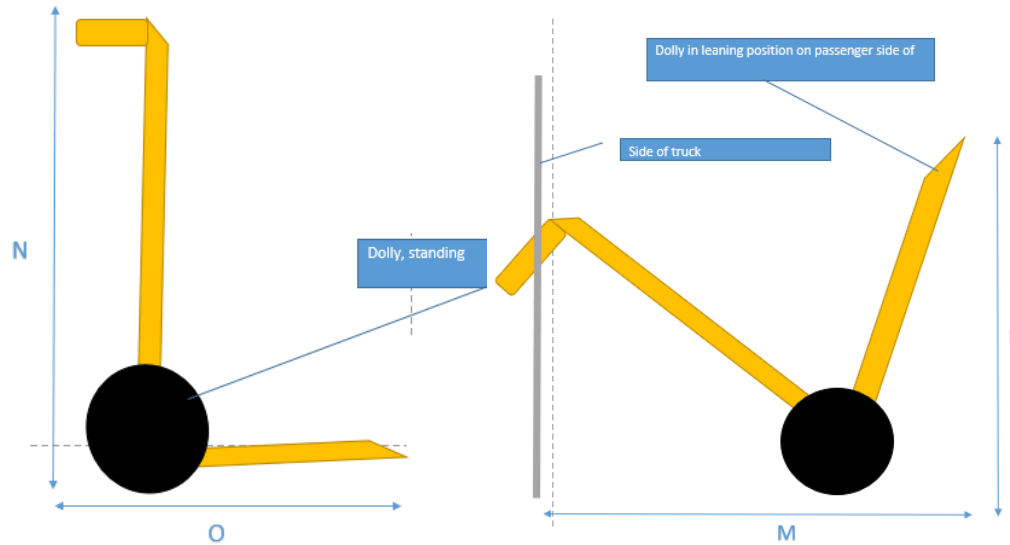

Figure 5.4 UPS package car accessory schematic: accessories measurements

Table 5.8 UPS package car: delivery movements and accessories measurements

ID	Measurement (in)	Notes
A	36	Need + Want for courier driver to load/unload
B	64	Need + Want for courier driver
C	86	Resting Hand Truck #2 (Accessory)
D	48.5	Resting Hand Truck #1 (Accessory)
E-1	39	Need + Want for courier driver
E-2	27	Need + Want for courier driver
F	32.5	Need + Want for courier driver
G	23	Need + Want for courier driver while operating hand truck
H	34	Need + Want for courier driver while operating hand truck
I	64	Hand Truck 1 (Accessory)
J	77	Hand Truck 2 (Accessory)
K	107	Two dollies, swing
L	39.5	Height of resting hand truck, with angle
M	51	Width of resting hand truck, from cab to end of angle
N	53	Total height of hand truck, standing
O	44	Total length of hand truck, standing

Step 1 - UPS – 24-Footer Closed Vehicle Footprint

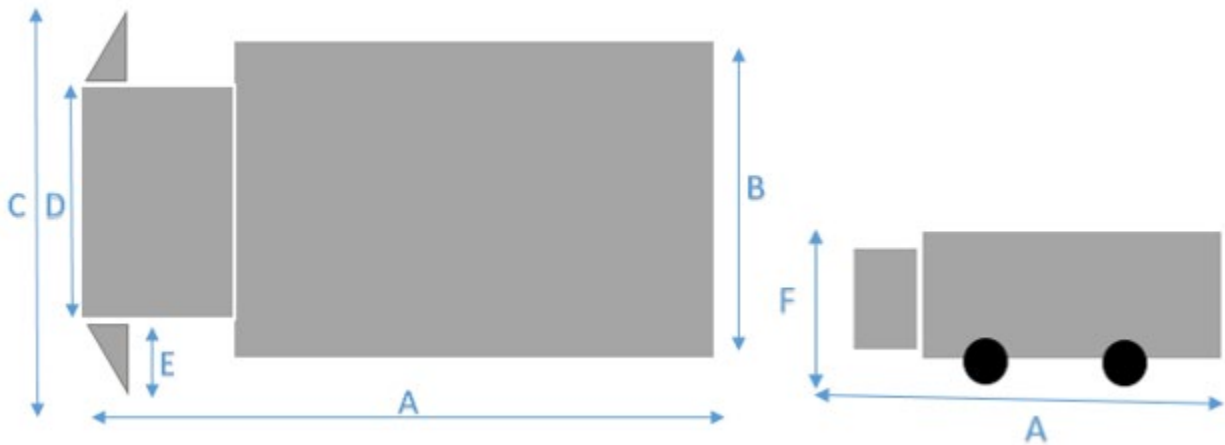

Figure 5.5 UPS 24-ft box truck schematic: closed vehicle measurements

Table 5.9 UPS 24-ft box truck: closed vehicle measurements

ID	Measurement (in)	Description
A	403	Closed Footprint, total length
B	95.5	Cargo Compartment, width
C	106	Cab with mirrors, width
D	87	Cab no mirrors, width
E	9.5	Mirror from cab, width
F	145.5	Closed Footprint, total height

Step 2- UPS – 24-Footer Open Vehicle Footprint

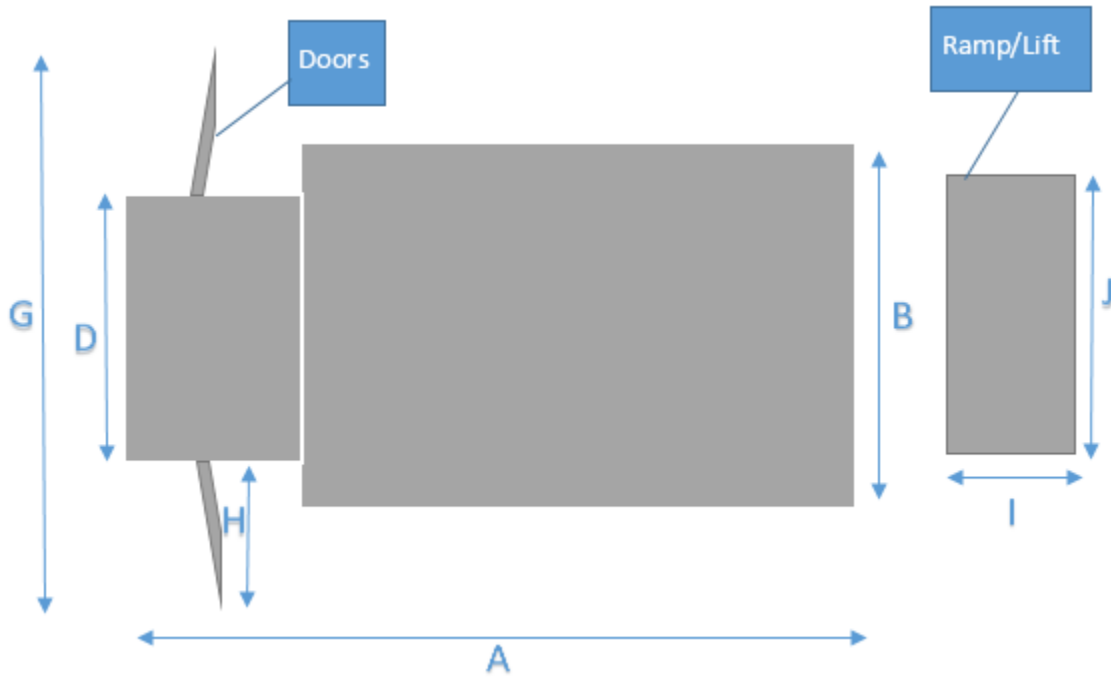

Figure 5.6 UPS 24-ft box truck schematic: open vehicle measurements

Table 5.10 UPS 24-foot box truck: open vehicle measurements

ID	Measurement (in)	Description
A	317	Open Footprint, total length
B	95	Cargo Compartment, width
D	98.5	Cab no mirrors, width
G	149	Open doors, total width
H	25	Door, width
I	96	Lift Gate, width
J	144	Lift Gate, length

Step 3 - UPS 24-Footer Active Vehicle Footprint

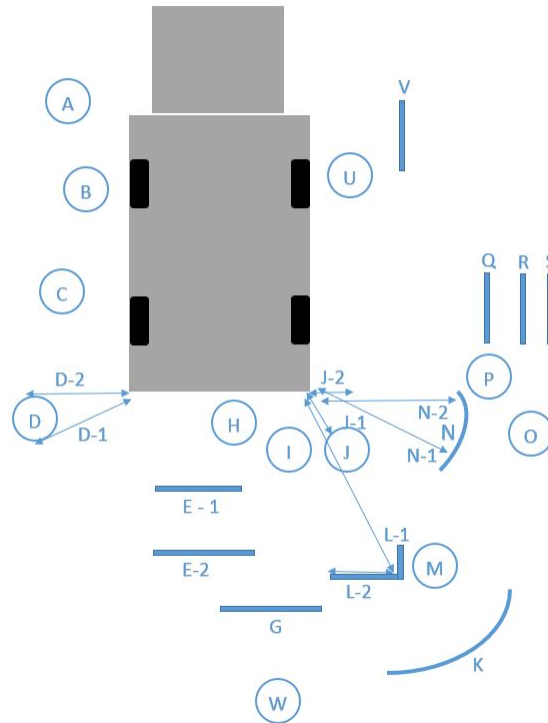

Figure 5.7 UPS 24-ft box truck schematic: delivery movements measurements

Table 5.11 UPS 24-ft box truck: delivery movements measurements

ID	Measurement (in)	Description
A	32	Need + Want for courier driver
B	26	Need + Want for courier driver
C	32	Need + Want for courier driver
D-1	38	Need + Want for courier driver
D-2	41	Need + Want for courier driver
E-1	68	Hand truck wheels
E-2	92	Hand truck tongue
G	162.5	Pallet jack movement (Accessory)
H	33	Need + Want for courier driver
I	31	Need + Want for courier driver
J-1	31	Need + Want for courier driver
J-2	9	Need + Want for courier driver
K	156	Pallet jack turning radius (Accessory)
L-1	140	Pallet jack at rest (Accessory)
L-2	40	Pallet jack at rest (Accessory)
M	67.5	Courier driver movement with pallet jack

ID	Measurement (in)	Description
N-1	89	Accessory Movement
N-2	43	Accessory Movement
O	75	Need + Want for courier driver
P	30.5	Need + Want for courier driver
Q	38.5	Edge of pallet jack
R	58	Parcel hangover off of hand truck
S	67	Pallet handover distance
U	21	Need + Want for courier driver
V	35.5	Edge of pallet jack
W	178.5	Need + Want for courier driver

Step 4 – UPS Interview

After deliveries had been simulated, measured, and recorded, the research team interviewed the courier driver and asked eight questions. The responses are given from the perspective of using a UPS package car, unless noted otherwise. The responses included in this report are paraphrased from a recording of the interview.

1. What causes the most problems while loading/unloading? Why?

The size and number of the packages will determine where the vehicle is parked and how they are loaded/unloaded. This determines how much space is needed on the side of the curb to operate for that specific delivery, without facing any obstructions. Ideally, in an urban environment, a conducive parking spot allows the vehicle to be parked flush against a clear curb that allows deliveries from the passenger side of the vehicle or the back end of the vehicle to be completed.

2. Is there enough space to comfortably get in and out of your vehicle?

To exit/enter the vehicle, there usually isn't enough space because the number of vehicles that are using load/unload space forces us to double park or park in an unideal location. This is why, I am always thinking ahead to the next delivery. I ask myself, "What's my next stop, where it is, how many packages do I have, and where am I going to park?" If my first parking choice is not available, I don't spend a lot of time circling to look for parking, I rather double park or do something else so that I do not waste my time.

3. Is there enough space to maneuver and use this accessory (hand truck)?

There usually is enough space when I am on the curb to use it. Sometimes, the space behind my vehicle is inadequate when another vehicle pulls up behind my parked vehicle. If this happens, then I park the hand truck on the curb, and I work with the hand truck between the two parked cars.

4. Mark where you **usually** load/unload goods. Why?

I prefer to load/unload outside of the passenger door because there are no obstructions on the curb and it keeps me safe, and I am usually moving packages that are in the vehicle forward so that I am working with packages that are placed closest to the passenger door. That's what I prefer. The hand truck would ideally be resting at an angle on the steps located inside the vehicle on the passenger side. If that is not possible because of the size of the package, then the hand truck would be placed on the sidewalk.

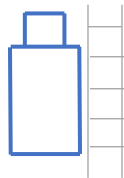

5. Mark where you **prefer** to load/unload goods. Why?

I prefer the passenger side of the vehicle, but for loading, then I prefer to enter the cargo compartment from the back end of the vehicle and load within the cargo compartment. If I am on the curb, then I load from the passenger side of the vehicle and place packages in the cargo compartment. The main preference is to enter the cargo compartment from the back end of the vehicle and the load within the cargo compartment.



6. What are the most common accessories used with this vehicle type? Why?

For the package car, the hand truck/dolly is the most common because it has two wheels, maneuverability, has a tighter radius, the tongue of the hand truck can accommodate more parcels, or I can remove the tongue if necessary. On average, six

paper boxes weighing 40 lbs. each can fit onto a hand truck maximum. If packages hang off of a hand truck, then the overhang is generally 6 inches to 1 foot on each side of the hand truck.

For the 24-footer, a pallet jack is most common because we do many dock deliveries. Pallet jacks are only used if pallets need to be delivered, and sometimes, we use the pallet jack that belongs to the business we are delivering to. We will also use hand trucks for on the ground.

7. What infrastructure helps you load/unload? Why? (Infrastructure—the basic, underlying framework or features of a system or organization [e.g., curb cuts, clear pavement markings, curb ramps, visible curb paint, etc.]?)

Clean access to designated and defined curb space where there aren't any obstructions like bike racks. That way, I know that no other vehicle will come and take that space, and that the curb space is designated to us. It is also really nice to have a flat street.

We often make deliveries from the passenger side, and our dolly is placed on the curb, curb cuts (presence/lack of) are not critical. It would be different if we mainly used a pallet jack. Our vehicles are built with the constraints we often face making deliveries in mind.

8. What would you change about the design of commercial vehicle load zones? Why?

The people who use it because there are people who use commercial vehicle load zones that should not be. It is important to make sure that the right people, with the right vehicle types are using them. For example, people with personal vehicles making deliveries out of them could park anywhere, so that vehicles who actually need that space can have adequate space.

When I am unloading from the passenger side door, then the design is fine, but if I have to load/unload from the back end of the vehicle, then there is a bit of unpredictability because another vehicle can pull up behind the parked commercial vehicle. This can limit the space I know have to operate behind my vehicle. This would especially be challenging if heavier equipment is used, like a pallet jack. It would be also nice to have more commercial load zones.

9. Side notes from Discussion – If there is a CVLZ that is longer than my vehicle, then I park it in such a way that I have more space in front of my vehicle. This ultimately allows me to easily exit the parking spot.

The ideal location of the CVLZ on a street block varies. If there are storefronts along the front, then the middle is the best because it reduces walking distance.

If there is a passenger vehicle load zone behind my commercial vehicle load zone space, then I pull up to the front of the CVLZ so that I can have as much space behind my vehicle to load/unload.

Parking is by far the biggest restraint on how hard I have to work and how much time I spend working. The ability to deliver from my vehicle with ease is important. So the number of CVLZs and the placement of those is important to consider.

We never want to back up, because of poor visibility. It's a last resort action.

Deliveries from the 24-foot vehicle perspective is different because of the amount of space needed behind the 24-footer. It needs ample space behind the vehicle so that a pallet can get in and out, and so that I can work behind the vehicle without having to worry that this space is compromised. The 24-footer usually hangs over the CVLZ.

5.6 Charlie's Produce Simulation

The data for Charlie's Produce (CP) was collected on February 27, 2018, at its warehouse and distribution center in Seattle, Washington. CP had made three types of vehicles available for data collection, along with one employee courier driver and one supervisor to participate in the simulation and to answer questions.

The vehicles made available at CP included two types of refrigerated box trucks, one with a manually extendable ramp and a larger one with an electrical lift gate, and a delivery van with both side and back access doors. The measurements of each vehicle's closed, open, and active footprint are described below.

Step 1 - Charlie's Produce - Delivery Van Closed Vehicle Footprint

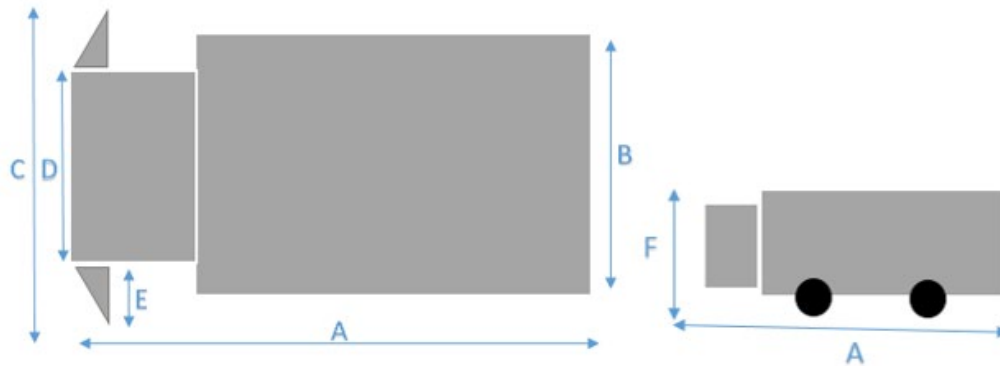

Figure 5.1 Charlie's Produce delivery van: closed vehicle measurements

Table 5.12 Charlie's Produce delivery van: closed vehicle measurements

ID	Measurement (in)	Description
A	236	Closed Footprint, total length
B	75	Cargo Compartment, width
C	96	Cab with mirrors, width
D	75	Cab no mirrors, width
E	10.5	Mirror from cab, width
F	99	Closed Footprint, Total height

Step 2 - Charlie's Produce - Delivery Van Open Vehicle Footprint

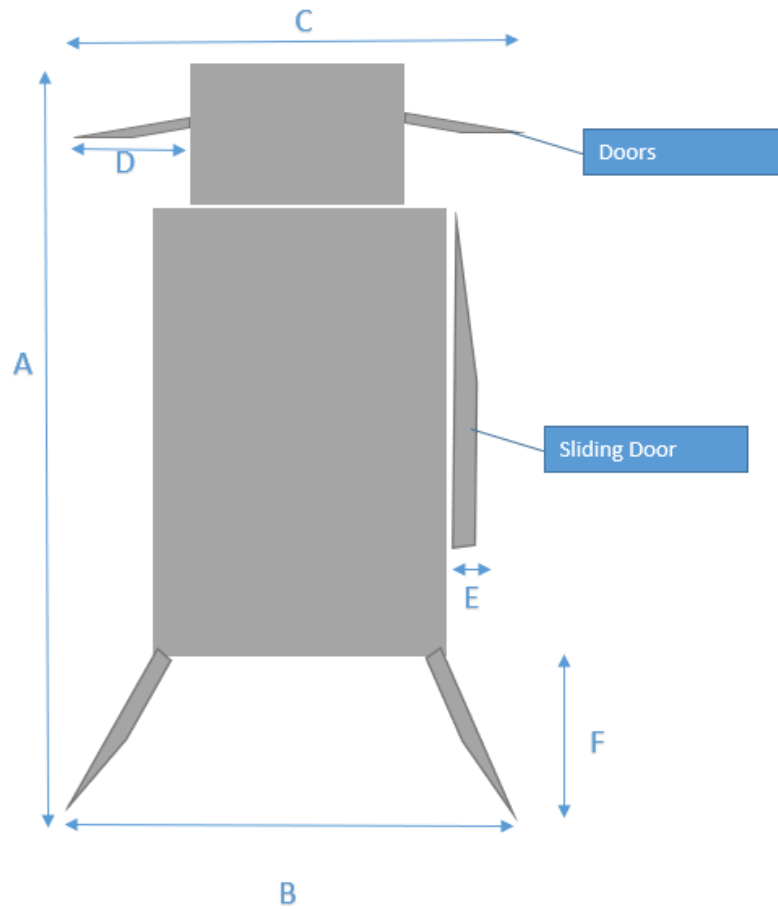

Figure 5.2 Charlie's produce delivery van: open vehicle measurements

Table 5.13 Charlie's Produce delivery van: open vehicle measurements

ID	Measurement (in)	Description
A	267	Open Footprint, total length
B	80	Cargo Compartment, width
C	151	Open doors, total width
D	36	Door, width
E	6	Sliding door, width
F	31	Back doors, length

Step 3 - Charlie's Produce - Delivery Van Active Vehicle Footprint

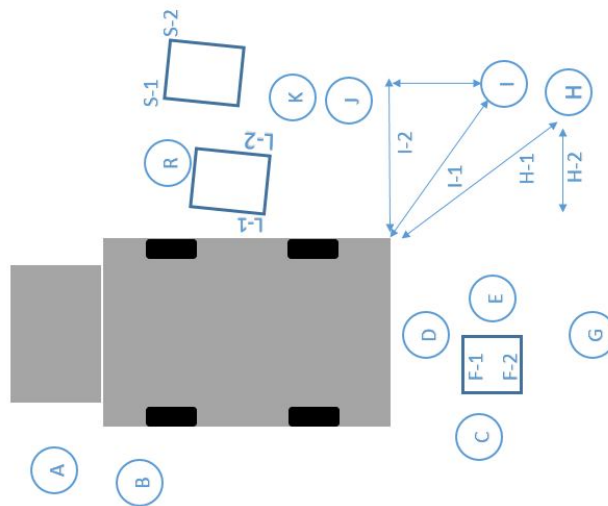

Figure 5.3 Charlie's Produce delivery van: delivery movements measurements

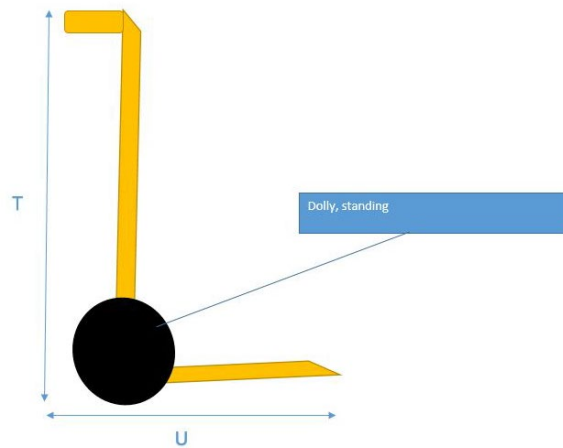

Figure 5.4 Charlie's Produce delivery van: accessories measurements

Table 5.14 Charlie's Produce delivery van: delivery movements and accessories measurements

ID	Measurement (in)	Description
A	13	Need for courier driver
B	25	Courier driver movement
C	41	Need + Want for courier driver
D	14	Need for courier driver
E	29	Need + Want for courier driver
F-1	39	Resting hand truck need + want
F-2	59	Resting hand truck need + want
G	30	Want for courier driver

ID	Measurement (in)	Description
H-1	30	Need + Want for courier driver
H-2	8	Need + Want for courier driver
I-1	28	Need + Want for courier driver
I-2	16	Need + Want for courier driver
J	23	Courier driver movement
K	7.5	Need for courier driver
L-1	5	Resting hand truck need
L-2	22	Resting hand truck need
R	23	Need for courier driver
S-1	30	Resting hand truck want
S-2	51	Resting hand truck want
T	54	Total height of hand truck
U	17	Width of hand truck

Step 1 - Charlie's Produce - Box Truck with Ramp Closed Vehicle Footprint

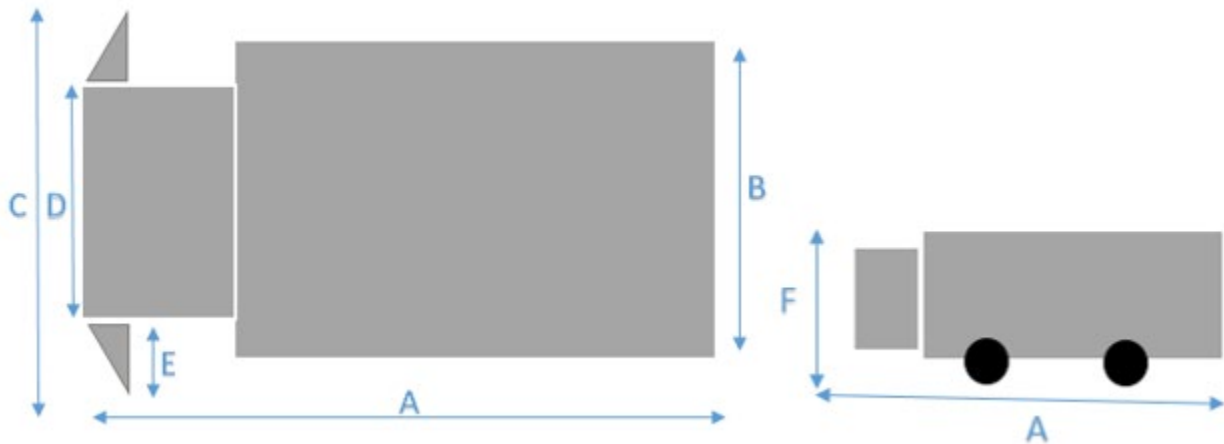

Figure 5.5 Charlie's Produce box truck with ramp: closed vehicle measurements

Table 5.15 Charlie's Produce box truck with ramp: closed vehicle measurements

ID	Measurement (in)	Description
A	302	Closed Footprint, total length
B	96	Cargo Compartment, width
C	120	Cab with mirrors, width
D	78	Cab no mirrors, width
E	12	Mirror from cab, width
F	128.5	Closed Footprint, total height

Step 2 - Charlie's Produce - Box Truck with Ramp Open Vehicle Footprint

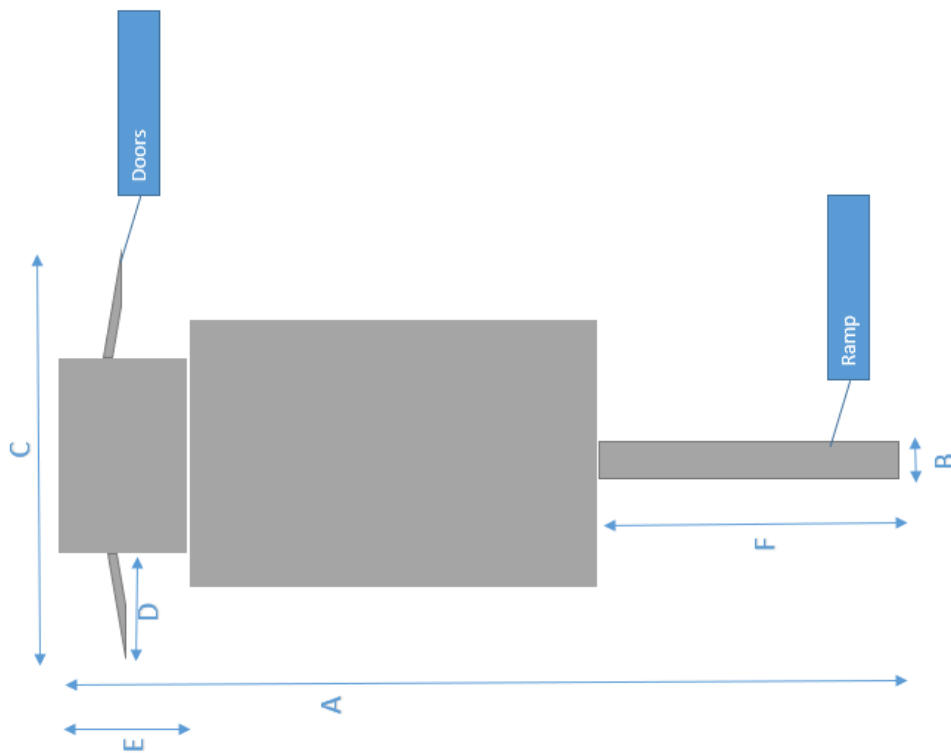

Figure 5.6 Charlie's Produce box truck with ramp: open vehicle measurements

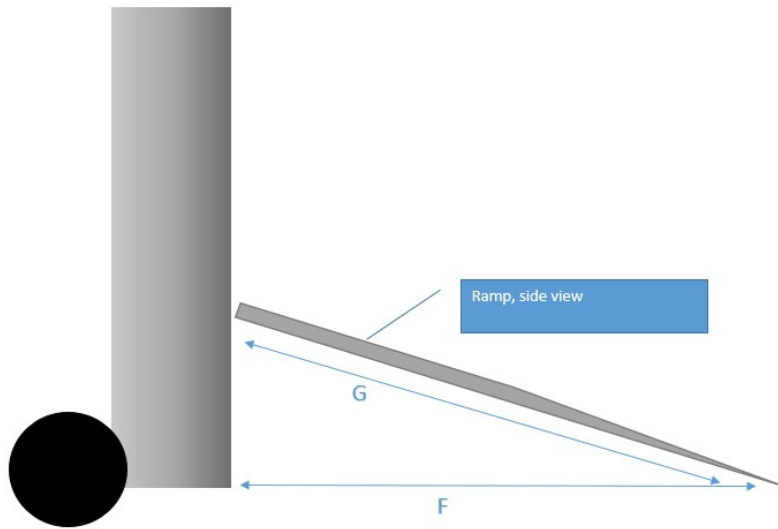

Figure 5.7 Charlie’s Produce box truck with ramp: open vehicle measurements - ramp profile

Table 5.16 Charlie’s Produce box truck with ramp: open vehicle measurements

ID	Measurement (in)	Description
A	460	Open Footprint, total length
B	26	Ramp, width
C	151	Open doors, total width
D	45	Door, width
E	76	Cab, length
F	158	Flat Ramp, length
G	165	Engaged Ramp (angle), length

Step 3 - Charlie’s Produce - Box Truck with Ramp Active Vehicle Footprint

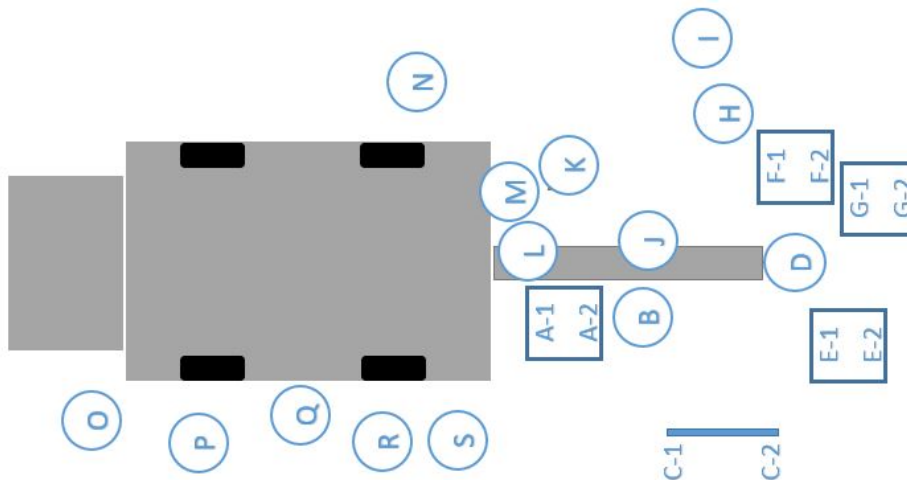

Figure 5.8 Charlie’s Produce box truck with ramp: delivery movements measurements

Table 5.17 Charlie’s Produce box truck with ramp: delivery movements measurements

ID	Measurement (in)	Description
A-1	35	Resting hand truck
A-2	52	Resting hand truck
B	71	Courier driver movement
C-1	76	Width of resting hand truck
C-2	97	Width of resting hand truck
D	7.5	Need for courier driver
E-1	47.5	Turning hand truck
E-2	68.5	Turning hand truck
F-1	22.5	Turning hand truck
F-2	40	Turning hand truck
G-1	51.5	Turning hand truck
G-2	66.5	Turning hand truck
H	145	Courier driver movement
I	80	Courier driver movement
J	41	Courier driver movement
K	32	Courier driver movement
L	21	Courier driver movement
M	20	Courier driver movement
N	15	Courier driver movement
O	18	Need + Want for courier driver
P	19	Courier driver movement
Q	14	Want for courier driver
R	18	Want for courier driver
S	19	Courier driver movement

Step 1 - Charlie’s Produce - Box Truck with Lift Closed Vehicle Footprint



Figure 5.9 Refrigerated box truck with lift gate at Charlie's Produce

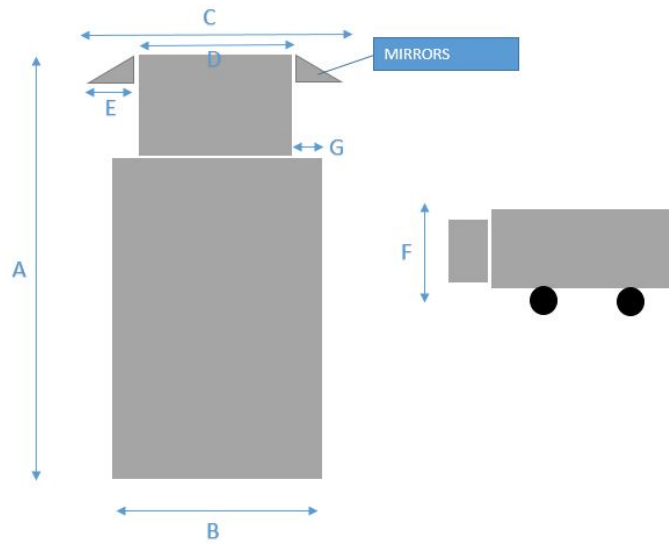

Figure 5.10 Charlie's Produce box truck with lift: closed vehicle measurements

Table 5.18 Charlie's Produce box truck with lift: closed vehicle measurements

ID	Measurement (in)	Description
A	386	Closed Footprint, total length
B	98.5	Cargo Compartment, width
C	126	Cab with mirrors, width
D	94	Cab no mirrors, width
E	16	Mirror from cab, width
F	151	Closed Footprint, Total height
G	2	Cab to outside edge

Step 2 - Charlie's Produce - Box Truck with Lift Open Vehicle Footprint

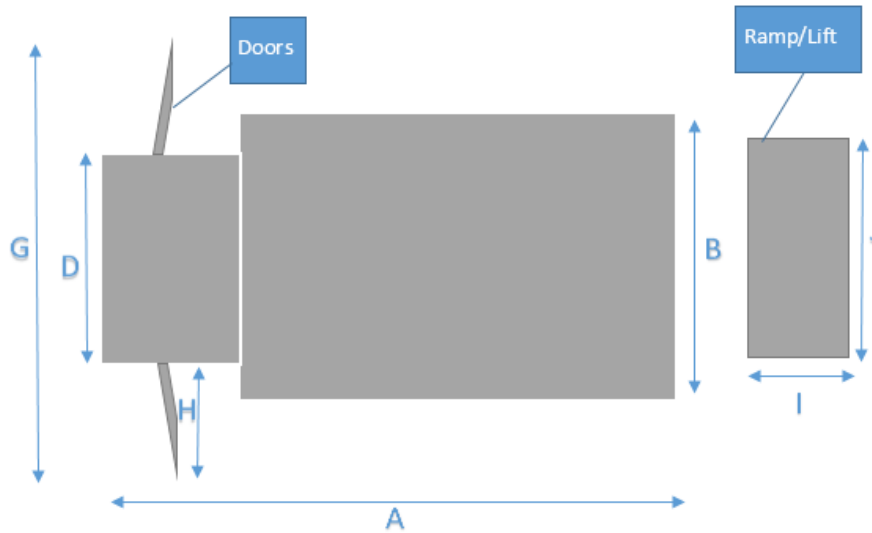

Figure 5.11 Charlie's Produce box truck with lift: open vehicle measurements

Table 5.19 Charlie's Produce box truck with lift: open vehicle measurements

ID	Measurement (in)	Description
A	486.5	Open Footprint, total length
B	98.5	Cargo compartment, width
D	78.5	Cab, length
G	159.5	Open doors, total width
H	40.5	Door, width
I	100.5	Lift gate, width
J	95	Lift gate, length

Step 3 - Charlie's Produce - Box Truck with Lift Active Vehicle Footprint

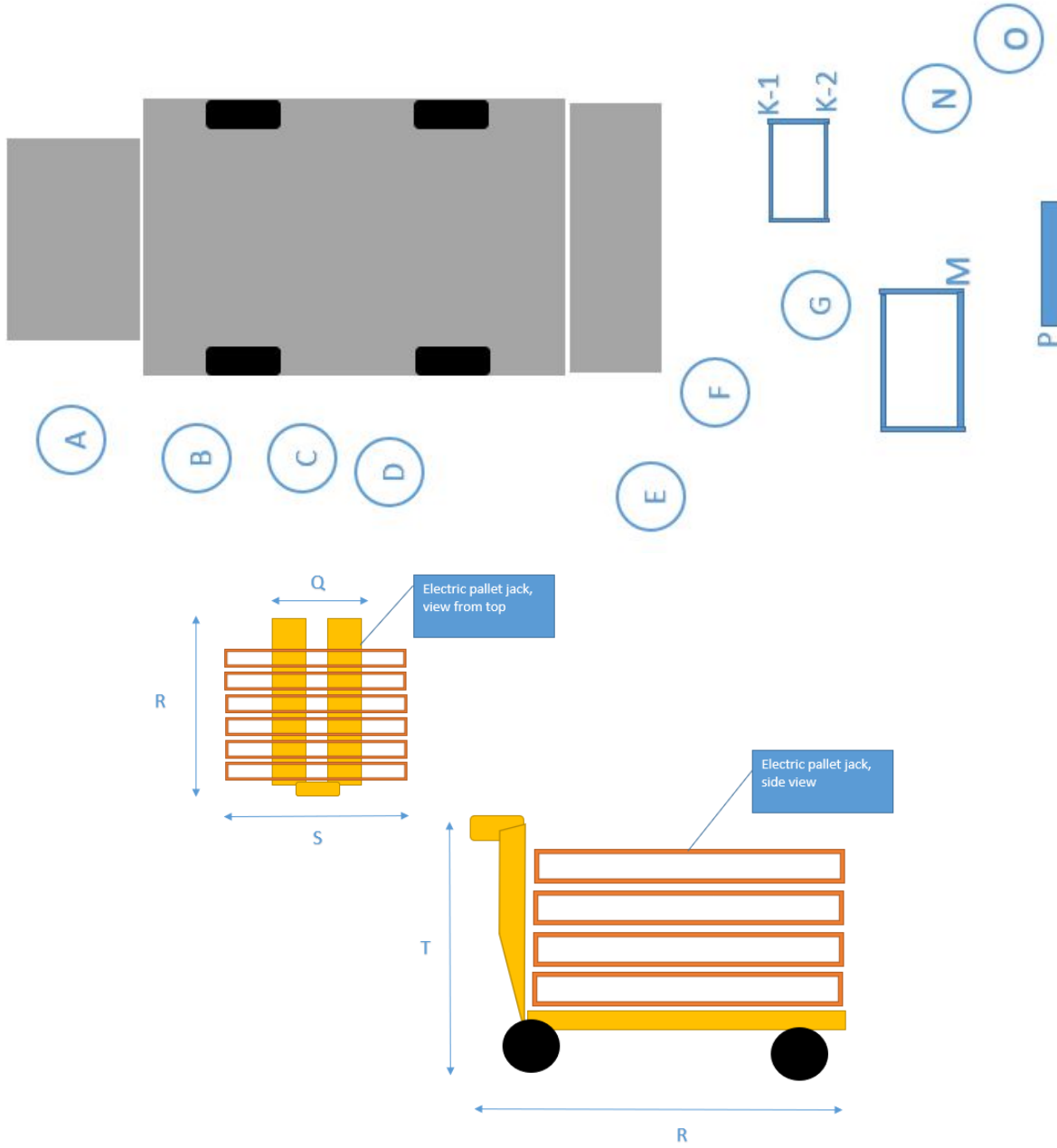

Figure 5.12 Charlie's Produce box truck with lift: delivery movements measurements

Table 5.20 Charlie’s Produce box truck with lift: delivery movements measurements

ID	Measurement (in)	Description
A	10	Need for courier driver
B	29	Want for courier driver
C	15.	Courier driver movement
D	17	Need for courier driver
E	33	Want for courier driver
F	16	Courier driver movement
G	117	Want for courier driver
K-1	115	Edge of hand truck
K-2	166	Edge of hand truck
M	185	Edge of pallet jack
N	211	Need for courier driver
O	213	Want for courier driver
P	208	Desired distance behind the lift gate for courier + accessory movement
Q	30	width, jack only
R	65	length, jack only
S	40	width, jack with pallet
T	55	height, jack only

Step 4 – Charlie’s Produce Interview

After deliveries had been simulated, measured, and recorded, the research team interviewed the courier driver and asked eight questions. The responses are given from the perspective of using a box truck with a ramp, as this is one of the most common vehicle types CP uses for urban deliveries. The responses included in this report are paraphrased from a recording of the interview.

1. What causes the most problems while loading/unloading? Why?

Finding parking is the most challenging part. Sometimes, a CVLZ is occupied by passenger vehicles, and when you call the number listed on the CVLZ sign, the response is slow and ineffective.

Also, the length of the CVLZ is insufficient, and doesn’t usually accommodate the space we need to extend the ramp or to safely/comfortably operate behind the vehicle. It seems like all CVLZs are made for smaller commercial vehicles, like vans. Being able

to extend a ramp would make our deliveries more efficient (because each delivery would be faster).

Bringing goods up over the curb is also a challenge.

2. Is there enough space to comfortably get in and out of your vehicle?

Not right now because you have traffic constantly speeding by you in adjacent transit lanes. You have to watch and wait for traffic to subside in adjacent transit lanes before exiting the vehicle. We then walk as quickly as we can to the back end of the vehicle to access the cargo.

A safe point to exit the vehicle is when there aren't cars nearby, so that it minimizes the risk of a crash. After exiting the cab, we then walk along the side of the vehicle or very close to the vehicle.

3. Is there enough space to maneuver and use this accessory (hand truck)?

Without the ramp, there is usually enough space. If there is at least a 3 feet buffer behind the vehicle without a ramp, then that's sufficient space to comfortably maneuver the hand truck.

4. Mark where you **usually** load/unload goods. Why?

If I am parked at an urban CVLZ along a curb, then this would not be extended, because there is not enough space in the current load zones. I would be up against the back end of the vehicle and loading/unloading behind the vehicle with the hand truck next to me.



5. Mark where you **prefer** to load/unload goods. Why?

I would prefer to be able to extend the ramp at urban CVLZs, and then load/unload the hand truck inside the cargo compartment.

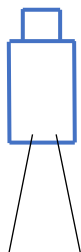

6. What are the most common accessories used with this vehicle type? Why?

A dolly/hand truck because we don't have room for a pallet jack in this vehicle, and a pallet jack would be in our way as we maneuver in the cargo compartment. All we would need is a dolly so that we can either roll it down the ramp, or lift it out onto the pavement and load/unload it there.

7. What infrastructure helps you load/unload? Why? (Infrastructure - the basic, underlying framework or features of a system or organization (1) [e.g., curb cuts, clear pavement markings, curb ramps, visible curb paint, etc.])

Having curb ramps available within CVLZs so that we don't have to bring hand trucks up and over curbs. This would be less stress for us, so that we're not lifting hundreds of pounds over a curb.

8. What would you change about the design of commercial vehicle load zones? Why?

Adding a curb ramp and making the CVLZs longer so that we can make deliveries in a safer manner. Longer CVLZs also improves visibility of what activity is happening in the parking lane behind the vehicle, because it gives me more time to react to an undesirable situation. For example, if the parked vehicle behind my commercial vehicle is hit, then I have more time to react and move from the conflict zone.

9. *Side notes from Discussion* - Parking in a safe manner, and not having to worry about conflicting with pedestrian space is important. Being able to have the ramp extended, and use it in our favor, helps make our deliveries more efficient.

If the curb space next to the CVLZ is obstructed with flower beds, bike shares, fire hydrants, etc., then the courier would go to the closest crosswalk, which would force the courier to walk into traffic. Walking into traffic is undesirable.

If we get injured walking alongside traffic, moving obstructions like a bike, etc., then the courier driver is liable.

5.7 Summary of Research Findings from Simulations

Through the 25 field observations and seven simulated deliveries, three major factors were found to significantly affect the workable range of an operating envelope:

- the driver and passenger door wingspan;
- the delivery type (assisted or unassisted);
- the cargo door type at the back end of the vehicle.

Table 5.21 provides a summary of the vehicles' dimensions.

Table 5.21 Truck footprint summary in centimeters (inches)

Commercial Vehicle Type	Truck Length	Truck Width - with Mirrors	Width with Door Swing or Widest Dimension of Vehicle	Width of One Door
UW Moving services: box truck with lift gate	657 (266)	259 (102)	422 (166)	109 (43)
UW Moving services: box truck with lift gate	937 (396)	269 (106)	422 (166)	104 (41)
UPS: package car with sliding doors	317 (805)	300 (118)	302 (119)	N/A (Sliding door)
UPS: box truck with ramp and lift	1023 (403)	269 (106)	378 (149)	64 (25)
Charlie's Produce: delivery van	236	243 (96)	384 (151)	91 (36)
Charlie's Produce: box truck with ramp	767 (302)	304 (120)	384 (151)	114 (45)
Charlie's Produce: box truck with lift	980 (386)	320 (126)	406 (160)	106 (42)
Maximum Dimension	1023 (403)	300 (118)	422 (166)	109 (43)

This section describes recommendations for a *workable range* of dimensions for an operating envelope to be used in the bicycling simulator study led by the OSU research team, with the goal of refining this range to ultimately provide recommendations for the optimal dimensions of a CVLZ.

5.7.1 Driver and Passenger Door Wingspan/ Widest Dimensions of a Vehicle

The widest point of a commercial vehicle is either the wingspan of the driver and passenger swing out doors fully extended, or if the vehicle does not have swing-out doors (e.g., a UPS package car), then the widest portion of the vehicle itself. The wingspan dimensions also cover the minimum space required along the sides of the vehicle for the courier driver.

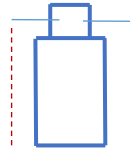

Figure 5.1 Location for width of truck measurement

Table 5.22 contains the minimum and maximum vehicle wingspan measurements of one driver/passenger door from the simulation. These numbers do not include commercial vehicles with sliding doors. These measurements are rounded to the nearest whole number in inches.

Table 5.22 Driver/passenger door width minimum and maximum (inches)

Door Width Minimum	Door Width Maximum
25	45

5.7.2 Delivery Type (*Assisted or Unassisted*)

Depending on how the delivery is completed, the minimum operating envelope will vary. Below, a workable range is discussed for each scenario and for different sides of a commercial vehicle, irrespective of the commercial vehicle class. These measurements are rounded to the nearest whole number in inches.

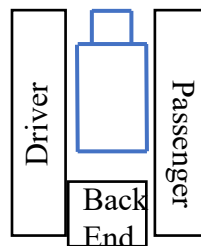

Figure 5.2 Locations for operating envelope measurements

Table 5.23 includes the workable minimum when an accessory is not present on either the driver side, back end, or passenger side. The workable minimum is an average of the measurements that were noted to meet the “need for courier driver, need + want for courier driver, and courier driver movement.” The workable maximum is an average of the measurements that were noted to meet the “want for courier driver.”

Table 5.23 Unassisted workable minimum and maximum (Inches)

Unassisted Delivery	Workable Minimum	Workable Maximum
Driver	25	35
Back End	29	N/A
Passenger	19	46

Table 5.24 shows the workable minimum and maximum for the areas where a hand truck was observed in the simulation. At the back end of the vehicle, the workable minimum is a hand truck at rest behind the vehicle; this distance includes the needs for resting a hand truck at an angle on the vehicle. The workable maximum is the farthest a hand truck was observed to be behind a commercial vehicle. Note that all of these measurements were calculated by assuming that a lift gate was disengaged or not present. On the passenger side, the workable minimum includes the measurements of a hand truck tilted onto the passenger side of a UPS package car and the extra space needed to accommodate the turning radius.

Table 5.24 Hand truck assisted delivery workable minimum and maximum (inches)

One Hand Truck Assisted Delivery	Workable Minimum	Workable Maximum
Back End	51 (resting hand truck at an angle)	66
Passenger	107	N/A

Table 5.25 shows the workable minimum and maximum for the areas where a pallet jack was observed in the simulation. At the back end of the vehicle, the workable minimum is the smallest space needed or wanted behind a commercial vehicle using a pallet jack. The workable maximum is the largest space wanted behind a commercial vehicle with a pallet jack. Both of these measurements exclude the additional space required for a lift gate behind the vehicle. The passenger side is the space the courier driver needs/wants to operate a pallet jack along a commercial vehicle. This measurement captures maneuvering space, pallet jack dimensions, and parcel overhang.

Table 5.25 Pallet jack assisted delivery (inches)

Pallet Jack Assisted Delivery	Workable Minimum	Workable Maximum
Back End	111	179
Passenger	75	N/A

The lift gate of a vehicle is located at the back end of the vehicle, and a commercial vehicle may or may not have this extension as part of its vehicle design. Table 5.26 shows a range of additional widths required behind a vehicle if a lift gate is present. The minimum is the smallest width of the lift gates measured in the simulation, and the maximum is the largest width of a lift gate measured in the simulation. Because utilizing a pallet jack is dependent on having a vehicle with a lift gate, the second set of measurements, Back End – Lift Gate + Pallet Jack Assisted Delivery, adds the workable minimum and maximum of a pallet jack assisted delivery to the lift gate measurements.

Table 5.26 Lift gate minimum/maximum with pallet jack (inches)

Lift Gate Assisted Delivery	Minimum	Maximum
Back End – Lift Gate Only	76	101
Back End – Lift Gate + Pallet Jack Assisted Delivery	187	280

Table 5.27 shows the measurements associated with a delivery using a ramp. Back End – Ramp Only, is the additional space required behind a vehicle for a ramp to extend. Because ramps are often associated with using a hand truck, Back End – Ramp + Hand Truck Assist Delivery, includes the measurements of a ramp and the extra space needed to use (pull weight + turning radius) a hand truck as well.



Figure 5.31 Location for back end measurements

Table 5.27 Ramp minimum with and without hand truck (inches)

Ramp Assist Delivery	Minimum
Back End - Ramp Only	158
Back End - Ramp + Hand Truck Assist Delivery	227

5.7.3 Cargo Door Type at the Back End of the Vehicle

Commercial vehicles have different vehicle designs that affect the amount of space required to operate around the vehicle. One factor that affects the operating envelope is the cargo door type at the back end of the vehicle. These can include a manual lift, roll up, one door opens out, two doors open out, or other. Only two of these door types were measured during the simulation, roll up and two doors open out.

Table 5.28 Back end door type door minimum (inches)

Cargo Door Type Back End of Vehicle	Minimum
Back End - Roll Up	N/A
Back End - Two Door Open Out	31

5.8 Summary

A summary of the envelope dimension is provided in table 5.28. This table covers the delivery types (assisted or unassisted with accessories) and the cargo door types at the back end of the vehicles.

Table 5.29 Envelope dimensions in centimeters (inches)

Delivery Type	Delivery Activity Location and Accessories	Workable Minimum cm (inches)	Workable Maximum cm (inches)
Unassisted Delivery (no accessories)	Side	64 (25)	89 (35)
	Backend	74 (29)	NA
Delivery with hand truck	Back end	130 (51)	168 (66)
	Side	272 (107)	NA
Pallet Jack Assisted Delivery	Back End	282 (111)	454 (179)
	Side	191 (75)	NA
Lift Gate Assisted Delivery	Back End with Lift Gate Only	193 (76)	256 (101)
	Back End with Lift Gate and Pallet Jack Assisted Delivery	475 (187)	711 (280)
Ramp Assisted Delivery	Back End: Ramp Only	401 (158)	N/A
	Back End: Ramp and Hand Truck Assisted Delivery	577 (227)	N/A
Cargo Door Type Back End of Vehicle	Back End: Roll Up door	0 (0)	N/A
	Back End: Door Open Out	79 (31)	N/A

The workable range of dimensions shown in Tables 5.29 ultimately provides recommendations for the optimal envelope dimensions of a CVLZ. The envelope dimensions are added to the footprint of the truck. This footprint is the widest point of a commercial vehicle when the vehicle’s cargo doors are closed, but the CVLZ should account for door swing space. The delivery envelope is this widest portion of the vehicle plus the minimum space required along the sides and back of the vehicle for the courier to complete delivery operations. The workable envelope minimums in the tables are averages of measurements that were noted to be needed for the courier. The workable maximums are averages of the measurements that were desired by couriers, based on observations of the couriers and interviews with them. In a number of cases the minimum and desired distances are the same.

As an example of using these measurements, if our project partner the City of Seattle wanted to install a CVLZ in an area with a number of small restaurants, the following calculations would result in safe and workable CVLZs. The typical truck serving this area is a mid-size class 5 box truck like the Charlie’s Produce box truck, with a ramp like that recorded in table 5.21 as commercial vehicle type “*Charlie’s Produce box truck with ramp.*” (Note: this

truck was also measured in table 5.15). As noted in table 5.21, this truck's closed footprint requires a *truck length* of 302 inches (25 feet) and *truck width with mirrors* of 120 inches (10 feet). As seen in table 5.21, the driver's doors swing out and increase the required *width with door swing or widest dimension of the vehicle* to 151 inches (12 feet 7 inches), so the CVLZ should account for the doors. The minimum and maximum in table 5.21 can be used to add to the truck footprint to develop the truck's delivery envelope. This area of Seattle has many small deliveries, so hand trucks are commonly used in conjunction with a ramp, as opposed to pallet jacks and lift gates. As seen in table 5.29 in the *Ramp Assisted Delivery* row, the use of a ramp adds 227 inches (18 feet 11 inches) to the back of a truck (to provide room for ramp and hand truck maneuvering and turning). An additional 25 inches (from *Unassisted Delivery (no accessories)* in table 5.29) is required for the driver to walk alongside a truck to the back. This would result in a CVLZ with a width of 12 ft and length of 44 ft.

CHAPTER 6. BICYCLE SIMULATOR EXPERIMENT

6.1 Method

The hardware and software associated with the Oregon State University (OSU) bicycle simulator are described below, as well as the types of data that were collected for the bicycling simulator experiment. Additionally, the experimental protocol, including the process for recruitment of subjects, the sequence of activities participants were directed to perform during the experiment, and the pilot study of the experimental protocols are detailed.

6.1.2 Experimental Equipment

The experimental design and established experimental protocols were selected as the most appropriate means to address the research questions of interest. This approach is grounded in accepted practice (Fisher, et al. 2011) and leveraged the unique research capabilities at OSU. The primary tool that was used for this experiment, the OSU bicycling simulator, is described in detail in the following sections.

6.1.2.1 Truck Classes

The Federal Highway Administration (FHWA, 2014) defines thirteen vehicle classes (figure 6.1). For this study, trucks in class 6 of FHWA's vehicle classification framework were considered because this class includes city delivery trucks (Municibid, 2018). Trucks in class 6 supported our intent to simulate an urban environment. As defined by FHWA (2014), this class of three-axle, six-tire, single-unit trucks includes all vehicles on a single frame, such as trucks, camping and recreational vehicles, motor homes, etc., with three axles.





































Class 1 Motorcycles		Class 7 Four or more axle, single unit	
Class 2 Passenger cars		Class 8 Four or less axle, single trailer	
			
			
			
Class 3 Four tire, single unit		Class 9 5-Axle tractor semitrailer	
			
			
Class 4 Buses		Class 10 Six or more axle, single trailer	
			
			
Class 5 Two axle, six tire, single unit		Class 11 Five or less axle, multi trailer	
			
			Class 12 Six axle, multi-trailer
Class 6 Three axle, single unit			
			
			
		Class 13 Seven or more axle, multi-trailer	
			
			

Figure 6.1 FHWA vehicle classification framework (FHWA, 2014)

6.1.2.2 Bicycle Simulator

The OSU bicycling simulator consists of an instrumented urban bicycle placed on top of an adjustable stationary platform. A 10.5-ft × 8.3-ft (3.20-m × 2.54-m) screen provides the forward view with a visual angle of 109° (horizontally) × 89° (vertically) and an image resolution of 1024 × 768 pixels. Researchers build the environment and track subject bicyclists from within the operator workstation shown in figure 6.2, which is out of view of participants in the bicycle simulator experiment.



Figure 6.2 Operator workstation for the bicycling simulator. *Left:* Real-time monitoring of the simulated environment. *Right:* A researcher designing an experiment in SimCreator.

The update rate for the projected graphics is 60 Hz. Ambient sounds around the bicycle are modeled with a surround sound system. The computer system consists of a quad-core host running Realtime Technologies SimCreator Software with an update rate for the graphics of 60 Hz. The simulator software is capable of capturing and outputting highly accurate values for performance measures such as speed, position, brake, and acceleration. Figure 6.3 shows views of the simulated environment created for this experiment from the participant's view (left) and outside view (right).

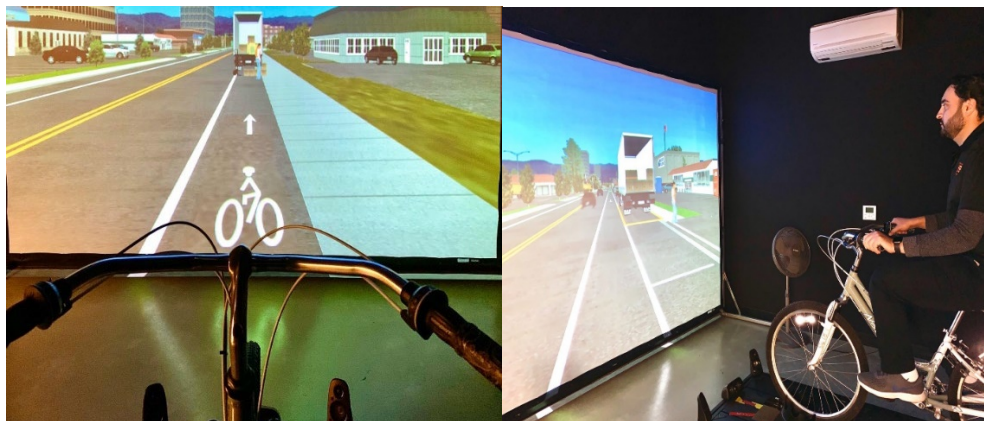

Figure 6.3 Simulated environment in the OSU driving simulator. *Left:* Participant's perspective. *Right:* A researcher testing the environment.

The virtual environment is developed by using simulator software packages that include Internet Scene Assembler (ISA), Simcreator, AutoCAD, Blender, and Google Sketchup. The simulated test track is developed in ISA by using Java Script-based sensors on the test tracks to

display dynamic objects, such as a truck cutting in front of a bicyclist or a pedestrian walking on a sidewalk.

6.1.2.2.1 Simulator Data

The following parameters for both the subject bicycle and dynamic objects were recorded at roughly 10 Hz (10 times a second) throughout the experiment:

- Time – To map the change in speed and acceleration with the position on the roadway;
- Instantaneous speed of subject bicycle – To identify changes in speed approaching a truck envelope;
- Instantaneous position of subject bicycle – To estimate the headways and distance upstream from a truck envelope;
- Instantaneous acceleration/deceleration – To identify any acceleration or deceleration approaching the truck envelope;
- SimObserver data - The bicycling simulator was equipped with three cameras positioned at various viewing angles to observe the actions of participants when approaching the truck envelope. Figure 6.4 shows the various camera views and screen captures that were recorded by SimObserver (Version 2.02.4).



Figure 6.4 Screenshot of the three views from SimObserver. *Left:* Simulated scene as projected on the screen. *Center:* View of the driver's upper body and hands on the handlebar. *Right:* View of the entire simulator platform.

6.1.2.2.2 Simulator Sickness

Simulator sickness is a phenomenon in which a person exhibits symptoms similar to motion sickness caused by a simulator (Fisher et al. 2011; Owens and Tyrrell 1999). The

symptoms and can include headache, nausea, dizziness, sweating, and in extreme situations, vomiting. While there is no definitive explanation for simulator sickness, one widely accepted theory, cue conflict theory, suggests that it arises from the mismatch of visual and physical motion cues, as perceived by the vestibular system (Owens and Tyrrell 1999). There is no literature in the area of bicycling simulation that would suggest motion sickness issues in bicycle simulation experiments. However, precautions were taken to ensure comfort for all of the participants.

6.1.2 Experimental Design

The bicycling simulator experiment examined bicycle interactions with trucks. This examination was achieved by analyzing bicyclist behavior at and around commercial vehicle loading zones (CVLZ). The bicyclists' performance was used to evaluate and understand the safety issues regarding the interaction of bicyclists with commercial vehicle (trucks) loading zones in an urban environment.

6.1.2.1 Factorial Design

Three independent variables were included in the experiment: pavement marking, courier position, and accessory (table 6.1).

Table 6.1 Experimental factors and levels

Variable Name	Level	Levels Description
Pavement Marking	0	No CVLZ – Truck in Bike Lane
	1	Minimum CVLZ – Size of the vehicle only
	2	Recommended CVLZ – Size of the vehicle plus desired operational footprint
Courier Position	0	No Courier
	1	Courier Behind Vehicle
	2	Courier on Driver's Side
Accessory	0	No Accessory
	1	Hand Truck

6.1.2.2 Research Questions

The specific research questions associated with the assessment of the bicyclist performance are presented in this sub-section.

The bicyclists' performance was measured in terms of velocity (m/s) and lateral position (m). The potential influence of the experimental factors (table 6.1) on each of the response variables formed the basis of the research questions regarding the bicyclists' performance.

- *Research Question 1 (RQ1)*: Do CVLZ pavement markings, courier position, and accessory presence have any effect on the bicyclists' velocity in the bicycling environment?
- *Research Question 2 (RQ2)*: Do CVLZ pavement marking, courier position, and accessory presence have any effect on the bicyclists' lateral position in the bicycling environment?

6.1.2.3 Presentation of Bicycling Scenarios

Eighteen scenarios (table 6.2) were presented to participants across five grids. Participants were exposed to a variety of different treatment configurations to measure the influence of each treatment alternative.. Figure 6.5 shows the built environments with different treatments.

Table 6.2 Scenarios

Experiment #	Event #	Pavement Marking	Courier Position	Accessory
Grid 1				
15	1	Preferred CVLZ	Courier behind vehicle	No Accessory
8	2	Minimum CVLZ	No Courier	Hand Truck
1	3	No Marking	No Courier	No Accessory
Grid 2				
18	1	Preferred CVLZ	Courier on side	Hand Truck
7	2	Minimum CVLZ	No Courier	No Accessory
3	3	No Marking	Courier behind vehicle	No Accessory
Grid 3				
5	1	No Marking	Courier on side	No Accessory
12	2	Minimum CVLZ	Courier on side	Hand Truck
9	3	Minimum CVLZ	Courier behind vehicle	No Accessory
13	4	Preferred CVLZ	No Courier	No Accessory
Grid 4				

Experiment #	Event #	Pavement Marking	Courier Position	Accessory
11	1	Minimum CVLZ	Courier on side	No Accessory
14	2	Preferred CVLZ	No Courier	Hand Truck
6	3	No Marking	Courier on side	Hand Truck
16	4	Preferred CVLZ	Courier behind vehicle	Hand Truck
Grid 5				
2	1	No Marking	No Courier	Hand Truck
17	2	Preferred CVLZ	Courier on side	No Accessory
4	3	No Marking	Courier behind vehicle	Hand Truck
10	4	Minimum CVLZ	Courier behind vehicle	Hand Truck

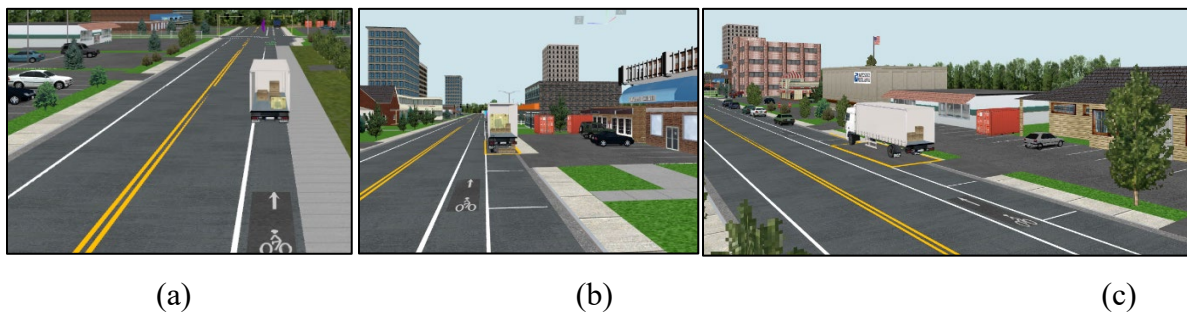

Figure 6.5 Example of a) no loading zone, b) minimum loading zone size, and c) maximum loading zone

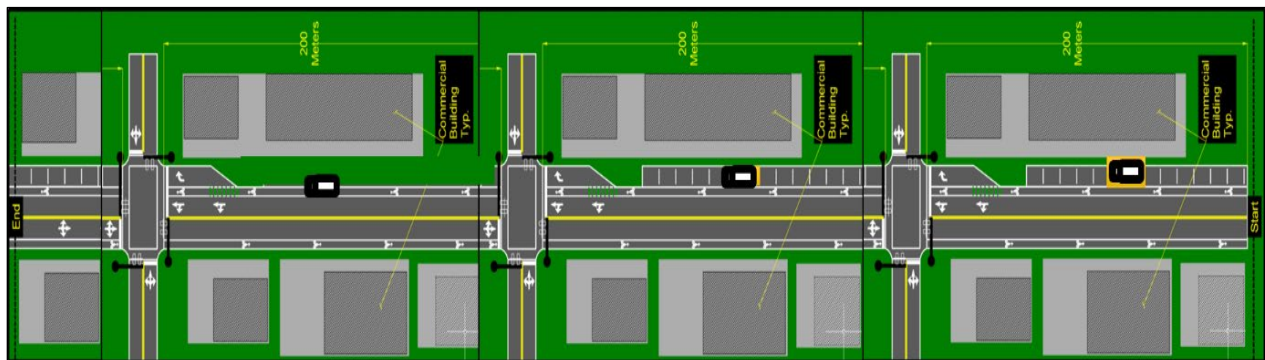

Figure 6.6 Layout of Grid 1

Figure 6.6 shows an example grid layout. Participants began at the start line and rode through three or four loading zones. The bicyclist was prompted to stop pedaling at the finish line, at which point the researcher terminated the simulation.

6.1.2.4 Counterbalancing

The order of intersection grids was counterbalanced to control for practice or carryover effects. In this randomized partial counterbalancing procedure, five different grid sequences were chosen. The grid sequences were randomized for each participant.

6.1.3 Bicycling Simulator Experimental Protocol

This section describes the step-by-step procedures of the bicycling simulator study, as it was conducted for each participant.

6.1.3.1 Recruitment

Participants in this study were selected on the basis of the typical demographic of the bicyclist population available through researcher contacts at bicycle clubs and non-motorized user and demographic surveys completed by regional and national transportation departments. All participants were required to have the experience of riding a bicycle and be physically and mentally capable of appropriately controlling a bicycle. All participants had to be competent to provide informed consent, and bicycling simulator subjects could not have vision problems that would prevent them from participation in this study. Participants were excluded if they used glasses while cycling; however, contact lenses were acceptable.

The simulator study had a maximum enrollment of 50 participants, 25 males and 25 females. Researchers did not screen interested participants on the basis of gender until the quota for either males or females had been reached, at which point only the gender with the unmet quota was allowed to participate. Although it was expected that many participants would be OSU students because of the lab's location on the OSU campus, an effort was made to incorporate participants of all ages within the specified range of 18 to 89. Throughout the entire study, information related to the participants were kept under double-lock security in compliance with accepted Institutional Review Board (IRB) procedures. Each participant was randomly assigned a number to remove any uniquely identifiable information from the recorded data.

6.1.3.2 Informed Consent and Compensation

Upon the test participant's arrival to the laboratory, the informed consent document approved by OSU's IRB 8506 was presented and explained. This provided the participant with the opportunity to have an overall idea of the entire experiment and to ask any questions regarding the test. The informed consent document includes the reasoning behind the study and the importance of the participant's participation. In addition, the document explained the test's

risks and benefits to the participant. Participants were given \$20 compensation in cash for participating in an experimental trial after signing the informed consent document.

6.1.3.3 Prescreening Survey

The second step of the simulator test was a prescreening survey targeting participants' demographics, such as age, gender, driving/bicycling experience, highest level of education, and also previous experience with driving/bicycling simulators and motion sickness. In addition to the demographic information, the survey included questions in the following areas:

- Vision – Participants' vision was crucial for the test. The survey asked participants whether they used corrective glasses or contact lenses while driving/bicycling. This ensured during the test ride that the participants could clearly see the bicycling environment and read the visual instruction displayed on the screen to stop the bicycling.
- Simulator sickness – The survey asked participants with previous driving/bicycling simulation experience about any simulator sickness they experienced. If they had previous experience with simulator sickness, they were encouraged not to participate.
- Motion sickness – The survey asked participants about any motion sickness they had experienced in the past. If an individual had a strong tendency toward any motion sickness, they were encouraged not to participate in the experiment.

6.1.3.4 Calibration Ride

A test ride followed the completion of the prescreening survey. At this stage, bicyclists performed a one- to two-minute calibration ride to acclimate to the operational characteristics of the bicycling simulator and to confirm whether they were prone to simulator sickness. Participants were instructed to ride and follow all traffic laws that they normally would. The test ride was conducted on a generic city environment track similar to this experiment so that participants could become accustomed to both the bicycle's mechanics and the virtual reality of the simulator (figure 6.7). In the case that a participant reported simulator sickness during or after the calibration ride, they were excluded from the experimental rides.



Figure 6.7 Calibration ride in simulation

6.1.3.5 Experimental Ride

Participants were given brief instructions about the test environment and the tasks they would be required to perform. The experiment was divided into five grids. The virtual bicycling course itself was designed to take the participant 20 to 30 minutes to complete. The entire experiment, including the consent process, and post-ride questionnaire, lasted approximately 50 minutes.

6.1.3.6 Simulator Data

Simulator data were collected from the bicycling simulator and *SimObserver* platform during the experiment. A complete data file was generated for each participant for each of the five experimental rides. Files, including collected video data and all output of bicycle characteristics (e.g., lateral position and velocity), were opened in the *Data Distillery* (Version 1.34) software suite, which provided quantitative outputs (numerical and graphical) in combination with the recorded video. Figure 6.8 shows the *SimObserver* video output in conjunction with numerical data (right side) and graphical representations of data in columns (bottom) opened by *Data Distillery*.

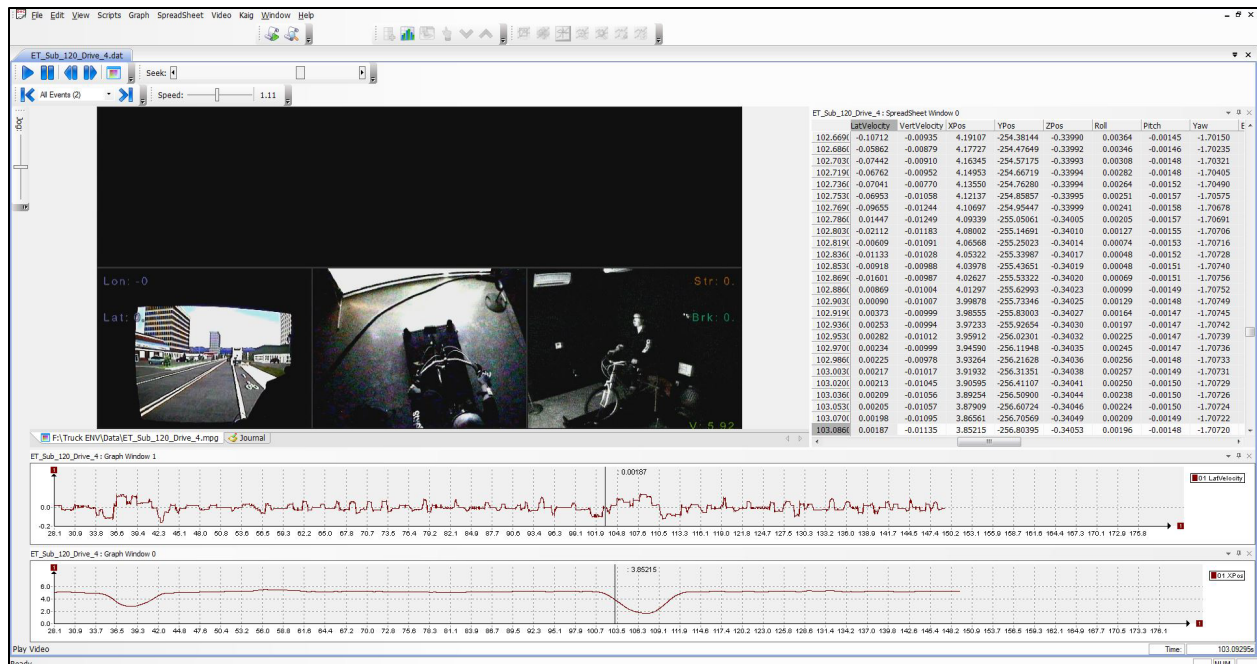

Figure 6.8 Screenshot of the *Data Distillery* software interface

6.2 Results

This section presents the results of the simulator experiment. Section 6.2.1 describes participant demographics. Section 6.2.2 investigates bicyclist’s performance in terms of velocity and lateral position.

6.2.1 Participants

Study participants were recruited from the community in and around Corvallis, Oregon.

6.2.1.1 Summary Statistics

The simulator experiment was successfully completed by 50 participants, including 25 women ($M_{age} = 29.84$, $SD_{age} = 7.48$) and 25 men ($M_{age} = 36.04$, $SD_{age} = 15.57$). Table 6.3 shows participants’ bicycling habits. Participants most frequently bicycled weekly 1 to 5 miles (22.0 percent) and 5 to 10 miles (22.0 percent) and for recreation (34.7 percent) and exercise (33.7 percent). Additionally, over 68 percent of participants classified themselves as “enthusied and confident” cyclists.

Table 6.3 Participant bicycling habits

Bicycling Habit	Possible Responses	Number of Participants	Percentage of Participants
Bicycling Mileage Per Week	Never	6	12.0%
	Less than 1 mile	7	14.0%
	1-5 miles	11	22.0%
	5-10 miles	11	22.0%
	10-20 miles	8	16.0%
	20-50 miles	6	12.0%
	50+ miles	1	2.0%
Type of Cyclist	Strong and Fearless	5	10.0%
	Enthused and Confident	34	68.0%
	Interested but Concerned	11	22.0%
	No Way No How	0	0.0%
Riding Purpose	Commuting to work/school	30	30.6%
	Recreation	34	34.7%
	Exercise	33	33.7%
	None	1	1.0%

6.2.1.2 Demographics

Every effort was made to recruit a representative sample of Oregon bicyclists. Table 6.4 summarizes self-reported demographic data of the final sample population.

Table 6.4 Participant demographics

Demographics	Categories	Number of Participants	Percentage of Participants
Age	18 – 24 years	11	22.0%
	25 – 34 years	21	42.0%
	35 – 44 years	13	26.0%
	45 – 54 years	1	2.0%
	55 – 59 years	0	0.0%
	60 – 64 years	1	2.0%
	65 – 74 years	3	6.0%
Gender	Female	25	50.0%
	Male	25	50.0%

Demographics	Categories	Number of Participants	Percentage of Participants
Education	High school diploma or GED	3	6.0%
	Some College	8	16.0%
	Trade/vocational school	1	2.0%
	Associate degree	2	4.0%
	Four-year degree	9	18.0%
	Master's Degree	23	46.0%
	PhD Degree	4	8.0%
Race	Asian	7	14.0%
	Black or African American	2	4.0%
	White or Caucasian	33	66.0%
	Other	3	6.0%
	Hispanic or Latino	4	8.0%
Income	Less than \$25,000	10	20.0%
	\$25,000 to less than \$50,000	15	30.0%
	\$50,000 to less than \$75,000	7	14.0%
	\$75,000 to less than \$100,000	10	20.0%
	\$100,000 to less than \$200,000	5	10.0%
	Prefer not to answer	3	6.0%

6.2.1.3 Post-Ride Survey Results

After participants had completed the bicycling simulator portion of the experiment, they were asked to complete a short survey regarding the bicycle simulator functionality and the scenarios they encountered during their ride in the simulator. Results from the survey items were reported. To verify the authenticity of the simulated bicycling task, participants were asked to subjectively evaluate the performance of the bicycle simulator. The ratings ranged from 0 to 100, where 0 was defined as completely different from real-world experience, and 100 was defined as entirely like real-world experience. The average score for this question was 75.08.

Evaluating whether bicyclists had ever experienced specific scenarios and how they felt in them was another goal of the research. To investigate these questions, bicyclist comfort was

evaluated in the post-ride survey. Participants were asked whether they had ever ridden in a bike lane before that had commercial vehicle conflicts.

As shown in figure 6.9, 40 participants (80 percent) indicated that they had experienced the conflict before, while eight participants (16 percent) stated that they hadn't experienced the conflicts before, and two participants (4 percent) were unsure. Following this, participants were asked how comfortable they felt while riding in the bike lane with commercial vehicle conflicts occurring. The average score for this question was 51.58, indicating a close split between participants who both felt less and more comfortable riding in this scenario.

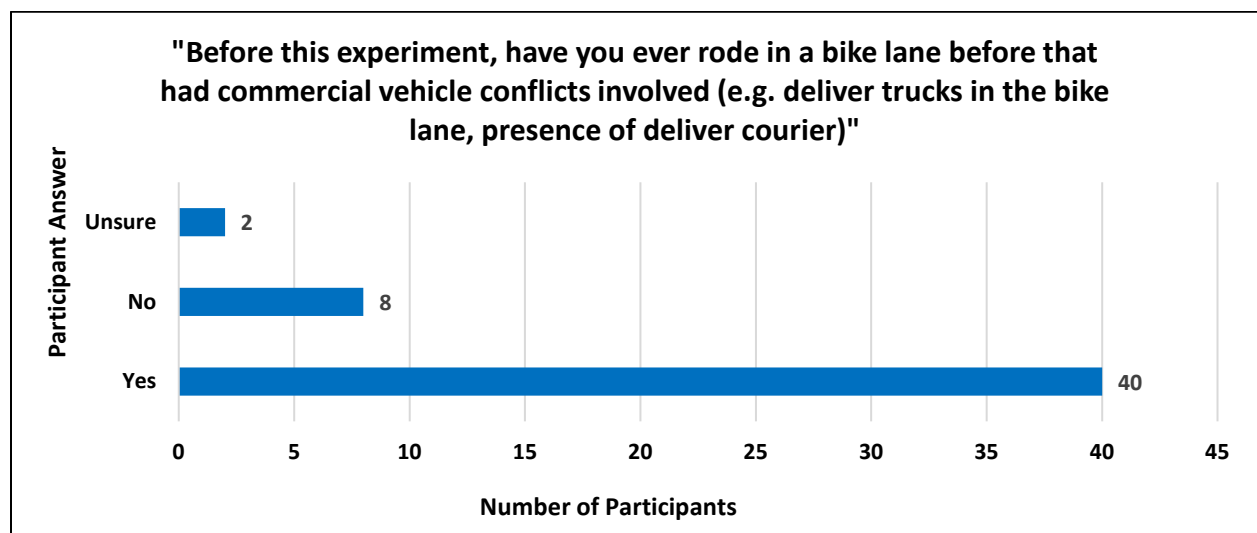

Figure 6.9 Participants' experience with riding in bike lane with commercial vehicle conflict

Individuals were then asked in which scenario they felt most comfortable. Forty-five participants (90 percent) indicated that they felt most comfortable with "the commercial vehicle far from the bike lane (wider loading zone)", followed by four participants (8 percent) indicating "the commercial vehicle adjacent to the bike lane (narrow loading zone)" and one participant (2 percent) indicating "the commercial vehicle in the bike lane (no loading zone)" (figure 6.10).

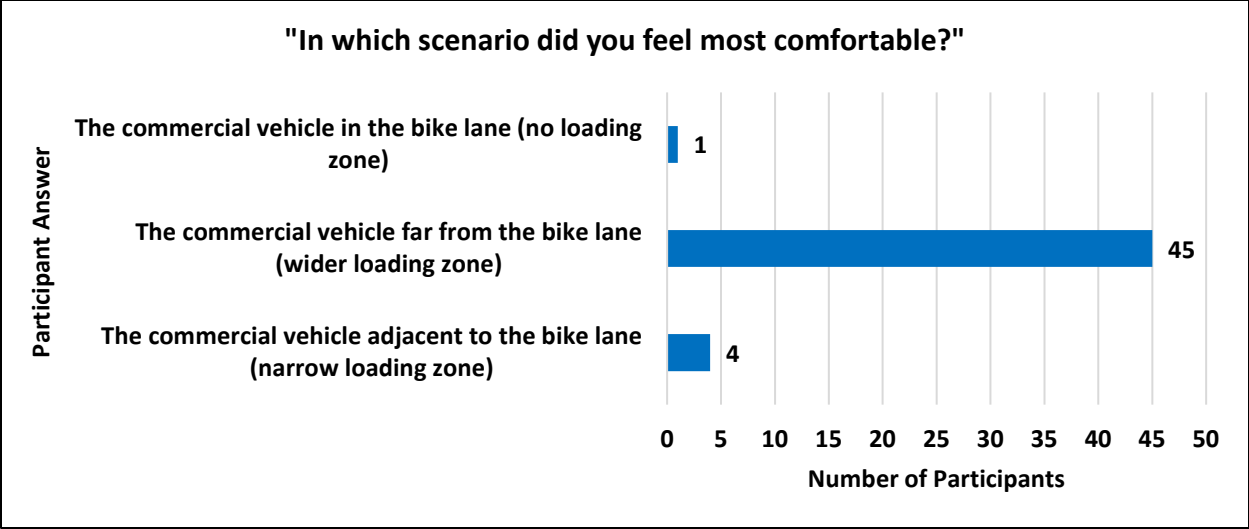

Figure 6.10 Participants’ most comfortable scenario

Participants were then asked if they had ever come upon an obstruction in the bike lane while riding. As shown in figure 6.11, 45 participants (90 percent) indicated that they had experienced an obstruction in the bike lane before, while five participants (10 percent) stated that they hadn’t experienced an obstruction in the bike lane while riding. Following this, participants were asked how comfortable they felt while riding in the bike lane with an obstruction. The average score for this question was 56.08, indicating a close split between participants who felt less and more comfortable riding in this scenario.

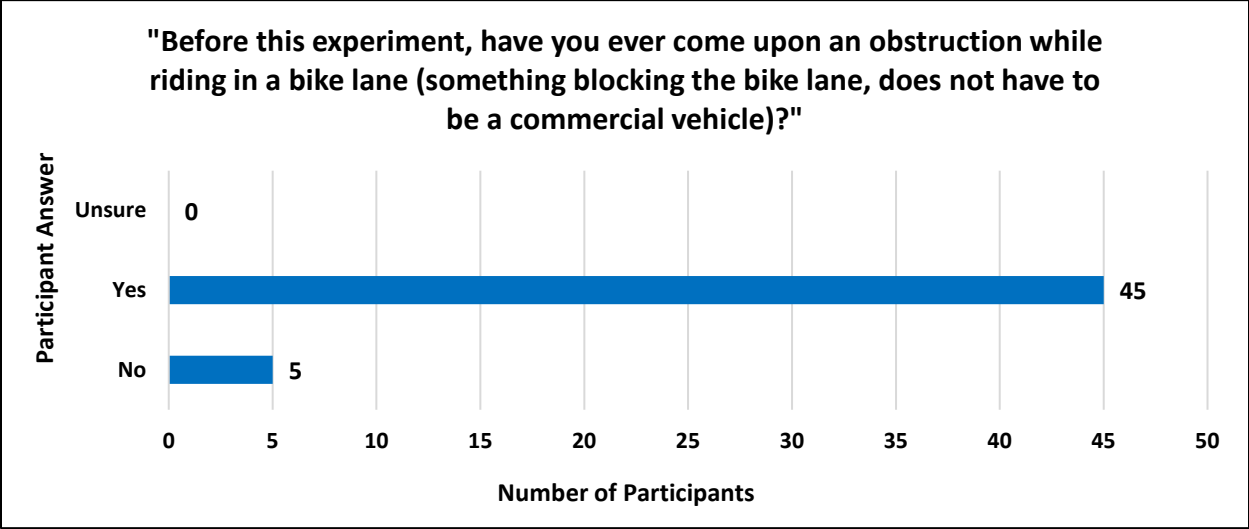

Figure 6.11 Participants’ experience with obstruction in the bike lane while riding

As a follow-up to the obstruction questions, participants who had indicated that they had experienced an obstruction in the bicycle lane were presented two additional questions regarding their experience with obstructions in the bike lane and their typical responses to avoiding them when in the bike lane.

As shown in figure 6.12, out of the 45 participants who answered “yes” to having experienced obstructions in the bike lane, 39 participants (87 percent) indicated that they took actions to avoid the obstruction in the simulator that were similar to those they had taken in real-world conditions. Four participants (9 percent) indicated that they took different actions in the simulator than they had taken in the real world to avoid the obstruction, and two participants (4 percent) indicated that they were unsure. Following this, participants were asked their typical responses to avoiding obstructions in the bike lane.

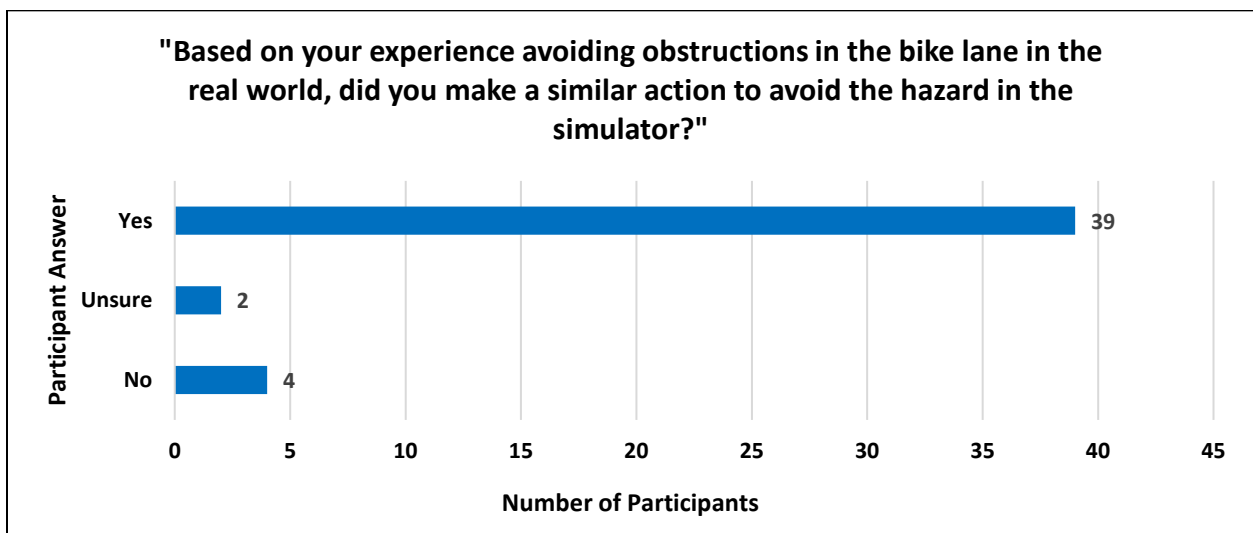

Figure 6.12 Participants’ decision to make similar action to avoid hazards in the real world

As shown in figure 6.13, “take the travel lane (ride in the travel lane)” had the highest response rate (29 participants), followed by “ride between obstruction and traffic,” which was selected by 26 participants. Very few participants selected “stop your bike and wait for obstruction to clear” and “dismount your bike and walk around obstruction,” with only seven and four participants indicating them, respectively.

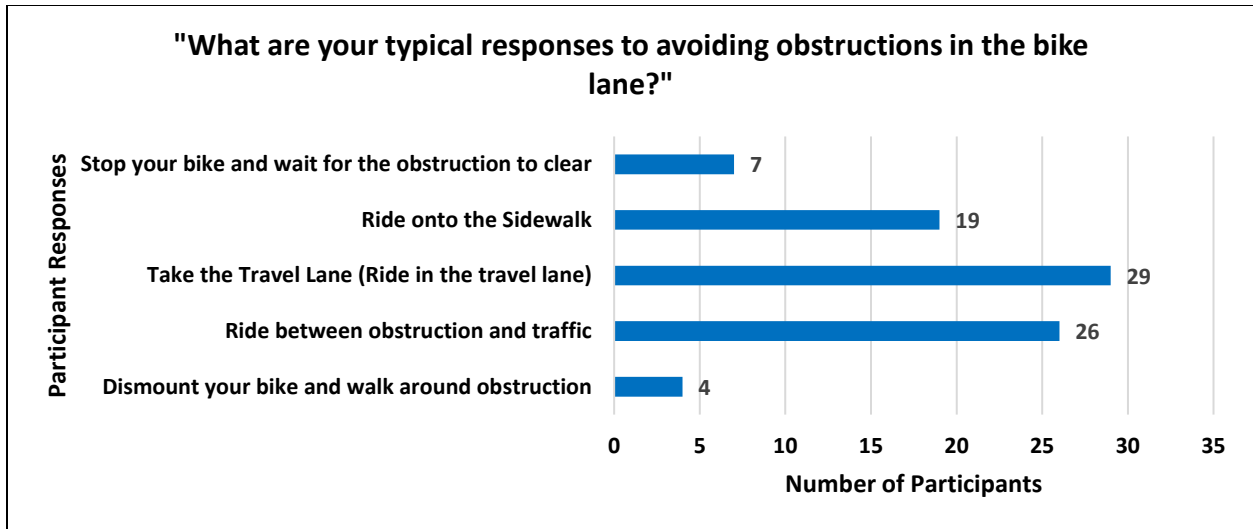

Figure 6.13 Participants' typical responses to avoiding obstructions in the bike lane

6.2.2 Bicycle Performance

A Linear Mixed-Effects Model (LMM) model was chosen for analysis for the following reasons:

- it could handle the errors generated from repeated subject variables as the participants were exposed to all scenarios,
- it could handle fixed or random effects,
- categorical and continuous variables could easily be accommodated, and
- the probability of Type I error occurring would be low (Jashami et al. 2019).

A potential limitation of LMM is that more distributional assumptions need to be addressed (Maruyama, 2008). The sample size for this study was 50 participants, which was greater than the minimum required for a LMM analysis (Barlow et al, 2019). Therefore, the LMM was chosen to model the data and was formulated as follows:

$$y_{ij} = \beta_0 + \beta_1 X_{ij} + b_{i0} + b_{i1} X_{ij} + \varepsilon_{ij} ,$$

$$b_{i0} \sim \text{iid } N(0, \sigma_0^2),$$

$$b_{i1} \sim \text{iid } N(0, \sigma_1^2),$$

$$\varepsilon_{ij} \sim \text{iid } N(0, \sigma_\varepsilon^2).$$

where β_0 is the intercept at the population level, β_1 is the slope (both are for the fixed effect), b_{i0} is the random intercept of the i^{th} participant, and b_{i1} is the random slope for the same

participant, which follow a mean normal distribution with variances $\sigma_{b_0}^2$ and $\sigma_{b_1}^2$ respectively. ε_{ij} is the error term. Hence, (b_{i0}, b_{i1}) and ε_{ij} are assumed to be independent. The model was developed by using the statistical software Minitab for Windows (version 19.1) to consider the independent variables of loading zone size, courier position, and accessories. These variables were included in the model as fixed effects. The participant variable was also included in the model as a random effect.

6.2.2.1 Lateral position

The mean (M) and standard deviation (SD) values for the lateral position for each independent variable level are reported in table 6.5. The center of the bike lane was defined as 0 m, making the left edge -0.92 m (travel lane side). The most divergence ($M_{Lateral} = -1.88$ m, $SD_{Lateral} = 0.51$ m) from the center of the bike lane toward the travel lane was seen with bicyclists encountering a truck in the bike lane (no loading zone), a courier walking beside the truck, and a hand truck with some boxes present behind the truck. On the other hand, bicyclists showed the least divergence ($M_{Lateral} = -0.15$ m, $SD_{Lateral} = 0.15$ m) when a truck was parked in the largest loading zone, no courier was present, and accessories were behind the truck.

Table 6.5 Mean and standard deviation of lateral position (m) at the independent variable level

Loading Zone Size (LZ)	Descriptive Statistics	No Accessories			Hand Truck		
		No Courier	Behind	Beside	No Courier	Behind	Beside
No LZ	M (SD)	-1.47 (0.50)	-1.65 (0.52)	-1.58 (0.61)	-1.61 (0.47)	-1.75 (0.51)	-1.88 (0.51)
Min LZ	M (SD)	-0.25 (0.15)	-0.31 (0.14)	-0.51 (0.33)	-0.28 (0.21)	-0.38 (0.19)	-0.53 (0.40)
Max LZ	M (SD)	-0.17 (0.14)	-0.23 (0.17)	-0.20 (0.20)	-0.15 (0.15)	-0.18 (0.19)	-0.26 (0.16)

An LMM was used to estimate the relationship between the independent variables and participant's mean lateral position, which was appropriate given the repeated measures nature of the experimental design, in which each participant experienced each scenario (Cnaan et al., 1997). Both fixed and random effects needed to be included in the model. In the case of statistically significant effects, custom post hoc contrasts were performed for multiple

comparisons by using Fisher’s Least Significant Difference (LSD). All statistical analyses were performed at a 95 percent confidence level. Restricted maximum likelihood estimates were used in development of this model.

The results of the model are shown in table 6.6. The random effect was significant (Wald $Z=4.37, p < 0.001$), which suggested that it was necessary to treat the participant as a random factor in the model.

Table 6.6 Summary of estimated models for lateral position

Variable	Levels	Estimate	DF	P
Participant random effect (SD)	-	(0.20)	-	<0.001*
Constant	-	-0.74	47	<0.001*
Loading Zone Size	Max LZ	0.37	799	<0.001*
	Min LZ	0.55	799	<0.001*
	No LZ	Base	-	-
Courier Position	Beside	-0.08	799	<0.001*
	Behind	-0.007	799	0.616
	No Courier	Base	-	-
Accessories	AC	-0.04	799	<0.001*
	No Acc	Base	-	-
LZ x CP	Max LZ x Beside	0.05	799	0.006*
	Min LZ x Beside	Base	-	-
LZ x AC	No LZ x Ac	-0.06	799	<0.001*
	No LZ x No	Base	-	-
Summary Statistics				
Adjusted R ²	86%	Observations	864	
-2Log Likelihood	500.93	Participants	48	
AIC	504.95	Observations/Participant	18	

*Significant at the 95% confidence level

All three independent variable characteristics were found to have a significant impact on the lateral position of the bicyclists (figure 6.14). Regardless of the courier position and accessories, a bicyclist encountering a parked truck in the maximum loading zone diverged the least in comparison to the minimum loading zone or no loading zone ($p < 0.001$). The second significant variable was courier position. When bicyclists rode in a scenario that had a courier on

the side of truck, the participants diverged about 0.2 m more than in the no courier condition ($p < 0.001$). However, when the courier was behind the truck, divergence was not statistically different from the no courier scenario. Finally, the accessories variable revealed that the average bicyclist's divergence was 0.08 m more when a hand truck and boxes were present than when they were not ($p < 0.001$). Figure 6.14 plots the mean lateral position for each level of loading zone size, courier position, and accessories.

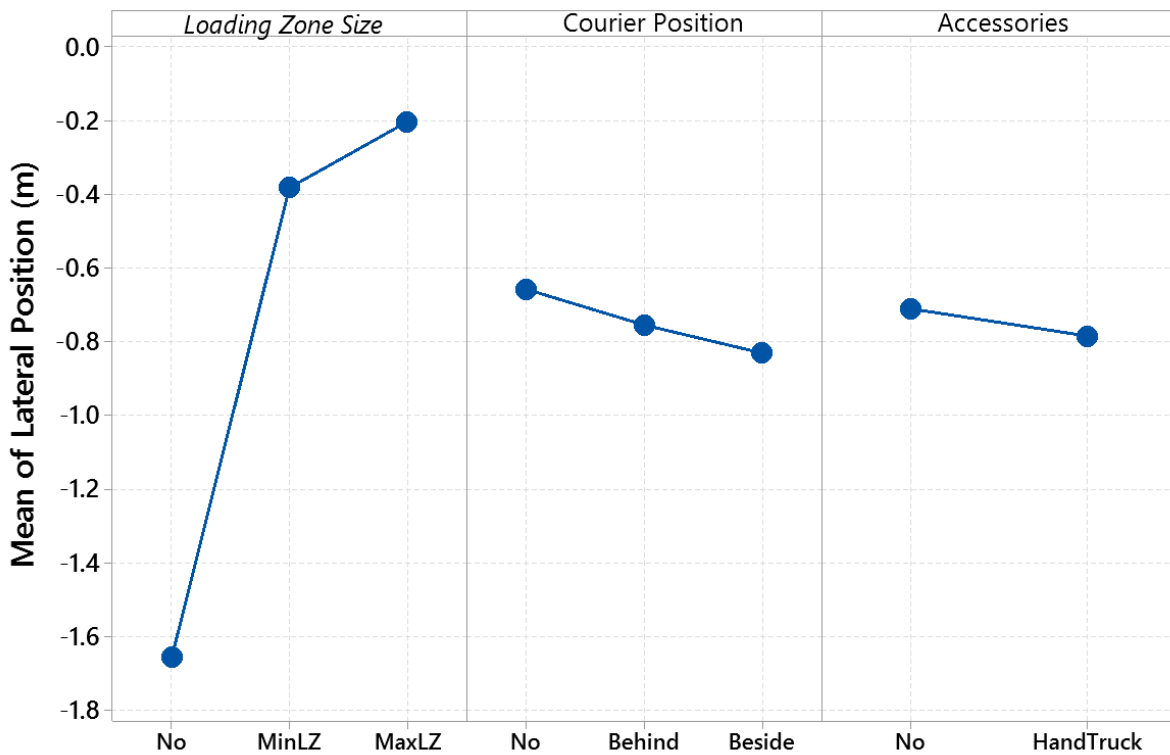

Figure 6.14 Primary effects plot of the selected factors on mean lateral position

Moreover, the LMM revealed two statistically meaningful two-way interactions between loading zone size and both courier position ($p = 0.006$) and accessories ($p = 0.049$), as shown in figure 6.15.a and figure 6.15.b, respectively. However, the interaction term between courier position and accessories was not significant (figure 6.15.c). In figure 6.15, the y-axis shows mean lateral position. The x-axis in plots 6.15.a and 6.15.b shows the three levels of loading zone size treatment, and the x-axis in 6.15.c shows the two levels of accessories treatment. For example, Figure 6.15.a plots the interaction between the levels of loading zone size and courier position. Regardless of accessories, on average, participants diverged more toward the travel lane

with a minimum loading zone than with a maximum loading zone when the courier was walking alongside the truck. Meanwhile, with the courier position held constant with no loading zone, bicyclists diverged less with no accessories present than with accessories. Additionally, the three-way interaction between the three treatment variables was not significant ($p > 0.05$). All treatment factors were inspected by pairwise comparison.

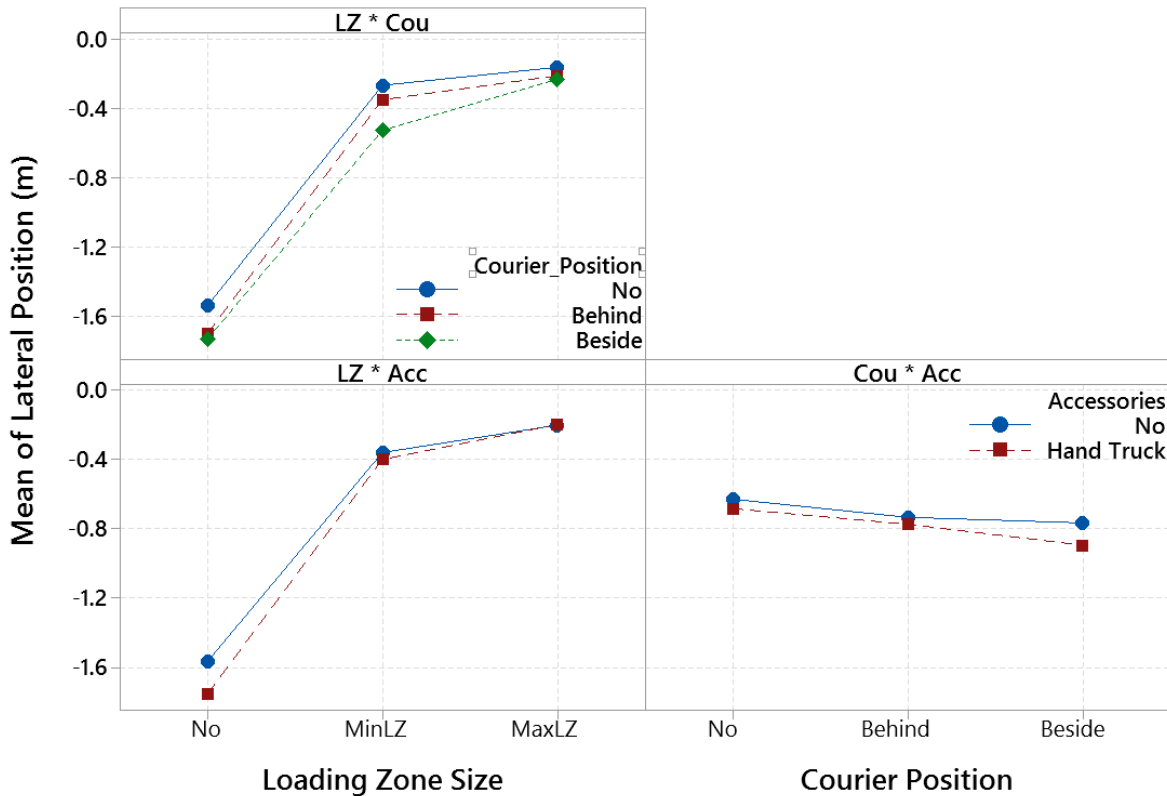
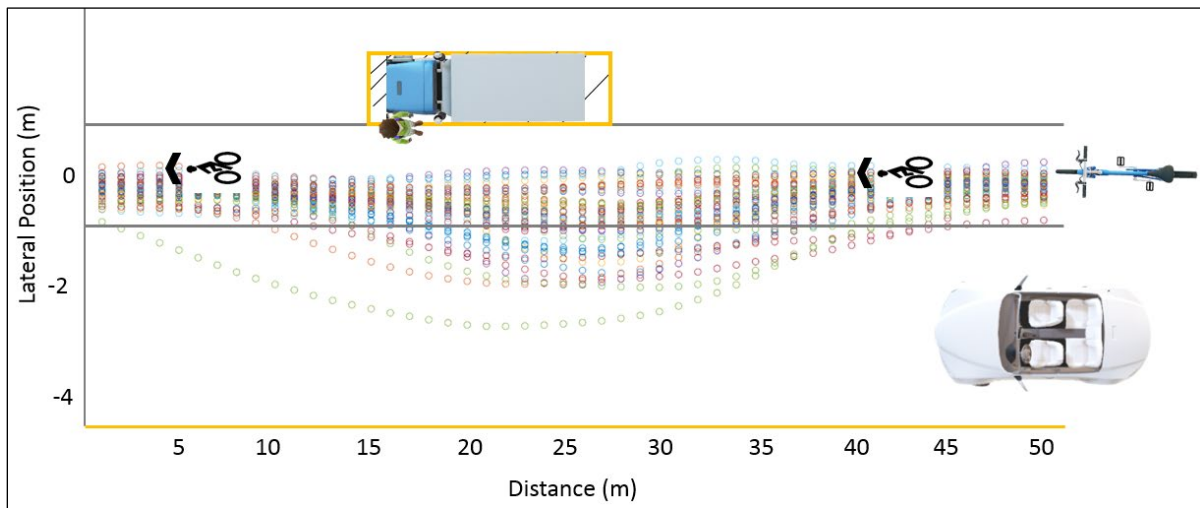
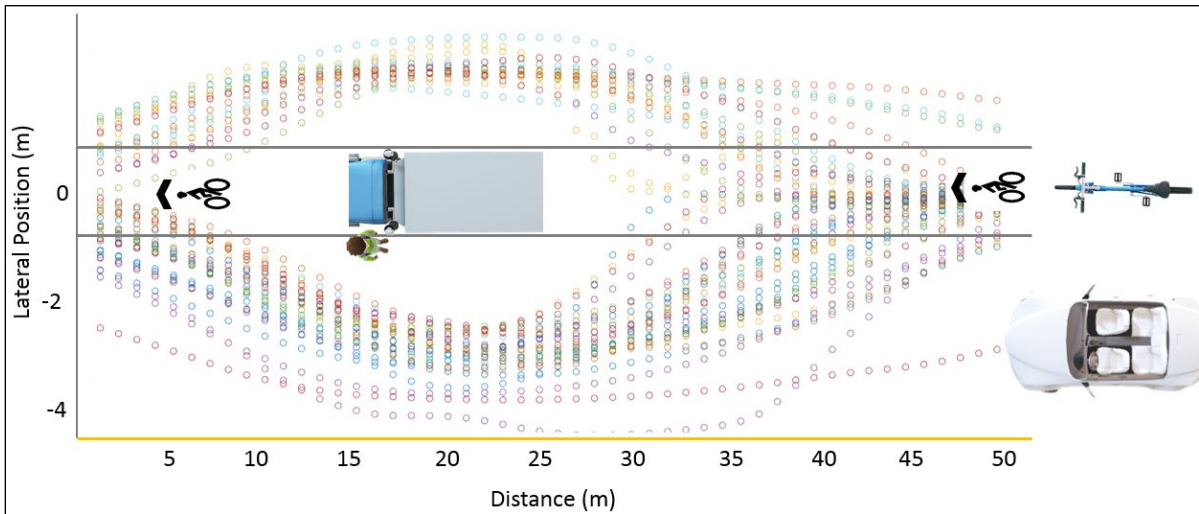

Figure 6.15 Two-way interactions of treatment variables on mean lateral position: a) two-way interactions plot between loading zone size and courier position, b) two-way interactions plot between loading zone size and accessories, and c) two-way interactions plot between courier position and accessories.

Figure 6.16 plots the lateral position distribution (m) on the y-axis, aggregated at each 1 meter at different loading zone sizes (truck was parked in the bike lane, truck was parked in an on-street parking zone, and truck was parked in the desired loading zone) without accessories and with a courier alongside the truck to further explore the influence of the most impactful treatments on the bicyclist's divergence. The x-axis shows traveled distance along the bike lane. The dots indicate the data point of each bicyclist (for all 48 participants). As shown in this figure, loading zone size had an increasing effect on mean lateral position, with a parked truck in the

bike lane resulting in the greatest divergence from the center of the bike lane toward the travel lane. Note that 18 bicyclists out of 48 decided to take the sidewalk instead of the travel lane, but this scenario did not happen when the truck was parked in the on-street parking (Min LZ). For the minimum loading zone, several participants diverged from the bike lane, and this due to the courier position, as they tried to avoid a courier.



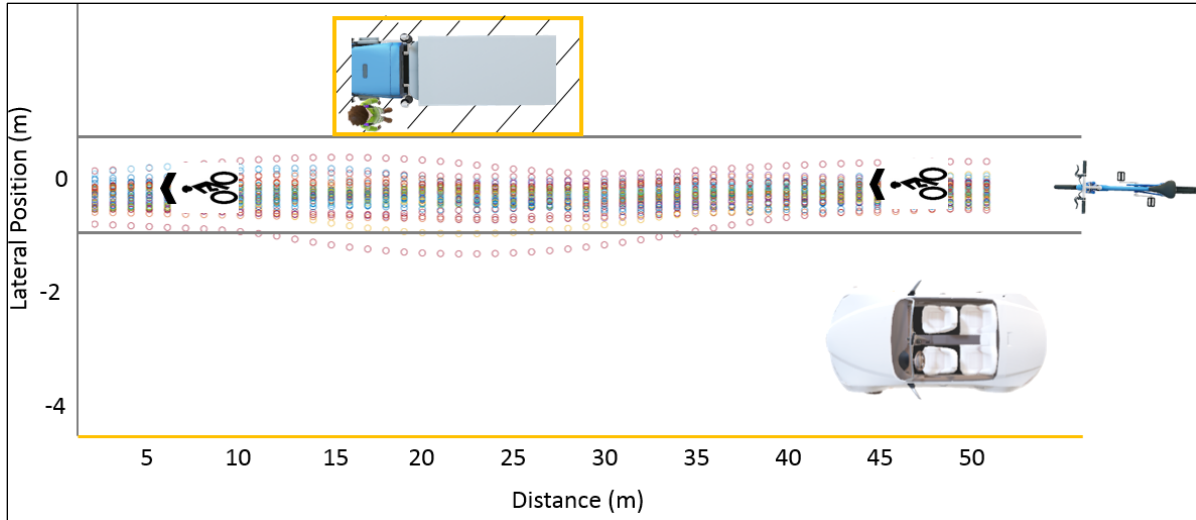

Figure 6.16 Bicyclists’ lateral position at different loading zone sizes with a courier on the side

6.2.2.2 Speed

For each scenario, the average speed (m/sec) of bicyclists from 25 meters before the parked truck to 15 meters after was recorded. Table 6.7 shows the mean (μ) and standard deviation (SD) values for speed for each level of every independent variable. As shown in the table, the highest mean speed occurred with the desired loading zone, and when no couriers and accessories were present ($\mu = 6.32$, $SD = 0.96$ m/sec). The lowest mean speed occurred with the no loading zone and accessories scenario while the courier was on the side of the truck ($\mu = 5.23$, $SD = 1.35$ m/sec).

Table 6.7 Mean and standard deviation of speed (m/sec) at independent variable level

Loading Zone Size (LZ)	Descriptive Statistics	No Accessories			Hand Truck		
		No Courier	Behind	Beside	No Courier	Behind	Beside
No LZ	M (SD)	5.53 (1.06)	5.74 (1.12)	5.23 (1.35)	5.59 (1.13)	5.76 (0.95)	5.70 (1.03)
Min LZ	M (SD)	6.29 (0.84)	6.27 (0.99)	5.40 (0.94)	6.16 (0.83)	6.25 (0.79)	5.63 (1.11)
Max LZ	M (SD)	6.32 (0.96)	5.92 (0.85)	5.96 (0.78)	6.23 (0.82)	6.19 (0.77)	6.03 (0.84)

A modeling approach similar to the one that was followed for the lateral position was used to examine differences in mean speed. The results of the model are shown in table 6.8. The

LMM for a commercial vehicle loading zone showed that all treatment factors (loading zone size, courier position, and accessories) were statistically significant and thus had an influence on bicyclists' speed at the 95 percent confidence level.

Table 6.8 Summary of estimated models for speed (m/sec)

Variable	Levels	Estimate	DF	P
Participant random effect (SD)	-	(0.68)	-	<0.001*
Constant	-	5.90	47	<0.001*
Loading Zone Size	Max LZ	0.21	799	<0.001*
	Min LZ	0.10	799	0.003*
	No LZ	Base	-	-
Courier Position	Beside	-0.23	799	<0.001*
	Behind	0.12	799	<0.001*
	No Courier	Base	-	-
Accessories	AC	0.05	799	0.035*
	No Acc	Base	-	-
LZ x CP	Max LZ x Beside	0.12	799	0.007*
	Min LZ x Beside	Base	-	-
Summary Statistics				
Adjusted R ²	58%	Observations	864	
-2Log Likelihood	2011.76	Participants	48	
AIC	2015.78	Observations/Participant	18	

*Significant at the 95% confidence level

Regardless of the courier position and accessories, bicyclists tended to have higher speeds with the preferred loading zone and the minimum loading zone conditions than with the no loading zone condition. The random effect was significant (Wald Z=4, p<0.001). This supported the argument that an LMM has better efficiency than a fixed effect linear regression model. Regardless of CVLZ size and courier position, there was a suggestive probability that participants had higher speeds (about 0.8 m/sec) with the presence of accessories (p=0.035)

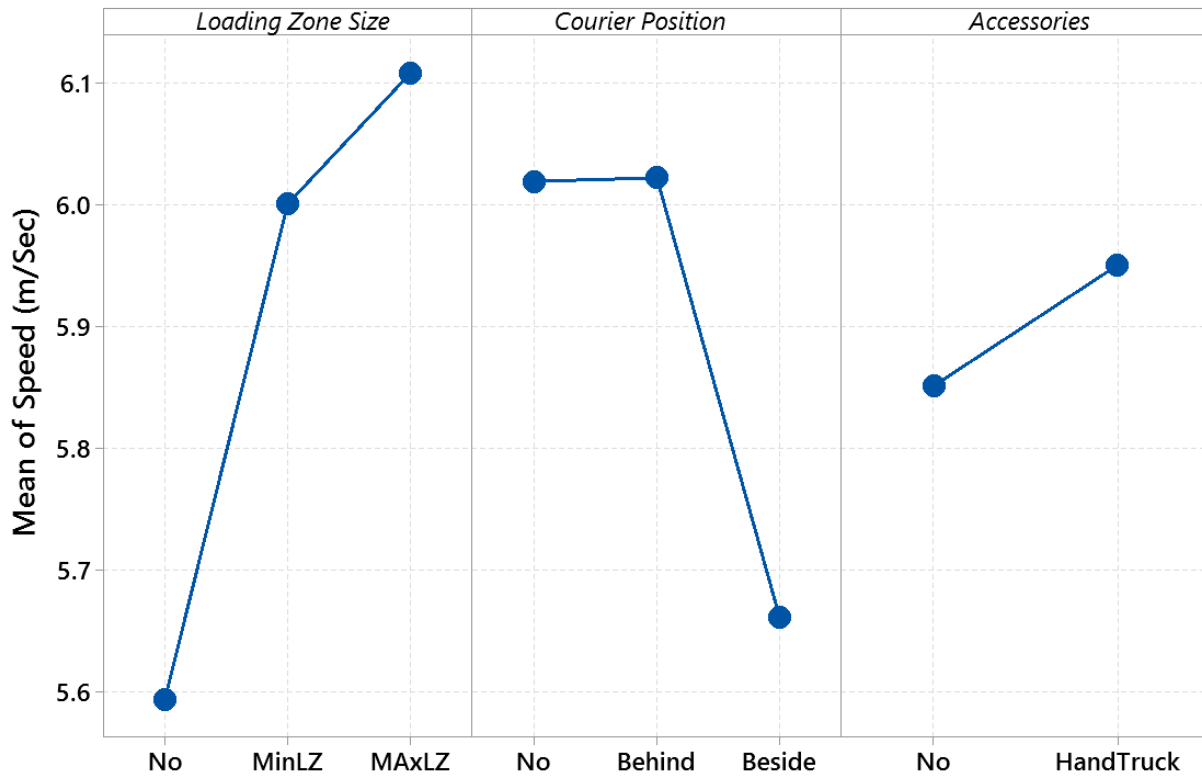

Figure 6.17 Primary effects plot of the selected factors on mean speed

There was only one significant two-way treatment interaction. However, others were considered in the pairwise comparison. Figure 6.18 plots the mean speed at each level of the independent variables. With the accessories variable kept constant, on average the speeds of bicyclists with the minimum loading zone and a courier beside the parked truck were almost a half m/sec slower than their speeds with the preferred loading zone size. This indicated that bicyclists felt more comfortable driving along the preferred loading zone than with a commercial vehicle parked exactly beside the bike lane.

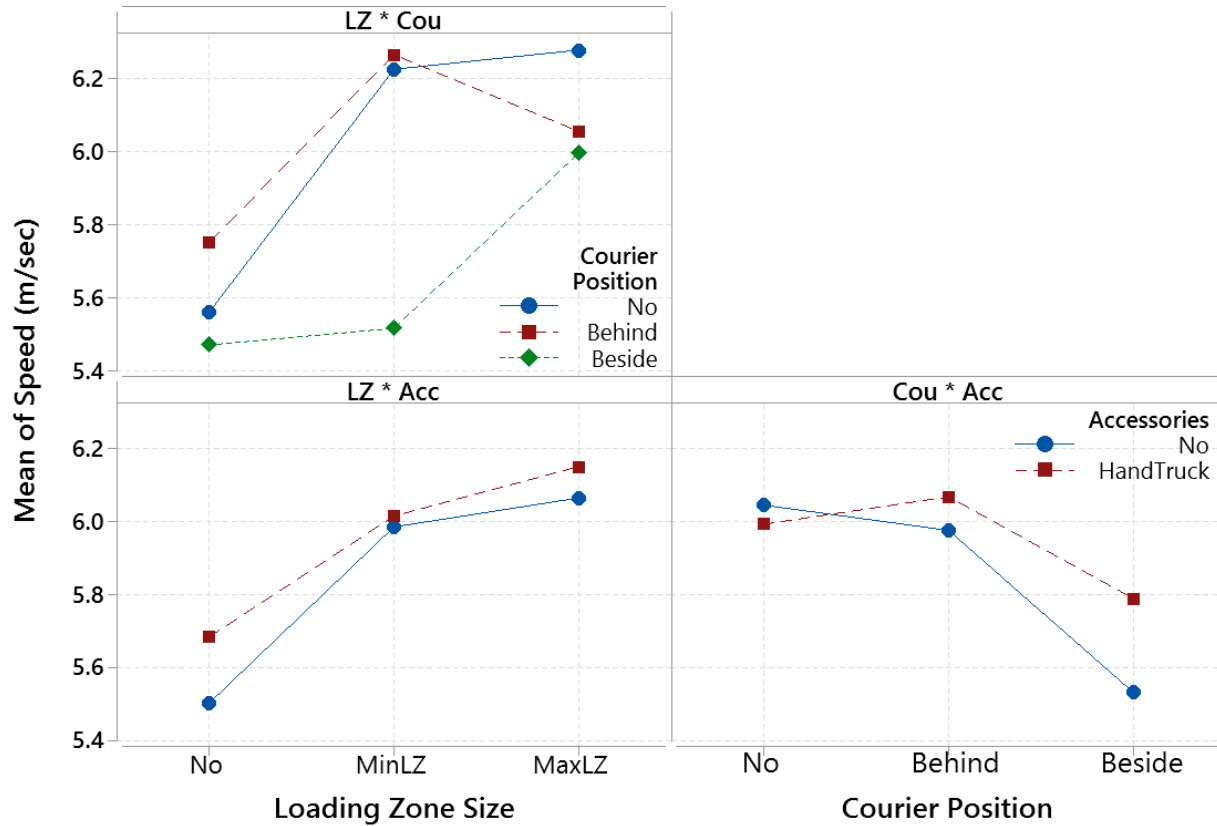

Figure 6.18 Two-way interactions plot of treatment variables on participants' mean speed: a) two-way interactions between loading zone size and courier position, b) two-way interactions between loading zone size and accessories, and c) two-way interactions between courier position and accessories

CHAPTER 7. CONCLUSIONS

This chapter presents the study's conclusions related to the interaction of bikes and delivery trucks in the vicinity of commercial vehicle loading zones in urban areas.

The first section summarizes the approach used to develop the dimensions that were used for the truck envelopes in the simulator. The second section discusses the major findings of the experiment. The subsequent sections discuss the recommendations, the limitations of this study, and opportunities for future research related to bike-delivery truck envelope interaction.

7.1 Data Collection

The research approach initially involved the observation of delivery operations to determine vehicle types, loading actions, door locations, and accessories used. Once common practices had been identified by observing 25 deliveries, then simulated loading activities were measured to quantify different types of loading space requirements around commercial vehicles. This resulted in a measurement of the operating envelope required to reduce conflicts between truck loading and unloading activities and adjacent, bicycle, and motor vehicle activities. These measures resulted in commercial loading zone design recommendations that could be tested in this project's bicycling simulator.

7.2 Bicycle Simulator Findings

The results of this study demonstrated a consistent narrative related to how bicyclists interact with courier's unique actions during the vehicle loading/unloading process in urban areas and to how different levels of space adjacent treatments are effective. Overall, the results showed that courier presence and designated loading zone size have an effect on bicyclists' performance, and this effect varies on the basis of the treatments employed. Also, there may be an increased risk of bicyclist conflicts with other transportation modes in proximity to delivery vehicle activities in urban loading zones, especially when no unique infrastructure treatment is used. The primary findings of this study included the following:

- *Loading zone size and courier position had significant effects on bicyclist speed. A bicyclist passing by a no loading zone (a truck was obstructing the bike lane) or a minimum loading zone (a truck was next to the bike lane without a buffer) had a significantly lower speed than a bicyclist passing a preferred loading zone (a truck had an extra buffer). A smaller loading zone had a decreasing effect on mean speed,*

- with a courier exiting on the driver side of the truck associated with the lowest mean speed.
- *Loading zone size and courier position had significant effects on bicyclist position.* The bicyclists' lateral variability was significantly greater with the no loading zone scenario than with the maximum loading zone size. A courier on the driver's side of the truck had an increasing effect on bicyclists' mean lateral position, with no CVLZ associated with bicyclists' highest divergence from the right edge of the bike lane. Consequently, bicyclists shifted their position toward the left edge of bike lane and even into the adjacent travel lane. Moreover, some bicyclists used the crosswalk to avoid the delivery truck and the travel lane.
 - *Accessories (hand truck and boxes) had a slight effect on bicyclist performance measures such as lateral position and speed.* With other factors kept constant, bicyclists decreased their speed and diverged from the center of the bike lane in the presence of a hand truck. In terms of practice, the difference in performance measures with and without accessories may not be functionally important, although it was statistically significant.
 - *Minimum CVLZ versus maximum CVLZ.* Bicyclists' performance did not differ between the minimum loading zone size and the maximum loading zone size. However, with the presence of a courier on the driver's side of the truck, the minimum CVLZ tended to be the most disruptive for bicyclists because they tended to depart from the bike lane toward the adjacent vehicular travel lane.
 - *Scenarios in which bicyclists used the sidewalk.* When there was no CVLZ, the delivery vehicle parked in the bike lane. When bicyclists approached such a scenario, they had to choose between using the travel lane or the sidewalk. About one third of participants decided to use the sidewalk.

7.3 Recommendations

Depending on the desired bicyclist response for approaching truck loading/unloading activities, the results of the bicycling simulator experiment suggested that different recommended treatments could be distinctly effective. These recommendations could support better roadway and CVLZ design guidelines, which would allow our urban street systems to operate more efficiently, safely, and reliably for all users.

- *To achieve no divergence from the bike lane:* Use the preferred loading zone size (enough buffer for a courier to move around the vehicle).
- *To decrease divergence from the bike lane:* With a minimum loading zone size, provide room for the courier behind the truck.
- *To reduce bicycle speeds:* Use a minimum loading zone size with a courier on the side or no CVLZ regardless of the courier's location.
- *To improve bicyclist performance measures:* Provide an extra buffer in the CVLZ for the courier.
- *To allow bicycles to use the sidewalk:* In states where bicyclists are allowed to use the sidewalk, access for the sidewalk should be designed to accommodate bicyclists when a delivery truck is anticipated to obstruct the bike lane because of loading/unloading activities. The downside of this recommendation is the potential risk from the interaction between bicyclists and pedestrians.
- *To prevent the interaction between bicyclists and traffic in the travel lane:* Place barriers or buffer zones on the left side of the bike lane in zones where commercial vehicles exist.
- In situations where only a minimum loading zone can be designed because of space restrictions, couriers should minimize their time in the bike lane to move along the vehicle and exit on the passenger side instead of the driver side (e.g., similar to UPS truck design).

7.4 Limitations

The following are the primary limitations of this project:

- A basic limitation of within-subject design is fatigue and carryover effects, which can cause participants' performance to degrade over the course of the experiment as they become tired or bored. The order of the scenarios was partially randomized, and the duration of the test drives were relatively brief to minimize these effects.
- The visual display of the bicycle simulator used in this study did not provide a peripheral field of view for participants. While peripheral vision was limited and the bicyclist could not view vehicles before they entered the loading zone, a surrounding sound system allowed bicyclists to hear traffic sounds.

7.5 Future Work

Additional research is needed to continue to explore the critical safety issue related to the interactions between delivery vehicles and other users in an urban environment, in particular, cases in which CVLZ activity disrupts the activity of bicyclists. The following are potential research threads that would augment this study and further expand this topic:

- This research studied loading zone size, courier position, and accessories as the independent variables for bike-delivery truck interactions. Many other variables could also be considered. For example, heavier traffic volumes, pedestrians on the sidewalk, and leading bicyclists could potentially provide different interaction behaviors for bicyclists. Additionally, different forms of bike lanes, such as buffered bike lanes or contra-flow bike lanes, could be modeled in a virtual environment to quantitatively compare the effectiveness of different design practices.
- Incorporate a wider range of truck sizes and loading zone sizes.
- Use an instrumented bicycle experiment in an urban area to help validate the results of this study.

REFERENCES

- AASHTO (2011), American Association of State Highway and Transportation Officials The Green Book, A Policy on Geometric Design of Highways and Streets, 6th Edition.
- Abadi, M. G., Fleskes, K., Jashami, H., & Hurwitz, D. S. (2018). Bicyclist's Perceived Level of Comfort Level Traveling Near Urban Truck Loading Zones. Transportation Research Board 97th Annual Meeting, Washington DC, United States. 18-02144.
- Barlow, Z., Jashami, H., Sova, A., Hurwitz, D. S., & Olsen, M. J. (2019). Policy processes and recommendations for Unmanned Aerial System operations near roadways based on visual attention of drivers. Transportation Research Part C: Emerging Technologies, 108, 207-222.
- City Lab (2012), U.S. Urban Population Is Up ... But What Does 'Urban' Really Mean?, <https://www.citylab.com/equity/2012/03/us-urban-population-what-does-urban-really-mean/1589/>, Accessed on: May 2, 2018.
- City of Portland (2008), Office of Transportation. *Designing for Truck Movements and Other Large Vehicles in Portland*. City of Portland, Oregon. <https://www.portlandoregon.gov/transportation/article/357099>.
- City of Seattle (2016). *City of Seattle Grant Closeout Report: Seattle Commercial Vehicle Pricing Pilot Project*. Seattle: s.n., 2016. Project No: VPPP-1140(052), Agreement No: LA 7755, 08/2012 – 01/2016.
- Cnaan, A., Laird, N.M., Slasor, P., (1997). Using the general linear mixed model to analyse unbalanced repeated measures and longitudinal data. Stat. Med. 16, 2349–2380.
- District Department of Transportation. (2014). Planning, Policy & Sustainable Transportation, The District of Columbia's Multimodal Long-Range Transportation Plan, Parking and Curbside Management Element. Washington, D.C.
- FHWA, 2014
- FHWA (2016) Federal Highway Administration, Traffic Monitoring Guide, (Figure 1-1) https://www.fhwa.dot.gov/policyinformation/tmguidetmg_fhwa_pl_17_003.pdf
- Fisher, D.L., Rizzo, M., Caird, J. and Lee, J.D. eds., (2011). Handbook of driving simulation for engineering, medicine, and psychology. CRC Press.
- Goodchild, A., Ivanov, B., McCormack, E., Moudon, A., Scully, J., Leon, J.M. and Giron Valderrama, G. (2018). Are Cities' Delivery Spaces in the Right Places? Mapping Truck Load/Unload Locations. City Logistics 2: Modeling and Planning Initiatives, pp.351-368. 2018.

- Health and Safety Executive (2019). Delivering Safely, <http://www.hse.gov.uk/workplacetransport/information/cooperation.htm>, Accessed on: March 12, 2019.
- Hurwitz, D. S., Horne, D., Jashami, H., & Abadi, M. G. (2019). *Bicycling Simulator Calibration: Speed and Steering Latency*. Pacific Northwest Transportation Consortium (PacTrans), Seattle, WA.
- Hurwitz, D., Jashami, H., Buker, K., Monsere, C., Kothuri, S., & Kading, A. (2018). *Improved Safety and Efficiency of Protected/Permitted Right-Turns in Oregon* (No. FHWA-OR-RD-18-14).
- Jashami, H., Hurwitz, D. S., Monsere, C., & Kothuri, S. (2019). *Evaluation of Driver Comprehension and Visual Attention of the Flashing Yellow Arrow Display for Permissive Right Turns*. Transportation Research Record.
- Maruyama, N., (2008). *Generalized Linear Models Using Trajectories Estimated from a Linear Mixed Model*. Kitasato University.
- Municibid, 2018
- MUTCD (2012) Federal Highway Administration, *Manual on Uniform Traffic Control Devices for Streets and Highways*.
- NACTO, (2019) National Complete Street Coalition, <https://smartgrowthamerica.org/program/national-complete-streets-coalition/>, Accessed on: March 12, 2019.
- NACTO (2016a) *Global Street Design Guide*, Global Designing Cities Initiative, NACTO, New York, Island Press
- NACTO (2016b) *Transit Street Design Guide*, New York Island Press.
- Ogden, K. W. (1991). Truck movement and access in urban areas. *Journal of Transportation Engineering*, 117(1), 71-90.
- Owens, D. A., and Tyrrell, R. A. (1999). Effects of luminance, blur, and age on nighttime visual guidance: A test of the selective degradation hypothesis. *Journal of Experimental Psychology: Applied*, 5(2), 115-128.
- Pivo, G., Carlson, D., Kitchen, M., & Billen, D. (2002). *Leaning from Truckers: Truck Driver's Views on the Planning and Design of Urban and Suburban Center*. *Journal of Architectural and Planning Research*, 19(1), 12-29.
- SCTL 2018



























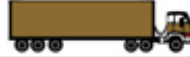





- SCTL, Supply Chain, Transportation and Logistics Center The Final 50 Feet, Urban Goods Delivery System, (2019) Final Report, University of Washington, https://depts.washington.edu/sctlctr/sites/default/files/SCTL_Final_50_full_report.pdf.
- SDOT (2015a), Seattle Department of Transportation) Can I Park Here? <https://www.seattle.gov/Documents/Departments/SDOT/ParkingProgram/CanIParkHereBrochure.pdf>, Accessed on: March 19, 2019.
- SDOT (2015b) Seattle Department of Transportation , Move Seattle - 10 -Year Strategic Vision for Transportation. Seattle.
- SDOT (2016). Seattle Department of Transportation. (2016) City of Seattle Freight Master Plan.
- SDOT (2018) —. Curb Colors. Seattle Department of Transportation. [Online] [Cited: April 01, 2018.] <https://www.seattle.gov/transportation/projects-and-programs/programs/parking-program/parking-regulations/curb-colors>.
- SFMTA (2019) San Francisco Municipal Transportation Agency. Color Curbs, <https://www.sfmta.com/getting-around/drive-park/color-curbs>. Accessed on: May 2, 2019.
- Smart Growth America (2019) , What is Smart Growth, <https://smartgrowthamerica.org/>, Accessed on: March 12, 2019.
- US Census Bureau News, (2019), Quarterly Retail E-Commerce Sales 4th quarter 2018, https://www.census.gov/retail/mrts/www/data/pdf/ec_current.pdf March 13, Accessed on: March 19, 2019.
- WSDOT (2017). Washington State Department of Transportation Design Manual. Engineering and Regional Operations.
- Wygonik, E., A. Bassok, A. Goodchild, E. McCormack, and D. Carlson, (2015) Smart growth and goods movement: emerging research agendas. *Journal of Urbanism: International Research on Placemaking and Urban Sustainability*, 8(2), pp.115-132.

APPENDIX 1. FIELD OBSERVATIONS – EXAMPLE DATA COLLECTION FORM

<u>Delivery Location, Date, Time</u>	<u>Commercial Vehicle Characteristics</u>	<u>Exiting/Entering Vehicle Behavior</u>	<u>Accessory Used & Accessory Path</u>	<u>Courier Path to Access Cargo – Movements Described Around Commercial Vehicle</u>	<u>Delivery Characteristics & Goods Described</u>	<u>Courier Behavior in Response to Built Environment</u>
<i>Location</i>	<i>Delivery Company</i>	<i>Vehicle Exit/Enter Points</i>	<i>Accessory Used</i>		<i>Number of Courier</i>	<i>Description of Unique Movements Observed</i>
<i>Date</i>	<i>Vehicle Classification</i>		<i>Accessory Path</i>		<i>Goods Described</i>	
<i>Time</i>	<i>Driver & Passenger Entry/Exit Door Type</i>					
	<i>Cargo Compartment Door Location</i>					
	<i>Cargo Door Type</i>					

APPENDIX 2. VEHICLE CLASSIFICATION DESCRIPTION

These are the USDOT recommended classifications from the 2014 Traffic Monitoring Guide on the Policy and Governmental Affairs - Office of Highway Policy Information website.

Class 1 Motorcycles		Class 7 Four or more axle, single unit		
Class 2 Passenger cars		Class 8 Four or less axle, single trailer		
				
				
				
Class 3 Four tire, single unit		Class 9 5-Axle tractor semitrailer		
				
				
Class 4 Buses		Class 10 Six or more axle, single trailer		
				
			Class 11 Five or less axle, multi trailer	
Class 5 Two axle, six tire, single unit		Class 12 Six axle, multi-trailer		
				
			Class 13 Seven or more axle, multi-trailer	
Class 6 Three axle, single unit				
				
				

Source (3)

“**Motorcycles** – All two or three-wheeled motorized vehicles. Typical vehicles in this category have saddle type seats and are steered by handlebars rather than steering wheels. This

category includes motorcycles, motor scooters, mopeds, motor-powered bicycles, and three-wheel motorcycles.

Passenger Cars – All sedans, coupes, and station wagons manufactured primarily for the purpose of carrying passengers and including those passenger cars pulling recreational or other light trailers.

Other Two-Axle, Four-Tire Single Unit Vehicles – All two-axle, four-tire, vehicles, other than passenger cars. Included in this classification are pickups, panels, vans, and other vehicles such as campers, motor homes, ambulances, hearses, carryalls, and minibuses. Other two-axle, four-tire single-unit vehicles pulling recreational or other light trailers are included in this classification. Because automatic vehicle classifiers have difficulty distinguishing class 3 from class 2, these two classes may be combined into class 2.

Buses – All vehicles manufactured as traditional passenger-carrying buses with two axles and six tires or three or more axles. This category includes only traditional buses (including school buses) functioning as passenger-carrying vehicles. Modified buses should be considered to be a truck and should be appropriately classified.

In reporting information on trucks, the following criteria should be used:

Truck tractor units traveling without a trailer will be considered single-unit trucks; A truck tractor unit pulling other such units in a saddle mount configuration will be considered one single-unit truck and will be defined only by the axles on the pulling unit; Vehicles are defined by the number of axles in contact with the road. Therefore, floating axles are counted only when in the down position; and The term "trailer" includes both semi- and full trailers.

Two-Axle, Six-Tire, Single-Unit Trucks – All vehicles on a single frame including trucks, camping and recreational vehicles, motor homes, etc., with two axles and dual rear wheels.

Three-Axle Single-Unit Trucks – All vehicles on a single frame including trucks, camping and recreational vehicles, motor homes, etc., with three axles.

Four or More Axle Single-Unit Trucks – All trucks on a single frame with four or more axles

Four or Fewer Axle Single-Trailer Trucks – All vehicles with four or fewer axles consisting of two units, one of which is a tractor or straight truck power unit.

Five-Axle Single-Trailer Trucks – All five-axle vehicles consisting of two units, one of which is a tractor or straight truck power unit.

Six or More Axle Single-Trailer Trucks – All vehicles with six or more axles consisting of two units, one of which is a tractor or straight truck power unit.

Five or Fewer Axle Multi-Trailer Trucks – All vehicles with five or fewer axles consisting of three or more units, one of which is a tractor or straight truck power unit.

Six-Axle Multi-Trailer Trucks – All six-axle vehicles consisting of three or more units, one of which is a tractor or straight truck power unit

Seven or More Axle Multi-Trailer Trucks – All vehicles with seven or more axles consisting of three or more units, one of which is a tractor or straight truck power unit” (3).

APPENDIX 3. IMAGES OF DELIVERY ACCESSORIES



Ramp that may be used to facilitate deliveries (Discount Ramps website)



Cones may be used to facilitate deliveries



Hand truck may be used to facilitate deliveries (Northern Tool + Equipment website)





Two-way convertible hand truck (Sears website)



Platform truck may be used to facilitate deliveries (SP Richards Company website)

APPENDIX 4. SIMULATION DATA FORM

<u>Delivery Location, Date, Time</u>	<u>Commercial Vehicle Characteristics</u>	<u>Exiting/Entering Vehicle Behavior</u>	<u>Accessory Used & Accessory Path</u>	<u>Courier Path to Access Cargo – Movements Described Around Commercial Vehicle</u>	<u>Delivery Characteristics & Goods Described</u>	<u>Courier Behavior in Response to Built Environment</u>
Location	Delivery Company	Vehicle Exit/Enter Points	Accessory Used		Number of Courier	Description of Unique Movements Observed
Date	Vehicle Classification		Accessory Path		Goods Described	
Time	Driver & Passenger Entry/Exit Door Type					
	Cargo Compartment Door Location					
	Cargo Door Type					

Vehicle Type -

Company Name - Charlie's Produce

SPECIFICATIONS

1. Closed Footprint

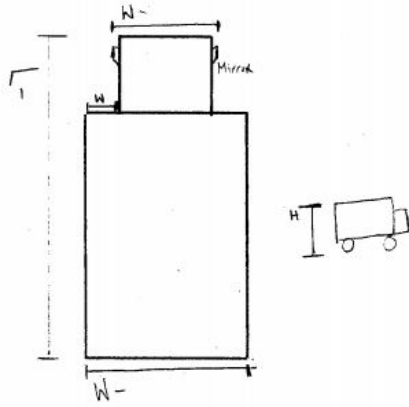

2. Open Footprint- Please hand draw if needed

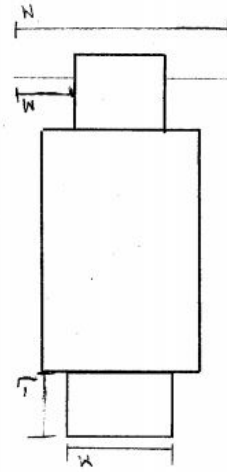

Vehicle Type –

Company Name – Charlie's Produce

3a. ACTIVE FOOTPRINT –

Driver/Courier Movement



3b. ACTIVE FOOTPRINT –

Accessory Movements

Accessory Type:

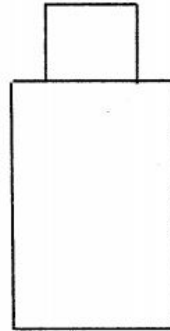

Vehicle Type – Package Car

Company Name – UPS

SPECIFICATIONS

1. Closed Footprint

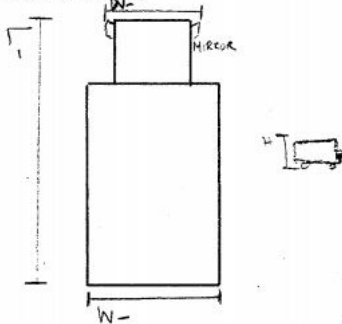

2. Open Footprint - Please Hand Draw IF Needed



3a. ACTIVE FOOTPRINT – Driver/Courier Movement

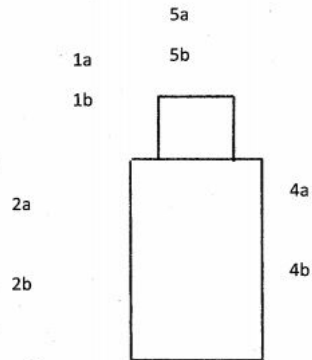

Key:
 A/C – Space needed in inches
 B/D – Space desired in inches
 Round to the nearest inch.

3b. ACTIVE FOOTPRINT - Accessory Movements

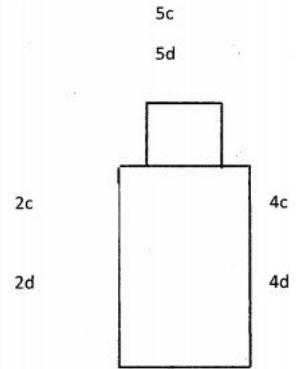

Accessory: Hand Truck

3c

3d

Accessory:

6 a

6 b

Accessory:

7 a

7 b

APPENDIX 5. DRIVER INTERVIEW FORM

Name

Company Name

Vehicle Type

Could I please audio record this interview? Please answer the following questions with the following scenario in mind: You have just parked on an urban street and you must load/unload goods.

1. What causes the most problems while loading/unloading? Why?
2. Is there enough space to comfortably get in and out of your vehicle?
3. Is there enough space to maneuver and use this accessory?
4. Mark where you *usually* load/unload goods. Why?



5. Mark where you *prefer* to load/unload goods. Why?



6. What are the most common accessories used with this vehicle type? Why?

7. What infrastructure helps you load/unload? Why? (Infrastructure - the basic, underlying framework or features of a system or organization (1) [e.g., curb cuts, clear pavement markings, curb ramps, visible curb paint, etc.]

8. What would you change about the design of commercial vehicle load zones? Why?