

Implementing Temporary LED Construction Lighting

Christopher Mak

A thesis

submitted in partial fulfillment of the
requirements for the degree of

Master of Science in Construction Management

University of Washington

2017

Committee:

Ken-Yu Lin

Edmund Seto

Hyun Woo Lee

Program Authorized to Offer Degree:

Construction Management

© Copyright 2017
Christopher Mak

University of Washington

Abstract

Implementing Temporary LED Construction Lighting

Christopher Mak

Chair of the Supervisory Committee:
Professor Ken-Yu Lin
Department of Construction Management

LED lighting technology is continuing to grow and change every 6 months. While other manufacturers and consumers are finding creative ways to implement them in their products and everyday life, the construction industry has yet to widely adopt and embrace the technology as a temporary lighting source on their projects. Although initially expensive when compared with other construction lighting systems, the cost of LEDs is decreasing while improvements in LED luminaire efficiency increases. Furthermore, the energy, maintenance, and safety benefits of a temporary LED lighting system may be an overlooked consideration for general contractors and subcontractors as (1) the information has yet to be thoroughly studied and targeted at the construction industry, (2) initial costs of entry may be prohibitive when compared with older sources of luminance, and/or (3) general contractors and subcontractors may be satisfied with the status quo.

Unfortunately, improvements in temporary lighting technology for building construction have been neglected academically and within the construction industry. However, the objective of this thesis is to serve as a guide by looking at the safety, energy and maintenance benefits of LED construction lighting, through literature review, lessons learned from two case studies, and independent investigation by the author.

Literature review will provide a background on how LEDs work, what traditional lighting is, who regulates quality of luminance on jobsites, and how lighting affects the safety and health of workers.

Next, the thesis incorporates two case studies, both of which were conducted at the behest of the University of Washington's (UW) Capital Planning and Development office (CPD). The first case study was generated in 2014. The study, written by UW Construction Management graduate student Yi Jie Huang, focused on the temporary construction lighting at the UW's Bothell Phase 3 Project. The report looks at: (1) the system's installation method; (2) labor, material, and energy cost; (3) stakeholder interviews; and (4) a qualitative survey of the workers.

The second case study, written by UW Construction Management and Occupational Safety and Health graduate student Christopher Mak, further updates the UW's narrative on LED lighting, and illustrates the history and reasoning behind implementing low-voltage LEDs on their projects. The report homes in on the LED utilization at the UW's Animal Research and Care Facility (ARCF) construction site. Like the report on the Bothell Phase 3 project, the second case study looks at: (1) installation method; (2) labor, material, and energy costs; and (3) conducts a qualitative survey of workers. Finally, the author ran three quantitative studies looking at light levels, energy use, and lighting quality. Data collected is displayed and interpreted within.

The final issue the author looks at is the possibility of glare, which arose during qualitative data analysis of both case studies' responses. Glare emanating from white LEDs is a potential safety hazard and an environmental quality problem. Moreover, defining hazardous amounts of glare can be subjective and hard to quantify. The author implements a glare quantifying methodology using HDR photography, and uses the technique to gauge the quality of light emanating from ARCF's new LEDs.

The thesis concludes with lessons learned regarding how users can better implement temporary LED lighting to their full benefit from the trials and tribulations experienced by the UW, observations made by the author, and from the Seattle City Light inspection and energy incentive process.

Table of Contents

Abstract	2
Acknowledgements	11
Chapter 1: Introduction	12
University of Washington’s LED Temporary Lighting Development	13
Defining Light-emitting Diodes	14
UW’s Temporary Lighting Investment	16
FM2 (10W/1000 lumens)	16
FM10 (30W/3000 lumens)	17
FPS450DT (450Watts)	17
LED Testing Standards and Ratings: L70, LM-79, LM-80, TM-21	18
What is Traditional Temporary Construction Lighting?	20
Florescent Lamps and CFLs	20
Incandescent Lamps	21
High Intensity Discharge (HID)	22
Chapter 1 Summary	23
Chapter 2: Safety Regulations and Recommendations	24
Workplace Illuminance Regulations and Recommendations	25
Challenging Traditional Construction Lighting Quality	29
Human Performance in Insufficient Lighting	30
Visual Performance: Contrast, Color, Illuminance and Glare	32
How LEDs Can Potentially Increase Safety on Worksites	34
Nighttime Highway Construction.....	36
Metal Halide Near-Miss	37
Chapter 2 Summary	38
Chapter 3: UW Study: Bothell Phase 3	40
2012 UW Bothell Phase 3	41
Installation Method at UWB P3	41
Estimated Costs and Energy Use at UWB P3	43
UWB P3 Stakeholder Interviews	45
UWB P3 Worker Survey	47

UW LED History Continued	48
Chapter 3 Summary	51
Chapter 4: Animal Research and Care Facility	52
Case Study 2: Animal Research and Care Facility Site	53
ARCF Contract Provisions and General Requirements	53
Installation of Lights at ARCF	54
Installation Time Frame	59
Clear-Vu’s 2015 Estimated Costs and Savings	59
Cochran’s 2016 Traditional Lighting Cost Estimate	62
Cochran’s LED Lighting Cost	62
Energy Use Costs	63
Cost Differences Between Traditional Lighting	65
Other Temporary Lighting Used Onsite	66
Survey of Trades	68
Other Qualitative Findings	76
Combined Surveys	73
Chapter 4 Summary	82
Chapter 5: ARCF Lighting Survey	84
Methodology	85
Methodology Limitations	89
Light Meter Findings and Observations	90
Other Observations	95
Chapter 5 Summary	96
Chapter 6: Glare Analysis	97
Scope of the Issue	98
Methodology	100
Tools Used for Glare Analysis	101
HDR Photography	101
Camera Calibration	102
Aperture	102
Shutter Speed	102

ISO	102
Checking Glare Through EvalGlare	107
Daylight Glare Probability (DGP)	107
Daylight Glare Index (DGI)	107
Unified Glare Rating (UGR)	108
Visual Comfort Probability (VCP)	108
CIE Glare Index (CGI)	108
CIE Veiling Luminance (Lveil)	109
Glare Analysis of Clear-Vu LEDs	112
Chapter 6 Summary	119
Chapter 7: Seattle City Light Energy Incentive	120
Seattle City Light Inspection and Rebate Discussions	121
Seattle City Light Energy Rebate	122
Calculating SCL’s Incentive for Permanent Fixtures	126
Chapter 7 Summary	127
Chapter 8: Conclusion	129
Design and Safety Benefits	130
Previous UW Study: UW Bothell Phase 3	130
Case Study: ARCF	131
Worker Survey	131
Glare Analysis	132
Seattle City Light Review	132
Lessons Learned	133
References	136
Appendix	141
Survey Questions	141

List of Figures

Figure 1: Light-Emitting Diode Phosphor Diagram	15
Figure 2: FM2 LED Module	16
Figure 3: FM10 LED Module	17
Figure 4: FPS450DT Power Supply/Ballast	18
Figure 5: Wooblelight Models	23
Figure 6: Illuminance Levels and Rates of Injuries	31
Figure 7: Effects of Light on Human Performance	32
Figure 8: Bravern Wobble Light Fire	37
Figure 9: Bravern Wobble Light Fire	38
Figure 10: Preconstruction Planning of LED Inserts	42
Figure 11: LED Wire Inserts.....	42
Figure 12: UWB P3 Cost Estimate Graph	45
Figure 13: 24-Month NanoES LED Cost Estimate.....	50
Figure 14: 12-Month Estimated Cost at Life Science Building.....	50
Figure 15: Photometric Plans of ARCF LEDs.....	55
Figure 16: Reflected Ceiling Plan for Temporary Lighting.....	56
Figure 17: FM2 and Twist-Lock Connector at ARCF Stairwell	57
Figure 18: Permanent FM10 in Interstitial Area.....	58
Figure 19: FM10 and Twist-Lock Connector in Interstitial Area.....	58
Figure 20: Installed Energy Logger at ARCF.....	63
Figure 21: ARCF Cost Estimate Comparison.....	65
Figure 22: Comparable System Lighting Cost Estimates.....	66
Figure 23: RAB FXLED300T LED.....	67
Figure 24: Tiger 400 HID MH.....	68
Figure 25: B02 Quadrant B.....	86
Figure 26: B02 Quadrant D.....	87
Figure 27: B02 Partial Interstitial Area Over Quadrant B	88
Figure 28: Light Meter Set Up.....	88
Figure 29: Meter Reading Near Chop Saw Work Station	89
Figure 30: Lights High Above Framing and Shadows Cast by Tool Box	91

Figure 31: Foot-candle Measurement Notes From Area in Figure 20.....	92
Figure 32: Corridor D: FM2 Blocked by Steel Framing.....	93
Figure 33: FM2 in Interstitial B02 Blocked by Insulation.....	94
Figure 34: FM10 Tipped Over.....	94
Figure 35: LED Layout.....	95
Figure 36: Cochran Photometrics	95
Figure 37: Notes and Observations.....	95
Figure 38: Luminaire Color Spectrum.....	99
Figure 39: Dynamic Range Comparison.....	101
Figure 40: Varying Exposures of a Scene.....	103
Figure 41: Photosphere GUI Interface.....	104
Figure 42: HDR Creation Options	105
Figure 43: Uncalibrated False Color Rendering.....	105
Figure 44: Spot Luminance Calibration.....	106
Figure 45: Illustration of Veiling Luminance Within the Eye.....	109
Figure 46: Command-line Entry Example.....	110
Figure 47: HDR Scope GUI.....	111
Figure 48: Sample Image Run Through Evalglare	112
Figure 49: HDR Photograph 1	113
Figure 50: HDR Photograph 2	114
Figure 51: HDR Photograph 3	115
Figure 52: Glare Analysis of Photograph 1	116
Figure 53: Glare Analysis of Photograph 2	117
Figure 54: Glare Analysis of Photograph 3	118

List of Tables

Table 1: FM2 Specifications.....	16
Table 2: FM10 Specifications.....	17
Table 3: FPS450DT Specifications.....	18
Table 4: OSHA Minimum Illumination Standards.....	26
Table 5: WAC Minimum Acceptable Average Lighting Level in an Area.....	27

Table 6: ANSI/IES RP7-1979 Recommendation Lighting Values.....	28
Table 7: Construction and Manufacturing Foot-Candle Recommendations	29
Table 8: Work Productivity Increases by Activity	30
Table 9: Cost and Lighting Schedule Comparisons.....	43
Table 10: Nelson Electric Cost Estimate	44
Table 11: Average Rating of Positive Lighting Attributes	47
Table 12: Combined Average Rating of Negative Attributes.....	48
Table 13: Material Schedule and Labor Hours at NanoES.....	49
Table 14: Weekly Tracking Report of Temporary Light Installation.....	59
Table 15: 2015 ARCF Clear-Vu Estimated Energy and Materials Cost	60
Table 16: Clear-Vu Estimated Energy, Materials & Projected Labor Savings Comparison.....	61
Table 17: Clear-Vu Temporary Lighting Cost/Benefit Breakdown	61
Table 18: Weekly Tracking Report Budget Analysis	63
Table 19: Measured Energy Use.....	64
Table 20: Estimated Energy Cost	64
Table 21: Cochran Cost Comparison.....	65
Table 22: Comparable System Lighting Estimates.....	66
Table 23: Average Rating of Positive Lighting Attributes	69
Table 24: Average Rating of Negative Attributes	69
Table 25: ARCF Trades with Color Legend.....	71
Table 26: LED Provides More Lighting Than TRAD	71
Table 27: LED Provides More Consistent and Well Distributed Lighting Than TRAD.....	72
Table 28: I Feel More Productive with LED Than with TRAD.....	72
Table 29: LED Is More Visually Comfortable Than TRAD	73
Table 30: LED Lighting Made My Work More Operationally Safer.....	73
<i>Table 31: LEDs Distracted Me from Working Properly More Than TRAD.....</i>	<i>74</i>
Table 32: LED Disrupted My Work More Than TRAD	74
Table 33: LED Required More Coordination Efforts Than TRAD.....	75
Table 34: Combined Average Rating of Positive Lighting Attributes	77
Table 35: Combined Average Rating of Negative Attributes.....	77
Table 36: Combined Survey Trades with Color Legend	78

Table 37: LED Provides More Lighting Than TRAD	78
Table 38: LED Provides More Consistent and Well Distributed Lighting Than TRAD.....	79
Table 39: I Feel More Productive with LED Than with TRAD.....	79
Table 40: LED Is More Visually Comfortable Than TRAD	80
Table 41: LED Lighting Made My Work More Operationally Safer.....	80
Table 42: LEDs Distracted Me from Working Properly More Than TRAD.....	81
Table 43: Table 43: LED Disrupted My Work More Than TRAD	81
Table 44: LED Required More Coordination Efforts Than TRAD.....	82
Table 45: Foot-candle Lighting Measurements	90
Table 46: Foot-Candle Range	90
Table 47: Jakubiec and Reinhart’s Glare Indices	110
Table 48: Discomfort Glare Indices for Example Analysis.....	112
Table 49: Photograph 1 Measured Variables.....	113
Table 50: Photograph 2 Measured Variables.....	114
Table 51: Photograph 3 Measured Variables.....	115
Table 52: Glare Analysis Results for Photograph 1.....	116
Table 53: Glare Analysis Results of Photograph 2.....	117
Table 54: Glare Analysis Results of Photograph 3.....	118
Table 55: Updated LED Material Cost Calculations	123
Table 56: SCL Incentive: Updated Temporary Lighting Schedule and Energy Use.....	125
Table 57: SCL Incentive: Updated Permanent Lighting Schedule and Energy Use	127

Acknowledgements

I would like to take some time to express my gratitude to all the individuals who helped and supported me throughout this thesis's journey. First, a big thank you to my thesis committee, Dr. Ken-Yu Lin, Dr. Edmund Seto, and Dr. Chris Lee for helping me navigate the world of academia, and for providing valuable encouragement, insight, and feedback. I would especially like to recognize Dr. Lin for her personal candor and persistent effort in the cultivation of my intellectual wealth. Dr. Lin also had a hand in tempering my self-confidence--I will never forget the experience of sharing my research at the 2017 CERC conference.

I am also very appreciative of my time spent working with the University of Washington's Capital Planning and Development Office. Special thanks are due to the CPD's ARCF project management team, Jeff Angeley, Steven Babinec, and Laura Saum for all their help and candid wisdom that one can only achieve from years of construction experience. Notably, Jeff Angeley was an indispensable mentor throughout this endeavor, providing me with equal access to CPD resources, and continuing to support me throughout the research and writing process.

Finally, I am incredibly grateful to have such a wonderful family—Mom, Dad, Eric Mak, and Hailey--without which I would have withered long ago. To my parents, everything you said turned out to be true. To my brother, thank you for taking me out to dinner whenever I asked. And to Hailey, you are the best partner under the sun and moon.

Chapter 1.

Introduction

University of Washington's LED Temporary Lighting Development

In 2011, the UW's Capital Planning and Development Office (CPD) undertook the task of improving safety on their construction sites, and took aim at an often-ignored aspect of construction—temporary work lighting. The CPD challenged the ingrained notion that traditional lighting was an adequate source for construction site illumination and that minimum lighting requirements were tolerable for workers on their jobsites. The CPD put forth the initiative to use a new, forward-thinking lighting system.

During their selection process, the CPD outlined a list of criteria of what they were looking for in a temporary construction lighting system: (1) the system must meet or exceed OSHA and State foot-candle requirements; (2) the lights need be portable, easy to install, remove, and move from project to project; (3) it should be low-voltage for ease of installation, and for the reduction of electrocution and shock hazards, especially around wet areas; (4) the system needs to save on energy and reduce maintenance-related wasted; and (5) it should be easy to maintain and require little material support. The decision to invest in an LED construction lighting system was an intuitive, high-tech solution that could meet the lighting challenges of a modern construction site, while increasing safety, productivity, and sustainability.

The CPD's working relationship with the general contractor Skanska facilitated the trial and eventual acquisition of a LED system. Harvard University's Fogg Museum had worked with Skanska on their renovation project, which implemented construction lighting manufactured by an east coast company, Clear-Vu. The Skanska led project eventually won a LEED Innovation Design credit for the use of LEDs as temporary work lights. In 2011, the CPD contacted one of the site Project Managers, Paul Davey, and asked him to send over a Clear-Vu LED pilot lighting kit for testing.

The CPD first installed the pilot kit on the UW Medical Tower renovation, and then moved the kit over to the Odegaard Undergraduate Library after the Medical Tower project had been completed. In 2012, work began on the UW Bothell Phase 3 (UWB P3) project. This construction project marked the first large scale use of LEDs by UW, and became the subject of

a case study, written by UW graduate student Yi Jie Huang. Her case study is summarized within Chapter 3 of this thesis. Although the CPD was interested in the costs and performance related to the Clear-Vu lights, the commissioned case study was the UW's first academic report on the new temporary system. In 2016, the CPD commissioned a second case study on their LED construction lights from the author. The new report was an updated narrative and study on the implementation of the LED lights at the UW's Animal Research and Care Facility construction site. The resulting case study became the centerpiece for this thesis.

As of 2017, eight other campus projects have used or are projected to use LED luminaires as the main source of construction lighting. More information regarding those projects can be found within further chapters.

Defining Light-emitting Diodes

What are light-emitting diodes (LEDs)? Primarily, a diode's purpose is to move an electrical current forward through a semiconducting material, such as aluminum gallium indium phosphide (AlGaInP), or indium gallium nitride (InGaN) (Lenk and Lenk. 2011, Khan, et al. 2014). All diodes emit some quantity of light while functioning; however, LEDs are diodes specifically designed to take advantage of this property. By running more current through the semiconductors, photons are emitted in a process known as electroluminescence (Khan, et al. 2014).

The quality and color of light depends on the semiconducting material and the amount of current moving through the diode. In the case of the typical, commercially available white LED, indium gallium nitride (InGaN) semiconductors are used to generate an intense blue light. However, to shift the blue spectrum to a perceived "white" color, a complex, polycrystalline inorganic coating is applied to an LED to filter out and reemit certain color frequencies (Lenk and Lenk. 2011). These coatings, known as phosphors, are usually applied on top of, or mixed into the protective silicone encapsulate, which can be seen in figure 1. Unfortunately, the phosphor coating slowly degrades over time as it is subjected to heat over its lifespan; and although it is not entirely known why LEDs lose efficiency, exposure to heat is the primary reason LEDs slowly drop in light output (Lenk and Lenk. 2011). So, it is in the LED designers and manufacturers best interest

to keep chip temperatures low to reduce the rate of degradation. However, by running more current and heat through a diode, manufacturers can overclock their LEDs, essentially pushing more luminance at the cost of longevity.

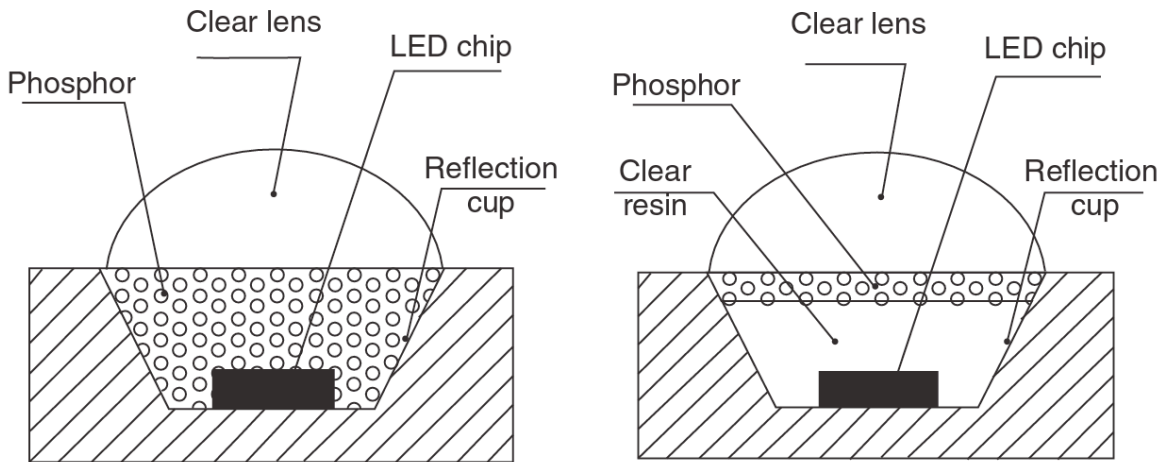

Figure 1: Light-Emitting Diode Phosphor Diagram. (Source: Khan, et al. 2014)

But why use blue emitting LEDs? The reason involves energy exchange and loss during transformation. Blue light has a higher energy frequency than white light, around 435nm (Lenk and Lenk. 2011). When the emitted blue light interacts with the phosphor, energy is lost in the form of heat resulting in a wavelength with less energy. The phosphor then re-emits the lower frequency white light, which in this case is around 450nm (Lenk and Lenk. 2011). Finally, although it is possible to combine other colored LEDs to generate the perceived white light, the use of blue LED chips and phosphors is a more energy efficient method and the one most commonly used. The spectrum changing process will become more important as this thesis will discuss potential glare hazards associated with white LEDs and blue light emissions.

Interestingly, fluorescent lights use phosphors in a very similar way. Rather than generating light visible to the human eye, fluorescent lights generate a plasma that emit radiation in the UV spectrum. Phosphors that coat the glass of the fluorescent light absorb the UV radiation and re-emit it at a lower wavelength, producing white light visible to the human eye. Both phosphor transformation processes are known as photoluminescence.

UW's Temporary Lighting Investment

Regarding the luminaires UW selected, Clear-Vu is a LED designer and manufacturer located in Islip, New York. As of 2017, Clear-Vu currently manufactures three different construction lighting systems: The FM2, FM10, and FM30 (Clear-Vu. 2016). However, the UW currently only owns two models: the FM2, a 10w, 900-lumen unit, analogous to a 20w compact fluorescent light (CFL); and the FM10, a 10w, 3,000-lumen unit, analogous to a 100w metal halide (MH).

FM2 (10W/1000 lumens)

The single LED FM2 provides 900 lumens at 10watts, and will comply with the 5 foot-candle OSHA lighting standards if placed at 10-12 foot intervals. The lamp comes with a twist and lock connector for easy installation, or a 10' whip for reconfiguration. Average lifespan of each lamp is rated at 80,000 hours before illuminance degrades by 30% (L70, LM80), which is about 6 years of continuous usage, or 10 years of use when dimmed during off-hours. The FM2 module is UL certified and is damp location listed.

FM2 – 10' spacing

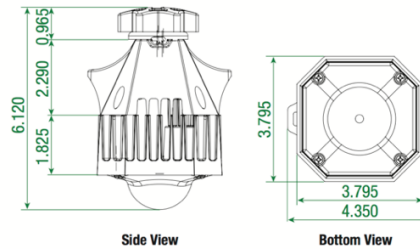

Figure 2: FM2 LED Module (Source: Clear-Vu)

Table 1: FM2 Specifications (Source: Clear-Vu)

Optic	Mechanical	Electrical
900 lumens: 10' spacing for OSHA 5 fc compliance	Operating Temperature: -30-50C	Input Voltage: 21-28VDC
Color temperature: ~4,000K	Weight: 1.3lbs	Input Power: ~10w
Lamp Life: L70 @ 80,000 hours LM79 LM80	IP66	UL and cUL approved

FM10 (30W/3000 lumens)

The FM10 provides 3,000 lumens at 30watts, and will meet the 5 foot-candle OSHA lighting standard if placed at 20 foot intervals. The FM10 also comes standard with a 10’ whip for simple installation and reconfiguration. Average lifespan of each lamp is rated at 80,000 hours before illuminance degrades by 30% (L70, LM80), which is about 6 years of continuous usage, or 10 years of use when dimmed during off-hours. The FM10 module is UL certified and is damp location listed.

FM10 – 20’ SPACING

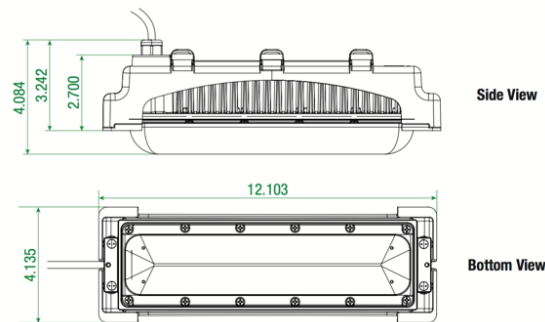

Figure 3: FM10 LED Module (Source: Clear-Vu)

Table 2: FM10 Specifications (Source: Clear-Vu)

Optic	Mechanical	Electrical
3,000 lumens: 20’ spacing for OSHA 5 fc compliance	Operating Temperature: -30-50C	Input Voltage: 21-28VDC
Color Temperature: ~5,000K	Weight: 3.3lbs	Input Power: ~30w
Lamp Life: L70 @ 80,000 hours LM79 LM80	IP66	UL and cUL approved

FPS450DT (450Watts)

The FPS450DT is an upgraded version of Clear-Vu’s FPS450 on/off power supply (ballast). In addition to providing a 450w supply that can energize 14 FM10s, 45 FM2s, or a combination of the two, the FPS450DT has an integrated, programmable time clock and dimmer, which is contractually required by current UW construction documents. The programmable power supply enables users to reduce energy consumption by 75% during off-hours (night mode). When dimmed, the FPS450DT still provides enough lighting for emergency egress applications, supporting 1-2 foot-candles of emergency lighting output to attached LED modules. The

FPS450DT still draws 0.70 watts of energy even when switched off. Lastly, the FPS450DT is UL certified.

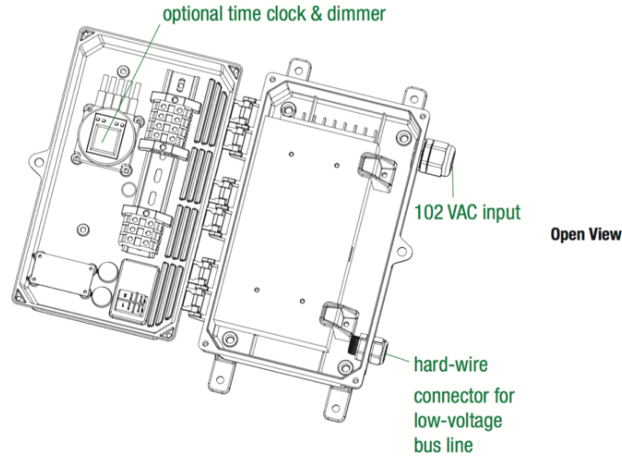

Figure 4: FPS450DT Power Supply/Ballast (Source: Clear-Vu)

Table 3: FPS450DT Specifications (Source: Clear-Vu)

Electrical	Mechanical
Input Voltage: 90-132VAC or 180-264VAC	Operating Temperature: -10-50C
Output Voltage 27.5VDC/18.75VDC	Weight 7.6lbs
Power: 450watts	Time clock enables dimmer circuit
UL Tested	-

LED Testing Standards and Ratings: L70, LM-79, LM-80, TM-21

Like other electronic products sold in the United States, there are government regulations and testing standards which LED luminaires must adhere to, to be available on the commercial market. The Department of Energy (DOE) is the primary government agency that oversees a database of tested LED products. The DOE ensures that manufacturers uphold the accuracy of their product’s reported specifications and capabilities through random testing, and distributes Energy Star ratings to luminaires that can meet energy saving requirements (DOE. 2017).

LED product safety and performance rating standards are primarily handled by UL (Underwriters Laboratory); however, there are numerous standard setting organizations with dozens of performance and safety requirements, including the International Commission on Illumination (CIE), Illuminating Engineering Society of North America (IES/IESNA), American National Standards Institute (ANSI), the Institute of Electrical and Electronics Engineers (IEEE), the Federal Communications Commission (FCC), and the International Electrotechnical Commission (IEC). There are four testing ratings that all LED consumers should be aware of: the L70, LM-79, LM-80, and the TM-21.

The L70 is a report that estimates an LED's lifespan. It denotes the time the LED takes to degrade to 70% of its original luminance output (Lenk and Lenk. 2011). Once luminance degrades by 30%, the LED is considered "dead." Unfortunately, there is no real way to gauge the accuracy of the L70 since there are multiple variables that affect LED testing and lifespan, and running an LED for 50,000 hours (about 8 years) to monitor output is unfeasible. As mentioned earlier, heat severely affects LED endurance. So how does a consumer know the performance of their LED under certain temperature conditions? The IESNA's LM-80 maintenance standard ensures that LED manufacturers are required to test at 55°C, 85°C, and a third temperature of their choosing. Additionally, manufacturers must run the lights for 6,000 hours at a minimum with a recommended testing time of 10,000 hours, and have readings taken every 1,000 hours (Lenk and Lenk. 2011, DOE. 2017).

Although the LM-80 provides guidelines for testing, the required minimum of 6,000 hours and the suggested testing to 10,000 hours do not entirely cover the lifespan of most LEDs. This is where the TM-21 comes into play. IESNA's TM-21 is a tool that helps estimate the lifespan of the luminaire outside of the LM-80 testing requirements. Furthermore, the TM-21 uses data collected from the LM-80 to develop a graphed maintenance curve (DOE. 2017). Finally, the US Department of Energy provides users with the TM-21 tool on their website to help them estimate the lifespan of their products for potential Energy Star ratings.

Finally, IESNA's LM-79 is a holistic testing standard that measures light quality produced by an LED. The report looks at five required variables, which include total light output (luminous

flux), electricity consumption, efficiency, the color of the light (chromaticity), and intensity and distribution (DOE. 2016).

Examining Clear-Vu's data sheets in tables 1 and 2, the company had their LEDs run through the L70, LM79 and LM80 tests. LM80 and L70 lifespan estimates are provided by Clear-Vu, which is stated to be around 50,000 hours. However, data from the LM79 is not readily available outside of the LED's color temperature. It is not required by manufactures to release LM79 information.

What is Traditional Temporary Construction Lighting?

To compare LEDs with the industry standard lighting, it is important to understand what traditional lighting luminaires are and how they work. This thesis defines traditional temporary lighting as “egress lighting only (corridors and stairwells) by compact florescent and metal halide fixtures and task lighting by trade contractors.” Furthermore, other systems, such as incandescent, halogen, and high intensity discharge lights will also be defined as a “traditional” source of temporary construction work lighting. The following section is a brief explanation of traditional construction lamps and luminaire systems, and their potential advantages, drawbacks, and hazards.

Florescent Lamps and CFLs

Compact florescent lamps (CFL), and florescent luminaires work by discharging an electric current through mercury gas, creating a UV emitting plasma arc (Lenk and Lenk. 2011). Although the UV radiation emitted is not readily visible to the human eye, a special phosphor coating on the inside of the bulb absorbs and reemits a blueish white light (Lenk and Lenk. 2011).

Advantages of using florescent lamps include high luminous efficacy and low brightness (ANSI. 2001). A typical CFL can run around 10,000 hours before their quality degrades or they cease to function. As mentioned earlier, the degradation of the internal phosphor coating and the accumulation of other opaque particles inside the bulb, will cause the light quality and output to slowly degrade, necessitating the replacement of the lamp (ANSI. 2001). The opaque particles

seen on the outer edges of a CFL bulb or a florescent tube is a result of powering on and off the luminaire. As the blub is switched on, heat from the plasma arc causes pieces of metal filament to be blown off, wearing away the filament and interfering with the function of the phosphor.

Regarding safety, florescent lamps contain small amounts of the toxic metal mercury, and some States' regulations require special disposal of spent lamps. However, florescent luminaires with ballasts have safety measures that reduce electricity hazards while changing bulbs. Once a lamp has been removed from the socket, the ballast switches off power, making it relatively safe if a worker happens to touch the leads. Additionally, fluorescents emit less heat than an incandescent light, around 40° C (100°F), making them somewhat safe to touch while in operation (Lenk and Lenk. 2011). Finally, the longevity of the typical fluorescent luminaire reduces maintenance hazards for workers as they will spend less time changing lights on a worksite.

Incandescent Lamps

The incandescent bulb is the oldest luminaire design on this list, with a history dating back to the early 19th century. Incandescent bulbs work by passing electricity through a tungsten filament, heating the wire to the point of releasing light. This process is known as incandescence (Lunau. 2013). Additionally, inert gas contained within the bulb extends life of the metal filament by preventing the filament from oxidizing.

Regarding color temperature, most white incandescent lights run around 2850K, producing a nice “warm” color correlated temperature (CCT). Furthermore, incandescent lights can be dimmed, which ultimately changes the warmth and intensity of the light.

Halogen lights operate in a similar way to incandescent lamps; however, halogen gas replaces the typical argon gas-filled bulb, extending their longevity and allowing them to operate at greater temperatures, and at a higher output of illuminance (Descottes and Ramos. 2011). Finally, in relation to LEDs, incandescent lights have a relatively short, 1,000 hour operating life.

Safety issues concerning the operation of incandescent and halogen lights include electricity and thermal burn hazards. A typical 40watt incandescent bulb operates at around 120°C (248°F),

which is more than enough heat to burn human skin (Lenk and Lenk. 2011). Unfortunately, when a bulb has been removed from its still active socket, contact with the leads can cause a shock or an electrocution to the unwary individual.

High Intensity Discharge (HID)

High Intensity Discharge (HID) lamps operate by running an electric charge and creating a plasma arc through either a metal halide, sodium, or xenon vapor and mercury, much in the same way a fluorescent light works (Lenk and Lenk 2011). However, instead of using a phosphor to convert UV radiation to the visible spectrum, HID lamps are able skip the phosphor and produce visible light without the coating, making them more efficient than fluorescents. Categories of HID lights are dictated by the type of pressurized gases contained within, such as metal halide (MH), sodium, or xenon. Furthermore, the gases also affect the color of light being produced, for instance sodium HID lamps produce an amber colored light. Typical HID work lights, like the Wobblelights mentioned below, tend to contain MH lamps.

HID safety concerns include explosion, fire, thermal, and UV radiation hazards. Gases within the lamp are compressed at relatively high pressures, creating an explosion and fire risk. Another side effect of HID operation are high energy UV emissions (ANSI 2001). An outer protective envelope reduces UV radiation exposure, and some lamps contain kill-circuits in the event the envelope should crack. However, there are documented radiation injuries because of cracked envelopes (Yenchek and Sammarco. 2010).

Wobblelights are common luminaire task lighting system found on construction sites. They are self-righting, portable construction lights. They are either equipped with metal halide, halogen, or CFL bulbs, and can be purchased at varying 27” or 36” base height. Figure 5 is an example of the Wobblelight system.



Figure 5: Wobblelight Models (Source: Probuilt Lighting)

Chapter 1 Summary

UW's heavy investment in Clear-Vu's LED construction lighting was a step towards industry normalization. Although LED technology is relatively new when compared with other tried and true traditional luminaires, the pros and cons of LED operation outweigh their counterparts. LEDs and Clear-Vu's models outpace traditional lighting in most operational and material benefits, for instance, they have a longer lifespan than traditional lights. Clear-Vu's FM series have a lamp life of 80,000 hours, whereas incandescent and CFLs both have spans of 1,000 hours and 10,000 hours. In addition to their longevity, LEDs remove or reduce safety hazards associate with traditional lighting. Traditional lights contain operating hazards, like bulb explosions, dangerous thermal radiation, and UV radiation. Lastly, Unlike CFLs, LEDs do not contain the toxic material mercury.

Finally, this introductory chapter is meant to set the stage and present a basic knowledge set on luminaires in terms of defining common building construction lighting systems, how those systems work, how to read testing and rating data, and what material risks those lights pose to users. This frame work will help potential users understand the discussion surrounding temporary LED construction lighting.

Chapter 2.

Safety Regulations and Recommendations

Workplace Illuminance Regulations and Recommendations

Maintaining adequate lighting, especially during indoor or nighttime activities, is an important component for work quality, productivity, and the safety and health of construction personnel. OSHA, the Occupational Safety and Health Administration, oversees and enforces Federal regulations and standards relating to the health and safety of workers in the United States. States are covered by the Federal administration up to the point where a State's regulations become more stringent than those covered by OSHA.

The OSHA General Duty Clause is a blanketing statement that protects all workers from most hazards within the workplace. The General Duty Clause section 5(a)(1) of the Occupational Safety and Health Act of 1970 states, "employers are required to provide their employees with a place of employment that is free from recognizable hazards that are causing or likely to cause death or serious harm to employees." Because the general duty clause covers all recognized work related hazards, insufficient lighting must be addressed by all states as poorly lit working conditions are a recognized hazard.

There are further Federal standards outside of the General Duty Clause that target illumination quality on construction sites. The workplace illumination standard includes illumination intensities, which ensures that minimum levels of lighting are met. Table 4 has foot-candle requirements for construction sites based on location and types of construction activities being done. Furthermore, OSHA Standard 29 Part 1926.56(a) states, "Construction areas, ramps, runways, corridors, offices, shops, and storage areas shall be lighted to not less than the minimum illumination intensities listed in Table D-3 while any work is in progress" (OSHA. 2016).

Table 4: OSHA Minimum Illumination Standards (Source: OSHA)

TABLE D-3 – MINIMUM ILLUMINATION INTENSITIES IN FOOT-CANDLES	
Foot-candles	Area of Operation
5	General construction area lighting
3	General construction areas, concrete placement, excavation and waste areas, access ways, active storage areas, loading platforms, refueling, and field maintenance areas
5	Indoors: warehouses, corridors, hallways, and exit ways
5	Tunnels, shafts, and general underground work areas: (Exception: minimum of 10-foot candles is required at tunnel and shaft heading during drilling, mucking, and scaling. Bureau of Mines approved cap lights shall be acceptable for use in the tunnel heading)
10	General construction plant and shops (e.g., batch plants, screening plants, mechanical and electrical equipment rooms, carpenter shops, rigging lofts and active store rooms, mess halls, and indoor toilets and workrooms.)
30	First aid stations, infirmaries, and offices

Adequate illumination in Washington State is regulated by the Washington State Department of Labor and Industries (L&I), which enforces the Washington Industry State and Health Act of 1973 (WISHA). Again, WISHA must follow Federal OSHA regulations; however, the state’s statute may be more stringent, if required.

Washington State’s L&I enforces title 296 of the Washington Administrative Code (WAC). Regarding workplace illumination, WAC 296-800-21005 states that, “you must provide and maintain adequate lighting for all work activities in your workplace.” (See table 5)

In terms of lighting in construction, general contractors and their subcontractors are required to provide adequate lighting for their workers on their project site in areas of work/tasks (e.g. floor finishing, conduit bending/threading, hanging sheetrock, etc.). Foot-candle requirements are further delineated by working location and activities.

Table 5: WAC Minimum Acceptable Average Lighting Level in an Area (Source: WAC)

Lighting Table		
Activity	Minimum acceptable average lighting level in an area:	Any one single measurement used to determine the average lighting level * cannot be less than:
	Foot-candles	Foot-candles
Indoor task	10	5
Outdoor task	5	2.5
Non-task activities for both indoor and outdoor	3	1.5

* *Lighting levels must be measured at thirty inches above the floor/working surface at the task*

Determining what level of illumination is required can be confusing regarding task activity or non-task activity areas. However, the term task, although not primarily defined in the WAC and ANSI, is used in context from the following sources (L&I. 2016):

Black’s Law Dictionary defines task as, *“the essential and smallest part of a job that is a unit of work differentiating from other parts of the project.”*

Merriam-Webster Dictionary defines task as, *“a piece of work that has been given to someone: a job for someone to do.”*

Non-task areas are regions within a site that contain no work/tasks being performed, and where obstructions and hazards do not exist (e.g., clear walking paths, storage areas, etc.) (L&I. 2016). If these requirements are met, then the general contractor may provide the lower 3 foot-candle level. On the other hand, if the general contractor cannot provide a clear, hazard-free task area, then they must either supply the appropriate general illumination, or provide task lighting (L&I. 2016). The WAC further states, “you must have adequate light for employees to see nearby objects that might be potential hazards to operate emergency controls or other equipment, if general lighting is not available.”

General lighting is utilized to provide uniform illumination on site. The light quality provided by general illumination does not address the needs of age-related sight impairment, nor ergonomic requirements regarding speed and accuracy, or work on small/poorly contrasted objects (L&I. 2016). However, task lighting (e.g. headlamps, portable stand lights, Wobblelights, etc.) should provide illumination necessary to bridge this gap.

The WAC standard is a reference to the minimum lighting required for employees to work safely in an area. However, the statute gives further resources in terms of non-enforceable, recommended guidelines for optimal lighting and illumination, which can be found in Practice for Industrial Lighting, ANSI/IES RP7-1979. (See table 6 for recommended illumination values)

Table 6: ANSI/IES RP7-1979 Recommendation Lighting Values (Source: ANSI/IES)

TABLE 10.4 IES ILLUMINANCE CATEGORIES AND VALUES - FOR GENERIC INDOOR ACTIVITIES			
ACTIVITY	CATEGORY	LUX	FOOTCANDLES
Public spaces with dark surroundings	A	20-30-50	2-3-5
Simple orientation for short temporary visits	B	50-75-100	5-7.5-10
Working spaces where visual tasks are only occasionally performed	C	100-150-200	10-15-20
Performance of visual tasks of high contrast or large size	D	200-300-500	20-30-50
Performance of visual tasks of medium contrast or small size	E	500-750-1000	50-75-100
Performance of visual tasks of low contrast or very small size	F	1000-1500-2000	100-150-200
Performance of visual tasks of low contrast or very small size over a prolonged period	G	2000-3000-5000	200-300-500
Performance of very prolonged and exacting visual tasks	H	5000-7500-10000	500-750-1000
Performance of very special visual tasks of extremely low contrast	I	10000-15000-20000	1000-1500-2000

A-C for illuminances over a large area (i.e. lobby space)

D-F for localized tasks

G-I for extremely difficult visual tasks

The IES recommended lighting values can be further broken down into trade and activity specific requirements. See table 7 for additional construction and manufacturing related foot-candle recommendations.

Table 7: Construction and Manufacturing Foot-Candle Recommendations (Source: ANSI/IES)

Assembly		Woodworking		Machine Shops	
Drilling/Screwing	75	Bench work	20-50	Rough Bench Work	20-50
Final Assemble	100	Gluing	20-50	Medium Bench work	50-100
Inspection	50-200	Finishing	50-100	Fine Bench Work	200-500
Welding	50	-	-	-	-

In addition to the ANSI/IES recommended lighting values, other engineering and trade societies, such as IESNA, and the American Society of Heating, Refrigerating, and Air-Conditioning Engineers (ASHRAE) have very similar lighting recommendations regarding safety and ergonomic lighting needs. However, ANSI/IES's, IESNA's, and ASHRAE's recommendations do not account for the transient nature of work on construction sites, nor do they have temporary lighting specific guidelines.

Construction site lighting compliance with the WAC statute is handled by Washington State Department of Labor and Industries (L&I). According to L&I, simple hand light meters are used to determine compliance. Foot-candle measurements can be taken to assess the work area. If the average lighting of the work area is below minimum acceptable average lighting level, then a site is out of compliance. However, L&I stated that lighting is really a judgement call, and it is easy to determine if a site is well lit or not.

Regarding the University of Washington's written general requirements for construction lighting, the documents state that the general contractor is required to provide egress lighting for corridors, stairwells, sufficient for workers to pass through the construction site to get to their work activity. In addition to their responsibility, individual trades must provide their own tasking lighting.

Challenging Traditional Construction Lighting Quality

A 2006 study conducted by Bruce W. Smith of Auburn University, found that temporary 100watt incandescent lamps, installed 10 feet apart, could not meet the OSHA foot-candle requirement under construction site conditions. This prompted Smith and his team to conduct field lighting

assessments on three construction sites. During the light level assessment, over 50% of the building area on all three sites did not meet OSHA compliance during daylight hours (Smith. 2008). Furthermore, in response to the initial three case assessment, a wider survey of thirty additional sites were conducted, all with similar findings (Smith. 2008).

Human Performance in Insufficient Lighting

Insufficient light on construction sites may have a direct impact on worker productivity, quality, and safety. Although there are few case studies about lighting and productivity, there has been no conclusive scientific evidence stating that increased lighting improves productivity and quality (Smith. 2008). The most significant factor in that regard is the quality of worker performing the activity; nevertheless, it is common sense that performing visual tasks in complete darkness is futile. However, amplifying foot-candles on a task increases visual acuity, making fine details easier to see with less eye strain (Smith. 2008).

A report on safety, health and productivity, written by luminaire and electronics manufacturer Philips, compiled and summarized studies on the effects of lighting on workers. The study noted that light has a photo-biological impact on humans, and increased foot-candle/lux levels can trigger hormonal responses in the body, raising alertness in tired workers (Van Bommel, Van Den Beld, et al. 2002). Furthermore, the Philips report found a 3-11% increase in productivity with an increase in lighting levels (See table 8).

Table 8: Work Productivity Increases by Activity (Source: Philips)

Type of work	Lighting level (lux)		Increase in task performance (%)	Reduction in number of rejects (%)
	Before	After		
Camera assembly	370	1000	7	-
Leather punching	350	1000	8	-
Composing room	100	1000	30	18
Fine assembly work	500	1500	28	-
Metal industry	300	2000	16	29
Difficult visual tasks in the metal industry	500	1600-2500	10	20
Miniature assembly	500-1000	4000	-	90
Weaving mill	250	1000	7	-

Next, the report cited a 1995 study on lighting levels and accident rates, claiming that as lighting

levels increase, work related injuries decrease (see figure 6). Interestingly, examining the graph published in Philip’s report reveals a contradiction--as illuminance increases, the rates of cuts and other injuries also increases.

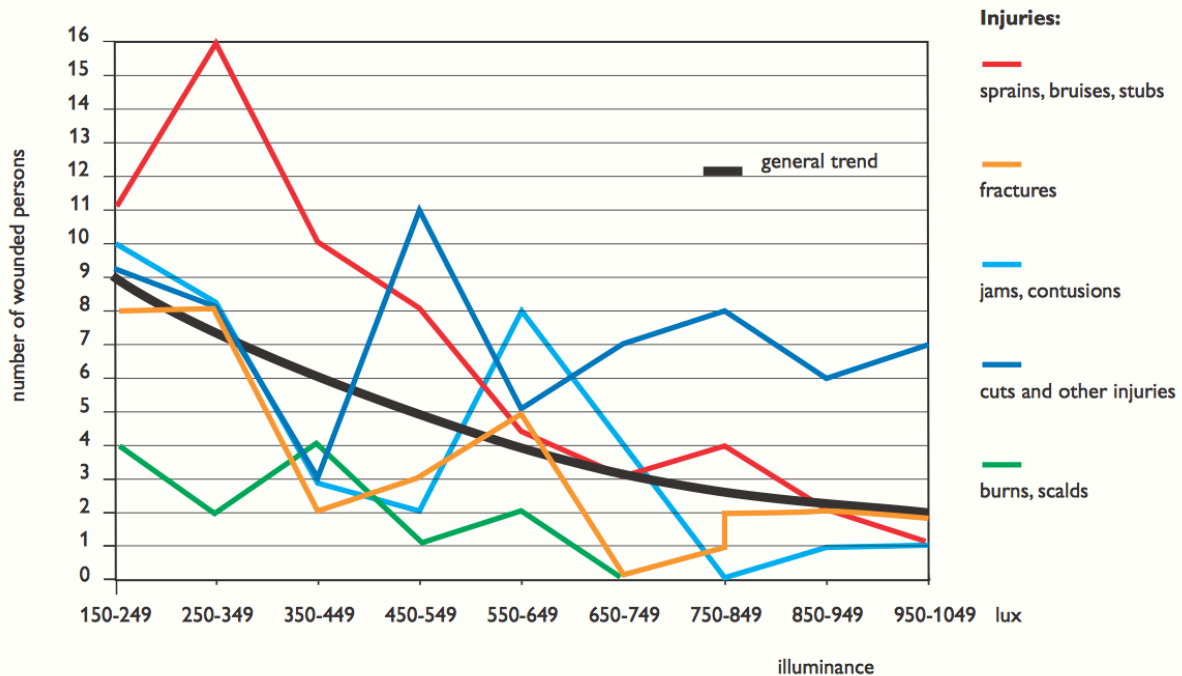

Figure 6: Illuminance Levels and Rates of Injuries (Source: Philips)

Although an industry giant’s report on increasing lighting quality should be met with some skepticism, insufficient light quality is a known safety hazard in construction. Effects of poor lighting influence three aspects of human performance: visual performance, the circadian system/alertness, and mood/motivation (Boyce. 2014). A diagram published in the book Human Factors in Lighting highlights these three routes in which human performance can be affected (see figure 7). Further effects related to poor lighting include, lowered spatial awareness, the inability to accurately judge shapes and movements of objects, and a diminished sense of well-being (Boyce. 2014). Health risks associate with light quality include, eye strain, headaches, seasonal affective disorder, and disruption of circadian rhythms (sleep loss) (Boyce. 2014).

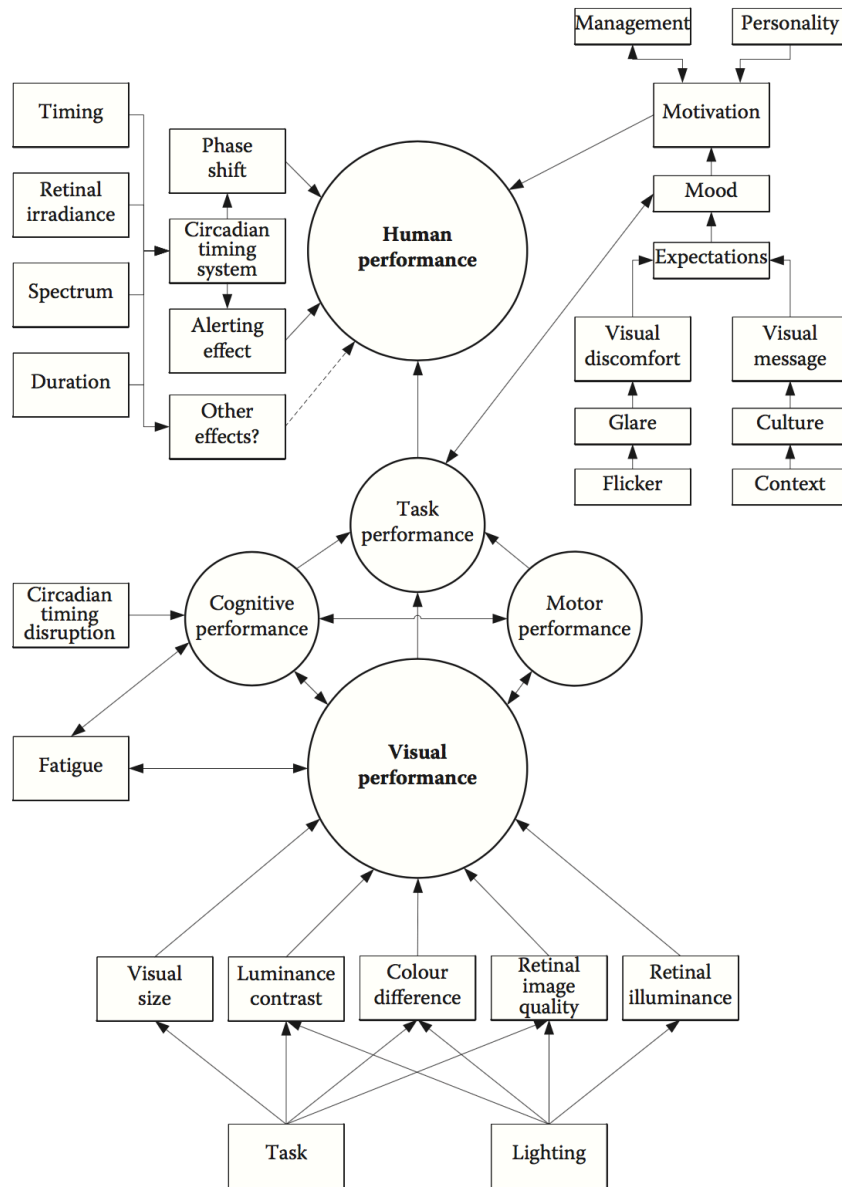

Figure 7: Effects of Light on Human Performance (Source: Human Factors in Lighting)

Visual Performance: Contrast, Color, Illuminance and Glare

There are four lighting variables that affect visual acuity and performance: luminance contrast, color, image quality, and retinal illuminance (Boyce. 2014).

Luminance contrast is the difference between an illuminated object in the foreground relative to the illuminance of the background (Boyce. 2014). The difference in lighting between subject and background affects the ease of which the human eye can identify and differentiate between the

two. An object that is easy to spot because of the difference in lighting is said to have a higher luminance contrast. Furthermore, the color of the subject, background, and luminance source can affect the contrast of the subject, making it harder for the human eye to focus in on the object. However, color contrast between subject and background can render luminance contrast moot. For instance, if you placed a white golf ball on an asphalt road at dusk, it would still be relatively easy to differentiate between the ball and the asphalt.

Lighting also affects image quality and “sharpness” of a subject. Although it is primarily the reflective quality and the visual content of the subject that matters, visible light in higher powered wavelengths (smaller wavelengths) causes the pupil to shrink, creating a more focused image (Boyce. 2014).

Retinal illuminance is the amount of light able to enter the eye. Factors that influence this are the amount of luminance and illuminance from an exterior source, such as light reflecting off a wall or light emanating from a lamp, and the physiological barriers of the eye, such as pupil size and lens quality (Boyce. 2014). Age and health of the eye also affects retinal illuminance as cataracts and lens degradation affect the ability of the eye to receive light. Conversely, older individuals are less affected by blue light and glare resulting from age-related yellowing of the eyes’ lenses (Tosini, Ferguson, et al. 2016).

Finally, it is possible for luminaires to create too much luminance, causing light to be reflected or misdirected towards the eye, negatively affecting visual and human performance. The discomfort triggered by bright, misdirected light is called glare. Although tolerable in certain circumstances, glare can contribute to an alteration of visual space and depth, creating a barrier of blinding light, hiding objects intended to be seen (Descottes and Ramos. 2011).

There are two types of glare: disability, and discomfort glare. Disability glare creates a veiling and blinding sensation within the eye, making it hard to see, and potentially creating a dangerous situation for workers’ awareness (Tashiro, Kimura-Minoda, et al. 2015). Disability glare can also be hazardous, causing a painful sensation in the eye and forcing those exposed to squint or look away. Conversely, discomfort glare is a psychological sensation that causes those exposed to be

irritated or bothered by the excess light (Tashiro, Kimura-Minoda, et al. 2015). However, discomfort glare can elicit physiological and psychological health effects, such as headaches and stress (Tashiro, Kimura-Minoda, et al. 2015).

On the other hand, bright, inadequate, or obstructed lighting can produce deep shadows. Shadows further hamper visual acuity by hiding objects in darkness. However, a combination of adequate lighting and shadow can create high luminance contrast to physical objects, revealing three-dimensional form and space (ANSI/IES. 2001). Regardless, the presence of glare and shadows on site can contribute to hazardous working conditions, and decrease visibility (Boyce. 2014).

How LEDs Can Potentially Increase Safety on Worksites

LEDs have the potential to eclipse traditional lighting sources as a means to safer working environments. LEDs can provide better illumination, are more resilient to physical damage, and require less maintenance than incandescent, compact fluorescent, or metal halide luminaires. Unfortunately, there are very few studies with quantitative data correlating the impact of lighting on workplace safety; however, one study did manage to gather accident rates in relation to workplace lighting.

Although not completely related to the construction site environment, a study on accidents attributed to work lighting in the mining industry was published in 2010. In conjunction with the National Institute for Occupational Safety and Health (NIOSH) and the US Mine Safety and Health Administration (MSHA), accident and injury data from years 2002-2006 was quarried and coded to find accidents related to lighting (Yenchek and Sammarco. 2010). The study found that during these years a total of 140 accidents occurred, with primary injuries relating to the following categories: sprains/strains (40), laceration/puncture wounds (39), fractures/chips (18), and contusions/bruises (13) (Yenchek and Sammarco. 2010). Furthermore, 53% of the accidents were related to maintenance of work lights, such as changing light fixtures and replacing an expended bulb; and of amongst those accidents, 37% resulted in time lost, each averaged around 78.4 days per incident (Yenchek and Sammarco. 2010).

Changing a light bulb can be surprisingly dangerous, and the placement height of luminaires can further pose a hazard to electricians or laborers as the study further states at least eleven employees were hurt when they either fell off a ladder, or slipped while dismounting from a surface (Yenchek and Sammarco. 2010). Other workers were hurt as they were changing a light fixture, receiving hand lacerations from hand tools as they spliced wires or opened covers. Finally, the study notes that one worker was shocked while changing a bulb, and several others received eye injuries when mismatched bulbs were incorrectly inserted into sockets with higher voltage, resulting in bulbs exploding (Yenchek and Sammarco. 2010).

Although most of the documented injuries were related to maintenance, standard operation of non-LED lights resulted in thirty accidents during the study's period. Some luminaire systems, like metal halide lamps, can emit hazardous amounts of UV radiation if their outside filters become damaged. In that regard, three workers suffered radiation burns to their eyes and skin as result of exposure to a broken 1000watt mercury flood light, and two more workers were exposed to unshielded ultra-violet radiation from a broken metal halide lamp and received burns to their eyes (Yenchek and Sammarco. 2010). Finally, one worker was burned when their face and neck contacted an operating light, and another worker was burned when vapor from a solvent he was using contacted the light, igniting and burning the worker's face and neck (Yenchek and Sammarco. 2010).

The NIOSH mining study concludes that LEDs can increase safety by reducing maintenance related hazards, such as slips, trips and falls, and removing dangers associated with traditional lighting, like thermal, radiation, and electricity hazards. Moreover, considering their construction when compared with other luminaires, LEDs are a robust lighting system. LED lamps do not catastrophically fail once they reach their lifespan, rather their luminance output degrades slowly over time. The life expectancy of a typical LED can exceed over 50,000 hours before luminance degrades by 30%, but that is not to say that other components of an LED luminaire, such as a ballast/power source, cannot prematurely fail on their own.

Unfortunately, accidents and injuries described in the NIOSH study are all too common, and many are often fatal. Conducting a quick search through OSHA's Accident Report Detail

database quickly reveal well over a hundred incidents. Even highly trained and experienced employees unfortunately fall victim to lighting related hazards. OSHA accident 200841120 details a fatal accident that occurred on August 2, 2005 when a journeyman electrician was changing bulbs and ballasts on an 8-foot-long fluorescent luminaire energized to 277 volts. The electrician touched an exposed and energized wire in the ballast and was electrocuted. Unfortunately, the electrician was not wearing appropriate personal protective equipment (PPE), nor was the scissor lift he was occupying properly grounded.

Nighttime Highway Construction Projects

Outside of building construction and mining, civil engineers and road construction contractors are also relying on LED technology to keep workers and the public safe. Nighttime highway construction lighting is a difficult balancing act between providing enough task illumination for workers, alerting on-coming traffic, reducing light glare, and increasing visibility for pedestrians and drivers (Odeh. 2010). It is no surprise that nighttime construction poses a higher safety risk for highway construction workers, as researchers found an 87% increase in injuries during nighttime operations (El-Rayes, K., et al. 2008). However, to combat roadwork hazards associated with poor light quality and glare, the industry has started to incorporate LEDs into temporary luminaire systems common in the industry, such as trailer-mounted light towers, balloon lights, and headlamps. In 2011, the New York Department of Transportation (NYDOT) conducted a survey amongst highway construction and trade organizations, and found that 45% of respondents were interested in adopting LEDs for roadwork illumination (Rea, M., et al. 2014). At the same time, the NYDOT also found that 56% of contractors were already implementing LEDs as signaling devices, as LEDs were more effective in controlling traffic than non-LED equipped signs and displays (Rea, M., et al. 2014).

In addition to the survey, the NYDOT conducted a field test of various halogen, MH, florescent, and LED luminaires for illumination quality, durability, portability, and glare. The field test found that LED light quality was rated positively, although the lighting system (e.g. tower light versus balloon light) made a difference regarding glare and lighting intensity, as balloon lights produced a less intense, yet more diffuse light (Rea, M., et al. 2014). However, the study noted

that LEDs' have superior lighting control over other traditional lights, and have the potential to reduce glare exposure to workers (Rea, M., et al. 2014).

Metal Halide Near-Miss

On August 25th, 2008, a 400watt metal halide Wobblelight caught fire during off-hours. The near-miss incident report provided by Skanska states that there are several different factors which may have lead the light to catch fire and melt: metal halides produce a lot of heat; rain over the weekend may have caused the lamp to short circuit; or the bulb was defective.



Figure 8: Bravern Wobble Light Fire (Source: Skanska)



Figure 9: Bravern Wobble Light Fire (Source: Skanska)

Chapter 2 Summary

Lighting related injuries and fatalities could be reduced through proper training and PPE; however, removing the hazard all together would be a more effective option, which is one of the reasons why the UW is trying to change the narrative on temporary construction lighting.

Lighting and quality illumination are inseparable components to worker safety on construction sites, which is why Federal and State illumination regulations exist. Research has shown that increasing task lighting and general illumination for workers increases visual and human performance, and reduces negative physiological and psychological health effects, such as eye strain, headaches, depression, and stress. Furthermore, there is some evidence that increased lighting quality can reduce onsite injuries, as was referenced by Philips in the 1995 metal industry study.

On the other hand, luminaires can play a role in workplace hazards and injuries. Although operation and material safety was covered in Chapter 1 of this thesis, the NIOSH and MSHA case study, and the field research conducted on 33 construction sites lit with traditional lighting found that traditional lighting may not be adequate and is contributing to workplace accidents. To reiterate the 2010 NIOSH study, 53% of accidents occurred due to maintenance of lights.

These accidents can be reduced by switching to an LED-based lighting system, as it would require far less maintenance than traditional lights, and do not express hazards associated with other lighting systems, such as UV radiation, explosion, and thermal hazards.

The safety benefits of LEDs have also caught the attention of other industries outside of mining and building construction. Nighttime highway and civil engineering projects have started incorporating them into their projects, replacing MH, and halogen bulbs in trailer-mounted light towers and balloon lights with LEDs.

Chapter 3.

UW Developed Study: Bothell Phase 3

2012 UW Bothell Phase 3

In the spring of 2012, UW began construction on a new facility, the Bothell Science and Academic Building (UWB P3). UWB P3 consists of four levels and a basement, totaling 74,000 square feet, with a project value of 68 million USD. Furthermore, as the project's primary source of temporary lighting, the University invested in 285 Clear-Vu LED modules as no other suppliers were available at the time (Huang. 2014). The installed temporary lighting became the subject of a 2014 case study written and developed by University of Washington Construction Management graduate student, Yi Jie Huang.

To better understand how UW's new luminaire system worked, Huang's case study methodology looked at UWB P3's lighting through: (1) installation method; (2) labor, material, and energy cost comparisons; (3) stakeholder interviews; and (4) a qualitative survey of workers. The following information pertaining to the Bothell project is a summary and analysis of Yi Jie Huang's work. Furthermore, Huang's research served as a springboard for the ARCF case study and this thesis.

Installation Method at UWB P3

Installation of the Clear-Vu system was relatively unique. Rather than relying upon lengths and lengths of wire hooked to the ceiling or strewn across walkways, Nelson Electric, the electrical contractor on site, embedded the luminaire's wires directly into the concrete slab. This method took more planning and coordination with other trades onsite, particularly ironworkers, adding to the planning costs of the building (see figure 10). However, the extra planning and installation method reduced clashes with reinforcement steel, and increased safety by reducing potential trip hazards because of loose cabling (Huang. 2014). Moreover, this installation method was only possible because of the low-voltage characteristic of the LEDs.

Once the locations of wire penetration points had been confirmed, wire inserts and cable whips were placed in the formwork, and extended through into the area below. During the placement of concrete, an electrician from Nelson Electric supervised the embeds and wires, ensuring they were not disturbed during the pouring and curing process (see figure 11). Finally, as the concrete

cured to strength, the LED lamps were installed so they could be turned on once the formwork had been stripped. This allowed for immediate use of the LEDs following the curing of the slab.

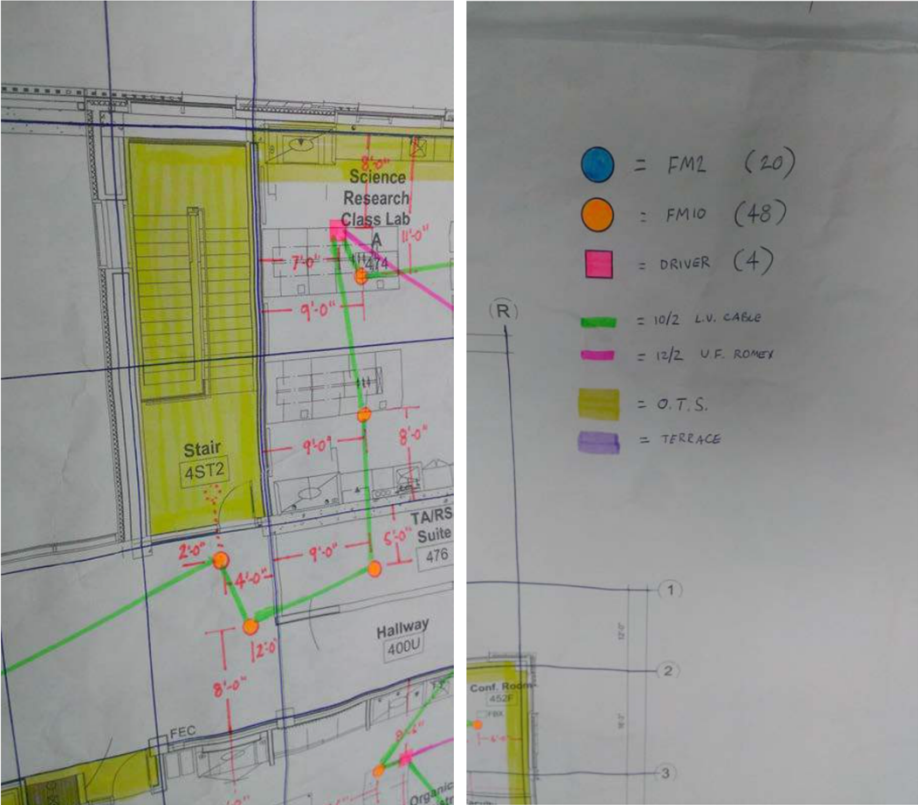

Figure 10: Preconstruction Planning of LED Inserts (Source: Nelson Electric)

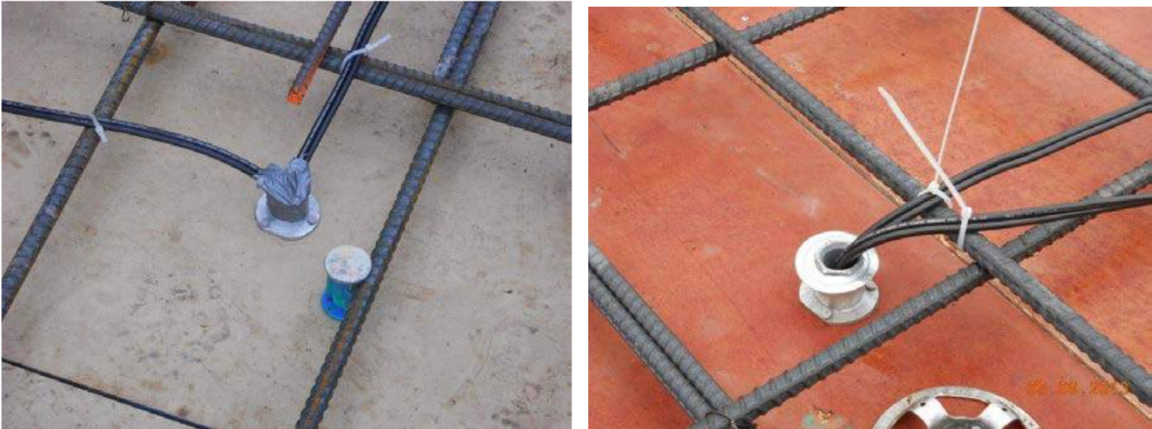

Figure 11: LED Wire Inserts (Source: Nelson Electric)

Estimated Costs and Energy Use at UWB P3

Table 10 is an estimate of installation and power use expenditures provided to Huang by Nelson Electric. There is a 151% difference in cost and energy use between a 150watt HID running only 12 hours a day, versus the LED system, which runs 24 hours a day, but at a 50% power cut afterhours. The total Clear-Vu LED system estimated usage for kilowatt hour (kWh) during a 12-hour day was 25,080kWh, whereas the 12-hour use on the HID system was 268,056 kWh, a 165% difference, and a 969% increase in energy use. Ultimately, the cost comparison estimates developed in Huang’s case study denote a much higher entry cost regarding LED material and installation expenses; however, when compared with a similar traditional system, the LEDs save on maintenance, energy and removal costs over the course of the project’s lifetime (see figure 12).

Regarding the higher installation and material costs, Nelson was tasked with providing at least 5 foot-candles across the entire site, which differs from the traditional use of temporary construction lighting of only illuminating corridors and stairways. Below in table 9, Nelson Electric compares a traditional lighting schedule for just corridors and stairways with a 5-foot-candle requirement. Additionally, as mentioned in the installation method section, installation for the LED system also costed more because of the extra time it took to plan and layout the concrete inserts.

Table 9: Cost and Lighting Schedule Comparisons (Source: Yi Jie Huang)

Description	Traditional setup (only corridors and stairwells)	5 foot candle requirement setup
Number of metal halides	68	204
Estimated cost (HID)	\$20,686	\$104,692
Number of LED	135	285

Table 10: Nelson Electric Cost Estimate (Source: Nelson Electric)

	LED Tim Nelson				HID (5fc) Tim Nelson			
	Quantity	Unit	Rate	Amount	Quantity	Unit	Rate	Amount
Material								
Cable	6,120.00	LF	\$ 0.05	\$ 306.00	5,730.00	LF	\$ 0.52	\$ 2,979.60
Power supply/controller connection	20.00	EA	\$ 47.89	\$ 957.80	(Stairs) 520.00	LF	\$ 0.52	\$ 270.40
Light fixtures	285.00			\$ 52,689.00	204.00	EA	\$ 185.00	\$ 37,740.00
Sub-total				\$ 53,952.80				\$ 40,990.00
Installation								
Install cable	6,120.00	LF	\$ 1.92	\$ 11,750.40	5,730.00	LF	\$ 3.20	\$ 18,336.00
Install power supply/controller	20.00	EA	\$ 639.30	\$ 12,786.00	(Stairs) 520.00	LF	\$ 3.84	\$ 1,996.80
Install fixtures	285.00	EA	\$ 22.38	\$ 6,378.30	191.00	EA	\$ 30.27	\$ 5,781.57
Sub-total				\$ 30,914.70	(Stairs) 13.00	EA	\$ 49.45	\$ 642.85
								\$ 26,757.22
Maintenance								
Maintenance & repairs	52.00	HR	\$ 63.93	\$ 3,324.36	416.00		\$ 63.93	\$ 26,594.88
Fixtures replacement								\$ 390.00
Sub-total				\$ 3,324.36				\$ 26,984.88
Removal								
Removal of fixtures; Removal/Abandon cables	60.00	HR	\$ 63.93	\$ 3,835.80	160.00	HR	\$ 63.93	\$ 10,228.80
Sub-total				\$ 3,835.80				\$ 10,228.80
TOTAL				\$ 92,027.66				\$ 104,960.90
Power costs								
223 FM10 (100% for 12 hours)	13,674.36	kWH	\$ 0.09	\$ 1,251.20	150W HID (12hrs) 268,056.00	kWH	\$ 0.09	\$ 24,527.12
223 FM10 (50% for 12 hours)	6,837.18	kWH	\$ 0.09	\$ 625.60				
62 FM2 (100% for 12 hours)	11,405.52	kWH	\$ 0.09	\$ 1,043.61				
62 FM2 (50% for 12 hours)	5,702.76	kWH	\$ 0.09	\$ 521.80				
Sub-total	37,619.82			\$ 3,442.21				
TOTAL				\$ 95,469.87				\$ 129,488.02

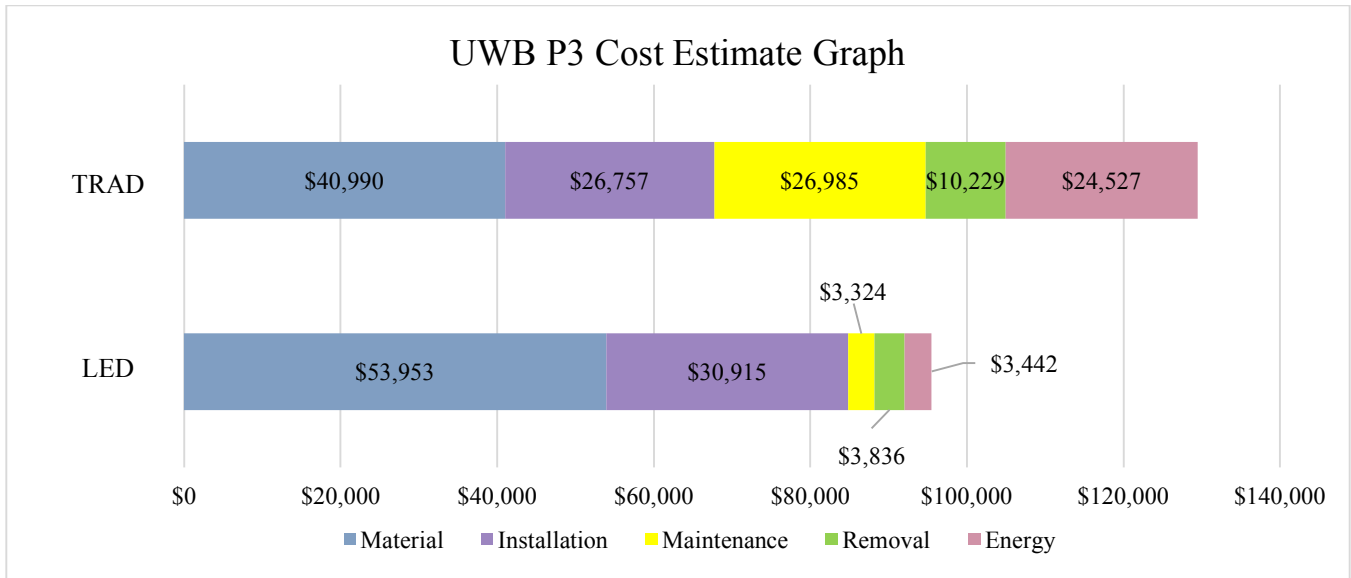

Figure 12: UWB P3 Cost Estimate Graph

UWB P3 Stakeholder Interviews

To understand the benefits, drawbacks, and industry perceptions of temporary construction lighting, Huang’s case study conducted a series of interviews with stakeholders involved with the UWB P3 project. Interviews were performed by Yi Jie Huang in a roundtable-style. The first interview was carried out on January 24, 2014, which included CPD construction manager, Mark Sweeters, and Nelson Electric’s foreman, Eric Unseth were interviewed. A follow up interview was accomplished on March 25, 2014, with CPD’s Mark Sweeters, Lease Crutcher Lewis’ construction manager, Brian Aske, Nelson Electric’s owner, Tim Nelson, and foreman Eric Unseth.

The interviews revealed some benefits of installing the LED system including, immediate use of temporary lighting following curing of concrete, which provided lighting to trades as construction activities progressed. Furthermore, since lighting was provided across the entire site rather than just corridors and stairwells, illumination in rooms got brighter as light reflected off drywall being installed. Next, because the luminaires were easy to install and the concrete inserts were hidden from view, the LED system could remain in the building until permanent lighting had been installed and energized.

One problematic issue regarding the unique installation method was accidental drilling and cutting of embedded cables in the concrete slab. On at least twelve occasions, workers accidentally cut embedded cables, which tripped circuit breakers in the area, cutting off temporary lighting on that breaker. Although this issue was relatively easy to repair if the cable and drilling location could be identified.

Another issue concerning the LED lighting was that the lights faced downward. Although not problematic for trades working below the lights, HVAC trades had to provide their own tasking lighting for up-lighting requirements as their work was typically focused above the luminaires.

The stakeholders for Nelson Electric and Lease Crutcher Lewis were asked about their perceptions on temporary construction lighting. One construction manager replied that lighting is generally up to the contractor, so long as they meet contract provisions. Furthermore, contractors try to find the cheapest means and methods possible since the lighting is only temporary, and temporary lighting specifics are rarely considered as they are often bundled with temporary power costs. Finally, it was noted that temporary lighting costs were always sacrificed due to the nature of the construction bidding process.

Lastly, there seemed to be confusion amongst contractors regarding OSHA and WAC definitions regarding “general illumination” and “work/task area.” This confusion was also apparent for contractors and project managers on the Animal Research and Care Facility case study. The belief is that contractors are only responsible for providing general illumination for workers to safely move around site, and that trades and subcontractors were responsible for making up the foot-candles by providing their own task lighting. Furthermore, on the ARCF project, there was confusion regarding what a task/work area is. This led to an interview with L&I, pointing to the Merriam-Webster’s and Black’s Law Dictionary definition on “task”, which is stated in Chapter 2.

The confusion regarding lighting requirements and task definitions could be addressed by rewording and specifying temporary lighting requirements and flushing out WAC requirements

in a project’s contract documents. However, neither the UWB P3 nor the ARCF project documents do this, they instead just refer to the WAC lighting requirement.

UWB P3 Worker Survey

Finally, Huang conducted a qualitative survey of workers involved with the project. With the help of safety officer Chilly, a total of 21 survey responses were collected. Below is a cursory overview of Huang’s survey.

Survey Question 11 provides a good overall impression of workers’ opinion on the temporary lighting use at UWB P3. The question asks workers to rate on a 5-point scale (1 bad, 2 poor, 3 fair, 4 good, and 5 excellent) how they felt about LED lighting on site in relation to their experiences with traditional work lighting. A quick look reveals that most of the workers on site had a positive experience working with UWB P3 temporary LED lighting system while workers’ experiences with traditional sources were less positive. Opinions for LEDs ranged between 3.5 and 4.0, while opinions for traditional lighting were a bit lower, ranging between 2.4 and 3.2. (See table 11)

Table 11: Average Rating of Positive Lighting Attributes (Source: Yi Jie Huang)

Description	Average rating	
	LED	TRAD
Amount of Light Provided	3.70	2.69
Consistent and well distributed	3.50	2.38
Productive	3.75	2.94
Visually comfortable	3.84	2.73
Safe operation of work	4.00	3.20

Scores for negative attributes of the LED lighting system were also collected in the survey, which can be seen in table 12. Workers could rate their experiences on a scale from 1 to 5, where 1 disagree, 2 somewhat disagree, 3 neutral, 4 somewhat agree, and 5 agree. Again, workers

had a more negative outlook of traditional lighting than the LEDs, with opinions on traditional lighting ranging from 3.06 to 3.25, and opinions on LEDs ranging from 2.10 to 2.43.

Table 12: Combined Average Rating of Negative Attributes (Source: Yi Jie Huang)

Description	Average rating	
	LED	TRAD
Distracted from work	2.43	3.25
More disruption	2.10	3.06
More coordinated efforts	2.10	3.13

Other qualitative findings include written responses noting the glare and loss of contrast created by the LED lights. An acoustic ceiling tile worker stated, the lights *“made it more difficult do to the directional nature of the light shining down impeding your ability to look up towards the light to see past it”* when asked whether the LEDs were more helpful (Huang. 2014).

Responding to the same question, another worker stated, that LED lighting *“lit up most areas well, but could be blinding at times when working overhead (Huang. 2014).”*

Despite the issues of glare and loss of luminance contrast, one electrician stated an increase in productivity and reduction in safety hazards resulting from *“no cords to trip over”* (Huang. 2014).

A more detailed look at the survey findings will be done in the second case study, as combined survey findings from both UWB P3 and ARCF are analyzed.

UW LED History Continued

After the completion of UWB P3 in 2014, LED modules were removed and redeployed to UW Bothell’s 36,000 square foot Activities and Recreation Center construction site. Upon completion of the Activities center, the lights were moved to UW’s main Seattle campus to be further used on campus projects.

March 2015, construction on the new Nanoengineering and Sciences (NanoES) building began. Construction is scheduled to continue until July 2017. Again, to maintain 5 foot-candles across the 78,000-square-foot site, Valley Electric installed 319 LEDs and 22 drivers. 287 LED modules were redeployed from UW Bothell. An additional 70 LEDs and 4 power supplies were purchased to make up the difference.

During the construction process it was found that nine FM10s and one ballast were broken. Lights and power supply were replaced at a material cost of \$2,240. The reason why the lights and ballasts were broken is unknown---they were dead on arrival.

Table 13 is a material schedule with estimate labor hours provided by Hoffman and Valley Electric. Figure 13 is a visual representation of estimated costs accrued at Nanoengineering and Sciences.

Table 13: Material Schedule and Labor Hours at NanoES

Level	Driver	FM10	FM2	Est. Cabling	Est. Labor Hrs.
B1	4	15	0	399	82.97
G	4	38	40	1722	311.66
01	4	54	5	1124	206.28
02	4	41	25	1249	227.88
03	4	5	36	924	170.22
04	3	6	35	924	170.22
Total	22	159	141	6342	1169.23

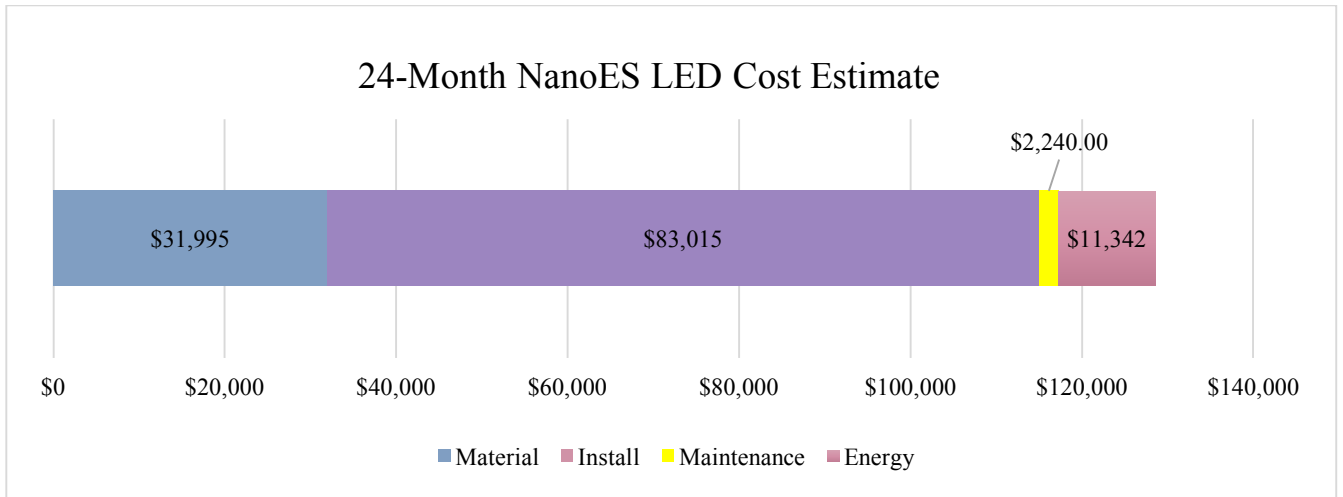

Figure 13: 24-Month NanoES LED Cost Estimate

On July 2016, construction began on the new Life Sciences building. It is estimated that 570 LED modules and 8,000 feet of cabling from the Animal Research and Care Facility will be redeployed onto site. Furthermore, an estimated 255 additional LED modules and 12,000 feet of cabling will be purchased to provide code-adequate lighting.

Redeployed modules and materials from ARCF is estimated to save around \$74,700 in material costs. Figure 14 is a 12-month visual representation of estimated costs for LED temporary lighting at Life Sciences.

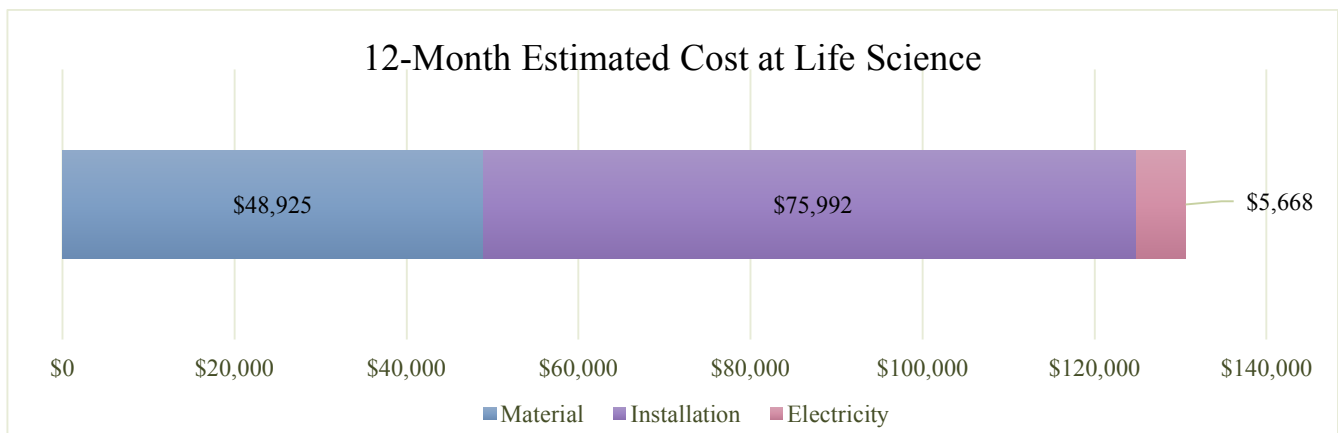

Figure 14: 12-Month Estimated Cost at Life Science Building

Chapter 3 Summary

Huang's case study set the groundwork for further LED research on UW campus projects by collecting a solid baseline of information, and outlining an LED research methodology.

Furthermore, UWB P3 was UW's first foray into investing in a LED system, and requiring LED use for generally construction illumination.

Nelson Electric's implementation of the LED requirement was an efficient use of an expensive resource. Installing wiring embeds into the concrete slab maximized deployment times of the lights. Although the embeds required more coordination with trades, the benefits include increased safety through greater lighting quality, and a reduction in investment waste as the imbeds allowed the temporary system to be used up until permanent lighting was switched on.

Huang's cost-benefit analysis found that LEDs are initially more expensive to invest in, yet save on energy and maintenance expenses over a project's duration. UWB P3 estimates noted that LEDs cost an extra \$13,000 to invest in, yet can potentially save the project ~\$34,000 in maintenance and energy expenditures.

Next, Huang conducted a qualitative survey, asking UWB P3 workers how Clear-Vu's LEDs compared with traditional lighting. Overall, workers had a positive opinion of the LEDs when compared to traditional lighting alternatives. During the cursory overview, opinions for LEDs ranged from fair to good, whereas traditional lights scored in the poor to fair range.

Furthermore, write-in responses discovered that glare was an issue for some workers. This data point became important as workers at the ARCF also commented about glare, and the resulting responses motivated an investigation into LED glare.

Finally, stakeholder interviews revealed an industry obstacle that may complicate the normalization of LED lighting. The nature of the competitive bidding process forces contractors to use cheaper temporary lighting. Although the winning contractor may benefit from project-long maintenance and energy savings, project owners will not see the financial benefit to using LEDs.

Chapter 4.

Case Study 2: Animal Research and Care Facility

Case Study 2: Animal Research and Care Facility Site

Demolition of the old UW Annex facility and construction on the new Animal Research and Care Facility (ARCF) began in January 2015. The ARCF consists of an 85,000 gross square foot, underground research facility and associated utilities, with a contract value around 100 million USD. Site improvements along NE Pacific Street, Portage Bay Vista and Boat Street include new landscaping and sidewalks. In addition to the new facility, adjacent building BIOE will receive additional renovations, including the expansion of the underground loading dock. Besides the new construction, the building will provide a worker friendly environment that is safe and efficient, and includes elements to enhance the wellbeing and worker satisfaction of facility staff. Like the previous campus projects, the ARCF incorporated the Clear-Vu lighting system and became the topic for a second case study.

May 2016, work on a second case study was commissioned by the UW CPD as part of a summer research internship. The author, working with CPD senior project managers Jeff Angeley and Steven Babinec, wrote the case study to further develop knowledge regarding the deployment of construction LEDs on campus projects. The report builds upon information from UWB P3's case study and follows a similar research methodology. The ARCF second case study looks at: (1) installation method; (2) labor, material, and energy costs; and (3) conducts a qualitative survey of workers. The report further runs a light meter reading and energy tracking study, collecting quantitative data to understand energy efficiency, lighting quality, and regulatory compliance of the LEDs.

ARCF Contract Provisions and General Requirements

Construction documents for the ARCF project contain contractual language regarding lighting systems and work-lighting conditions on site. Unlike other construction projects, the UW's contract specifically states that contractors must implement a low-voltage, temporary LED lighting system where possible. To be more specific, site requirement for temporary support facilities, in section 01 50 00 Clause 1.6E states: "Contractor shall provide and maintain a low voltage LED light system with provided equal to or greater than the minimum illumination requirements of WAC 296-800-21005.

Further stipulations on qualities regarding characteristics of implemented LED lighting systems include: “The LED light system shall be approved for use without protective cages and should not require replacement during the course of the project construction. Where more high intensity light is required, LED equivalent to metal halide can be utilized. The low voltage system shall provide flexibility for placement of the light in areas that require relocations during the course for the project. LED drivers shall be utilized that provide the necessary output and incorporate time clock and dimmer function in order to reduce light output at night.”

Finally, the Contractor must submit a coordinated temporary lighting plan for Owner review and acceptance prior to notice to proceed. The plan shall include planning, layout and phasing, and be integrated into the job logistic plan and the Contractor’s Site Specific Safety Plan.

These contract stipulations alter a contractor’s means and methods, which generally leaves temporary lighting up to the winning bidder. As stated by Nelson Electric and Lease Crutcher Lewis in case study one, temporary lighting is left up to the winning bidder, and lighting is often sacrificed to make a bid more competitive. The new contract language forces contractors to consider the new lighting requirements.

Installation of Lights at ARCF

Cochran, Inc. was contracted to design, install, maintain, and remove the temporary lighting at ARCF. Starting with a preconstruction design, photometric software was used to establish luminaire location and quantities for illumination requirements (see figure 15). Following the photometric design, a reflected ceiling plan was used for placement and installation of temporary and permanent LED lighting (see figure 16).

According to original invoices provided by Cochran, the project purchased 812 Clear-Vu LED modules and 41 Clear-Vu power supplies. 322 FM10s and 490 FM2s were installed on site with an additional 156 FM10 being purchased and installed as permanent lighting in interstitial areas.

However, upon discovery of purchase invoices and the completion of a Seattle City Light energy rebate in November 2016, the total number of LED modules was reduced to 500 temporary lights, and 137 permanently installed FM10s.

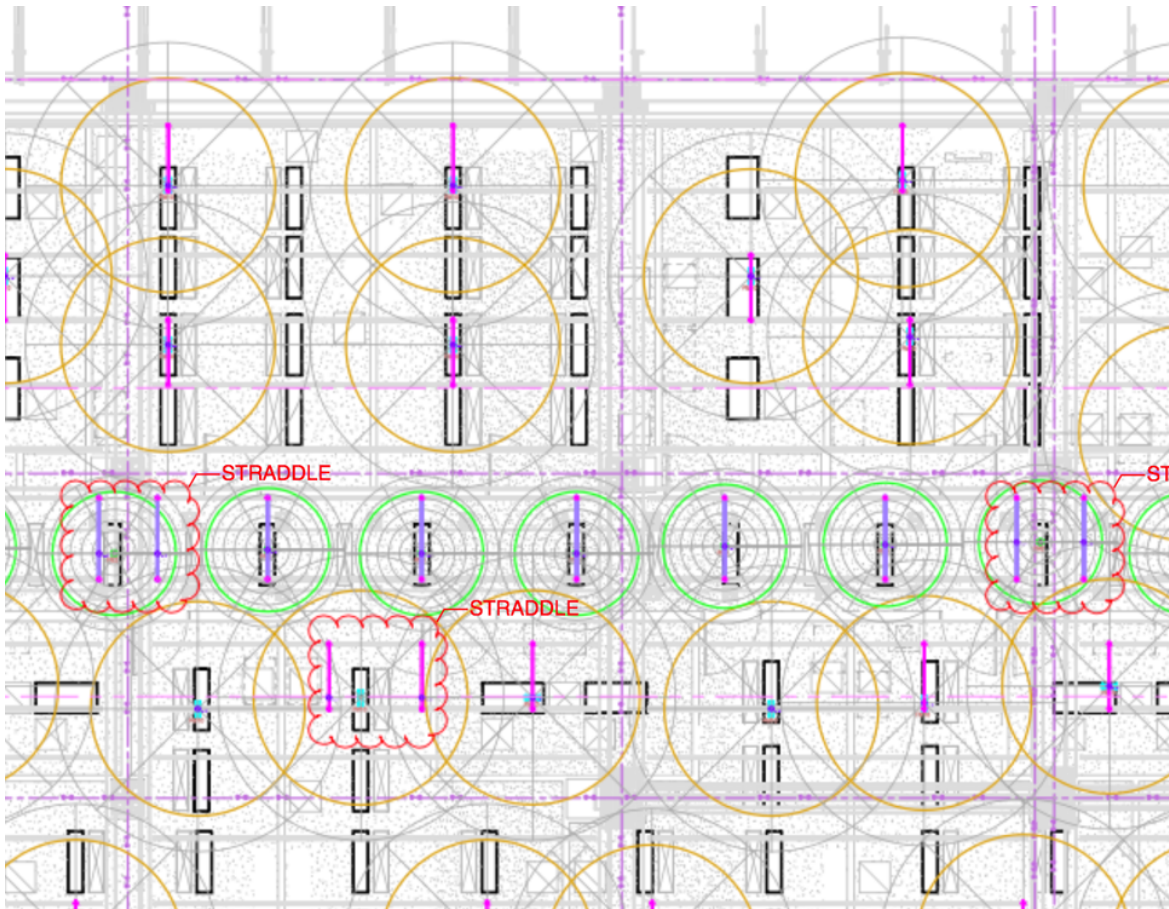

Figure 15: Photometric Plans of ARCF LEDs (Source: Cochran Electric)

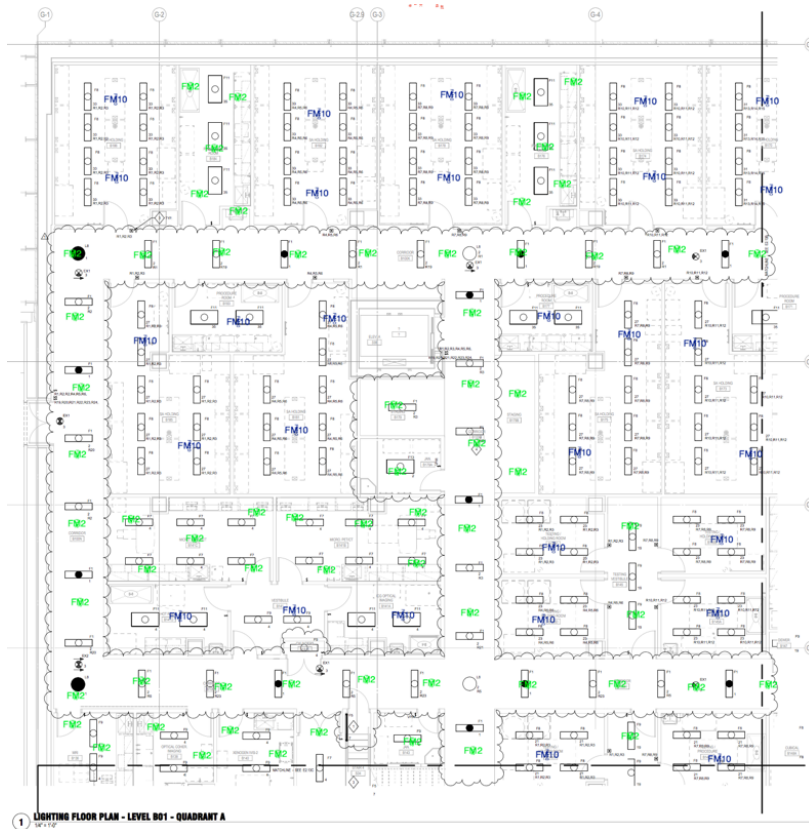

Figure 16: Reflected Ceiling Plan for Temporary Lighting

Lights were anchored to the slab once concrete maturity was met. LEDs were then positioned at the height of overhead construction work, providing upward lighting requirements for workers. Once activities had been completed in the upper elevations of the building, lights were then lowered to provide illumination for trades working closer to floor level.



Figure 17: FM2 and Twist-Lock Connector at ARCF Stairwell

Other lights were simply fastened to interior finishes, like multi-trade racks (MTR) via zip-ties. However, permanent FM10 fixtures in the interstitial maintenance areas were anchored and bolted to the MTR racks (See figure 18).

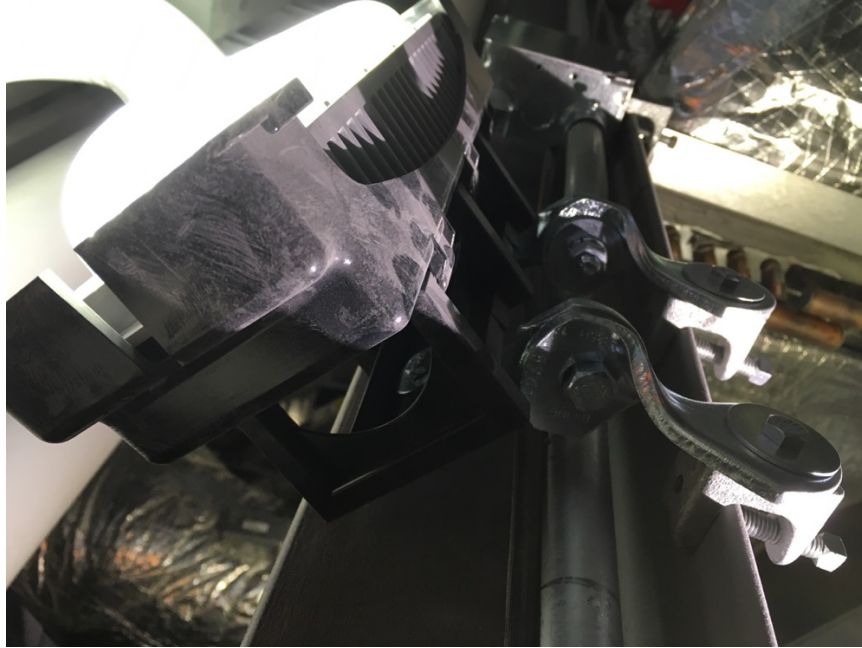

Figure 18: Permanent FM10 in Interstitial Area

Because of security and safety concerns, the complexity of the project, and the need to schedule work activities during off-hours, the temporary lighting system needed to run 24 hours a day, 7 days a week.



Figure 19: FM10 and Twist-Lock Connector in Interstitial Area

Installation Time Frame

Cochran did not have an official construction schedule for the installation and removal of the LED lighting system. However, installation of the Clear-Vu system began after Level B1 precast was finished, and a weekly tracking report of installation work was provided. (See table 14)

Table 14: Weekly Tracking Report of Temporary Light Installation (Source: Cochran)

Week	1st Pass Lbr. (Trimble)	2nd Pass Lbr. (Anchors & Cable)	3rd Pass Lbr. (Controllers & Lights)	4th Pass Lbr. (Lower Lights)	5th Pass Lbr. (Demo)	Total Lbr. To Date
24-Jan	16	32				48
31-Jan	17	39				56
7-Feb	15	47	38			100
14-Feb	16	73	40			129
21-Feb	16	46	44			106
28-Feb	8	28	65			101
6-Mar	2	18	26	4		50
13-Mar	4	23	28			55
20-Mar	18	23	30	8		79
27-Mar	13	32	42			87
3-Apr	12	45	31	12		100
10-Apr	24	67	42			133
17-Apr		40	20	8		68
24-Apr		26	16			42
1-May		16	24	16		56
8-May		24	32			56
15-May			22	10		32
22-May			46	7		53
29-May			12			12
5-Jun			28			28

Modules were installed around the first week of February 2016, and work on the lights continued for 24 weeks. Finally, it was estimated that all temporary lighting would be removed by the end of December 2016.

Clear-Vu's 2015 Estimated Costs and Savings

Early estimated cost of materials and energy expenses provided by Cochran and Clear-Vu's cost-savings calculator for the ARCF project reveal the initial material investment in LED lighting modules would cost \$97,502, whereas the investment in a traditional lighting system would only run \$44,743, creating a pricing difference of \$52,759, as illustrated in table 16.

However, estimated energy usage expenditures for a traditional temporary lighting system would far exceed that of an LED system. At \$.08 a kilowatt hour, 24 hours a day, and across a 12-month period, estimated energy expenses for a traditional lighting system would cost \$35,186.

Under the same conditions, while factoring in Clear-Vu’s 12-hour power dimming capabilities, estimated costs would be \$6,095. Unfortunately, the cost estimate does not factor in ARCF’s FPS450DT power supply, which limits power consumption by 75% during off hours.

Looking at just the cost differences between initial material investment and energy use over 12 months, the time it would take for the LEDs to break even would be 22.2 months, as noted in table 15.

Table 15: 2015 ARCF Clear-Vu Estimated Energy and Materials Cost (Source: Clear-Vu)

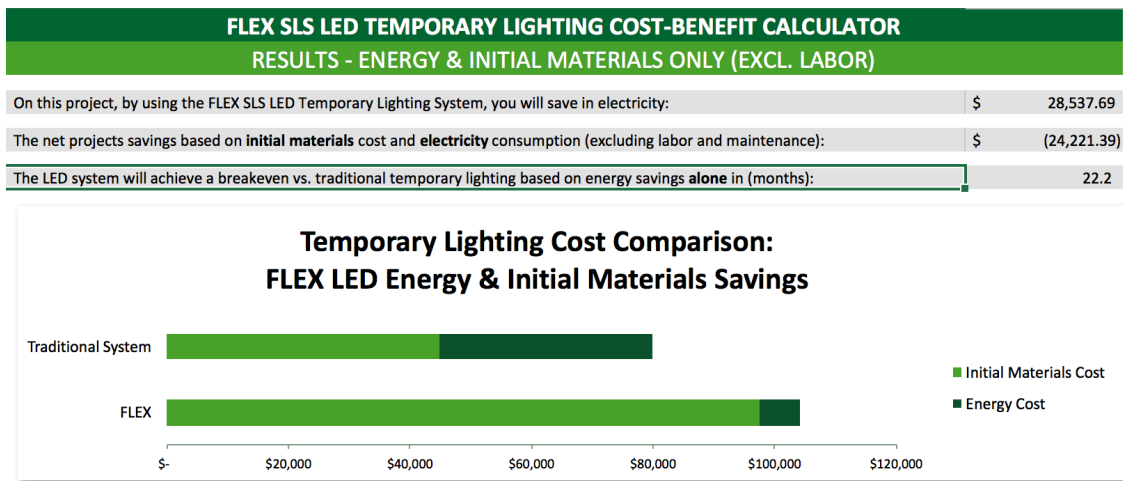

Along with energy and material costs, maintenance rates for LEDs are much lower. Although individual lamps are relatively expensive to replace--\$50 for a Flex 9 watt LED compared to a \$3 compact florescent (CFL), or \$138.60 for a Flex 30 watt LED versus a \$125 250w metal halide, replacement expenditures are much lower for LED systems due to the longevity and durability of the lamps. Resulting labor and material costs for maintenance would only run \$544 for the LEDs compared with \$19,483 for the traditional lighting systems at the ARCF site.

In addition to maintenance cost savings, the longevity of LED systems coupled with the reduction of material and energy waste increases onsite environmental sustainability. Although initially expensive, the energy efficiency and endurance qualities of ARCF’s LED temporary lighting system could potentially pay for itself over the course of 13.3 months, as demonstrated in table 16. Additionally, electrical wiring and hardware used for temp lighting

onsite will be further integrated into the final building design, reducing infrastructure redundancies. Finally, 156 FM10 modules will be integrated into the final building design, further imparting their energy and waste reduction qualities throughout ARCF's lifecycle.

Table 16: Clear-Vu Estimated Energy, Materials & Projected Labor Savings Comparison (Source: Clear-Vu)

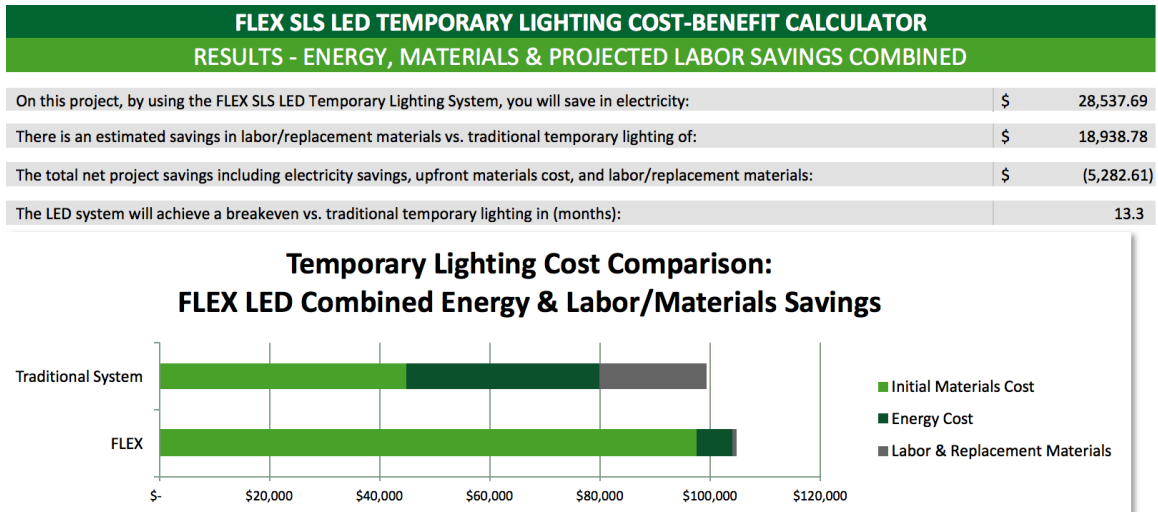

Table 17: Clear-Vu Temporary Lighting Cost/Benefit Breakdown (Source: Clear-Vu)

	FLEX 9W Module	Incandescent/CFL Bulb	FLEX 30W Module	250W Metal Halide
Bulb wattage	7	32	21	285
Total size of project (Sqft)	81,000	81,000	81,000	81,000
% dedicated to Project	65%	65%	35%	35%
Sqft Coverage/bulb	100	100	225	400
# bulb fixtures in project	490	527	322	129
# of PS in project	11		23	
feet of wire in project	4,900		6,440	
Watts/project	3,352	16,848	6,768	36,708
kWatts/project	3.35	16.85	6.77	36.71
Electricity cost (kWh)	\$ 0.08	\$ 0.08	\$ 0.08	\$ 0.08
Electricity cost/day (24hr)	\$ 6.03	\$ 30.33	\$ 12.18	\$ 66.07
Electricity cost/month	\$ 183.50	\$ 922.43	\$ 370.55	\$ 2,009.76
Duration of project (months)	12	12	12	12
Electricity cost/project	\$ 2,202.00	\$ 11,069.14	\$ 4,446.60	\$ 24,117.16
Electricity savings/project	\$ 8,867.13		\$ 19,670.56	
Initial # of bulbs/project	490	527	322	129
Cost for bulb/light fixture	\$ 50.60	\$ 3.00	\$ 138.60	\$ 125.00
Cost for romex/stringer per fixture	\$ 8.40	\$ 7.00	\$ 25.21	\$ 18.00
Cost for power supply per fixture	\$ 10.39		\$ 33.39	
Upfront materials cost per fixture	\$ 69.39	\$ 50.00	\$ 197.20	\$ 143.00
Total upfront materials cost	\$ 34,002.52	\$ 26,325.00	\$ 63,499.96	\$ 18,418.40
Upfront materials cost difference	\$ 7,677.52		\$ 45,081.56	

	FLEX	Traditional System
Initial Materials Cost	\$ 97,502	\$ 44,743
Initial Materials Cost Difference	\$ 52,759	
Labor & Replacement Materials	\$ 544	\$ 19,483
Labor & Replacement Materials Savings	\$ 18,939	
Energy Cost	\$ 6,649	\$ 35,186
Energy Cost Savings	\$ 28,538	
Net Project Benefit	\$ (5,283)	
Energy & Materials Breakeven ROI (months)	22.19	
Labor Breakeven ROI (months)	33.43	
Combined Breakeven ROI (months)	13.34	

Cochran's 2016 Traditional Lighting Cost Estimate

In addition to providing information for Clear-Vu's cost-benefit calculator, Cochran developed their own cost breakdown summary for the installation and maintenance of a traditional temporary lighting system. Using required contract specifications, Cochran's estimate incorporated labor and materials to provide 5 foot-candles of illumination throughout the facility. Cochran's summary for the specified scope of work:

Provide all associated labor and materials to provide 5 foot-candles of fluorescent construction lighting during buildout. Proposal includes 110 HD lights hung from the B01 precast deck for B02 interstitial buildout and 280 CFL lights dropped from the deck for B02 TI buildout. In addition, there are 100 HID lights hung from the roof deck for B01 interstitial buildout and 265 CFL lights dropped from the roof deck for B01 TI buildout. A transformer, (2) 100A dedicated lighting panels with one set of spare lamps included for infrastructure makeup (Cochran. 2016).

Direct craft labor cost, which includes crew (apprentices, journeymen), foreman, and a safety markup, totaled \$219,243. Material costs for the installation came to \$152,053. Not including the 11% contractor fee on self-performed work, total cost of installing and maintaining lights came to \$371,296, which is \$347,913 more than Clear-Vu's 2015 cost-benefit estimate.

Besides differences in cost, Cochran's estimate differs on lamps, including 1,090 100watt CFL, 210 400watt High-Bay lamps, and 210 400watt Metal Halide replacement (maintenance) lights. In comparison, Clear-Vu's cost-benefit calculator estimate only calls out 527 32w CFL, and 285 250watt Metal Halide lamps.

Cochran's LED Lighting Cost

Cochran provided a weekly tracking report, which includes their budgeted cost of materials and labor for the installation and removal of the Clear-Vu system. Quoted material for the LED system totaled \$100,325, while the general labor to install was \$201,788. Table 18 is a budget analysis provided by Cochran.

Table 18: Weekly Tracking Report Budget Analysis (Source: Cochran)

Cochran Budget Analysis	
LED Quoted Material	\$100,325
General Material	\$50,039
Install/Maintain/Removal (65.98/hr)	\$201,788
CAD Labor (81.65/hr)	\$12,084
Safety/Misc. Cost	\$7,684
Total Cost	\$371,920

Energy Use Costs

On July 20th, 2016, UW Facilities Maintenance & Construction installed a Dent ELITEpro XC Energy Logger to monitor and collect data on energy usage of the temporary lighting system in ARCF. After 21 days of monitoring, the logger was removed on August 9th, 2016.



Figure 20: Installed Energy Logger at ARCF (Source: Smith. 2016)

Table 19 is a graph of temporary lighting energy use across the 3-phase power system. The analysis summary of the data outlines the average kilowatt (KW) per each phase, which can be summed to give an average kilowatt hour (kWh). Total kWh for the indoor temporary lighting was 8.82 kWh.

Table 19: Measured Energy Use

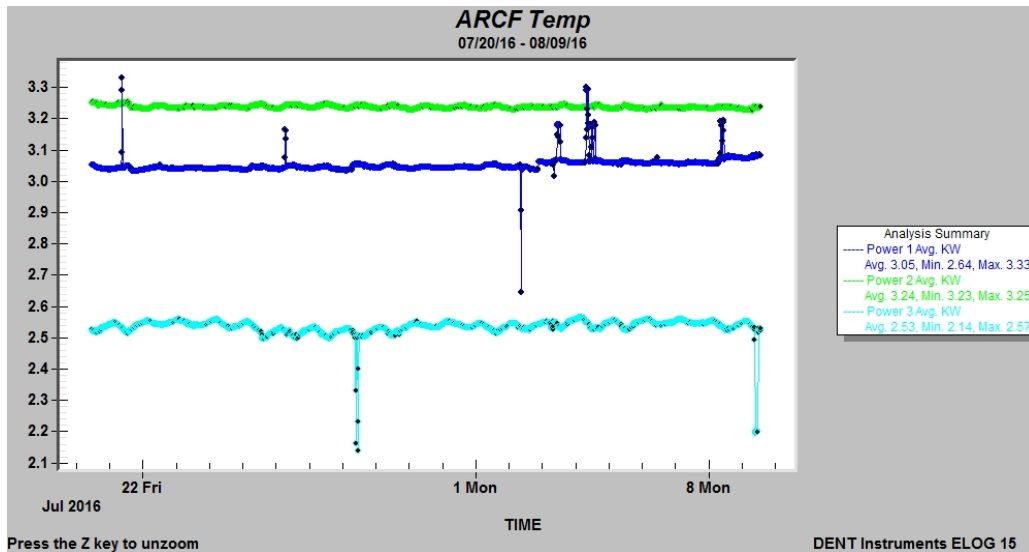

With average kWh in hand, an estimate of yearly energy costs can easily be calculated. Table 20 compares Cochran’s energy use based on their traditional lighting schedule and ARCF’s actual LED energy cost.

Table 20: Estimated Energy Cost

Item	Estimated:	Estimated:	Actual:	Actual:
	HID	CFL	FM2	FM10
# of Modules	210	1090	490	322
Wattage per Fixture	456W	32W	10W	30W
Average kWh	95.76 kWh	34.88 kWh	8.82kWh	
Cost per kWh	\$.08	\$.08	\$.08	
Cost per Day	\$184	\$67	\$16.93	
Cost per Year	\$67,109	\$24,444	\$6,181	
Total Annual	\$91,553		\$6,181	

The total annual difference/cost savings between Cochran’s traditional lighting plan and the installed LED lighting system is \$84,728. Furthermore, the cost-benefit analysis provided by Clear-Vu is starkly different, at a \$18,939 disparity in favor of the traditional lighting system (see table 16).

Table 21: Cochran Cost Comparison

Lighting Cost-Benefit Table	
Based on Energy and Primary Hardware Costs of LED vs. Traditional lighting	
Over the course of 12 months, this project will save in electricity:	\$85,352
Estimated savings in installation costs:	\$-2,313
Cost difference based on material, install, and electricity costs:	\$84,728

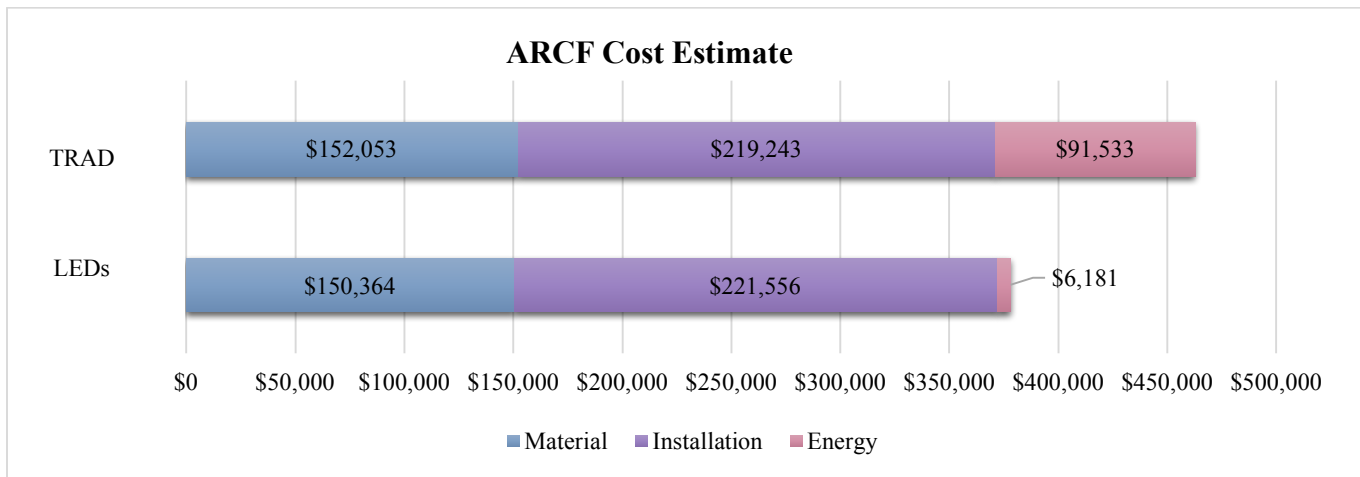

Figure 21: ARCF Cost Estimate Comparison

Comparing Cochran’s two budgets, the LED system cost \$2,313 more to install; however, energy cost disparities between the two systems yields an annual savings of \$85,352 in favor of LEDs.

Looking back at the historical cost differences between Clear-Vu and traditional lighting systems, LEDs usually have a higher material and installation cost. When asked about the small cost disparity between the two systems at ARCF, Cochran noted the relative complexity and uniqueness of the project, which elevated both costs (Harrell. 2016).

Cost Differences Between Traditional Lighting

Cochran’s material estimate for a traditional lighting system at ARCF does not have a direct 1-to-1 luminance comparison between the two lighting systems. Furthermore, Clear-Vu’s FM2 was design to directly replace a 20w compact fluorescent, and the FM10 is a substitute for a 100w metal halide. To paint a more accurate picture of energy use between a tradition system and

ARCF LEDs, comparable lamps based upon light output have been substituted in the following energy estimate as seen below in table 22.

Table 22: Comparable System Lighting Estimates

Item	Estimated: 20W CFL	Estimated: 100W MH	Actual: FM2	Actual: FM10
# of Modules	490	322	490	322
Wattage per Fixture	23W	120W	10W	30W
Average kWh	11.27 kWh	38.64 kWh	8.82kWh	
Cost per kWh	\$.08	\$.08	\$.08	
Cost per Day	\$22	\$74	\$16.93	
Cost per Year	\$7,898	\$27,079	\$6,181	
Total Annual	\$34,977		\$6,181	

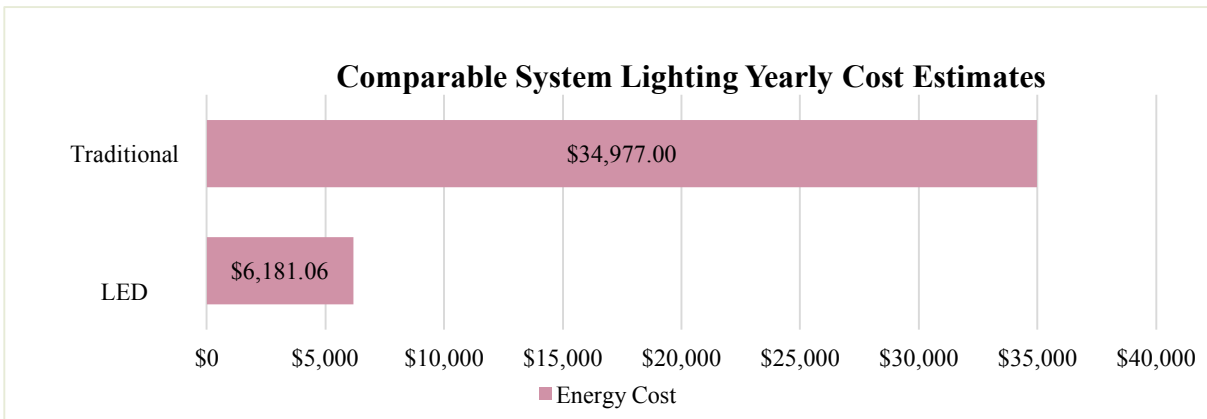

Figure 22: Comparable System Lighting Cost Estimates

Evaluating Cochran’s traditional temporary lighting schedule to the new comparable lighting estimates, there is a \$56,556 difference in yearly expenses. Additionally, over the course of one year, Clear-Vu’s LEDs still saves \$28,796 and 359,948 kWh over the comparable traditional lamps.

Other Temporary Lighting Used Onsite

Prior to the completion of the FLEX lighting system at ARCF, RAB FXLED300T LED flood lights were implemented during early phases of temporary light installation. The temporary

floods, as seen in figure 24, were placed around site and on columns to provide adequate lighting for workers during the assembly and installation of the FLEX SLS system.

FXLED300Ts are currently being used for outdoor security. To limit afterhours light pollution, three flood lights at the north end of ARCF are on a timer, turning off at 7pm and restarted at 4am. FXLED300T flood lights on the south side are timed to provide evening illumination, turning on at 7pm and shutting off around 4am.

In addition to the FXLED300Ts floodlights, Tiger 400 HID lights, seen in figure 25, were used for general illumination prior to the installation of the FLEX LED system. The Tiger 400 HID is a 400watt, type-0 metal halide lamp, and were chosen as a temporary light source due to being a cost efficient temporary solution.



Ultra high output, high efficiency LED floodlight with NEMA Types: 7H x 6V, 6H x 4V, 4H x 6V, 5H x 5V and 3H x 3V. Patent Pending airflow technology ensures long LED and driver lifespan. Use for general and security lighting for large areas, building facades, signs and landscapes.

Color: Bronze

Weight: 66.1 lbs

Figure 23: RAB FXLED300T LED

FXLED300Ts were used for outdoor security. To limit afterhours light pollution, three flood lights at the north end of ARCF are on a timer, turning off at 7pm and restarted at 4am. FXLED300T flood lights on the south side are timed to provide evening illumination, turning on at 7pm and shutting off around 4am.



Figure 24: Tiger 400 HID MH

Survey of Trades

With the help of Skanska’s Environmental Safety and Health Manager, Chiung-I Hwang, workers were randomly chosen from a list of 153 workers involved with the construction of ARCF. Individuals were selected randomly within trades to get a larger scope of opinions across all stakeholders. For larger subcontractors, more participants were selected to account for their size.

18 survey responses were received over the course of a one-month period. Surveys were numbered from 1 through 18 with responses being entered and coded into an Excel spreadsheet.

A cursory look at Survey Question 11 reveals that most of the workers on site had a positive experience working with ARCF’s temporary LED lighting system while workers’ experiences with traditional sources were less positive.

Each category on question 11 is rated on a 5-point scale: 1 bad, 2 poor, 3 fair, 4 good, and 5 excellent. Ratings for LEDs ranged from 4.11 to 4.44. On the other hand, workers’ previous experience with traditional lighting was slightly less positive, with scores ranging between 2.82 to 3.44. (See table 23)

Table 23: Average Rating of Positive Lighting Attributes

Description	Average rating	
	LED	TRAD
Amount of Light Provided	4.22	3.18
Consistent and well distributed	4.17	2.82
Productive	4.11	3.44
Visually comfortable	4.22	3.06
Safe operation of work	4.44	3.41

Scores for negative attributes of the LED lighting system were also collected in the survey, which can be seen in table 23. Workers could rate their experiences on a scale from 1 to 5, where 1 disagree, 2 somewhat disagree, 3 neutral, 4 somewhat agree, and 5 agree.

Average negative ratings for the LED system were lower than that of traditional lighting, ranging between 1.78 and 2.28, whereas traditional lighting had a score ranging from 2.41 to 2.94. (See table 24)

Table 24: Average Rating of Negative Attributes

Description	Average rating	
	LED	TRAD
Distracted from work	1.78	2.41
More disruption	1.83	2.94
More coordinated efforts	2.28	2.76

To understand workers' opinions and experiences regarding the temporary LED lighting at ARCF, Weka, a data mining program, was used to combine different variables and identifiable factors. Furthermore, to input workers' responses into the data mining program, answers were recoded to a "True or False" format. For instance, if a worker checked that they had been working in a staircase, that answer was coded as "TRUE." If they had not been working in the staircase, the answer would have been marked as "FALSE."

Next, workers' experiences with the two systems were subsequently compared to better understand which they preferred. The inquiries from question number 11 were reworded into contrasting statements between LED and TRAD systems, such as—

- LED provides more lighting than TRAD
- LED provides more consistent and well distributed lighting than TRAD
- I feel more productive with LED lighting than TRAD lighting
- LED lighting is more visually comfortable than TRAD lighting
- LED lighting made my work more operationally safer
- LED distracted me from working properly more than TRAD
- LED disrupted my work more than TRAD
- LED required more coordination than TRAD

Following the language adjustment, the original ratings were compared with one another; for example, a higher numeric rating for LED lighting than traditional lighting would convert the data to TRUE, where as a numerically equal comparison between systems would change the data to NEUTRAL and a smaller rating would be recoded as FALSE. For example, if the “Amount of light provided” by traditional lighting was 3, and the “Amount of light provided” for LEDs was 5, then the resulting answer would be recoded as TRUE.

After the data was recoded, Weka was used to sort each response by trade and worker's experience with the different lighting systems. The following tables demonstrate workers' experience and preference of lighting based on construction trade.

Table 25: ARCF Trades with Color Legend

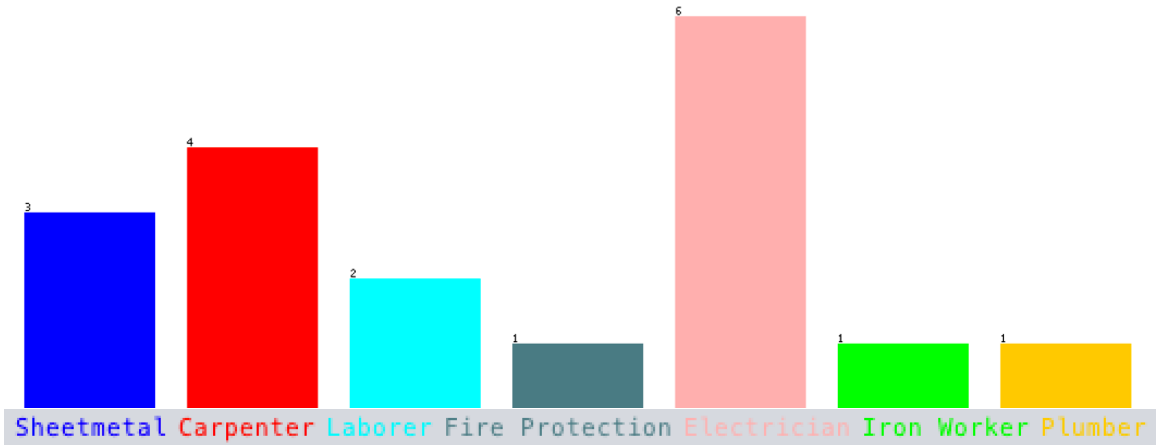
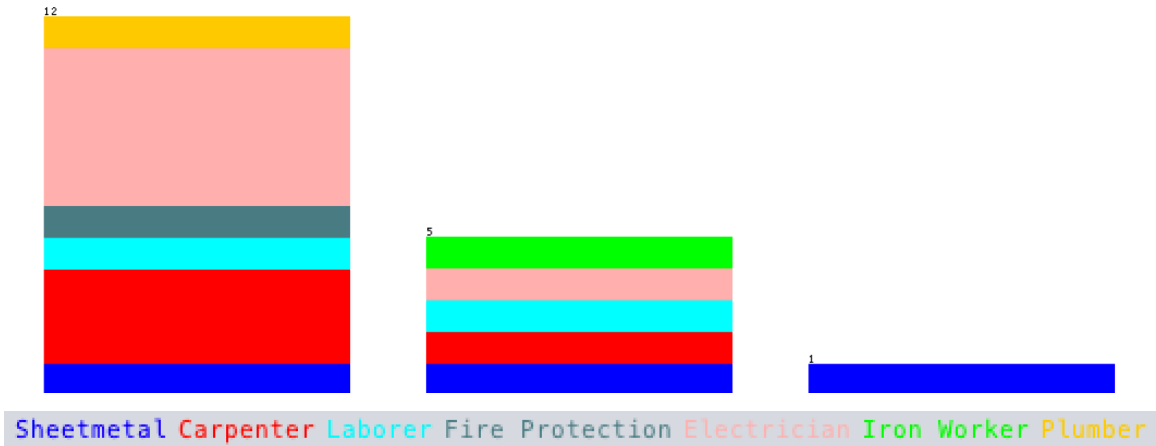

Table 25: ARCF trades surveyed include: three sheet metal, four carpenters, two laborers, one fire protection, six electricians, one iron worker, and one plumber.

Table 26: LED Provides More Lighting Than TRAD

(True, Neutral, False)



In table 26, only one worker—a sheet metal subcontractor—responded that they felt LED lighting does not provide more lighting than traditional lighting.

*Table 27: LED Provides More Consistent and Well Distributed Lighting Than TRAD
(True, Neutral)*

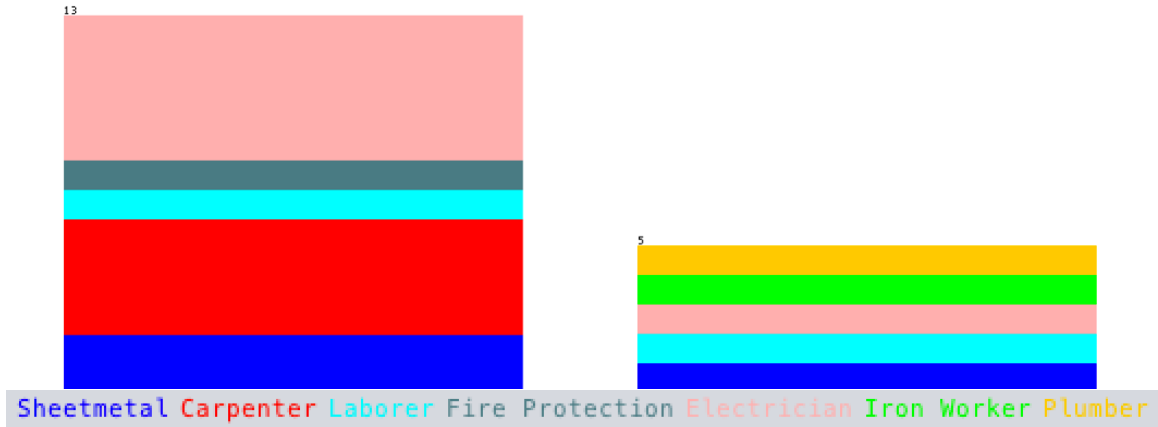

Table 27: Thirteen workers responded “true” towards LED provides more consistent and well distributed lighting than traditional lighting. Five workers responded neutrally.

*Table 28: I Feel More Productive with LED Than with TRAD
(True, Neutral)*

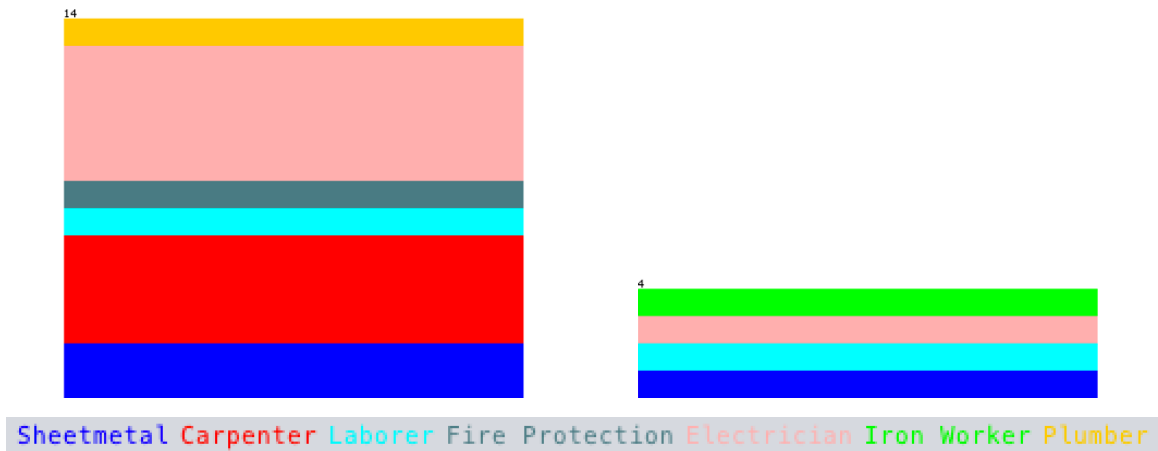

Table 28: Fourteen respondents felt that they were more productive with LED rather than with traditional lighting. Four respondents marked neutral.

Table 29: LED Is More Visually Comfortable Than TRAD

(True, Neutral, False)

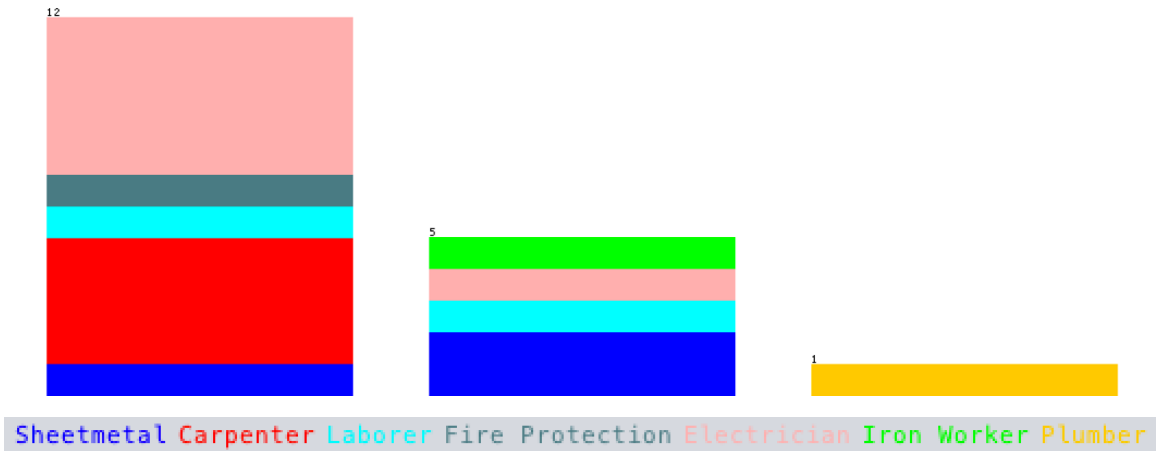

Table 29: Twelve respondents marked they felt that LED is more visually comfortable than traditional lighting. However, one plumber reported false, that LED is not more visually comfortable than traditional lighting. Fiver respondents marked neutral.

Table 30: LED Lighting Made My Work More Operationally Safer

(True, Neutral)

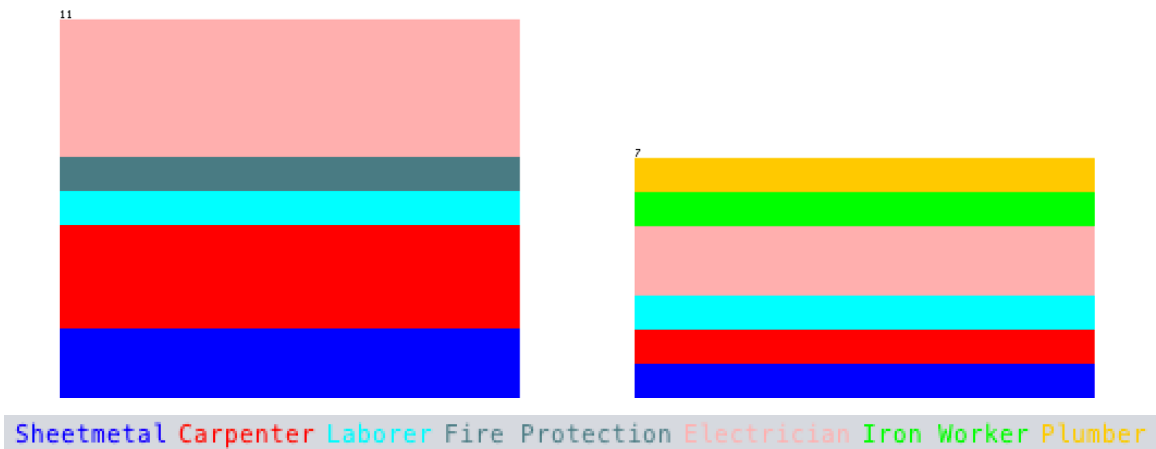

Table 30: Eleven respondents marked that they felt LED lighting made their work safer. Seven other respondents marked neutral.

Table 31: LEDs Distracted Me from Working Properly More Than TRAD

(True, Neutral, False)

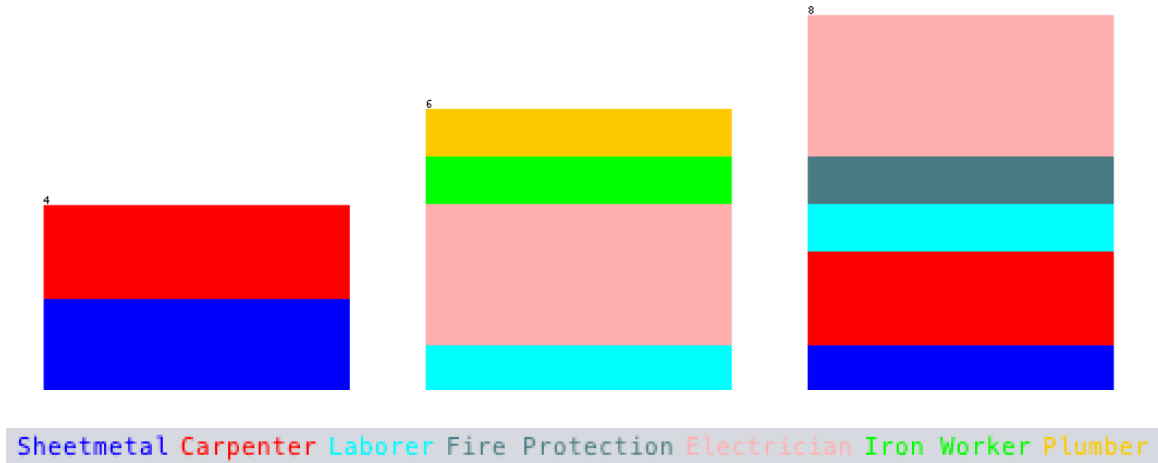

Table 31: Four workers responded that the LEDs were distracting them from working properly, while six were neutral, and eight noted that that statement was false for them.

Table 32: LED Disrupted My Work More Than TRAD

(True, Neutral, False)



Table 32: Two carpenters felt that the LEDs disrupted their work more than traditional lighting. Nine individuals were neutral, while seven found that statement to be false.

Table 33: LED Required More Coordination Efforts Than TRAD
(True, Neutral, False)

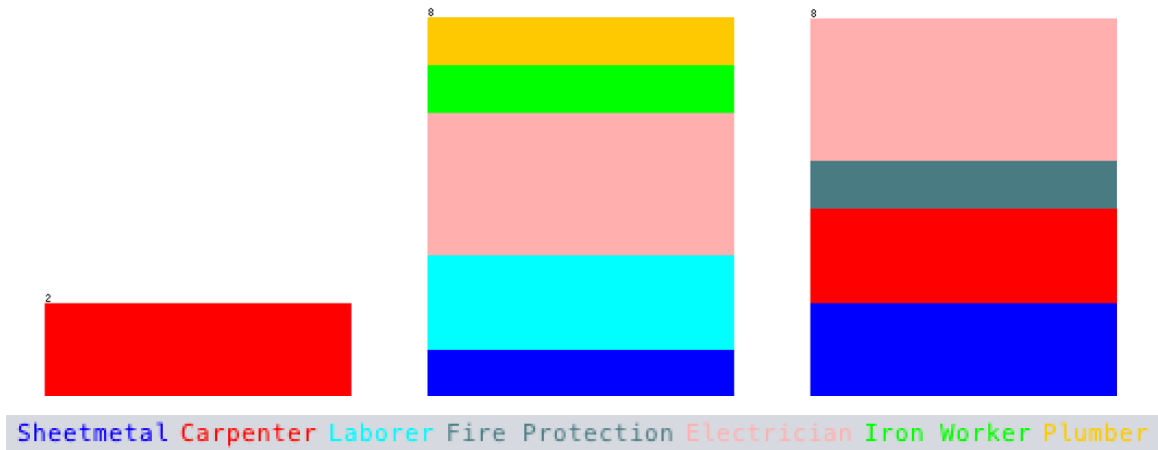

Table 33: Two carpenters felt that the LEDs required more coordination efforts than traditional lighting. Eight workers were neutral, and another eight noted that they did not believe that LEDs required more coordination.

Looking through the graphs generated by Weka, only the carpenters uniformly agreed positively on three of the eight questions.

- I Feel More Productive with LED than with TRAD
- LED is More Visually Comfortable than TRAD
- LED Provides More Consistent and Well Distributed Lighting than TRAD

On the other hand, most of the trades responded either positively or neutrally about their working experiences with Clear-Vu’s LED lighting system at ARCF. However, in addition to agreeing positively to three of the eight questions, the carpenters were also the only trade with the most uniform negative answers, responding to two out of the eight questions disapprovingly.

- LED Disrupted My Work More than TRAD
- LED Required More Coordination Efforts than TRAD

Sheet metal workers also had mixed negative reviews of the LED lighting system, with one out of three answering negatively to “LED Provides More Lighting than TRAD”, and two out of three responding that LEDs distracted them more from working properly than TRAD.

Regarding qualitative responses on the survey: response #1, a sheet metal worker, stated that the LEDs “*shine directly into eyes and have to constantly block light to see what’s happening.*” Furthermore, response #8, another sheet metal worker, noted that “*the temporary lighting was fine below eight feet*”, and that it is “*time to search out other lighting options.*”

Despite the negative feedback, most wrote that they found working with the new temp lighting to be helpful or easy. Response #2, a carpenter with forty years of experience, stated that the LEDs were the “*best temp lighting on a jobsite that I’ve seen.*” Response #11, an electrician, wrote LED temp lighting was “*more helpful*”, and the “*fixtures are easy to install, easy to relocate if in the way, very light weight.*”

Other Qualitative Findings

Mobility of the new LEDs were mentioned by three of the respondents, all in a positive way. One sheet metal worker noted, “*to push them out of the way for work access is much easier than the heavy, sodium bulb, and safer.*” The same worker also stated, “*more helpful when needed to be moved or worked around, the operation conditions are much cooler than sodium lights. LEDs are lighter and safer and much more durable.*”

Brightness and intensity of light were referenced in three of the surveys, with two writing negatively about the high levels of illumination being projected by the lights. One worker wrote, “*...the intensity can make it difficult if looking in the direction of.*”

Combined Surveys

The survey administered to ARCF workers was the same as the previous case study’s, making it possible to combine data for a larger picture of workers’ opinion on temporary construction lighting. However, to create a more concise voice of workers’ opinions, trades with only single

respondents were eliminated from the data. Fire Protection, Iron Worker, Painter, Mechanical Insulator, and Acoustic Ceiling Tile were removed from the combined data.

Again, each category on table 34 is rated on a 5-point scale: 1 bad, 2 poor, 3 fair, 4 good, and 5 excellent. Combined average ratings for LEDs ranged from 4 to 4.27, a decrease from ARCF’s 4.11 to 4.44 score. On the other hand, workers’ previous experience with traditional lighting was less positive, with scores ranging between 2.63 to 3.35, a decrease from ARCF’s 2.82 to 3.44 score. (See table 34)

Table 34: Combined Average Rating of Positive Lighting Attributes

Description	Average rating	
	LED	TRAD
Amount of Light Provided	4.00	2.97
Consistent and well distributed	3.86	2.63
Productive	4.00	3.27
Visually comfortable	4.11	2.97
Safe operation of work	4.27	3.35

Scores for negative attributes of the LED lighting system were also combined, which can be seen in table 35. Again, workers rated their experiences on a scale from 1 to 5, where 1 disagree, 2 somewhat disagree, 3 neutral, 4 somewhat agree, and 5 agree.

Combined average negative ratings for the LED system were lower than that of traditional lighting, ranging between 1.91 and 2.14, a decrease from ARCF’s 1.78 to 2.28 score. Traditional lighting had scores ranging from 2.75 to 2.97, another decrease from ARCF’s range of 2.82 to 3.44.

Table 35: Combined Average Rating of Negative Attributes

Description	Average rating	
	LED	TRAD
Distracted from work	1.97	2.75
More disruption	1.91	2.97
More coordinated efforts	2.14	2.90

Table 36: Combined Survey Trades with Color Legend

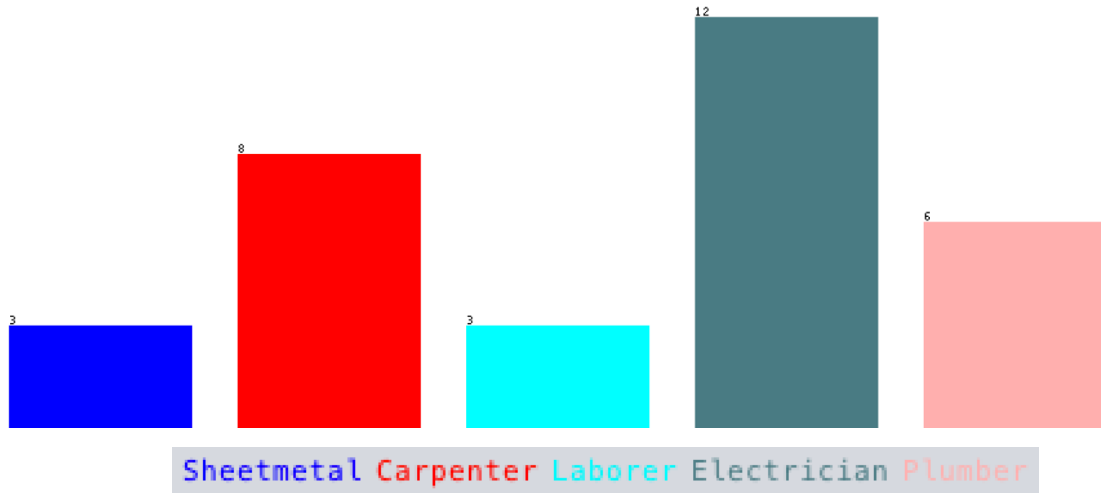

Table 36: Combined survey samples from ARCF and UW Bothell surveys include: 3 sheet metal workers, 8 carpenters 3 laborers, 12 electricians, and 6 plumbers.

Table 37: LED Provides More Lighting Than TRAD
(True, Neutral, False)

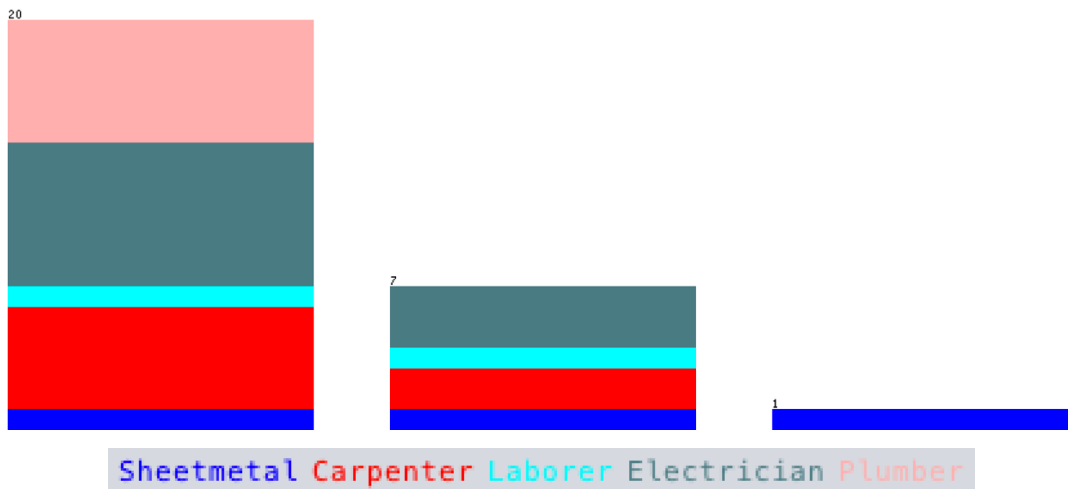

Table 37: Twenty workers reported that LEDs provide more lighting than traditional lights, while seven workers were neutral, and one worker reported “false.”

*Table 38: LED Provides More Consistent and Well Distributed Lighting Than TRAD
(True, Neutral, False)*

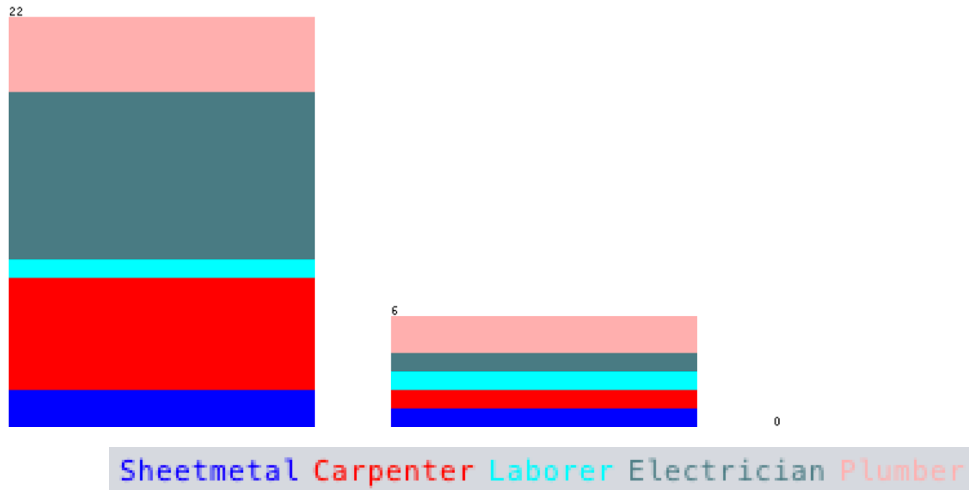

Table 38: Twenty-two workers reported that they felt LEDs provide more consistent, well distributed light over traditional lights. The remaining six workers marked neutral.

*Table 39: I Feel More Productive with LED Than with TRAD
(True, Neutral, False)*

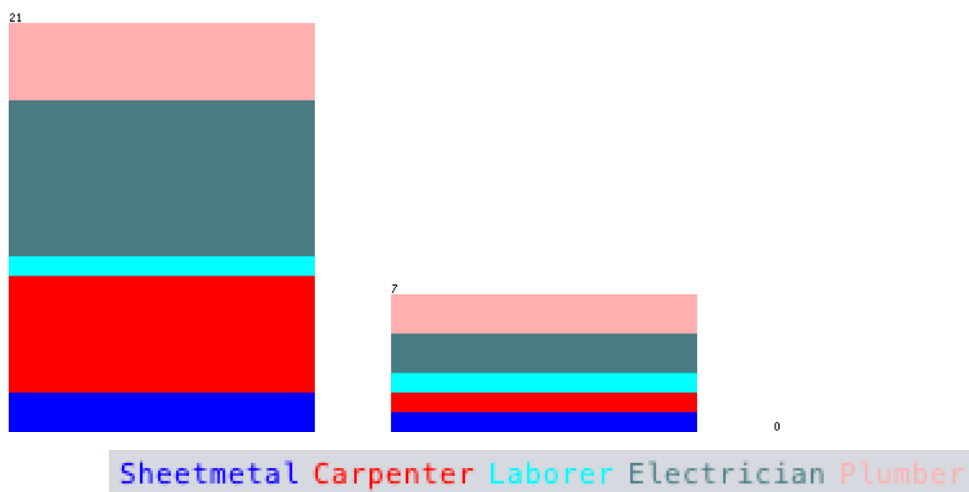

Table 39: Twenty-one workers reported that they felt more productive with LED lights, while the remaining seven workers reported neutral.

Table 40: LED Is More Visually Comfortable Than TRAD

(True, Neutral, False)

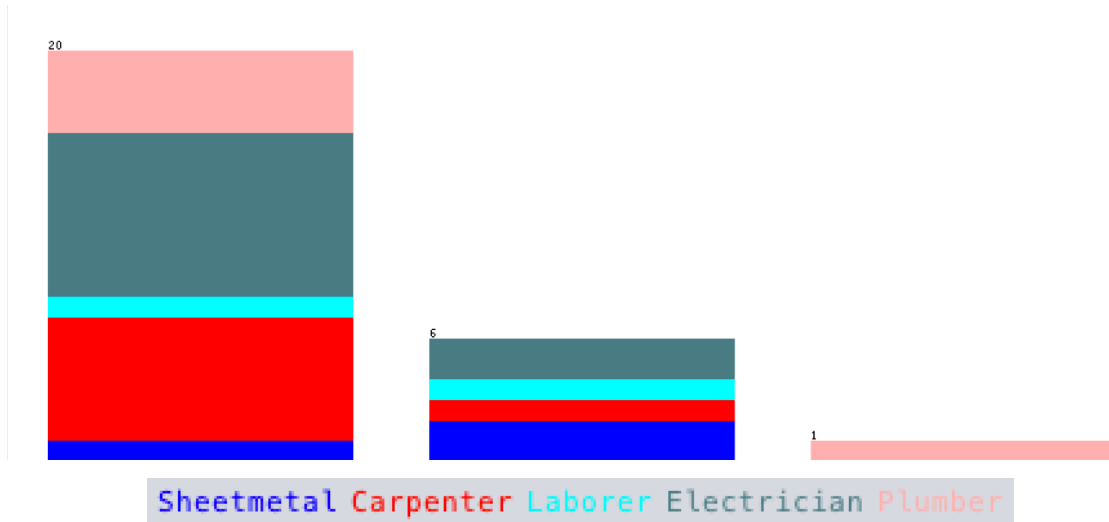

Table 40: Twenty workers reported that LEDs are more visually comfortable than traditional lighting systems, six workers marked neutral, and one worker felt that the LEDs were not more visually comfortable.

Table 41: LED Lighting Made My Work More Operationally Safer

(True, Neutral, False)

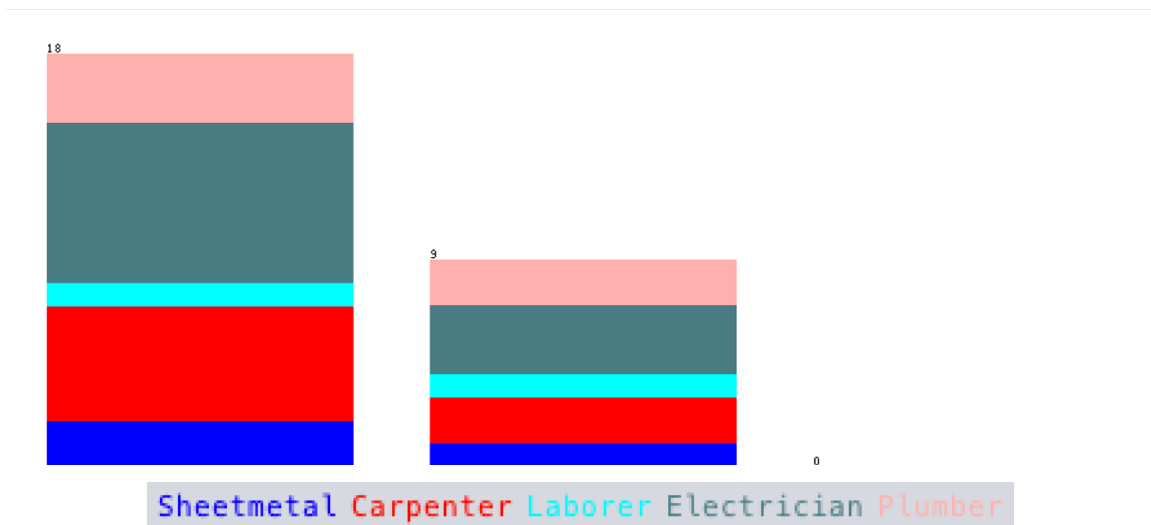

Table 41: Eighteen workers agreed that LED lighting made work more operationally safer, while nine workers were neutral.

Table 42: LEDs Distracted Me from Working Properly More Than TRAD
(True, Neutral, False)

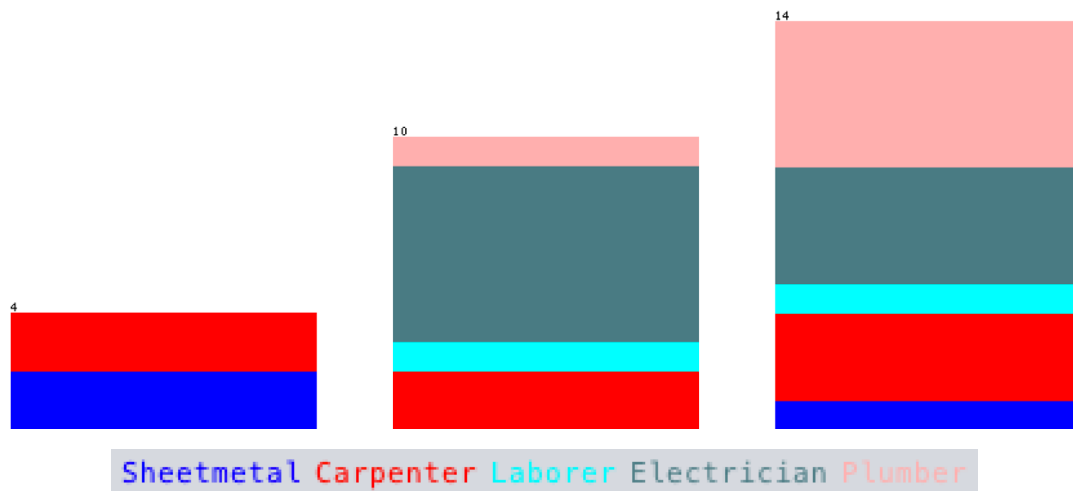

Table 42: Fourteen workers reported that they did not believe LEDs distracted them from working properly more than traditional lighting, where ten workers were neutral, and four workers stated “true.”

Table 43: Table 43: LED Disrupted My Work More Than TRAD
(True, Neutral, False)

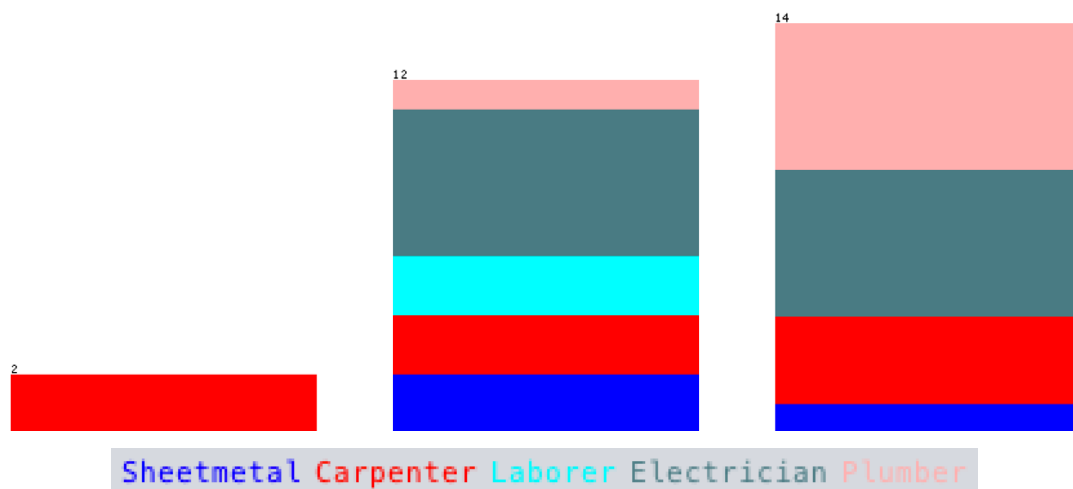

Table 43: Fourteen workers reported that they did not believe LEDs disrupted their work more than traditional lighting, where twelve workers were neutral, and two workers stated that LEDs were more disruptive.

Table 44: LED Required More Coordination Efforts Than TRAD
(True, Neutral, False)

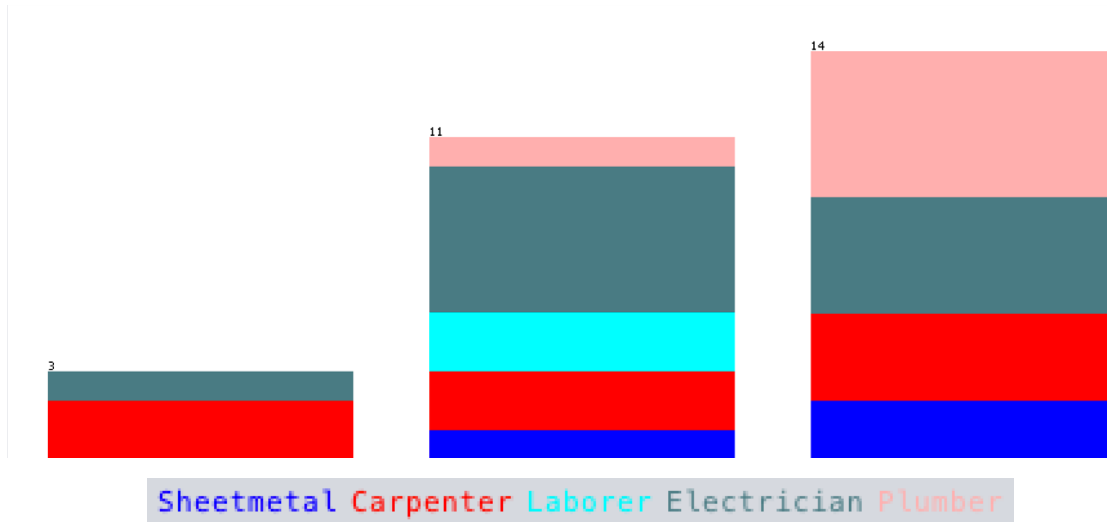

Table 44: Fourteen workers reported that LEDs do not require more coordination efforts than traditional lighting systems. Eleven workers had neutral opinions, and three workers stated that LEDs did require more coordination than traditional lighting systems.

Chapter 4 Summary

The ARCF study, written by the author, reaffirmed the findings from the first UW developed report. Although initially expensive to invest in, LEDs managed to save the project around \$29,000 in energy and maintenance costs. UW’s LEDs will create further value because of their longevity, and reuse from project to project. An SCL material and energy rebate, which is discussed in Chapter 7, also provides some limited value, but is primarily meant to expand adoption across the industry.

Regarding ARCF’s survey, most workers had either a positive or neutral outlook on the lights, yet a small number of carpenters and metal workers had mixed or negative opinions about the system. Workers who responded to the write-in section wrote overwhelmingly of the safety benefits working under the new system provided. However, like the first survey conducted by Yi Jie Huang, workers also complained about glare from the lighting system.

Analysis of the combined survey material reaffirms findings from the ARCF study, and shows that most workers had neutral or positive feelings about the LED lights. However, only the Laborers uniformly responded with positive or neutral experiences, all other trades had at least one negative impression. As mentioned above, combined write-in answers referenced distracting levels of glare for the workers. In response to this issue, the author initiated an investigation into LED glare.

Chapter 5.

ARCF Lighting Survey

Methodology

Foot-candle measurements were taken in accessible areas on level B02, quadrants B and D during the months of July and August. These months were ideal due to the framing and wall finishing activities within the building during this period. In addition to the construction activities, without the completion of framed areas it would have been difficult to way-find and accurately orientate in the building using plan view construction documents. Furthermore, during these months there were five different observable activities in B02: 16-gauge steel framing, insulation, MEP wall rough-in, gypsum wallboard (GWB), and wall finishing/painting. Lastly, meter readings were taken before work started in the early morning hours to avoid disruption of construction activities and for safety.

Areas in quadrants B and D were broken down by rooms and corridors, including the interstitial corridor above. Using construction documents provided by architecture firm ZGF and Skanska, square foot measurements were taken of each room and corridor. Furthermore, reflected ceiling plans of the lighting systems provided by Clear-Vu and Cochran were used to make comparisons between construction documents and the actual install and implementation.

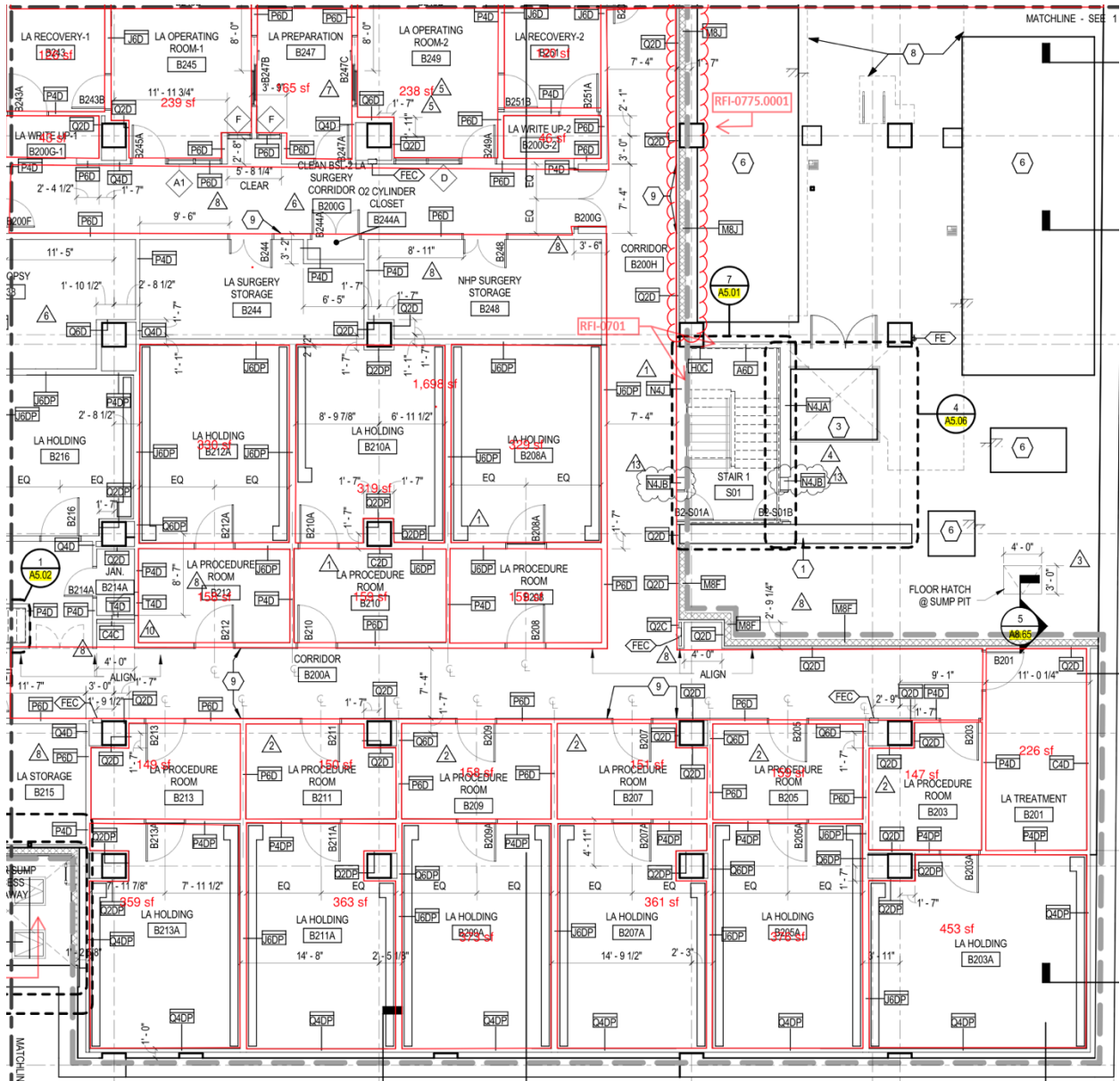

Figure 26: B02 Quadrant D

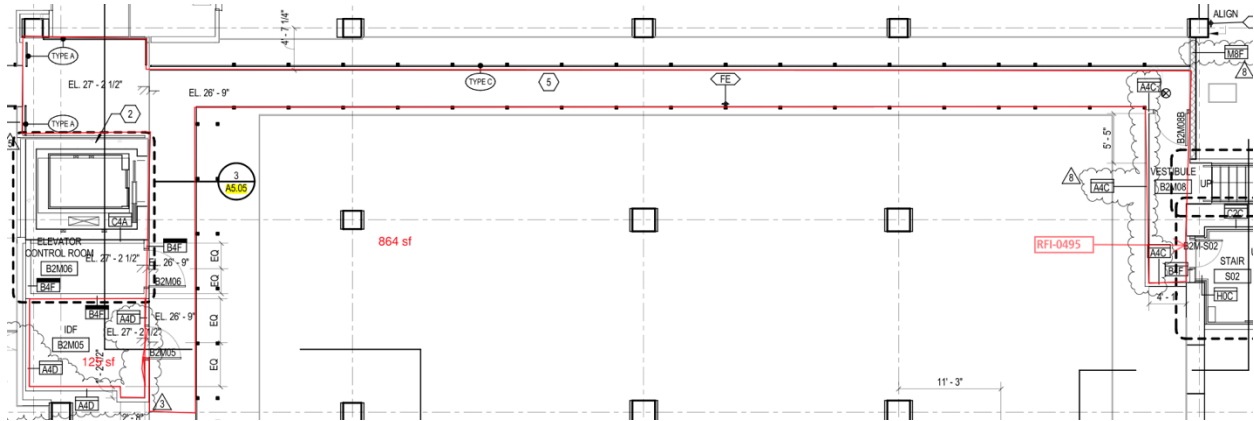

Figure 27: B02 Partial Interstitial Area Over Quadrant B

In accordance with the WAC Minimum Acceptable Average Lighting Level code (see table 5) and Federal guidelines for adequate workplace illumination, foot-candle measurements were taken 30 inches above floor level using a 755B Manfrotto Large Camera Tripod with a mounted Digi-Sense 20250-00 light level meter.



Figure 28: Light Meter Set Up

Although foot-candle measurements were done 30 inches above floor level, many of the construction activities were taking place at or near floor elevation. For instance, all the chop saws used for cutting steel framing material were placed and operated on the floor. (See figure 29)



Figure 29: Meter Reading Near Chop Saw Work Station

Using a tape measure, meter readings were taken in the center of corridors at 5-foot intervals where possible. Rooms were broken into thirds and had three measurements taken.

Methodology Limitations

Because the environment was an active construction site with critical assemblies and finishes being installed, rooms and corridors were used as material and tool storage, some areas were not constructed, or were blocked with important safety systems, such as ventilation fans and plastic screens. This made it difficult to accurately place the light meter. Furthermore, meter readings and measurements had to be done carefully to avoid damaging the building or disturbing the working trades. Meter readings that posed a safety risk to the operator, or had a potential to damage or affect the work on the building, were avoided.

Light Meter Findings and Observations

Average foot-candle (FC) levels on level B02, Quadrants B and D were above the required Federal level of 5 FC, with a mean measurement of 9.49 FC. (See table 45) Average FC in rooms were also well above the required illumination rate, with a mean of 12.27 FC. Furthermore, the highest meter reading of 33.5 FC was taken in room B287. (See table 46)

Table 45: Foot-candle Lighting Measurements

	Square Foot	Mean FC	Median FC	Mode FC
Total	13,958	9.49	7.3	3.3
B02 Quadrants B/D Rooms	9,726	12.27	9.45	8.3
B02 Quadrants B/D Corridors	4,232	6.10	5.5	3.3
B02 Partial Interstitial Corridor	864	9.12	8.3	-
B02 Corridor Quadrant B	1,698	4.79	4.5	3.6
B02 Corridor Quadrant D	1,670	6.79	6.9	3.3

When comparing foot-candle measurements to ANSI recommended lighting recommendations (see table 6), 43 out of 43 of the areas measured averaged above category A, 41 out 43 averaged above category B, 22 out of 43 averaged above category C, and 3 out of 43 areas averaged above category D.

However, there were a few areas that were either heavily shadowed or not adequately lit. For instance, average measurements in Quadrant B’s corridors were 4.79 FC, followed by a mode of 3.3 FC. In addition to Quadrant B’s measurements, the lowest reading of 0.5 FC was taken in Corridor Quadrant D. (See table 45)

Table 46: Foot-Candle Range

	Minimum FC	Maximum FC
Range	0.5	33.5
Location	Corridor Quadrant D	NHP ROOM B287

Upon further comparison of these low foot-candle readings with on-site conditions, inadequate illumination was caused by two factors: obstruction by subcontractors' materials and tools, and insufficient maintenance of lights. For instance, a subcontractor's tool box was in Corridor D, which cast deep shadows along the corridor. Furthermore, in that same area, lights were not properly repositioned around the steel framing—LEDs were not in the center of the corridor, and were too high above the framing. (See figures 30 and 31)



Figure 30: Lights High Above Framing and Shadows Cast by Tool Box

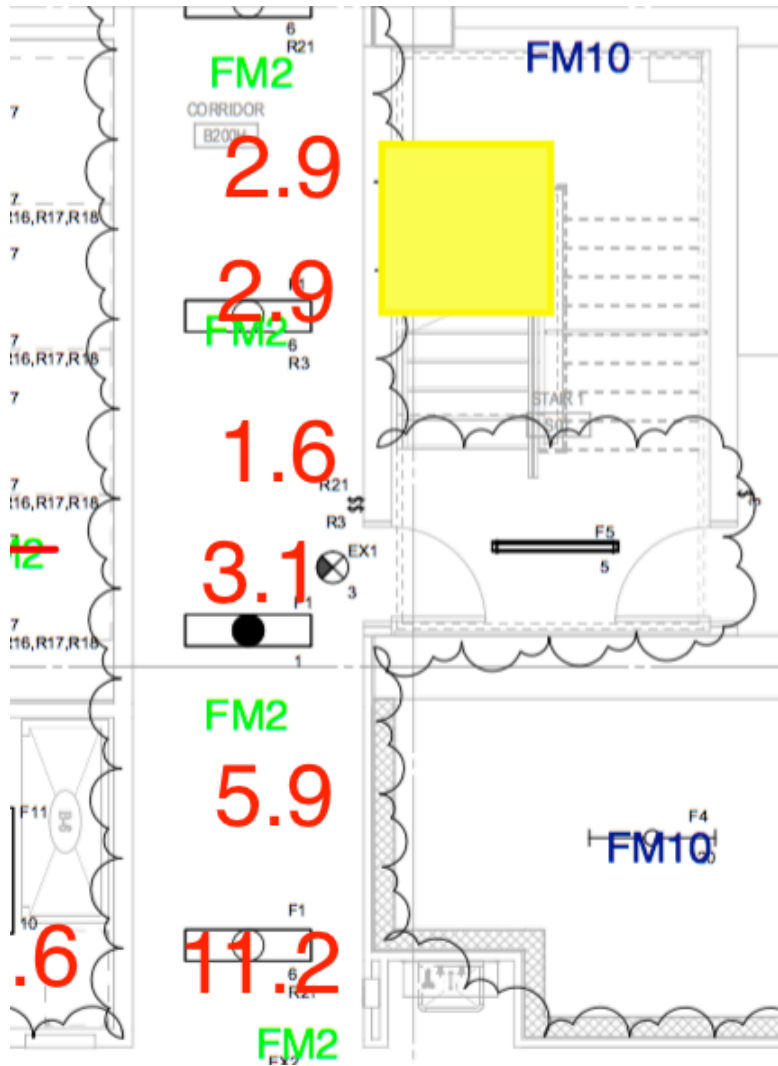

Figure 31: Foot-candle Measurement Notes From Area in Figure 20

More instances where meter readings were below required illumination levels can also be attributed to the above factors, like lights being too high above the steel framing, lights positioned at inefficient angles, or lights completely blocked by framing or wall insulation.



Figure 32: Corridor D: FM2 Blocked by Steel Framing



Figure 33: FM2 in Interstitial B02 Blocked by Insulation

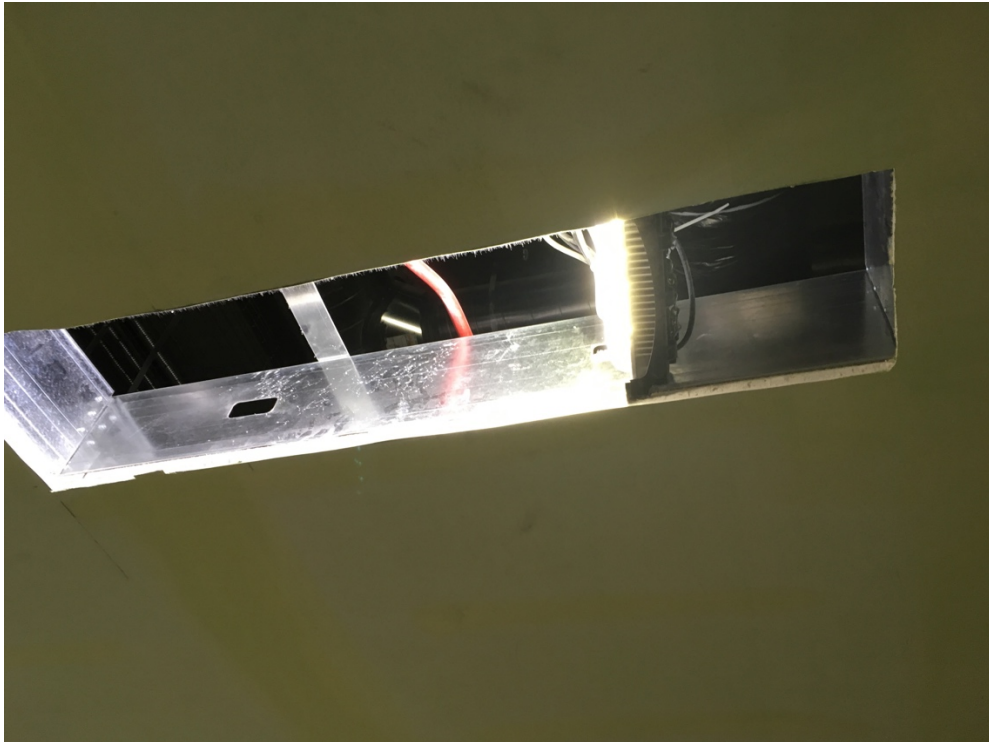

Figure 34: FM10 Tipped Over

Other Observations

Comparing the two construction documents provided by Cochran and Clear-Vu with actual site conditions, there were variations with how the Clear-Vu LEDs were installed. For instance, looking at NHP Treatment Room B284, both Cochran's and LED lighting layout called for four FM2 lights. (See figures 35 and 36) However, actual observed conditions noted that there were only two FM2 lights installed in B284. (See figure 37) This issue was seen throughout level B02.

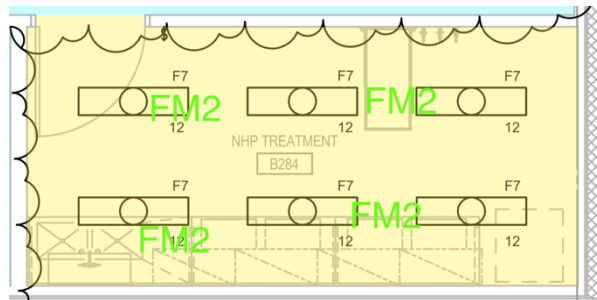

Figure 35: LED Layout

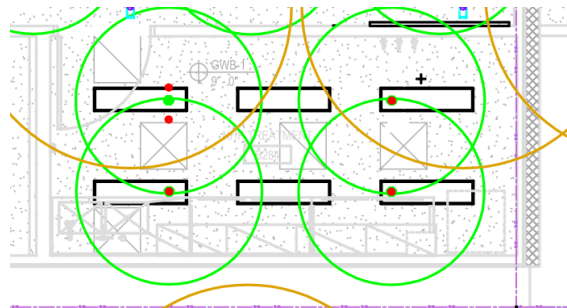

Figure 36: Cochran Photometrics

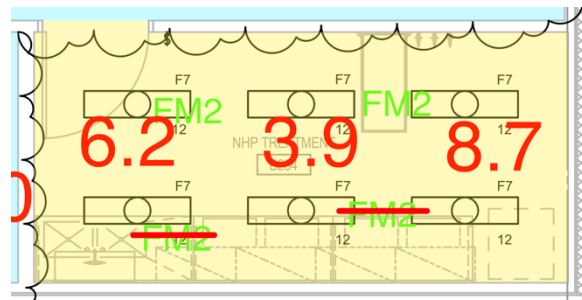

Figure 37: Notes and Observations

Chapter 5 Summary

In review of the lighting meter survey, the study was conducted to gauge whether the LED lighting system was capable of meeting Federal and State levels of compliance. Rooms, corridors and an interstitial maintenance area were all tested for compliance, the result of which found the general tested area met Federal 5FC guidelines, but missed the State code of 10FC by .51FC. However, when comparing different building areas (e.g. rooms, corridors, and maintenance pathway), rooms met and surpassed State guidelines, with a mean foot-candle rating of 12.27FC. One factor for a higher foot-candle average in metered rooms may have been the level of construction completion. All rooms measured had some level of framing, insulation, or drywall completed, the result of which would increase light quality through diffuse reflection (light reflecting off walls).

On the other hand, corridors and interstitial areas, although they met Federal guidelines, did not comply with State illumination regulations. The primary reason being non-adherence to lighting design documents and insufficient maintenance of luminaires. Regarding the maintenance issue, some lights were too high in ceiling penetrations or positioned next to walls and obstacles, stifling beam projection on work areas below. Furthermore, other luminaires were found to be lighting nothing, as they were situated behind or above completed finishes.

LEDs can meet both Federal and State regulations, but require some vigilance on behalf of contractors. If the construction industry wants to reduce material and energy waste, and increase safety on their construction sites, then proper adherence to lighting design and consistent maintenance of temporary lighting is tantamount to efficiency and compliance. Additionally, administrative controls, such as assigned training or information pamphlets could help workers identify illumination hazards and solve lighting waste on jobsites.

Chapter 6.

Glare Analysis

Scope of the Issue

After assessing qualitative survey data, it is apparent that glare produced from Clear-Vu's LEDs were a source of discomfort and distraction for some of the workers. Again, workers reported that they were happy with the illumination quality, yet found it difficult to look in the direction of the lamp due to the LED's brightness. So why might white LEDs (WLED) be such an overwhelming source of glare?

In 2016, the American Medical Association (AMA) published a report titled *Human and Environment Effects of Light Emitting Diode (LED) Community Lighting*. The report summarizes the environmental and economic sustainability benefits of replacing traditional lamps in street lighting with LEDs. However, the report further states that inappropriately selected and installed LEDs can produce visually impairing light, which can be a safety hazard for those driving or walking at night (Kraus. 2016). The primary issues being blue light generated by high color temperature WLEDs, and the high surface density luminance generated by single small-point sources. However, lighting design may also play a role in WLED glare intensity, such as an LED's beam intensity spread, the height placement of a luminaire, the number of luminaires per square foot, and the use of diffusers.

WLEDs get their perceived color through a special yellow phosphor coating placed on a high-energy frequency, blue spectrum LED (Kraus. 2016). Figure 39 shows a graph of a cold white LED in comparison to other traditional lighting sources. WLEDs have a large peak emission of blue in the 400-490 nm range, with an amber color emission peak in the 540-580 nm range, whereas other traditional lighting sources, such as fluorescent and incandescent have less powerful emissions in the concerned ranges.

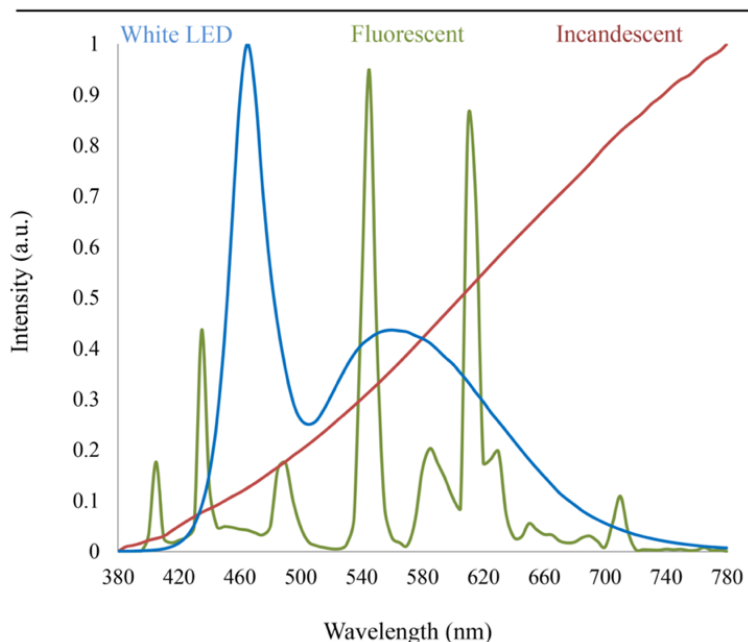

Figure 38: Luminaire Color Spectrum (Source: Tosini, Ferguson, et al. 2016)

Despite our perception of “white” light, WLEDs can still release high exposures of blue light, which tends to scatter more within the eye, creating glare and further contributing to environmental light pollution (Tosini, Ferguson, et al. 2016). Moreover, as the phosphor coating on the diode begins to degrade with use, the filtering qualities of the coating will no longer efficiently absorb the blue spectrum, leading to higher outputs of blue light (Tosini, Ferguson, et al. 2016). The report continues to state that not all WLEDs are pernicious, but the hazard is partly dependent on a WLED’s correlated color temperature (CCT). As a solution to the problem, the AMA report’s conclusion recommends the reduction of blue-rich LED lighting to reduce the potentially harmful effects of glare to human and environmental health (Tosini, Ferguson, et al. 2016).

The lighting industry uses CCT to describe color and tone of white light, with tones varying on a hot to cold gradient. Additionally, the CCT value is expressed in the temperature scale Kelvin (K), which denotes an analogous color of light emitted by metal heated to a determined temperature. For perspective, noon-time daylight is in the 6500K range, while an incandescent bulb runs at 2700K, and a fluorescent tube at 4100K (Tosini, Ferguson, et al. 2016, Lenk and Lenk. 2011). WLEDs commonly come in CCT temperatures between 3000K and 4000K. On the

other hand, Clear-Vu's LED temperatures fall within the 4000K to 5000K ranges as seen in tables 1 and 2.

The AMA reported that WLEDs in the 4000K range can emit twenty-nine percent of its color spectrum as blue light. However, recent commercial availabilities have seen a lowering in CCT values, with temperatures in the 3000K range, which emits around twenty-one percent of its perceived white light in the blue spectrum (Tosini, Ferguson, et al. 2016). Furthermore, it is known that blue light can cause retinal damage and have potentially negative hormonal responses—such as the disruption of the circadian cycle—through photochemical reactions (West, Jablonski, et al. 2011 and AIHA. 2012). And although construction lighting WLEDs are just as safe as other traditional luminaires regarding retinal damaging hazards, blue light emissions from LEDs have been linked to melatonin suppression and sleep-cycle disruption (circadian cycle) during nighttime exposures, which can be problematic for workers trying to get a good night's rest after a hard day's work (West, et al. 2011, Khan, et al. 2014, and Bommel. 2015). On the other hand, since blue light photochemical responses mimic sunlight's, exposure to WLED should be viewed in a time and context framework. Seattle's Lighting Design Lab's senior lighting specialist posited that blue light exposures for nighttime construction workers could have its benefits (Strandberg. 2017). Because blue light exposure suppresses melatonin, workers could experience increased levels of alertness, which could reduce risk of accidents on nighttime construction sites. However, that is a question for another study.

Methodology

To understand workers' perception of discomforting light, it is important to implement a measuring tool to quantify illuminance quality. Within the past few years, interior designers, architects, and researchers have been turning to cost-efficient methods of quantifying glare and illuminance within the built environment. One technique that has proven effective is the use of digital CCD cameras to collect luminance data (Kumaragurubaran. 2012, Suk, Schiler, et al. 2013). By capturing multiple photos and producing a high dynamic range image (HDR), researchers are then able to quantify luminance of a scene using a variety of free software (Kumaragurubaran. 2012, Suk, Schiler, et al. 2013).

Tools Used for Glare Analysis

- CCD Camera: Nikon D3200
- Fisheye Lens: Nikon 16mm f/2.8D AF Fisheye lens: 180-degree field of view
- Spot Luminance Meter: Sekonic L-758CINE-U Light Meter
- Grey Exposure Target
- Tripod: Manfrotto Large Tripod

HDR Photography

An HDR photograph is a combination of multiple photos taken in a series of dynamic ranges. By combining the scenes, a wide breadth of luminance values is stored within the HDR picture—essentially packaging the brightest and darkest points of a portrait. Unfortunately, single images taken on a typical CCD digital camera do not have the value range needed for analysis because the camera is only able to capture a narrow range of what a human eye would perceive. Because the human eye has a dynamic luminance range of 0.0000001 cd/m^2 to $1,000,000 \text{ cd/m}^2$, an HDR image can store luminance, illuminance, and color in a similar way the human eye perceives light and color (Suk, Schiler, et al. 2013). In fact, if implemented correctly, HDR is much more sensitive than the human eye and can capture more luminance and illuminance information as compared to the typical CCD photograph and the human eye, which is described in figure 39.

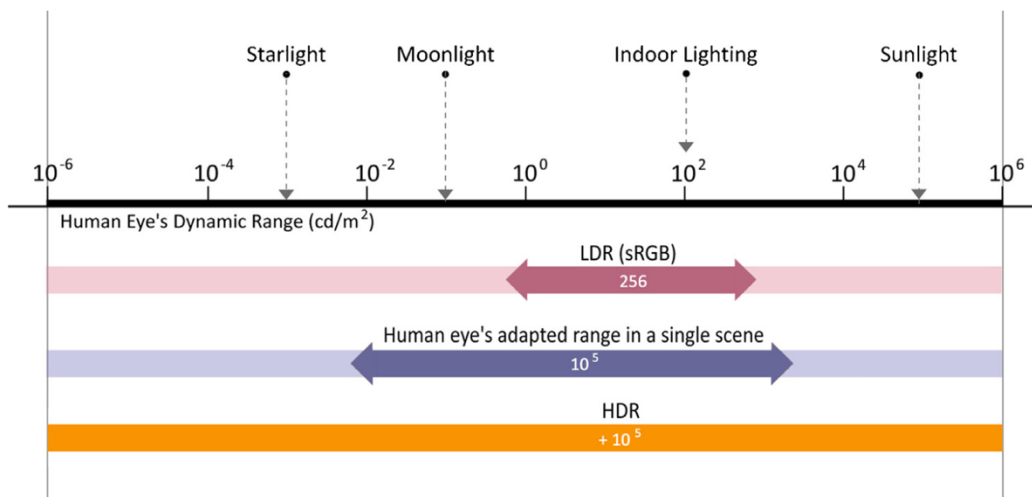

Figure 39: Dynamic Range Comparison (Source: Suk, Schiler, et al. 2013)

Camera Calibration

To develop an HDR image, a CCD camera must be manipulated to capture a series of photos throughout its dynamic range. Typically, the amount of light let into a camera's image sensor is known as an exposure value (EV). However, EV is controlled and dictated by three separate camera functions: aperture, shutter speed, and ISO. Manipulating any one of these variables controls the EV of the image sensor.

Aperture: Controls the area of light hitting the camera's sensor. A larger aperture equals more light exposure. The "F-Stop" value on cameras dictate the size of the aperture, with a smaller F-Stop number equating a larger opening for light.

Shutter Speed: Dictates the length of time the camera's sensor is open to light—usually in fractions of a second. The longer the shutter remains open the more light is directed at the camera's sensor.

ISO: Is the sensitivity a camera's image sensor is to light.

Additionally, it is recommended to use a 180-degree fisheye lens to capture as large of a field of view as possible (Suk, Schiler, et al. 2013). Although an image captured by an 18mm, wide-angle lens is capable of being analyzed, it does not capture as much information as the fisheye lens.

Figure 40 is a series of sample photos taken with a Nikon D3200 camera with a Nikon 18-55mm lens, F-Stop at 5.6, ISO 100, shutter speeds taken between 1/4000 seconds to 2 seconds, and output as a RAW image file.

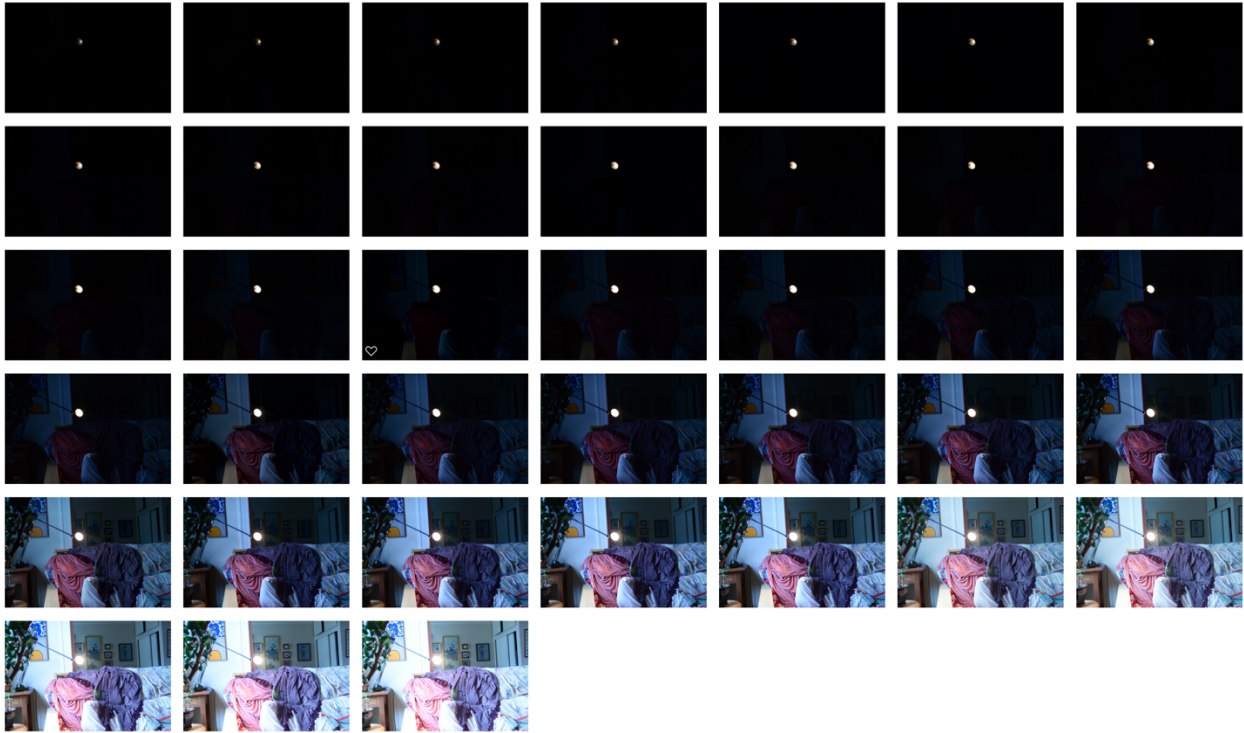

Figure 40: Varying Exposures of a Scene

After the photos have been taken, they need to be combined to generate the HDR image. There are multiple programs which allow the jpeg image format to be combined into a single HDR image. Commercial software, such as Adobe Photoshop allows users to combine photos into single HDR images; however, it does not aid in the luminance calibration of photo, a process which will be described later.

On the other hand, Photosphere, an HDR image builder authored by imaging and lighting researcher Greg Ward, is a tested platform for HDR image generation and lighting calibration (Kumaragurubaran. 2012). Images are loaded into photosphere, and are then selected for merger. See figure 41 for graphic user interface (GUI).

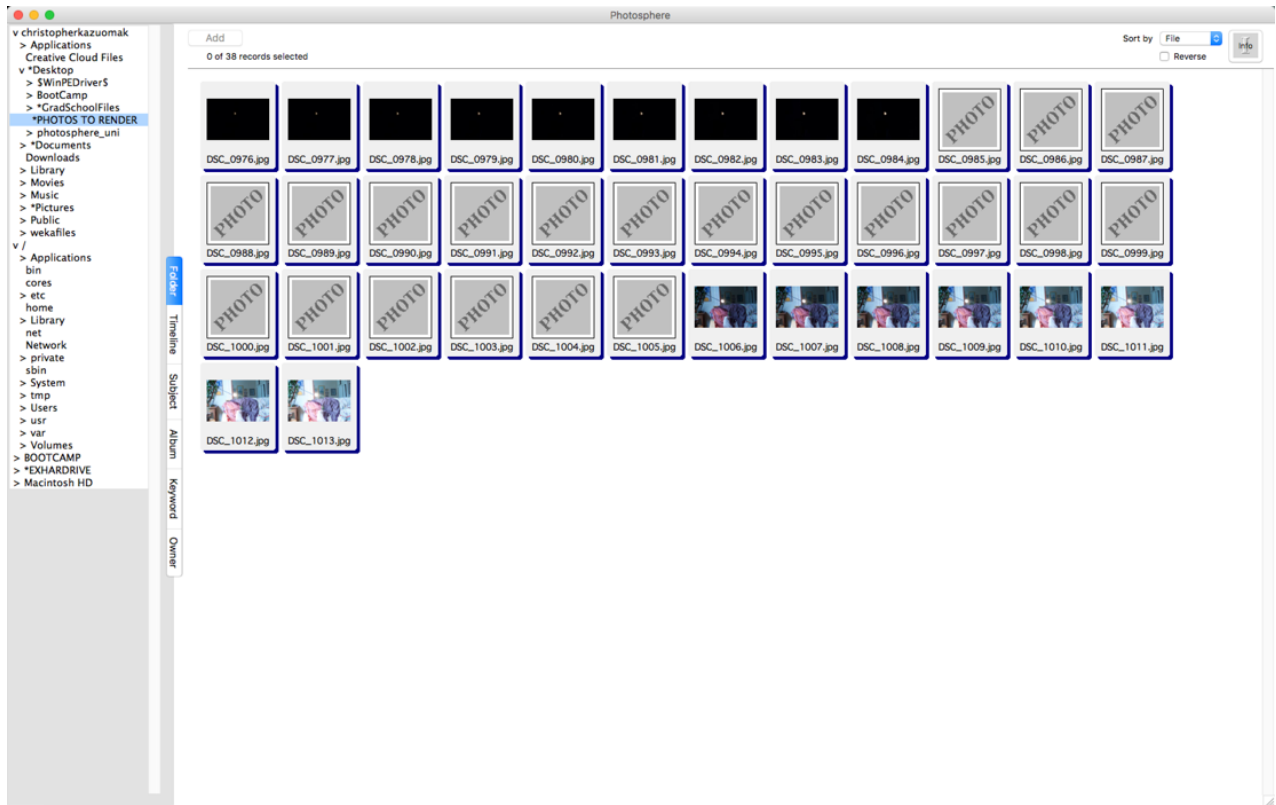

Figure 41: Photosphere GUI Interface

In addition to creating HDR images, Photosphere allows users to edit problems associated with HDR image creation, such as the removal of lens flare and ghosts. Furthermore, it provides other useful tools, like image cropping, color and luminance histograms, and false color renderings.

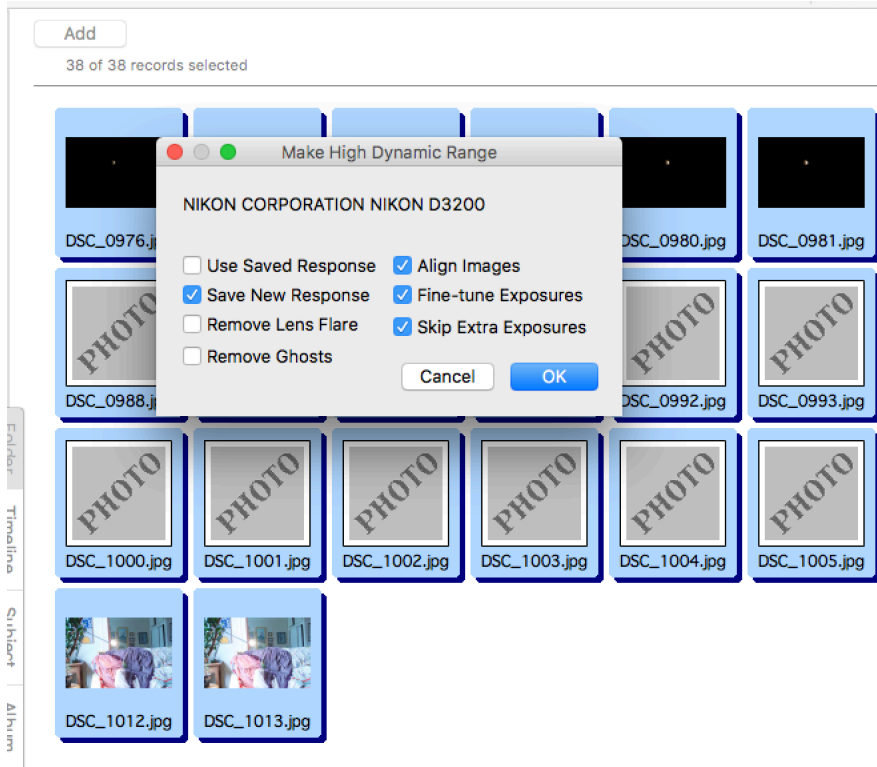

Figure 42: HDR Creation Options

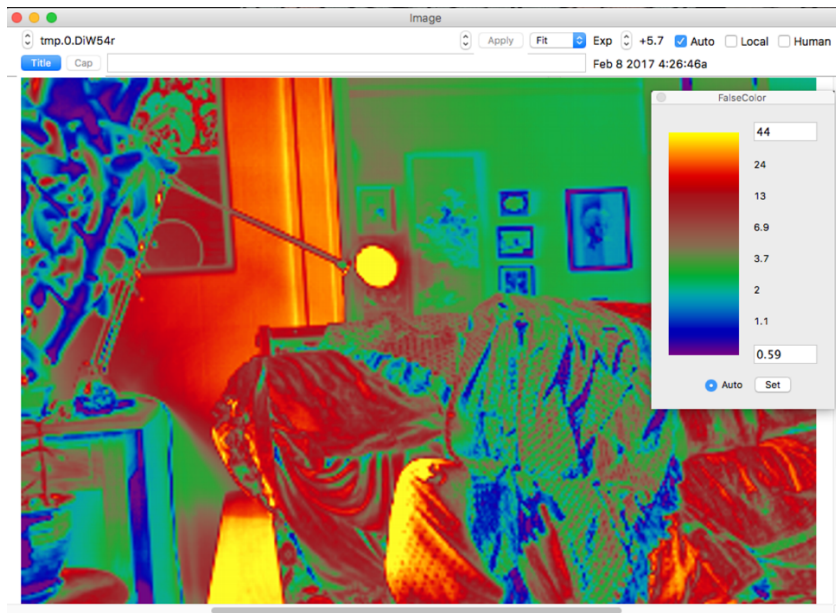

Figure 43: Uncalibrated False Color Rendering

After the HDR image has been created it is of utmost importance that the photograph be calibrated with measured luminance information from the scene to retain accurate lighting data. Measuring a known spot within the photograph can be done with a spot luminance meter, such as a Sekonic L758CINE-U light meter or a Minolta LS-100 Luminance Meter. Although luminance meters are relatively expensive (between \$600-\$3,500), they can be rented for a fraction of the cost. Moreover, this technique is used in professional photography with a grey target card placed in the scene to be photographed to adjust exposure values.

Figure 44 demonstrates a hypothetical luminance calibration of a selected target within the scene. Once a known area has been adjusted for luminance, the entire photograph's pixels will be adjusted, and the data stored within the HDR photograph for further analysis.

Once calibration has been completed, the image is then exported and saved in the Radiance RLE RGBE format.

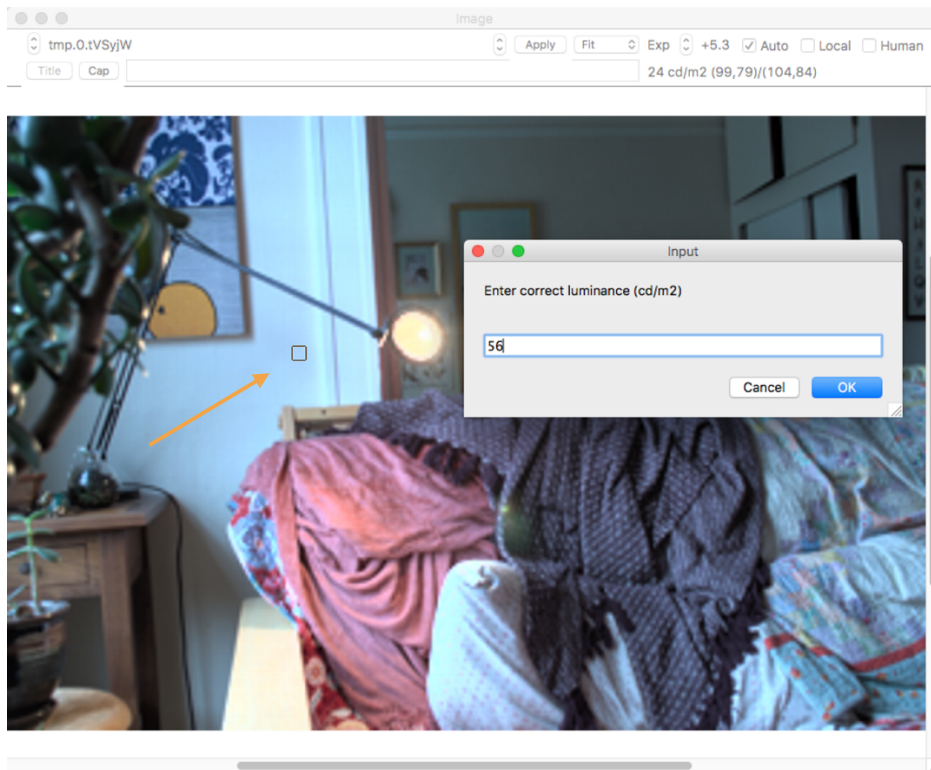

Figure 44: Spot Luminance Calibration

Checking Glare Through EvalGlare

Evalglare is an open-source glare analyzing program developed by lighting researchers Jan Wienold and Jens Christoffersen. Fundamentally, Evalglare evaluates potential glare sources in the HDR format using five different glare indices, but it can be paired with CAD programs, such as Rhino, and used to evaluate glare in computer generated daylighting simulations. The five glare indices are defined below.

Daylight Glare Probability (DGP): developed by Wienold and Christoffersen, DGP evaluates discomfort glare by looking at vertical eye illuminance, glare source luminance, source solid angle, and position index (Suk, Schiler, et al. 2013). Regarding this study, DGP will not be a target index because it works best for daylighting situations, not artificial lighting.

$$DGP = 5.87 \times 10^{-5} \times E_v + 9.18 \times 10^{-2} \times \log \left(1 + \sum_1 \frac{L_{s,i}^2 \times \omega_{s,i}}{E_v^{1.87} \times P_i^2} \right) + 0.16$$

E_v = the vertical illuminance in lux at eye level

L_s = glare source luminance (cd/m²)

ω_1 = solid angle of source (sr)

P = Guth position index

Daylight Glare Index (DGI): Is the primary method for quantifying discomfort glare in a scene. Like its counterpart DGP, DGI is primarily used for daylighting situations, not artificial lighting (Bellia, Cesarano, et al. 2014).

$$DGI = 10 \log \sum_{i=1}^n 0.478 \left(\frac{L_s^{1.6} \cdot \Omega_i^{0.8}}{L_b + (0.07 \omega^{0.5} \cdot L_w)} \right)$$

L_s = glare source luminance (cd/m²)

L_b = luminance of surfaces in a scene, also known as background luminance (cd/m²)

L_w = average luminance of windows in a scene (cd/m²)

ω_1 = solid angle of window (sr)

Ω = solid angle of source (sr)

Unified Glare Rating (UGR): Developed by the International Commission on Illumination (CIE) to evaluate glare from artificial light sources (Bellia, Cesarano, et al. 2014. Wienold and Christoffersen. 2006). UGR is another measure of discomfort glare.

$$UGR = 8 \log_{10} \frac{0.25}{L_b} \sum_{i=1}^n \frac{L_s^2 \omega_s}{P^2}$$

L_s = glare source luminance (cd/m²)

L_b = luminance of surfaces in a scene, also known as background luminance (cd/m²)

ω_s = solid angle of source (sr)

P = Guth position index

Visual Comfort Probability (VCP): Developed to evaluate glare from artificial light, specifically florescent sources (Bellia, Cesarano, et al. 2014). The VCP is a probability of the percentage of people who would find the lighting to be comfortable. VCP is another measure of discomfort glare.

$$VCP = \left[224.4 - 46.8 \cdot \log \left(\sum_{i=1} \left(\frac{0.5 \cdot L_{s,i} \cdot (20.4 \cdot \omega_{s,i} + 1.52 \cdot \omega_{s,i}^{0.2} - 0.075)}{P_i \cdot L_a^{0.44}} \right)^{-0.0914} \right) \right] + 50$$

L_a = average luminance of entire scene (cd/m²)

L_s = glare source luminance (cd/m²)

ω_s = solid angle of source (sr)

P = Guth position index

CIE Glare Index (CGI): The CIE initially developed the CGI as a unified glare index by improving upon the Building Research Station in England's (BRS) glare formula. The BRS's version had difficulty quantifying glare from multiple sources (Wienold and Christoffersen. 2006). CGI is also a measure of discomfort glare.

$$CGI = 8 \log_{10} 2 \frac{[1 + (E_d/500)]}{E_d + E_i} \sum_{i=1}^n \frac{L_s^2 \omega_s}{P^2}$$

E_d = vertical illuminance at eye level (lux)

E_i = indirect illuminance at eye level (lux)

L_s = glare source luminance (cd/m^2)

ω_s = solid angle of source (sr)

P = Guth position index

CIE Veiling Luminance (Lveil): Lveiling is a method for quantifying disability glare. Veiling luminance occurs when luminance from a visual scene is covered or “veiled” by a glare source close to the visual scene (Bommel. 2015). The veiled scene is caused when luminance from a glare source scatters in the eye, reducing contrast from the scene. Figure 45 shows glare source luminance (red arrows) scattering within the eye and interposing on light from a scene.

Unfortunately, Lveil cannot be used to measure glare discomfort among workers, only variation in a scene’s contrast, so it will not be used in this study.

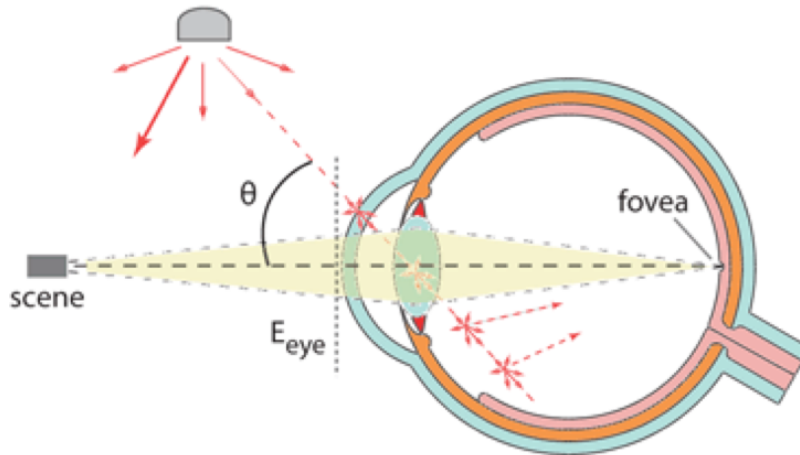

Figure 45: Illustration of Veiling Luminance Within the Eye (Source: Bommel. 2015)

The formula presented for Lveil is for the summation of multiple glare sources.

$$Lveil = 10 \sum_{i=1}^n \frac{E_{(eye)i}}{(\theta_i)^2}$$

$E_{(eye),i}$ = illuminance at the eye level (lux)

θ_i = Angle of the glare source

i = luminance source, in this case a luminaire

Table 47: Jakubiec and Reinhart's Glare Indices (Source: Suk and Schiler. 2013)

Degree of Glare	DGP	DGI	UGR	VCP	CGI
Imperceptible	<0.35	<18	<13	80-100	<13
Perceptible	0.35-0.40	18-24	13-22	60-80	13-22
Disturbing	0.40-0.45	24-31	22-28	40-60	22-28
Intolerable	>0.45	>31	>28	<40	>28

Table 47 represents the degree of glare discomfort as related to the five indices tested by Evalglare. Generally, the higher the glare index, the more disturbing and uncomfortable the glare source is likely to be. VCP, on the other hand, is the probability of comfort, so a lower number indicates a higher probability for discomfort (Suk and Schiler. 2013).

There are currently two methods of using Evalglare: through an extension program or a graphic user interface (GUI); or through UNIX command-line entry.

```

C:\WINDOWS\system32\cmd.exe
Microsoft Windows [Version 10.0.10586]
(c) 2015 Microsoft Corporation. All rights reserved.

C:\Users\chrismac>cd desktop
C:\Users\chrismac\Desktop>cd hdri
C:\Users\chrismac\Desktop\HDRI>evalglare new_hdr
Notice: Low brightness scene. dgp below 0.2! dgp might underestimate glare sources
Notice: Low brightness scene. Vertical illuminance less than 300 lux! dgp might underestimate glare sources
dgp,dgi,ugr,vcp,cgi,Lveil: 0.112477 26.572855 32.902191 0.000000 39.634861 65.690285
C:\Users\chrismac\Desktop\HDRI>

```

Figure 46: Command-line Entry Example

However, University of Washington's Department of Architecture graduate, Viswanathan Kumaragurubaran developed an easy to navigate GUI based around the EvalGlare program called HDRscope. The program was developed as a tool for designers to test and quantify lighting quality. Moreover, the platform allows users unfamiliar with UNIX programming to easily implement the Radiance glare finding suite. In addition to glare analysis, HDRscope provides a variety of image editing services, such as image cropping and sizing, image masking, and image exposure correction. Figure 47 is an HDR scene to be analyzed with HDRscope.

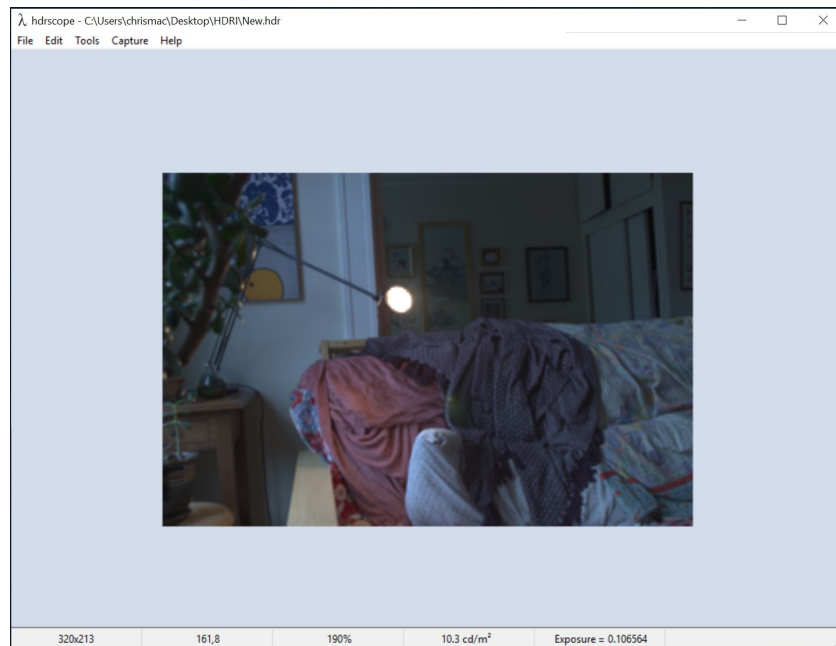

Figure 47: HDR Scope GUI

Once a captured scene has been calibrated for luminance and run through the Evalglare analysis software, HDRscope will output an image which highlights potential sources of glare and will give a discomfort glare analysis. Figure 48 shows the blue highlighted reading lamp as a potential source for glare.



Figure 48: Sample Image Run Through Evalglare

Table 48: Discomfort Glare Indices for Example Analysis

DGP	DGI	UGR	VCP	CGI	Lveil
0.007474	15.686812	18.775085	58.029919	25.629601	2.057846

After running the sample HDR photograph through the HDR Scope the above indices were given. DGP and DGI, which are both daylighting glare indexes, were below perceptibility. On the other hand, the glare indices UGR, VCP, and CGI, which are tuned for artificial lighting, gave discomfort ratings between perceptible and disturbing. See table 48 for degree of glare comfort.

Glare Analysis of Clear-Vu LEDs

On May 4th, 2017, a glare analysis was conducted on the Clear-Vu LED lighting in the ARCF's B02 interstitial area. Using the tools and methods outlined in the section above, the author set up the Manfrotto camera tripod with camera lens positioned 5-feet from the floor. Next, a grey photography target was set up in the photo scene to take accurate spot-meter readings with the Sekonic L-758CINE-U Light Meter. Vertical illumination meter readings were also taken above the camera's 180-degree fisheye lens using the same light meter.

Following the setup of camera equipment, three scenes were photographed in the interstitial area. Each scene had a series of 40 photos taken, with shutter speeds ranging from 1/4000 of a second to 2 seconds. The resulting 120 photos were then developed into three HDR photographs. Each HDR photograph was combined from 40 pictures in the software Photosphere, and were then calibrated with the appropriate spot-meter reading. The resulting HDR photographs can be seen in figures 49 through 51.

After the HDR images were constructed, they were then run through HDRScope’s glare analysis function to search for potential glare sources and to quantify glare perception.



Figure 49: HDR Photograph 1

Table 49: Photograph 1 Measured Variables

Camera Distance to FM10:	4’5”
Vertical Illumination:	107 Lux
Grey Spot Meter Reading:	16 cd/m²



Figure 50: HDR Photograph 2

Table 50: Photograph 2 Measured Variables

Camera Distance to FM10:	6'10"
Vertical Illumination:	53 Lux
Grey Spot Meter Reading:	23 cd/m²

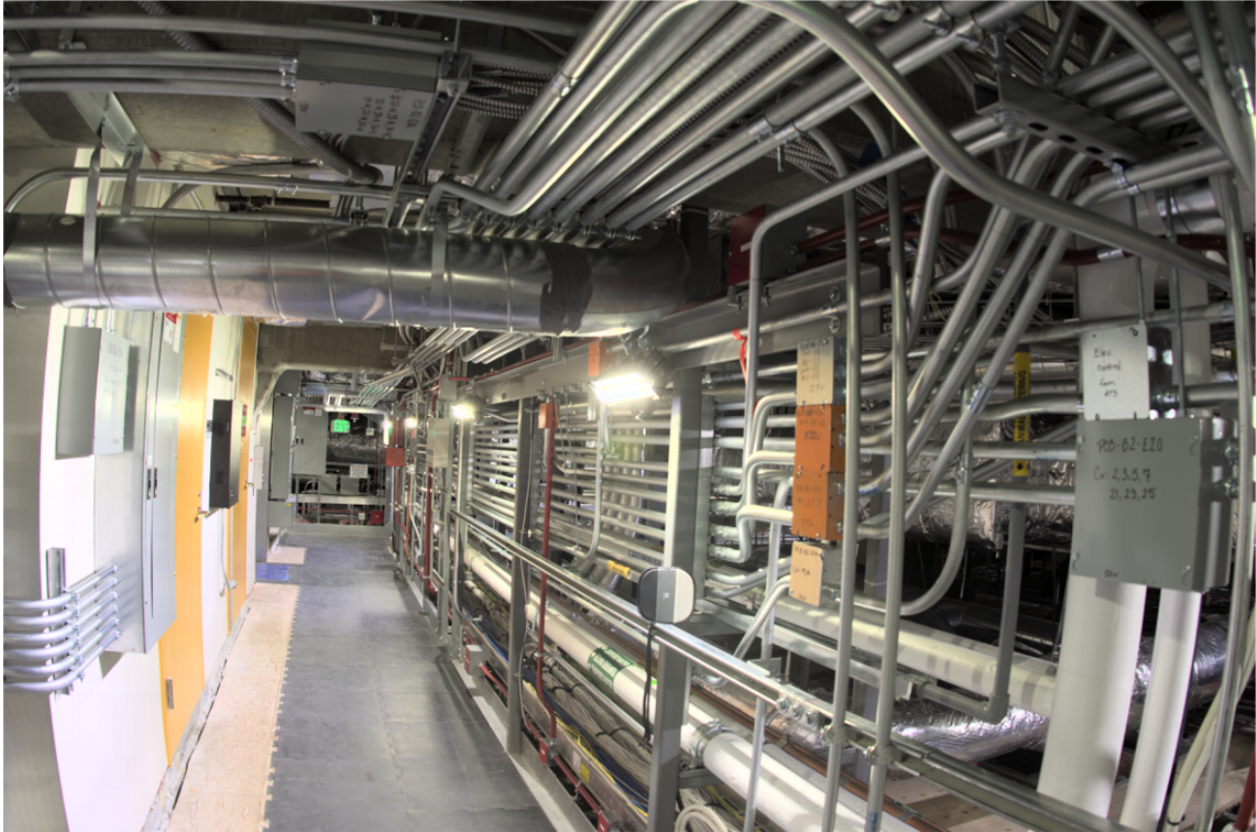

Figure 51: HDR Photograph 3

Table 51: Photograph 3 Measured Variables

Camera Distance to FM10:	7'
Vertical Illumination:	86 Lux
Grey Spot Meter Reading:	12 cd/m²

Figures 52 through 54 are the resulting images from the EvalGlare analysis. The portions highlighted by different colors represent potential glare sources in the scene. Colors are chosen at random by the program and do not represent a quantitative difference in glare perception.

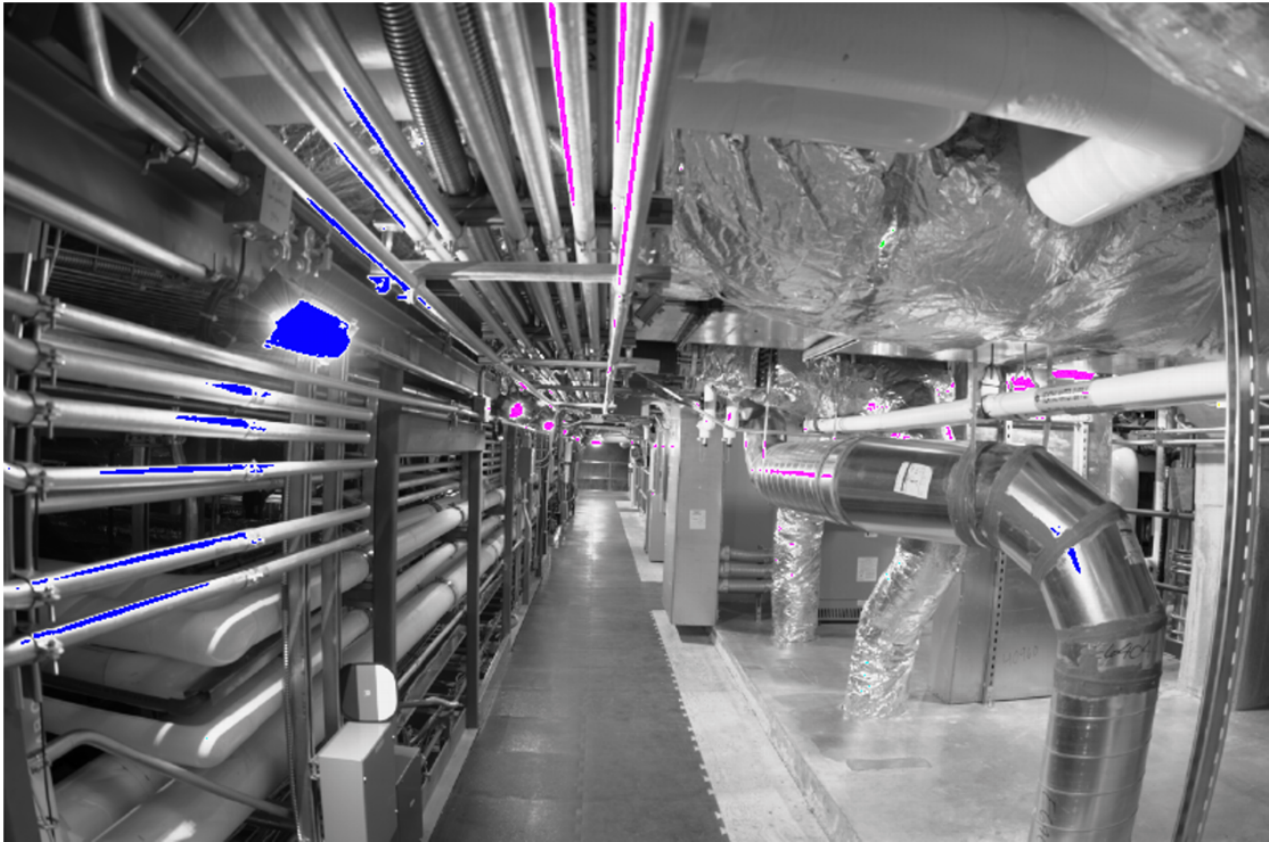

Figure 52: Glare Analysis of Photograph 1

Table 52: Glare Analysis Results for Photograph 1

DGP	DGI	UGR	VCP	CGI	Lveil
0.007292	14.989490	17.458578	91.631752	21.877516	1.987568



Figure 53: Glare Analysis of Photograph 2

Table 53: Glare Analysis Results of Photograph 2

DGP	DGI	UGR	VCP	CGI	Lveil
0.005897	11.422073	12.191263	97.998093	17.192320	0.392901



Figure 54: Glare Analysis of Photograph 3

Table 54: Glare Analysis Results of Photograph 3

DGP	DGI	UGR	VCP	CGI	Lveil
0.005399	9.714427	9.895906	99.137543	15.679733	0.533893

Looking at the following glare indices generated by the program, DGP and DGI, which are both daylighting glare indexes, were below perceptibility for all the photos as the pictures were taken indoors. On the other hand, photograph 1, the UGR and CGI indices indicate that the discomfort glare created by the lights are perceptible, but below even acceptable levels for discomfort glare. Furthermore, the VCP rating of 91.63 estimates that 91.63% of people would find the lights to be comfortable. See table 47 for Jakubiec and Reinhart’s degree of glare perceptibility indices.

For photographs 2 and 3, only the CGI index noted any levels of note. Photograph 2 had a CGI of 17.19, which is in the perceptible range, yet still below discomforting levels. The VCP rating for photograph 2 estimates that 97.99% of individuals would find the lighting in the scene to be

comfortable. Similarly, photograph 3 had a CGI of 15.67, which is in the perceptible range. VCP for photograph 3 estimates that 99.14% of individuals would find the lighting to be comfortable.

Chapter 6 Summary

Unfortunately, respondents to both the UWB P3 and ARCF survey noted that glare from the Clear-Vu LEDs was a problem for them. In response to this concern, review of current research on LEDs and glare revealed that workers were being exposed to a known problem—blue light.

As mentioned in Chapter 1, WLEDs produce their perceived white color by filtering a blue diode through a phosphor. This has the potentially negative effect of releasing high energy blue light during operation. To reiterate the AMA, WLEDs can be a hazard to humans if they are exposed to large enough quantities of blue light, and WLEDs in the CCT range of 4000k release ~29% of their light in the blue spectrum. Blue light has the tendency to create glare for observers, and can disrupt natural sleep cycles, both of which are problematic for worker safety and health.

A quantitative glare study was conducted on Clear-Vu's LEDs using a cheap analysis technique involving HDR photography. Analysis of the HDR photos found evidence that the luminaire's lighting quality was producing glare. In all photographs, discomfort glare was found to be perceptible, yet not disturbing or intolerable. Moreover, the VCP glare index found between 91% - 97.99% of individuals would have found the Clear-Vu LEDs to be comfortable in that situation.

In addition to being a relatively easy way to quantify glare, the HDR photography technique may be helpful for construction projects concerned with glare, such as nighttime highway work. The photography technique proved to be simple and cheap to conduct, and the data was easy to interpret.

Chapter 7.

Seattle City Light Energy Incentive

Seattle City Light Inspection and Rebate Discussions

On September 15th, 2016, the CPD met with representatives of Seattle City Light (SCL) to discuss a potential energy rebate for using the energy efficient Clear-Vu lighting system. In response to the documents provided by the CPD, SCL noted the need for several documents, which included: purchase invoices for the system; duration and construction schedule that documents length of time the lights burn; CAD or construction documents showing light locations; and count of fixtures on the project.

The meeting with SCL exposed several holes about the documentation and treatment of temporary lighting on University of Washington construction sites.

1. The University currently has no inventory system for the Clear-Vu modules that they have purchased. The lack of an inventory system makes it difficult to track the number of lights they have from project to project, what projects the lights are transferred to, and how long the lights are in use or not in use. Furthermore, when researching the deployment history of LEDs at UW, material schedules varied from what was seen in the 2014 case study and what was provided by the General Contractor on site. For instance, it was documented that 285 LEDs were used at UWB P3, but several material schedules from the NanoES project both stated 284 and 287 lights were transferred from the Bothell project.

The inconsistencies between material schedules was not surprising to the CPD, and they further noted that it would not be shocking if someone had stolen a few lights. Without an inventory system, there is just no way of knowing.

2. When SCL asked for a construction schedule or a Gantt chart demonstrating the length of time lights had been on at ARCF, there was no documentation or record. Temporary lighting was not part of the construction schedule. For improved tracking of energy use, including a schedule for install and removal of temporary lighting is a must have for SCL.

3. Finally, the CPD did not have direct access to purchase invoices. They remained in possession of the electrical subcontractor and the material vendor. SCL wanted purchase invoices for the system to prove ownership and light quantities. Furthermore, having an invoice database as well as an inventory system on hand would streamline the rebate process

Seattle City Light Energy Rebate

On November 30th, 2016, the SCL energy rebate for ARCF's temporary and permanent LED lighting use was finalized. After the lessons learned in the ARCF case study, the UW CPD and ARCF stakeholders produced the necessary documents required by the SCL energy incentive team. The forthcoming materials list, costs, and scheduling differed from what Cochran Electric had originally provided to the ARCF project management team and to the author of the ARCF case study. Below in table 55 are updated fixture counts and material costs provided by the UW.

Looking at the updated material list, the total number of fixtures is reduced from 812 temporary lights to 500. FM2s see the largest reduction, with 330 less lights than originally planned, while FM10 fixtures were increased by 18 lights from the planned 322 FM10, totaling to 340 FM10s. Furthermore, the material costs were reduced by around \$20,000 from what was originally projected by Cochran Electric (see table 18). Unfortunately, no costs for installation were provided by the new invoices.

Table 55: Updated LED Material Cost Calculations

Invoice Date	FM2	FM10	Amount
2/23/16	160	210	\$37,730
3/23/16	-	130	\$18,200
2/17/16	-	-	\$35,621
1/21/16	-	-	\$35
Total:	160	340	-
Planned:	490	322	-
Unaccounted:	330	-18	-
Wesco/Cochran LED Materials Cost:			\$91,576
Cochran General Material Items			
-20 Amp 3-pole Breaker Bolt-on:			\$5,950
-Incidental FM2 Material:			\$4,900
-Incidental FM10 Material:			\$3,220
-Mount Permanent Fixtures			\$5,800
Subtotal:			\$111,446
11% EC/CM fee on self-performed work:			\$12,259
Subtotal:			\$123,705
9.6 % Sales Tax:			\$11,876
Total LED materials billed to UW:			\$135,580

SCL temporary LED lighting energy rebate is based on the amount of energy saved over the course of a year. Like the calculations developed in table 21, SCL uses an analogous lighting system as a baseline for energy savings. In this case, the FM2's 10 proposed watts is compared with a 23w CFL, while the 30w FM10 is being compared with a 120w MH light. Calculations for the ARCF temporary lighting incentive are explained below with references from table 55.

$$160 \text{ FM2s} * 10\text{watts} = 1,600 \text{ watts for LEDs}$$

$$160 \text{ CFLs} * 23\text{watts} = 3,680 \text{ watts for CFLs}$$

$$3,680W - 1,600W = 2,080 \text{ watts in energy savings}$$

$$\begin{aligned} 340 \text{ FM10s} * 30\text{watts} &= 10,200 \text{ watts for LEDs} \\ 340 \text{ MHs} * 120\text{watts} &= 40,800 \text{ watts for MHs} \\ 40,800\text{W} - 10,200\text{W} &= 30,600 \text{ watts in energy savings} \\ \text{Total kWh savings} &= 32.68\text{kWh} \end{aligned}$$

$$32.68\text{kWh} * 8,760 \text{ hours a year (24 hour days)} = 286,277\text{kWh savings over baseline}$$

SCL's annual incentive for energy saved is \$0.030 per kWh saved. However, since the project is less than one year long, the incentive is reduced to \$0.028 per kWh saved.

$$\$0.028 * 286,277\text{kWh} = \underline{\$7,873 \text{ incentive for ARCF's project duration.}}$$

The total incentive only accounts for ~6% of the total material costs.

Table 56: SCL Incentive: Updated Temporary Lighting Schedule and Energy Use

	FM2	FM10	Totals
Quantity:	160	340	500
Baseline watts:	23	120	
Proposed LED watts:	10	30	
Watts saved per fixture:	13	19	
Watts saved per size:	2,080	30,600	
KW reduction:	2.08	30.60	
Hours per year:	8,760	8,760	
Annual kWh savings:	18,221	268,056	286,277
Project duration (months):	11	11	
Annual incentive:	\$.030	\$.030	
Project incentive:	\$.028	\$.028	
Payment incentive:	\$501	\$7,372	\$7,873

Regarding the permanently installed LED incentive, SCL uses the Seattle Energy Code (SEC) documentation for energy efficiency calculations in commercial buildings. For the ARCF project, section C405.5.2 Interior Power Lighting was used to set a comparable baseline to know whether the areas fitted with permanent FM10s would save power over what the code’s baseline sets. For ARCF’s interstitial maintenance areas, the space-by-space method was determined to be the most appropriate, which involves selecting the appropriate Lighting Power Density (LPD) from the space-by-space table in the SEC C405.5.2 section. Since the determined areas are an electrical maintenance area, the line item “Electrical/Mechanical” LPD was used, which is .95.

How is LPD determined? LPD is simply calculated by dividing proposed watts in an area by the total square-footage of the determined space; however, as mentioned above, baseline LPD is a fixed variable denoted by the SEC table, so no additional density calculations were required.

Below is a description of how SCL calculated the permanent lighting incentive. See table 57 for calculation variables.

Calculating SCL's Incentive for Permanent Fixtures

Calculating an energy baseline according to Seattle code involved multiplying the .95 LPD with the 6,466 square feet of the interstitial maintenance areas, which gives the code baseline wattage of 6,143 watts:

$$.95 \text{ Electrical/Maintenance Code} * 6,466\text{SF area of interstitial maintenance areas on levels of B02 and B01} = 6143 \text{ Watts}$$

Understanding proposed wattage of ARCF's FM10 permanent fixtures in interstitial areas is simple, just multiple the number of fixtures with the nominal wattage of each fixture:

$$137 \text{ FM10s} * 30\text{W} = 4,110\text{Watts}$$

Finding the energy savings of the new LEDs over the baseline is simple as well, just subtract the proposed LED wattage from the SEC baseline:

$$6143\text{Wh} - 4110\text{Wh} = 2,033\text{Wh or } 2.03\text{kWh}$$

Energy savings of the new fixtures per year are found by multiplying the kWh saved by the assumed hours per year. In this case, we are assuming the lights remain active 18 hours per day.

$$2.033\text{kWh saved} * 6,575\text{hrs per year (assuming 18 hour days)} = \sim 13,364 \text{ Annual kWh saved}$$

SCL lighting incentive is \$0.23 per kWh saved, so by multiplying the incentive by the kWh saved, the resulting number is the monetary incentive paid by SCL.

$$\$0.23 * 13,364kWh = \underline{\$3,074 \text{ incentive for LED permanent lighting.}}$$

Table 57: SCL Incentive: Updated Permanent Lighting Schedule and Energy Use

	FM2	FM10	Totals
Quantity:	-	137	137
Code allowance, w/sf LPD:	-	.95	
-SF Area, Level B02	-	3,660	
-SF Area, Level B01		2,806	
Code watts allowed at ARCF:	-	6,143	
	-		
Proposed LED watts/fixture:	-	30	
Proposed watts, permanent fixtures:	-	4,110	
Watts saved vs. Code allowance:	-	2,033	
kW saved vs. Code allowance:	-	2.03	
Hours per year:	-	6,575	
Annual kWh savings:	-	13,364	13,364
Lighting Incentive:		\$.23	
Payment incentive (one time):	-	\$3,074	\$3,074

Chapter 7 Summary

The combined total incentive for temporary LED lighting and permanent LED lighting fixtures at ARCF amounted to \$10,946. Although relatively small compared with the total cost, the incentive paves the way for more project rebates. Now, each project that implements the temporary LED lighting system on the University's campus only needs to provide: (1) an SCL

inspection, (2) material and installation cost invoices, (3) a material schedule, (4) CAD or construction drawings denoting luminaire locations, and (5) an installation and removal schedule. Furthermore, the Clear-Vu system and associated materials will be reused across campus projects, increasing the value the rebate will have in terms of further offsetting material, installation, and project energy costs. In fact, based on the temporary lighting investment alone, SCL calculated a simple payback period based on estimated annual energy savings—around \$20,994--and SCL monetary incentive, totaling around 5.2 years.

Regarding the permanent LED lights, the SCL incentive predicts an annual cash savings of \$1,069 per year with an estimated simple payback of 15.1 years assuming electricity rates stay at \$0.08 per kWh. Additionally, the environmental impact the LEDs will have is a reduction of around 8 tons of greenhouse gases per year.

Although SCL is open to providing more temporary LED construction lighting incentives to the Seattle construction industry, there is a limitation on the offer. SCL noted that once the practice becomes an industry standard, the local utility will remove the rebate. The incentive is meant to be a carrot for contractors and owners, to reduce energy use and increase environmental sustainability in Seattle.

Chapter 8.

Conclusions

Design and Safety Benefits

UW's investment in LEDs as temporary construction lights was a bold leadership move towards improving the safety and sustainability of campus construction sites. Although initially expensive, Clear-Vu's luminaire system offered advantages over their traditional lighting counterparts: (1) they provide greater, more efficient luminance; (2) are low voltage, which means they do not require a journeyman electrician to install; (3) the low voltage system removes electrocution hazards, especially in wet areas; and (4) the luminaires save between 13 to 19 watts per traditional fixture.

Along with the designed characteristics of Clear-Vu's lights, LEDs possess inherent safety qualities: (1) they produce a relatively low amount of heat, allowing users to safely touch them while in operation; (2) do not contain the toxic chemical mercury; (3) LEDs do not catastrophically fail, rather they slowly dim over time; and (4) LEDs are much more durable and have a longer lifespan than traditional lights.

Diode durability and the reduced maintenance requirements of a LED system became the subject of a 2010 NIOSH supported study, where researchers found that 53% of lighting-related injuries were a result of hazards linked to traditional lighting maintenance, such as heat, electricity and fall hazards. Because traditional lights are less durable and have a much shorter lifespan than LEDs, workers are exposed to those hazards more often. The study concludes that workplace safety can be improved by switching to LEDs, thereby reducing or eliminating hazards associated traditional lighting and maintenance.

UW Developed Study: UW Bothell Phase 3

Yi Jie Huang's research at UWB P3 uncovered the back-end savings the Clear-Vu system could produce over the course of a year-long project. For a similarly sized traditional lighting system, LEDs would have cost over \$13,000 extra to invest in; however, savings netted from maintenance, removal, and energy expenditures would wind up saving the project ~\$34,000. In total, the 74,000sqft construction site cost around \$1.30 per square foot to light with LEDs.

The planning and installation of the temporary LEDs was unique to the project. Wiring for the luminaires were embedding into the concrete slabs, so extra coordination with the ironworkers during the formwork process was crucial. However, the installation method allowed the lights to be used immediately once the concrete had cured. The wire imbeds allowed the lights to remain in the building longer, as LEDs were removed when permanent lighting was installed. This allowed greater use, effectively maximizing deployment times. Furthermore, longer use potentially increased safety through light quality, and minimized waste by reducing equipment downtime.

Case Study: ARCF

Regarding the cost analysis conducted in the ARCF case study, the year-long use of a traditional system versus LEDs favored the latter through cost savings in maintenance and energy expenditures---similar to UWB P3's findings. Original cost estimates prior to the SCL rebate put lighting the 85,000sqft facility at around \$4.38 per square foot, with comparative savings to traditional lighting around \$29,000. The explanation regarding why it cost so much more to light the ARCF than UWB P3 include the complexity of installing luminaires in the underground facility, and the process of lowering lights to match worker activity.

When looking at the foot-candle data collected on level B2, the illumination levels provided by the Clear-Vu lighting system mostly met the 5-foot-candle standard set by OSHA (see tables 45 and 46). Across the 13,958sqft area, there was still difficulty meeting the WAC 10 foot-candle standard. Average readings across the tested area was around 9.49 foot-candles. Again, this was primarily due to design and maintenance issues.

Worker Survey

The combined survey results of thirty-two workers' qualitative responses toward their perception of the quality of lighting on both UWB P3 and ARCF sites, discovered that workers were much happier with Clear-Vu's LEDs over traditional construction lighting. Across five categories, which include: (1) amount of light provided; (2) light was consistent and well distributed; (3) productivity; (4) visual comfort; and (5) safe operation of work, the LEDs always scored higher than their traditional lighting counterparts.

In the write-in section of the survey, most workers agreed that they liked the lights, and commented how the LEDs emitted little heat and were safe to touch while in operation. Again, one issue that was raised by several workers was the lighting intensity of the LEDs, as some workers wrote the glare made it difficult to look in the light's direction.

Glare Analysis

The qualitative responses from several workers regarding LED lighting intensity prompted a glare analysis of Clear-Vu's FM10s in ARCF's interstitial maintenance areas. Using an HDR photography technique outlined in the glare analysis methodology section, three scenes were captured and analyzed. The glare evaluation noted that discomfort glare was only perceptible and below thresholds that would be considered an "acceptable" amount of glare. In photograph 1, the software noted that 91.63% of individuals would find the light comfortable, photograph 2 97.99% of individuals would find the light comfortable, and photograph 3 99.13% of individuals would find the lighting to be comfortable.

Seattle City Light Review

ARCF's temporary LED lighting system became the recipient of a new and unique energy rebate from SCL. After providing the required materials list, installation schedules, and purchase invoices, SCL issued the rebate based around the length of time the LEDs were in operation and how much energy the lights would save over a calculated baseline. In total, the temporary lighting system received only \$7,873 for the year-long use of the LEDs, which accounts for ~6% of the total material cost. However, SCL calculated a simple payback period using estimated annual energy saved— \$20,994—and the annual SCL monetary incentive. The estimated simple payback period for the system would total around 5.2 years.

Although the initial incentive is small compared with the total material cost, the UW will re-use these lights across all their campus construction projects. Furthermore, SCL agreed to continue the incentive, the UW only needs to provide the required documents and an inspection for each new construction project.

Lessons Learned

Finally, despite all the benefits an LED system possesses, there are a few important caveats and pointers for the construction industry to consider when implementing a LED temporary lighting program.

1. There needs to be wider incentive to adopt LED lighting technology by builders, not just owners, like the University of Washington. Although cost analysis in both case studies show that contractors stand to save money from installation, maintenance, and removal expenses when compared with traditional lighting, the competitive bidding process and lack of contract requirements for sufficient general illumination may be stifling the shift to LEDs. Furthermore, typical lump sum bids do not separate temporary lighting costs, so the winning contractor is the sole investor and benefactor of the LED's upfront cost and financial benefits. Unless there is a cost savings contract provision, the project owner will not likely see any financial benefit to using LEDs.
2. If contractors decide to invest in a LED luminaire system, they need to take the time to create a tracking and inventory program. Doing so would primarily assure that lights do not go missing because of theft or careless installation/removal practices. During the SCL rebate process, it was discovered that tracking the material was difficult and some lights may have gone missing during the move from the Bothell project to the Seattle campus. Plainly, it was unknown what happened to UW's lights because no one was paying attention.

Additionally, a tracking system would help contractors really understand material maintenance costs, and facilitate a lighting rebate, as proof of lighting counts is mandatory information for SCL. Furthermore, the unresolved issue of nebulous material counts is an inefficient use of a contractor's time and a wasteful expenditure of a costly investment.

3. Next, the WAC can be confusing, offering little in the way of precise definitions. Contract provisions need to clarify general illumination and task lighting definition

requirements. As noted in the stakeholder interviews on both ARCF and UWB P3 projects, there was confusion regarding how much lighting to provide and where. Documents should clearly define what task and non-task areas are, so contractors understand where it is appropriate to apply the 3 foot-candle versus the 10 foot-candle requirement.

4. Lights need to be properly maintained. As demonstrated in figures 3, 32, 33, and 34, lights that are not properly hung waste energy, money, and will not provide the code appropriate illumination levels.

Furthermore, dark areas generated by lack of maintenance or improper installation create an easily avoidable hazard for workers. If contractors implemented a simple administrative control--providing training and information regarding lighting quality—workers could easily identify and remedy maintenance issues.

5. Lights should be installed to specifications. Again, if lights had been installed where Clear-Vu or Cochran's original photometric documents had specified, then perhaps dark areas, such as those in figures 30 and 32, could have been avoided.
6. One final issue that may need to be addressed in further research is the brightness and color of white LED lamps. Workers in both surveys reported they were generally happy with the illumination quality; yet, they complained of the glare when looking directly in the lamp's direction.

Upon further investigation of the glare issue using HDR photography, the analysis noted that glare levels were below discomforting levels and that more than 91.6% of individuals would find the lighting to be comfortable. That is not to discredit the workers' opinions, as the analysis did note that discomfort glare was perceptible.

It is known that glare created by white LEDs can be a potential hazard, distracting, blinding, and causing discomfort amongst exposed workers. But how do trades or

contractors address the issue without hampering workers' ability to see? One industry expert believes that this is a non-issue. The senior lighting specialist at the Lighting Design Lab (LDL), which is supported by Seattle City Light, thinks that the industry, if they have not already, will solve the problem with new chip designs. According to the LDL, solid state LED chip technology is evolving and improving every six months, and the glare probably will not be a future issue.

Although other researchers have made recommendations to lower CCT temperatures of white LEDs because of potential negative impacts on human and environmental health, blue light may provide photo-biological benefits to workers in certain settings, raising their alertness levels, and potentially reducing alertness-related hazards. The LED industry has been trying to mimic the natural white light we are exposed to on a clear, sunny day, and in many ways, they have succeeded. However, on a biological timeline, humans have been exposed to LED light for a very short time, and psychological and physiological effects of LED exposure has yet to be fully understood. Moreover, the issue of trying to find solutions to present problems of a rapidly evolving technology is hard to balance. However, the author believes that the monetary, ecological, and safety benefits of LEDs have more than solidified their presence in the world, and will quickly make a positive impact in the construction industry when they are widely adopted.

Regarding the glare measuring technique, the HDR analysis is a relatively cheap and easy method to quantify lighting quality. The analysis provides helpful safety information for personnel concerned with hazards associated with glare. The technique is certainly accessible to the construction industry, and would be especially helpful for nighttime highway construction crews who need to consider the effect their temporary lighting may be having on drivers and workers.

References

- AIHA Non-Ionizing Radiation Committee. (2012). *Blue Light Hazard Quick Reference Sheet* (1st ed., Issue brief).
- American National Standards Institute, Illuminating Engineering Society of North America, & Global Engineering Documents. (2001). *Recommended practice for lighting industrial facilities*. Illuminating Engineering Society of North America Industrial Lighting Committee. New York, NY
- Behar-Cohen, Martinsons, Viénot, Zissis, Barlier-Salsi, Cesarini, . . . Attia. (2011). “Light-emitting diodes (LED) for domestic lighting: Any risks for the eye?” *Progress in Retinal and Eye Research*, 30(4), 239-257.
- Bellia, L., Cesarano, A., Iuliano, G., Spada, G. (2014). *Daylight Glare: A Review of Discomfort Indexes*. Università degli Studi di Napoli Federico II.
- Bommel, W. (2015). *Road lighting: Fundamentals, Technology and Application*. Cham: Springer.
- Boyce, P. (2014). *Human Factors in Lighting* (Third ed.). Boca Raton: CRC Press/Taylor and Francis.
- Cai, H., Saifan, M., & Killeen, J. (2015). “Case studies of a camera-aided imaging method for evaluation of interior luminous environments.” *Indoor and Built Environment*, 24(5), 658-671.
- Clear-Vu. (2016). “About Us.” <http://clearvulighting.com/company/about-us/> (May 23, 2016).
- Clear-Vu. (2016) “Products: Construction.” http://clearvulighting.com/category_products/construction/ (May, 23 2016).
- Cochran, Inc. (2016). “EC/CM Breakdown Summary.” University of Washington, Capital Projects Office.
- Dalldorf-Jackson, D. (2015). “Optimizing Worker Safety: It's in the Lights.” *Occupational Health & Safety (Waco, Tex.)*, 84(9), 58, 60
- Department of Energy. (2017). LED Lighting Facts. Retrieved from <https://energy.gov/eere/ssl/led-lighting-facts> (February 7, 2017).
- Department of Energy. (2016). LED Lighting Facts: LED Lumen Maintenance and Warranty Label Changes Frequently Asked Questions. http://www.lightingfacts.com/downloads/lumen_maintenance_faq.pdf (January 21, 2017).
- Descottes, H., & Ramos, Cecilia E. (2011). *Architectural lighting: Designing with light and space* (1st ed., Architecture briefs). New York: Princeton Architectural Press.

El-Rayes, K. Liu, L., Soibelman, L, and Hyari, K. (2003). “Nighttime Construction: Evaluation of lighting for highway construction operations in Illinois.” *Technical Report No. ITRC FR 00/01-2*, Illinois Transportation Research Center, Illinois Department of Transportation, Edwardsville, Illinois.

El-Rayes, K., et al. (2008). “Nighttime construction: Evaluation of lighting glare for highway construction in Illinois.” *Research Rep. No. FHWA-ICT-08-014*, Illinois Center for Transportation, Urbana, Ill.

Harrell, Jay. (7 August, 2016.) [Personal Interview]

Huang, Yi Jie. (2014). *Temporary Construction Lighting Low Voltage LED Lighting System UW Bothell Phase 3*. http://clearvulighting.com/wp-content/uploads/downloads/ClearVuLighting_University-of-Washington-Report.pdf (May 23, 2016).

Khan, T., Bodrogi, P, & Winkler, H. (2014). *LED Lighting: Technology and Perception*. Hoboken: Wiley.

Kraus, L. J.. (2016). “Human and Environmental Effects of Light Emitting Diode (LED) Community Lighting.” (Rep. No. 2-A-16). American Medical Association.

Kumaragurubaran, V., & Inanici, Mehlika. (2012). *High Dynamic Range Image Processing toolkit for Lighting Simulations and Analysis*. University of Washington.

Labor and Industries. (17 June, 2016.) [Email interview]

Labor and Industries. (20 June, 2016.) [Email interview]

Lenk, R., & Lenk, Carol. (2011). *Practical lighting design with LEDs* (IEEE Press series on power engineering). Hoboken, N.J.: Wiley-IEEE Press.

Lunau, K. (2013). “The Incandescent Light Bulb.” *Maclean's*, 126(52), 122.

Odeh, I. (2010). *Evaluation of Glare and Lighting Performance in Nighttime Highway Construction Projects*. University of Illinois at Urbana-Champaign.

OSHA. (2016). “Safety and Health Regulations for Construction.” https://www.osha.gov/pls/oshaweb/owadisp.show_document?p_table=STANDARDS&p_id=10630 (June 1, 2016)

Peña-García, Hurtado, & Aguilar-Luzón. (2015). “Impact of Public Lighting on Pedestrians’ Perception of Safety and Well-being.” *Safety Science*, 78, 142-148.

Rea, M., & Illuminating Engineering Society of North America. (2000). *The IESNA lighting handbook: Reference & application* (9th ed.). Illuminating Engineering Society of North

America. New York, NY.

Rea, M., Bullough, J., Skinner, N., Snyder, J., and Besenecker, U. (2014) "Nighttime Highway Construction Illumination." *SPR Research Study*. No. C-08-14. Troy, NY

Saifan, M., Cai, Hongyi, Change, Jae, & Medina, Mario. (2014). *Exploration of High Dynamic Range Photography as a Useful Tool for Lighting Design*. University of Kansas.

Smith, B. (2008). "Temporary Construction Lighting of Buildings: An Evaluation of Four Techniques, Both Qualitative and Quantitative." *International Journal of Construction Education and Research*, 4(2), 132-149.

Smith, B. W., & Farrow, C. B. (2007). "Improved temporary construction lighting as a method of improving productivity and quality." *Lean Construction: A New Paradigm for Managing Capital Projects - 15th IGLC Conference*, 294-301.

Smith, B. W. (2007). "Improving temporary lighting for buildings under construction: A cost-benefit analysis." *Construction and Building Research Conference of the Royal Institution of Chartered Surveyors, COBRA 2007*, Construction and Building Research Conference of the Royal Institution of Chartered Surveyors, COBRA 2007, 2007.

Strandberg, E. (2017, January 11). Interview with Senior Lighting Specialist at the Lighting Design Lab [Personal interview]

Suk, Schiler, & Kensek. (2013). "Development of new daylight glare analysis methodology using absolute glare factor and relative glare factor." *Energy & Buildings*, 64, 113-122.

Suk, J., & Schiler, M. (2013). "Investigation of Evalglare software, daylight glare probability and high dynamic range imaging for daylight glare analysis." *Lighting Research & Technology*, 45(4), 450-463.

Tashiro, Kawanobe, Kimura-Minoda, Kohko, Ishikawa, & Ayama. (2015). "Discomfort glare for white LED light sources with different spatial arrangements." *Lighting Research & Technology*, 47(3), 316-337.

Tatum, M., Smith, B., & Ben Farrow, C. (2010). "Creating a specification for installation and maintenance of temporary lighting in buildings under construction." *COBRA 2010 - Construction, Building and Real Estate Research Conference of the Royal Institution of Chartered Surveyors*, COBRA 2010 - Construction, Building and Real Estate Research Conference of the Royal Institution of Chartered Surveyors, 2010.

Tayyari, F., & Smith, J. L. (2003). *Occupational ergonomics: Principles and applications* (1st ed., Manufacturing systems engineering series). Dordrecht: Kluwer Academic. Boston, Mass.

Tosini, G., Ferguson, I., & Tsubota, K. (2016). "Effects of blue light on the circadian system and eye physiology." *Molecular Vision*, 22, 61-72.

Tyukhova, Y. (2015). *Discomfort Glare from Small, High Luminance Light Sources in Outdoor Nighttime Environments*. University of Nebraska.

Van Bommel, Ir.W.J.M., Van Den Beld, Ir.G.J., & Van Ooyen, Ir.M.H.F. (2002). "Industrial Lighting and Productivity." *Philips Lighting*. The Netherlands

Washington State Department of Transportation. (2014). "Work Zone Traffic Control Guidelines for Maintenance Operations." <http://www.wsdot.wa.gov/Publications/Manuals/M54-44.htm> (June 6, 2017)

West, K., Jablonski, M., Warfield, B., Cecil, K., James, M., Ayers, M., . . . Brainard, G. (2011). "Blue light from light-emitting diodes elicits a dose-dependent suppression of melatonin in humans." *Journal of Applied Physiology (Bethesda, Md: 1985)*, 110(3), 619-26.

Wienold, & Christoffersen. (2006). "Evaluation methods and development of a new glare prediction model for daylight environments with the use of CCD cameras." *Energy & Buildings*, 38(7), 743-757.

Wikipedia Contributors. (2016). "Fluorescent lamp." https://en.wikipedia.org/wiki/Fluorescent_lamp (June 17, 2016).

Yin, H., Schiler, Marc, Suk, Jae Yong, & Woll, Edwin. (2011). *Glare Studies: Comparison of Three Glare Indices, HDR Imaging and Measured Values*. University of Southern California.

Yenchek, & Sammarco. (2010). "The potential impact of light emitting diode lighting on reducing mining injuries during operation and maintenance of lighting systems." *Safety Science*, 48(10), 1380-1386.

Appendix

Survey Questions



Purpose:

The University of Washington is conducting research on the use of LED based low voltage lighting system for temporary construction lighting at UW ARCF. As workers on this site, we would like to obtain your feedback on working in and with the LED lighting.

There are no known risks and adverse effects to you by providing your opinions in this survey. We will also protect your confidentiality and privacy in any publications and presentations.

Contact for information about the study:

If you have any questions or require further information with respect to this study, please feel free to contact us:

UW CPO Senior Construction Manager: Jeff Angeley (206.391.1836 | angeley@uw.edu)

UW CM Advising Faculty Member: Ken-Yu Lin (206-616-1915 | kenyulin@uw.edu)

CPO Project Intern: Christopher Mak (360-927-2066 | makc@uw.edu)

Definition:

TRAD: Traditional lighting is egress lighting only (corridors and stairwells) by compact fluorescent and metal halide fixtures and task lighting by trade contractors

LED: LED lighting is general lighting everywhere where workers are working to 5ft with low-volt fixtures and task lighting by trade contractors



Important! Please read the definition before filling out the survey.

PERSONAL DETAILS

- 1. Name: _____
- 2. Mobile number/Email: _____
- 3. Trade: _____
- 4. Years of field experience: _____

SITE WORK

5. What activity did you carry out on site?

6. Where was the activity carried out? Please check all that applies.

- In the staircase
- Along the corridor
- In a room
- Others (Please specify) _____

7. What are the lighting requirements for the activity in a **traditional** lighting setting?

Please check all that applies.

- None
- General lighting
- Headlamp
- Task lamps (Please specify no.) _____
- Others (Please specify) _____

8. Was task lighting required **on this site** for the activity? Yes / No

9. If task lighting was used, where was task lighting required? Please check all that applies.

- In the staircase
- Along the corridor
- In a room
- Others (Please specify) _____

10. If task lighting was used,

a) How much task lighting was required? b) How often was task lighting required?

- | | |
|--|--|
| <input type="checkbox"/> 1 task lamp | <input type="checkbox"/> Once a week |
| <input type="checkbox"/> 2 task lamp | <input type="checkbox"/> More than once a week |
| <input type="checkbox"/> More than 2 task lamp | <input type="checkbox"/> Everyday |

11. Please rate your work experience in the two systems –

- TRAD – Traditional lighting is egress lighting only (corridors and stairwells) by compact florescent and metal halide fixtures and task lighting by trade contractors
- LED – LED lighting is general lighting everywhere where workers are working to 5ft with low-volt fixtures and task lighting by trade contractors

On a scale of 1 to 5, where

(1) bad (2) poor (3) fair (4) good (5) excellent

	TRAD	LED
A Amount of lighting provided to carry out your work	_____	_____
B Consistent and well distributed lighting provided	_____	_____
C How productive did you feel?	_____	_____
D Was it visually comfortable?	_____	_____
E The safe operation of your work	_____	_____

On a scale of 1 to 5, where 1) disagree (2) somewhat disagree (3) neutral (4) somewhat agree (5) agree

	TRAD	LED
F You were distracted from working properly	_____	_____
G There was more disruption to your work	_____	_____
H The system required more coordination efforts with other trades/activities	_____	_____

11. Was the LED temporary lighting more helpful for your work or did it make it more difficult to work? Why?

12. Did working in the LED temporary lighting require any additional work / adjustments on your part? Yes / No

13. If yes, what were these additional work / adjustments?

14. Can we contact you if we have further questions? Yes / No

Thank you for your time!
Please return the survey to Christopher Mak at the CPO main trailer.