

**SPIRITUAL DETOUR: THE NORTH CASCADES NATURE
RETREAT AND MEDITATION CENTER**

Paul Christopher Ramey

A thesis submitted in partial fulfillment of the requirements for the degree of

Master of Architecture

University of Washington

2012

Committee: Robert Corser (chair) & Dr. Robert Mugerauer

Program Authorized to Offer Degree: Architecture



To Rebecca & Sierra, my sustenance and inspiration.



Acknowledgements

I would like to thank Rob and Bob for their invaluable input and support in helping my vision come to fruition. I would also like to thank my friends and studiomates for everything that those prestigious titles entail.

TABLE OF CONTENTS

Introduction	1
Problem Statement	3
Rationale	
Theoretical Framework	
Literature Review	9
Site	17
Background	
Analysis	
Design	34
Program	
Concept	
Journey	
Material Phenomenology	
Conclusion	67
Bibliography	69



Figure 1. Photograph of Diablo Dam from the west.

INTRODUCTION

There are three elements in the list of basic needs: food, water and shelter. Architecture would obviously fall under the category of shelter, but how does this term “shelter” describe architecture. Shelter is defined as “a shielded or safe condition; protection” (Oxford University Press 2012). And shelter, as it is used in the list of basic needs and its original intent, is shielding or protecting one from nature. While this need of protection from nature was a very real concern for people for thousands of years, many inhabitants of modern society have reached a point where the opposite is true: people need to find ways to expose themselves to nature.

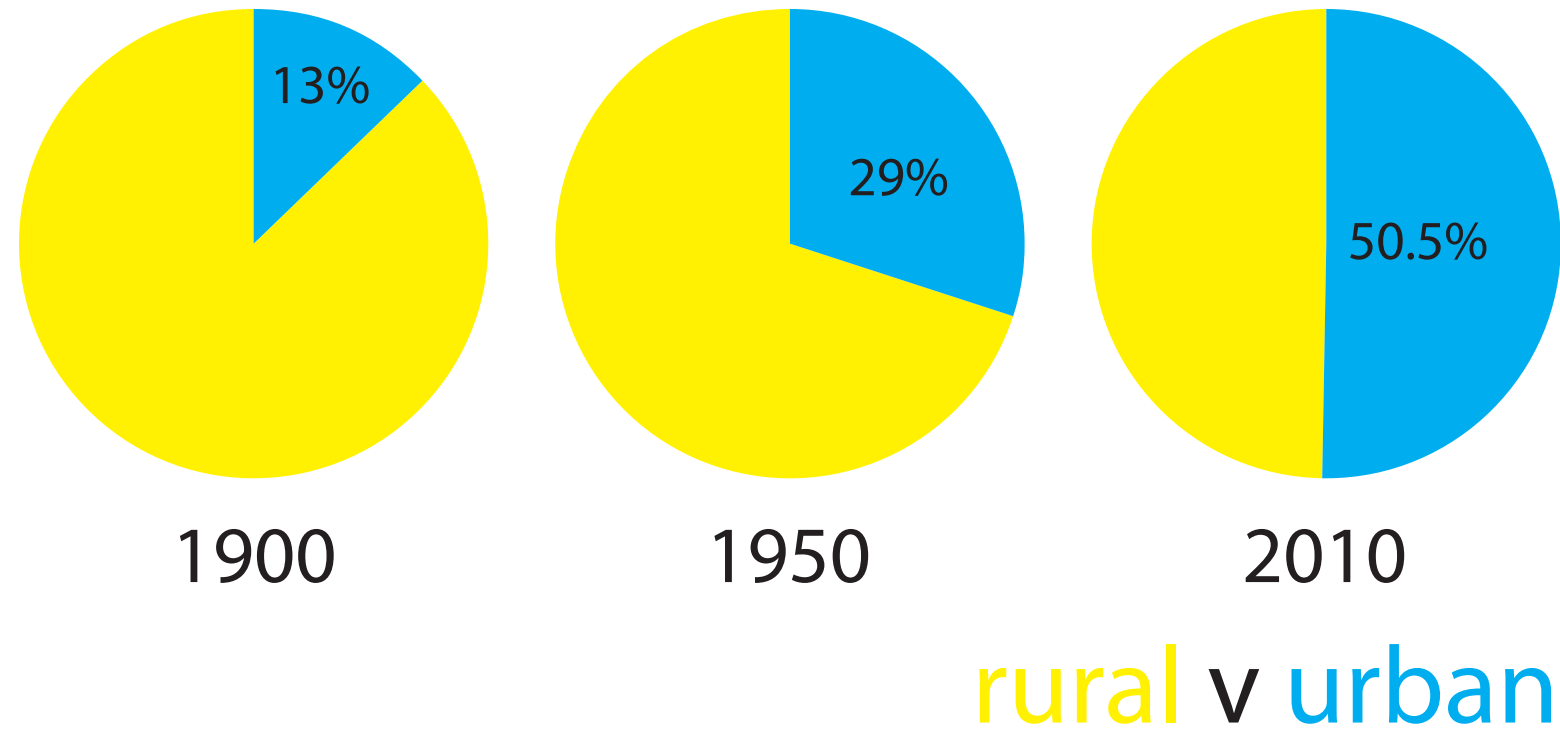

Figure 2. Global rural to urban population trends from 1900 to 2010.

As of 2010, more than half of the people living in the world reside in urban areas, compared to only 13 percent in 1900 (Fig. 2; United Nations 2005; World Health Organization 2012). And while there are many benefits that accompany an urban lifestyle (more sustainable, higher densities, easier access to cultural activities etc.), it also often results in a separation of people from the natural environment. Urban dwellers are at risk of losing a connection with nature that is not only beneficial but essential to their existence as human beings.

PROBLEM STATEMENT

Is it possible for architecture to help reconnect people with the natural world, the very thing that it was conceived to protect against? How can the built environment act as a mediator between humans and nature? How can the design amplify/distill/isolate all of those elements that tell one that they are in nature?

Rationale

People have always shared an intimate bond with the earth; it is the source for all that sustains them. This fact was very evident as humans shifted from hunter-gatherers to agriculturally based societies. The earth provided the substrate from which they garnered everything needed to survive and thrive. But as human society moved into the industrial age, some of that direct connection with nature was lost. As more and more people moved into cities, there were fewer and fewer people working the land and sustaining that direct connection with nature. And as farming became more industrial, the human-nature connection suffered even more.

This drifting apart reached a tipping point in the 1960's when the detrimental effects of pesticides like dichlorodiphenyltrichloroethane (DDT) were exposed. As industrial human's relationship with nature grew ever strained, groups emerged that were dedicated to the protection of the natural world and to opening people's eyes to how their actions were negatively impacting the world around them. These groups were instrumental in the adoption of important environmental legislation such as the Endangered Species Act of 1973 and the formation of government agencies such as the Environmental Protection Agency (EPA) in 1970. And although these actions were proposed as means to protect nature from people's

selfish actions, the people leading the charge were doing so because they understood that, in the end, they were actually protecting humans from themselves. It is this understanding, that humans are dependent on the earth and that what is bad for the earth is bad for humans, which is the driver behind the environmental movement. And it is the growing separation of humans from nature that resulted in people losing sight of this connection and doing irreparable damage to the environment.

In order for people to reconnect with nature they must get back into a mindset where they understand how intimately tied to the earth they are. And in order for one to start to understand this, they must surround themselves in nature. It is not enough to take a Sunday stroll through the park, one needs to feel they are removed from the comforts of society, where seeing a bear is almost as likely as seeing another person. Just as a zoo is not equivalent habitat to a wild animal, people too need to feel the freedom and challenge of wilderness.

This exposure to nature not only helps people to better understand their world but it also helps them to understand themselves. The human spirit needs a connection to nature as much as the human body and just as one would hire a guide for a wilderness expedition for the body, the spirit too needs guidance. Just being in the presence of untamed nature can be exhilarating, this is what draws people to mountains and waterfalls but, in order for the experience to permeate beyond the confines of a picture frame, one needs to reflect on what these things mean. This need for reflection and focus is what will elevate the encounter from a vacation to a life changing experience.



Figure 3. Ladder Falls, Newhalem, WA.

Theoretical Framework

The modern English word nature comes from the Latin *natura*, which means “essential qualities, innate disposition”, literally translated: birth (as in pre-natal; Harper 2012). In modern English the word nature is used both to refer to the surrounding biological environment as well as a being or things innate qualities. The Latin root of the word along with its

dual meanings is evidence of how important it is to life. It is a word that encompasses the creation of life, all of those living things as well as how they are; what makes them unique, specific. Nature, in the sense of the living world, also plays a direct spiritual role in many religions, not unlike the role of god in modern monotheistic religions (Christianity, Islam, Judaism). So to live a life without nature, is to not only live without a place, but is to live without a defining essence, which gives life meaning. Nature sustains the soul as well as the body.

Nature is defined as “the phenomena of the physical world collectively, including plants, animals, the landscape, and other features and products of the earth” (Oxford University Press 2012). But how does one know when they are in the presence of nature? Is one leaf, floating on an endless sea of pavement, nature? Yes, in a singular, awakening moment of contrast but not in the sense of a sustaining force. This is the challenge of urban living. One can’t fully experience nature unless they are immersed in it. To bask in the glory of nature is to feel its immensity and power and to understand how minute one is, but at that moment realizing that they are, in fact, a part of nature. To be in nature is to experience that sensorial awakening. One sees the trees towering above, one feels the sunlight as it warms their skin, one hears the water as it cascades down the creek and one smells the sweet sage on the breeze. Each of the senses plays an integral part in experiencing nature, the result of all of the senses being stimulated tells the body and mind where it is and consequently a feeling arises in response to the stimuli.

The physical context of a project plays a very important part in its formation because at the most basic level, the building is directly connected to the site. But ideally, a well-

designed building will foster a much deeper connection with its site than just occupying it. In addition to the given cultural factors, a building should be designed as a response to the external factors at work on a site and should ultimately use its surroundings for inspiration so that the site and building create a synergistic relationship. Interpreting and understanding a site is essential to a conscientious and responsible design intervention. Buildings should respond to a specific site and use the elements of that site to produce an outcome which improves upon the area as a whole.

Phenomenology is defined as “an approach that concentrates on the study of consciousness and the objects of direct experience” (Oxford University Press 2012). In architecture phenomenology explores how one experiences a building through direct sensorial interaction or bodily consciousness. The aspects of the building that can be considered stimuli include materials, the use of light, spatial composition, transparency. The manipulation of each of these elements by the architect is what ultimately defines the design. Pieces can be designed to complement or contrast, to create harmony or discord. With each shift, the experience of the place is created and defined. This sense of place is most often described in religious or spiritual buildings where the design is meant to expand the occupant’s awareness beyond their day to day lives.

The power of sensorial richness and variety has been discussed in the context of experiencing nature, but there is also strength in isolating a sensory experience. When one meditates, the goal of the exercise is to release oneself from everyday life. One method used in the practice of meditation is chanting, where a single syllable, word or phrase is repeated, so that one’s thoughts are focused on nothing but the chant. The goal of these exercises is

feel the sunlight
as it warms
your skin,
see the trees
towering above,
hear the water
as it cascades
down the creek,
smell the sweet
sage on the
breeze.

to clear the mind and open up to a greater consciousness. Similar results can be achieved a number of ways: through visualization, breathing exercises or repetitive movements, but the one thing that most of these techniques share is that they train the participants' attention on one thing and one thing only.



Figure 4. Clouds on the Cascade Mountains.

LITERATURE REVIEW

The roots of phenomenology come out of the idea that life, thought, building and dwelling are all interconnected and all essential aspects of human life. There is also a strong connection between the built thing and the location of the thing. In essence, one cannot exist without the other. These ideas began to explore what it meant to be human and to have the power of creation and how the things that man created became not only part of his world but also a part of him (Heidegger 1971).

Phenomenology starts to take a more concrete form when it is directly applied to the realm of architecture. The term “genius loci” refers to the spirit of a place and phenomenology looks at how architecture exists as an interpretation of the genius loci of a specific place (Norberg-Schulz 1980). Therefore the relationship between a specific building and its specific place is such that the same building could exist nowhere else. And man's place in this union is to translate the place into the building, which then acts as a tool to in turn bring man closer to the place. Norberg-Schulz also describes three basic landscapes: classical, cosmic and romantic, each of which has distinct characteristics that can also be seen in architecture of those landscapes.

Just as man has been described as the translator between a place and the resultant local building, architecture in turn takes on a similar role in the case of sacred spaces. In a sacred space the built environment is designed to be the mediator between man and the higher power for which the building was designed (Barrie 2010). Barrie also discusses religion's role in bringing people together and creating a cohesive group, which early on was very place specific, echoing the importance of place on religion and in turn it's sacred buildings.



Figure 5. Skagit River west of Diablo, WA.

This idea of architecture being born of a place is further explored in *Nightlands*. Here the idea of genius loci is discussed on a national level using Denmark, Finland, Norway and Sweden as examples. Norberg-Schulz shows that even within the Nordic region, there are many differences between the countries and that these differences can be traced back to the landscapes and natural qualities of each country (Norberg-Schulz 1996). The effect of foreign and international influences on a place's architecture is also discussed and underlines the appropriateness of building from the local genius loci.

Even before phenomenology was being defined as it is understood today, people were appreciating the specific nature of a place and questioning the outside world's effects on it. Tanizaki wrestles with his place in a Japan that is being more and more influenced by the western world and describes the challenges of preserving the spirit of a traditional Japanese house, while trying to integrate some modern conveniences. He also discusses the presentation of food and even women, all of these things run the risk of losing that little bit of softness and mystery which he cherishes. He fears so much will be lost that is essentially Japanese with the harsh scouring lights of the western world (Tanizaki 1977).

The sensorial element of architecture is often overlooked or dominated by a single sense. Pallasmaa describes the "ocularcentric paradigm" of western culture and how it has, in essence, robbed architecture of its depth as a place and an experience. He discusses the value of all of the things that we can not necessarily see and argues that without them we are left with flat lifeless spaces (Pallasmaa 2005). Just as Tanizaki before him, Pallasmaa pleads for an understanding of the importance of a place, an understanding that includes touch, sound, smell and even taste.

Looking more closely at the tactile sense, one discovers that, beyond texture, there is also the question of temperature. The importance of the thermal environment is one that is very basic in architecture, but is usually discussed in terms of comfort; heating and cooling a space to make it inhabitable. But if we look at temperature from a different perspective, it can be considered as a very important sensory experience outside of necessity. *Thermal Delight in Architecture* discusses how thermal elements such as the hearth, sauna or bath create an entity which provides its users with more than just heat on a cold day; they become an extremely important place (Heschong 1979).

The basis for understanding architecture through the lens of the senses is based in how humans experience the natural world. Being out in nature, every sense is stimulated, this interaction with all of one's senses results in a heightened experience as the individual senses reinforce each other (Holl et al. 1994). It is in this way that architecture seeks to act like nature and create spaces where human existence is mediated and reconciled.

This idea of a sense of place is based on man's perception of his surroundings. As Norberg-Schulz has shown, a landscape has impacts on the buildings which inhabit it, but if a more evolutionary approach is taken to examining man's place in the natural world, one starts to see how it too impacts the way buildings are designed. The terms prospect and refuge are tied to the theory that, as man evolved, he had need for two types of surroundings, one that provided protection (refuge) and one where he could survey his surroundings (prospect; Hildebrand 1999). These two types of spaces can be seen in the built environment between say a bedroom which is typically more private and away from the central part of a house and a living room with a large window that is more of a hub for the daily activi-

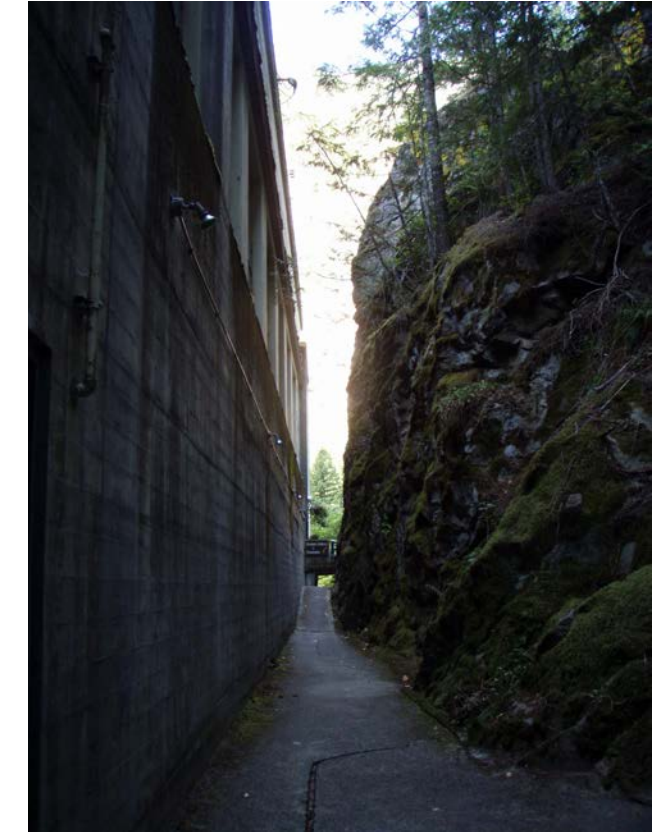

Figure 6. Gorge power plant, Newhalem, WA.

ties of the house. Each of these two types of spaces has specific qualities, which gives one a very different feeling from the other.

This sense of place, when viewed through more a biological lens, also has implications beyond the built environment. Looking at a closer scale, each country contains bioregions where the flora, fauna, geology, soil, topography and climate create distinct sub-units which implicate different ways of living (Coates 1981). These local conditions dictate many aspects of the inhabitant's life, from what types of food are available to what type of clothing is necessary and creates cultural commonalities.

America has always had a very unique relationship with nature. It stems in part from the colonial beginnings of the country, but is also influenced by the European legacy from which it came. To the early European settlers, North America was seen as an empty continent (Borgmann 1984). To them it was wild, dangerous and terrifying, a beast that needed to be tamed. The nature of America was in stark contrast to the cultivated, manicured gardens that symbolized nature in Europe. So they set to task subjugating the nature of the new world and exploiting it and its native people.

This early American attitude towards nature has been attributed to Christian ideals, which likened the new world to a "new Eden" (Mugerauer 1995). The settlers were viewing this raw landscape as a canvas to be molded into a Christian vision of paradise. Ironically, as differing views arose about conservation and stewardship, the areas of unspoiled wilderness were also conceived of as gardens of Eden

In the 1800's a growing movement started to congeal that viewed nature in a new light. One of the major milestones of this young movement was the publication of *Nature*



Figure 7. View of Diablo lake from the east.

by Ralph Waldo Emerson in 1836. Emerson talks about nature not as an opponent of man but rather as the food which sustains the spirit of man. Without nature man is incomplete and is unable to understand himself and his world (Emerson 1836).

Henry David Thoreau was another important figure in the evolution of America's relationship with nature. *Walden* was his treatise on nature and man, documenting his time

living in a cabin he built himself, on land owned by Emerson. Thoreau describes the importance of nature and wildness (Thoreau 1854):

“Our village life would stagnate if it were not for the unexplored forests and meadows which surround it. We need the tonic of wildness — to wade sometimes in marshes where the bittern and the meadow-hen lurk, and hear the booming of the snipe; to smell the whispering sedge where only some wilder and more solitary fowl builds her nest, and the mink crawls with its belly close to the ground. At the same time that we are earnest to explore and learn all things, we require that all things be mysterious and unexplorable, that land and sea be infinitely wild, unsurveyed and unfathomed by us because unfathomable. We can never have enough of nature.”

This understanding of man’s intimate connection to nature also came to the surface again in the latter half of the 20th century. Studying nature has been described as a meditation of sorts where one starts to understand the interconnectedness of life on multiple scales at once (Wilson 1984). But in order for one to get to a point where man is understood as a part of nature one must first be open to the possibility.

The discoveries of the solar centric universe, the structure of celestial movements and evolution all helped man discover his place within his world. Science has also allowed man to harness fossil fuels, genetically modify organisms and otherwise recklessly exploit nature for our singular desires. Science has played an integral part in helping man to better understand his natural surroundings, but in an ironic twist these technological advances have also become a means for separating humans from that same natural world (Crowe 1995). So in some ways, by replacing a world view based on myths and phenomena, the logic of science has limited man’s understanding of his place in the natural world.

The relationship of man to nature is somewhat innate, but it can be repressed and essentially lost if it is not nurtured. It seems that nurturing this relationship throughout one’s lifetime, just by exposure to the natural world, can play an important part in understanding one’s place in the world (Carson 1965). Carson describes the importance of being receptive to the pieces of the natural world and how important learning to use one’s senses is in the process of discovery, much like the way Pallasmaa describes the importance of sense in the built environment.

There have also been numerous studies conducted that have found significant evidence supporting the importance of people having direct contact with nature. Many modern careers are based on specialization, this specialization may improve efficiency in limiting the number of tasks one must learn, but it can also result in mental fatigue and boredom. This prolonged focus has been shown to negatively affect work performance, but exposure to natural settings was found to restore mental capabilities (Kaplan 1995). Exposure to nature has also been shown to significantly reduce levels of stress (Ulrich et al. 1991).

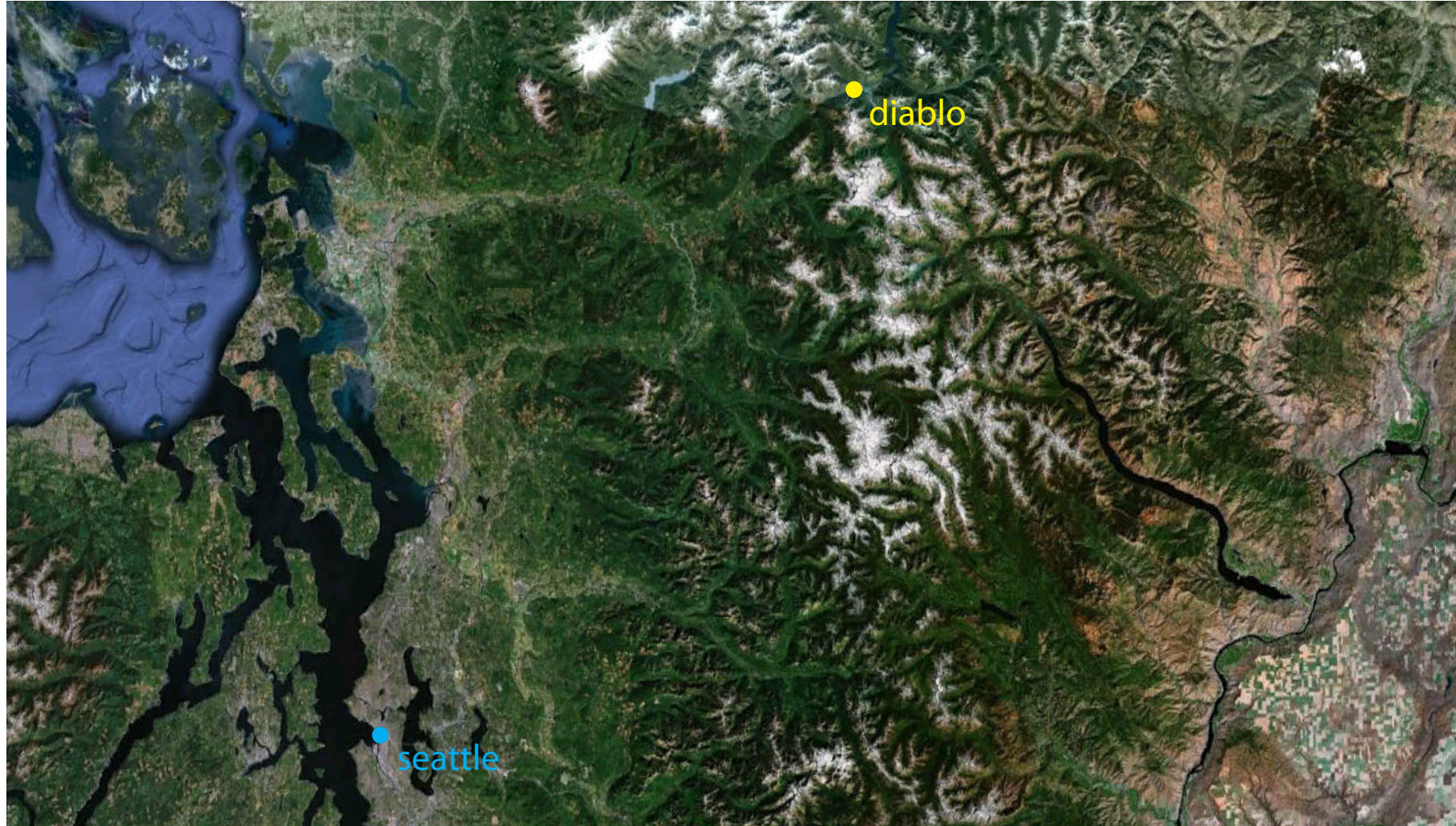

Figure 8. Aerial photograph showing relative locations of Seattle and Diablo, WA.

SITE

Background

The site for the project is near Diablo, Washington, USA (48.714, -121.136; Fig. 8). The Diablo Dam stretches across the canyon, stopping the flow of the Skagit River and thereby creating Diablo Lake on the eastern side of the dam (Fig. 9). The lake is renowned for its turquoise waters, which are a result of the suspended minerals that flow down in the glacial melt.

The North Cascades National Park (NCNP; Fig. 10) is the second least visited national park in the lower 48 states (Ramos 2011). It was established in 1968 in response to increased pressures from clear-cut logging, mining operations and motorized recreation. The park includes almost 700,000 acres of the Cascade Mountains of Washington state, from the Canadian border, south to Lake Chelan. The park contains the greatest concentration of glaciers in a national park outside of Alaska and is also home to threatened and endangered species like wolves and grizzly bears.

The NCNP is bisected by the North Cascades Highway (SR20), which runs east-west across the Cascades usually running along the Skagit River. The area of the park that immediately encompasses the highway is designated as the Ross Lake National Recreation Area (RLNRA; Fig. 11). The RLNRA is 117,000 acres of the park complex that includes the areas surrounding Ross Lake and the Skagit River. Ross Lake, Gorge Lake and Diablo Lake also are found within the RLNRA. All three lakes were created by dams erected along the Skagit River that are operated by Seattle City Light (SCL).



Figure 9. Aerial Photograph of Diablo Dam (N^).

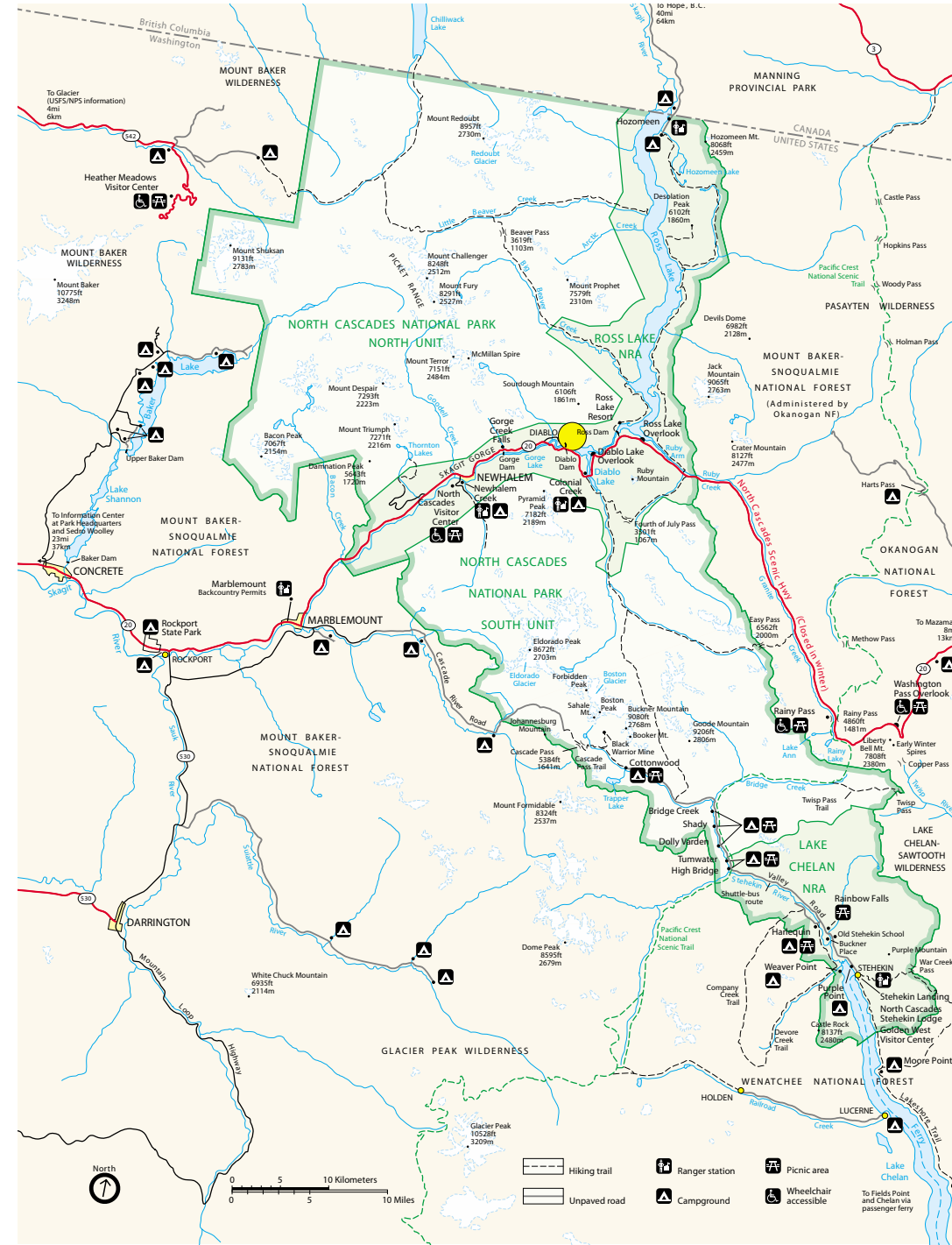

Figure 10. Map of North Cascades National Park with Diablo highlighted.

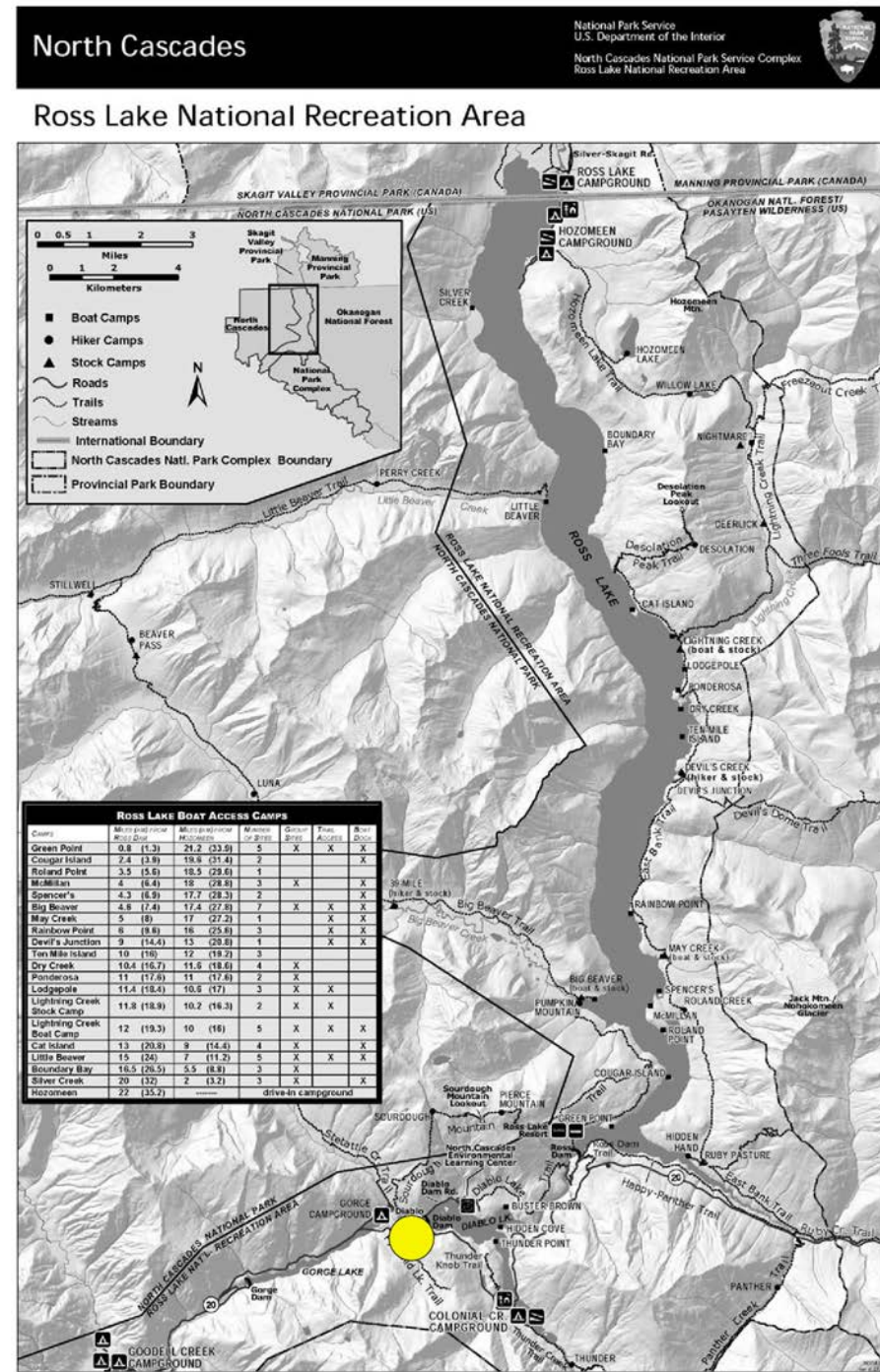

Figure 11. Map of Ross Lake National Recreation Area with Diablo highlighted.

The high rugged peaks of the North Cascades fall sharply into valleys that have been eroded away over time by the glacial melt that feeds the rivers and streams. Due to the changes in elevation, soil types and precipitation across its range, the NCNP contains nine distinct ecoregions (Fig. 12; EPA 2010). They range from a dry continental climate in the east, to mild, maritime, rainforests in the west. Most of the RLNRA can be classified as North Cascades Lowland Forest, which are “composed of low mountains, broad glaciated valleys, and glacial-fed rivers that receive, on average, 60 to 90 inches of precipitation per year. Extensive, productive rainforests have developed under the mild maritime climate and are dominated by western hemlock, Douglas-fir, and western red cedar” (EPA 2010).

Forming the spine of the RLNRA is the Skagit River; the Skagit is one of the longest rivers in Washington State and supports populations of native salmon and trout (US Forest Service 2012). The river is also home to three SCL dams: Ross, Diablo and Gorge, collectively known as the Skagit River Hydroelectric Project (Fig. 13). The river was attractive to SCL because, as it flows from the Canadian border down to Newhalem, the elevation change is over 1000 feet. The steep narrow gorges formed by the flowing Skagit also provided sites optimal for damming the river.

The Skagit River gets its name from the Skagit Tribe; they were the original inhabitants of the area along the river. Outside interest in the area of the NCNP started in the late 1800’s with the discovery of gold, before then the area was mostly unknown and untapped because the steep rugged terrain prevented most travel and made the prospect of logging too difficult. The extreme climate and terrain also limited the ability to establish agriculture on any appreciable scale. But with the discovery of gold people’s desires overshadowed the

dangers and difficulties of traversing the North Cascades. However, this boom was short lived and effectively over by the early 1900's, with little to show for the efforts. By that point most people hoping to strike it rich had moved on to Alaska. The establishment of company mining towns did however work to shape the future of the Skagit today by establishing the area's potential for hydro-power, which was used to create electricity in some of the towns.

In 1905, after seeing the possibilities for hydro-power in the area and wanting to monopolize on the opportunity, the Skagit Power Company was formed with an initial investment of \$1 million. Unfortunately, for its founders, the prospect of building a dam on the upper Skagit proved too difficult and financially unfeasible and the company was sold to Stone and Webster. However, Stone and Webster too found the job to be too much and the idea of a dam on the Skagit never came to fruition, this however didn't stop Stone and Webster from buying up the rights to build on almost every possible site in the area. Finally in 1917, after Stone and Webster's Skagit permits expired a second time, the door was opened for SCL.

Seattle City Light was awarded the rights to build dams on the Skagit River for hydro-power in December of 1917. But because SCL was a public owned company, there was a fair amount of skepticism from the citizens of Seattle that SCL would run the city deep into debt by undertaking a project that had been too difficult and expensive for two previous attempts already. James Ross, SCL's superintendent, however was up for the challenge and convinced the mayor and the city council that the project would be a success.

In 1918 construction began on the Gorge Creek project. Along with the dam itself a railroad was also constructed to move people, machinery and goods to the construction site. As the project progressed another issue arose, where were the workers going to live? Seattle City Light addressed the issue by building 75 cottages, 6 bunkhouses as well as a cookhouse and warehouse on the flat just below the powerhouse. By 1921 the site grew to 1,000 residents and was called Newhalem. Finally in 1924 the Gorge project was completed and the first electricity from the Skagit ran to Seattle.

Construction on the Diablo Dam (Fig. 14 & 15) site began in 1927. Diablo, about 5 miles up the Skagit from the Gorge project, was seen as the best site for the next dam, which would allow SCL to better control power production at the Gorge project and would allow them to use a barge to get supplies and materials to the proposed site of the Ruby Dam, where extending the railroad was not feasible. Even though the Diablo Dam was dedicated in 1930 the Diablo project was not fully up and running until 1937.

The final piece of the Skagit Hydroelectric Project, Ruby Dam, was started in 1937. During its construction, in 1939, James Ross died; the project was renamed after the long-time SCL superintendent who had finally been the one to realize the dream of harnessing the power of the Skagit. Ross Dam and power house were not fully functional until 1954. Finally in 1958 SCL started work to replace the Gorge Dam with a high concrete dam, which was completed in 1961 (Pitzer 2001).

Analysis

The site was selected due to the wealth of natural resources present in the NCNP but also because of the relative remoteness. However, being remote was not in itself a determining factor because, without some reasonable means of access, the center would not be able to perform its primary goal of helping people reconnect with nature. The location of the center needed to be remote but accessible. The adjacency of SR20 provides ample access, while the location of the park in the mountain range ensured that it is far from well traveled. The town of Diablo is about a 2.5 hour drive from Seattle, making it an easy commute from a large urban center. Close proximity to the town of Diablo also allows for a near by area for visitors to leave there cars without creating more disturbance. There is also a seasonal element that comes into play when discussing access. Every winter the section of SR20 between Diablo and Mazama is closed from approximately November to May due to the high amounts of snow, limiting its access even further. This seasonal closure will also be respected by this project, limiting the center's open time to when SR20 is open, which is consequently when most people visit the area.

Balancing between contrasts also came into play when deciding to site the project in the RLNRA. This area, along the Skagit River, allows for easy access to the expansive wilderness of the NCNP but contains the human disturbances within its borders, allowing the park to remain wild. This is not only important to maintaining nature but also allows the discussion of man and nature to continue up to the edge of the park. The site of Diablo is interesting in this respect because, as one moves along the continuum from the urban to the natural, one would expect that at each extreme the dominating element would over power

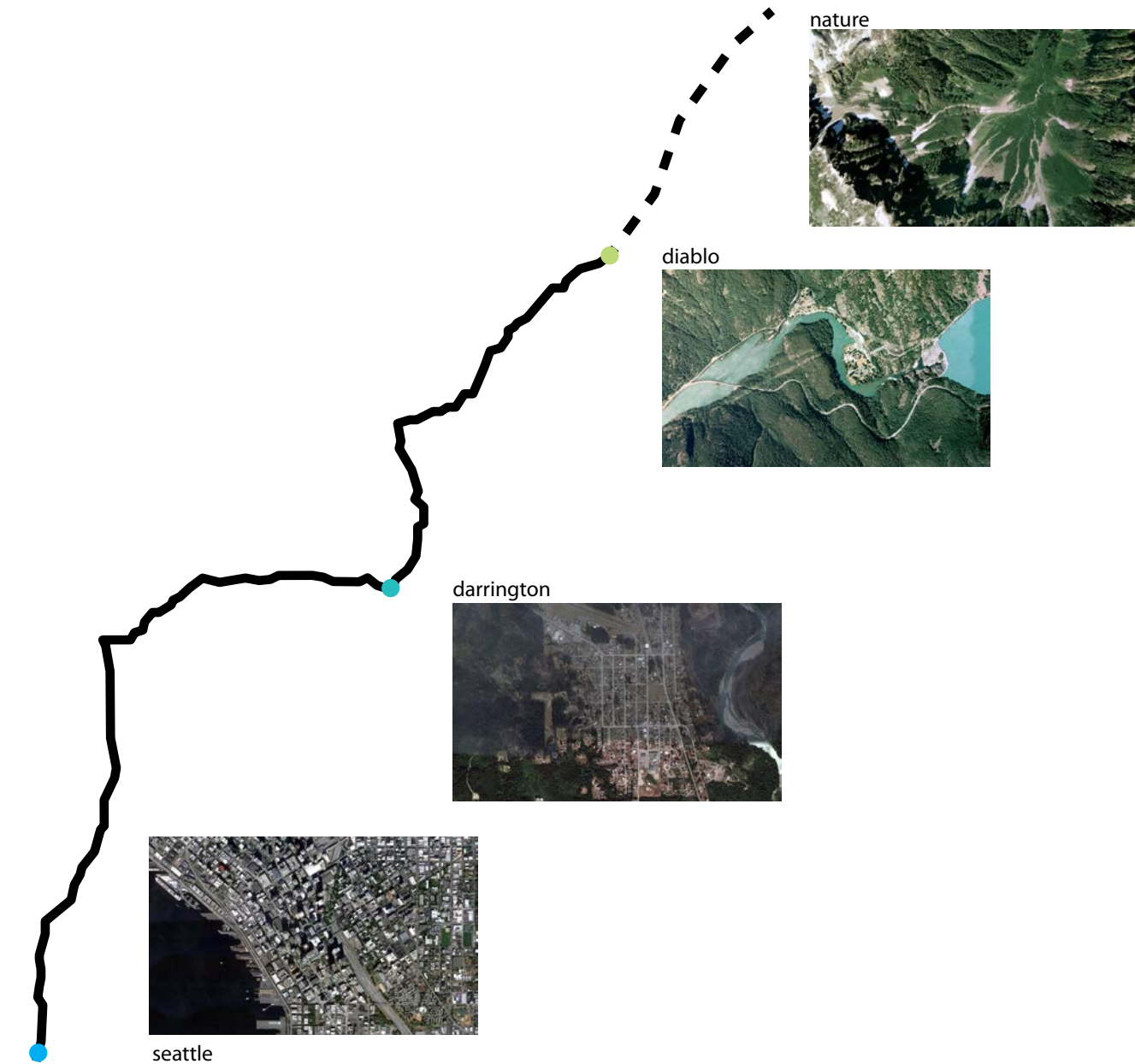
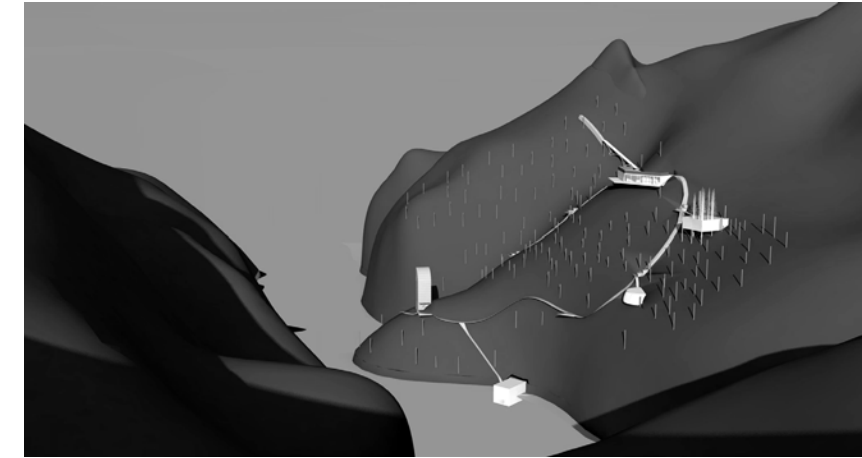

Figure 16. Nature continuum from Seattle to NCNP.

and dwarf the lesser element, but in Diablo it seems that the man-made elements also take a position of power (Fig 16). Even though one is surrounded by the natural, the grandeur of the dam is an overpowering spectacle that confronts its assumed place as a tiny man made token in this nature dominated area.

The area of the RLNRA, being in the valley carved by the Skagit River, also allows a greater amount of access to the distinct natural elements, which are the basis for the meditation spaces (ie tree, sun, water & wind). The valley not only channels the waters of the river, but also acts as a funnel for the winds that run through the area. The slope of the valley sides also allow for there to be trees, but a light limiting canopy does not develop like it does on flatter, forested ground, this allows there to be access to sunlight as well. The access to sunlight is a large consideration in a valley, which ultimately led to the site being located on the northern side of the river (Fig. 17 & 18). The topography of the site also affected the placement of the center. Patterns of projection and retraction become apparent along the north side of the valley below Diablo Dam (Fig. 19). These differing land forms provided opportunities to locate elements in different locations due to their programmatic needs and allowed the natural landforms to be used as points of separation. These moves in the topography are also apparent in the rivers edge. Along the river there are areas of straight free-flowing channels, which correspond to the projections in the land, and areas where the river widens and the flow slows, creating pools where the retractions in the landscape exist (Fig 19).



may 1st - 7am



may 1st - 4pm

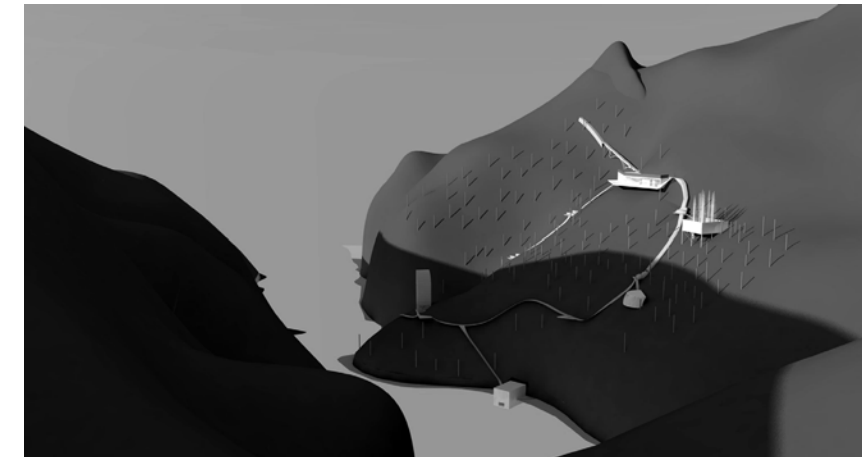

nov 1st - 10am

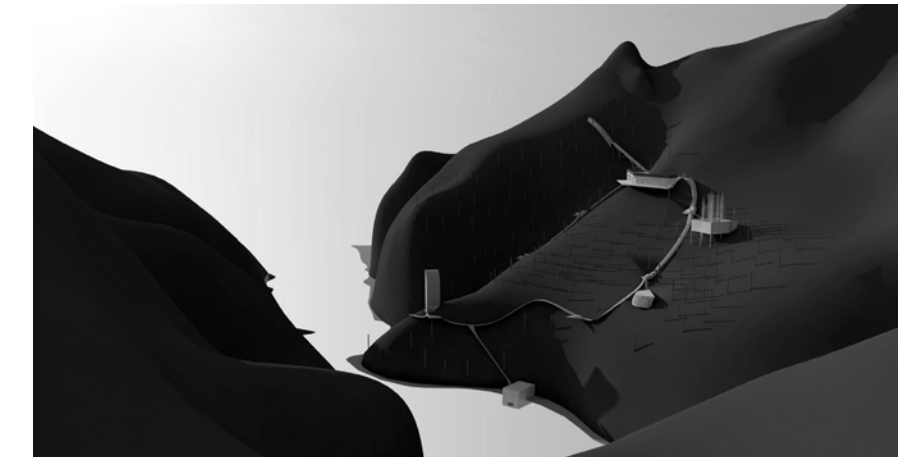

nov 1st - 3pm

Figure 17. Views showing shading on site at beginning and end of open season.



nov 4th - 12pm

Figure 18. Photograph of mountain shadow on Diablo Dam.

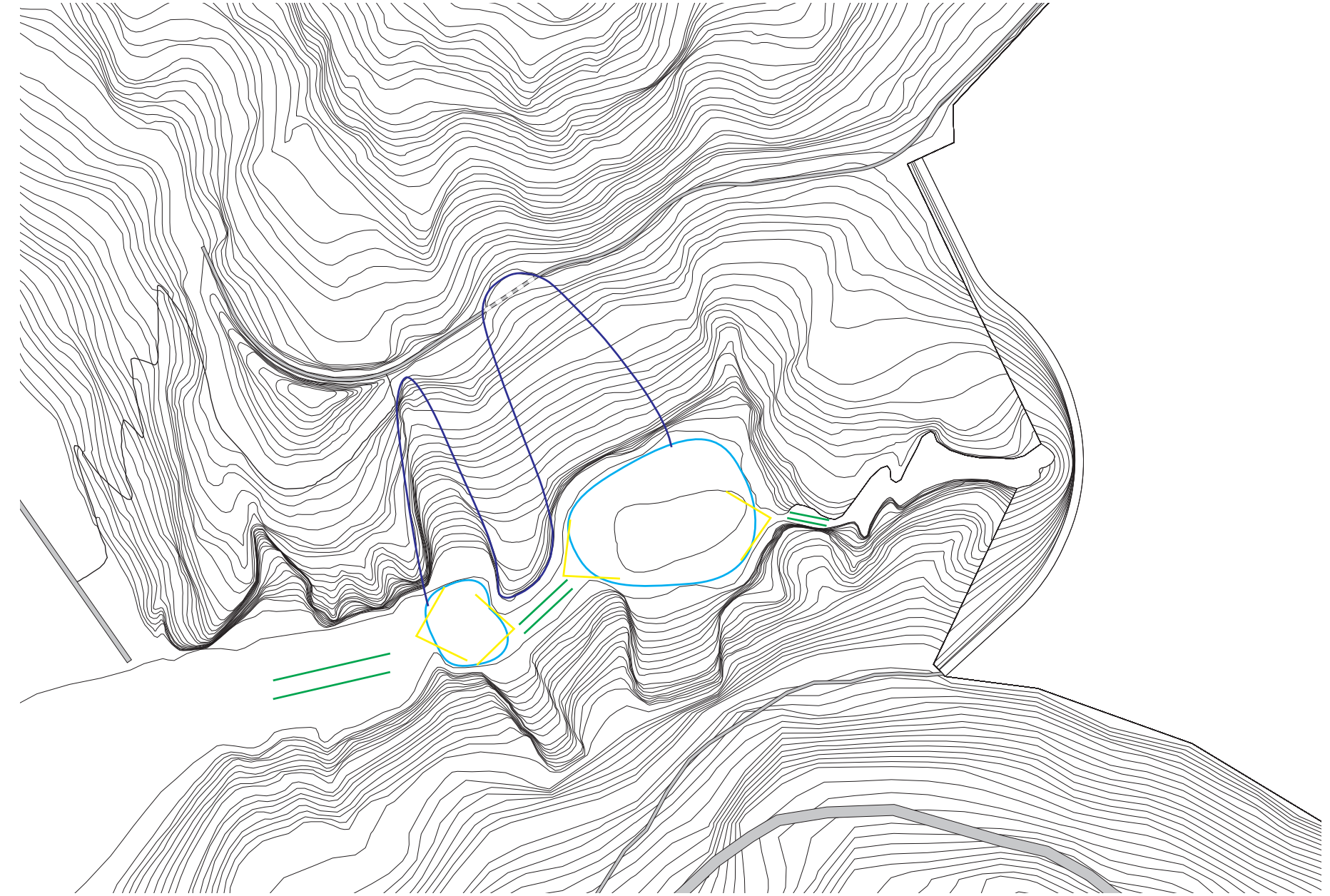

Figure 19. Topographic features and river flow of site.



Figure 20. North Cascades Institute's Environmental Learning Center.

DESIGN

Program

As a part of their lease renewal agreement, Seattle City Light undertook a partnership with the National Park Service to construct the North Cascades Institute's Environmental Learning Center (NCIELC; Fig. 20). The NCIELC is located on the north shore of Diablo Lake, west of the Diablo Dam. Their programs center on interpretive, environmental education but little emphasis is given to the more spiritual side of the man-nature relationship. There is a need for more spiritually based programs that focus on reconnecting people with the natural world. These programs are necessary if man is to rediscover his place as a part of nature, as opposed to its opposition. The Nature Retreat and Meditation Center is conceived as a way to enhance the range of programs available to the public while fostering the shared vision of increasing people's awareness of their natural surroundings.

The North Cascades Nature Retreat and Meditation Center is conceived as a place for city dwellers to spend a week or two away from the stress and strain of their daily lives. The setting provides the guests an opportunity to reconnect with nature and focus on a piece of their spiritual life that is neglected in the urban setting. The guests are encouraged to explore the center and surroundings in silence and attempt to hear what is normally drowned out by everyday life. The experience is meant to go beyond the simple "take only pictures, leave only footprints" approach that typifies the average nature experience, into a realm where the participant is reacting to their experiences and is forced to examine their relationship with the natural world. The rigor of this journey is one which requires guidance and

expertise in order to ensure that the participants leave with a renewed sense of their place in the nature continuum.

The most important parts of center are the four meditation areas (tree, sun, water & wind). Each of these mediation areas is conceived of as a place where nature is distilled down into one of its basic elements. The areas are meant to provide a point of focus for the inhabitants, to guide their meditations. These areas provide the basis for the meditative practices which are central to the center's mission.

The other parts of the center are conceived of as support for the meditation areas. The center includes overnight accommodations for 12 guests, as well as rest-room facilities, a kitchen and communal dining area. In addition to the accommodations for the guests there is also a one bedroom, one bathroom apartment for the full-time facilitator.

Concept

The project arose out of this idea that man needs to reconnect with nature, which resulted in a exploration about how architecture can facilitate the reestablishment of man as a part of nature. The main instruments in this spiritual detour are the meditation spaces, which are each designed to accommodate up to 5 or 6 people at a time. They are conceived of as points of departure from the average experience of nature, a way to mediate between man and nature. Each meditation space is dedicated to a single element of the natural realm: tree, sun, water & wind and within these spaces the architecture is designed to amplify the single element, while blocking out all of the rest of the sensory input present in the natural surroundings. The idea is that the inhabitant of the space is forced to focus their attention on that single element and all of the sensory stimuli that can accompany a single element. In

this way the spaces are operating like a yogi giving a student a single word to chant as they meditate, one is allowed to focus on one's direct interaction with the element of the space and reflect on how that one element can be used to establish one's place in the natural world.

The Tree Space puts one amongst the trees, as if it no longer matters whether the vertical forms of the space are trees or people, the light and views are controlled, but your proximity to the trees allows one to hear the creaking of branches, smell the scent of needles, touch the bark, taste the sap and see yourself as a part of the forest (Fig. 21). The Sun Space isolates one from the visual surroundings so that the light itself becomes the focus, one can see as the shaft of light traces across the floor, feel the heat of the sun as it warms the space, taste the sweat as it begin to bead, smell the warm earthen walls, hear the birds begin to sing as the sun rises (Fig. 22). The Water Space controls the light by only allowing it to enter through the water, emphasizing the focal element which one can see reflecting on the walls, smell in the moist air, hear as it laps against the stone, feel its cool as one enters the pool and taste as you submerge (Fig. 23). The Wind Space controls the light and views keeping the upper opening above the levels of the platforms, as one climbs to the platforms one can feel the breeze as it caresses the skin, taste the sweetness of the sage, see the fabric as it undulates, hear the rustling leaves and smell the cedars on the breeze (Fig. 24).

Journey

The experience of the journey begins in the town of Diablo where visitors will leave their cars. From there one ascends 300 feet from the river basin up the side of the valley via an existing trail that connects the town with the upper area of the dam (Fig. 25). This climb begins to prepare the visitors mind by exaggerating the initial separation from their



Figure 21. Tree Space concept model photograph.



Figure 22. Sun Space concept model photograph.



Figure 23. Water Space concept model photograph.



Figure 24. Wind Space concept model photograph.



Figure 25. Site plan.

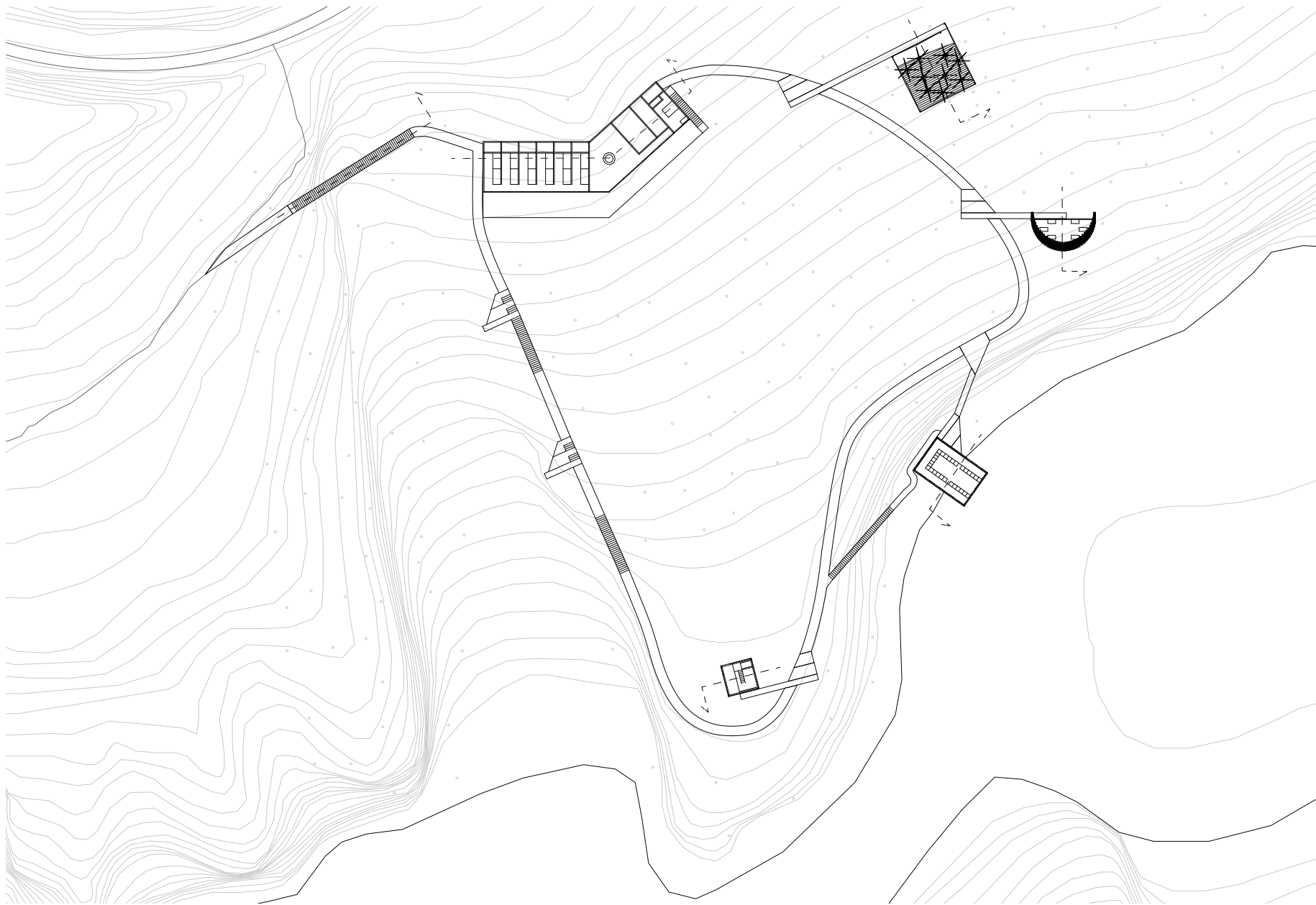

Figure 26. Plan.

day to day lives. It also sets the tone for the rest of the journey. The journey is meant to be a strenuous undertaking where every step must be deliberate and careful, if one is not fully focused on the task at hand, injury may occur. Along the path there are points of repose and reflection, where one can recover and reflect on the journey. The meditation spaces are meant as a calm contrast to the rigour of the path itself.

The detour begins at the fork in the trail, at the elevation of the dam but before the existing trail terminates into the road (Fig 26, 27 & 28). The first constructive feature of the designed path is the bridge that marks the separation of the existing site and the project (Fig. 29). The bridge spans the gully that serves as a natural boundary from the existing path. The bridge signifies one's entrance into the sacred place of the center.

From the bridge one continues down to the house which contains the sleeping quarters, dining area and facilitator's apartment (Fig. 30). The house is set into the valley side with the roof becoming part of the path. The sleeping quarters consist of 12 single person capsule sleeping chambers with four guests sharing a bathroom. Adjacent to the sleeping quarters is the outdoor platform where guests can choose to sleep when weather conditions permit. The dining area is where meals are served and functions as a utility room where yoga is also taught, there is also a small library. This central area of the house also contains the open-fire hearth. The southern facade of the house is a curtain wall which provides views out over the valley. In the middle of the house there are three large roll-up doors, which when open, allow the central space to extend out on to the exterior platform. Next to the dining area is the kitchen and separating the kitchen from the facilitator's apartment is the storage room. The small facilitator's apartment has a private bathroom and also func-

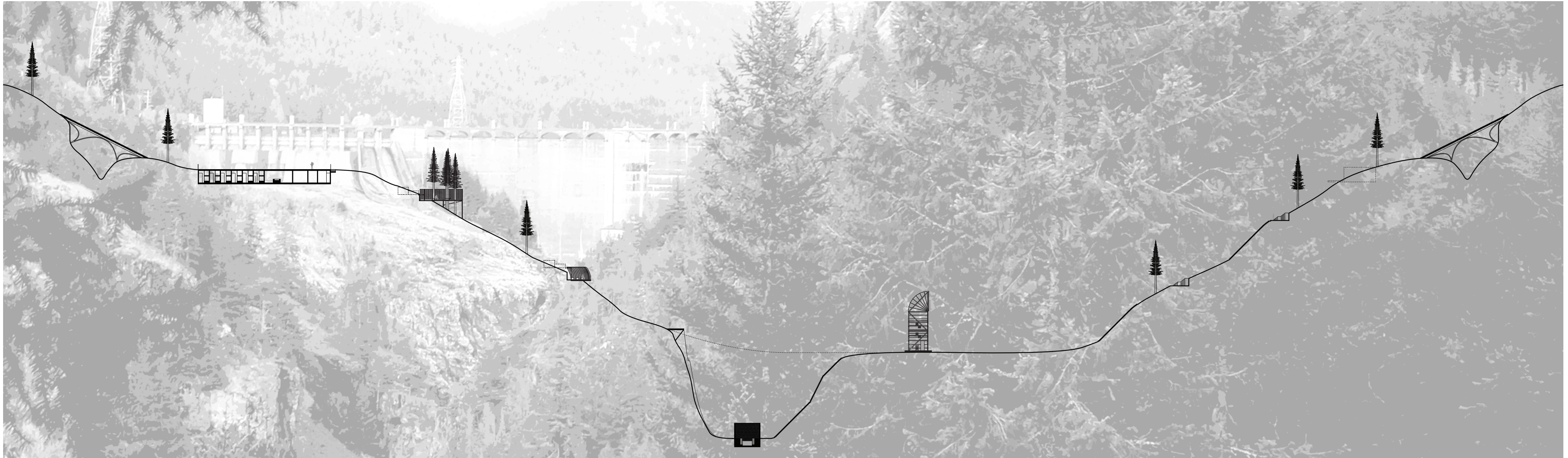

Figure 27. Unfolded section.



Figure 28. Bird's-eye view facing north-east.



Figure 29. View of bridge.

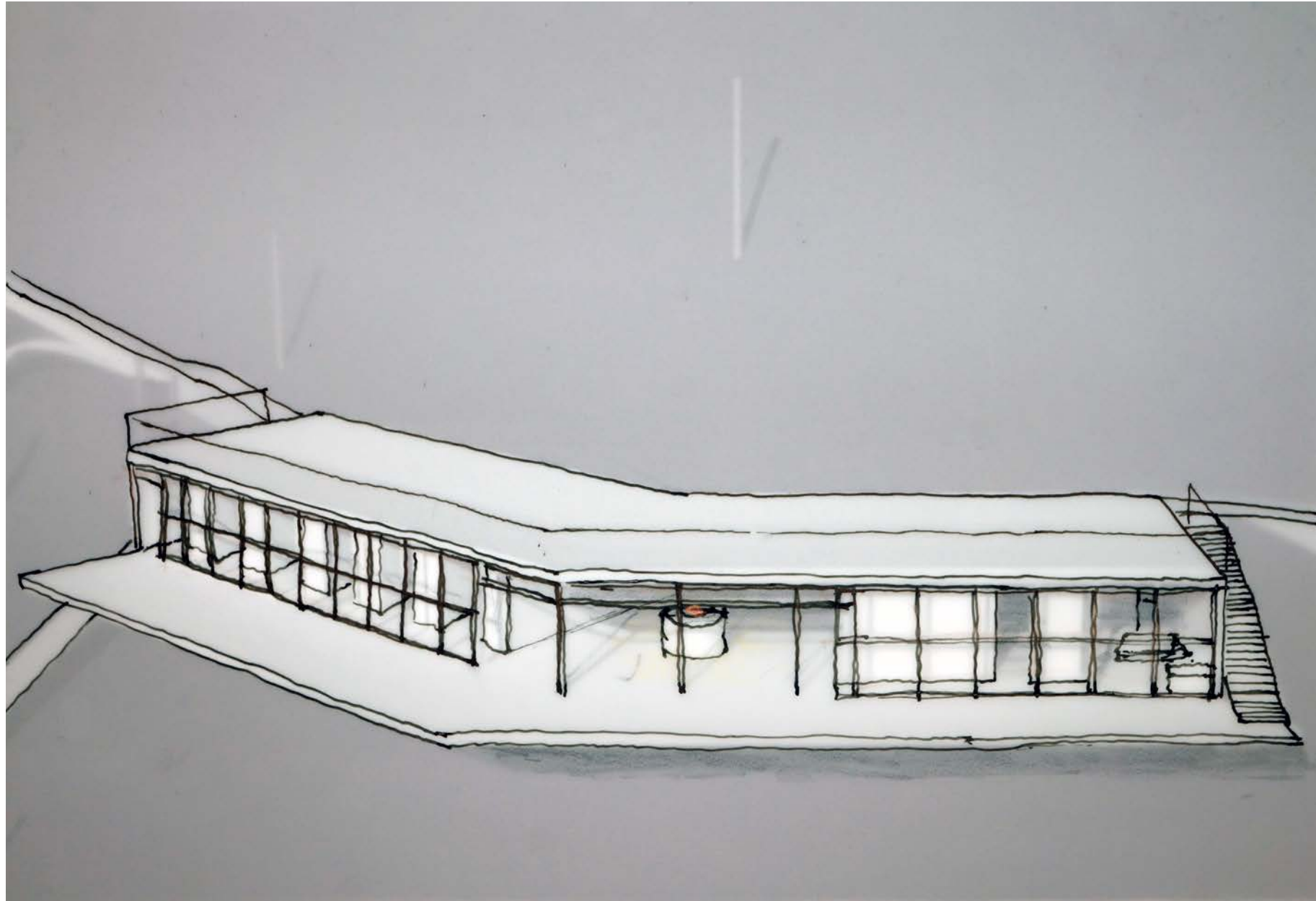

Figure 30. View of house.

tions as the office for the center. The house would be the first stop after the bridge, where guests would drop off their belongings and surrender to the facilitator any cell phones or other modern technologies that would interfere with their focus while at the center. The guests are then free to decide to go explore the surrounding park, recover from their journey to the center or continue on to the meditation spaces. Other than communal activities like eating or yoga the program of center is unstructured, one is allowed to explore and experience the meditation spaces in any order on their own time.

The nearest meditation space to the house is the Tree Space (Fig. 31). This space is conceived of as an open, light space and one that also speaks to the seasonality of the element. The Tree Space is constructed of red cedar lumber with red cedar decking. The boundaries of the space are constructed with shoji screens in red cedar frames. These paper screens are exposed to the elements and subsequently show the effect of this weathering (Fig. 35). The screens are allowed to naturally deteriorate, emphasizing the seasonal effects that also affect the foliage of deciduous trees, creating a cycle of death and rebirth throughout the course of a year. This seasonal cycle will be reflected in the screens where they will be allowed to degrade over the course of the year and replaced at the opening of the center each year. There is a small platform cut into the hillside at the edge of the area, this quickly becomes cedar decking as one enters. The trees in the space come up through the decking and are fitted with seats. As the platform of the deck remains at a constant level the hillside drops as it moves towards the river, this allows one to experience the trees along different levels of their trunk, from their base where they meet the earth to where the branches begin to radiate from the midsection of the trunk.

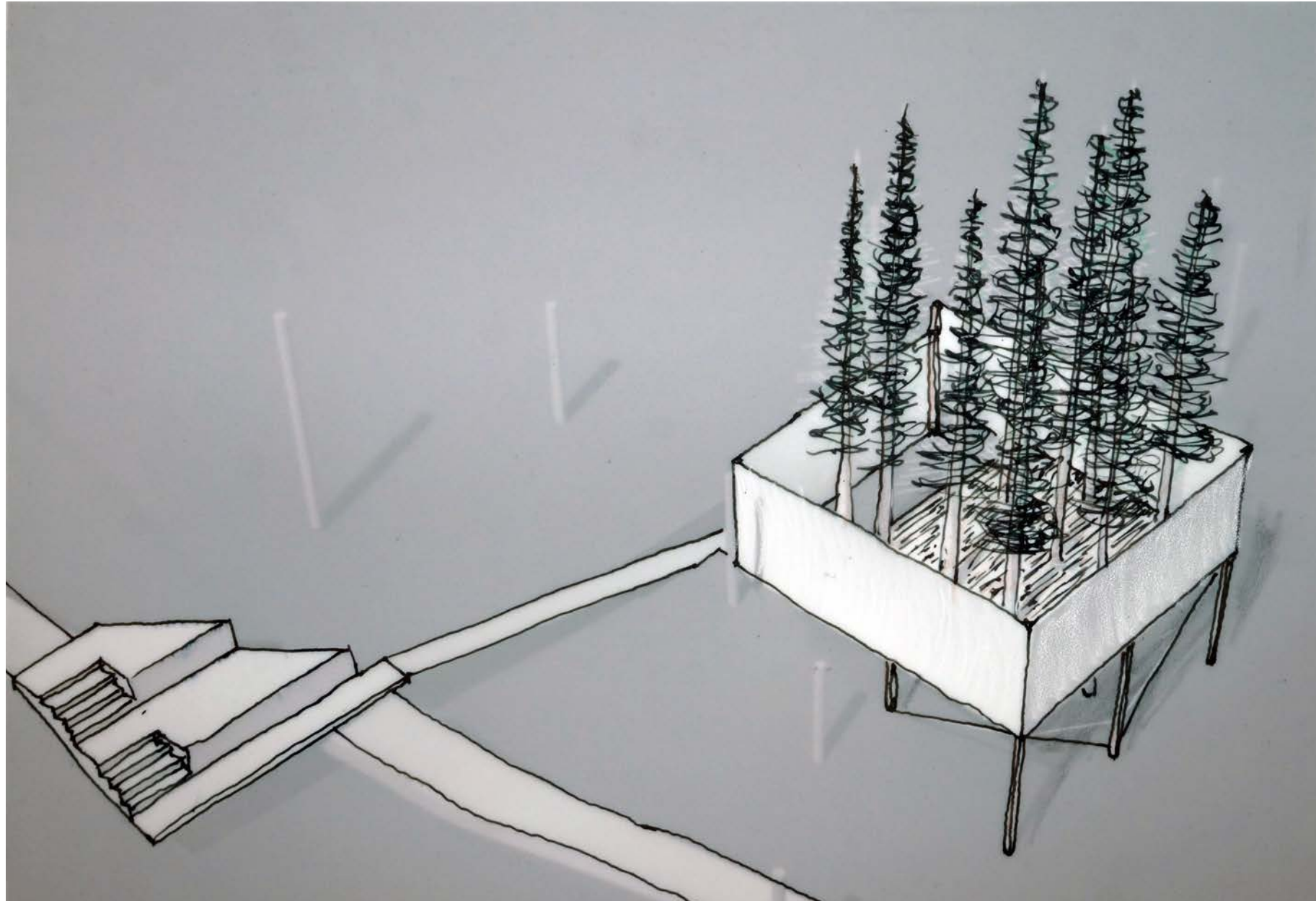

Figure 31. View of Tree Space.

The next point along the path is the Sun Space (Fig. 32). Unlike the Tree Space, the Sun Space is a more controlled environment, it is heavy with a rhythmic construction. This space is also set into the side of the valley in contrast to the Tree Space which is mostly built on top of the ground. The roof is made of red cedar lumber with a red cedar decking on top. The roof is supported by a rammed earth wall and a semi circle of soil composite CMU blocks. There is a vertical slot in the CMU portion of the wall where the light enters the space, otherwise the walls are solid, controlling the views and light. The polished concrete floor and benches are the substrate where the light is expressed. Because of its solid wall construction there is high contrast in this space, which is a generally dark space with the exception of the shaft of light through the opening in the CMU wall. The path of the shaft of light moves across the floor, exposing the temporality of sunlight and reflecting the changes in quality of light that occur throughout the day.

The next stop along the path is not a space but a point of decision. Between the Sun Space and the Water Space there is platform which looks out over one of the pools along the course of the river. From this platform one can choose to rappel down to the Water Space or continue along the ridge to the Wind Space. This point of descent marks the most strenuous point along the path because after repelling down to the Water Space the only way back up to the level of the main path is a very steep trail that leads from the Water Space to the Wind Space.

The Water Space is the lowest point along the path, the point where the journey reaches the river (Fig. 33). This relative position along the path is reflected in the construction of the space. The Water Space is a massive structure that is partially submerged in the



Figure 32. View of Sun Space.

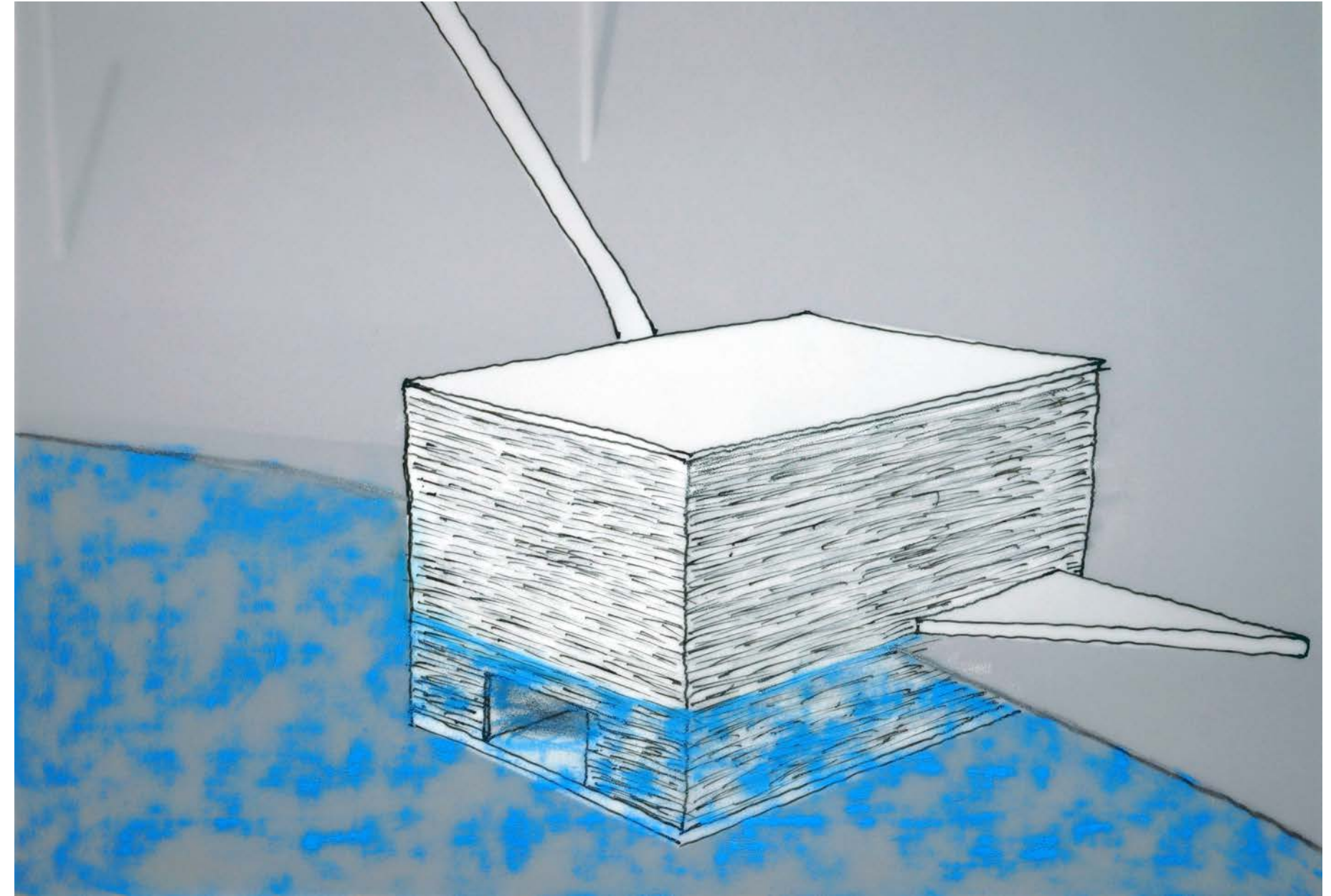

Figure 33. View of Water Space.

river. The materials of the space are hard and the only light source in the space comes in through an underwater opening, this opening is also the point where the water enters. The Water Space is also a very cool place due to its connection with the water and its control of light. The base of the Water Space is board-formed concrete which is overlaid with granite pavers, extracted from points in the site where cuts were made in the valley side. The large stepped ledges in the space allow one to decide how deep they want to venture into the experience of the water and can reflect any changes in the water level of the river. The granite stones that comprise the walls of the Water Space were also harvested from cuts in the site. The roof of the space is a precast concrete slab.

The Wind Space is the next point on the journey (Fig. 34). It is constructed of a red cedar lumber frame anchored to a poured concrete slab, with canvas-covered plywood platforms spanning between the cedar frame. The exterior of the space is made of white translucent sailcloth. Like the Tree Space, the Wind Space is a relatively light structure and also has a seasonal component. The sailcloth exterior is raised at the opening of the center each year and taken down when winter comes, this leaves the structure and platforms exposed, acting as the shadow of the space when the center is not open. The sailcloth controls the light and views but also moves in response to the wind. The Wind Space is the only space where one ascends within the space. This vertical movement also acts to further isolate the inhabitants of the space from each other as none of the meditation platforms is at the same level within the space.

From the wind space one can continue up the side of the valley returning to the house. Along the rather steep incline, there are two terraces for resting & reflecting during

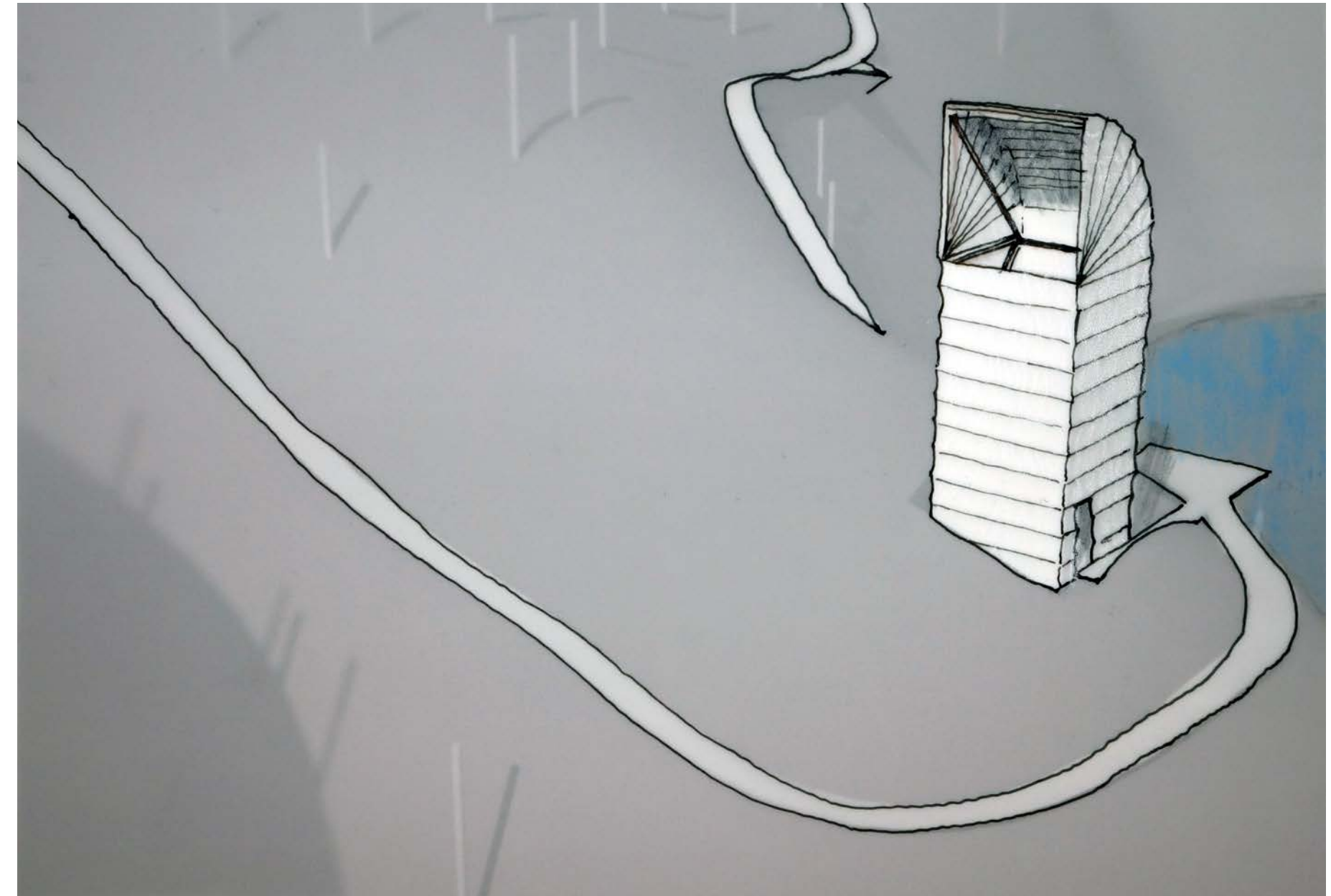

Figure 34. View of Wind Space.

the ascent. The house also functions in a similar capacity where one rests and is encouraged to reflect on the daily experiences.

Material Phenomenology

Each of the four meditation spaces has a specific material palette intended to heighten one's experience of the element in question, while in the space. Because each of the four spaces represents a distinct element, they inherently each have a very distinct character. In order to establish a relationship between the spaces there is an intentional degree of material overlap between adjacent spaces (Fig. 35). This material language also reflects the journey along the path with the materials becoming heavier as one descends.

The other piece of the project that unites each of the spaces is the path. While the path draws from the same material palette as the spaces, its use of materials is reflective of the nature of the landscape at any given point (Fig. 36). Along the path the topography varies greatly, there are flat sections, steep grades and a near free fall. These differences along the path are also affected by the orientation of the path to the topography, where flatter areas move along the grade and steeper sections cut across it.

At the less strenuous segments the path is left in its natural state. This substrate of soil, exposed bedrock, leaves and pine needles is the native state of the forest floor and thus the lowest impact solution. Since the path will be accessed by a limited number of people and they will all be on foot, this trail surface is most appropriate. The native ground condition also allows the visitors to experience an ambulatory encounter hard to find in the urban environment. The softness of the soil underfoot, the rustle of the leaves, the smell of the pine needles, the contrast of the color of the leaves on the ground to those still on the tree.

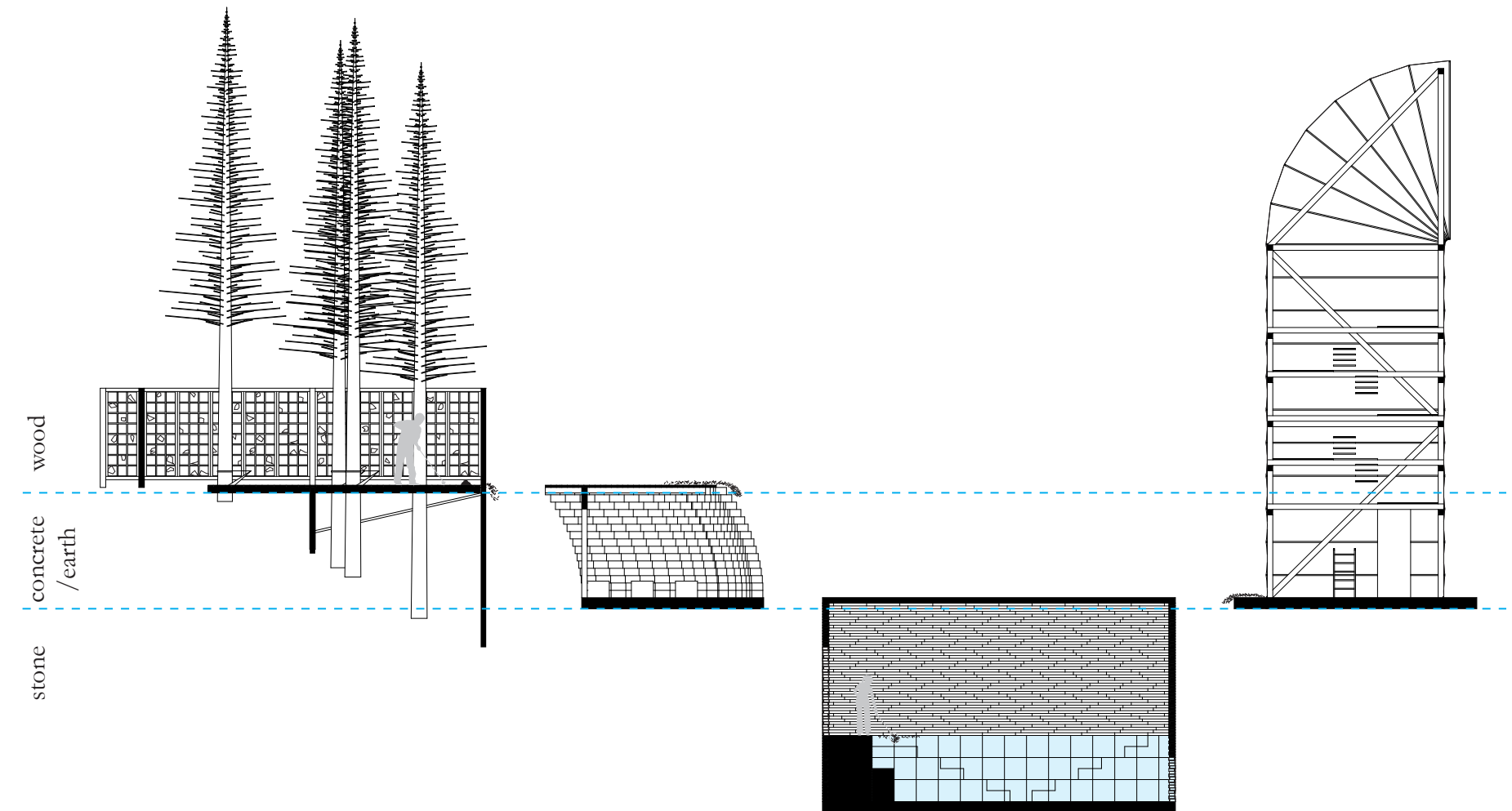

Figure 35. Section of meditation spaces showing material relationships and seasonal up-keep.



a : native material trail surface



b : carved stone steps



c : board-formed concrete terraces

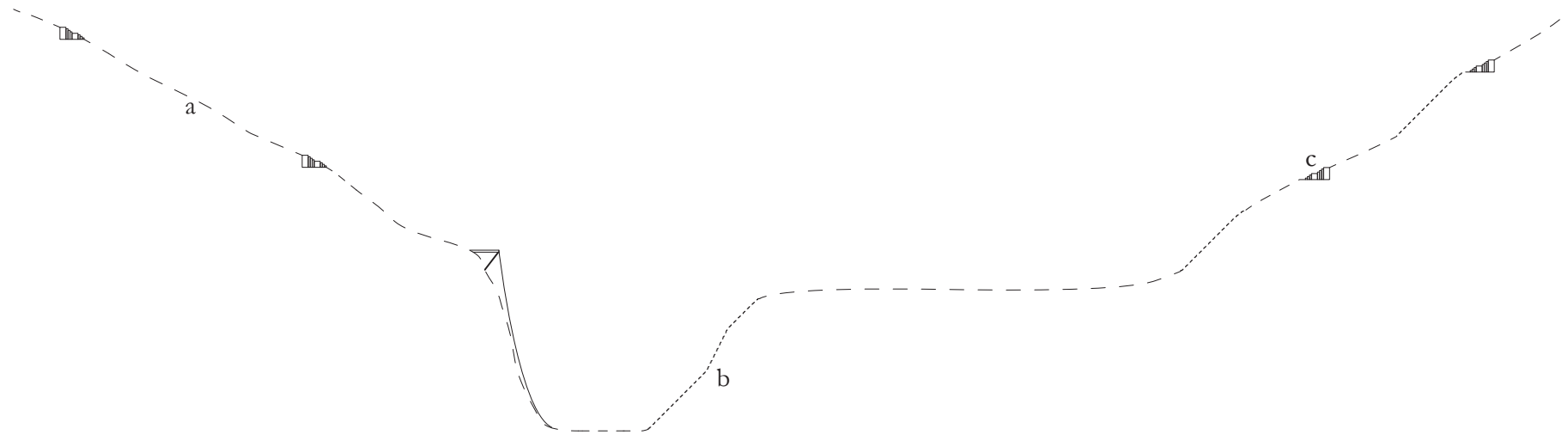

Figure 36. Material specifications of the path.

At steeper points along the trail steps are cut into the granite bedrock. These areas occur when the slope along the path is greater than 30 degrees. The cutting into the ground reveals the granite which is the foundation of the area. The stone is hard yet not stern, the texture and colors of the granite give it an essence at home in this place.

The strenuous nature of the path necessitates points where visitors can rest and reflect on the journey. These terraces are made of board-formed concrete and are distributed about every 100 feet along the inclines. The pattern and texture of the concrete echoes the graining of the wood that was used in its forming. Like the stone, it is unforgiving but not out of place on the path. In the sun, the terraces absorb the heat providing a warm place to rest on chilly days, they also hold the cool of the shade as summers heat encroaches.

The last element of the path is the rope, which leads down to the Water Space. The static rope is designed for repelling down from the platform to the river banks. The rope itself is not the vessel for the experience but it does allow one to take in the surroundings from a very unique perspective, hearing the river below, touching the rock face as one descends, feeling the temperature fall as you approach the bottom.

As one approaches the Tree Space (Fig. 37), one is first confronted with the shoji screen, projecting beyond the main form of the space, drawing one into the space. The Tree Space's material palette is derived from wood construction, the prevalent means of building in the north-western United States. Elements of Japanese design are also a common element in north-west architecture due to its strong ties with Japan. The red cedar structure and shoji screens reflect elements of the local architectural language. The screens control the views, while their translucency allows for the shadows of the surrounding forest to dance

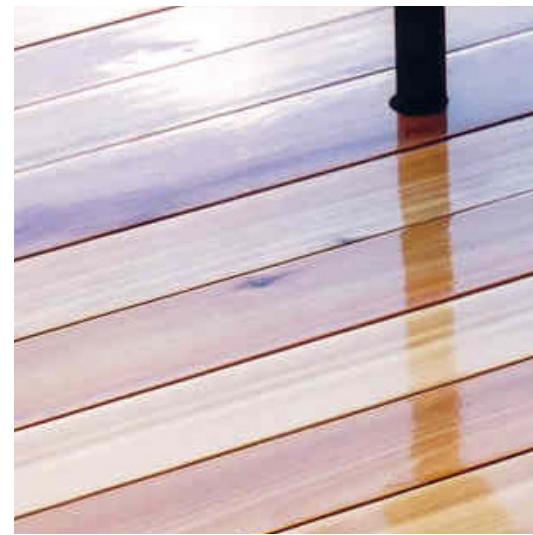
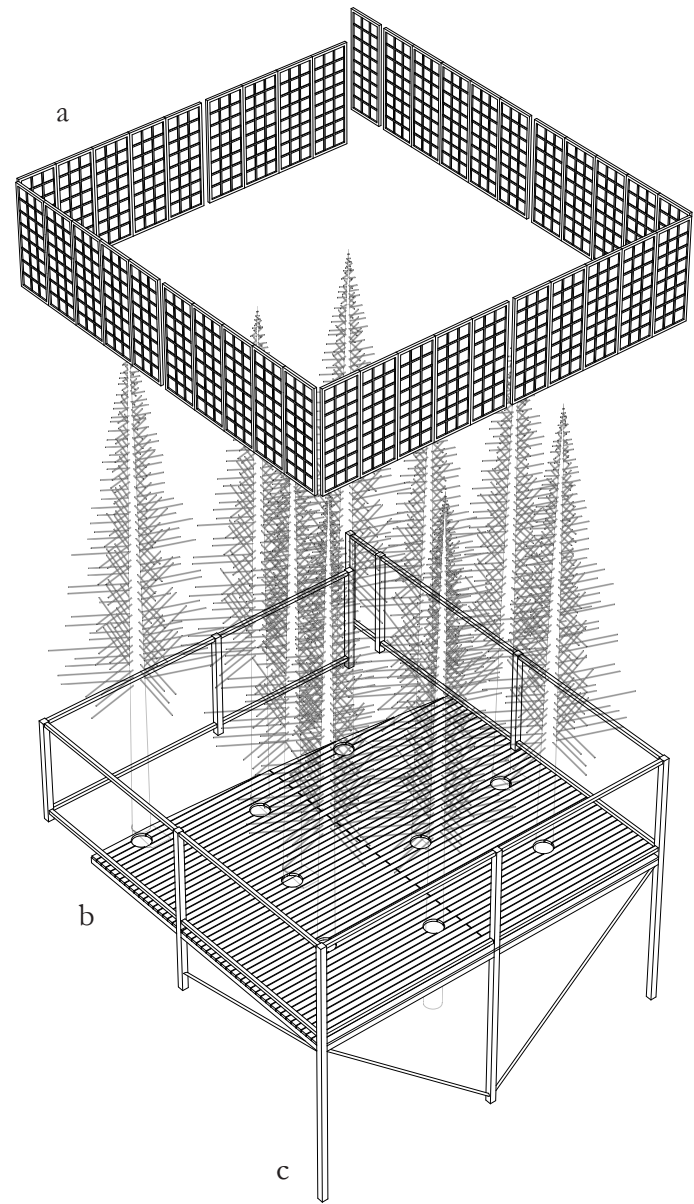

a : 2"x 6" clear red cedar decking with gloss spar varnish finish



b : 3'x 8' - .2 mm laminated shoji paper in 2"x 2" red cedar frames



c : 6"x 6" - rough sawn red cedar framing

Figure 37. Exploded axon of Tree Space with material specifications.

around, hinting at the nature all around. As the paper is confronted with the breeze, it holds firm but releases a crisp tone. The warm glow of the filtered light echoes the warmth present in the coloring of the exposed red cedar elements. The cedar framing is left rough sawn, expressing the rough texture of the bark of the Western Red Cedar trees in the space. The fragrance of the cut cedar signals of the element at play within the space. As one enters the space, a transition occurs from the hard granite floor where the earth was cut, to the red cedar decking which, while sturdy, provides a noticeable give underfoot, telling one that they are no longer on solid ground but experiencing the trees across a static datum, as the ground below follows its natural descent. The glossy finish of the decking emphasizes that, while it is a natural material, it is being used in a way contrary to the natural surface of the ground below.

The noticeable descent down into the ground plane of the Sun Space begins to express the building precedent at play. The Sun Space (Fig. 38) draws its material language from that of the American south-west, an area where the sun is reliably ever-present. The rammed earth wall acts as the formal threshold of the space while the remaining vertical structure is comprised of soil composite CMU blocks. These elements have a distinct mass that shelters one from the views and sunlight. But as the earthen elements are exposed to the sun, they begin to absorb and store its heat, a radiating warmth that calms all but the beads of sweat forming on the skin. As the space warms, the smell of the earthen walls infiltrates one's senses. The rough texture of the walls quiet sounds as they absorb the resonance of the inhabitants. This is in contrast to the high reflectance and smoothness of the concrete floor, which reflects not only sound, but also the sunlight. The polished con-

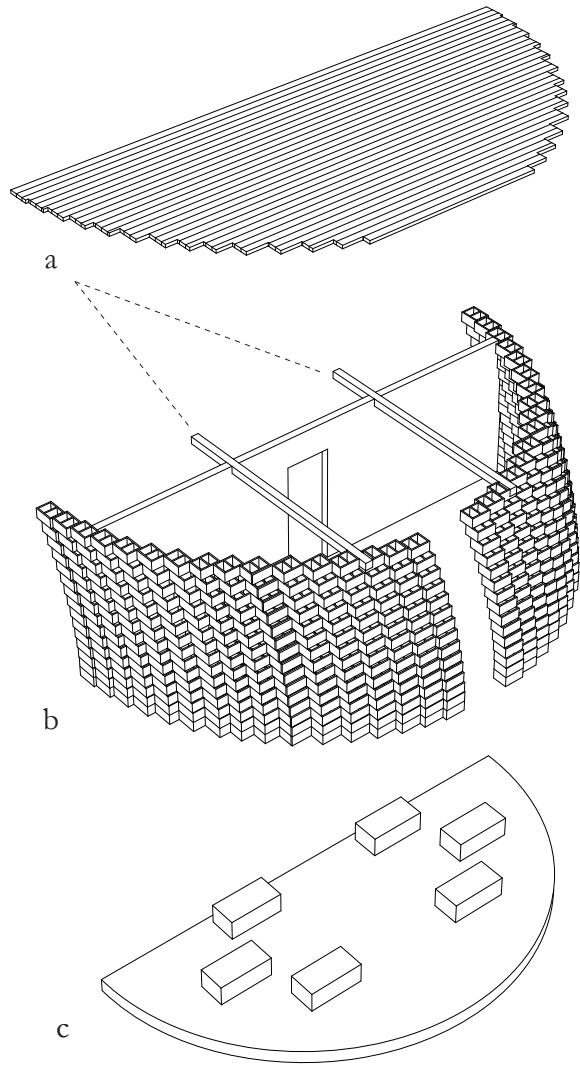

a : 2"x 6" clear stained red cedar decking and 6"x 6" rough sawn red cedar beams



b : 6" rammed earth wall and 8"x 8"x 16" soil composite cmu blocks



c : 12" site-cast polished concrete slab

Figure 38. Exploded axon of Sun Space with material specifications.

crete floor is the canvas by which the inhabitants experience the light. It amplifies the light, reflecting it into the space. This reflection assaults the eye, just as staring at the sun itself, but refuge can be sought in the dark corners.

The Water Space (Fig. 39) uses deep pit quarries as a precedent to develop its material composition. The tall granite walls of the Water Space reflect the sides of the quarry with a pool of water filling its basin. The ledgestone pattern of the walls shows the unmutable power of the natural stone. The texture of the granite pavers haptically echo this without offending the foot with hazards. The water fills the space with cool dense air, the cool reflected in every stone surface. As the water moves in the space it slaps against the stone revealing the force of the river, the drip, the splash, echo through the space. As one descends into the pool, the water surrounds every inch of skin, in the final act of submission, the water fills one's mouth with a refreshing sip. Looking up from the pool, the reflections of the light, as they dart through the water, move like hollow clouds across the ceiling.

The Wind Space (Fig. 40) derives its material expression from the maritime culture of sailboats. The translucent sailcloth skin of the Wind Space functions similarly to the shoji screens of the tree space, filtering light and controlling views while still hinting at the goings on outside through light and shadows. Also, like the shoji, the sailcloth is alive, it breathes with the wind, bellowing as the breeze animates its porcelain skin. The sound of the wind is heard as it is cut by the edge of the sailcloth frame and the wind slaps the cloth in return, for its division. The cedar frames support the platforms, where one becomes a part of the wind. The canvas-covered plywood is stiff but the texture of the canvas gives it a lightness, a texture which longs for contact and provides a spot for repose. All that is carried on the

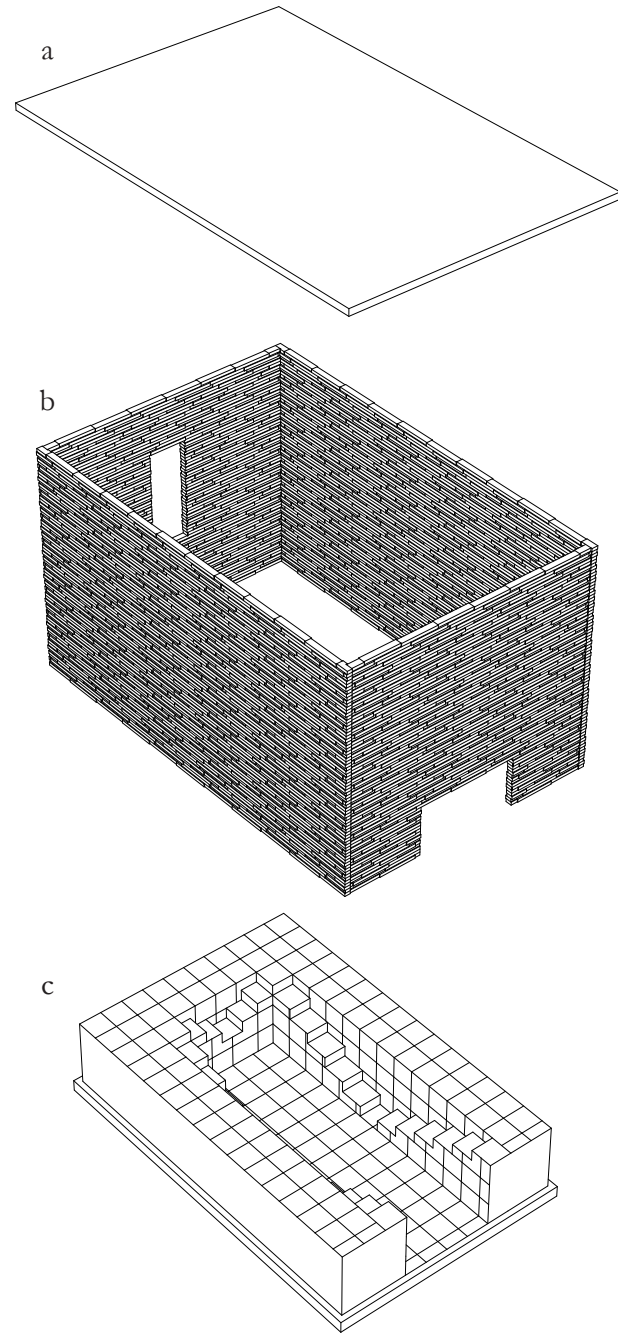

a : 6'' pre-cast concrete slab roof



b : 6''x 3''x 36'' granite block ledgestone walls

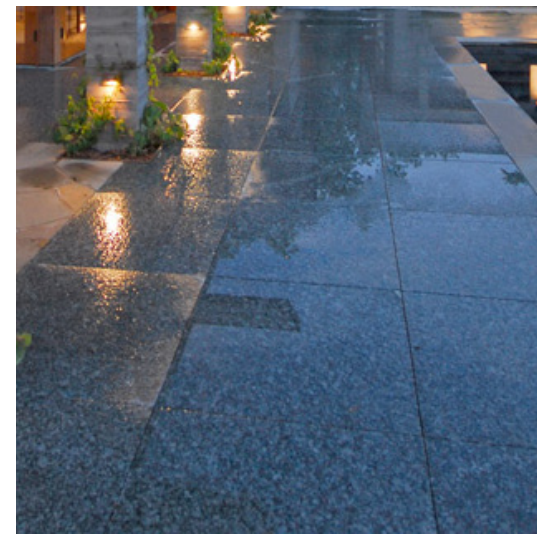

c : 12''x 12''x 2'' - flamed granite pavers over site-cast concrete foundation

Figure 39. Exploded axon of Water Space with material specifications.

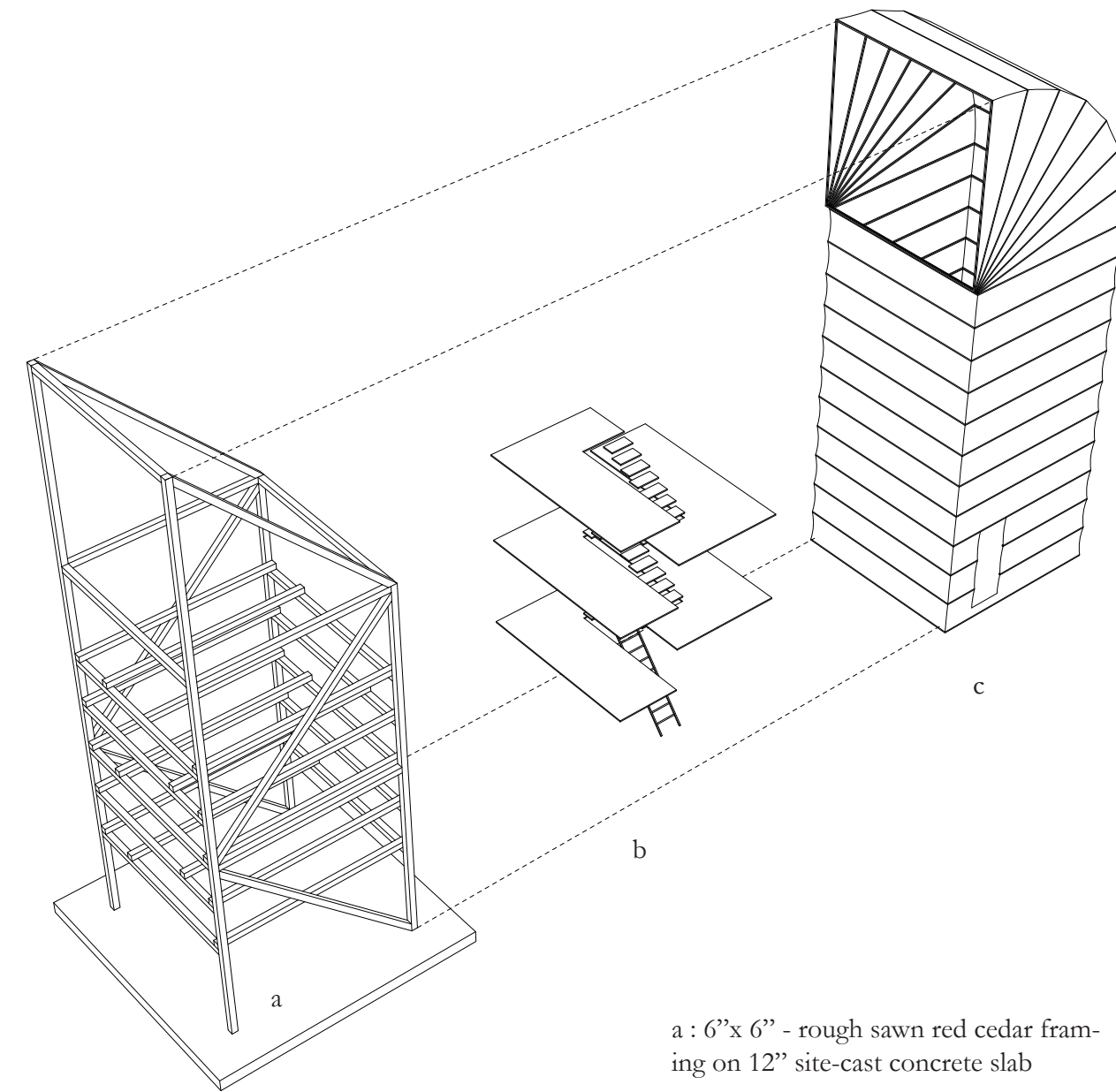

a : 6''x 6'' - rough sawn red cedar framing on 12'' site-cast concrete slab



b : 3/4'' canvas covered marine Baltic birch plywood



c : coated white polyester (PET) sailcloth over 1''x 1'' hs aluminum frames

Figure 40. Exploded axon of Wind Space with material specifications.

wind is funneled through the Wind Space. The sweet smell of sage, the cool water of the river, through the wind, one is offered all that surrounds, but in return the wind flows along the skin, taking body heat, exposed skin sacrificing its warmth, a summertime delight.

CONCLUSION

Man exists as a part of nature, even if unbeknownst to himself. But the actions of the unaware man can be catastrophic. Since the beginning of the environmental movement, it has been evident that man is in fact his own worst enemy. As the knowledge of current environmental situations grows, so does the responsibility to shift from a destructive force, to one driven to remediate indiscretions of the past, if only in the interest of mankind's self preservation. When one realizes that humans are governed by the laws of nature and can not exist "above" them, then the benefit of a healthy natural environment becomes clear.

The goal of this project is to create a journey where man can find his place and reconnect with nature. The most important part of being able to create such a place was to find out how one discovers nature. This experience of nature would then inform the designs by highlighting the elements at play. At the most basic level, the way man experiences any environment in which he finds himself, is directly through his senses. The journey through nature, highlighted with architectural interventions, teasing out the sensory aspects of elements of nature, was explored as a mediator between man and nature.

What was not apparent at the beginning of the design process was how important the areas in between the spaces would be, to the point that landscape was discussed as much as building. In the end the spaces and the path, along which they were distributed, together became the project. The journey not only allowed one to experience the site and see different points of perspective on the strong dichotomy of the man made elements like the dam and the surrounding natural environment of the site, but also provided the active, strenuous contrast to the still, peaceful moments of the meditation spaces. Without one the

other would be left lifeless. This revelation echoed the origin of the thesis in that the spaces needed to be seen as a part of the larger journey not just the reason for the journey.

The difference in scale between the journey and the spaces was one of the most powerful, as well as challenging aspects of this project.. Many of the jury comments touched on this thread and it is probably the main area for further investigation. The development of the project tried to find a way to balance the differing scales, but the extremes of the scales were left as sketches. Development of the larger scale of the overall journey could begin to speak more about the projects place extending into the park and establishing the project as more of a discovery out in the wilderness, as opposed to a more controlled environment. The emphasis on the small scale spurred a more in-depth exploration into the materiality of the spaces and the phenomenological aspects of the experience.

There was also a discussion of the picturesque garden during the final critique. The scale of the journey was seen as a garden experience and included many elements of the picturesque garden with a bridge, follies (meditation spaces) and a relic (the dam). The picturesque garden, which emphasized a more natural aesthetic, originated as a response to the highly geometric and manicured gardens of the renaissance. In his book *The Sacred In-Between*, Barrie (2010) describes the picturesque garden perfectly in the context of this project:

“Through a choreography of space and sequence, light and shadow - in consort with smells, sounds, touch, and in some cases, taste - we are engaged, brought to the present, and thus prepared for connections outside ourselves...The studied picturesque of eighteenth-century English narrative gardens,...aimed to heighten experience through sensual and associative means.”

BIBLIOGRAPHY

Barrie, Thomas. 2010. *The Sacred In-Between*. Routledge, London, England. 272 pp.

Borgmann, Albert. 1984. *Technology and the Character of Contemporary Life*. University of Chicago Press, Chicago, Illinois. 302 pp.

Carson, Rachel. 1965. *The Sense of Wonder*. Harper & Row, New York, New York. 95 pp.

Coates, Gary. 1981. *Resettling America*. Brick House Publishing Co., Andover, Massachusetts. 556 pp.

Crowe, Norman. 1995. *Nature and the Idea of a Man-Made World*. MIT Press, Cambridge, Massachusetts. 270 pp.

Emerson, Ralph Waldo. 1836. *Nature*. J. Munroe and Co., Boston, Massachusetts. 95 pp.

Harper, Douglas. 2012. *Nature*. <http://www.etymonline.com/index.php?term=nature>

Heidegger, Martin. 1971. *Poetry, Language, Thought*. Harper & Row, New York, New York. 229 pp.

Heschong, Lisa. 1979. *Thermal Delight in Architecture*. MIT Press, Cambridge, Massachusetts. 78 pp.

Hildebrand, Grant. 1999. *Origins of Architectural Pleasure*. University of California Press, Berkeley, California. 174 pp.

Holl, S., J. Pallasmaa, and A. Perez-Gomez. 1994. *Questions of perception: phenomenology of architecture*. A + U, Tokyo, Japan.

Kaplan, Stephen. 1995. *The Restorative Benefits of Nature: Toward An Integrative Framework*. *Journal of Environmental Psychology* 15, 3: 169-182.

Mugerauer, Robert. 1995. *Interpreting Environments*. University of Texas Press, Austin, Texas. 186 pp.

Norberg-Schulz, Christian. 1980. *Genius Loci*. Rizzoli, New York, New York. 213 pp.

Norberg-Schulz, Christian. 1996. *Nightlands: Nordic Building*. MIT Press, Cambridge, Massachusetts. 230 pp.

Oxford University Press. 2012. *Nature*. <http://oxforddictionaries.com/definition/nature?q=nature>

———. 2012. *Phenomenology*. <http://oxforddictionaries.com/definition/phenomenology?q=phenomenology>

———. 2012. *Shelter*. <http://oxforddictionaries.com/definition/shelter?q=shelter>

Pallasmaa, Juhani. 2005. *The Eyes of the Skin*. Wiley-Academy, West Sussex, England. 80 pp.

Pitzer, Paul. 2001. *Building the Skagit*. Seattle City Light, Seattle, Washington. 89 pp.

Ramos, Kelsey. 2011. *America's hidden gems: The 20 least-crowded national parks in 2009*. <http://www.latimes.com/travel/la-tr-national-parks-least-visited-pg,0,1882660.photogallery>

Tanizaki, Jun'ichiro. 1977. *In Praise of Shadows*. Leete's Island Books, Sedgwick, Maine. 48 pp.

Thoreau, Henry David. 1854. *Walden*. Ticknor and Fields, Boston, Massachusetts. 357 pp.

Ulrich, R.S., R.F. Simons, B.D. Losito, E. Fiorito, M.A. Miles, and M. Zelson. 1991. Stress Recovery During Exposure to Natural and Urban Environments. *Journal of Environmental Psychology* 11, 3: 201-230.

United Nations. 2005. *World Urbanization Prospects: the 2005 Revision*. <http://www.un.org/esa/population/publications/WUP2005/2005wup.htm>

US Environmental Protection Agency. 2010. *Ecoregions of Washington*. http://www.epa.gov/wed/pages/ecoregions/wa_eco.htm

US Forest Service. 2012. *Skagit WSR - Outstanding Fisheries*. http://www.fs.usda.gov/detail/mbs/landmanagement/resourcemanagement/?cid=fsbdev7_001691

Wilson, Edward. 1984. *Biophilia*. Harvard University Press, Cambridge, Massachusetts. 157 pp.

World Health Organization. 2012. *Urban Population Growth*. http://www.who.int/gho/urban_health/situation_trends/urban_population_growth_text/en/index.html

Image References

All images produced by the author unless noted below

Figure 8. Google. <http://maps.google.com/>

Figure 9. Google. <http://maps.google.com/>

Figure 10. US National Park Service. <http://www.nps.gov/noca/planyourvisit/upload/NOCAMap3.pdf>

Figure 11. US National Park Service. http://www.nps.gov/noca/planyourvisit/upload/rosslake_6-08.pdf

Figure 12. USEPA. ftp://ftp.epa.gov/wed/ecoregions/wa/wa_eco.pdf

Figure 13. Seattle City Light.

Figure 14. Seattle City Light.

Figure 36a. Djan Stewart. <http://djanstewart.blogspot.com/2011/09/wonderful-mt-dickerman.html>

Figure 36b. Stephan Romano. http://www.crackedframe.com/photos/gallery/Peru/4-Inca-Trail/inca_017_DSC_5521

Figure 36c. Concrete Network. <http://www.concretenetwork.com/board-formed-concrete>

Figure 37a. WoodsGood. <http://woodsgood.ca/images/CedarDeckSetTable.jpg>

Figure 37b. Eco-komina. http://eco-kominka.blogspot.com/2011_02_01_archive.html

Figure 37c. Timber Springs Farm. <http://timberspringsfarm.blogspot.com/>

Figure 38a. Peter Fritz Photography. <http://www.archdaily.com/204758/muskoka-boat-house-christopher-simmonds-architect/13-261/>

Figure 38b. David Easton. <http://terrashouse.rammedearthworks.com/2009/11/earth-block-bathroom-roof-membrane.html>

Figure 38c. Danamac. <http://danamacconcrete.files.wordpress.com/2010/05/hotson-res-0022.jpg>

Figure 39a. Wren's Nature Notebook. <http://wrensnaturenotebook.blogspot.com/2010/08/stroll-along-river-thames.html>

Figure 39b. Earth's Finest Stone. http://www.earthsfineststone.com/uploads/Products/product_96/Firestorm_Granite_Ledgestone_Thin_Veneer_10.JPG

Figure 39c. Keenan & Sveiven. <http://www.kslandarch.com/fire.html>

Figure 40b. Cam Weaver. http://cweaver49.files.wordpress.com/2011/03/img_0002.jpg

Figure 40c. EventQuip. <http://www.eventquip.com/wordpress/wp-content/uploads/sailcloth-tents-philadelphia-party-rentals-eventquip-weddings.jpg>