

Urban Instigators: Reclaiming the Duwamish Waterways

Marcus Wendl Crider

A thesis

submitted in partial fulfillment of the

requirements for the degree of

Masters of Architecture

University of Washington

2014

Committee:

Committee Chair : Nicole Huber

Committee Member : Rob Corser

Program Authorized to Offer Degree:

Architecture

University of Washington

Abstract

[Urban Instigators: Reclaiming the Duwamish Waterways]

[Marcus Wendl Crider]

Chair of the Supervisory Committee:

[Associate Professor Nicole Huber]

[Architecture]

The Duwamish waterway is a river shaped and scared by industry. It has been a vital working waterway of Seattle for over 100 years. The Duwamish Waterway is the larger of two MIC's (manufacturing and industrial center) in Seattle and is a crucial job base for the region by employing more than 100,000 people. The Duwamish Waterway is an interracial part in Seattle's economy by supporting commercial navigation, employment, and commerce. As a result the shores of the Duwamish have been heavily industrialized and its waters contaminated from over a century of industrial use. Communities along the Duwamish, such as Georgetown and South Park have been cut off from its shores leaving discarded lands and communities disconnected from recreational use.

My thesis proposes a community based re-industrialization of experience economies on discarded sites in effort to reintroduce the Duwamish Waterway to the surrounding communities. To accomplish this I propose the insertion of a new manufacturing industry focused on the production of experience economies using the tools of industry, such as shipping containers and barges to deploy program elements down the Duwamish Waterway to reclaim discarded sites for the surrounding communities.

© Copyright [2014]  
[Marcus Wendl Crider]

# Urban Instigators: Reclaiming the Duwamish Waterways



# Urban Instigators: Reclaiming the Duwamish Waterways

University of Washington College of Built Environments  
Thesis Document : Marcus Wendl Crider  
Thesis Committee Chair : Nicole Huber  
Thesis Committee Member : Rob Corser

Thesis Statement	3
The Duwamish Today	5
What Are The Problems?	7
How It Got There	9
What Do We Do?	11
How It Works	19
The Manufacturing Hub	21
Herring's House Park	24
Gateway Park	27
The Duwamish Waterway Park	30
Conclusion	34
Bibliography	36
Image Bibliography	39

A friend once said to me, "If it's shiny or metal you'll pick it up and take it home".

My Mom even told me as a child I used to find random discarded objects and try to make things out of them. I have always had this tendency to find scraps material and make things. Even when I worked as a cook my favorite thing was making soup, rummaging through the walk-in cooler and finding scraps, throwing them in a pot and making it taste good. Without even realizing it my thesis project has become a byproduct of this ability to find a use where others might see uselessness.

### Urban Instigators: Reclaiming the Duwamish Waterways

The Duwamish waterway is a river shaped and scared by industry. It has been a vital working waterway of Seattle for over 100 years. The Duwamish Waterway is the larger of two MIC's (manufacturing and industrial center) in Seattle and is a crucial job base for the region by employing more than 100,000 people.<sup>1</sup> The Duwamish Waterway is an interracial part in Seattle's economy by supporting commercial navigation, employment, and commerce. As a result the shores of the Duwamish have been heavily industrialized and its waters contaminated from over a century of industrial use. Communities along the Duwamish, such as Georgetown and South Park have been cut off from its shores leaving discarded lands and communities disconnected from recreational use.

My thesis proposes a community based re-industrialization of experience economies on discarded sites in effort to reintroduce the Duwamish Waterway to the surrounding communities. To accomplish this I propose the insertion of a new manufacturing industry focused on the production of experience economies using the tools of industry, such as shipping containers and barges to deploy program elements down the Duwamish Waterway to reclaim discarded sites for the surrounding communities.

<sup>1</sup> The Lower Duwamish Waterway, Lower Duwamish Waterway Group, 2013, Jan. 20, 2014. <<http://www.ldwg.org/>>



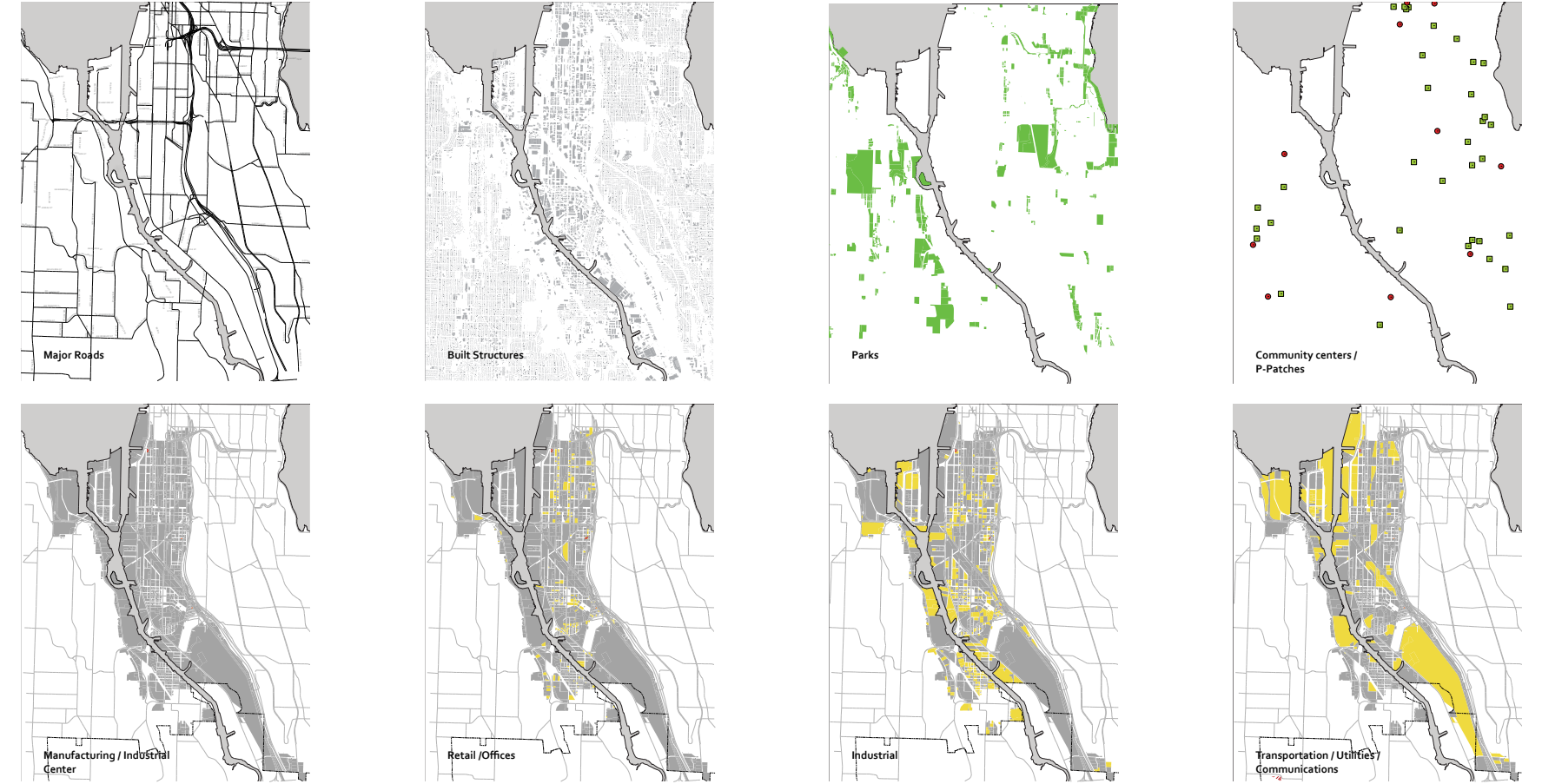
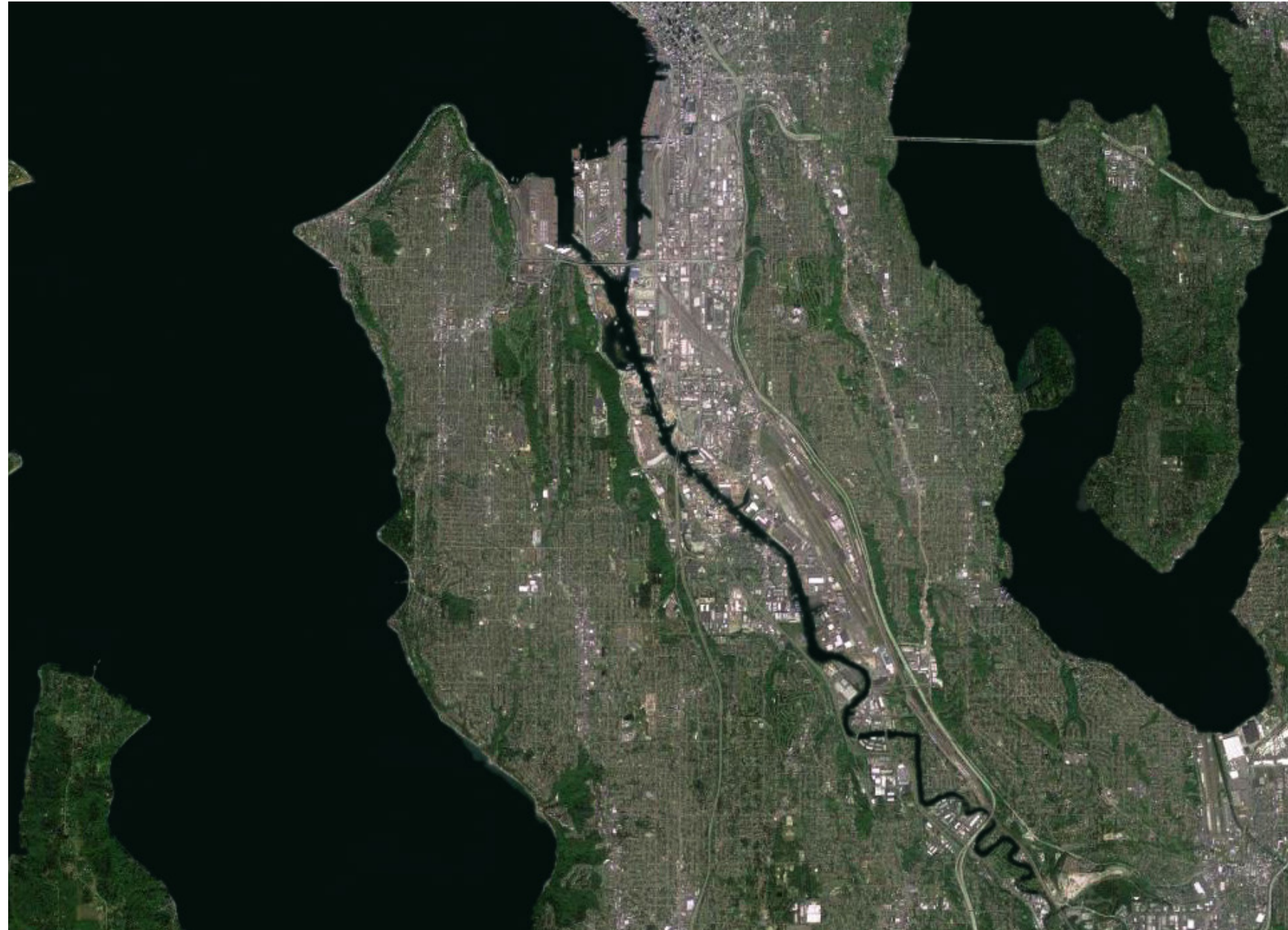

This is the Duwamish Waterway as it is today. From the maps we can see the major roads, built structures, parks in the surrounding area, community centers and P-patches, and the Manufacturing and Industrial Center (MIC). The Duwamish MIC is approximately 5000 acres.<sup>2</sup> To give you a reference for scale, Harbor Island is roughly 1.5 miles long. There are nearly 58,000 employees of the MIC, the majority being manufacturing, wholesale trade utilities, and services. Another 42,000 people are employed by supporting businesses such as restaurants, cafes, gas stations and other non-industrial businesses.<sup>3</sup> As seen by the last three maps the land use is broken down by retail and office use, industrial use, and transportation / utilities / communications taking the most use of the MIC.<sup>4</sup>

<sup>2</sup> Duwamish Industrial Lands Study, Department of Planning and Development, Nov. 2013, Feb. 2014, <[http://www.seattle.gov/dpd/cs/groups/pan/@pan/documents/web\\_informational/p1903847.pdf](http://www.seattle.gov/dpd/cs/groups/pan/@pan/documents/web_informational/p1903847.pdf)>

<sup>3</sup> The Lower Duwamish Waterway, Lower Duwamish Waterway Group, 2013, Jan. 20, 2014. <<http://www.ldwg.org/>>

<sup>4</sup> Duwamish Industrial Lands Study, Department of Planning and Development, Nov. 2013, Feb. 2014, <[http://www.seattle.gov/dpd/cs/groups/pan/@pan/documents/web\\_informational/p1903847.pdf](http://www.seattle.gov/dpd/cs/groups/pan/@pan/documents/web_informational/p1903847.pdf)>

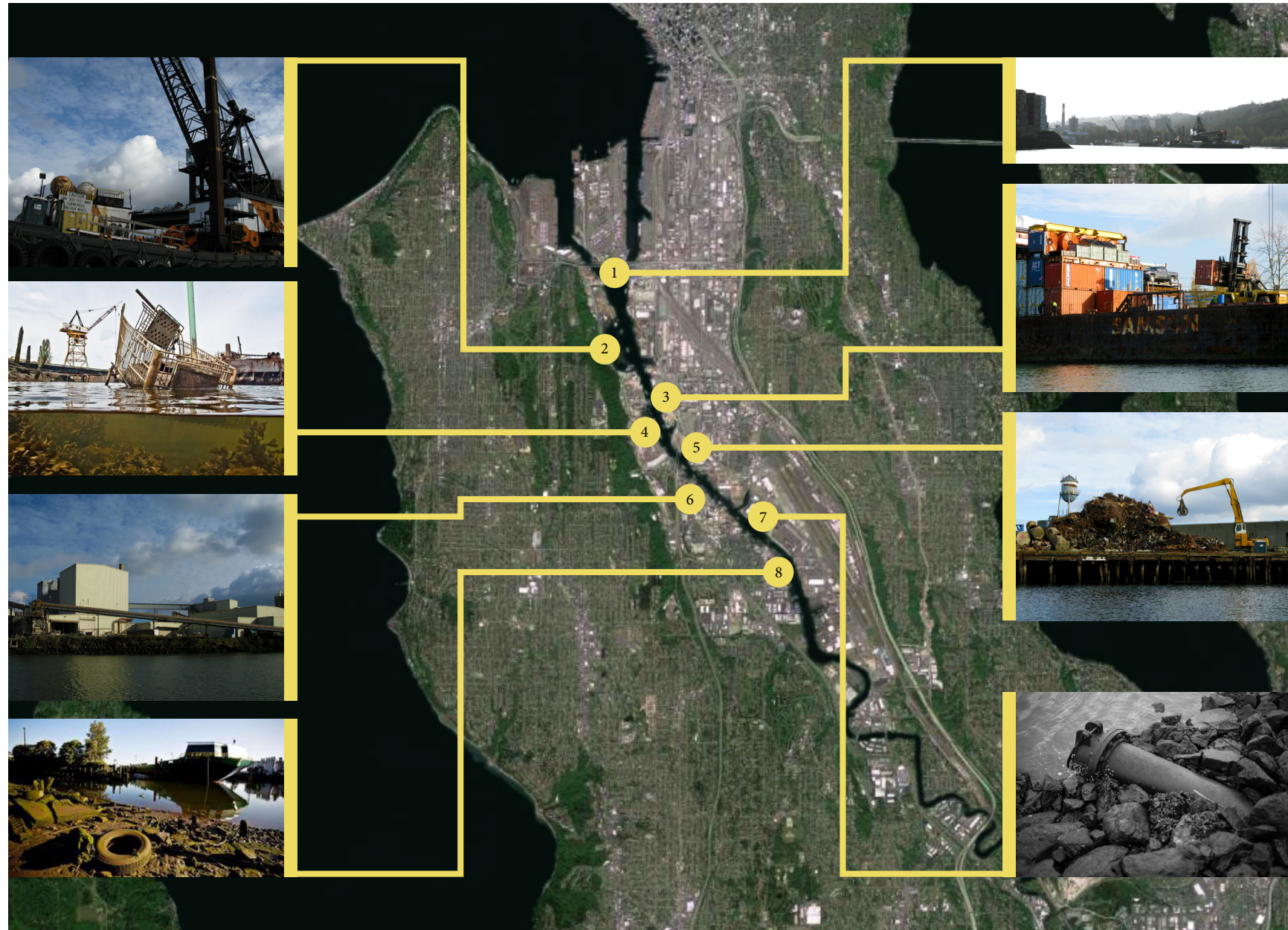

### What are the problems?

In 2001 the Environmental Protection Agency (EPA) listed the five mile stretch of the Duwamish river as a Superfund Site.<sup>5</sup> “Superfund is the name given to the environmental program established to address abandoned hazardous waste sites. It is also the name of the fund established by the Comprehensive Environmental Response, Compensation and Liability Act of 1980. It allows the EPA to clean up such sites and to compel responsible parties to preform cleanups or reimburse the government for EPA-lead cleanups”<sup>6</sup>

The Duwamish River is one of the most industrialized waterways in Washington State. “The EPA has identified 42 chemicals that are above environmental and health standards. The most common chemicals include PCB’s (polychlorinated biphenyls); mercury, lead other metals; and arsenic. These industrial carcinogens are by products of the heavy metals in ship paint, arsenic in cement material, oil in storm water runoff from city streets, and raw industrial and domestic waste from overflowing sewage pipes.”<sup>7</sup> According to the Duwamish River Cleanup Coalition, “today, since most industries are watched and regulated the biggest problem is from Wastewater from our homes and businesses that flow into the river through storm drains and overburdened Combined Sewer Overflows (CSOs)”<sup>8</sup>

The buildup of major industries along the Duwamish River has affected communities such as Georgetown and South Park from being able to experience or even use the waterway. In 2002 Seattle City Council unanimously approved Pro Parks Levy Opportunity Fund.<sup>9</sup> This allowed the city to acquire property along the Duwamish Waterway to expand neighborhood parks and enhance salmon habitats. The cities goal is to reconnect these communities to Duwamish, to educate them about the Rivers history in hopes that communities such as Georgetown and South Park will reclaim ownership of these discarded sites.<sup>10</sup>

<sup>5</sup> Lower Duwamish Waterway Superfund Site, U.S. Environmental Protection Agency, Feb. 15 2014, Feb. 24 2014, <<http://yosemite.epa.gov/r10/cleanup.nsf/sites/lduwamish>>  
<sup>6</sup> What is Superfund?, U.S. Environmental Protection Agency, Dec. 24 2013, Feb. 24 2014, <<http://www.epa.gov/superfund/about.htm>>  
<sup>7</sup> What's in the River?, Duwamish River Cleanup Coalition, 2014, Feb. 24 2014, <<http://duwamishcleanup.org/home/whats-in-the-river/>>  
<sup>8</sup> What's in the River?, Duwamish River Cleanup Coalition, 2014, Feb. 24 2014, <<http://duwamishcleanup.org/home/whats-in-the-river/>>  
<sup>9</sup> Pro Parks Levy, Seattle Parks and Recreation, 2014, Feb. 24 2014, <<http://www.seattle.gov/parks/propparks/>>  
<sup>10</sup> Pro Parks Levy, Seattle Parks and Recreation, 2014, Feb. 24 2014, <<http://www.seattle.gov/parks/propparks/>>



### How It Got There

Seattle's Duwamish River was once home to the Native Americans of the Duwamish tribe. They fished the river, hunted game, and gathered crops from the fertile flood plain soil surrounding the Duwamish River, indicated by the dark green on the maps on page 9.<sup>11</sup> Much like the Native Americans the first European American settlers took advantage of the fertile soil of the Duwamish flood plain they planted crops and built farms along its shore using the river to transport crops to Seattle markets. These small farms eventually became the towns of Georgetown and South Park.<sup>12</sup>

As Seattle grew so did the need for industrial lands. "In 1909, at the urging of City Engineer R.H. Thomson Seattle formed the Duwamish Waterway Commission to re-channel the river. A deeper, straighter river would allow ships to navigate to the industries envisioned for the reclaimed lands and would also alleviate the flooding that plagued the area".<sup>13</sup> "In 1913, the straightening of the Duwamish River into the Duwamish Waterway begins. Twenty million cubic yards of mud and sand are moved until the bends of the river are filled and the main channel is deepened".<sup>14</sup>

By 1920, the lazy meanders had been straightened into a 4.5 mile deep channel that would accept ocean-going ships and barges. As a result industry began to develop at a rapid pace along the banks of the waterway. Businesses such as Boeing have taken full advantage of the Duwamish Waterway for over a century and have now started to give back. Cleanup efforts by Boeing have been praised by organizations such as The Duwamish River Cleanup Coalition.

<sup>11</sup> Culture and History, Duwamish Tribe, 2011, Feb. 24 2014, <<http://duwamishtribe.org/culture.html>>  
<sup>12</sup> Culture and History, Duwamish Tribe, 2011, Feb. 24 2014, <<http://duwamishtribe.org/culture.html>>  
<sup>13</sup> Straightening of The Duwamish River, History Link, 2014, Feb. 24 2014, <[http://www.historylink.org/index.cfm?DisplayPage=output.cfm&File\\_Id=2986](http://www.historylink.org/index.cfm?DisplayPage=output.cfm&File_Id=2986)>  
<sup>14</sup> Straightening of The Duwamish River, History Link, 2014, Feb. 24 2014, <[http://www.historylink.org/index.cfm?DisplayPage=output.cfm&File\\_Id=2986](http://www.historylink.org/index.cfm?DisplayPage=output.cfm&File_Id=2986)>

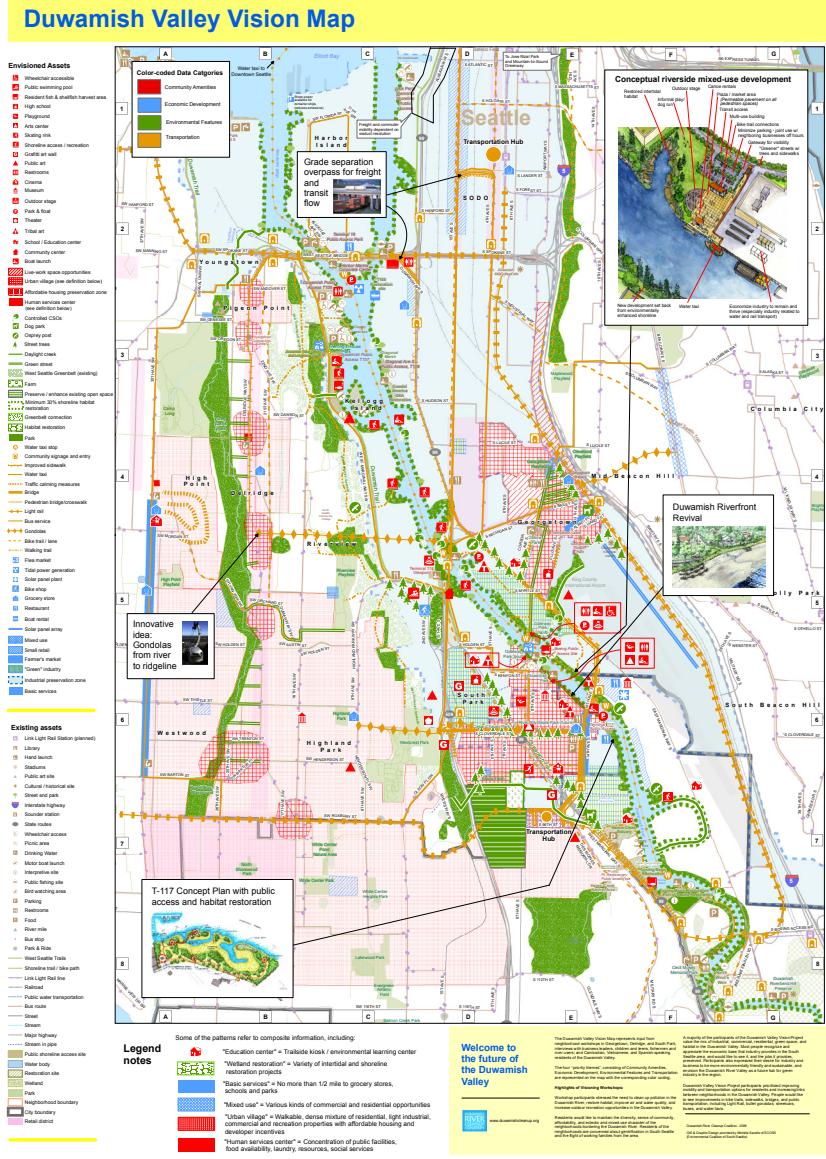

### Envisioned Assets

- Wheelchair accessible
- Public swimming pool
- Resident fish & shellfish harvest area
- High school
- Playground
- Arts center
- Skating rink
- Shoreline access / recreation
- Graffiti art wall
- Tribal art
- Public art
- Restrooms
- Cinema
- Museum
- Outdoor stage
- Park & float
- Theater
- School / Education center
- Community center
- Boat launch
- Live-work space opportunities
- Urban village
- Affordable housing preservation zone
- Human services center (laundry, showers, store)

### Existing Assets

- Hand launch
- Restrooms
- Cultural / historical site
- Public art site
- Library
- Wheelchair access

### Legend notes

Some of the patterns refer to composite information, including:

- "Education center" = Trailside kiosk / environmental learning center
- "Urban village" = Walkable, dense mixture of residential, light industrial, commercial and recreation properties with affordable housing and developer incentives
- "Human services" = Concentration of public facilities, food availability, laundry, resources, social services

### Duwamish Valley Vision map: Community Amenities

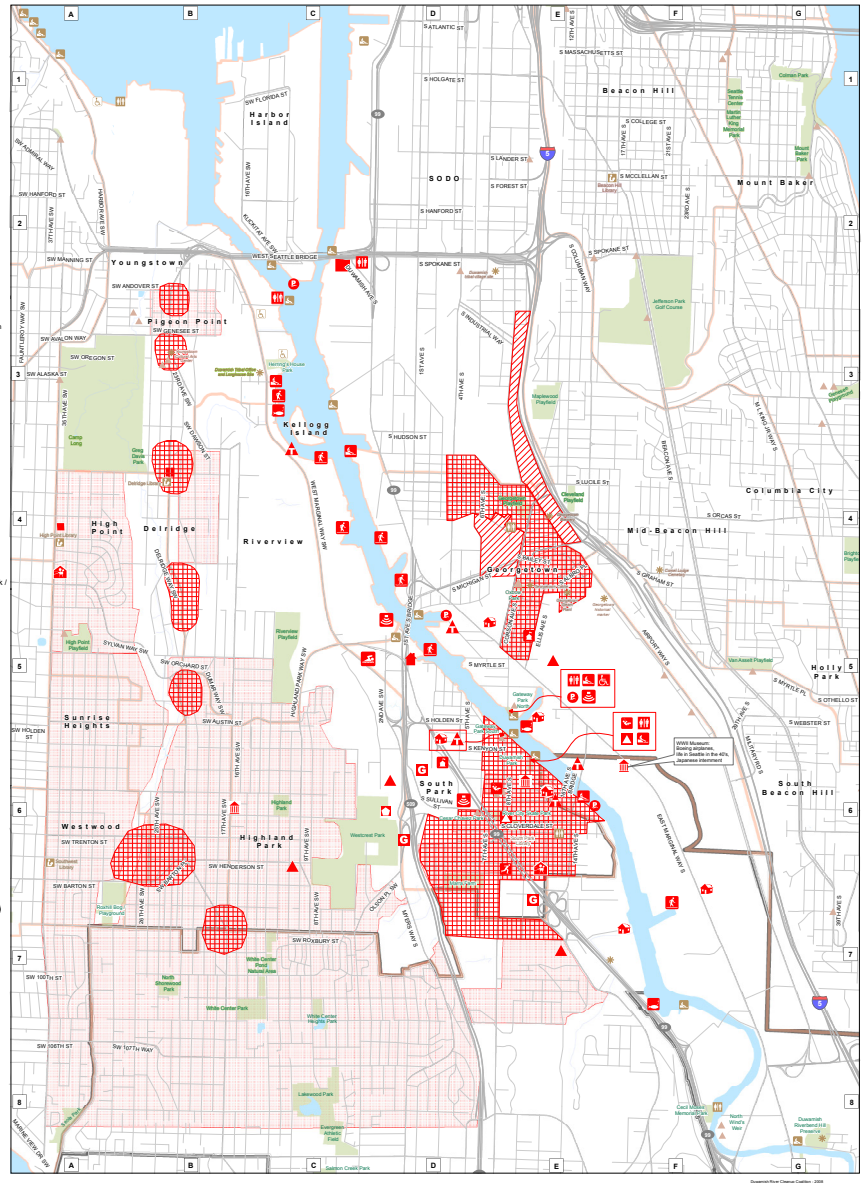



Heterotopia is a concept in human geography elaborated by philosopher Michel Foucault to describe places and spaces that function in non-hegemonic conditions. These are spaces of otherness, which are neither here nor there, that are simultaneously physical and mental

Brothels and colonies are two extreme types of heterotopia, and if we think, after all, that the boat is a floating piece of space, a place without a place, that exists by itself, that is closed in on itself and at the same time is given over to the infinity of the sea and that, from port to port, from tack to tack, from brothel to brothel, it goes as far as the colonies in search of the most precious treasures they conceal in their gardens, you will understand why the boat has not only been for our civilization, from the sixteenth century until the present, the great instrument of economic development but has been simultaneously the greatest reserve of the imagination. The ship is the heterotopia par excellence. In civilizations without boats, dreams dry up, espionage takes the place of adventure, and the police take the place of pirates.”

from Michel Foucault, *Of Other Spaces* (1967), *Heterotopias*

What do we do?

On page 11 is the Duwamish River Clean up Coalition’s Vision plan. They summarize that “The Duwamish Vision is an ongoing, comprehensive, community-based future visioning project, which engaged people who live, work or visit the Duwamish Valley through workshops, mapping and interviews”.<sup>15</sup> Some highlights are water taxis, bike trails, restaurants, boat rental, parks, gardens and so on. Like most vision plans it’s dreaming big. For example they propose a series of gondolas linking west Seattle to the Duwamish River, which seems a little weird.

**Nevertheless they do see that the industry is needed and essential to the surrounding communities and the economy of Seattle.** They are not looking to de-industrialize but almost to re-industrialize with community amenities or experience economies. Focusing on the community amenities such as restaurants, cafes, theater space, and so I began to devise program elements that could either be placed inside shipping containers and or barges which are abundant and easily obtained from the area.

<sup>15</sup> *The Duwamish Vision*, The Duwamish River Cleanup Coalition, 2014, Feb. 24 2014, <<http://duwamishcleanup.org/?s=vision+plan>>

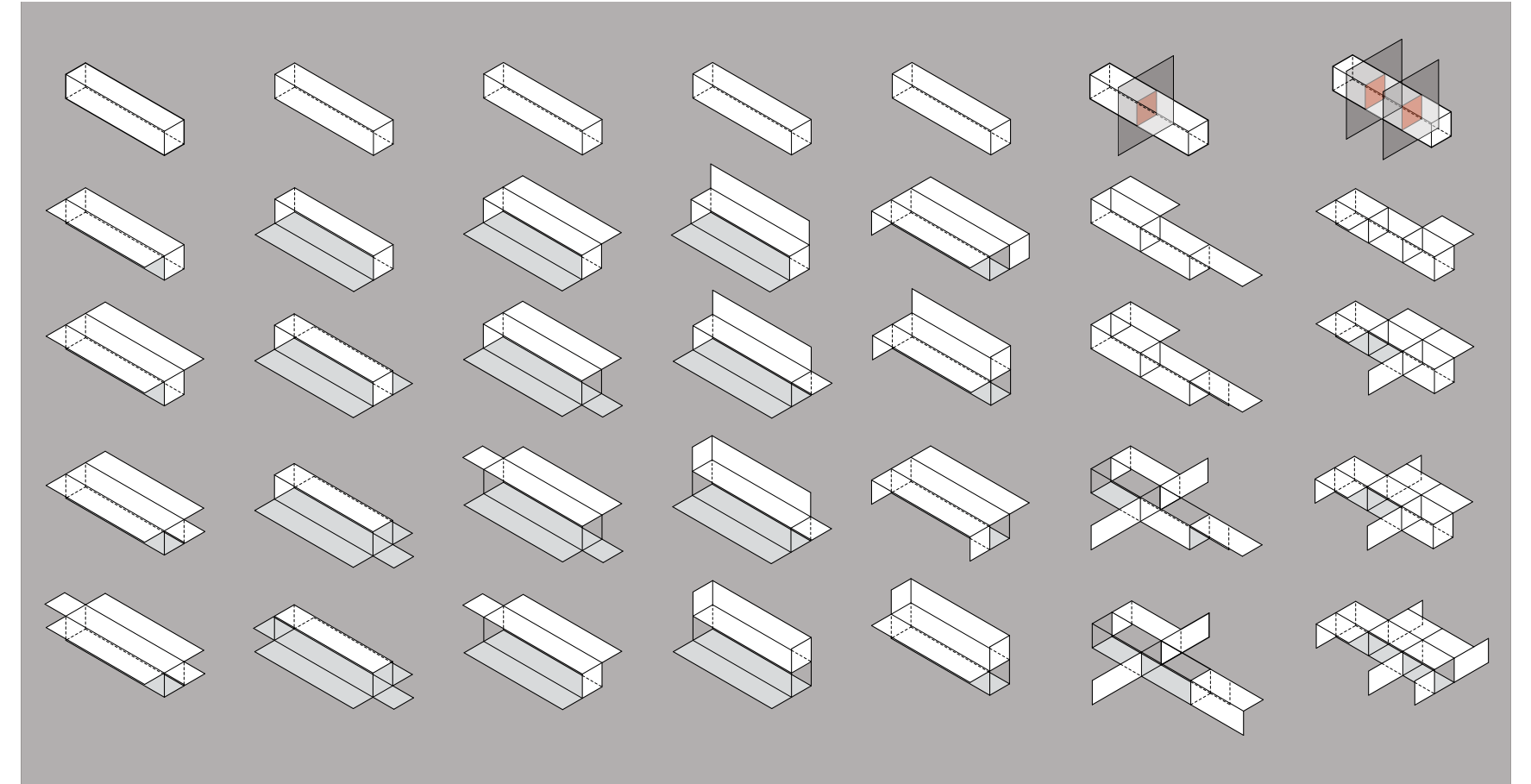
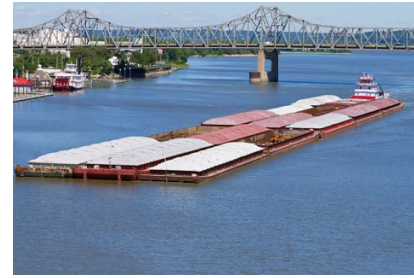
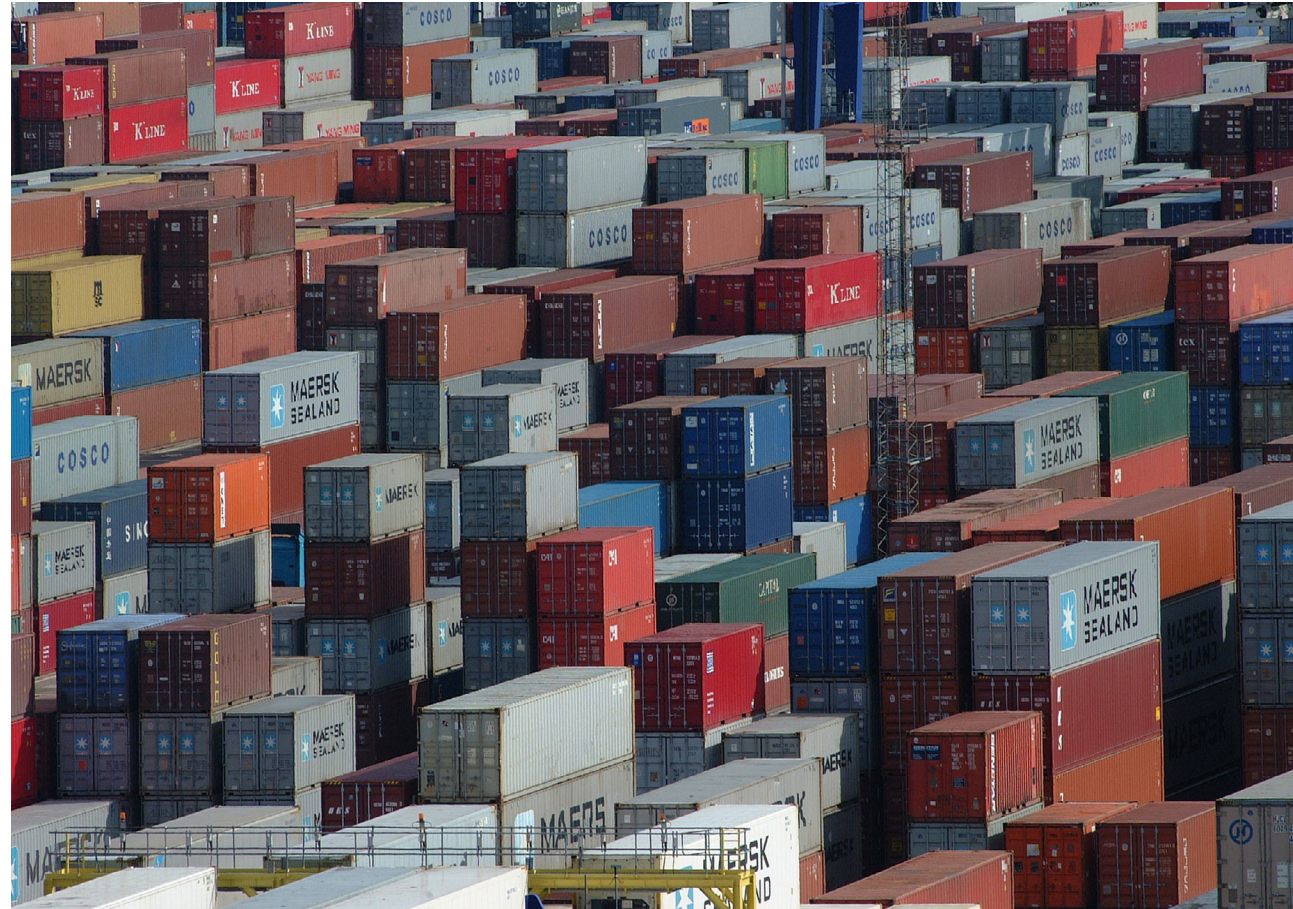

In early 2011 there was a global fleet of nearly 5,000 container ships each carrying roughly 14 million containers a year.<sup>16</sup> That's 70,000,000,000 containers shipped in one year. As a result of their sheer abundance containers are easily found and affordable. Online new containers range from \$2000 - \$5000 and used are even cheaper depending on size and damage.<sup>17</sup> As you can see from the diagrams shipping containers are moment frames with side shear panels. By slicing, shifting, and moving these side panels almost any configuration is possible. Likewise barges are easily accessible and sold online.<sup>18</sup> Barges come in many different types and sizes depending on the job required of them.

<sup>16</sup> Martin Craig, *The Shipping Container*, The Atlantic, Dec. 2 2013, Feb. 24 2014, <<http://www.theatlantic.com/technology/archive/2013/12/the-shipping-container/281888/>>  
<sup>17</sup> Standard container, Job Site Express, 2014, Feb. 24 2014, <<http://www.jobsiteexpress.com/servlet/the-12469514oGP-NEW-Standard-Container/Detail>>  
<sup>18</sup> Barges for sale, Maritime Sales Inc, 2010, Feb. 24 2014, <<http://www.maritimesales.com/barges%20for%20sale.htm>>

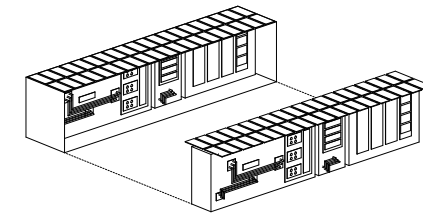
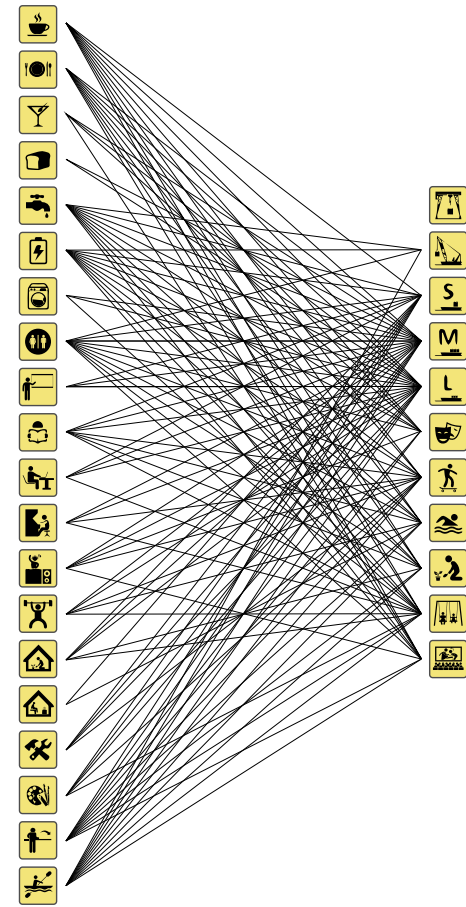
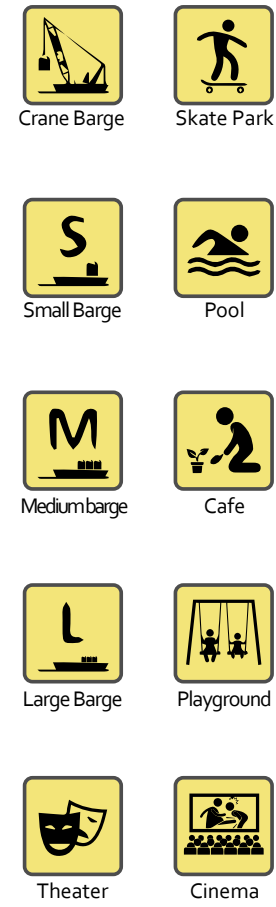

Utilities: Water/Electric

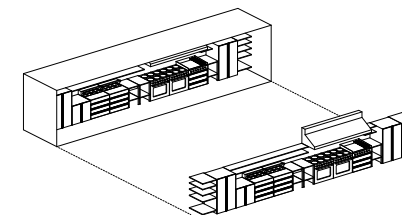

Commercial Kitchen

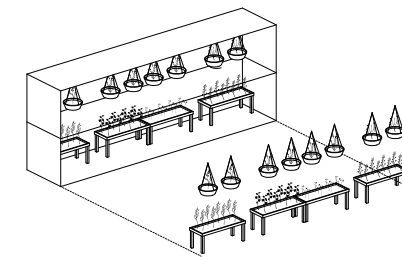

Large Greenhouse

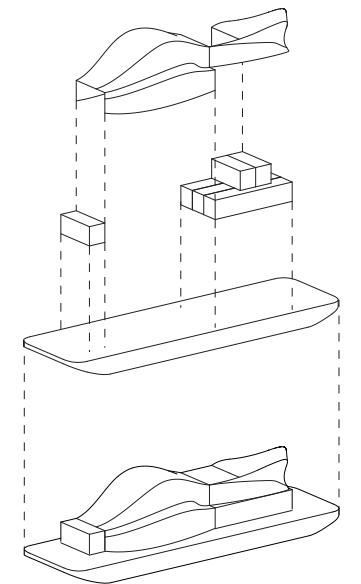

Pneumatic Structure

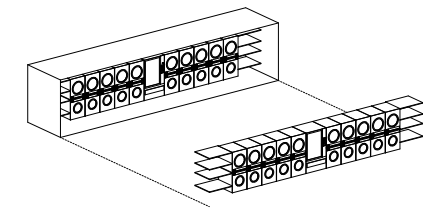

Laundry Facility

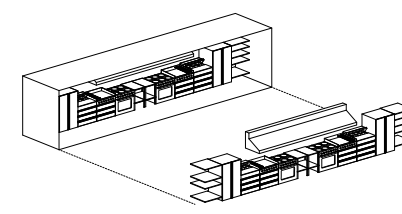

Educational Kitchen

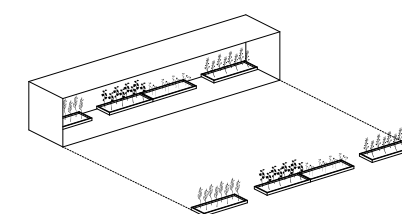

Small Greenhouse

By taking the Duwamish River Cleanup Coalition's amenities vision plan I started to configure types of program that could be placed in containers and also designating types of barges. To create occupy-able space between the containers lightweight structures would be deployed such as pneumatic structures and stretched canvas.

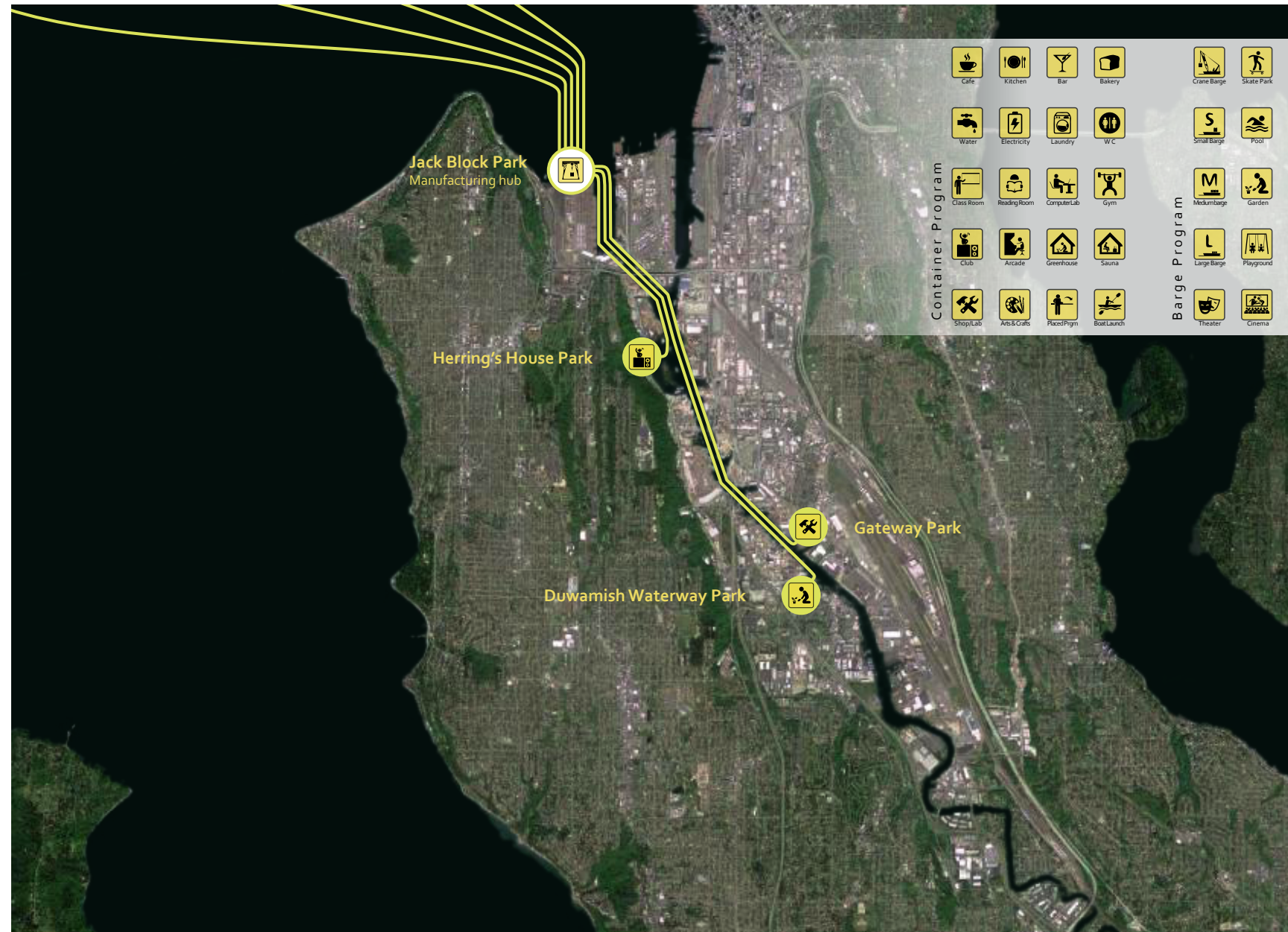

### How it works.

The hub would be a community based non-profit, having local members serve on a board to oversee and approve projects. Community based projects would come from surrounding communities who have particular sites in mind. Based on the community's input and what they envision, the manufacturing board would propose a series of barge and container configurations best suited for their site and program. After construction and assembly, the new deployable program is taken to its site. Depending on its success or failure, the barges are added to or swapped out to fulfill the client's needs.

Each community-based client would be a permanent member of the manufacturing hub. Clients would meet at the hub to discuss the potential for future deployment and assemblies dependent on season, use, and or success. The example community-based discarded sites in this thesis are Herring's House Park, Gateway Park, and the Duwamish Waterway Park.

Commercial-based clients such as Boeing, Microsoft, and so on would have the ability to pick and choose a configuration of their choice depending on the event being held. For example, Boeing wants to hold a summer party for their employees. Boeing would have the option of ordering a pool barge, restaurant, and an event space with the ability to entertain the desired amount of people. As a result of serving private clients, funds could be raised which would enable communities to reinvest into these sites and the surrounding infrastructure.





## Herring's House Park

Herring's House Park has historic and sentimental ties to the Duwamish tribe in the area. Across from the Duwamish Longhouse and Cultural Center Herring's House Park has walking trails with views of the Duwamish River. The program placed would be to reconnect or provide space for a disenfranchised gay community and the unrecognized duwamish tribe.

The programs would be event based, a pool and sauna to attract people to the area, a club for the disenfranchised gay community, a boat launch for kayaks, educational kitchen to teach the community about healthy foods and a cafe.

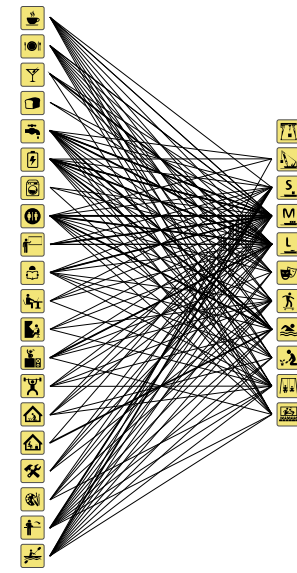
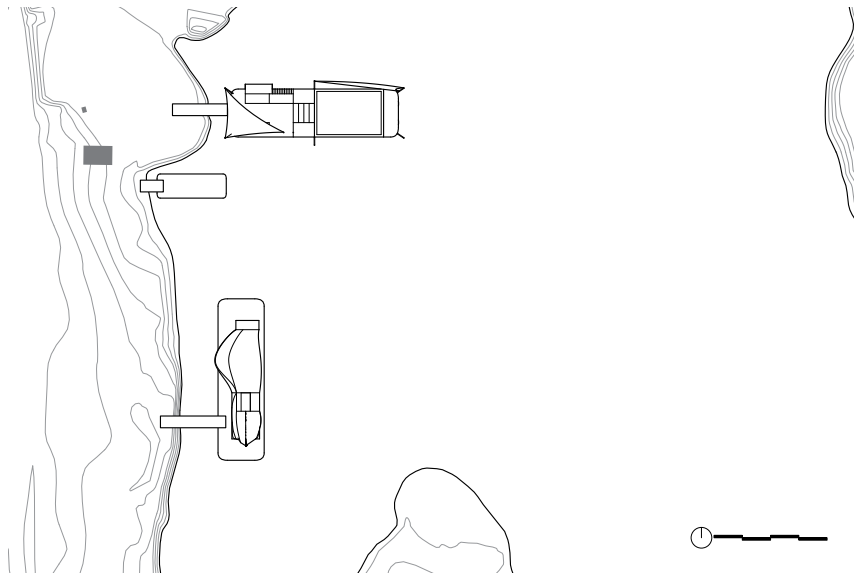

Program

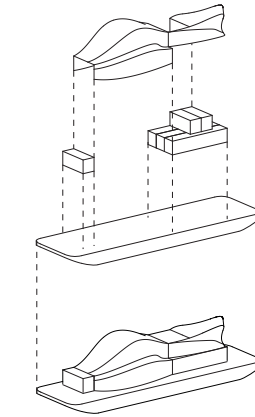

Massing

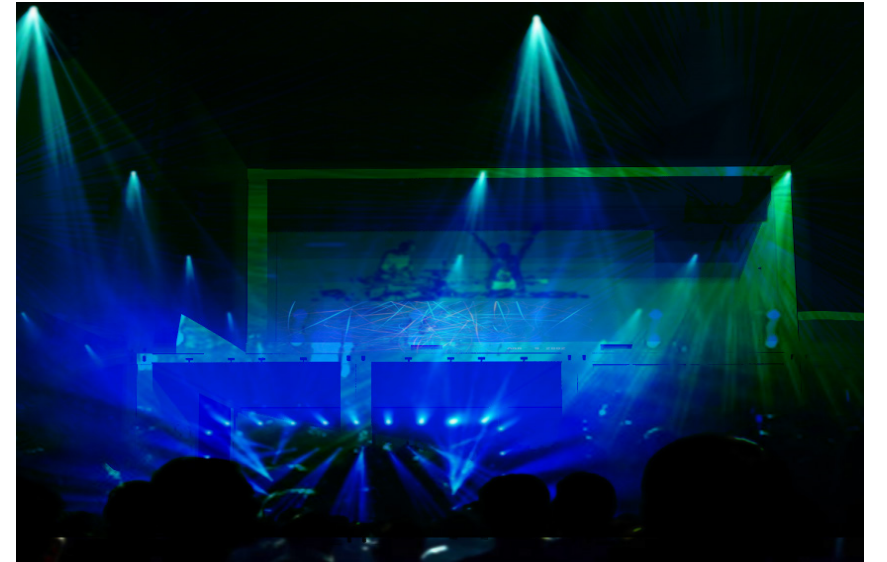

Club Interior



### Gateway park

Gateway Park is in the highly industrialized area of Georgetown and the only water access the community. The program placed would focus on providing space for both the industry and the community of Georgetown in hopes of creating new social circle to better the surrounding area.

Ideal program would consist of a maker lab for local craftsmen, a cafe and bakery for the morning industry workers in the area, a club/bar to enhance the nightlife in the area, skate park and arcade for the youth in the area, and community infill which allows the community members to open small businesses or just occupy space.

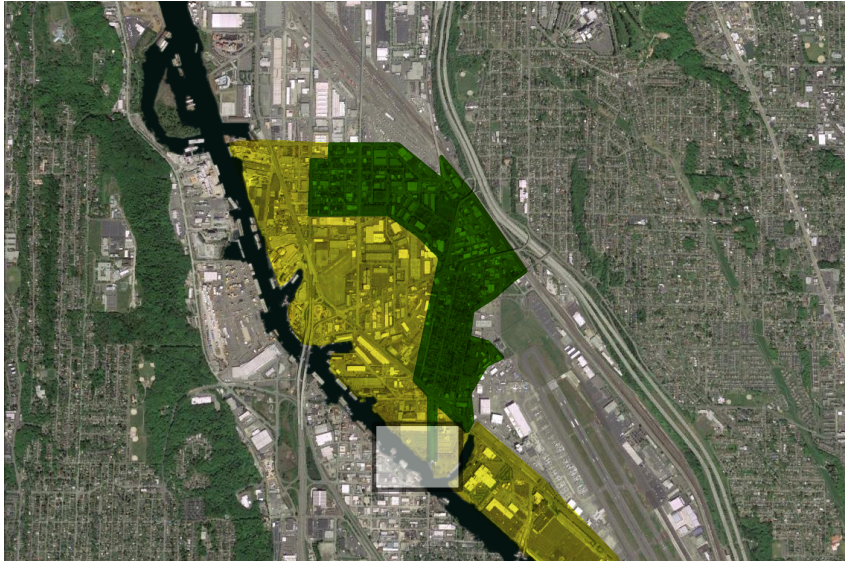
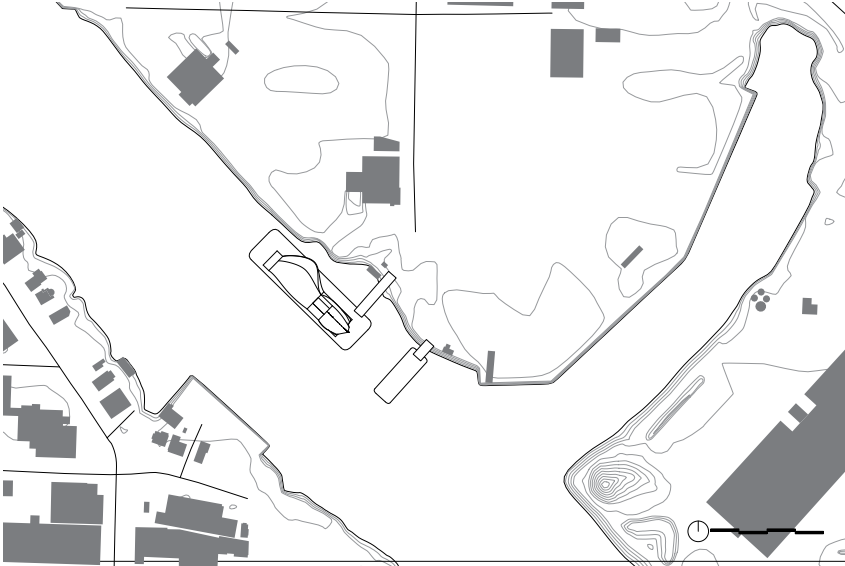

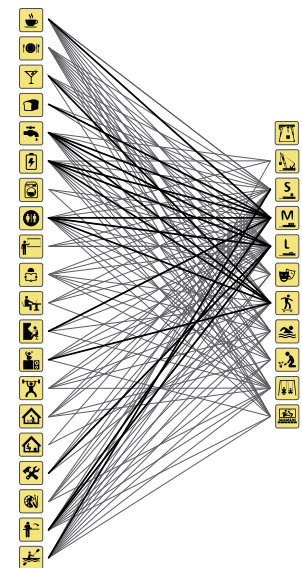

Program

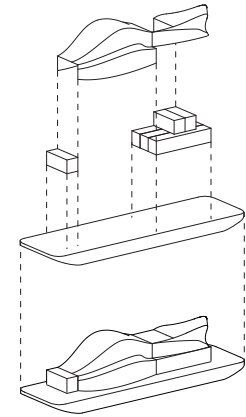

Massing



Cafe Interior



Possible Program

Rendered Program

## Duwamish Waterway Park

The Duwamish Waterway Park is tucked in the residential neighborhood of South Park. While visiting this site I ran into a father of four while he was playing with his kids and I asked him what kind of amenities would he like to see in the area. He said he liked south park because it was Seattle's little secret, a small quiet neighborhood and he didn't want anything to attract any attention to it...

Keeping this in mind and considering the contaminated soil in the area from decades of industrial use the program placed would be farm and food focused. Greenhouses for planting year round, gardens for the surrounding community, educational kitchen to teach the community about healthy foods, and a restaurant to serve the neighborhood.

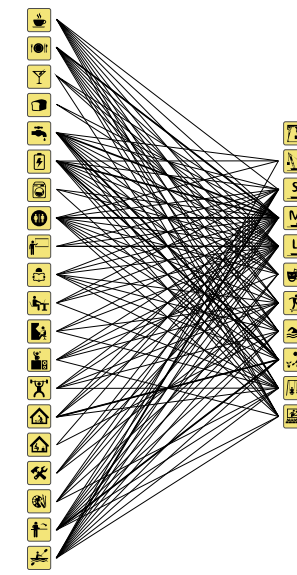

Program

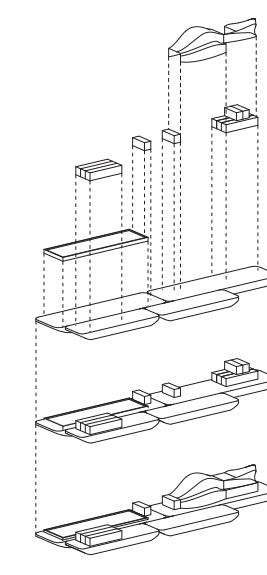

Massing



Greenhouse Interior

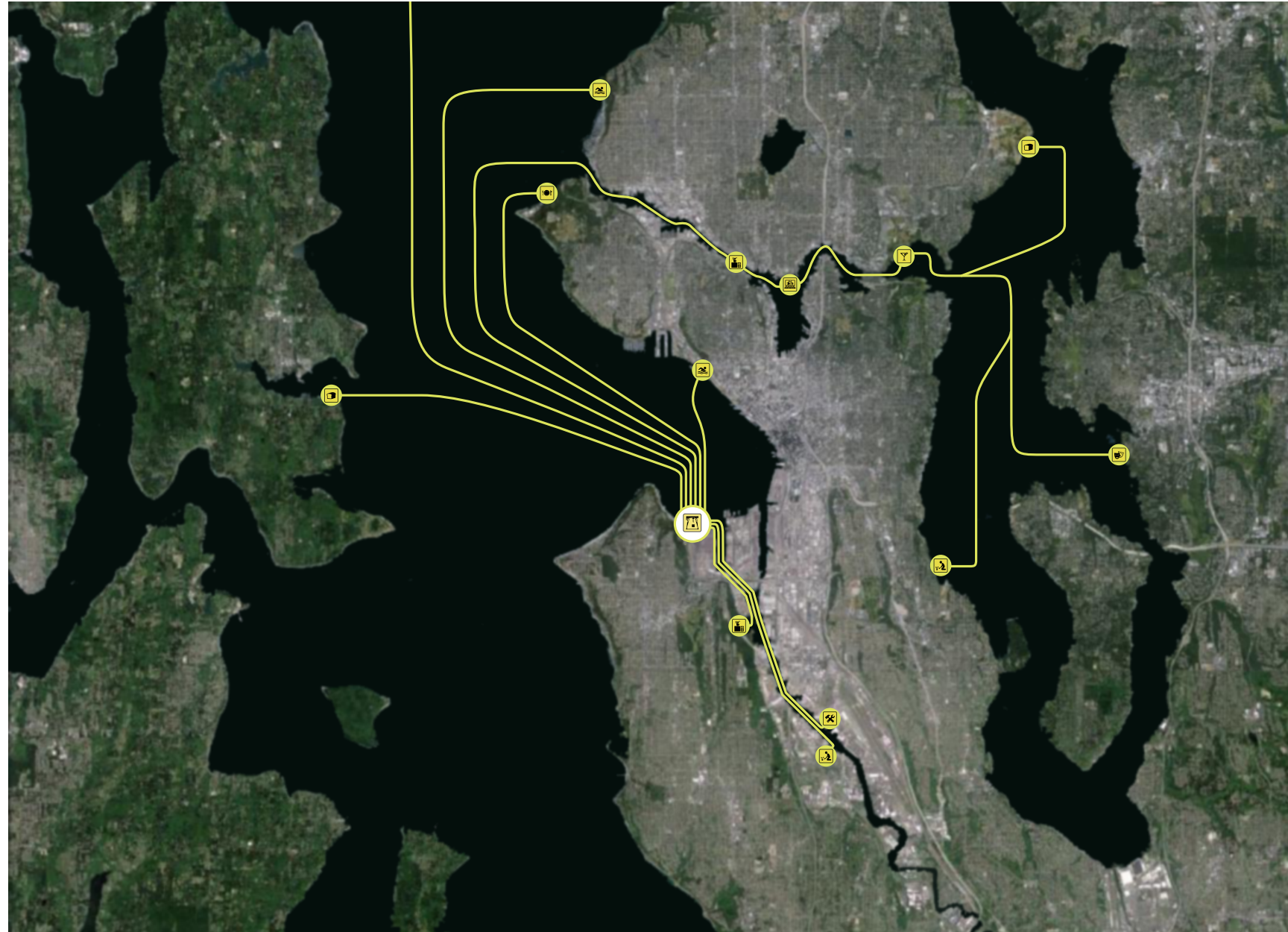

## Conclusion

The insertion of a new industry based on importing and exporting experience economies along the Duwamish Waterway in an effort to reintroduce the surrounding communities to its shores is the focus of this thesis. The creation of heterotopia, other spaces, for surrounding communities of the Duwamish gives local businesses and residence the ability to take control of discarded sites and capitalize on them. Find a use where others might see uselessness.

The three sites chosen have one similarity, the lack of use, communities cut off by industry, pollution, and even not having knowledge of them. By introducing adaptable program placed on moving barges these sites have the advantage of being able to change, move, succeed and even fail in order to find the full potential of the site and its use. Whether the barges are fixed or cyclical depending on season the program placed would be a heterotopia, neither here nor there.

The communities would own these barges which in turn would create social responsibility to these sites. Amit Ittyerah of LMN Architects had a great idea during my mid-review, that these communities would be able to lease out the barges to provide a income for the neighborhoods. Even better he suggested just go out like pirates and roam the shores of privileged neighborhoods in order to educate the greater Seattle area about the Duwamish Waterway.

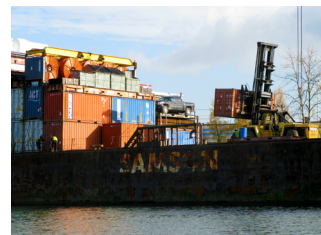
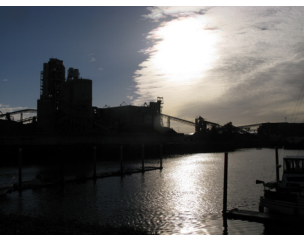
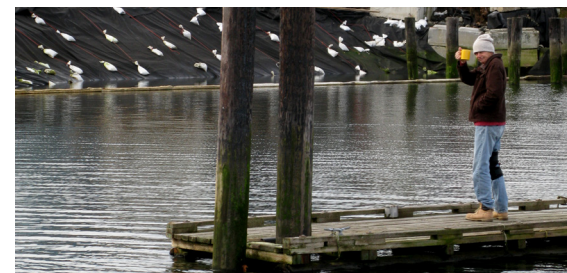
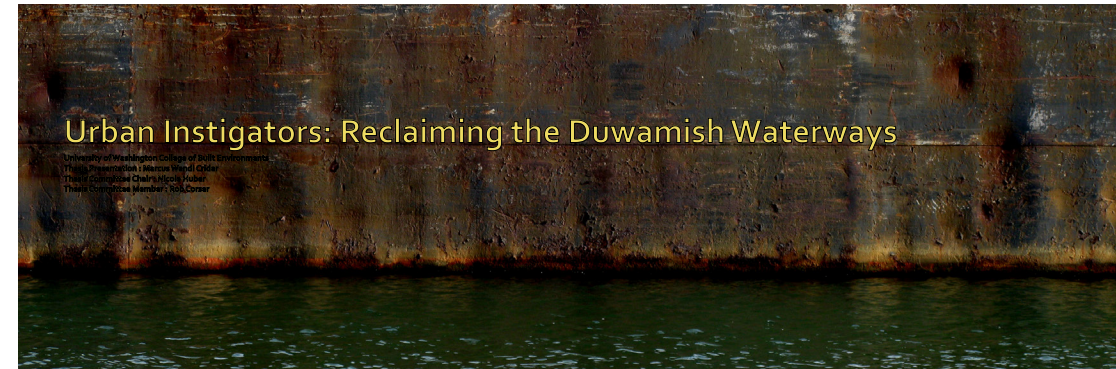

## Bibliography

Baird, George. *Public Space: Culture'Political Thory; Street Photography ; an Interpritation*. Amsterdam : SUN, 2011. Web. 20 Apr. 2013.

Bell, Bryan. *Good Deeds, Good Design : Community Service Through Architeture*. New York : Princeton Architectural Press, 2004. Web. 20 Apr. 2013

*Barges for sale*, Maritime Sales Inc, 2010, Feb. 24 2014,  
<<http://www.maritimesales.com/barges%20for%20sale.htm>>

Cramer, Johannes. *Architecture in Existing Fabric : Planning, Design, Building*. Basel (Switzerland) ; Boston : Birkhauser, 2007. Web. 20 Apr. 2013.

Cuff, Dana. *Fast-forward Urbanism : Rethinking Architecture's Engagement with the City*. New York : Princeton Architectural Press, 2011. Web. 20 Apr. 2013.

Cuff, Dana. *The Provisional City : Los Angeles Stories of Architecture and Urbanism*. Cambidge, Mass. : MIT Press, 2000. Web. 20 Apr. 2013

*Culture and History*, Duwamish Tribe, 2011, Feb. 24 2014,  
<<http://duwamishtribe.org/culture.html>>

Duwamish Industrial Lands Study, Department of Planning and Development, Nov. 2013, Feb. 2014,  
<[http://www.seattle.gov/dpd/cs/groups/pan/@pan/documents/web\\_informational/p1903847.pdf](http://www.seattle.gov/dpd/cs/groups/pan/@pan/documents/web_informational/p1903847.pdf)>

Fletcher, Mark. *Islands : Contemporary Architecture on water*. Konigswinter, Germany : H.Fullmann, 2009. Web. 20 Apr. 2013.

Gauzin-Muller, Dominique. *Sustainable Architecture and Urbanism : Concepts, Technologies, Examples*. Basel; Boston : Birkhauser, 2002. Web. 20 Apr. 2013

## Bibliography

- Gehl, Jan. *Life Between Buildings : Using Public Space*. New York : Van Nostrand Reinhold, 1987. Web. 20 Apr. 2013.
- Hilderbrand, Grant. *Designing for Industry : the Architecture of Albert Kahn*. Cambridge, Mass. : MIT Press, 1974. Web. 20 Apr. 2013.
- The Lower Duwamish Waterway*, Lower Duwamish Waterway Group, 2013, Jan. 20, 2014.  
<<http://www.ldwg.org/>>
- Lower Duwamish Waterway Superfund Site*, U.S. Environmental Protection Agency. Feb. 15 2014, Feb. 24 2014,  
<<http://yosemite.epa.gov/r10/cleanup.nsf/sites/lduwamish>>
- The Duwamish Vision*, The Duwamish River Cleanup Coalition, 2014, Feb. 24 2014,  
<<http://duwamishcleanup.org/?s=vision+plan>>
- Martin Craig, *The Shipping Container*, The Atlantic, Dec. 2 2013, Feb. 24 2014,  
< <http://www.theatlantic.com/technology/archive/2013/12/the-shipping-container/281888/>>
- Munce, James F. *Industrial Architecture; An Analysis of International Building Practices*. New York, F.W. Dodge Corp., 1960. Web. 20 Apr. 2013.
- Pallasmaa, Juhani. *The Eyes of the Skin : Architecture and the Senses*. New York: Wiley, 2013. Ebook Library. Web. 20 Apr. 2013.
- Powell, Ken. *City Reborn : Architecture and Regeneration in London*, From Bankside to Dulwich. London : Merrell. 2004. Web. 20 Apr. 2013
- Standard container, Job Site Express, 2014, Feb. 24 2014,  
<<http://www.jobsiteexpress.com/servlet/the-124695/4oGP-NEW-Standard-Container/Detail>>

## Bibliography

- Scheuermann, Rudi. *Tensile Architecture in the Urban Context*. Oxford; Boston : Butterworth Architecture, 1996. Web. 20 Apr. 2013
- Straightening of The Duwamish River*, History Link, 2014, Feb. 24 2014,  
<[http://www.historylink.org/index.cfm?DisplayPage=output.cfm&File\\_Id=2986](http://www.historylink.org/index.cfm?DisplayPage=output.cfm&File_Id=2986)>
- Pro Parks Levy*, Seattle Parks and Recreation, 2014, Feb. 24 2014,  
<<http://www.seattle.gov/parks/proparks/>>
- Waldrep, Shelton. *The Dissolution of Place : Architecture, Identity, and the Body*. Farnham: Ashgate Publishing Ltd, 2012. Ebook Library. Web. 20 Apr. 2013.
- Winter, John. *Industrial Architecture : A Survey of Factory Building*. London, Studio Vista, 1970. Web. 20 Apr. 2013.
- What's in the River?*, Duwamish River Cleanup Coalition, 2014, Feb. 24 2014,  
<<http://duwamishcleanup.org/home/whats-in-the-river/>>
- What is Superfund?*, U.S. Environmental Protection Agency, Dec. 24 2013, Feb. 24 2014,  
<<http://www.epa.gov/superfund/about.htm>>
- Yaneva, Albena. *Mapping Controversies in Architecture*. Farnham: Ashgate Publishing Ltd, 2012. Ebook Library. Web. 20 Apr. 2013

## Image Bibliography

all other images where taken or created by Marcus Wendl Crider



Reese Tom, *Hope For The Duwamish*, 2014, Feb. 24 2014, < <http://www.tomreesephoto.com/index.php#mi=2&pt=1&pi=10000&s=1&p=1&a=o&at=o>>



Archive, Duwamish River Cleanup Coalition, 2014, Feb. 24 2014, < <http://duwamishcleanup.org/2010/12/>>



Ryder David, *Duwamish Pollution*, 2014, Feb. 24 2014 < <http://www.photographer-in-seattle.com/duwamish-pollution/>>



Special Collections, The Seattle Public Library, 2014, Feb. 24 2014, < <http://cdm16118.contentdm.oclc.org/cdm/>>



*A Closer Look at the Duwamish Tribe*, All A bout South Park, 2014, Feb.24 2014, < <http://allaboutsouthpark.com/live/history/duwamish-tribe-history/>>



*The view from the Ishii family farm, ca. 1935*, The Seattle Times, Nov. 12 2012 , Feb. 24 2014, < [http://seattletimes.com/html/pacificnw/2019630871\\_pacificpdorp18.html](http://seattletimes.com/html/pacificnw/2019630871_pacificpdorp18.html)>



*EPA Unveils Options For Duwamish Cleanup*, The Seattle Times, Dec. 29, 2010, Feb. 24 2014, < [http://seattletimes.com/html/localnews/2013788857\\_duwamish29m.html](http://seattletimes.com/html/localnews/2013788857_duwamish29m.html)>



*Seattle Now & Then: Coming Home To Riverside*, Dorpat Sherrard Lomont, 2014, Feb. 24 2014, <<http://pauldorpat.com/2012/01/21/seattle-now-then-coming-home-to-riverside/>>

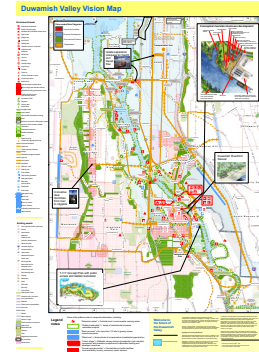

Duwamish Valley Vision Map, Duwamish River Cleanup Coalition, 2014, Feb. 24 2014, < <http://duwamishcleanup.org/programs/the-duwamish-vision/>>

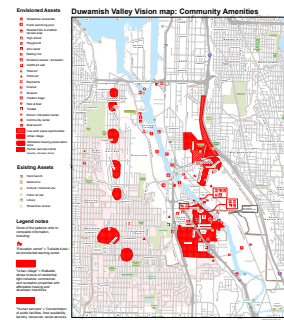

Duwamish Valley Vision Map, Duwamish River Cleanup Coalition, 2014, Feb. 24 2014, < <http://duwamishcleanup.org/programs/the-duwamish-vision/>>



Company Profile, XLNT Information Processing Technology India Pvt. Ltd., 2014, Feb 24 2014, < <http://xlntsolutions.in/FLIndex.htm>>

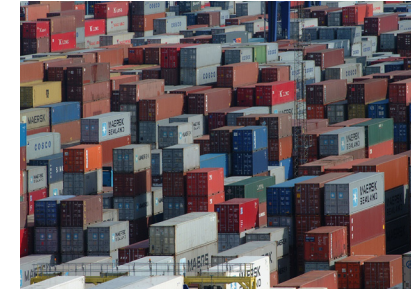

Container Yard Port Of Felixstowe - Reference: #NC132-27170, Fansshare, 2014, Feb. 24 2014, <[http://img27.fansshare.com/pic132/w/container-security-initiative/369/27170\\_container\\_yard\\_port\\_of\\_felixstowe.jpg](http://img27.fansshare.com/pic132/w/container-security-initiative/369/27170_container_yard_port_of_felixstowe.jpg)>



Barge Freight, MBLX River Logistics Made Easy, 2014, Feb. 24 2014, < <http://mblx.com/services/barge-freight>>



Richmond Barge Service Adds Third Sailing: Tuesday, Thursday and Saturday, The Port of Virginia, Oct. 2 2012, Feb. 24 2014, < <http://blog.portofvirginia.com/my-blog/2012/10/richmond-barge-service-adds-third-sailing-tuesday-thursday-and-saturday.html>>

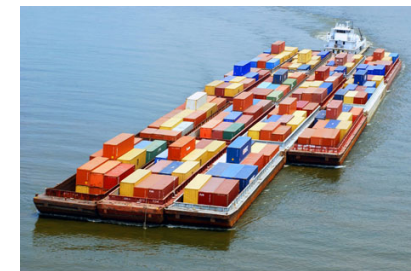

Osprey sets inland waterway box record, Marine Log, Aug. 8 2005, Feb. 24 2014, < <http://www.marinelog.com/DOCS/NEWSMMV/2005aug017.html>>