

Bike Touring Infrastructure:

An Architectural Proposal for Sustainable Bicycle Tourism.

Michal M. Okonski

A thesis
submitted in partial fulfillment of the
requirements for the degree of

Master of Architecture

University of Washington
2016

Chair:
Robert Peña
Committee:
Kimo Griggs
Kathrina Simonen
Penelope West

Program Authorized to Offer Degree:

Architecture

© Copyright 2016
Michal M. Okonski

University of Washington

Abstract

Bike Touring Infrastructure: An Architectural Proposal for Sustainable Bicycle Tourism.

Michal M. Okonski

Chair of the Supervisory Committee:
Associate Professor Robert Peña
Department of Architecture

America has had a century long obsession with automobiles. The United States has become synonymous with car travel and road trips. But climate change challenges us to rethink these relationships and consider alternative modes of travel and transit. Known as the place for innovation and reinvention, the time is ripe for the US to reinvent its identity as the destination for environmentally savvy 21st century travelers.

Using the bicycle as a platform for driving eco-tourism, this project proposes an infrastructure to support bicycle tourism. The project examines Washington State as a potential case study for bicycle tourism and proposes to build onto existing infrastructure to drive rural economic development. The project looks into the the physical demands of cyclists as well as the cyclist's needs while traveling long distances.

Through research about bicycle history, geography, nutrition, and economics, the project offers insight into bike touring and bicycle tourism. Many interviews were conducted to depict varying perspectives of bicycle tourism from individual cyclists to bicycle advocacy.

Based on the research conducted, the project proposed shelters at regular intervals to offer services for cyclists traveling along specific bicycle routes within Washington State. These shelters allow cyclists to travel safely through the region with peace of mind that services are available and they have a safe place to stay every night. Further, the project proposes to create an identity for safe travel within the region as well as to create an international draw for visitors to experience America by bicycle.

The project conclusion offers further research opportunities, next steps for deployment as well as general project observations. Additionally, it summarizes many of the important points to success within the project.

Acknowledgements

First, I would like to thank my chair and committee for their support and effort in this project. Rob, Kate, Penelope and Kimo – I appreciate your willingness to be involved and all of the advice you have given.

I would like to thank the University of Washington and the Department of Architecture. I believe that the education I have received has changed my life and will forever continue to enrich my wellbeing.

I would like to thank my wife Megan. The sacrifices you made for my education and our future will forever be remembered. I hope the sacrifices we have made will lead us to a lifetime of happiness.

Table of Contents

Preface	6
1: Bicycle History	7
2: The Modernity of Bicycles	22
3: Bicycle Touring	30
4: Bicycle Touring Amenities	42
5: Profiles of Cycling Tourists:	60
6: The Human Cyclist	67
7: The Economics of Bicycle Travel	73
8: Site Analysis	80
9: Methodology	98
10: Architecture	116
11: Conclusion	149
12: A Short Story	150
Works Cited	159
Figures	164
Additional Acknowledgements	169

Preface

Prior to proposing an architectural project, it is wise to do an appropriate amount of research. We must make informed decisions as designers of the built environment. The larger the project, the more we should study its implications. But, even a small project should follow logic.

The next generation of designers will be scrutinized more than previous generations. As the world changes around us, responsible designers will become outliers and lead the way for others. History reveals landmarks in innovation as well as our failures. History will be the ultimate judge, so we must think in terms of the audience of tomorrow.

Chapter 1:

Bicycle History

The Rise of Bicycles.

The exact origins of the bicycle are not known. This first evidence of the machine was in the early 1800s. In 1817, Charles (Karl) Baron von Drais of Sauerburn applied for a patent for a wheeled device that could be steered and had a padded saddle. The patent was granted in 1818 and he took his invention to Paris where it acquired the name velocipede. It should be stated that this design had equal size wheels, unlike designs that would follow. Over the next few years the popularity of the machine grew and spread to England. Coachmakers began producing velocipedes due to market demand.¹

In the United States, the first patent for a velocipede was granted in 1819. However, the contents of the patent are unknown due to the Patent Office Fire of 1836. There is little evidence of the popularity of the machine in the US at this time.²

In Europe, inventors were experimenting with different designs. In 1839, a Scottish blacksmith named Kirkpatrick Macmillan was credited for developing the first drivetrain on a bicycle. It was pedal driven, but otherwise it did not resemble the chain system of today. Macmillan's design was similar to a steam locomotive, which had a crank fixed to the rear wheel and fixed rods connecting to the pedal at the front of the bicycle. Through this period inventors experimented with unequal wheel sizes.¹

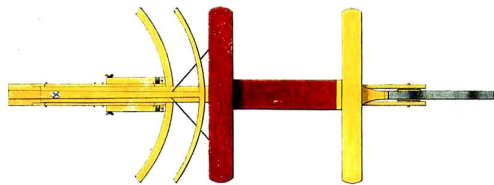
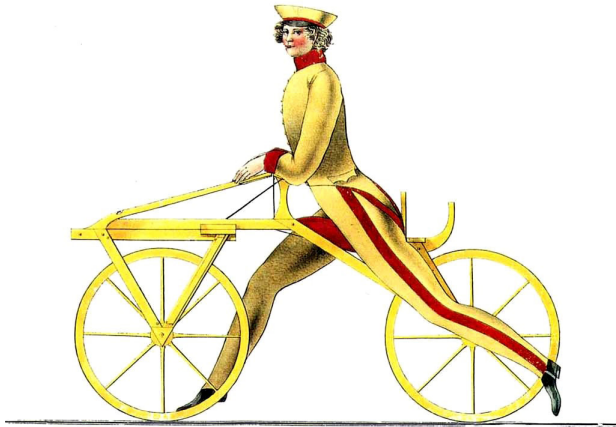

Figure 1: An Illustration of the Draisine of 1817

The next milestone in velocipede development occurred in 1863 with the addition of pedal to a large front wheel. Further improvements occurred in the coming years. Pierre Michaux was a notable figure who began the first company to mass produce bicycles. During this period, wooden frames were dropped in favor of cast iron. Soon afterwards, wrought iron was adopted.³ By 1868 the US was showing signs of enthusiasm for the device. Riding schools were established in many eastern US cities. Numerous coachmakers manufactured the machines. Sporting races occurred at Harvard and Yale among students. This era would become known as the “velocipede craze.” By 1869 the term bicycle became a common name for the device.² In the US the term “bone shaker” was shortly used due to the stiff and unforgiving ride of the machine.

During the 1870s US development and enthusiasm for the bicycle was at a standstill. In England, incremental developments were being made. This period became known for the “high-wheel” bicycle design, and in England it was called “penny-farthing.” This bicycle design is credited to Eugene Meyer, who’s design used a wire spoke wheel he invented. The bicycle design featured a large front wheel and a relatively small one in the rear. Although wheel sizes have changed since then, wire spoke wheels are still common today.⁴



Figure 2: An Illustration of an American Velocipede circa 1869



Figure 3: Ordinary Bicycle circa 1870s

In 1871, James Starley introduced the Ariel bicycle design, later called the “Ordinary,” due to its popularity and commonality. Starley improved Meyer’s wire wheels by making the spokes tangential. His design featured the common high-wheel design of the era with improvements to the wheels and added a mounting step. Mr. Starley would later invent significant devices such as differential gears and the perfection of the chain drive.⁴

In the middle of the 1870s the US became interested in bicycles again. The machines were being imported from England. In 1878, Albert A. Pope began the first bicycle manufacturing company in the US called “Columbia.”² He soon gained control of nearly all applicable patents relating to the bicycle. He took his competitors to court and forced them to pay royalties or forced them out of business. Pope’s contributions would have a very wide spread affect on the world. Pope was an early pioneer of mechanization and mass production, vertical integration and aggressive advertisement. Ford Motor Company and General Motors would later adopt these practices to great success. It was also during this time of production development that Western Wheel Company of Chicago introduced stamped metal parts instead of machined parts, which again began very influential.⁶ Lastly, it was at this time that bicycle manufacturers introduced annual model change, or planned obsolescence, which proved very successful. This process would be later credited to General Motors.⁷

The high wheel era led users to be concerned with safety due to the design's inherently dangerous tall front wheel and fixed pedaling on that wheel. The "safety" design that followed became arguably one of the most important contributions to bicycle history.

John Kemp Starley, nephew of James Starley, began producing bicycles under the name Rover in 1883. In 1885, he made a significant contribution with the introduction of the Rover Safety Bicycle. The notable features of the model were two similar sized wheels, a rear wheel chain driven drive chain and front wheel steering with caster (steering angle). This design was more stable and easier to ride than a high wheeler. This model became the new standard and widely imitated. Shortly after the "diamond" frame design was developed. This would later lead to the "double diamond" design used today.⁵



Figure 4: Rover Safety Bicycle



Figure 5: Dunlop Pneumatic Tires

Shortly after, in 1888, John Dunlop introduced pneumatic tires on a bicycle which improved comfort considerable.³ Along with the development of the safety bicycle design, these inventions revolutionized bicycles and personal travel forever. Pneumatic tires are now a standard feature not only on bicycles but cars, planes, and most machines that ride over asphalt.¹⁰

The 1890s saw the most significant bike boom to date. This period became known as the “Golden Age of the Bicycle.” It is estimated that there were 10 million bicycles in the US in the 1890s and the population at that time was 75 million. Bicycles were also widely popular in Europe around this time. The four major developments of that era were safety, steering, comfort and speed.⁸

The significance of the bicycle during this time should not be underestimated. As manufacturing processes allowed for more affordable bicycles, the common man could now own reliable and inexpensive transportation. But beyond this demographic, the safety bicycle emancipated women and gave them unprecedented mobility and freedom.



Figure 6: Golden Age of Bicycles circa 1890s

Let me tell you what I think of bicycling. I think it has done more to emancipate women than anything else in the world. It gives women a feeling of freedom and self-reliance. I stand and rejoice every time I see a woman ride by on a wheel... the picture of free, untrammelled womanhood.

- Susan B. Anthony

The Wright Brothers and the Shift from Bicycle Manufacturing



WE HAVE THEM!

\$150 Bicycle for	\$150
\$150 " "	\$150
\$150 " "	\$110
\$180 " "	\$85
\$135 " "	\$70

BARGAINS IN CHEAP WHEELS.

Do not forget "Dunlap" and "Warwick" detachable tires and hollow rims. Most \$150 wheels do not have them, ours do. Come and see them.

WRIGHT CYCLE EXCHANGE,
1016 WEST THIRD ST.,
Between Williams and Baxter.

Figure 7: Wright Cycle Exchange circa 1893

In 1892, Wilbur and Orville Wright bought “safety” bicycles and developed a passion for them. They had other bicycle models prior including an “ordinary” high-wheeler, but when Orville bought a new Columbia Safety bicycle for \$160, Wilbur quickly bought a used Eagle Safety for \$80. They toured on these bicycles around the country and Orville occasionally raced bicycles.⁹

In the same year, The Wrights opened the Wright Cycle Exchange in Dayton, Ohio. Their bike shop carried many bicycle brands. By 1895, they began to manufacture their own bicycles for sale; their most notable model was the “Van Cleve.” They also invented the self-oiling hub and pedals they didn’t unscrew.

In 1897, their most profitable year, they each made \$1500. The average salary at the time was \$500. Their profits allowed them to save money to experiment with their hobby and interests in flying machines.

In 1898 then Assistant Secretary of the Navy, Theodore Roosevelt, convinced the War Department to pay \$50,000 to Samuel Langley to develop his 1896 Aerodrome into a machine capable of carrying a man. This was the largest sum to date the War Department paid for developing a weapon. Word was leaked and reached the Wright brothers.

Between 1900 and 1901, the Wrights had two unsuccessful glider attempts. In 1902, Wilbur told a friend that bicycle manufacturing was in decline and they were looking for other lines to manufacture.

In 1902, the Wrights successfully flew their glider and made aeronautical breakthroughs that kept them focused on airplanes. They made very few bicycles that year and by 1904, they stopped manufacturing them completely.

In 1909 they sold their first airplane. Their bike shop was then converted into a machine shop to produce parts for their planes. This same year they sold their remaining bicycle parts as well as the rights to their bicycle models to M.F. Meyers who continued to use the name of the Van Cleve on bicycles made by another company.

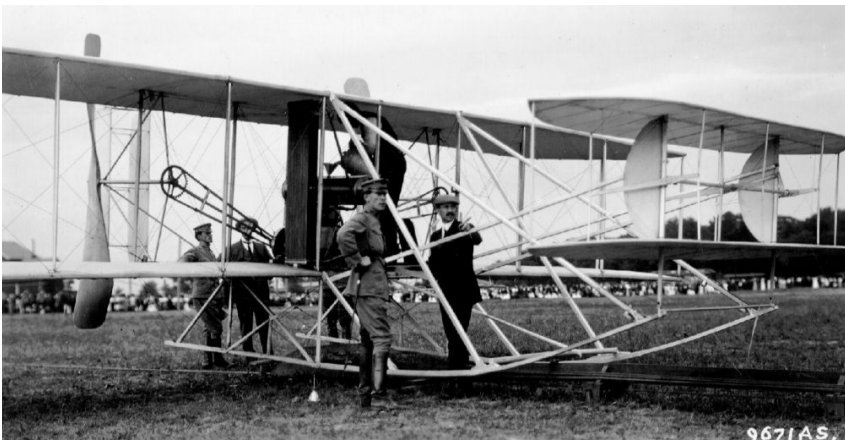

Figure 8: Wright Military Flyer circa 1909

In 1891, Henry Ford became an engineer for the Edison Illumination Company and was promoted to chief engineer in 1893. This gave him enough resources to experiment with his personal hobby of gasoline engines. In 1896, he completed and successfully test drove the Ford Quadricycle. This machine consisted of a simple frame, four bicycle wheels and an ethanol engine. Thomas Edison approved of the machine and encouraged him to experiment and develop it further.¹²

In 1901, the Detroit Automobile Company formed the Henry Ford Company in which Henry Ford was the chief engineer. However, shortly after Ford left the company and it was later renamed Cadillac Automobile Company.

Through various deals with the Dodge Brothers and others, the Ford Motor Company was established in 1903. That same year Ford introduced a new car which would later set a new land speed record at 91.3 mph. The car was named the “999” by race car driver Barney Oldfield. He then took the car around the country to promote the Ford brand.¹³

The Ford Model T.



Figure 9: The Ford Model T

The world changed forever in 1908 when Henry Ford introduced the Model T. The assembly line production that Ford developed allowed the vehicle to be economical for the common man with a mere \$850 price tag. The car became prized for being economical, durable, versatile, and easy to work on. At one point, the Model T made up about 40% of all cars sold in the US. The Model T was in production from 1908 until 1927 and 15 million units were built. The record stood for 45 years until the Volkswagen Beetle surpassed it. By 1925 the touring version of the Model T was under \$300.¹¹

The Good Roads Movement



GOOD ROADS BUILDING. Erected by the State of Washington.

As cities began to have paved roads, the roads between cities were dirt, gravel, or mud, making rural travel uncomfortable. Beginning in the late 1870s a group led by cyclists began advocating for improved roads. They looked to Europe for guidance where local and state governments supported roadway construction and maintenance. In 1880 the Good Roads Movement was founded through the formation of the League of American Wheelman, which consisted of a group of bicycle enthusiasts, manufacturers and riding clubs. Groups toured the country to educate and advocate on the benefits of good roads. They became involved in local politics and published literature such as *The Gospel of Good Roads*.¹⁴

In 1893, the US Department of Agriculture began systematic evaluation of existing highway systems. This was the same year that the first gas powered automobile design was invented. Soon other companies and organizations began lobbying for better roadways.

From the group's influence and efforts, roadway conditions became a major concern. In 1916, President Woodrow Wilson signed the Federal Aid Road Act of 1916.¹⁵

Figure 10: Good Roads Building During the Alaska Yukon Expedition

In 1916, the early form of the Federal Aid Road Act helped paved the infrastructure for the new explosion of cars in the United States. Further refinement occurred in the Federal Aid Highway Act of 1921. This Act built and organized interstate roadways into a manageable and navigable system. New car owners could now crisscross the country on well-paved roads from one state to another. The economy of these travelers changed the landscape with gas stations, diners, and motels sprouting up along the new roads.¹⁶

The US Interstate System



Figure 11: US National Highway System

Further development of the interstate roadways system came with the authorization of the Federal Aid Highway Act of 1956. At the time this was the largest public works project in US history. The act originally authorized \$25 billion to construct 41,000 miles of Interstate Highway and was supposed to take 10 years to construct. The act was also known as the National Interstate and Defense Act for a few reasons. Much of the funds for the project came from defense funds. Additionally, the system was designed to give National Air Force Bases direct access to roadways in case of an attack on the nation. Coincidentally, 1956 was also the same year that the Federal Fuel Taxes were introduced which would fund highway construction projects.¹⁷

There have been many iterations of Highway Acts over the past 100 years. As of 2013, the US Interstate system is the second largest in the world after China's system. The US system has almost 48,000 miles of roads. The estimated cost for the system is \$425 billion, in 2006 dollar equivalence.¹⁸

In 1946, Edwin J. Quinby, founder of the Electric Railroaders' Association, published a letter exposing a plot for GM to monopolize and dismantle the streetcar system. The letter depicted the intricate ownership structure of GM's subsidiary, National City Lines, which by 1947 owned 46 systems in 45 cities in 16 states. Despite the letter, the federal government began investigating NCL's financial arrangements in 1941. However, in 1947, nine corporations were indicted in the Federal District Court of Southern California on counts of "conspiring to acquire control of a number of transit companies, forming a transportation monopoly" and "conspiring to monopolize sales of buses and supplies to companies owned by National City Lines."¹⁹

In 1949, Firestone Tire, Standard Oil of California, Philips Petroleum, GM and Mack Trucks were convicted of conspiring to monopolize the sale of buses and related products to local transit companies controlled by NCL. However, they were acquitted of conspiring to monopolize ownership of these companies.²⁰

The GM Street Car Conspiracy



Figure 12: Decommissioned Street Cars circa 1940s

In 2010, CBS' Mark Henricks reported:

*There is no question that a GM-controlled entity called National City Lines did buy a number of municipal trolley car systems. And it's beyond doubt that, before too many years went by, those street car operations were closed down. It's also true that GM was convicted in a post-war trial of conspiring to monopolize the market for transportation equipment and supplies sold to local bus companies. What's not true is that the explanation for these events is a nefarious plot to trade private corporate profits for viable public transportation.*²¹

In 1973, the Yom Kippur War started after Egypt and Syria launched a surprise military campaign on Israel to regain territories lost in the Six-Day War of 1967. The United States supplied arms to Israel shortly after the 1973 invasion. This led to the Organization of Arab Petroleum Exporting Countries (OAPEC) proclaiming an oil embargo against Canada, Japan, the Netherlands, the United Kingdom, and the United States.²²

The rising consumption and demand of oil by industrialized countries gave the OAPEC great leverage in this situation. The US was then the largest oil consumer in the world, and remains so today.

The US had a long tradition of producing oil leading up to this event. However, in 1970, supply decreased led to a rapid increase in oil importation in the US.

US Secretary of State Henry Kissinger negotiated the withdrawal of Israeli troops from the occupied region. The deal led to the OAPEC lifting the embargo in 1974.

Prior to the embargo, global oil prices were \$3 a barrel. By the end of the embargo a barrel of oil was \$12. In the US, gas prices began at 38.5 cents a gallon and by the end of the event were at 55.1 cents per gallon. The embargo also led to the stock market crash of 1973-1974.²⁴

The Oil Crisis of the 1970s



Figure 13: Leon Mill spray-paints a sign outside his Phillips 66 station

In 1974, the American Automobile Association (AAA) reported that 20% of gas stations were out of fuel. Gas stations began to ration out fuel in various ways. Violent incidents occurred when truck drivers chose to strike. In conservation efforts, a maximum speed limit of 55 mph was imposed, which would stand until 1995 when President Bill Clinton signed the National Highway Designation Act and ended the 55 mph limit. Further efforts were made through the Advertising Council using the tagline “Don’t be Fuelish.” The “24 Hours of Daytona” race was cancelled and NASCAR reduced all races by 10%.²³

In the aftermath of the event, many efforts were made to regulate and conserve energy sources. This also led to the awareness of alternative energy sources.

The bicycle never regained popularity after the turn of the century. No one could compete with the Model T. The car was made so affordable that now everyone could own the convenience and luxury of an automobile.

The bicycle gained slight traction during the Great Depression, but only because they were cheap and cheaper to maintain than a car. Order was restored once the market recovered.

Since the in 1950s, incremental increases have occurred in bike sales. In 1950, 2 million bikes were sold in the US. Interest in cycling increased and by 1970 7 million bikes were sold. The bike boom peaked in 1973 with 15 million bikes sold and 14 million in 1974. But, sales dropped to only 7 million in 1975. Time Magazine called this period the biggest wave of popularity in 154 years. And at the peak of the boom, more bicycles were sold than automobiles.

Despite the coincidental timing of this bike boom and the oil embargo of 1973, many argue that the boom was not the result of the embargo, only a contributing factor. Some attribute the bike boom to a few factors including innovations in bike design and culture shifts.²⁶

The Next Big Bicycle Boom



Figure 14: Schwinn Sting-Ray Bicycle circa 1963

In 1963 Schwinn introduced the Sting Ray, which became an overnight success. The model was geared towards kids and featured a fresh take on bicycle design. Inspired by kids in southern California who were customizing their bikes to resemble motorcycles, Schwinn brought the idea to market now every kid could have one. The Sting Ray featured a smaller front wheel, a long fork, ape-hanger handlebars and a banana seat. This gave it a “chopper” like appearance and screamed “I’m a badass!” so naturally every kid wanted one. Then in 1969, the movie Easyrider came out and this only added fuel to the fire.²⁵



Figure 15: Schwinn Varsity 10 Speed Bicycle circa 1970s

The other contributing factor to the bike boom was the 10-speed derailleur. This affordable device was fit onto many racing bikes which greatly expanded the potential of the bike. Further, the post World War II baby boomers were at the age where cheap transportation was in demand, and naturally they gravitated towards this new style of bike.

Of the 7 million bikes sold in 1970, 5.5 million were kids bikes and only 200,000 were of the 10-speed variety. However, of the 14 million sold in 1972, 5.5 million were kids bikes but the 10-speed market sought up to 8 million units sold.²⁷

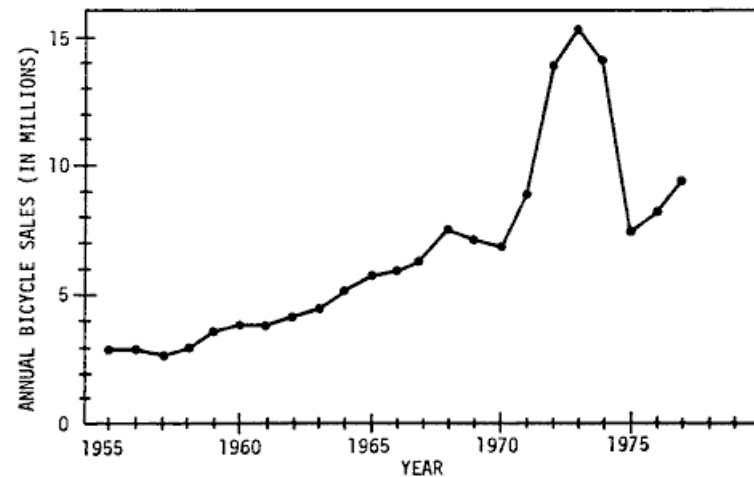

Figure 16: US Bicycle Sales between 1955-1977

Chapter 2:

The Modernity of Bicycles



Figure 17: Mountain bikes were 25% of bicycle sales in 2012.

Bicycle Sales Today

The peak of bike sales in the past twenty years was in 2000 with the sale of 20.9 million new bikes in the US. This does not include used bikes.²⁸

In 2014, 18 million new bikes were sold. The revenue generated in the bike industry that year through the sale of new and used bikes and accessories was \$7.4 billion.

In terms of cycling participation, in 2014, 35.5 million Americans, seven or older, rode bikes at least six times. However, peak cycling participation was recording in 1995 with 56.3 million Americans, but bike sales only amounted to 16.1 million new bikes sold.

Bicycling is the US 7th most popular recreational activity coming in just after bowling. Although recreational interests have been flat in recent years, there has been an increase in bike commuting and utility usage of bicycles. 73% of cyclists report riding for recreational use and 10% for commuting via bicycle, although many commuters don't report because they don't consider themselves "cyclists."

An estimated 2,000 companies are involved in bicycle manufacturing and distribution and roughly 150 brands to choose from.

In recent years, the mountain bike has done wonders for the industry. There was a small bike boom in the 1980s when this design of bike was introduced. In 2012, 25% of sales were of mountain bikes.²⁹

Since the 1970s boom, the bicycle industry has continued to make advancements in design, materials and parts. There has never been more options than there are today. Whatever the need, there is most likely a bike for it. It is not uncommon to see cargo bikes with families totting around kids, electric bike to help climb hills and convenient bikes that can fold down to the size of a briefcase and store under a work desk.

Although almost 130 years have passed since these great inventions, surprisingly little has changed since then. Sure we now have more gears than ever before, and the lightest materials imaginable, but the geometry and physics of bicycles have stayed roughly the same for over 100 years. There have been some notable exceptions such as the freehub, derailleur, mountain bike design and disc brakes. But in the world of cycle touring, these accessories are optional, and people are known to tour on just about anything.

It is worth noting however, that many bicycle manufacturers are picking up on the gaining popularity of the adventure cycling market. Some of the large manufacturers now offer touring models as well as bike-packing specific bikes. One noteworthy bicycle company that has made a niche for itself is Surly which is a QBP brand. Surly has catered many if not all of their models to be adventure bicycles. And at the top of the lineup is their Long Haul Trucker, which has gained much popularity amongst touring cyclists.



Figure 18: Surly Long Haul Trucker is a popular choice amongst touring cyclists in the US



Figure 19: Ford Advertisement circa 1924

The Elephant in the Room

There was a time when the bicycle was seen as a transportation vehicle. It took on many appearances, but at one point, people saw it as an alternative means of travel to a horse. Things clicked when the safety bicycle was invented. And at that point in history, millions of Americans were getting around by bicycle. Granted they were expensive, so only the affluent could afford them. But they were still less expensive than a car, which made them appealing.

When the Ford Model T appeared, it trumped the bicycle severely. By that point, bicycle sales had dropped dramatically. People saw the automobile as something to aspire to. They saw it as a luxury. It was, in a way, part of the American dream: to have a family, a home, and an automobile to take you places. The bicycle could never compete with this, and it lost miserably. In reality, the automobile would have had a tougher time catching on if it wasn't for some of the innovations and lobbying power behind the bicycle. But it mattered very little. It is hard to see what is in the rear view mirror when you're speeding along so swiftly. Once the automobile caught on, there was little that could stop it.

When the Great Depression occurred in the 1930s, people had little choice but to take up bicycles. Again, the 1970s, when the baby boomers took up 10 speeds, it was the most affordable transportation available. But public perception of the bicycle was low in both periods. Could you afford a car, you would not ride a bike. Given the choice, a car would always beat the bicycle. After all, how could you go out on a date with a 10 speed?

Since the turn of the century, the automobile has been directly linked to socioeconomic status and a symbol of success. In America, your car is an extension of your personality. To this day, this is still true. America is obsessed and addicted to cars. Prior to the 1970s oil shock, the bigger and less fuel efficient the car, the better. When you have all of the oil in the world, why not use it, right?

Well, surprisingly little has changed in recent years. Some are more vocal and conscious about climate change and the automobiles contribution to it, but we have more people in the US than ever before, and they all want a piece of the American dream.

And where does the bicycle fit into this? Statistically speaking, 85% of Americans of all ages have a positive view of bicycling. In 2006, 60 million Americans bicycled. In 2014, 18 million bicycles were sold, outselling cars by 1.5 million units. Despite this, there is an inconvenient truth about bicycles. 70% of Americans say they want to ride bikes, but only 18% do.³⁰ At some point

there is a disconnect between Americans and bicycles. Many factors play into this. Some have a fear of bicycling in public streets because they have been tailored for cars. There are social taboos associated with bicycles. Some believe that only those with DUIs ride bikes. Yet, there are those who would ride bikes if it were only more convenient.

But the greatest barrier of entry for the bicycle is its public perception as a recreational device, a toy for adults. We justify the bicycle by filing it under recreation, as a sport, and as a fitness device. Bicycles are marketed this way. Most bicycle manufactures design them like this. And public demand reinforces this notion. In statistical analysis, the bicycle lives in the recreational domain. And this is catch 22 of the situation. The bicycle is a significant contribution to the economy, but only as a recreational device.

A small minority of bicycle advocates see things differently. They see the positive economic impact in addition to increased health and wellness, as well as sustainable and efficient transportation in both urban and rural areas. Their biggest challenge is to sway the majority perception and misconception that bicycles are recreational toys for middle aged white men. Despite European countries discovering the many benefits of bicycles decades ago, the US is very slow in embracing the bicycle beyond recreation.

Urban v. Rural Cycling

Without a doubt there are more bicycle advocates and cyclists in general in cities than in rural areas of the US. As of the 2010 US Census, 81% of the US population live in urban areas.³⁶ So, it would make sense that the majority of cyclists are in cities. It would also be logical to assume that that is why the majority of cycling infrastructure is concentrated in urban areas. And this is how we should build cycling infrastructure in the US, from the cities out to rural areas and finally connecting to other cities.

But the riding experience from the city to the country is vastly different. Bike lanes, traffic lights for cyclists, greenways, and trails are a bit of a luxury when compared to what you get in the countryside. Even on a popular bike route, there may only be a few feet of debris scattered shoulder to ride on, and if you happen to hit a patch of rumble strips, forget about it. In a nutshell, rural infrastructure very primitive compared to urban infrastructure.

Bicycling outside America



Figure 20: Cyclists in Copenhagen

Outside the United States, the bicycle is seen as more than a recreational device. In fact, immigrants to the US are twice as likely to ride bicycles as people born in the Country. And should that immigrant come from a low-income high-density neighborhood, they are ten times as likely to ride a bike as someone born in the US. But once that immigrant becomes acclimated, they drop the bike in turn for the car.³⁰

Europe holds some of the best examples of bicycle infrastructure and acceptance. The Netherlands has the highest participation percentage in Europe. In 2007, average participation in the country saw 40% of its population riding bicycles, but the average dropped a little in the years that followed to roughly 36%. In 2012, 32% of city residence in Amsterdam rode bicycles. But, another city saw higher rates of participation. 50% of Copenhageners commute via bicycle and 35% of all workers in Copenhagen commute by bike. In addition, 63% of Danish parliament commute via bicycle.³¹

A 2014 study of European bicycle users stated the main reasons why they cycle is for convenience and speed. In addition, those bicycle users identifying themselves as cyclists also said they cycle due to the price and for environmental reasons.³²

Investing in bicycle infrastructure is something that the Danes and Dutch see as highly beneficial. In the Netherlands, 39% of trips to the train station were made by bicycle. Most train stations have supervised bicycle storage that average 1,000 bicycle spaces, and in some cases cycle stations can hold up to 10,000 bicycles. But the Danes are taking things to another level. Around Copenhagen, a series of “Cycle Super Highways” are being built connecting the city with outlying suburbs. When complete, 26 “cycle super highways” will have 300 km of dedicated bike paths. 22 municipalities are collaborating on the project. It is said that the project will save \$44 million dollars in public expenditure thanks to improved health.³³

European studies on the environmental impact of bicycles were also positive. A 2011 study found that a car emits 271 g CO₂ per passenger per kilometer traveled. While a bicycle emits 21 g CO₂ per passenger per kilometer traveled. A 2008 study found that a cyclist who commutes via bicycle 8 km to work, 4 days a week, avoids 3220 km of driving per year, 380 liters of gasoline and 759 kg of CO₂ emissions per year.³⁴

In terms of cycle touring, one European study found that cyclists spend an average of \$36 dollars a day whereas the average car visitor spends an average of \$10 a day. The two explanations the study gave for this was that car travelers are able to bring supplies with them whereas cyclists need to buy supplies frequently. And secondly, cyclists are exerting themselves and thus tend to overcompensate by eating more.³⁵



Figure 21: Denmark is making large investments in bicycle infrastructure.



Figure 22: Minneapolis is the #1 Best Bicycling City in the US despite weather conditions.

When Life Hands You Lemons...

Progress is slow to embrace the bicycle in the United States beyond recreational purposes. But that does not mean it should be dismissed completely. Bikes are outselling cars^{37 38}, millions of people use them, and public perception needs to stay positive about them. Despite the many reasons people choose to cycle, there are an even greater number of reasons to invest in bicycling infrastructure.

With tens of millions of people bicycling in the United States, the bicycle has an undeniable influence on many Americans. In some parts of the country it is less prevalent, but in many cities, notably Minneapolis, Portland, Oregon, Boulder, Seattle, and Eugene cyclists are abundant. These cities have many cycling advocates and over time their cycling infrastructure has multiplied. These cities are proof that if you build it, they will come.

Chapter 3: **Bicycle Touring**

Bicycle Touring Styles



Figure 23: There's no feeling quite like the freedom of traveling by bicycle.

There are many types of traveling cyclists and no established rules to travel via bicycle. Although people have been traveling the world via bicycle since it was first invented, in recent years the bicycle has been overshadowed by more rapid and streamlined methods of travel such as the automobile and airplane. Nonetheless, countless cyclists continue to travel the globe via pedal power despite the lack of infrastructure for their preferred travel method.

There is no limit to the level of quality cyclists can buy into. This applies both to gear and the level of comfort on tour. In terms of bicycles, bespoke, finely crafted machines can be tailored to the rider in the most exotic materials available. For the budget conscious, there are many manufacturers with models specifically designed for touring and long distance riding and the number of accessories tailored to bike touring is endless. It is also not uncommon to see cyclists touring on old thrift store finds as well. But the traveler's gear only begins with the bicycle and there are countless other items to consider. Although there are no specific guidelines for how to travel via bicycle, a common theme is to bring all that one needs with him/her. This is commonly known as "self-guided," or "self-supported" touring. A typical traveler may camp and cook along the route, carrying all necessary items to do so.⁴⁰

This stemmed from history when travelers on horseback and bicycle had little option but to camp and cook in their travels. Today there is no shortage of ultra-light gear to choose from, which is common for touring cyclists to carry.



Figure 24: Self-supported touring cyclists carry all his/her gear on the bicycle.



Figure 25: Cycle Tourist traveling through Peru.

Cycle Where the Heart Leads You

Just as there are no rules for what bike you should ride or what you should bring with you, there are no rules as to where you should go or for how long. Often, when we think about touring cyclists, we might think about epic journeys we heard about where someone cycles around the US or through Asia. Although these trips are common, they may not be the norm or a starting point for someone just getting into bike touring.

There are occasions where people are struck by the idea of touring the world and set out to do it without any previous experience. They go to the store, buy all that they need and with a wallet full of cash, pedal into the sunset. There are also stories of people who sell everything they have and the road becomes their new home, traveling to their heart's desire.

Although there is nothing wrong with going on a grand multinational tour, it may not be for everyone. Many people work and get a standard two weeks off per year. This can be limiting for a bike tour, or it may not be. In some ways it depends on your surroundings, starting point, and budget. It is not uncommon for a cyclist to pack up a bike and gear, and fly to the starting point. One such example is the west coast of America which is a very popular destination cycling tourist. People fly from all over the world to cycle the west coast. A common trip plan is to fly into Vancouver, BC or Bellingham, Washington and head south to San Diego, California. Some people can manage this in a few weeks, but people often take longer. But flying to and from your starting and ending points is a way to expedite the adventure to a more desirable destination.

However, if you live in America, chances are there are amazing places to go within a hundred miles of your home. It may more problematic if you live in a dense urban environment such as Los Angeles or New York City, but chances are, on the outskirts of your city there are roads worth riding and scenery worth seeing.

In Washington State, you don't have to go far before you find beauty and peace. Even from downtown Seattle, a short ferry ride will take you to completely different surroundings. Further, the Victoria Clipper, a high-speed passenger ferry that travels between Seattle and Victoria, BC, can take you to another country in a matter of hours.



Figure 26 : The Victoria Clipper can take cyclists from Seattle to the San Juan Islands and Victoria, British Columbia, Canada in a few hours.

The Clipper also makes a stop in the San Juan Islands every morning, so within three hours, you could go from the heart of the city to the heart of an archipelago paradise.

Being near some interesting destinations puts you at a great advantage to bike tour. This makes trips ultra affordable and less planning is necessary. Although some people love to get into the fine details of a trip, others like the simplicity to travel where they want to that day.

But one of the real joys of bike touring is that long trips are not the only way to find excitement and adventure. In fact, it is advisable to start with short trips to understand more about what you are committing too and how your gear may or may not help you.

In recent years, the Sub-24-Hour-Overnight (S24O) trip has become popular. In this type of trip, a cyclist leaves town one evening and returns back the next morning. This is a great option to get away for a night and requires minimal planning and gear.



Figure 27 : Grant Peterson advocates for an S24O (sub 24 hour overnight)

Grant Petersen, founder of Rivendell Bicycle Works, is an advocate for the S24O. In his book *Just Ride*, he writes:

The S24O is a great way to practice touring and get a feel for what you like and don't like in camping gear before committing to a three-week trip with it. Any longer trip, even a day longer, requires a lot more planning. You have to rearrange your schedule or get special time off. If your family isn't into it, you feel guilty leaving them. On a long tour, if something goes wrong or you've pack or planned wrong or the weather turns rotten, you suffer for days. A tour locks you in, and an S24O gives you an escape hatch in the morning. ⁴¹

In 1827, the first railroad was launched in the US and carried passengers and freight. Until the automobile took off around the turn of the century, trains were the most efficient way to cross the country. Trains today are mostly used to carry freight. But the transportation industry relies heavily on tractor trailers for transporting goods around the country as smaller loads can be taken direct, door to door. This has led many railroads to become decommissioned over the years.

Around 1965, some bicycling and walking enthusiasts got the idea to create trails from decommissioned railroads. In 1986, a group of individuals started the Rails-To-Trails Conservancy with the same mission. Since then, the non-profit organization has created 30,000 miles of rail-trails and multi-use trails throughout the United States. They have 160,000 members and 8,000 miles of trails planned and awaiting construction. As trails in the city can see more use, the organization focuses on urban environments. But they do work on trails in rural environments. From their website, they state:

*We've helped craft rural trails that spool out over a hundred miles of open prairie, snake through mountain passes and span canyons and riverbanks, offering views unknown to the highway traveler. We've supported the development of connections between towns and suburbs, linking communities along vibrant corridors. And we've helped create thriving urban networks that are transforming neighborhoods and entire regions.*⁴²

From Iron Giants to Nimble Steel: Rails-to-Trails Conservancy



Figure 28 : The John Wayne Pioneer Trail is the longest rail-trail conversion.

The longest rail-trail conversion in the United States is the John Wayne trail just east of Seattle. The 253 mile trail goes from east of Seattle to the Washington-Idaho border. It heads over Snoqualmie Pass in the Cascade Mountain Range and through a 100 year old tunnel. The trail is primitive in construction and desolate. Miles could be traveled on it without seeing people. It is a combination of ballast, crushed rock and sand. There are four primitive campsites along the trail, but they are within a short span, leaving most of the trail barren. Further, water is scarce along the trail.⁴⁶

Rail-to-Trails shows the innovation and dedication of individuals making a change in their surroundings for the greater good of the community. Part of their vision is to connect communities in America and give everyone access to at least 3 miles of trails. The trails they create in rural areas have potential for bridging gaps metaphorically and physically.



Figure 29: ACA Maps are common to be used and seen while bicycle touring.

Bicycle Routes and Adventure Cycling Association

Do you remember in old western movies how people are just drifting around the country with little more to guide them than the sun and a general direction? Well, in some ways, bike touring is quite similar to this. Some people are just heading south or west for even months at a time and being “lost” isn’t that big of a concern. After all, it’s about the journey and not the destination.

It is not uncommon for a cyclist to have little more than a map to guide them. There are even people who arrive in the country for the first time and use the free tourist maps at the airport to guide their entire tour.

Today, we have more resources than ever before to plan a trip. You can find every campground, motel, bike shop and ice cream shop in the country via the internet. But even in this age of advanced technology, this can’t always help a touring cyclist. For the most part, touring occurs in places where Wi-Fi usually does not broadcast. Items such as satellite phones are beyond most tourist’s budgets. Even batteries on mobile devices die and it may be days before they can be charged.

Thus, physical maps become sacred items on a tour. This can be your lifeline back to civilization, so having one is probably not a bad idea. For some, a basic tourist map from the airport is enough. But for most people, they require a bit more information for peace of mind.

It is important to note, that despite the intricate routes charted by Adventure Cycling, the majority of cycling occurs on the side of highways. This can be both good and bad. If you have a breakdown on your bike, it could be easier to get a ride to the nearest bike shop. But, it may be uncomfortable to have semi-trucks passing by at 60 mph, the slip-stream generated by the truck can knock a cyclist over. Further, debris, rumble-strips and tight shoulders can make for a stressful trip. But for the most part, cyclists are safe to travel this way, and most states allow cyclists to ride on highways. However, most Interstates prohibit cyclists from traveling on their or on certain sections of them.

Adventure Cycling is also the leading organization working to develop the US Bike Route System (USBRS). In a way, this system picks up the intentions from the Good Roads Movement to establish official routes of travel specific to the bicycle. The USBRS will have 50,000 of official signed routes connecting the US. Currently, 40 states are involved in establishing these routes.

In Washington State, USBRS 10 has been established thanks to volunteers like John Pope. Mr. Pope spent years working on this project. This route connects Vancouver Island, BC to the west, passing through the San Juan Islands to Anacortes, through Burlington before continuing through the North Cascades highway and eventually hitting the Idaho border. There are some signs along the way, guiding cyclists on the official and safest path through the area.

USBRS and Alternative Routes

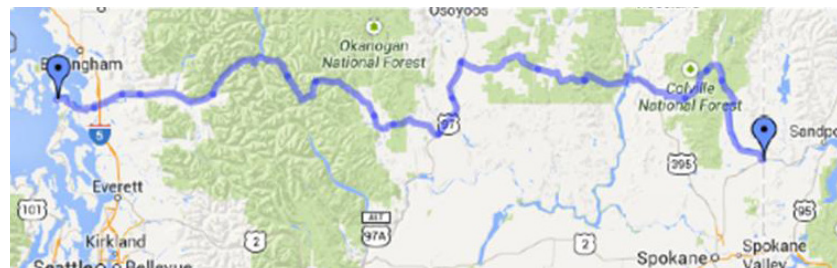

Figure 32 : USBRS10 was designated in Washington State

It should be noted though, that there are off-road routes that have been established in the US. The Great Divide route from Canada to Mexico is one of the most famous routes. Adventure Cycling has created maps for this route. There is an annual race along this route for the extremely endurance mountain biking athletes. The documentary film Ride the Divide depicts the challenge of this route and the struggles cyclists endure to ride it.

Off road touring has spawned of subculture that has become popular in recent years. “Bikepacking” is a cross between ultra-light backpacking and bike touring. Cyclists ride a style of mountain bike specific to this style of touring and carry a minimum amount of gear, making “self-supported” tourist look like they travel via a Cadillac. This style of touring usually assumes an off-road trail and camping in the wilderness, sometimes in official campsites and sometimes off.



The goal of The United States Bicycle Route System is to connect America through a network of numbered interstate bicycle routes.

NATIONAL CORRIDOR PLAN

May 2015



Prioritized Corridors are not routes, but 50-mile wide areas where a route may be developed. These corridors have been assigned route numbers.

Alternate Corridors provide additional consideration for interstate routing. These corridors have not been assigned route numbers but may be prioritized. Corridors may be added or existing corridors shifted as needed.

Established U.S. Bicycle Routes designated by aashto appear as defined lines on the Corridor Map. For specific route information visit www.adventurecycling.org/routes/usbrs.

— PRIORITY CORRIDOR
 — ALTERNATE CORRIDOR
UNITED STATES BICYCLE ROUTE SYSTEM
..... PRIVATE OR PUBLIC FERRY
— UNITED STATES BICYCLE ROUTE

Figure 33 : The US Bicycle Route System as of May 2015

Planning Travel Distance for Cycle Touring

It is about 3 million rotations of the bike's crankset that the average touring cyclist makes on an average day. This, of course, is affected by distance traveled. This variable varies greatly between riders. Some cyclists are in better shape and a 100 mile day is about average. There may also be a time constraint where the traveler has a small window to traverse a long distance, which leads them to put in heavy mileage days.

The opposite can occur for other riders. Some riders only want to ride 20 miles a day and prefer to do more relaxing than riding. In either case, there is no wrong answer.

However, there may be some complications in the amount of daily mileage traveled depending on the distance between accommodations. For example, if the cyclist is camping along the route, some areas of the route may be more barren than others. This might force the cyclist to camp illegally, get a motel room, travel a distance outside their comfort zone, or lastly avoid the area all together.

A more detailed example of this can be seen in Washington State. Generally speaking, along the Puget Sound and ocean, there is a relatively short interval between campgrounds, most of which are state parks. A cyclist may average 30-40 mile days traveling from one campsite to another. But, crossing over the Cascade Mountain Range, the eastern side of Washington State is more rural. In this terrain, a cyclist might have to average 60-80 miles a day between campgrounds.

Terrain, climate and population density all contribute to how popular an area is for touring cyclists. These variables create natural hot spots and dead zones for travelers. This can become problematic in both cases. Like a department store on Black Friday, everyone wants the best deal. It's not much different with campsites. In recent years, popular destinations like Yellowstone National Park have become so popular that there are year long wait lists for campsites.⁶⁹ Like the mall parking lot during Christmas, campers circle the park starting at 6am, waiting for someone to leave so that they may get any campsite in the park.⁷⁰ Otherwise, they have to stay at a "cheap" \$300 a night motel outside the park.

For cycling tourists, popular destinations like the San Juan Islands are not much different than the experience at Yellowstone. Some campers make reservations a year in advance. This leaves little room for spontaneity, and the early planner gets the worm. It also gets expensive if you have to resort to a hotel room to find any place to sleep.

In more desolate areas, the lack of amenities can be hazardous to cyclists. The need for water and occasional refuge from the elements can leave a cyclist feeling miserable and desperate. In this case the cyclist may have very few options and it might mean a few horrible days before they reach civilization again.

Beyond basic necessities, a cyclist is usually keen on the location of the closest bike shop. This isn't always the case, but some believe it brings them peace of mind that should they break down, help is never too far away. A prepared cyclist will have some basic tools, a spare inner tube or two, and other small replacement parts. But many items are too heavy or bulky to carry. A bike chain, for instance, can weigh around 10 ounces. This is a part that will most likely not break, but there is a chance that it can. And if your chain breaks in the middle of nowhere, you're dead in the water. You could carry a chain tool in case this happens, but that is an extra 3 ounces. So, the more barren the area being traveled through, the more precautions may need to be taken.

Chapter 4:

Bicycle Touring Amenities

Home is Where You Pitch Your Tent



Figure 34 : Camping off the road is common in bicycle touring

The “credit card” style of touring is a luxurious option in the spectrum of touring styles. For most, they can’t afford such luxuries or more likely, they feel that this misses the point of bike touring. The experience that many desire is one with nature and their surroundings.

When you travel at 10-20 mph via bicycle, you noticed everything. When you travel via plane, you might look out the window and if it’s not cloudy you could see a part piece of the land below. In a car, you might see some landscape briefly, but the scenery changes quickly. On a bike, you have no choice but to see all the cracks in the road, rivers, bridges, mountains, etc. And if you’re climbing up a mountain, you will have plenty of opportunities to stop and enjoy the view. This becomes one of the main reasons people enjoy touring via bicycle, to see more of the surroundings.

When it comes time to rest for the night, most prefer to sleep under the stars. For some this means in a sleeping bag on a piece of grass, but for many it means in a lightweight 1-2 person tent and then in a sleeping bag, possibility over a sleeping pad and with a small pillow.



Figure 35 : Hike & Bike Camping is sometimes available at state parks.

But where that tent is pitched for the night can be controversial. Traveling along long desolate highways, miles from civilization, many cyclists set up camp just off the road, usually on private property. This can be a potentially rude awakening should the property owner or local law enforcement catch them trespassing. Further, there are no amenities in these conditions, and cyclists large quantities of water to function properly.

Those who wish to avoid these pitfalls stick to the current quasi-infrastructure for camping cyclists, state and national parks. Not all state parks have campgrounds, but many do. Some state parks feature what are known as “hiker-biker” sites specific to those traveling under their own power. Cyclists, hikers and in some cases kayakers, hold priority to these site and they can not be reserved unless that is your means of travel. These types of campsites are often not located with the rest of the campsites, and are instead are sometimes tucked away off a trail in the forest somewhere on the grounds. Further, they have a lower fee than a standard campsite. For the most part, these sites are a blessing for traveling cyclists. But in some cases, it’s better to spring the extra few dollars for a regular site because it might be closer to the beach or it might not be located in the mosquito laden bushes where they put the lesser used “hiker-biker” sites. Some national and county parks have a similar setup for cyclists, but it is best to do some research prior to the trip to ensure minimal issues. Lastly, hiker-biker sites can not be reserved and operate on a first-come, first serve basis.

In many state parks in the country, there is an official-unofficial “no-turn-away” policy toward cyclists. The logic is, where are you going to send a cyclist if the campground is full, there many not be any options for them. So although most do not publically admit it, a state park will find room for traveling cyclist despite the campground being potentially sold to capacity. At some parks, several site are reserved specifically for this purpose, so that a cyclist gets the standard amenities of a regular site. But, be forewarned, these reserved sites are often the least desirable ones on the ground. If all you need is a place to stay, it will work. Is it a picturesque location? Probably not.

Some parks are so popular that they cannot leave sites open, despite this unofficial no-turn-away policy. It’s more economical for them to rent the space to an RV for the night than wait for a potential cyclist to show up. In these cases, they might have an area in open patch of grass somewhere on the grounds that the direct cyclists in such an event. Again, this may not be the most picturesque spot, but you can sleep with peace of mind knowing there is a waterspout close by as well as a restroom.



Figure 36 : Hike & Bike campsites can have minimal amenities

Despite how glamorous a “hiker-biker” campsite may sound, this does not mean that the grounds have showers or even hot water. Not all parks are equal. Some of the more popular destinations might have showers and hot water plumbing, but it’s best to research these things before hand. Often, a touring cyclist will arrive at a new campsite and check the restrooms for shower stalls. There is fair chance that the park does not have showers. In which case, you hope that the next one does.



Anomalies Along the Road: A profile of Whitefish Bike Retreat

In recent years, a few outliers have emerged in the world of bicycle specific hospitality. One prime example of this is Whitefish Bike Retreat in Whitefish, Montana. Located along the Northern Tier route, the Great Divide Route and the Great Parks route, Whitefish Bike Retreat is in a prime location to serve cyclists traveling across the country both in the east-west direction and in the north-south direction.

Figure 37: Whitefish Bike Retreat in Whitefish, Montana

In an interview with Cricket Butler, the Whitefish Bike Retreat founder, she explained her reasoning for building the facility as well her strategy for building a sense of community through the Retreat:

C.B. - I am a cyclist - I raced mountain bikes for almost 8 years and toured much so for me I wanted to create a place that combined everything I have experienced out on my journeys. I wanted to create an affordable place (Lodging and Camping) for cyclists to come and get support with logistics. I wanted to create an atmosphere where people could come together and talk with each other about their journey and experiences. The way I have the Retreat set up does this. You wake in the morning and you could be sitting having coffee with someone touring across the US or a family here giving mountain biking a try for the first time to someone about to head out for a road ride for the day - this is where interests get sparked and friendships are made. My guests make this Retreat!!!!

Cricket Butler opened the bike retreat in 2013 after permanently relocating to the area in 2012. She gave some insight into some of the challenges she faced when building the retreat, she said:

The Retreat was not understood when I was in the building process - but I had the vision and built it the way I would wanted it if I was a guest traveling through and it has been well received by all - it fact it is always a surprise to people not really sure what to expect here. That is exactly what I wanted to see. Local Cycling Clubs use the Retreat for Camps and Clinics and local organizations use the Retreat for annual meetings to employee getaways - we are active with all the local clubs and organizations and help maintain our local trail systems. No one really understood what I was trying to create here - but now they get it and see the potential and fully support what we offer here.



Figure 38: Guests visit the retreat for the areas many bicycle trails



The retreat caters to cyclists of all varieties, accommodating touring cyclists as well as those coming to Whitefish for epic mountain biking and other activities. The accommodations include tent sites as well as the “bunk lodge.” The facility has the capacity to host 17 guests in the lodge and 32 campers via tent sites. The 4,000 square foot lodge is billed as the heart of the retreat and offers rooms of varying sizes. Additionally, there is a shared kitchen space, showering facilities, laundry facilities, common area with TV and wifi, secure bike storage, bike service shop and tools, and fire pit. During the busy summer season fresh coffee and baked goods are offered to guests. In peak season, a private room costs just under \$100 per night and a bed in a shared room costs \$40 a night. The facility has up to 5 staff working to maintain the facility. Cricket further explained some of the Retreats amenities:

The Whitefish Bike Retreat offers many cycling friendly amenities such as Bike Wash Stations, Free Lube, a work bench with tools and pumps and rags, shipping bikes and gear for guests, secure bike storage, shuttles to destinations, parking, staff to provide specific information about routes and trails in our area, a small camp store providing snacks and emergency bike parts and gear specific to touring

Figure 39: Whitefish Bike Treat has many amenities for cyclists and guests.

Although Cricket initially thought her target market was touring cyclists due to the proximity of 3 Adventure Cycling routes nearby, it turns out that most people come for the mountain biking in the area. In addition, Cricket explained that many cyclists use the Retreat as a basecamp, traveling within a radius of 200 miles and using the Retreat as a starting and ending to their trip. The Retreat offers free shuttles within the area to arrange pick-ups and drop-offs for guests on trails or to and from Whitefish, which is 8 miles away.

When asked about the economics of the Retreat, Cricket simply stated that the model is profitable and she is able to support herself and her family through the business. She made a significant investment into the Retreat and it has worked in her favor. Further, she explained that she gets about 500 cyclists staying with her throughout the year and each stay is longer than 1 night.

In addition, Cricket said she is part of a group of individuals in Montana called the Bicycle Tourism Partnership Committee who are working to provide shelters along routes in Montana specifically for cyclists. Similar to the hiker-biker campsites in Washington State, the proposal in Montana calls for camping facilities, showers and secure bike storage for traveling cyclists.



Figure 40: The treat offers shuttles to town and local trailheads.

Outlier of the Outback: A Profile of Bike Barn Camping



Figure 41: Keith, Anita, and Taylor arrived at camp via Whitefish, Montana.

Along Washington State’s highway 20, which is the west most section of the Northern Tier Route across the US, exists another anomaly of bicycle travel hospitality. A place simply known as Barn Bicycle Camping is right on the highway between Mazama and Winthrop. A small sandwich sign on the road advertises bike camping in the driveway. Besides a basic sign and a Facebook page, not many people know this place exists.⁴⁷

Jim Gregg opened the facility in 2008 and advertised a “Barn Bicycle Camping” experiment on a basic Blogger page, stating “an experiment to support and promote bicycle travel we offer camping for traveling cyclists.” He built a small barn on the side of his property for the project. Cyclists are asked to pitch their tent next to the barn, and the barn serves as a place to hang out if the weather is bad. Other features he added were an outdoor solar shower and composting toilet. A small placard on the barn gives instructions to cyclists as they arrive. These include the wifi password, location of cold beverages within a fridge in the barn and how to turn off the irrigation system. The project works on donations of \$10 a night.

Jim makes an effort to say hi to all those who stay by the barn. He asks them about their travels and takes a photo of them to post on his Facebook page. The page serves as a chronological record of the hundred of people who stay there each year, mostly in the busy summer season.

In an interview with Jim, he explained the project and his motives. He started the project to serve the cycling community, those who specifically traveled under their own power and not by vehicle. It started as a hobby for him and it is setup to require a minimal amount of effort to maintain. Jim says he only spends about 30 minutes a week cleaning the composting toilet and solar shower. He explained that the largest investments were the toilet, shower, wifi extender, and picnic tables and his total investment was about \$1500. Between 50-70 cyclists stay with him between the months of June and September. The number has been lower was recent years because the area has experienced wildfires. Jim explained that 99% of his visitors love the place and praise it and the neighbors haven't complained.



Figure 42: Nora and Joe settled in for the night en route to Yellowstone National Park.



William W. White (1948-2012) & Twin Bridges Bike Camp

Bill White chose to retire in Twin Bridges, Montana. He would hang out in The Weaver's Studio and watch cyclists in funny clothes through the window. As it turned out, Twin Bridges is at the intersection of two cross-country cycle touring routes: The TransAmerica Trail and the Lewis & Clark Bicycle Trail, both of which are mapped by Adventure Cycling Association. As cyclists would come into the studio for coffee he began hearing their stories and became intrigued. He was quoted several times for saying, "All the bike riders passing through were like gold going by in a river," he says. "I started thinking about how to make Twin Bridges more than a place to get a cup of coffee."⁴⁷

Figure 43: Bike Camp in Twin Bridges, Montana

Bill spoke to the mayor and began raising money for his vision. He would ask cyclists what they needed and took notes. He raised \$9000 dollars to build a structure specifically for touring cyclists. The structure was built in the town's Jessen Park. It was basic: a screened shelter with a few picnic tables, a sink, shower, grill and a patch of grass to pitch a tent. The shelter would simply be called "Bike Camp." Although it is described as the first of its kind, in terms of a publically owned bike touring camp, it is. But Jim Gregg's Barn Bike Camping project was launched the year prior, making it the first free shelter specifically for traveling cyclists. But Bill's concept was key: keep cyclists in Twin Bridges longer and they will spend more money. And as the saying goes, if you build it, they will come.
48

Within the first summer, 300 cyclists stayed in the Twin Bridges Bike Camp, and the numbers grew in the following years. Local businesses reported increased sales. Despite the shelter being free for use, most cyclists left donations. Within its first year, the donations alone totaled \$6000. The guest log was filled with praise and soon word spread among cyclists about the bike touring treasure in Twin Bridges. Cyclists itineraries began to include special trips to the town to experience the shelter first hand.



Figure 44: The Bike Camp works on donations.



Prior to completion, locals were skeptical about the strange cyclists staying in their town's park. They feared vandalism and other petty crime. But crime never came. Instead, kindness and generosity prospered. Cyclists even made requests for cleaning supplies, which came, then a clothesline, and a bike repair stand. Soon the local community felt how the lone shelter was able to transform their town into something more than a place to stop for coffee.

In 2012, Bill White passed away peacefully. He was diagnosed with melanoma the previous year. Searching the internet for Bill White Bike Camp brings up many sites dedicated to his memory. Countless comments praise the shelter and what Bill White did for the cycling community. His kindness and legacy will live on for many years.

Recently, the Twin Bridges Bike Camp was renamed the Bill White Bike Camp in his honor. Although their original website no longer operates, as of 2015, the shelter is still operational, serving hundreds of cyclists every summer.⁴⁸

Figure 45: Bill White was thinking progressively about bicycle tourism in Twin Bridges, Montana.

Guided Tours



Figure 51 : Group Tours are popular options for cyclists seeking a catered vacation.

There are many individuals who travel via a self supported tour. However, there are many individuals who prefer to travel in an organized group. Similar to the logic of a cruise ship tour, where individuals want an all-inclusive vacation and all of the logistics and planning are included, group tours offer cyclists a turn-key solution for cyclists. There are many group tours, or guided tours, offered throughout the world. Chances are if you have a desire to ride in a beautiful part of the world, there is most likely a company who will take you there.

Typically, the way a guided tour works is after you pick a tour to join, you arrive with your bicycle and gear at the departure location and a guide will accompany you to the destination. Often the guide is in a shuttle van where the luggage is stored and cyclists can ride should they become tired of riding. But like the many styles of touring, guided tours can have several levels of amenities. Some guided tours are still self-supported, where the guide will ride with you, but you are still carrying all your own gear. Some tours are much more streamlined like the “Inn-to-Inn” model, where cyclists are guided from one hotel, or inn to the next, and a support vehicle delivers luggage each evening. Meals in this model are at cafes and restaurants. Often, these tours have a maximum capacity of about a dozen cyclists.

Searching the internet for guided tours will supply the cyclist with endless possibilities for trips with varying levels of comfort. Adventure Cycling Association offers guided tours in most parts of the US in varying degrees of support. And similar to the amenities offered in guided tours, some companies also offer social components to their tours. ACA offers tours for families, women only, young adults, mountain bike only, and epic tours.⁶⁰

One example tour that ACA offers is a van-supported tour of the Northern Tier Route. This route travels from Bar Harbor, Maine to Anacortes, Washington. It is over 4,000 miles and the tour is planned to take 87 days to complete. The daily average riding miles is about 56 miles and the tour is billed as being

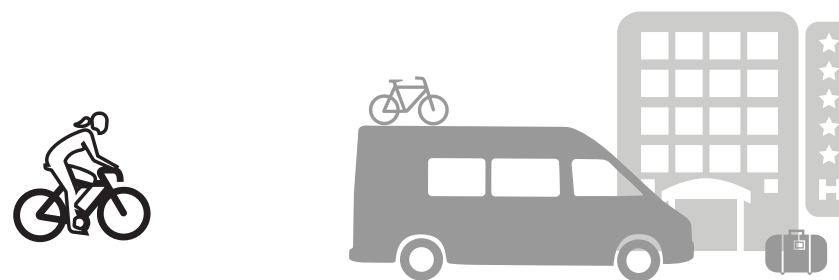

Figure 52 : Group Tours offer shuttle assistance and hotel amenities.

advanced in terms of physical demand. The tour accommodations are both camping and indoor lodging. Meals are described as shared cooking. A van accompanies the cyclists to carry luggage and gear.⁶¹

To summarize, guided tours are a viable choice for many wanted to experience cycle touring. They offer a social component, services, and planned logistics. This gives the cyclist peace of mind that they can focus on riding and scenery rather than logistics. It's a great way for cyclists to emerge themselves in the experience without feeling like they are alone and defenseless riding solo in remote areas.

The Rise of the Internet: The Importance of Being Online

There are resources for traveling cyclists, if you dig deep into the internet. Just as Whitefish Bike Retreat and Bike Barn Camping have a web presence, others do as well. Without the internet to help cyclists, they would not necessarily know these places exist. If, by chance, the cyclist is equipped with an Adventure Cycling route map, which often lists such specific bicycle accommodations, a cyclist might find a bike touring treasure such as this. But not everyone who is offering bicycle hospitality is in plain view. If the sandwich board wasn't on the side of highway 20 outside Bike Barn Camping, cyclists might just pass right by.

If you think about the international draw of bicycle touring, it is best to think that the reach of your audience in terms of the internet. We have more access to information than ever before, and our world is also more linked than ever recorded. A foreign tourist relies on the internet to find route information, accommodations, and anything else they might need. From the perspective of hospitality, the internet becomes the link between the host and someone in front of their computer around the world. In terms of the rarity of bicycle specific hospitality, the host should have a strong internet presence in order to inform the world that their facility exists. But the internet could also be a source of information for basic services like showers, which rarely get posted online.



Figure 46: Warm Showers allows cyclists to host other cyclists while traveling

Hospitality 2.0

Quite similar to the Warm Showers peer-to-peer model, another company has changed the way we think about hospitality. Airbnb started in 2008, and in only 8 years, has exploded in popularity. The company is now valued at \$20 billion and has 1.5 million listings in 34,000 cities in 190 countries.

Airbnb generates revenue by charging booking fees when a vacation is booked. The fee varies from 6-12% depending on the listing. Additionally, the company makes an additional 3% on all credit card transactions. What is unique to this company in relation to a traditional hospitality model is that they own none of their listings. The company focuses on increasing its users and matching them with listings. The listings themselves range in quality and size. Some people list a spare bedroom that they have renovated specifically for this purpose while others rent out their second home. The rise in popularity of Airbnb has led some people to build a secondary structure on their property strictly for the purpose of renting it on the site.

Airbnb did not invent the peer to peer hospitality model, but it made a successful case for it. There are dozens of other sites which are similar such as FlipKey, HomeAway, VBRO, and RoomORama. Airbnb has acquired some of its competitors over the years. But competition in this market is thick and proves people are perfectly willing to stay with a stranger while on vacation.

One service that created a niche market is HipCamp. As the name implies, this service helps users find a cool place to camp. HipCamp appears to be becoming the “Airbnb of campsites.” Private landowners can rent a small piece of land to campers for a short stay. This private listing can be a tent site or a small cabin. What is unique about this service is that it aggregates information about public campsites. It appears that HipCamp has positioned itself to be able to book these public sites in the future. But for the time being, the service takes you to the corresponding site where users can book the public site or find more information about it. HipCamp users can then review and connect through the service, leaving reviews and bookmark listings. Property listers are charged a variable rate based on several factors in addition to a 3% transaction fee. The service also offers insurance to listers and a \$100 referral program. Very few requirements are placed on a listing, but the users must have access to a toilet. However, there is no mention of users getting access to water. The service has a “leave no trace” policy requiring users to pack out all garbage. Further, the service has a one-strike policy against users and bans them

from the service after their first offense. The service also helps listers by offering professional photography of the property.

One thing to note about Hip Camp is that it is relatively new, and listings are limited. A quick search around Seattle showed every public campsite within 40 miles. However, even when told to search as far away as 150 miles, only those within the 40 mile radius appeared. In addition, around Seattle there were no private land campsites listed, only public sites. And of the public sites could only be booked via their respective websites.⁵⁷

Airbnb has started a new trend for people to rent out their property, leading to a variety of new services claiming to be “the Airbnb of fill-in-the-blank.” The hospitality company has led to many people trying to profit on things they don’t use frequently. And it was only a matter of time before people started renting out their bikes.

In the past decade, bike sharing programs have sprouted in major cities around the world. A company called Motivate is responsible for several bike share programs in North America. This company operates the programs for the parent company or city. These programs are usually sponsored by a large corporation but owned by the hosting city.

Seattle launched a bike share program through Motivate in October of 2014. It started with 500 bicycles and 50 bike stations. A nonprofit was started to operate the program because the city did not want to own it initially. However, the program may need to shut down if the city does not financially rescue it. Ridership has been low, with a reported rental of less than 1 ride per bicycle per day. This has led the parent company to become insolvent.

One company, claiming to be the “Airbnb of bikes,” is challenging public bike sharing programs with their service. Donkey Republic launched a service called AirDonkey, which privatizes bike sharing and gives riders a choice between large public bike share programs and their boutique offering. What makes Donkey unique is that any bike could be used in the program. An example of how it works is that a local bike shop could have a fleet of rentals that it lists on AirDonkey.

Bike Share

Donkey Republic then sends them a special bluetooth enabled lock for each bike. A smartphone app then records the location of the bike and lists it for rent. When an app user is in the area, they can pay AirDonkey’s fixed daily rate, reserve the bike, and locate it wherever it is parked. When they approach the bike, the bluetooth lock opens and they user rides away. One issue with this service is that the user assumes all responsibility for the bike. Should they get into an accident or the bike get stolen, AirDonkey automatically charges the user a fee and compensates the original bike owner. Another issue with the service is that it is currently not in the US, and only in a few countries. The Copenhagen based company says they have interest from several cities in the US but is awaiting bringing the service to America.

In a similar entrepreneurial fashion, other companies are looking for a niche way to rent bicycles. One company in particular is seems like a true “Airbnb of bikes, surfboards, and snowboards.” SpinLister is featured in several large cities around the world and has users in 100 countries, but states that only 60% of these may be active at any time. Unlike AirDonkey, the SpinListers service operates almost the same as Airbnb. A user searches a particular city city for listings, a variety of different bikes can be found from unicycles to touring bicycles. The user contacts a lister to arrange a rental, the lister approves it and arranges pick up. SpinLister then takes 17.5% of the transaction.

Chapter 5:

Profiles of Touring Cyclists

A Modern Touring Family: A Profile of the Eells Family.



Figure 47 : The Eells family at top of Logan Pass.

Michael Eells and his wife Rachel define the modern American family and exemplify how summer family vacations could be spent. Michael and Rachel are both school teachers who live in Seattle and like most teachers, they have the summer off from teaching. But instead of taking a road trip to Disneyland over the summer, the Eells family hit the road on bicycles and bring a tent for accommodations.

Ever since he could walk, Michael Eells soon took to hiking, camping, and enjoying the outdoors. He began bicycling in Washington State when he was 5. After Michael and Rachel had their first child, they began bike touring as a family. And when they had their second child, they continued to cycle tour. Their children, Oliver and Abbey are now 9 and 6, respectively, and enjoy their family cycling touring vacations every summer. In an interview with Michael, several questions were asked regarding his experiences and passion of bicycle touring as well as insights into his family's touring dynamics and the logistics of touring as a family.

What does bike touring mean to you? And why do you do it?

M.E : For me, bike touring is a way to leave everyday concerns behind for a while, experience a sense of adventure, and a way to access beautiful and interesting places with a more comprehensive and intimate perspective than can be achieved otherwise. For my family, it is a way to spend some tech-free time together, access nature, and all share in a sense of accomplishment. We do it because we like to go places and see new places but we all hate spending time in cars. We like traveling without polluting, without feeling like we are harming the places we are visiting. And we've found the pace of bike touring to be ideal—fast enough to see very different places every day but slow enough to not miss anything. I've taken long road trips in the past and found that driving to a national park and stepping out of a car to look at some amazing scenery just doesn't feel real. I've always appreciated things more when there is some effort or accomplishment involved, and bicycling provides this.

How long have you been touring?

Our first tour was in 2007, when Oliver (our oldest) was 1. Neither Rachel nor I did any touring before we had kids. We have managed to squeeze in at least one bike tour into every summer since then, except for the year Abbey (our youngest, now 6) was born.



Figure 48 : Rachel and Oliver Eells enjoying a scenic ride.

When you plan a trip, what are your top priorities when planning? In other words, what are your main concerns and objectives?

I start with a destination or route in mind—typically those that are mapped by Adventure Cycling. Our first tour was in the San Juan Islands, and this route was based on the experience of a friend, but since then I've started with Adventure Cycling routes. From there, elevation gain/climbs have ruled out many routes, and also distance between campsites or food services. When our kids were very young we needed to have frequent stops and short mileage days, which rules out many routes. We also needed towns with parks and play equipment (this was actually critical when they were still riding in the bike trailer). These requirements limited our options, but we did find some good options. When I was still pulling a Burley kid trailer, we stuck to coastal routes without major climbs (the San Juans, the Pacific Coast). The kids love the beaches, and the Oregon Coast, for example, has frequent services so this was a great route for families like ours. More recently, now that we have both kids on tandems and they are a bit older, they are happier with longer stretches on the bike and climbing is easier so we are more concerned with nice campgrounds/destinations. This past summer's route to Montana was based more on a desire for quiet roads, scenery, and swimming and hiking opportunities. As we travelled across Eastern Washington in a heat wave, swimming became a top priority so we adjusted accordingly.

As a person who has a family and tours with young children, how has this changed how you tour? Do you feel any limitations when touring with a family? What additional precautions do you take to tour with your family?

Rachel and I are somewhat unique in that we did not bike tour before we had kids. I've known some people who did tour before they had kids, and found the transition frustrating and haven't done it much as a result. Maybe we just didn't know any better? At any rate,

we started bike touring because Oliver was a very large baby/toddler and difficult to carry — which made hiking/backpacking difficult to impossible. But pulling him in a trailer was much easier. We dislike car camping and car travel (for reasons described above), so we decided to try strapping the camping gear on our bikes and found that it worked very well. I've described many of our limitations above (climbs, frequent stops, etc.) but I could add that there does seem to often be a tradeoff between flat and direct routes vs. low traffic routes. When our miles are limited, it can mean riding on a less pleasant, higher traffic route instead of a longer, hillier, more scenic route. Rachel and I have been daily cyclists for years in a busy city so we are relatively comfortable in traffic, but I'm sure this would be an issue for many. I should mention, however, that we have found that drivers are more cautious and courteous when we have the kids with us (I definitely notice this difference as compared to when I bike alone). But generally, compared to touring without kids (I have done a few short tours without kids since we started), the main difference is in the distance between stops (and, of course, bicycling is easier when your aren't pulling kids).

Can you give some insight into how many miles you and your family travel in a given day while touring?

Initially, our mileage was 25-30 miles, with stops at least every 10 miles or so when the kids were young and need more time outside the trailer to run around. More recently, our daily mileage is around 50 miles—with some variability depending on elevation gain and weather. Our distance between stops varies quite a bit, but is rarely more than 20 miles in good conditions.

What resources do you use to plan your trips?

Adventure Cycling maps, the books "Bicycling the Pacific Coast" and "Cycling Sojourner," and I've occasionally read trip journals on the website Crazyguyonabike.com



Figure 49 : Michael Eells stopping to enjoy the view.

What is the weakest link in terms of resources for bike tourists?

General travel information provides very little for bike tourists. The above resources are great if you stay on route, but if you go off route you are lost. State highway maps (or even the state bicycle map) provide little relevant information about bicycling conditions. Bicycle camping, or the presence of hiker-biker campsites, is treated like top secret information and often only known based on word of mouth (which is ridiculous). Bicycle touring is a novelty to most people so information can be hard to come by. This can occasionally be a good thing, such as when someone offers to let you camp on their property or offers water on a desolate stretch—something that would be unlikely if bike touring was more common. But it can make planning difficult and may discourage those who like to have plans set ahead of time and don't want to deal with uncertainty and conflicting information. Aside from this, I guess there is the more obvious weak link based on infrastructure—roads and highways with inconsistent shoulders, bike trails that don't connect, etc.

What is something you would like to change or introduce into bike touring?

I'd love to convince more people to do this, but there are probably broader social and cultural issues that prevent it for many people (limited vacation time, limited fitness or perception of fitness, marketing messages about what vacation time should be like, etc.). But even with these limitations, it does seem to me that the messaging around bike-touring could be a little less about the extreme, biking coast-to-coast, once in a lifetime bucket-list activity and more about something that regular people can do in a shorter trip with limited time. There are plenty of excellent one or two week trips that are (or should be) possible. Some things that would make them more possible would be better non-bike access to good touring locations (via train or bus with the ability to carry bikes and luggage), and some improvements I've listed below the next question. Another thing that I'd like to change around bike touring (and other outdoor activities) is the perception that a large amount of expensive, specific equipment is necessary. Many kinds of bikes can tour, and we started without anything bike-touring specific (we used two old hybrid bikes, a used Burley child-trailer, and our existing camping/backpacking gear).

What infrastructure would you like to see to improve bike touring?

I'd like to see more signage alerting others and acknowledging the presence of bike travelers, more cycling rest stops, and clean and quiet hiker-biker campsites. These things all exist in some places, but not many. For example, the Oregon coast features frequent road signs announcing the Oregon Coast bike route, button-activated flashing lights for cyclists in tunnels, etc. Oregon state parks also include excellent hiker-biker campsites, usually set apart from the car campground. In Washington, all acknowledgment of a bicycle route disappears. Many Washington State parks have hiker-biker campsites (and some of them are very nice), but some of them allow car campers to use them so they fill up. The same is true in California. This adds a lot of uncertainty. It's probably not an accident that bicycle touring is most popular along the Oregon Coast. These amenities lead to more touring cyclists, and when we see each other (and cars see us and are reminded of our presence), the experience is more comfortable. One place in Washington that does well with bike touring is the San Juan islands. They include frequent rest stops/pullouts for cyclists on hill climbs, probably because there are a lot of cyclists and they don't want them bunching up on the roadway, but regardless of the reason it does seem like this minor amenity validates the presence of cyclists, adds a little dignity to the challenging sections, and leads to more cycling.

One more infrastructure improvement that I could add concerns traveling with bikes as luggage. Amtrak is very close to being set up to do this well, but does still require that you partially disassemble and box your bike—which is a hassle. Doable, and much better than the complete disassembly required by airlines, but still not ideal.

Where are your favorite places to tour in the US? And where specifically in Washington State?

I've enjoyed each of the places I've toured for different reasons. The place we've returned to most frequently in Washington is the San Juan islands. This is an ideal location because the number of cars are limited, cycling is common, and there are good hiker-biker campgrounds on each island. And, of course, the scenery is amazing. The Olympic peninsula, especially the remote stretches that spur off of 101, are beautiful. Outside of Washington, we've

enjoyed the Oregon coast and some sections of the California coast. This past summer we discovered many beautiful, quiet roads through Northeast Washington, Northern Idaho, and Montana. Glacier National Park was excellent for bicycling.

Can you share a great moment or memory from your bike touring experience?

Our highlight this past summer was riding up the Going-to-the-sun Road in Glacier National Park up to the Continental Divide. We started at dawn, and the alpine scenery changed as the sun rose and around every corner. Along with this was our sense of accomplishment for climbing a mountain pass that we weren't sure we could climb when we started our trip.

Additionally, do you strictly camp while touring? And if there was a shelter for cyclists along the route, would you use it? What would make that situation ideal for you? In other words, would a basic shelter suffice or do you prefer a tent? What amenities do you think would be worth having available specifically for traveling cyclists?

We do camp, almost exclusively (this past summer we spent one night in a motel, but the rest of the 5 week trip we were camping). We would definitely make use of shelters. In the heat, shade would be helpful. This was occasionally scarce in E. Wash. this past summer. Shelters would also potentially open bike camping to a longer season on the west side of the state. We've made use of picnic shelters at parks in the past to sit out passing rain showers/thunderstorms (and we've even camped under them when allowed to). The location of these is usually not ideal—cyclists need rest areas most during climbs, when the going is slow and it's difficult to make the miles to the next mini mart or whatever. As far as amenities, shade/shelter, seating (a comfortable place to sit is a serious luxury after several days touring), and, ideally, cold water and a toilet. Higher level amenities (nice but less critical) might include electrical outlets (to charge phones), a cooking table or platform, some sort of bike stand or rack suitable for loaded touring bikes, and possibly some tools (a floor pump with pressure gauge is another scarce amenity for touring cyclists), but maybe I'm getting carried away?

Richard Garland: A Profile of a Solo Cycling Tourist.



Figure 50 : Richard Garland cycling by Big Sur, California.

Mr Garland represents a common demographic of touring cyclists. He is a retired US Foreign Service Officer and 66 years young. He has done a few larger trips, such as the Way of St. James in Spain and the Pacific Coast Route. Rick prefers shorter trips closer to home. He takes 3-4 shorter trips each summer and likes to do a longer trip once a year. The primary service Rick looks for when he is planning a trip is showers. He likes to stay at state parks because they usually have showers and are an affordable accommodation. I had an opportunity to interview Rick about bicycle touring and its potential infrastructure.

What is bicycle touring to you and why do you do it?

R.G. - It is like feeling unencumbered freedom. Why do it? I gladly embrace being outside in our amazing world, taking fairly big chunks of it in at an absorb-able rate with an exhilarating and challenging feeling of self-propulsion at a minimum cost.

How often do you bike tour and do you have any trips planned in the future?

How often? Only about 2 two to five day a year and 1 longer tour lasting up to 6 weeks. This year finish a Pacific Coast Highway tour that started out my back door in Bremerton, WA and ended in San Luis Obispo, so am hoping to go SLO to the U.S.-Mexico border. Also, a wandering tour around Washington State this summer staying at State Parks mostly while trying to ride through the San Juans, Iron Horse Trail over the Cascades, Grand Coulee, Spokane/Cheney, Palouse, Tri-cities, and maybe back along the Columbia River to Vancouver/Portland and Amtrak back to Seattle.

What would help you bike tour more and what infrastructure improvements would you like to see with regards to bike touring?

Help for bike touring? A Washington State law, as California has, which **REQUIRES** vehicles to give bicycles at least 3 feet of space no matter if they are in a bike lane, on the shoulder or in the lane. **AND**, like in Oregon, the requirement that at least a fixed percentage of the state's transportation budget be dedicated entirely to infrastructure for bicycling.

- Infrastructure? For starters, a plethora of "Share the Road" signs with maximum fine for violation on the signs. Robustly funded state parks (all with showers) with biker campsites that have water, electric power and **NOT** half a mile from the shower. **AMPLE** paved shoulders, using eminent domain authority to make them if necessary. And if I dream, how about solid barriers between bike lanes and auto/truck lanes on the busier roads and highways.

What is an issue you see facing bicycle tourists?

Lack of sufficient shower equipped, affordable (like Oregon) biker campsites along popular routes that are spaced from 40 to 50 miles from each other.

Where do you typically stay when you are touring?

State parks.

Would you stay in shelters made specifically for touring cyclists if they existed? And what value would you place on such an experience?

Stay in shelters? Yes if they had water and showers (and electric power would be very nice) and space for my tent and bike. Value on a shelter? \$15.00/night

Chapter 6:

The Human Cyclist

Cycling Distance and the Average User



Figure 53: A healthy cyclist is a happy cyclist.

Anyone can bike tour. There is no set demographic of user. People of all ages tour from 18 to 80. Men and women as well as families with children tour through Washington State. Some users tour on \$100 thrift store finds and some ride on carbon fiber race bikes. Either way, the average speed for a touring cyclist is much lower than a recreational racer who can average 25 mph.⁶² According to Copenhagen Bicycle Statistics, average cyclist speed is 15.5 km/h or 9.6 mph.⁶³ It would be safe to assume that the average touring cyclist is going at about this speed due to the weight of the bicycle and gear, pit stops for food and water, stops for photography, and the unfortunate bicycle breakdowns.

If you assume the average touring cyclist is moving along at 9.6 mph, then you can assume the average distance travel per day. For some this is personal preference, meaning they only wish to ride for 5-6 hours per day and be off the bike most of the day, others ride for 10 hours a day, depending on the person. But lets assume the average is closer to 6 hours of riding per day.

An average cyclist going 9.6 mph for 6 hours a day would travel 57.6 miles. To cycle between node towns in Washington, an average distance of 110 miles, going at 9.6 miles, the cyclist would be peddling for 11.5 hours. Or, if their average speed was a bit higher, say 15 mph, they would need 7.3 hours in the saddle. But for some people, doing 110 miles and 11 hours on the ride everyday for a month or two is not feasible. You are in the top 1% of touring cyclists if you can maintain this pace. The average cyclist is more likely to do 9.6 mph overall when averaged for 6 hours a day.

DISTANCE v. TIME

<i>MILES</i> @ 9.6 mph	<i>Km</i> @ 15.5 km/h	<i>HOURS</i>
9.6	15.5	1
15.5	25	1.6
19.2	30.9	2
28.8	46.4	3
62.1	100	6.5
124.3	200	12.9

Figure 54: Distance vs. Time of bicycle travel.

Cycling Distance and Water Consumption

WATER v. TIME





 CUPS (of Water)	 BOTTLES (24oz.)	 HOURS (Cycling)
11	3.7	0
13	4.3	1
15	5	2
17	5.7	3
19	6.3	4
21	7	5
23	7.7	6

Figure 55: Distance vs. Time of bicycle travel.

It seems odd to write about the necessity to drink water, but when considering cycling long distances water is vital. Of course the amount of water a person needs while cycling can vary, there are some averages to keep in mind. Age, sex, climate, and sweating all play a role in water intake. The Institute of Medicine made a recommendation of total water consumption, including water from foods of 2.7 liters for women and 3.7 for men. They added that 20% of total water intake is derived from food. That makes about 9.1 cups of adequate intake for woman and 12.5 for men, with an average of 11 cups of water between them.⁶⁴

In terms of exercise and water, a general average of 2-4 of water is necessary per hour of general exercise. This should be increased in times of excessive sweating. And could lead to the need for constant intake given heat, humidity, high altitude and other factors.⁶⁵ As a basic rule, at least 2 cups of water intake per hour of cycling at a slow speed of 9.6 mph. Given a basic example, the average cyclist riding for 3 hours in a mild climate would need a base adequate intake of 11 cups of water plus 2 for each hour of riding, resulting in a daily total of 17 cups of water. And 6 hours of riding would require 23 cups.

Cycling Distance and Water Consumption



TIME v. CALORIES

HOURS	CALORIES BURNED	
	@ 10-12 mph	@ 14-16 mph
1	483	805
2	966	1610
3	1449	2415
4	1932	3221
5	2415	4026
6	2898	4831

Figure 56: Time spent cycling vs Calories burned.

The average US male weighs 191 lbs and the average weight of a US female is 164 lbs.⁶⁷ This makes the average between them 177.5 lbs. If this person were cycling at 9.6 mph they would burn about 483 calories per hour.⁶⁸ If they were cycling for six hours, they would burn about 2898 calories. The USDA recommends a daily calorie intake for active males of 3000 calories and 2400 calories for females. Due to the physical nature of bicycling for six hours a day, the cyclist needs to almost double daily calorie intake to be a healthy traveler. Hence, the touring cyclist is always hungry and looking for food.⁶⁶

The distance between nodes is important for a touring cyclist because those nodes are useful to refuel those much-needed calories. If a cyclist needs to eat between 2500-6000 calories per day, they either need to carry tens of pounds worth food every day, everywhere the ride. Or, they need to stop every day or two to refuel. Given this need, it would be worth noting that a good route node should include healthy food shopping such as a co-op, produce stand, or a selection of grocery stores. Often, cyclists have a tight per day budget and making meals is preferred rather than buying them. Finding a decent grocery store is a fine luxury resulting in fine camp-side dining.



 HOURS (of Cycling)	 WATER (Cups)	 CALORIES (Per Day)
0	11	2700
1	13	3183
2	15	3667
3	17	4150
4	19	4633
5	21	5116
6	23	5599

Figure 57: Number of hours cycled vs water and calorie intake needed.

The Daily Resources needed for Long Distance Cycling.

To summarize, the average adult in the US weighs 177.5 lbs. The average adult needs 11 cups of water per day and 2700 calories if they are active. That adult needs 483 calories per hour of cycling at a speed of about 10 mph and 2 cups of water in that time. Given a distance of about 60-70 miles to travel in a day, the cyclist is faced with a challenge. If they pedal faster, exert more energy, sweat more, they might get to their destination faster, but they will require more water and calories than if they went the same distance but slower. So, pacing yourself is best, and stopping often to refuel will ensure safe and healthy travels.

Chapter 7:

The Economics of Bicycle Travel

Bicycle is in the Billions.



\$133B

In its entirety, the recreational cycling industry contributes \$133 billion annually to the US economy. There are roughly 1.1 million jobs in the US relating to bicycle recreation and camping holds the highest number of recreational jobs at 2.3 million. Americans annually spend 88 times more on bicycle recreation than the total box office sales of the hit movie Titanic. Bicycling is among the top five outdoor activities in the US, and ranges in the top five depending on the age group in question. 23% of the US population say they participate in recreational cycling each year.⁵⁰

Figure 59 : The US Bicycle Industry is worth \$133 billion annually.

Washington State has the highest grossing recreational bicycling economy totaling \$3.1 billion annually. An annual average of \$21.6 billion is spent on all recreational expenditures and equipment within the state. \$20.5 billion of that total generates state economic contributions. This includes all expenditures on state and federal land as well as expenditures related to these trips. After walking, jogging and wildlife photography, bicycle riding is the fourth most popular recreational activity in the state. But in terms of recreational expenditures, bicycle riding is the third highest after wildlife photography and motorized boating. Of the \$21.6 billion in recreational expenditures, \$12.5 are direct contributions to in-state sales. This spending is further broken down into subcategories with the top five grossing categories being food, retail sporting goods, wholesale trade, amusement and recreation industries, and lastly lodging. From this revenue stream, the total tax contributions are about \$2 billion. Further, the recreational industry in Washington State supports approximately 200,000 jobs.⁵²

Relating specifically to bicycles, Oregon State did further analysis of the impact bicycle recreation on their state economy. The 2012 report had many interesting findings showing how viable cycling is to their economy. It should be stated that Oregon's GDP was ranked 25th compared to Washington's 14th ranked GDP and Washington's GSP was almost twice that of Oregon's. However, Oregon has data relating closely to bicycle related expenditures, so it is worth investigating the neighboring state's data.⁵²



Figure 60 : The bicycle industry in Washington State is worth \$3 billion annually

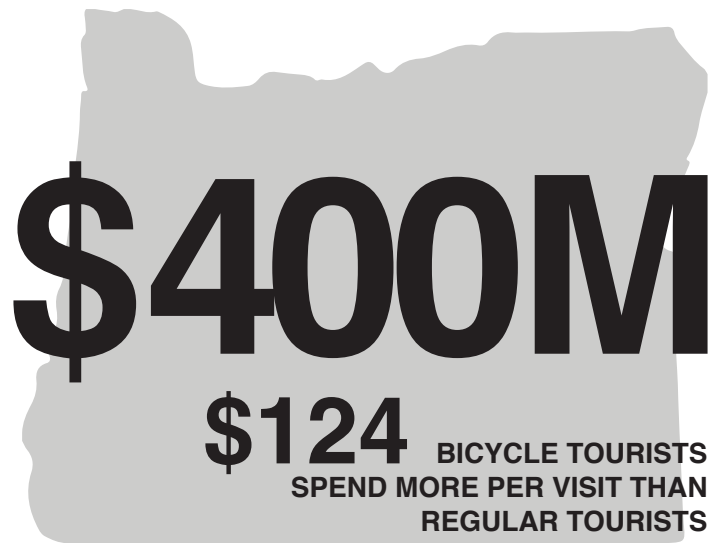

In 2012, an estimated \$400 million was spent on travel expenditures relating to bicycles in the state of Oregon. The breakdown of these funds was similar to Washington State with the top five contributions going to food and groceries, fuel, event fees and cycling gear and repairs. Roughly 4,600 jobs are supported by the bicycle travel industry contributing \$102 million in earnings. Further, \$18 million contributes to taxes.

The Oregon report also found data relating specifically to bicycle expenditures beyond day trips. It is estimated that bicycle travelers spend \$124 more per trip than an average traveler. Overnight cycling trips also generate 3 times more spending than cycling day trips. In terms of independent bicycle touring expenditures, it is estimated that in 2012, \$35 million was spent relating to these trips. An additional \$27 million was generated from group bike touring trips in the same year.⁵³

In other parts of the country, research shows a consistency in bicycle related spending. Researchers found that bike touring in North Carolina contributes \$60 million annually. Wisconsin and Colorado each see an average of about \$1 billion annually from cycle travel. Iowa sees \$365 million a year from bicycle tourists. Further, over a two-year period, Iowa invested 3 million a year in bicycle infrastructure and they saw an increase in tax revenue along the route of \$21 million a year as a result.⁵⁴

Figure 61 : The bicycle tourism in Oregon was reported as a \$400 million annual industry

A simple conclusion of bike touring economics is that it generates a substantial amount of money. Cycling is big business, and people travel from around the world to bike in the Pacific Northwest and other parts of the US. But despite these large contributions to local economy, very few people are aware that is happening in their backyard, let alone throughout the United States and around the world. The signs are literally missing from this industry. Traveling through any part of the United State and you will find evidence of car travel in the form of gas stations, rest stops, motels, diners, and car parts on the side of the road. Although bike travelers contribute substantially to local economies, the infrastructure is missing for their industry and thus the real potential of their contributions is nowhere near realized.

It is difficult to pinpoint the demographics of cycling tourists. Primarily, it is a challenge because touring cyclists travel solo, stay in tents and come and go as they please. Although some tourists participate in organized rides and others stay in bed and breakfasts, it is difficult to know exactly whom the average touring cyclist is. With that said, there are a few pieces of evidence that give some clues to who tours via bicycle in the US.

Adventure Cycling Association, the leading advocacy group for touring cyclists has a base of about 48,000 members whom they have demographics for. 78% of these members live in the US and 78% are male, and 78% take day trips via bicycle. 62% take trips ranging from 4 days to 2 weeks. And 80% plan on taking a bicycle vacation in the next 12 months. Despite the state of the current economy, 68% say they have planned a trip and are going to take the trip. The median income for the ACA members is \$81,500 and 80% have a college degree. They live in households of one or two cyclists, and 52% have 3-5 bicycles in their home. The top majority of bicycles owned are road bikes, touring bikes and mountain bikes. Of the trips taken, 99% are on paved roads and streets, 83% on paved bike paths, and 54% on unpaved bike paths. 42% of members report riding 3-4 days a week and 32% ride 5 or more days a week.⁵⁵

Cycle Tourist Demographics

The 2012 study regarding bicycle travel in Oregon also identified demographics for the cyclists of the study. Of those cyclists in the study, 65% of cyclists were male. 46% of the cyclists were between 35 and 54 years of age and 26% were between 55 and 64 years old. 78% of cyclists had bachelors and masters degrees. 58% of households had annual incomes over \$75k and 9% had annual incomes over \$200k.⁵³

Since there are no rules in how one should bike tour, there is no prescribed amount you need to spend to participate. As touring styles vary, so do spending amounts. A organized “fully loaded” tour, in which a support vehicle carries all gear, allowing the cyclist to carry no weight on the bike, can cost an average of \$1200 a week, no including flights⁵⁶. And that assumes you will be camping along the route. A luxurious “credit card” true can be equally as expensive, but allow the cyclist more freedom in day to day planning and he/she can sleep more comfortably in a bed and breakfast. But you don’t get to ride in the van should you get tired or your bike breaks.

Despite the luxuries of an organized tour, or credit card touring, many people who traverse the country and world are able to do so by keeping a tight budget. A week long organized bike tour for \$1200 may be a treat for some, but some tourist could spread that budget out over a month.

Budgeting for a self-guided bicycle tour is much different than a typical vacation. If you were flying to Florida to go to Disneyworld, you would purchase plane tickets, book hotels, and have a lump sum for meals, taxis, etc. And it is more or less difficult to keep track of the total cost of your trip because some money was spent several months ago booking flights and hotels and other money will be spent later.

Bicycle Touring Budget

By contrast, many people who bike tour have a “per day budget”, meaning the total expenditures for the day do not exceed the predetermined budget. A typical budget for a self-guided bike tour might be between \$20 and \$40 per day. This makes the economics of bike touring very simple and appealing to many travelers. A typical traveler might say, “I have a week of vacation time coming up, I have a daily budget of \$30 a day, so 7 days times \$30 a day is \$210 total”. This makes bike touring incredibly appealing to many people. Comparatively, Disney World is closer to \$100 per day per person, plus flights, taxis, food, etc. How the traveling cyclist is able to keep such a low per day budget is by camping and cooking for themselves. A typical state park campsite is about \$12 a night. Daily groceries can range from \$5 to \$10 per person. Put sporadic ice cream cones, quarters for showers and ferry fees into the mix, and you’re somewhere around \$30 a day. It’s still an incredible cheap vacation by today’s standards.

There are more than 6000 municipal governments with populations between 25,000 and 5,000 in the United States. And there are thousands more with populations below 5,000. 75% of America's land is considered rural, and 16% of the US population lives in rural areas and this number is slowly decreasing. In recent years, there has been much discussion about rural economic development due to decreasing population and in turn decreasing rural economy. The International City/Country Management Association in conjunction with the National Association of Development Organizations released a series of reports describing strategies for asset-based economic development. From the ICMA's Center for Sustainable Communities, a 6-part report was released describing potential strategies including natural resources and amenities, adaptive reuse of underutilized buildings and sites, leveraging transportation networks and renewable energy sources.⁵⁸

The report defined asset-based economic development as:

A strategy for sustainable growth, as it builds upon the communities existing assets, making it a strategy for long-term, sustained economic growth and development – one that can build on economic, socio-cultural, or environmental assets. As with traditional economic development approaches, the benefits of asset-based economic development include retaining jobs and creating new jobs, increasing per-capita income, and increasing the local tax base. In addition, asset-based economic development can help enhance the community's quality of life, or sense of place. It can strengthen communities pride by building on local traditions and creating new ones. Asset-based economic development can also help build stronger regional networks.

Rural Economic Development

In one section of the report, a strategy is given to identify natural resources and amenities. The report states, "Communities can invest in recreational facilities, or look at amenities as an asset in their underdeveloped form, and look at opportunities related to low-impact outdoor activities (hiking, cross-country skiing)..." Allow the report does not directly mention it, this would most certainly include bicycling. In a case study the report gave as an example, Killington, Vermont, home of the easy coast's largest ski resort, worked to rebrand itself as a four-season recreational destination. The town invested in events that highlighted the communities assets, adapted to the market place, and created new metrics to track its economic development strategies as well as invested in online resources for booking and marketing. As a result, the town with a population of 811, was able to generate \$4.5 million through 12 annual events hosted in 2011.

Another strategy the report outlines is to use existing infrastructure and historic as well as culture resources of the town as assets. The report states, "According to US Travel Association, cultural heritage tourism contributed \$759 billion to the US economy in 2010, employing more than 7.4 million people, and generating \$118 billion in tax revenues for the federal government and state and local governments." The strategy suggests incorporating heritage into community infrastructure and amenities. These features can in turn attract many tourists who will help stimulate local economies.⁵⁹

Chapter 8:

Site Analysis

Many Roads to Roam



Figure 31: The ACA network of bicycle touring routes.

The Adventure Cycling Association has been the primary route planning organization in the United States. Many cycling tourists rely on their maps to guide them on a long distance tour through the US. Since early days of route finding as part of the 1973 Bikecentennial, ACA has mapped 27 major routes throughout the United States. Their routes and maps are specifically designed for the touring cyclist and provide the safest route between destinations. In addition, ACA routes consider the amount of traffic on the roads, the road conditions and proximity to services.

Washington State has two of the major ACA routes passing through it, The Pacific Coast Route and the Northern Tier Route. The PCR is ACA's most popular map sets sold and one of the most popular routes to tour in the US. The PCR is 1854 miles and begins in Vancouver, BC, Canada and ends in Imperial Beach, CA, just across the border from Tijuana, Mexico. The other major route in Washington State is the Northern Tier Route. The NTR begins in Anacortes, WA and ends in Bar Harbor, ME, and the route totals 4239.5 miles. As the name implies, the route follows the northern most states in the US from start to finish passing through Washington, Idaho, Montana, North Dakota, Minnesota, Iowa, Illinois, Indiana, Ohio, Pennsylvania, New York, Vermont, New Hampshire, and Maine.

The Northern Tier Route has become so important in connecting the US for cyclists that ACA has been working to use it as a base for USBR10. This designation will be explained further in the next section, but it is important to note the difference in these two routes. For the most part, the route is the same through Washington State, but there are some areas where USBR10 takes short cuts. The USBRS is intended to be an interstate bicycle route system, which for some reason does not directly indicate tourist travel. Like a car heading down Interstate 90, the route is meant to get vehicles quickly from one destination to another, and the USBRS has a similar methodology. But it is different from the NTR in that the ACA methodology is for safe passage on less busy roads and through many small towns. For an organization working on both routes, the difference is subtle but worth noting.



Figure 62: The Northern Tier Route starts/ends in Washington State.

John Pope and USBR10

John Pope was a mechanical engineer for Shell Oil for 21 years before he retired. But his true calling began after retirement. John volunteered his time working with local bicycle organizations such as Cascade Bicycle Club and WA Bikes. He would come to serve on the board of WA Bikes and Cascade Bicycle Club. John also began creating bike maps of his local surroundings in the Skagit Valley. Things started to take off once Adventure Cycling Association got involved in John's mapping projects. Along with Barb Chamberlain, a fellow board member with WA Bikes, they formed a committee and partnered with WSDOT. John would spend the next three years volunteering his time to determine the official route of USBR10 through Washington State.

USBR10 will eventually cross the country from Washington State to Maine. The US Bike Route System is a series of interstate roadways connecting from state to state. Through this network of routes, cyclists will have designated paths determined to be the safest and best travel via bicycle through each state. Presently, there are about 11,000 miles of routes under the USBRS and a goal of 50,000 miles when the system is complete. Currently, USBR10 has been designated in seven states, and thanks to John Pope, Washington State and Idaho have been designated.



Figure 63: John Pope was heavily involved in designating USBR10 in Washington State.

For a route to be designated, there is a list of criteria that it must meet. The route must connect two or more states, an international border, or other US Bike Routes. In addition, vehicle miles of travel (VMT), several other factors form route planning. John looked to ACA for guidance. Some of the basic considerations that ACA looks at are shoulder conditions, low use back roads, proximity to services such as food, water, bike shops and lodging. John based most of the route on ACA's already established Northern Tier Route.

One important take-away from this is that the power of even a single volunteer should never be overlooked. It is plausible to say that without John Pope USBR10 may not yet be designated in Washington State. When you look at a map of the proposed and current state of the USBRS, there are many gaps in system yet to be designated. Mr Pope explained to me that each municipality along the route must agree to the designated route. It was a tedious process to overcome, but persistence pays off in the end.

Most importantly, creating aware of bicycle tourism is crucial to the success not only of the system as infrastructure but also economic development. Once some traction begins to take hold, it should become easier for municipalities to see the benefits of designated bicycle routes.

Washington's Many Routes

Beyond the two major national routes, Washington also contains several routes circling within the state. ACA has mapped the Washington Parks Routes which circle around the Olympic Peninsula and North Cascades Mount Loop, respectively. Each route connects to other routes and could be combined with other routes for many variations of travel.

In terms of mileage, Washington State has thousands of miles of routes for cyclists. The PCR section within Washington between Vancouver, BC and Astoria, OR is 401.5 miles. The NTR between Anacortes, WA and Sandpoint, ID is 457.5 miles. The Washington Parks Routes have a combined total of 863 miles. And there is the John Wayne Pioneer Trail which spans 253 miles.

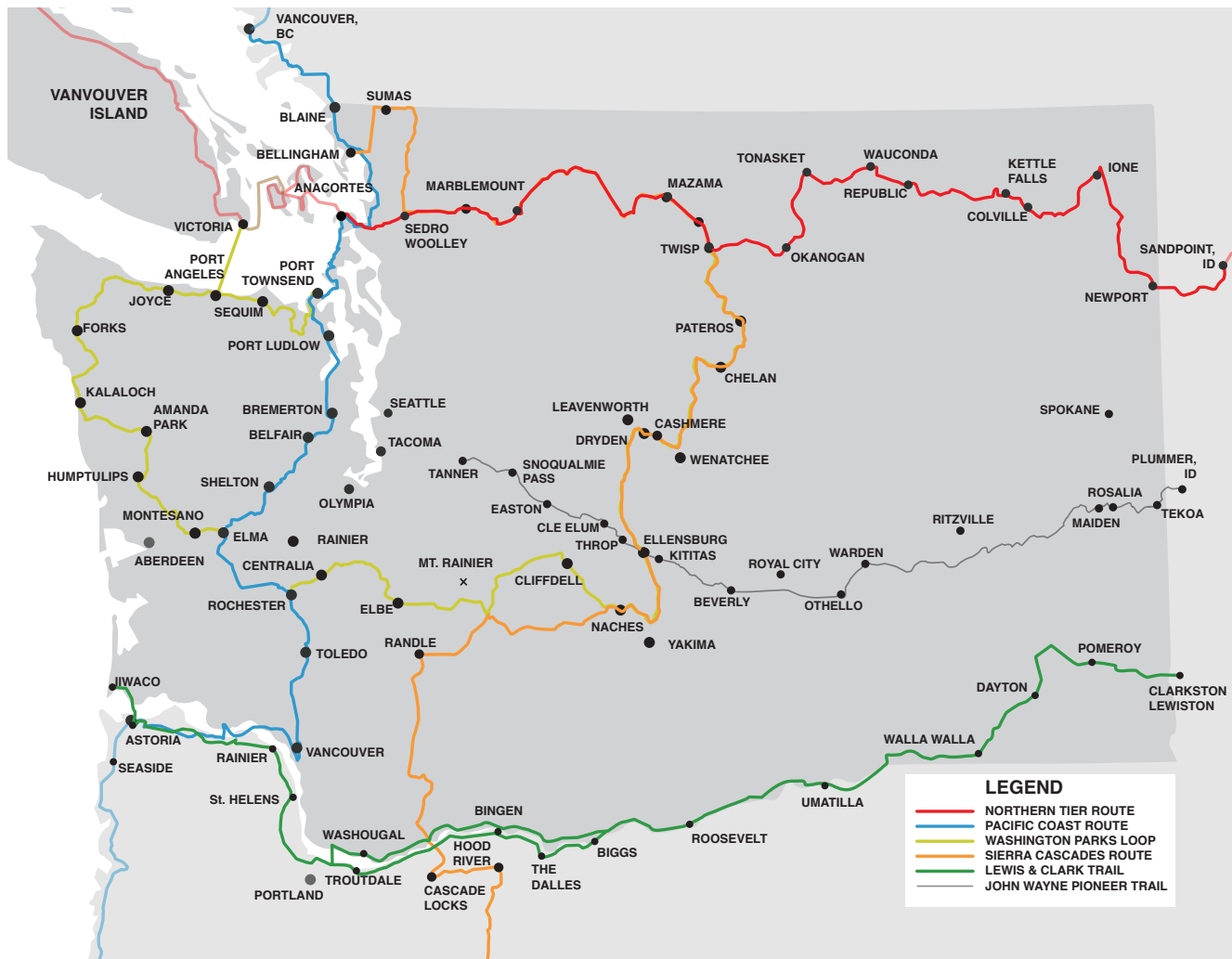

Figure 64: Major bicycle routes throughout Washington State.

The JWPT is different from routes for several reasons and should be designated differently. It is a primitive trail composed of ballast, crushed stone and sand. It is considered the longest rail-trail conversion in the US and passing through a 100 year old train tunnel spanning 2.3 miles. The tunnel was recently reopened for recreational use along the John Wayne Pioneer Trail and is considered the longest recreational tunnel in the US. The PWPT is mostly on public land, passing through Iron Horse State Park and features four primitive campsites. According to Rails-to-Trails Conservancy, the trail also has a section through Washington State Department of Natural Resources land between the Columbia River to Lind, WA. DNR requires travelers to register for a permit to travel through this section of land. East of there, between the Idaho border, the trail is further maintained by Washington State Parks and there are some sections where the trail is interrupted for miles. However the condition, there are many cyclists who ride parts of this trail throughout the year. During summer months, there have been bus shuttles on parts of the trail allowing cyclists to ride the trail in one direction and return to civilization by evening.

The issue with the JWPT is the trail's condition and considerations to ride it mean that it is too underdeveloped to be a viable case study in this project. The trail requires much maintenance and parts of the trail have interruptions, causing cyclists to navigate around them. In addition, the surfacing of the trail will be a deterrent to cyclists who wish to do high mileage days on a smooth road.

Fortunately, Washington State has many well paved roads criss-crossing through some of the most beautiful terrain in the US. From roads along the ocean side, to mountain passes and desert valleys, Washington State is like a touring cyclist's dream playground. The ACA routes are the best examples of road touring in Washington State

Route Connections & Nodes

Routes become more valuable when they are connected to other routes. And especially so when they connect to beautiful and peaceful ones. When studying the routes of Washington State, the intersections of the routes become clear. These connections are important for several reasons. These intersections become nodes along the route. They allow cyclists to change course of direction. Like a choose your own adventure novel, the touring cyclist is truly given an opportunity to choose his/her own adventure. These nodes offer refuge, should the cyclist want a hotel room for a night. They have at least one bike shop and other services. The nodes are also important in consideration to one another. As a touring cyclist plans their journey, it is best to pass through these nodes often to resupply or for a warm meal or comfortable bed.

When considering the ACA routes within Washington State, several route nodes become apparent. These cities and towns include: Anacortes, Twisp, Ellensburg, Rochester, Port Townsend, and Port Angeles. One of the cyclist's concerns should be the distance between these nodes. In this case, the average number of miles between these towns is 110 miles. Some cyclists can ride this distance day after day, continually connecting their route and travel accommodations. However, this is not a common average daily distance of a typical touring cyclist. To explain this, it is important to understand who the average touring cyclist might be and how many miles that user is likely travel per day.

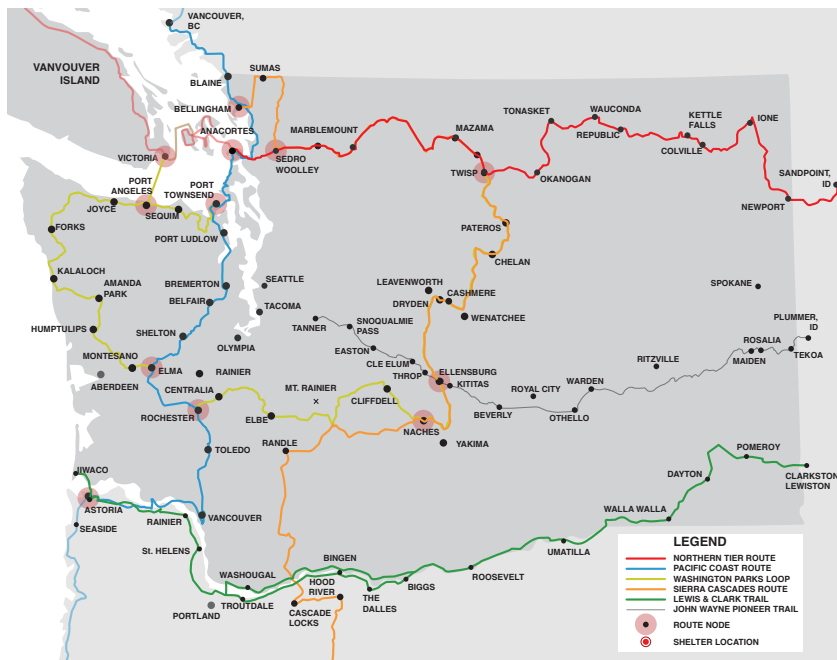

Figure 65: Route Nodes in Washington State.

Cycling Distance and an Average Interval

When considering public infrastructure, the lowest common denominator is often a factor. Ideally, the infrastructure would accommodate all users. This would mean placing cycling specific structures on an interval that serves all cycling demographics. For this project, we will assume that the least distance a cyclist will go without some form of shelter would be 30 miles. This would mean a place to stop and rest, get water, eat something and possibly sleep. If the rest stop also had basic bike tools, this could relieve the cyclist from carrying certain tools and unnecessary weight. About 30 miles becomes the shortest distance for needed shelter of even the most primitive kind. Given the ACA routes in Washington State, many of these feature stretches of road without services for this length and often longer. Along the NTR, through the North Cascades Mountain Range, not only is the terrain challenging, but there are very limited services for almost 80 miles between Marblemount and Mazama, and even further to closest bike shop. Given this system, almost 3 stops would be necessary to accommodate the touring cyclist through this section.

But what about the average we already established, a cyclist who can peddle for 6 hours a day at 9.6 mph. This cyclist will end up traveling an average of 57.6 miles in a day. And conveniently, this is almost four times the distance of the shorter internal cyclist. So the average user will pass by at least three bicycle specific rest stop before stopping at a second one for the night. This is convenient on many levels, both in terms of distance between services but also as a midday resting point en route.

Finally, there are those who can ride 110 miles between node towns in a single day. Conveniently, this is about 4 times the shortest interval and about twice the average cyclist’s daily mileage. For these users, they will pass four much needed rest stops before arriving at their destination for the night.

This system of intervals, 30, 60, 90 and 120 miles becomes important for establishing an infrastructure for cyclists. For the system to work for efficiently, it would need to work on an interval system such as this. If the interval is in distances of 30 miles, it would accommodate all users as well we create flexibility in travel. When the 120 mile a day cyclist decides to take it easy, he could pick any of 4 distances to ride and still stay at one of the bike specific rest stops.



Figure 66: 30 Mile Intervals along the NTR in Washington State.

But the interval should not be exactly at 30 miles, as this may not always be feasible. In fact, if you look at a map of the NTR through Washington with the projected 30 mile intervals, the towns along the route are +/- 10 miles of the 30 miles. Since towns are vital to the cyclists ability to refuel water and calories, it would be wise for the shelters to be as close to the towns as possible, if not in them. Contextualizing the shelter locations allows the shelters the support and security offered by the towns. The closer the shelter is to the town, the more the town will benefit economically. Additionally, if the shelter is in the town, the cyclist does not have to bike additional mileage to get to the town, maybe they could walk to the services, stores, cafes, etc that they are seeking.

When examining the contextualized shelter map of the NTR in Washington, both the shelter locations have been adjusted to the closest town, and the distance between each town are apparent. In some cases, like between Republic and Colville or between Ione and Newport, there is mileage well beyond the 30 mile interval. And in these cases there would be a need for shelters between the two towns to make the mileage more manageable. From this we can gather that there are at least two, if not three, types of shelters necessary: one type would be the type in towns and the other would be in rural settings. The third type might be in a dense city environment, which might require a different set of strategies for the shelter, but there will be more on that later. For now, it is worth noting that the shelters will be close to 30 miles apart, but the distance can vary +/- 10 miles in some cases.

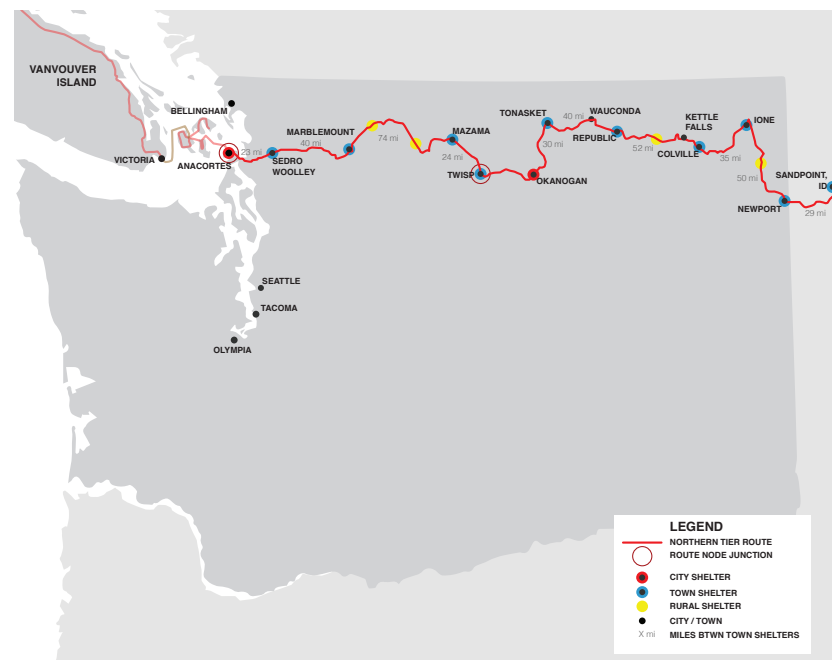

Figure 67: Contextualization of 30 mile intervals showing shelters in cities, towns and rural environments.

Climate and Seasonality of the Case Study Route.



Figure 68: Cyclists are highly affected by climate and weather.

The shelter locations will be subject to every weather condition and terrain type within the US. These shelters will be at sea level, as well as thousands of feet in elevation, nested deep within mountain ranges, and in desert climates also. Further, the system should be designed to allow for travel year-round.

But, there should be a note about cycling season. As most would assume, cyclists tend to emerge when the sun does. Within the Seattle area, springtime marks the beginning of bike season. In April, the rainstorms let up and cyclists hit the streets in heavy numbers. Likewise, the touring season is typically the summer months. As most US residents take holiday vacation time in the summer, this would also apply to bicycle touring trips.

When considering the system across many states, each region has different geography and weather patterns. This means that shelters will need to be considered on a case-by-case, or region-by-region basis. When considering the Pacific Coast Route from Vancouver, BC to Tijuana Mexico, there are different climates and geography to consider along the route, and the shelter design in Washington State would be different than Southern California.

What this also means is that some regions might be closed part of the year due to snowfall or other conditions. While in a southern region, routes may be open year-round. Just as birds migrate south for the winter, so do cyclists. In Washington State, there is a decrease in ridership in winter months. But in states closer to the equator, cycling levels can be maintained year-round. What is important about this is when considering the whole cycling route system within the US, some parts will be used year-round while others might be desolate in wintertime.

In Washington State specifically, we see this on a micro scale. Few areas, such as the San Juan Islands, can be toured year-round, with a rain jacket and a warm sweater. And other areas are closed completely. In the case of HWY 20 between Marblemount and Mazama, through Washington Pass, the road is actually closed between October and May due to road conditions, avalanches and safety. Cyclists have some touring options in Washington State during winter months, but again, most are likely to head south during this time.



Figure 69: The Cascade Mountain Range splits Washington State into two climate zones.

Washington State is split into two climate zones. To the west of the Cascade mountain Range, the climate is of a marine type. And to the east of the Cascades, the climate is a mixture of continental and marine. The Cascade Range blocks many of the storms coming off the Pacific Ocean, resulting in wet and cool conditions on the west of the mountains and dry and warm conditions to the east. When looking at the climate of the Anacortes area, the city has an annual average high of 59.6 degrees Fahrenheit and annual average low of 44.3 degrees. The annual precipitation amount is 27.85” of rainfall. These averages are similar to Seattle which has an annual high/low of 58.8/45.1 and an average precipitation amount of 34.1”. For further comparison, the town of Republic WA has an annual average high/low of 56/32 and average precipitation is 16.94” In addition, Marblemount has an average high/low of 58.8/41.1 and an average precipitation of 76.01”.^{71 72 73 74}

In terms of elevation, Washington State has diversity from sea-level to over 14,000’. Anacortes has an average of 20’ in elevation. Marblemount is 322’ in elevation and Republic is at 2602’.

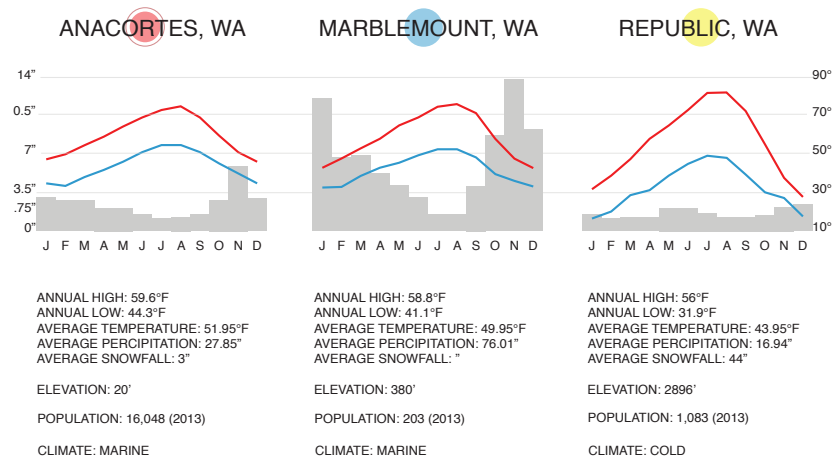
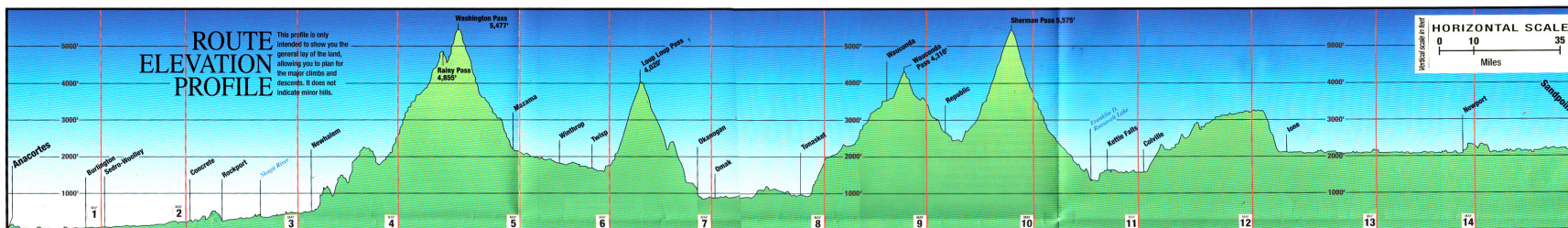

Figure 70: A Comparison of three potential shelter locations along the NTR in Washington State.

Figure 71: A Route Elevation Profile for the NTR in Washington State.



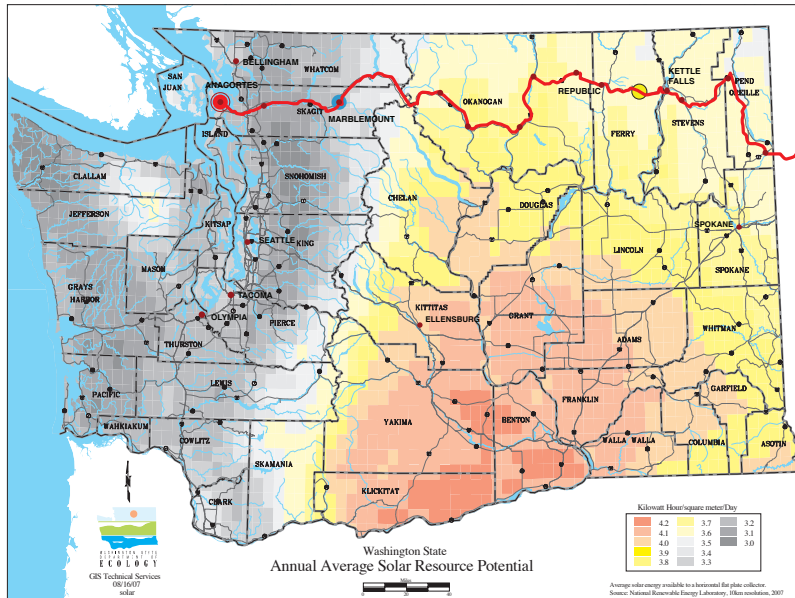

Figure 72: Solar Resource Potential of Washington State

In terms of daylight hours, most of the Washington State section of the NTR is at the same latitude, resulting in similar daylight patterns. Daylight in this area can be quickly summarized into the amount of daylight hours throughout the year. The summer and winter solstices are important metrics, and the rest of the year swings between these two extremes. On the summer solstice, the number of daylight hours expected in 2016 is 16.07 hours. The winter solstice of 2016 is expected to be 8.18 hours.⁷⁵

In addition to the amount of daylight on the solstices, it is also important to consider cloud cover. This data was split into two sets, divided by the west-east by the Cascade Mountain Range. In Bellingham, 17 miles northeast of Anacortes, has an annual average of 5.6. More than half of year is overcast with an monthly average of 16.8 days compared to 5.3 clear days a month. In Omak, 40 miles west of Republic and 27 miles east of Twisp, sees almost the complete opposite as Bellingham. Omak has a cloud cover average of 2.9, with a clear sky average of 17.2 days a month and an overcast average of 5.5 days out of the year. This in turn means that the Cascade Range blocks most of the clouds coming from the west, making eastern Washington State much sunnier than the western side.⁷⁴

What can be summarized from this data are three things:

1. The Washington State section of the NTR is partially closed in winter months and the route is most likely to be used during summer months. 2. The study area within Washington State has a mild climate with an average June temperature range between 70.7 degrees Fahrenheit and 48. There is a negligible amount of rain in this month, but throughout the year, some of these locations get a large amount of rainfall. In terms of harvesting rainwater, it will be important to collect water through the winter months to support the summer cycling season. 3. The amount of daylight hours in this region is great during summer months, which will benefit the photovoltaic panels and harvesting solar energy. In considering the amount of daylight hours, cloud cover becomes a factor, and simplified, eastern Washington State gets twice the daylight as the west. This makes the east more viable than the west for solar energy systems. But the west is more viable for rainwater collection than the east.

Navigation Along the Route



Figure 73: Some cyclists rely on the aid of GPS units for navigation.

It may bring anxiety to some cyclists when thinking about traveling for hundreds or thousands of miles without a confirmation that they are on the right path. Having an ACA map of the route is crucial, but often the map is not enough information. In the case of the ACA maps, it does a great job of helping a cyclists navigate a very specific route and identifies services the services is likely to seek. But this is a different type of map altogether, tailored specifically for cyclists on a specific route. A standard road map shows a region and as many highways and roads as the scale will allow. Some maps are tailored for recreation and may show destinations such as campsites, RV parks, etc. The fundamental difference between an ACA map and a regular road map is that ACA has prescribed the path of travel and a regular road map leaves that up to the traveler. What this means is that a regular road map can take you to more places, but an ACA will take you one place relatively safely.

A few other assumptions need to be made about the cyclist and his/her preparedness for travel. In some cases, cyclists have GPS units to help guide their way. This can be helpful for way finding as well as gauging relative distances to destinations, etc. However, GPS units are not always desired for several reasons. First, like all items with batteries, the battery will eventually die. In top shelf bicycle specific GPS units, battery life ranges from 10 hours to 20. So every two or three days of riding the battery needs to be replaced or charged. Further, the unit itself may not weigh much, but include batteries and applicable accessories, and the cyclist has several more ounces of weight to carry. Lastly, the GPS unit is likely to be the second most expensive piece of gear following the bicycle itself. For some cyclists, this added cost could translate into an additional week or two of travel and many would see it as too high of a price for little added value.

But, the world is changing and we have more technology now than ever before. For most cyclists, a smart phone is all that necessary for information and way finding. In many cases, a smart phone is the best piece of gear to bring along due to its versatility. It is a GPS-like map, camera, internet browser, and phone, etc. But the issue with this device is two fold. 1. The battery will die eventually and if used for mapping, will require frequent recharging of the battery. 2. The phone is subject to cell-phone service, and in many remote areas will be useless without service. Cell phones become useful in towns and cities, and less so between them.

This concludes that the most reliable source for way finding is a physical map. A prepared cyclist may have more than one map of an area, in case they want to detour from the main route. But this can also add weight to cyclists luggage. The ACA NTR route is divided into 11 sections, each contained in it's own map. If the cyclist adds some other maps to this collection, it not only weighs them down, but it becomes a volumetric problem also as space in panniers is limited.



Figure 29: ACA Maps are common to be used and seen while bicycle touring

Chapter 9: Methodology

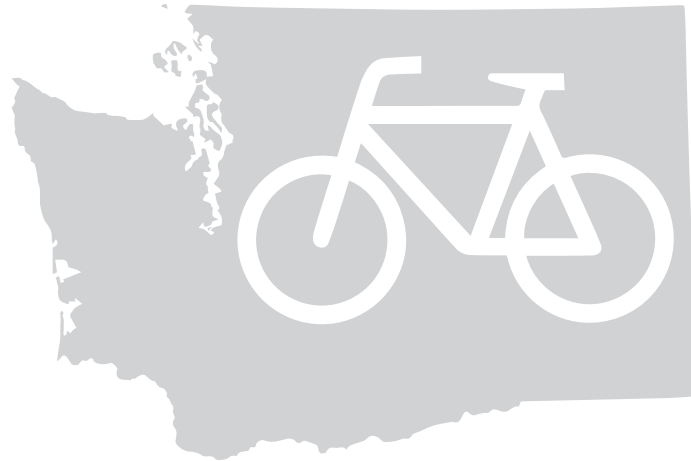

Figure 74: The ACA network of bicycle touring routes.

To summarize what we know about bicycle tourism: 1. We know that bicycles are a common form of recreation around the world and many people choose to travel by bicycle. Within the United States, the recreational cycling market is continually increasing and in 2014 almost 60 million people rode a bicycle at least once annual bicycle sales alone were \$5.2 billion. Within Washington State, the bicycle industry contributed \$3 billion

What We Know

to local and national economy. Due to the nature of travel by bicycle, cycling tourists frequent small towns and have an impact on local economy. 2. Cyclists have minimal and in some cases, no services along their travel route. The most common services tourists cyclists seek are water, food, restrooms, and some form of shelter. Often, cyclists must travel several miles off route to reach services. 3. Many touring cyclists camp along the route, often at state parks or RV parks, and in many cases along the road illegally. Staying in hotels every night is not always feasible or often desired. 4. People of all varieties travel by bicycle, from retired men and women to families with children as well as recent grads. 5. Many national routes have been established throughout the US. Some are becoming nationally designated, and many are routes that have been mapped. But beyond the map, there is nothing that would indicate the route physically. Cyclists travel on the shoulders of highways and follow car traffic from one town to another. 6. Successful case studies exist proving that if you provide shelter along popular routes, cyclists will come in numbers. 7. Bicycle tourism within the United States has an international draw. Thousands of people travel from around the world to ride such routes such as the Pacific Coast Route or the Northern Tier Route, both of which cross through Washington State. 8. The climate in Washington State is both marine and continental. Cycling occurs year-round, but most cycle tourism tends to occur in the summer months due to weather and road conditions.



Figure 75: Giving cyclists an identity the the main goal of the project.

What is Proposed

The main goal of this project is to serve a minority of tourists who travel by bicycle through the US. This service comes in the form of shelters strategically placed along popular transnational routes. A secondary goal of the project is to help revitalize rural towns along these routes. With an international eye on tourism and cycling, Washington State could serve as a pilot for this system, which by nature needs to continue to grow, both along the route and internationally. The towns along the route will benefit from the economics of bicycle tourism.

The methodology for this proposed project is a series of shelters, placed at regular and strategic intervals of 30 miles along the Washington State section of the ACA Northern Tier Route. The shelters will vary in scale and program depending on context. The scale ranges from basic rest-stop to a facility that can house two dozen cyclists. By nature, most of the shelters will be in remote areas and will need to be self-contained. This would include electricity and plumbing. In turn, the shelters would be highly site responsive, both in terms of services, materials, program and overall architectural design. Although the shelters will need to be climate and site responsive, there is a need for them to also be replicable, durable and relatively inexpensive. This could mean a modular system or guidelines to build the shelters in a particular way as to create a connection between the shelters. To further unify the system, bicycle related art could be installed along with the shelters to create a scene of identity and branding to the system.



Figure 76: An arch made of recycled bicycles. Bicycle art can be used to create identity and presence for the infrastructure.

Program and a Place to Sleep

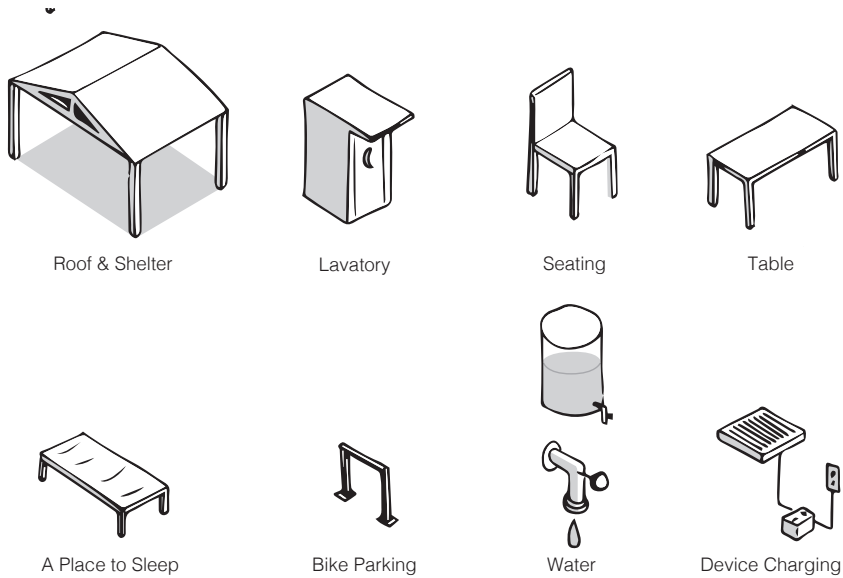

As the shelters range in scale, the program changes scale as well. For the most part, the different scales of shelters each have a similar program that is repeated. Base programmatic elements include water, seating, table, lavatory, electric device charging station, and bicycle repair. But as the scale increases, the base programmatic elements are added to with elements such as bunk beds, stay rooms, social gathering space, kitchen and dining space, laundry facilities, and fire pits.

Figure 77: Programmatic elements and services offered in the proposal.

To think about the program in terms of sleeping would be crucial. The entire system is ultimately to provide cyclists a place to rest and sleep. Each shelter needs to provide at least some place to sleep, be it grass, sand, floor, or bed, the success of the system assumes cyclists can sleep at the shelter location.

Should a tired cyclist find him/herself stranded in an isolated area, dozens of miles from the closest town, they could be in a very dangerous position. But, the proposed system is designed specifically to serve the touring cyclist in this exact scenario. Should that cyclists happen upon the shelter system, they would have all they would need to safely recuperate and sleep in a designated area for them.

In the smallest scale, this sleeping area could be the grass or sand next to the shelter, where the cyclist could pitch his/her tent. Or it could mean they sleep on a bench or cot in the shelter. It would not necessarily require the shelter to have a room to sleep in, but nearly a safe place to sleep. Since most touring cyclists travel with camping gear, it can be assume that this semi-primitive camping shelter would not only work, but it would provide many more luxuries than a camper is use.

In the medium scale, a more substantial shelter is necessary. As the shelters get closer to towns and cities, the likelihood of there use will increase, given that there are more cyclist in the area and the area itself is a desirable destination. In this case, it is possible that a family may be traveling together is seeking shelter

for the night, as well as several other cyclists who happen to be passing through the area. The shelter should ideally accommodate as many people as possible, without forcing anyone to camp outside or travel to the next shelter. To maximize the number of beds, create a social atmosphere and keep construction costs down, a bunk house style shelter would be desirable. A large open social space with modular furniture becomes more like a rural hostel and can accommodate a dozen travels. The social space could be centered around a view or fire place and designed to stimulate interaction between travelers. As many travelers love to share their stories with others, this space and sleeping arrangement would allow users to connection with one another and be more aware of fellow travelers.

In the largest scale, the route has identifiable nodes and points of interest where an even larger and more flexible shelter space is necessary. In these node locations, shelters are likely to be used most often within the system and throughout the year. These important node locations become destinations in and of themselves and offer more vitality than the other shelter scale. In touring there are many guided tours a cyclist has the option of taking, and for many cyclists this is the only type of tour they are willing to do. Further, these tours tend to occur in desirable places, be it scenic or road conditions, but people travel the world to participate in guide tours. In this system, the largest scale would likely coincide with such places and become hubs for such guided

tours. The advertisement for such a tour could read, “Come to Anacortes, WA. Stay in the iconic cycling shelter and take day-rides through the beautiful Skagit Valley,” and cyclists would be intrigued. But, this marketing strategy would be secondary to those individuals who just cycled from Maine and beyond to stay at the iconic cycling shelter in Anacortes. What this ultimately means is that the shelter would be buzzing with traveling cyclists. From locals on a weekend getaway from Seattle, to those who spent many weeks traveling across many states, the node locations become a major hub for all traveling cyclists. Thus, the need to house a few dozen people at a time is necessary. Similar to the bunk house model, an open space for many beds in a single space could work. But the need for stay rooms may also be expected. And, this would be a shelter that should separate its social space from its sleeping space, to allow the many visitors both privacy and the ability to connect with others.

Design Goals and Considerations

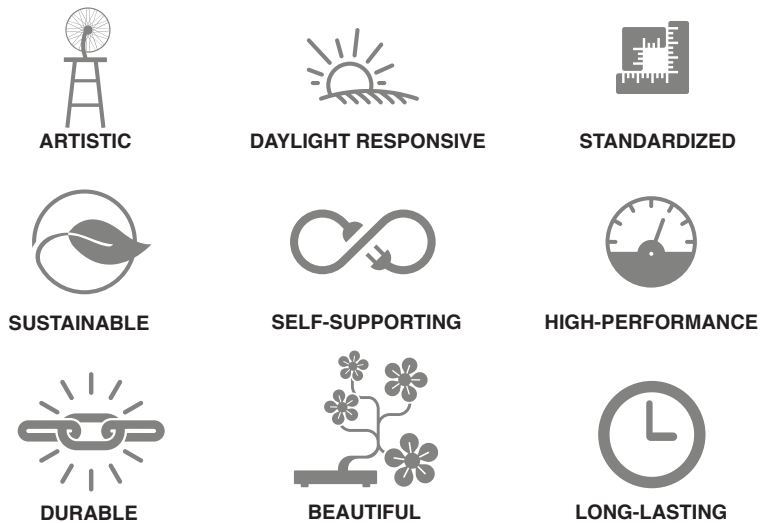

Figure 78: Design Goals and Considerations.

Many of the buildings in our society have a relatively short lifespan. Our transportation infrastructure has a similar lifespan. For example, the average expected lifespan of asphalt is 25 years. Which results in poor road conditions after only 20 years of service and a considerable financial and environmental investment on a regular interval. What this means when proposing public infrastructure is that durability and longevity are important factors to consider. In all public works projects, the longer an item lasts the better for users and taxpayers. There is a variable of quality and consideration when designing a structure, some could need frequent maintenance and replacement while others are built to last. One example of public works designed with durability and longevity in mind are some National Parks buildings, several of which are almost a century old.

When considering a public infrastructure for touring cyclists, durability, longevity and simplicity are important factors. The structures could last for many generations if designed to. The list of design goals for the structures would include: use of sustainable materials, little environmental impact, durability, maintenance, longevity and beauty.

Modularity and Prefabricated Design

When considering the deployment of an infrastructure of shelters throughout a state or nation, some amount of standardization is in order. There are additional considerations including ease of installation, rapid deployment, environmental footprint, longevity and appearance. The system should allow for flexibility in terms of size and program. If a basic shelter provides lavatories, water, shade and a place to pitch a tent, a fully featured shelter might include enclosed sleeping rooms and seating space, covered bicycle parking and repair and additional services. The shelters could be based on a structural system and material properties that allow for easy expansion.

The first step might be to say that the system could be prefabricated in a controlled and automated fashion for simplicity and efficiency. This would employ a warehouse with the means to build each structure, and then ship them to each site for final assembly. The system should be designed for simple erection so that a local construction crew with experience in light frame construction can install each shelter.

The construction constraints are then beneficial in both design and construction. This method of production allows for a closed loop of communication between construction and design whereby both improve over time through their involvement and communication. Further constraints could be added in terms of material, structure, and construction to benefit the end users and build responsibly.



Figure 79: Prefabricated Construction in a factory controlled environment.

Figure 13-2. Net growth and removals of conifers in the United States, 1952–2006.

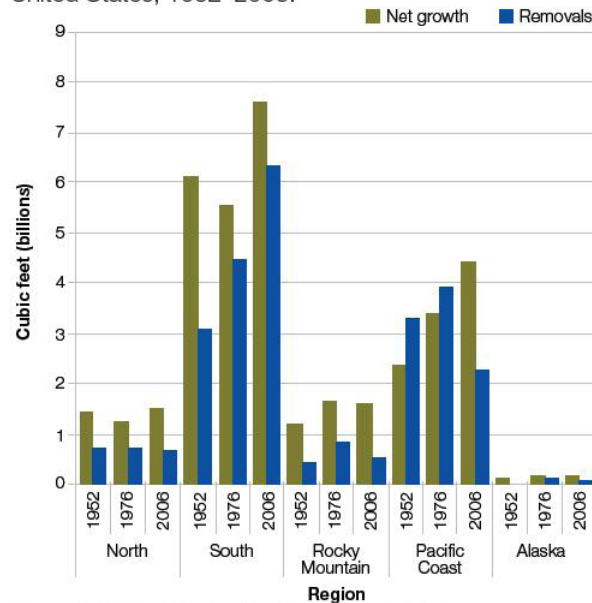

Source: USDA Forest Service, Forest Inventory and Analysis

Figure 80: US Forest Service chart shows growth and removal between 1952-2006.

Material Considerations

In terms of materials for the shelters, there is no better and more sustainable option than wood products. In the United States, 72% of the original forest cover remains since Europeans settled in North America. And Canada still has 91% of their forest cover. Further, in the past 50 years, less than 2% of US standing tree inventory was harvested. But, in the same time period net tree growth was 3%.⁷⁹ In most regions of the United States, tree growth exceeded removal.⁸⁰ Wood is a renewable resource native of the area which offers a simple and elegant material choice for structure.⁸²

One of the most important factors contributing to the selection of a structural material is the embodied energy of the material itself. This could be thought of as the amount of energy resources used to produce the material in question. For example, kiln dried hardwoods and softwoods some of the lowest energy amounts of building materials, (about 40 GJ), and steel has a relatively high amount (140 GJ), while concrete has one of the highest amounts (about 210 GJ). What this means is that the design should limit the use of materials with a high-embodied energy and use more of the materials with low-embodied energy. Further, in terms of labor and installation, cast-in-place concrete requires much more labor than wood assemblies. The embodied energy for a cast-in-place floor is about 640 MJ/m² while an elevated timber floor is about 293 MJ/m².⁸¹

Structure and CLT Panels.



Figure 81: CLT Panels ready to ship.

When choosing a building structure from wood, there are two common choices, there is light frame construction and there is heavy timber construction.⁷⁶ Both have their benefits. Heavy timber construction may require more on-site labor and skilled labor than light frame construction. Further Although the material is available, heavy timber may require more time for trees to grow and be more expensive than standard lumber. Light frame construction uses 2x material that can be sustainably grown and readily available.

Construction methods and technologies has tried to bring the gap between heavy timber construction and light frame by introducing engineered wood products as an alternative. These members have the size and benefits of heavy timber but be manufactured from conventional lumber.

Cross Laminated Timber is a relatively new construction to American. Europe has been using CLT for 20 years,⁷⁷ and the first CLT manufacturing facility in the United States open about 4 years ago. There are now two facilities in the US who manufacture CLT panels, SmartLam in Whitefish, Montana and and D.R. Johnson in Riddle, Oregon. CLT manufacturing is showing signs of demand and the relatively new material type is proving to be reliable and efficient. CLTs are light but strong, seismic, thermal, and fire protective.⁹²

The process of manufacturing CLT panels starts with a large supply of 2x8 members which are planed smooth. This allows for better surfaces to fit and bond with the glue used. An array of members are layered perpendicular to each other from 3 to 7 layers in thickness. SmartLam explained that their facility has the ability to produce panels of 10' wide by 41' long. This size also allows for large building components as well as standard transportation on a conventional tractor-trailers in America. The wood is loaded into a press for as short as a few hours before being removed and allowed to cure for 24 hours.⁷⁸

With the aid of CNC technology, the panels could be further customized in a variety of ways. Opening can be removed, surfaced could be milled, joinery components could be installed. These technologies combined with the efficiency of prefabrication means a manufacture has a group of skilled labor worker and processes that can be controlled and refined over time. This also means savings in labor in the field and to the client.

One downside to CLT is that it is still subject to weather considerations as with most wood. The panels are mostly manufactured from Douglas-fir and spruce pine SPF. These types of wood require weather protection and potential maintenance if not weatherproofed. SmartLam offers a polyurethane type liner for protecting the material from the elements. Decking could also be added to aid weathering and abrasion.

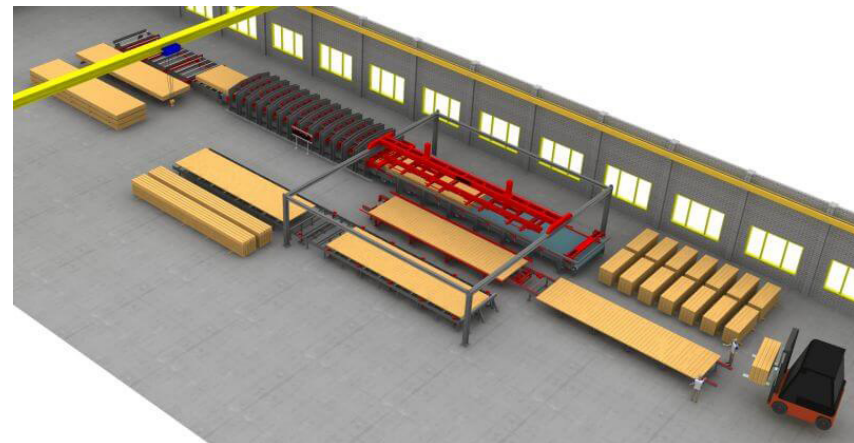

Figure 81: A depiction of a CLT press.

Material Waste and Reuse

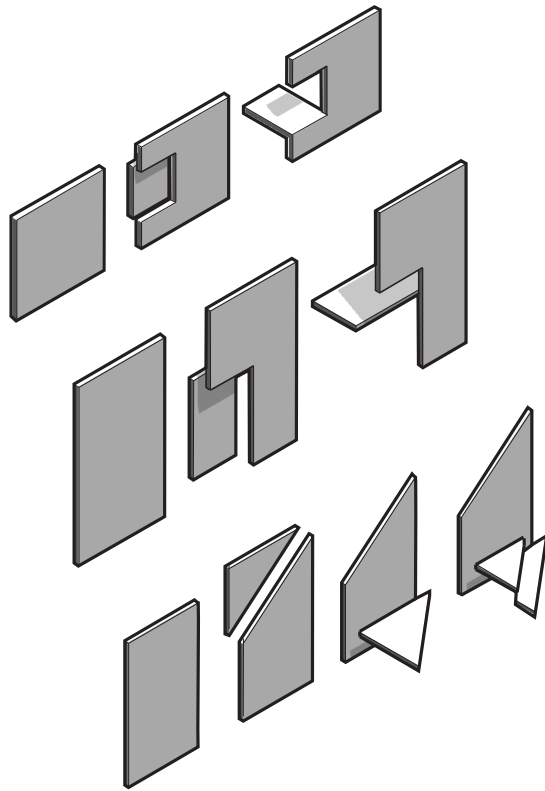

Figure 83: CLT and designing for minimal waste and the reuse of scraps.

When thinking about the design of building composed of CLT panels on all sides, there is a need to think about joinery as well as material waste. Material waste can form from scrap, edges and openings in the CLT panel. Cutting a window or door about of the panel means the negative of the outing becomes fire wood, or just waste. In terms of embodied energy and carbon emissions, burning the wood would be worst than using the material for something that could last for a century.

This proposed will make use of the wasted material generated in the manufacturing process by thinking careful about the design and looking for ways to reuse large straps of material. Since windows will be necessary for the enclosed shelters, the openings could be made so that the resulting material becomes a table. And reversing engineering openings and cuts could optimize design and experience.

Further, connections between panels can be made with common joining details. SmartLam explained that there are over a hundred ways to create connections between CLT panels. Some of those connections include steel plates, long screws and lap joints between members.

Additional Considerations

Since the shelters will be viewed and used by a variety of different users from locals to travelers from around the world, they become symbolic on many levels. In principle, they serve as a symbol of commitment to environmental concerns. With climate change rapidly changing our world, erecting a series of sustainable shelters for a minority of people who vacation via bicycle, a statement would be made towards a sustainable future. These shelters would serve as symbols and artifacts that eco-tourism is in demand and we can deliver. Further, the shelters serve as symbols of alternative and historically significant means of transportation. The shelters not only connect to our past as travelers under self-power, but they again project into the future, stating that bike touring is here to stay. What this means in terms of design strategy is that the shelters serve as a message and an idea that translates through the world. They need to be universal yet flexible, welcoming yet private, adaptable yet unique. They serve as both a tool for travelers and a topic of discussion.

Route Signage



Figure 84: A model of bicycle signage using a recycled bicycle to point north and a solar panel for emergency device charging and lighting. Signage will give distances to the nearest shelter in imperial and metric.

One of the simplest solutions to way finding is signage. A well marked path has little need for a map. But, due to the nature of transnational bicycle routes, signage is generally unavailable. Partially this is due to cyclists riding along the medians of highways and the roads themselves cater to cars. But, it is also due to the frequency that cyclists change paths. Since the best path for a cyclist is often on a back road or side street, it requires the cyclist to make constant turns and adjustments along the way to stay safe. In cities such as Seattle, which has a decent cycling infrastructure, many paths and trails are marked. A cyclist can navigate through the city and stay along a safe designated cycling path. But outside the city, a negligible amount of signage exists for cyclists.

As the US Bike Route System begins to take shape, some of these paths are being marked. However, on the USBR10 in Washington State, funding has yet to be allocated for signage despite the path's official designation. Around the Anacortes area, a few signs exist denoting the trail, but the signs quickly vanish outside of Anacortes. The reason for this is fairly simple. John Pope, who helped designate the USBR10 in Washington State, lives in Anacortes. With some persuasion, he was able to convince the city to install the signs. But, outside the city, each section of the USBR10 route falls within a different jurisdiction, requiring individual budgets and voluntary compliance to install signage. Thus, WSDOT or the National Department of Transportation has not taken ownership of the USBRS and funding and organization has been fragmented.

In an ideal world, these routes would be marked in several ways. The primary objective is way finding. As the route twists and turns, navigating through towns or back roads is common and signage would give cyclists some piece of mind. Second, signage could be used to give information about services such as the nearest bike shop, food, public restrooms, water, etc. In the case of this project, signage would be necessary to guide cyclists to the project's shelters. Signage could be used to indicate distances to destinations.

Lastly, using the strategy of incorporating bicycle art into the project's infrastructure could apply to signage. Recycled bicycles could be given a new life by being attached to signage. In some cases, this could have further implications than art. The bicycles could be hung from the sign to always point north. That way, when a cyclist comes across the sign, they can immediately tell which way is north, and which direction they are traveling.

One further consideration is how this signage should read, or in what measurement system. Many travelers of these routes are not local. It is common to see foreigners cycling through the US. And, it would be this project's intention to be stewards and good ambassadors to visitors. Take for example a tourist who desires nothing more than to cycle the Pacific Coast of the US. They spend months preparing and spend thousands of dollars in flights and shipping their gear. And in addition, they have a pocket full of cash to spend along the way. Wouldn't it be nice to welcome this person when they arrive? After all, they will be traveling alone on back roads on a bicycle. Essentially, no one will know they are there. They may buy a few maps and they are off, spending money on coffee and pie in cafes all down the west coast. If we wanted to be good ambassadors, we could provide this traveler will signage in both miles and kilometers. This might seem odd at first, but if foreign tourism is to become vital for economic development, than speaking the metric language may make these tourists more at home. It also acknowledges them and says "Welcome, we've done the math for you, safe travels and have fun." This can lead to tourists spreading the word about how international and turnkey the bike routes in America are and further promoting tourism.



Figure 85: Bicycle Art Sculpture by Donald Lipski

Recycled Bicycle Art

Beyond the need for standardized signage along the routes, there is also a need to unify the shelter system, connecting it through a central theme. If the climate conditions along the routes can change relatively quickly, the architecture would need to change to accommodate each climate. This means the shelters would not be exactly the same, and there is an additional need to tie the shelters together in some format.

If artwork became a variable theme in the system, it could have the potential to unify the shelters. If, for example, art was made from recycled bicycle frames and accompanied the shelters along the routes, the message would be clear, shelters plus bike art equals bike shelter system. Like a way finding element, the artwork would serve as a reminder that the cyclist is not only along the right path, but that the system was built for them.

Every year, tons of bicycles meet their end in a landfill or recycling facility. In the best case scenario their bike parts are recycled or melted back to metal. But, the take away here is that there are countless bicycles which are no longer of use to anyone. These bicycle parts could easily be sourced and reclaimed. A metal sculpture could be employed to weld bike frames or other parts into triumphant sculptures to be placed along with the shelters.

The bike art strategy could be deployed on various scales based on appropriateness and demand. In the smallest scale, bicycle parts could be ascents on the shelters or signage. In the medium scale, sculptures could be make into playground like elements for visual stimulation or for use from children. Art-work could be incorporated into the architecture of the shelters. Further, in the largest scale, sculptures could be used in nodes to mark the existence of the route to the public. In Anacortes, for example, a large arch could be made from welded bicycle frames and located centrally within the city. As a gateway, this town is important to the route. But the artwork would be important to the route, city and tourists. It serves as a reminder to the city that cycling tourists from around the world visit their town every year, traveling and peddling thousands of miles in many cases. It is also a welcoming element for cyclists when they arrive.

Lastly, the artwork mostly falls under marketing. If you brand it, then build it, they will come. And when they do come, there are going to photograph it and share it with many other people. The art pieces become unique talking points. If we take into account common tourist attractions, a photo of/with the landmark is standard practice. When tourists arrive in Seattle, they often find their way to The Space Needle or Pike Place Market and they take a picture the “Public Market Center” sign. Then they photograph “Rachel the Piggy Bank,” the bronze cast pig sculpture just below the sign before photographing a fly toss in the fish market. This helps market Pike Place Market as well as Seattle when the tourists share their photos.

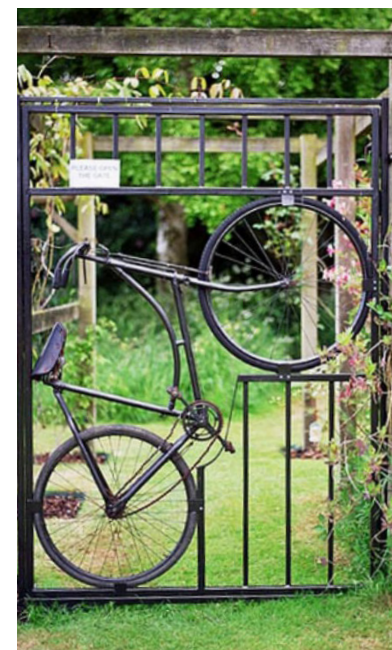

Figure 86: Bicycle Gate Sculpture



Figure 87: Tourists with Rachel the Pig at Pike Place Market in Seattle.

As digital photography has become more prevalent in today's society, we associate connections with people and places through photography on a regular basis. This would also include our travels. A cycling tourist is highly likely to have a camera and take photography along his/her journey. Mostly, these photos might be of mountain passes, remote lakes, landscape and the occasional giant ice cream sundae. But, when presented with a bicycle art sculpture on a regular basis, this begins to serve as a collection and underlying theme, all of which will be captured by camera.

The interval at which these sculptures are presented is important to consider. If done too often, it can become repetitive. But if incorporated with each shelter, it can be effective in promoting the system and its theme. Additionally, requesting regional artists make the pieces could localize artworks. Setting simple guidelines would ensure that pieces fit within the framework of the theme. Most importantly, the pieces need to fit the scale of the shelter and give a subtle reminder of their purpose of serving cycle tourism.

Chapter 10:
Architecture

Daylight Design Strategies

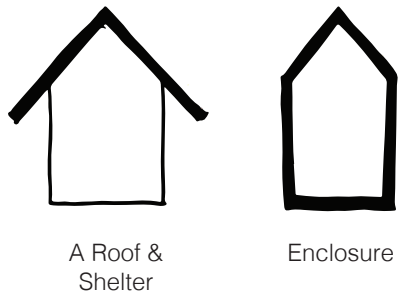

Figure 88: A roof symbolizes

When thinking of the concept of shelter, the roof is the most important component of the design. Its function is to provide shade and cover from the elements. A roof is than crucial to the design of shelter and in the case of an infrastructure system, symbolizes refuge for the users.

First, a flat roof does not convey the idea of shelter as a gabled roof does. So for the sake of this project and creating an identity for the system and its infrastructure, a gabled roof is desirable. And the pitch of the roof can be optimized for the photovoltaic panels that will be installed on them. If the ridge of the roof was oriented east-west, the pitch would be to the north and south.

In the case of shelters along the NTR, we know that the area can provide energy through solar harvesting. Photovoltaic panels can be used to capture sunlight and transfer it into DC current. This current can then be used and stored for later use. If attached for an electrical grid, it could be sold to other users. But photovoltaic panels operate at different efficiencies based on orientation and angle in relationship to the sun and sky. But, we have a fixed roof with fixed photovoltaic panels attached. And how the roof is pitched and which way it faces has consequences and benefits in terms of harvesting solar energy.

Given the latitude of the NTR in Washington State, which is between 48° N and 49° N, this and the sun's azimuth and altitude are important when considering solar orientation of the shelters. In the northern hemisphere, the sun rises from the east and swoops to the south before spending the afternoon heading west. Looking down on Earth, the sun makes a "U" shape curve which is more apparent during the summer months. For simplicity, this project proposes fixed panels that aren't going to track the sun's movements. Knowing which surface to mount the panels and at what angle is the next task.

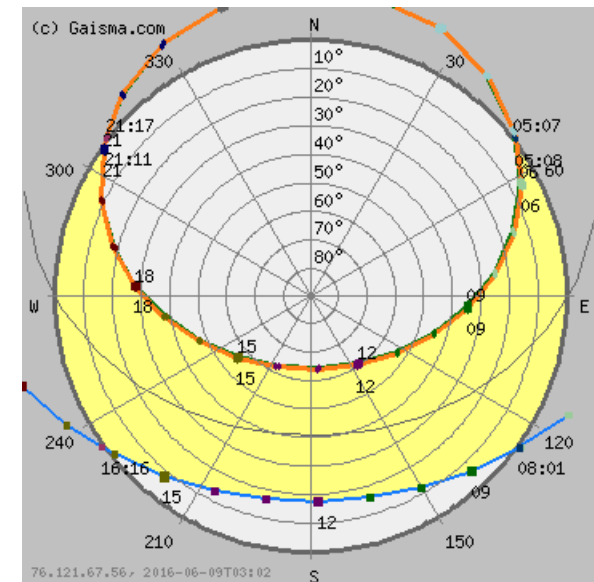

Figure 89: A Sun chart for the study area.

A photovoltaic at this latitude is about 20% more efficient if it were pitched up 40° to the south than if it were flat facing the sky. Further, if you faced that panel to the north, it would be 46% as efficient as facing the south. Facing west is 76% as efficient and east would be 79% as efficient.⁸⁶

Pitching the roof to 40° is step one, and the next step is to orient east-west with a surface facing south to place the photovoltaic array. The size of the array can be determined by demand and surface area available.

The implications of the roof and building orientation lead to choices in the openings of apertures for daylight. South facing walls tend to get the most daylight at this latitude and should be designed to block harsh sun glare. Since this facility is mostly used during cycling season, shading for winter's low sun angles is unnecessary. The high sun altitude angle of 60.5° on the summer solstice means the sun is more vertical than horizontal. And given the temporary usage of the shelters, a complicated shading system does not fit in the simple and elegant design goals set forth. Instead, a small amount of glare is acceptable and no shades are necessary. But, the apertures on the south façade should still be minimal. Apertures on the north façade should be larger than the south since only a minimal amount of direct sunlight comes from the north, and indirect light from the north can be quite pleasant. The east and west sides could be mostly closed off, as most of the light is coming from the south and north and given the east-west orientation of the building, these facades might be where users enter and exit the building.

Further consideration could be given to the depth of the building from north to south in relation to the height of the building. In section, there should be no more than times the depth of the space to the height of the space. This allows for ample daylight to penetrate deep into the space and provide even light distribution.⁸⁷

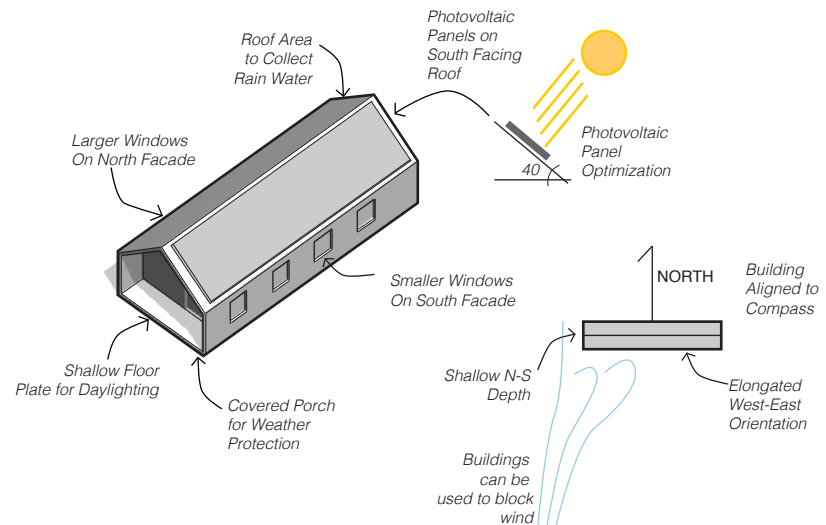

Figure 90: Climate Responsive design strategies.

Roof, Form and Enclosure.

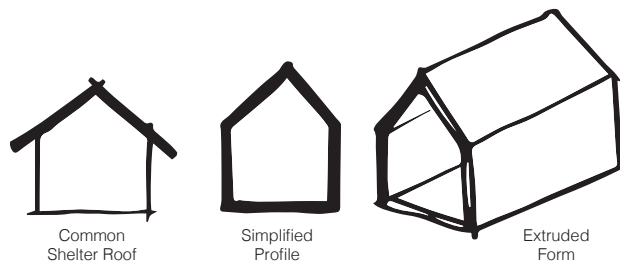

Figure 91: Roof, Profile and an extruded form.

It has been determined that a gabled roof is desirable for appearance and identity of the shelters. Given that the shelters are part of an infrastructure and network, creating a unified identity can create familiarity with users and the general public. The shelters could become iconic if the form, materials and construction were well designed and standardized.

Also, given the preferred material choice of CLT panels and prefabricated construction, the form and language of the shelters should be optimized for both materials and assembly. And given the modularity of the structure, a simple form could eliminate complicated connections and components of the building.

Beginning with the simple shape of a gabled roof supported from the ground, the form of shelter appears. Should enclosure be desired, walls could be added. With the right proportions, this shape becomes the iconic form of shelter. If this shape were extruded in the third dimension, a simple form would emerge creating shelter.

Returning to CLT construction, this shelter could be seen as either 5 or 7 surfaces composed of CLT panels. And given the current production size of the panels, having a maximum size of 10' x 41', size and proportion of the shelter could be specified and connection details could be determined. From the day lighting strategies, we know a 1:2.5 depth to height should not be exceeded, in order to provide adequate sidelighting from the apertures in the walls of the building. A 10' wall height would mean a maximum desired depth of 25'. If the depth were limited to 20' wide and the apertures be located on both sides of the space, a 1:1 ratio of side lighting would be achieved. And the space would have great natural lighting. Further, if the width of the panels is limited to 10', each framing and structural module could be set to 10' wide. So, the floor of the building, which is the largest CLT component, is 20' depth and 10', and can easily fit on a truck and requires a small crane during construction. To summarize further, the basic form of the building will have rough dimensions of 20' deep x 10' wide x 18.4' high. The height is determined by the 40° angle of the roof pitch beginning from the 10' walls.

An important feature of this modular system is its ability to combine modules into desired structures. For example, a building may be necessary to house stay rooms and seating space. If one structural unit could house a 10' x 10' stay room with bunk beds capable of sleeping 4, a 10' x 6' area for seating, and a 10' x 4' area for circulation, then one module can house 4 people in an enclosed space for the night, which is much bigger than a tent. The module could then be multiplied based on the demand of the site. So combining 4 units together could sleep 16 people. Then, should the site be optimal for a large covered porch off the side of the building, two semi-enclosed modules could be added easily and would give the appearance of a singular structure.

Modularity and a Village Arrangement



Figure 92: Program and arrangement can create positive outdoor space.

A shelter could be thought of as a singular building or it could be split into multiple structures whereby creating positive outdoor space in between the structures. There are benefits to each, but the modularity component of the design also applies to the site and demand of the shelters. Some areas are more popular than other which increases the demand of the shelters. In a popular area, the shelter could need to support a few dozen people. And in a less popular area, perhaps just the minimum to services could be offered and a place to pitch a tent.

The implications of a village design ultimately lead to a richer experience for the end user. The concept lends itself more so to the idea of camping and cabins than to the motel or hotel feel of a single building for all services. Interior circulation can take away from valuable interior space and pushing that outside would be wise. But direct doors into stay rooms can feel too much like a motel. The village concept is just the beginning of enriching the user's experience.

Some programmatic elements make sense to keep together while others could be separated. An area to cook and do dishes and an area to sit and eat make sense to be together. As do grouping of services. The shelters will have several systems which require either dedicated space or a shared mechanical space. But, grouping these systems along with lavatories and showers makes sense because the plumbing and electrical lines can run between shared walls. In the most basic sense, there is a need for a structure to house all of the services for the shelter.

The question of enclosure comes next. The need for enclosure can vary depending on program. Enclosed sleeping rooms may be desirable for some users. The ability for a family to book a room offers security and privacy. These could be small rooms with a pair of bunk beds, easily able to sleep 4 people. This could also be a revenue generator for the shelters. We see from AirBnb's popularity that many people trust such hospitality models. And renting small rooms for the night, assuming they were affordable, would be quite plausible in this project. They could be minimal in amenities and thus ask a low per night rate to be attractive to budget conscious travelers.

Some program can be semi-enclosed such as a communal seating and table area. A space for cyclists to sit in shade is desirable. A large table could be designed to allow for many individuals to sit at and break-bread together. There could also be areas for smaller tables so a family could sit apart should they desire more privacy. Further, having a covered area to park bicycles could be a real treat to a cyclist. It also makes a statement about cycling infrastructure. What it says is that your bicycle deserves a protected space. Many cyclists will be wary of leaving their only source of transportation unattended, unsecure and uncovered. Many touring cyclists will carry a lock to secure their bike when they aren't riding it. Giving cyclists a safe, covered space to park their bike for the night will bring peace of mind. And if the bike rack incorporated a built in lock per bike, a cyclist may even their heavy lock at home.

When combined as a whole system, the shelter results in a small campus composed of a service building, an enclosed building and a semi-enclosed structure. The structures can then be arranged in relationship to each other and in response to the site. This can result in a positive outdoor space between the buildings. And it will also result in a positive and unique experience for the users. As the users progress through the bicycle route, they will experience something different and unique at each shelter location.

Lastly, with daylight optimization strategies for the roofs and individual buildings, the village layout will follow the same logic and orient buildings to the site and compass. Buildings can be arranged to allow for views, privacy, daylight and framing outdoor space. Buildings can also be used to block prevailing winds.

When combined as a whole system, the shelter results in a small campus composed of a service building, an enclosed building and a semi-enclosed structure. The structures can then be arranged in relationship to each other and in response to the site. This can result in a positive outdoor space between the buildings. And it will also result in a positive and unique experience for the users. As the users progress through the bicycle route, they will experience something different and unique at each shelter location.

Lastly, with daylight optimization strategies for the roofs and individual buildings, the village layout will follow the same logic and orient buildings to the site and compass. Buildings can be arranged to allow for views, privacy, daylight and framing outdoor space. Buildings can also be used to block prevailing winds.

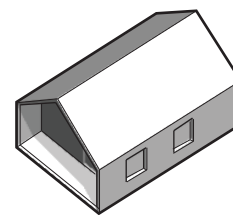

Enclosed Space
Sleeping & Resting
Sitting & Socializing

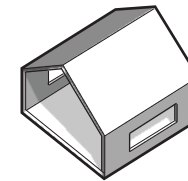

Covered Space
Cooking, Eating
Sitting & Socializing
Bike Parking & Repair

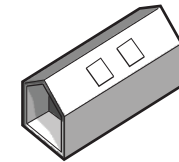

Enclosed Services
Lavatory
Showers
Mechanical Space

Figure 93: 3 Types of structures: enclosed, covered and enclosed services.

Adaptation to Different Site Conditions.

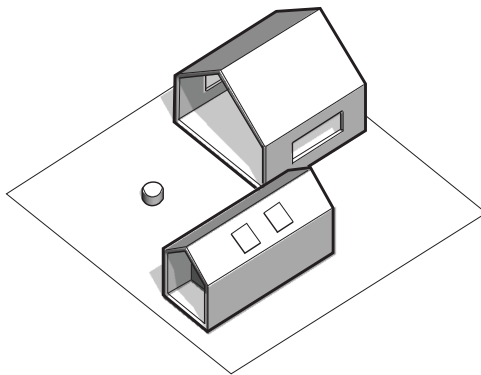

Figure 94: A basic shelter arrangement featuring a service building, covered space and fire pit.

Given this kit of parts, the shelter structures which serve as a vocabulary for the infrastructure, allowing for flexibility based on site and demand. The modularity of the system provides the ability to pick and choose parts components as needed. This will be necessary since no two sites are the same, and the possibility of arrangements between the components is endless.

Examining this to a degree shows the flexibility in the system. In the smallest scale, only a service building and semi-enclosed space would be necessary. This would provide cyclist with refuge, shade, water, a lavatory and a place to pitch a tent.

There is a wide variety of arrangement possibilities of this modular system. A medium size shelter could have enclosed sleeping quarters and covered bike parking. It could be rearranged in a number of ways depending on the site. This medium size arrangement could easily sleep 16 people indoors and offer plenty of room to sleep a dozen outside. The structures can be arranged in a number of ways and even account for sites with sleep slopes.

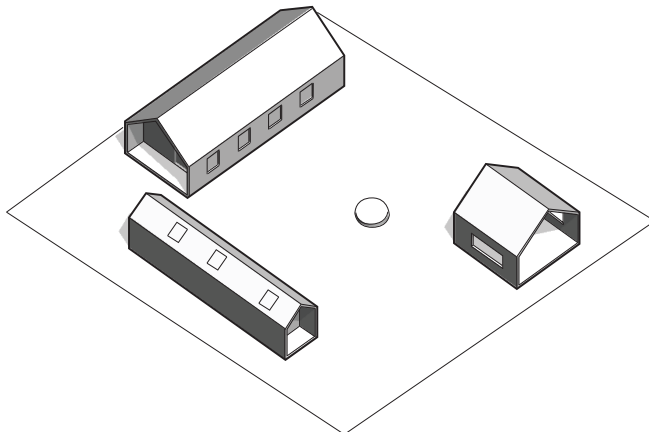

Figure 95: A medium can be arranged to block weather, frame space, connect with views.

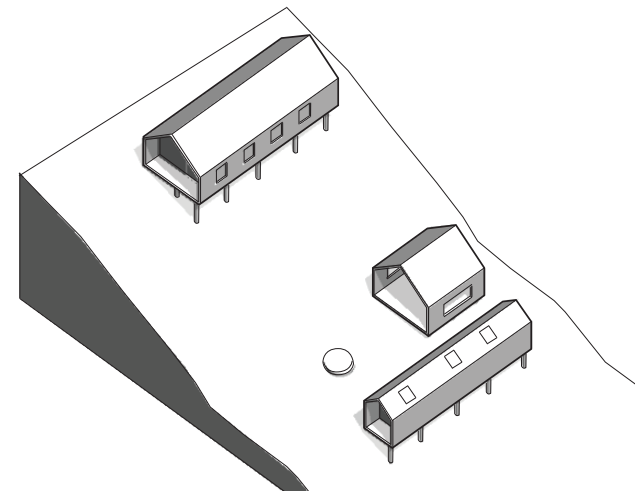

Figure 96: Some sites are more challenging, but the system can adapt accordingly.

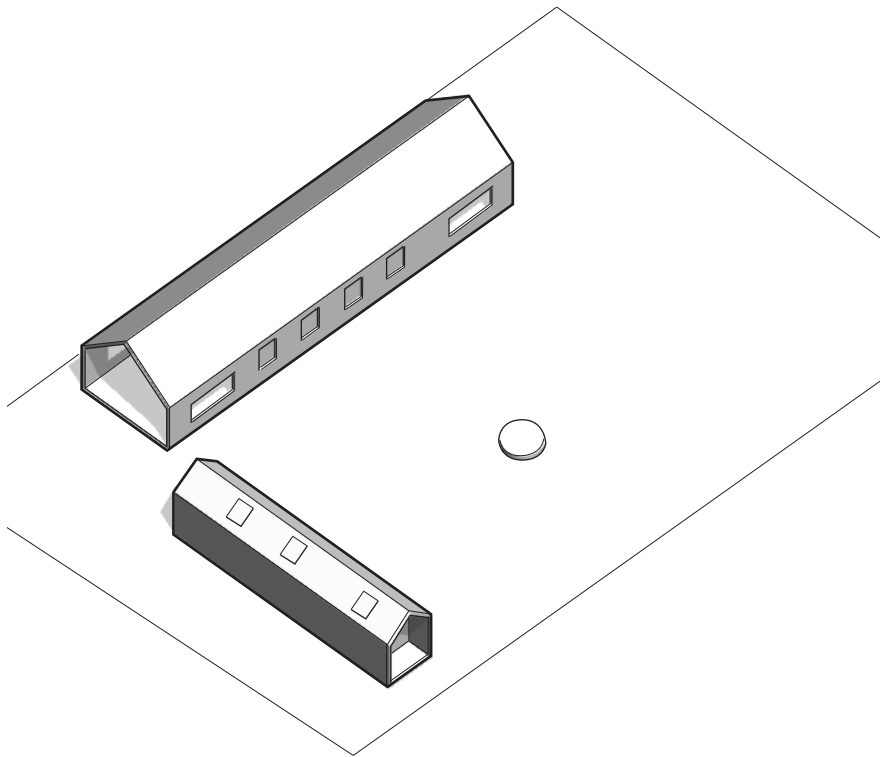

Figure 97: An other arragenemt showing the structures together as a larger building

In the largest capacity, the limitation is not on the system but the site. If there were a demand to sleep 100 cyclists on a single site, then that would be a great problem to have. The system could be added onto to reach a desired capacity. But this would require further investigation. Lets assume that we could sleep 24 individuals comfortably and this would be a busy little camp. Further growth potential would need to be examined based on available resources, demand, potential utilities, etc.

Service Systems and Resource Strategies



Figure 98: Water is a lifeline that every touring cyclist should have access to.

Given the remote nature of some of the shelters, their services need to be able to function despite their location and connection to utilities. There are 4 service systems within the shelters: toilets, water, electricity and monitoring. Each is equally important for users to have access to when they arrive at a shelter and each serves as the lifeline for cyclists. Each of these systems will be discussed further in detail.

The first system which might be one of the simplest systems, is the toilet. Instead of using a septic system which will require a large footprint on site, annual maintenance and higher on-site labor to install, or subjecting users to the unpleasantness of the pit toilet, composting toilets could be used. The Sun-Mar Excel is currently the best selling composting toilet in North America. It is a self-contained design which means the compost is stored within the unit. In vacation usage, one unit can support up to 6 adults. The unit uses AC current to assist in breaking down compost faster than in passive model. The compost within the unit needs to be turned after each use, so educating users on-site through signage will be necessary.⁸⁸ Additional units may be added in the case of higher demand. The resulting compost is periodically removed and can be sold or used in a garden.



Figure 99: The Sun-Mar Excel Self-Contained Composting Toilet

The water system relies on the shelter's roof area to collect rainwater to be turned into drinking water. The more roof area available, the more water can be collected. This water is then treated and stored on-site for use. Given a remote location like Sherman Pass which has less than 17" of rainfall per year, the strategy here would be to have a large cistern on-site to store a summer's worth of water for the cycling season. Even in a dry location such as this, collecting a year's worth of rainwater is possible and it could provide enough water for a number of thirsty cyclists. Once the rainwater has been captured, it is pumped through a series of filters to make it potable before it is set to a large cistern for storage. Plumbing lines within the shelter then feed sinks, and showers. The showers could take advantage of a solar water heater to harvest solar energy and save electricity on heating water.

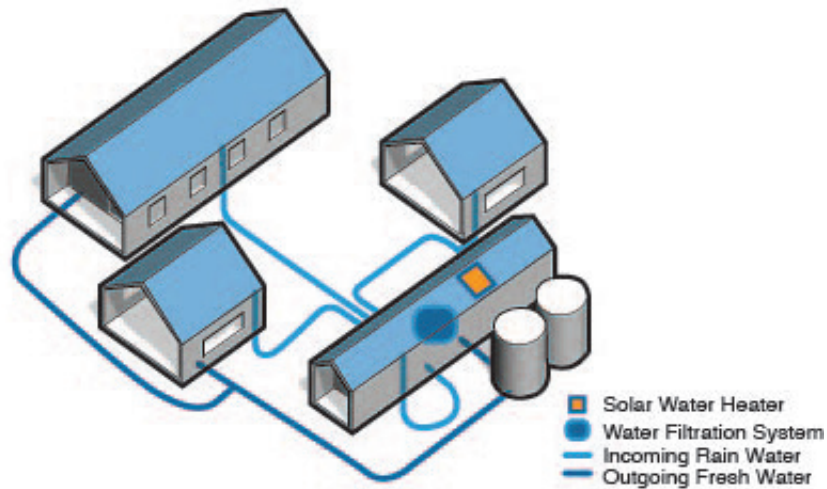

Figure 100: Proposed Water System Diagram.

The electrical system relies on capturing solar energy and transforming it into electricity. Photovoltaic panels are used to perform this task. The panels produce a DC current which is delivered to an array of batteries on-site. Electricity is stored in batteries until there is a demand. Power inverters then transform the DC current to AC current and the current is delivered with the shelters electrical wiring system. Keeping electrical loads low will ensure the system size is kept small and efficient. One of the biggest loads will be the composting toilets which have a heating element within them. This would most likely need a constant source of electricity. Further, if the shelters don't require heating through the winter, or an efficient closed-loop radiant heating system is used, there should still be plenty of electricity for lights, plug loads and other systems.

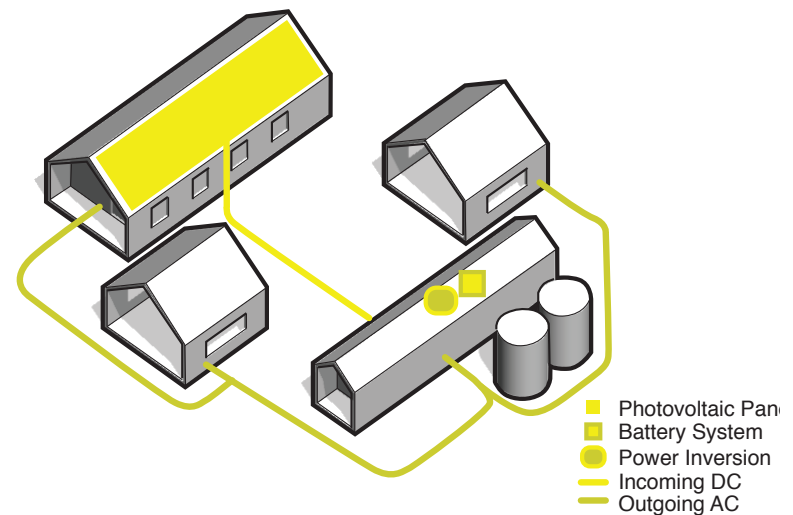

Figure 101: Proposed Electrical System Diagram

The final system is for monitoring the facility. This can have many tasks such as security monitoring, resource levels and occupancy. Unless it was necessary to have a person on location to monitor the facility, ideally the facility could be monitored remotely. All of the technology exists to facilitate this system, and it would be progressive to adapt it in this project. To bring both end users and facility owners peace of mind, security cameras and occupancy sensors could be located throughout the facility. The sensors could also be programmed to turn off lights when a space is vacant. Next, keeping an eye on the other systems and resources in the facility can educate users as well as give owners an indicator of what is available and what is being used. In remote locations, a satellite phone could be used to tap into the system and allow it to be monitored via a web browser. Should a problem arise, or hopefully prior to a problem developing, the system would inform staff accordingly. This could also imply an individual or team could monitor a region of shelters at once, and travel to them when necessary.

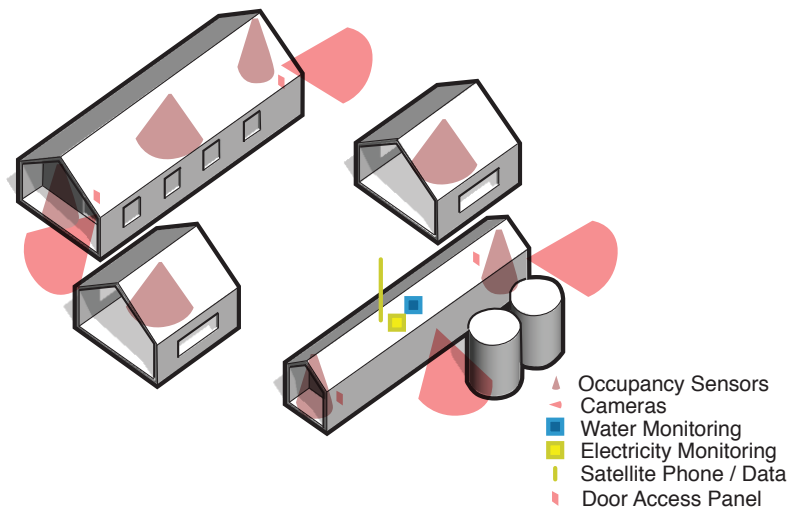
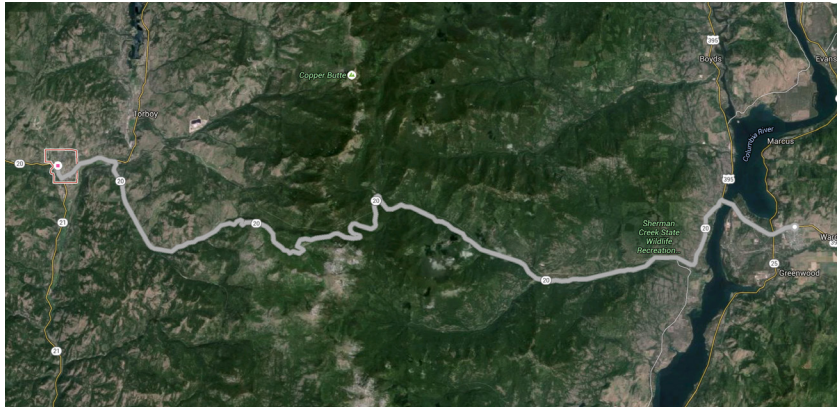

Figure 102: Monitoring System Diagram

The security and monitoring system provides a way for to reserve rooms and to do so remotely. How this might work is through an app and door keypads. For example, a cyclist is traveling east on the NTR in Washington State. They have an idea of how many miles they are capable of riding per day, so they know roughly where they are going to stop each night. Given the proposed system, the cyclist could download an app which corresponds to the shelter infrastructure. The app shows a map where the cyclist is traveling and shelter locations. The cyclist can see availability of accommodations including camping sites and stay rooms. They book a room via the app which charges a credit card on file. The app then gives the cyclist a number for the door keypad they reserved. When the cyclist arrives to the shelter, they enter the number in the door lock and the room is unlocked for them. There is a check out time the next day and should the cyclist stay another day, the system automatically charges their card again should the occupancy sensor show the room is not vacant. What is most exciting about the ability to monitor the facility is the data that the system will collect. We now live in a world where data is king. Many companies see data-mining as essential practice. This system could provide much needed information about touring cyclists and their travels. Demographics, trip length, distance, speed, etc. would all become accessible through the data the system collects. Further, weather data and resource information would also be collected, showing real world figures of water and energy collection and usage. And predictive modeling could be used to improve the system and user experience.



An Example at Sherman Pass

Sherman Pass is the highest mountain pass in Washington State that is maintained year round. The elevation of the pass is 5575'. The pass is in Colville National Forest on Highway 20 between Republic and Kettle Falls.⁸⁹ It is almost 43 miles between these towns and the pass is almost directly centered on the route. However, there is a significant difference in elevation between the towns. The elevation of Republic is 2569',⁹⁰ and Kettle Falls is 1631'.⁹¹ This makes for a challenging day of climbing, especially coming from Kettle Falls as there is an additional 1000' of elevation gain in that direction.

This site represents an extreme case along the case study area in Washington State. Without a shelter here, a cyclist would have to continue for another 20 miles before finding services. A shelter here could be a lifeline for cyclists making their way through the pass.

Figure 103: Republic to Kettle Falls, WA, via Sherman Pass



A Plausible Site

Sherman Pass is a mountainous region that is densely covered in trees. Without clearing trees, the best-case scenario is to find a site that is already relatively clear and mostly flat. An area of about 100' x 100' would be a minimum area to place a shelter. Additionally, it would be ideal if the site was clear enough to not shade the photovoltaic panels as well as featured a nice view or two. There are some creeks that run through the area, which might be a potential source of water. But they are not central enough along the route.

There is a site just east of the pass which appears to be promising. Just off the road by a few hundred feet, is a clearing of about 1500-2000 square feet. An access road to power lines to the west of the site leads cyclists from the road to the site. This gives cyclists some sense of security at the shelter. If the shelter were on the side of the road, any car could pull up and potentially interfere with the cyclist. By pulling the shelter off the road, and possibility relying on a trail to access the shelter, this may deter vehicles from showing up at the shelter uninvited.

Figure 104: A potential shelter location at Sherman Pass

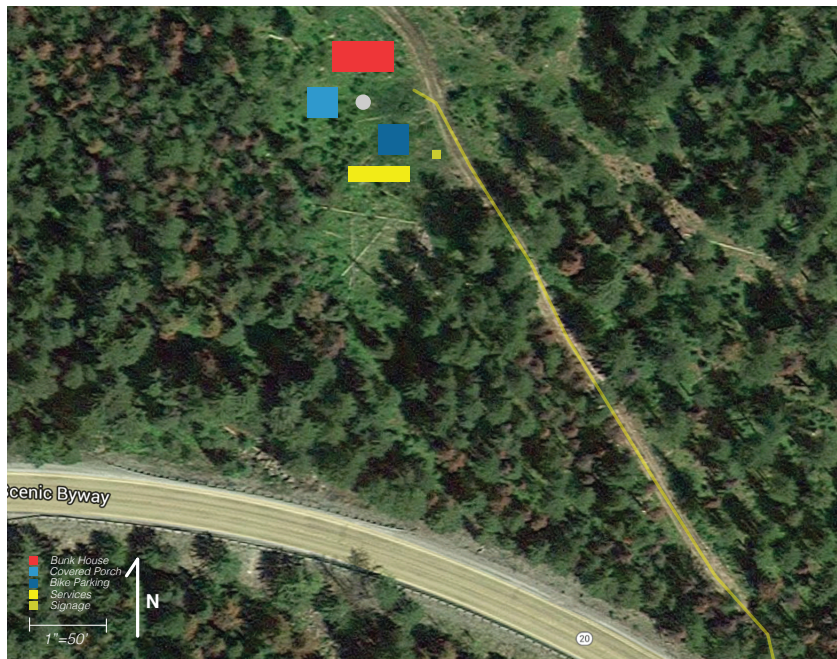

Figure 105: Sherman Pass Shelter Program Diagram

Arrangement of Program

The site is cleared in a way that provides ample room north to south and a fair amount of room east to west. This allows for a rectangular or square layout, using the structures to surround a positive outdoor space at the center of the arrangement.

If we return to the proposed program and group it based on whether it is exposed, semi-enclosed and enclosed we have a basic layout of a building with a covered porch and space out front. But rearranging that program allows the exposed space to be framed. The program can be arranged in a countless number of ways depending on site condition and other factors.

On this site, there is a little bit of room to spread out. The program can be arranged in somewhat of a square shape. This allows users views to the surrounding mountains, plenty of daylight with no impedance on the photovoltaic panels, and creating a framed positive outdoor space at the center of the buildings. Some of the surrounding area can be used for tent camping as well as tables for sitting, eating and socializing. Ultimately, this arrangement allows users to easily make social connections. With a fire pit at the center, and a large farm table, users will have plenty of opportunities to meet fellow travelers.

Building Envelope

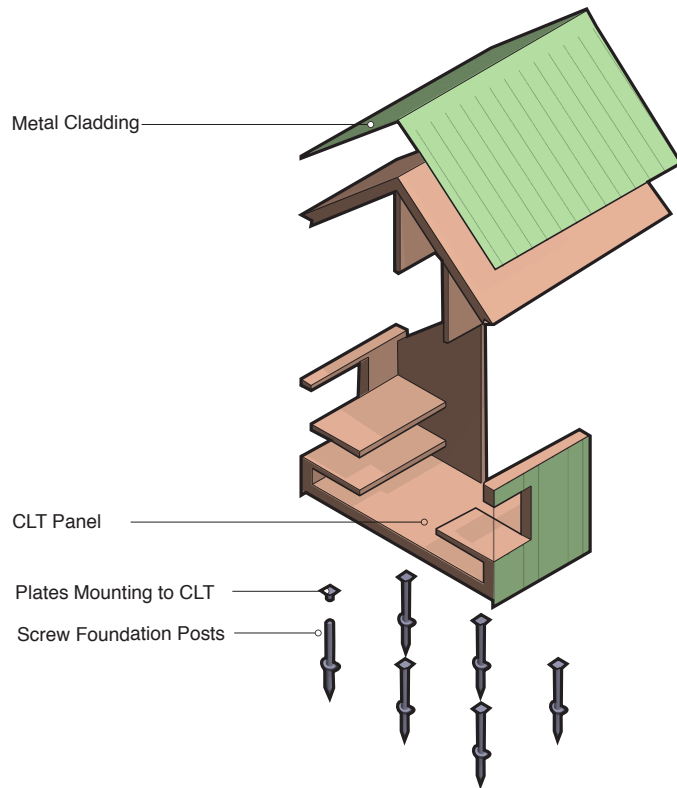

Figure 106: Shelter Building Structure and Envelope Diagram

The primary structure is made of CLT panels. These panels are connected to each other via common details. Some connection types include the use of steel plates between members, long self-tapping screws, and lap joints between members. Lateral stability is provided by perpendicular walls and a series of embedded steel plates.

The structures are then clad in metal siding. Standing seam metal siding is durable and nice in appearance. Siding can cover the roof and turn down the walls to make a durable water-tight envelope. Gutters will be added to collect rainwater. Cladding the building in metal siding will create a rain screen around the building and allow it to last many generations.

In terms of insulation, the semi-enclosed module does not need to be insulated. In terms of the enclosed space, this could go either way. Since the shelters are primarily used in the summer, insulation could be used to keep some of the seasonal heat from penetrating into the structure. The nighttime temperature lows in some areas could also warrant the use of insulation. So, for the sake of longevity, comfort and future flexibility, it would be wise to use insulation on the enclosed structure of the bunk house. The enclosed service building could go either way with insulation. It would seem wise to insulate this building just in case. In order to keep the beautiful exposed wood interior of the CLT panels, insulation could be installed on the outside of the panels, between the metal cladding. On the floors, it could go between the finished floors and the CLT panels. Another note about this area, installing a radiant heating system in the floor assembly would be wise for several reasons. A closed loop-radiant system is efficient in terms of heating and electricity. It also allows the central control system to manage the heat of the building. Lastly, it allows the system to be combined with the insulation layer under the finished floor.



Screw Piles and Foundation Plan

Concrete has a high embodied energy⁸³ which makes it unsustainable and contributes to climate change. Concrete is also a popular building material and commonly used for foundations in combination with steel.⁸⁴ This contradiction leads to a fork in the road. Do you use it, or look for something else? To be as sustainable as possible, the use of concrete in this project could be avoided.

One alternative to a concrete foundation is screw piles. These piles are made of steel, which has less embodied energy than concrete.⁸³ They can also be removed, insulated and require less labor to install as well as no excavation.

An elevated building allows water to pass freely underneath it. This also makes the building more waterproof than a concrete foundation and can withstand flooding.⁸⁵ It can also keep insects and small animals from entering the building. Lastly, it can give the user a different experience. Being elevated feels nice and majestic, even if it is only a few feet off the ground.

Figure 107: Screw piles being installed.

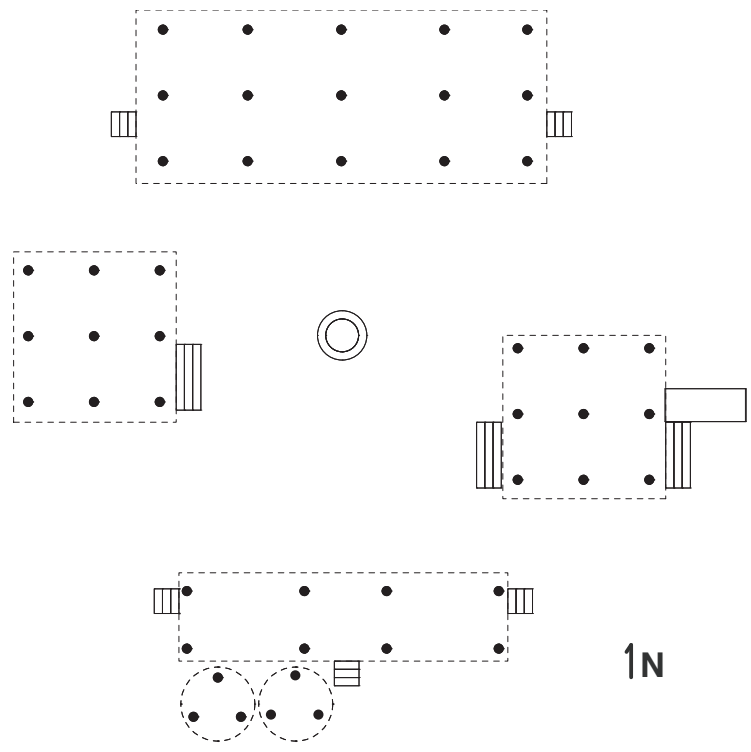

The screws piles act like spot footings, allowing the building to span between piles. Unlike beams, CLT can span in two directions. So a pile arrangement 8'-10' on center should line up well with the 10' structural bays of the CLT module.

Figure 108: Foundation Plan for the Proposed Sherman Pass Shelter.

Floor Plan

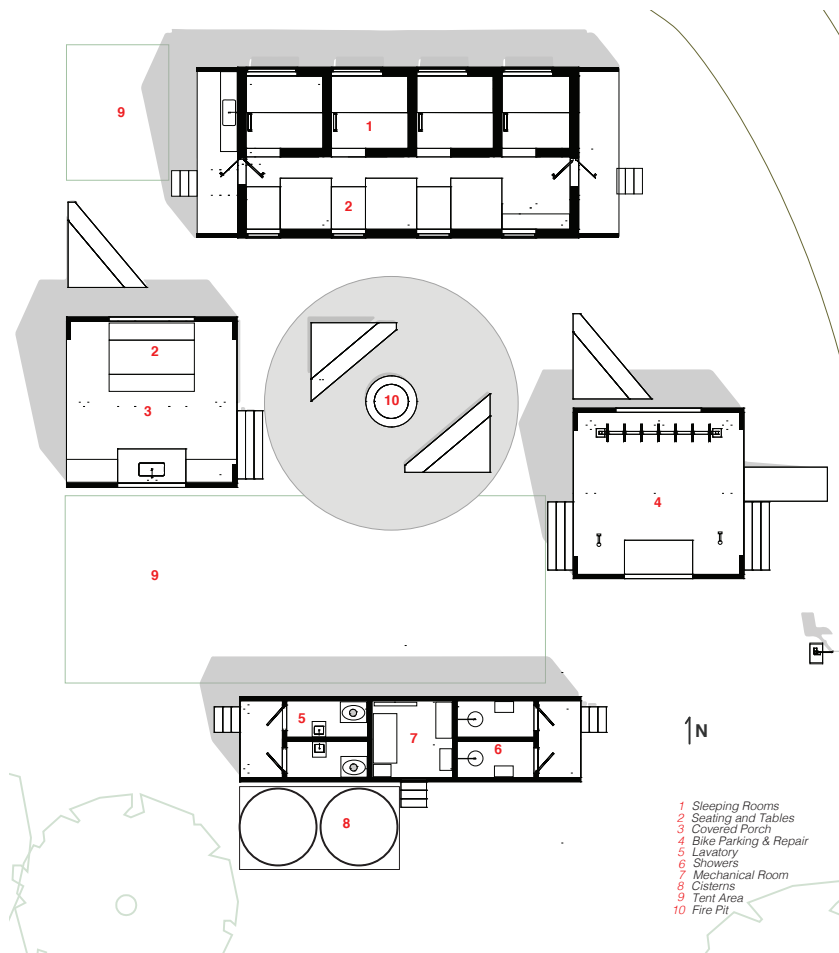

Figure 109: A floor plan for the proposed Sherman Pass shelter

From the floor plan we can see the layout of the shelter. To the north is the enclosed bunk house, which features 4 bunk rooms, 4 sets of tables and seating, and covered decks on both ends of the building. Barn doors open to each stay room. And there is a sink on the back deck for dishes and hand washing. There are window openings on the south façade for day light and the scrap material is turning into the table at the window. The north façade has large windows at each bunk. The material scrap from this is turned into stairs outside the building.

Tent space can be found all throughout the shelter area. Users could sleep in the covered porch areas if the weather is bad. But there is still plenty of space to pitch several tents.

To the west is a covered porch. There is a large table and seating to the north of the structure and a counter and sink to the south. Large openings on the east and west of the structure allow air and light to spill through the building. The openings on the north and south allow for views and day lighting. The scraps from these openings become the table and the bench within the space.

To the east is another covered porch. This one is for covered bicycle parking and repair. There are repair stands to the south as well as a workbench. A large bicycle rack stretches across the northern portion of the building. Scrap material from this opening is turned into a ramp for the bicycles.

On the south end of the shelter is the service building. To the east of the building are two shower rooms with skylights. The west end of the building features two lavatories with composting toilets, sinks and skylights. Central to the building, and accessed from a door on the south face of the building, is a mechanical space. Here is where the system's hardware is stored.

South of the services building are two 5000 gallon cisterns. These are necessary to supply cyclists enough water throughout the summer. Their visibility on-site serves as a reminder that services are limited. As users head to the showers, they can see the cisterns, and maybe this makes them use less water. And to make sure, the showers would use efficient water flow head and be set to a timer.

Last, but not least, is the central fire pit. Central to the space and central in the social interaction of users, the fire pit at the center signifies that this is a camp. This space pushes the notion that being outdoors, feeling the warmth of the fire while starrng at the stars, is how a night in the woods should be spent. And sharing a story with a fellow traveler makes the hot cocoa or beer taste that much better.

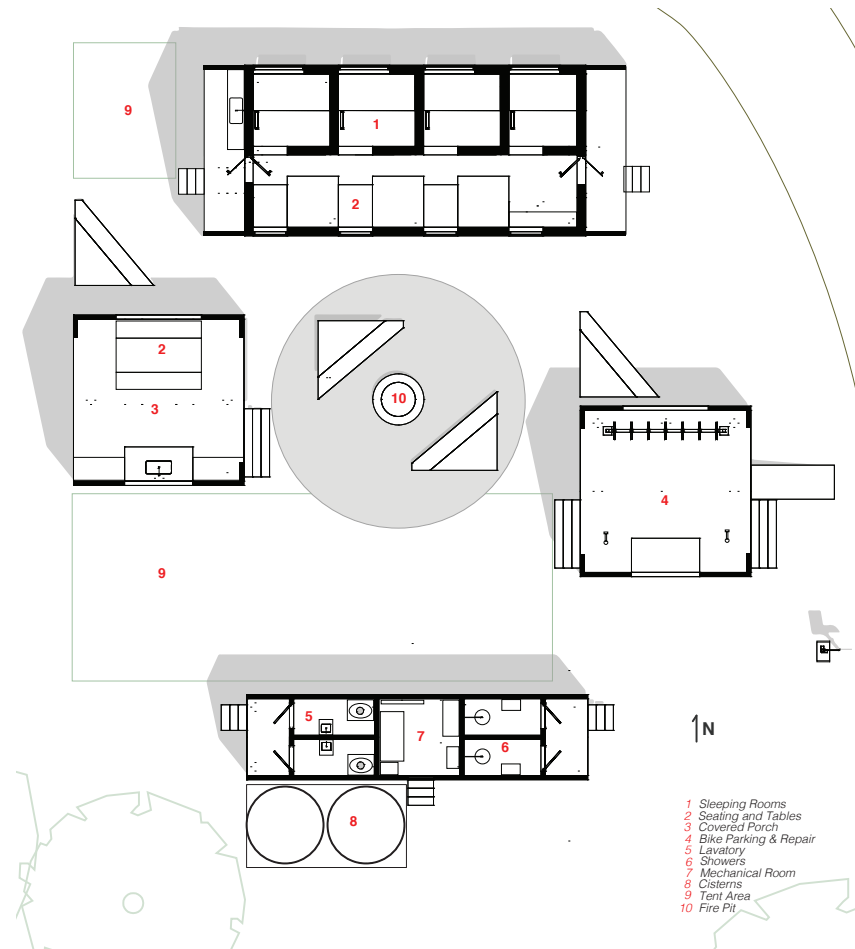

Figure 109: A floor plan for the proposed Sherman Pass shelter

In section, we can see the shelter with some context. The bunkhouse on the left shows the relationship of the bunks to the window and wilderness. It gives users a pleasant rise in the morning as the sun comes in and a view of mountains in the distance greet them. On the south of the bunkhouse, a family can eat breakfast early in the morning before heading out for the day's ride.

Section

In the daytime, the central fire pit area can still be used for sitting, eating and general relaxation. In the background is the covered porch for bicycles. Here individuals can work on their bicycles and prep for departure.

To the south, or right, is the service building and cisterns. This building is half as wide as the others, primarily because it does not need to be bigger. By making its depth 10', it switches the structural width in the opposite direction, allowing the building to be 40' long and a single CLT panel.

Also visible are the screw pile foundations. A series of them would be used throughout the shelter. The cisterns could sit on an elevated platform before transferring the load to the screw piles and then the ground.



Figure 110: A section view of the proposed shelter at Sherman Pass.

Lighting Plan

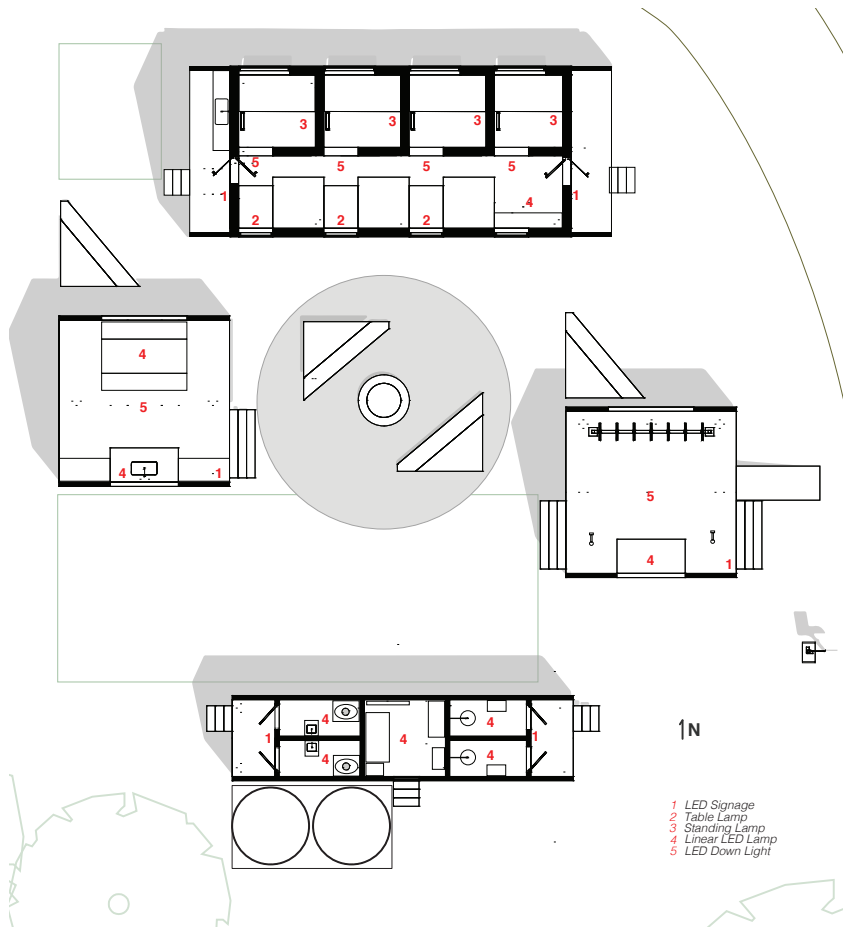

Figure 111. A proposed lighting plan at the Sherman Pass shelter.

In terms of lighting the shelter, a simple yet high-tech lighting plan is desirable. In the woods, it is much darker at night than in the city. But instead of over lighting the space, being sparse with lighting can be highly effective.

LED lights should be used through the project to be energy efficient. This type of lamp will also need less maintenance than traditional lighting types. Motion sensors throughout the space can be used to detect vacancy and turn off or dim when the space is vacant. Motion sensors can also help users navigate at night as they walk through unfamiliar surroundings.

Simple yet durable LED down lights could be specified in strategic locations to create focused light for a given task. These could be narrow in terms of their light beam projection. This could keep light pollution to a minimum and not attract as many insects.

Linear lights could be used in a few locations such as above counters and workbenches. And lamps within the enclosed space could be modestly specified. These could be LED table lights and standing lamps. This gives users a bit of freedom about which lights are on and where they could be moved about within the space.



Figure 112: A Rendering of the proposed signage.



Figure 113: A Rendering of the proposed shelter as users gather around the fire pit.



Figure 114: A Rendering of the proposed shelter as users gather around the fire pit.



Figure 115: A photo of a model showing the tectonics of the bunkhouse structure.

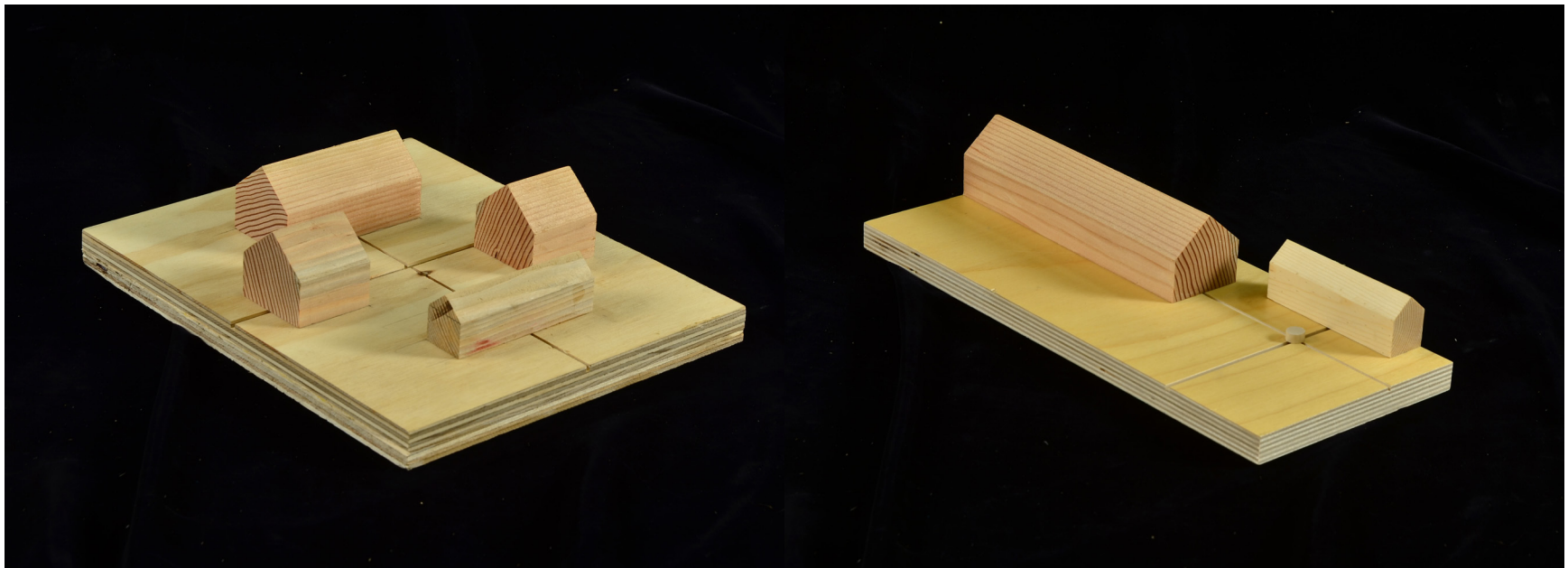

Figure 116: A Photo of a model of the proposed Sherman Pass shelter.

Figure 117: A photo of an alternative shelter arrangement.

Chapter 11:

Conclusion

In conclusion, this project shows ways in which we could be innovative in infrastructure, bicycle tourism and offering services to cyclists. With a bit of forward thinking and a desire to make a difference, Washington State could become the eco-tourism center of America. The ingredients are all there for this project to success. Washington State has the highest bicycle industry in the US. We have the most bicycle friendly state and the best bicycle advocacy. The state is covered with a dense network of established bicycle routes. And we have a geographically rich landscape that the world wants to see. Capitalizing on this recipe could bring only good to the state. From rural economic development, to tax revenue for the state, bicycle tourism is a viable economy that Washington State has yet to explore.

From a social perspective, this proposal offers cyclists an identity they have never experienced in the US. Countries like Denmark have proven that investing in cycling infrastructure and thus bicycling for transportation, can save the country money and improve the health of its citizens. The US has a long-standing history with bicycles. But a century long battle with the automobile has been like a story of David and Goliath. Although in this case David hasn't won, yet. Embracing bicycles and bicycle tourism would not eliminate the automobile; it would only give bicycles another chance to succeed. The history of the bicycle shows innovation and resilience. People are drawn to bicycles because they believe in them and see their potential. And ultimately, bikes outsell cars because they are way more fun. Bicycles offer a great return on investment.

From an architectural lens, I believe the project has potential. It is not about glamor and flash. That is not what the project calls for. A simple yet elegant design is appropriate for this project. And most importantly, the project requires a solution that is flexible and adaptable. If 15 shelters are needed in Washington State, then the whole of the Northern Tier Route would need 141 shelters. Deployment at this rate requires a system that can allow for change as well as rapid construction. In using prefabricated construction and designing a simple structural module, it is plausible that this method could be used throughout the proposed infrastructure of this project.

The whole is greater than the sum of its parts. The infrastructure proposed in this project, consisting of shelters, signage and art would create an identity that is immeasurable. When the world finds out about it, people will come from all over the world to experience it. And they will not stop coming as long as it stands. The potential for this is so great because it could be scaled up and down across routes and locations throughout the country. And it could lead to a second coming in terms of the US being innovative in the form of personal transportation.

Chapter 12:

Short Story

John gazed out the window at the majestic mountains surrounding him. From a distance, the trees seemed to disappear into the jagged forms. Layer after layer of mountains faded into the distance. He could hear the occasional car on the highway. As the rain continued to downpour, he questioned whether he was putting his kids in danger. He took a deep breath and exhaled slowly, taking one last look at the mountains to the east.

“Well, I don’t think the rain’s going to let up anytime soon,” John announced to the room. “We’ll probably have to stay here another night and hope that it clears by tomorrow.”

Margaret ruffled through a pannier before pulling out a large half empty stuff sack. She opened it and recovered some crackers and cheese. “I think that’s best,” she replied as she arranged the crackers and cheese on a folding plate and placed it on the table. “We’re going to need more food. Is it about two days until we reach Winthrop?”

“I think we can manage it in two days,” John said as he grabbed some cheese off the plate. “Do you remember that couple from yesterday? They said there’s a decent store in Newwhalem. That’s just up the road.” He unfolded a map and laid it on the table. “There’s also a visitor’s center there too. It could be interesting.”

“Pappa, do we have to ride in the rain?” Elliott asked.

Touring the North Cascades

“Not today Elliott. I think this storm will pass later today,” John told him. “We should be ok to ride tomorrow.” He examined the map as he ate more cheese. Although it was raining and overcast, the room was well lit. The room’s electric lights were off but no one noticed. John could easily make out the contour lines on the map. He looked closely at the elevation chart at the bottom of the map. After calculating the elevation gain in his head, he suddenly looked up Margaret. “Tomorrow’s going to be a tough day. It’s over 5000 feet of elevation gain.”

“Well, we can handle it. I think the kids will be fine. We can stop as often as they want,” Margaret said calmly as she glanced at the kids sitting at the table. “Will you take a look at my rear derailleur sometime today? It’s still shifting weird.” She went looking in the pannier again and pulled out another stuff sack.

“Sure,” John said as he looked at the repair station in the corner of the room. “That shouldn’t take too long.” He got up and walked across the room to examine the tool bench. “It looks like they have a full set of tools.”

Margaret took a sweater out of the bag and held it up to examine it. She walked over to Elliott and put it on him. His attention never broke from the cartoon he was watching on a tablet. She then took the empty plate to the sink and began to wash it.

“Mom, I’m still hungry,” Kristin said with a bit of a whine in her voice.

Margaret continued to wash the dishes as she replied, “there’s some dried pineapple and apricot in the food bag, honey. You can help yourself.” She looked out the window at the rain as she dried her hands. “John, can you get some groceries from that store? We should start thinking about dinner. I can entertain the kids for a bit.”

“I saw they have some board games,” he stated as he pointed to a shelf. He walked over and looked closely at the games. “Cards, Uno, Skipbo, checkers, chess, Monopoly, and it looks like dominos. That should keep us busy through the night.” He took the Monopoly box from the shelf and walked back over to the table. “Do you guys want to play Monopoly?”

“Yeah!” yelled Elliott looking up from the screen.

“I want to be the train,” proclaimed Kristen.

“Did I tell you there’s a old train in Newhalen,” John said to her.

“Cool! Can we go see it daddy?” Kristen asked.

“If the rain clears, we’ll be passing by it in the morning. We can stop to see it then.” John began dressing for the rain. He put on he waterproof jacket, hat, helmet and gloves. “Is there anything you want from the store?” He asked Margaret.

“Whatever is healthy,” she replied as she handed out the Monopoly money to the kids. “Two days worth.”

John opened the door and stepped outside. Some cool air came in, but it felt refreshing. The smell of rain filled the room. He stared off into the distance and examined the rain. “It looks like it’s letting up a little,” he told her. “Well I should be back within the hour. Can you pass me my phone? There might be reception or wifi there.”

Margaret unplugged the cellphone from the charger and walked it over to him. “Ride safe,” she told him before giving him a kiss.

John grabbed his bike from the covered bike rack and walked it down the gravel path toward the road. Margaret watched him from the covered porch until he was out of view. She closed the door and returned to the table.

The next morning the family woke early to the warm glow of sunrays coming through the windows and lighting the space. The photovoltaic panels on the roof were rapidly producing electricity for the shelter and the solar shower was plenty hot and appreciated. John warmed water in an electric kettle to make coffee and oatmeal. He also toasted some bread over an electric hot plate and soon enough they sat around the table for breakfast. They sat and ate quietly as the warm morning sun illuminated them. The kids ate quickly and went to play out front as Margret finished the dishes and John packed their belongings into the panniers.

“Do you guys need to use the restroom before we leave?” she called from the doorway.

“Yes, please,” Kristin answered as she ran toward her mother.

“I went earlier,” Elliott replied as he threw a rock into the open field.

“Well, come put your helmet on, we’re going to leave soon,” Margret told him as she walked Kristin to the outhouse. She turned to Kristin and asked, “Do you remember how to use a composting toilet?”

“Yes, I used it twice yesterday,” she replied and then entered the outhouse. After a few minutes she exited and walked back to the front porch.

“Go inside and wash your hands, honey. And then put your helmet on, we are about to leave.

John had the bikes loaded and ready. The family toured on two tandem bikes that were custom made for them and came complete with their names on them. On the top tube of one bike was hand painted script that read “Margret” and “Elliott” and the other bike “John” and “Kristin.” The bikes were works of art, locally made with fine craftsmanship. They were equipped for long distance touring included front and rear racks for their many panniers and about a half dozen water bottle cages on each bike. Before they had children, they travelled on a tandem together, but they had even more gear to carry then. Before major touring routes had shelters, the couple used to carry a tent, gas stove, fuel, kitchen items, and more. And now, even with the kids, they traveled lighter then they ever did.

“Is everyone ready?” John asked them as he did a visual inspection. With their helmets on tight they mounted the bikes. At just past 7am, they turned onto the road and they were off. With the sun on your faces, they headed east further into the North Cascade Mountains.

Within a short period of time, they arrived in Newhalem. They stopped to see the steam powered train engine and took pictures next to it. The kids rang the bell on the train and soon enough they were off. They soon stopped again at the Gorge Powerhouse and John snapped a few photos before they were off again.

The grade in the road increased and suddenly they faced some steep hills. But the scenery was remarkable and they stopped often to take photos. They stopped when they saw Diablo Dam and again at Ross Dam, taking photos of each. But soon the mountain lakes disappeared and they were deep in the mountain range. The kids were quiet and without complaints despite the challenging terrain. John provided distractions by naming every mountain and feature they saw. Margret sang songs to them and they played games like “I spy” to past the time. They stopped often to snack and drink water. After several hours of travel, they arrived at a bicycle rest stop and decided to have lunch. Margret made everyone peanut butter and jelly sandwiches, and they ended up having two a piece.

They found refuge from the long climb in the rest stop. It was a covered space with a place to sit out of the sun and rest. There was a composting toilet that they each used. A waterspout allowed them to refill their empty water bottles. They ate and drank all they could before getting organized to leave. Although it was only an hour spent there, it was an hour out of the hot sun, and they found it refreshing. Morale was restored and they were ready for more. Or at least the kids were energetic.

The temperature was rising and the family had shed their cold weather clothes. They had entered the hardest part of the ride now. For the next twenty miles they averaged about 4 miles per hour and climbed over 2000 more feet in addition to the morning's climb. When they were feeling defeated and resting for five minutes didn't help, they would take turns motivating the others into continuing. Even Elliott managed to heighten spirits with talk of s'mores. They each took turns saying how many they would eat when they finally arrive at the next shelter.

By the time they got to Rainy Pass it was late in the afternoon. The sun was beating down and air temperature was in the 90s. They rested for longer than usual and ate whatever snacks they had. Thankfully, the waterspouts were working and they were able refill their water bottles yet again. After about thirty minutes they motivated each other to move forward. Over the next five miles they would climb another 1000 feet. Although it was tough, they did it as a family and the experience would be unforgettable.

When they arrived at Washington Pass, there was a great sigh of relief. They cheered and rang the bike bells continuously for 5 minutes. Then they lay in the grass in the rest area for as long as they could. Kristin broke the silence when she asked her mom where they were staying for the night.

"Good question, honey. John?" she turned to her husband with an assuming look.

"I'll go find it, it should be close by," he said as he got up from the cool grass. He walked around the parking lot for a few minutes before returning. "Do you see that electric car over there?" he pointed across the lot at a small white vehicle. "That's an electric car charging station. Next to that is the sign denoting the shelter. Let's gather our stuff and go over there. Hopefully the solar shower is hot!"

They walked past the sign and down a narrow gravel path that lead into the forest. Soon they arrived at the shelter and parked their bikes at the rack in front. There was another bike parked there already which was covered in tourist stickers from around the world. They left their bikes and headed up the front steps and knocked on the door. They were greeted by a man in his late forties with a strong build and short hair.

"Hello, welcome!" the man said in a German accent. "Come in, come in," he said enthusiastically.

“Hi, thanks,” John said as he walked his family into the cabin. This structure was a bit bigger than the others they had seen. It had a large open space which consisted of a kitchenette, dining table, a seating area complete with a fireplace, a bike repair area and hallways that led to stay rooms. The greatest feature was the large southeast facing windows that led onto a covered porch at the edge of which was a fire pit with seating around it. The whole family walked out onto the porch for a better view. The shelter was built close to a cliff that overlooked the eastern side of the pass, down a thousand feet. The view looked straight onto Silver Star Mountain and Kangaroo Ridge, but many others could be seen as well.

“I’m Sven, by the way,” the German said as he stuck out his hand to John.

“Hi, I’m John, this is my wife Margret and our kids Kristin and Elliott,” John said as he shook his hand and then pointed to his family.

“Hi,” Margret said as she shook his hand. “Where are you from?”

“I’m from Germany,” he replied.

“Great,” John said. “Where are you touring from?”

“Well, I started in South America, Argentina. I came up north through Mexico. Then I traveled through New Mexico, Colorado, Wyoming, Montana, Idaho and now Washington. I have about two weeks before my visa expires, so I’m hoping to go to the San Juan Islands before that. Then I go to Canada for a while before winter and return home,” Sven said as he refilled his water bottle in the sink.

“That’s wonderful!” said Margret.

Kristin came up to her and interrupted, “Mom, can I have something to eat?”

“Sure, honey. Have a seat with your brother and I’ll bring you something. Are you hungry Elliott?”

Elliott was already deep in concentration on his tablet but managed to stay, “Yes, please,” without breaking from the screen.

Margret went searching in the pannier and pulled about a half empty stuff sack. She then pulled some items out of sack and turned to everyone to ask, “Does anyone else want something to snack on? Sven, would you like something to eat?”

“No, thank you,” he replied. “Also, I took one of the rooms already, but there is one more on this side of the cabin.” He gestured down the hall. “I’ll let you get settled in.”

“Thanks,” John told him. He stared out the window for a while. The space was quite, well lit and had an epic view. The ceiling was higher than average and made the small cabin feel large. John was worn out but felt grateful to have a nice place to stay after such a long day. He stared at the view for a moment longer before walking down the hall to the room. Inside, there were two beds and furniture built into the walls. It wasn’t much, but it was going to serve his family just fine. He put their bags on the built in table in the corner and then opened the shades on the windows. Light filled the room. He thought about taking a nap, but he decided against it. He was relieved that they made it. They had a few hiccups along the way, but they made it just fine. He was proud of his family and relieved that the worst was past

them. He thought about how great it would feel to ride downhill for the next few days.

After the family ate dinner they gravitated outside on the back deck that overlooked the pass and the mountains. The sky was still bright but the sun was going to set soon. The temperature was slowly falling and as soon as the sun set it would be cold. John was working on getting a fire started and Margret had the ingredients ready for s'mores. The kids sat patiently on the built in seating on the deck and watched their father build the fire.

"Should we invite Sven to join us?" John asked Margret.

"Sure, I'll go get him," she said and went inside to look for him. Soon she returned with him and they sat around the fire pit.

"What a great view we have. Thank you for inviting me to join you," he said.

"No problem," John told him. "What could make this view better than a fire?"

"Very true," Sven agreed.

Soon the fire was going and required little maintenance. John sat next to Margret who was handing sticks with marshmallows on their ends to the kids. Then she prepared one for John and herself. She asked Sven if he wanted one and he enthusiastically agreed. They had an extra stick just in case and she handled it to him. The five of them sat with their sticks, roasted marshmallows in the warm fire.

"So where are you traveling to?" Sven asked them.

"We're going across the country!" Elliott said proudly. His marshmallow was a bit charred at the end of the stick.

"We are biking to Maine," Kristin told him.

"That's wonderful! What a great adventure," he told the kids.

"We are crossing the country on the Northern Tier Route from Washington to Maine," John explained. "Margret and I crossed the country years ago. But this is our first major tour with the kids. When we toured in the past, the shelters weren't in place along this route, and the experience was quite different. Now, we felt more comfortable making the journey with the kids."

"That's wonderful," Sven said as he blew the fire off of his marshmallow. "The shelters are a real luxury. I've toured in many parts of the world, and touring in the U.S. is now my favorite. The shelters are very nice. Not even in Europe do they have them!"

John examined his perfectly tan marshmallow and decided to put it back in the fire a bit longer. "Yes, we're spoiled now with these shelters. It makes touring really easy and comfortable. And I hear they're so successful that many more routes are scheduled to get them."

"It's so nice not to have to bring all that extra gear," Margret added in. "And touring with the kids has never been easier."

"Yes, I have seen more families traveling together here than in other places," Sven replied. "So how long are you traveling for?"

“We hope to make the trip in about 10 weeks.” Margret said as she helped Elliott assemble his s’more. “We’re both teachers, so we have to get back to teaching in September.”

“That’s wonderful!” Sven said enthusiastically.

They each concentrated on assembling and eating their s’mores. The treat tasted so much sweeter after such a grueling day and the view further enticed them. The sun illuminated the surrounding mountaintops and was close to setting. The fire crackled in the steel fire pit. There was a soothing breeze that brought the freshest air any of them had inhaled. From their vantage point, they could see an occasional spec of color below, which barely resembled a car driving through the pass. They sat and took it all in, and the extensive climb seemed like it was long in their past.

By the time it was dark, they had eaten one too many s’mores, but no one felt guilty about it. Margret took the kids to wash up before bedtime. She too was exhausted and retired early. John and Sven kept the fire alive late into the night, swapping stories of touring and talking bikes. The stars were glowing in the night sky and they were awestruck by how many were visible. Eventually, they were too tired to talk any longer and they decided to call it a night. John poured water over the remaining amber coals and steam rose to the sky. It was dead quite except for an occasional owl calling into the night. They told each other good night before walking to their respective rooms for a well-deserved slumber.

The family woke to the first beams of sunlight through the window. They meet in the kitchen for breakfast. Sven was preparing himself for departure. John and Sven spoke about their plans for the coming days and then exchanged contact information. The family stood on the front porch to wave him goodbye and watch him pedal out of view.

After they ate and washed up, they prepared themselves for departure. They gathered their belongings and neatly organized them into their panniers. They cleaned the cabin leaving it tidier than when they arrived. They looked one last time to the view overlooking the valley. Then they placed their helmets on and refilled their water bottles. Locking the door behind them, they were off.

Back on the North Cascades Highway, the road became a steep descent into the valley. They rode downhill cautiously and stopped frequently to let the brakes cool off and took every opportunity to snap photos of the vast mountains around them. To the side of the road was a cliff that dropped hundreds of feet and the kids were scared to look down. The steep road continued for many miles before it leveled to a tolerable slope. But for about 20 miles they had a swift pace as they descended thousands of feet into the Methow Valley. There were no services in the area, except they did see one sign for a bicycle rest stop in the opposite direction. Luckily, they were happily coasting downhill passing beautiful scenery along the way.

In the Methow Valley the road become relatively flat and they were pedaling at a steady pace. They caught occasional glimpses of the Methow River from the road. Drivers in the area were courteous and gave them extra room. When they passed Mazama they stopped by the Barn Bicycle Camping location. They spoke to a couple from Arizona who was touring the country for a year. They shared a few stories before the kids proclaimed the need for food. They wished each other safe travels and the family was back on the road.

It was around lunchtime when they arrived in Winthrop. They were pleasantly surprised by the rustic and western appearance of the town. It was like it was preserved in a time capsule, safe from modernity. They found a quiet restaurant to stop for lunch. They parked their bikes in the bike rack out front and headed in. They ordered sandwiches with french-fries. Margaret ordered a few large salads for them to share and John ordered an espresso for himself. It had been almost a week since they got to sit down for a warm prepared meal and they took it all in. They ate all the food that was ordered and they kids seems full and content. They paid the check and left a generous tip for the friendly waitress.

Outside the temperature was in the 90s and sunny. The air was dry and there were no clouds in sight. They didn't reach the bike rack before Elliott called out, "Ice cream! Mom can we get ice cream?" He pointed to a sign across the street.

"Yeah, mom, can we get ice cream?" John called out, with a smile on his face.

"Sure," Margret said. "But we're going to have a light dinner."

They walked over to the café that advertised locally made ice cream. They each got a sugar cone with a scoop of ice cream and headed back outside. Sitting on a bench along the street edge, in the warm sun, and the family ate the cold refreshing treat before it could melt. The sun felt warm and pleasant on their faces. The kids played in a field close by after they finished their ice cream. John whipped out his cell phone to check on the location of the nearby shelter. Margret walked to the general store to get groceries. Within 15 minutes she returned and called the kids over. John had the directions they needed and they got back on the bikes to leave.

The shelter was just down the road from the town's main strip. They turned off the road and headed into the trees. The cabin was small, rustic but charming and was located next to the Methow River. It had enough privacy to be comfortable. John examined the various features of the structure, from the photovoltaic panels to the composting toilet in the outhouse. The kids dropped their helmets and ran through the trees. Margret sat on the back deck and watched the water flow past her. John typed in a code into the keypad by the door and unlocked the cabin. One by one he brought their bags inside. He opened the shades and let light fill the cabin and then opened a few windows. The cabin had a small footprint but the high ceiling that made it feel larger

than it was. The open loft had a steep set of stairs leading up to it, but he felt comfortable letting the kids climb it to sleep there. After plugging in their devices to charge next to the kitchen counter, he grabbed his camera and headed outside.

He joined his wife on the deck and snapped a few photos of her as she stared at the view. They shared their thoughts about the beauty of the location and the coziness of the cabin. Margret recommended they take a day off and stay an extra night. John agreed and said the calendar showed it was available the next night. He took photos of the kids playing in the woods as the came into view. John and Margret sat by the river and lost track of time. Sunlight came in through the trees and reflected off the water's surface. They could hear an occasional car passing on the road. For a moment, time stood still and they forgot about the rest of the world. It felt like home, even though they were hundreds of miles from it.

Works Cited

1. History Magazine. (n.d.). Retrieved June 03, 2016, from <http://www.history-magazine.com/bicycles.html>
2. America on the Move | The Development of the Bicycle. (n.d.). Retrieved June 03, 2016, from http://amhistory.si.edu/onthemove/themes/story_69_2.html
3. Bicycle History (& Human Powered Vehicle History). (n.d.). Retrieved June 03, 2016, from <http://www.ibike.org/library/history-timeline.htm>
4. Lessing, T. H. (2014). A Beautifully Illustrated History of Bicycle Design. Retrieved June 03, 2016, from http://www.slate.com/blogs/the_eye/2014/07/22/bicycle_design_an_illustrated_history_by_tony_hadland_and_hans_erhard_lessing.html
5. Making the Modern World - Icons Of Invention - Technology - 1880-1939. (n.d.). Retrieved June 03, 2016, from http://www.makingthemodernworld.org.uk/icons_of_invention/technology/1880-1939/IC.025/
6. History. (n.d.). Retrieved June 03, 2016, from <http://www.maxionwheels.com/en/about-us/history.aspx>
7. GM rediscovers the value of planned obsolescence. (n.d.). Retrieved June 03, 2016, from <http://www.autonews.com/article/20120213/BLOG06/120219952/gm-rediscovers-the-value-of-planned-obsolescence>
8. Bicycle Transportation History, Past, Present and Future. (n.d.). Retrieved June 03, 2016, from <http://www.lafn.org/~dave/trans/bicycle/bicycle.html#s1>
9. Wright Brothers Aeroplane Company/Information Desk/Just the Facts/Wright Bicycles. (n.d.). Retrieved June 03, 2016, from http://www.wright-brothers.org/Information_Desk/Just_the_Facts/Bicycles/Wright_Bicycles.htm
10. The Editors of Encyclopædia Britannica (2016). Pneumatic tire | transportation. In Encyclopædia Britannica. Retrieved from <http://www.britannica.com/technology/pneumatic-tire>
11. History.com (2010). Model T - facts & summary. history.com. Retrieved from <http://www.history.com/topics/model-t>
12. History.com (2009). Henry Ford test-drives his “Quadricycle.” history.com. Retrieved from <http://www.history.com/this-day-in-history/henry-ford-test-drives-his-quadricycle>
13. Web, C. (2015, October 24). The birth of Ford motor company - Henry Ford heritage association. Retrieved June 3, 2016, from Henry Ford Heritage Association, <http://hfha.org/the-ford-story/the-birth-of-ford-motor-company/>
14. The gospel of good roads: A letter to the American farmer: Isaac B. Potter , league of American Wheelmen national committee on improvement of the highways: Free Download & streaming: Internet archive. (1948). Retrieved June 3, 2016, from <https://archive.org/details/gospelgoodroads00highgoog>
15. The Editors of Encyclopædia Britannica (2015). Good roads movement | United States history. In Encyclopædia Britannica. Retrieved from <http://www.britannica.com/topic/Good-Roads-movement>
16. History of the US highway system. Retrieved June 3, 2016, from <http://www.gbcnet.com/ushighways/history.html>
17. The History of the Interstate System. Retrieved June 3, 2016, from <https://www.fhwa.dot.gov/highwayhistory/interstate.cfm>
18. Interstate frequently asked questions - 50th anniversary - interstate system - highway history - federal highway administration. (2015, November 18). Retrieved June 3, 2016, from <http://www.fhwa.dot.gov/interstate/faq.cfm>
19. US v. National City Lines. Retrieved June 3, 2016, from <https://casetext.com/case/united-states-v-national-city-lines-4>
20. The great transportation conspiracy (2002). The great transportation conspiracy. Retrieved June 3, 2016, from <http://www.brooklynrail.net/NationalCityLinesConspiracy.html>

21. Henricks, M. (2010, September 3). The GM trolley conspiracy: What really happened. Retrieved June 3, 2016, from <http://www.cbsnews.com/news/the-gm-trolley-conspiracy-what-really-happened/>
22. History.com (2009). Yom Kippur war - facts & summary. history.com. Retrieved from <http://www.history.com/topics/yom-kippur-war>
23. The early '70s: OPEC, AAA, SPR and corinthian leather « the water cooler. (2011). Retrieved June 3, 2016, from <http://www.summitenergy.com/blog/2011/06/the-early-70s-opec-aaa-spr-and-corinthian-leather/>
24. Franken, O., & Corbis. Oil shock of 1973–74 - A detailed essay on an important event in the history of the federal reserve. Retrieved June 3, 2016, from <http://www.federalreservehistory.org/Events/DetailView/36>
25. The Schwinn Stingray. (1981). Retrieved June 3, 2016, from <http://schwinn-cruisers.com/bikes/stingray/>
26. Brooks, & profile, V. my complete. (2014, August 12). The American Bike Boom. Retrieved June 3, 2016, from <http://bikeretrogrouch.blogspot.com/2014/08/the-american-bike-boom-1970s.html>
27. AAA report - Bicycles in the 1970s. (1978). Retrieved June 3, 2016, from <http://truewheelers.org/research/studies/aaa/02users.htm>
28. Angell, W. (2015, July 29). Why are bicycle sales declining (for the 14th year)? Retrieved June 3, 2016, from <http://streets.mn/2015/07/29/why-are-bicycle-sales-declining-for-the-14th-year/>
29. U.S. Bicycle industry - statistics & facts. (2016, January 14). Retrieved June 3, 2016, from <http://www.statista.com/topics/1448/bicycle-industry-in-the-us/>
30. Blue, E. (2014). *Bikenomics: How bicycling will save the economy (if we let it)*. United States: Microcosm Publishing.
31. Copenhageners love their bikes. Retrieved June 3, 2016, from <http://denmark.dk/en/green-living/bicycle-culture/copenhageners-love-their-bikes/>
32. Bicycle usage Europe. (2014). Retrieved June 3, 2016, from ECF - European Cyclists, <https://ecf.com/resources/cycling-facts-and-figures>
33. Cycle super highway Copenhagen. Retrieved June 3, 2016, from <http://denmark.dk/en/green-living/bicycle-culture/cycle-super-highway/>
34. Walker, P. (2011, December 13). Cycle like the Danes to cut carbon emissions, says study. The Guardian. Retrieved from <http://www.theguardian.com/environment/2011/dec/12/cycle-like-danes-cut-emissions>
35. Cycle Tourism in Europe. Retrieved June 3, 2016, from <https://ecf.com/news/cycling-tourism-europes-44-billion-euro-gold-mine>
36. Bureau, U. C., & Division, D. I. (2013, July 17). US Census Population estimates. Retrieved June 3, 2016, from <http://www.census.gov/popest/about/terms.html>
37. President, S. V. (2016). U.S. Car sales from 1951 to 2015 (in units). Retrieved June 4, 2016, from Statista .com, <http://www.statista.com/statistics/199974/us-car-sales-since-1951/>
38. Gluskin, the, & of, 47 %. (2015). Industry overview 2015 - national bicycle dealers association. Retrieved June 4, 2016, from National Bicycle Dealers Association, <http://nbda.com/articles/industry-overview-2012-pg34.htm>
- 39., *Bicycling magazine*. (2015, December 1). Bicycling's top 50. Retrieved June 4, 2016, from Bicycling .com, <http://www.bicycling.com/rides/adventure-guide/bicyclings-top-50>
40. Bridge, R. (2009). *Bike touring: The Sierra Club guide to travel on Two wheels* (2nd ed.). United States: Sierra Club Books.
41. Petersen, G., & Takahashi, R. (2012). *Just ride: A radically practical guide to bikes, equipment, health, safety, and attitude*. New York: Workman Publishing Company.
42. Conservancy, R. (2001). About us | rails-to-trails conservancy. Retrieved June 4, 2016, from Rails to Trails Conservancy, <http://www.railstotrails.org/about/about-us/>

43. Home. (2012, November 7). Bikecentennial: Summer of 1976 | about us. Retrieved June 4, 2016, from Adventure Cycling Association, <https://www.adventurecycling.org/about-us/history/bikecentennial-summer-of-1976/>
44. Home. (2015, November 10). Adventure cycling route network. Retrieved June 4, 2016, from Adventure Cycling Association, <https://www.adventurecycling.org/routes-and-maps/adventure-cycling-route-network/>
45. Home. (2015, November 12). U.S. Bicycle route system (USBRS). Retrieved June 4, 2016, from Adventure Cycling Association, <https://www.adventurecycling.org/routes-and-maps/us-bicycle-route-system/>
46. Conservancy, R. (2016). John Wayne Pioneer trail. Retrieved June 4, 2016, from Trail Link, <http://www.traillink.com/trail/john-wayne-pioneer-trail.aspx>
47. Home. (2014, August 28). Cyclists only camping: Barn bicycle camping. Retrieved June 4, 2016, from Adventure Cycling Association, <https://www.adventurecycling.org/resources/blog/cyclists-only-camping-barn-bicycle-camping/>
48. Home. (2013, January 7). Twin bridges: Rural friendliness pays dividends | adventure cyclist. Retrieved June 4, 2016, from Adventure Cycling Association, <https://www.adventurecycling.org/adventure-cyclist/online-features/twin-bridges-rural-friendliness-pays-dividends/>
49. Hospitality for touring cyclists worldwide. Retrieved June 4, 2016, from Warm Showers .org, <https://www.warmshowers.org/>
50. Recreational Economy Report. Retrieved June 4, 2016, from Outdoor Industry .org, <https://outdoorindustry.org/images/researchfiles/RecEconomypublic.pdf>
51. Home. (2015, October 2). Economic impact | U.S. Bicycle route system. Retrieved June 4, 2016, from Adventure Cycling Association, <https://www.adventurecycling.org/routes-and-maps/us-bicycle-route-system/benefits-and-building-support/economic-impact/>
52. Washington Recreational Economy Report. Retrieved June 4, 2016, from Washington Recreation and Conservation Office, <http://www.rco.wa.gov/documents/ORTF/EconomicAnalysisOutdoorRec.pdf>
53. The Economic Significance of Bicycle-Related Travel in Oregon. Retrieved June 4, 2016, from Dean Runyan .com, http://www.deanrunyan.com/doc_library/bicycletravel.pdf
54. Economy and Health Benefits of Bicycling in Iowa. Retrieved June 4, 2016, from University of Northern Iowa, http://www.peoplepoweredmovement.org/site/images/uploads/Economic_and_Health_Benefits_of_Bicycling_in_Iowa.pdf
55. Home. (2013, January 2). Circulation and demographics | adventure cyclist. Retrieved June 4, 2016, from Adventure Cycling Association, <https://www.adventurecycling.org/adventure-cyclist/advertise/circulation-and-demographics/>
56. Home. (2015, July 29). Guided tours. Retrieved June 4, 2016, from Adventure Cycling Association, <https://www.adventurecycling.org/guided-tours/>
57. Hipcamp. (2016). About Hip Camp. Retrieved June 5, 2016, from Hip Camp .com, <https://www.hipcamp.com/about>
58. Reserved, I. A. R. (2012, November 6). Asset-based economic development and building sustainable rural communities. Retrieved June 5, 2016, from ICMA, http://icma.org/en/results/sustainable_communities/resources/blogpost/901
59. Reserved, I. A. R. (2012, November 6). Asset-based economic development and building sustainable rural communities. Retrieved June 5, 2016, from ICMA, http://icma.org/en/results/sustainable_communities/resources/blogpost/901/AssetBased_Economic_Development_and_Building_Sustainable_Rural_Communities
60. Home. (2015, July 29). Guided tours. Retrieved June 5, 2016, from Adventure Cycling Association, <https://www.adventurecycling.org/guided-tours/>

61. Home. (2015, August 4). 2016 northern tier - van | guided tours. Retrieved June 5, 2016, from Adventure Cycling Association, <https://www.adventurecycling.org/guided-tours/van-supported-tours/2016-northern-tier/>
62. Bicycle speed (velocity) and power calculator. Retrieved June 5, 2016, from Kreuzotter .de, <http://www.kreuzotter.de/english/espeed.htm>
63. Bicycle Statistics from Denmark. Retrieved June 5, 2016, from Cycling Embassy of Denmark, <http://www.cycling-embassy.dk/wp-content/uploads/2010/03/Bicycle-statistics-from-Denmark.pdf>
64. Medicine, I. of. (2015, August 19). Dietary reference Intakes: Water, potassium, sodium, chloride, and Sulfate: Health and medicine division. Retrieved June 6, 2016, from Institute of Medicine, <http://www.nationalacademies.org/hmd/Reports/2004/Dietary-Reference-Intakes-Water-Potassium-Sodium-Chloride-and-Sulfate.aspx>
65. Foundation, M., Education, M., & Research (2014). Nutrition and healthy eating. MayoClinic. Retrieved from <http://www.mayoclinic.org/healthy-lifestyle/nutrition-and-healthy-eating/in-depth/water/art-20044256?pg=2>
66. Estimated Calorie per person per day. Retrieved June 6, 2016, from USDA Center for Nutrition Policy and Promotion, http://www.cnpp.usda.gov/sites/default/files/usda_food_patterns/EstimatedCalorieNeedsPerDayTable.pdf
67. TheAverageBody. Average weight - information on average female and male weight. Retrieved June 6, 2016, from The Average Body .com, http://www.theaveragebody.com/average_weight.php
68. Cycling calories burned calculator. (2015, November 12). Retrieved June 6, 2016, from Bicycling Magazine, <http://www.bicycling.com/training/weight-loss/cycling-calories-burned-calculator>
69. Yellowstone visitation tops 4 Million for the First time. (2016, January 12). Retrieved June 6, 2016, from National Park Service, <https://www.nps.gov/yell/learn/news/16002.htm>
70. Plan your visit. Retrieved June 6, 2016, from National Park Service, <https://www.nps.gov/yell/planyourvisit/index.htm>
71. Climate Anacortes - Washington. (2016). Retrieved June 6, 2016, from US Climate Data, <http://www.usclimatedata.com/climate/anacortes/washington/united-states/uswa0011>
72. ANACORTES, WASHINGTON - climate summary. Retrieved June 6, 2016, from Western Region Climate Center, <http://www.wrcc.dri.edu/cgi-bin/cliMAIN.pl?waanac>
73. Climate republic - Washington. (2016). Retrieved June 6, 2016, from US Climate Data, <http://www.usclimatedata.com/climate/republic/washington/united-states/uswa0370>
74. OWSC: WA cloud cover. Retrieved June 6, 2016, from University of Washington, <http://www.climate.washington.edu/cloudcover/#bellingham>
75. Daylight or darkness duration table for One year. Retrieved June 6, 2016, from US Naval Observatory, http://aa.usno.navy.mil/cgi-bin/aa_durtable.pl?form=1&year=2016&task=-1&state=WA&place=anacortes
76. Allen, E., & Iano, J. (2012). The architect's studio companion: Rules of thumb for preliminary design(5th ed.). United Kingdom: Wiley, John & Sons.
77. Design with wood CLT. (2008). Retrieved June 6, 2016, from Wood Works .org, <http://www.woodworks.org/design-with-wood/building-systems-clt/>
78. Design with wood. (2008). Retrieved June 6, 2016, from <http://smartlam.com/about-clt/process/>, <http://www.woodworks.org/design-with-wood/building-systems-clt/>
79. Sustainable Forestry in North America Report. Retrieved June 7, 2016, from Wood Works .org, <http://www.woodworks.org/wp-content/uploads/IS-Forestry.pdf>

80. Indicator 2.13: Annual harvest of wood products. (2014, April 29). Retrieved June 7, 2016, from US Forest Service, <http://www.fs.fed.us/research/sustain/criteria-indicators/indicators/indicator-213.php>
81. 666, admin_. (2013, July 29). Embodied energy. Retrieved June 7, 2016, from Australian Government - Your Home Australian's Guide to Environmentally Sustainable Homes, <http://www.yourhome.gov.au/materials/embodied-energy>
82. Martinez, T. (2015, August 21). Sustainable building: Why wood is our most valuable resource | U.S. Green building council. Retrieved June 7, 2016, from US Green Building Council, <http://www.usgbc.org/articles/sustainable-building-why-wood-our-most-valuable-resource>
83. Embodied Energy of Materials. Retrieved June 8, 2016, from University of Michigan, <http://www.umich.edu/~nppcpub/research/lcahome/IMG00043.GIF>
84. Concrete and embodied energy - can using concrete be carbon neutral. Retrieved June 8, 2016, from Strine Environments, <http://strineenvironments.com.au/factsheets/concrete-and-embodied-energy-can-using-concrete-be-carbon-neutral/>
85. Jones, C. P. (2016). Flood resistance of the building envelope. Retrieved June 8, 2016, from Whole Building Design Guide, https://www.wbdg.org/resources/env_flood.php
86. PVWatts calculator. Retrieved June 9, 2016, from National Renewable Energy Laboratory, <http://pvwatts.nrel.gov/pvwatts.php>
87. Allen, E., & Iano, J. (2012). The architect's studio companion: Rules of thumb for preliminary design (5th ed.). United Kingdom: Wiley, John & Sons. Excel composting toilet by sun-mar. Retrieved June 9, 2016, from Sun-Mar, http://www.sun-mar.com/prod_self_exce.html
88. Excel composting toilet by sun-mar. Retrieved June 9, 2016, from Sun-Mar, http://www.sun-mar.com/prod_self_exce.html
89. Sherman Pass road and weather conditions. (2016, June 8). Retrieved June 9, 2016, from Washington State Department of Transportatino, <http://www.wsdot.com/traffic/passes/sherman/>
90. Name, Y. (2001). Republic, Washington. Retrieved June 9, 2016, from Ferry County .com, <http://www.ferrycounty.com/communities/republic-washington/>
91. About kettle falls. Retrieved June 9, 2016, from Kettle - Falls .com, <http://www.kettle-falls.com/about-kettle-falls>
92. Cross-laminated timber (CLT). (2016). Retrieved June 10, 2016, from APA, <http://www.apawood.org/cross-laminated-timber>

Figures

1. By Wilhelm Siegrist (1797-1843?) [Public domain], via Wikimedia Commons [Illustration of the Draisine of 1817]. (n.d.). Retrieved from <https://commons.wikimedia.org/wiki/File:Draisine1817.jpg>
2. Velocipede circa 1869. (n.d.). Retrieved from <https://crowdstory.files.wordpress.com/2012/07/velocipede-1869.jpg?w=600>
3. Columbia Bicycles Flyer. (n.d.). Retrieved from <https://s-media-cache-ak0.pinimg.com/736x/44/f1/16/44f1160dc35c5e1bba5358ef41e72e39.jpg>
4. Rover Safety Bicycle [Photograph]. (n.d.). In [Http://www.ssplprints.com/image/92942/rover-safety-bicycle-1885](http://www.ssplprints.com/image/92942/rover-safety-bicycle-1885).
5. Dunlop Pneumatic Tires on a Tricycle [Photograph]. (n.d.). In [Http://www.sterba-bike.cz/media/foto/3/img97442a9199d2fd1d10c184941fa90073.jpg](http://www.sterba-bike.cz/media/foto/3/img97442a9199d2fd1d10c184941fa90073.jpg).
6. Golden Age of Bicycles. (n.d.). Retrieved from http://blog.nyhistory.org/wp-content/uploads/2011/05/nyhs_pr068_cycling_grantsto.jpg
7. Wright Cycle Exchange Flyer. (n.d.). Retrieved from http://www.wright-brothers.org/Information_Desk/Just_the_Facts/Bicycles/Wright_Bicycles_images/1893-Wright-Cycle-Exchange-Ad.jpg
8. 1909 Wright Brothers Military Flyer. Retrieved June 3, 2016, from Wright Brothers .org, http://www.wright-brothers.org/Information_Desk/Just_the_Facts/Airplanes/Wright_Airplane_images/1909_Military_Flyer/1909_Fort_Myer_gassing_up.jpg
9. Ford Model T. Retrieved June 3, 2016, from Bold Ride .com, <http://f.images.boldride.com/ford/1917/ford-model-t-1306233807-593.jpg>
10. Good Roads Building at UW. (1909). Retrieved June 3, 2016, from https://commons.wikimedia.org/wiki/File%3AREport_of_the_Alaska-Yukon-Pacific_Exposition_Commission_of_the_state_of_Washington_-_Page_52.jpg
11. US Interstate System. Retrieved June 4, 2016, from Federal Highway Administration, <http://www.fhwa.dot.gov/planning/images/thnhjsjpg.jpg>
12. Decommissioned Street Cars. Retrieved June 4, 2016, from Market Urbanism .com, <http://marketurbanism.com/wp-content/uploads/2010/09/streetcar.jpg>
13. Leon Mill spray-paints a sign outside his Phillips 66 station in Perkasio, Pa. Retrieved June 4, 2016, from NPR .org, <http://media.npr.org/assets/img/2013/10/16/ap7306010161-043a4de622c4771515f2e3d9656073a15c9fee82-s300-c85.jpg>
14. Schwinn Sting Ray. Retrieved June 3, 2016, from http://3.bp.blogspot.com/-4C_CDp-g_U/U-k43AtJ0xI/AAAAAAAADfY/prmtlivGaX8/s1600/stingray.jpg
15. Schwinn Varsity 10 Speed Bicycle. Retrieved June 3, 2016, from http://4.bp.blogspot.com/-CFm4RqAo_eU/U-kzkDi3JjI/AAAAAAAADfI/xXJjf-CVYwuU/s1600/schwinnvarsity.jpg
16. AAA Bicycle Sales Chart. Retrieved June 3, 2016, from <http://truewheelers.org/research/studies/aaa/images/fig01.gif>
17. Mountain Biking. Retrieved June 3, 2016, from <https://i.ytimg.com/vi/61aM0DXpKkc/maxresdefault.jpg>
18. Surly Long Haul Trucker. Retrieved June 3, 2016, from Pedal Shift .net, <http://pedalshift.net/wp-content/uploads/2015/02/surly-long-haul-trucker.jpg>
19. 1924 Ford Advertisement. Retrieved June 3, 2016, from <http://www.american-automobiles.com/Ford/1924-Ford-Touring-Car.jpg>
20. Bicycling in Copenhagen. Retrieved June 3, 2016, from <http://denmark.dk/~media/Denmark/Images/Green%20living/Bicycle/highheels580.jpg?w=580&h=360&as=1>
21. Bicycle Super Highway in Denmark. Retrieved June 3, 2016, from http://www.cycling-embassy.dk/wp-content/uploads/2012/06/Cykelsuperstier_IMG_0777_En-midlertidig-orange-stribe-skal-g%C3%B8re-det-nemmere-at-finde-vej-de-f%C3%B8rste-par-uger.jpg

22. Minneapolis Winter Biking. Retrieved June 4, 2016, from Streets Blog .org, <http://usa.streetsblog.org/wp-content/uploads/sites/5/2011/05/winter-bike.jpg>
23. Cycling Tourist Yoga Pose. Retrieved June 4, 2016, from Washington Bikes, <http://wabikes.org/wp-content/uploads/2014/05/Bike-Travel-Yoga-Tree-Pose.jpg>
24. 2016. (2004). Rolling tales: Small adventures by bicycle. Retrieved June 4, 2016, from Rolling Tales .com, <http://www.rolling-tales.com/gear>
25. Bike Touring In Peru. Retrieved June 4, 2016, from Family On Bikes .org, <http://familyonbikes.org/blog/wp-content/uploads/2012/09/peru-desert.jpg>
26. Victoria Clipper by the Seattle Waterfront. Retrieved June 4, 2016, from You Tube .com, <https://i.ytimg.com/vi/0c0ZfsKr9BM/maxresdefault.jpg>
27. Grant Peterson. Retrieved June 4, 2016, from Brooks England, <http://blog.brooksengland.com/wps/wp-content/uploads/2012/11/Grant-Petersen-Author-Photo.jpg>
28. John Wayne Pioneer Trail Map. Retrieved June 4, 2016, from MTBR .com, http://fcdn.mtbr.com/attachments/washington/709798d1342070379-john-wayne-pioneer-trail-iron-horse-state-park-cross-state-tour-route_shot.jpg
29. ACA Map on Bicycle Handlebars. Retrieved June 4, 2016, from Adventure Cycling Association, https://www.adventurecycling.org/default/assets/Image/Slatwall/product/default/cache/BT-225_600w_600h_sb.jpg
30. 1976 Bikecentennial Poster. Retrieved June 4, 2016, from Bike Pedal .com, http://65.media.tumblr.com/cba836751791126b4156975b5a1f014e/tumblr_inline_nomxehJn7a1t012jk_500.jpg
31. ACA Route Network. Retrieved June 4, 2016, from Omni Map .com, <http://www.omnimap.com/catalog/images/cycling/ACA-route-i.jpg>
32. USBR10 Route in Washington State. Retrieved June 4, 2016, from Seattle Bike Blog .com, http://1p40p3gwj70rhpc423s8rzjaz.wpengine.netdna-cdn.com/wp-content/uploads/2014/04/USBR10_Overview-Map.jpg
33. U.S. Bicycle route 21, 121, and 121A. (2015, September 22). Retrieved June 4, 2016, from Bike and Walk Tennessee, http://www.bikewalktn.org/u_s_bicycle_route_21_121_and_121a
34. Bike Camping in the Forest. Retrieved June 4, 2016, from Pedal Power Touring .com, http://pedalpowertouring.com/wp-content/uploads/2012/07/IMG_3075.jpg
35. Hiker Biker Camp Site. Retrieved June 4, 2016, from Tasting Travels .com, http://www.tastingtravels.com/wp-content/uploads/2016/01/IMG_20151020_082652.jpg
36. Hiker Campsite. Retrieved June 4, 2016, from Bainbridge Island Metro Park and Recreation District, http://www.biparks.org/biparks_site/parks/images/faybainbridge/faybainbridgecampsites/sitehiker-bikerA.jpg
37. Gavelda, B. (n.d.). White Fish Bike Retreat 01.
38. Whitefish Bike Retreat. (n.d.). Trails around Whitefish, MT.
39. Whitefish Bike Retreat. (n.d.). Amenities at Whitefish Bike Retreat.
40. Gavelda, B. (n.d.). Whitefish Bike Retreat Shuttle Van.
41. Cyclists arriving at Bicycle Barn Camping. Retrieved June 4, 2016, from Adventure Cycling Association, https://www.adventurecycling.org/default/assets/Image/blog/GeoPoints/August_2014/Bicycle_Barn_family_07_13.jpg
42. Cycling Tourist at Bike Barn Camping. Retrieved June 4, 2016, from Adventure Cycling Association, https://www.adventurecycling.org/default/assets/Image/blog/GeoPoints/August_2014/Bicycle_Barn_Nora_Joe_08_14.jpg
43. Twin Bridge Bike Camp. Retrieved June 4, 2016, from Adventure Cycling Association, https://www.adventurecycling.org/default/assets/Image/AdventureCyclist/OnlineFeatures/TwinBridges/TwinBridges_1.jpg
44. Twin Bridges Bike Camp Donations Sign. Retrieved June 4, 2016, from Adventure Cycling Association, https://www.adventurecycling.org/default/assets/Image/AdventureCyclist/OnlineFeatures/TwinBridges/TwinBridges_3.jpg

45. Bill White looking over Bike Camp in Twin Bridges. Retrieved June 4, 2016, from Adventure Cycling, https://www.adventurecycling.org/default/assets/Image/AdventureCyclist/OnlineFeatures/TwinBridges/TwinBridges_4.jpg
46. The Hospitality of Strangers. Retrieved June 4, 2016, from Rosy and Jim Tour de World, https://rosyandjimstourdeworld.files.wordpress.com/2013/04/img_3386.jpg
47. EELLS, M. (n.d.). The Eells at Logan Pass.
48. Eells, M. (n.d.). The Eells Family Cycling
49. Eells, M. (n.d.). Michael Eells enjoying the view.
50. Garland, R. (n.d.). Richard Garland by Big Sur.
51. Group Touring. Retrieved June 4, 2016, from Bike Tour Network .com, <http://biketournetwork.com/wp-content/uploads/2014/12/rtrphoto.png>
52. Okonski, M. (2016). Group Touring Graphic.
53. A Family Touring Together. Retrieved June 5, 2016, from The Family Ride .com, <http://www.thefamilyride.com/wp-content/uploads/2013/05/145.jpg>
54. Okonski, M. (2016). Cycling Distance vs Time Chart.
55. Okonski, M. (2016). Cycling Distance vs Water Consumption Chart.
56. Okonski, M. (2016). Cycling Distance vs Calories Burned Chart.
57. Okonski, M. (2016). Cycling Distance vs water and calories.
58. Okonski, M. (2016). An Example day of cycling and resources.
59. Okonski, M. (2016). Bicycle Economy in the US.
60. Okonski, M. (2016). Bicycle Industry in Washington State.
61. Okonski, M. (2016). Bicycle Industry in Oregon State.
62. Okonski, M. (2016). Northern Tier Route through Washington State.
63. John Pope. Retrieved June 5, 2016, from Washington Bikes .org, <http://wabikes.org/wp-content/uploads/2014/09/Ferry-terminal.jpg>
64. Okonski, M. (2016). Washington State Bicycle Routes.
65. Okonski, M. (2016). Route Nodes in Washington State.
66. Okonski, M. (2016). 30 Mile Intervals along the NTR in Washington State.
67. Okonski, M. (2016). Contextual 30 Mile Intervals along the NTR in Washington State.
68. Touring Cyclist in the Rain. Retrieved June 6, 2016, from Down The Road .ord, <http://www.downtheroad.org/Equipment/Pictures-Equipment/DSC00092.JPG>
69. Okonski, M. (2016). Contextual terrain map of Washington State.
70. Okonski, M. (2016). Climate Comparison of three shelter locations along the NTR in Washington State.
71. Adventure Cycling Association. (n.d.). Route Elevation Profile - NTR in Washington State.
72. State, W. Solar and wind maps for Washington state. Retrieved June 6, 2016, from Washington State Department of Ecology, http://www.ecy.wa.gov/climatechange/greenenergy_maps.htm
73. Handlebar GPS Unit. Retrieved June 6, 2016, from Bicycle Illinois, <http://www.bicycleillinois.com/policiesandprocedures/onroadsupportservices/navigation/mountedgpsunit.jpg>
74. Okonski, M. (2016). Washington State is Perfect for Bicycle Tourism.
75. Cycling Tourists with Dogs. Retrieved June 6, 2016, from Travelling Two .com, <http://gallery2.travellingtwo.com/d/38669-2/nor030.jpg>
76. An Arch Made of Bicycles. Retrieved June 6, 2016, from pinimg .com, <https://s-media-cache-ak0.pinimg.com/736x/03/d8/85/03d885b4d-29061ced9e3d7acc9619249.jpg>
77. Okonski, M. (2016). Programmatic Elements
78. Okonski, M. (2016). Programmatic Considerations
79. Prefabricated Construction. Retrieved June 9, 2016, from Modular Classrooms .org, <http://www.modularclassrooms.org/wp-content/uploads/2013/07/prefabricated-construction-at-a-factory.jpg>

80. US Forest Inventory Growth vs Removal Chart. Retrieved June 7, 2016, from US Forest Service, <http://www.fs.fed.us/research/sustain/images/criteria-indicators/indicatorimages/figure13-2.JPG>
81. CLT Panels ready to ship. Retrieved June 6, 2016, from Smart Lam, <http://smartlam.wfwdemo.com/wp-content/uploads/2015/05/SmartLam34-edit-3000px-1024x683.jpg>
82. CLT Press Rendering. Retrieved June 7, 2016, from Minda, http://www.minda.de/files/minda/produkte/holz/minda_holz_bsp-presse.jpg
83. Okonski, M. (2016). CLT Panel Material Waste and reuse Graphic
84. Okonski, M. (2016). Photo of a Model of Bicycle Infrastructure Signage
85. Watson, T. Bicycle Sculpture by Donald Lipski. Retrieved June 9, 2016, from Inspiration Green .com, <http://www.inspirationgreen.com/assets/images/Art/Bicycles/Donald%20lipski.jpg>
86. Bicycle Gate Sculpture. Retrieved June 9, 2016, from Inspiration Green via www.funfunpics.blogspot.com, <http://www.inspirationgreen.com/assets/images/Art/Bicycles/bike-gate-.jpg>
87. Berner, A. Tourist with Rachel the Pig. Retrieved June 9, 2016, from The Seattle Times, <http://static.seattletimes.com/wp-content/uploads/2015/12/8957f594-a5e9-11e5-9c4b-70aea859ce73-1020x1395.jpg>
88. Okonski, M. (2016). Roof and Enclosure Sketch.
89. Sun Chart Bellingham Wa. Retrieved June 9, 2016, from Gaisma .com, <http://www.gaisma.com/en/sunpath/bellingham-washington.png>
90. Okonski, M. (2016). Climate Responsive design strategies diagram
91. Okonski, M. (2016). Roof, Enclosure & Extrusion Sketch.
92. Okonski, M. (2016). Program vs Enclosure Diagram
93. Okonski, M. (2016). 3 building types diagram
94. Okonski, M. (2016). Small site layout diagram
95. Okonski, M. (2016). Medium site with a flat site diagram
96. Okonski, M. (2016). Medium site with a steep site diagram
97. Okonski, M. (2016). A larger site showing a connected structure
98. By User:Dschwen (Own work) [CC BY-SA 2.5 (<http://creativecommons.org/licenses/by-sa/2.5/>)], via Wikimedia Commons. Dripping Faucet. Retrieved June 9, 2016, from Wiki Media .org, https://upload.wikimedia.org/wikipedia/commons/5/58/Dripping_faucet_1.jpg
99. Excel composting toilet by sun-mar. Retrieved June 9, 2016, from Sun-Mar, http://www.sun-mar.com/prod_self_exce.html
100. Okonski, M. (2016). Water System Diagram
101. Okonski, M. (2016). Electrical System Diagram
102. Okonski, M. (2016). Monitoring System Diagram
103. Google maps. Retrieved June 9, 2016, from Google, <https://www.google.com/maps/place/Republic,+WA+99166/@48.6095929,-118.4133927,34045m/data=!3m1!1e3!4m2!1m1!5!4m1!1m6!1m2!1s0x5362840988827b4f:0x8a854fbc7b65ea38!2sKettle+Falls,+WA!2m2!1d-118.0558218!2d48.6107354!1m6!1m2!1s0x549d6ea629f1965:0x5905f1f1bf44886d!2sRepublic,+WA+99166!2m2!1d-118.7378067!2d48.6482183!3m4!1s0x549d6ea629f1965:0x5905f1f1bf44886d!8m2!3d48.6482183!4d-118.7378067>
104. Google maps: Sherman Pass. Retrieved June 9, 2016, from Google, <https://www.google.com/maps/@48.6102811,-118.462449,2468m/data=!3m1!1e3>
105. Okonski, M. (2016). Sherman Pass Site Program Diagram
106. Okonski, M. (2016). Shelter Building Envelope Diagram
107. geologicfoundations (2012, April 25). GeoLOGIC screw pile installation Retrieved from <https://www.youtube.com/watch?v=Kx7H1YJT44s>
108. Okonski, M. (2016). Sherman Pass Shelter Foundation Plan
109. Okonski, M. (2016). Sherman Pass Shelter Floor Plan
110. Okonski, M. (2016). Sherman Pass Shelter Section
111. Okonski, M. (2016). Sherman Pass Shelter Lighting Plan
112. Okonski, M. (2016). A Rendering of the proposed bicycle infrastructure signage.

113. Okonski, M. (2016). A Rendering of the shelter at night.
114. Okonski, M. (2016). A Rendering of the shelter at night around the fire pit.
115. Okonski, M. (2016). A photography of the final tectonic model.
116. Okonski, M. (2016). A photography of site model 1.
117. Okonski, M. (2016). A photography of site model 2

Additional Acknowledgements

There were many people who I interviewed for this project who contributed their time and shared their thoughts. I would like to thank the following people:

Saara Snow and the folks at Adventure Cycling Association, Barb Chamberlain and the folks at Cascade Bicycle Club and Washington Bikes, John Pope, Rick Garland, The Eells Family, Russ and Laura from PathLessPedaled.com, Jason Goodman and the folks at Swift Industries, Julie Muyllaert, Julie Murrell and the folks at HipCamp.com, Jim Gregg, Cricket Butler, William White, Mark Martin and the folks at WarmShowers.org, Melika Inanici, Christopher Meek, Mary Tepas and the folks at SmartLam, the folks at Surly, and many others. Thank you for taking the time to help me on my project.

Lastly, I would like to thank Google for their products and services. I couldn't imagine doing this project 20-40 years ago. Google's products were invaluable to me during this time. So, thank you.