

Learn to Work:
A Job Corp Magnet Program in Seattle

Bradley T. Ecklund

A thesis
submitted in partial fulfillment of the
requirements for the degree of:
Master of Architecture

University of Washington
2017

Committee:
Gundula Proksch
David Miller

Program Authorized to Offer Degree:
Architecture

© Copyright 2017
Bradley T. Ecklund

University of Washington

Abstract

Learn to Work:
A Job Corps Magnet Program in Seattle

Bradley T. Ecklund

Co-Chairs of the Supervisory Committee:
Gundula Proksch
David Miller

The United States is dealing with a skilled labor shortage. Many factors contribute this but ultimately, the conclusion is that it stems from three main factors: the lack of ready to work skills from current graduates, social de-valuation of skilled labor, and changes in the nature of work due to automation. This coincides with a growing gap between the upper and middle class. This thesis proposes a trade school that will train young adults in the skill of additive manufacturing as a way to address the skilled labor shortage and enter the job market with a competitive edge. By tying in to the existing framework of Job Corps, this Seattle magnet program will provide technical training to a population of under-privileged men and women.

Thank you...

To my wife, Jana, who I'm sure is excited to have me back on evenings and weekends. Thank you for your support, love, and understanding during my time at school.

To my family who has wished only the best for me and always encouraged me.

To my friends, I no longer have the excuse of school to not hang out.

To my fellow students for feedback, direction, and entertaining studio conversations.

To all of the faculty and administration who pushed the research and design beyond what I could reach on my own.

Learn to Work:

A Job Corp Magnet Program in Seattle



A Master of Architecture Thesis by
Bradley T. Ecklund

This page is blank.

TABLE OF CONTENTS

1	1. Introduction
	1.1 – Introduction and Problem Statement
2	2. Theoretical Framework
	2.1 – CTE (Career and Technical Education) and Experiential Learning
	2.2 – Job Corps
	2.3 – Architecture and CTE Programs
21	3. Precedents and Program Analysis
	3.1 – Kwartha Trades and Technology Centre
	3.2 – Jacobs Institute for Design Innovation
	3.3 – Deakin Trade Training Centre
28	4. Methods
	4.1 – Goals and Objectives
	4.2 – Neighborhood and Site Selection
	4.3 – Program Analysis
36	5. Site Analysis
	5.1 – Site Analysis
41	6. Design Response
	6.1 - Concept of Design
	6.2 - Final Design
58	7. Conclusion
	7.1 - Conclusion
60	Bibliography
62	Appendix

INTRODUCTION

The United States is experiencing a serious shortage of skilled labor. Professionals and researchers in education and economics agree that this problem stems from three main issues: the lack of ready-to-work skills in current graduates, social de-valuation of trade jobs, and changes in the nature of work due to advances in technology. Vocational training, or career and technical education, has existed in this country since the early twentieth century. However, this type of education continues to be stigmatized and overlooked. This thesis argues that architecture can play a role in revitalizing the status of this valuable form of learning. The proposed design of a Job Corps Urban training center for Seattle seeks to provide a physical space to learn, train, and work. At the same time the building will give an identity to this type of education in order to restore the prestige of the skilled worker. This Seattle magnet program will provide specialized training in additive manufacturing, or 3-D printing, an emerging field in technology. The Job Corps Urban Training Center in Seattle will be the hub in the Pacific Northwest for learning this emergent technology. This thesis seeks to explore how a building with a specialized training program can help meet some of these needs, specifically tailored to the Seattle region.

2. Theoretical Framework

2.1 – The Vocational School Model and Experiential Education

Today the idea of vocational education is thought of as job skills training. Vocational programs in America began officially in 1917 when Congress passed the Smith-Hughes Act. At this time, the focus was on agricultural production, industrial work, and national security, namely for jobs related to wartime industries. As Lia Epperson notes, from its official beginnings job related training “responded to the needs of the economy and the political pressures of the times,” (Epperson, 3). The Federal government continue to pass legislation supporting vocational training especially for low-income communities, further expanding the scope of vocational programs to offer more than just basic job skills training with the Vocational Education Act of 1963 which attempted to expand the definition of “vocational education” by including some jobs typically seen as white collar (Epperson, 3). The Carl D. Perkins Vocational Education Act was passed in 1984, aimed to provide more opportunities for at-risk students. In 1984 the current legislation regarding vocational programs under the Carl D. Perkins Vocational Education Act was established.

After several amendments and updates it was renamed the Carl D. Perkins Career and Technical Education Act in 2006 (Imperatore). After several amendments this legislation was renamed in order to replace “vocational” with “career and technical” education. CTE as it is known today, is typically used to describe vocational schools and programs. One of the major tenants of more recent updates to the legislation has been the attempt to further integrate

education beyond basic job training within the CTE schools in order to provide greater opportunities for students (Epperson, 3).

What does a typical CTE center today seek to accomplish? Typically, they are available to students with a GED or high school degree. The main goal is to provide young adults with the skills necessary to work within a specific industry. Community colleges are generally state or city run facilities that can provide a basic training for many jobs and are funded or coordinated by the Perkins CTE Act of 2006. Many times, CTE programs or courses can fall within the purview of a larger community college. CTE programs can also exist independently of community college systems. Like dedicated CTE centers, community colleges are generally a less expensive but still viable alternative form of post high school education for many people.

Historically, the idea of CTE programs have been stigmatized, due in large part to critics claiming that early years of legislation had been a vehicle for class segregation (Epperson, 3). To this day, students who attend CTE centers tend to be from poor and marginalized families. (Hanford) But this perception is something that the more recent legislation amendments have been attempting to address and fix. This kind of negative connotation associated with CTE education is unfortunate for two reasons. First, the United States is facing a national skilled labor shortage and secondly, these kinds of job training education programs are a proven education method of experiential learning.

The nation been faced for some time with the problem of a lack of skilled labor. Locally, The Puget Sound Business Journal references a study completed by the American City Business Journals and Deloitte in 2016 where 1,800 US business executives were interviewed with 189 interviews coming from the Seattle area.

Seattle was one of five cities where the interviewees claimed that one of the biggest hurdles to overcome for success was a skills shortage. The report states that “64 percent called it ‘extremely difficult’ to find employees with appropriate skills and education,” indicating the labor problem has hit the Seattle market especially hard (Smith). Career and Technical Education offers students who graduate with ready to work skills so that they can immediately enter the job market. Business reports confirm that these programs result in very high job placements (Kavilanz). But despite these kinds of successful outcomes, CTE education does not receive the attention it deserves. The image of what some still call “vocational” learning continues to be plagued by a negative perception. One



Figure 1 - Traditional vocational school circa Philadelphia in 1911. Credit: PhillyHistory.org

way to alter this perception do this is to provide a new building that people find desirable but more importantly fosters growth and teaches the students life skills and builds connections.

The style of learning in CTE programs falls under the category of what has been more recently called “experiential learning.” (Figure 1) The more typical teaching style of K-12 schools is what is known as cells and bells which is where students sit in class rooms with orderly desks listening to a teacher speak. This was originally a product from the early 20th century, inspired from

the Ford production line (Pesquera), in order to teach as many students as effectively as possible. These rooms are spatially recognized as small squares or rectangles packed with desks. (Figure 2) Cells and bells continued more or less unencumbered by change throughout the century as the education system geared its focus to passing national and state standardized tests, this style of teaching and classroom layout was conducive for such goals (Wurdinger and Carlson, 1).

In contrast to the lecture format of instruction, experiential learning seeks to allow students to be “actively engaged in the learning process.” Scott Wurdinger and Julie Carlson see this as a system that encourages more creativity and innovation, enabling students to reach their potential. In their book, *Teaching for Experiential Learning*, these educators identify the five different approaches to involving students as: project based learning, problem based learning, service learning, place based education and active learning,” (Wurdinger and Carlson, 6-7). Active learning is the basis of experiential learning from which all of the other four processes stem from. These approaches promote a new environment of learning that encourages students into multi-disciplinary and hands on mode of learning. Wurdinger and Carlson refer to a simple definition of experiential learning that is based on the work of Charles Conwell and James Eison, who define it as “anything that involves students doing things and thinking about the things they are doing,” (Wurdinger and Carlson, 17). As a form of experiential learning, Career and Technical Education seeks to teach the student skills beyond the classroom. Research indicates that the type of the skills learned with these methods better prepare students for life (Wurdinger and Carlson, 104). The primary skills learned, according to the Wurdinger and Carlson are creativity, problem solving, decision making, time management, finding information, and most importantly, learning how to learn (Wurdinger

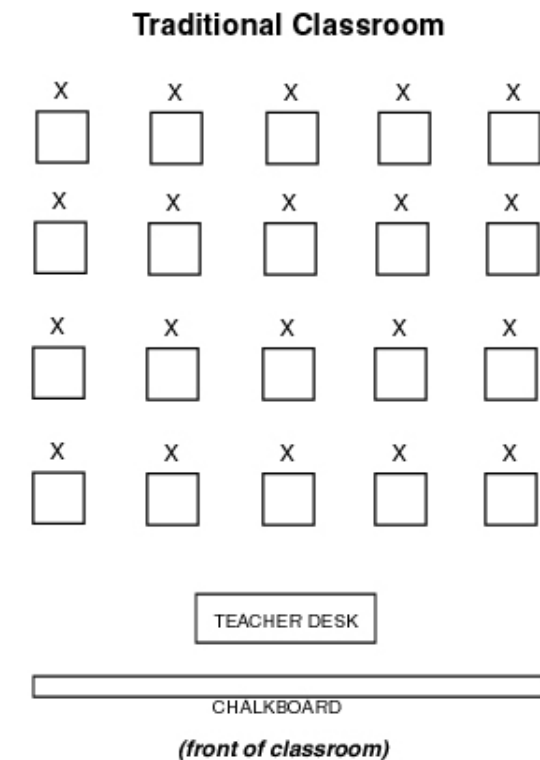

Figure 2 - Cells and bells style classroom desk arrangement.
Credit: learnnc.org

and Carlson, 104). Of particular importance to this architectural thesis, is that this type of education emphasizes a place-based approach.

In the book, *Developing Vocational Expertise*, Stephen Billet observes that the “physical context and artefacts play an important and intermediate role in building connections between objects and events in the social world” (Billet, 233). Billet continues by noting that “physical and social environments are not neutral contexts in which activities occur; they can be a highly constituting component of how we think and act” (Billet, 234). The building where learning takes place can play either a negative or positive role - results in either direction will have long lasting a impact. John Stevenson creates a diagram to represent how a vocational program must be considered as a system of activities with many connecting elements (*Figure 3*). An alternative version of the diagram is proposed here to emphasize the importance of the physical space in which the learning occurs. At the center of connections between teachers and learners, and instruments and community, the building can serve as the all-important center

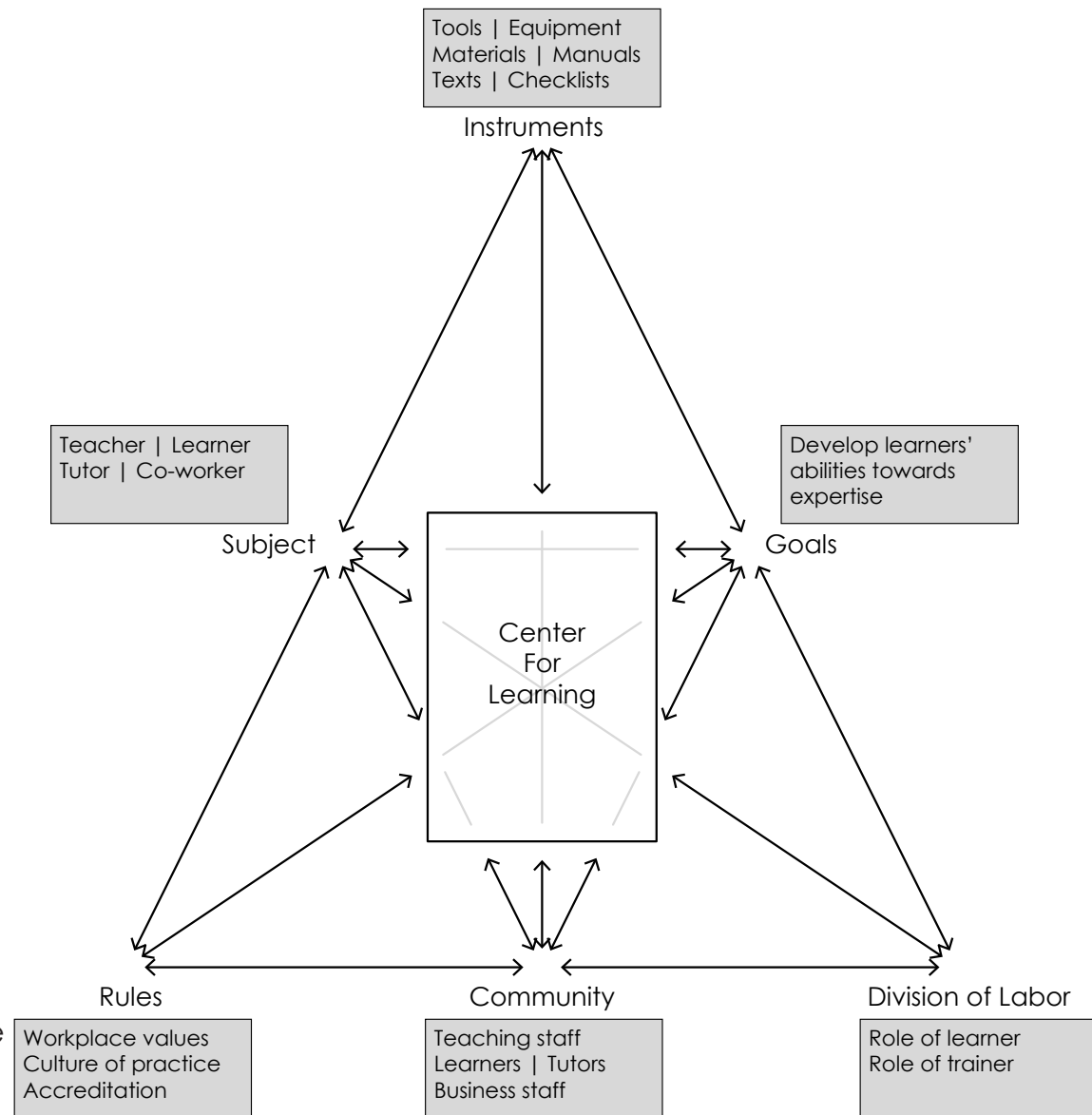

Figure 3 - Teaching and Learning as an activity system. Diagram originally produced by John Stevenson, the diagram seen here has alterations by the author. Credit: John Stevenson.

of learning.

This thesis proposes that the design of a Career and Training Facility can serve as a model for this kind of facility. In its program and site the project seeks to address the skills gap through a comprehensive form of education that emphasizes experiential learning. The program for the design will tie into an existing national format of this kind of educational program.

2.2 – Job Corps

Job Corps is a national program that began in 1964 and currently has 125 locations across the United States. (Figure 4) The program is modeled strongly on the principles of Career and Technical training, where academic and vocational training is provided to disadvantaged youth. The mission statement for the program is: “to set highly motivated young people on a pathway to education and training for successful careers in



Figure 4 - Job Corps locations across the country. Credit: Author, location data from Jobcorps.gov.

the nation's fastest growing industries," (JobCorps.gov). Run by the U.S. Department of Labor, the program typically serves communities that fall into low income brackets. According to Job Corps data, 1.9 million students have attended since the inception of the program, with 60,000 students served annually (Schochet et al, 1864). Job Corps services fall under four categories: Outreach and Admissions, Career Preparation Period, Career Development Period, and Career Transition Period. (Figure 5)

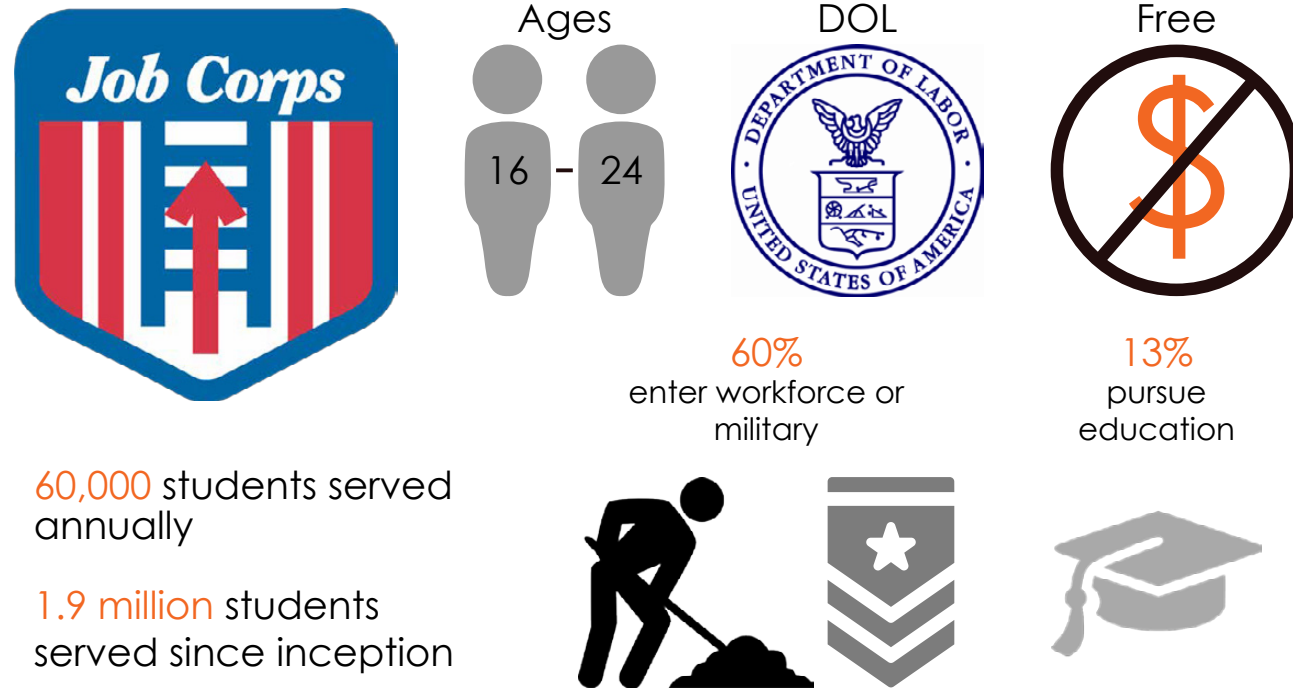

Figure 5 - Basic data for Job Corps infographic. Credit: Author.

In 2001, the Mathematica Policy Research organization conducted a comprehensive study on Job Corps that was funded by the U.S. Department of Labor. Among the key findings of the study are that Job Corp Centers deliver comprehensive and consistent services, and make a meaningful difference in the educational achievements and earnings of its students Also noted was the gains from Job Corps are found across most groups of students and types of settings, and that the value of benefits from the program exceed the program's costs (Burghardt et al, 3). Job Corps itself reports that they have been successful in terms of placing their students after training. Their 2008 Annual Report states that 64 percent joined the work force or entered in military service while another

Classroom



St. Louis Job Corps Center

Dining



San Jose Job Corps Center

Counseling



Alaska Job Corps Center

Health



Inland Empire Job Corps Center

Commons



Atterbury Job Corps Center

Dorms



Gary Job Corps Center

Figure 6 - Typical Job Corps program amenities.

14 percent enrolled in education (PY 08). (Figure 5)

Existing Job Corps centers across the United States typically serve between 200 and 2,600 students. The Job Corps Study authors write that “individual Job Corps centers – most serving between 200 and 700 students – are at the heart of the operation,” (Burghardt et al, 4). A majority of students also reside at the centers – 88 percent of students live on the grounds during their enrollment (Burghardt et al, 7). The study provides other important observations that have direct architectural implications. One of the unique features of Job Corps centers are the amenities offered on site. These features are what make it stand out from a traditional facility for Career and Technical Training. The Job Corps centers not only provide learning spaces and counseling and outreach offices but also dormitories and related amenities, like dining halls and physical activity spaces. (Figure 6) The individual centers are the nuclei of activity and ultimately what make the program a success. In recognition of the importance of their physical facilities, Job Corps has recently been putting more funds towards new buildings. Two recent examples of new facilities are the Potomac Job Corps Center and the New Hampshire Job Corps Center. Located in Washington, DC, the Potomac currently has two of its five planned phases under construction, designed by Cox Graae + Spack Architects. The Department of Labor has plans to make this center a “flagship center” Serving as a model for future Job Corp campuses. (Figures 7-9) The 25 acre New Hampshire Center, designed by Miller Dyer Spears, places a strong focus on campus layout, a refined material palette, and sustainable building methods. (Figures 10-12) Both of these projects demonstrate that Job Corps is investing money into the performance and aesthetic qualities of its physical facilities in order to provide a better environment for the students to learn.



Figure 7 - Potomac Job Corps exterior.
Credit: CGS Architects



Figure 8 - Potomac Job Corps exterior.
Credit: CGS Architects.



Figure 9 - Potomac Job Corps interior detailing and exterior. Credit: CGS Architects.

Job Corps centers offer a wide range of training services. Their over 100 programs can be classified within the sectors of advanced manufacturing, automotive and machine repair, construction, health care, homeland security, hospitality, finance and business, information technology, renewable energy, retail services and sales, and transportation. Several of these training categories coincide with strategic industries identified by Seattle's Office of Economic Development. The sectors noted to be important to the growth of the city are advanced manufacturing, health care, information technology, and renewable energy (Seattle Key Industries, data collected 05/2017). (Figures 13 & 14)

There are currently four Job Corps campuses in Washington state: Fort Simcoe in White Swan, Cascades in Sedro-Wooley, Columbia Basin in Moses Lake, and the Curlew campus in Curlew. (Figure 15) These are all sprawling campus complexes, with multiple buildings spread out on large properties. All of the campuses are also in rural areas. Figures 16 through 19 studies offer a more direct look at general campus layout. It also indicates proximity to the nearest town and to the major cities of Seattle or Spokane. There is clearly a need for a campus in the city of Seattle, to allow Job Corps to have a strong presence in the main economic hub of Washington.



Figure 10 - New Hampshire Job Corps campus layout.
Credit: Aerial Impressions.



Figure 11 - New Hampshire Job Corps exterior.
Credit: Chuck Choi.



Figure 12 - New Hampshire manufacturing learning space.
Credit: Chuck Choi.

LEARN TO WORK

THEORETICAL FRAMEWORK

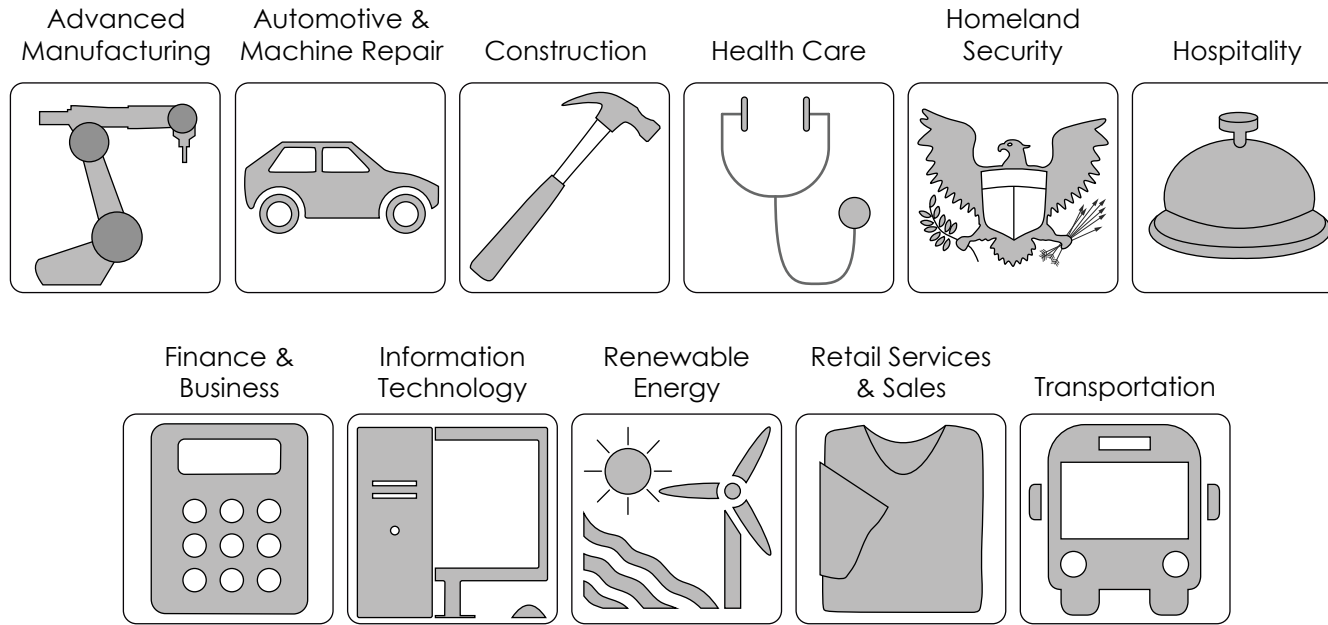

Figure 13 - Job Corps industry program focuses of study. Credit: Author, data from JobCorps.gov.

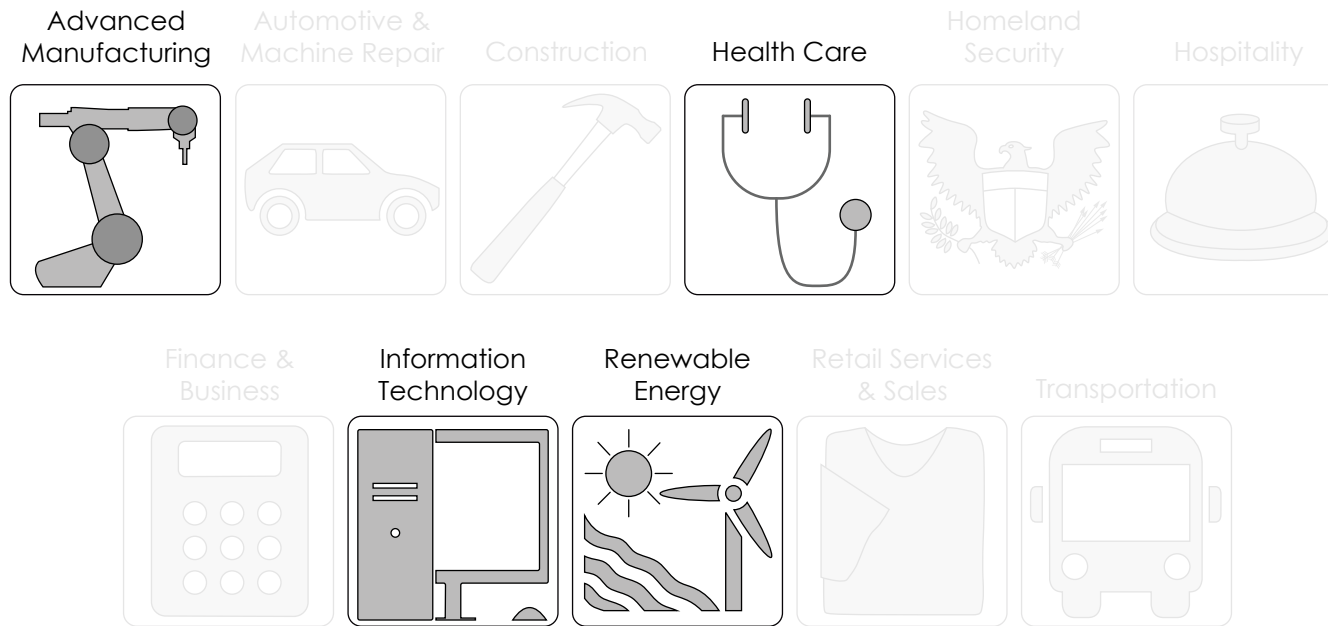

Figure 14 - Job Corps industry programs that align with the Seattle growing/healthy job markets. Credit: Author, data from Seattle's Office of Economic Development.

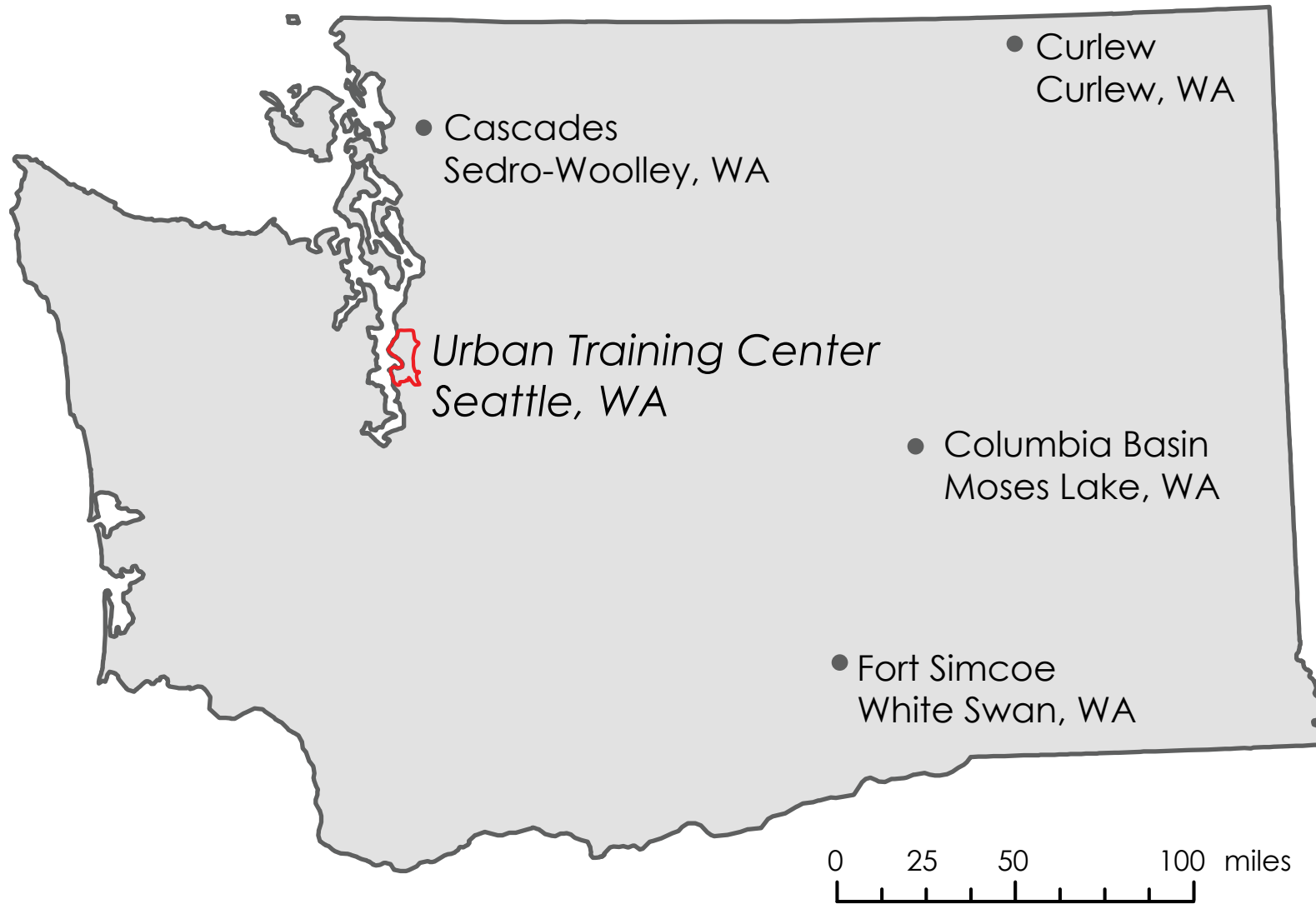

Figure 15 - Washington state Job Corps locations. Credit: Author, data from JobCorps.gov.



Figure 16 - Cascades Job Corps campus study. Credit: Author, background from Google Earth.

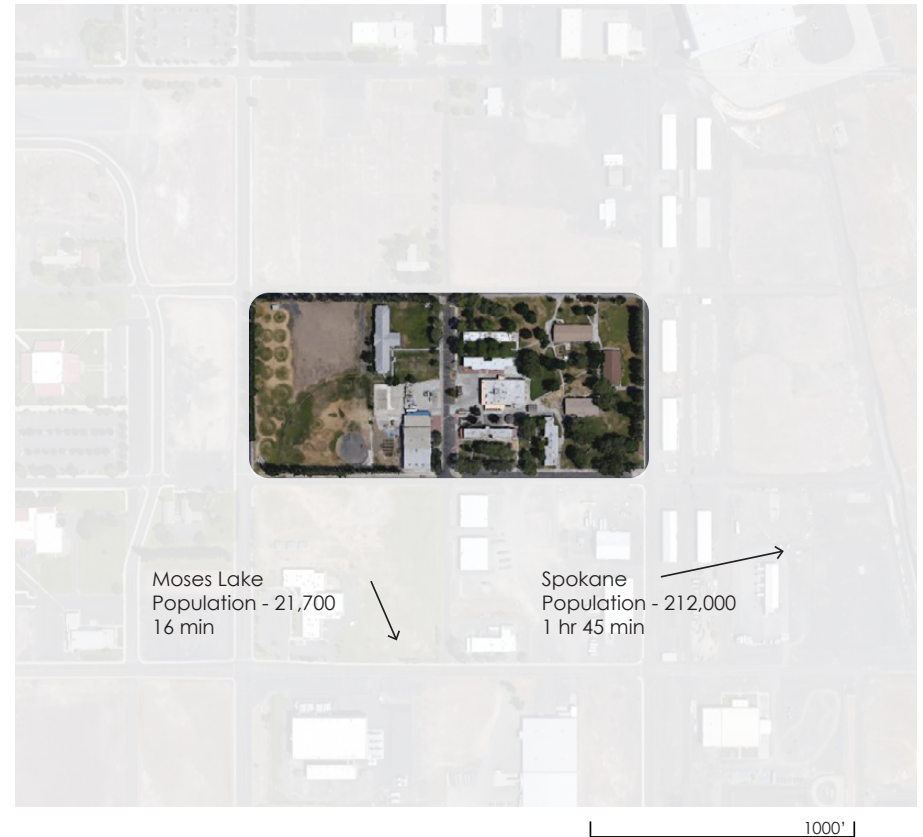

Figure 17 - Columbia Basin Job Corps campus study. Credit: Author, background from Google Earth.



Figure 18 - Curlew Job Corps Campus study. Credit: Author, background from Google Earth.



Figure 19 - Fort Simcoe Job Corps campus study. Credit: Author, background from Google Earth.

2.3 – Architecture of Existing CTE Programs

The architecture of the existing Job Corps facilities varies throughout the U.S., and in Washington State. While the programs have a consistent success rate across the country, the buildings are different in their age, condition and appearance. The question as to the efficacy of the existing buildings must begin with an understanding of how the physical environment can affect learning. In the anthology, *Learning Spaces*, Ken Graetz addresses the psychology of learning. He states “In any learning environment students are awash in environmental information, only a small fraction of which constitutes the sights and sounds of instruction,” (Graetz, 6.1). Graetz references the work of Stephen and Rachel Kaplan who propose “four cognitive determinants of environmental preference”:

- Coherence – the ease with which a setting can be organized cognitively
- Complexity – the perceived capacity of the setting to occupy interest and stimulate activity
- Legibility – the perceived ease of use
- Mystery – the perception that entering the setting would lead to increased learning, interaction, or interest. (Graetz, 6.11)

These principles characterize the ways in which a human comprehends the world around him or her and perceives their physical surroundings. The space that a person learns is especially important in shaping the experiences that can lead to inspiration and creativity. The authors of “Re-imagining the Modern Classroom,” state that certain qualities of the built environment can lead to



Figure 20 - Conceptual floor plan (above) compared to a traditional school floor plan (below). Credit: Parkhill, Smith and Cooper.

more active and engaging learning environments. These include spatial and environmental factors such as access to daylight, good air quality, views to green space (Graetz, 6.2), commons spaces, and diversity of spaces, both in function and size (Glatter, DeRuy, and Wong).

Past models of classrooms based on lecture format teaching fail to engage experiential education. This new type of classroom of a learning space encourages flexibility and interaction as shown in a conceptual floor plan by Parkhill, Smith and Cooper, a Texas based research and design firm. (Figure 20) The new model encourages engagement and adaptability to different students learning speeds and styles. This need is evident in the Superior Heights Collegiate and Vocational School in Sault Ste. Marie, Ontario, Canada, a 40 million dollar project. The designers, ZAS Architects have provided a diversity of spaces, but seemed to have neglected common spaces. (Figure 25) While the gym, cafeteria and library might be considered as shared spaces, they are already too established in their roles to act as agents of flexible common spaces. Another example is the historic Essex County Boys Vocational School built in 1930 (today known as Bloomfield Tech located in Bloomfield, NJ). (Figure 21) The first floor plan reveals clear delineation of spaces – auditorium, gymnasium, and spaces dedicated to specific services. While generally well designed, with diversity in uses and rooms, the angled form results in some odd irregular spaces. Like the Superior Heights project, the school lacks any kind of central gathering space to allow social interaction. Another historical example is the Fox Valley Technical Institute from 1912 in Oshkosh, WI. (Figures 22 & 23) The plan is characterized by double loaded corridors and poorly lit classrooms. No

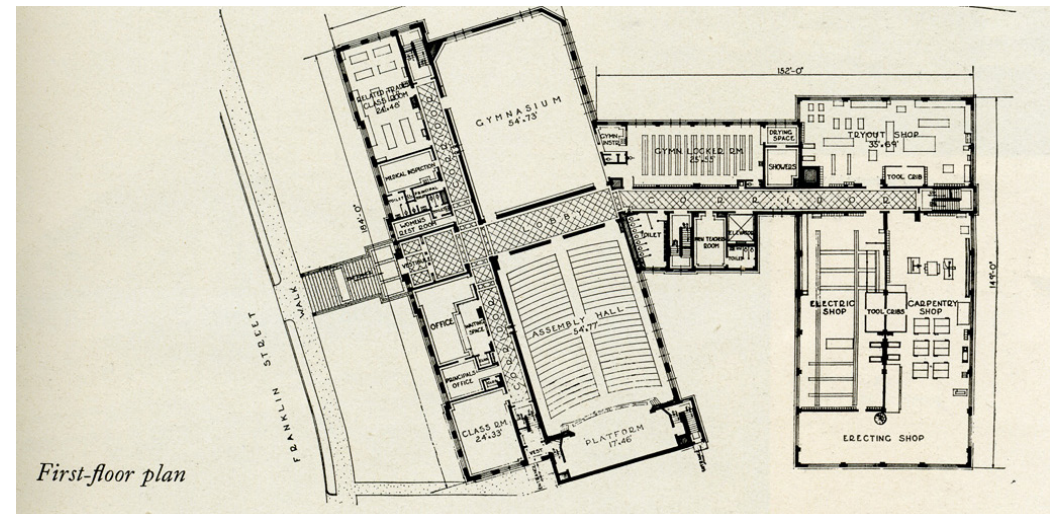

Figure 21 - Essex County Boys Vocational school first floor plan. Credit: Steve Weintraub.



Figure 22 - Fox Valley Tech Institute classroom. Credit: Library of Congress.



Figure 23 - Fox Valley Tech Institute corridor. Credit: Library of Congress.



Figure 24 - Clockwise, from top left: Cleveland Job Corps, St. Louis Job Corps, Los Angeles Job Corps, and Treasure Island Job Corps in San Francisco. Credit for all: Job Corps.

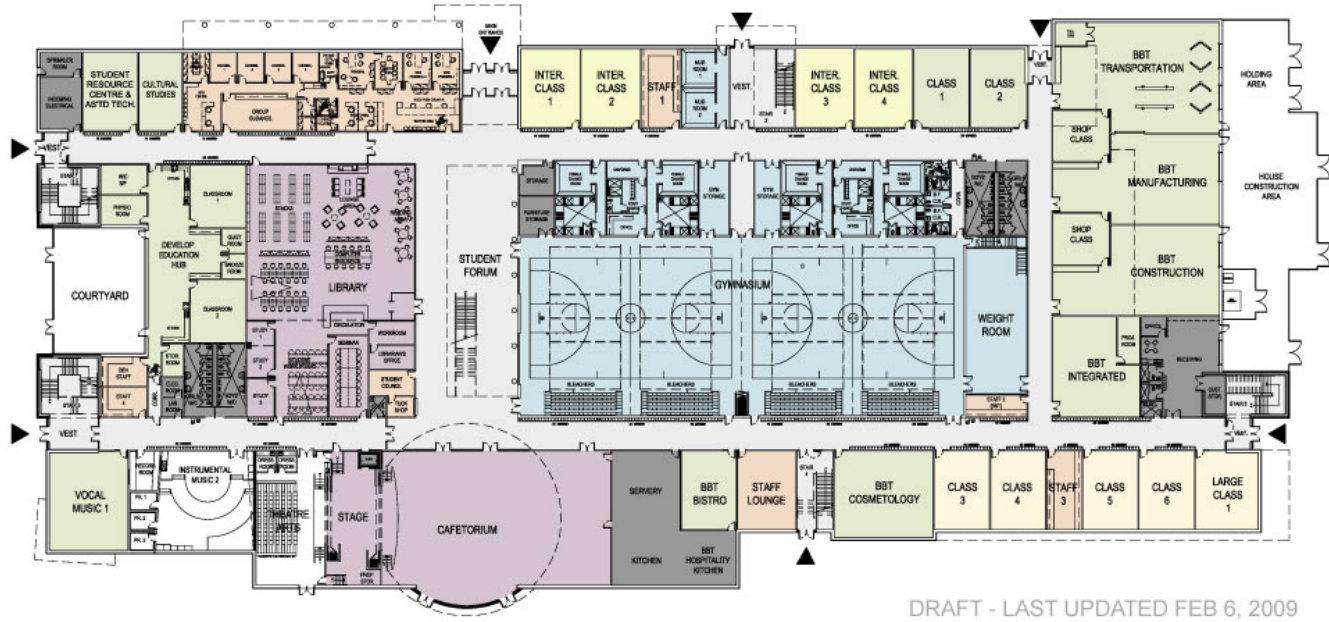
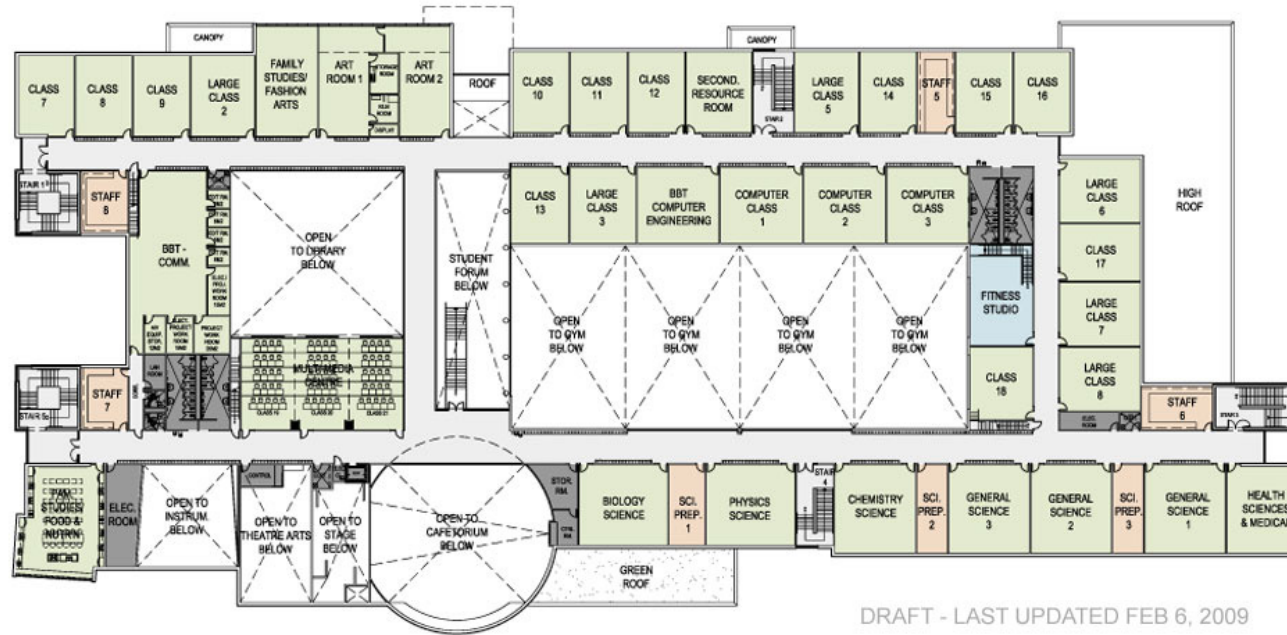

Figure 25 - Superior Heights School ground level (below) and upper level plan (above). Credit: Superior Heights.

longer in use as a school, it is currently used for civic functions associated with the city hall complex.

Existing Job Corps building provide additional examples of educational facilities that are in need of updating. The exterior of some of these projects fails to convey the importance of the educational activities inside. The Cleveland Job Corps building In Ohio, for example, evokes the image of a strip mall on the outskirts of a suburb, not the training of motivated young adults. The Treasure Island Job Corps building in San Francisco offers no indication of the social value of the institution. The monotonous flat facade with punched windows and barren concrete walls are more reminiscent of a prison than an educational center. The Los Angeles Job Corps addition was just completed in 2010 but appears much older from the exterior. There is a desirable inner courtyard available to the students as a communal space but the exterior gives the impression of a generic commercial office building. *(Figure 24)*

These examples of the physical facilities of Career and Training Programs are not providing the physical or psychological benefits that a that a learning center should have. Both interior and exterior should provide a gateway for young adults to learn and engage. Moving on from these lessons, the next chapter will study buildings that more successfully serve as the aim of active learning in their design. In its program and siting, the project seeks to address the skills gap through a comprehensive form of education that uses experiential learning techniques.

3. Precedents and Program Analysis

The following several pages will explore existing precedents that will be used as a launching pad for the Seattle Job Corps Magnet Program.

3.1 - Kawartha Trades and Technology Center.

3.2 - Jacobs Institute of Design Innovation

3.3 - Deakin Trade Training Centre.



Figure 26 - Kawartha Trades and Technology Center.
Credit: Scott Norsworthy.



Figure 27 - Jacobs Institute of Design Innovation.
Credit: Tim Griffith.



Figure 28 - Deakin Trade Training Centre.
Credit: Zachary Couyant.

3.1 – Kawartha Trades and Technology Centre

Firm: Perkins + Will

Year Completed: 2014

Size: 87,000 sq ft

Location: Peterborough, Ontario, Canada

Kawartha Trades and Technology Centre sits in a place of prominence on the campus of Fleming College in Peterborough in Ontario, Canada. The project was designed by the Toronto office of Perkins + Will who conceived of the building as a gateway between the campus proper and the surrounding world. Within the 87,000 square foot building, space is provided for training in carpentry, welding, plumbing and machining. The architects sought to use the project as an opportunity to raise interest in the skilled trades by reinterpreting the typical campus building. The two main visual focal points of the project are the entry with its oversized “awning” and the interior Learning Factory space that encourages the cross pollination of different trade sectors. The building itself was loosely inspired by the idea of “industry”, expressed in exposed structure and raw building materials. Multi-level vision is encouraged through large and flexible spaces. The success of the community role of the building is evident in the middle school camp called “Tech it Out” that was held there in the spring of 2017 (Explore Fleming).



Figure 29 - Entry canopy. Credit: Tom Arban.



Figure 30 - Learning Factory. Credit: Scott Norsworthy.

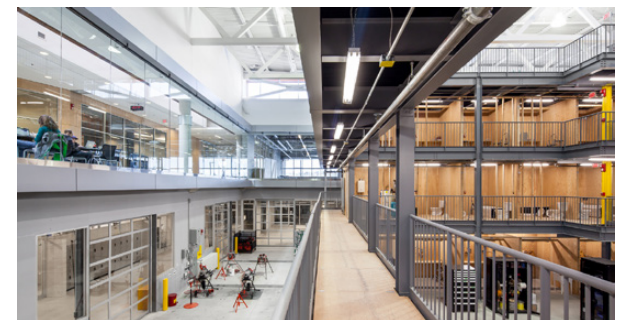
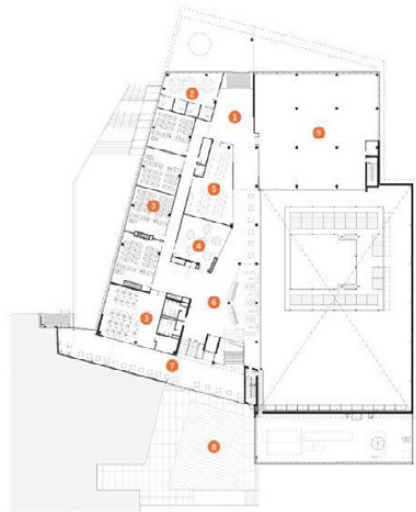
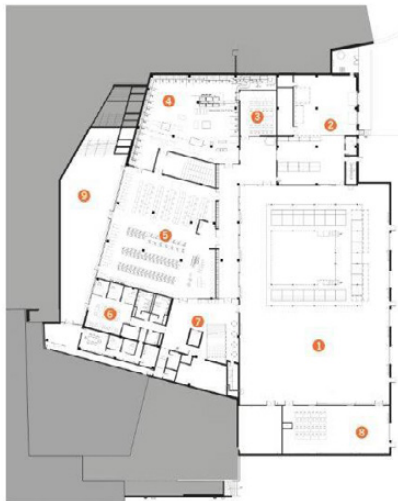

Figure 31 - Catwalk along Teaching Cube. Credit: Scott Norsworthy.



GROUND LEVEL

- 1. Entry Lobby
- 2. Office Area
- 3. Classrooms
- 4. Corporate Classroom
- 5. Engineering Commons
- 6. "Oasis" Space
- 7. Campus Link
- 8. Terrace
- 9. Project Space



LOWER LEVEL

- 1. Learning Factory
- 2. Shipping / Receiving
- 3. Welding Workshop
- 4. Welding, Mach, Fabrication
- 5. Gas/Oil/HVAC Workshop
- 6. Office Area
- 7. Lower Lobby
- 8. Carpentry
- 9. Teaching Court

Figure 32 - Upper level (above) and lower level (below) plans. Credit: Perkins+Will.

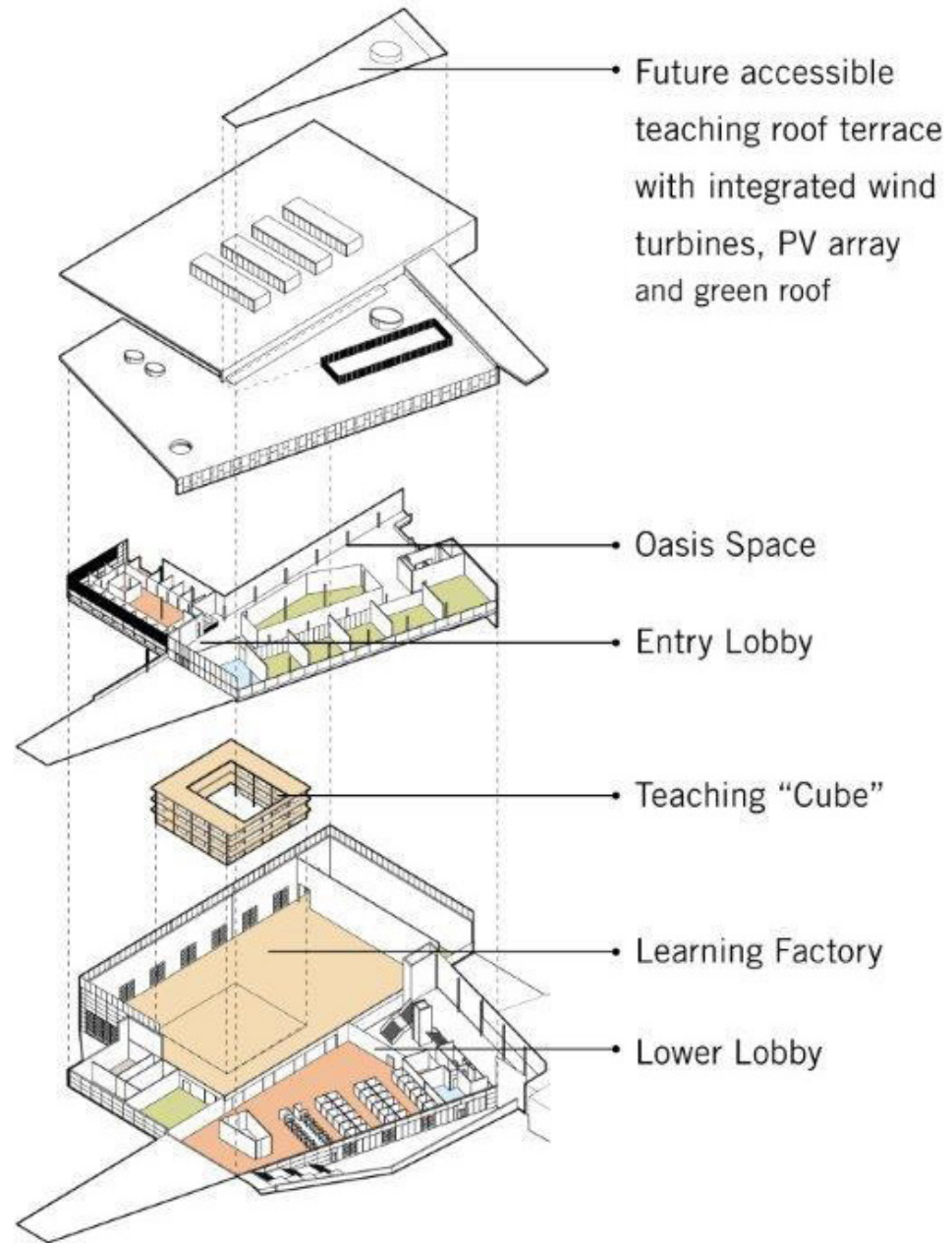

Figure 33 - Axonometric program diagram. Credit: Perkins+Will.

3.2 – *Jacobs Institute of Design Innovation, UC Berkeley*

Firm: Leddy Maytum Stacey Architects

Year Completed: 2015

Size: 24,000 sq ft

Location: Berkeley, CA

While the Jacobs Institute of Design supports a different kind of program, it is nevertheless relevant to this thesis. Part of the University of California Berkeley campus, the Jacobs Institute is run by the College of Engineering and is located a few blocks off from campus proper in a more urban setting. Leddy Maytum Stacey Architects sought to offer an educational space that provided flexible space for team based projects. The building seeks to inspire collaboration from students, student groups, and faculty from across the entire campus. A transparent ground level facade helps to connect the building and its activities with passing pedestrians. In place of traditional classrooms, the school has studios, the largest able to act as an exhibition or gallery space. All of the studios are surrounded by several smaller lounge areas. Within a fairly small building of 24,000 square feet, the architects have designed well-lit and generous flexible spaces that focus on collaboration and innovation.



Figure 34 - Exterior. Credit: Tim Griffith.

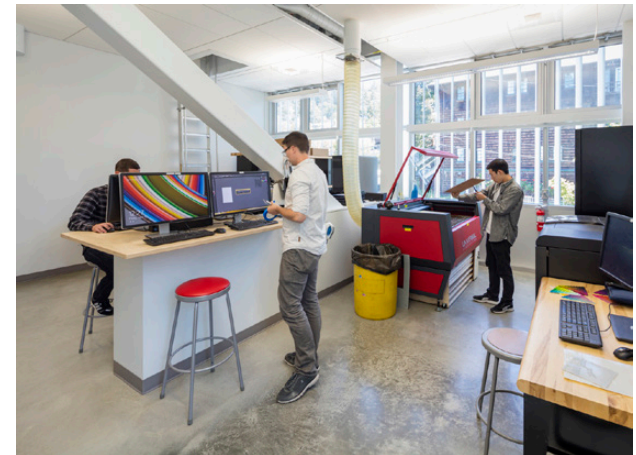

Figure 35 - Classroom. Credit: Tim Griffith.

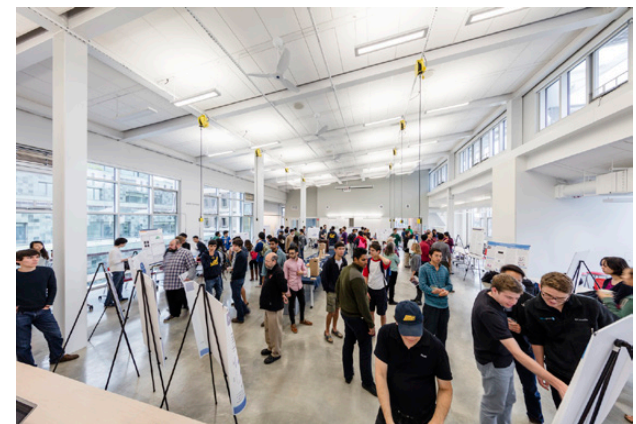

Figure 36 - Gallery Space. Credit: Tim Griffith.

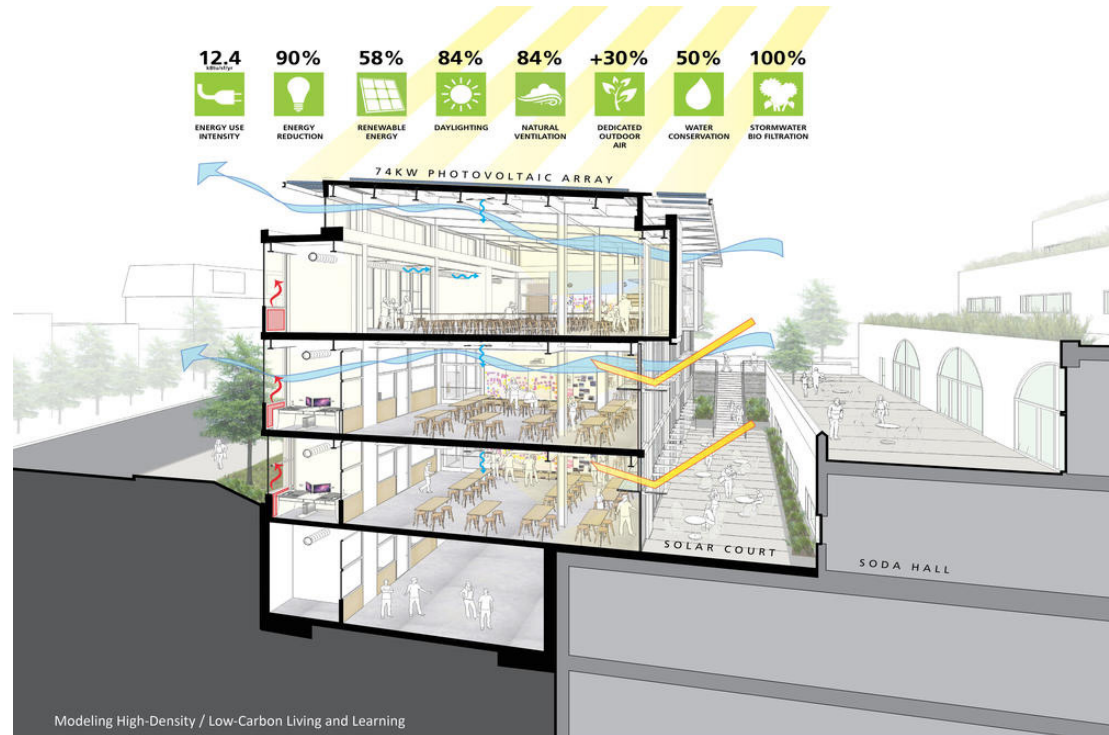
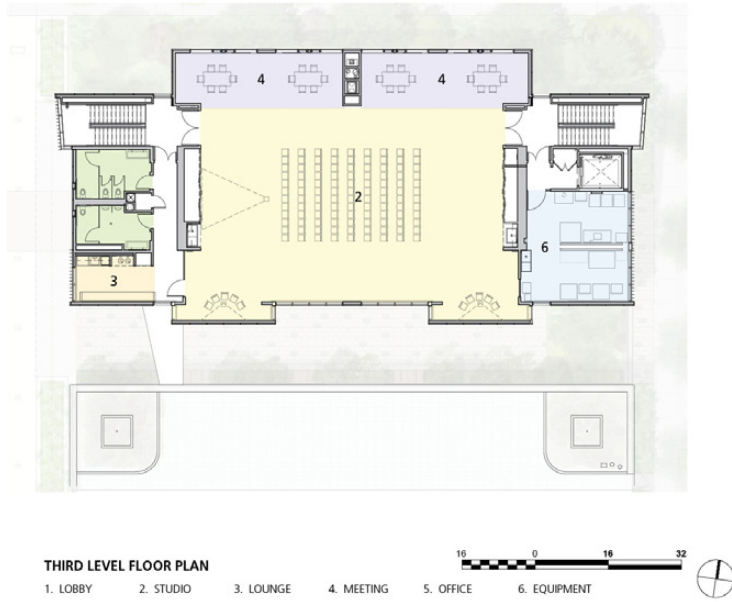

Figure 38 - Section Perspective with Design Elements. Credit: LMS Architects.

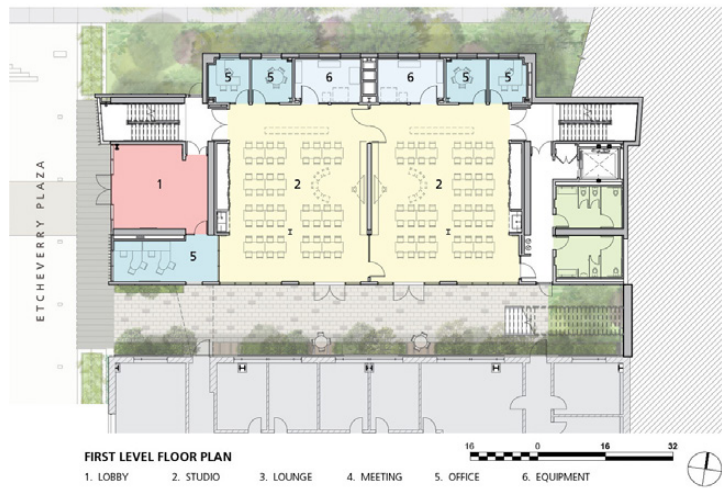

Figure 37 - Floor plans. Credit: LMS Architects.

3.3 – Deakin Trade Training Centre

Firm: Y2 Architects

Year Completed: 2014

Size: 87,000 sq ft

Location: Peterborough, Ontario, Canada

The Deakin Trade Training Centre provides specialized training for young adults in Mildura, a town in Victoria, Australia. It is part of the Mildura Senior College, which provides optional schooling for students in their final years of high school who wish to pursue a vocation. Designed by Y2 Architecture, the building is covered with bold colored exterior panels and clear wayfinding that directs students to the center volume of the school where cross-disciplinary interaction between the trades is encouraged. The form is derived from historically local shearers sheds while looking to the future with modern layout and materials. The building as a whole makes a statement with the brightly colored façade treatment. The central volume provides sight lines to all of the flexible training spaces to further encourage engagement between the students. The training currently covers building and construction, furniture and cabinet making, engineering, automotive, electro technology, avionics and hospitality. The facility expresses the belief of the college that training in these trades is important and can fulfill local labor demands.



Figure 39 - Exterior facade. Credit: Zachary Couyant.



Figure 40 - Circulation. Credit: Zachary Couyant.



Figure 41 - Classroom. Credit: Zachary Couyant.

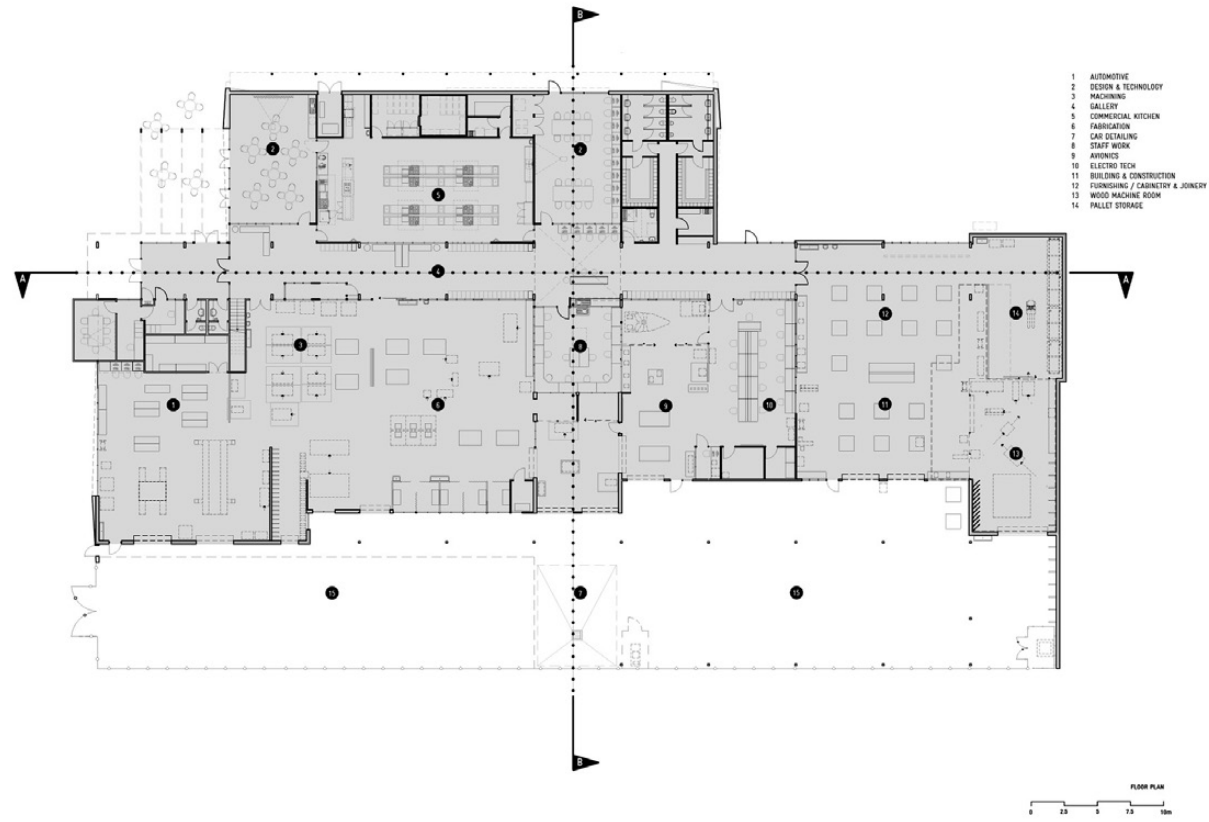

Figure 42 - Ground level floor plan. Credit: Y2 Architects.

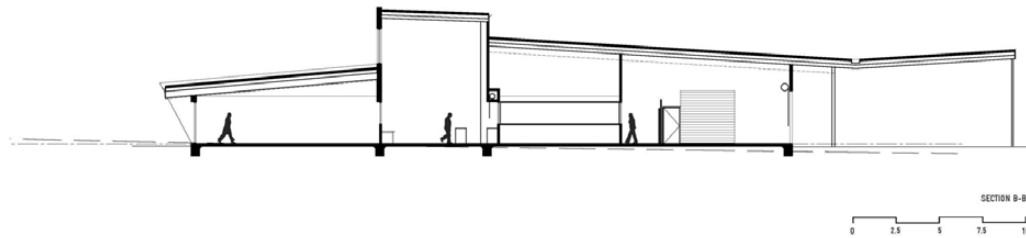

Figure 43 - Section. Credit: Y2 Architects.

4. Methods

This chapter will define the goals for the design intervention, explore the neighborhood and site selection, and finally the program proposal. The methods of the thesis will establish the criteria for the choice of the site and the development of the program of the New Job Corp Center for Seattle.

4.1 – Goals

1. Provide an engaging and flexible place of learning.
By designing a building that allows students to engage in an experiential form of learning, they will grow as individuals while honing a craft and passion for a skill that can allow them to earn a living. The space must be flexible enough to allow for future change but also meet the demands of current conditions. It should be able to adapt to changing technologies but should also maintain the qualities that have been to lead to better educational outcomes – quality light, quality air, and views to the outside (Graetz, 6.2).
2. Offer a space of innovation where students can engage with professionals.
By implementing an innovation space, students can engage with potential employers or mentors, run pop-up shops that might celebrate their own work, or allow for a space where community engagement can occur.
3. Have a space that can help gain recognition for the value of skilled labor.
A building can provide an identity. The goal for the Seattle Job Corps

Magnet program is to offer a building that makes a declarative statement about the value of the education within and sets up young adults for making a livelihood through a skilled labor. This center will provide an education available to young adults from all walks of life and be a place that the occupants will be proud of.

4.2 – Neighborhood and Site Selection

This section will establish the criteria for the choice of the site and the development of the program of the New Job Corp Center for Seattle. The main factors for the neighborhood selection are as follows: relatively close to major public transit and work related facilities, and have a connection to, but some distance from, other young adult services or programs. (Figures 44 & 45)

In order to best serve the community and allow for the programs to flourish, the intent is that the Job Corps center will maintain some kind of geographic separation from existing young adult programs. To root the project firmly in its environment, it would be beneficial to site the building in a neighborhood that has some historical or current roots in the industries of industry/ manufacturing, health sciences, and/

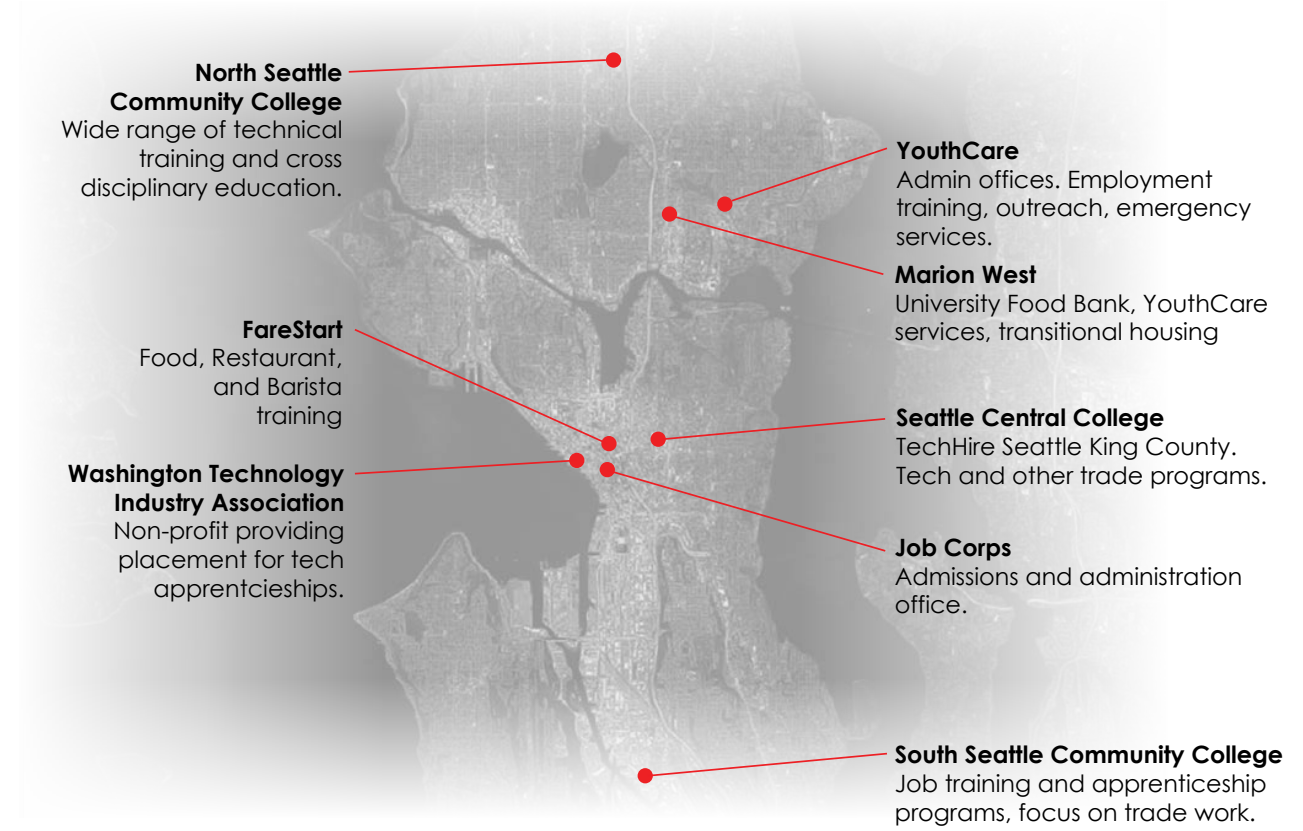

Figure 44 - Existing Young Adult Programs. Credit: Author.

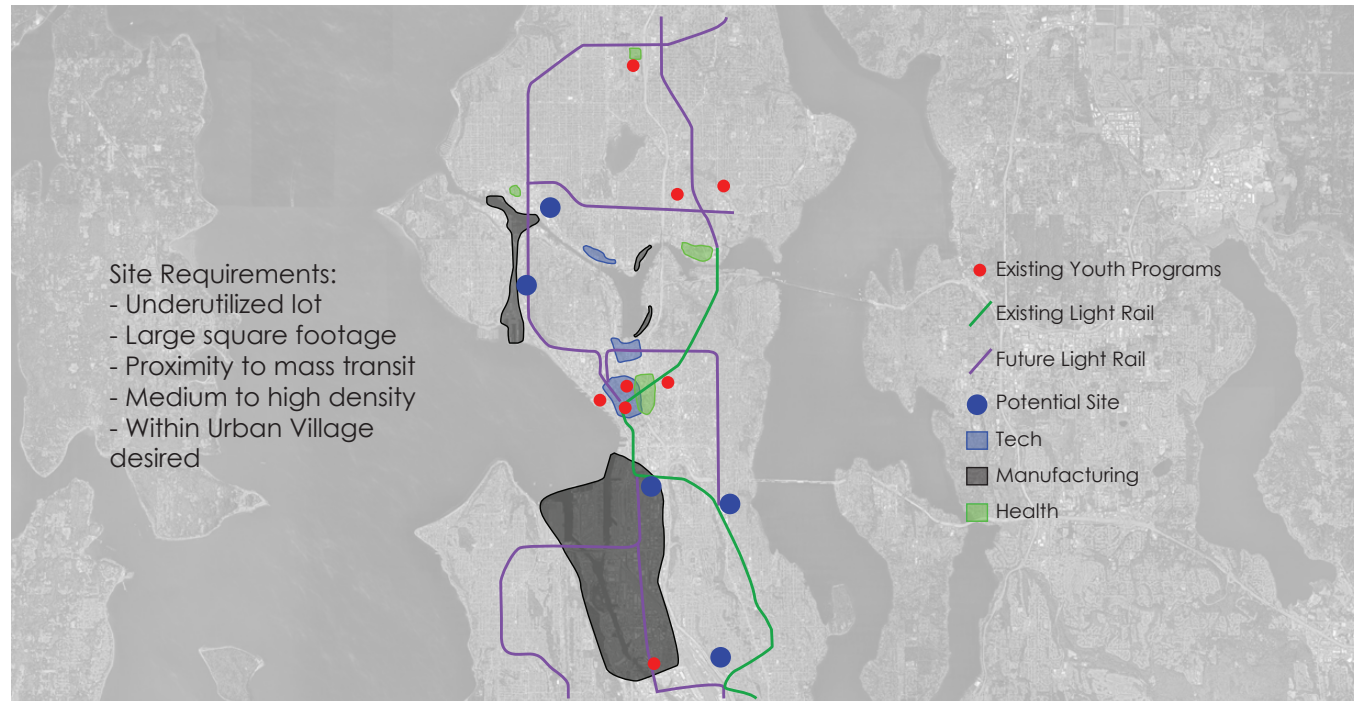

Figure 45 - Potential Site Considerations. Credit: Author.

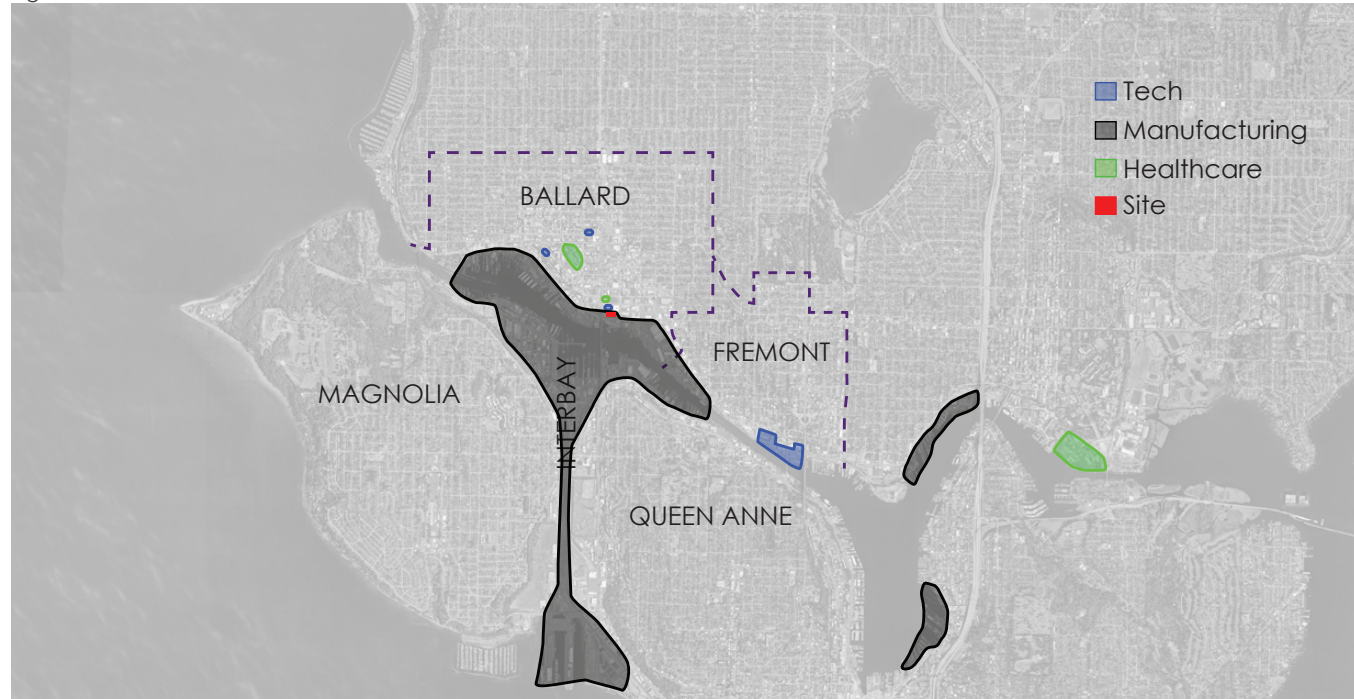

Figure 46 - Greater site context. Credit: Author.

or technology. Proximity to one or all of these job sectors would be desirable. The site should be easily accessible to all, a 5 minute walk of a major mode of public transportation. Finally, the use of a vacant or underutilized lot is desirable. With all of these considerations, one neighborhood that satisfies all of these requirements is the space between Ballard and Fremont, popularly known as the “Frelard” area. (*Figure 46*)

Frelard is an interstitial space between two popular neighborhoods with a strong history of industry that continues to this day. The waterfront continues to be heavily industrialized. The export of goods, primarily lumber and wood was responsible for the original development of the Ballard neighborhood. Eventually, fishing and marine industry became a major component of the waterfront. While manufacturing is not the main economic producer of the area it once was, it still holds value for the residents (Ballard Historical Society). Several pockets of high tech business have popped up in the last decade, primarily on the north side of the Fremont Cut, just west of the Fremont Bridge. Notable names like Tableau, Google, Adobe, Getty Images, and McNeel and Associates inhabit the Fremont neighborhood, along with several smaller technology companies as well in the Ballard area. Finally, there is a large health services complex with the Swedish Medical Center in Ballard, resulting in a fluid mix of tech and industry in the area. Frelard itself is more of a colloquial term for the stretch of Leary Way NW that connects 15th Ave NW and N 36th St. It is primarily commercial and restaurants along Leary Way, industrial along the waterfront, and residential north and east of Leary Way.

There is currently a vacant lot bordered to the north and south by NW 46th Street and NW 45th Street and to the east and west by 14th Ave NW and 15th Ave NW. Being directly within the Frelard area, the site is very close to all of the relevant industries. There are no community colleges or other young adult services

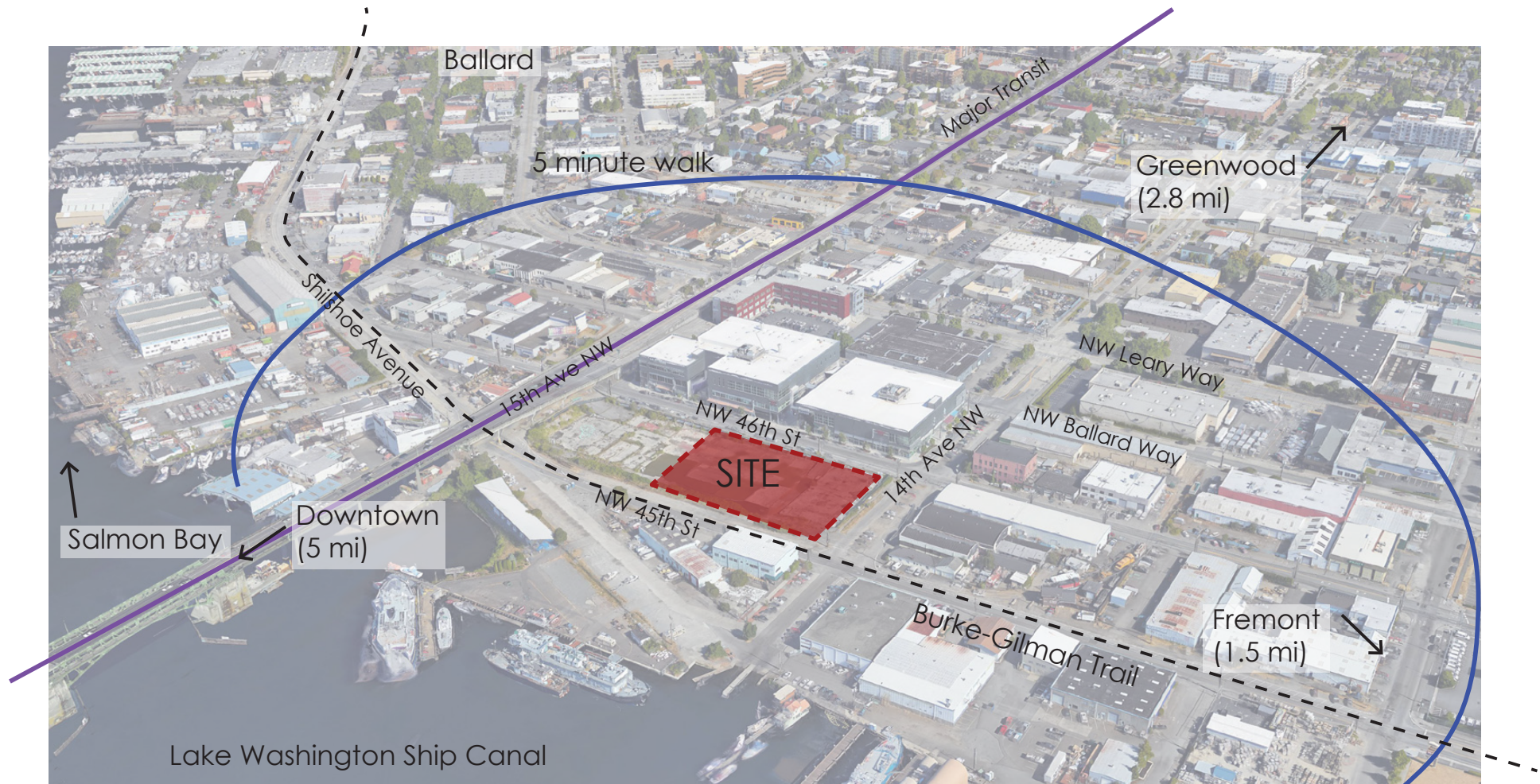

Figure 47 - Direct site context. Credit: Author.

which offer similar services in the immediate area to compete. To the south, the Burke-Gilman trail passes the site, offering a “pedestrian highway” for easy bike or walking access to students but also the potential for a very visible building landmark. For further travel purposes, the site is on the route of the current D-Line, a major north-south mode of bus travel in the city and the route of the future light rail. This site satisfies all the stated goals for the project location. Next, this thesis will turn to look at the program that will fill the site with life. (Figure 47)

4.3 –Proposed Program

The program for the proposed center for career and technical education will be based on that of existing Job Corp facilities. However it is important that the program of spaces also respond to the particular needs of the Seattle magnet program. The amenities provided by Job Corps always includes the following: classrooms, dorms, cafeteria, mentoring/counseling center, gym or other health facilities, community and common spaces. Typically large campuses, the four Washington Job Corps locations are located outside of major cities. As a result, the campuses are usually sprawling and cover a large amount of land. For example, the Cascades campus in Sedro-Wooley, WA covers 1.8 million square acres or 41 acres of land. In comparison, the more urban Los Angeles Job Corps covers an estimated 4 square city blocks, is roughly equivalent to 228,690 square feet. It is important to note that the Los Angeles Job Corps shares facilities and resources with a YWCA chapter. The proposed Seattle magnet program will cover around 120,000 square feet. (Figures 49 & 50)

The main components of the Seattle magnet program are defined by Outreach, Career Preparation & Development and Student Life. Most of the main functions of Job Corps facility will be kept – student dorms, cafeteria, common spaces and a counseling center. The Seattle Magnet program will include three main additions, a large lab or Discovery Lab and an Innovation Center. In addition the center will specialize in only one type of training in the field of additive manufacturing or 3D printing. This is an emerging technology that merges three of Seattle's emerging industries – health, manufacturing, and technology. (Figure 48) In order to support this type of training, the center will not contain traditional lecture style class rooms. Instead the Discovery Workshop will function

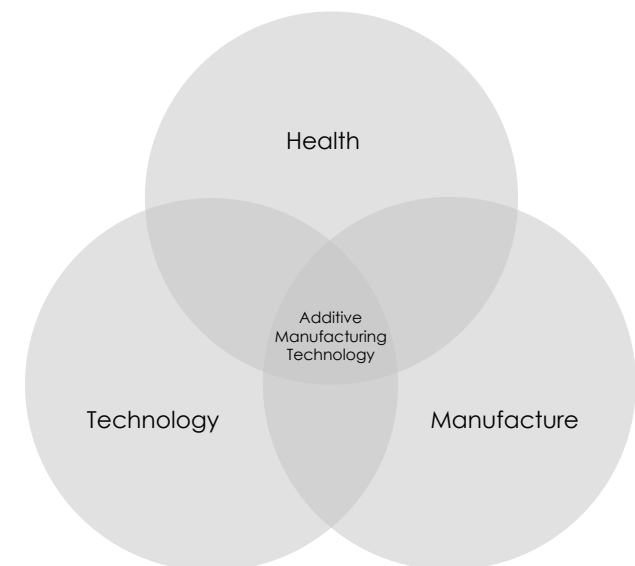

Figure 48 - Venn diagram showing the connection between Additive Manufacturing Technology and the three industry sectors that align with Seattle's Key Industries. Credit: Author.



Figure 49 - Washington Job Corps locations. Credit: Author, data from Job Corps.

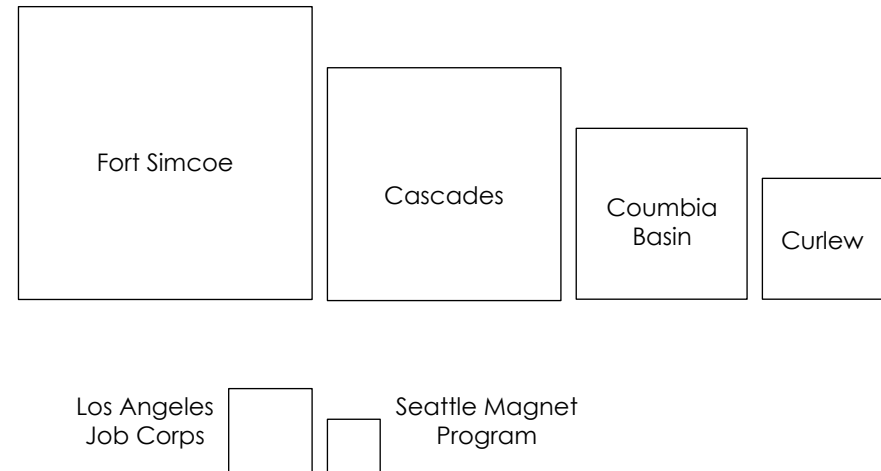

Figure 50 - Job Corps campus size comparison to scale.

as the primary learning center with smaller attached learning spaces. The workshop will be a large, flexible, and industrial space that will allow for changes to future program needs. The primary method of education will be through experiential hands on learning in the Workshop. The addition of the Innovation center will serve primarily as a mixing ground for the students and the outside world. Drawing from the experiences of the Jacob's Institute, this will be place of cross-pollination for students, professionals, and the community. (Figure 51)

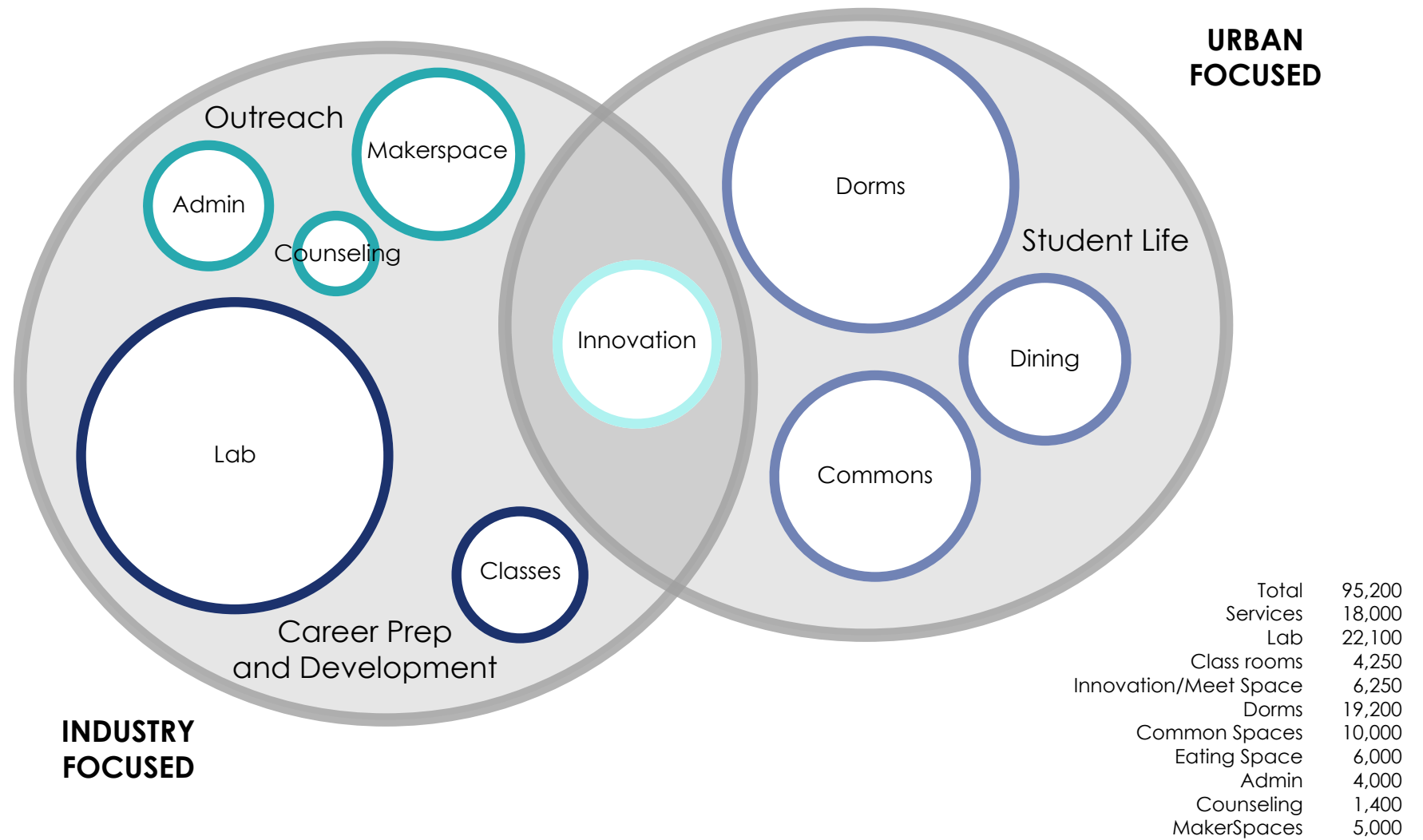

Figure 51 - Program proposal diagram. Credit: Author.

5. Site Analysis

Over the next few pages, the site and its surroundings will be explored in its present use through photographs, maps, and text. The site is located in what is technically the Ballard neighborhood but is in the transitional space between the Ballard and Fremont neighborhoods. It is a place of recent change and slow growth. The area is largely maintained as industrial, especially along the waterfront. The Ballard Blocks development just north of the site was completed in 2008 and is the largest development in the vicinity. This block holds retail, gyms, and office spaces. The newest building is the addition to the Seattle Maritime Academy completed in the summer of 2016 (outlined on map, *Figure 52*). The site zoning breaks down as follows:

- IG2 (General Industrial 2)
- FAR: 2.5
- Height: 65' (for institution use)
- Setbacks; May be required in some situations
- Max size of use limits: Up to 25,000 SF
- Several exceptions would apply due to the proposed program's institutional use designation.

The site previously held several large industrial buildings which were demolished between 2007 and 2008 in preparation for a commercial building to be constructed. Construction did not move past the permitting stage and as a result the site has sat vacant since the demolition. The lot sits at an interesting intersection between several popular neighborhoods and as was noted in the site selection has the D-line bus traveling north south along 15th and the Burke-



Figure 52 - Immediately adjacent businesses and items of note. Credit: Author, background: Google Earth.



Figure 53 - Site plan showing 5 minute walk and sun studies. Credit: Author, background: Google Earth.

Gilman trail traveling east-west along NW 45th St just south of the site. There is plenty of character on the site. The Ballard Terminal Railroad still runs one train servicing industrial shipments from Shilshole Yard to Salmon Bay Sand and Gravel, the train's sole customer. Below are several images that indicate the personality of the site.



Figure 54 - Left: The "Up" House, Edith Macefield's previous home that served as the inspiration for the popular animated movie, "Up". Left to right, top to bottom: Mike's Tavern, this bar and the "Up" house kept large masses from the Ballard Blocks. Live-aboard RV's are common along the block. Sign along the Burke-Gilman. View of the 15th Ave NW overpass. An old SDCI Notice of Proposed Land Use Action board. Another sign along the Burke-Gilman trail. Rail tracks for the Ballard Terminal Railroad. Credit for all images: Author.

The site has an intimate connection to the water, via the area's history and immediate vicinity to the Lake Washington Ship Canal and Salmon bay. As a result, the materiality of the area is industrial and marine focused, where corrugated metal and heavy timber docks with concrete platforms are prevalent. Some exploration of utilizing 3-d printing to define space or as a tertiary building material may be explored as a way to tie in the future program with the historical integrity of the site. The prominent materials of the area will be used as influencing factors in the definition of the building.

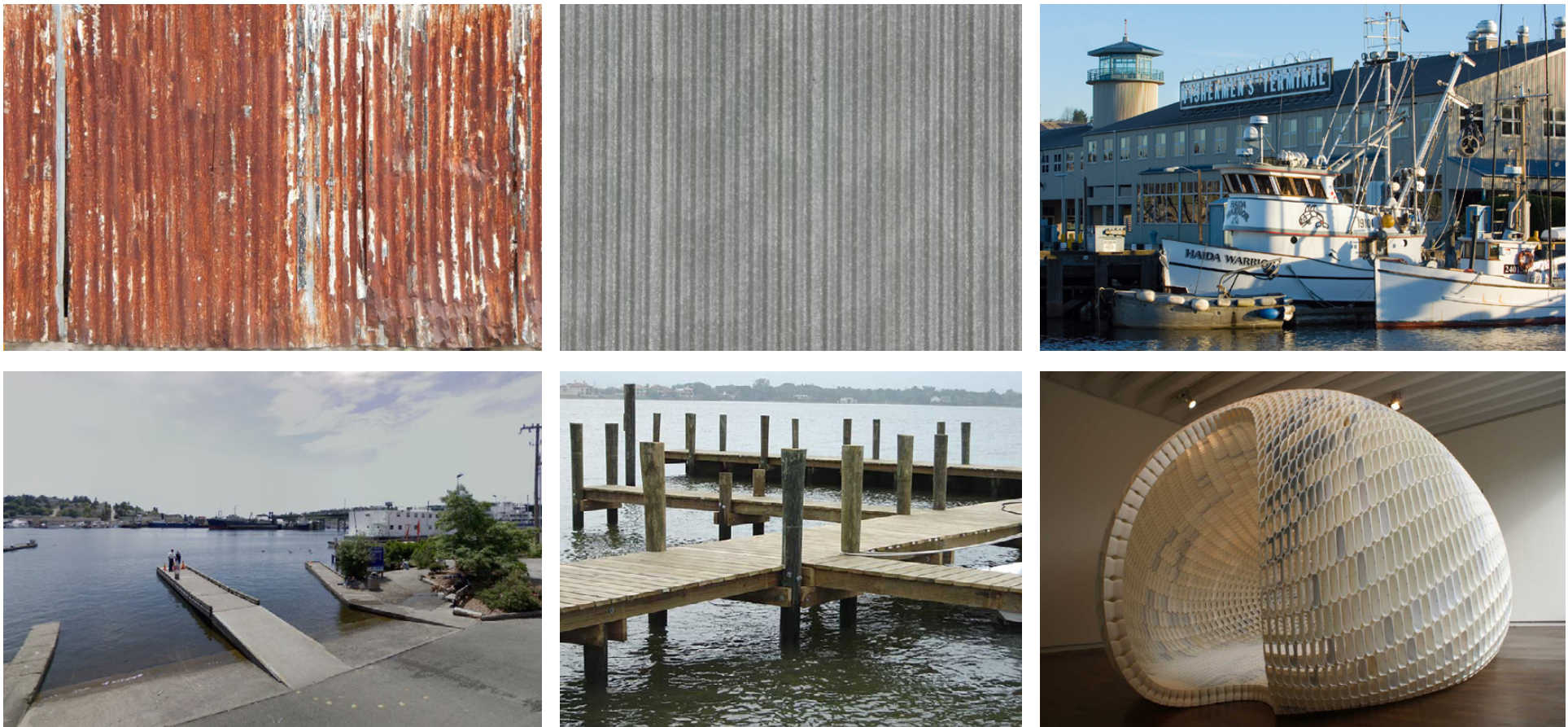
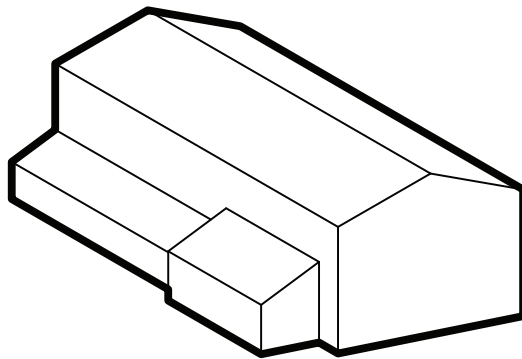

Figure 55 - Material images for the site. Clockwise, starting from top left: Rusted corrugated metal, credit: lughertexture.com; Corrugated metal, credit: Jupiterimages/Photos.com; Fisherman's Terminal in Salmon Bay, credit: Port of Seattle; 14th Ave Boat Ramp, credit: Google Earth; Wooden dock, credit: sweetwaterstyle.blogspot.com; 3-D printed art, credit: projectEGG.org

6. Design Response

6.1 – Concept of Design

The design of the school will stem from three main factors: the industrial fabric of the Ballard waterfront, the idea that collaboration between students and the world outside of school will be the fulcrum of the space, and the model of career and technical education (*Figure 56*). Through study of the rich history of CTE schools in the United States, flexibility of space will be an important quality. In the future, the school may need to change as technology changes and the needs for additive manufacturing progresses.



Industrial Ballard

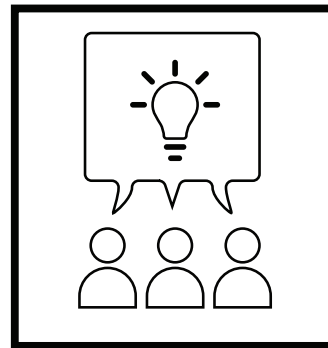

Collaboration

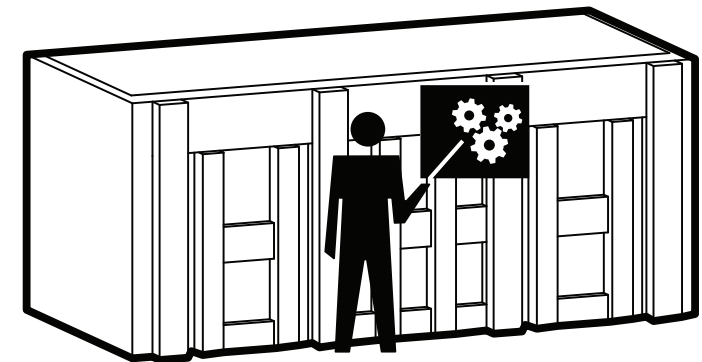

Career and Technical Education

Figure 56 - Design Concept Diagram. These three influencing factors will determine the design of the school: the industrial fabric of the Ballard waterfront, the idea that collaboration between students and the outside world will be a crucial factor in the success of the school and utilizing the model of career and technical education. Credit: Author.

6.2 – Final Design

The development of the design progresses over six moves (*Figure 57*). The first step was to understand the site and give the building the ability to hold the urban edges which relate the adjacent buildings to the north and east. The next was to take the three major program elements - the Lab, Innovation, and class/admin space - and give them definition. The Innovation space is to

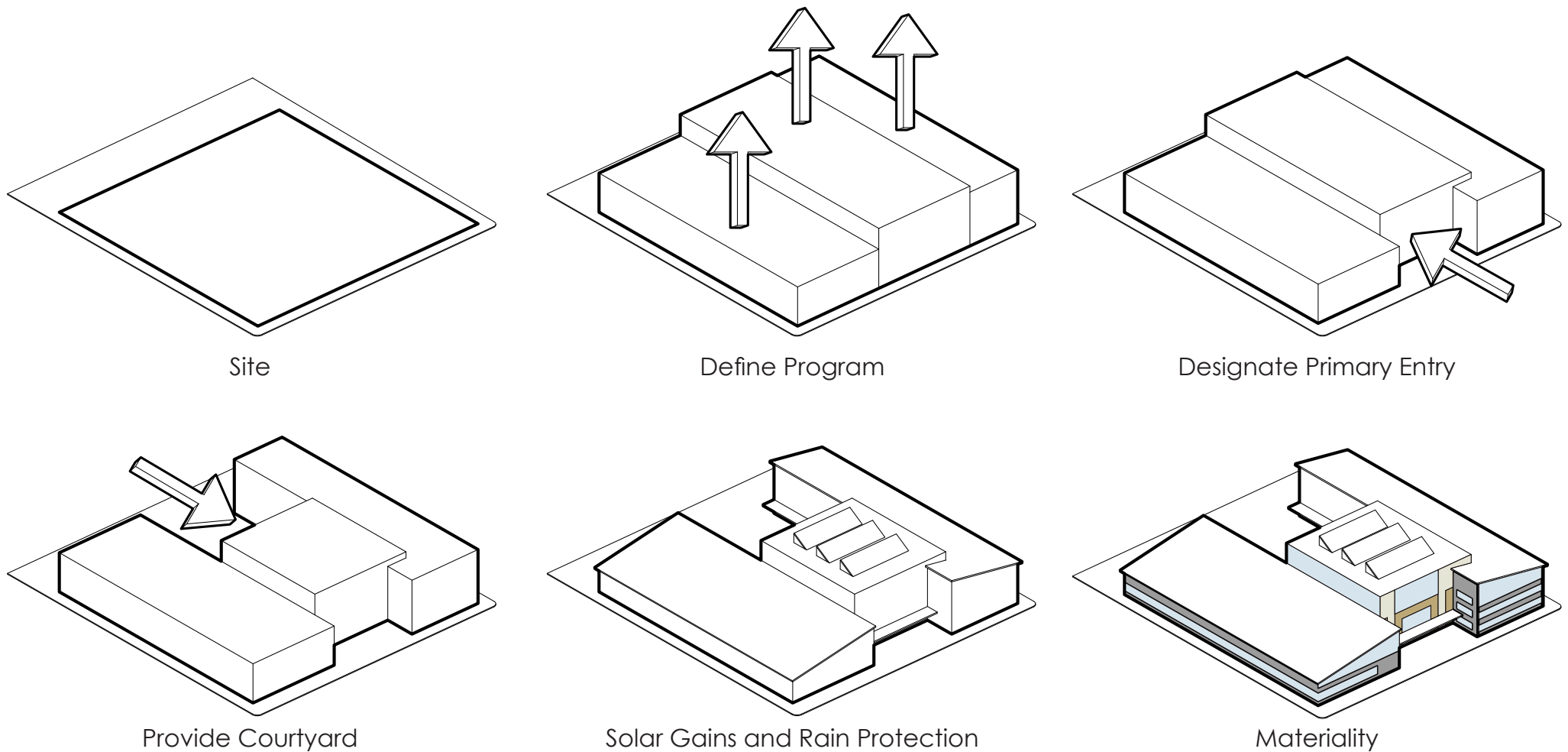

Figure 57 - The massing is developed over six steps. Credit: Author.

be the central feature of the building. The student and admin space would require multiple levels and will face the more urban side of the site. The Lab will have a viewing platform and double height space for working and will be industry facing so it reaches out to the south and the waterfront where industry is happening. The third move was to push the Innovation space in, allowing the Lab and class/admin to wrap around and making a primary entry. The fourth step pushes the Innovation space in from the west, which provides an outdoor courtyard. The next step is to allow for solar gains. This comes in the form of roof top monitors opening to the west on top of the Innovation space which will allow for a diffused light to fill the space. There are also clerestory windows on the north and south facades allowing for both direct and indirect light to enter the space. Sloping the roofs to Lab and the class/admin portions of the building allows integration of the industrial fabric and precipitation run off. Fenestration will sit atop 2'-6" stem walls with 8'-0" head height allowing for a high level of transparency at the pedestrian level. This encourages both natural daylight coming in as well as clear visibility between passersby and the students at work. The material application is further informed by the industrial fabric - vertical spanning metal siding will be the primary facade treatment. The structural logic will be glu-lam beam and post in reference to the piers of the nearby docks. In order to allow the Innovation space to be light-filled but still allow for reasonable amounts thermal insulation, recycled polycarbonate panels will clad the innovation space as well as a wood paneled system to give an indication of the interior structure method.

How the building fits in to the fabric of the neighborhood is also an important factor. The defining factors of the site are the urban character just north, the historic industrial texture to the east and south, and the 15th Ave overpass to the east. The school's primary entry will face 14th Ave NW where pedestrian and

vehicle traffic may be more prevalent. This will also allow easy access from the Burke-Gilman Trail. Figure 58 shows an aerial rendering of how the building will fill in the block and how it fits in with the surrounding neighborhood.

Early in the design process, it became apparent that the two major

Aerial Rendering



Figure 58 - Aerial rendering showing the Job Corps facility and the adjacent housing massing to the west.

programmatic elements of student life and working were best suited as two separate buildings. This helped fill out what would have otherwise been an empty half of the site and allowed for the development of a more campus style scheme that is consistent with other Job Corps programs. The majority of exploration and design occurred for the school building itself while the housing has been developed as a massing. It is a six story building that maxes out the sixty-five foot height limit on the site. On the first level of the housing component is student commons, dining, lobby, study spaces, and retail along the north wall. The intent is that the housing hold students on the second and third levels and above that is pro-rated housing for educators and otherwise market rate housing for a total of 220 rooms. Levels two and three will have two bed dorms, allowing housing for 196 students. Levels four and five would allow housing for forty three units per floor and level six would allow housing for another thirty six units. Each unit is 343 square feet allowing for a comfortably sized open 1 bed style or studio style apartment.

Housing Massing Breakdown		
Ground	Amenities	
Student Dorms		
Level 2	52 units	104 students
Level 3	46 units	92 students
Educator and Market Rate Housing		
Level 4	43 units	
Level 5	43 units	
Level 6	36 units	

The housing complex will be larger and more dense in response to the urban focused programmatic elements that inhabit the building. The school then will be more industrial focused and will be scaled appropriately. Figure 59 shows a rendering from the perspective of NW 45th St and 14th Ave NW, looking down the Burke-Gilman Trail. This view shows the school in the foreground and the housing massing in the background. The column grid sets up the window bays with windows at human scale allowing for light to come in to the building and views from the pedestrians along Burke-Gilman. Both buildings hold the urban edge with a break where the courtyard reaches out to the public right of way. As can be seen in Figure 60, the ground level site plan, the courtyard is a major site element that was developed from the student housing and the school being broken in to two separate buildings. From this courtyard, a place of activity and circulation, north south foot traffic can occur making this a

View along Burke-Gilman Trail from 14th Ave NW and NW 45th St



Figure 59 - View at the intersection of NW 45th St and 14th Ave NW and along the Burke-Gilman Trail, looking west.

more human scaled sized block. The relationship of the two buildings outline the spatially defined courtyard while still allowing for fluid travel to happen, seamlessly mixing the community and the school. The ground level of the school holds classes, administrative, counseling center, the flexible Innovation space, and the lab space. The ground level of the school and the ground level of the housing massing encouraged movement and activity, making the courtyard

Site Plan



Figure 60 - Figure ground site map showing the first level of both the Job Corps Program and the housing massing.

a focal point of activity. On site bio-retention and pervious concrete pavers will allow for responsible water run off. Trees, planters and green space within the courtyard will allow for further definition of space.

Through a series of plan vignettes, some examples are shown for how the courtyard might be used. Figure 61 indicates a typical day of student activity: students walking between their dorm and the school. Large scale construction projects might spill over in to the courtyard. Students may walk south to connect to the Burke-Gilman to head into Ballard or Fremont or for exercise. Or they may walk north to the Traders Joe's for some groceries. Figure 62 shows how materials flow might function. There is a large garage door on the western wall of Lab. In off hours, typically early morning, loading trucks will enter the site from the north or south and stop alongside the Lab to unload materials such as tools, new 3-D printers, filaments or powders used to create the 3-D prints or they may pick up materials such as projects created by students that may be sold in use for manufacturing, technology, or health. Figure 63 shows the final and potentially most active courtyard life. Weekend events such as farmers markets could fill the space with tents.

Student Activity in the Courtyard



Figure 61 - Courtyard plan showing student activity. Large scale projects spreading out to courtyard and student circulation.

Materials Loading in the Courtyard



Figure 62 - During off-school hours, materials loading will happen through the western garage door into the lab.

Trade or craft fairs would be particularly relevant for the courtyard given the schools designation of specialization. Local artisans and craftsman could come together to show off, sell, and trade their goods.

On the following page, Figure 64 is a rendering of a typical day in the courtyard. This view is from the courtyard looking east towards the school. It portrays students walking either to the school or to their dorms, sitting on the benches during a break or gathering to converse. This view also shows the large vertically raising wall in the up position, allowing for activity to seamlessly flow from the Innovation space to the courtyard. The vertically spanning metal siding continues to clad the facade on this side of the building, reinforcing the industrial precedent of the site. When the door is relegated to the down position, a series of man doors still allow for easy access to the courtyard. The Innovation facade treatment utilizes the wood and polycarbonate panels that was described previously; wood panels provide indication of the structural logic, polycarbonate panels provide insulating features while still allowing light to be transmitted. The wood and poly grid system frame both entry and the king-pin truss system.

The primary pedestrian entry along NW 14th Ave, seen in Figure 65, follows a similar logic in regards to facade treatment. Vertically spanning metal siding in reference to the industrial integrity of the neighborhood, high levels of transparency at the pedestrian scale, and wood column structural system

Weekend Events in the Courtyard



Figure 63 - During the weekends, farmer's markets or crafts fairs could fill in the courtyard.

Student Activity in the Courtyard



Figure 64 - View from the courtyard looking east.

exposed to the exterior. The Innovation space is set back, allowing the Lab and admin programs to wrap the entry. This is further defined by the change in architectural language of the building - two shed style roofs being intersected by a larger cubic volume indicating a special use for this central space.

Upon entry to the school, the user finds him or herself in the large innovation space, the central feature of the building (*Figure 66*). This large room is intended Primary Entry along NW 14th Ave



Figure 65 - View from NW 14th Ave looking west to the front entrance of the Job Corps Program.

to be a flexible gallery or exhibit space. Large events could take place here for the school or to be rented and used by other groups for similar functions. This space will act as a light well, receiving direct light and indirect light from the south and north clerestories respectively and the western facing light monitors. The poly panels will further allow a diffused light to enter the space. Almost all vertical and horizontal circulation will stem from this space, making it an obvious place of intersection where students are most likely to cross paths with each other. A small cafe on the northern side of the room may also provide a location for gathering.

Ground level Program and Circulation Diagram

Figure 67 shows a section perspective of the building. Here the sense of the spatial hierarchy between the Lab, Innovation space, and student oriented program is seen. The Innovation space height allows for a sense of grandeur while equally important programmatic functions move of from either side of the space.

Once in the school, the user can easily move into the Lab space (Figure 68). This will be the primary place of learning and where a majority of the students

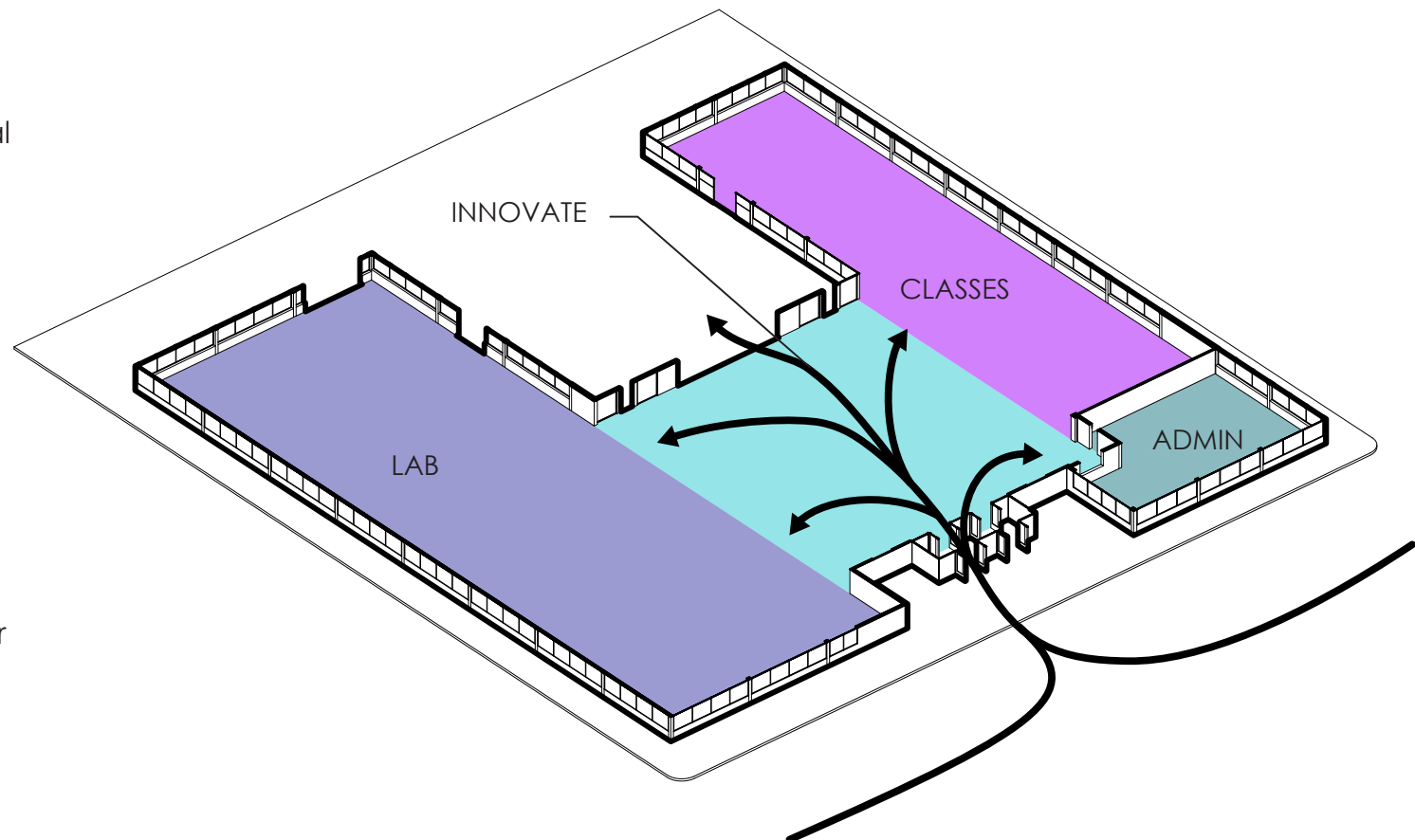

Figure 66 - Basic program and circulation diagram. Circulation will flow fluidly from the central innovation space to the courtyard, lab, student space, or administrative.

Section Perspective



Figure 67 - Section perspective cutting through the lab, Innovation space, and student space.

work will take place. In the lab space, will be a collection of 3-d printers, digital workstations where students can create digital versions of their work before sending it to the 3-D printers to be physically produced. There will be several types and sizes of 3-D printers, allowing students to be trained in all of the latest technologies and use a wide array of materials for their studies. A surprising amount of post-production work can be required, depending on the type of printer and material used, so large work surfaces will be available for students for post production when needed. There will be a viewing platform for other people to be able to watch the Lab in action. A system of louvers will be on

View of the Lab



Figure 68 - View in the Lab space looking east. This is where students will work with 3-d printers, developing modeling technique and post-production.

the southern facade to allow light to be dispersed before entering the space, avoiding glare issues with the work being completed. There are a series of small rooms along the northern wall for more intimate work environments as well as some light sensitive modeling and printing techniques.

From the lab space, students will also be spending time in the flexible classrooms. On the ground level are several smaller computer labs and informal meeting spaces. There are no desk and white board, "cells and bells" style classrooms in the facility. The administration and counselor's office will be on the ground level at the north east corner where they can have eyes on the front door to have some sense of who is entering the school. Once upstairs, there is more student oriented program - flexible walls with desks on rollers to allow for rooms of different sizes and capabilities. The leasable Makerspaces will also be on the second floor, encouraging the professionals who rent the space to circulate throughout the building. Students will also be able to use the makerspace as workspace for themselves. The walkway the surrounds the innovation space is generous which allows for both circulation and impromptu conversation to occur. The program continues in similar fashion on the third level (*Figures 69 and 70 for Level 2 and Level 3 plans*).

Level 2 Plan of Job Corps

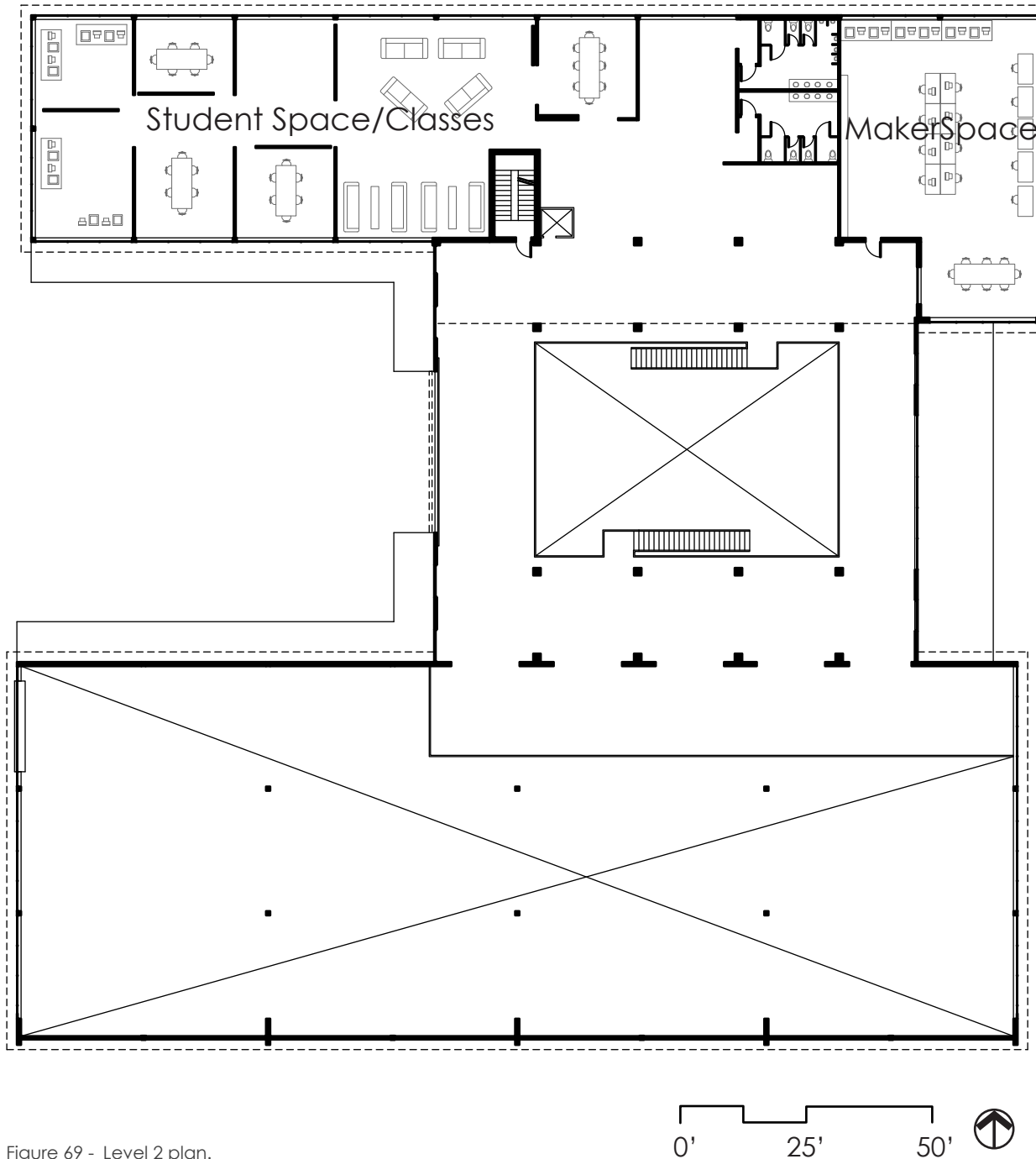

Figure 69 - Level 2 plan.

Level 3 Plan of Job Corps

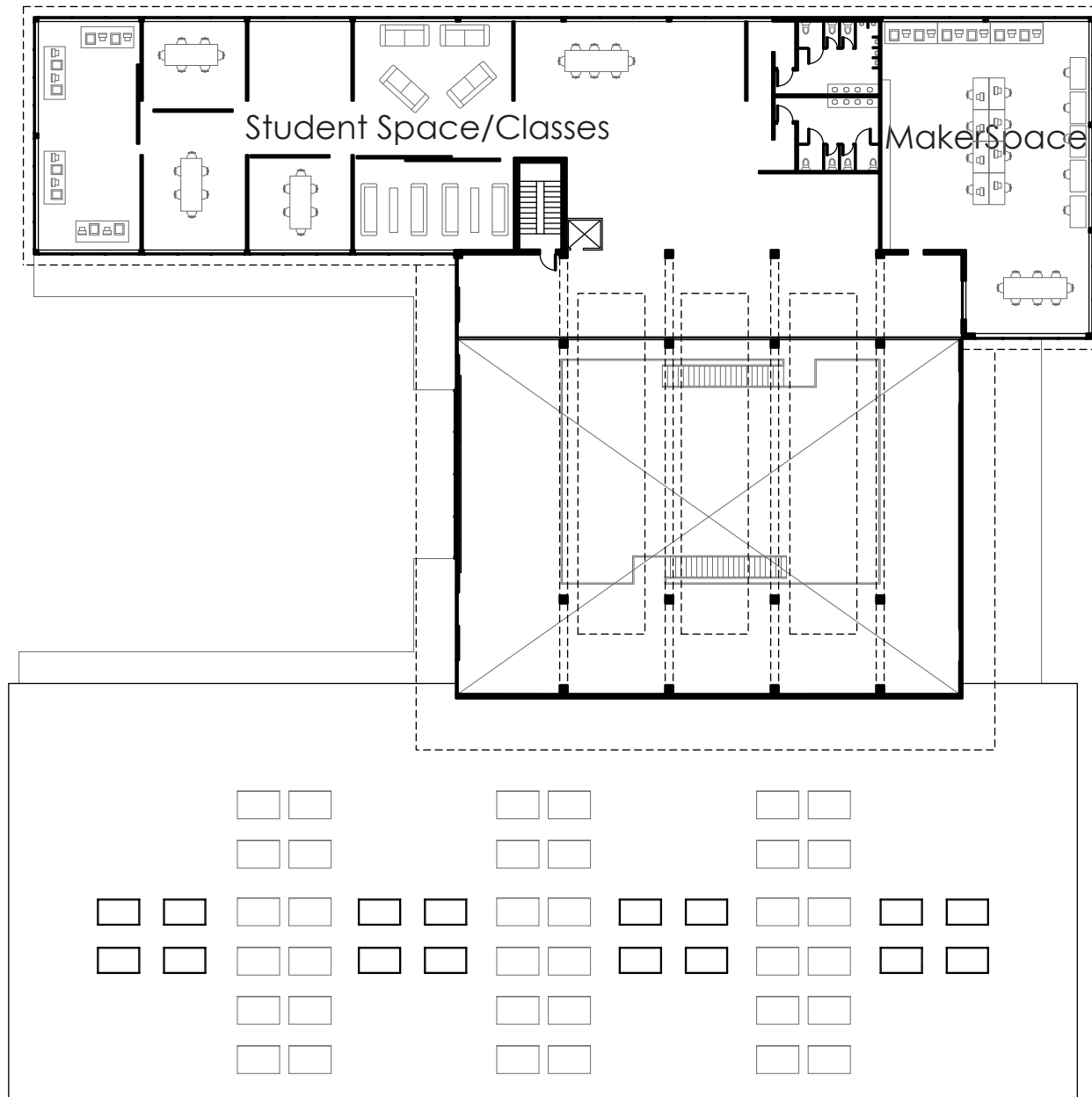
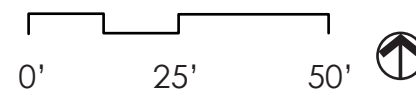

Figure 70 - Level 3 plan.



7. Conclusion

Through a rigorous analysis of career and technical educational facilities, a modern version of a trade school is provided for the Seattle region. A program that benefits all parties involved: Job Corps, the local population, and a fruitful educational option that will streamline training options for skilled labor available to the younger demographic of Seattle while offering the possibility of professionals to continue their own educational options.

This school will train young adults, many from struggling backgrounds, into a level of skilled technician that is applicable to several of the largest employment industries in the Seattle region. Through careful design and program allocation, this Job Corps program will provide a new model for other urban Job Corps programs to follow. A condensed campus style with housing allows for the program to bring in some income while letting the students learn a level of independence. From what the users learn during their time in this school, they will be able to earn a livable wage, providing dignity, autonomy, and self-reliance to a capable group of young adults. In this specialized Job Corps Magnet Program a piece of architecture allows the opportunity for the students to learn to work.

View of the Innovation Space



Figure 71 - View from the level 2 walkway into the central innovation space.

This page is blank.

BIBLIOGRAPHY

"Mapping Historic Ballard Overview – Ballard Historical Society." *Ballard Historical Society*. Web. 14 June 2017.

Bonwell, C., and J. Eison. *Active Learning: Creating Excitement in the Classroom*. Rep. Vol. 1. Washington, DC.: George Washington U, School of Education and Human Development, 1991. Print. ASHE-ERIC Higher Education Report.

Billet, Stephen. Stevenson, John C., et al. *Developing Vocational Expertise: Principles and Issues in Vocational Education*. Crows Nest, N.S.W. : Allen & Unwin, 2003.: Allen & Unwin, 2003. Print.

Burghardt, John, Peter Z. Schochet, Sheena McConnell, Terry Johnson, R. Mark Gritz, Steven Glazerman, John Homrighausen, and Russell Jackson. *Does Job Corps Work? Summary of the National Job Corps Study*. Rep. Princeton, NJ: Mathematica Policy Research, 2001. Mathematica Policy Research. Web. 25 May 2017.

Epperson, Lia. *Bringing the Market to Students: School Choice and Vocational Education in the Twenty First Century*. Symposium: Educational Innovation and the Law. Proc. of Educational Innovation and the Law.: Notre Dame, IN: Notre Dame Law School, 2012. Print. 87 Notre Dame L. Rev. 1861.

"Explore Fleming." Fleming College. 12 May 2017. Web. 14 June 2017. <https://flemingcollege.ca/news/fleming-college-school-of-trades-and-technology-hosting-skills-camps/>

Glatter, Hayley, Emily DeRuy, and And Alia Wong. "Re-imagining the Modern Classroom." *The Atlantic*. Atlantic Media Company, 02 Sept. 2016. Web. 17 June 2017.

Graetz, Ken. Oblinger, Linda, ed. *Learning Spaces*. Chap. 6 "The Psychology of Learning Environments" by Ken Graetz. Boulder, CO: Educause, 2006. E-book. 10 June 2017 <<http://net.educause.edu/ir/library/pdf/PUB7102.pdf>>

Hanford, Emily. "The Troubled History of Vocational Education." American RadioWorks. 9 Sept. 2014. Web. 16 June 2017.

Imperatore, Catherine. "A Brief History of CTE." Web. 15 June 2017. <<http://www.minnstate.edu/system/cte/documents/cte-history-timeline-2017.pdf>>

Kavilanz, Parija. "Trade-school Grads in Hot Demand for Manufacturing Jobs." CNNMoney. Cable News Network, 23 July 2012. Web. 29 Mar. 2017.

Kaplan, Stephan and Kaplan, Rachel. *Cognition and Environment: Function in an Uncertain World*. Ann Arbor, MI: Ulrich's, 1983. Print.

Seftel-Kirk, Heather. "Amalgamation Creates New-style \$40M Secondary School with Community Consultation and Thoughtful Co-ordination." Northern Ontario Construction News (2011): B1. Superior Heights Collegiate & Vocational School. The Ontario Construction Report, Aug. 2011. Web. 14 June 2017.

BIBLIOGRAPHY (continued)

Pesquera, Adolfo. "The End of Cells & Bells: School Design in the 21st Century." Virtual Builders Exchange. 31 July 2015. Web. 10 May 2017.

PY 08: U.S. Department of Labor Job Corps Annual Report: Washington, DC: U.S. Department of Labor. 2009, Web. <<http://www.jobcorps.gov/Libraries/pdf/py08report.sflb>>

Schochet, Peter Z., John Burghardt, and Sheena McConnell. *Does Job Corps Work? Impact Findings from the National Job Corps Study*. American Economic Review 98.5 (2008): 1864-886. JSTOR. Web. 25 May 2017.

"Seattle's Key Industries" *Office of Economic Development*. seattle.gov. 2017. Web. 5 May 2017.

Smith, Rob. "Seattle-area Business Leaders Cite Skills Shortage as Biggest Barrier." Bizjournals.com. Puget Sound Business Journal, 29 June 2016. Web. 12 April 2017.

Wurdinger, Scott D., and Julie Carlson. *Teaching for Experiential Learning: Five Approaches That Work*. New Delhi: Overleaf, 2011. Print.

Appendix

This series of maps shows employment by home address, indicating dramatic change over the years. While manufacturing has dropped, most notably between 2010 and 2015 the health and tech industries have grown rapidly. These three fields make up some of the larger proportions of work for the Seattle area. All data from simplyanalytics.com, a data aggregating map making tool. They sourced their information from US Census data. The maps are seperated by census tracts.

Manufacturing

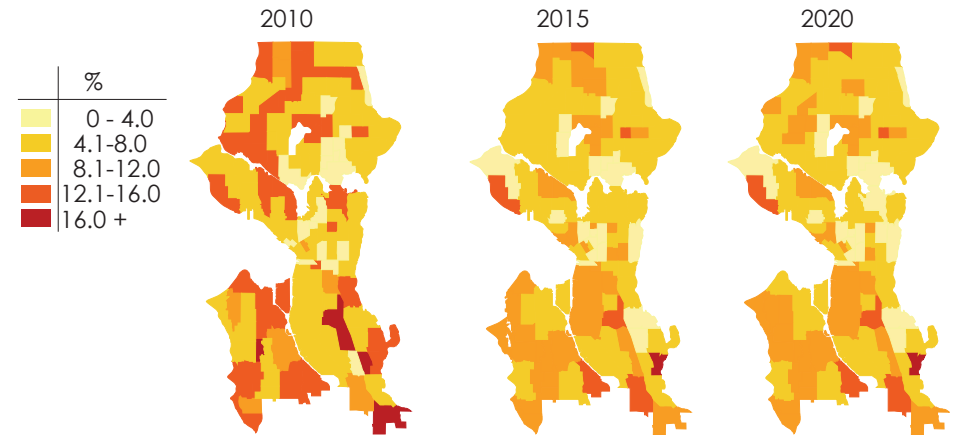

Health

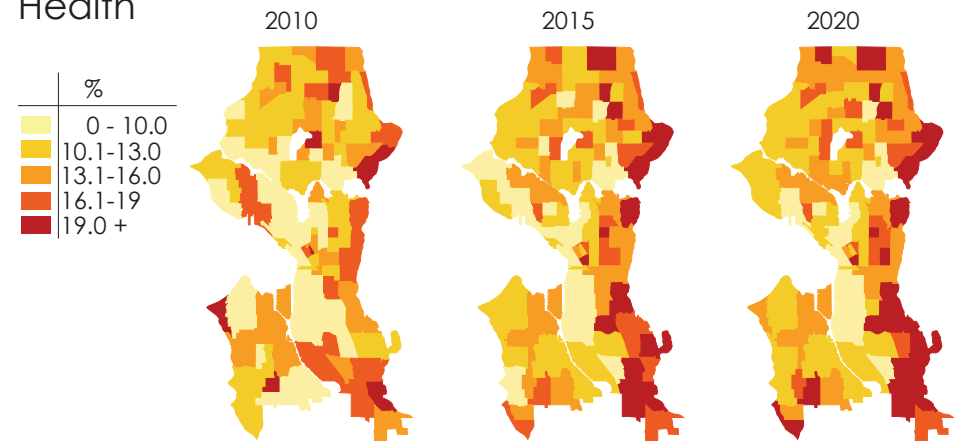

Tech

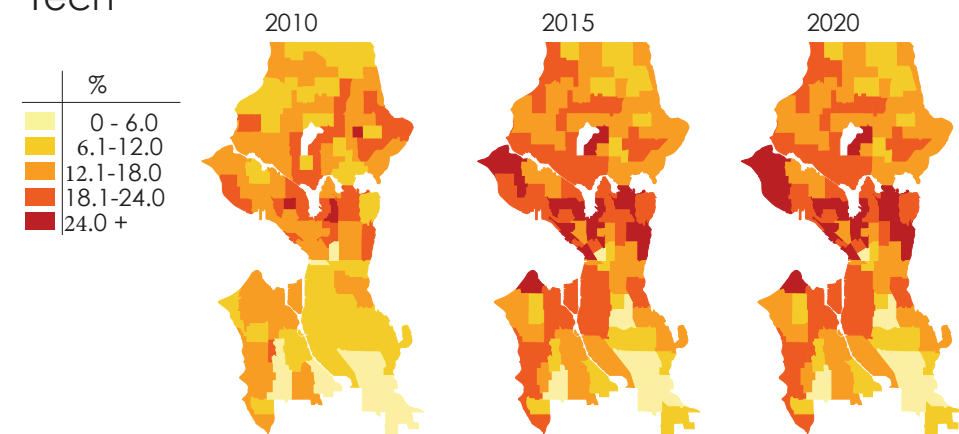

Appendix (continued)

This diagram was used in the thesis presentation as a graphical representation for how the use of 3-D printers can be applied to the different industries.

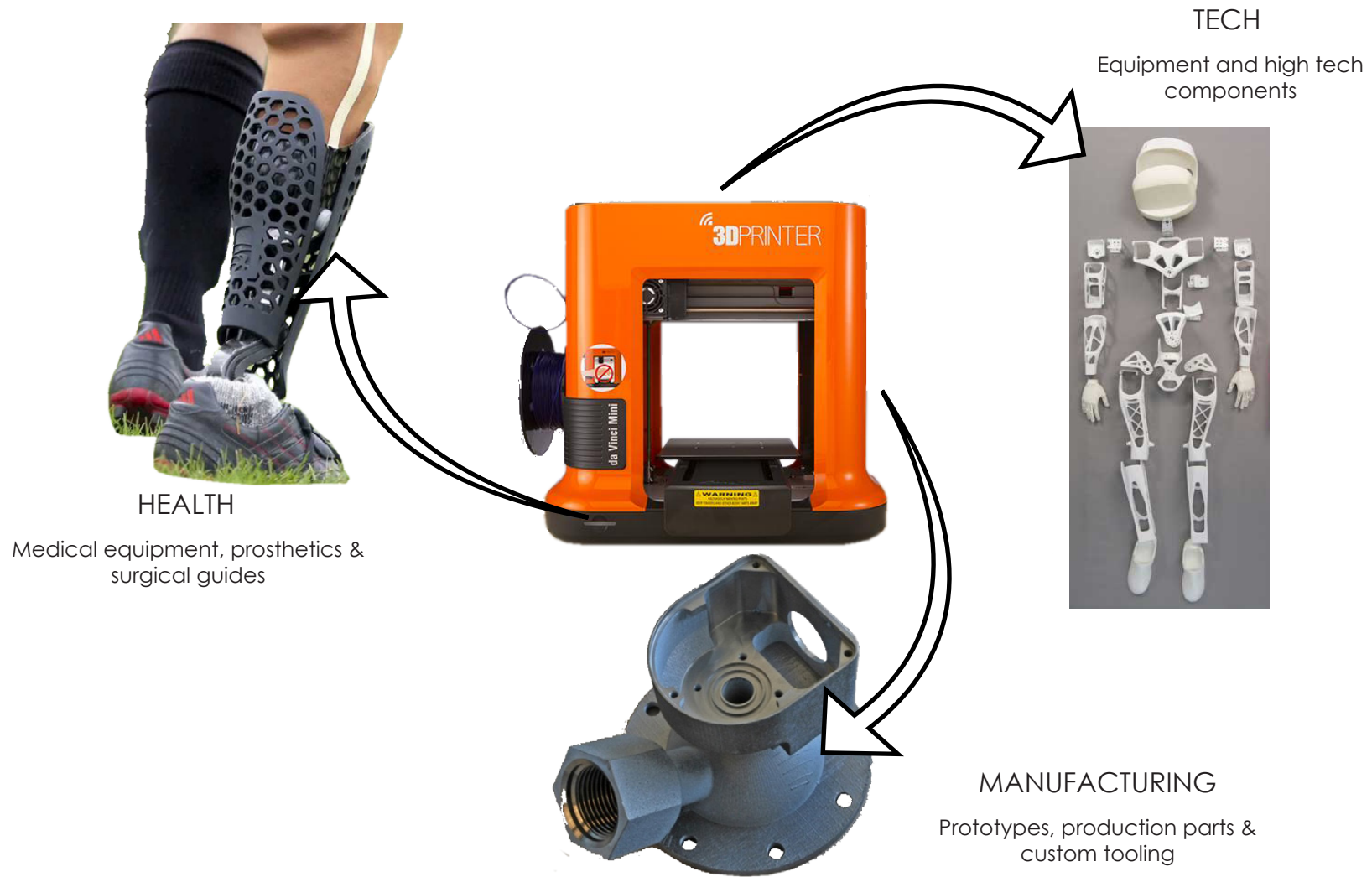

Appendix (continued)

These bar graphs graphically indicate the types of duration of programs that would be offered at the school.

EX. 1: Non-High School Graduate/
Non-GED Holder

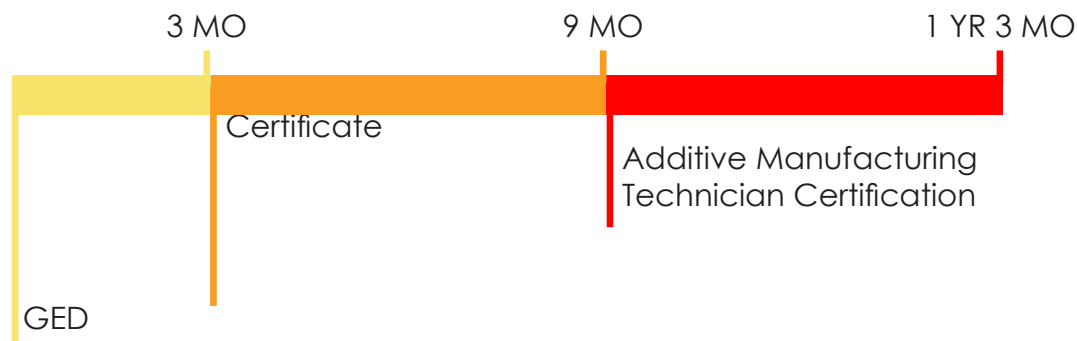

EX. 2: High School Graduate/
GED Holder

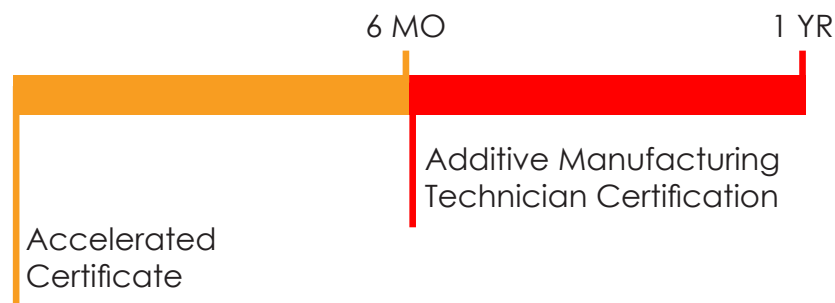

EX. 3: Professional

