

low-tech.high-touch:
DNA-BRICK ASSEMBLY

Yasaman Haji Esmaili

A thesis
submitted in partial fulfillment of the
requirements for the degree of

Master of Science in Architecture

University of Washington
2015

Committee:
Rob Corser
Elizabeth Golden
Brian Johnson

Program Authorized to Offer Degree:
Design Computing

© Copyright 2015
Yasaman Esmaili

ACKNOWLEDGMENT

I would like to thank my committee members for their guidance, patience and encouragement.

Thank you Rob for helping me understand how material properties and craftsmanship can shape the computational design processes and for helping me explore new possibilities.

Elizabeth, thank you for trusting me to be part of a process which initiated my interest in learning about bricks, and for helping me find the right goals and to stay focused on them.

Brian, thank you for introducing me to a field I knew little about and for guiding me to find the right resources and to think clearly and methodically.

I would also like to thank other faculty members of the DMG, Kimo Greggs for helping me understand digital fabrication and guiding me in the process of building a brick prototype for this thesis, and Mehlika Inanici for her suggestions on how to incorporate natural light in this work.

Thanks to Mutual Materials for their generous brick donation. Penny and Steve, thanks for guiding me on using the fabrication lab. Thank you Dechen, Mariam, Maya, and Will for joining me to experiment with bricks.

I would like to dedicate this work to my parents and my sister for their unconditional support and love.

University of Washington

Abstract

Low-tech. High-touch: DNA Brick Assembly
Yasaman Esmaili

Chair of Supervisory Committee:
Rob Corser

Department of Architecture

ABSTRACT

Brick is a low-cost, low-tech building material and is abundant in highly-populated areas of the world. The simple, symmetric form of bricks allows for complex unit-to-unit connections that can create a variety of different forms, patterns, and openings in a brick wall. Building unique forms and patterns with bricks, however, relies upon highly-skilled masons and the design process can be challenging for the architect.

This thesis proposes the use of algorithmic computational 3d modeling software and low-tech brick masonry techniques to create a tool that allows the users to design brick masonry walls in a digital world. This process lets the designer simultaneously study different design factors including form, pattern, and solar exposure and also allows the designer to communicate the result with the mason using simple paper guides called “DNA guide”. The DNA guide instructs the mason on the assembly of the complex brick systems. Rather than solely relying on high-tech tools, this approach builds upon existing low-tech methods for greater global implementation at smaller costs. The design tool connects high-tech computational methods with traditional brick masonry practices to create a “high-touch”, more responsive process.

As part of this thesis, a full scale prototype was designed and constructed. The sculptural brick screen acts as a transitional element for a building and responds to environmental and seasonal changes by controlling light, air and views.

TABLE OF CONTENTS:

LIST OF FIGURES	6
INTRODUCTION	8
PART ONE: Low-tech. High-touch	12
PART TWO: Earthen Architecture	14
PART THREE: Earthen Masonry Blocks	16
3.1. Brick and Mortar.....	17
3.2. Brick bonding.....	18
3.3. Patterns, Forms and openings.....	20
PART FOUR: Screen, a Transitional Element	23
PART FIVE: A Parametric Design Approach:	25
5.1. Wall Form.....	25
5.2. Pattern.....	26
5.3. Color.....	26
5.4. The sun.....	26
5.5. Construction process.....	28
PART 6: The Process: DNA-Brick Assembly	32
6.1: DNA-Brick Assembly: the design process.....	37
6.1.1. Step one: build the wall.....	38
6.1.2. Step two: Pick a color.....	45
6.1.3. Step three: Size the screen.....	46
6.1.4. Step four: Study the sun.....	47
6.1.5. Step five: Pattern.....	50
6.2: DNA-Brick Assembly: the construction process.....	63
6.2.1: DNA guides.....	76
6.2.2: Smart guides.....	70
6.2.3: Construction kit.....	71
6.2.4: Construction sketches.....	72
PART 7: Prototype	79
SUMMARY AND FUTURE WORK	96
BIBLIOGRAPHY	98

LIST OF FIGURES

Figure 1: Siosepol, Iran1599

Figure 2: Parametric relation between design factors

Figure 3: From low-tech to (high) low-tech

Figure 4: Exploring means for transferring the data/design

Figure 5: Dried clay

Figure 6: World Population

Figure 7: Dominance of earthen architecture in the world

Figure 8: Bricks including fired bricks, mud bricks and CEBs

Figure 9: Cored and solid bricks

Figure 10: Brick and mortar

Figure 11: Brick joints

Figure 12: Three bricks in a row

Figure 13: Shifting the top course

Figure 14: Various brick bond patterns

Figure 15: Creating curved forms

Figure 16: Self-lateral resistance

Figure 17: Creating openings

Figure 18: Historic and contemporary examples of brick structures

Figure 19: Single-wythe brick wall

Figure 20: Multiple-wythe brick wall

Figure 21: Cellular structure of bone

Figure 22: Creating a screen from a flat brick wall

Figure 23: Creating a screen from a curved brick wall

Figure 24: 3D modeling brick walls with different forms

Figure 25: Add color/Material to the wall

Figure 26: Add patterns to the wall

Figure 27: Study the sun

Figure 28: Robot Mason

Figure 29: 3D printed bricks

Figure 30: Global access to robot mason or 3D printing versus the prominence of earthen architecture in the world

Figure 31: Robot mason versus human mason

- Figure 32: Guiding the masons
- Figure 33: Low-tech/high-touch
- Figure 34: DNA Brick assembly
- Figure 35: Rhino/Grasshopper/Ladybug
- Figure 36: Typical Grasshopper work-flow
- Figure 37: DNA assembly grasshopper work-flow
- Figure 38: form/visualization/sun/pattern
- Figure 39: Flemish bonding
- Figure 40: creating the base wall
- Figure 41: curving or tilting the wall
- Figure 42: measuring minimum overlap between bricks
- Figure 43: testing the surface
- Figure 44: adjusting the surface to create the wall
- Figure 45: High-density housing project in Niamey, Niger
- Figure 46: South-facing screens
- Figure 47: Create the flat wall
- Figure 48: Pick a color for bricks
- Figure 49: Size the screen
- Figure 50: Pick the location and time of the year
- Figure 51: Study the sun
- Figure 52: Suggestions for south-facing wall
- Figure 53: Suggestions for east/west facing wall
- Figure 54: Brick options
- Figure 55: Brick opening options
- Figure 56: Number of options for creating patterns
- Figure 57: Vertical reinforcement
- Figure 58: Horizontal reinforcement
- Figure 59: Suggested reinforcement grid, 10 courses and 7 columns of brick
- Figure 60: Reinforcement grid options
- Figure 61-63: Brick swatch pattern
- Figure 64: Designing the bottom portion of the screen
- Figure 65: The pattern swatch
- Figure 66: The bottom portion of the screen

Figure 67: The top and bottom portion of the screen
Figure 68: Fully designed screens
Figure 69: Guiding the mason
Figure 70: The Brick Pattern House
Figure 71: Brick construction sketches by Lauri Baker
Figure 72 and 73: Designing and customizing a brick screen
Figure 74: DNA Brick guide
Figure 75: The base level of the DNA brick guide, physically printed
Figure 76: Level 1 of the DNA brick guide
Figure 77: Smart metal/plastic/fabric guide
Figure 78: High-tech DNA guide
Figure 79: Mason tools and Low-tech building material
Figure 80: Construction sketch 1: roll the paper guide out
Figure 81: Construction sketch 2: draw the base curve on the ground
Figure 82: Construction sketch 3: add reinforcement bars
Figure 83: Construction sketch 4: add the string guide
Figure 84: Construction sketch 5: build the wall based on the guides
Figure 85: Construction sketch 6: bend the r-bars to match the curvature
Figure 86: Construction sketch 7: Add horizontal the reinforcement
Figure 87: Construction sketch 8: tie the vertical reinforcement bars together
Figure 88: Finishing the wall
Figure 89: The complete wall
Figure 90: Brick screen prototype
Figure 91: Brick screen prototype renderings
Figure 92: The base of the wall
Figure 93 to 102: Building process
Figure 103: Brick prototype DNA guide
Figure 104: Brick prototype DNA guide, level 1
Figure 105: Building according to the wall
Figure 106 to 117: Building process
Figure 118 to 126: The built prototype

INTRODUCTION

Architecture can be called journalism in stone, since it should reflect the culture, climate, and resources of the time and place¹. Today more than 70 percent of the architectural projects are designed by foreign architects². This phenomena raises a question that how one should mediate the impact of global civilization considering elements derived from distinctive characters of a place. Even when the architects are not foreign, they are not inherently aware of all the peculiarities and problems of a particular place or project , unless they achieve a high level of critical self-consciousness³.

The main challenge for many architectural projects in less privileged locations of the world is their lack of access to adequate outside energy sources and high-tech material. In order to put advanced design ideas into practice, making location-specific decisions is necessary. Therefore, the design decisions should not merely depend on high-technology. Through appropriate application of computational technology, digital tools can help in revitalizing and improving low-tech building solutions.

In order to create cost-effective, performative prototypes that are derived from the local culture and also benefit from the advancement of universal technology, architects should identify patterns that reflect various factors in an integrated way. This network of factors can include using low-cost local material, achieving energy efficiency, considering cultural influence and aspects like human labor, economy, and design and construction automation.

1 Lechner, Norbert, *Heating, Cooling, Lighting: Sustainable Design Methods for Architects*, (Wiley 2014), p8.

2 TED talk by Alastair Parvin, accessed Sep 25, 2014, http://www.ted.com/talks/alastair_parvin_architecture_for_the_people_by_the_people?language=en.

3 Fampton, Kenneth, *Modern Architecture: A Critical History*, (Thames & Hudson 2007), p3.

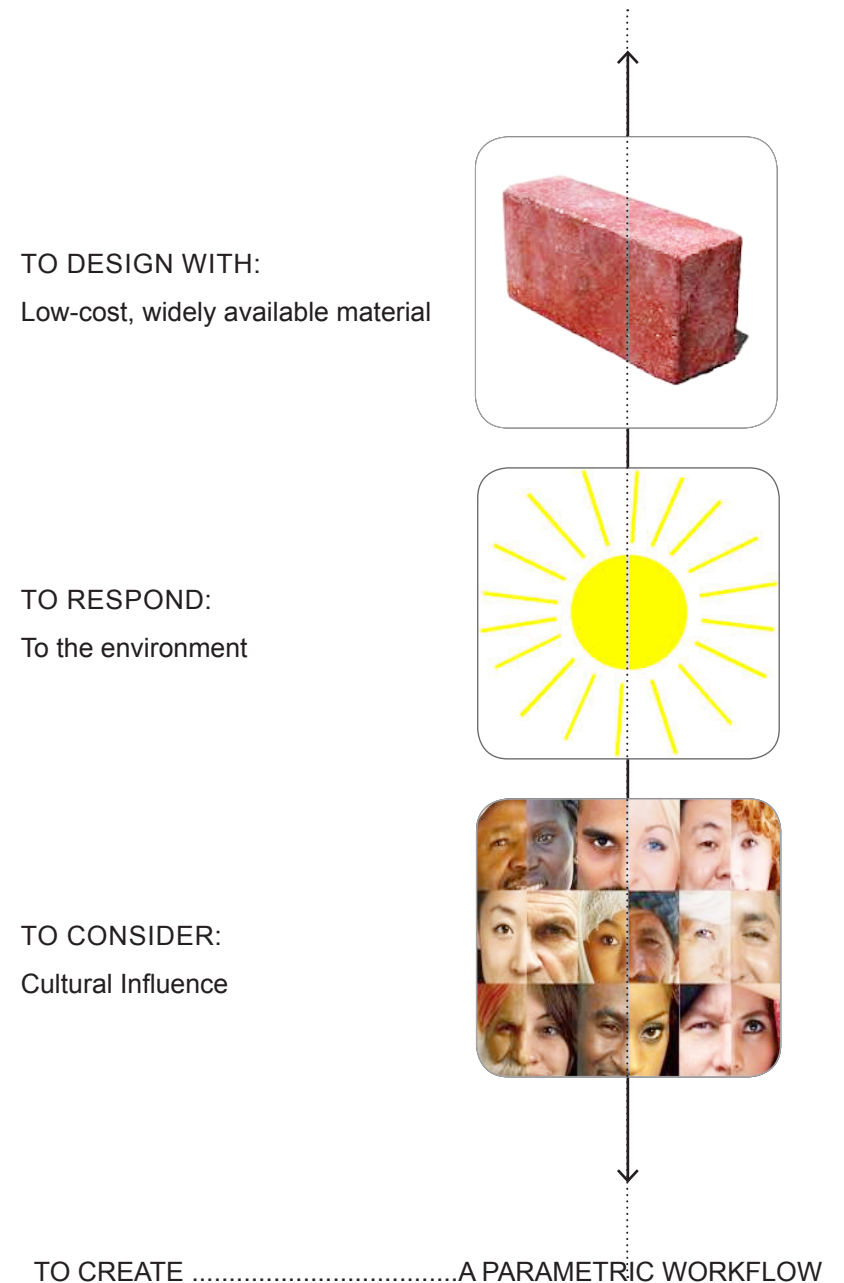

Figure 1: Siosepol, Iran 1599 @www.isfp.ir

The task here is to identify the pattern of the problem and the process of designing a prototype which responds to that problem. Achieving such a logical structure to represent design problems brings with it the loss of innocence in design because a rational process is easier to understand and criticize compared with a fuzzy design approach⁴. This logical process can be achieved by introducing mathematics to the design process as a tool that helps in studying and controlling a network of factors.

Using mathematical logic available through computational tools can let the designer consider various aspects simultaneously and study their inter-relation and interaction to find better solutions. In the natural world, the characteristics of even the most complex forms can be understood using mathematical methods⁵. In the same method, algorithms can help the designer consider factors like material properties, passive-design strategies and cultural influences. By parametrically relating these factors during the design process, each can be adjusted and improved, leading to better overall options (Figure 2).

To test and present this integrated approach, this thesis looks at brick, as a generally low-tech and low-cost material that is available in many regions of the world and is widely used in building construction. The thesis outlines a parametric design methodology for a responsive brick screen system using Rhino/Grasshopper interface.



4 Alexander, Christopher, *The timeless way of building*, (Oxford University Press, 1979), p8.

5 Thompson, Darcy, *On Growth and Form*, (Cambridge University Press, 1992), p269.

Figure 2: Parametric relation between design factors

In masonry construction, both structural and formal compositions depend on consistency and symmetry. Brick is both symmetrical and reproducible and therefore easily meets the needs of the assembly. In its simplicity, however, this elementary unit simultaneously allows for variation of form through an increased complexity of unit-to-unit connections⁶. This variation in connecting bricks can create many design options, each responding differently to their environment both in terms of aesthetic and performance.

The screen systems targets locally available material systems and low-budget for construction. The focus is on making the process easy to use by designer and understandable and easy to apply by masons. By letting the architect have control over placement of each brick within a brick masonry wall, it is possible for the designer to become a mason in the digital world and quickly study design options that could be applied to the real world, based on the properties of the masonry blocks.

6 Petrovic, Pavel, "Solving LEGO brick layout problem using Evolutionary Algorithms", Proceedings to Norwegian Conference on Computer Science, 2001.

PART ONE: LOW TECH. HIGH TOUCH

*“When does high-tech becomes low-tech and more dramatically when does high-tech becomes high-touch? high-tech becomes high touch with longevity and cultural familiarity old-fashioned technologies become reference points to us all.....they evoke emotions. High-tech has no reference point yet.”*⁷

Low-tech building solutions have been gradually developed over thousands of years according to the actual needs of a community and capable of responding to location-specific requirements. High-tech computational design has transformed the precision and control the designers can have over exploiting materials and studying design options. But where can the two meet? How can innovation in construction reflect the lessons that are learned from vernacular and low-tech building solutions? How can technology let us create new low-tech solutions that are as context-aware as low-tech solutions and also reflect technology?

To achieve such goal it is one should apply the precision and design innovation that computational technology offers to traditional building systems during the design and construction process, in a context-aware manner (figure 3). This approach should build upon the techniques that have been used and tested for thousands of years and transform them to meet the criteria and limitations of modern construction. High-tech becomes high-touch if it can bridge tradition and innovation and also improve low-tech to be more responsive to the complexities of the modern society.



reference low-tech

high-touch

context-aware

new (high)- low-tech

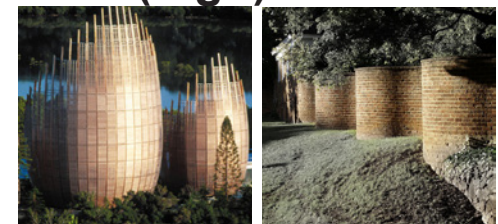

Renzo Piano's Gorgeous Jean-Marie Tjibaou Cultural Center @ <http://inhabitat.com/>

uva serpentine wall @ <http://commons.wikimedia.org/>

Figure 3: From low-tech to (high) low-tech

⁷ John Naisbitt, *high-tech.high-touch*, (Broadway Books 1999), p27

High-touch design approach should be based on clear communication between all the parties that influence the design and construction process. This includes the architect, the client and the builder. In the design process of vernacular low-tech buildings often the designer, the builder, and the client would be the same person or group of people. This would let them have an integrated approach to design and be aware of the main objectives that would lead to a better overall design solution. It would also allow for better craftsmanship because the builder could be the designer and also the designer could practically build and test his ideas.

The complexities of the contemporary societies doesn't allow for the same design/building process because the number of factors that should be considered during the design and construction process can't be easily understood and controlled by one party. Also often the architect, the builder and the client are not in the same location and therefore there is a clear gap of communication between them specially when the architect design projects oversees.

This gap of communication can be filled by using computational tools for transferring data and design ideas and by creating a communication language that is clear for the architect, the builder, and the client. By using the mathematical logic that is offered by computational technology it will be possible to keep track of many different design factors during the design and construction process and keep the architect , the community and the builder involved in all stages of the process (figure 4).

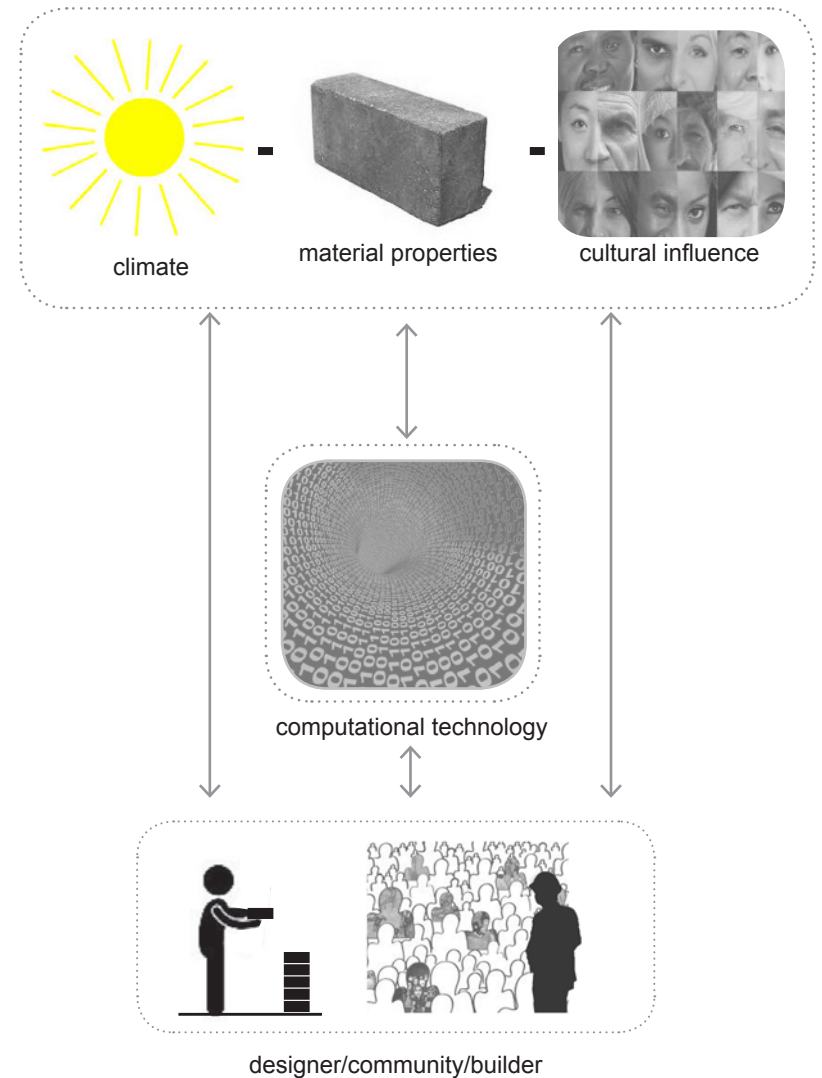

Figure 4: Using computational technology for transferring the data and keeping track of design factors

PART TWO: EARTHEN ARCHITECTURE

Earth, as the substance that covers our planet, is everywhere around us. It is found in various forms and densities, shaping the natural landscape. A mixture of water and earth creates a soft, sticky material called mud. Mud is one of first materials that was used to create structures. It is widely available and cheaper than most of the other building materials. It has been used in various forms to create very low-cost, low-tech construction techniques shaping the built environment. These techniques create a particular type of architecture which is called *earthen architecture* and represent the characteristics of place and time throughout history.

Around 3100 BC the dried mud around the Tigris would crack and naturally create mud blocks. These mud blocks were used to create structures in Mesopotamia. Today, 85% of the world population lives in the driest half of the planet⁸. In such areas, earthen architecture is the most viable option for buildings and provides an affordable local building system (Figures 6 and 7). In Fact it is estimated that one half of the world's population live or work in buildings constructed of earth⁹. In India there are about 80 millions of dwellings made of earth and in China about 100 million people live in earthen homes¹⁰. Earthen buildings are used as almost any architecture types in every economy and for various social classes.

8 United Nations Water, accessed Sep 15, <http://www.unwater.org/water-cooperation-2013/water-cooperation/facts-and-figures/en/>

9 Earthen architecture, accessed May 15, <http://eartharchitecture.org/>

10 Ronald Rael, *Earth Architecture*,(Princeton Architectural Press 2010), p9



Figure 5: Dried clay @cgtexture.com

dominant in most populated areas of the world

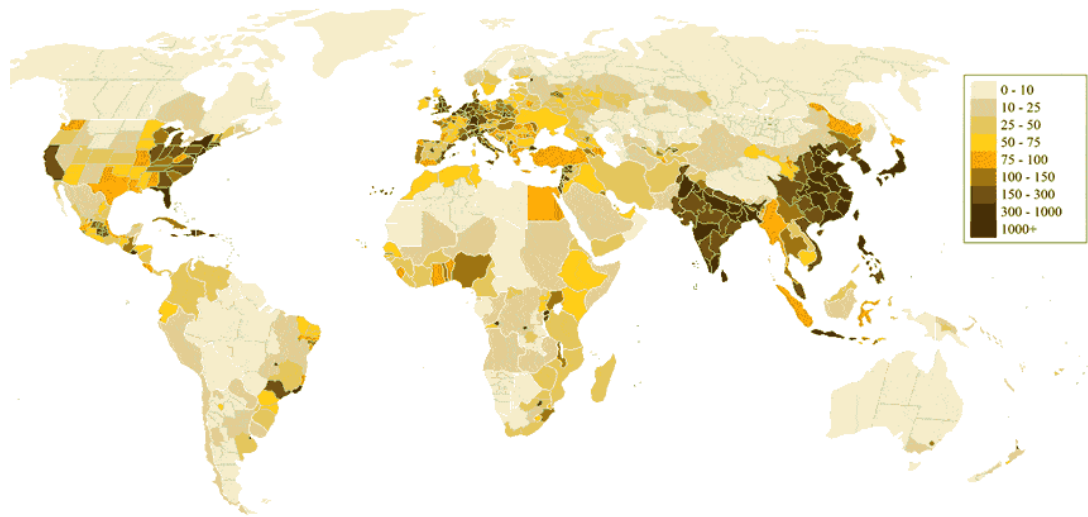

Figure 6: World Population@ <http://www.worldometers.info/world-population/>



Figure 7: Dominance of earthen architecture in the world@ <http://zemnostroitelstvo.net/>

The properties of earth in each particular location has formed diverse construction techniques of earthen architecture. The majority of these techniques can be classified in two main categories of *fired* and *unfired* Earthen construction. The unfired earthen construction techniques are classified based on the process of shaping and compressing mud in four categories of *Rammed Earth*, *Mud Brick*, *Compressed Earth Block (CEB)* and *Molded Earth*¹¹. The fired earth is shaped in forms of blocks, called Bricks, which are used in masonry construction.

Bricks act as building units. Usually these units are shaped as rectangular blocks and come in various sizes and forms. CEB units and Mud Bricks are also mostly made as rectangular blocks.

The process of forming earth as fired or air-dried blocks and attaching the Fired Bricks, Mud Bricks or CEBs in a masonry system is not only based on material and structural properties of the units and the available construction techniques. It is also influenced by the culture and represented through unique patterns particular to each location and time.

¹¹ Ronald Rael, *Earth Architecture*, (Princeton Architectural Press 2010), p10

PART THREE: EARTHEN MASONRY BLOCKS

Mud Bricks, Fired Bricks and CEBs are made in various colors and sizes depending on the properties of clay and based on common construction practices particular to each geographic location (figure 8). The term *brick*, usually refers to all these three categories.

Bricks are usually produced locally. Brick-making plays an important role in the economy of many developing parts of the world specially in locations with limited access to other building materials, like concrete and steel. The cost, availability and wide use of bricks demonstrate their importance in the built environment. Therefore studying the properties of existing brick construction systems and understanding their potential is necessary and improving their performance can lead to critical improvements in the built environment.

Brick construction is relatively inexpensive and durable and requires little maintenance. It can tolerate extreme weather and provides great resistance against fire. Brick has a high thermal capacity which makes it great to act as thermal mass. Moisture and frost can damage brick particularly in colder climates. Also air pollution and plants such as moss can adversely affect bricks.



Figure 8: Bricks including fired bricks, mud bricks and CEBs

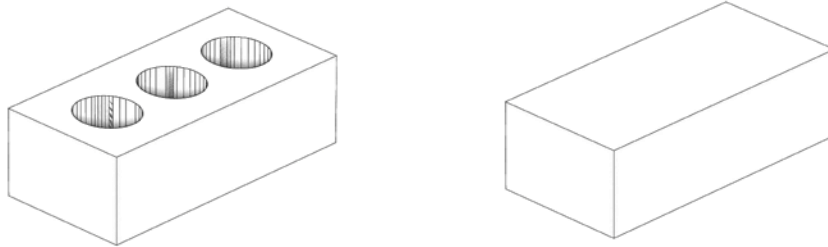

Figure 9: Cored and solid bricks



Figure 10: Brick and mortar

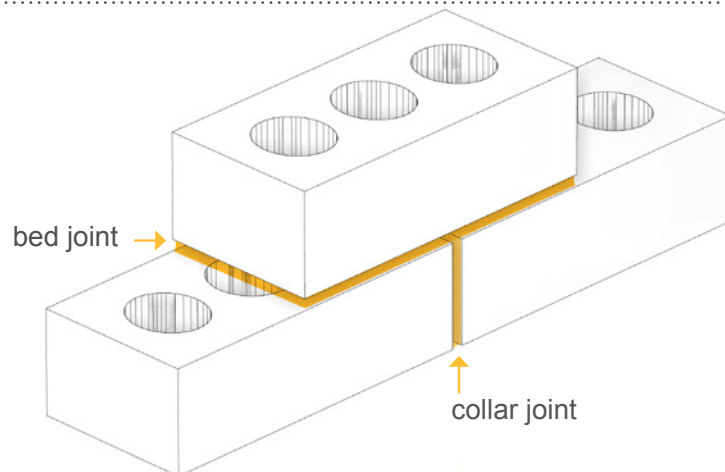

Figure 11: Brick joints

3.1. BRICK AND MORTAR

Bricks can be solid or cored. Cored bricks have holes of different types and sizes (figure 9). Holes make the bricks lighter and also saves material, resulting in cheaper masonry blocks. They also help in creating a stronger bonds, letting the mortar sink into the brick. The holes can also be used for tying bricks together by putting reinforcing elements in the holes.

Whether solid or cored, bricks are bound together with mortar (figure 10). There are different types of mortar available in each geographical location. Historically mortar was made of clay and water. In contemporary masonry construction mortar is usually a mixture of cement, sand and water (cement mortar) or lime, sand and water (lime mortar). The vertical mortar joint that bonds the bricks in a row is called *collar joint*. *Bed joint* is the term used for horizontal bonding between courses of bricks (figure 11).

3.2. BRICK BONDING

Bricks can be arranged in various bonding patterns based on structural requirements and aesthetic preferences. The ordered arrangement of parts into a pattern creates different visual effects from various distances¹². As shown in figure 12, there are four different options for just putting three bricks next to each other in a row. The full length brick is called the *stretcher* if placed with its length parallel to the wall. The same brick is called *header* if placed perpendicular to the wall. The header can be pushed inwards or outwards or can be cut in half to create a *half bat*.

In order to create structural bonding, the bricks should overlap and the top course of brick should be shifted on the bottom course. By having the collar joints shifted in each course and keeping the bed joints continuous, the mortar joints and the bricks create an interlocking grid (figure 13). The top course can be shifted on the bottom course with different proportions and styles. Each style creates a new type of brick bonding. Also depending on the way the bricks are put next to each other in a row, new types of bonding patterns are made. Some of the most common structural brick bondings are *Running bond*, *Common bond*, *Flemish bond* and *Sussex bond* (figure 14). Extending the bricks in both ways adds to the number of options for brick bond patterns.

The unit to unit connection in a brick wall allows for creation of flexible wall forms. The bricks can be slightly turned next to each other in a row to create curved brick walls (figure 15). Curvature can improve structural performance of the wall by adding to its lateral resistance (figure 16).

¹² Foerster, Bernd, *Pattern and Texture*, (Allied Masonry Council 1961), p.7.

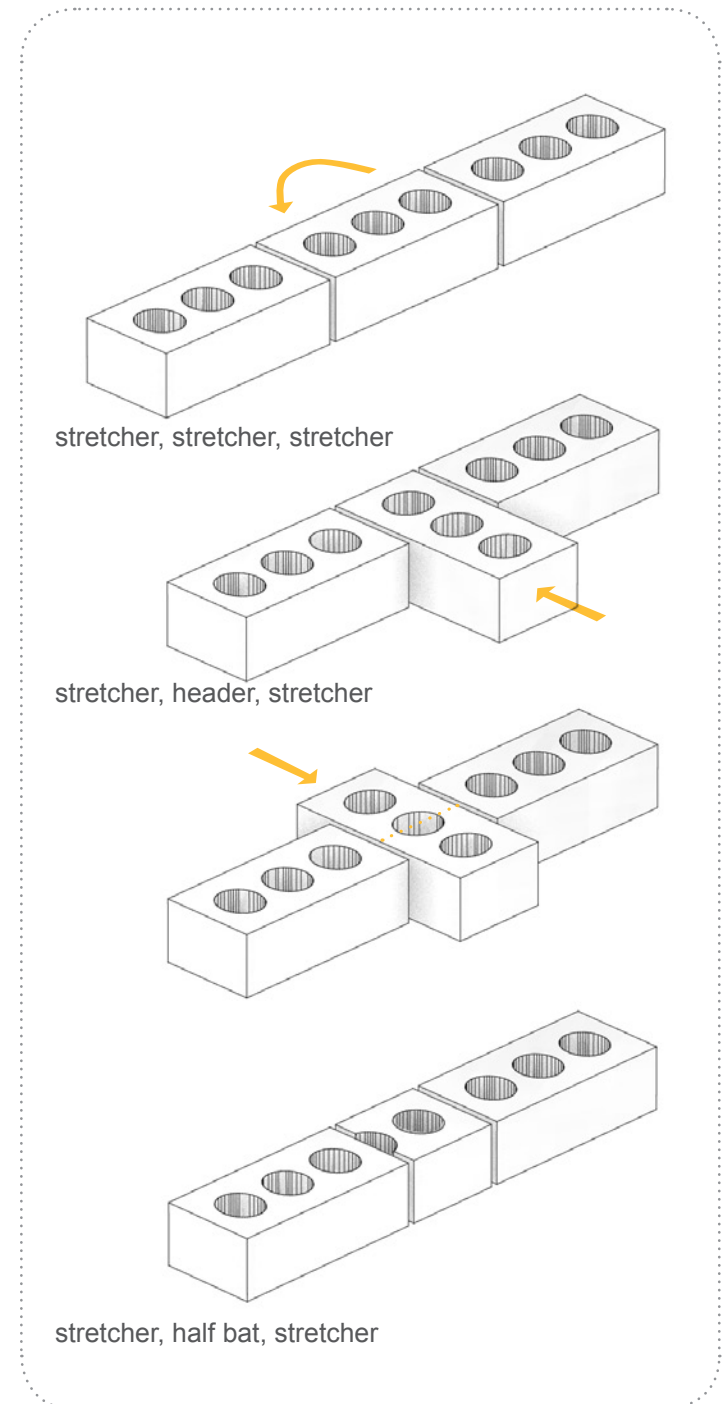

Figure 12: Three bricks in a row

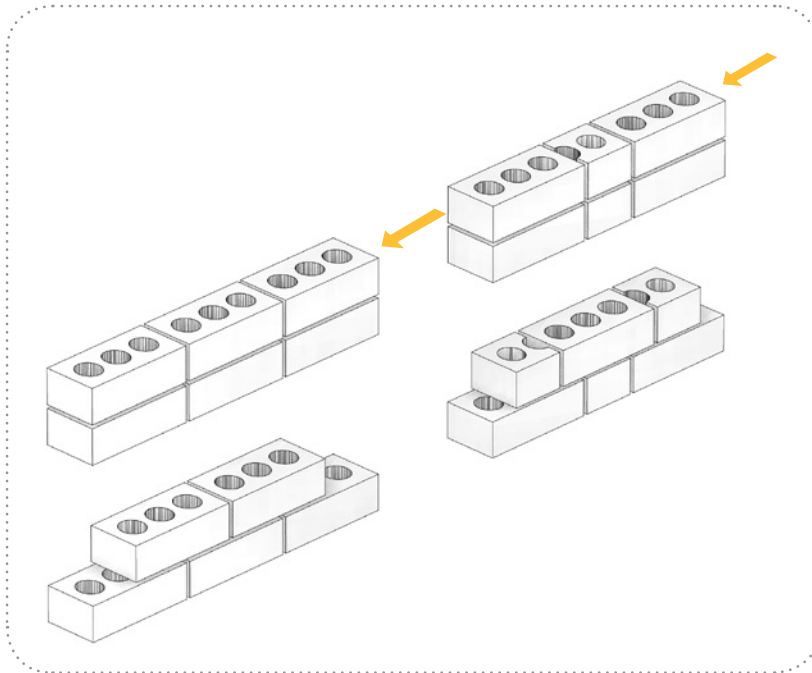

Figure 13: Shifting the top course

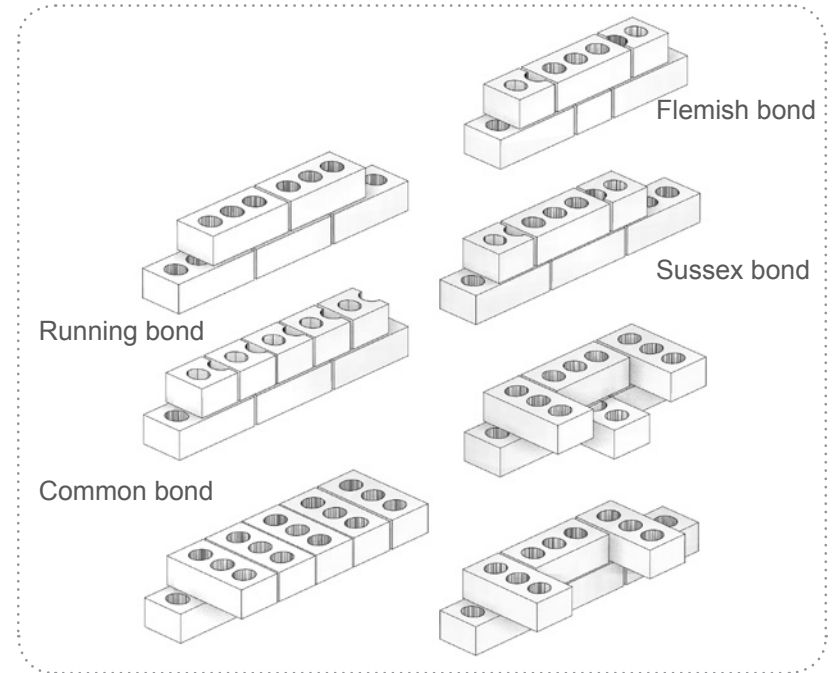

Figure 14: Various brick bond patterns

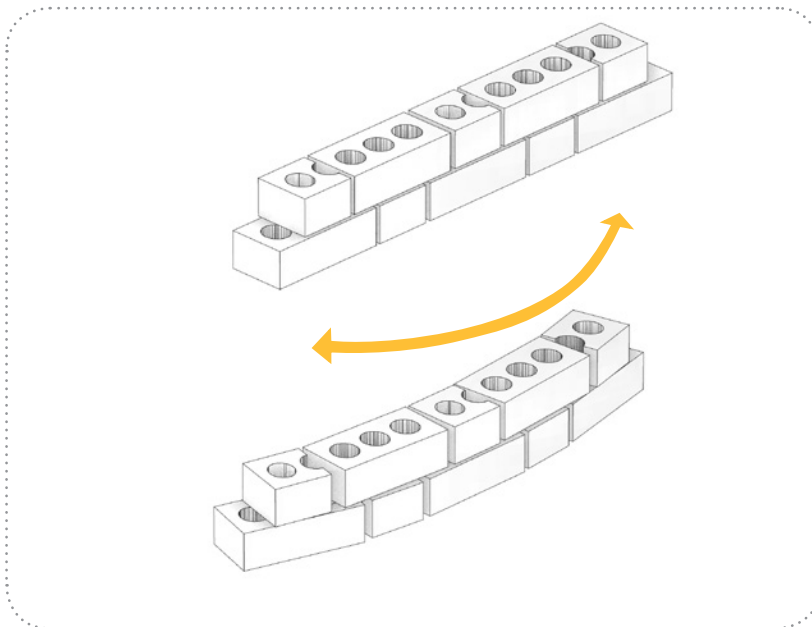

Figure 15: Creating curved forms

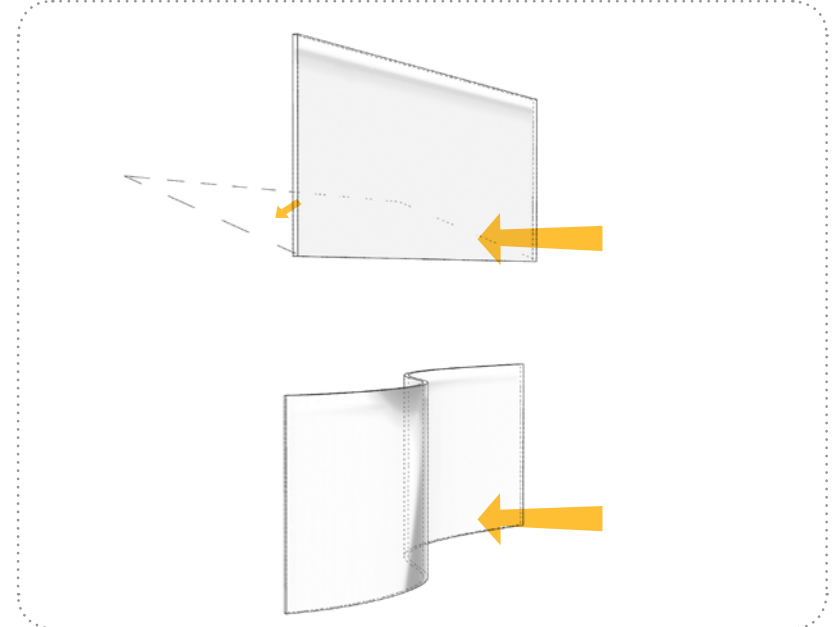

Figure 16: Self-lateral resistance

3.3. PATTERNS, FORMS AND OPENINGS

In a brick wall that is made of one layer of brick, some types of bonding patterns allow for creation of openings. The rule of thumb for creating the openings is that the top span of the opening can't be larger than a brick and all the collar joints should overlap with the bricks below them. Adding the openings turn the wall into a screen and allows for light and air to penetrate through the wall (figure 17).

Considering historic examples demonstrate the capacity of brick in creating flexible forms, patterns and openings (figure 18). Inspired by these historic precedents, this research uses computational assessment to propose a method for designing masonry brick walls that can have flexible forms, patterns and openings. By creating diagrams that clearly show the layout of the masonry system and methods for assembly, less skilled masons will be able to create more complex, responsive forms and patterns.

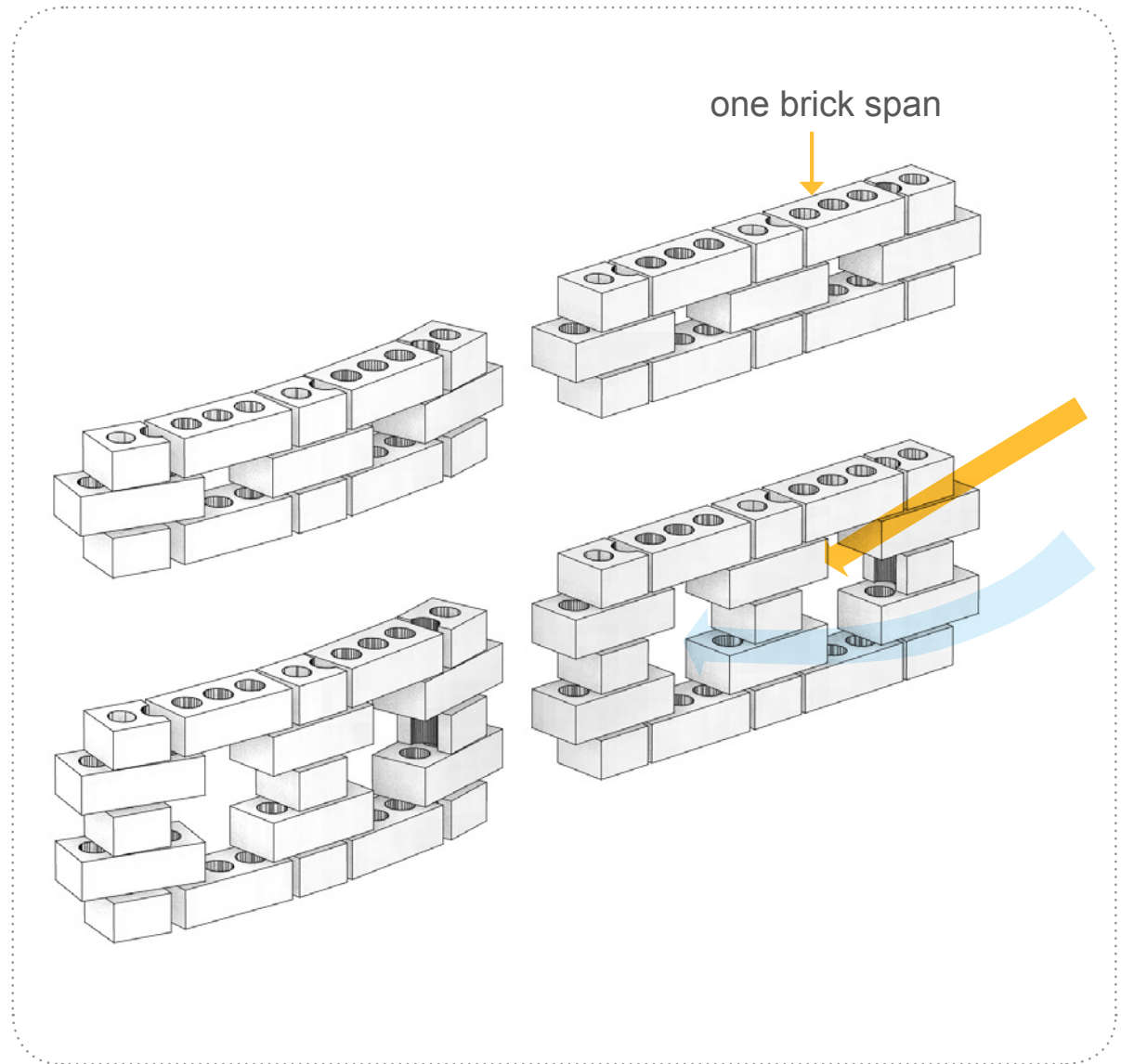

Figure 17: Creating openings

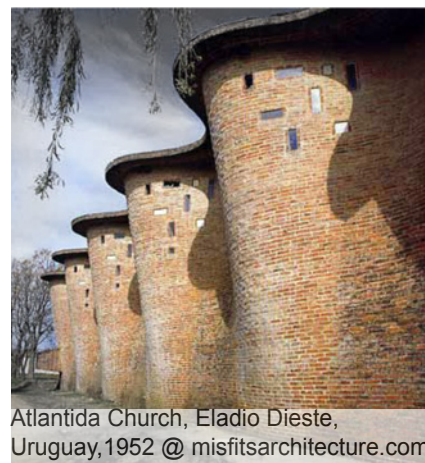

Figure 18: Historic and contemporary examples of brick structures

As seen in the examples brick can create both load-bearing and non load-bearing systems (figure19 and 20). The load-bearing brick walls are usually thicker than one layer of brick and can act as the main structural system of the building. Non load-bearing brick can be act as a self-supporting structure or as an infill or decorative element in a building facade.

The focus of this thesis is to study the design and construction process of a self-supporting, single-layered brick wall that can have flexible forms, patterns and openings. The properties of this wall will mainly depend on brick dimensions, mortar thickness, brick type and the type of bonding. Based on the bonding pattern the wall can be designed with different types of patterns and openings. Openings create a screen which can act as a transitional element.

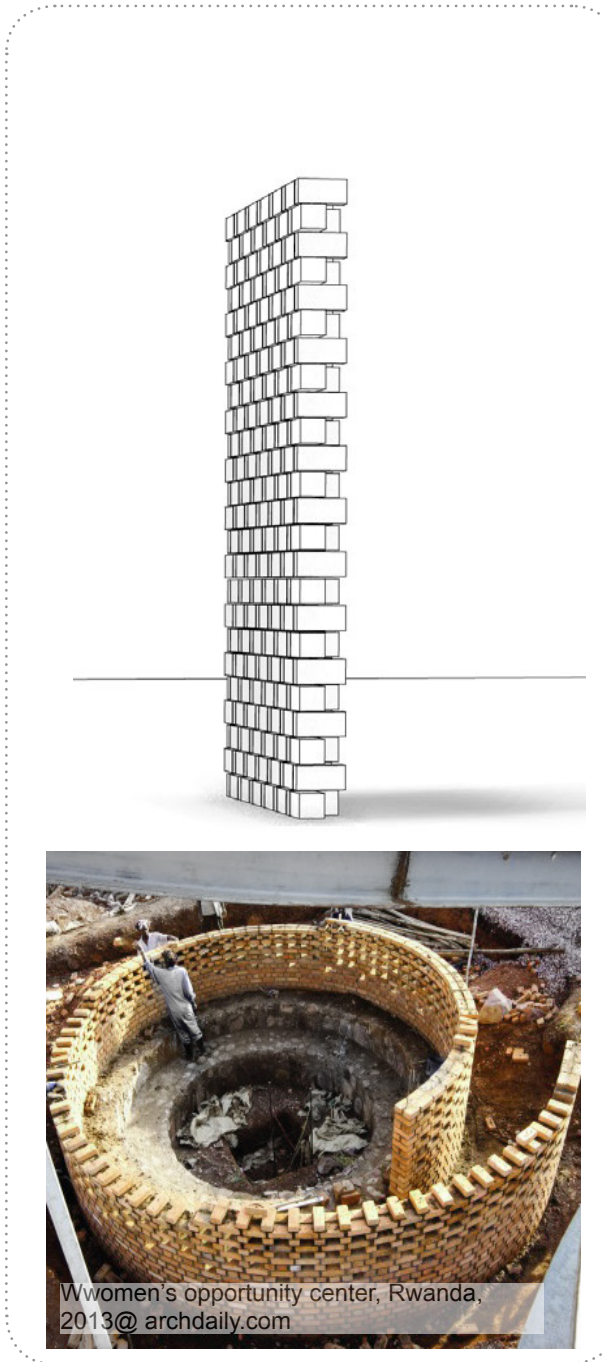

Figure 19: Single-wythe brick wall



Figure 20: Multiple-wythe brick wall

PART FOUR: SCREEN, A TRANSITIONAL ELEMENT

In a living structure, mechanical forces modify the form of the structure through 'direct adaptations'. these adaptations are directly related to the problem of inheritance which limits the ability to adapt¹³. in the same way in forming a building element, the designer can consider the mechanical forces like building load and environmental forces like sun and wind. The structure can be designed and built based on location-specific criteria and limitations caused by the material properties. In the case of formation of a bone in a body, mechanical properties of the materials it is made of, the forces it has to resist, and the strength it should have form the organic living parts¹⁴ (figure 21). In the case of a building although the pieces are not living, the initial formation has to respond to various forces which also deform it through time. The more the designer can consider and respond to these forces, the better the structure can perform and live. The forces forming the bone skin or an efficient building element, are formed and connected in response to external and internal forces.

A screen, with its breathing holes, provides a platform to test issues of energy performance and occupant comfort based on its response to natural light, view and air. This approach makes it possible to explore the potential of creating adaptive screen systems. Adaptability in architecture allows building to change their behavior in response to real-world events, and therefore offers context-aware performance.

¹³ Thompson, Darcy, *On Growth and Form*, (Cambridge University Press, 1992), p221.

¹⁴ Thompson, Darcy, *On Growth and Form*, (Cambridge University Press, 1992), p223.

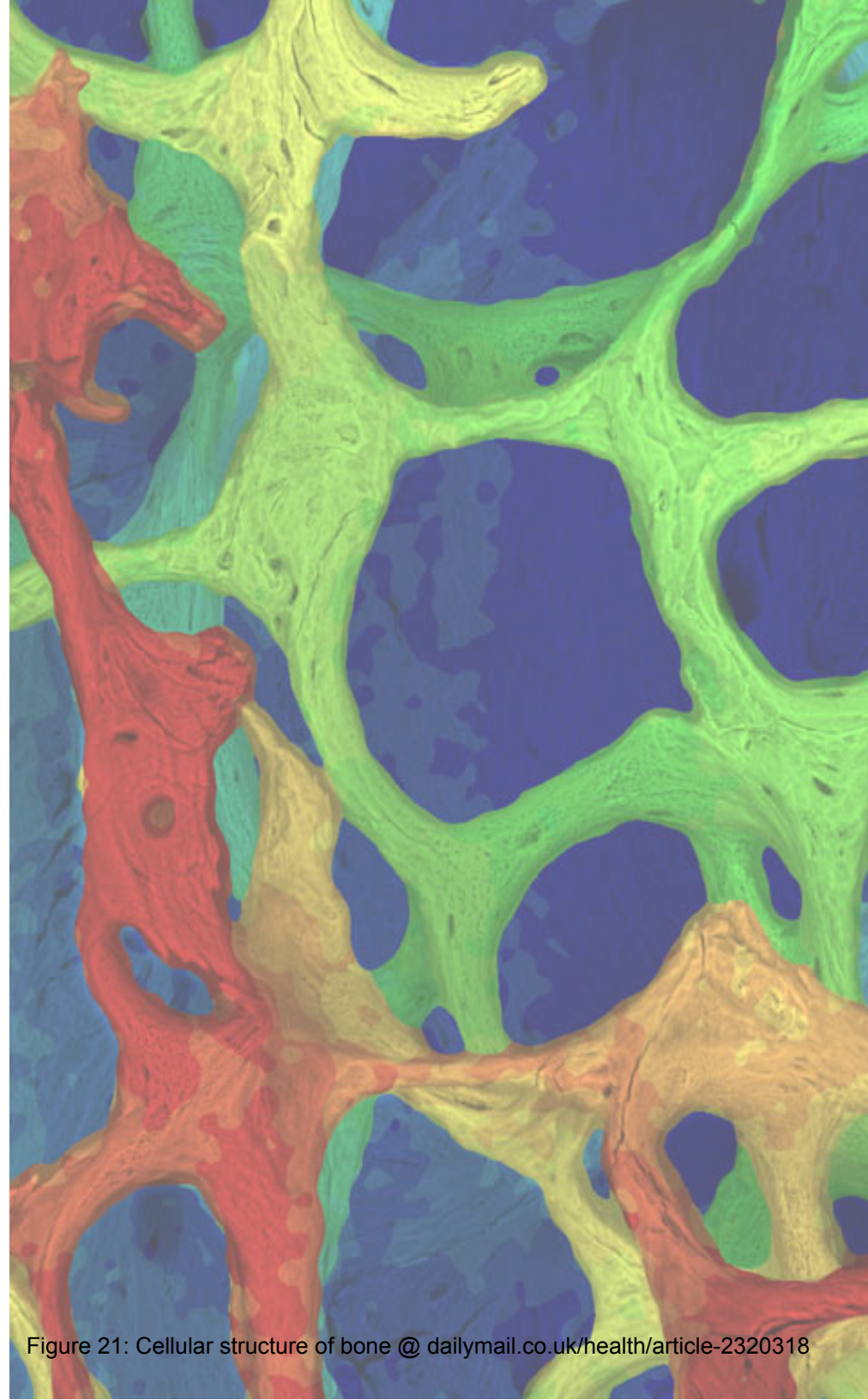

Figure 21: Cellular structure of bone @ [dailymail.co.uk/health/article-2320318](https://www.dailymail.co.uk/health/article-2320318)

A single layered brick screen can act as a transitional element in the interior space, exterior space or in-between the interior and exterior space. The patterns and openings can let the light and air pass through the screen based on the design intentions. The design and building process of such a system can be a challenge for the designer and mason because of the complexity in controlling each brick during the design process and the difficulty in understanding how to construct a complex pattern/ wall form.

Adaptability in architecture can be achieved through the sensible employment of vernacular design elements and creation of passive building skins which can respond to various environmental conditions. A brick screen should be designed according to the properties of brick and work well for the condition it is built in. Prudent choice of local material and construction systems can extensively reduce the cost of such systems. By applying advanced computational methods (high-tech) to already existing building assembly techniques (low-tech), the designed elements can create systems that better respond to the environment without imposing the need for inclusion of costly components which necessitates high-maintenance.

To demonstrate this process this thesis uses grasshopper to develop a design process to test and visualize brick masonry screen design ideas in an early design stage. This brick screen is made of one layer of brick and can have flexible forms and patterns (figure 22 and 23).

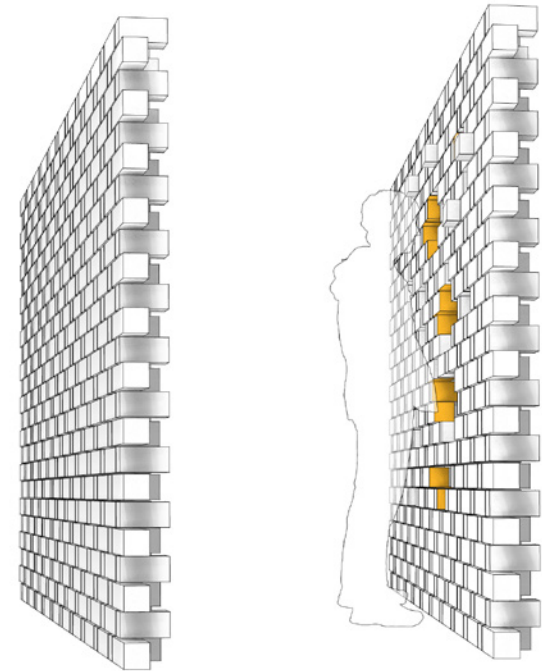

Figure 22: Creating a screen from a flat brick wall

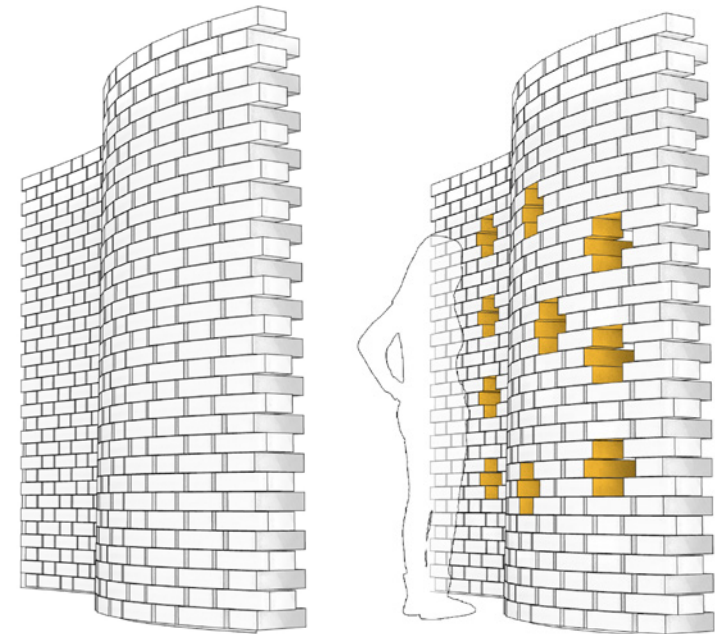

Figure 23: Creating a screen from a curved brick wall

PART FIVE: A PARAMETRIC DESIGN APPROACH

In order to use parametric design for creating a brick screen system, the first step is to understand which aspects of the design and building process can be improved using algorithmic design. These parametric approach should be applied to both the design and the construction process of a brick screen system.

5.1. WALL FORM

This first complexity in designing a brick screen is in creating a 3D representation of the wall according to the properties of brick and mortar, specific to each location. Modeling each brick and copying them to make a 3D model of a wall can be a very time-consuming and laborious process. Creating flexible wall forms makes this process much more complicated. It is almost impossible for a computer user to turn each brick in the right direction in the 3D modeling space to create a particular type of curvature. This is why this thesis use parametric design to let the user quickly and easily go through this step and model walls with different forms just by inputting the brick size and mortar thickness and picking a surface for the wall form (figure 24).

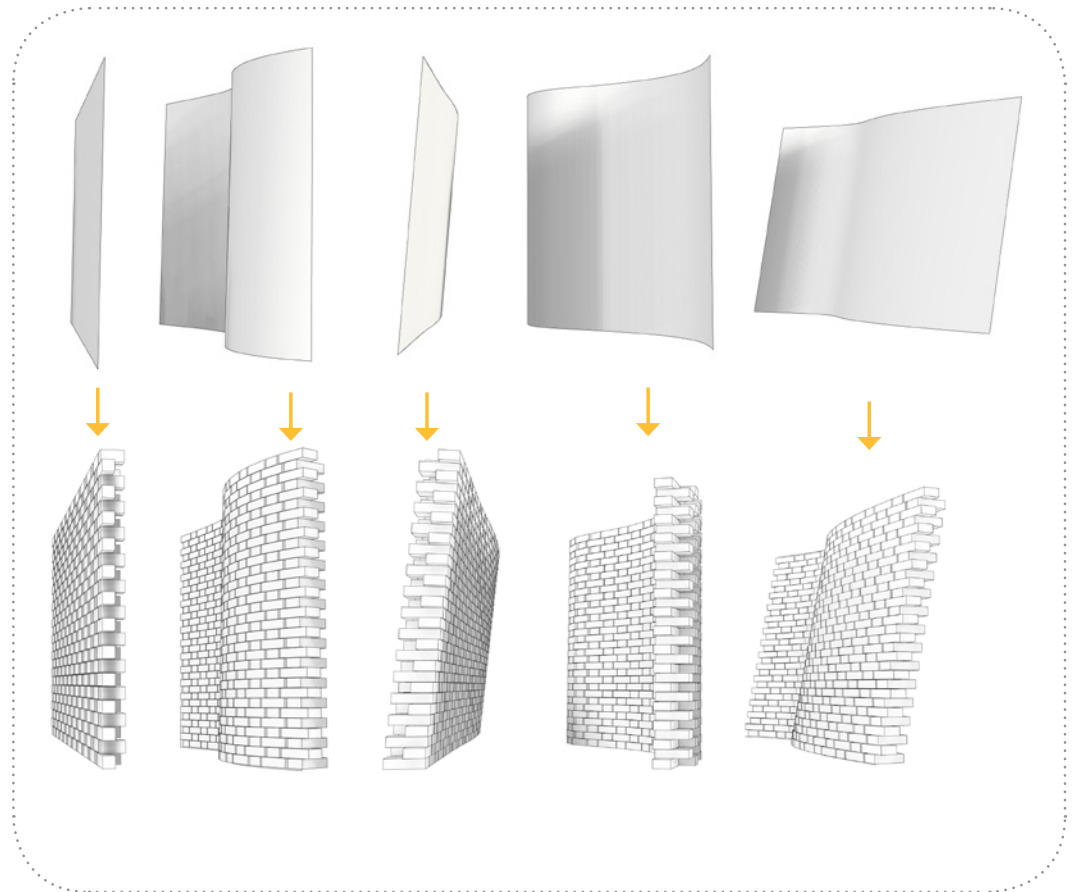

Figure 24: 3D modeling brick walls with different forms

5.2. PATTERN

Patterns add another level of complexity to this process. A parametric pattern making approach lets the user quickly create various patterns and edit them without the need for redrawing each brick. The designer becomes the mason and can control and place each brick in a desired location and remove it or change its orientation to create different patterns (figure 25).

5.3. COLOR

In order to represent a visualization that is closer to reality, the bricks can be shown in colors that make them look like real bricks. The user can parametrically change these colors anytime during the process and go back and forth between options (figure 26).

5.4. THE SUN

In the digital world, the user can simulate the environment of any location and design forms and patterns that work well for that climate. The option for observing the sun position in different times of the year allows the user to consciously place bricks considering the effect of their shadows (figure 27).

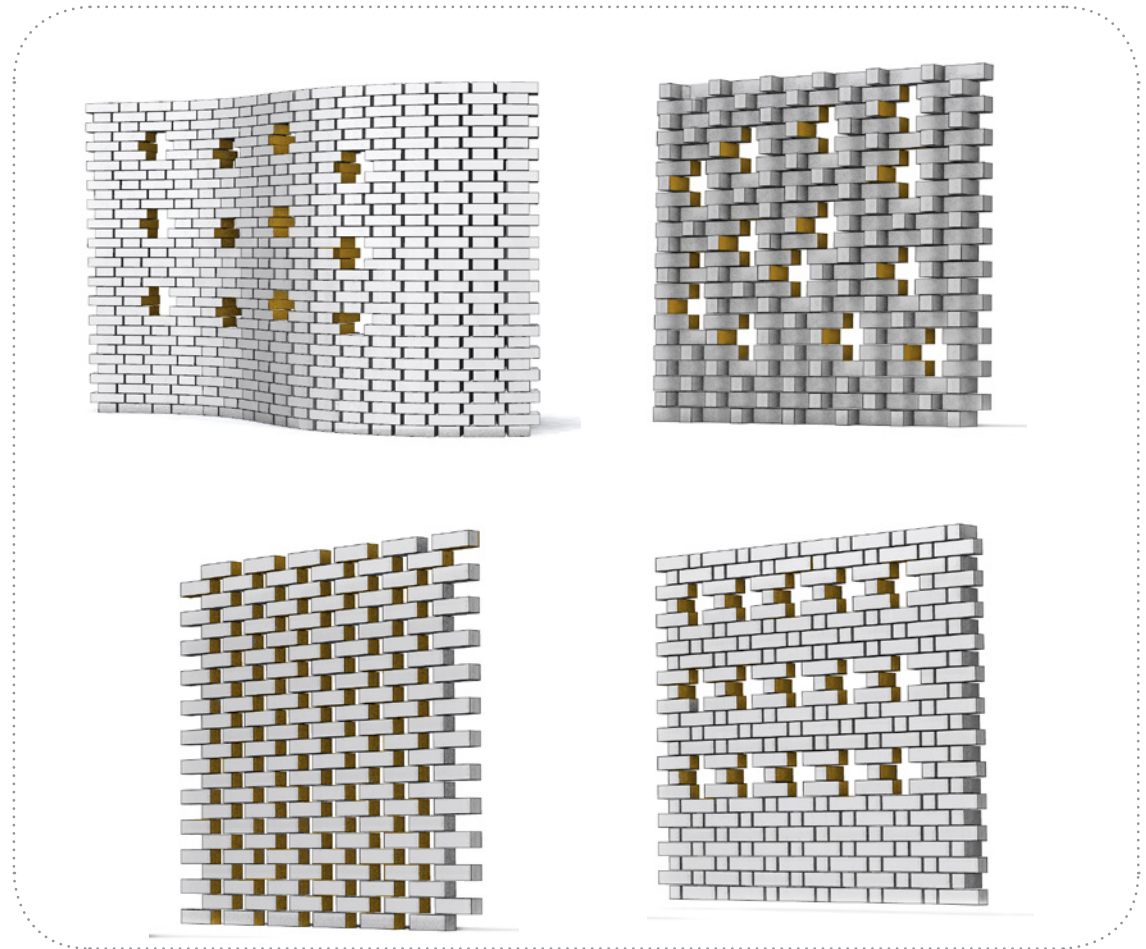

Figure 25: Add patterns to the wall



Figure 26: Add color/Material to the wall

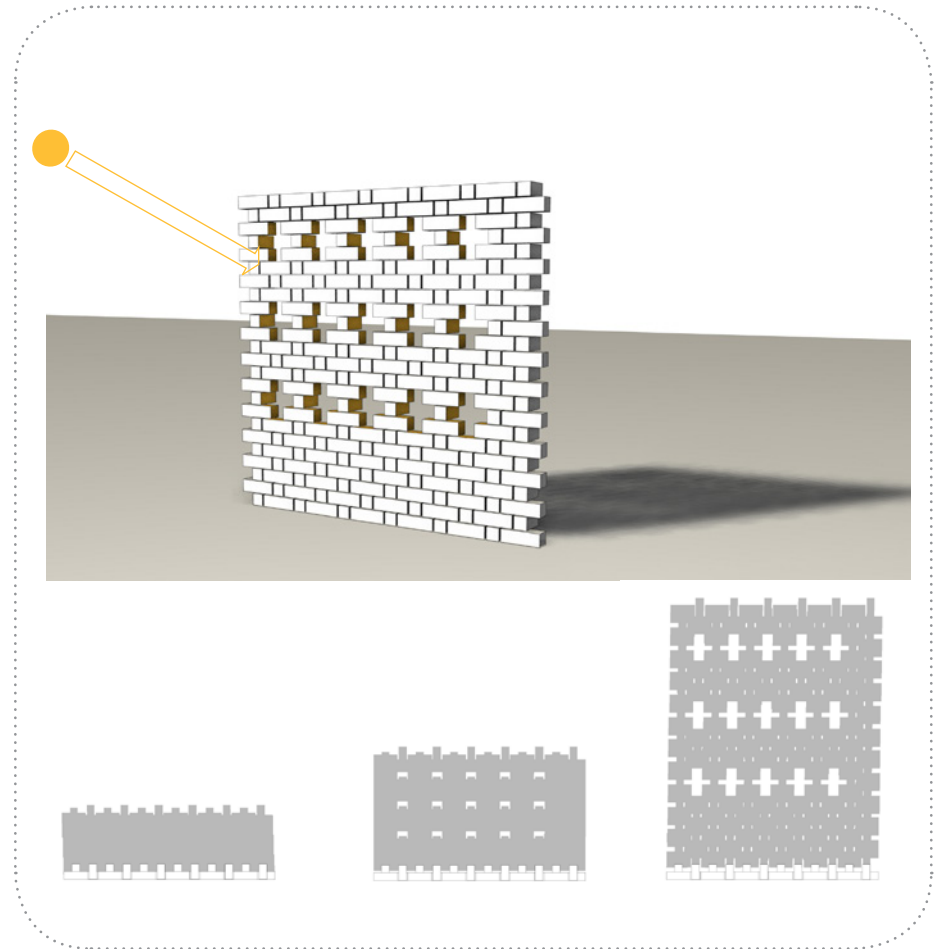

Figure 27: Study the sun

5.5. CONSTRUCTION PROCESS

In more recent projects, parametric design and digital technology has been used in various ways to create innovative masonry systems. One example is in the area of robotic fabrication and form-finding for complex masonry fenestration systems. This linkage results in high precision of the fabrication process¹⁵. Over the last decades Numeric Control (NC) and robotics have become firmly grounded within architectural practice¹⁶. The research methodology for these approaches is often heuristic and experimental. Robotic brickwork developed by Swiss architects Gramazio and Kohler Pike Loop project in New York is one example of such systems (figure 28). Gramazio and Kohler used a complex robotic system which included a programmed robotic arm to create a non-uniform pattern across the entire facade of their Gantenbein Winery project¹⁷.

Another example for direct implementation of digital design and fabrication is creating 3D printed bricks. Each 3D printed brick can have a particular shape. Each shape can be part of a bigger system and the bricks can interlock to create a specific form (figure 29)¹⁸.

15 Pavlíček, Jiri; Kaftan, Martin, "Parametric Design System for Passive Houses," Proceedings of the 30th eCAADe Conference, 2012.

16 Feringa, Jelle, "Implicit fabrication, fabrication beyond craft: the potential of turning completeness in construction," ACADIA pp. 383-90, 2012.

17 Gramazio and Kohler, Architektur und Städtebau.: 2013. Gantenbein Winery project. accessed Oct 10, <http://www.gramaziokohler.com/>.

18 3-D printing helps designers build a better brick, accessed Sep 10, <http://www.news.cornell.edu/stories/2014/07/3-d-printing-helps-designers-build-better-brick>.

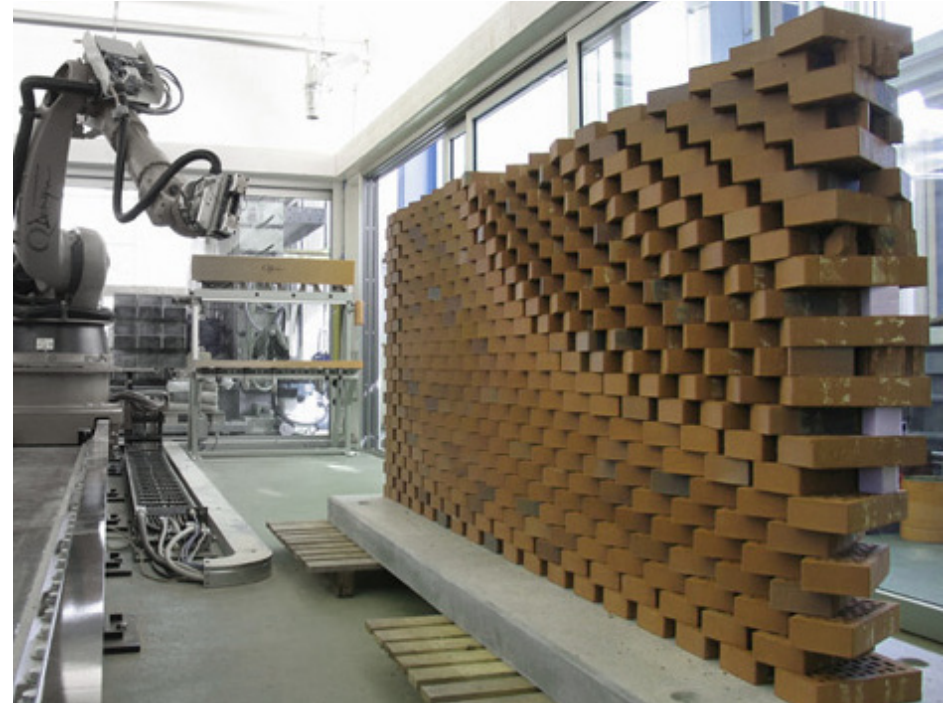

Figure 28: Robot Mason@<http://www.gramaziokohler.com/>



Figure 29: 3D printed bricks, <http://www.news.cornell.edu/stories/2014/07/3-d-printing-helps-designers-build-better-brick>.

The high precision in both of these systems is achieved through highly complex tools and by direct link between the digital design and fabrication process. This category of innovative masonry systems necessitates complex fabrication processes. These approaches result in the creation of a complex, generally expensive innovative design which might not be economically viable for ubiquitous use. These systems require not only advanced computational technology during the design process, but also mandate costly high-tech fabrication and technical maintenance. The price and complexity of these systems means they are available to use only in a few locations in the world and those locations are not necessarily where earthen construction is dominant (figure 30). In places with limited access to such cutting-edge technology, access to digital fabrication is limited and very expensive. Therefore finding an easy and cheap method of communication with the masons which is less precise and relies on human labor can be more useful than relying on digital fabrication (figure 31).



Figure 30: Global access to robot mason or 3D printing versus the prominence of earthen architecture in the world

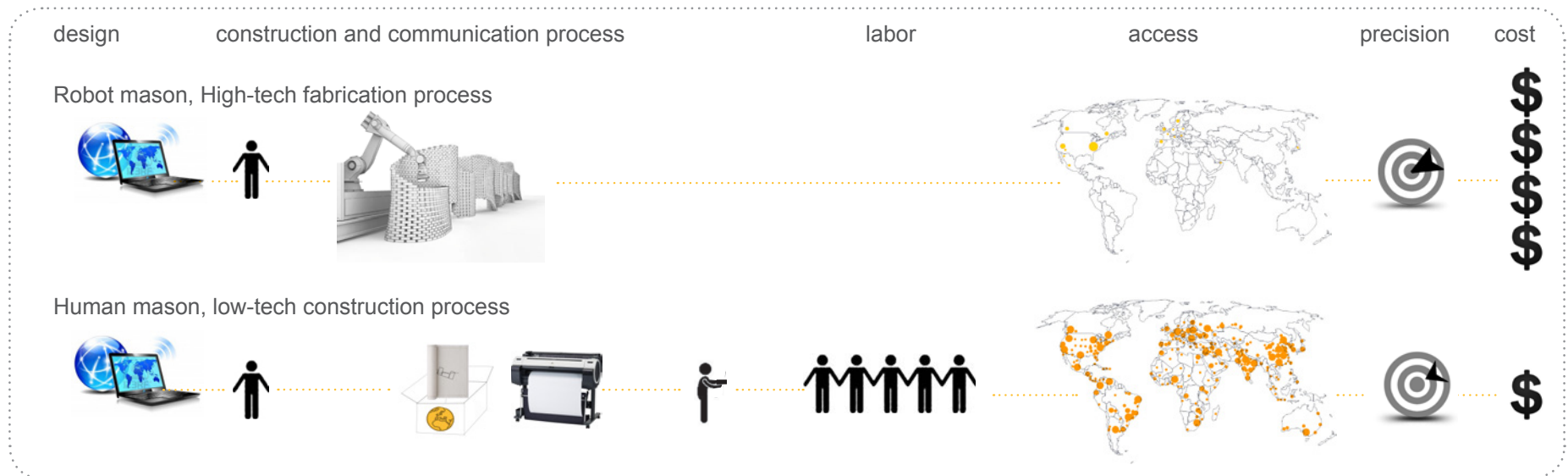

Figure 31: Robot mason versus human mason

Creating simple guides instructing the mason on the assembly of the brick screen system, as opposed to using robot masons or 3D printers for construction, can be a more cost-effective and globally applicable solution. While designing a brick screen system the designer can use parametric tools to create guides, renderings and diagrams that tell the mason how to go through the process step by step (figure 32).



Creating flexible wall forms, designing patterns, visualizing bricks with various colors, understanding the sun while designing and creating construction guides are the parametric steps that this thesis proposes for designing brick screen systems. Here the parametric high-tech design space helps the designer create a more responsive, high-touch low-tech system (figure 31).

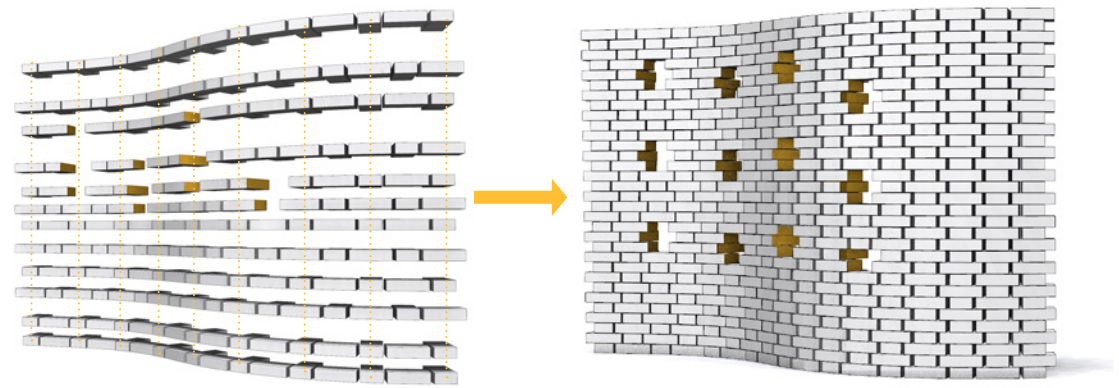
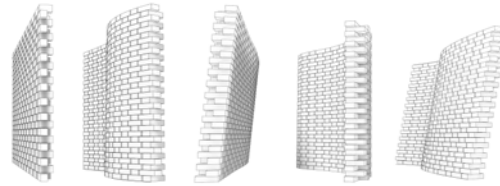

Figure 32: Guiding the mason



low-tech

high-touch



flexible wall form

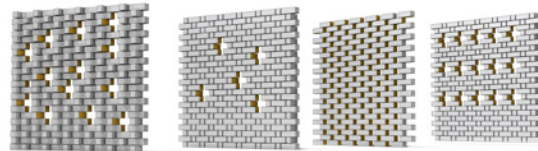

pattern

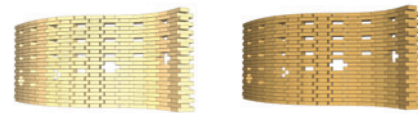

visualization

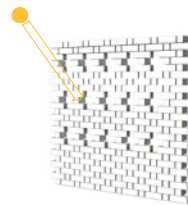

the sun

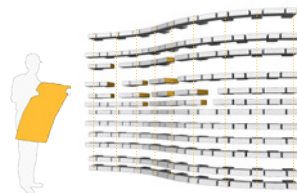

construction guides

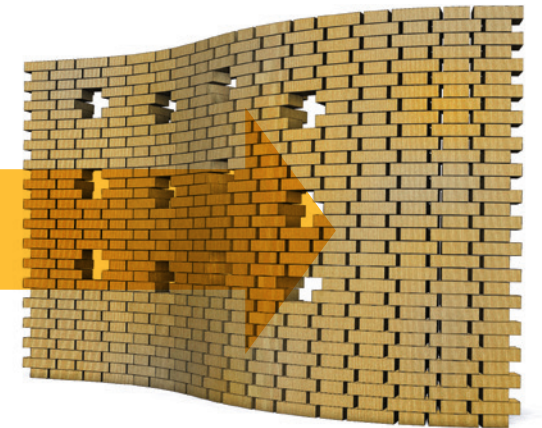

high(low)-tech

Figure 33: Low-tech/high-touch

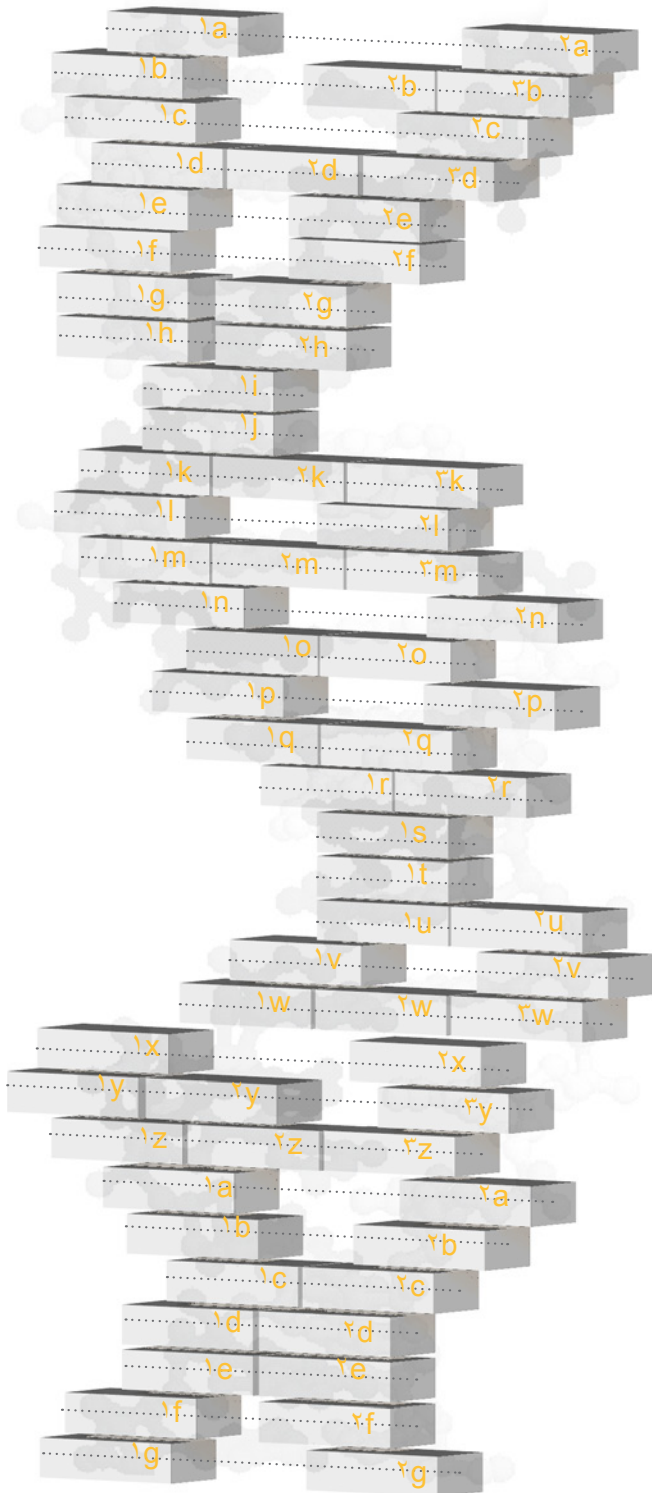

Figure 34: DNA Brick assembly

PART 6: THE PROCESS: DNA-BRICK ASSEMBLY

The nano-fabrication technique, called “DNA-brick self-assembly,” uses short, synthetic strands of DNA that work like interlocking Lego bricks. It capitalizes on the ability to program DNA to form into pre-designed shapes¹⁹. The same process can be applied to the design and construction process of a brick screen system (figure 34). Various design criteria based on the information that the designer gathers, should be considered to create a parametric workflow that helps the user design more efficient solutions. Such criteria do not necessarily agree and sometimes stand out against each other. For example improving energy efficiency and reducing consumptions by the use of daylighting can prove to be troublesome due to the many and often contrasting performance parameters a designer faces. Therefore, the methodology should perform based on a desired hierarchy defined by the designer and the community.

The way bricks are put next to each other in a brick screen system can be customized according to location-specific information. Similar to the structure of a DNA, the information can inform the organization of the screen system considering the role and importance of each factor (figure 34). This information includes factors like the geographical location, the form and orientation of the wall and the brick sizes. Another important aspect to consider is the aesthetics of the screen and the influence of cultural patterns in creating possible design solutions. The tool developed in this thesis uses brick, as a common building material, to create less common assemblies in which the wall form; brick to brick connections; and openings of the wall system can respond to environmental forces.

¹⁹ DNA Assembly, accessed Jan 10, <http://wyss.harvard.edu/viewpage/409/>.

This thesis uses Rhino, Grasshopper and Ladybug to create a *DNA brick design workflow* (figure 35). Grasshopper is parametric design software developed as a graphical algorithm editor tightly integrated with Rhino's 3-D modeling tools²⁰. Ladybug is a highly optimized daylighting and energy modeling plug-in for Grasshopper and allows users to carry out a series of environmental performance evaluations during the design process²¹. Before using the workflow, the designer should gather the information that is needed to operate the tool. This information include the size of brick and thickness of mortar, size and form of the wall and size of the screen and location specific parameters including latitude, longitude and time zone.

The process is a parametric process and the relationship between the parameters and rules inform all the steps. The design process is interactive and the designer can go back and forth in between the design steps and adjust the initial inputs at any point.



Figure 35: Rhino/Grasshopper/Ladybug

Grasshopper components are usually hard to read and not

²⁰ Grasshopper, Algorithmic modeling for Rhino, accessed Nov20, 2013, <http://www.grasshopper3d.com/>.

²¹ Ladybug + Honeybee, accessed Nov20, 2013, <http://www.grasshopper3d.com/group/ladybug>.

reusable. Figure 36 shows a typical Grasshopper workflow. In this thesis, to make the process interactive and reusable by different designers, the grasshopper components are shaped in the form of clusters that clearly tell the user what the inputs and outputs of each step are. Also by adding diagrams to each component, the user can visually understand the step and input the right information (figure 37).

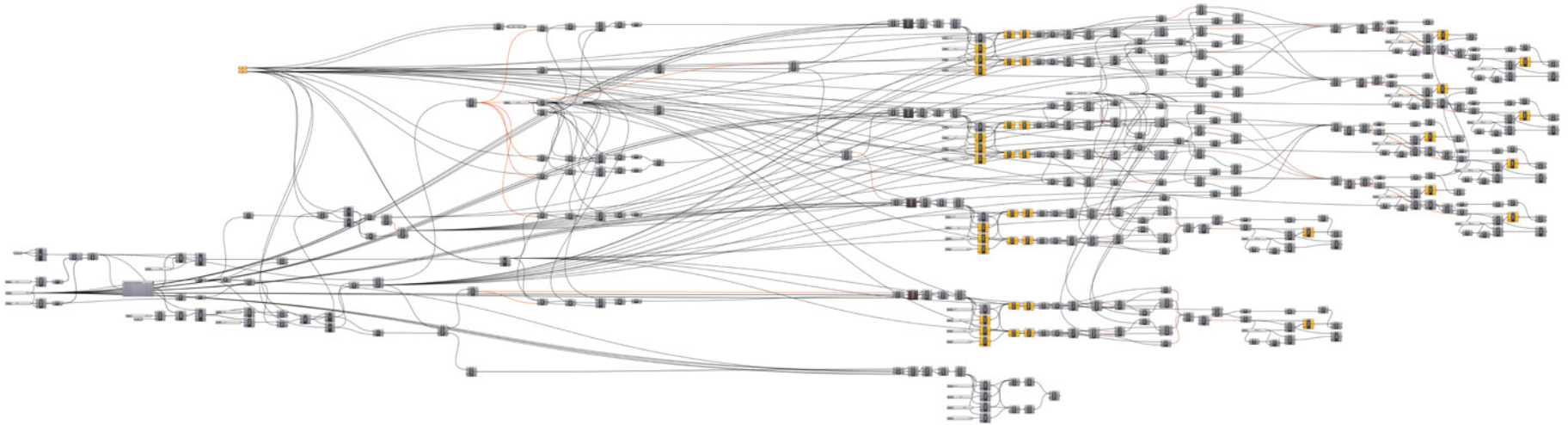

Figure 36: Typical Grasshopper work-flow

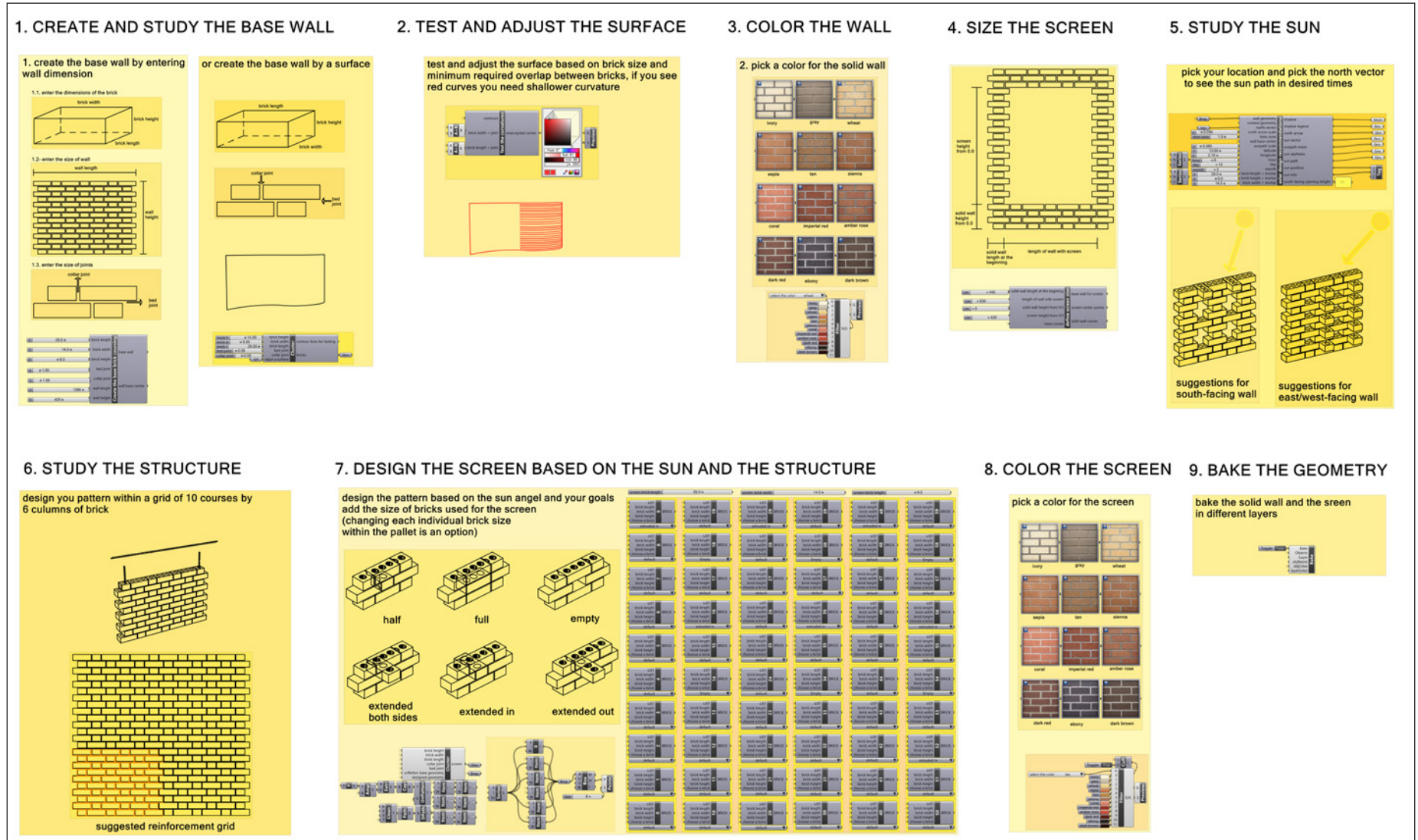

Figure 37: DNA assembly grasshopper work-flow

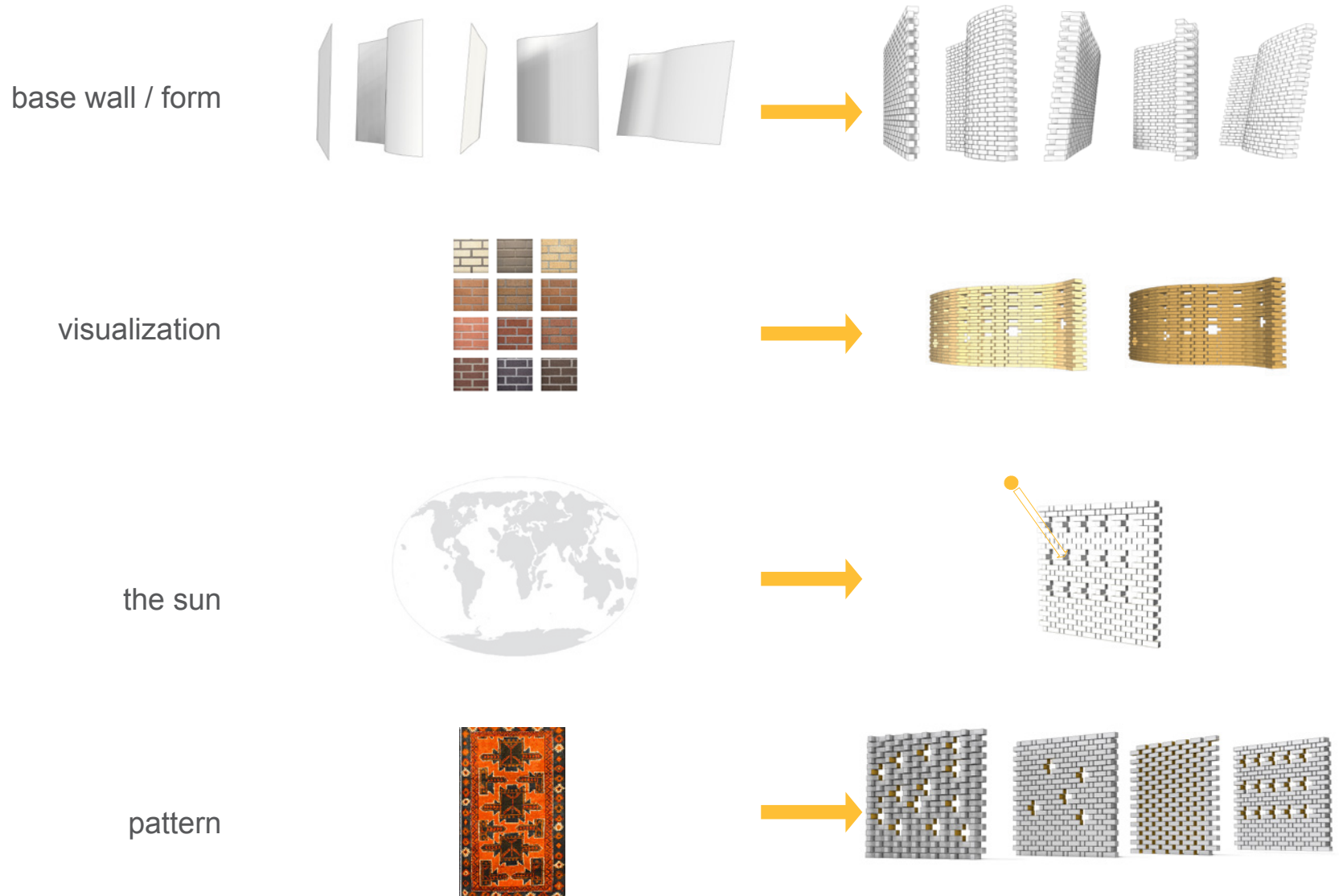

Figure 38: form/visualization/sun/pattern

6.1: DNA-BRICK ASSEMBLY: THE DESIGN PROCESS

As described in part five and six, the DNA masonry design tool helps in creating flexible wall forms, visualize the wall with different colors, understanding the sun while designing and designing patterns (figure 38).

The first step of the process is creating the base wall. This step is directly related to the type of brick bonding. In other words, each bonding pattern can create different types of brick screen systems. This thesis focuses on Flemish bonding, a common structural brick bonding pattern. Flemish bonding allows the user to create different types of openings. The structural tectonics of the bonding pattern helps the system to be self-supporting.

In the future steps of this research, the same process can be designed for other types of brick bonding patterns.

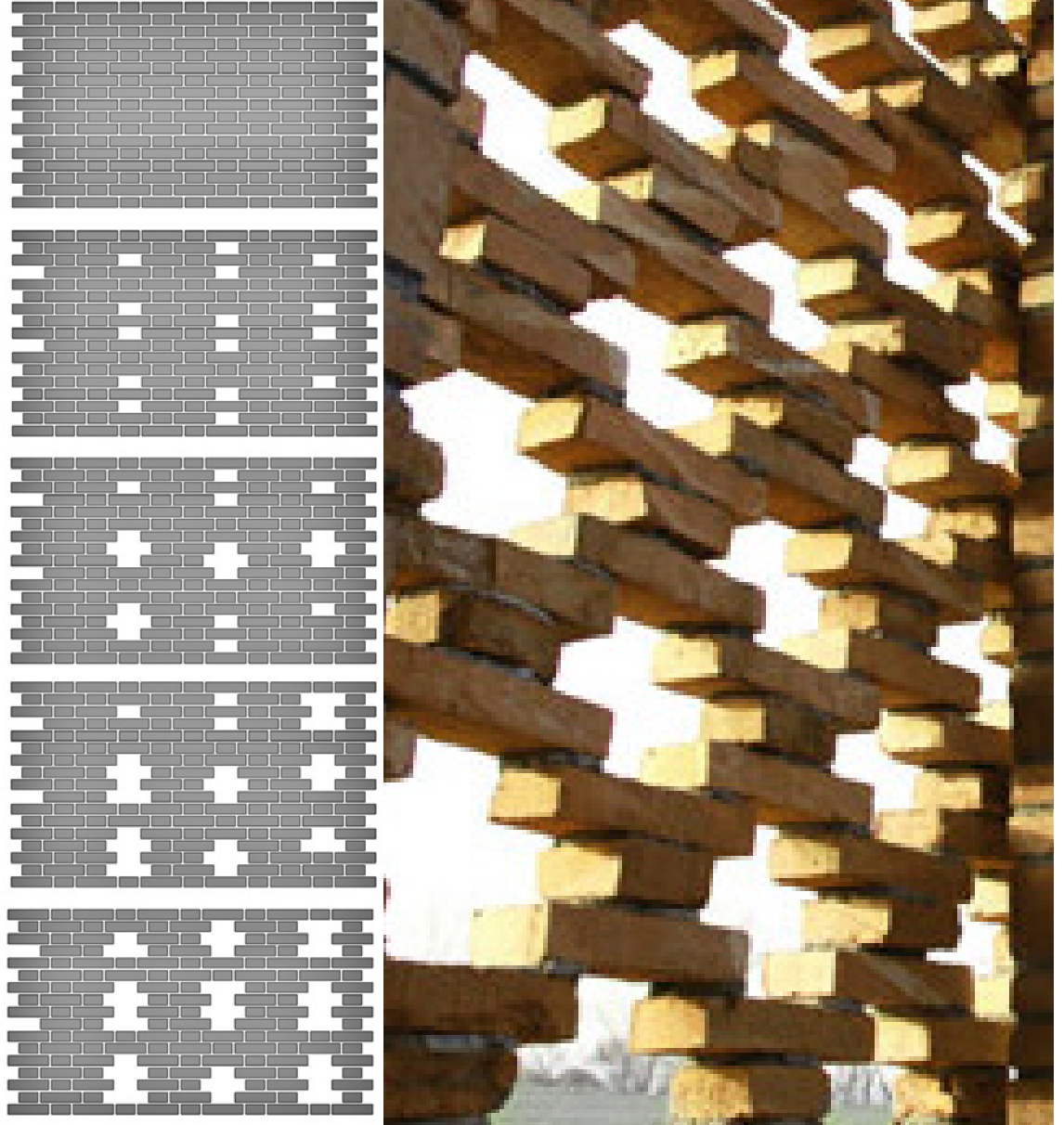

Figure 39: Flemish bonding

6.1.1. STEP ONE: BUILD THE WALL

The first step of the design process is to create the base wall for a brick screen. To define the form of this wall the user can create a flexible surface in Rhino environment and use it as an input for the component (figure 40). Another method is to define the wall length and wall height in the grasshopper component for creating flat walls .

The next step is to define the brick size by inputting its length, height and width. The last step is to define mortar thickness for both the bed joint and the collar joint. Once all these data are entered in the grasshopper component, the brick wall is created.

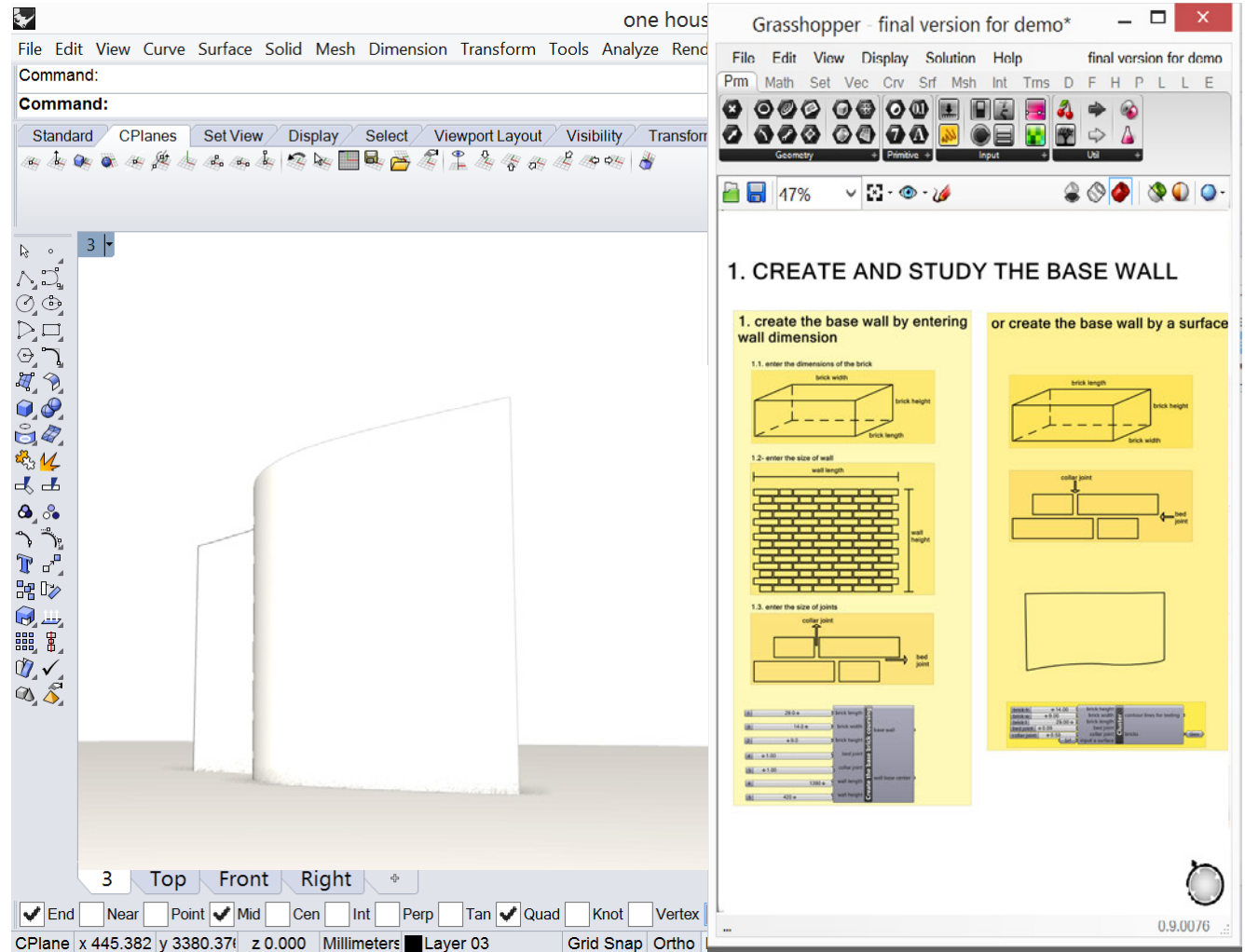

Figure 40: creating the base wall

In order to build a curved surface, there should be enough overlap between the bricks to have enough area for the mortar. Based on this requirement, it is possible to test the curvature of a surface and study whether it is constructible or not. This can be achieved by comparing the length of the centerline of three bricks placed next to each other in a row with the length of the centerline of three bricks in a row, each turned to create a curved form. Using the same methodology, the length of the centerline of bricks that are put directly on top of each other can be compared with the length of the centerline of the bricks that are pushed inwards or outwards on top of each other to create a vertically curved form (figure 41 and 42).

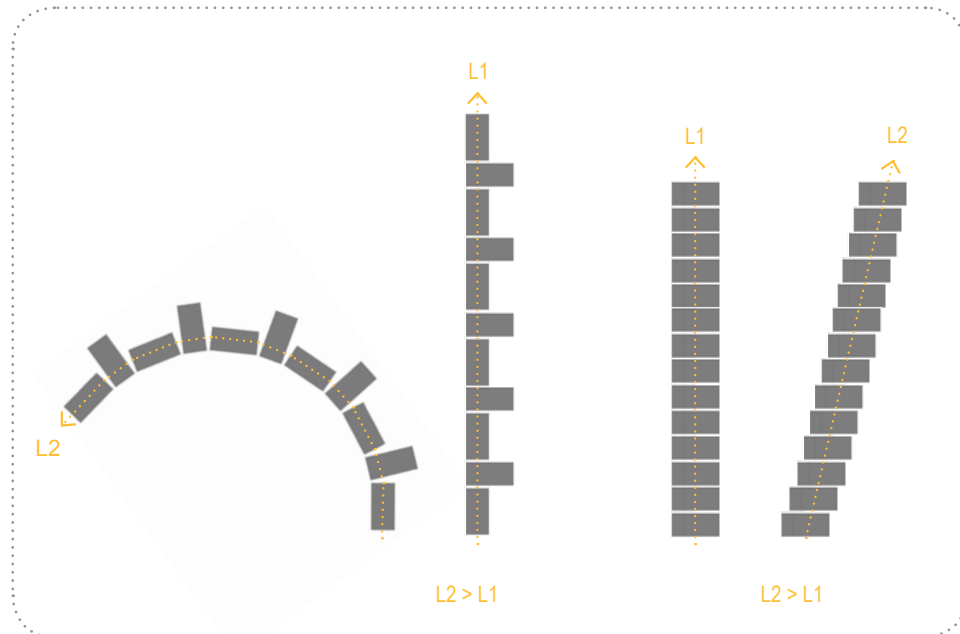

Figure 41: curving or tilting the wall

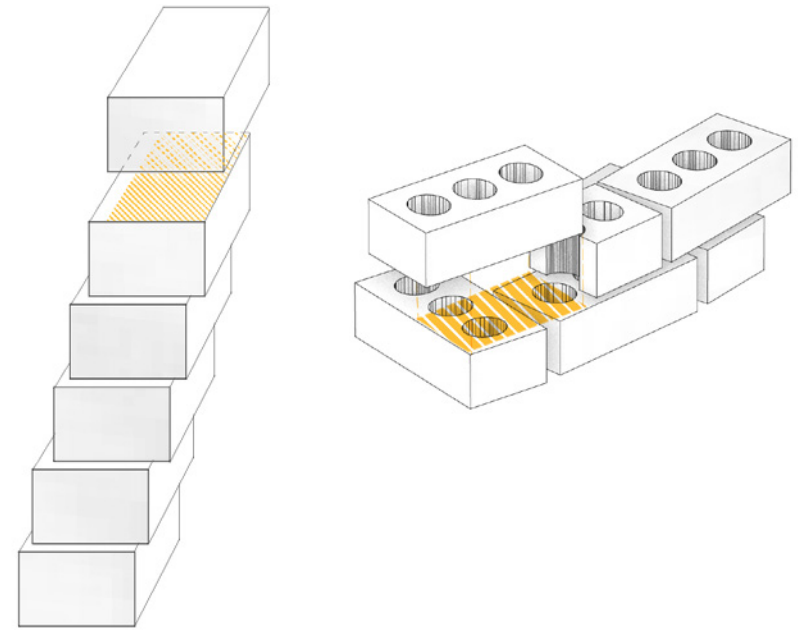

Figure 42: measuring minimum overlap between bricks

Based on the formula described in the previous page, one of Grasshopper clusters tests the curvatures of a surface and gives live feedback to the user. At first, the input surface is divided into a grid according to brick height, width and length. Then the length of each line on the surface is measured and compared with the length of a straight line with the same number of bricks. Based on this comparison if the curvature is too deep, the grid lines of the area become red. This means that the user should adjust the surface in the Rhino environment to create shallower curvatures in the red areas. After this adjustment, the surface becomes colorless if it meets the required measurement.

This is only an optional step for the user to study the surface that is created in Rhino. By changing the brick size the allowance for the depth of the curvature will change.

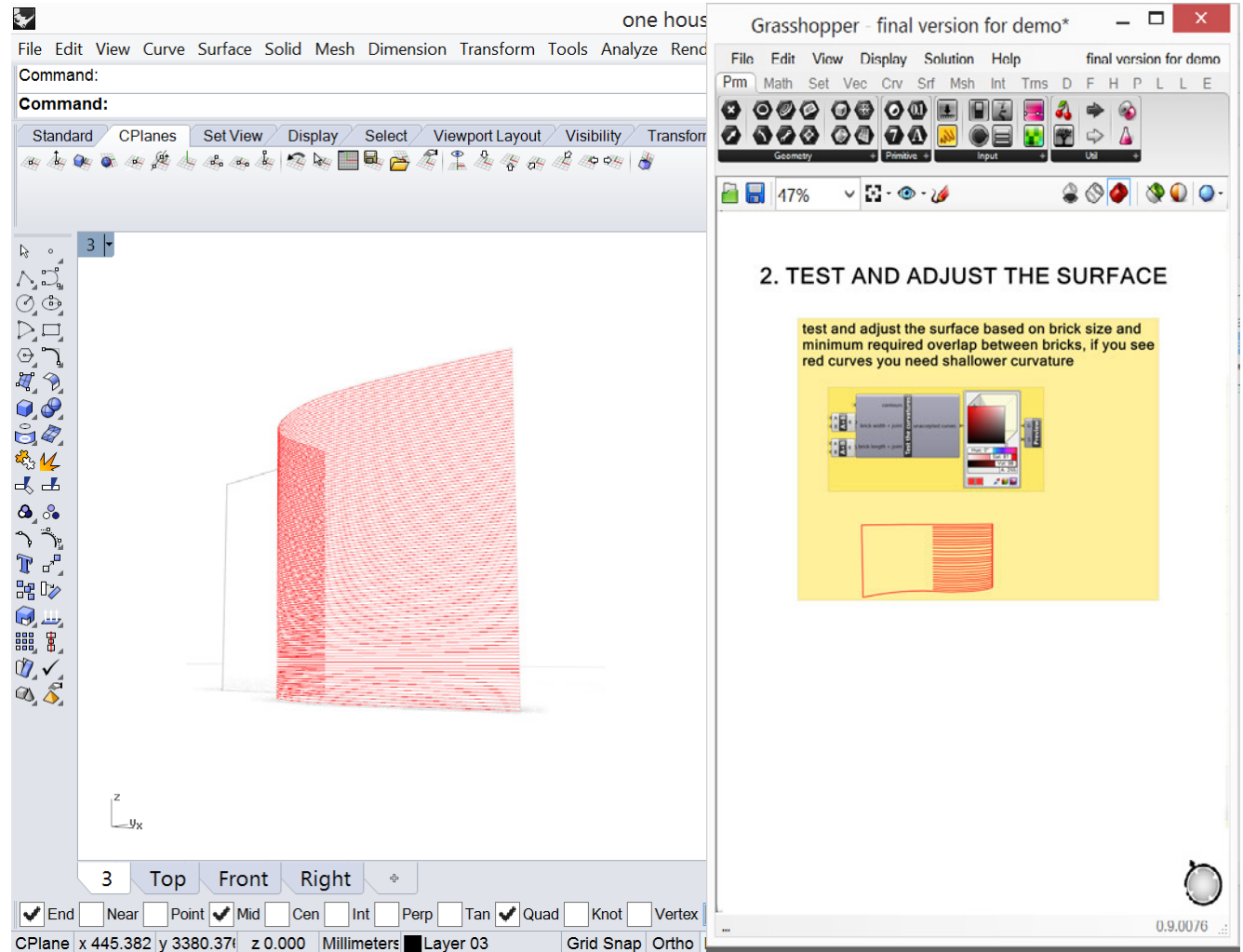

Figure 43: testing the surface

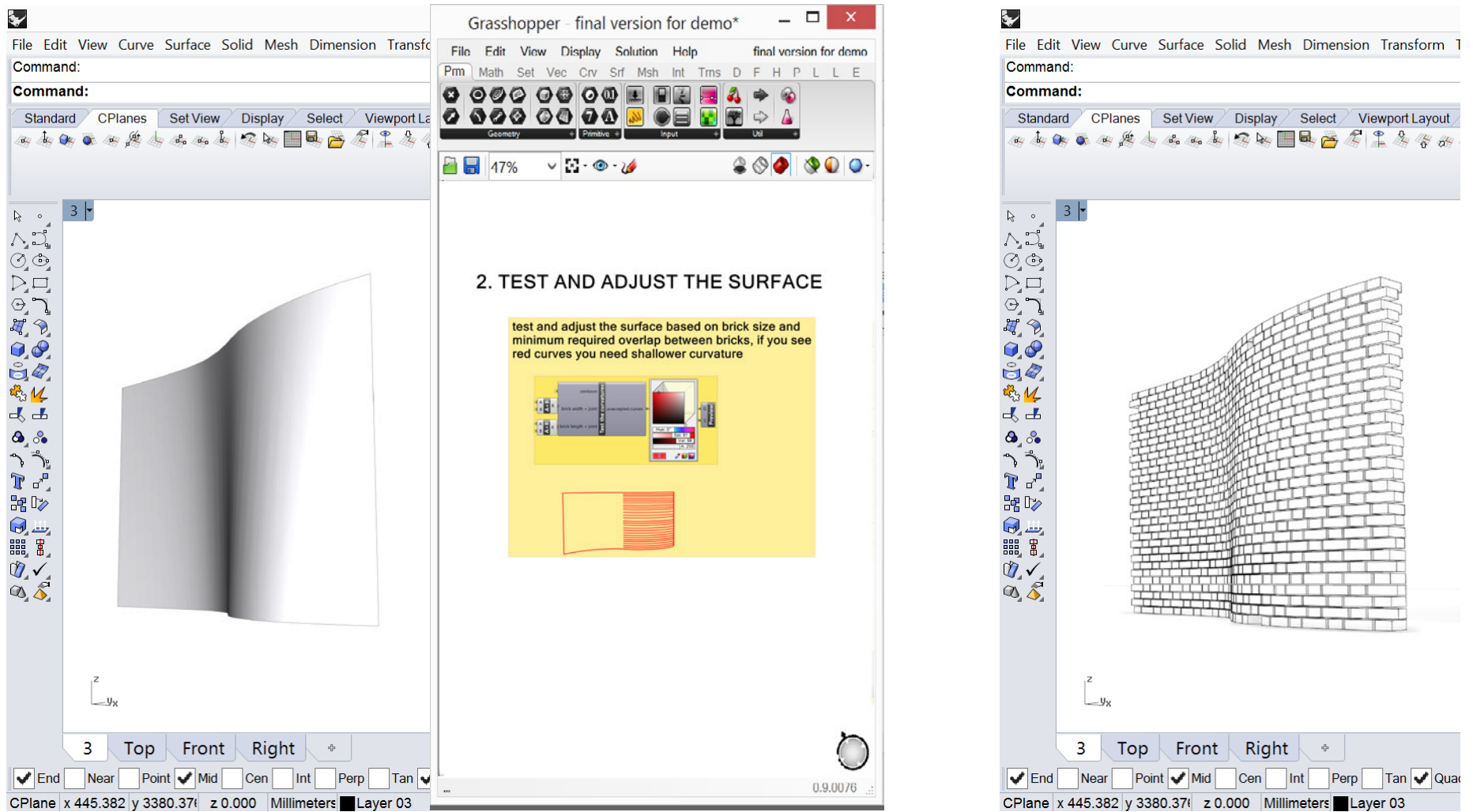

Figure 44: adjusting the surface to create the wall

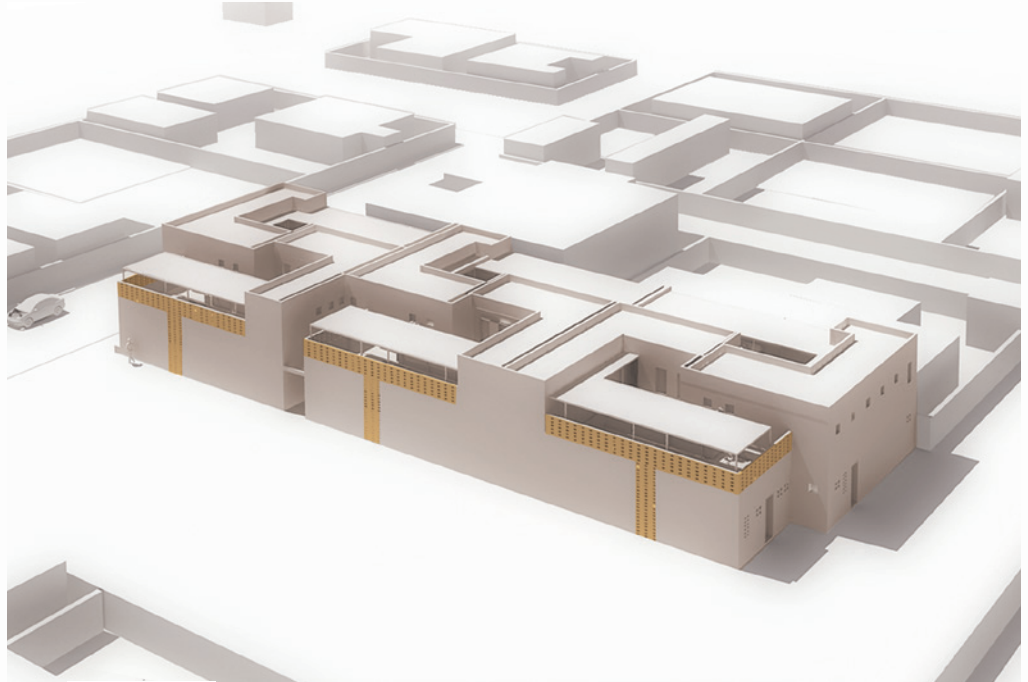

Figure 45: High-density housing project in Niamey, Niger

The next step of the process is to define the boundaries of a screen. Based on the design intent, the screen can have different sizes and can be part of a wall in a building facade or in the exterior or in the interior space. This step is explained using an example of a building facade in Niamey, Niger which is now under construction (figure 43). The bricks that are used for this building are 25 x 14 x 9 cm Compressed Earth Blocks.

As seen in the plan, each building has screens that are facing South, East or West. The South-facing screen can be divided to two rectangular surfaces. Each of these screens should be designed separately based on the design intent (figure 44). This process of dividing the irregular screen form to rectangular shapes can be similar for any design and will help in customizing the screens in different areas. It also works well for the construction process because the construction of each portion has to occur separately.

In the illustrated example, the vertical screen that starts from the bottom of the wall, faces the main street. Therefore a high level of privacy is needed for the spaces behind this portion of the screen. The top portion of the screen acts as the handrail of the balcony and needs less privacy. To design each of these screens separately, the wall is divided by two and each portion becomes a new input for the Grasshopper workflow.

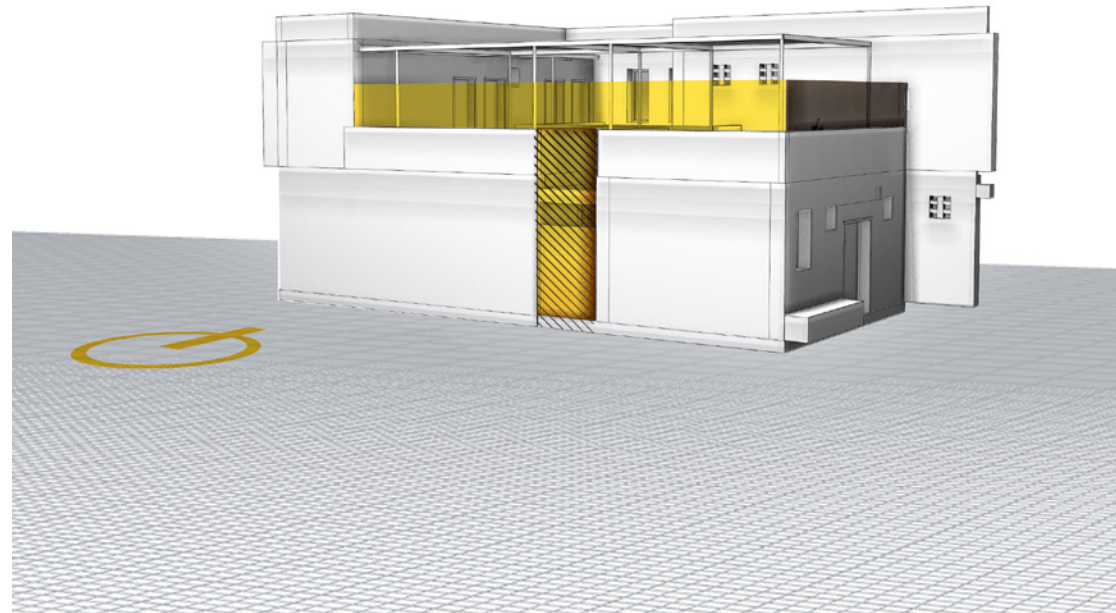
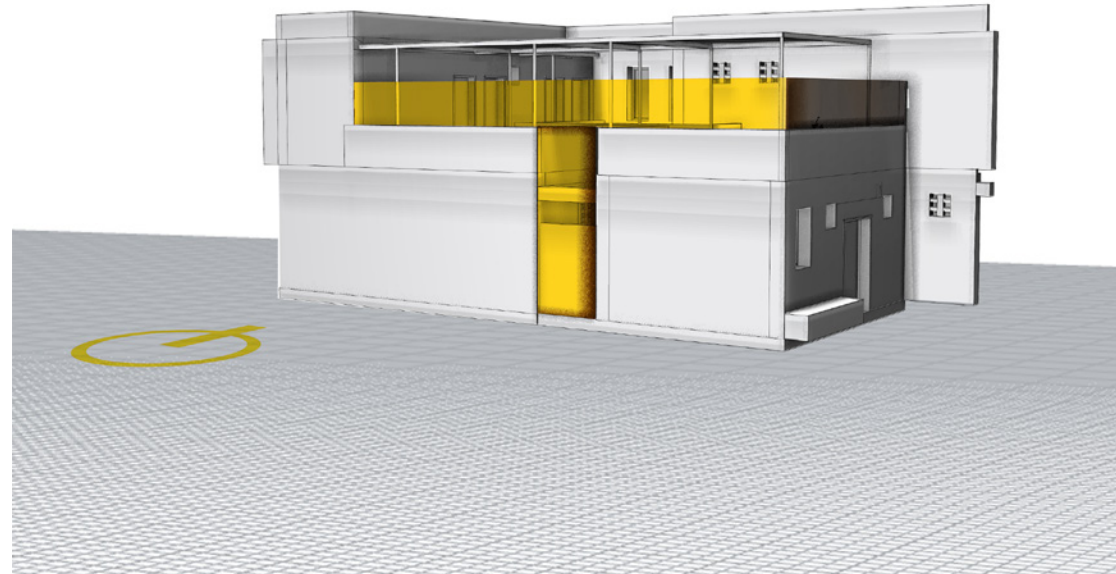

Figure 46: South-facing screens

To design the bottom portion of the screen wall, the dimensions of that portion of the wall that includes that screen, brick dimensions and mortar thickness should be defined by the user. Based on these input the Grasshopper component creates the 3D representation of the base wall for the screen.

The 3D representation of the wall in the Rhino workspace lets the user get a general feeling about the brick wall with Flemish bonding in a fast and easy way. This is a good step for studying the brick properties. The designer can try using different sizes of bricks if the project has access to more than one brick type.

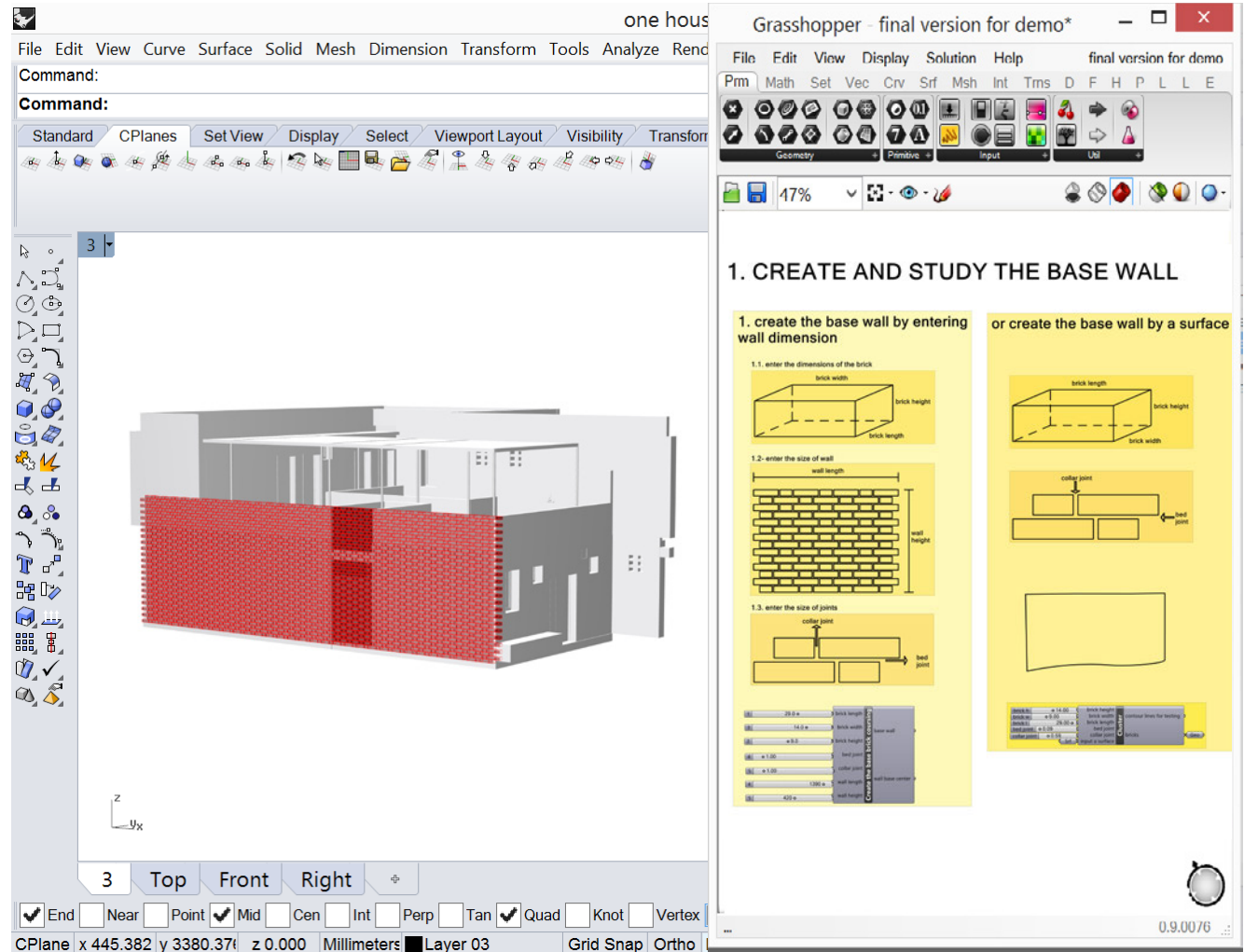

Figure 47: Create the flat wall

6.1.2. STEP TWO: PICK A COLOR

In order to better visualize the bricks, the workflow lets the users choose a specific color for them. This component includes pictures of bricks with different colors and their names. This can help the user to pick the right color for the brick and also know the exact color name to look for in order to find that particular brick color in the real world.

As shown in the images, after picking the color, the 3D visualization of the wall is formed with that color in the Rhino environment. All these steps are interactive and at any point during the process the user can change the color or the size of the bricks.

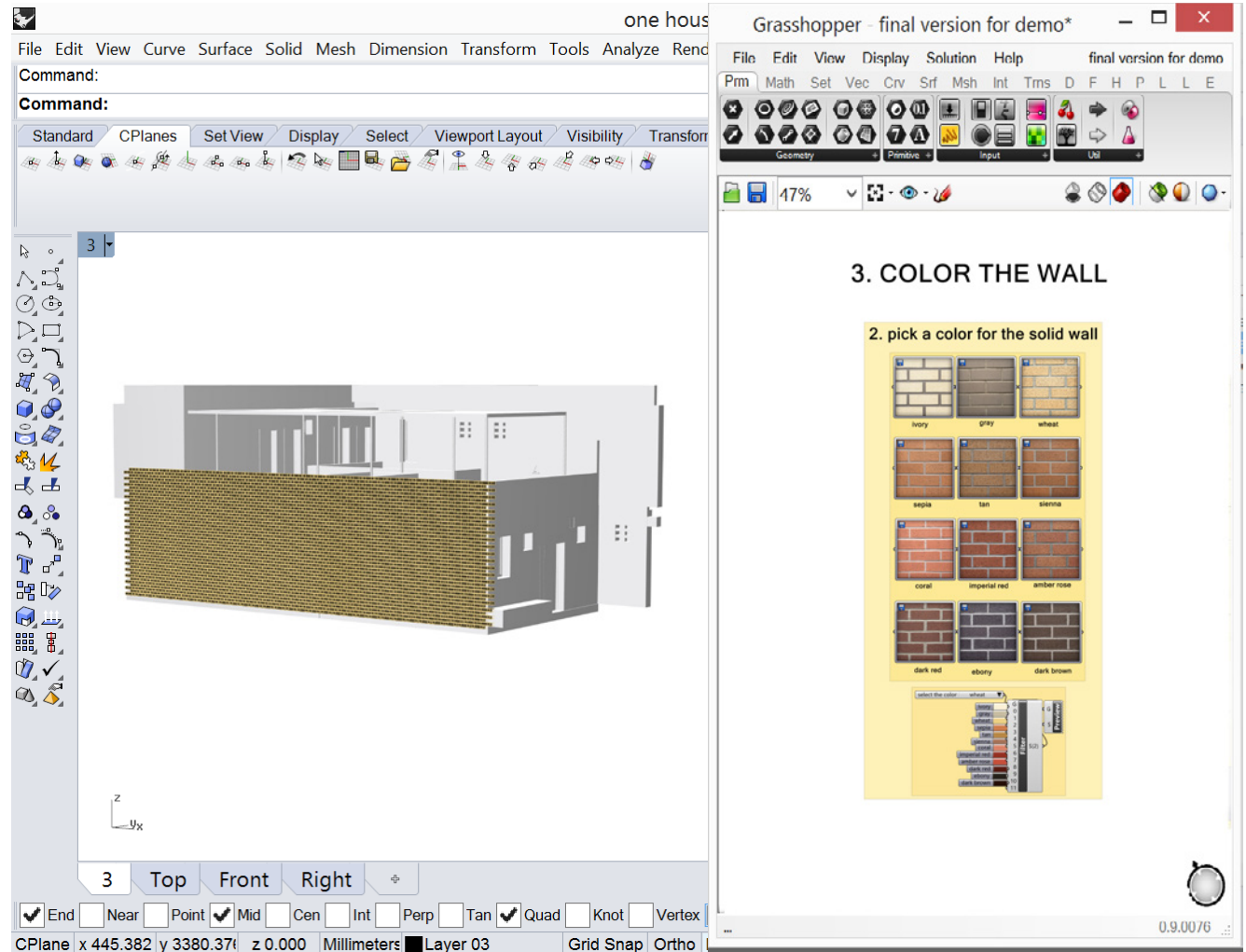

Figure 48: Pick a color for bricks

6.1.3. STEP THREE: SIZE THE SCREEN

As shown in the diagram, by inputting the length of the solid wall before the screen starts and the length of the screen, the screen portion of the wall disappears from the solid wall.

There is also the option for inputting the height of the solid wall below the screen and the full height of the screen in case the screen doesn't occur in the full height of the wall.

This step can help in making design decisions in terms of the placement of the screen within the wall. By changing the height and width of the solid portions of the wall and the screen, the designer can interactively decide what ratio of screen versus solid wall is appropriate for the design.

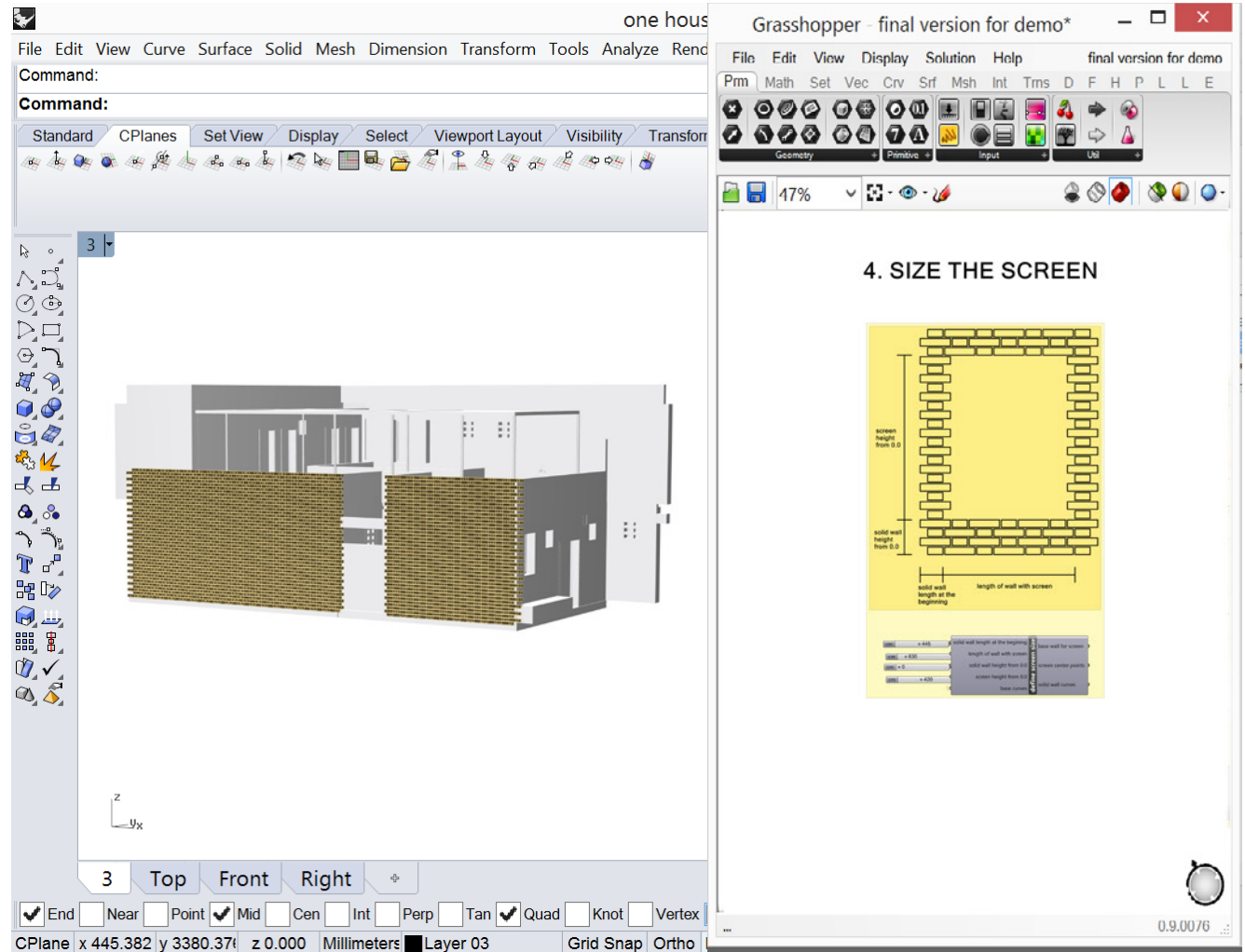

Figure 49: Size the screen

6.1.4. STEP FOUR: STUDY THE SUN

The next component of Grasshopper workflow lets the users see the sun position in the Rhino model according to the geographical location and time of the year. This cluster is made using Ladybug, an open-source environmental plug-in for Rhino/Grasshopper.

The inputs for this cluster includes the North vector, the time zone, the latitude, the longitude and the time of the year. The first step is to define a vector in Rhino environment showing the direction of north. The vector can be defined by clicking anywhere in the Rhino environment as the start point of the vector and clicking again in the direction of north. After inputting the geometry of the wall to the component and other required data, the sun path for that specific location and time is drawn.

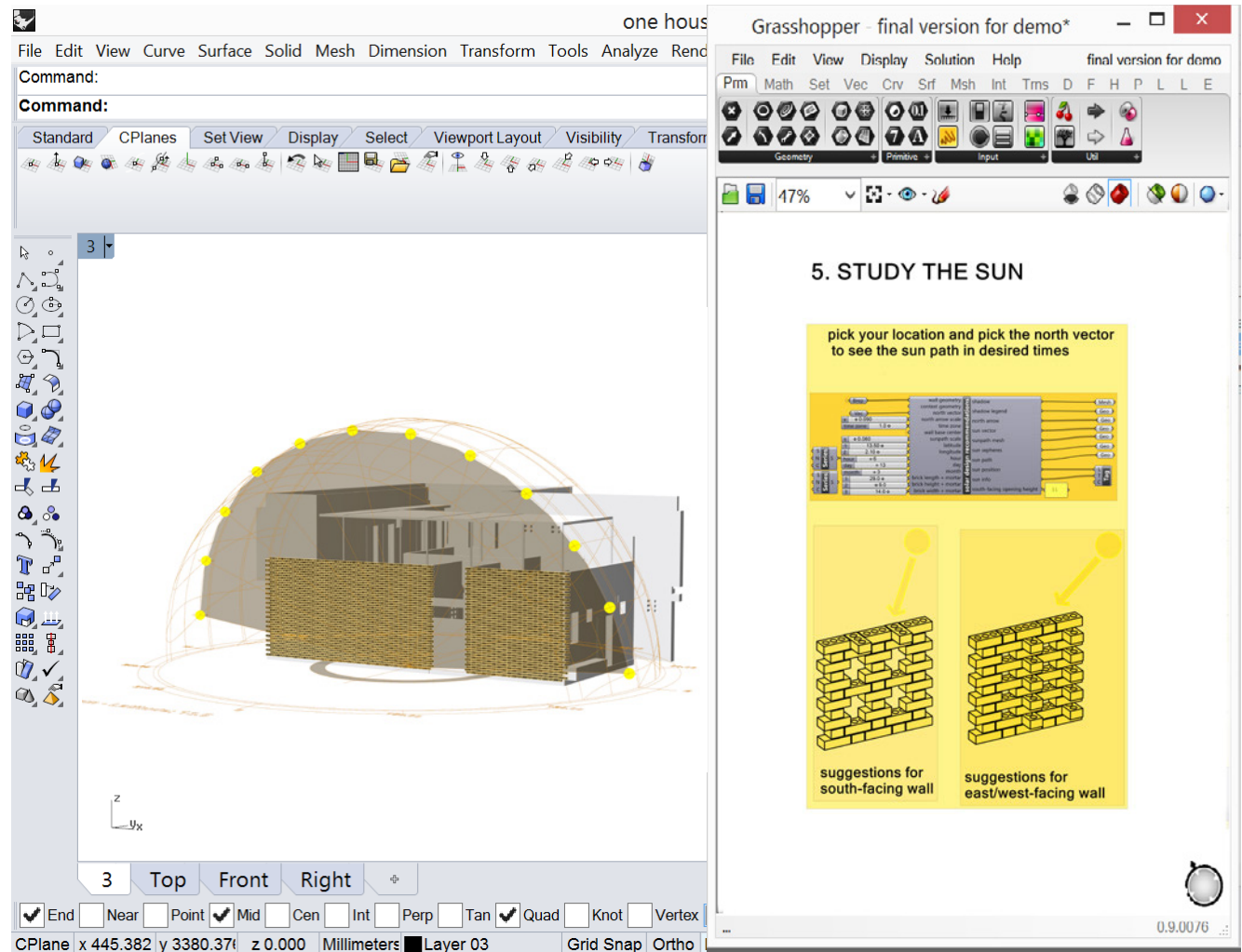

Figure 50: Pick the location and time of the year

By picking different times of the year the sun location changes. Also by inputting a series of numbers for hours, days and months, multiple sun path diagrams are displayed. This can help the user understand how to design the screen to control natural light throughout the year.

As part of this step, a few diagrams show suggestions for creating openings that can work well for different orientations. For a south-facing wall, the height of the opening can be defined according to the sun altitude and the width of the brick (wall depth) (figure 52). The suggested opening height for a south-facing wall is one of the outputs of this component. Based on this number the user can decide about the number of bricks he should remove to reach the desired opening height.

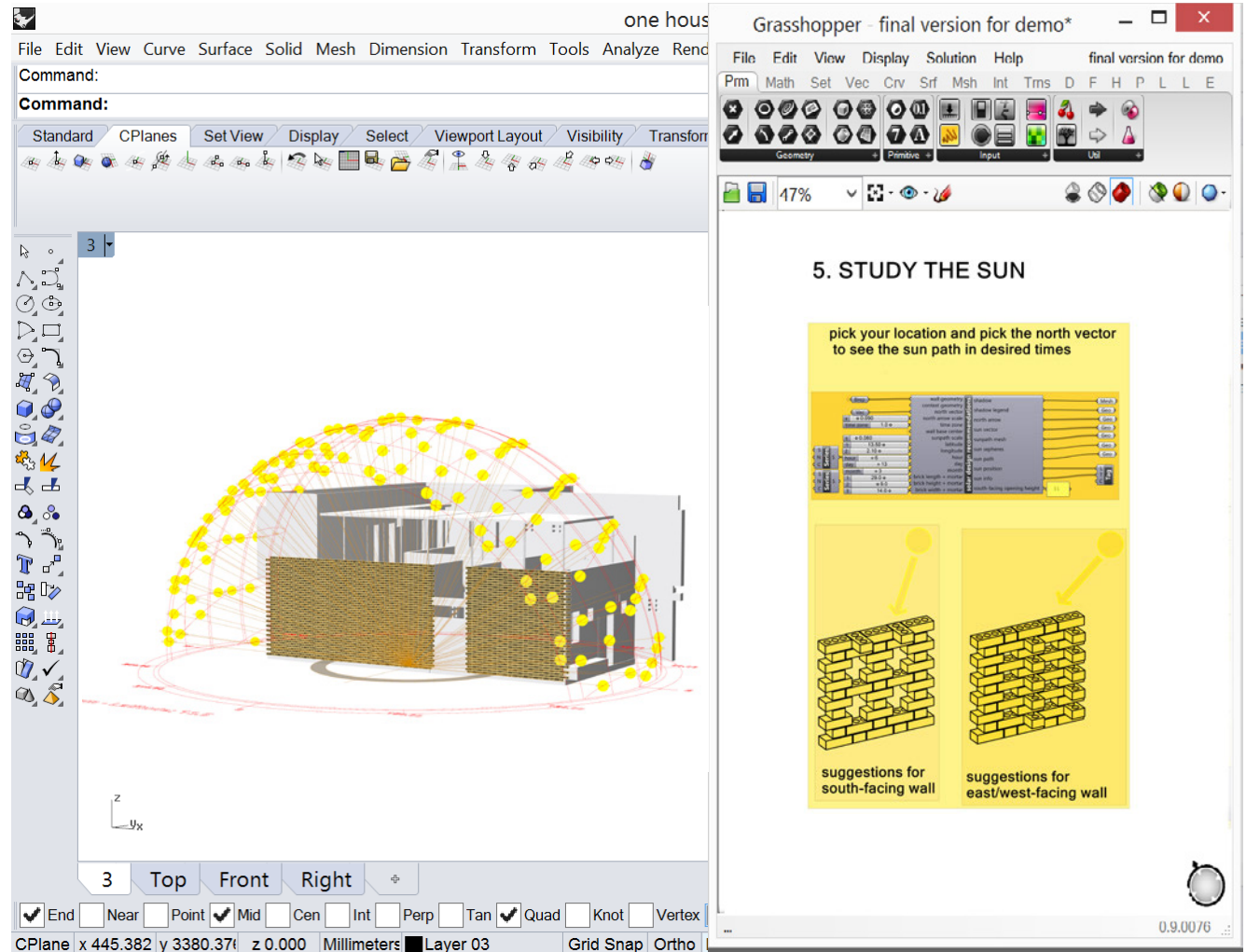

Figure 51: Study the sun

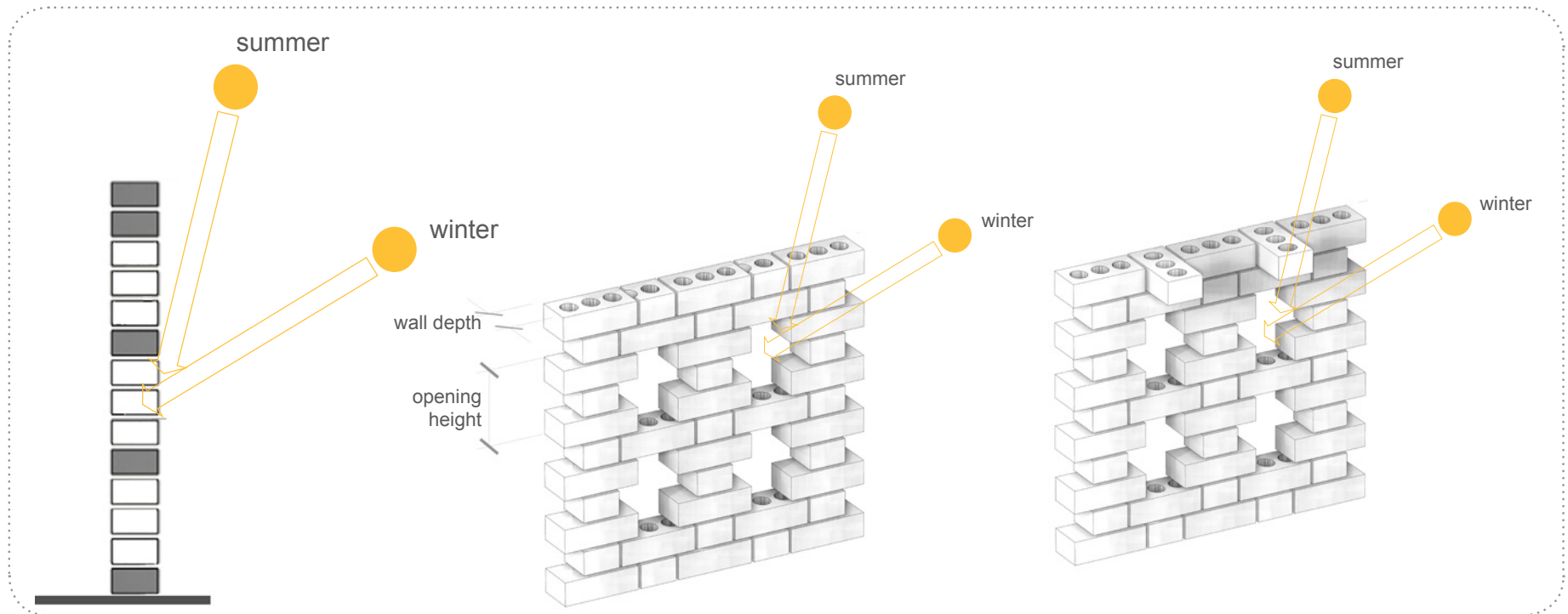

Figure 52: Suggestions for south-facing wall

Another option for south-facing walls, is to extend out the brick that is above the part of the opening with a larger opening height. This overhang will allow for creation of larger openings and help with blocking the sun in summer and letting it in winter (figure 52).

For the east/west-facing walls, by extending the bricks out on the sides of the openings, a vertical fin is created which can help in controlling natural light (figure 53). By looking at the sun-path while designing the screen and seeing the suggestions for better controlling the sun, the user can create a screen that responds well to project's requirements, the environment and seasonal changes.

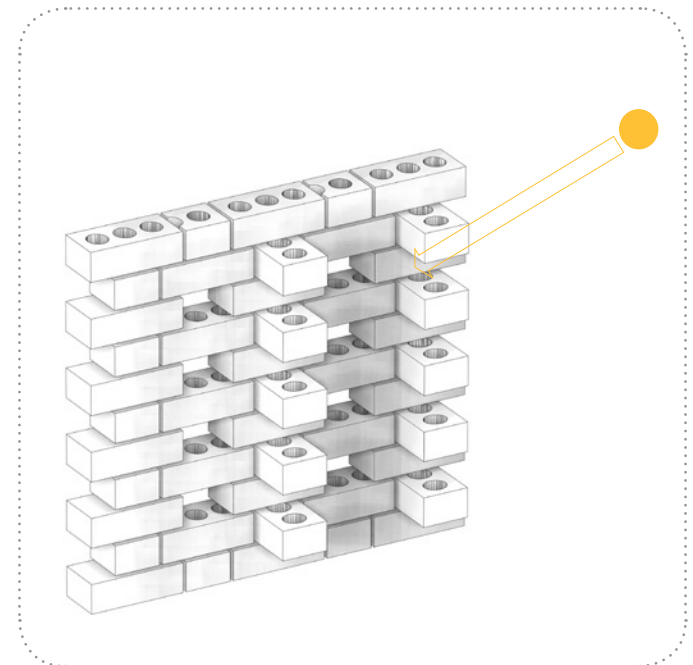

Figure 53: Suggestions for east/west facing wall

6.1.5. STEP FIVE: PATTERN

Pattern creation: Brick options

The next step of the design process allows the users to design various patterns within the brick screen. For each brick there are six options to choose from. By default the bricks are drawn as a stretcher or as half-bat depending on where they are positioned within the bonding. The user can change this default positioning by making a stretcher brick a half-bat or vice versa if the adjacent bricks allow for that. The other options include removing the brick to create an opening, extending the brick out or in, depending on on where the interior or exterior space is, and extending the bricks both ways. The main rule of thumb for the designer to remember while picking an option for the brick is that the span of the opening shouldn't be larger than the brick length (figure 54).

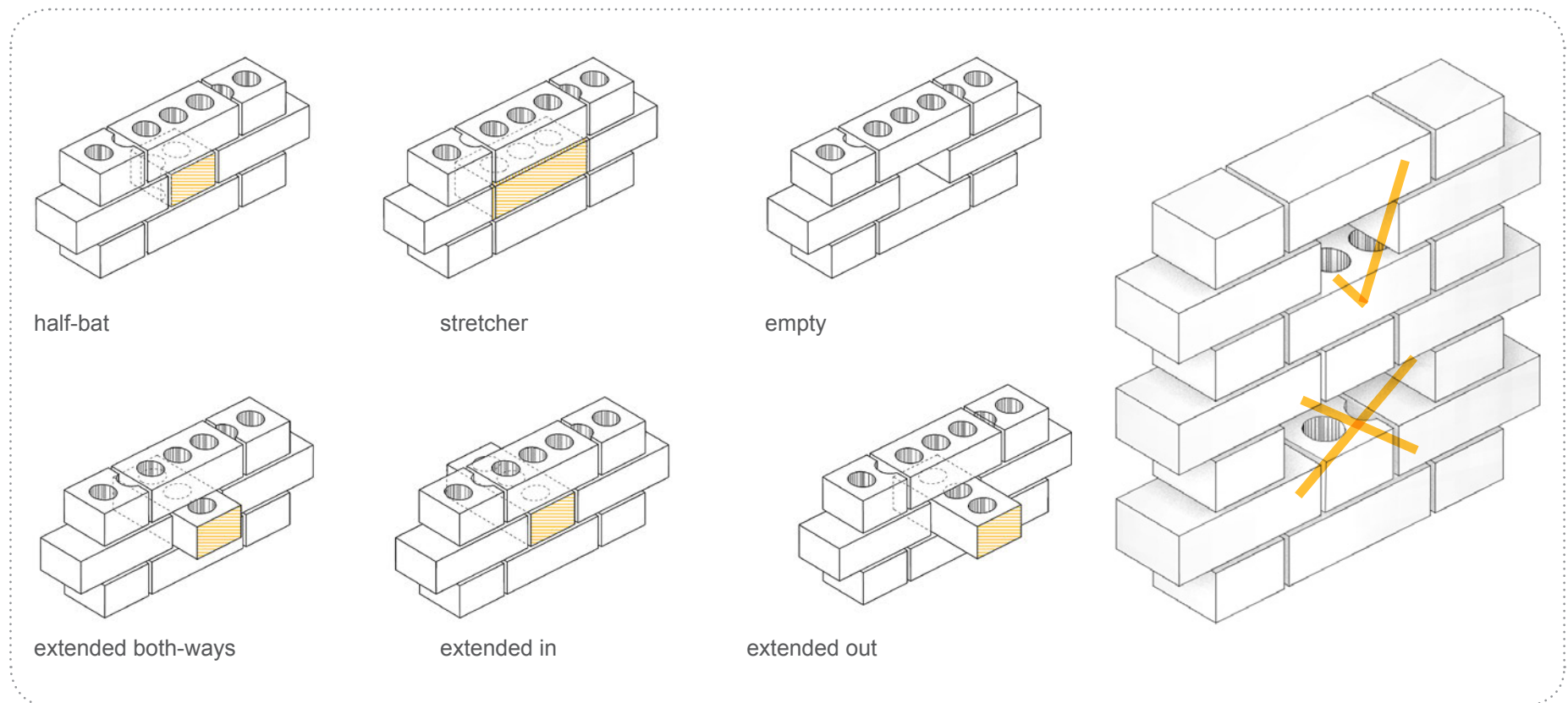

Figure 54: Brick options

Pattern creation: Opening shape

Based on the suggestion for opening span, options to choose from for each brick and opening height, various forms of openings can be created. Figure 55 shows a number of possible opening shapes based on these variables. The number of choices are increased by including options for extending the bricks. Besides the possible options for creating each opening, there are various ways for putting these opening next to each other in a screen. Figure 56 shows the possibilities for creating a brick screen with two or three openings, each with the height of two brick courses. Instead of automating the process of pattern creation, this thesis allows the users to choose any form and size of the opening by having the control over each brick. That said, repetition of a pattern within a screen is proper for ease of construction and for interior and exterior visual comfort. Also the screen wall needs a reinforcement system in order to be self-supporting and the grid of the reinforcement can be a guide for creating repeating patterns.



Figure 55: Brick opening options

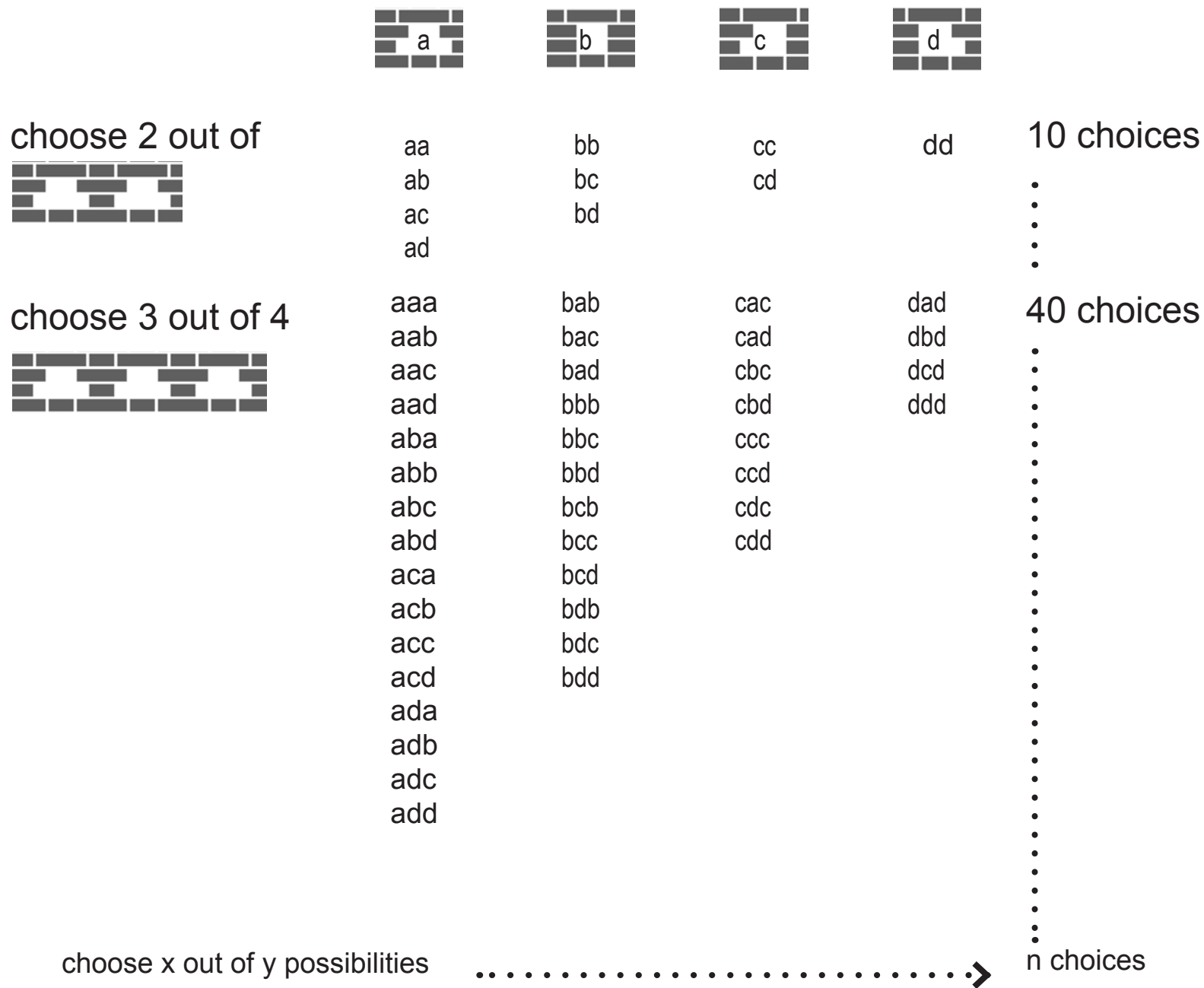
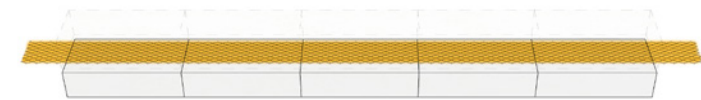
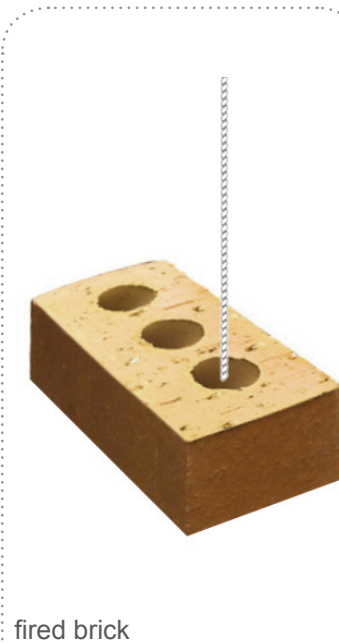

Figure 56: Number of options for creating patterns

Pattern creation: Reinforcement grid

Vertical reinforcement can be added to the system by putting Reinforcement bars in the brick holes and tying the bricks together using the bars (figure 57). Different types of horizontal reinforcement can be added to the bed joints within the brick courses. Some of the common horizontal reinforcements include Expanded Metal Mesh and Welded Ladder type as seen in figure 58. Another option is to use Reinforcement bars in the horizontal bed joints. The bars can be bent to create the desired form, matching the wall curvature. A suggested grid of reinforcement can be created using the vertical and horizontal reinforcement elements. The number of brick in a unit of the grid can vary depending on the structural requirement in each location and factors like the type of brick, the type of soil and seismic requirements.

In this thesis the grid is designed using a rule of thumb, assuming to have vertical reinforcement in every seven bricks in a row and horizontal reinforcement in every ten courses of bricks (figure 59). The required reinforcement can be less if the wall form is not flat because of the improved lateral support. Also the grid can be irregular to let the user have more option for designing patterns (figure 60).



Expanded Metal Mesh



Welded ladder type Bed Joint

Figure 57: Vertical reinforcement

Figure 58: Horizontal reinforcement

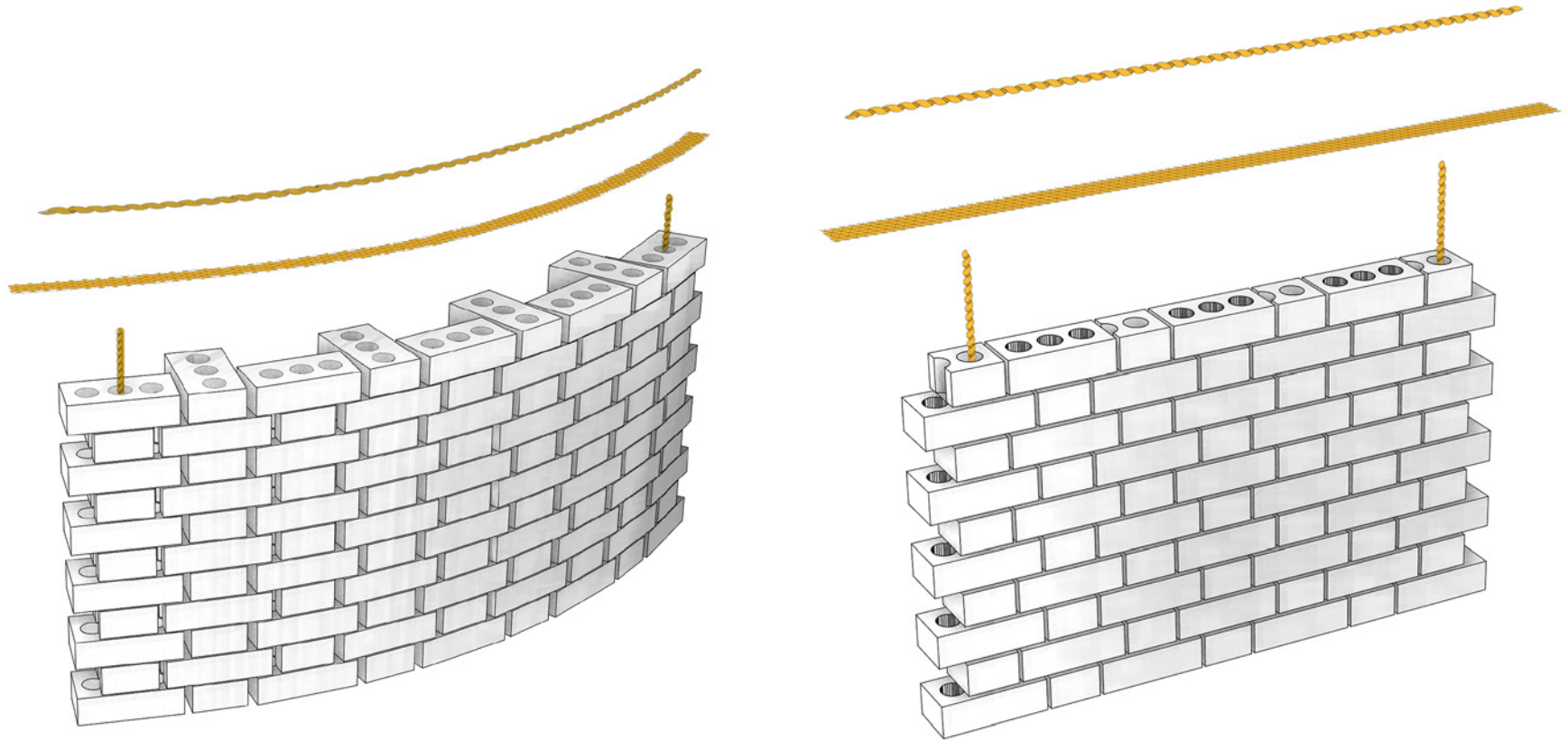

Figure 59: Suggested reinforcement grid, 10 courses and 7 columns of brick

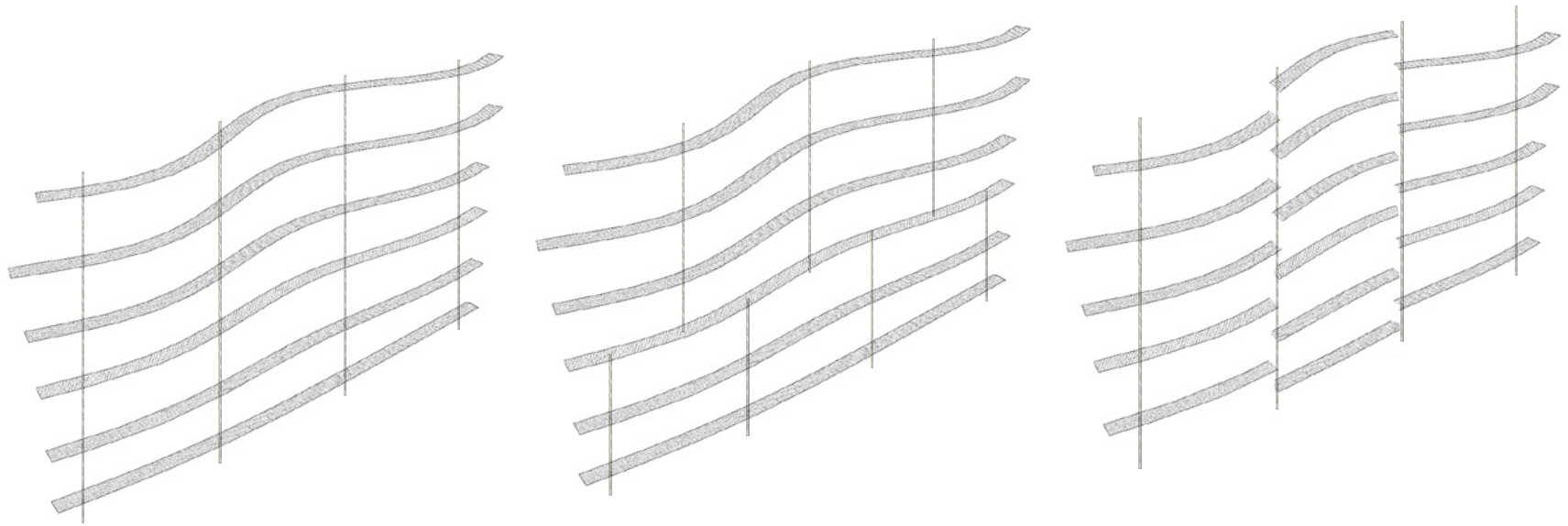

Figure 60: Reinforcement grid options

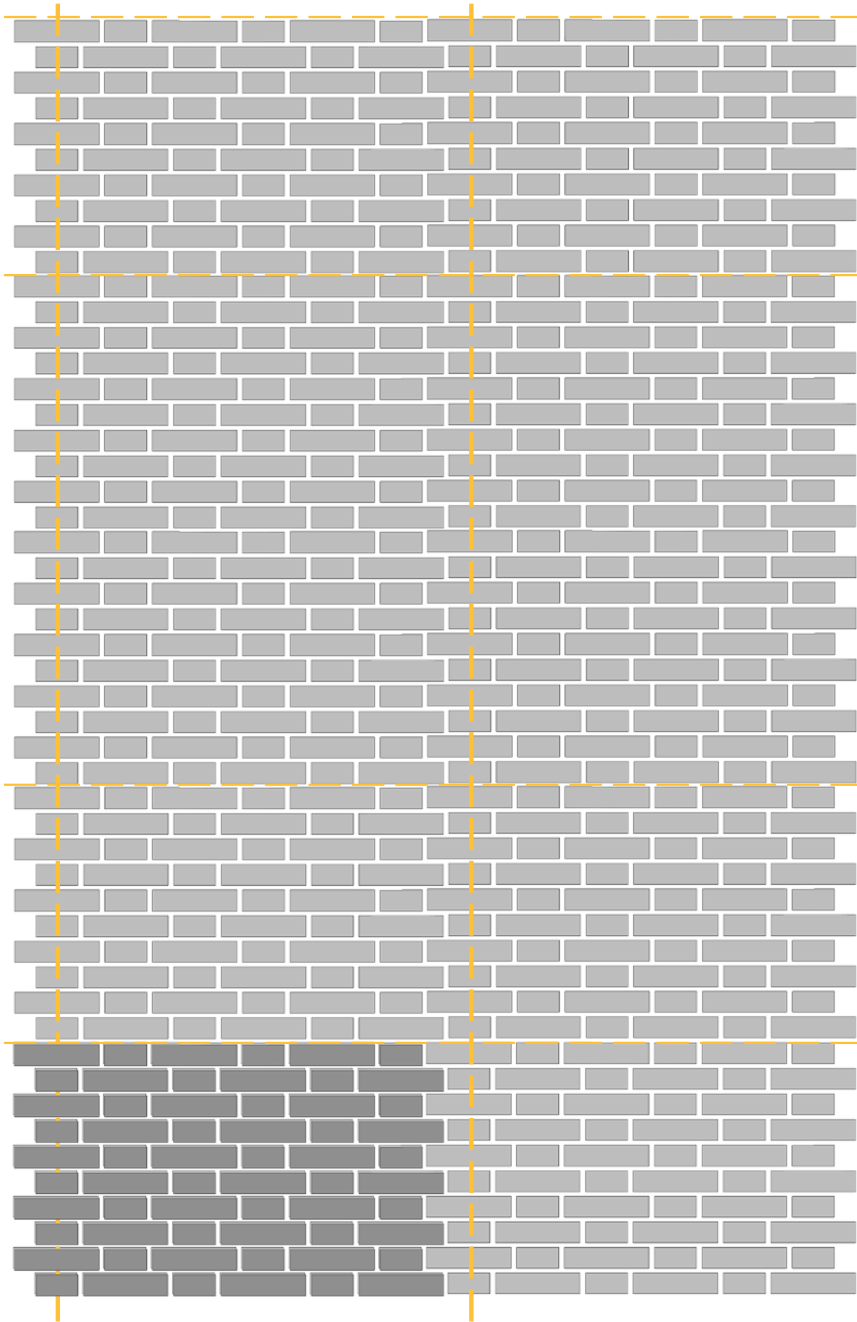

Figure 61: Brick switch pattern

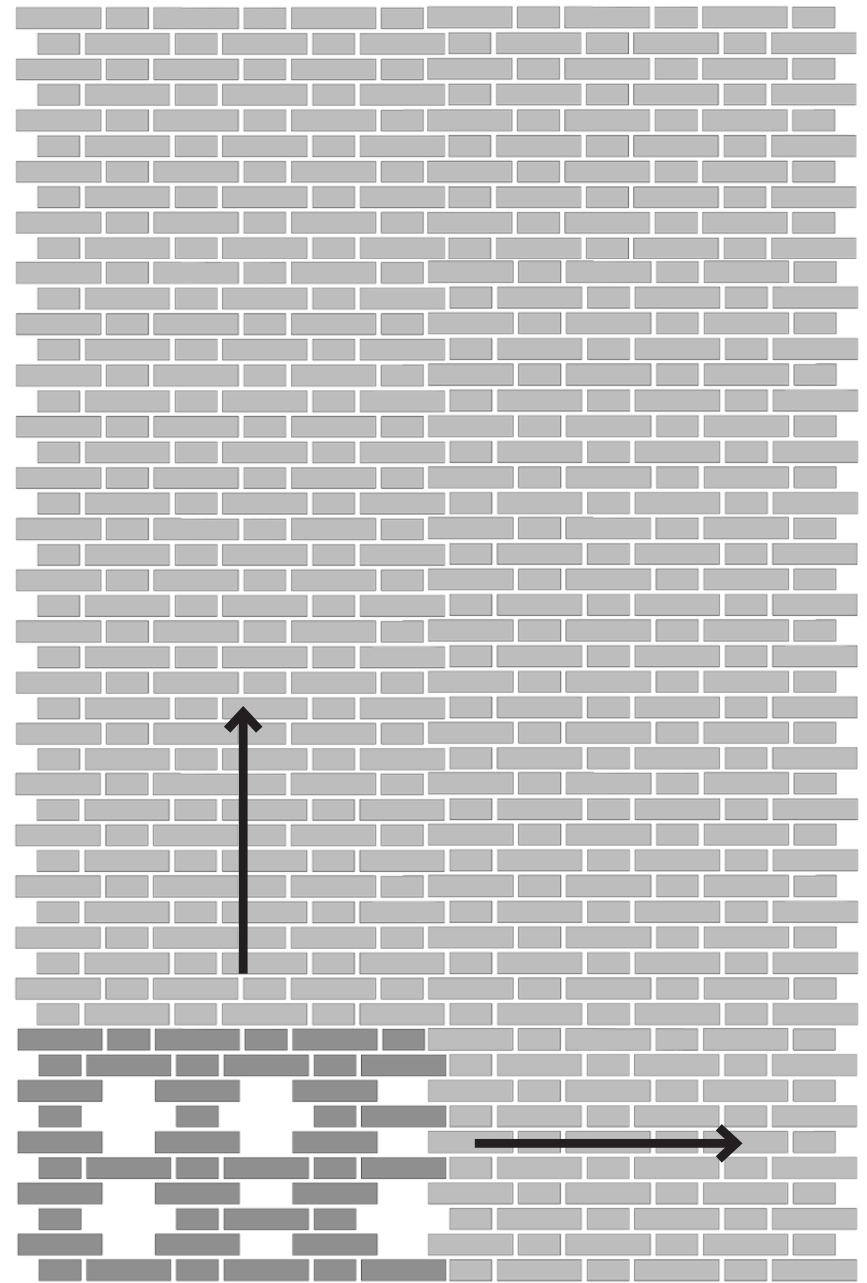

Figure 62: Brick switch pattern

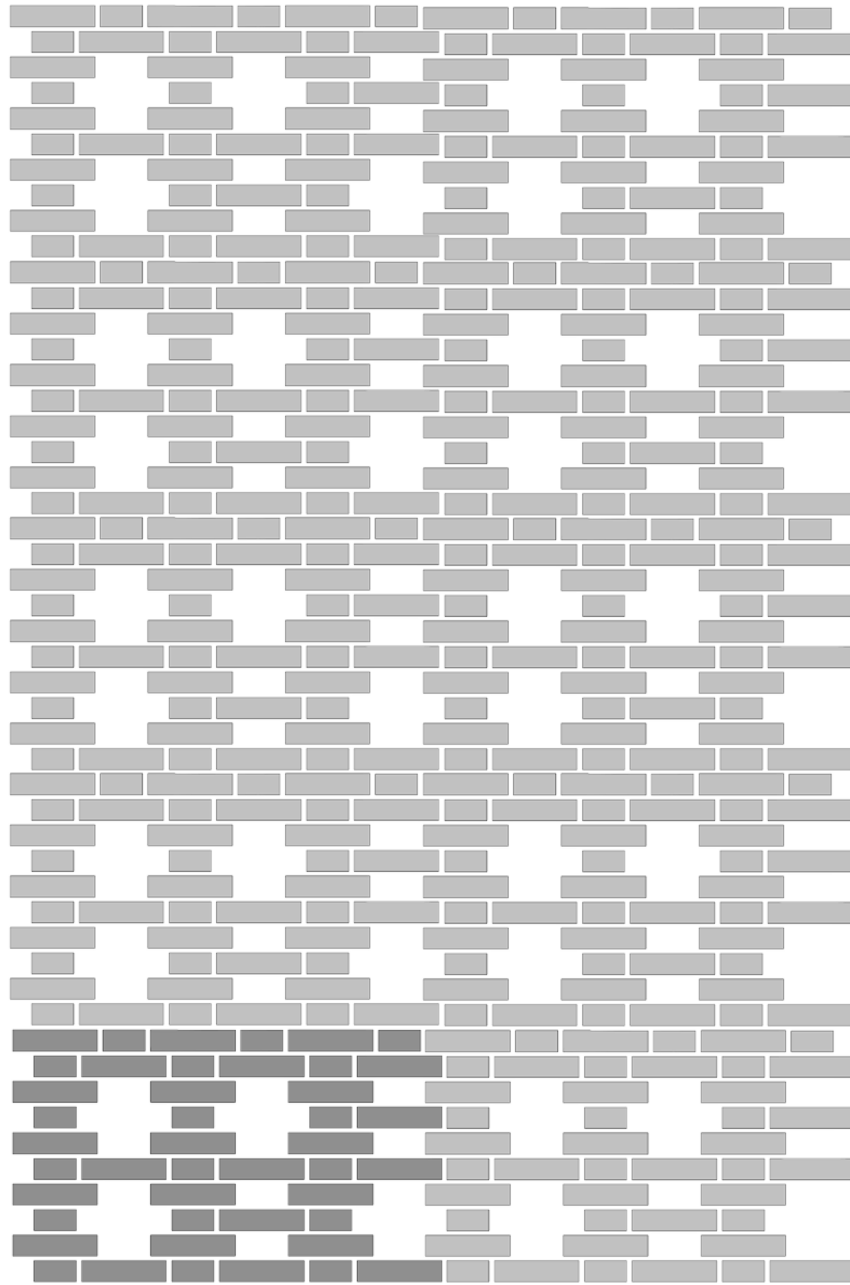

Figure 63: Brick swatch pattern

Pattern creation: Pattern switch

Based on the suggested reinforcement grid, the user can start designing the brick screen. By designing the pattern within a unit of the grid, the same pattern gets repeated in other units of the grid. In this methodology one unit of the structural grid acts as a swatch within which the user have control over the placement of each individual brick.

As seen in figures 61, 62 and 63, the swatch pattern is designed first and then the same pattern is applied to the rest of the grid. If the user prefers to have more than one swatch pattern, the screen can be divided to sections and each section can be designed as a separate brick screen next to the rest of the screens. Figures 64 to 68, show the process of designing the screens for the Niamey housing project.

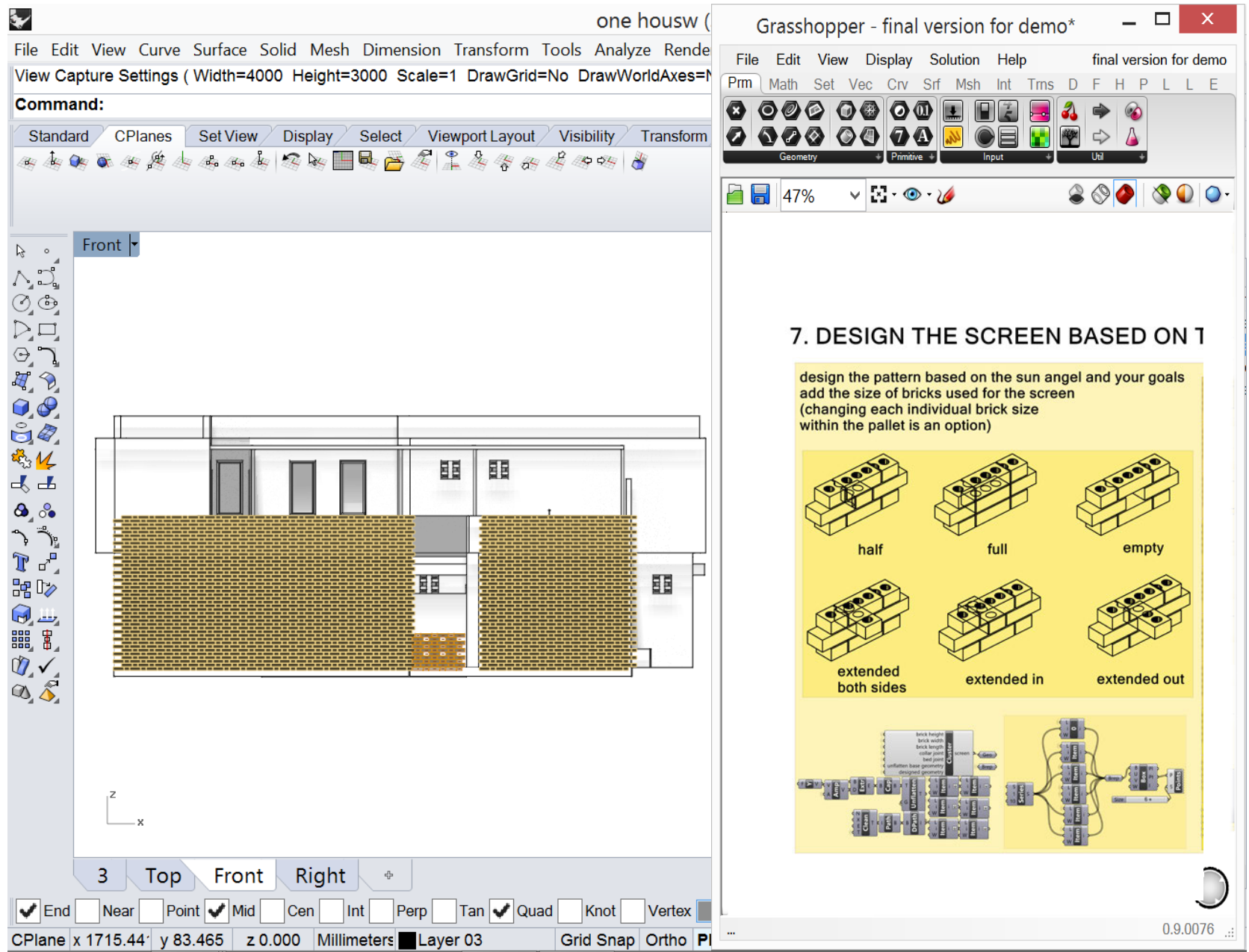

Figure 64: Designing the bottom portion of the screen

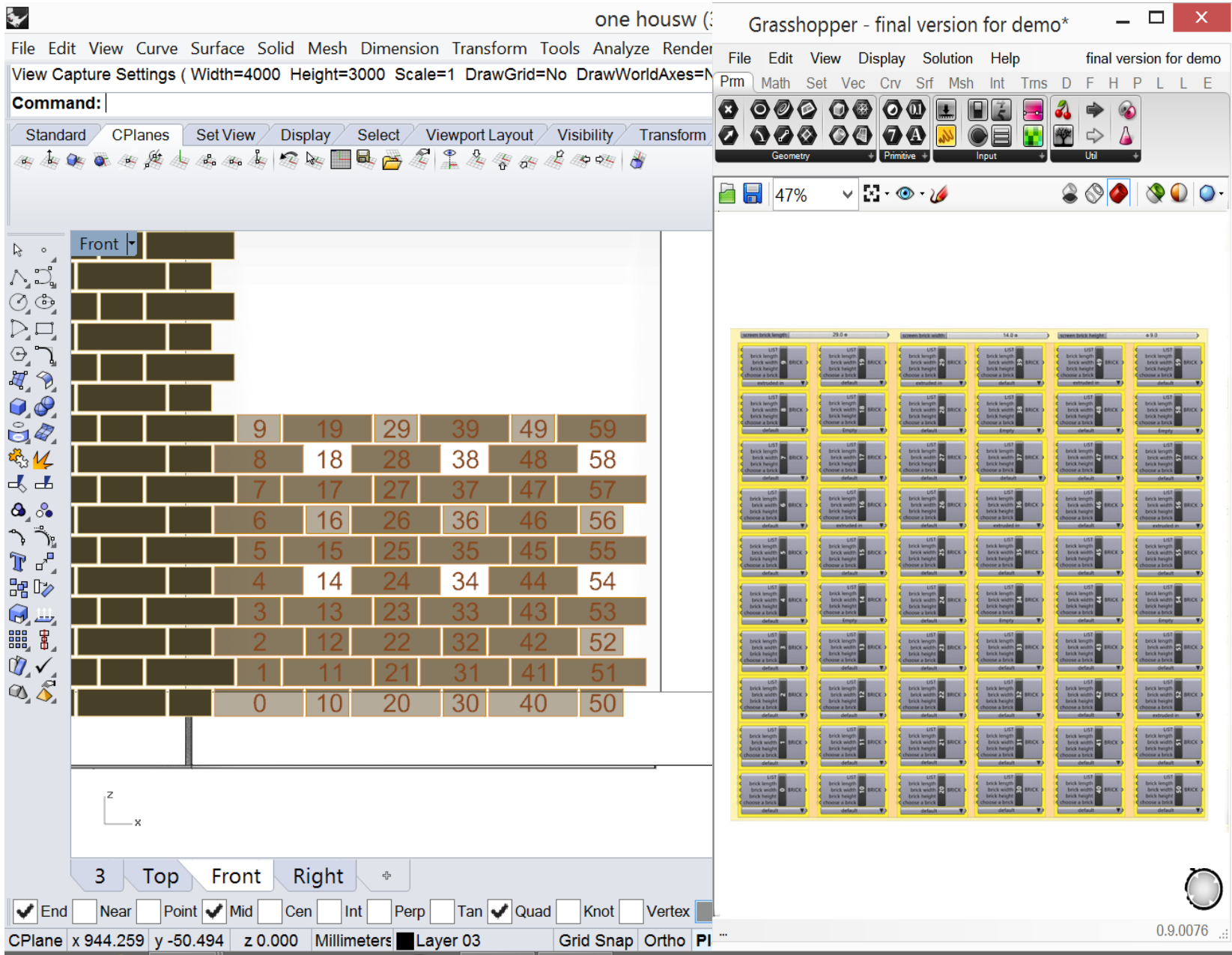

Figure 65: The pattern switch

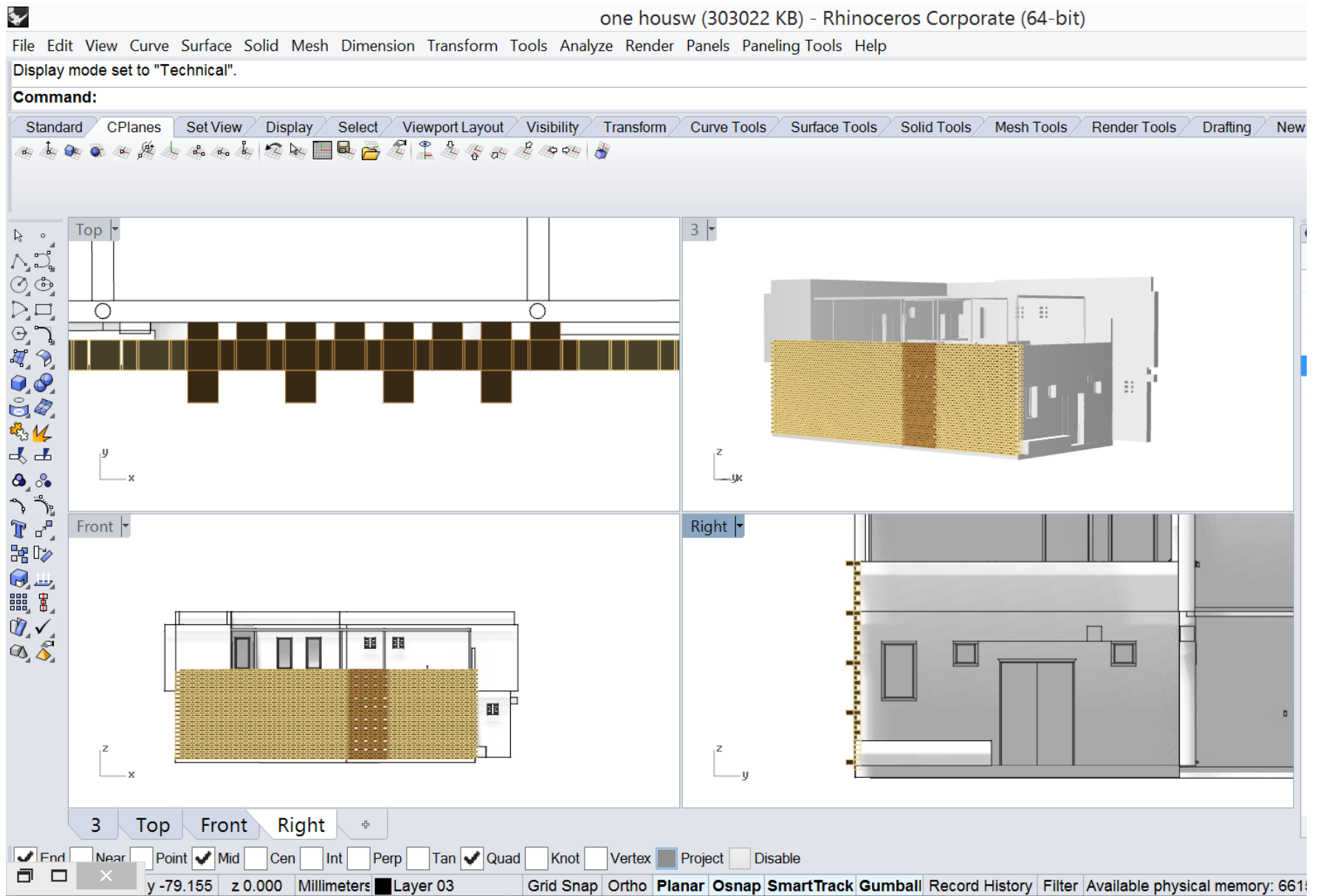

Figure 66: The bottom portion of the screen

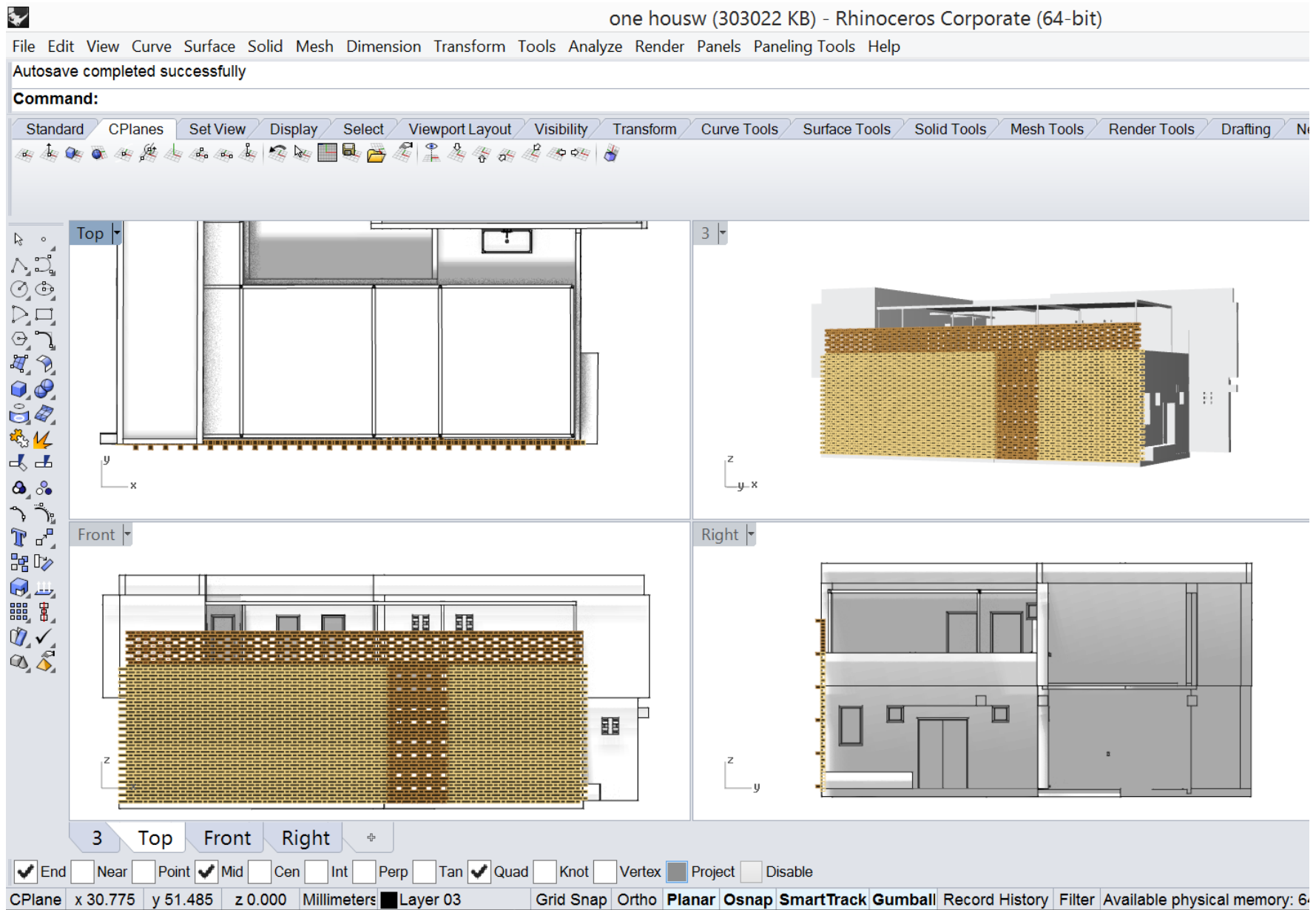

Figure 67: The top and bottom portion of the screen



Figure 68: Fully designed screens

6.2: DNA-BRICK ASSEMBLY: THE CONSTRUCTION PROCESS

After designing a brick screen wall, the drawn patterns should be used to build the wall. Based on the design goals and using the computational design tools, a wall with many different patterns and forms can be drawn. The main challenge is how to communicate the result of the design process with a mason and how to make the complexities of form and pattern understandable and constructible with brick and mortar (figure 69).

The end results of the design workflow should include diagrams that clearly show the layout of the masonry system and should be easy to understand by average design/building professionals. An example for such diagrams is the kit that is developed for Brick Pattern House in Tehran, Iran (figure 70). This building is a residential apartment, located in a poor neighborhood, challenged with a low budget. The construction procedure of creating this screen system is similar to putting together a large puzzle with each package having a code to identify the location and orientation of the bricks. The kit provides instructions on A4 papers with a chart numbering the items creating simple diagrams for the mason²². The workman first opens the box no.1 and put the bricks in to the framework starting from number one and ending to no. 23.

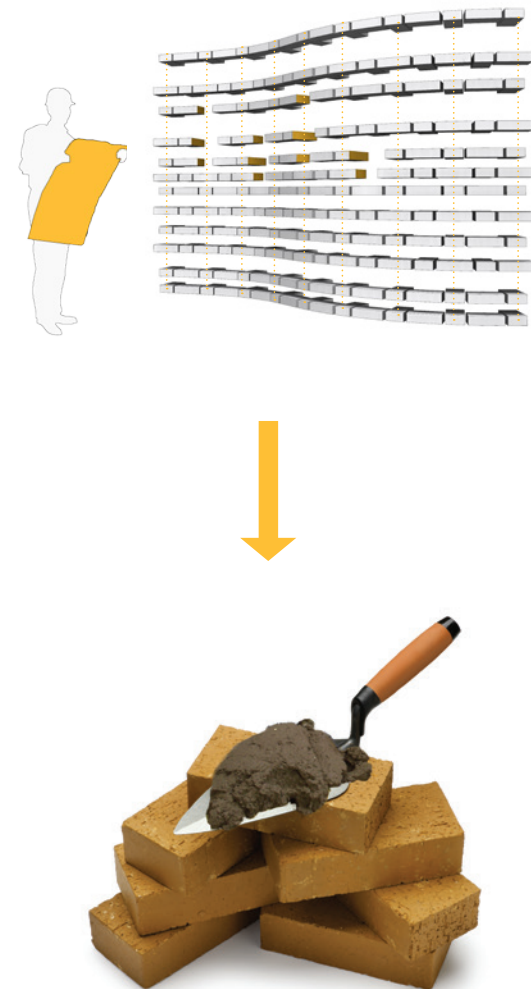

Figure 69: Guiding the mason

²² Brick Pattern House by Alireza Mashhadimirza, accessed Nov10, 2013, <http://www.design-boom.com/readers/brick-pattern-house-by-alireza-mashhadimirza/>



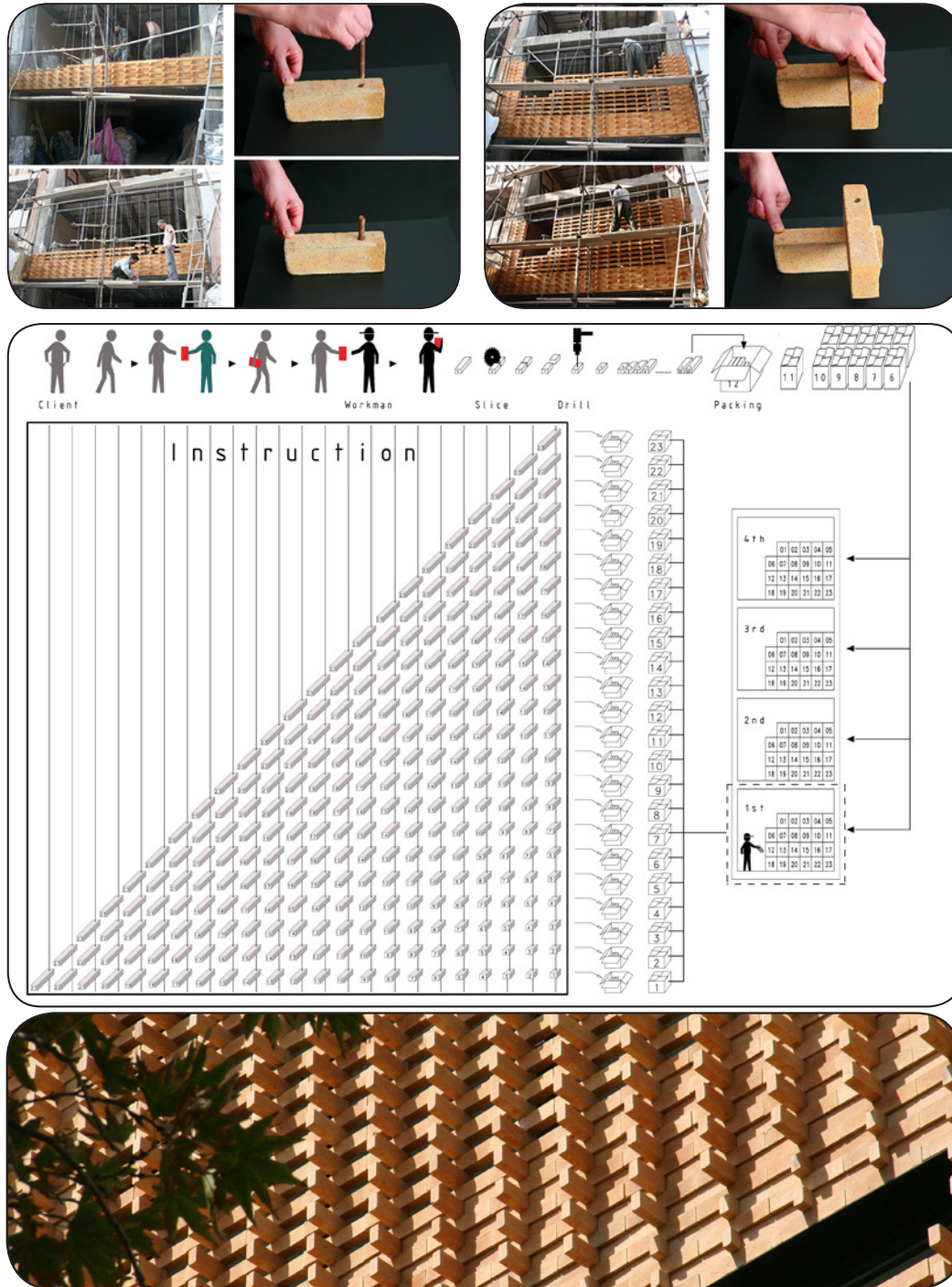
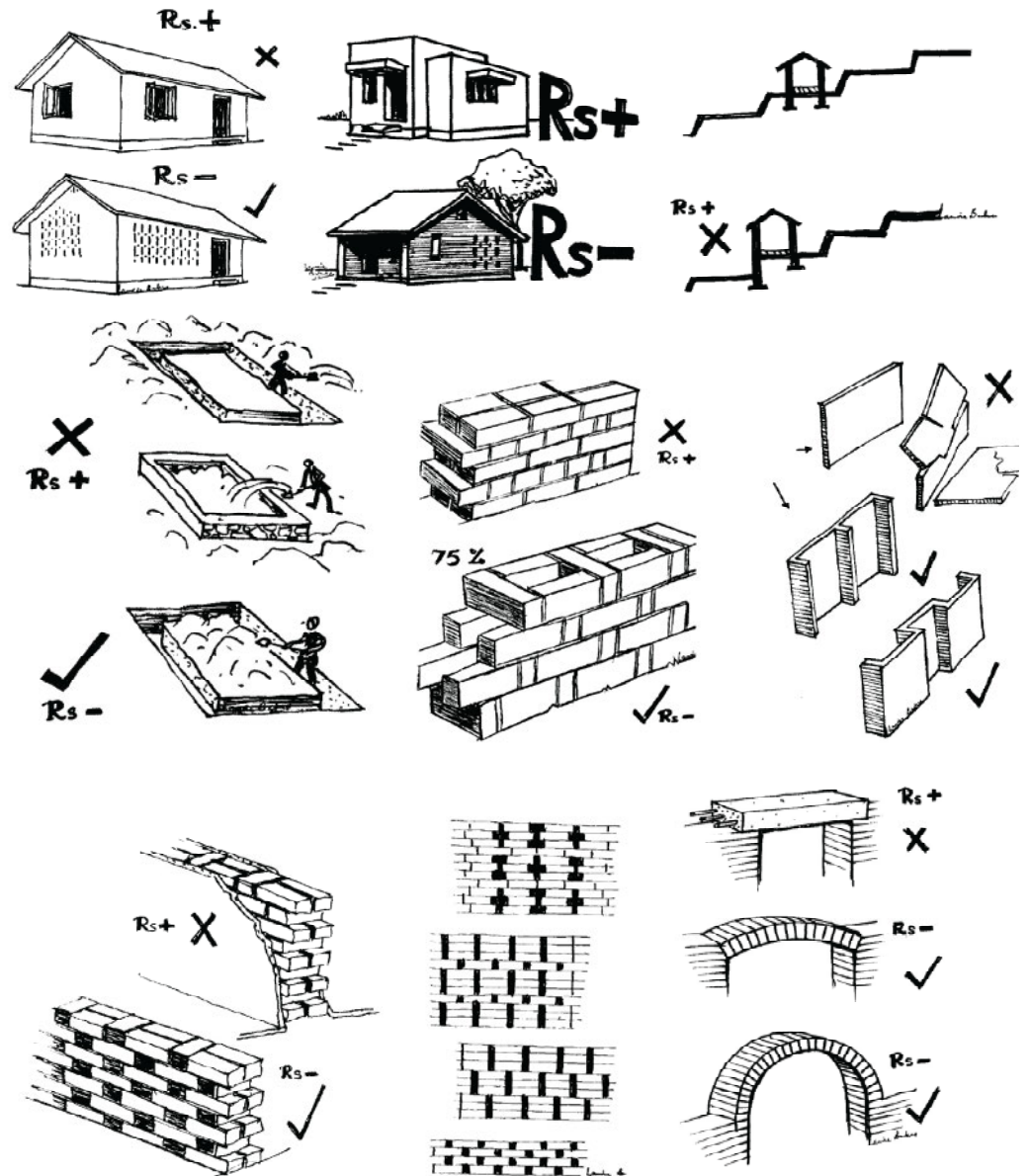

Figure 70: The Brick Pattern House@<http://www.designboom.com/readers/brick-pattern-house-by-alireza-mashhadimirza/>

Another helpful part for the construction kit is a set of simple sketches that can show the designer/builder/client/ mason how to build the wall step by step. Figure 71 shows sketches that were developed by British-born Indian architect Lauri Baker, providing very simple and useful explanatory figures about constructing a low-cost brick house²³. Simplicity of these sketches made them understandable by unexperienced masons, encourage those with little or nor experience in masonry to build or repair their brick houses.

Lauri Baker's diagrams are applicable to various projects. Similar sketches can be used to visually tell masons how to go through the construction process of a wall system.



23 Bhatia, Gautam, *Laurie Baker, life, work, writings* (Viking 1991), p15.

Figure 71: Brick construction sketches by Lauri Baker@*Laurie Baker, life, work, writings*, p15.

6.2.1: DNA GUIDES

This thesis proposes to use simple paper guides, called DNA guides that are drawn with Grasshopper/Rhino. The guides tell the mason how to work with the bricks. The DNA guide includes all the information that is needed for a mason to know where to put each brick, where to not put a brick to create an opening and how to turn the bricks in a row to create a curved form. One guide is drawn for each unique course of brick screen and the same guide can be used to build similar courses. If the wall has double curvature, then each course will have a specific guide drawn for that course of bricks.

The DNA guide should be used with simple diagrams that demonstrate the construction process of this system. Also drawings of the screen system, including perspectives and elevations can visually help the mason understand the project and build it easier. To demonstrate this process, I will use an example of a double-curved wall that is designed with the grasshopper definition and go through the construction steps using graphics and diagrams. I am using a curved wall to demonstrate this process because the building process of a flat wall is simpler. The first step after designing the wall and its openings, is to customize it based on the project's intent. In the example, I assumed the wall will have a big opening and removed certain bricks from the designed geometry (figure 72 and 73).

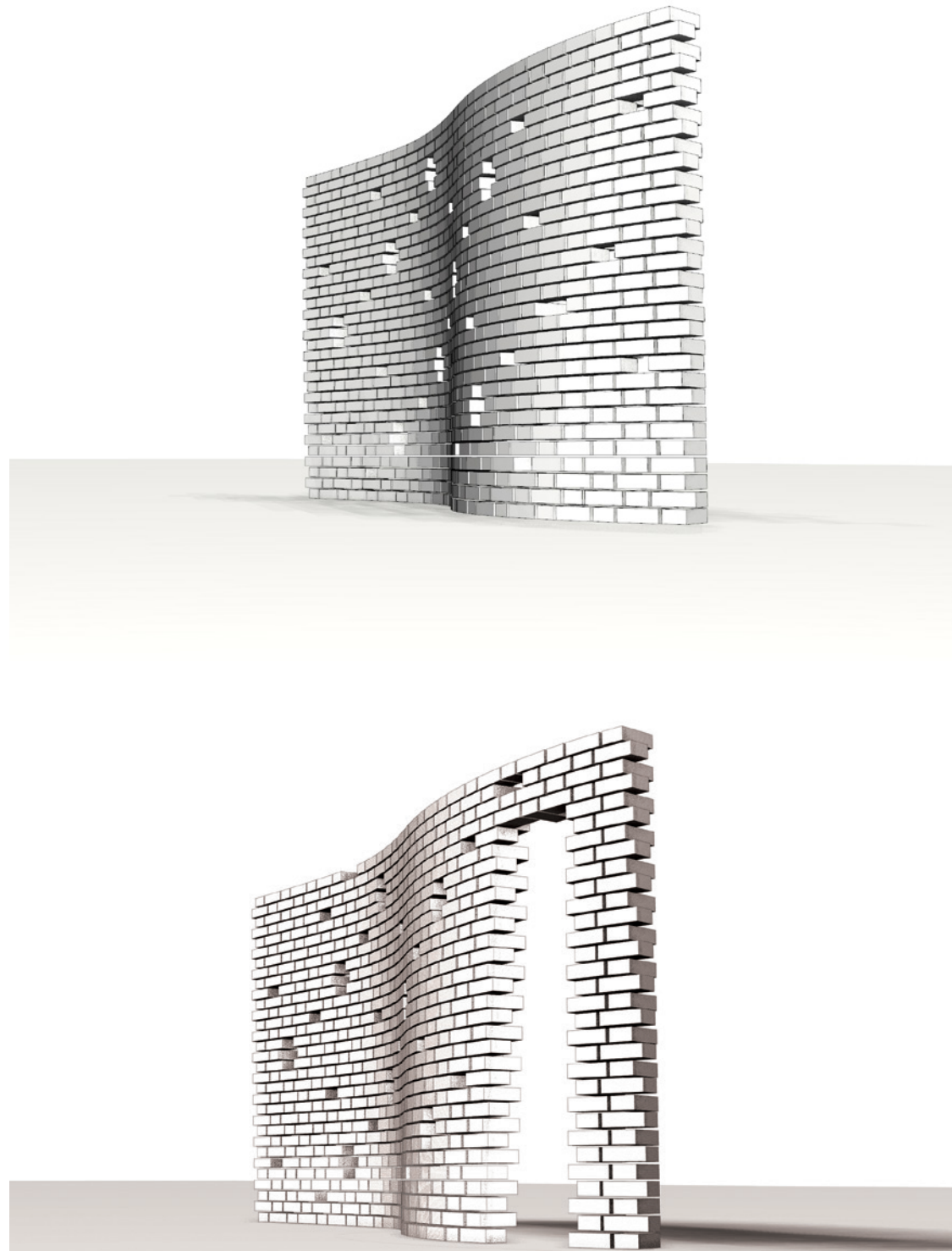

Figure 72 and 73: Designing and customizing a brick screen

After customizing the wall, the geometry can be inserted to the Rhino/Grasshopper guide-making component and as seen in figure 74 the DNA guides are drawn. Since this wall is curved both vertically and horizontally, there is one guide for each level. The base level (guide 0) only shows the bricks of that level. Starting from level one up, each guide shows the bricks in that course and also the bricks in the course below that course. This will visually help the mason to know where to put each brick in relation to the bricks in the course below. The centerline of the wall shown in orange in figure 75 and 76 stays identical in each guide and can help the mason as a reference to find where to start and where to finish each course. It can also be a visual reference relating to the string guides that masons use on site to keep the wall leveled.

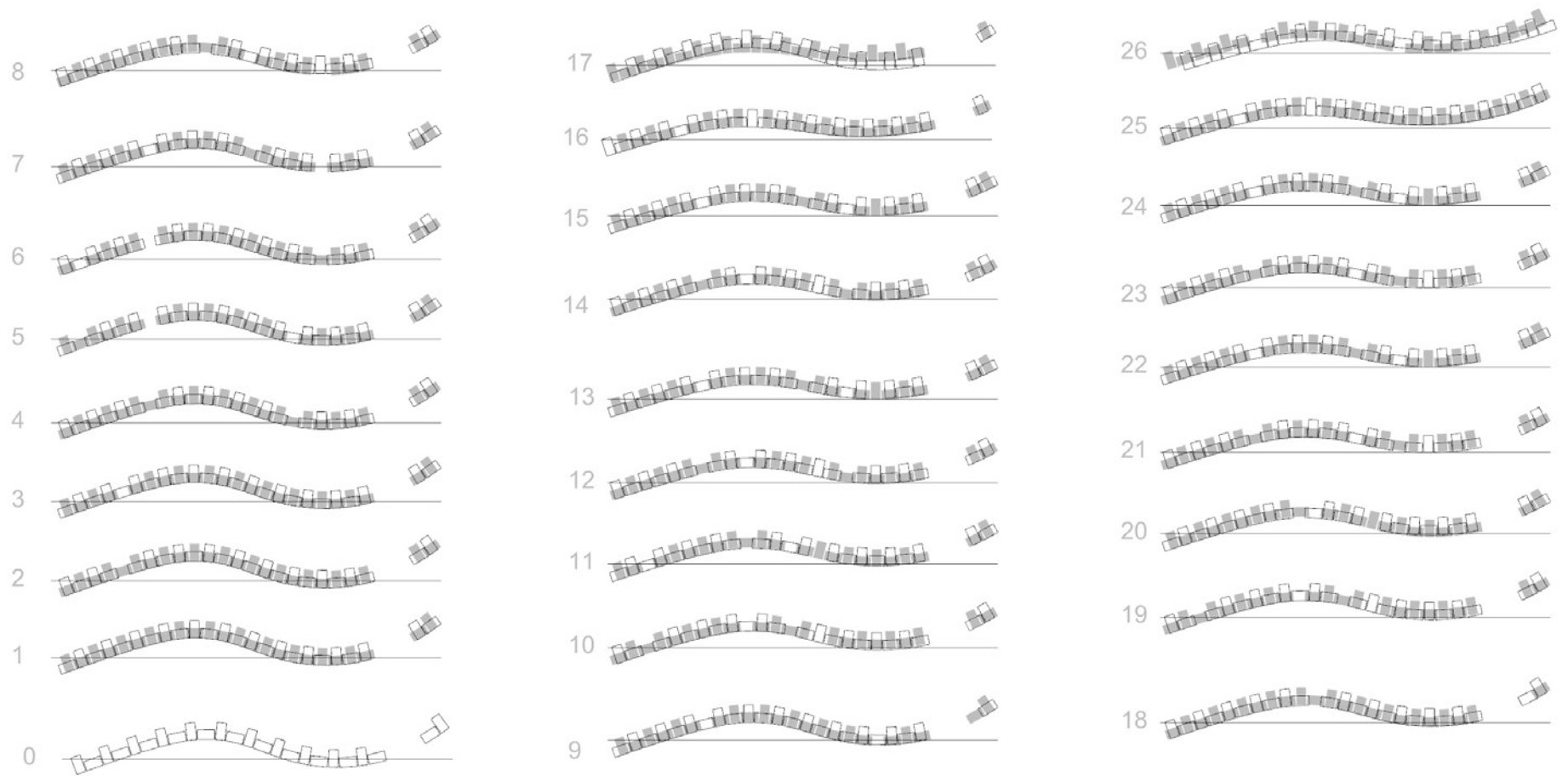

Figure 74: DNA Brick guide

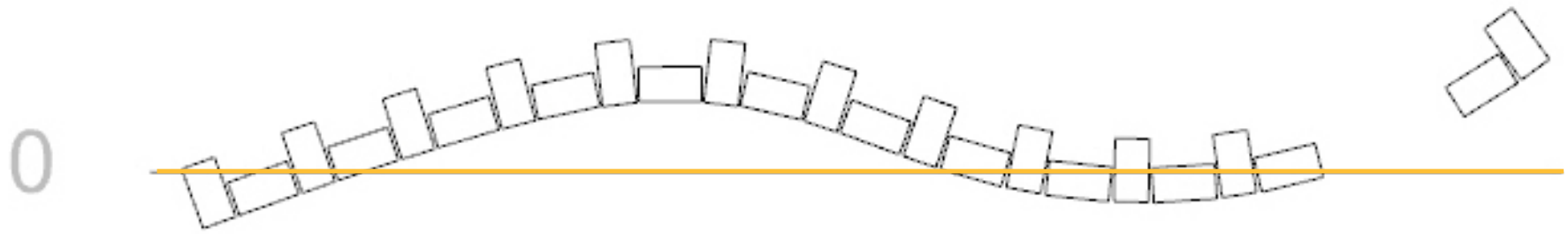

Figure 75: The base level of the DNA brick guide, physically printed

The base of the wall needs a full-scale physical guide and that is the only part of the construction guides that should be printed in the scale of one to one in order to start with the right curvature at the base. The rest of the guide can be printed in a readable scale. Figure 76 shows the guide for one of the courses above the base course of the wall. The solid hatch shows the level below this course and the black lines show the current course.

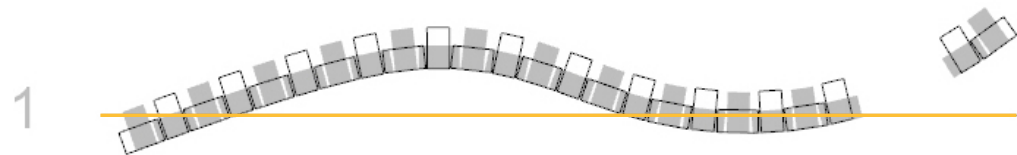

Figure 76: Level 1 of the DNA brick guide

The DNA guides can be printed in the location that the wall is going to be built or can be mailed if there is no access to large printers in project location. If neither printing large nor mailing is an option, the base curve can be drawn on the ground surface according to its mathematical properties.

6.2.2: SMART GUIDES

An area for future investigation in this research, is to study the possibility of using smart guides that also act as horizontal reinforcing elements in the wall. Such guides can be made from different types of mesh material including fabrics, plastic or metal. The guide can be printed with plasma-cutter or fabric-cutter and mailed to construction site. It can be embedded in the bed joint of the wall as long as it allows the mortar pass through its holes. The shape of the guide can add to the precision of wall form and help the mason make sure he is creating the right curvature.

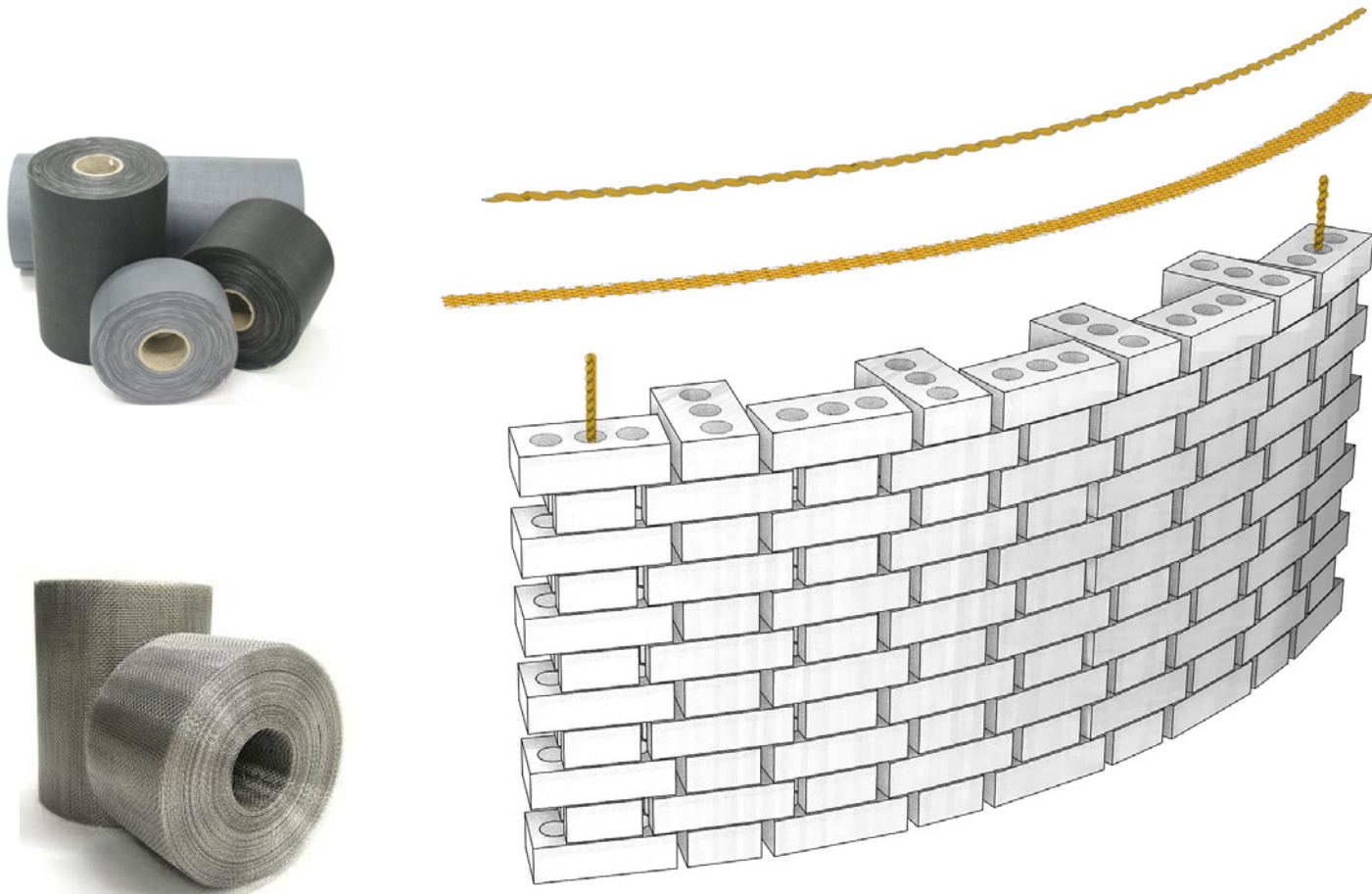

Figure77: Smart metal/plastic/fabric guide

6.2.3: CONSTRUCTION KIT

After creating the DNA guides and perhaps the smart guides, they should be sent to the mason and construction team. They can also print them in construction location if they have access to the right tools. In this process the high-tech piece of the project is the DNA guide, which is a digital or light-weight paper guide (figure 78). The low-tech is the brick and mortar which is heavy and should be available in construction location. The construction kit includes the DNA guide, the brick, mortar and reinforcement bars and mason tools, including the level, trowel, string, mallet, brush and jointer (figure 79).

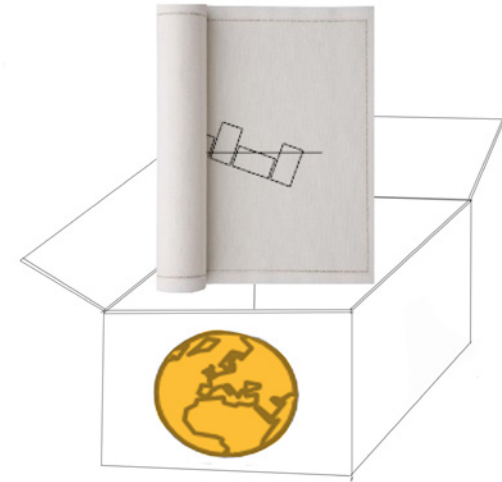

Figure 78: High-tech DNA guide

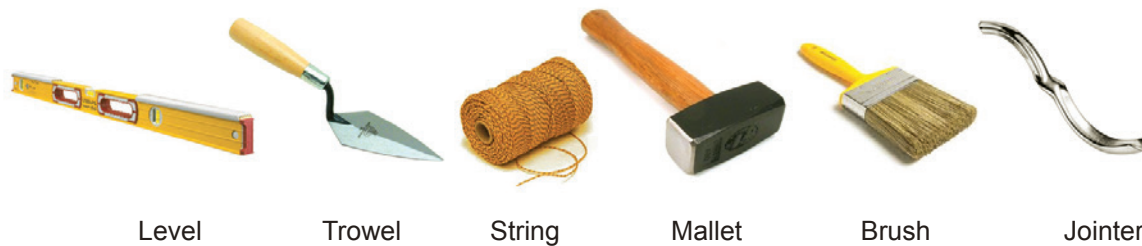

Figure 79: Mason tools and Low-tech building material

6.2.4. CONSTRUCTION SKETCHES

1. The construction process starts by opening the paper guide in the construction site after preparing the base of the wall. The guide can be printed or received via mail.

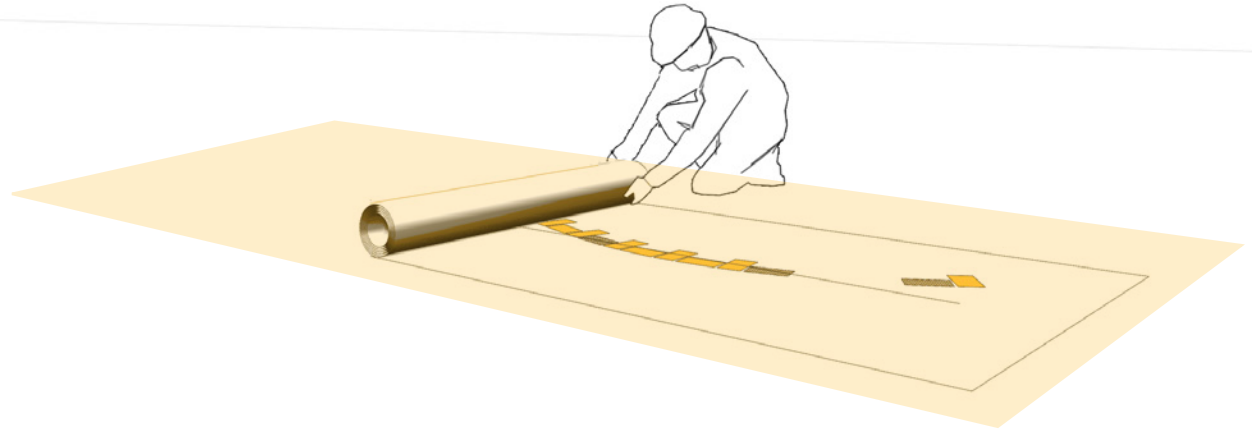

Figure 80: Construction sketch 1: roll the paper guide out

2. The second step is to use the guide to draw the curvature on the base of the wall. Different methods including using a duplication layer, or cutting through the paper and etching the surface, can be used for duplicating the base line on the ground.

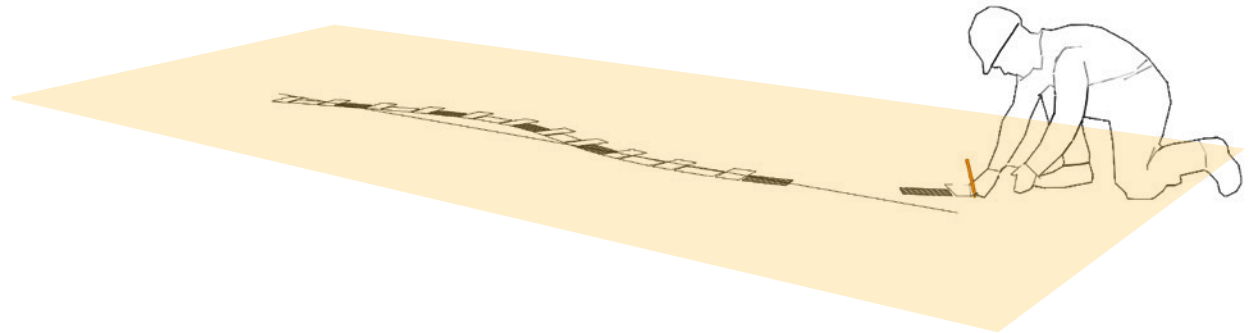

Figure 81: Construction sketch 2: draw the base curve on the ground

3. In next step, the vertical reinforcements for the system can be put in place. In each location the required number of reinforcement bars might be different according to structural requirement and wall form. Therefore in each project a structural engineer should study the system and make suggestions. The reinforcement should be tied to the reinforcing elements of the base. Then the holes should be filled with concrete or its equivalent.

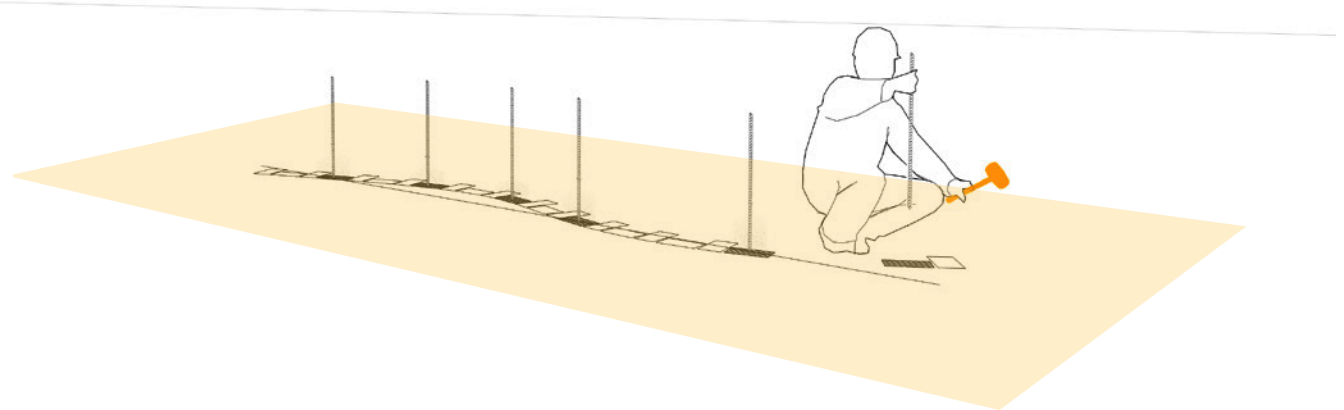

Figure 82: Construction sketch 3: add reinforcement bars

4. Next, the masons can set up the string that will help them to level the brick wall. This stage is similar to any traditional brick construction process. By leveling the string, the mason can easily level each course of brick while building the wall.

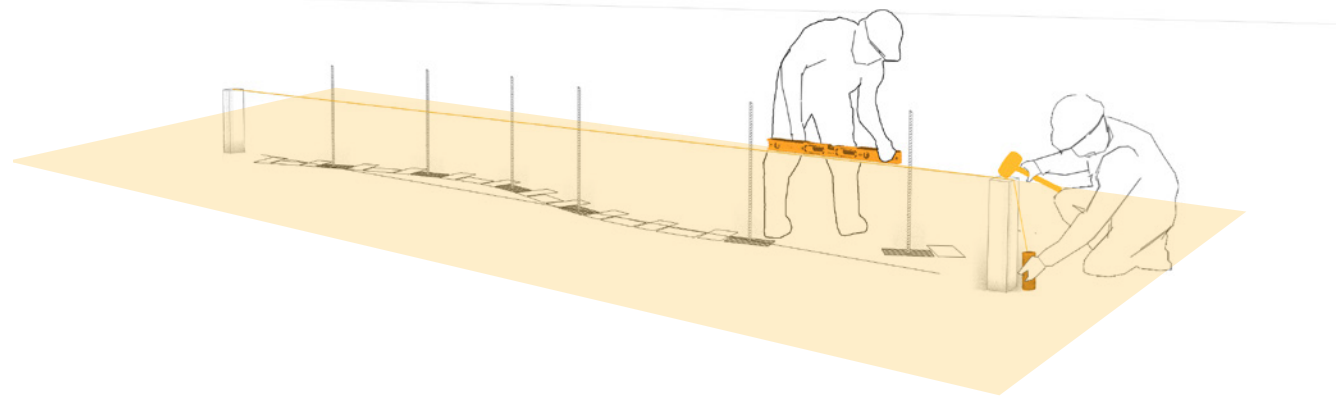

Figure 83: Construction sketch 4: add the string guide

5. In the next step the masons can start building the wall. They should have the DNA guide in a place that is easy to reach and see to put each brick in place according to the guide.

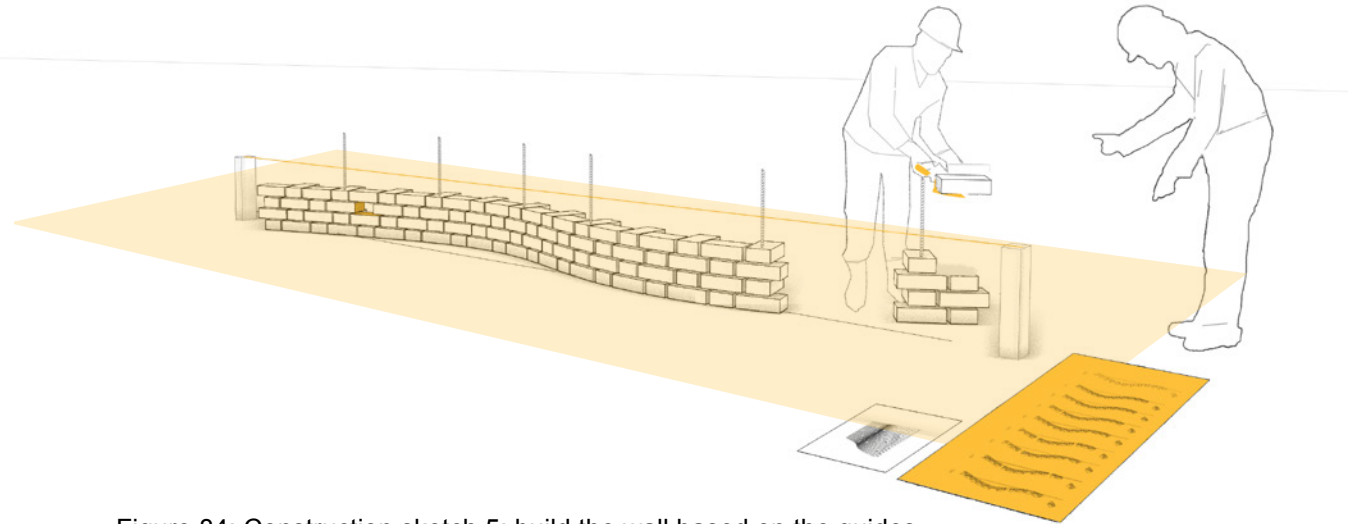

Figure 84: Construction sketch 5: build the wall based on the guides

6. In the next step vertical reinforcement bars can be bent in place to match the curvature of the wall.

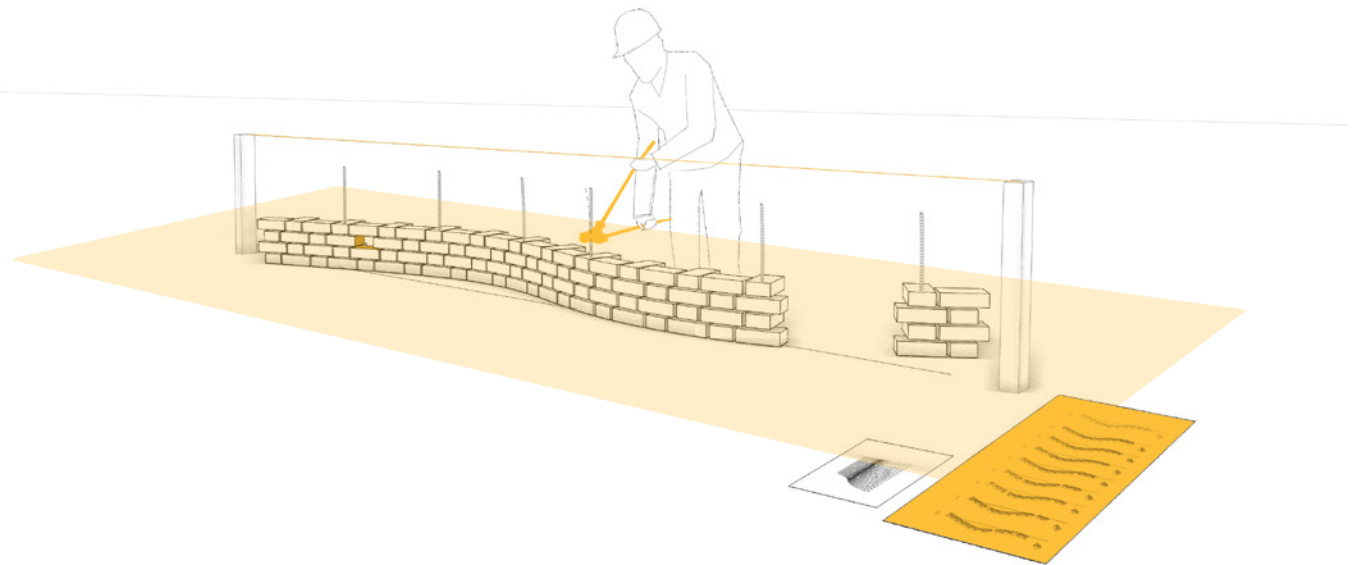

Figure 85: Construction sketch 6: bend the r-bars to match the curvature

7. After reaching a certain height the horizontal reinforcing elements should be added. This height can be different in each location according to structural requirements and the form of the wall.

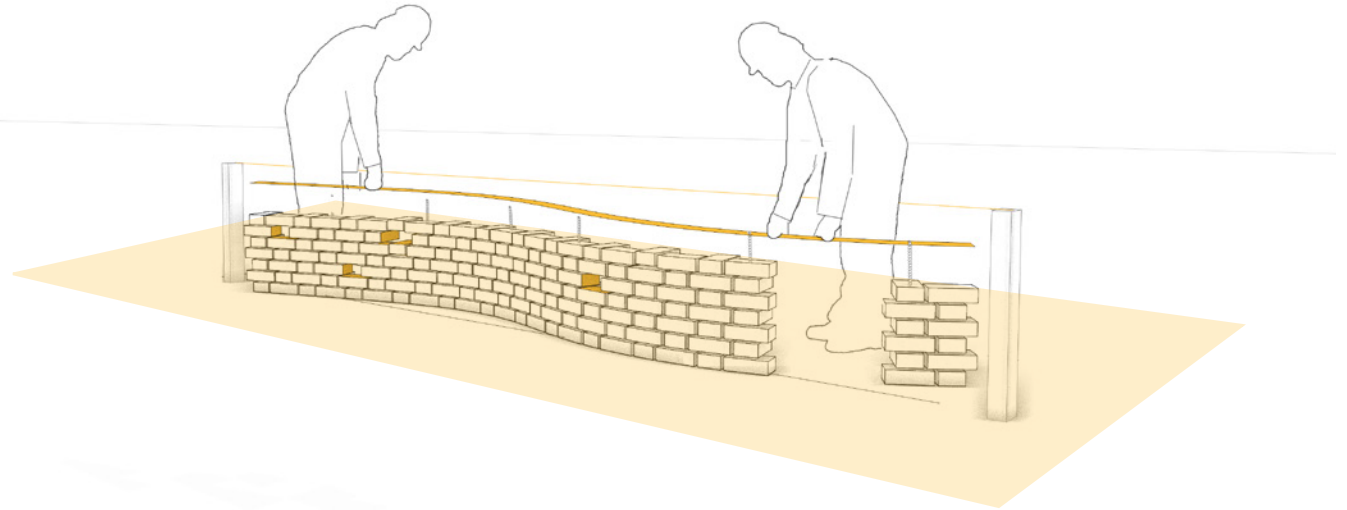

Figure 86: Construction sketch 7: Add horizontal the reinforcement

8. The vertical reinforcement bars can be cut into sections to make it easier for the mason to work with them. After each few courses, new sections can be tied to the ones below until reaching the full height of the wall.

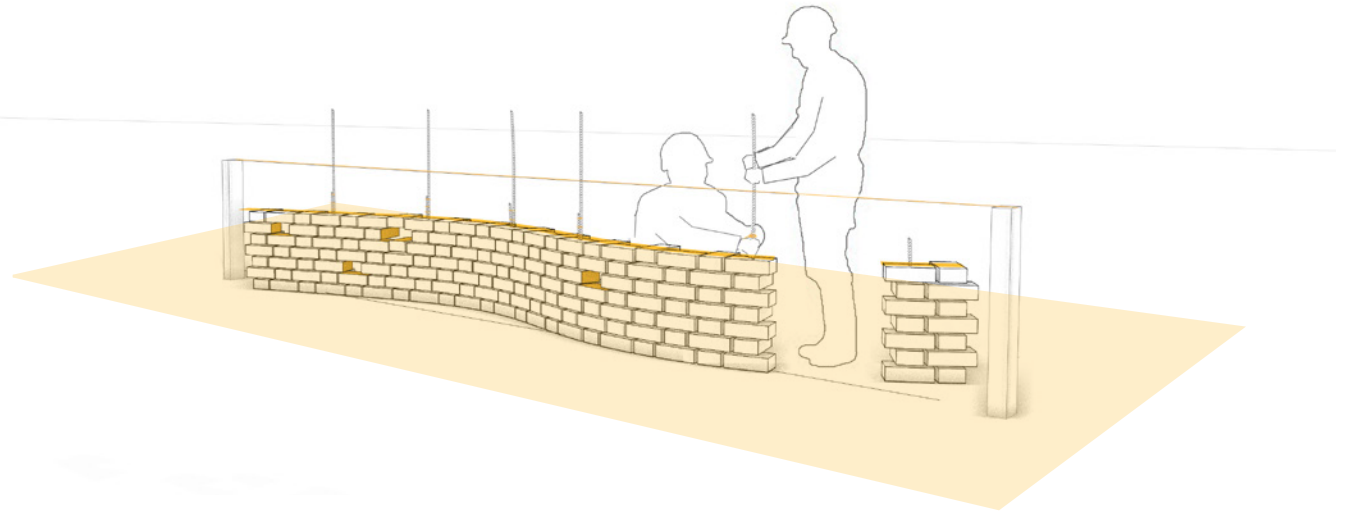
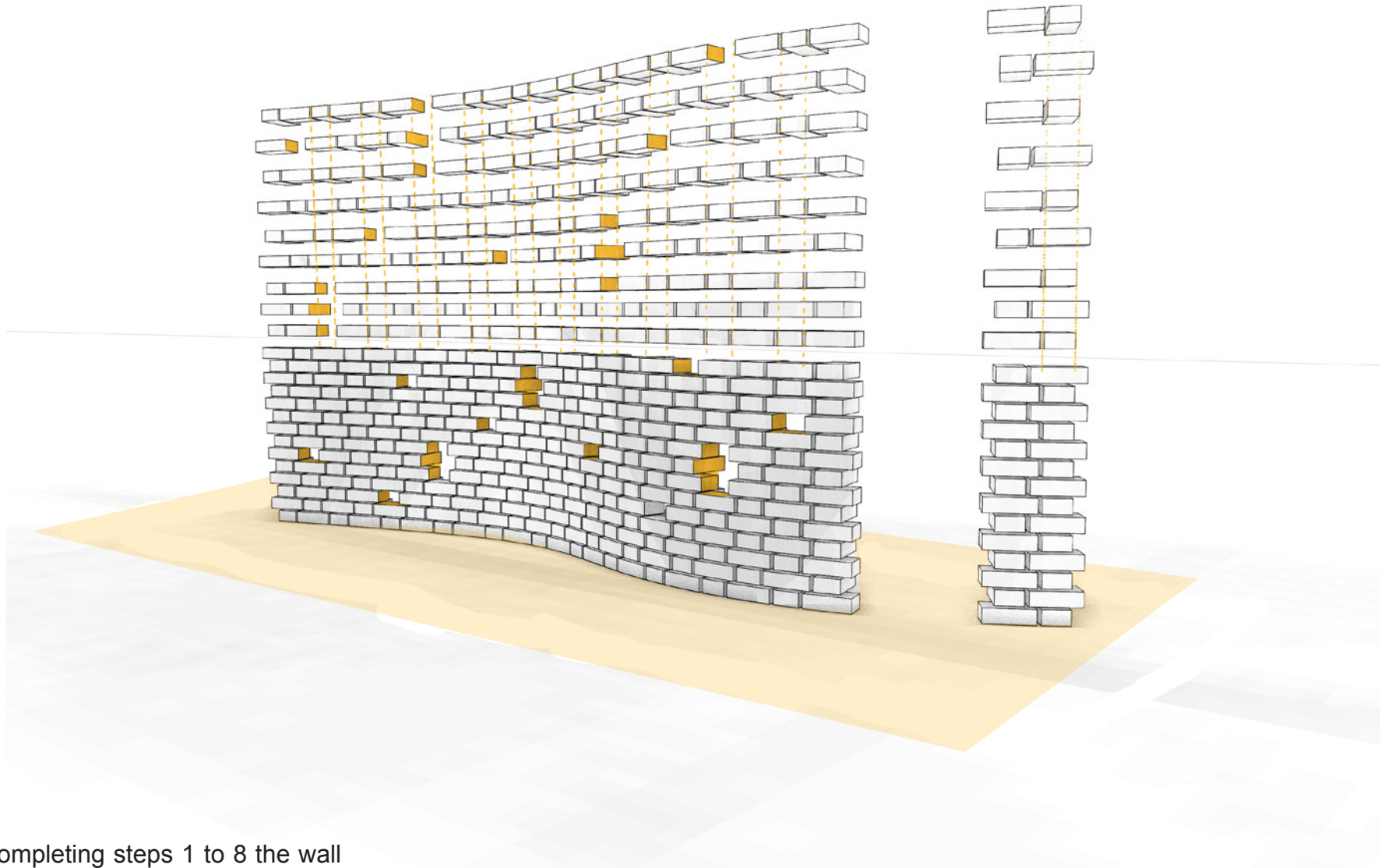

Figure 87: Construction sketch 8: tie the vertical reinforcement bars together



By completing steps 1 to 8 the wall can be built in its full height.

Figure 88: Finishing the wall

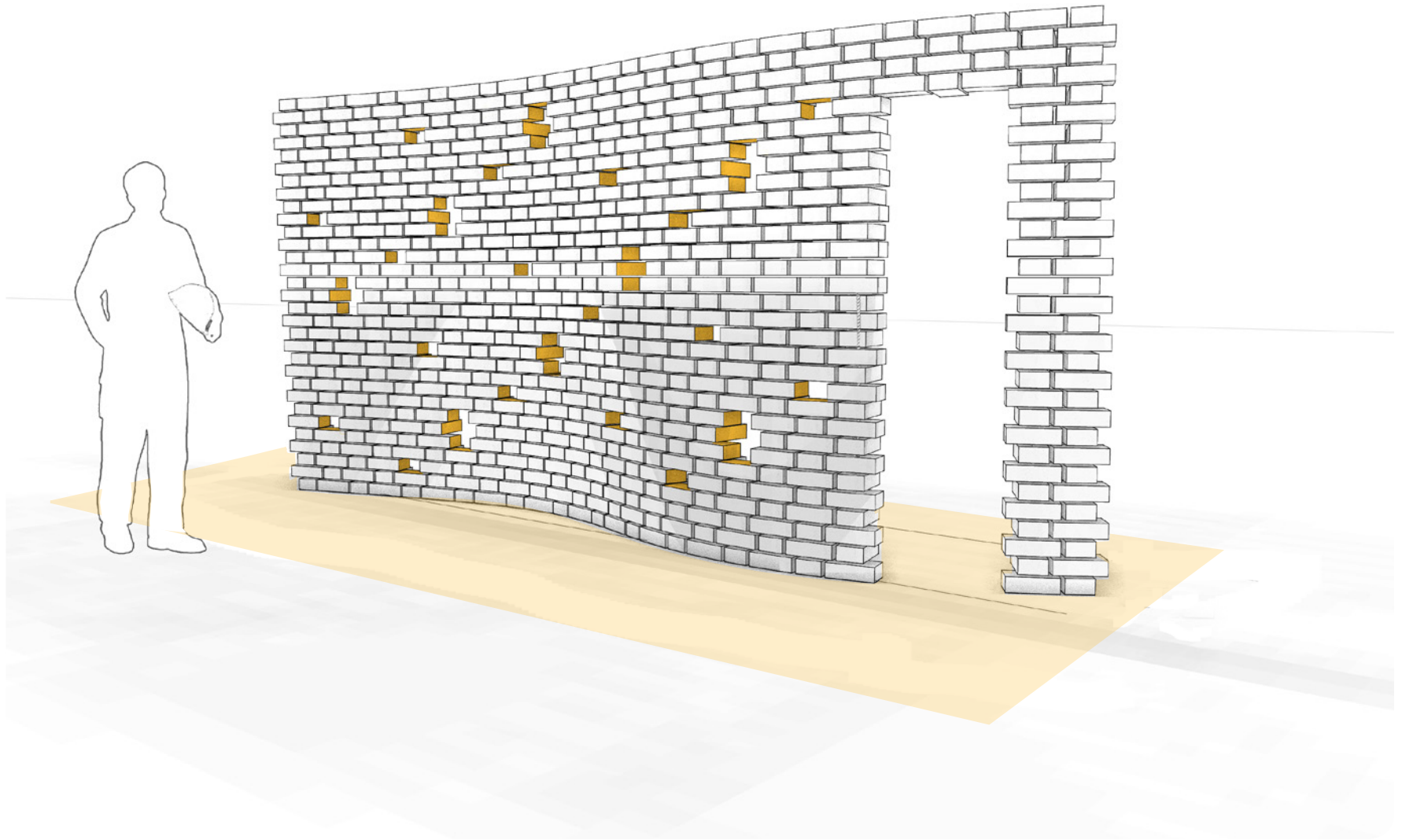

Figure 89: The complete wall



PART 7: PROTOTYPE

In order to test the proposed brick masonry design and construction process, an experimental prototype was built with 150 bricks produced in Seattle. The wall was customized after designing the base wall. The wall steps down in different heights. A few openings are designed within the wall to let the light pass through the screen. A Wooden base was built for the prototype to make it movable (figure 90 to 92).

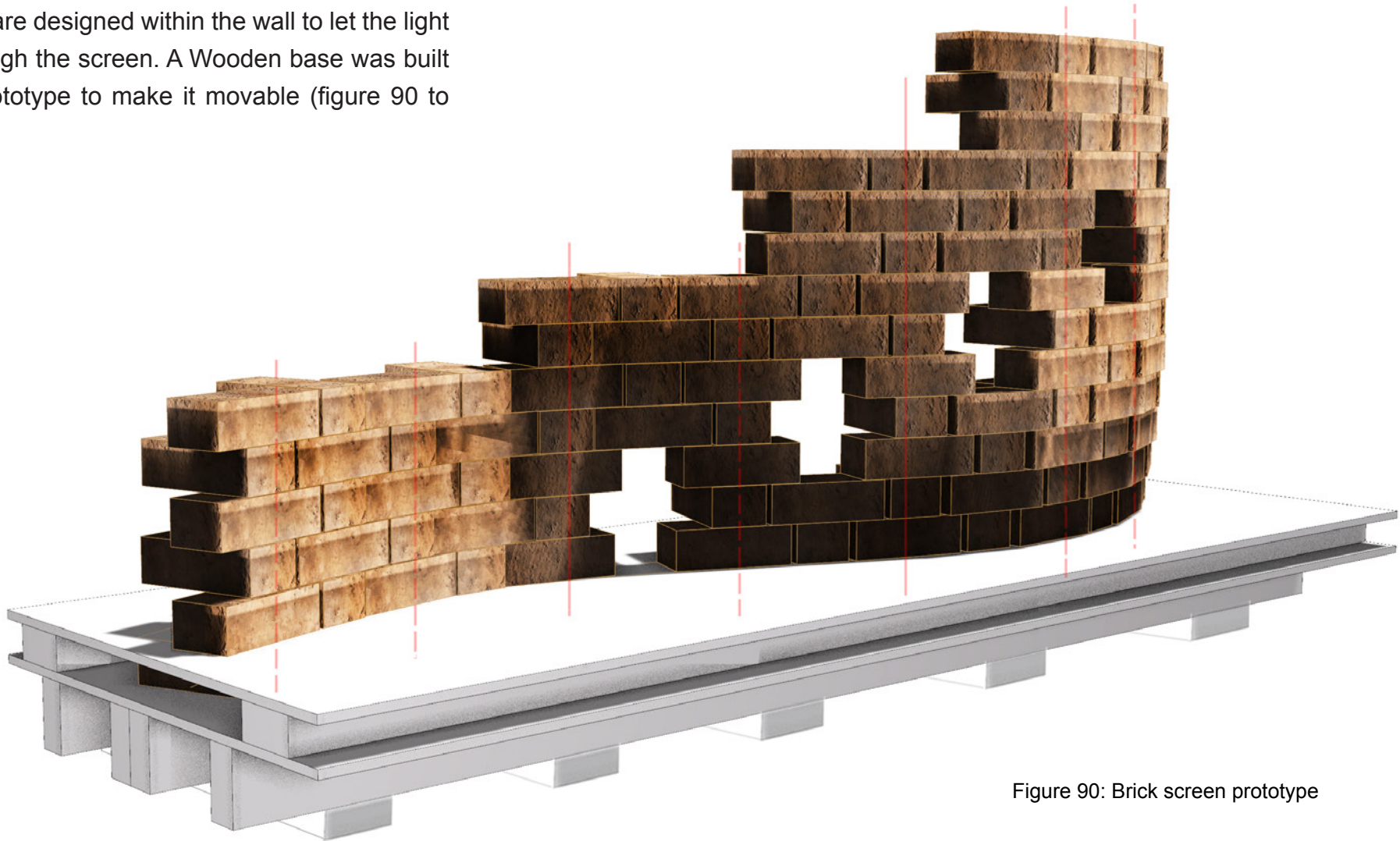

Figure 90: Brick screen prototype

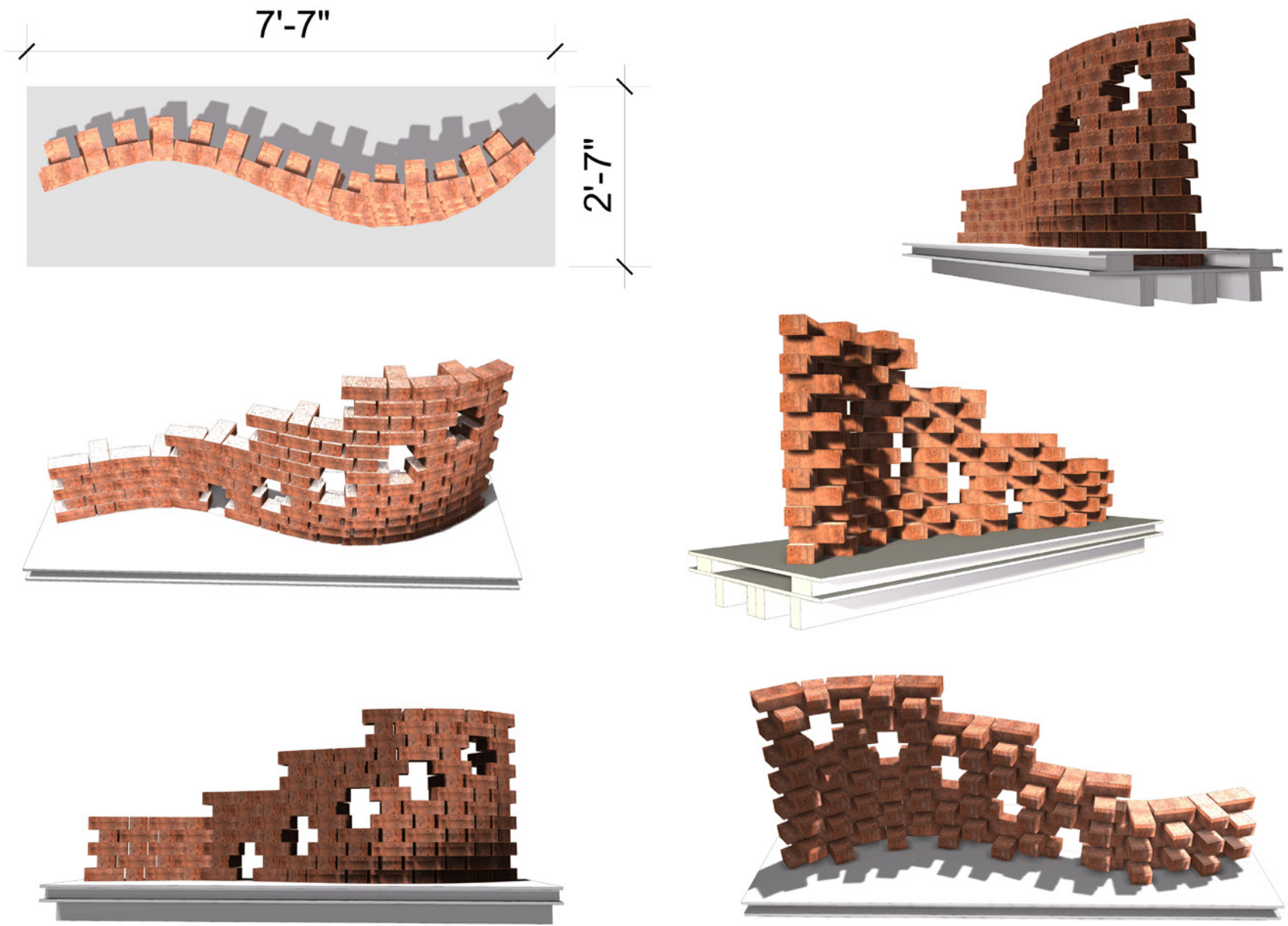

Figure 91: Brick screen prototype renderings

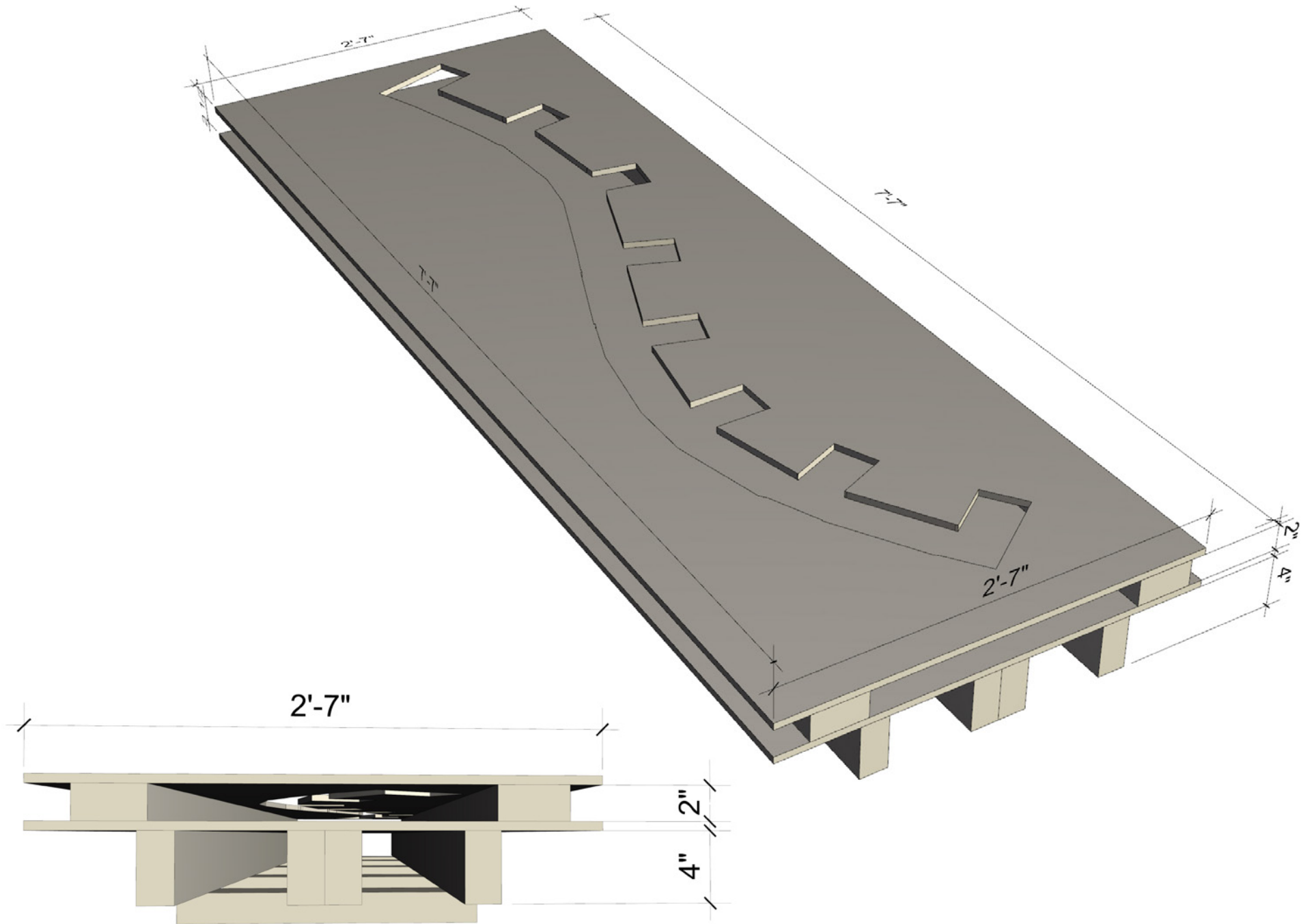

Figure 92: The base of the wall



Figure 93: Building process 1



Figure 94: Building process 2



Figure 95: Building process 3



Figure 96: Building process



Figure 97: Building process

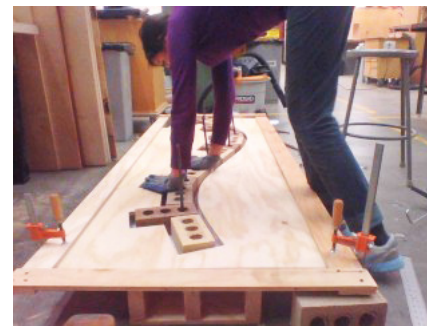

Figure 98: Building process



Figure 99: Building process



Figure 100: Building process 4



Figure 101: Building process 5



Figure 102: Building process 6

The bricks were donated by Mutual Materials and came in three different colors. Vertical reinforcement bars were added to the wall in order to tie it to the wooden base. The base curve was printed in full size and glued to the wooden base. The next brick courses were built according to the guides. I started building this prototype before the DNA guide was fully developed and this construction process helped me to understand how to create a guide that could simply show the process of building each course. The main finding of this process was that the guide for each course needed to show the course below to help the mason visually understand where to place the bricks. I built this wall with the help of two friends and none of us had any experience in masonry construction. The assumption was that if the guides can help us build the wall then they will be useful in instructing masons with more experience. Figure 93 to 126 shows the building process of the wall and the finished prototype.

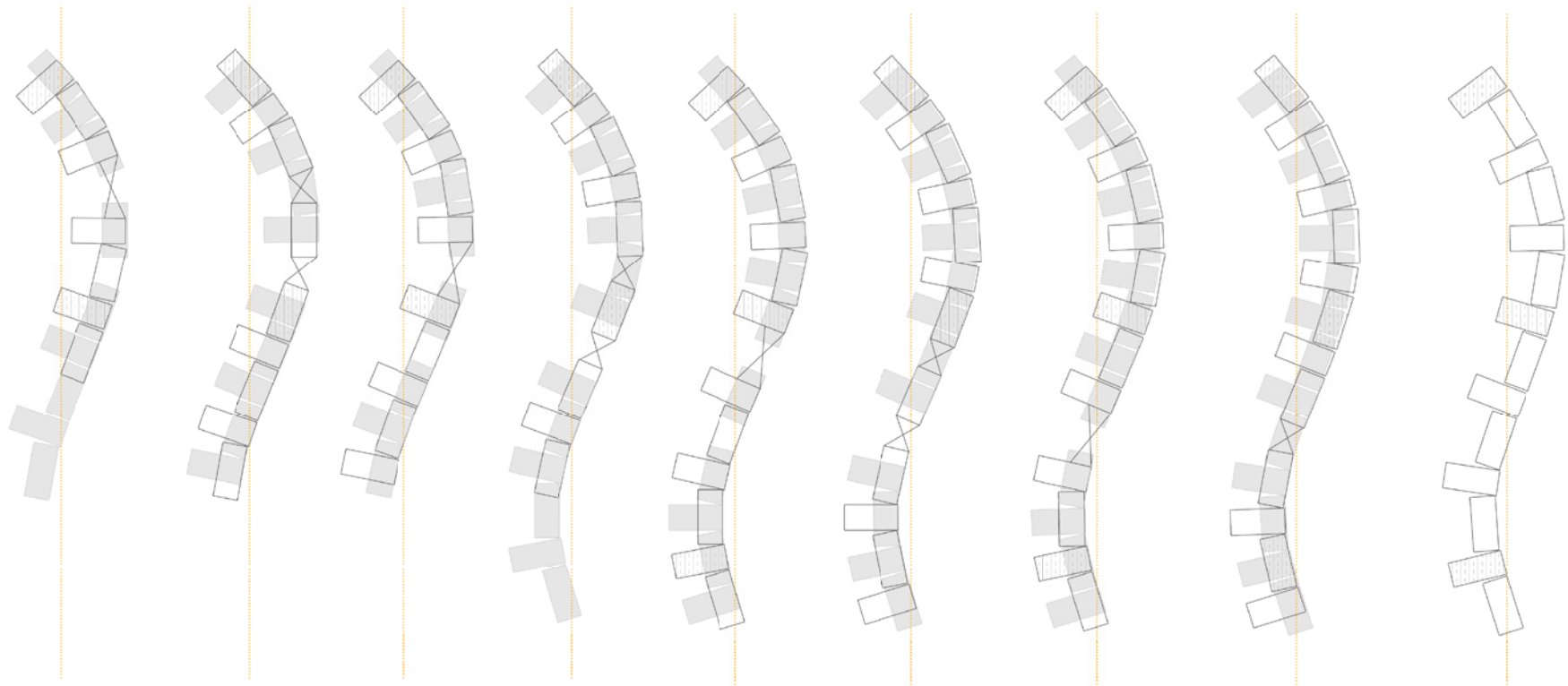

Figure 103: Brick prototype DNA guide

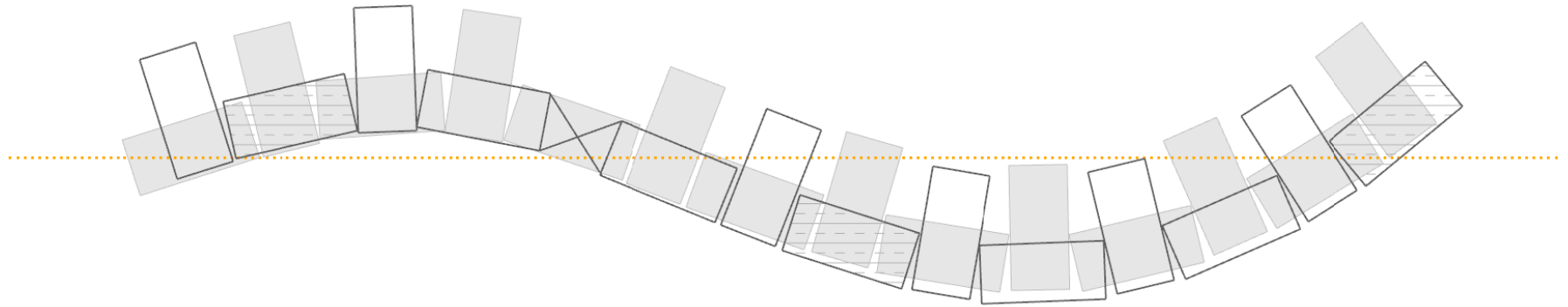

Figure 104: Brick prototype DNA guide, level 1

Figure 105: Building according to the wall





Figure 106: Building process



Figure 107: Building process



Figure 108: Building process



Figure 109: Building process



Figure 110: Building process



Figure 111: Building process



Figure 112 Building process



Figure 113: Building process



Figure 114: Building process



Figure 115: Building process



Figure 116: Building process



Figure 117: Building process

Figure 118: The built prototype





Figure 119 & 120: The built prototype



Figure 121,122, 123: The built prototype

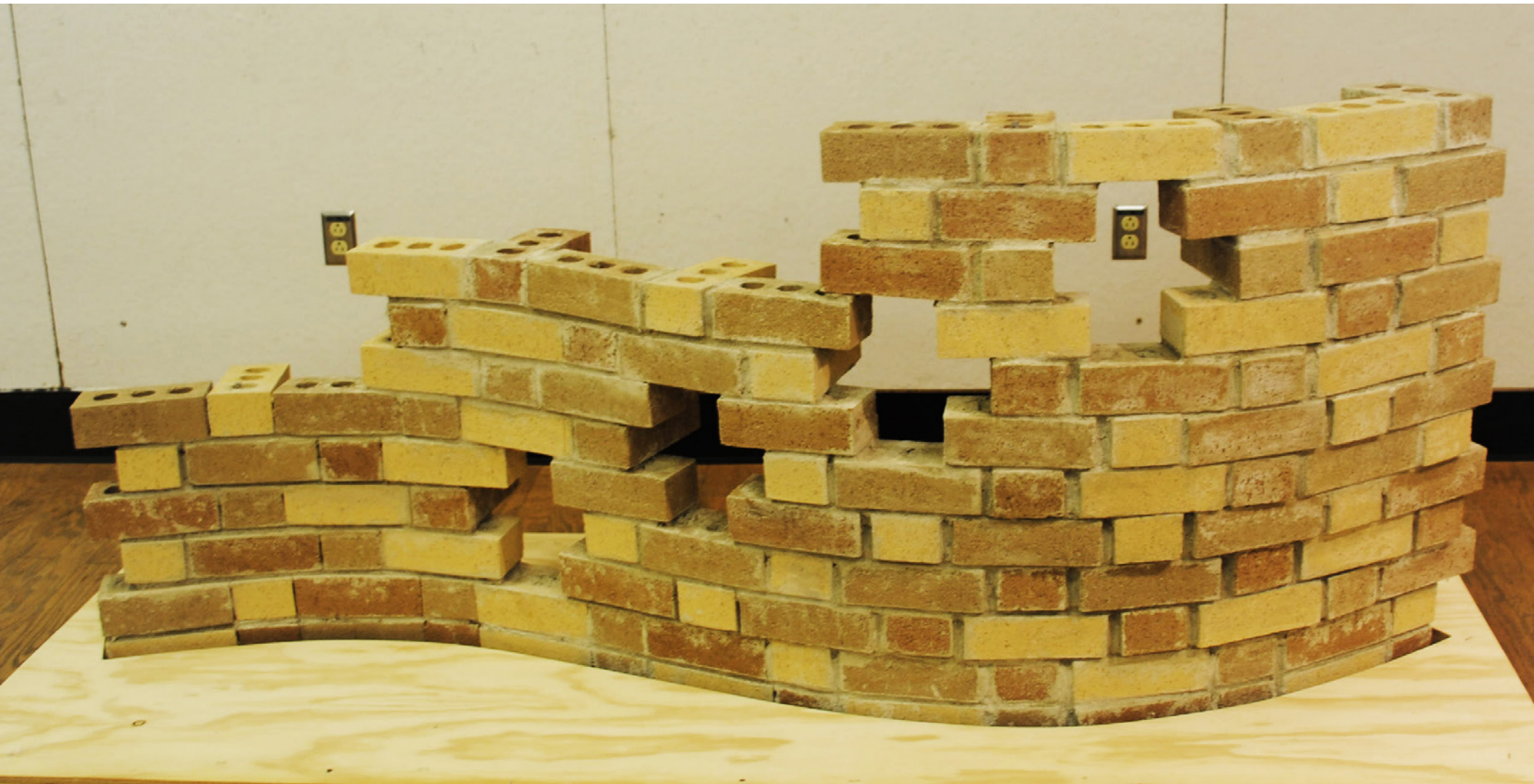

Figure 124: The built prototype



Figure 125: The built prototype



Figure 126: The built prototype

SUMMARY AND FUTURE WORK

This thesis presented a computational parametric process for designing and building a single-layered screen system. Brick, a low-cost and widely available material, along with low-tech construction techniques, was used in creating the screen system. In this approach, high-tech computational software improves the design and construction process of a low-tech, low-cost building system that can be implemented in different locations around the world.

The parametric process is an interactive Grasshopper/Rhino workflow that lets the users work with bricks in a digital realm and have control over how they are laid. This digital process is similar to the way skilled masons historically designed patterns and created forms with bricks. Additionally, it lets the users quickly test and visualize their ideas before actually building them. Therefore, with this tool, a high level of craftsmanship and flexibility can be achieved in creating design options for a contemporary brick screen system. The main parameters that shape this process are the physical properties of brick and mortar, the wall form, the patterns and the environment. The user inputs the brick size, the mortar thickness and the wall size into the workflow to create a base wall. The wall can have a flexible form defined by drawing a surface in Rhino and inputting it to the wall-making component. The user can then design custom brick patterns for the wall. By defining a location, the orientation and the time zone, the user can study the sun's location during the design process and adjust the wall's form and patterned openings according to the desired natural light and shadows created by the wall and bricks.

The challenge addressed in this thesis is the development of a process that is applicable in different locations around the world. This is particularly important today because most architects design projects overseas and their design processes and results must be easy to understand by other designers, masons, and clients. After customizing the design, the tool creates a DNA guide that, along with construction diagrams and drawings, instructs the mason on the assembly of the wall. The DNA guide simplifies the construction process by making it less reliant on skilled masons. Transferring the data to the construction site using simple paper guides lets the mason understand the design requirements and build the screen with low-tech materials and hand tools.

A prototype was made to test this design and construction process which helped in improving the DNA guide. In order to further develop and improve on this construction kit, the process should be applied to different project types in various locations. In the coming months two brick screen systems designed with this design tool will be built in Niamey, Niger and in Mazar-i-sharif, Afghanistan. These two real world examples will help in improving the construction kit as well as the communication between the technology, designers and masons.

The pattern making tool that is created in this thesis is particularly applicable to flat surfaces. Developing the same level of control over pattern-making in walls with flexible forms is among the future steps of this research. The current Grasshopper parameters are programmed for Flemish brick bonding. Similar parametric design process can be created for other types of brick bonding patterns in the future. Also, aside from studying the sun and shadows, other climate-specific factors such as wind direction can be added to the design parameters to improve this tool. The steps that are developed for this tool are interactive and give the user full control over each decision. One important step helps test curved surfaces in terms of their constructability and offers direct feedback to the user. A similar approach can improve other steps of the process by providing direct feedback to the user while making design choices. This design tool and its future iterations will create a flexible process that makes it possible to bridge the gap between the designer and the mason and to accurately simulate the environment of various locations in order to create adaptive and sculptural brick patterns and forms.

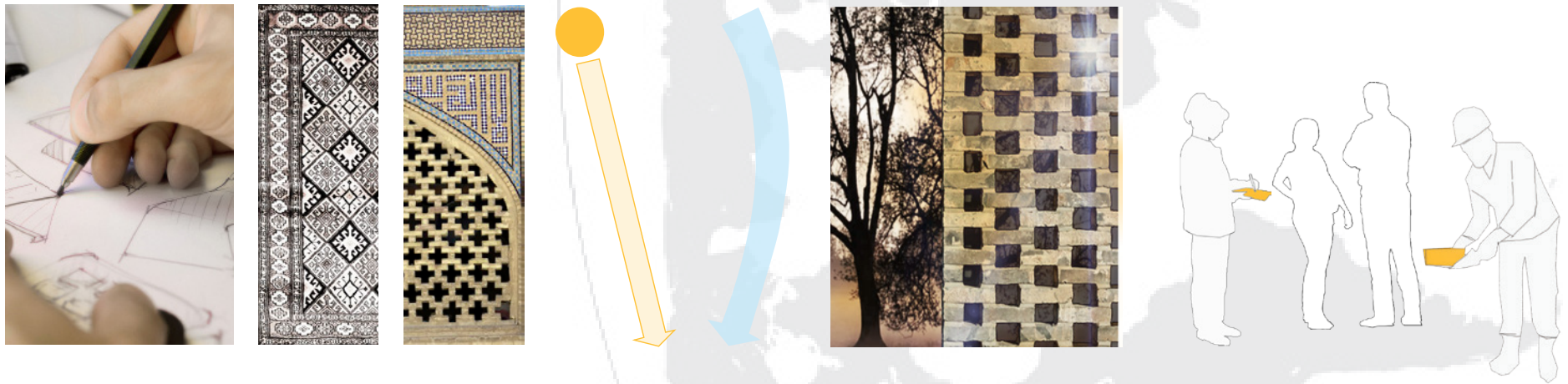

BIBLIOGRAPHY

- Alexander, Christopher, *The timeless way of building*, (Oxford University Press, 1979), p8.
- Archer, Bruce, "The nature of research", *Interdisciplinary journal of design*, pp 6-13 Jan 1995.
- Bhatia, Gautam, *Laurie Baker, life, work, writings* (Viking 1991), p15.
- Brick Pattern House by Alireza Mashhadimirza, accessed Nov10, 2013, <http://www.designboom.com/readers/brick-pattern-house-by-alireza-mashhadimirza/>
- Center for Climate and Energy Solutions, accessed Nov20, 2013, <http://www.c2es.org/technology/factsheet/BuildingEnvelope>.
- DNA Assembly, accessed Jan 10, <http://wyss.harvard.edu/viewpage/409/>.
- Earthen architecture, accessed May 15, <http://eartharchitecture.org/>.
- Earthen Architecture in the world, accessed May 15, 2014, <http://zemnostroitelstvo.net/>.
- Feringa, Jelle, "Implicit fabrication, fabrication beyond craft: the potential of turning completeness in construction," *ACADIA* pp. 383-90, 2012.
- Foerster, Bernd, *Pattern and Texture*, (Allied Masonry Council 1961), p.7.
- Fampton, Kenneth, *Modern Architecture: A Critical History*, (Thames & Hudson 2007), p3.
- Gramazio and Kohler, *Architektur und Städtebau.: 2013. Gantenbein Winery project*, accessed Oct 10, <http://www.gramaziokohler.com/>.
- Grasshopper, Algorithmic modeling for Rhino, accessed Nov20, 2013, <http://www.grasshopper3d.com/>.
- Holzer, D., R. Hough, and M. Burry. (2007). Parametric Design and Structural Optimization For Early Design Exploration. *International Journal Of Architectural Computing* 5(4): 625-43.
- John Naisbitt, *high-tech.high-touch*, (Broadway Books 1999), p27.
- Ladybug + Honeybee, accessed Nov20, 2013, <http://www.grasshopper3d.com/group/ladybug>.
- Lechner, Norbert, *Heating, Cooling, Lighting: Sustainable Design Methods for Architects*, (Wiley 2014), p8.
- Pavlíček, Jiri; Kaftan, Martin, "Parametric Design System for Passive Houses," *Proceedings of the 30th eCAADe Conference*, 2012.
- Petrovic, Pavel, "Solving LEGO brick layout problem using Evolutionary Algorithms", *Proceedings to Norwegian Conference on Computer Science*, 2001.
- Ronald Rael, *Earth Architecture*,(Princeton Architectural Press 2010), p9.
- Thompson, Darcy, *On Growth and Form*, (Cambridge University Press, 1992), p269.
- TED talk by Alastair Parvin, accessed Sep 25, 2014, http://www.ted.com/talks/alastair_parvin_architecture_for_the_people_by_the_people?language=en.
- Toth, Bianca; Flora Dilys Salim, Robin Drogemuller, John H. Frazer and Jane Burry, "Closing the loop of design and analysis: Parametric modelling tools for early decision support." *Proceedings of the 16th International Conference on Computer Aided Architectural Design Research in Asia / The University of Newcastle*, pp. 525-534, Australia, 2011.
- United Nations Water, accessed Sep 15, <http://www.unwater.org/water-cooperation-2013/water-cooperation/facts-and-figures/en/>
- World population, accessed May 15, 2014, <http://www.worldometers.info/world-population/>.
- 3-D printing helps designers build a better brick, accessed Sep 10, <http://www.news.cornell.edu/stories/2014/07/3-d-printing-helps-designers-build-better-brick>.