

# **GlareShade:**

a visual comfort based approach to adaptive shading systems

Alireza Hashemloo

A thesis

submitted in partial fulfillment of the  
requirements for the degree of

Master of Architecture

University of Washington

2014

Committee:

Mehlika Inanici

Christopher Meek

Program Authorized to Offer Degree:

Architecture

© Copyright 2014  
Alireza Hashemloo

University of Washington

## **Abstract**

**GlareShade:**

a visual comfort based approach to adaptive shading systems

Alireza Hashemloo

Chair of the Supervisory Committee:

Associate Professor Mehlika Inanici

Department of Architecture

The thesis investigates design solutions for an adaptive shading system in high-rise office buildings. High density of occupants, variation in comfort levels corresponding with different activity types and individuals' preferences, diverse occupation schedules and maximized exposure to outside environment relative to construction footprint exemplify the complexities associated with daylight control strategies in high-rise office buildings. Precedent daylight control strategies fail to address the glare issue and relative complexities associated with variation of criteria for occupants' comfort. The thesis proposes a new method to evaluate glare issue relative to an individual's viewpoint and identifies the problematic region(s) on corresponding glazing surface(s) that can be addressed with an adaptive shading system.



**GlareShade:**  
a visual comfort based approach to adaptive shading systems

- University of Washington
- College of Built Environment
- Master of Architecture Thesis
- Spring 2014
  
- Alireza Hashemloo
- Thesis Committee Chair: Mehlika Inanici
- Thesis Committee Member: Christopher Meek

# Table of Contents

## **Chapter 1: Introduction**

- 1.1 Introduction
- 1.2 Daylight Control Metrics: Glare Issue
- 1.3 Target Building Type:  
High-rise Office Use
- 1.4 Objectives
- 1.5 Summary of thesis content

## **Chapter 2: Adaptive Shading Systems: Precedent Case Study**

- 2.1 Chapter Contents Summary
- 2.2 Precedent Adaptive Shading Systems

## **Chapter 3: Adaptive Shading Systems: Deployed Daylight Control Metrics**

- 3.1 Chapter Contents Summary
- 3.2 Occupants' Visual Comfort
- 3.3 Occupants' Visual Comfort:  
Evaluation Metrics
- 3.4 Energy Consumption Efficiency
- 3.5 Energy Consumption Efficiency:  
Evaluation Metric

## **Chapter 4: Building Program & Site Analysis**

- 4.1 Chapter Contents Summary
- 4.2 Form Generation & Analysis Tools
- 4.3 Building Program: The Specifications of a Study Model for Simulation
- 4.4 Study Model Parameters
- 4.5 Method of Investigation
- 4.6 Site Analysis

## **Chapter 5: The GlareShade Method**

- 5.1 Chapter Contents Summary
- 5.2 The GlareShade Method
- 5.3 GlareShade method & development of an adaptive shading systems
- 5.4 ShadeFan: an adaptive shading system utilizing the GlareShade method
- 5.5 ShadeFan System: primary concepts and characteristics

## **Chapter 6: The GlareShade Method Evaluation**

- 6.1 Chapter Contents Summary
- 6.2 Examination of GlareShade method

## **Chapter 7: Conclusions**

- 7.1 Chapter Contents Summary
- 7.2 Underlying Metrics in GlareShade Method
- 7.3 Adaptive Shading Systems Utilizing the GlareShade method
- 7.4 GlareShade Method: Primary Features



Chapter 1  
**Introduction**

## **Introduction:**

The building façade is the primary tectonic assembly through which physical interactions with surrounding environment transpire. These physical interactions include structural resistance against wind loads, thermal insulation, natural ventilation, daylight harvesting, solar heat gain, etc. In addition, the building façade signifies the predominant qualities a building is identified for within a larger context. Considering the building as a living organism, the façade is the skin through which, diverse functions of control and adaptation to outside environment are executed.

The primary control layers within a building façade are categorized as:

- Daylight Harvesting
- Natural Ventilation
- Moisture Insulation
- Thermal Insulation
- Sound Insulation
- Structural Resistance

Among the control systems integrated with building façades, the daylight harvesting system is pivotal to enhance the quality of interior spaces relative to occupants' visual comfort and energy consumption efficiency. The performance of the daylight harvesting system significantly impacts buildings' adaptation capacity in response to the dynamic condition of outside environment.

The strategies to control shading devices in daylight harvesting systems are challenged with issues of performance efficiency relative to the dynamic nature of daylight conditions, conflicts on occupants' preferences and the aesthetics of the entire system as the representative component of building facade. The applied strategies to control the interior daylight conditions incorporate individual methods of evaluation & response relative to distinct daylight distribution metrics. The performance of a daylight harvesting

system, therefore, is derived by the efficacy of deployed control methods for evaluation of interior daylight distribution metrics, regulation of the necessary responses and the functionality of shading devices to adequately execute the regulated responses.

### Daylight Control Metrics: Glare Issue

Glare is a visual discomfort experience. Discomfort glare is “a sensation of annoyance or pain caused by high luminance in the field of view”<sup>1</sup>. The experience of glare problem is prevalent at interior spaces. The assessment of glare problem is subordinate to the luminance distribution pattern within an individual’s point of view on a point-in-time basis. The experience of the glare problem at daylit interior spaces is not limited to situations where the disk of the sun is within an individual’s point of view. Uncontrolled reflective facades of exterior built environment is another common source of glare discomfort at interior spaces. The dependency of glare problem verification to individual viewpoints, diverse occupants’ preferences relative to tolerable range of luminance values and the alterations in the extent of visual discomfort as well as the location of glare source relative to an individual’s viewrange due to the dynamic nature of daylight distribution patterns exemplify the complexities associated with glare control methods. The precedent daylight control strategies fail to present a global



Figure 1-1: Glare issue at interior office space  
UCSD Facilities Design and Construction, San Diego  
© Craig Johnson



Figure 1-2: High-rise office buildings, Downtown Seattle

solution based on which, the identified glare issues relative to individual points of view at a given interior space could be addressed exclusively with an adaptive shading system. The thesis investigation, therefore, is concentrated on developing a global sensing approach to address the glare issue for any number of viewpoints at a given interior space as well as developing an adaptive shading system that is capable of executing the responses regulated by the new method.

### **Target Building Type: High-rise Office Use**

High density of occupants, maximized exposure to outside environment relative to construction footprint, variable activity types and furniture layouts while occupying a typical floor plate, variable occupancy schedules relative to individual activity types and variations in occupants' comfort criteria exemplify the complexities associated with daylight control strategies in high-rise office buildings. Considering the consolidation of these complexities in one building type, the high-rise office building is identified as the target building type to develop a study model for thesis investigations.

### **Objectives:**

Precedent daylight control methods fail to address the glare issue and relative complexities associated with variation of criteria for occupants' comfort. The thesis investigates design solutions for an adaptive shading

system in high-rise office buildings. The goal of the thesis is to develop a new glare control method capable of evaluating the glare issue relative to an individual's viewpoint and identifying the problematic region(s) on corresponding glazing surface(s) of the façade assembly that can be addressed with an adaptive shading system.

### **Summary of thesis content:**

The thesis investigation is explored in seven chapters. Precedent applications of adaptive shading systems are presented in chapter 2. Metrics and evaluation tools of daylight control strategies in precedent adaptive shading systems are explored in chapter 3. The building program and site analysis relative to development of a study model are described in chapter 4. Chapter 5 introduces a new glare control method called "GlareShade". The development of a new adaptive shading system based on the GlareShade method is also demonstrated in chapter 5. Evaluations of GlareShade method's capability to address the glare issue at interior spaces are presented in chapter 6. Conclusions exploring the primary features of the GlareShade method and its advantages in comparison with precedent glare control methods are presented in chapter 7.

Chapter 2  
**Adaptive Shading Systems:  
Precedent Case Study**

## Chapter Contents Summary:

This chapter explores precedent designs and application of adaptive shading systems. The method of inquiry executed is as follows:

- i. Identification of adaptive shading systems deployed in northern latitudes with distinct climatic conditions
- ii. Exploration of shared operational features among the studied cases
- iii. Categorization of the case studies according to identified shared operational features

## Precedent Adaptive Shading Systems

Primary operational features of investigated cases are identified:

- **Collateral vs. Divergent:**

regulates the spatial relationship between shading devices' direction of operation and the position of glazing plane. Considering a 3D coordinate system with the x and y axis parallel to the glazing plane and the z axis as perpendicular, Collateral systems include shading devices with 2D dynamics limited to a parallel glazing plane. Thus, shading systems

categorized as “Collateral” represent 2D motions in the x and y plane and/or in-plane rotations around z axis. Divergent systems, on the other hand, represent shading devices with operation planes divergent to the corresponding glazing plane. Shading systems categorized as “Divergent” have the flexibility for 3D motions outside of a parallel glazing plane

- **Motor-driven vs. Sensory-driven:**

regulates the source of the drive force that makes shading devices to execute a transition. Shading devices in a “Motor-driven” system receive the driving force from a separate motor. Thus, the shading systems categorized as “Motor-driven” are incapable of operating any transitions without a motor force and will remain as static. Shading devices of a Sensory-driven system, on the other hand, generate the driving force from inherent physical/chemical reactions to environmental forces and are independent of a motor to complete a transition.

- **Micro-scale Responsive vs. Macro-scale Responsive:**

Regulates the scale of transitions made for a specified shading state. The systems identified as “Micro-scale Responsive” execute shading operation at a scale, where the final effect of such transitions is perceptible with unaided eyes; but the transition process is not visible. The Macro-scale Responsive systems, on the other hand, execute shading operation at a scale, where the transition process is perceptible with unaided eyes such as the apparent movement of shading components.

Collateral	✓
Divergent	
Motor-driven	✓
Sensory-driven	
Micro-scale Responsive	
Macro-scale Responsive	✓

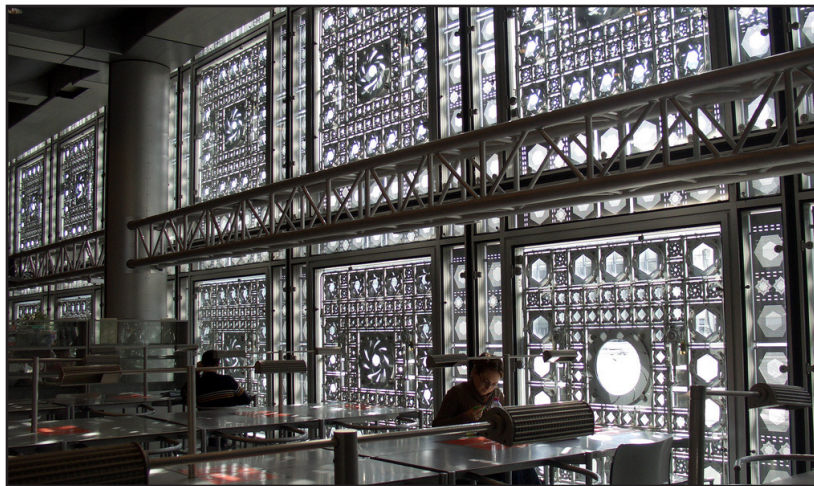

## Arab World Institute

Institut du Monde Arabe

- Location: Paris, France
- Project Year: 1987
- Architect: Jean Nouvel

Diaphragms incorporated with glazing panels control the extent and distribution of daylight at interior spaces. Individual alterations in diaphragms' shape leads to a dramatic distribution pattern of direct light patches. However, the quality of produced lighting conditions relative to specific requirements of individual visual tasks remains debatable. According to documented visualization of interior spaces, the dramatic aspect of lighting condition appears to conflict with conventional criteria for corresponding visual tasks. For example, published visualization of a library space illustrates large areas of desk surfaces under direct solar patch. Despite the creation of an eye-grabbing drama, applied daylight distribution interferes with specific requirements of executed visual tasks such as reading and writing.<sup>1</sup>

## Simons Center for Geometry & Physics

State University of New York at Stony Brook

- Location: Long Island, NY
- Project Year: 2010
- Shading System Designer: ABI
- Adaptive Shading Coverage: 38 sq. meters
- Material: Waterjet-cut stainless steel, glass
- Dimensions: 5.6m Wide x 6.7m Tall

The system consists of perforated metal/plastic plates installed as parallel screens. In-plane shifts in the position of individual screens create a dynamic integration of opacity and transparency. As a result, the system regulates the distribution of daylight through variations in juxtaposition of screens.

Customizable perforation pattern as well as controlled kinetics of individual screens relative to target level of transparency results a high capacity for adaptation to distinct lighting conditions.<sup>2</sup>

Collateral	✓
Divergent	
Motor-driven	✓
Sensory-driven	
Micro-scale Responsive	
Macro-scale Responsive	✓

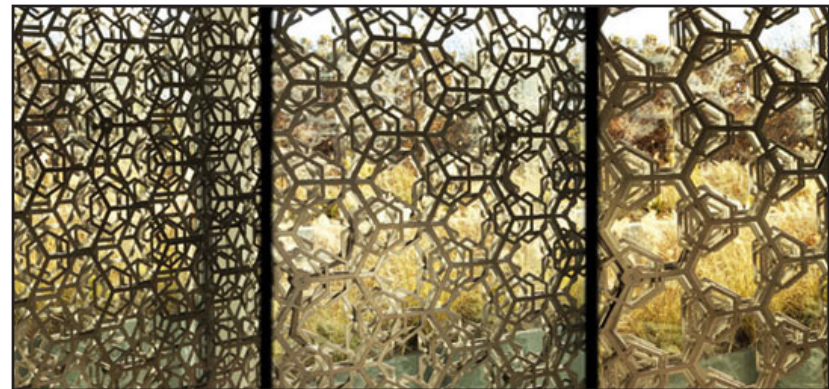
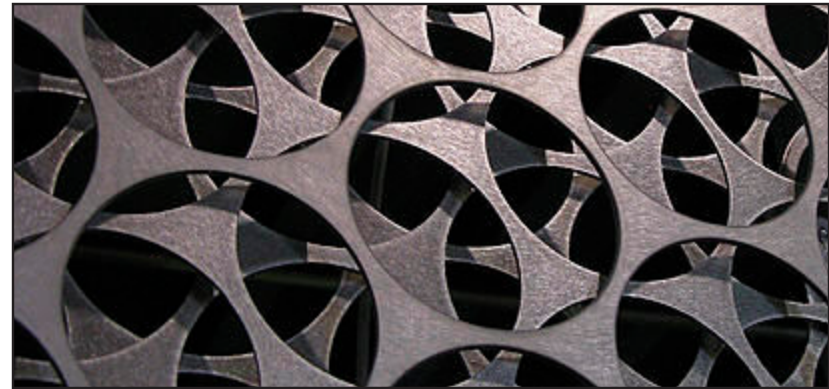

Collateral	
Divergent	✓
Motor-driven	✓
Sensory-driven	
Micro-scale Responsive	
Macro-scale Responsive	✓

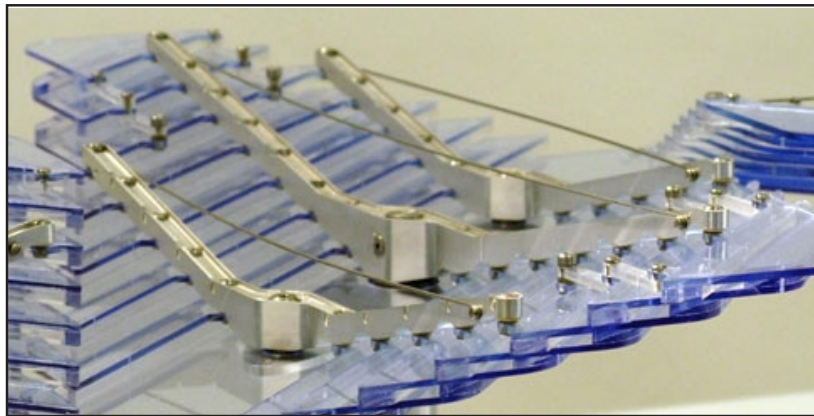

## Center for Architecture

- Location: New York, NY
- Project Year: 2010
- Façade System Designer: SOM
- Shading System Designer: ABI
- Façade System: HelioTrace™
- Shading System: Strata™

The Strata shading system consists of retractable slats capable of executing three-dimensional transitions. Electric motors conduct the transition tasks by controlling the dynamics of individual slats. Consequent versatility results in a broad range of shading states from complete transparency at fully-retracted mode to maximized opacity. Three-dimensional dynamics of devices allows for application of the system in complex building geometries.<sup>3</sup>

The HelioTrace system is adaptable to diverse climatic conditions and geographic locations. The capability of adjusting to individual curtain wall assemblies allows for wide application of system on any building with rational geometry.

Primary components of the system are:

- Exterior kinetic shades
- Prefabricated building envelope

The kinetic shades are responsive to seasonal climatic conditions, daily sun path and operating schedule

relative to building program. Following the daily sun path, kinetics of HelioTrace systems optimize daylighting at interior spaces as well as reducing excessive solar heat gain.<sup>4</sup>

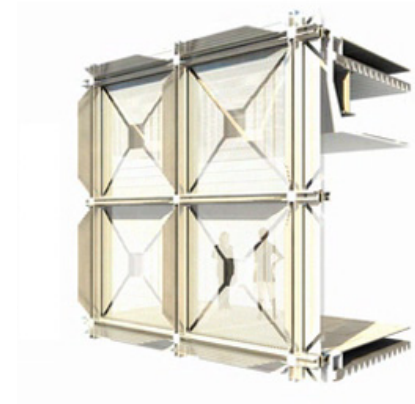
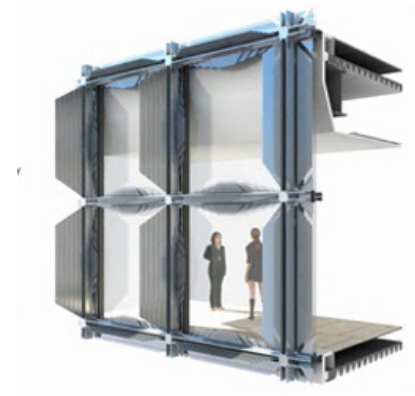

Collateral	
Divergent	✓
Motor-driven	✓
Sensory-driven	
Micro-scale Responsive	
Macro-scale Responsive	✓



## Q1: ThyssenKrupp Quarter

- Location: Essen, Germany
- Project Year: 2010
- Architect: JSWD Architekten + Chaix & Morel et Associés
- Facade Consultants: Priedemann, Berlin und Werner Sobek
- Construction Sunshade Facade: Frener + Reifer, Brixen / Bressanone, Italien

400,000 steel lamellas are utilized in the building's design strategy for sun protection. Real-time adaptation to sun position and provision of unobstructed view to outside are the primary characteristics of the shading in ThyssenKrupp Quarter.<sup>5</sup>

## Homestatic Façade System

(Prototype system)

- Location: New York, NY
- System Designer: Decker Yeadon

Developed prototype of the system consists of organically-shaped artificial muscles responding to dynamic environmental conditions. The system utilizes dielectric elastomer to execute alterations in the shape of shading devices.<sup>6</sup> Depending on the exterior condition, the adjustable squiggles expand or retract to control the solar heat gain at interior spaces. Engineered material property of shading devices allows for self-controlled responses to environmental condition. Overall energy consumption of the system, therefore, is significantly lower than conventional shading systems controlled by computer programming.<sup>7</sup>

Collateral	
Divergent	✓
Motor-driven	
Sensory-driven	✓
Micro-scale Responsive	✓
Macro-scale Responsive	

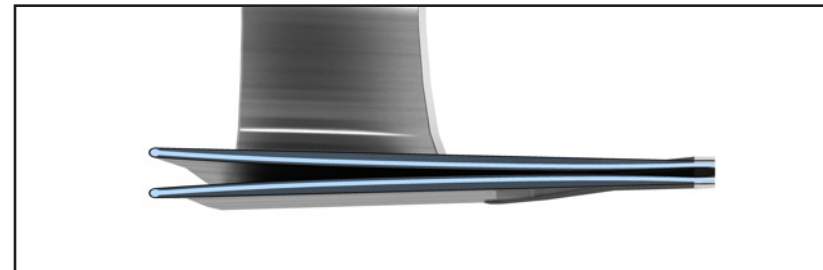
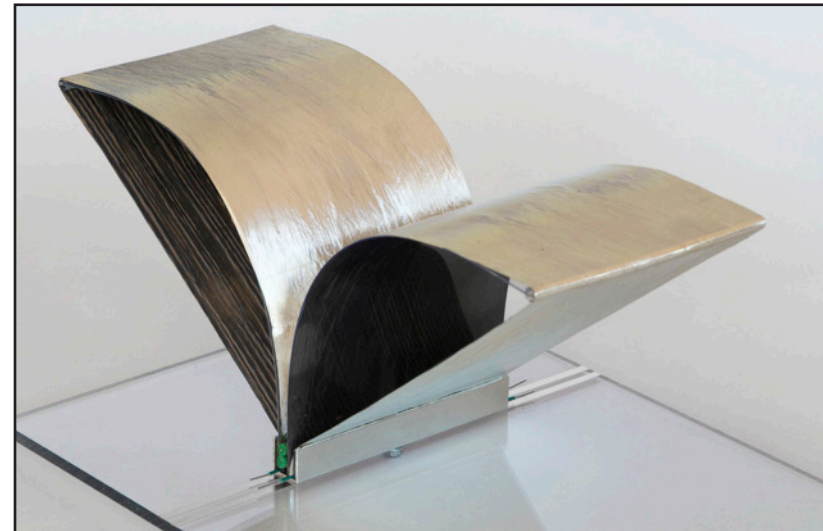

Collateral	
Divergent	✓
Motor-driven	✓
Sensory-driven	
Micro-scale Responsive	
Macro-scale Responsive	✓

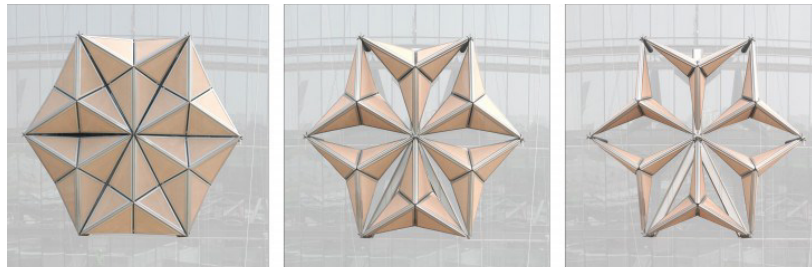

## Al Bahar Towers

- Location: Abu Dhabi, United Arab Emirates
- Project Year: 2012
- Architect: Aedas Architects
- Façade System Designer: Aedas Architects

“The 145 meter towers’ Masharabiya shading system was developed by the computational design team at Aedas. Using a parametric description for the geometry of the actuated facade panels, the team was able to simulate their operation in response to sun exposure and changing incidence angles during the different days of the year.

The screen operates as a curtain wall, sitting two meters outside the buildings’ exterior on an independent frame. Each triangle is coated with fiberglass and programmed to respond to the movement of the sun as a way to reduce solar gain and glare. In the evening, all the screens will close.

At night they will all fold, so they will all close, so you’ll see more of the facade. As the sun rises in the morning in the east, the mashrabiya along the east of the building will all begin to close and as the sun moves round the building, then that whole vertical strip of mashrabiya will move with the sun.

It is estimated that such a screen will reducing solar gain by more than 50 percent, and reduce the building’s need for energy-draining air conditioning.

Plus, the shade's ability to filter the light has allowed the architects to be more selective in glass finishes.

The screen allows for more naturally tinted glass, which lets more light in for better views and less need of artificial light. It's using an old technique in a modern way.”<sup>8</sup>

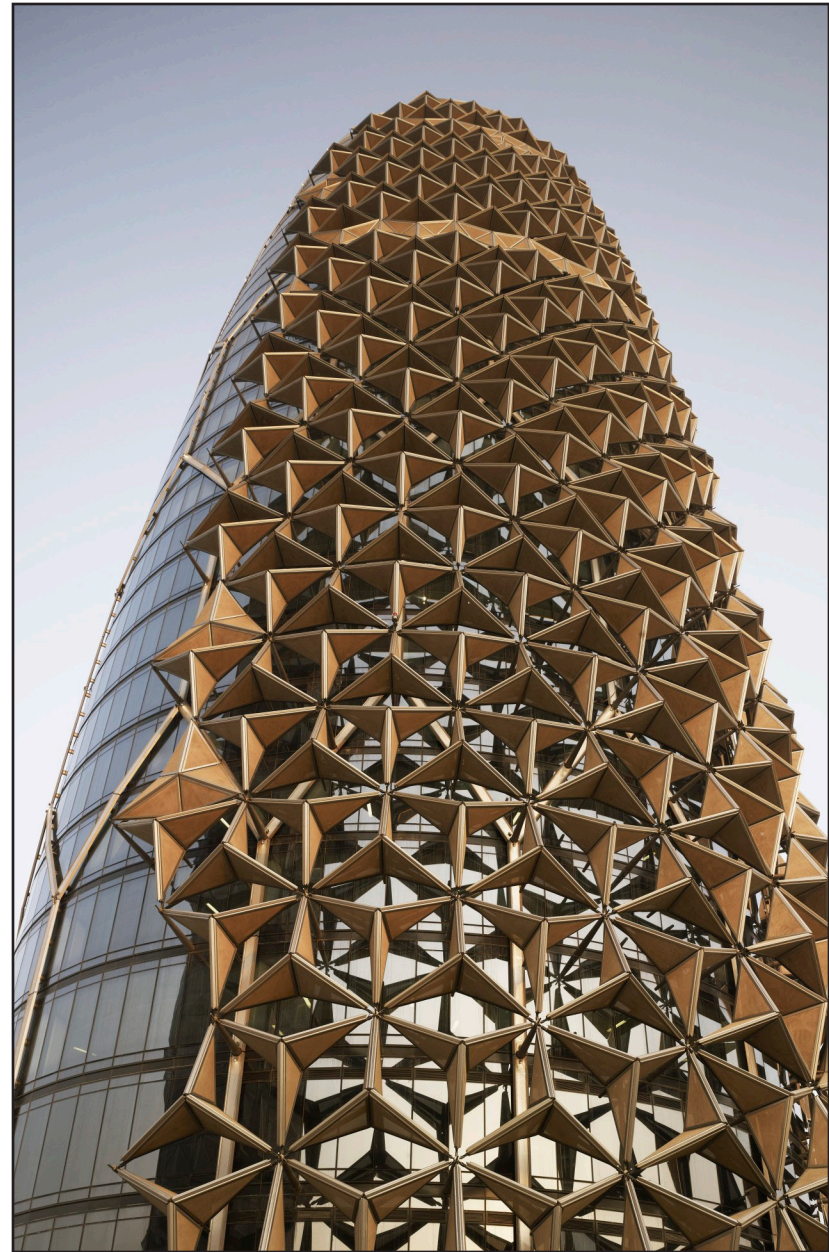

Chapter 3

**Adaptive Shading Systems:  
Deployed Daylight Control Metrics**

## Chapter Contents Summary:

This chapter explores the metrics and evaluation tools of daylight control strategies in precedent adaptive shading systems. The conducted investigation elucidates the primary purposes of using adaptive shading systems by identifying the daylight control metrics and corresponding evaluation tools integrated with the shading systems' functionality. Identified metrics of daylight control strategies are classified in two primary categories: Occupants' Visual Comfort and Energy Consumption Efficiency. Corresponding simulation types and evaluation tools relative to investigated metrics are classified per individual category.

### Occupants' Visual Comfort

Lighting parameters that impact occupant's visual comfort are listed as follows:

- Illuminance (Incident Luminous Flux per unit area)
- Luminance distribution patterns
- Access to the view to outside

**Illuminance (Incident Luminous Flux per unit area):** provision of sufficient illuminance values for execution of target task(s). Excessive or deficient illuminance values relative to the optimal range for the target task(s) must be averted.

**Luminance distribution patterns:** prevention of glare problem within the occupants' view range. Adequate levels of luminance distribution variations are beneficial to create a stimulating luminous environment, but excessive variations are harmful as they cause visual discomfort.

**Access to the view to outside:** availability of visual contact between occupants and the surrounding environment outside. Enhanced view-to-outside is advantageous to occupants for a natural perception of time passage, sense of openness and fluidity in space.

## **Occupants' Visual Comfort: Evaluation Metrics**

Corresponding with elements of occupant's visual comfort in relation with shading systems, precedent metrics for evaluation of lighting conditions are identified:

- Daylight Illuminance Values
  - Daylight Glare Probability (DGP)
  - Shadow-range Studies for Direct Sun Patch Penetration
  - Glare Evaluation Based on Upper Luminance Threshold
  - View Obstruction Ratio
- 
- **Daylight Illuminance:**

Daylight Illuminance represents the total luminous flux incident on a surface, per unit area. The illuminance values are critical to make an analogy between the incident light rays on a target plane and optimal light levels for target task(s).

- **Daylight Glare Probability (DGP):**

Daylight Glare Probability is a precedent glare evaluation method introducing the DGP metric. The DGP metric is “a function of the vertical eye illuminance

Glare Rating	Average DGP
Imperceptible	0.33
Perceptible	0.38
Disturbing	0.42
Intolerable	0.53

Table 3-1: DGP evaluation relative to occupants' visual comfort

as well as on the glare source luminance, its solid angle and its position index”<sup>1</sup>. Areas of occupant’s comfort relative to the DGP values are presented.<sup>2</sup> (Table 3-1)

- **Shadow-range Studies for Direct Sun Patch Penetration**

Shadow-range studies are conducted to evaluate the visual comfort of occupants based on the penetration of direct sun patch within the interior spaces on target surface(s) like the task plane. The obstruction of direct sun patch by shading devices and/or the surrounding building context is verified as the proof for visual comfort and experiencing no glare issues at the viewpoints that are located within the shadow region.

- **Glare Evaluation Based on Upper Luminance Threshold:**

Single luminance value is determined as the threshold to define the “problematic” luminance values within the target viewrange(s). The identified problematic luminance values refer to all luminance values, within the viewrange, equal to and/or greater than the defined threshold. The luminance value of 3000 cd/m<sup>2</sup> is a common threshold utilized in glare evaluations based on an upper threshold.

### ▪ **View Obstruction Ratio**

No predominant evaluation metrics were identified in precedent shading strategies. Therefore, a new evaluation method is suggested as follows:

Three parameters are identified to define a metric for “view to outside” comfort quality:

- Clear Glazing Area
- View Region
- Area of Obstruction

**Clear Glazing Area:** suggested as the area of a glazing region where the transparency of glazing assembly is greater than 50%.

**View Region:** suggested as the area of a region bounded by the intersection of a sitting human field-of view\* and the clear glazing area. Considering the variation of distances between sitting occupants with glazing plane, an average distance value equivalent to 50% of room depth is verified for basic design studies.

**Area of Obstruction:** suggested as the area of a region bounded by the perpendicular projection of shading devices’ geometry, at a given state, to the glazing plane.

\* Sitting Human Vertical Field of View: the 110° vertical angle of view field relative to an average sitting human eye level of 47 inches.<sup>3</sup>

**View Obstruction Ratio:** Based on the definition of suggested parameters, the View Obstruction Ratio is equal to Area of Obstruction divided by the Clear Glazing Area. The value for View Obstruction Ratio falls into a range with minimum value of 0 and maximum value of 1. Lower View Obstruction Ratio corresponds with larger glazing area with available view to outside.

### **Evaluation Tools**

Simulation types are identified based on the target metrics for evaluation of occupants' visual comfort. Parameters associated with individual simulation types are categorized relative to their area of impact. (Table 3-2)

Metric	Simulation Type	Simulation Parameter
Daylight Illuminance	Point-in-time illuminance <ul style="list-style-type: none"> <li>▪ Equinoxes</li> <li>▪ Solstices</li> <li>▪ Target dates</li> </ul>	Sky Condition
		Date & Time
		Sensor Location
		Shading state
		Calculation Grid Height
	Annual illuminance <ul style="list-style-type: none"> <li>▪ Daylight Autonomy</li> <li>▪ Daylight Availability</li> <li>▪ Continuous Daylight Autonomy</li> <li>▪ Useful Daylight Illuminance</li> </ul>	Occupancy Schedule
		Weather Data
		Target illuminance value
		Visual Comfort Adaptation
		Calculation Grid Height
Daylight Glare Probability (DGP)	Point-in-time Glare <ul style="list-style-type: none"> <li>▪ Equinoxes</li> <li>▪ Solstices</li> <li>▪ Target Dates</li> </ul>	Sky Condition
		Date & Time
		Point of View
		Shading state
	Annual Glare	Occupancy Schedule
		Weather Data
		Visual Comfort Adaptation
		Point of view
Shadow-range Studies for Direct Sun Patch Penetration	Time Lapse Visualization <ul style="list-style-type: none"> <li>▪ Equinoxes</li> <li>▪ Solstices</li> <li>▪ Target Dates</li> <li>▪ Monthly/Daily Loops</li> </ul>	Analysis Plane Direction
		Sky Condition
		Date
		Start Hour
		End Hour
		Time Steps
Glare Evaluation Based on Upper Luminance Threshold	Point-in-time HDR & FalseColor Image <ul style="list-style-type: none"> <li>▪ Equinoxes</li> <li>▪ Solstices</li> <li>▪ Target Dates</li> <li>▪ Monthly/Daily Loops</li> </ul>	Sky Condition
		Date & Time
		Point of View
		Shading state
		Upper threshold of luminance values
View Obstruction Ratio	Point-in-time Obstruction: <ul style="list-style-type: none"> <li>▪ Parametric Calculation Script</li> <li>▪ Manual Calculation</li> </ul>	Clear Glazing Area
		View Region
		Area of Obstruction

Table 3-2:  
Simulation types with corresponding parameters as evaluation tools for identified metrics of occupants' visual comfort

## **Energy Consumption Efficiency**

The impact of adaptive shading systems' performance on the cumulative energy consumption in a building is categorized as:

- Reduction in use of electric lighting
- Optimization of solar heat gain

### **Reduction in use of electric lighting:**

The optimization of daylight penetration to the interior spaces reduces the demand for electric lighting to compensate low light levels.

### **Optimization of solar heat gain:**

Adaptive shading systems can control the level of direct solar heat gain inside the space in relation with the HVAC system's mode. Based on the demand for cooling or heating at the interiors, the shading system increases solar heat gain at the heating mode and decreases it at the cooling mode. Consequently, less energy is consumed to generate certain heating or cooling loads.

## **Energy Consumption Efficiency: Evaluation Metric**

The evaluation metric integrated with the precedent adaptive shading system's performance relative to energy consumption efficiency is identified:

- Cumulative Energy Consumption Loads

### **Cumulative Energy Consumption Loads:**

Represents the overall energy consumption loads at specified time intervals (hourly, monthly) on an annual basis. Four individual categories of Heating, Cooling, Lighting and Equipment are identified in relation with energy consumption loads.

### **Evaluation Tools**

Simulation types are identified based on the target metric for evaluations of energy consumption efficiency. Parameters associated with individual simulation types are categorized relative to their area of impact. (Table 3-3)

Table 3-3:  
Simulation types identified  
as evaluation tools for  
metrics of energy  
consumption efficiency

Metric	Simulation Type	Simulation Parameter	
Cumulative Energy Consumption Loads	Thermal Analysis	<b>Climate-based Simulation</b> parameters	Occupancy Schedule
			Weather Data
			Target Illuminance Value
			Visual Comfort Adaptation
			Sensor Locations
		<b>Thermal &amp; Conditioning Systems</b> parameters	Occupant Density
			Equipment Power Density
			Air Changes Per Hour
			Heating Efficiency
			Cooling Efficiency
			Cooling Setpoint
			Cooling Setback
			Heating Setpoint
			Heating Setback
Natural Ventilation			



Chapter 4  
**Building Program & Site Analysis**

## **Chapter Contents Summary:**

Digital parametric modeling and simulation platforms utilized for development of the study model are introduced. The introduced modeling and simulation platforms are as well deployed in the investigation process and design development of a new glare control method and adaptive shading system. The method of investigation to develop a digital study model for simulation, as well as the selected project site and corresponding site analysis associated with simulation assumptions are described.

## **Form Generation & Analysis Tools:**

- **Application of Digital Parametric Modeling and Simulation Platforms**

Described complexities of daylight control strategies in high-rise office buildings and association of several parameters with individual analysis necessitates the use of parametric modeling and simulation platforms for development of a new glare control method and adaptive shading system. Such form generation and analysis tools are utilized to evaluate various aspects of a study model for simulation purposes and determine sets of values for individual metrics associated with the development of the study model. The application of these platforms, however, is not limited to design investigations related to development of a study model. The use of parametric modeling and

Platform	Primary Utilization Purpose
Rhinoceros	3D Modeling
Diva for Rhinoceros	Daylighting Simulation
Ecotect Analysis	Environmental Analysis
wxfalsecolor	HDR & FalseColor Image Processing
3D Studio Max (Using V-ray Plugin)	3D Model Rendering

Table 4-1: Digital non-parametric platforms

Platform	Primary Utilization Purpose
Grasshopper	Parametric 3D Modeling Algorithm Development & Data Analysis
Diva for Grasshopper	Parametric Daylight Simulation

Table 4-2: Digital parametric platforms

simulation platforms is especially critical once integrating multiple sets of data such as simulation results for distributed luminance values relative to several viewpoints with the mathematical functions utilized for specific data analysis algorithms and the developed geometric expressions regulating several dimensions of the study model. Deployed digital parametric modeling and simulation platforms are presented. (Tables 4-1 & 4-2)

### **Building Program: The Specifications of a Study Model for Simulation**

The building program introduces various criteria of an ideal study model for simulation. An ideal study model should be applicable to several simulation conditions and capable of incorporating the variation of data for every set of parameters. This section of the thesis explores the process of defining the metrics of a study model. The sequence of explorations executed is as follows:

- i. Identification of all the affective parameters to simulate various daylight distribution conditions
- ii. Investigating the domain within which applicable values per individual parameter fall into

- iii. Verification of parameter values determined as constant in simulation assumptions
- iv. Development of a study model for simulation associating all the investigated parameters

### **Study Model Parameters:**

Affective parameters incorporated with the study model for diverse simulation conditions are identified:

- Office Use Physical Program
- Building Mass Form
- Room Depth
- Floor-to-Ceiling Height
- Occupancy Schedule
- Furniture Layout

### **Method of Investigation**

#### **• Office Use Physical Program:**

Elements of physical program for office use are investigated. The associated elements are selected based on individual activity types and their priorities for controlled daylight access. Consequently, all the program elements relative to activities with marginal priorities for controlled daylight access are excluded from the study model. Selected activity types with controlled daylight access are listed:

- Shared Office Spaces
- Grand Conference Room
- Intimate Conference/AV Rooms
- Lounge Areas

- **Building Mass Form:**

The following criteria are determined for study model's form:

- Capable of best representing data alteration for daylight distributing patterns subordinate to variations in orientation and daily sun path
- Necessitates formal adaptability of shading devices to address non-flat glazing surfaces

Considering the identified criteria, the study model's form is determined according to the specified floor plates' outline and regulated vertical juxtaposition:

**Floor Plate Outline:** an elliptical outline for the floor plates of the study model is selected. The elliptical form, in contrast with geometrical figures with straight side(s), allows for tracking the path of the sun along the floor plate's outline as well as its effect on the interior daylight distribution and consequent shading patterns. Furthermore, the elliptical form, in comparison with a circular form, presents variable distances between the perimeter and the center. Such variation is critical to incorporate the range of values identified for the room depth parameter. (Figure 4-1)

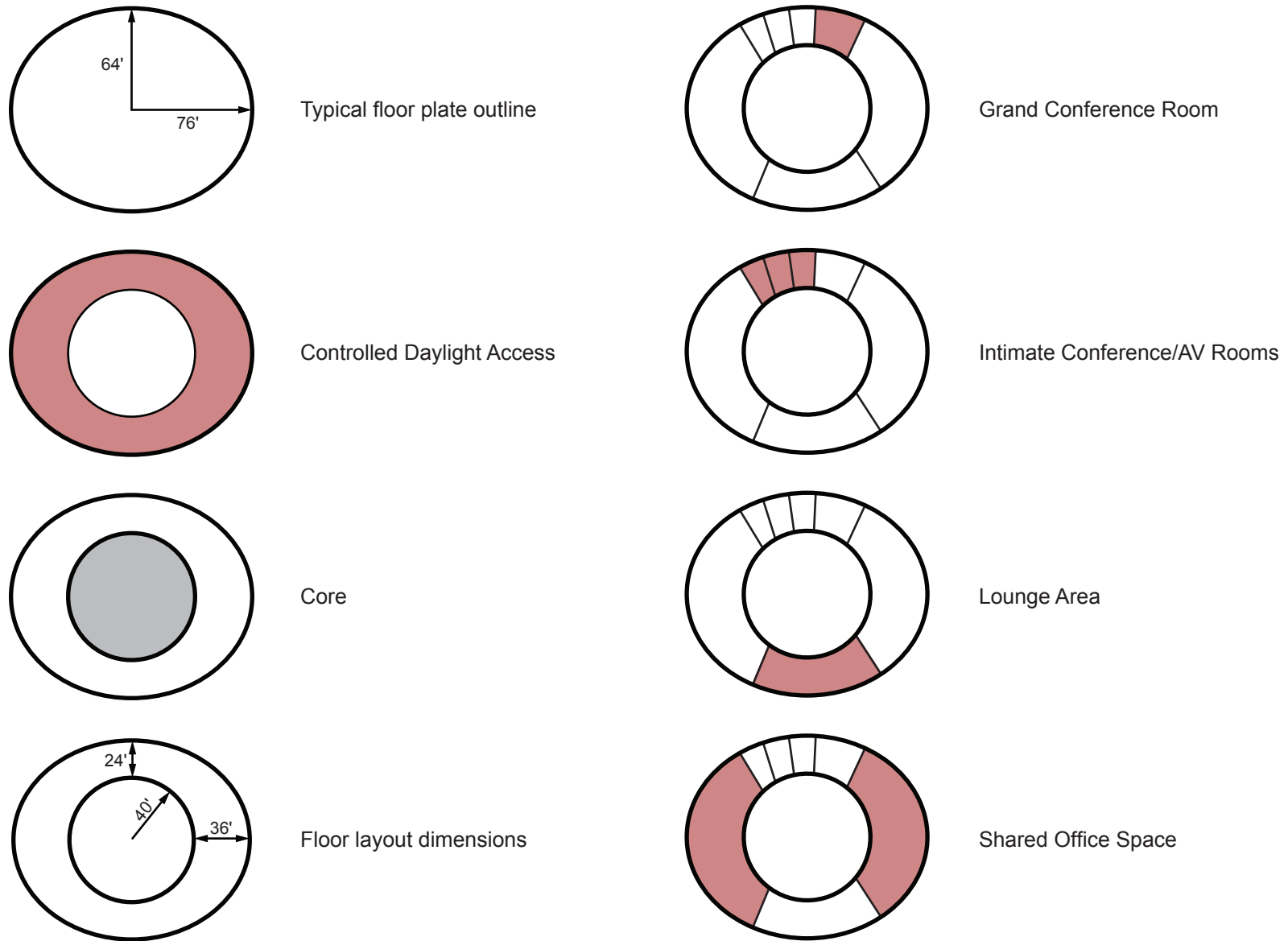

Figure 4-1: Floor plate outlines

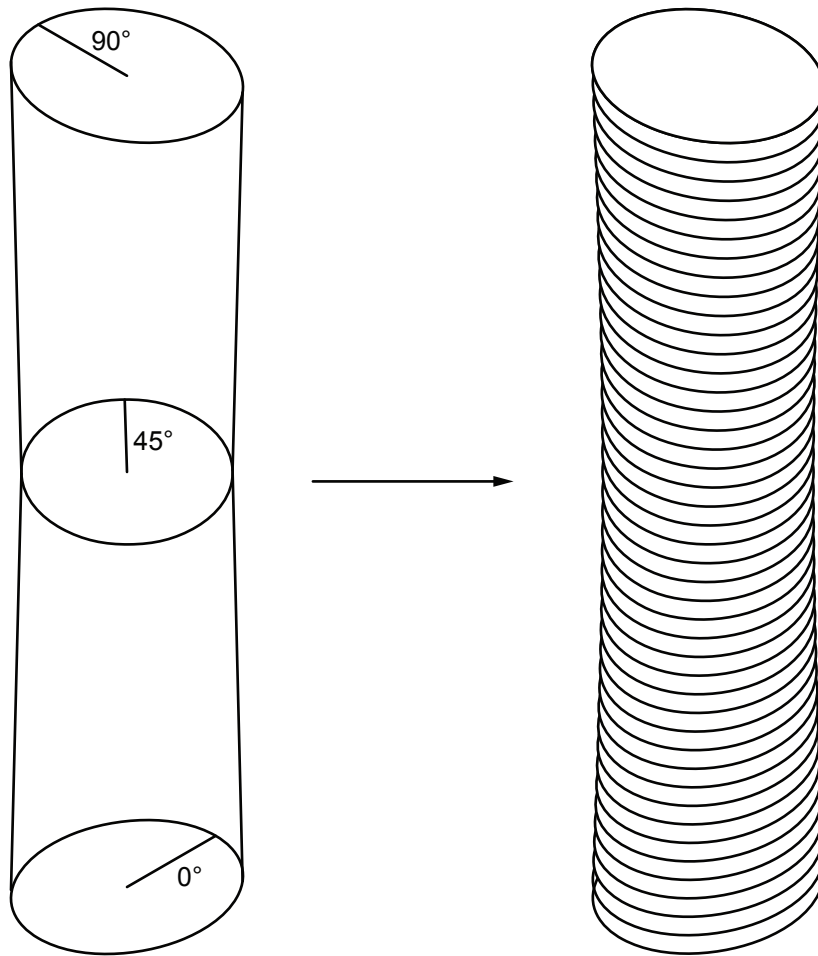

Figure 4-2: 90° rotation of floor plates along the elevation

**Vertical Juxtaposition of Floor Plates:** The floor plates are stacked around a cylindrical core. Applying a total 90° rotation factor, the position of individual floor plates are altered relative to the preceding ones along the elevation. The applied rotation factor incorporates variations in the orientation of floor plates relative to the cardinal directions. Such variation is critical to examine the daylight distribution patterns for a typical floor layout at different orientations. (Figure 4-2)

- **Room Depth:**

A range of values with minimum value of 12 ft. and maximum value of 48 ft. with intervals of 4 ft. between every two consecutive values is studied to explore the impact of room depth in total illuminance levels inside an interior space (Appendix A). According to simulation results, maximum and minimum values of 36 feet and 24 feet, respectively, are determined to define the layout of floor plates in the study model.

- **Floor-to-Ceiling Height:**

The floor-to-ceiling height is considered as constant at all levels in the study model. The window height at all levels is equal to the floor-to-ceiling height. A range of values with minimum value of 10 ft. and maximum value of 20 ft. with intervals of 2 ft. between every two consecutive values is examined to study the impact of floor-to-ceiling height on daylight distribution within interior spaces (Appendix B). According to simulation results, a constant value of 14 ft. is determined for the floor-to-ceiling height parameter in the study model.

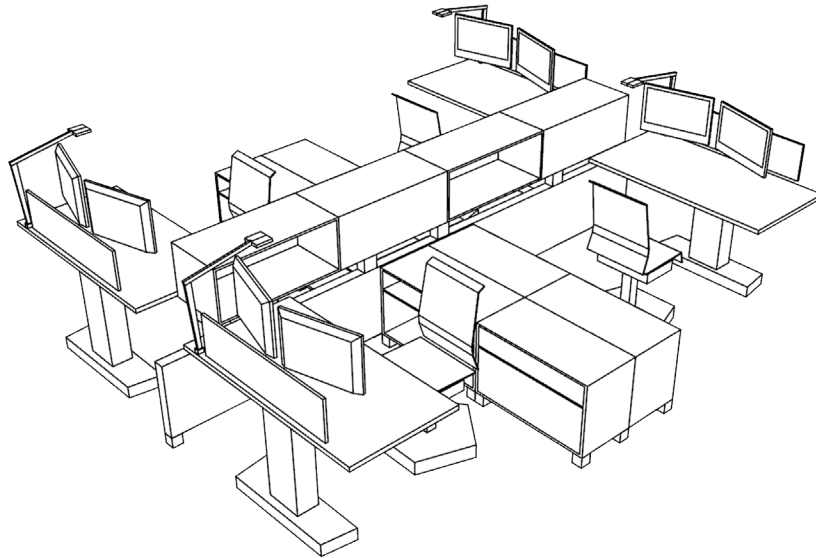

- **Occupancy Schedule:**

The occupancy schedule of 8:00 AM to 6:00 PM for a typical office use (with daylight saving times) is determined for simulation assumptions.

- **Furniture Layout:**

Critical metrics of office furniture units affective to the daylight distribution pattern per individuals' viewpoint at interior spaces are subcategorized as follows:

- Task Plane Height
- Partition Panel Height
- Sitting Height

Office furniture units are selected among available manufactured products in the market\* to simulate the furniture units' configuration relevant to individual activity types at the interior spaces. (Figure 4-3)

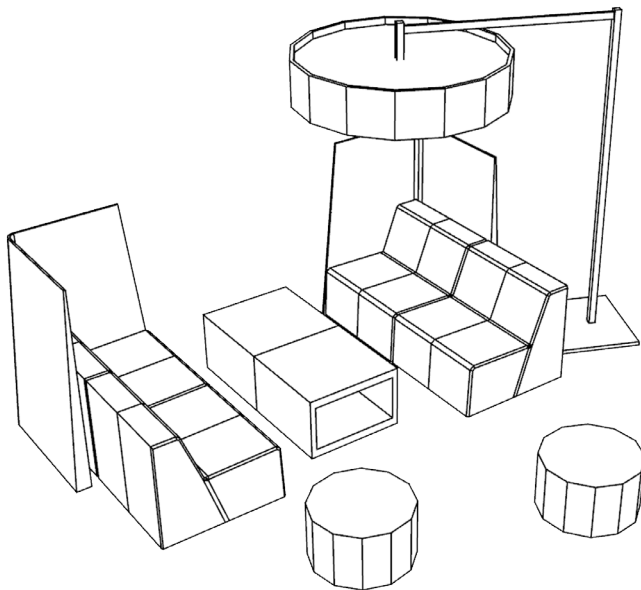

Figure 4-3

Top: Workstation unit at shared office spaces

Down: Furniture units at lounge areas

\* All furniture units are selected from © Steelcase products<sup>1</sup>

Figure 4-4:  
Right: Intimate Conference/AV Room Unit  
Down: Grand Conference Room Unit

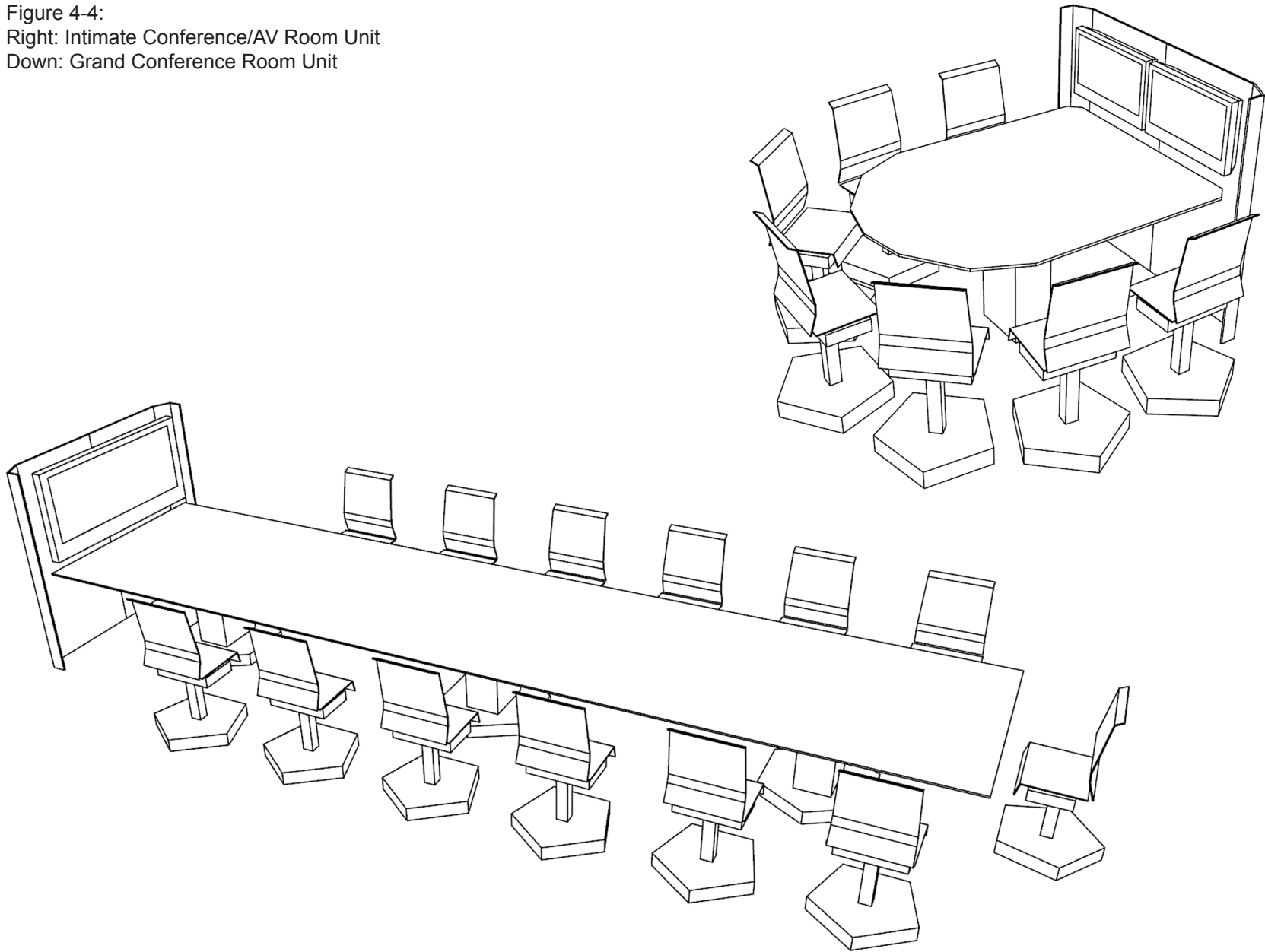

Typical Floor Layout

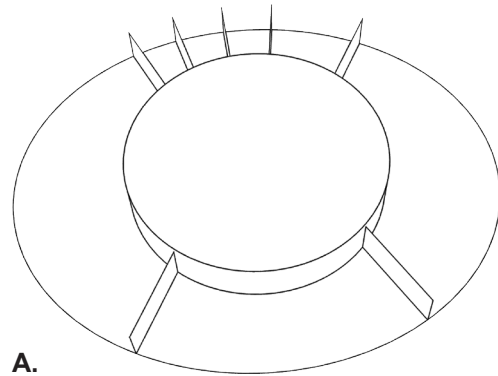

A.

Grand Conference Room

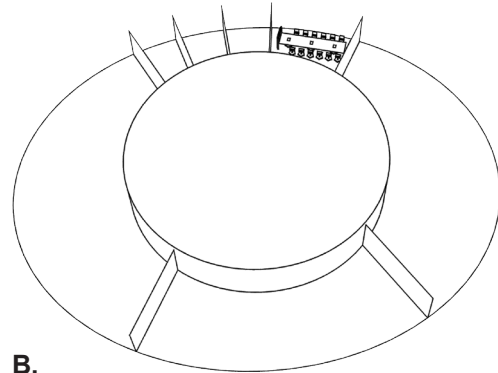

B.

Intimate Conference/AV Rooms

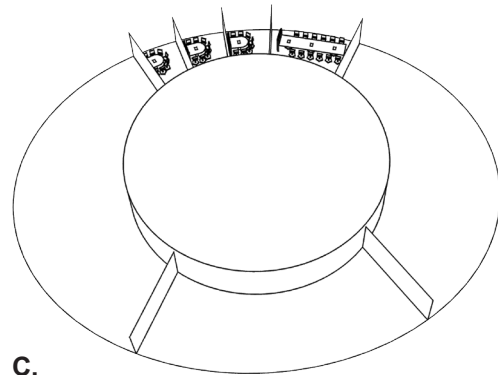

C.

Lounge Area

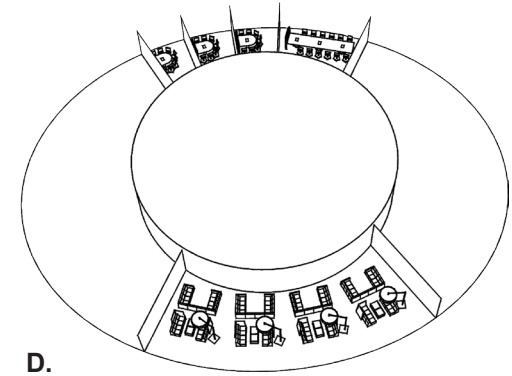

D.

Shared Office Space

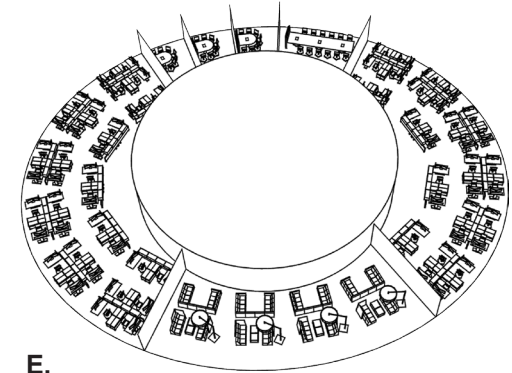

E.

Full Furniture Layout

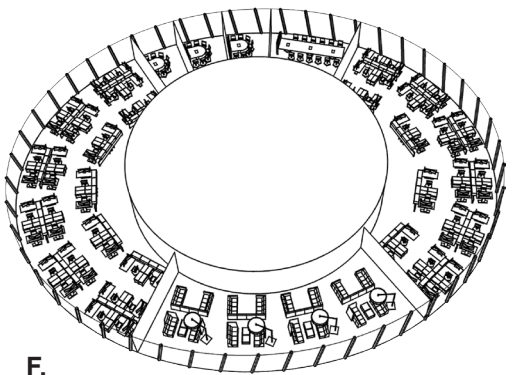

F.

Figure 4-5: Typical floor plan layout out for office use

## Site Analysis

The building site exemplifies the contextual dynamics that affect daylight distribution and control strategies at interior spaces. The variation of these dynamics is subordinate to primary site characteristics identified as:

- Geographic Coordinates
- Climatic Condition
- Physical Context

**Geographic Coordinates:** The geographic coordinates of an individual site defined by latitude and longitude angles corresponds with a sun path diagram representing the position of sun in the sky on an annual basis.

**Climatic Condition:** variable metrics relative to climatic conditions of an individual site signify the environmental dynamics that affect daylight distribution at interior spaces.

**Physical Context:** individual urban contexts exemplify properties affecting lighting conditions at interior spaces. These properties include:

- Building mass adjacencies
- Topography
- Urban blocks' orientation

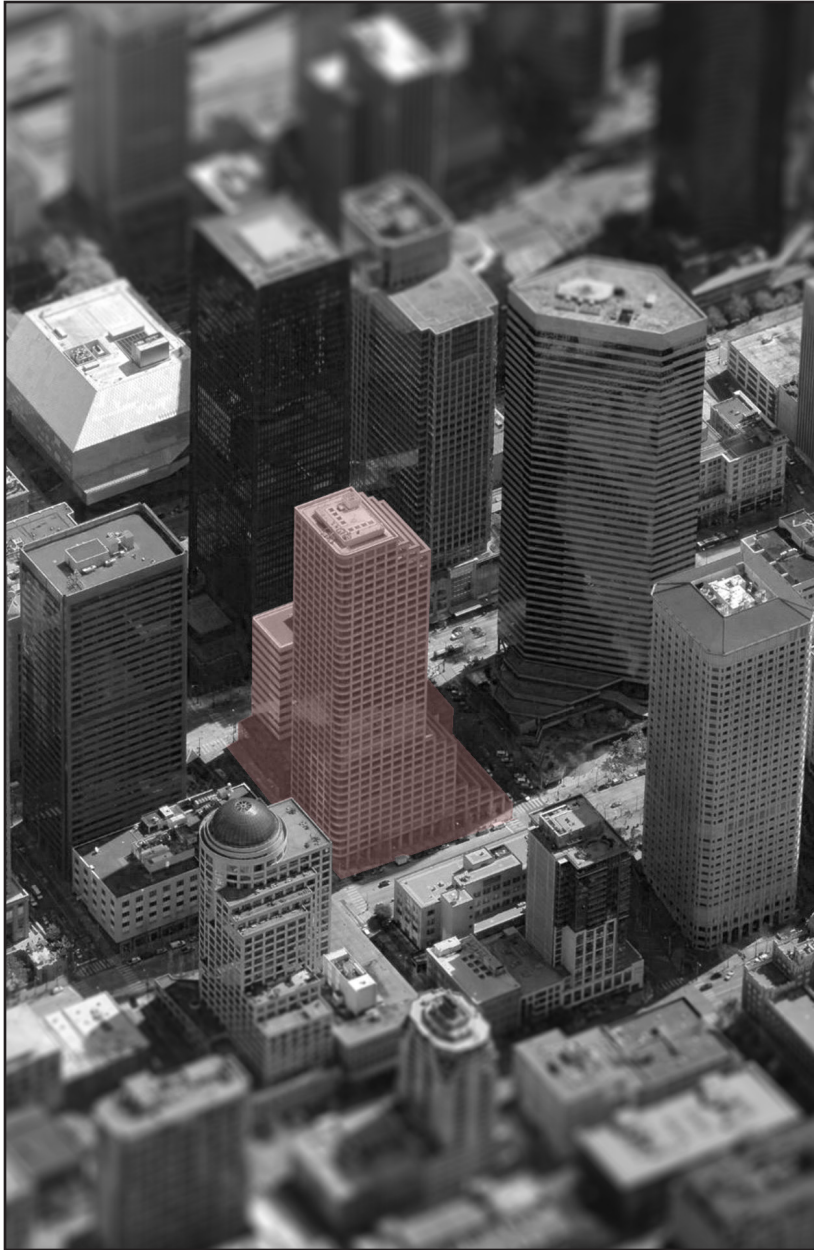

**Project site:** corresponding with target building type verified as high-rise office use, the Downtown Seattle is selected as the site context. The specifications of the urban block selected as the project site are as follows:

- Latitude: 47°36'20.64"N
- Longitude: 122°20'7.58"W
- State: Washington
- City: Seattle
- Urban Block:
  - North-East: 3rd Avenue
  - North-West: Spring Street
  - South-West: 2nd Avenue
  - South-East: Madison Street

Figure 4-6: Existing buildings (highlighted) at project site



Figure 4-7: Project site at Downtown Seattle

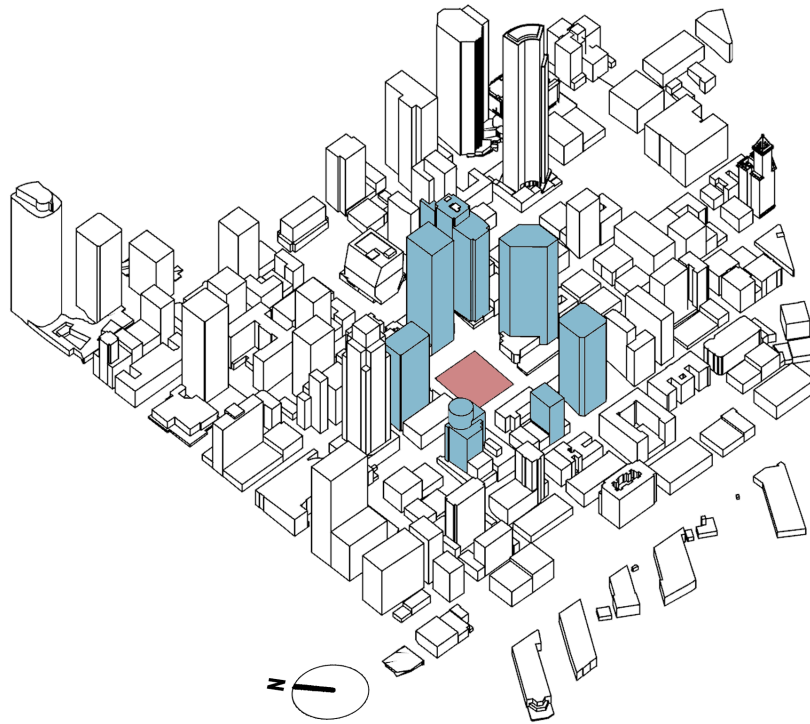

Digital 3D models of Downtown Seattle area including building masses, urban blocks' layout and topography are generated. (Figure 4-8)

**Location of Building Mass at Project Site:** Primary analysis points are selected at four cardinal directions along the site perimeter as well as at the geometrical center of the site to study the annual overshadowing patterns in relation with occupancy schedule. The analysis results suggest that northern and eastern points offer less overshadowing during occupancy time across the year. As a result, the north-eastern side is prioritized for locating the study model. (Figure 4-9)

Figure 4-8: Mid-rise/high-rise site adjacencies in Downtown Seattle

Figure 4-9: Sunpath diagram and overshadowing condition relative to investigated points at site. Highlighted areas represent time intervals with no overshadowing condition relative to target occupancy schedule (8 AM to 6 PM). Increased highlighted areas at Northern and Eastern sides correspond with less overshadowing and greater solar exposure during occupation time.

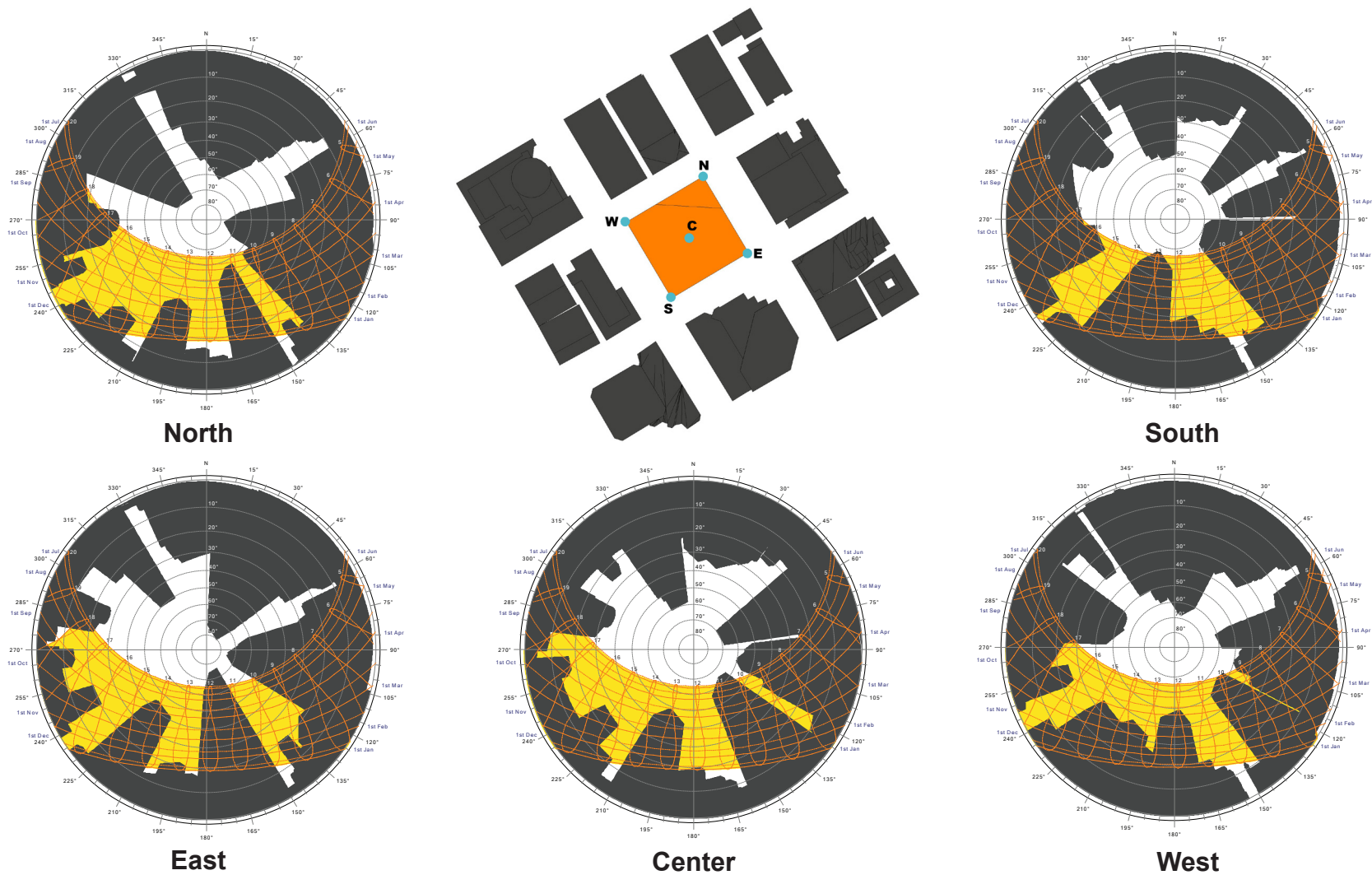

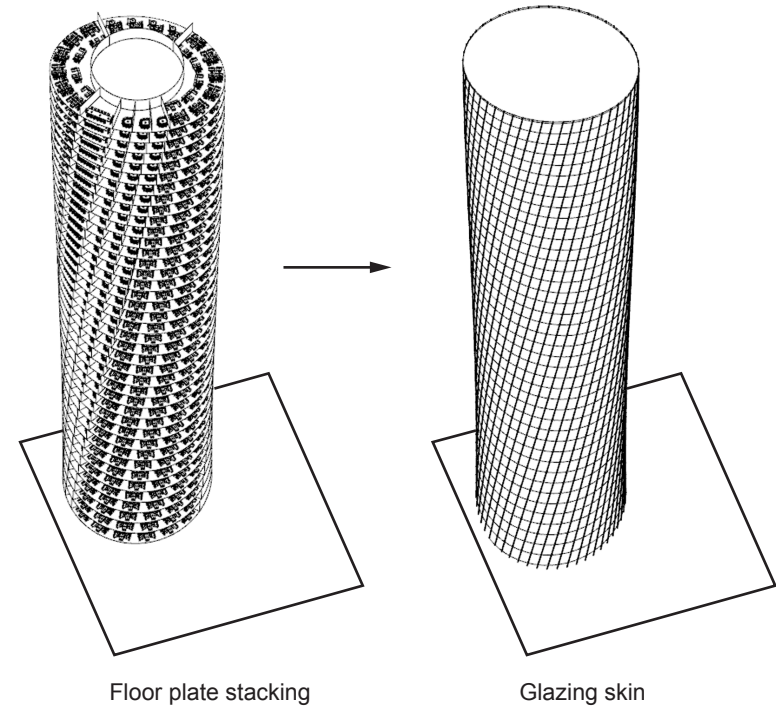
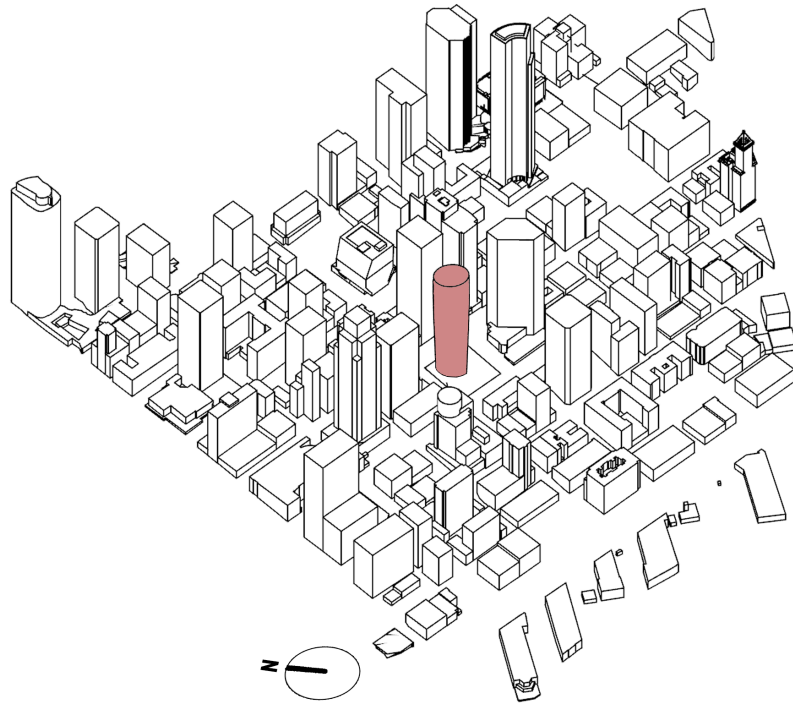

Figure 4-10:  
Top: Building at the site context  
Right: Vertical juxtaposition of floor plates & the applied glazing skin



Chapter 5  
**The GlareShade Method**

## Chapter Contents Summary:

This chapter explores the investigation process of developing a new glare control method entitled the “GlareShade”. The design process of a new adaptive shading system capable of executing generated responses by the GlareShade method is subsequently described.

### The GlareShade Method:

The investigation process of developing the GlareShade method is described sequentially in five steps:

1) Hemispherical fisheye lens is used to generate a single luminance distribution image relative to a view point at a single point in time. Produced luminance distribution image will present a map of all luminance values within a viewrange of  $180^{\circ} \times 180^{\circ}$  at the target point of view. (Figure 5-1)

2) Single falsecolor image corresponding with produced luminance distribution image is generated. (Figure 5-2)

3) The distributed luminance values presented via the falsecolor image are classified into 16 individual contour bands representing a domain of luminance values with a minimum of  $0 \text{ cd/m}^2$  and a maximum of  $3200 \text{ cd/m}^2$  and increments of  $200 \text{ cd/m}^2$  between

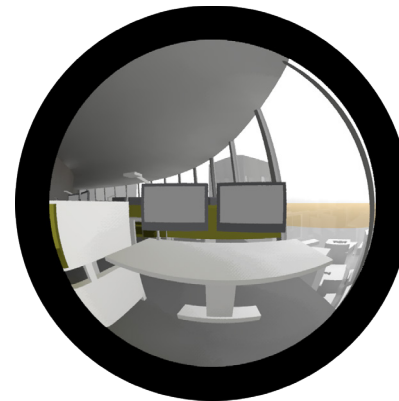

Figure 5-1: Point-in-time Luminance Distribution Image  
March 21st - Clear Sky with Sun  
11:00 AM

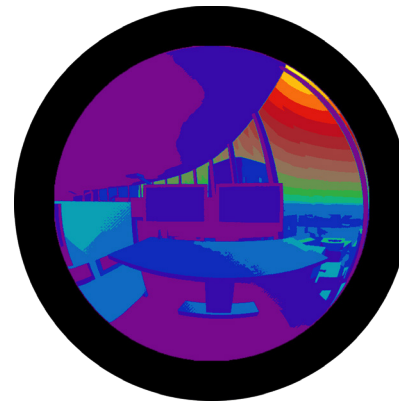
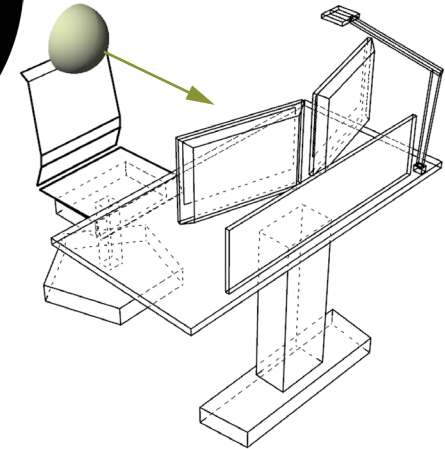
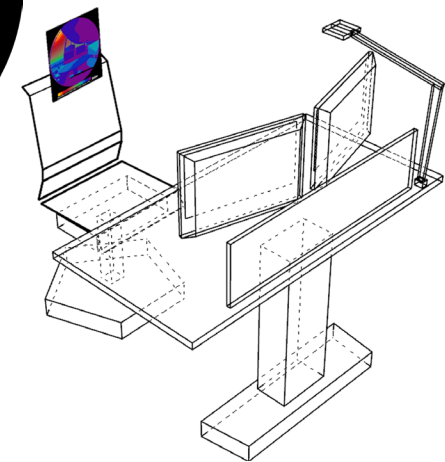

Figure 5-2: Point-in-time FalseColor Image  
March 21st - Clear Sky with Sun  
11:00 AM



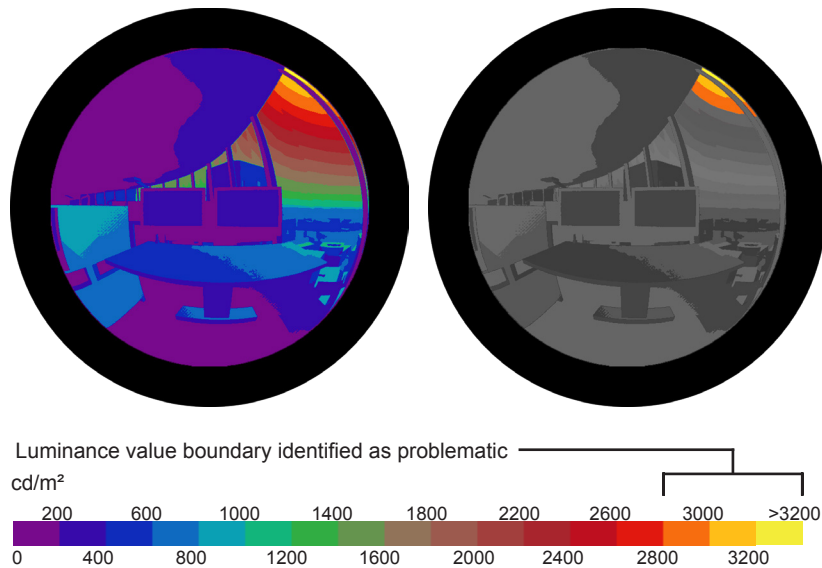

Figure 5-3: Identification of glare region within the viewrange with problematic luminance values

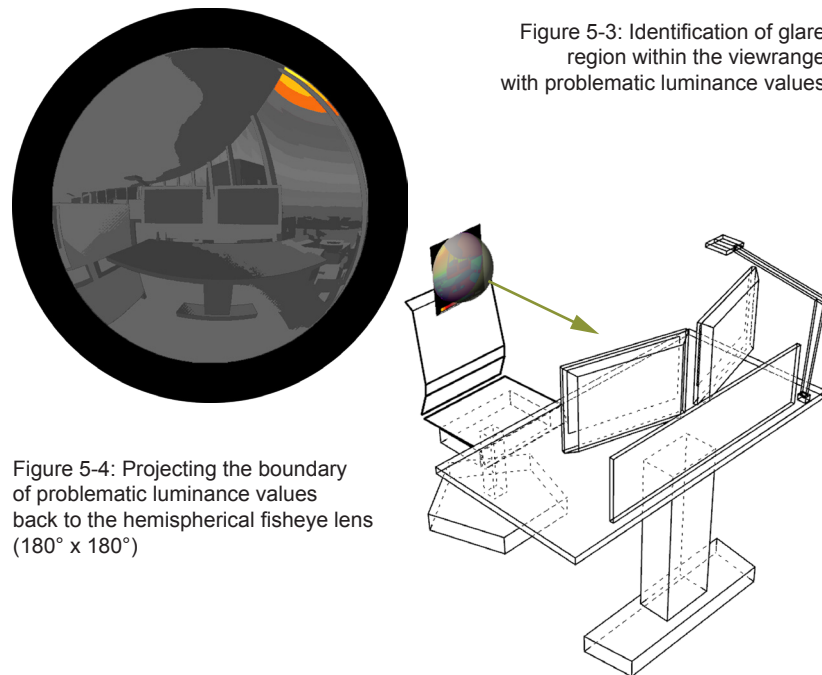

Figure 5-4: Projecting the boundary of problematic luminance values back to the hemispherical fisheye lens (180° x 180°)

every two consecutive contour bands. Identifying the threshold to verify problematic luminance values causing glare issue as 3000 cd/m<sup>2</sup>, contour bands corresponding with luminance values equal to and/or greater than 3000 cd/m<sup>2</sup> are recognized as “problematic” causing the glare issue. Additionally, a marginal zone of luminance values relative to the 200 cd/m<sup>2</sup> increments between consecutive contour bands is selected for inclusion in the “problematic contour bands” set. Therefore, the contour bands with a domain of luminance values equal to and/or greater than 2800 cd/m<sup>2</sup> is recognized as problematic. (Figure 5-3)

4) Identified geometric boundary of contour bands with problematic luminance values is projected back to the surface of corresponding fisheye lens’s hemisphere. (Figure 5-4)

5) The consequent geometry on the surface of fisheye lens’s hemisphere is projected back into the space along normal vectors (relative to the hemisphere’s surface) at individual points on its perimeter. The result of the described process is a geometry named as “GlareFunnel”. The GlareFunnel segregates a portion of the space through which, all luminance values cause a glare problem at the corresponding point of view and point in time. (Figures 5-5, 5-6, 5-7)

Thus, any configuration of intersecting geometries with the GlareFunnel resulting a full obstruction of the funnel's geometry will disrupt the problematic luminance values to cause glare problem at the target point of view and point in time. Such intersection generates a profile of the original GlareFunnel named as "GlareProfile". Thus, any configuration of a set of shading surfaces masking the GlareProfile will result in addressing the glare problem at the target point of view and point in time. (Figures 5-8, 5-9, 5-10, 5-11)

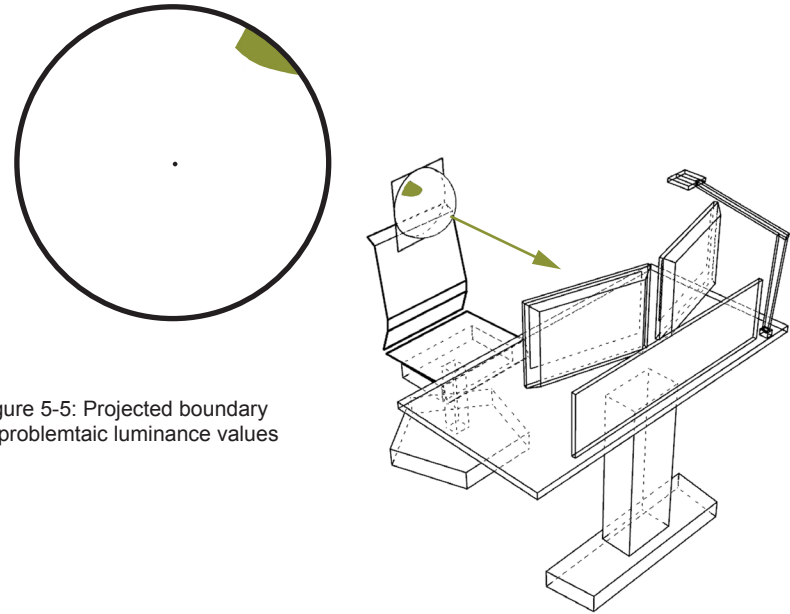

Figure 5-5: Projected boundary of problematic luminance values

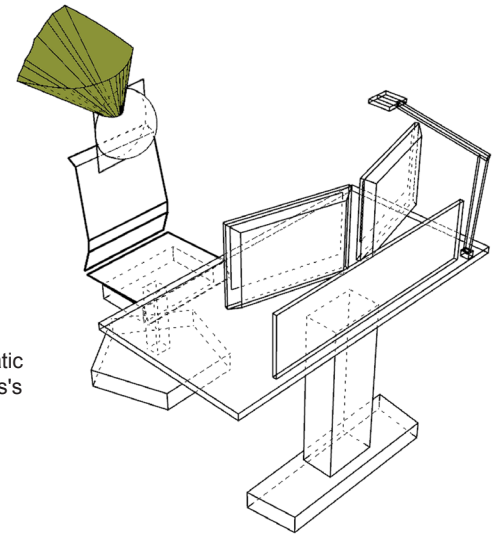

Figure 5-6: GlareFunnel generated relative to the problematic boundary projected on fisheye lens's hemisphere

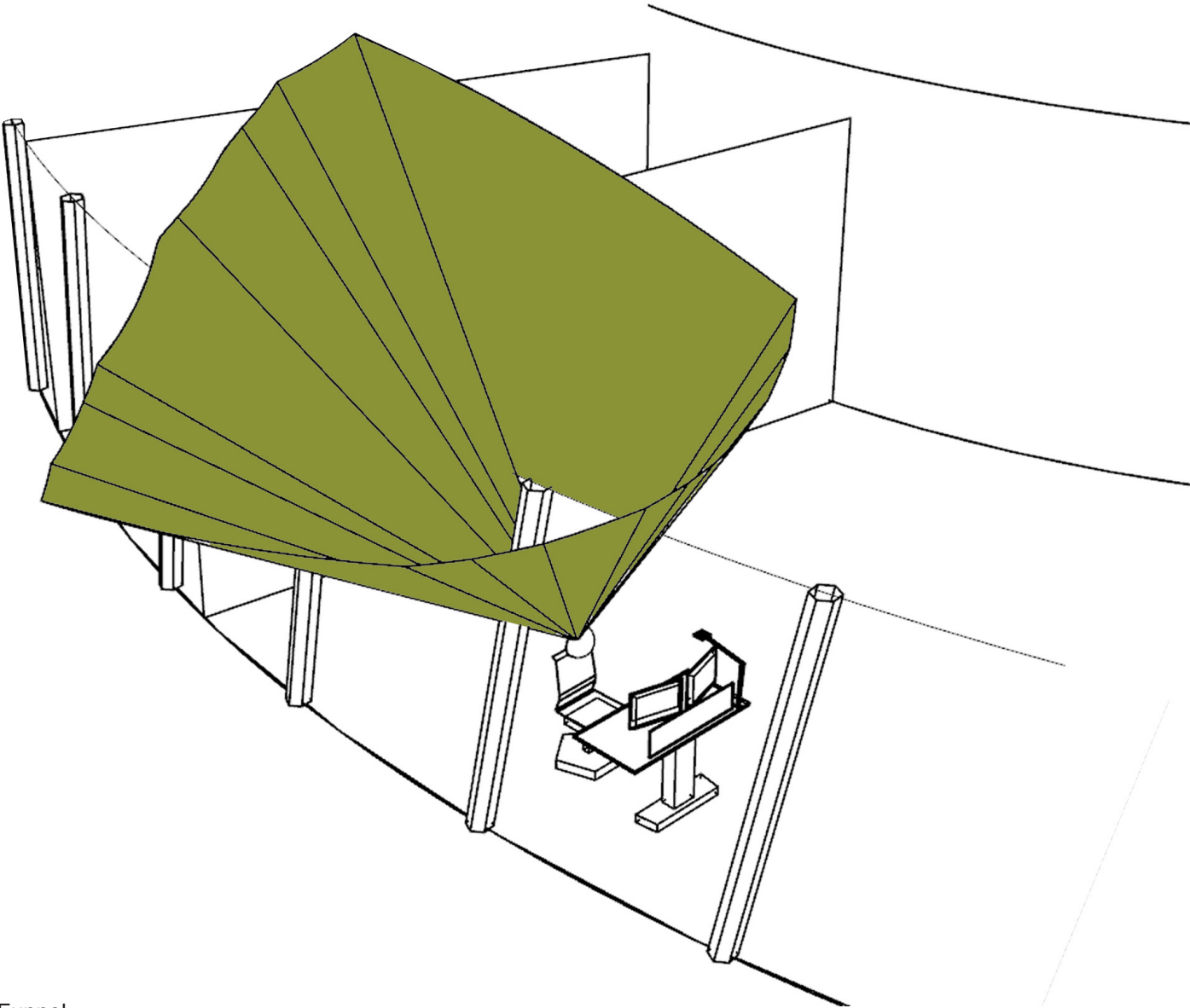
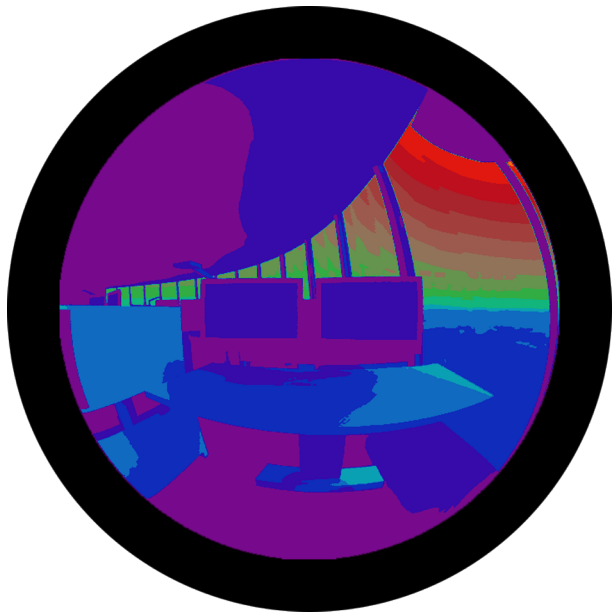
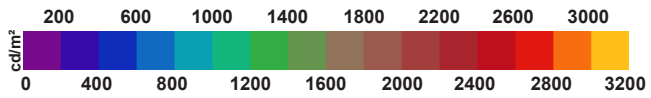

Figure 5-7: The GlareFunnel



FalseColor image with shaded glare profile



Overhang GlareShade profile

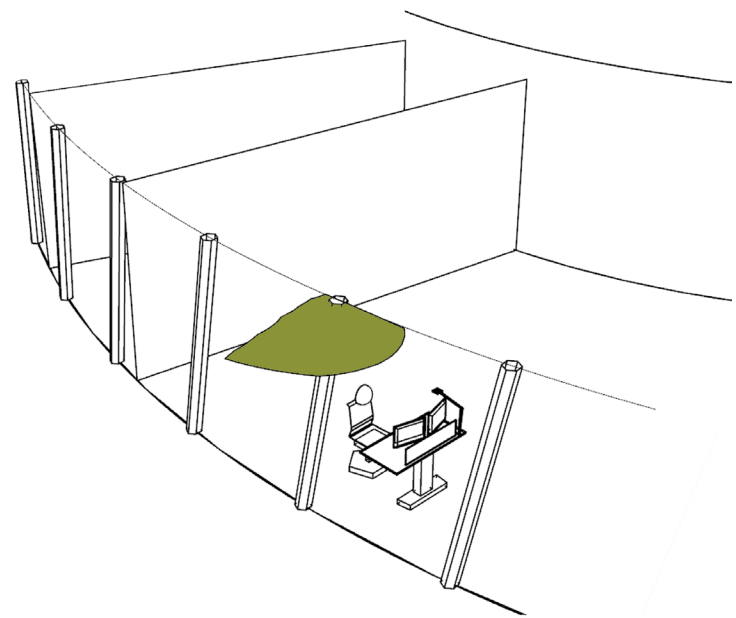
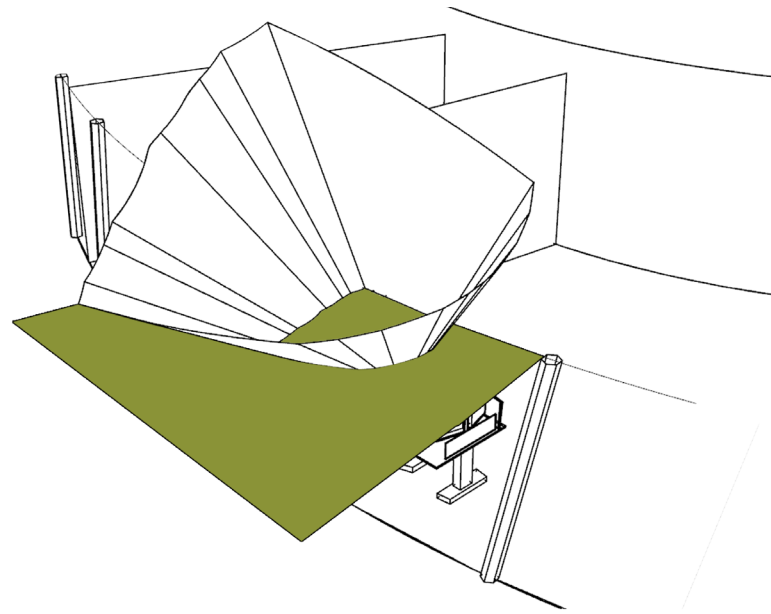
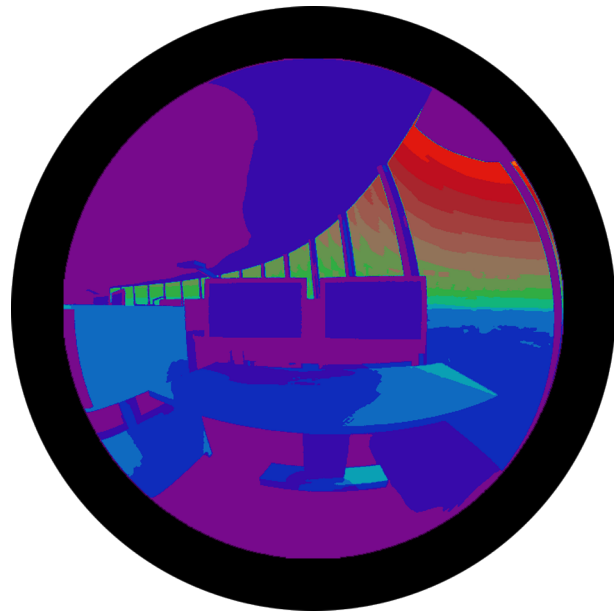
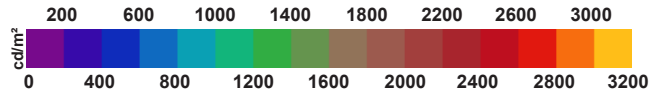

Figure 5-8: GlareFunnel intersection with a horizontal plane at ceiling height.



FalseColor image with shaded glare profile



**GlareShade profile  
coplanar with glazing surface**

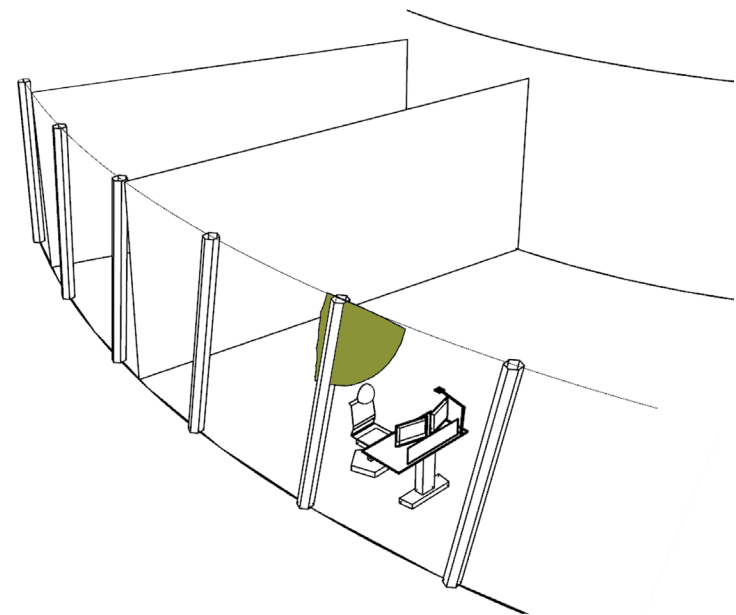
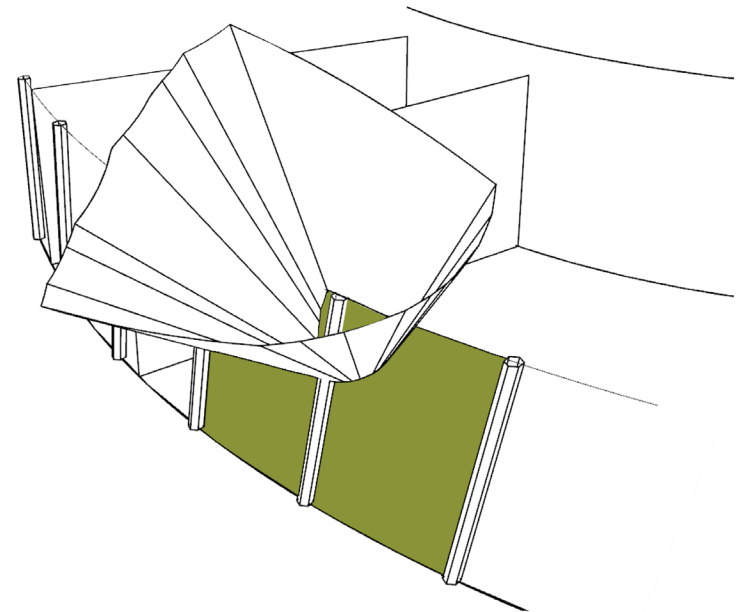
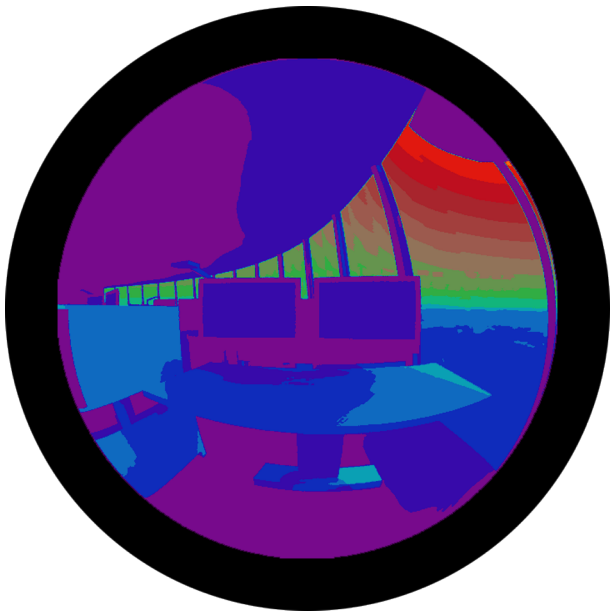
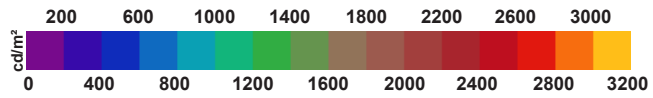

Figure 5-9: GlareFunnel intersection with glazing surface



FalseColor image with shaded glare profile



Non-planar GlareShade Profile

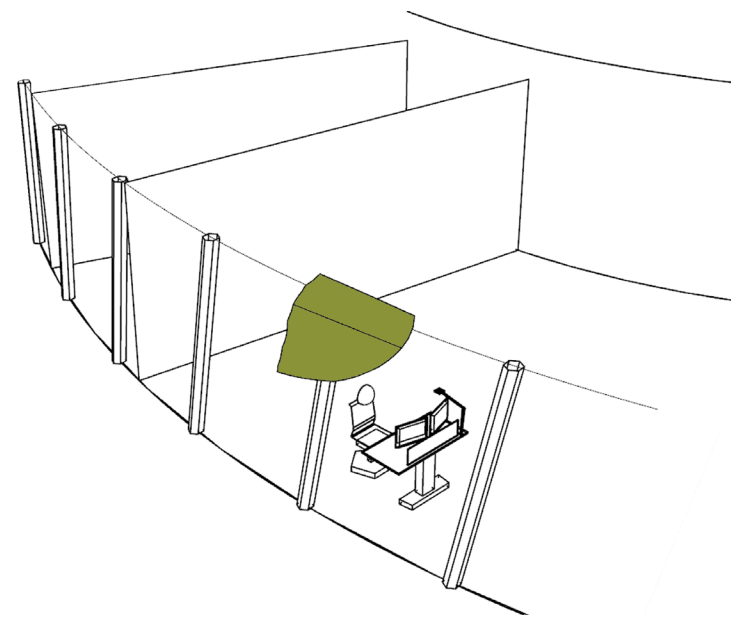
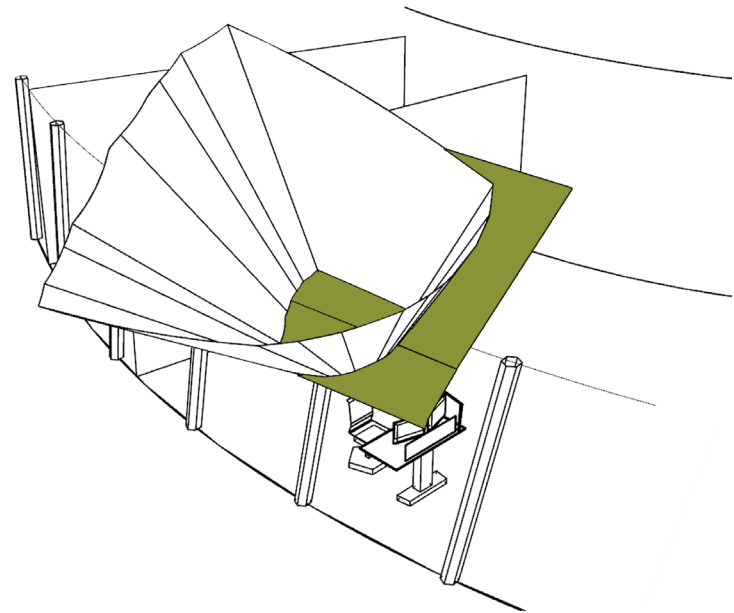

Figure 5-10: GlareFunnel intersection with a non-planar geometry

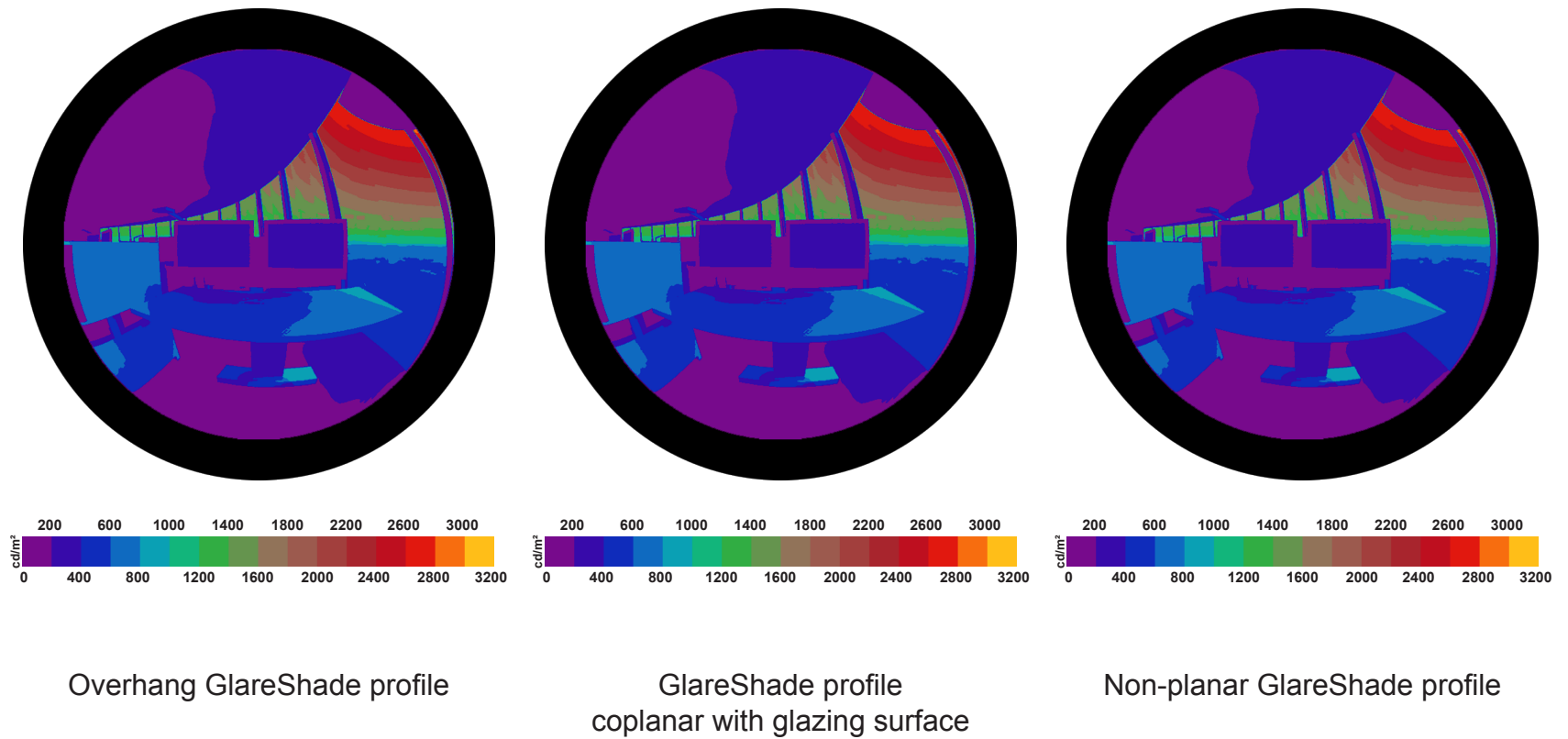

Figure 5-11: any configuration of a set of shading surfaces masking the GlareProfile will result in addressing the glare problem at the target point of view and point in time.

## **GlareShade method & development of an adaptive shading systems**

A variety of shading schemes corresponding with a given set of glareprofiles can be developed. A single shading scheme is a set of shading surfaces masking the glareprofiles and addressing the glare issue at a single point in time for all the investigated points of view. Such flexibility for developing a variety of shading schemes signifies the distinction between GlareShade as a method and the shading system as the medium to execute a shading scheme according to the regulated glareprofiles at a point in time. The distinguishment between the GlareShade as a method and shading system(s) as the medium is critical considering a shading system that is developed to address the glare problem must perform in coordination with other environmental control systems and be integrated with the construction assemblies developed through the design of a building. For example, the integration of a shading system developed to address the glare issue with the curtain wall system used as part of the entire building façade demands a high level of coordination and adjustments for the shading system before it can be installed as part of the façade assembly and perform as part of the building's environmental control strategy. Therefore, the GlareShade method's capability to suggest a variety of glareprofile sets (depending on the type of geometrical intersections with glarefunnels)

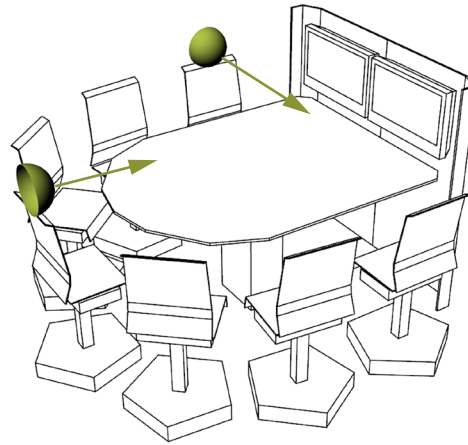
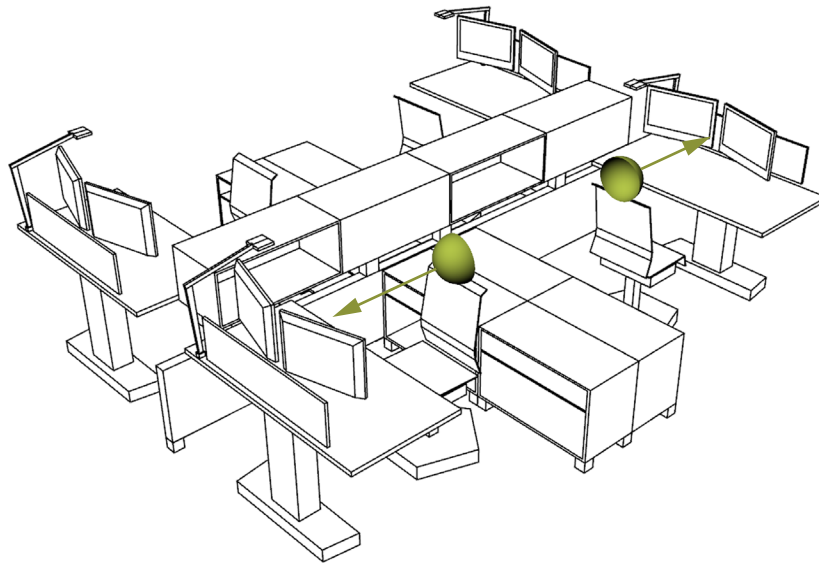

Figure 5-12: Individual viewpoints relative to different activity types and corresponding furniture layouts are incorporated to generate a global scheme of glarefunnels for all the investigated points of view within the floor layout



allows for higher level of customization in design and development of a shading devices.

### **ShadeFan: an adaptive shading system utilizing the GlareShade method**

Using the GlareShade method, a shading system relative to the investigated points of view at the simulation model is developed. The design process of the system is as follows:

- 1) Glarefunnels per individual viewpoints at a single point in time are generated.
- 2) A set of glareprofiles is produced as the result of intersection between the glarefunnels and the glazing surface on the perimeter of the floor plate.
- 3) Tubular rails on the exterior side of the glazing surface are added.
- 4) Developing a data processing algorithm, a shading region is produced relative to the location of glareprofiles on the glazing surface and the intersection points with the Tubular rails' central axis.
- 5) Node bolt balls are added on the intersection points.

6) Secondary structure hosted by the node bolt balls and tubular rails is added.

7) Shading fabric hosted by the shading structure is added.

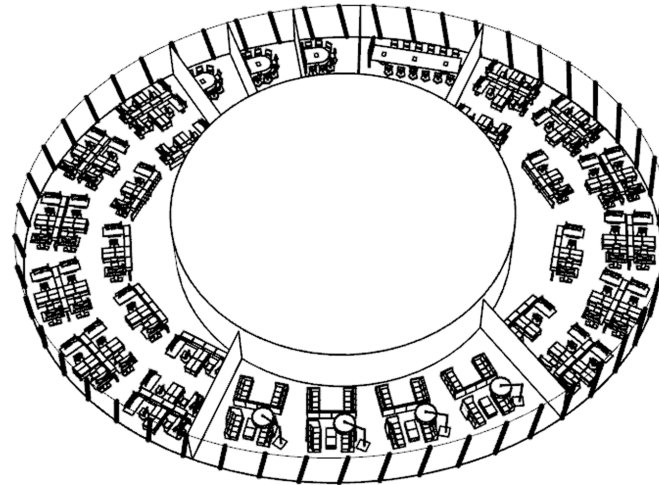

Figure 5-13: Glarefunnels per individual viewpoints at a single point in time are generated

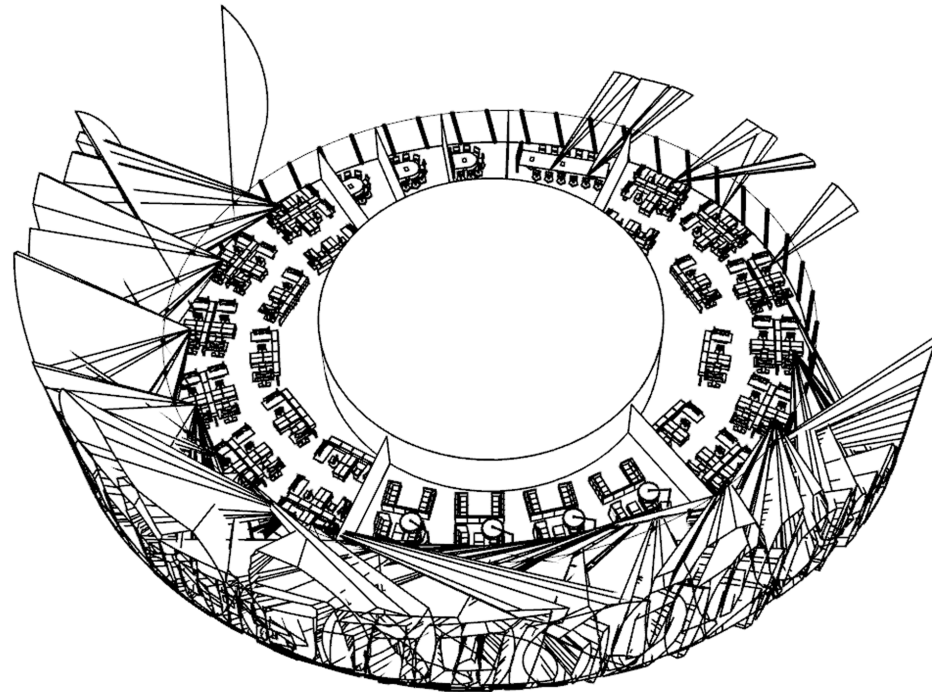

Figure 5-14: Exterior view of typical floor layout

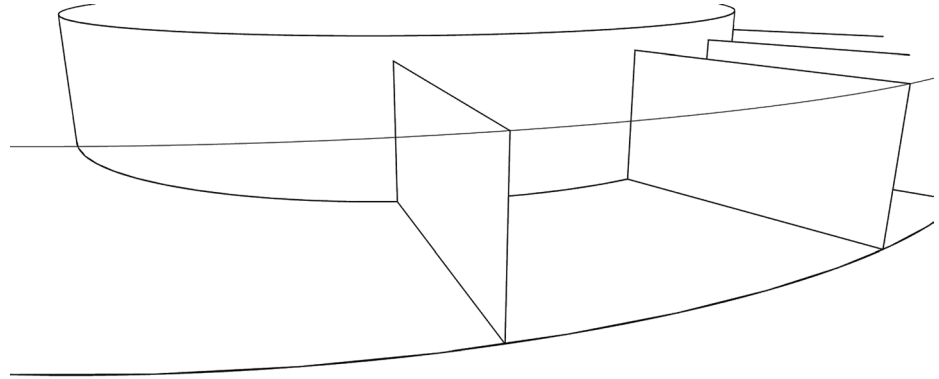

Figure 5-15: Glareprofiles regulated on the glazing surface

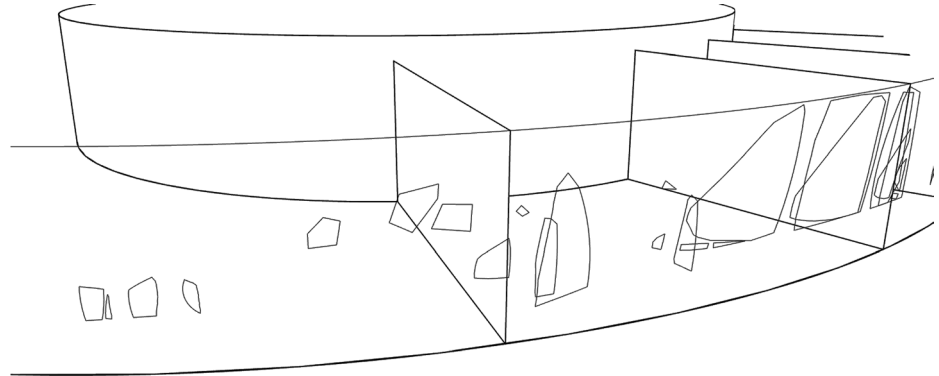

Figure 5-16: Tubular rails added at the exterior side of glazing surface

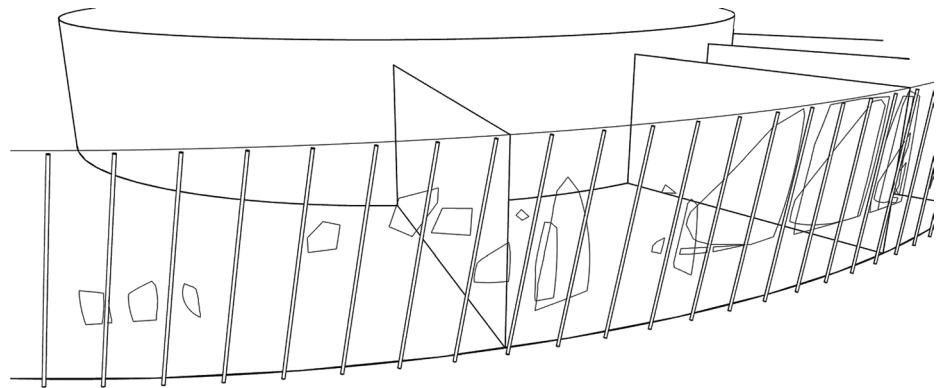

Figure 5-17: Shading regions are identified relative to the distribution of glareprofiles on the glazing surface

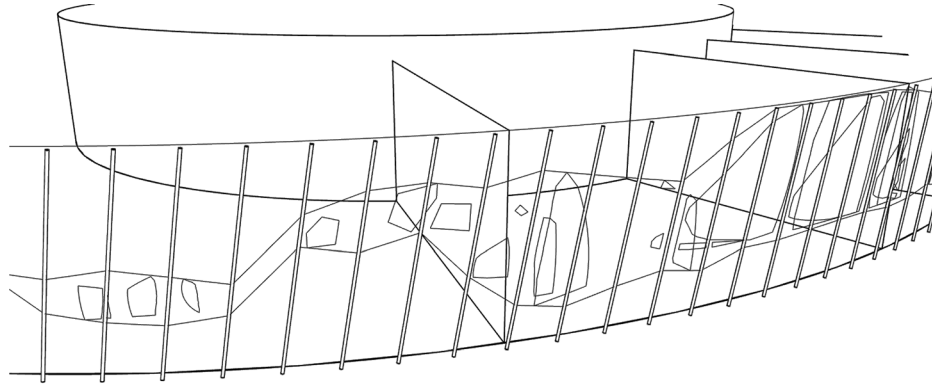

Figure 5-18: Node bolt balls are added on the intersections of shading region and tubular rails' central axis

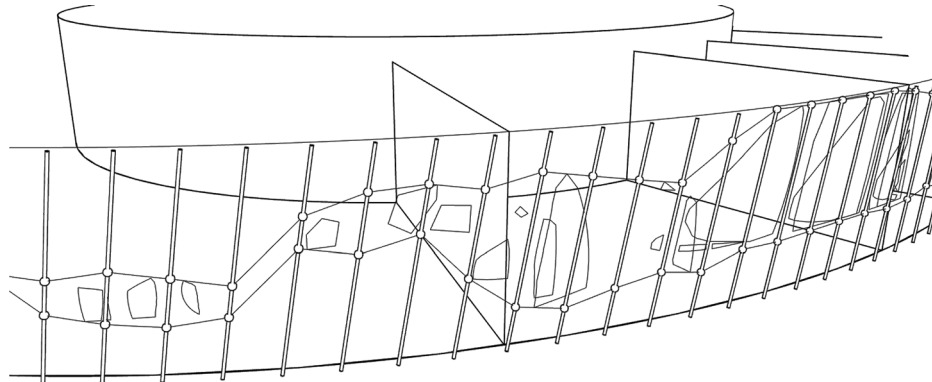

Figure 5-19: Applied secondary structure connecting the rails and nodes along the glazing surface

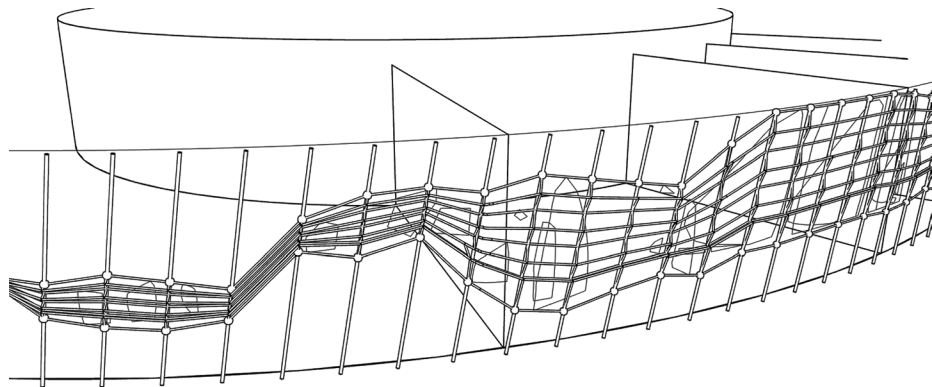

Figure 5-20: Point-in-time shading state driven by the kinetics of applied structure

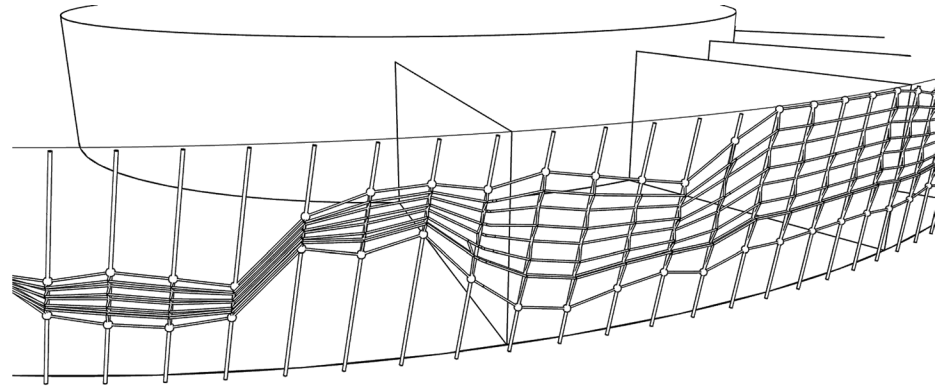

Figure 5-21: Kinetics of shading structure allow for adaptation to distinct shading states at different points-in-time

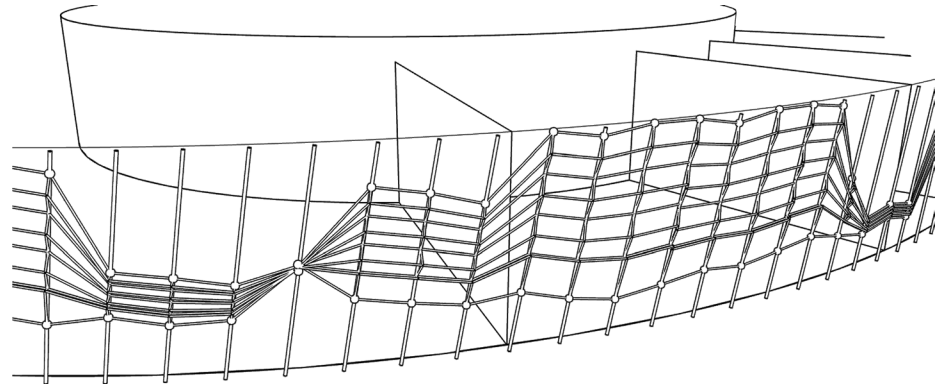
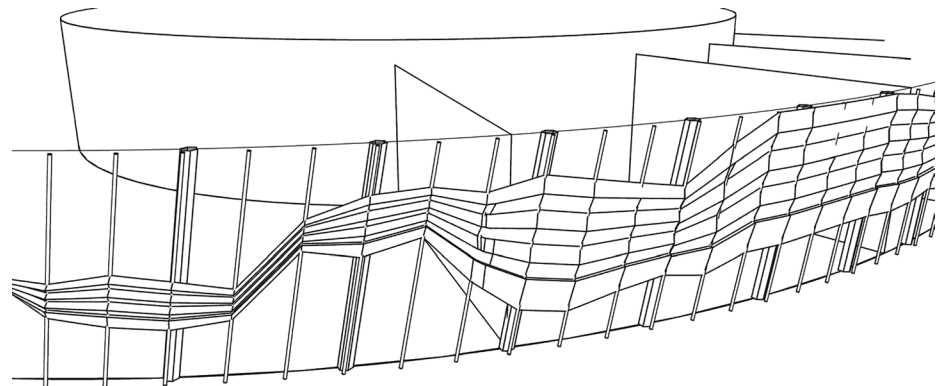

Figure 5-22: Shading fabric hosted by the shading structure reduces the luminance values relative to the target glareprofiles



## ShadeFan System: primary concepts and characteristics

- **Shading Region:**

The developed algorithm examines the geometry of individual glareprofiles, the distribution of profiles on the glazing surface and the location of central axis per individual rail. The outcome is a single shading region relative to a single set of glareprofiles. The outline of shading region is derived by the algorithm's evaluation according to which, a set of individual curves on the glazing surface is generated. The layout of the curves is based on the algorithm's evaluation results identifying the minimum distance between the curves' layout and the target glareprofiles on the glazing surface. Subsequently, the algorithm examines the consequent layout with the location of tubular rails' central axis. The result is an adjusted layout of curves on the glazing surface with three primary features:

- The start and ending points for individual curves are located, respectively, along the central axis of two consecutive tubular rail.
- All the curves located at upper or lower side (relative to a reference Z vector) of glareprofiles are connected at the starting/ending points resulting a continuous set of curves on both sides of the glareprofiles.



Figure 5-23: Northwest View, ShadeFan system applied on the building facade at the project site

- Considering the location of all starting/ending points of individual curves located along the central axis of tubular rails, the connection points at the starting/ending points between two consecutive curves will therefore, be always located along the central axis of tubular rails as well. These connection points are primarily important as they are referenced to locate node bolt balls along the tubular rails.

The consequent layout of curves on both sides of the glareprofiles segregates a portion of the glazing surface including the distributed glareprofiles. This layout is named as “ShadingRegion”. The layout of a single ShadingRegion is unique to the corresponding set of glareprofiles developed at a point in time.

- **Dynamism & Adaptability:**

The ShadeFan system deploys linear mechanical movement of node bolt balls along individual tubular rails. Individual node bolt balls serve as a mechanical joint where a set of mechanical arms are attached. The dynamics of node bolt balls, therefore, allows for controlling the dynamics of corresponding set of mechanical arms. In addition, the fan-like kinetics of individual sets of mechanical arms between two consecutive tubular rails allow for a broad range of contraction/expansion dynamics. Such hierarchy of dynamics between individual kinetic components

provides a higher level of geometrical/formal adaptability for the entire shading structure. The geometrical/formal adaptability is critical in order to address the glare issue at interior space(s) considering the ever-changing nature of shading regions produced per point in time.

Chapter 6  
**The GlareShade Method Evaluation**

## Chapter Contents Summary:

Simulation results corresponding with individual sets of examinations are presented to evaluate the GlareShade method's capability to address variations in the daylight distribution patterns at a given interior space and the consequent glare issues relative to the investigated viewpoints.

### Examination of GlareShade method

Using the digital model developed for a high-rise office building in Downtown Seattle, five sets of simulations are conducted. Individual sets of simulations target specific parameter(s) affecting the daylight distribution patterns for a given set of viewpoints. Shading diagrams corresponding with individual simulation sets represent the consequent shading schemes regulated by the GlareShade method and executed by the ShadeFan system.

- **Hours of a single day:** The simulation examines the GlareShade method's capability to address variations in the daylight distribution pattern at a given floor plan layout relative to different points in time at a single day. The spring equinox (March 21st) is selected as the target date for simulation. Three points in time (9:00 AM, 12:00 PM and 3:00 PM) are selected to study the variations of

luminance value distribution per point of view. Considering a total number of 40 floors are designated for office use in the study model, the 20th floor (with the median floor elevation value of 336 feet relative to the total number of office floors), is selected to study the glare issue per viewpoint. The result of the developed shading schemes at target points in time are presented.

- **Hours of a single day – No site context:** With an exception of the surrounding building context, simulation assumptions are identical to those used for the “Hours of a single day” tests. The building context of Downtown Seattle is eliminated from the set of simulation assumptions in order to study the effect of building mass geometries and applied material properties relative to building facades on the distribution of luminance values at a given interior space per viewpoint at target points in time. Consequent shading schemes per point in time are presented.

### Hours of a single day:

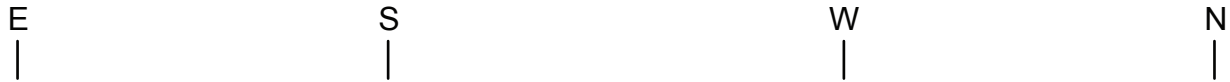

**Mar 21 09:00**  
clear sky w/ sun

**20th Floor**



**Mar 21 12:00**  
clear sky w/ sun

**20th Floor**

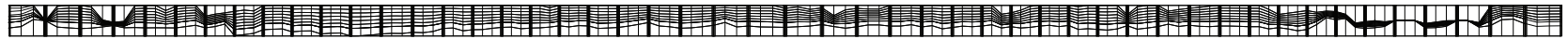

**Mar 21 15:00**  
clear sky w/ sun

**20th Floor**

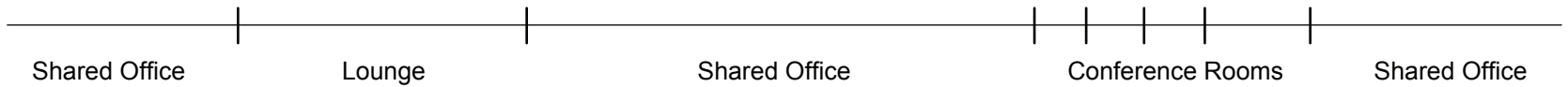

### Hours of a single day - No site context:

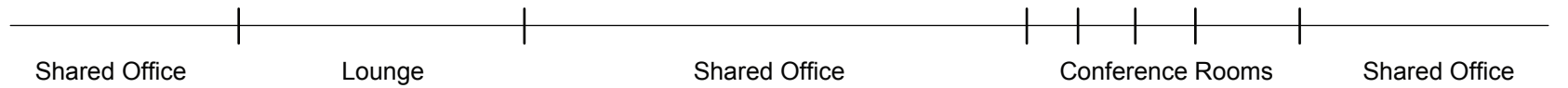
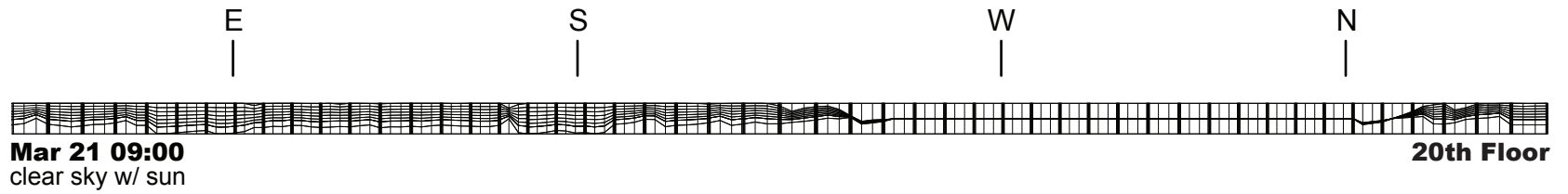

### Site context and the issue of uncontrolled reflective facades:

Consequent shading schemes for the two simulation sets (Hours of a single day, with and without the site context) are compared: The shading scheme developed for simulations with no surrounding context presents less obstruction of glazing surface in comparison with the shading states corresponding with simulations including the site context.

While the results of analogies between the two sets of shading states appears to be counterintuitive, the GlareShade method's regulation for higher level of obstruction in the situations where the building context is included in the simulation assumptions is valid:

The reflection of light rays by the building facades of surrounding site context causes glare problem at the investigated viewpoints. As a result, the GlareShade method's algorithm developed to identify problematic luminance values per viewpoint regulates more corresponding glareprofiles on the glazing surface. The regulated glareprofiles are then addressed via the ShadeFan system. Consequently, higher level of shading is applied to tackle the glare issue caused by the uncontrolled reflective facades of the surrounding building context.

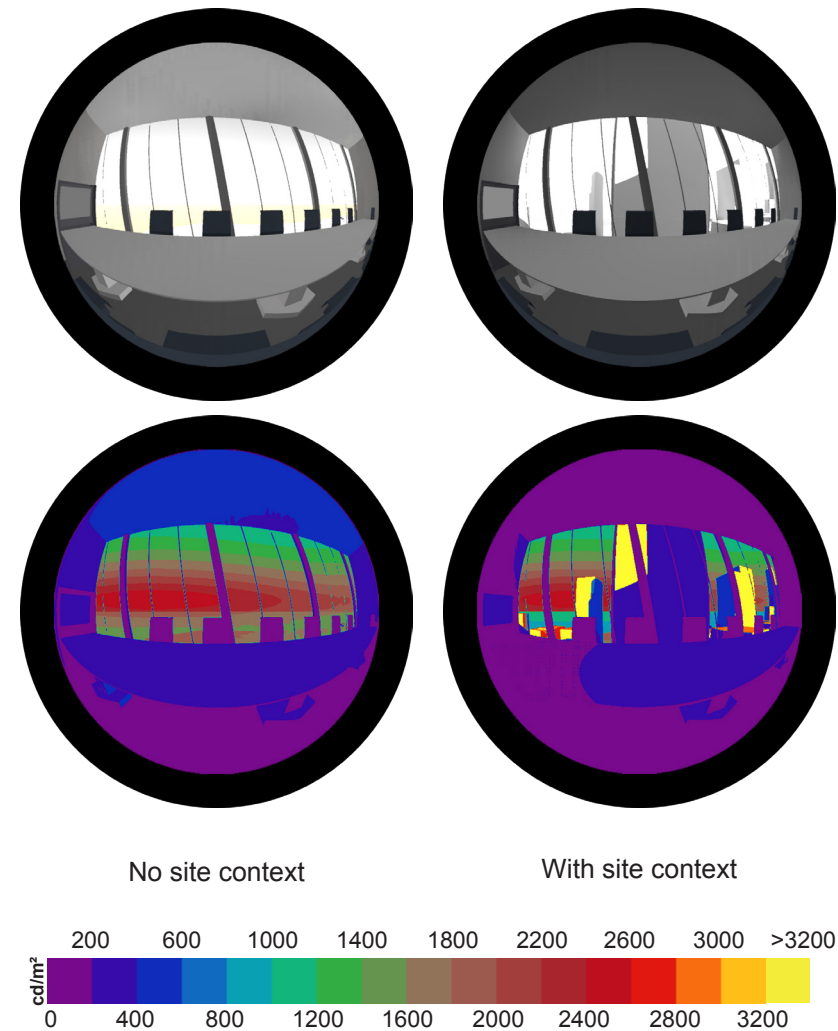

**March 21st 09:00**  
 Clear Sky W/ Sun

Figure 6-1: The effect of uncontrolled reflective facades on the daylight distribution pattern and corresponding range of luminance values is studied for a single point of view at a point in time

- **Solstice and Equinox Dates:** Summer and winter solstice as well as the spring equinox (June 21st, December 21st and March 21st, respectively) are selected to evaluate the GlareShade method's capability to address variations in daylight distribution pattern and probable glare issues per viewpoint relative to distinct sky conditions and sun angles at different times of the year. A single time of the day (12:00 PM) is verified as constant in simulation assumptions. Consequent shading schemes are presented.
- **Variable Thresholds vs. Constant Threshold:** Two sets of simulations are conducted to evaluate the GlareShade method's capability to incorporate individuals' preferences in glare evaluation process by customizing the thresholds per viewpoint. Constant date and time (March 21st at 12:00 PM) along with a single sky condition (clear sky with sun) are incorporated in both sets of simulation assumptions. Consequent shading schemes are presented.

### Solstice and Equinox dates at a point in time:

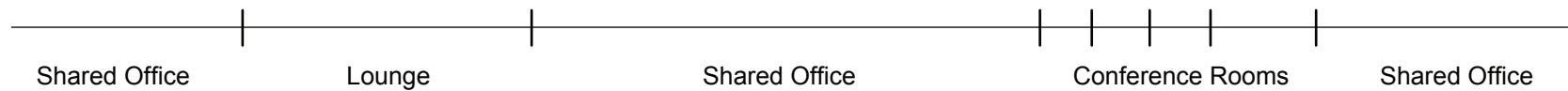
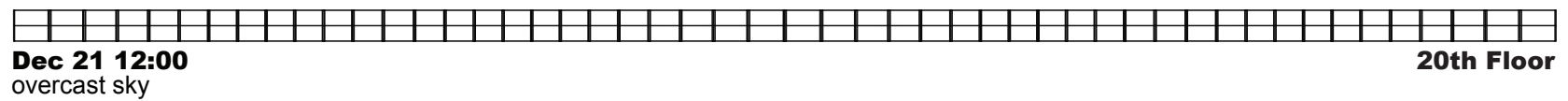
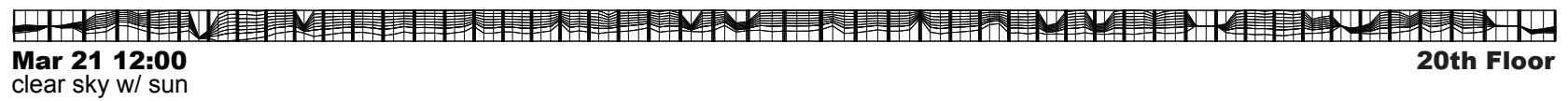
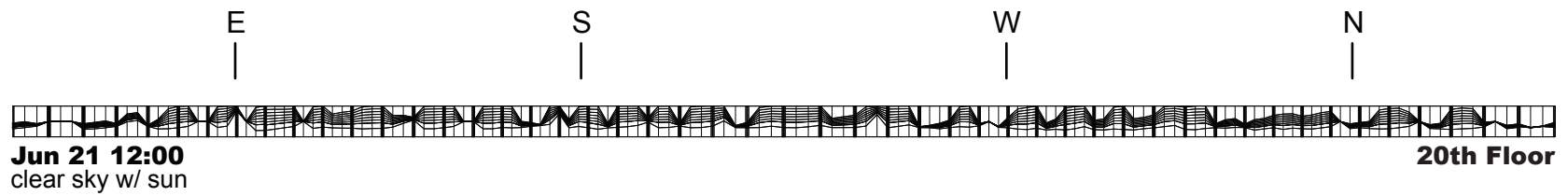

**Variable Vs. Fixed threshold at shared office spaces:**

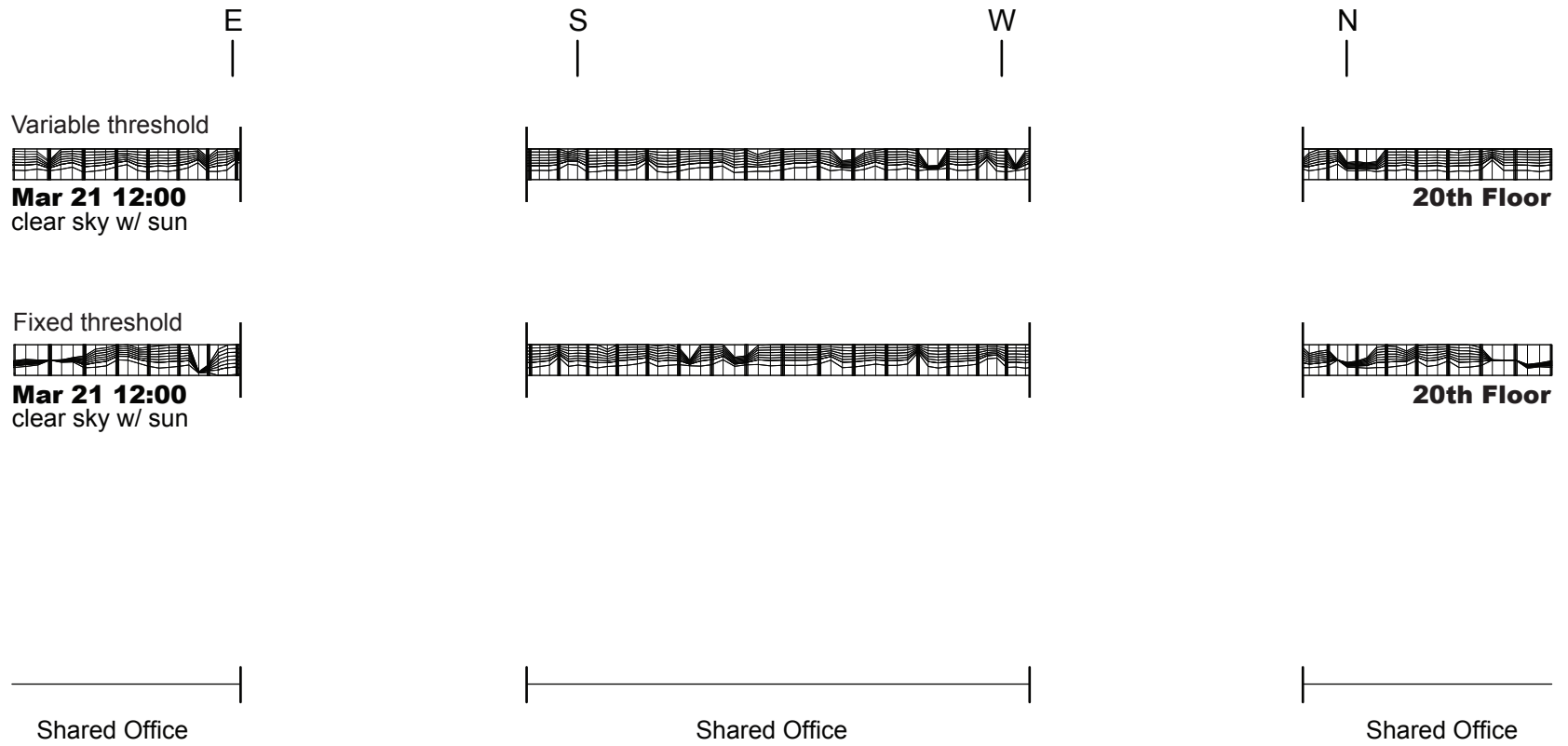

- **Variable Elevation:** With a total number of 40 floors designated for office use, three office floors are selected to examine the GlareShade method's capability to address variations in interior daylight distribution per viewpoint relative to different floor elevations. The minimum and maximum office floor elevations (70 feet and 616 feet at the 1st and 40th floors, respectively), as well as the median floor elevation (336 feet at 20th floor) are selected. The spring equinox, March 21st, at 12:00 PM is determined as the constant date and time in simulation assumptions. The sky condition in all three simulations is defined as "clear sky with sun". Considering the rotation of individual floor plates' position around the building's core (relative to the preceding floor plates along the elevation), the consequent shading diagrams also represent variations in shading schemes per activity types according to the orientation of each individual space (e.g. the Lounge areas) relative to the cardinal directions and different juxtapositions with the adjacent building context.

### Variable elevation at a point-in-time:

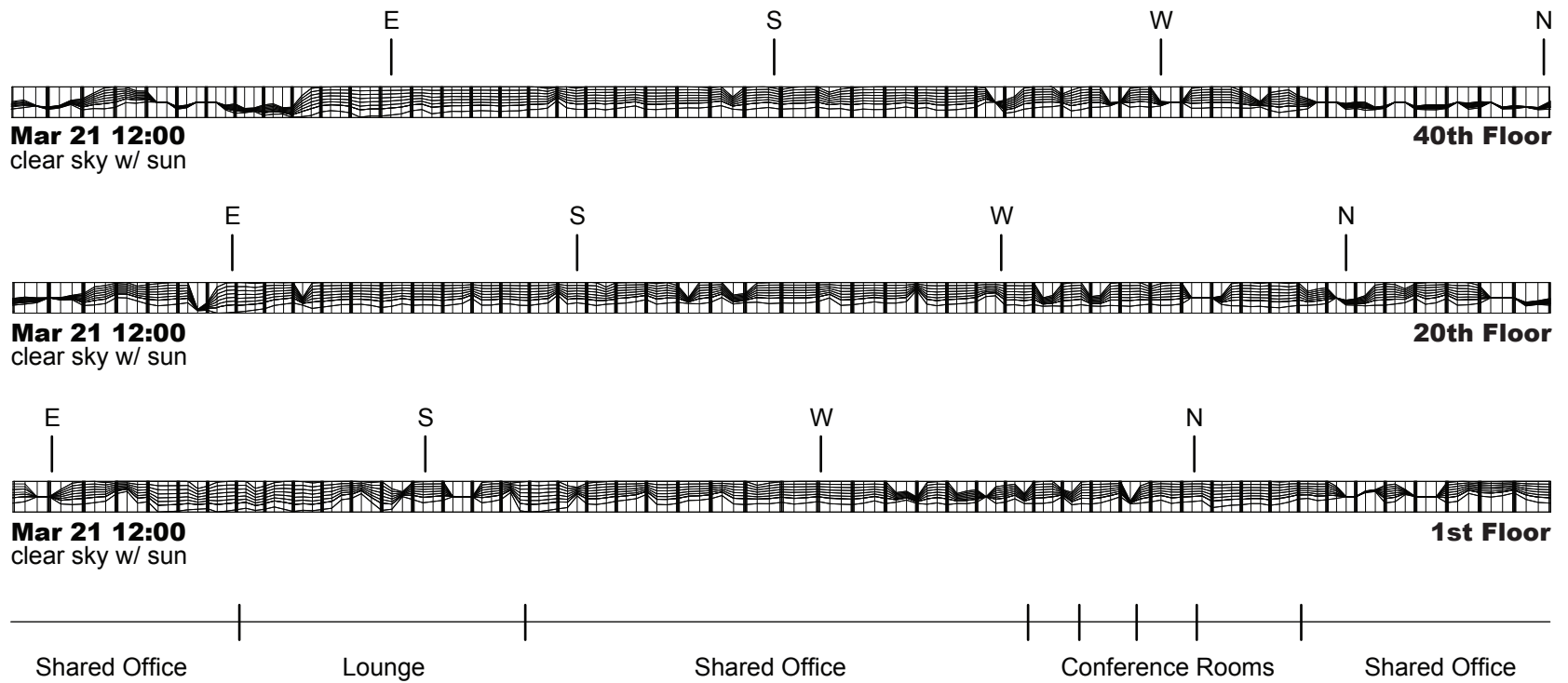



Chapter 7  
**Conclusions**

## **Chapter Contents Summary:**

Conclusions exploring the underlying metrics in GlareShade method are presented. Characteristics of adaptive shading systems utilizing the GlareShade method are demonstrated. Primary features of the GlareShade method are presented.

## **Underlying Metrics in GlareShade Method**

The glare control approach taken by the GlareShade method can be categorized in two separate set of procedures: First, the sets of data analysis and evaluations leading to identification of glare problem at target viewpoint(s) and verification of problematic regions of luminance values causing the glare problem relative to individuals' points of view.

Second, the process of regulating responses for an adaptive shading system by defining glareprofiles on glazing surface(s) at a given interior space.

Considering such categorization of glare control procedures via the GlareShade method, it is important to signify the GlareShade method's capability allowing for using different glare control metrics and indices for the first category of data analysis leading to identification of problematic glare regions within the target viewrange.

Using the GlareShade method, one can utilize the Daylight Glare Probability metric (instead of the Glare Evaluation Based on Upper Threshold metric according to which, the native algorithm of GlareShade method is developed) to identify problematic glare regions for a target point of view and subsequently, deploy the GlareShade method's algorithms only to produce glareprofiles (corresponding with glare regions identified via DGP's algorithm) on the glazing surfaces.

#### **GlareShade Method & Precedent Shadow-range Studies for Direct Sun Patch Penetration:**

According to the precedent daylighting control strategies relying on shadow-range studies to evaluate the visual comfort of occupants, the obstruction of direct sun patch by shading devices and/or the surrounding building context is verified as the proof for visual comfort and experiencing no glare issues at the viewpoints that are located within the shadow region. This argument is not valid for two reasons:

First, the source of the problematic luminance values (luminance values equal to and/or greater than the identified threshold causing the glare problem) is not limited to the disk of the sun. Uncontrolled reflective facades of the surrounding building context are a common source of problematic luminance values. However, the shadow-range study is not capable to

verify such glare sources and thus, it is highly probable that a single point of view that is under shadow experiences the glare problem due to the reflected light rays fallen within its viewrange.

Second, the glare is a visual discomfort experience within an individual's viewrange. However, shadow-range studies consider individual planar surfaces to examine the penetration of direct sun patch to the interior space. As a result, even a shadowrange study that uses a planar surface at the eye-level corresponding with target viewpoint(s) fails to present a comprehensive approach to evaluate the probability of glare issue limited to experiencing the disk of the sun within the viewrange. An individual's viewrange is broader than a set of coplanar points at the eye-level. Therefore, it is highly probable that an individual at target point of view experiences portions of the disk of the sun within his/her viewrange while a single shadow-range study at an eye-level plane fails to identify such glare problem.

## **Adaptive Shading Systems Utilizing the GlareShade method:**

Presented approach by the GlareShade method allows the designers to deploy a separate shading system, like the ShadeFan, in order to exclusively address the issue of glare. The capability to exclusively address the glare issue with a separate set of shading devices allows the designers to:

First, tackle the design/construction problems related to integration of glare control shading devices with other façade assemblies. Regulated glareprofiles on the glazing surfaces can be addressed by either an interior or exterior shading system. Such flexibility in the location of the shading devices provides more options for the designers to integrate the glare control shading system with the complex set of façade assembly layers.

Second, address the competing shading solutions relative to individual daylight properties like optimization of solar heat gain, illuminance values on task surfaces and glare issue per target viewpoints due to the separation of shading systems per individual sets of control tasks. Therefore, mediocre solutions caused by consolidation of all competing responses executed by one set of shading devices can be enhanced based on the separation of glare control shading devices from other shading systems.

## GlareShade Method: Primary Features

The thesis presents the development of an adaptive shading technique called GlareShade. GlareShade is an occupant-centric shading method that utilizes distributed sensing approach to control the shading devices. An adaptive shading system is developed as an example of the application of GlareShade method.

- **GlareShade Method: A Global Distributed Sensing Approach**

The GlareShade method allows for identification of glareprofile(s) relative to an individual's point of view at a single point in time. By expanding the application of GlareShade method for the entire viewpoints relative to the layout of a given interior space, a set of glareprofiles are identified. The masking of consequent set of glareprofiles will address the glare issue. As a result, the GlareShade method is a global distributed sensing approach according to which, all individual points of view distributed within the layout of an interior space are examined in order to reach a shading scheme that addresses the glare problem for every single viewpoint at a point in time.

Figure 7-1: Northwest View | ShadeFan, an adaptive shading system developed based on the application of GlareShade method, is utilized on the building's facade at the project site



- **GlareShade Method: An Occupant-Centric Approach**

The GlareShade method examines individual viewpoints to identify segment(s) of a view range where the luminance values are recognized as problematic according to the target threshold (e.g. 3000 cd/m<sup>2</sup>). Every single individual has a unique set of preferences that distinguishes the minimum luminance value, identified as the threshold, in comparison with other individuals at the same point of view and point in time. Using the luminance distribution image and corresponding falsecolor image per point of view, the GlareShade method allows for applying a separate threshold based on an individual's preferences. Therefore, the GlareShade method recognizes the glare issue as a visual discomfort experience that is dependent on an individual's tolerance for the range of luminance values distributed in his/her viewrange and thus, allows for using separate thresholds per viewpoint in its glare evaluation process. Such plurality of sensing preferences results in a global shading scheme where every single individual's preferences is incorporated.

# Citation

- **Chapter 1**

1. David L. DiLaura, Kevin W. Houser, Richard G. Mistrick, Gary R. Steffy. Illuminating Engineering Society Lighting Handbook: Reference & Application. Illuminating Engineering Society of North America, 2011, Page 4.26

- **Chapter 2**

1. <http://www.archdaily.com/162101/ad-classics-institut-du-monde-arabe-jean-nouvel/>
2. <http://www.adaptivebuildings.com/tessellate-surface.html>
3. <http://www.adaptivebuildings.com/strata-surface.html>
4. <https://www.som.com/news/heliotrace-fa-ade-system-featured-popular-science-s-best-what-s-new>
5. <http://www.archdaily.com/?p=326747>
6. <http://www.archdaily.com/?p=101578>
7. <http://www.fastcodesign.com/1662975/mighty-building-facade-beats-solar-heat-with-mechanical-muscles>
8. <http://www.archdaily.com/?p=270592>

- **Chapter 3**

1. Jan Wienold, Jens Christoffersen, Evaluation methods and development of a new glare prediction model for daylight environments with the use of CCD cameras, Energy and Buildings, Volume 38, Issue 7, July 2006, Pages 743-757
2. Wienold, Jan. "Dynamic daylight glare evaluation." In Proceedings of Building Simulation, pp. 944-951. 2009.
3. <http://cms.allsteeloffice.com/SynergyDocuments/ErgonomicsAndDesignReferenceGuideWhitePaper.pdf>

- **Chapter 4**

1. <http://www.steelcase.com/en/Pages/Homepage.aspx>

## References

- Aksamija, Ajla. Sustainable Facades : Design Methods for High-Performance Building Envelopes. Hoboken: Wiley, 2013
- Köster, Helmut, Dynamic Daylighting Architecture: Basics, Systems, Projects. Springer, 2004
- Syed, Asif. Advanced Building Technologies for Sustainability. Hoboken: Wiley, 2012
- Wienold, Jan. "Dynamic daylight glare evaluation." In Proceedings of Building Simulation, pp. 944-951. 2009
- Y.W. Fung, W.L. Lee, Developing a simplified parameter for assessing view obstruction in high-rise high-density urban environment, Habitat International, Volume 36, Issue 3, July 2012, Pages 414-422,
- Werner K.E. Osterhaus, Discomfort glare assessment and prevention for daylight applications in office environments, Solar Energy, Volume 79, Issue 2, August 2005, Pages 140-158

- Jan Wienold, Jens Christoffersen, Evaluation methods and development of a new glare prediction model for daylight environments with the use of CCD cameras, Energy and Buildings, Volume 38, Issue 7, July 2006, Pages 743-757
- Shenqiu Zhang, Dagnachew Birru, An open-loop venetian blind control to avoid direct sunlight and enhance daylight utilization, Solar Energy, Volume 86, Issue 3, March 2012, Pages 860-866
- Ji-Hyun Kim, Young-Joon Park, Myoung-Souk Yeo, Kwang-Woo Kim, An experimental study on the environmental performance of the automated blind in summer, Building and Environment, Volume 44, Issue 7, July 2009, Pages 1517-1527
- David L. DiLaura, Kevin W. Houser, Richard G. Mistrick, Gary R. Steffy. Illuminating Engineering Society Lighting Handbook: Reference & Application. Illuminating Engineering Society of North America, 2011, Pages 4.26-4.29

**Appendix A Room Depth Parameter: Simulation Results**

Date	Time	Sky Condition
March 21st	12:00	Overcast
Jun 21st	12:00	Clear with Sun
December 21st	12:00	Overcast

Appendix A: Point-in-time illuminance simulation assumptions

# Room Depth:

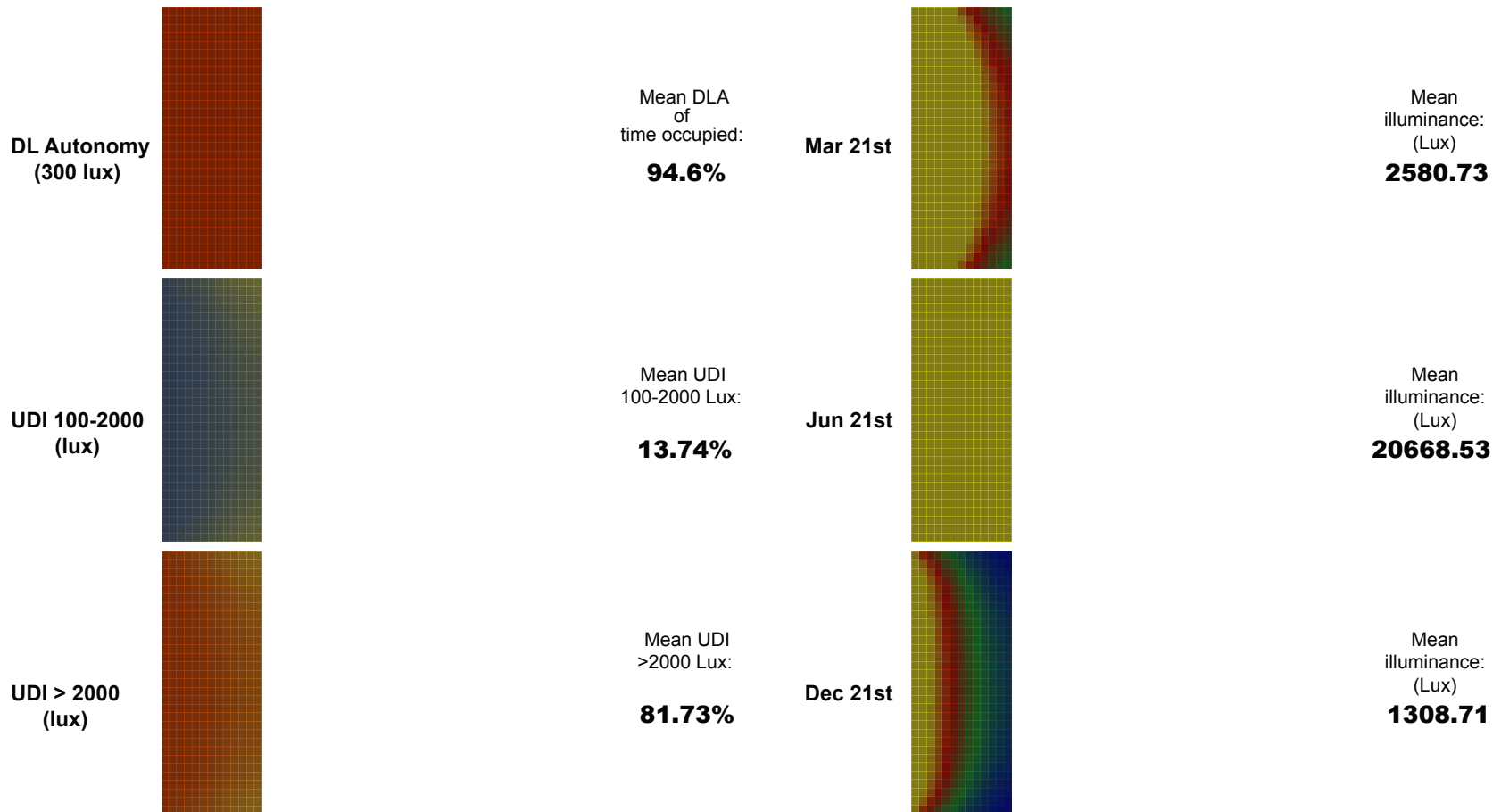
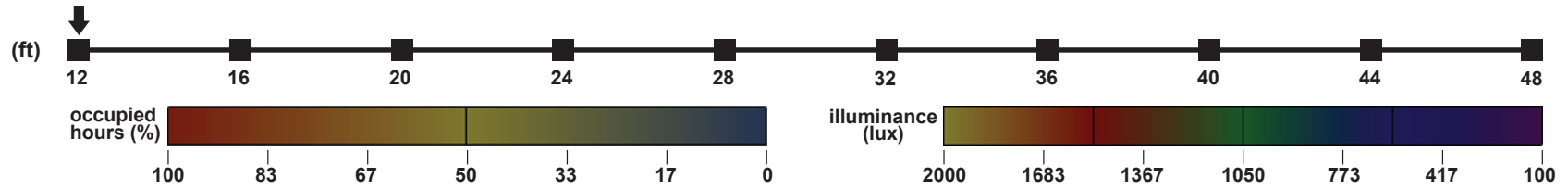

# Room Depth:

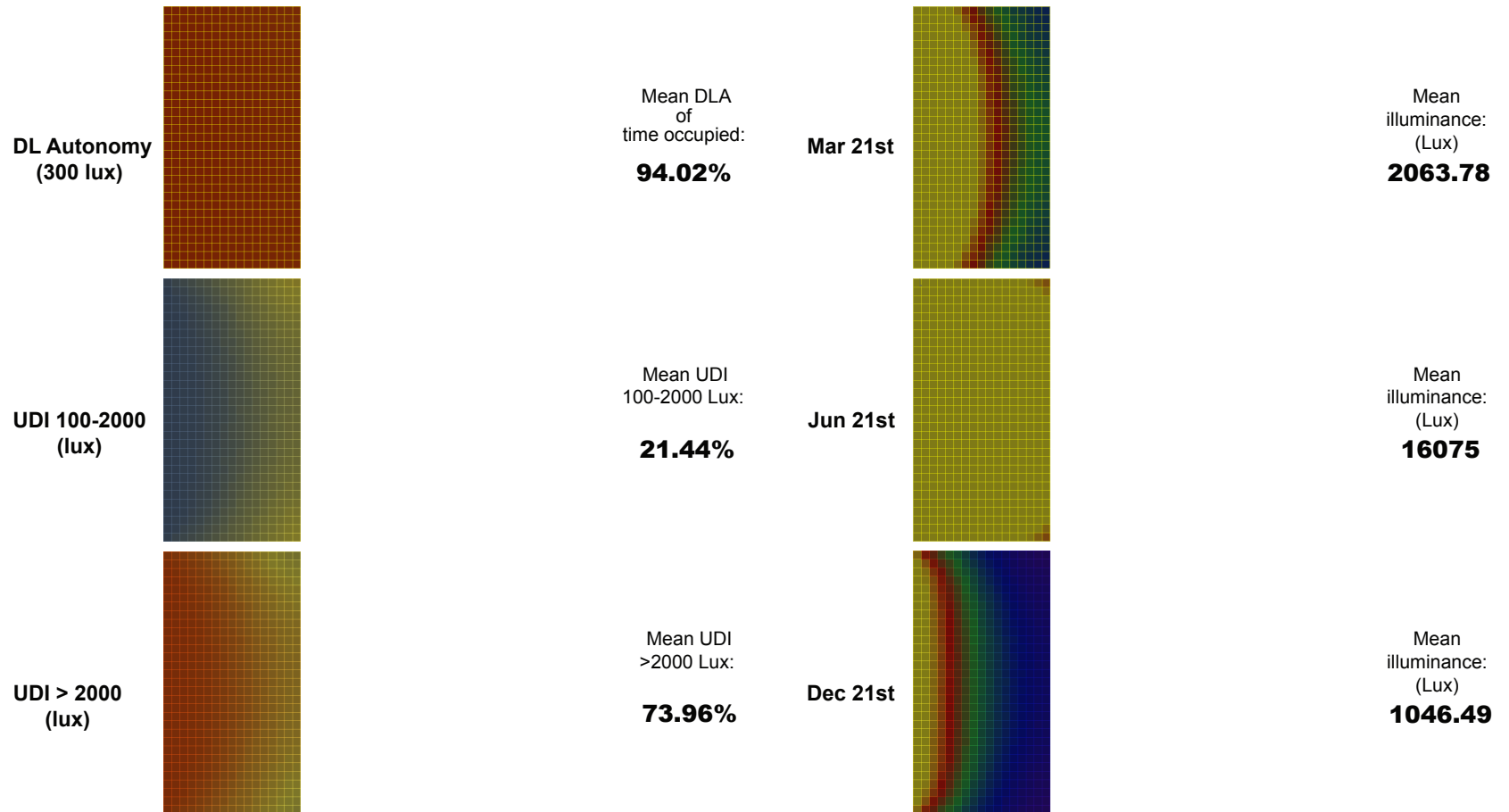
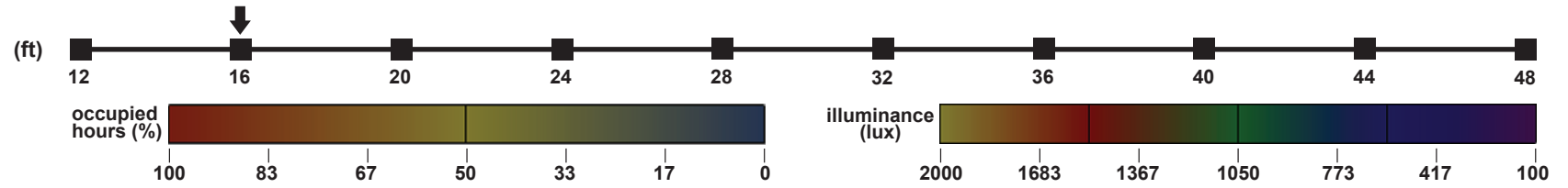

# Room Depth:

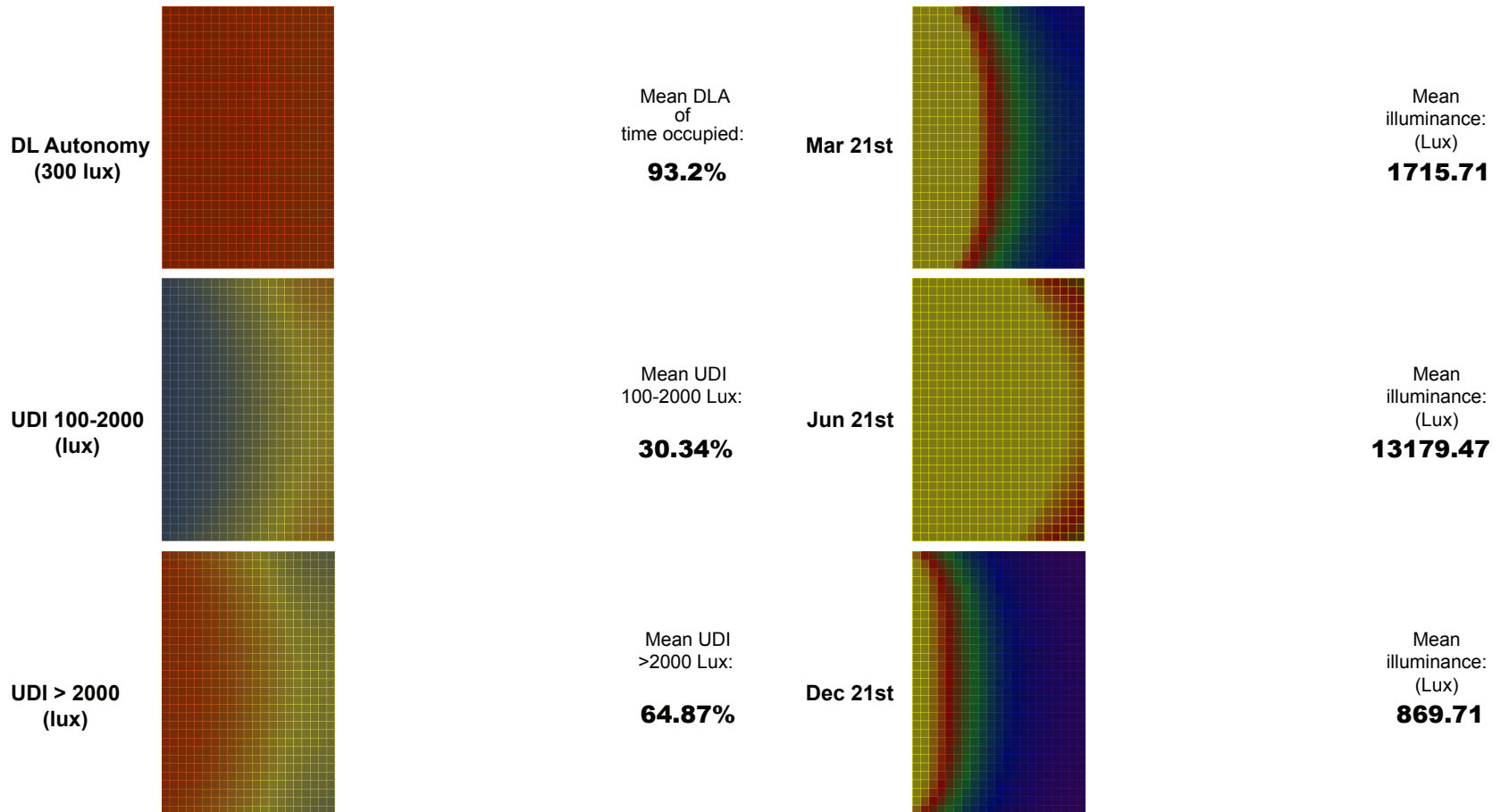
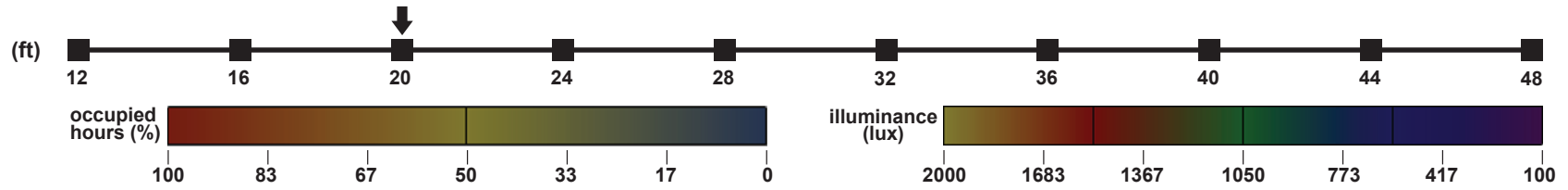

# Room Depth:

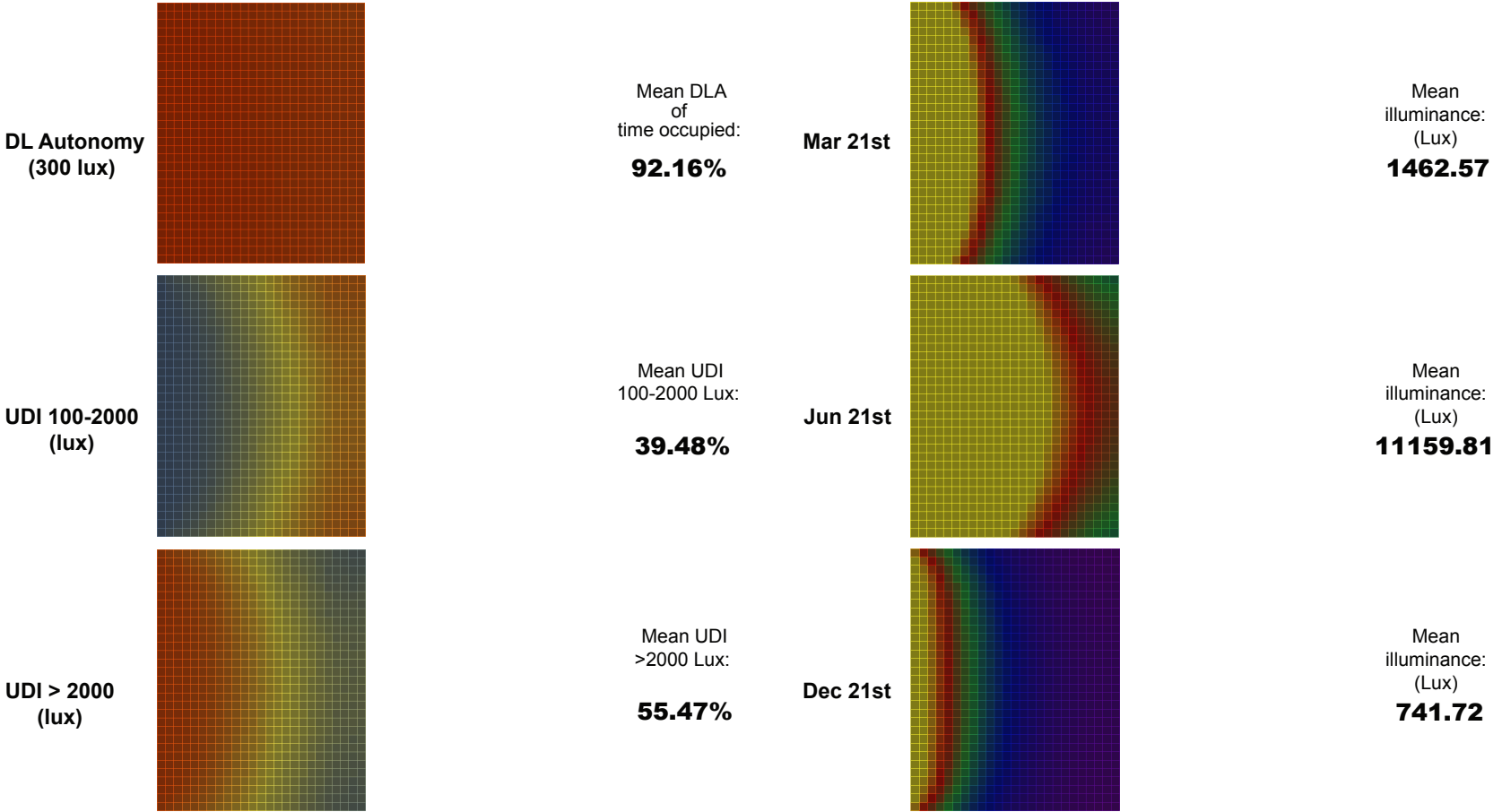
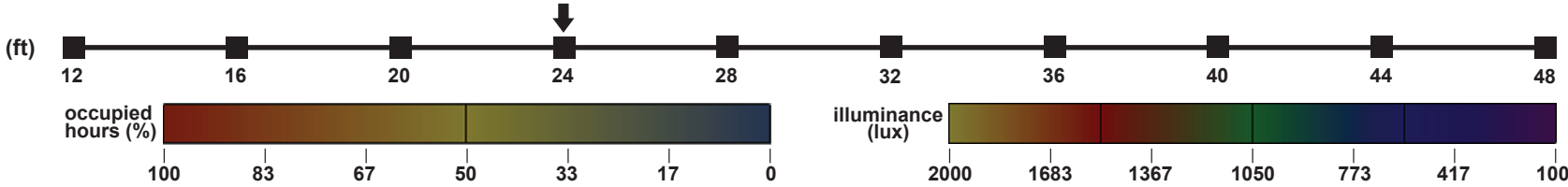

# Room Depth:

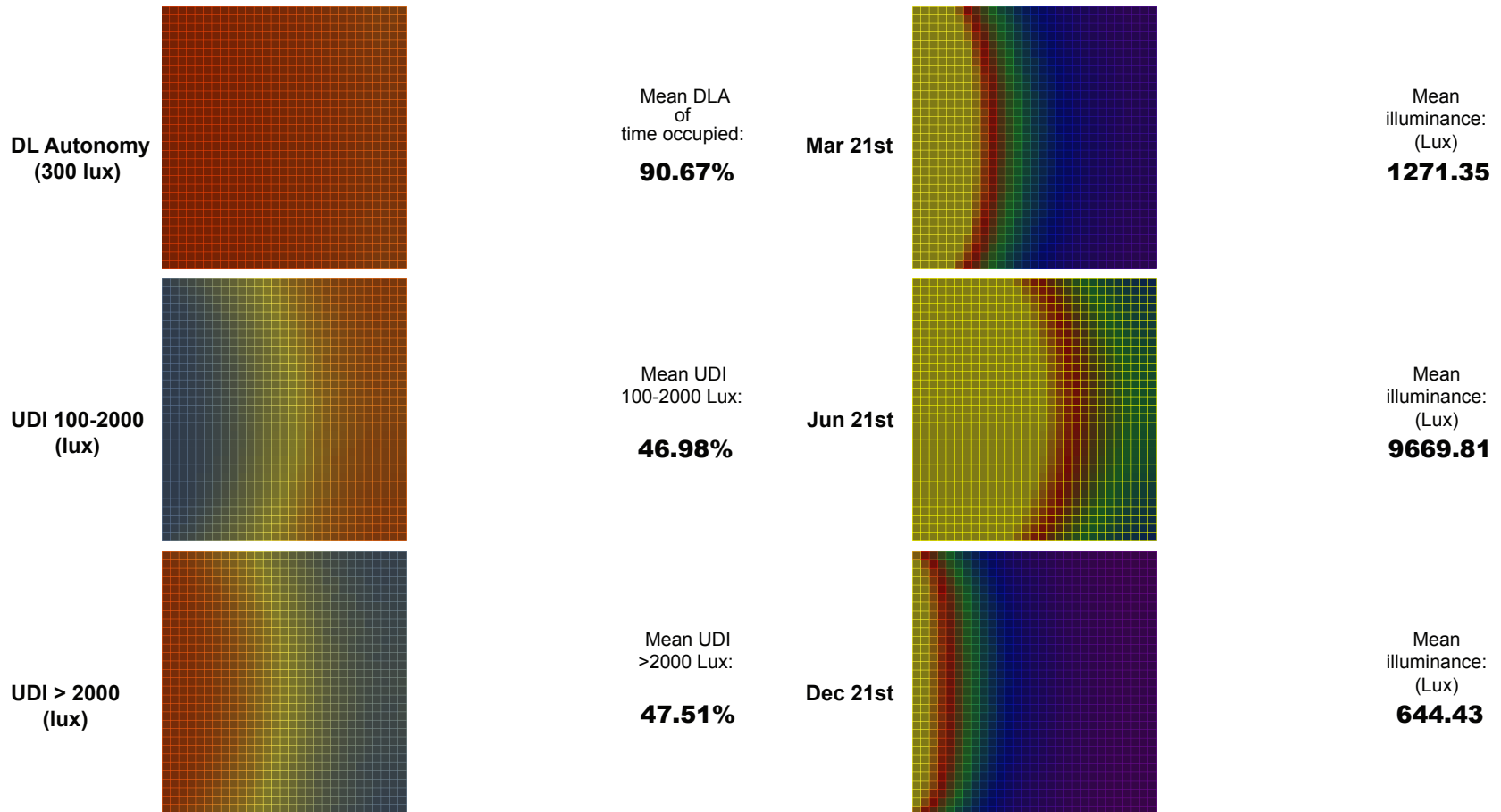
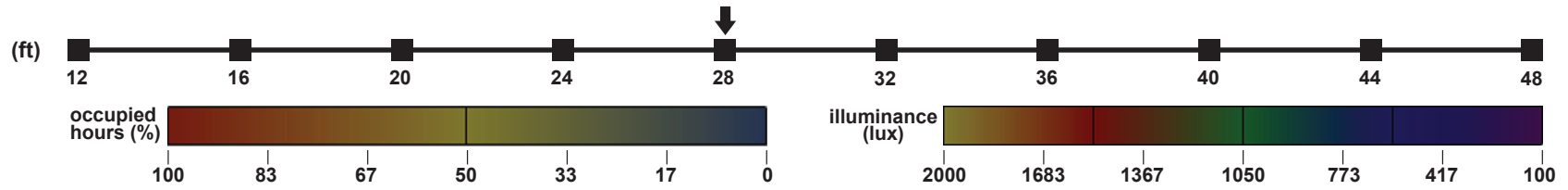

# Room Depth

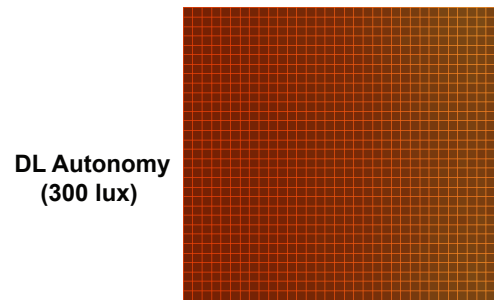
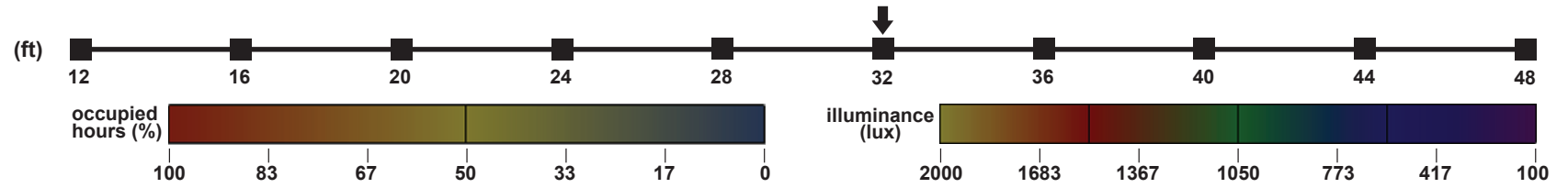

DL Autonomy  
(300 lux)

Mean DLA  
of  
time occupied:  
**88.43%**

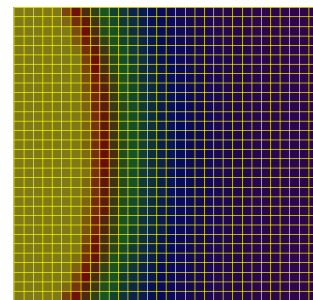

Mar 21st

Mean  
illuminance:  
(Lux)  
**1122.17**

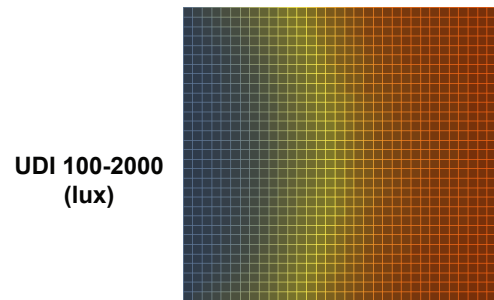

UDI 100-2000  
(lux)

Mean UDI  
100-2000 Lux:  
**52.85%**

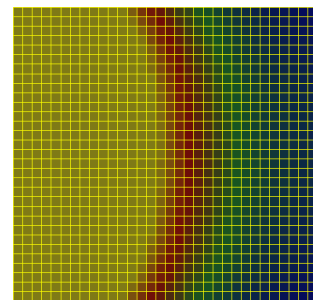

Jun 21st

Mean  
illuminance:  
(Lux)  
**8523.29**

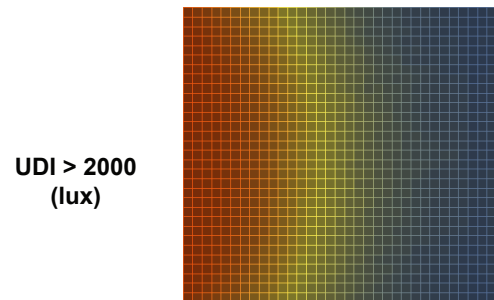

UDI > 2000  
(lux)

Mean UDI  
>2000 Lux:  
**41.11%**

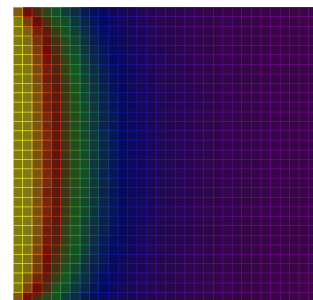

Dec 21st

Mean  
illuminance:  
(Lux)  
**568.44**

# Room Depth:

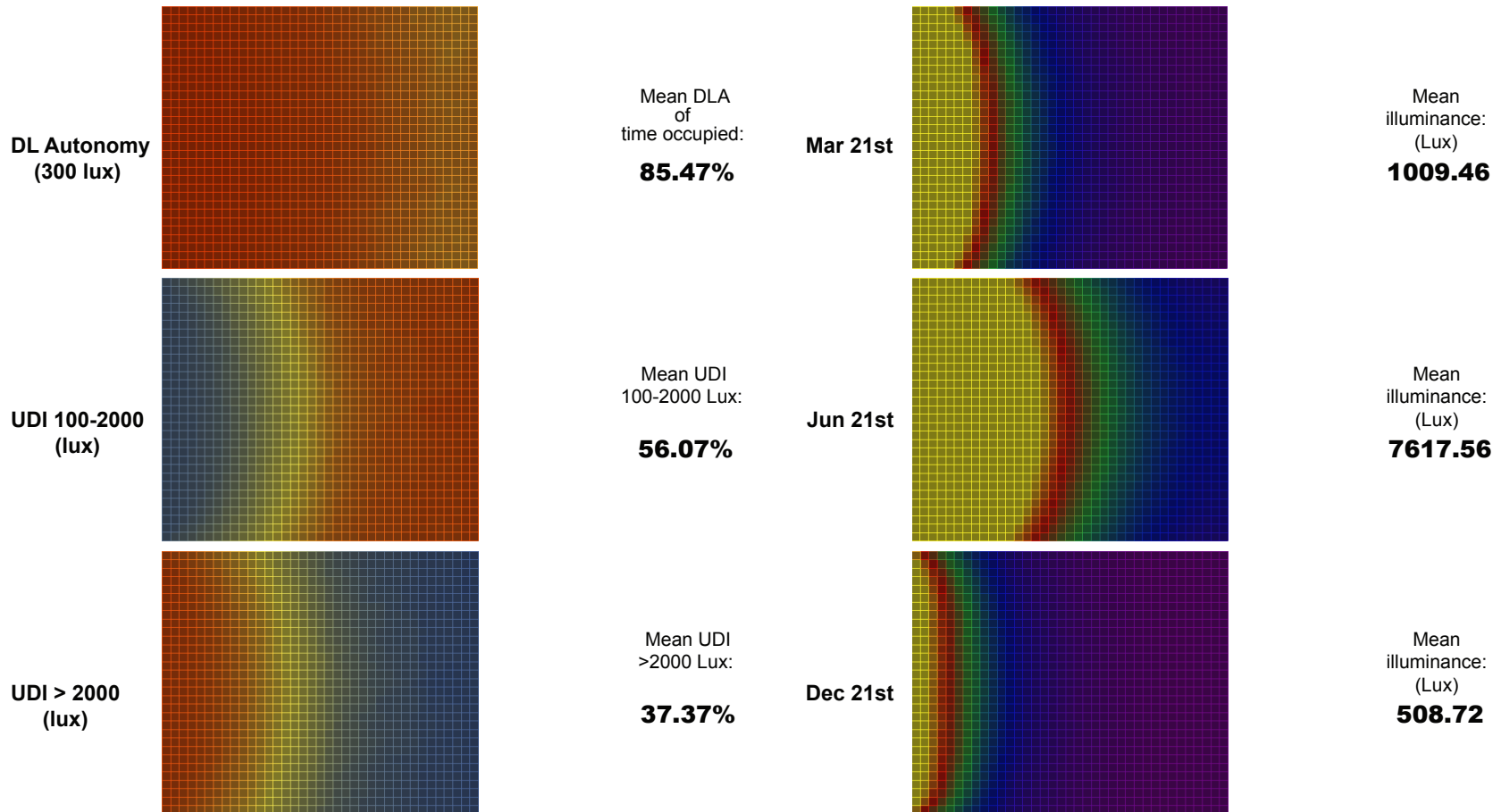
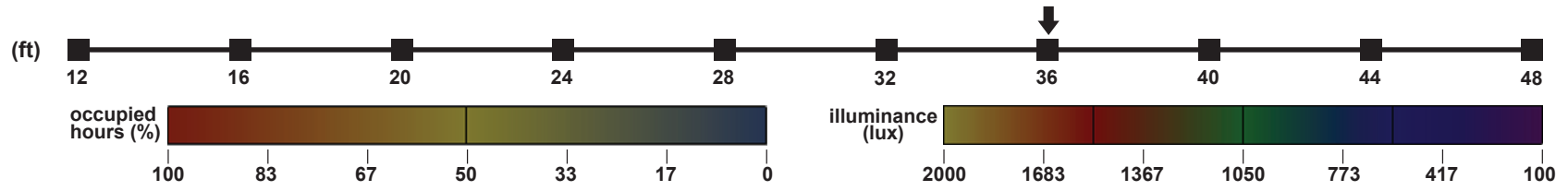

# Room Depth

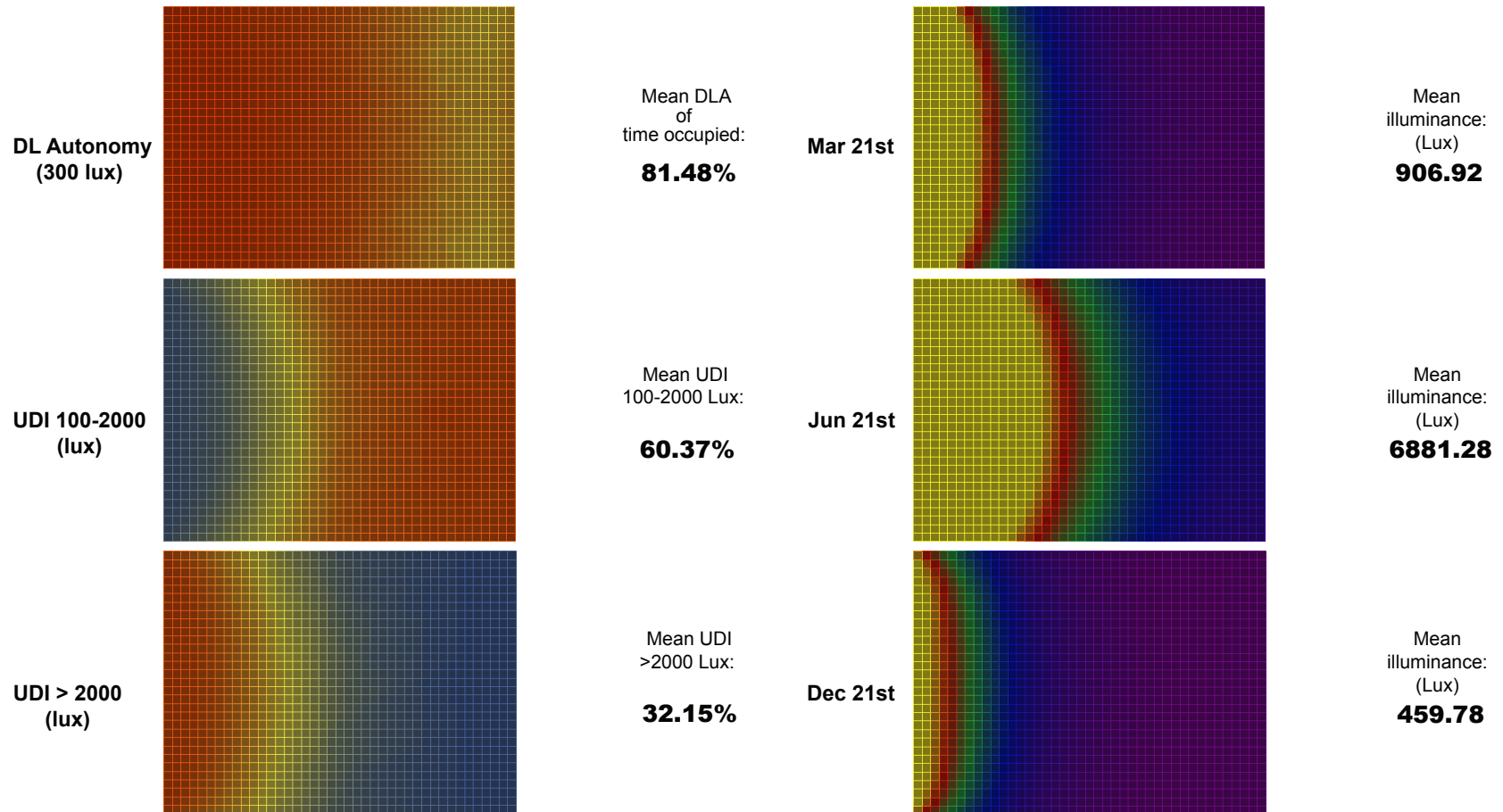
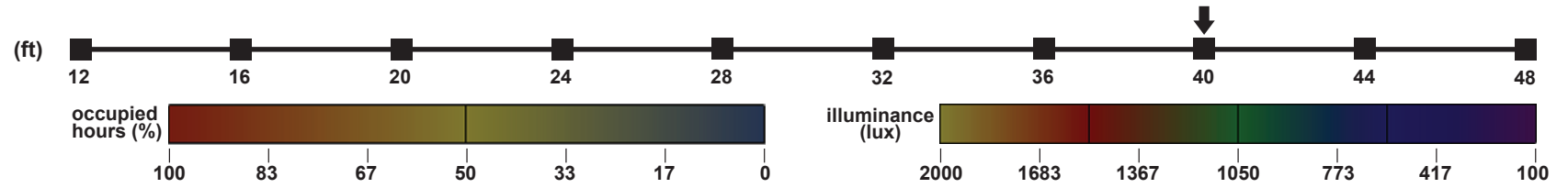

# Room Depth:

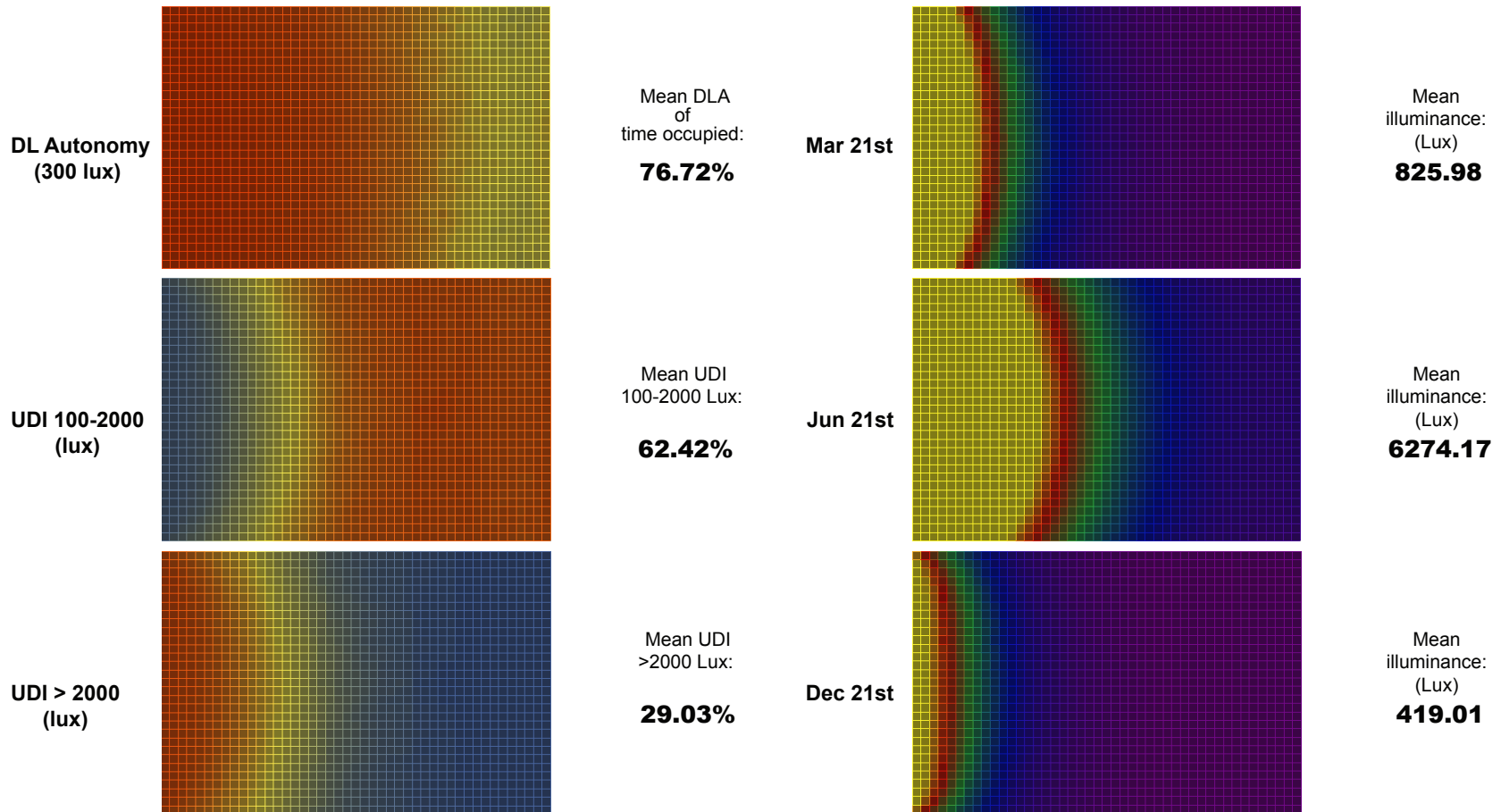
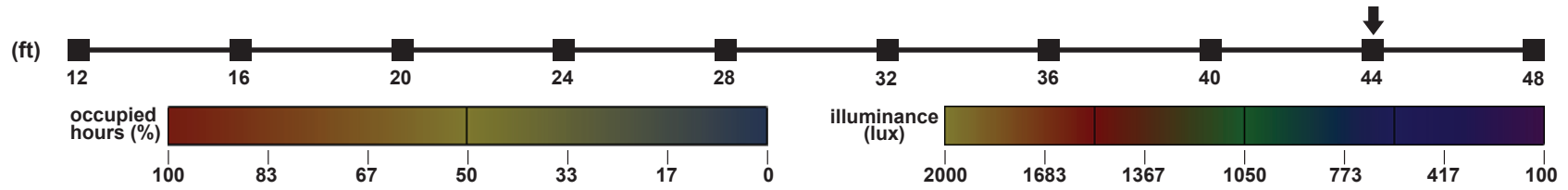

# Room Depth

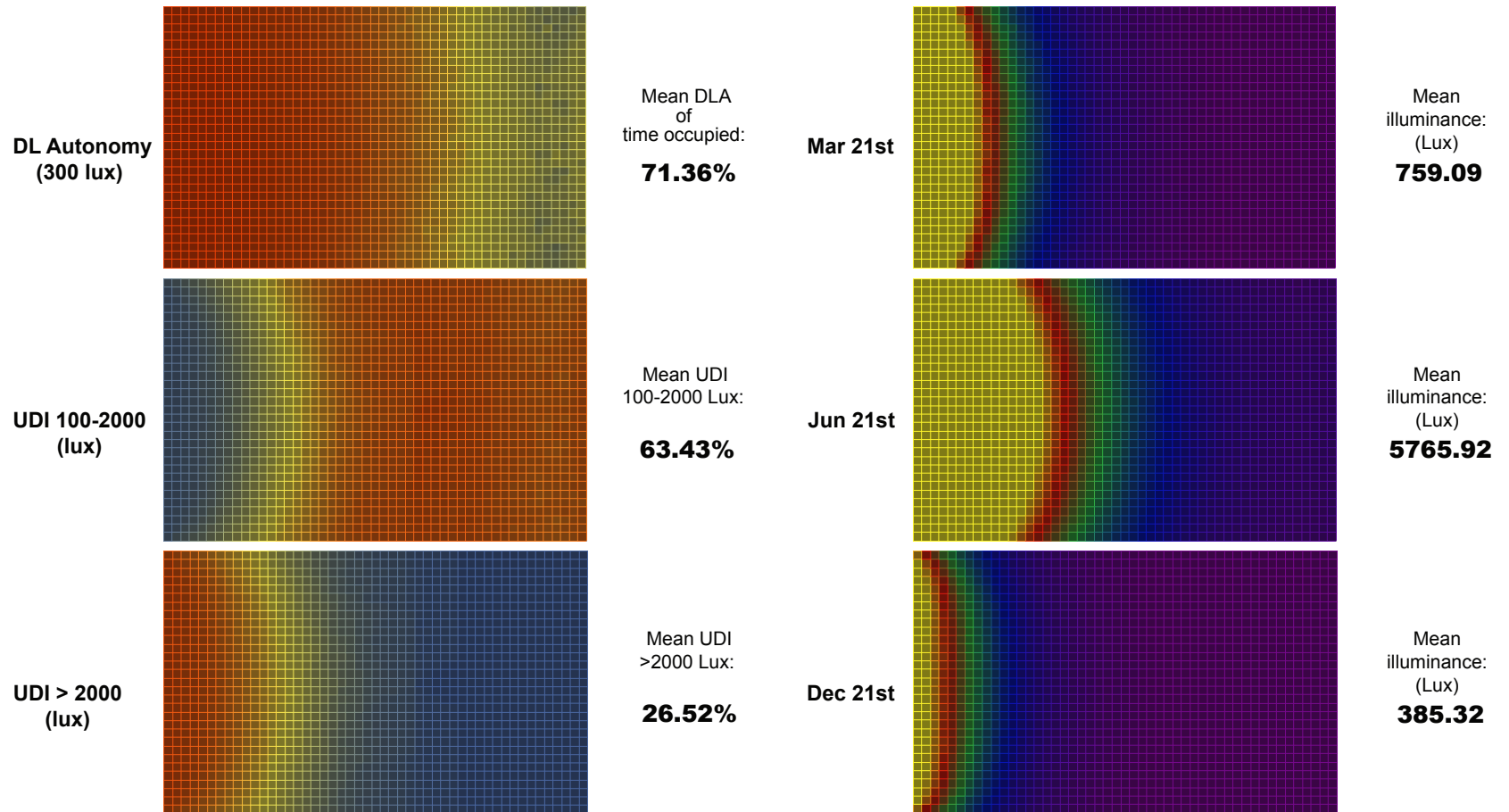
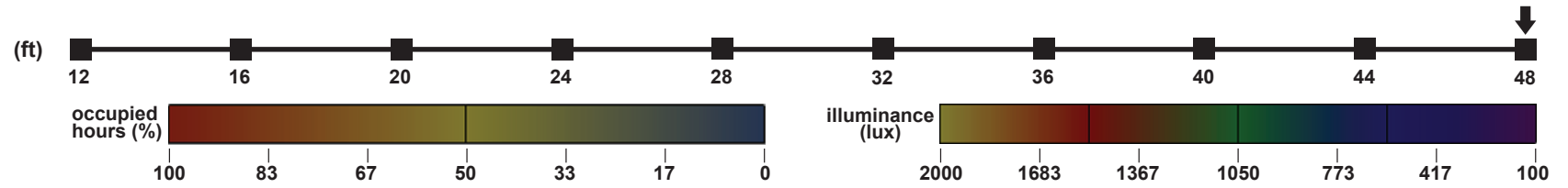

**Appendix B Floor to Ceiling Height Parameter:  
Simulation Results**

Date	Time	Sky Condition
March 21st	12:00	Overcast
Jun 21st	12:00	Clear with Sun
December 21st	12:00	Overcast

Appendix B: Point-in-time illuminance simulation assumptions

# Floor to Ceiling Height:

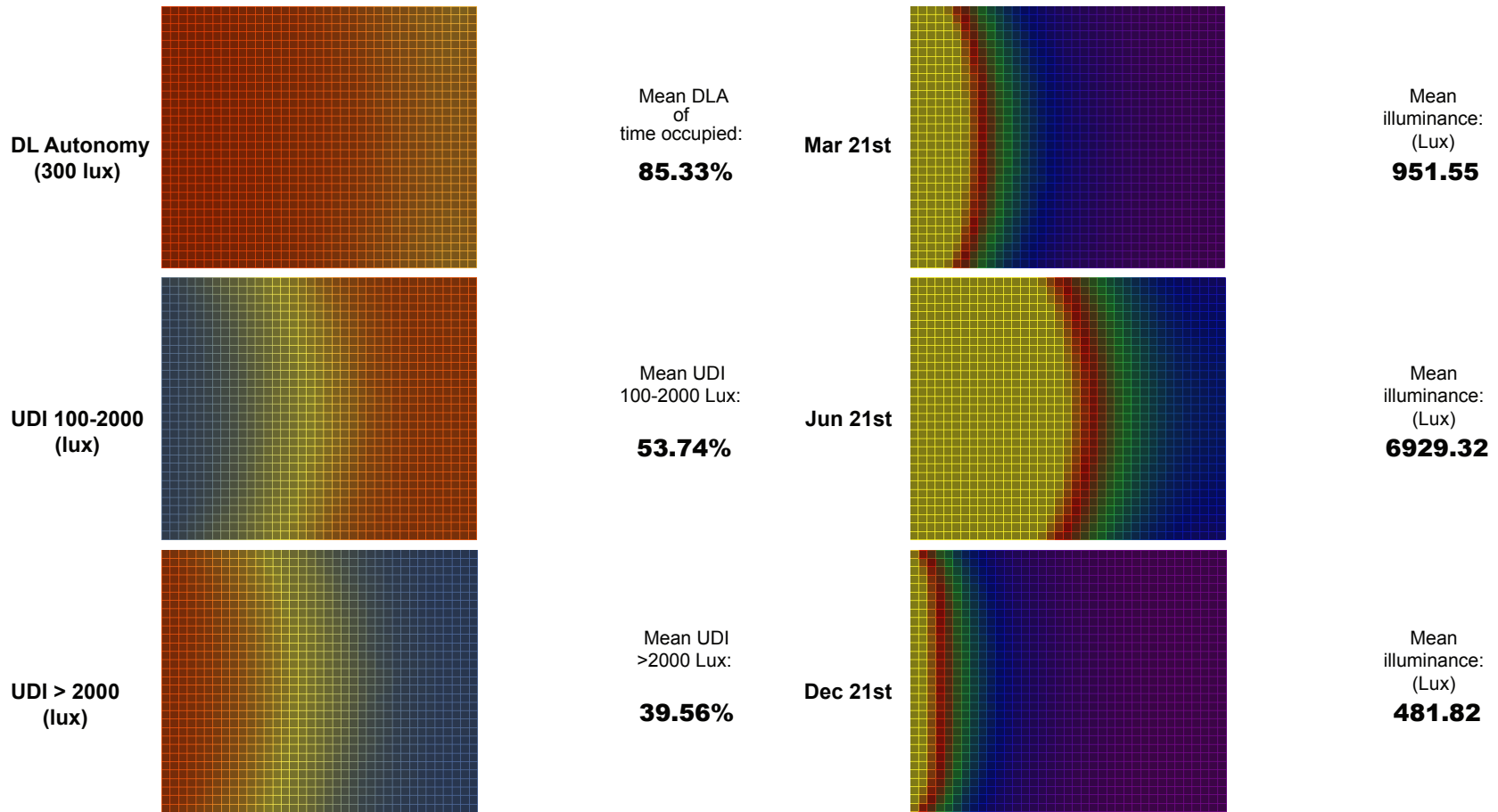
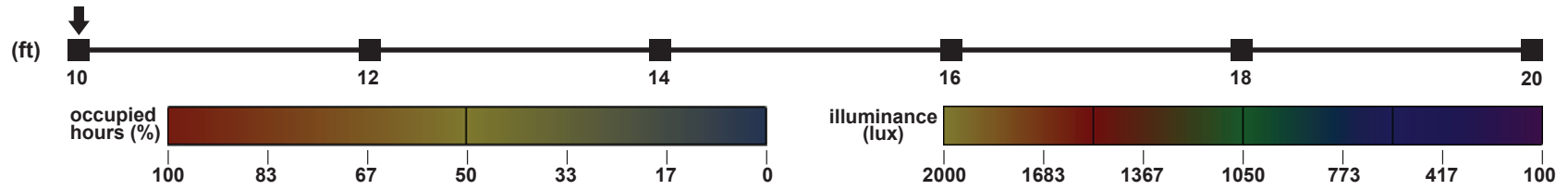

# Floor to Ceiling Height:

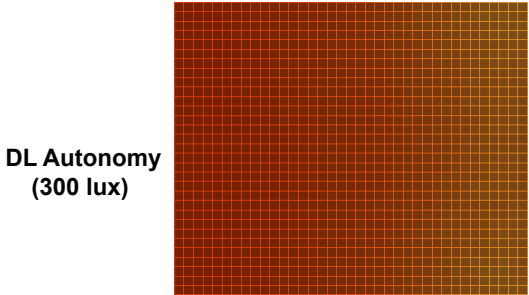
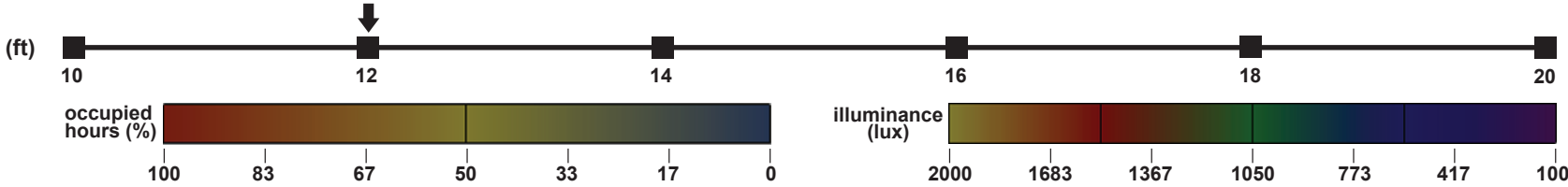

Mean DLA of time occupied: **87.37%**

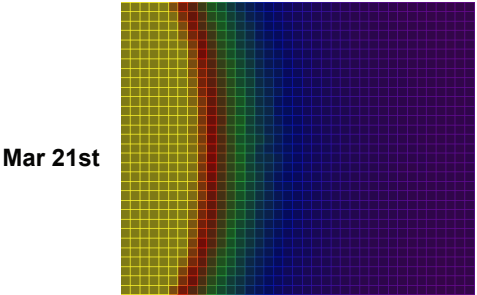

Mean illuminance: (Lux) **1034.59**

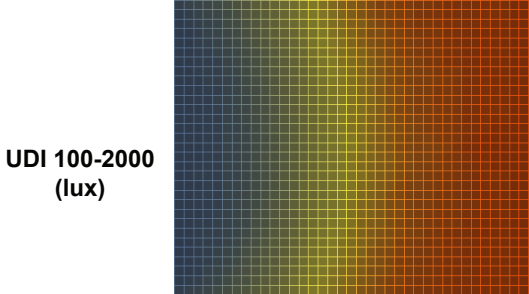

Mean UDI 100-2000 Lux: **52.71%**

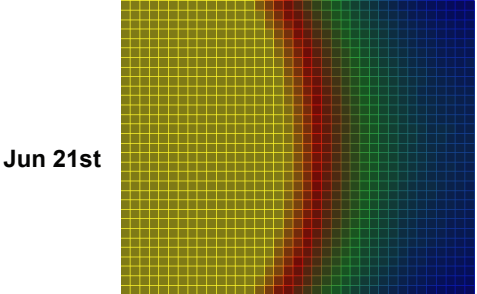

Mean illuminance: (Lux) **7936.16**

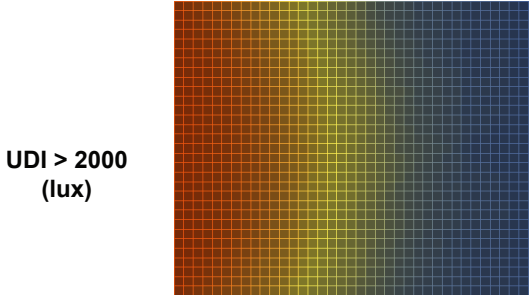

Mean UDI >2000 Lux: **41.00%**

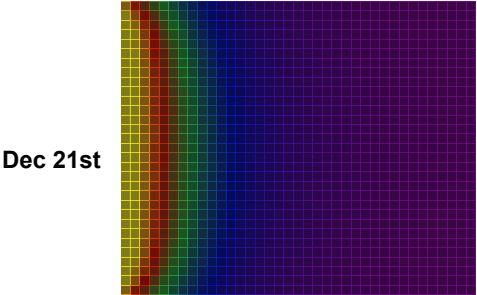

Mean illuminance: (Lux) **525.08**

# Floor to Ceiling Height:

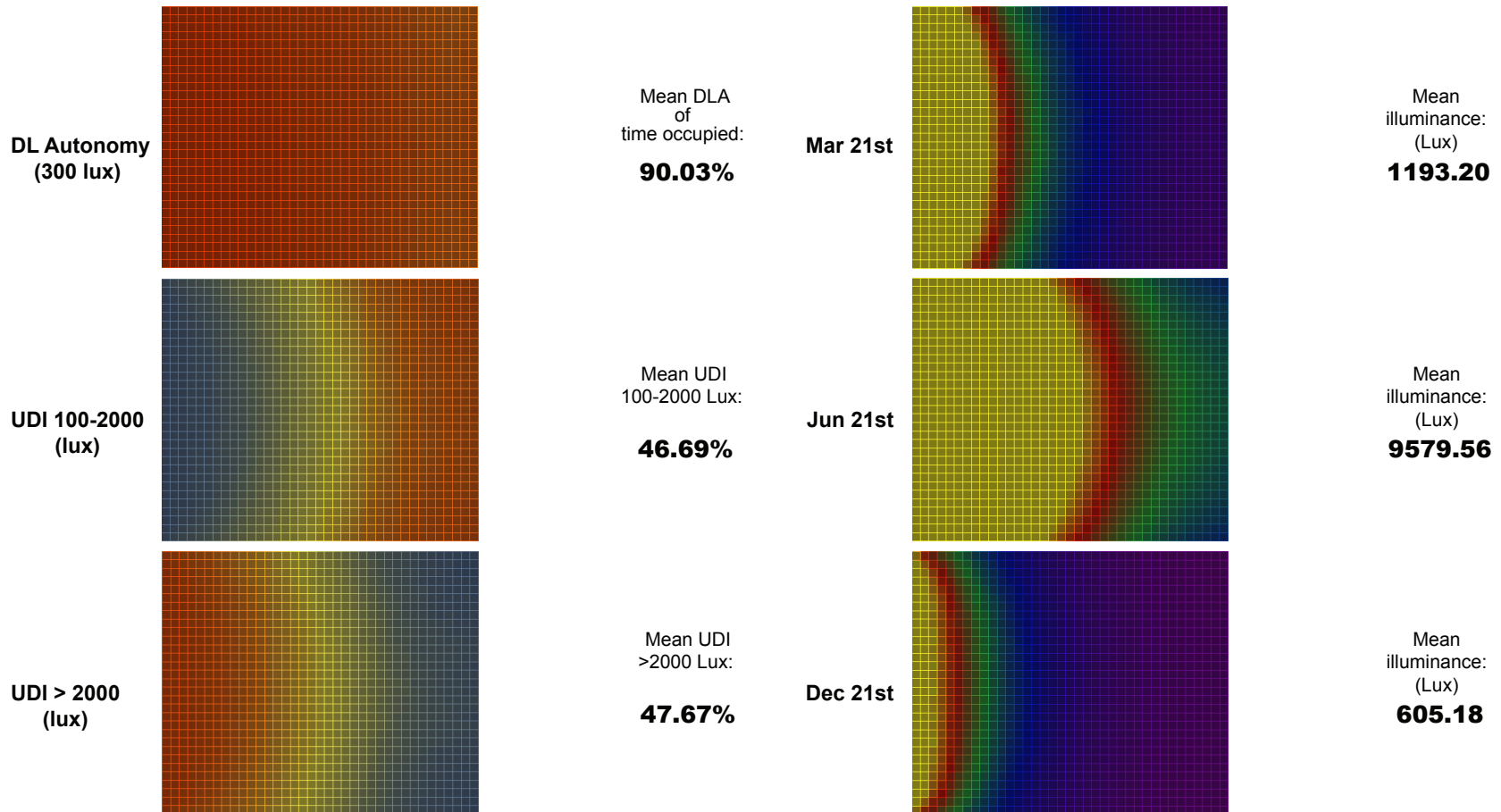
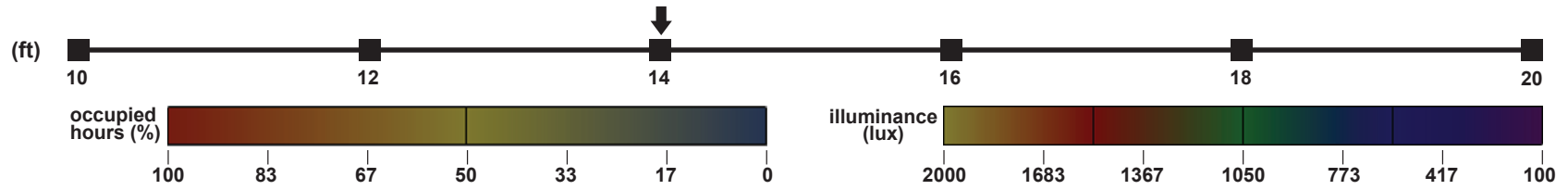

# Floor to Ceiling Height:

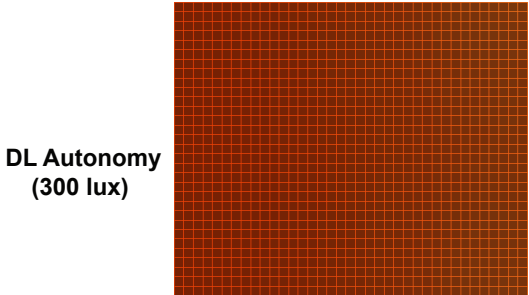
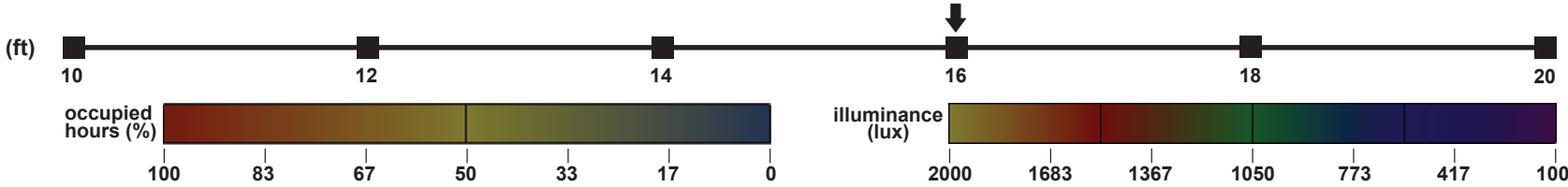

Mean DLA of time occupied: **91.45%**

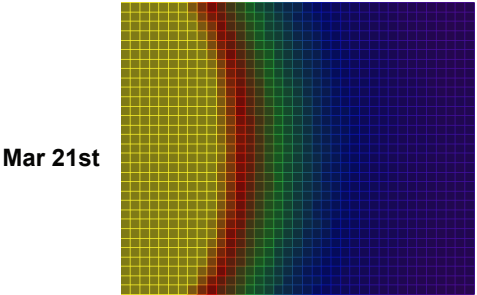

Mean illuminance: (Lux) **1336.02**

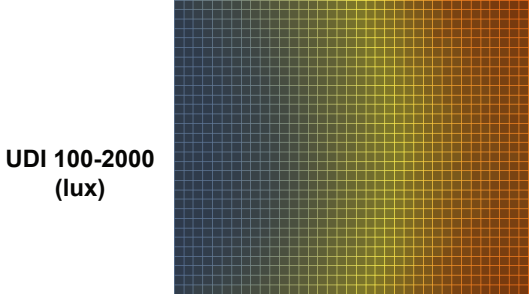

Mean UDI 100-2000 Lux: **41.10%**

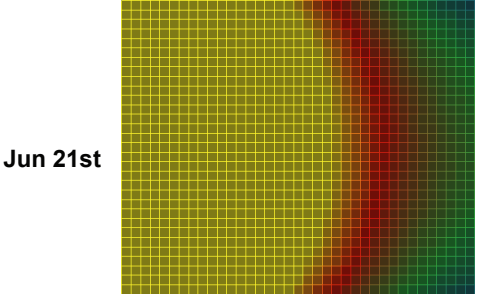

Mean illuminance: (Lux) **11182.9**

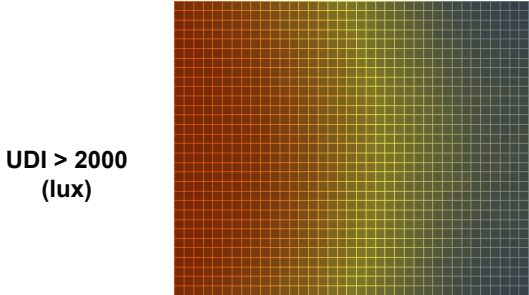

Mean UDI >2000 Lux: **53.64%**

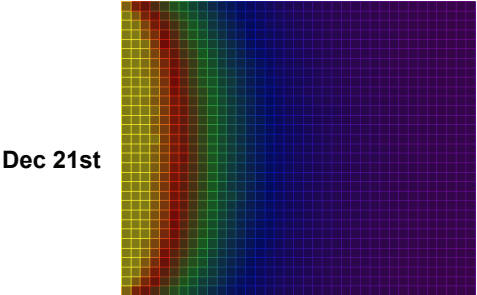

Mean illuminance: (Lux) **676.63**

# Floor to Ceiling Height:

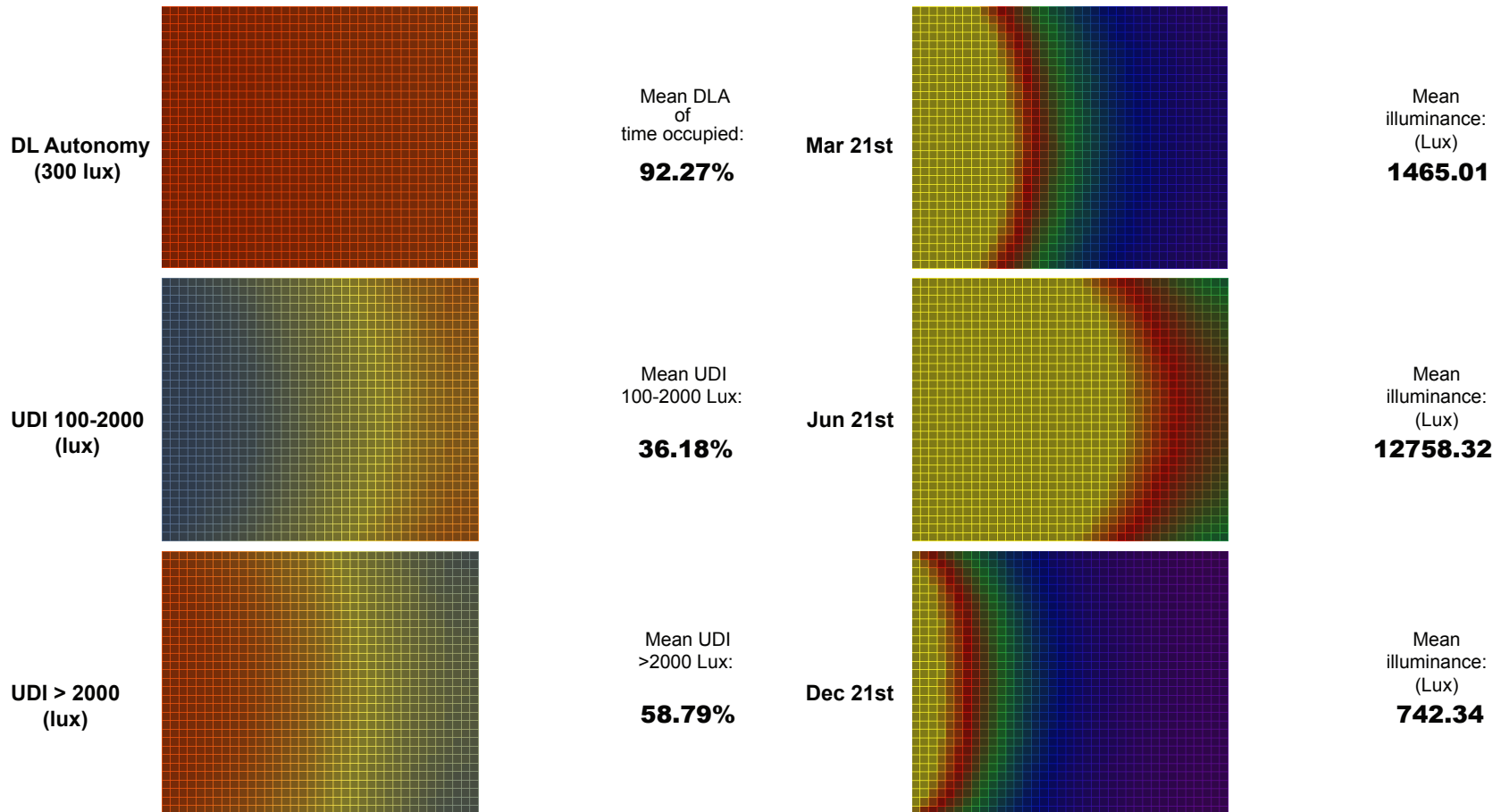
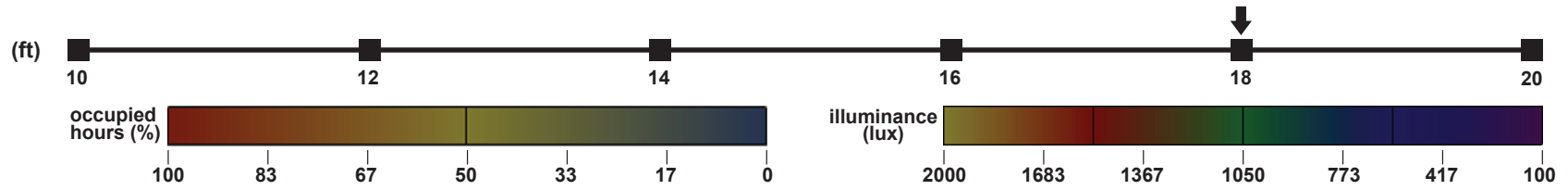

# Floor to Ceiling Height:

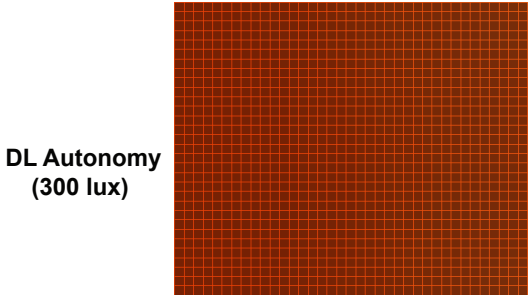
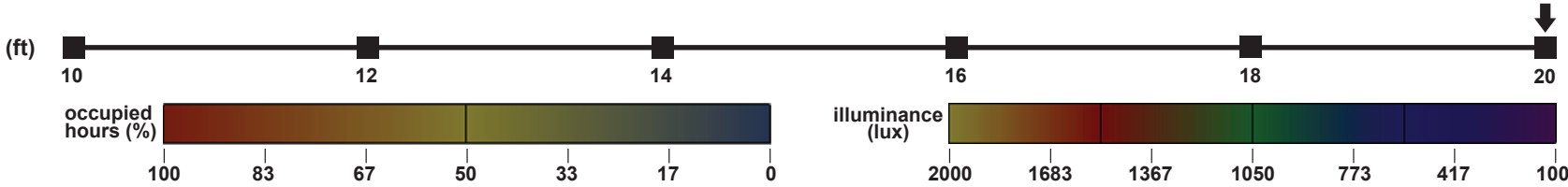

Mean DLA of time occupied: **92.79%**

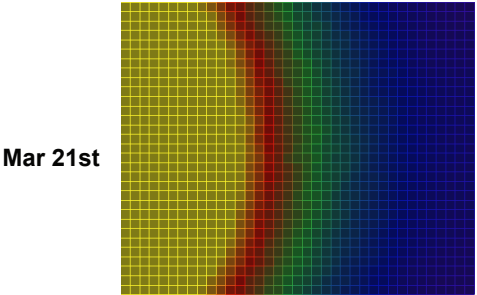

Mean illuminance: (Lux) **1583.79**

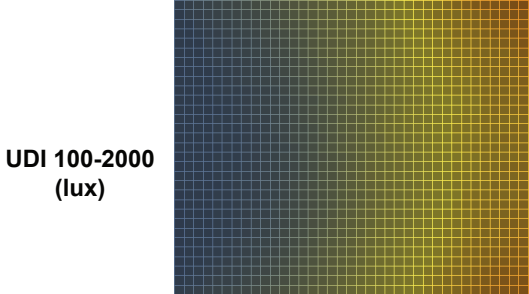

Mean UDI 100-2000 Lux: **32.13%**

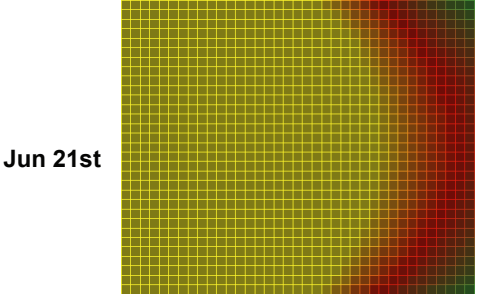

Mean illuminance: (Lux) **14302.32**

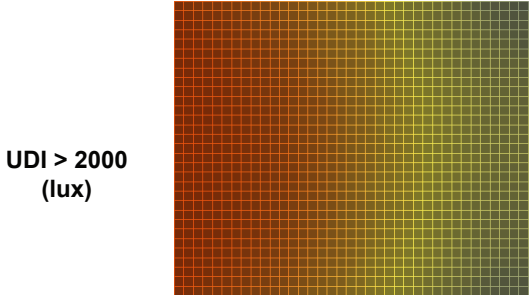

Mean UDI >2000 Lux: **62.98%**

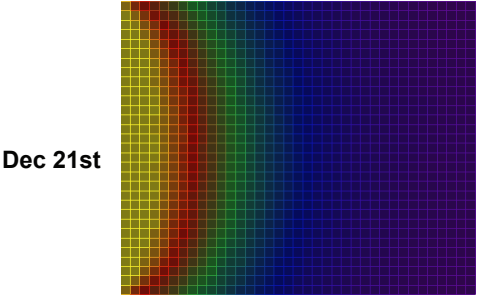

Mean illuminance: (Lux) **802.03**

