

# DSRC/WAVE ENABLED CONNECTED VEHICLES INFRASTRUCTURE

FINAL PROJECT REPORT

by

Sumit Roy  
University of Washington, Seattle

Matching Sponsor: Nokia Research

for

Pacific Northwest Transportation Consortium (PacTrans)  
USDOT University Transportation Center for Federal Region 10  
University of Washington  
More Hall 112, Box 352700  
Seattle, WA 98195-2700

In cooperation with U.S. Department of Transportation,  
Office of the Assistant Secretary for Research and Technology (OST-R)



## **DISCLAIMER**

The contents of this report reflect the views of the authors, who are responsible for the facts and the accuracy of the information presented herein. This document is disseminated under the sponsorship of the U.S. Department of Transportation's University Transportation Centers Program, in the interest of information exchange. The Pacific Northwest Transportation Consortium, the U.S. Government and matching sponsor assume no liability for the contents or use thereof.

## TECHNICAL REPORT DOCUMENTATION PAGE

<b>1. Report No.</b>	<b>2. Government Accession No.</b> 01701510	<b>3. Recipient's Catalog No.</b>	
<b>4. Title and Subtitle</b> DSRC/WAVE ENABLED CONNECTED VEHICLES INFRASTRUCTURE		<b>5. Report Date 8-15-2019</b>	
		<b>6. Performing Organization Code</b>	
<b>7. Author(s) and Affiliations</b> Sumit Roy 0000-0002-3357-4700 Electric and Computer Engineering University of Washington		<b>8. Performing Organization Report No.</b>  2017-S-UW-2	
		<b>9. Performing Organization Name and Address</b> PacTrans Pacific Northwest Transportation Consortium University Transportation Center for Federal Region 10 University of Washington More Hall 112 Seattle, WA 98195-2700	
<b>12. Sponsoring Organization Name and Address</b> United States Department of Transportation Research and Innovative Technology Administration 1200 New Jersey Avenue, SE Washington, DC 20590		<b>10. Work Unit No. (TRAIS)</b>	
		<b>11. Contract or Grant No.</b> 69A3551747110	
		<b>13. Type of Report and Period Covered</b> FINAL SEP 27, 2017- AUG 15, 2019	
		<b>14. Sponsoring Agency Code</b>	
<b>15. Supplementary Notes</b> Report uploaded to: <a href="http://www.pactrans.org">www.pactrans.org</a>			
<b>16. Abstract</b> Connected vehicles enabled through the installation of IEEE WAVE/DSRC standard-compliant radios in vehicles and on roadside units (RSU) that operate on DSRC bands will enable multiple innovations that promote safety and efficiency. An example are is intelligent signalized intersections that allow an RSU at the intersection to obtain real-time information about traffic at intersections. This may reduce the likelihood of collisions and delay through enhanced traffic control means such as broadcasting of suitable warnings or emergency messages. Key to the above is the performance of the 802.11p/WAVE standard, which is based on a design intended largely for <i>low-mobility, single-hop, non delay-critical applications</i> . Many of the protocol stack modifications proposed for the necessary low-latency, potentially multi-hop broadcast remain <i>un- tested</i> in operational scenarios. This effort centered around evaluating DSRC in real-world environments and its potential for integration into a UW PacTrans test-bed for an intelligent signalized intersection.			
<b>17. Key Words</b> Vehicle-to-vehicle communications, vehicle-to-infrastructure communications, vehicular networks, autonomous vehicles			<b>18. Distribution Statement</b>
<b>19. Security Classification (of this report)</b> Unclassified.	<b>20. Security Classification (of this page)</b> Unclassified.	<b>21. No. of Pages</b> 11	<b>22. Price</b> N/A



## TABLE OF CONTENTS

Executive Summary .....	ix
CHAPTER 1: DSRC MESSAGING USING COHDA WIRELESS RADIOS .....	1
1.1. Performance Evaluation .....	4
1.1.1. Experiment 0 (Range Test): .....	4
1.1.2. Experiment 1 (Stationary Test): RSU-OBU Downlink .....	5
CHAPTER 2: VEHICULAR RADAR .....	9
CHAPTER 3. CONCLUDING REMARKS.....	15
3.1 DSRC Using Cohda Wireless Radios .....	15
3.2 Vehicular Radar Imaging .....	15
REFERENCES .....	17

## LIST OF FIGURES

Figure 1.1 DSRC spectrum and channelization.....	1
Figure 1.2 DSRC/WAVE network stack architecture .....	2
Figure 1.3 Cohda Wireless DSRC MK5 onboard and roadside radio units .....	3
Figure 1.4 Aerial view of PACCAR Research and Development Center test track, Mt. Vernon, Washington .....	5
Figure 1.5 Received power on the uplink (OBU to RSU) with the stationary source .....	6
Figure 1.6a Index of WSA sent from the OBU at various points on the drive path.....	7
Figure 1.6b Corresponding received signal power on the uplink as a function of the WSA index .....	7
Figure 2.1: The TI AWR radar board (left) and set-up indoors in the FUNLaB, University of Washington, Seattle .....	10
Figure 2.2: TI MIMO radar evaluation board application programming interface .....	11
Figure 2.3: Radar signal processing workflow .....	11
Figure 2.4: Image of stationary reflector, 14 m from the radar, at the boresight .....	12
Figure 2.5: Image of target moving at a constant velocity toward the radar (approx. 1 m/s), initial position 10 m from the radar, at initial angular position 10 degrees from the boresight .....	13
Figure 2.6: Image of a moving pedestrian, initial distance 7 m from the radar .....	14

## Abbreviations List

BSS	Basic service set
CCH	Control channel
CNN	Convolutional neural network
DSRC	Dedicated short-range communications
FFT	Fast Fourier transform
FMCW	Frequency modulated continuous waveform
GHz	Gigahertz
IPv6	Internet Protocol version 6
LLC	Logical link control
MAC	Medium access control
MHz	Megahertz
MIMO	Multiple-input multiple-output
MLME	MAC Layer Management Entity
OBU	Onboard unit
PLME	Physical Layer Management Entity
RSU	Roadside unit
SCH	Service channels
SDK	Software development kit
RSSI	Received signal strength indicator
TCP	Transmission Control Protocol
UDP	User Datagram Protocol
WAVE	Wireless Access for Vehicular Environments
WME	WAVE Management Entity
WSA	WAVE Service Announcement
WSMP	WAVE Short Message Protocol

## **Acknowledgments**

The author gratefully acknowledges the support of Chris Balton (Principle Engineer, PACCAR Technical Center) for the Cohda Wireless MK5 DSRC devices (the onboard and roadside unit), as well as the necessary software licenses for conduct of the work reported in Year 1.

## EXECUTIVE SUMMARY

The work reported under this two-year effort can be divided into two distinct annual projects, both related to vehicular sensing and networking.

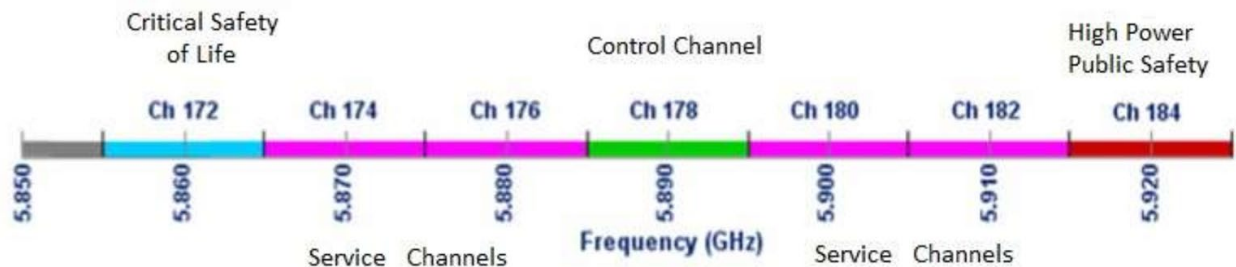
**Year 1:** Courtesy of a PACCAR Technical Center donation of two IEEE 802.11p / Wireless Access for Vehicular Environments (WAVE)-compliant dedicated short-range communications (DSRC) radios (one for onboard a vehicle and one roadside unit for lab testing), we tested WAVE service advertisement within WAVE short message protocol (WSMP) medium access control (MAC) layer messaging to provide robust vehicle-to-infrastructure connectivity on a test track.

**Year 2:** With increasing integration of commercial radar as sensors on vehicles for object localization and ultimately scenario mapping (object recognition), we explored the basic imaging capabilities of a TI 77-Ghz radar unit.

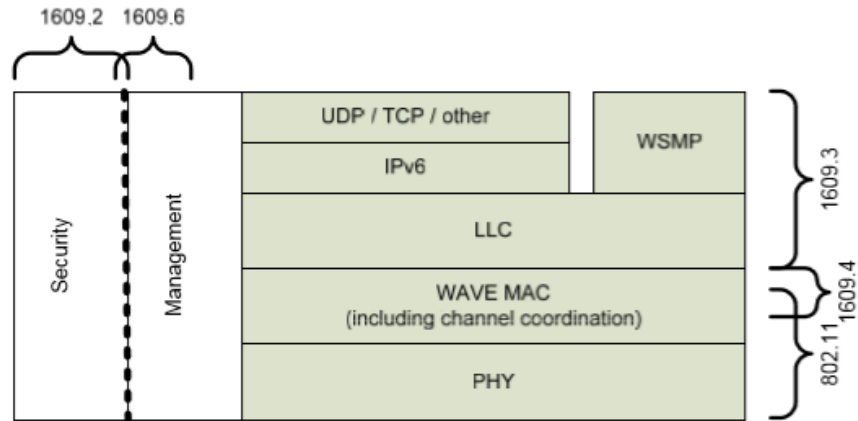


## CHAPTER 1: DSRC MESSAGING USING COHDA WIRELESS RADIOS

Dedicated short-range communications (DSRC)/ Wireless Access for Vehicular Environments (WAVE) is a standardized protocol stack suite intended for use in vehicular environments [1, 2], i.e., for vehicle-to-vehicle (v2v) and vehicle-to-infrastructure (v2I) communications, broadened to include v2X (vehicle-to-everything) communication. DSRC is based on IEEE 802.11p (an amendment of the 802.11 stack) that standardizes the physical (PHY) and medium access control (MAC) layers and in North America is assigned the 5.85- to 5.925-GHz band. The 75 MHz are divided into seven 10-MHz channels, with a 5-MHz guard band (figure 1.1). The DSRC standard was adopted by the IEEE 1609 Family of Standards for Wireless Access in Vehicular Environments (WAVE), which defines the architecture, communications model, management structure, security mechanisms, and physical access for high speed (up to 27 Mb/s), short range (up to 1000 m), low latency wireless communications in the vehicular environment.



**Figure 1.1:** DSRC spectrum and channelization



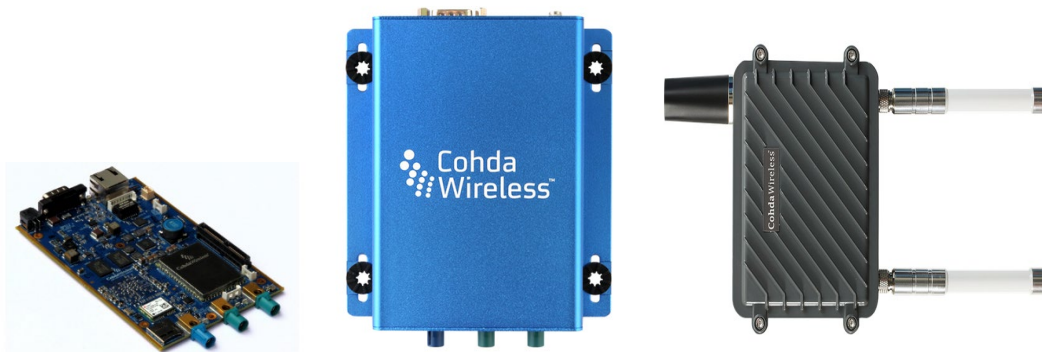
**Figure 1.2:** DSRC/WAVE network stack architecture

The IEEE 802.11p PHY layer takes care of modulation/demodulation, error correction technique, etc. The 10-MHz channels are of two types: one control channel (CCH) and six service channels (SCH). CCH is the default channel for common safety communications. The two channels at the ends of the spectrum band are reserved for special uses. The rest are service channels available for both safety and non-safety use. Advertisement messages are broadcast over the CCH to provide information about which services are currently available on which service channels, so that radios can tune to a service channel. The DSRC onboard unit (OBU), by default, is tuned to the CCH to send and receive safety messages continuously. If the OBU is engaged in some non-safety application communications in a SCH, then it is expected to actively switch between CCH and SCH channels for the duration of the service session. The IEEE 802.11p MAC layer transports messages to establish and maintain connection in the vehicular environment. Stations communicate directly without the need to communicate or join a basic service set (BSS) in 802.11p.

The upper layers are defined by IEEE 1609 and are divided into a management plane and data plane. The management plane consists of the WAVE Management Entity (WME), MAC

layer Management Entity (MLME), and Physical Layer Management Entity (PLME), The data plane consists of the WAVE Short Message Protocol (WSMP), Transmission Control Protocol (TCP), User Datagram Protocol (UDP), Internet Protocol version 6 (IPV6), logical link control (LLC), MAC, and PHY layers. Within the management plane, 1609.4 handles timing synchronization, controlling channel access, the transmission and reception of Vendor Specific Action frames, and maintenance of the Management Information Base.

We acquired Cohda wireless MK5 DSRC units (see figure 1.3) [4] that were DSRC/Wave compliant: an OBU for mounting on the vehicle and a roadside unit (RSU) to be part of the infrastructure. Cohda also provided a software development kit (SDK) and example programs for the 1609 and European Telecommunications Standards Institute (ETSI) applications within a Linux environment. The 802.11p boards also included Global Navigation Satellite System (GNSS), dual-core ARM, and a 1-GB RAM. The OBU was equipped with Ethernet, USB, GPI, CAN, and a 7- to 12-V power supply, while the RSU got power over Ethernet



**Figure 1.3:** Cohda wireless DSRC MK5 onboard and roadside radio units

WAVE systems use an efficient messaging protocol known as WAVE Short Message Protocol (WSMP) for time-sensitive, high-priority frames sent directly over the control channel.

### 1.1. Performance Evaluation

After initial lab testing, the final equipment testing was conducted at the PACCAR facility, shown in figure 1.4 (Mt Vernon, Washington).

#### 1.1.1. *Experiment 0 (Range Test):*

1. The objective was to find the minimum received signal strength indicator (RSSI) for which a packet was successfully decoded by the OBU.
2. The RSU and OBU were placed close to each other.
3. The RSU was configured to transmit packets at the minimum rate and default transmission power by using the pre-compiled binaries.
4. The separation of OBU and RSU was slowly increased until no packets were being decoded. The lowest RSSI value was recorded in the log.
5. The above steps were repeated for different rates and the minimum RSSI values were reported for each run.



**Figure 1.4:** Aerial view of PACCAR Research and Development Center test track, Mt. Vernon, Washington.

X: marks the location of installed RSUs that formed a backhaul wireless mesh for mobile on-track vehicles for connecting to the core wired backbone.

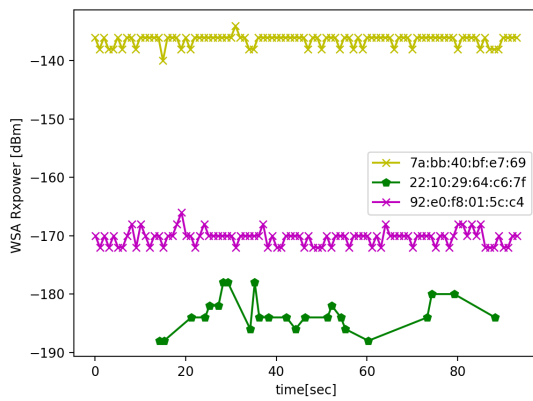
1.1.2. *Experiment 1 (Stationary Test): RSU-OBU Downlink*

1. The vehicle mounted with the OBU was stopped at any point on the track.
2. One by one each RSU was turned on and made to transmit  $n$  packets at the lowest rate possible at the default power (done with the help of pre-compiled programs that came with the Cohda Wireless SDK).
3. At the OBU, the companion program received and logged all the packets, along with the RSSI data.
4. The transmitting RSU was turned off and the next RSU was switched on, and steps 1 through 3 were repeated and the log file saved.
5. Once data from all the RSUs had been collected, the GPS positions of different RSUs and OBU were logged to calculate the distance between every RSU and the OBU.
6. The average RSSI from every RSU to the OBU was calculated and was mapped to the distance values calculated in the previous step.
7. The vehicle was moved to a different spot on the track, and steps 1 through 6 were repeated.
8. The result of the above procedure produced an RSSI vs distance graph useful for planning the placement of RSU nodes for desired reliability and coverage.

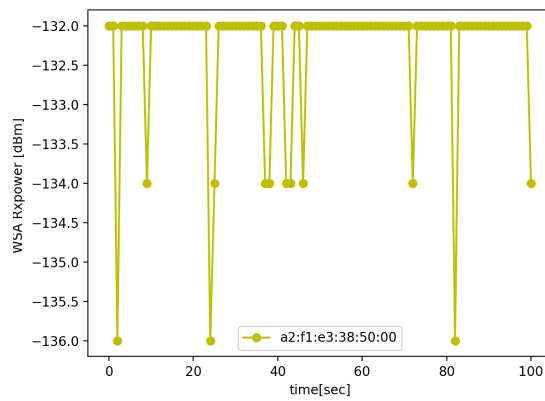
Initial testing showed that a high throughput was obtained with a stationary vehicle, but while a vehicle was in motion, connectivity was compromised. This was interpreted as a failure of the handoff when the vehicle moved from the coverage zone of one RSU to the next. The primary goals of the project were to solve this handoff issue and demonstrate a persistent network connection between an OBU and an RSU while in motion.

Accordingly, the new experiment design was based on the OBUs continually sending a WAVE Service Announcement (WSA) within WSMP messages to the RSUs via a Cohda SDK example program. Tcpdump was installed and used on the OBU to test the performance of WSMP reception in both the stationary and dynamic tests. The results are shown below.

### Stationary Test 1

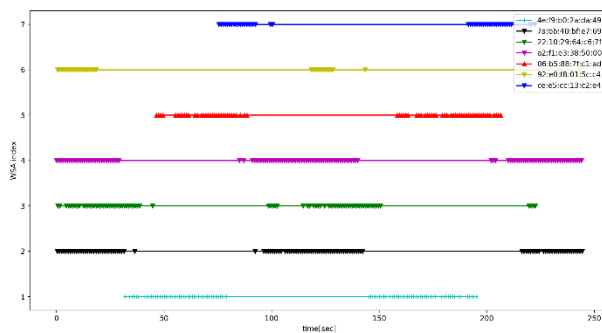


### Stationary Test 2

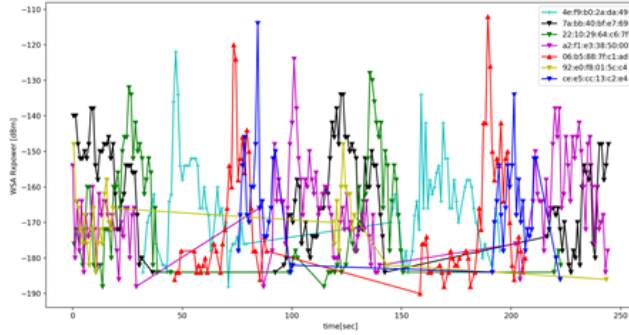


**Figure 1.5:** Received power on uplink (OBU to RSU) with a stationary source.

### Dynamic Test 1



**Figure 1.6a:** Index of WSA sent from the OBU at various points on the drive path (function of time)



**Figure 1.6b:** Corresponding received signal power on uplink as a function of the WSA index.

The conclusion was that through use of the WSA in WSMP messaging, the OBU maintained a continuous connection with the RSUs (albeit with varying link rates, as expected) for the duration of the track. That is, at no point was connectivity lost.



## CHAPTER 2: VEHICULAR RADAR

Radar is a powerful sensor technology that provides all-weather operation with low cost and proven reliability in vehicular (high relative speed) environments. A known challenge related to using radar returns from desired objects is the presence of multipaths from extended targets that result in target scintillation/fading with motion. As a result, advanced digital signal/image processing techniques are needed to improve the reliability of detection (both false positives and negatives are of concern) and estimation of target properties. This effort represented an initial exploration of the ability of a commercially available 77-GHz radar platform to detect objects and create maps of the environment surrounding a source vehicle, including moving and stationary objects.

We acquired a *single-chip automotive multiple-input multiple-output (MIMO) radar evaluation board from Texas Instruments*, the TI AWR1642 Boost, that supported up to three Tx and four Rx MIMO (figure 2.1) in the 77- to 81-GHz band [5]. The TI evaluation board could be connected to a data capture card to save the received I-Q data to a personal computer for post-processing. A test-bed platform was set up in researchers' laboratory (<https://depts.washington.edu/funlab>) with the board and corner reflectors as control targets to conduct preliminary tests in an indoor setting. In typical usage, multiple radars were mounted on a vehicle, including both forward/backward and sideways sensors for front/back/side object detection and localization/tracking with updates at a 100-ms rate. The desired front/back operating range was 20 m (short) to 200 m (long), for frequency modulated continuous waveform (FMCW) modulation<sup>1</sup>, which is achieving significant market penetration because of

---

<sup>1</sup> Note that the full-duplex capability of FMCW radars – i.e., an ability to process/detect target returns *while* a chirp is being transmitted – is fundamental to its adoption in automotive applications; this is necessary for range resolution at

its potential for offering enhanced performance features at a reasonable cost. The AWR 1642 Boost was demonstrated a range of approximately 80 m.

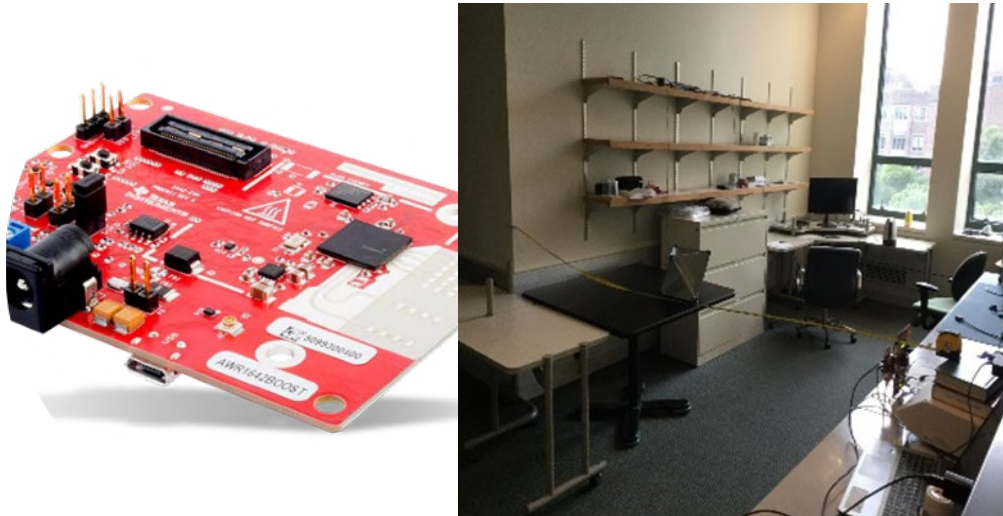


Figure 2.1: The TI AWR radar board (left) and set-up indoors in the Fundamentals of Networking Laboratory (FUNLaB), Department of Electrical and Computer Engineering, University of Washington, Seattle.

The application programming interface for the 77-GHz radar board allowed users to change the FMCW waveform parameters for experimentation (chirp slope, duration, coding), as shown in figure 2.2. The acquired data were post-processed for radar detection/imaging by using a conventional 2-D fast Fourier transform (FFT) and short-term-FFT of the sampled I-Q data. The preliminary results reported below verified the hardware and software functionalities. A full signal processing flowchart using Matlab is shown in figure 2.3; note that only the results of range-velocity and range-angle processing blocks are shown.

---

near distances. This is distinct from traditional higher-power radars that seek to detect objects at *far* distances, which have used RF *pulses* in half-duplex mode.

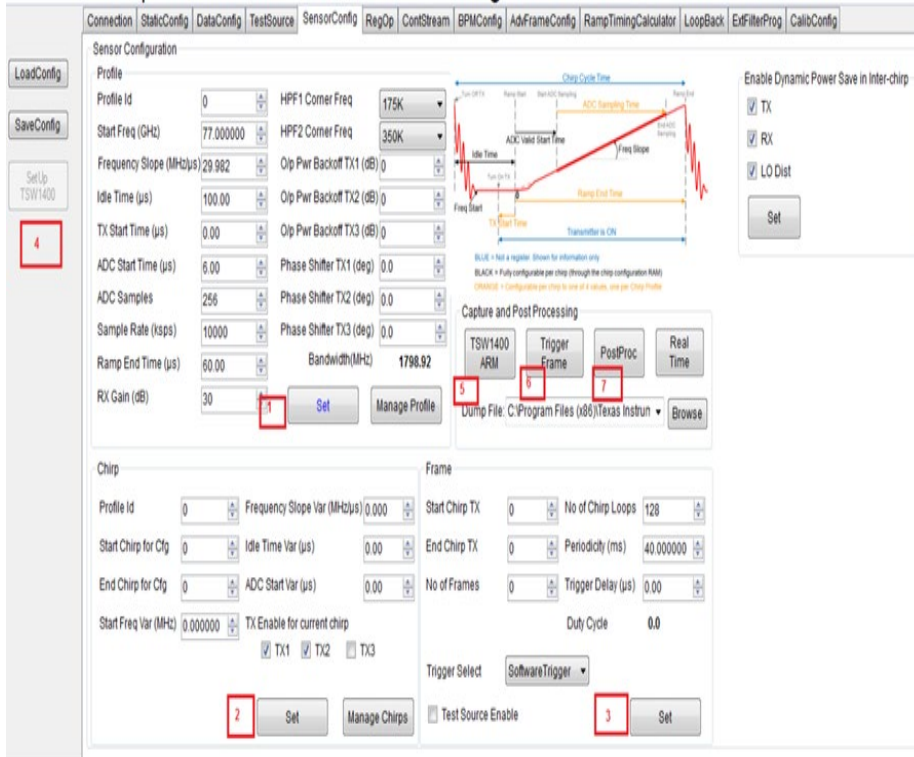


Figure 2.2: TI MIMO radar evaluation board application programming interface

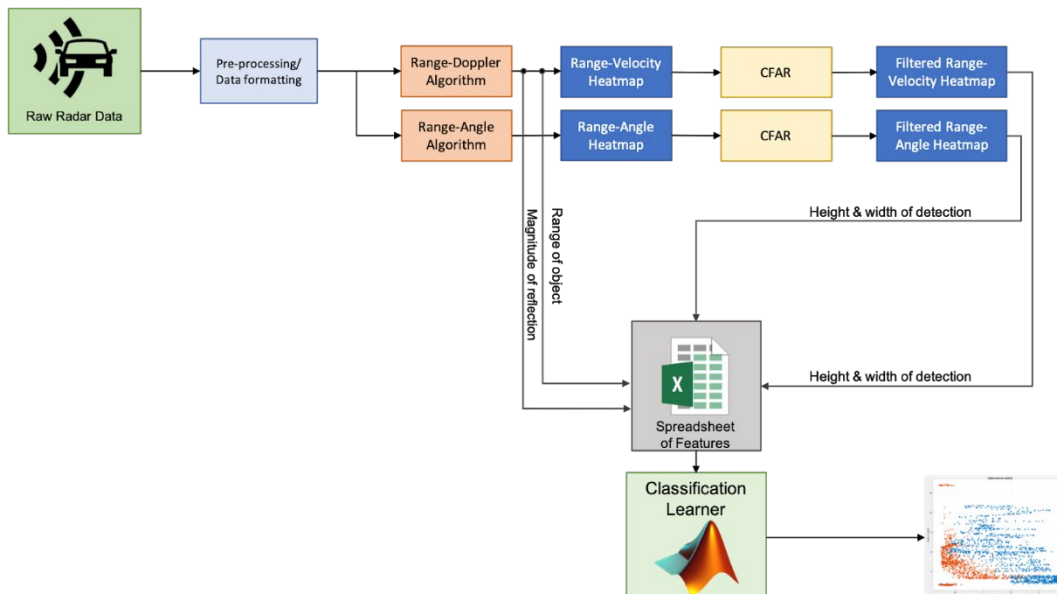


Figure 2.3: Radar signal processing workflow

The results validated the signal processing methodology; for example, the canonical point stationary target in figure 2.4 shows as zero-Doppler on the range-Doppler map, whereas a target moving toward the radar (figure 2.5) registers as a shift. The latter target is also offset from the boresight, as expected. More interesting features were seen for extended targets, such as the pedestrian in figure 2.6, indicating both the promise and challenges of differentiate such objects from other classes (e.g., pedestrian versus vehicles of various types) on the basis of their respective features, as seen in such images.

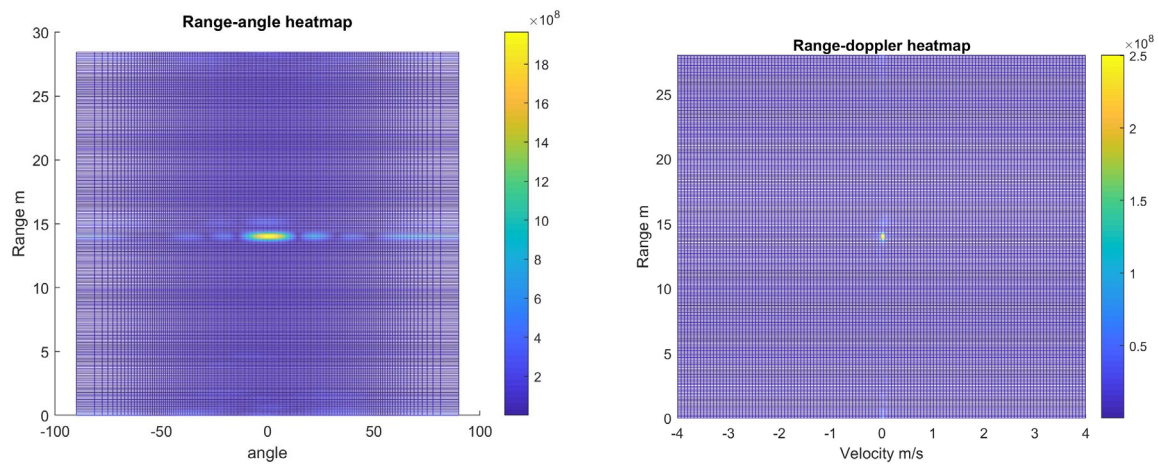


Figure 2.4: Image of stationary reflector, 14 m from the radar, at the boresight.

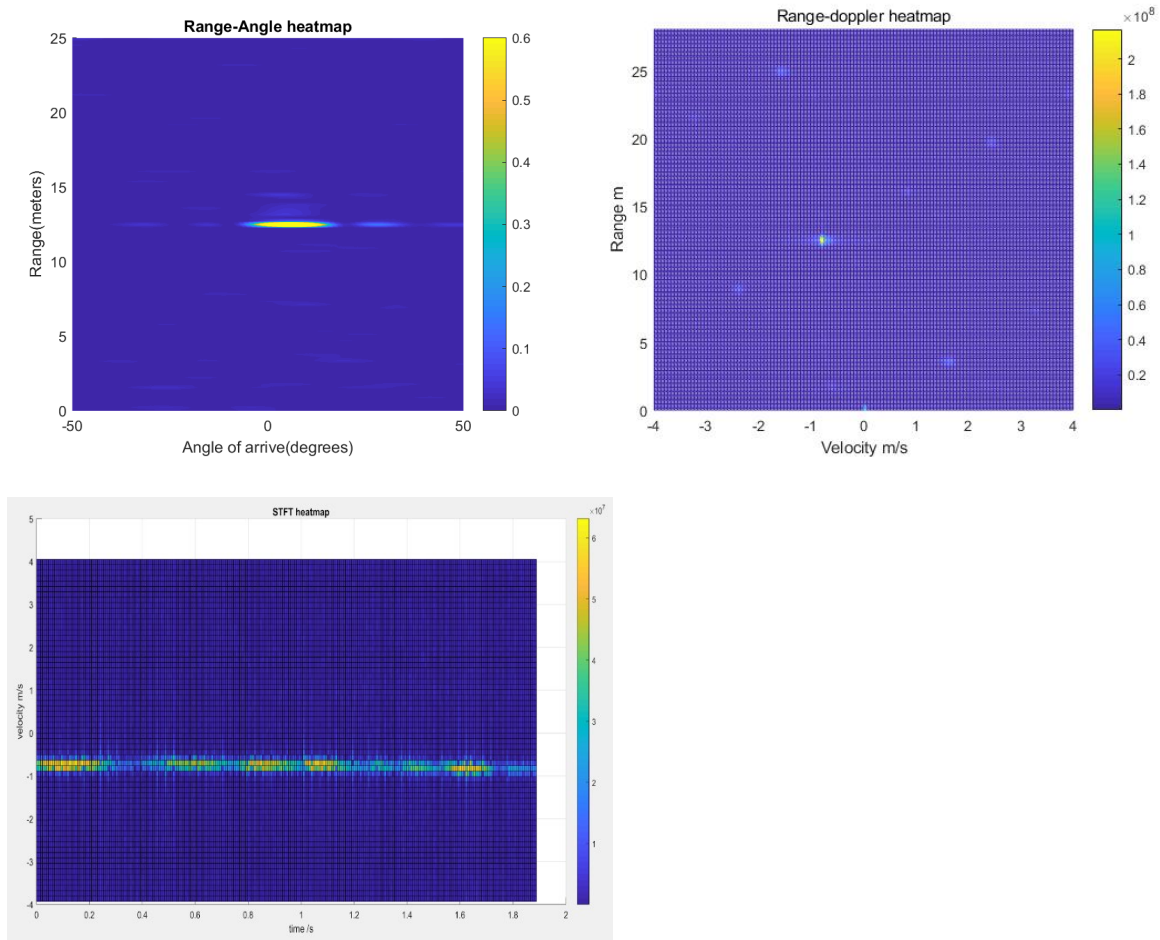


Figure 2.5: Image of moving target at a constant velocity toward the radar (approximately 1 m/s), initial position 10 m from the radar, at an initial angular position of 10 degrees from the boresight.

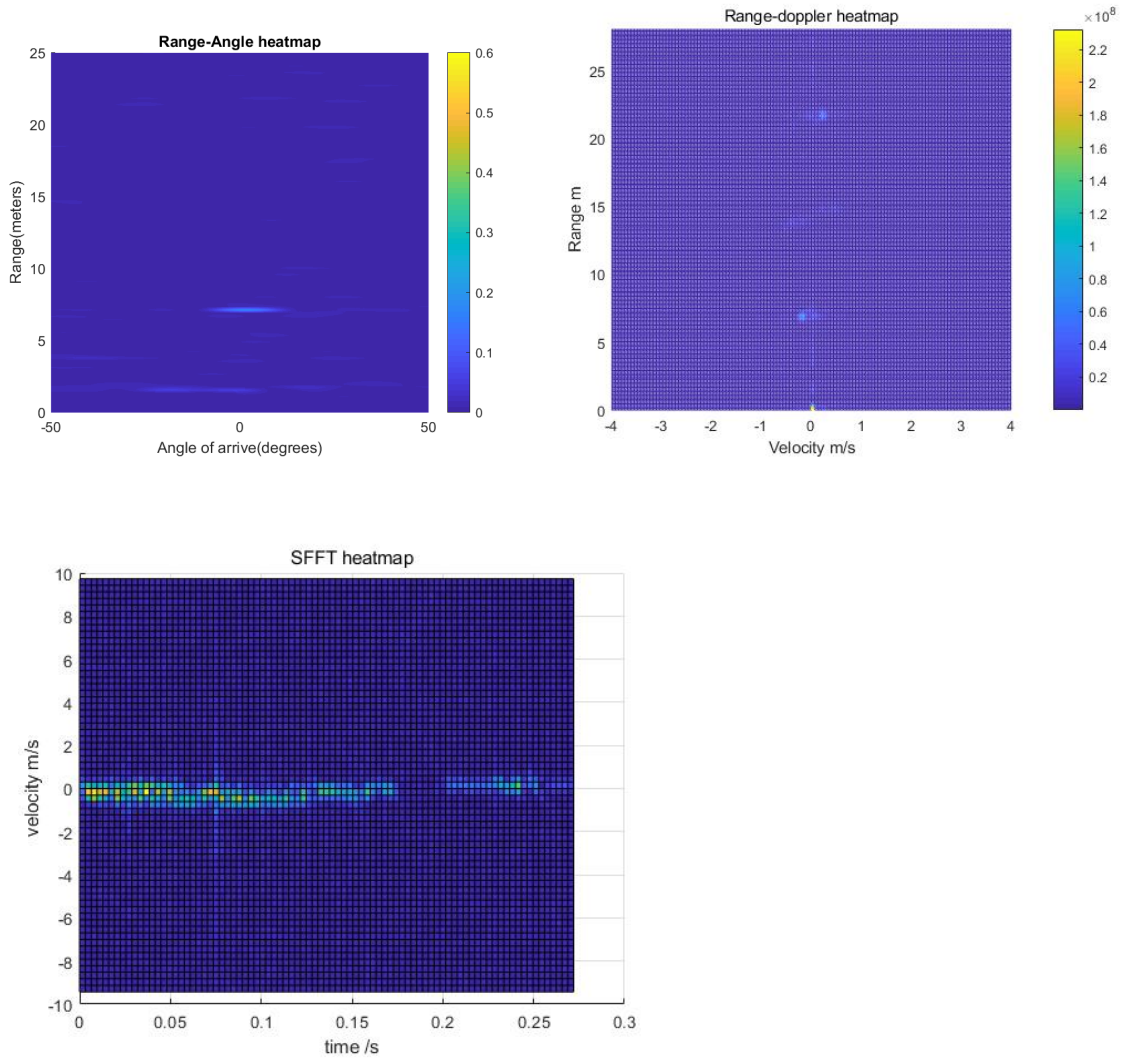


Figure 2.6: Image of moving pedestrian, initial distance 7 m from the radar

## CHAPTER 3. CONCLUDING REMARKS

### 3.1 DSRC Using Cohda Wireless Radios

The primary objective of this effort was to test the quality of the physical layer connection between an OBU and RSU for link bandwidth and reliability at the PTC. The test data confirmed that the vehicle OBU remained in range, i.e., connected to na RSU, at all locations around the track (static testing). However, testing for mobility was limited, and the conclusions are incomplete; our data showed significant hand-off failures between RSUs. These initial results confirmed the general expert consensus that DSRC needs improvements at both the link and network layers to achieve desired levels of robustness and QoS metrics. For example, Wu et al. [8] recommended that achieving high and reliable performance in highly mobile, often densely populated, and frequently non-line-of-sight environments would require enhancing the radio layer with better channel codes and interleaving adapted to short packets for dissemination of emergency messages. A more complete study by Demmel et al. [9] remarked that, “frame loss remains manageable over most of the range but is quite dependent on environmental conditions. Our results are more pessimistic than existing literature.” A particular issue of concern is the diminishing of effective transmission range caused by relative mobility, and “a vehicle driving past an RSU would be able to maintain connectivity for only 800 m.”

### 3.2 Vehicular Radar Imaging

Exploration of the imaging/object recognition capabilities of the TI 77-GHz MIMO radar continues, and a more detailed report has subsequently been published by Gao et al. [10]. Such radars are being increasingly integrated into commercial vehicles in support of adaptive driver assisted systems (ADAS), because of their ability to provide high accuracy object localization (location, velocity, and angle estimates), largely independent of environmental conditions. A large image data set was collected for pre-processing of the radar image data before input into a

convolutional neural network (CNN) configured for efficient object recognition/classification. Our current work involves extensive training and testing of CNN with the acquired data set to determine performance in terms of the accepted metrics of average recall and precision.

## REFERENCES

1. IEEE 1609.0 Standard, "Wireless Access in Vehicular Environments (WAVE) in 5.9 GHz," 2013.
2. IEEE 802.11a, "Wireless LAN MAC and PHY Layer Specifications: High Speed Physical Layer in 5 GHz Band," 1999.
3. Cohda Wireless White Papers on DSRC <https://cohdawireless.com/solutions/white-papers/>
4. Cohda Wireless v2x solutions- MK5 radios <https://cohdawireless.com/sectors/v2x/>
5. Texas Instruments, "MIMO Radar", July 2018  
<http://www.ti.com/lit/an/swra554a/swra554a.pdf>
6. J-J. Lin, Y-P. Li, W-C. Hsu and T-S. Lee, "Design of FMCW Radar Baseband Signal Processing System for Automotive Application," Springer Plus, 2016.
7. S. M. Patole, M. Torlak, D. Wang and M. Ali, "Automotive radars: A review of signal processing techniques," in IEEE Signal Processing Magazine, vol. 34, no. 2, pp. 22-35, March 2017.
8. X. Wu, S. Subramanian, R. Guha, R. G. White, J. Li, K. Lu, A. Bucceri and T. Zhang, "Vehicular Communications using DSRC: Challenges, Enhancements and Evolution," IEEE J. Sel. Areas. Comm., Sep. 2013.
9. S. Demmel, A. Lambert, D. Gruyer, A. Rakotonirainy and E. Monacelli, "Empirical IEEE 802.11p performance evaluation on test tracks," Intelligent Veh. Symp., 2012.
10. X. Gao, G. Xing, S. Roy and H. Liu, "Overview of Automotive Radar Test-bed at U. Washington, Proc. Asilomar *Conf.*, Pacific Grove, CA, Nov. 2019.