

Timber Two: Wood Innovation on the Olympic Peninsula

Weston Summers Norwood

A thesis in partial fulfillment of the requirements  
for the degree of:

Master of Architecture

University of Washington

2016

Chairs of the Supervisory Committee:

Gundula Proksch

Brian McLaren

Program authorized to offer degree:

Architecture

© Copyright 2016

*Weston Summers Norwood*

University of Washington

**Abstract**

Timber Two: Wood Innovation on the Olympic Peninsula

Weston Summers Norwood

Chairs of the Supervisory Committee:

Associate Professor Gundula Proksch

Associate Professor Brian McLaren

Architecture

Washington's Olympic Peninsula evokes images of remote, snow-covered peaks, ancient forests, and rugged cliffs rising out of the Pacific Ocean. The region, celebrated for its natural beauty, has an identity equally rooted in the timber industry, yet there is a disconnect between the public's awe and enjoyment of nature, and their ability to visualize the impact that natural resource extraction has on the Pacific Northwest's changing landscape. The West End of the Olympic Peninsula and Forks are inextricably linked to this dichotomy. The region is home to a bastion of thriving ecologies, yet it is the abundant provider of a natural resource that fuels the growth of cities and enables modern lifestyle. This thesis proposes a new approach to the timber industry, one in which the manufacturing of engineered wood products can help bring new life to the forest communities of the Pacific Northwest. This proposal aims to strike a balance between the demands of the construction industry, the needs of forest communities, and the health and stability of the region's ecosystems. The design of the proposed CLT production facility and Center for Wood Innovation will be located on the site of the recently defunct Interfor mill near Forks, Washington. The thesis will explore how architecture can support and express the functions of production, collaboration, and education on this site, and how such a facility could act as a bridge between resource extraction and the surrounding landscape.

*\* This document is best viewed as a two-page spread.*

# Acknowledgments

---

I would like to thank Louisa Larocci, Gundula Proksch, Rick Mohler, and Brian McLaren for their continual encouragement and insight through the thesis process.

My thanks to Kathrina Simonen for instilling a love of CLT, and sparking the idea to weave education and production together. To Rod Fleck, whose official title as the City Attorney for the Town of Forks does little justice to the twenty hats he wears and his dedication to the community.

Many thanks to my classmates for all they taught me, and for the many shared experiences along the way.

And finally my unending gratitude to my loving and supportive family. Though you are 1,500 miles away, you've shaped me into the person I am, and your love and support mean the world to me.



# Table of Contents

---

Chapter 1 - Introduction	8
Chapter 2 - A Proposal for a New Path Forward	12
<i>A Confluence of Resources: the Forests &amp; the People of Forks</i>	12
<i>A New Material in the Pacific Northwest</i>	28
<i>The Panel</i>	29
<i>Growing Acceptance and Excitement</i>	32
<i>A CLT Facility</i>	34
<i>Current Regional Manufacturers of CLT</i>	36
Chapter 3 - Site Strategies & Programming	38
<i>Why Forks</i>	38
<i>Site Selection Criteria</i>	40
<i>Site Analysis</i>	42
<i>Site Plan and Strategy</i>	46
<i>The Experimental Forest</i>	48
<i>Production Facility Layout</i>	50
<i>The Prairie</i>	53
Chapter 4 - The West End Center for Wood Innovation	56
<i>The Prairie</i>	57
<i>Building Organization</i>	58
<i>Spatial Order in Plan</i>	64
<i>Spatial Sequence</i>	66
Chapter 5 - Conclusions	74
Works Cited	76
List of Figures	78

---

## Introduction

Washington's Olympic Peninsula evokes images of remote, snow-covered peaks, ancient forests, lush prairies, and rugged cliffs rising out of the Pacific Ocean. The region, celebrated for its natural beauty, has an identity equally rooted in the timber industry, however, there is a disconnect between the public's awe and enjoyment of nature, and their ability to visualize the impact that natural resource extraction has on the Pacific Northwest's changing landscape. The West End of the Olympic Peninsula and the town of Forks are inextricably linked to this dichotomy. The region is home to a bastion of thriving ecologies, yet it is the abundant provider of a natural resource that fuels the growth of cities and enables our modern lifestyle.

The timber industry, once a mainstay in Washington's economy, continues to stagnate following a sharp decline during the 1980s war of the woods. During the intervening years, forest communities like Forks, WA have experienced decreased revenue, job losses, and challenges to their community identity. Throughout the west end of the Olympic Peninsula, densely planted clear cuts are growing into forests thick with small-diameter trees that compete for nutrients and sunlight. These forests are engineered for timber production; however, legal battles and mill closures in recent years have left these forests underutilized.

Concurrently, contemporary architecture primarily utilizes steel and concrete in the construction of medium rise and high-rise buildings. While they afford structural



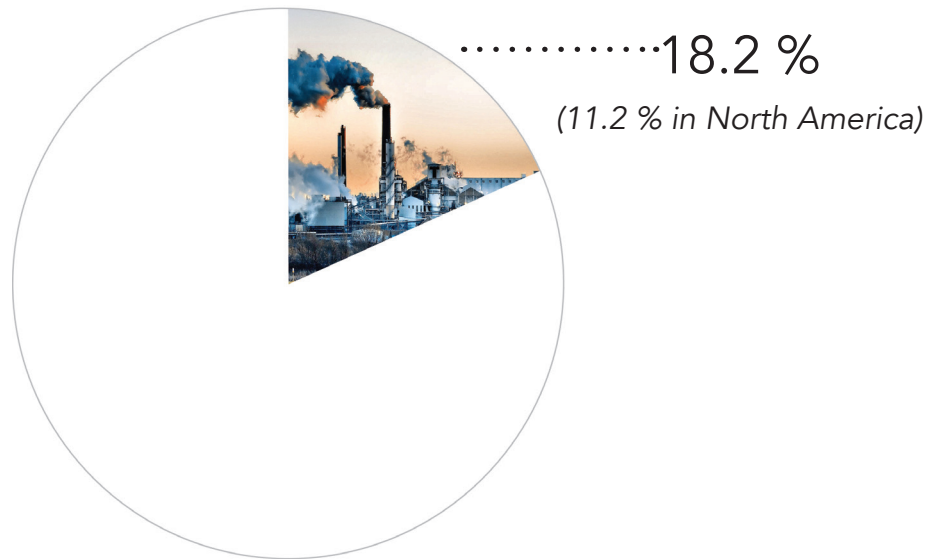
Fig 1: Scenes from Washington's Olympic Peninsula

strength and flexibility, the production of these materials is energy intensive and together they account for over 50% of industrial CO<sub>2</sub> emissions.<sup>1</sup> The building industry has a responsibility to seek alternative materials with a lower carbon footprint. The substitution of wood building materials could cut, "14 to 31% of global CO<sub>2</sub> emissions and 12 to 19% of global fossil fuel consumption"<sup>2</sup> Engineered timber products provide one alternative, and Cross Laminated Timber in particular has experienced a growth in popularity due to a number of benefits, including its ability to span in multiple directions. The state of Washington does not yet have a facility capable of producing Cross Laminated Timber. While there are currently three CLT facilities in the Pacific Northwest, none is near Washington's population centers. Moreover, products purchased from these facilities would not contribute to local economies.

1 Carpenter, Anne. 2012. CO<sub>2</sub> abatement in the cement industry. IEA Clean Coal Centre, 8.

2 Oliver, CD., Nassar, NT., Lippke, BR., & McCarter, JB. (2014). Carbon, Fossil Fuel, and Biodiversity Mitigation with Wood and Forests. *Journal of Sustainable Forestry*, 33(3), 248-275.

## Global CO<sub>2</sub> Emissions from Manufacturing & Construction



## Global Industrial Emissions

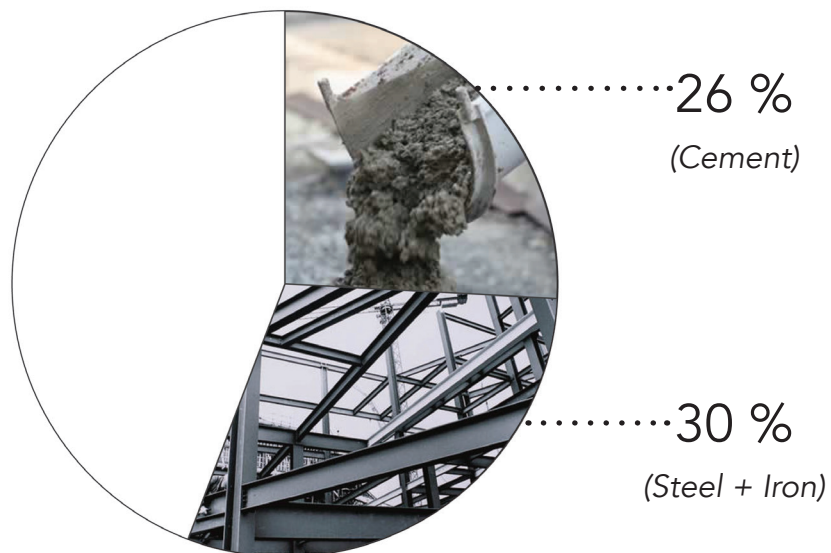


Figure 2.1: Construction and manufacturing account for 18 percent of CO<sub>2</sub> emissions.

Figure 2.2: Steel and concrete account for 30% and 26% of industrial CO<sub>2</sub> emissions respectively.

These issues create a unique opportunity to intervene in a way that would revive the economy and supply a critical product that at present does not exist in the State of Washington. This thesis proposes a new approach to the timber industry, one in which the manufacture of engineered wood products can help to bring new life to the forest communities of the Pacific Northwest. This proposal aims to strike a balance between the

demands of the construction industry, the needs of forest communities, and the health and stability of the region's ecosystems. The design of the proposed CLT production facility and Center for Wood Innovation will be located on the site of the recently defunct Interfor mill near Forks, Washington. The thesis will explore how architecture can support and express the functions of production, collaboration, and education on this site, and how such a facility could act as a bridge between resource extraction and the surrounding landscape. The facility will aim to exhibit the capabilities of CLT through its structure and its use, creating a variety of spatial experiences with one material.

To explore this proposal, this thesis will begin with a brief chronology of the people and forests of the west end of the Olympic Peninsula. This includes an overview of forest ownership in the region, and its effect on local economies. This investigation will continue with an overview of the current demand and availability of CLT in the Pacific Northwest. It will then proceed with a brief overview of the processes involved in the production of CLT. With this outline, this thesis endeavors to show that this material can help link the consumption and conservation of a resource.

---

## A Proposal for a New Path Forward

*If it were more ordinary country, less lovely and less hard, maybe the love and the outrage would not be so keen. But there is a quality about the forested mountains of the Olympic Peninsula, that very northwestern corner of the continental United States, that gets a grip on the mind and heart. (Dietrich)*

### *A Confluence of Resources: The People and Forests of Forks*

On the west side of the Olympic Peninsula, the town of Forks is situated at the confluence of the Bogachiel, Sol Duc, and Calawah Rivers. The town, which was built upon the timber industry, is isolated by the complex topography and thick forests of the region. Highway 101 winds through the peninsula, acting as the critical thread connecting Forks and surrounding communities to Olympia, Port Angeles, and the ferrys to Seattle. Along the highway, logging trucks, clearcuts, acre after acre of uniform trees, and residual old growth are indicative of the patchwork of forests and ecologies that are the product of an industry which has undeniably altered the region. This landscape exists in dramatic contrast to the nearby Hoh Rainforest, which offers a glimpse into the ancient forests that once extended throughout the countryside to the rugged coastline which rises out of the Pacific Ocean. Generations of forestry on the west end of the Olympic Peninsula, have created an inextricable link between the forests and people of this region.

Prior to non-First Nation settlement of the area, the Quileute Nation inhabited much of the West End of the Olympic Peninsula, including the relatively flat prairie that



Fig 2.1: In stark contrast to the dense surrounding forest, open land is an enticing commodity on the Olympic Peninsula. Along HWY 101, north of Forks, WA.

would later become Forks. The Quileutes annually set fire to the prairie, stimulating the growth of bracken ferns, and enticing migrating elk herds for hunting.<sup>1</sup> This practice prevented the dense forest from encroaching on open land, and so it was that early settlers found an open expanse of fertile land, seemingly ideal for farming.

Settlement of the Olympic Peninsula's West End began slowly, with fur trappers and farmers first arriving in the Forks area in the 1850s. These early explorations precipitated the treaties of 1855 and 1856, when the tribe unknowingly ceded its traditional land in exchange for the protection of their rights to hunt and fish. In 1889, a one-square mile reservation was set aside for the tribe in the small community of La Push.<sup>2</sup>

The Homestead Act of 1862 induced a wave of settlement across the nation. The act stipulated that an individual could claim 160 acres of land for a nominal fee, five

---

1 Reagan, Albert B. "Plants used by the Hoh and Quileute Indians." *Transactions of the Kansas Academy of Science* (1903-) 37 (1934): 55-70.

2 Ruby, Robert H, and John Arthur Brown. *Indians of the Pacific Northwest: A history*. University of Oklahoma Press, 1988.

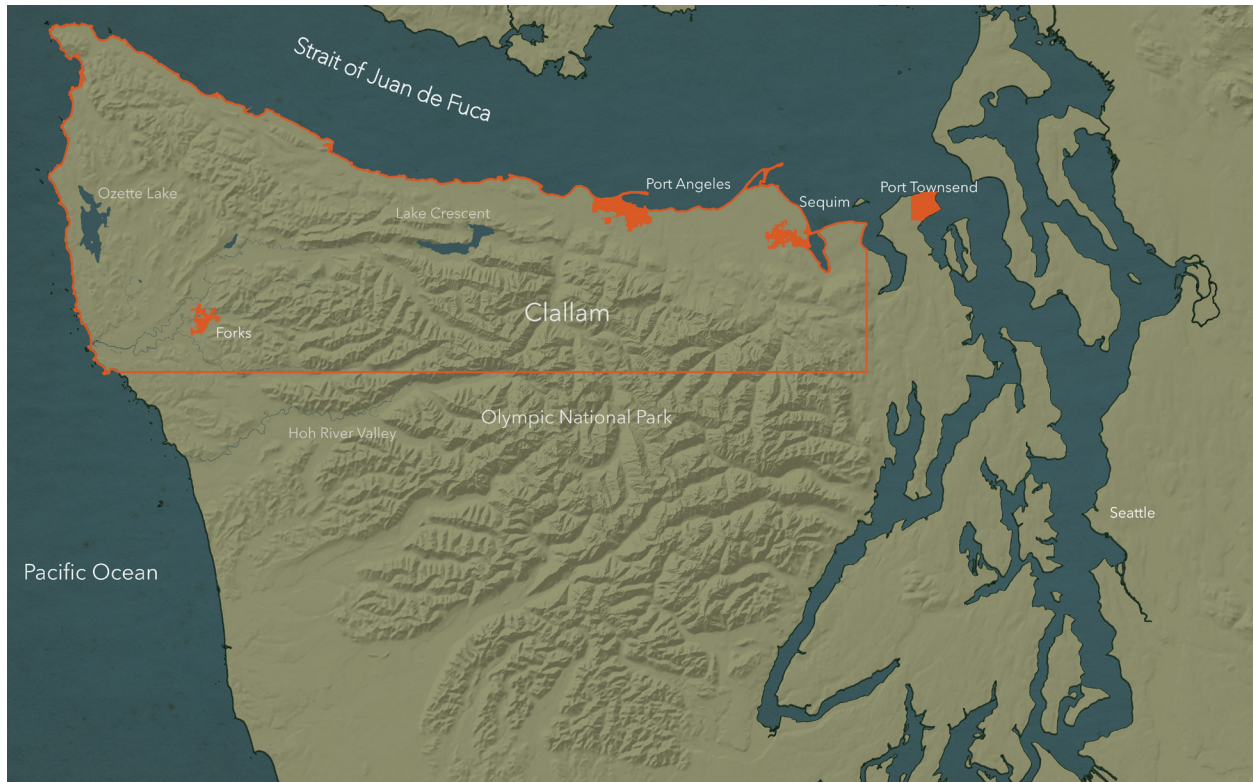


Fig 2.2: A hillshade emphasizing the mountainous core of the Olympic Peninsula.

years of continuous occupation, and a number of small improvements to the land. One of these required improvements was the introduction of agriculture to the site, a task which often proved difficult on the peninsula. Hops was popular among early settlers, and though abundant rainfall helped growth, it also made storage and transportation of the crop difficult. Port Townsend, the nearest neighbor, was 100 miles away. No road or railroad connected Forks to other peninsula settlements, so farmers and trappers had to transport their product through the mouth of the Quillayute River at La Push. The success of this dangerous endeavor was often dictated by tidal conditions and weather, and crops often rotted waiting for ideal conditions.<sup>3</sup> Though settlers prospered despite these difficulties, the climate and isolation of Forks would prove to be challenging for generations to come.

---

With the onset of WW1, planes such as the Spruce Goose were constructed using

3 "Olympic Peninsula Community Museum - Online Exhibits - Homesteaders and Pioneers." *Homesteaders and Pioneers*. Accessed May 21, 2016. <http://content.lib.washington.edu/cmpweb/exhibits/homesteading/index.html>.



Fig 2.3: The Spruce Production Division harvests a spruce tree, 9 feet in diameter, in Clallam County.

spruce trees, the strongest wood by weight in the world. In 1918, the Army created the Spruce Production Division, a 30,000 man unit charged with penetrating the dense forest with railroads and roads. In just six months, the unit constructed a railroad extending to Lake Pleasant, just to the north of Forks.<sup>4</sup> The war ended shortly after the completion of the line, however the construction of the railway helped to set the stage for the timber industry in the area. Bloedel Donovan purchased thousands of acres of forest near Forks in 1921. Though much of the land was accessible by the existing rail, the company elected to build over 100 miles of rail line in order to connect logging camps to Sekiu, Washington. Logs were then floated through the Strait of Juan de Fuca to Bellingham for milling. At the peak of their Clallam County operation, Bloedel Donovan harvested 300 million board feet per year, bringing prosperity to the West End of the Olympic Peninsula.<sup>5</sup>

4 Dietrich, William. *The final forest*. Simon and Schuster, 1992, 98.

5 1 Board Foot = 144 in<sup>3</sup> or 1' x 1' x 1"

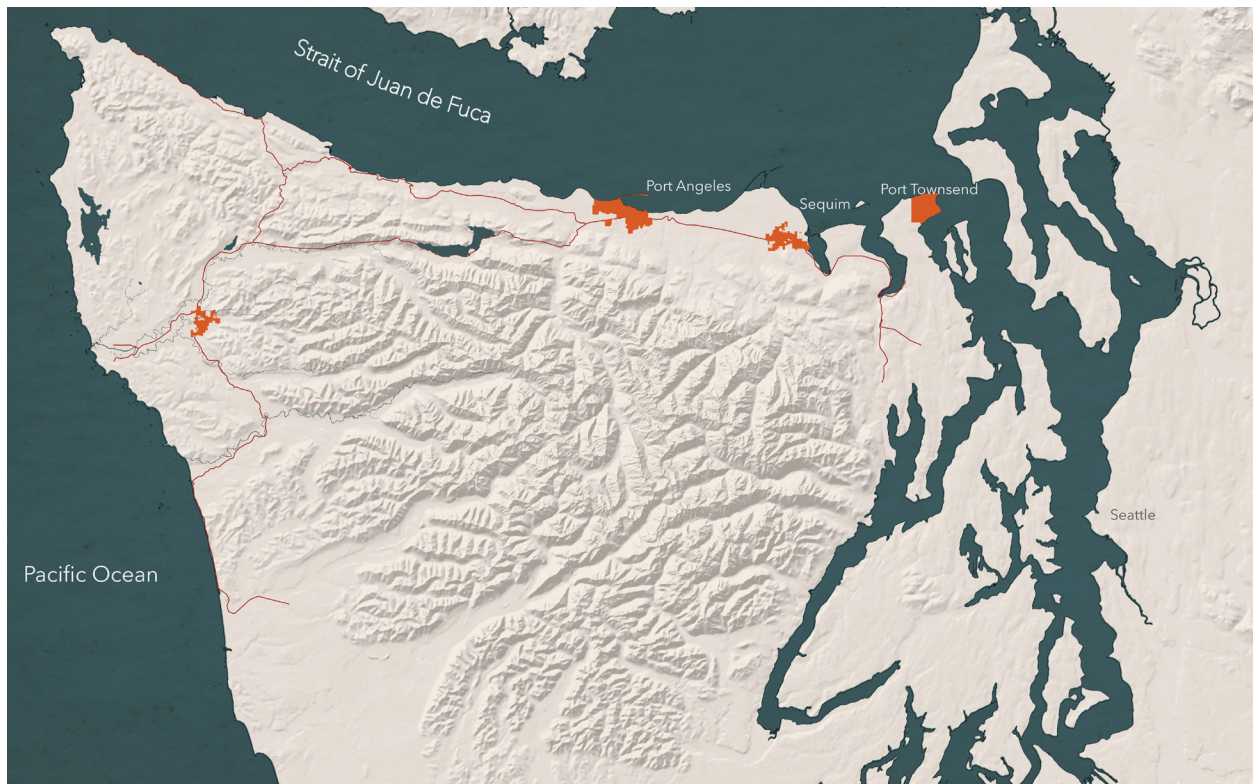


Fig 2.4: A hillshade emphasizing the mountainous core of the Olympic Peninsula.

Various attempts were made to thread a road through the topography of the region, however it was 1931 before highway 101 made its way to Forks, finally connecting the town to Port Angeles and Port Townsend. Figure 2.4, a hillshade of the Olympic Peninsula, shows Highway 101 in red. The map also helps to illustrate the topography of the peninsula's dense, mountainous core. With the interior of the peninsula inaccessible to settlers, communities formed in the relatively flat areas around the region's perimeter. Incidentally, when 101 was carved through the countryside, its route traced a path between these communities, following the flattest available land. The completion of the road provided access to large swaths of douglas fir and sitka spruce just to the south of Forks, attracting additional timber companies such as Crown Zellerbach, Rayonier, and Merrill & Ring, and turning Forks into a busy center of commerce.<sup>6</sup> From loggers and truck drivers, to sawyers and mill workers, these companies employed 100s of workers.

---

<sup>6</sup> Douglas, William Orville. *The Last Frontier in a Dark Forest: Forks, Washington*. Publisher not identified, 1964.



Fig 2.5: (Top left) Looking north through Forks in 1916.

Fig 2.6: (Bottom left) Downtown Forks during the opening of the Olympic Loop Highway (101) in 1931.

Fig 2.7: A road cuts through the dense forest just outside of Forks.

The surge of available timber also led to the opening of smaller, family-owned mills in Forks. These mills were often focused on secondary wood processing, such as cedar shingle production. The Forks Shingle Mill for example, opened in 1934 and was a major employer for 30 years, producing shingles for roofing and siding.<sup>7</sup> In addition to connecting Forks to neighboring communities, the completion of Highway 101 created greater access to the forests, extending the range of workers in Forks. Today, the highway continues to be the primary infrastructure for the movement of people and resources on the peninsula, and is a crucial part of day to day life.

Timber continued to rule the region's economy through the 1980s, and the intervening decades marked the apex of the industry in Forks. This 'boom' was precipitated by a series of disasters that created a surplus of wood. "The Great Forks Fire" of 1951, began in early August along a railway near Lake Crescent, and was

<sup>7</sup> Russell, Jervis. *Jimmy Come Lately, History of Clallam County: A Symposium*. Jervis Russell. Clallam County Historical Society, 1971.



*Fig 2.8: Mrs. and Mr. Maxwells hose down the remains of their hotel. The Maxwells and other residents of Forks were able to save many homes by wetting them down before the approaching fire. The Great Fire of 1951 made huge amounts of timber available, leading to a boom in the city's economy.*

contained after burning 1,600 acres of private and public forest.<sup>8</sup> A hotspot smoldered for weeks, and on September 20, winds rekindled a flame. Catalyzed by an exceptionally dry summer and with the winds at its back, the fire raced towards Forks covering 18 miles in a single day. Though authorities ordered residents to flee the town, many members of the community opted to stay and assist in defending the town against the looming conflagration. As embers rained down upon houses, residents and firefighters hosed down buildings and used whatever they could find to stamp out fires. "The fact that the town is still there — most of it at least — is a tribute to the dogged persistence and guts of a couple of hundred sturdy men," remarked Oscar Herd, the town's fire chief. In all

<sup>8</sup> Lake Crescent is 35 miles from fork via Highway 101.



Fig 2.9: A timber export terminal in Longview, WA helps to illustrate the scale and impact of international timber exports.

the fire consumed 33,000 acres and 32 buildings in Forks.<sup>9</sup> (Photo) A decade later The Columbus Day Storm of 1962, devastated the Pacific Northwest, but spared Forks. In Naselle, just south of Forks, winds of 150 mph were recorded. The tempest resulted in the lose of 52 lives, the damage of 53,000 homes, and the felling of 15 billion board feet of timber. Timber markets surged, but local markets could not absorb the huge influx of timber, and international markets were created to stimulate demand. With such an abundance of lumber, the timber industry thrived, and other businesses sprung up in the bustling town in order to serve the growing population. During the 1970s the population of Forks doubled, and it became known as the “Timber Capital of the World.”<sup>10</sup> The community’s dramatic expansion and thriving economy would prove to be short lived, as the following decades would provide the town with a new set of challenges.

9 Amundson, Mavis. *The Great Forks Fire*. Western Gull Pub., 2003.

10 Dietrich, William. *The final forest*. Simon and Schuster, 1992, 103.



2.10: Increased mechanization enabled the proliferation of clearcutting. This tactic used to harvest large swathes of forest, resulted in the destruction of habitat, drawing attention from environmental communities.

The national recession at the start of the 1980s marked the beginning of the decline in Forks' timber industry. Some small companies shuttered their doors while others were purchased by larger corporations, but the result was the same: many workers in the industry lost their jobs, with unemployment in the town leapt to 19% by 1982. Additionally, the supply of salvaged wood that spurred the boom of the 1970s was dwindling, leading to the closure of mills that focused on secondary products like shingles. While the boom of the previous decade had doubled the town's population, between 1980 and 1990, Forks' population dropped from 3,060 to 2862.<sup>11</sup>

While the national economy, foreign markets, and increased mechanization of timber harvesting and milling threatened the timber industry throughout the 1980s, the following decade revealed the industry's largest threat yet: the spotted owl. The rapid harvest of Pacific Northwest Forests gained the attention of environmental groups who rallied around the spotted owl as an indicator species for the health of the larger ecosystem.

<sup>11</sup> Buttolph, Lita P et al. "Northwest Economic Adjustment Initiative Assessment: Forest Community Research. Forks, Clallam County, Washington." (2006).



Fig 2.11 - 2.13: The spotted owl sparked a heated debate between conservationists and loggers. The long battle gained national attention, and had profound and lasting implications for the timber industry.

The Endangered Species act, signed into law in 1973, became a critical foothold for environmentalists. Pitting ecology and habitat against the timber industry, the act allowed for the protection of entire ecosystems for the viability of a single species. "The timber industry argued that if policy makers could not be certain a particular tract of trees was necessary for spotted owl survival, society should allow logging to proceed. The burden of proof, they contended, should be on the owl and its biologists. Environmentalists maintained the opposite, that if there was not absolute certainty then logging should stop until there was."<sup>12</sup> Each side poured money and research into supporting their claims, and ultimately in 1991, the spotted owl was declared an endangered species. In addition to national and state parks reserves, 11.6 million acres were set aside as critical habitat for the spotted owl, including reserves up to 10,000 acres near Forks.<sup>13</sup> By the end of the 1990s timber harvest on federal land in the Pacific Northwest dropped 90 percent from their peak harvest. "The spotted owl crystallized the power of the species-protection law. No threatened animal has done more to change how we use land."<sup>14</sup> With large swathes of forest off limits, the timber industry slipped further into decline.

12 Dietrich, William. *The Final Forest: Big Trees, Forks, and the Pacific Northwest*. Seattle: University of Washington Press, 2010, 80.

13 *The Final Forest*

14 "The Spotted Owl's New Nemesis | Science | Smithsonian." 23 April. 2016 <<http://www.smithsonianmag.com/science-nature/the-spotted-owls-new-nemesis-131610387/>>



Fig 2.14: Forest ownership on the Olympic Peninsula. The inner core (dark green) is occupied by Olympic National Park. The next ring, shown in olive green, represents land owned by the state of Washington (DNR). Finally, the lightest green highlights privately held timberlands.

As shown in figure 3.4, DNR owns and controls a considerable amount of forestland in Clallam County. DNR was formed to manage state trust lands in an effort to generate revenue for schools and preserve habitat. The Olympic Natural Resource Center (ONRC), located just to the south of Forks, a collaboration between the DNR and the University of Washington, exists to facilitate research and provide information to support the integration of environmental and economic interests. DNR in conjunction with the ONRC, is leading efforts to research a balanced approach to forestry in the region. These efforts include the establishment and study of innovative forest plots, and the promotion of new forest product technologies, such as the production of fuel via pyrolysis and the production of CLT.

In Washington, the Department of Natural Resources aimed to strike a balance between regenerating healthy forest ecologies while providing a sustained timber harvest for local economies. In 2004 DNR conducted its 10 year harvest calculations



*Fig 2.15: A test plot for thinning in an experimental forest treatment. DNR land near Forks, WA.*

and decided that 575 million board feet could be sustainably harvested each year from the Olympic Experimental State Forest. As part of its mission, DNR worked with environmental groups to develop a long term plan for preserving mature forest habitat in the Olympic Peninsula, and continued logging state lands during that time. However, the spotted owl was not the only bird with ruffled feathers. Environmental groups set their sites on the marbled murrelet as another species indicative of forest health. In 2012 the Seattle Audubon Society and Olympic Forest Coalition sued DNR for the harvest of 12,000 acres of forest on the peninsula. Part of the settlement restricted the state to the harvest of forests under 50 years old. Additionally, 50% of this harvest had to be the product of forest thinning. A concurrent drop in lumber prices, particularly hemlock, which makes up a large part of DNR land, further influenced the decrease in regional timber production.<sup>15</sup>

<sup>15</sup> Ollikainen, Rob. "Timber Left Standing on Department of Natural Resources Trust Lands While Peninsula Mills Shut down." *Peninsula Daily News*. June 12, 2015. Accessed May 17, 2016. <http://www.peninsuladailynews.com/article/20150612/NEWS/306129967>.



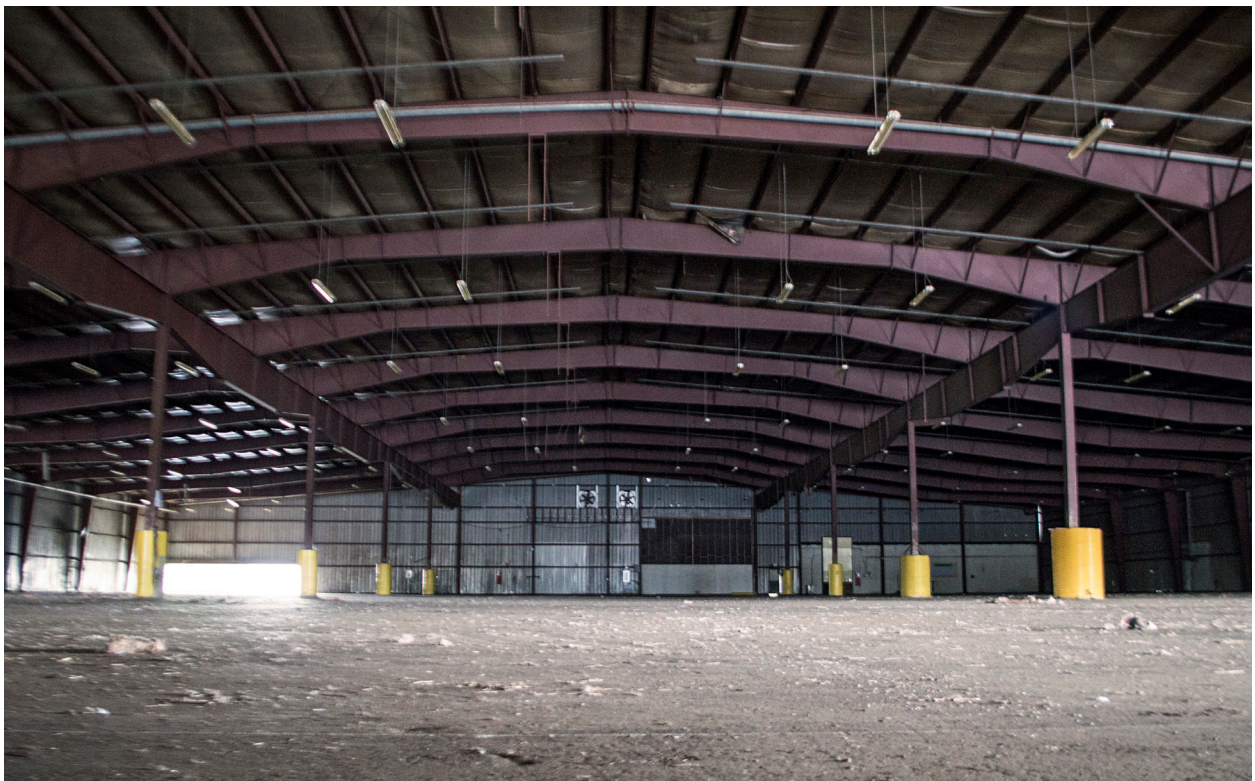
Fig 2.16: A sign on privately held timberland along highway 101, just north of Forks.

While DNR works to complete a comprehensive strategy for marbled murrelet protection and a new 10-year sustainable harvest calculation, much of the 92,525 acres of DNR land in Clallam County remains protected. Of the 575 million board feet that DNR forecasted for sale in Clallam County, 218 million remain in arrearage. The lack of availability of timber in the region has contributed to the closure of the West End's last three production mills. In 2014 Interfor closed the doors of its planing mill in Forks, and its sawmill in Beaver. These closures were followed closely in 2015 by Allen Logging Co. in nearby Jefferson County, which operated for the last 60 years, employing residents of Forks.<sup>16</sup> The closure of these three mills signaled the end of an era. Tax revenue generated by the mills plummeted reducing funds available for local schools and 168 industry workers lost their jobs.

16 "Recent mill closures and Allen Logging Co. - Peninsula Daily News." 2015. 17 may. 2016 <<http://www.peninsuladailynews.com/article/20150612/NEWS/306129967>>



*Fig 2.17: Remnants of the debarking station at the Beaver Division of the Interfor Mill.*



*Fig 2.18: An vacated planing warehouse at the Forks Division of the Interfor Mill.*

The forests visible today from Highway 101 are not the ancient forests that once loomed over the first nations people and early settlers of this region. Though small pockets of old growth persevere, the majority of forests along the transportation corridor are managed forests that have been planted for commercial harvest. At 70 MPH the various parcels may look similar, but their composition and health vary greatly. These are not wild forests, but engineered landscapes that represent layers of calculated harvest and replanting over time. The complex forest ecologies labeled as old growth cannot be simply replanted, however foresters are continuously researching forest treatments that strike a balance between profitable production and the promotion of healthy, diverse ecosystems. Likewise, the timber industry on the West End cannot be revitalized using the same practices that originally brought prosperity to the community.

“The economy, which supplies jobs and income, is fundamental to resident’s health (e.g., ability to meet basic needs of food, clothing, and shelter) as well as higher order needs including education, healthcare, and recreation. At the same time, the economy should efficiently utilize raw materials drawn from the environment, so as to ensure sufficient resources for current and future generations... The environment is the critical infrastructure that provides natural resources, the capacity for waste assimilation and links between people and the natural world.”<sup>17</sup>

The underlying problem with the big timber business model, is that the investment in infrastructure necessitates an unsustainable harvest. Large corporations approach communities with the ostensible benefits of jobs and taxable revenue, however, with so much upfront investment the company’s priority is its investors rather than the health of the forest or the welfare of the community.<sup>18</sup>

---

17 K.E Stein, et al., *Community and Quality of Life*(Washington D.C.: National Academies Press, 2002), 32.

18 Berry, Wendell. *Another turn of the crank: Essays*. Counterpoint Press, 2011.



*Fig 2.19: Commercial forests flank highway 101, between Forks and Crescent Lake.*

## A New Material in the Pacific Northwest

The current brand of forestry on the peninsula is centered around the production of dimensional lumber and the international export of raw timber. This thesis proposes that the path forward requires a more balanced approach. One that shifts from a single model dependent on quantity, to a diversified industry comprised of innovative, value-added products. Cross Laminated Timber is one such product that has recently grown in popularity in the Pacific Northwest. There are three regional producers of the engineered panels, however, the state of Washington does not yet have a production facility.



Fig 2.20: A shift in industry.

## The Panel

Cross Laminated Timber (CLT) is an engineered timber product that is comprised of successive arrays of dimensional lumber. Each layer of the panel is made up of 2x6 studs, which are first finger jointed and planed. Each layer is rotated 90 degrees to be perpendicular to the previous layer. The layers are glued together and then pressed to form a composite panel. This composition gives the panel the ability to span in multiple axes. CLT consists of an odd number of panels, coming in 3, 5, 7, and 9 layer configurations. Thicker panels are able to support larger loads. In all configurations, the members of the top and bottom layers run parallel to the strong axis of the panel. Panel width is limited to 10 feet (governed by shipping constraints), and the panels are typically made up to 40 feet long. While CLT presses are made at a fixed width, they are modular, so in theory, panel length could extend well beyond 40 feet.

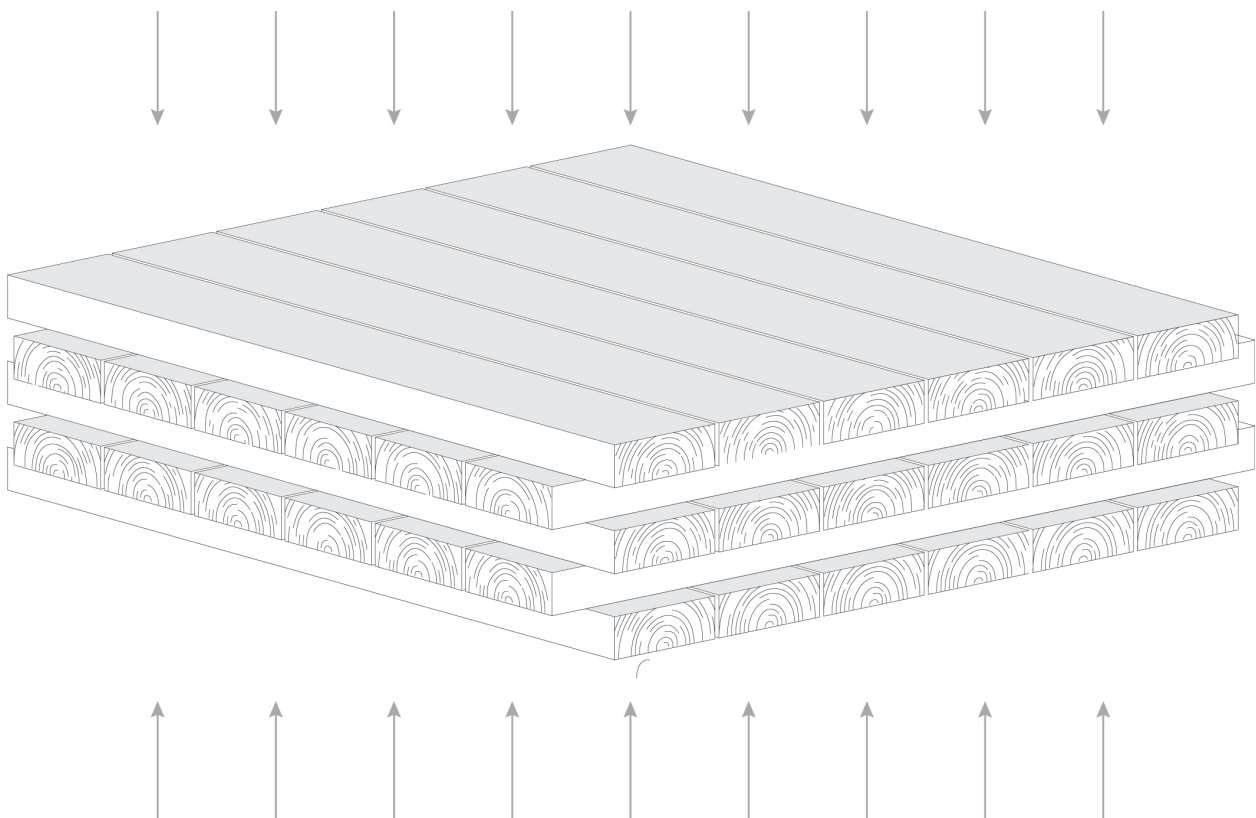
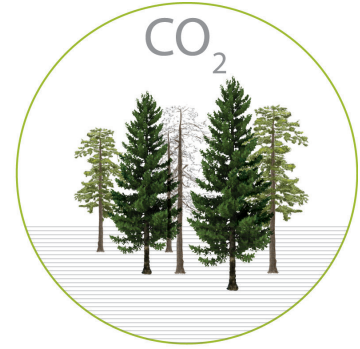
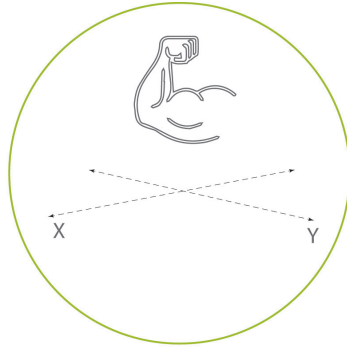


Fig 2.21: CLT layup diagram



There are a number of benefits associated with using CLT as a building material. These panels utilize dimensional lumber from regional forests providing jobs, and generating revenue for the local economy. By adding to the diversity of timber products, the production of CLT opens a new market for dimensional lumber.

As mentioned before, CLT has the ability to span in multiple directions. Glue laminated beams are made are comprised of members that run in parallel, limiting their span to one dimension. This allows glulam to be used in the place of steel. Owing to its composition of perpendicular members, CLT is a panel system, which can span in two dimensions. Cross lamination gives the panels high in-plane and out-of-plane bending strength, shear strength, and stiffness.<sup>1</sup> These properties give CLT the ability to replace concrete in many applications including floor plates and sheer walls. These substitutions in a buildings structural systems could profoundly impact the life cycle of the buildings.

CLT and other engineered wood products have the potential to reduce the carbon footprint of buildings. Steel and concrete, the most widely used structural materials in buildings, account for 30% and 26% of industrial CO<sub>2</sub> emissions.<sup>2</sup> As trees grow they sequester atmospheric carbon. When trees are sustainably harvested, that carbon is locked away in the resulting timber product. Often the amount of carbon stored by mass timber members exceeds the carbon produced during their manufacture, making them net positive with regards to their carbon footprint. Because CLT can be used in the place of concrete in so many applications, CLT offers great potential for lowering the overall

---

1 Council, Binational Softwood Lumber. *CLT Handbook: Cross-laminated Timber*, Vol. 1. Erol Karacabeyli & Brad Douglas. FPInnovations, 2013, 6.

2 Carpenter, Anne. 2012. *CO2 abatement in the cement industry*. IEA Clean Coal Centre, 8.



impact of buildings.<sup>3</sup>

The panels can be prefabricated with a high degree of precision, leading to a reduction in waste and a decrease in construction time.<sup>4</sup> In the case of Albina Yard, a four-story office project in Portland, OR, the contractor reported that the first floor of CLT, covered an area of 4,000 square feet, and was installed in less than four hours. The successive floors were put in place in under 2 hours with a small crew of seven workers. The contractor estimated that using traditional construction methods would have taken a crew twice as large two days to complete.<sup>5</sup>

As CLT is commonly used as both a structural and finish material, CLT has unique requirements for fire resistance. Test have demonstrated that CLT retains its structural integrity when exposed to sustained fire tests. This is in part due to the ability of charring to protect the panel from heat. Similar to the bark of a tree allowing the tree to survive a forest fire, the initial charring of a panel provides some protection for successive layers. Fire<sup>6</sup>

The Pacific Northwest is a seismically active area, and with any building in the region, resiliency to earthquakes is a crucial consideration. Ongoing research has concluded that CLT preforms well in seismic events and could be used as the primary structural system in buildings between 8-20 stories tall.

<sup>3</sup> Oliver, CD., Nassar, NT., Lippke, BR., & McCarter, JB. (2014). Carbon, Fossil Fuel, and Biodiversity Mitigation with Wood and Forests. *Journal of Sustainable Forestry*, 33(3), 248-275

<sup>4</sup> Gagnon, S, and E Karacabeyli. "Status of cross-laminated timber construction in North-America." *Structures and Architecture: New concepts, applications and challenges* (2013): 66.

<sup>5</sup> "Mass timber rising | Oregon Forest Resources Institute." Accessed December 15, 2016. <http://oregonforests.org/blog/mass-timber-rising>.

<sup>6</sup> Pei, Shiling, Douglas Rammer, Marjan Popovski, Tom Williamson, Philip Line, and John W. van de Lindt. "An Overview of CLT Research and Implementation in North America." (2016).

## *Growing Acceptance & Excitement*

Development of modern Cross Laminated Timber began in Austria during the 1990s. Since then, the panels have gained acceptance and popularity in other European countries, and have been successfully incorporated in hundreds of building projects across the continent.<sup>1</sup> The material is rapidly gaining popularity in the Pacific Northwest, where forests are abundant, and regional architecture has a tradition of incorporating heavy timber. Many CLT projects are on the books, and several notable projects have already demonstrated the viability of CLT in the region including: Albina Yard in Portland, Oregon, by Lever Architecture and Reworks Inc.; The Wood Innovation and Design Centre in Prince George, British Columbia, by Michael Green Architects; and the Bellevue First Congregational Church in Bellevue, Washington, by Atelierjones.



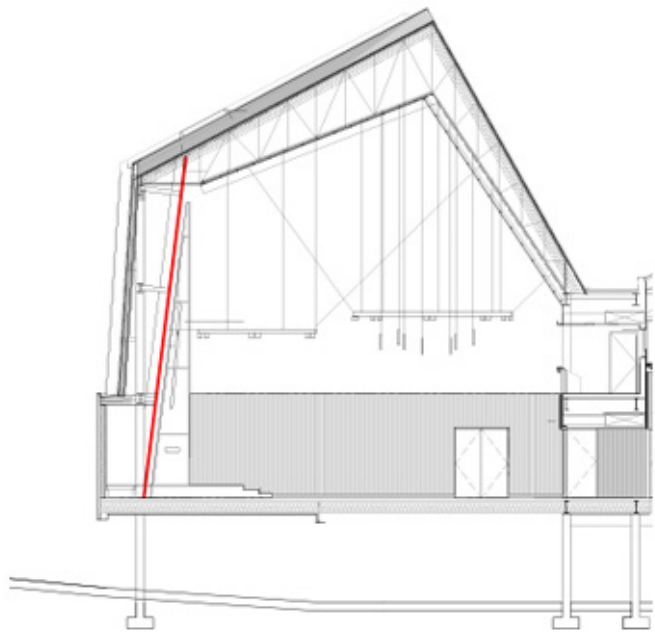
*Fig 2.23: Albina Yard in Portland, OR. Building Design by Lever Architecture and Reworks Inc.*

---

<sup>1</sup> Council, Binational Softwood Lumber. *CLT Handbook: Cross-laminated Timber*. Erol Karacabeyli & Brad Douglas. FPInnovations, 2013.



Fig 2.24: The Wood Innovation and Design Centre in Prince George, British Columbia, by Michael Green Architects



— Cross-laminated timber wall

Fig 2.25: Bellevue First Congregational Church in Bellevue, Washington, by Atelierjones.



Fig 2.26: An aerial view of the DR Johnson Lumber Co. in Riddle, OR.

### A CLT Facility

DR Johnson Lumber Co., a CLT manufacturer located in Riddle, OR, began producing dimensional lumber in the 1951 and expanded their operations to include glue-laminated beams in 1967. Experience and knowledge of adhesives gave the company a head start when they became the first certified US manufacturer of CLT in 2015.<sup>1</sup>

Though the company continues to make dimensional lumber, they prefer to source the wood for the beams and panels from another company. Lumber arrives at the glue lamination warehouse (highlighted in blue), and is finger jointed and planned before its incorporation into glue-laminated beams or CLT panels. The lamination warehouse encloses large clamps where arrays of boards are manually glued and pressed. A large planer and finishing station are located at the edge of the warehouse. When the company decided to expand into CLT production, an additional warehouse was adjoined to the

<sup>1</sup> "D.R. Johnson Wood Innovations & CLT - Oregon CLT." Accessed December 15, 2016. <http://oregonclt.com/about/>.



Fig 2.27: An employee adds a 'rusticated finish' to a glulam beam (left). The DR Johnson CLT press (right). DR Johnson's CNC router. (Below)

original. The new warehouse, includes radiant floors to help the adhesives to cure, and houses the CLT layup station, press, and router. An area next to the router provides space for the manual finishing of panels. The press is comprised of modular bays that allow for the production of panels up to 10 feet wide. Additional bays were added to allow for panels to be made up to 40 feet in length. The CNC router allows for windows, doors, utility openings, and other detailing to be routed with a high degree of precision. A vehicle-mounted-crane helps to move the heavy panels to a storage area, where they await shipping.

## Current Regional Manufacturers of CLT

Despite a storied history as one of the nation's largest timber producing states, Washington does not yet have a CLT production mill. Figure 2.x shows the three current manufacturing facilities in the Pacific Northwest: StructureLam in Penticton, British Columbia, SmartLam in Columbia Falls, Montana, and DR Johnson Lumber in Riddle, Oregon. As codes change and demand for CLT increases, it is important that the State of Washington develops its own CLT industry to utilize local forests and contribute to the local economy. Washington has an opportunity to continue as a leader in the timber industry, and the forest community of Forks, Washington is well suited to be the seed for the production of this innovative forest product.



Fig 2.29: A regional map of the Pacific Northwest which highlights current manufacturers of CLT panels.



Fig 2.30: A Satellite Image of the Olympic Peninsula



Fig 2.31: Clallam County and the West End of the Olympic Peninsula. Forks is highlighted in blue.

---

## Site Strategies & Programming

### *Why Forks?*

Forks the self described 'Timber Capital of the World' has a history and identity built on the timber industry. The community, still reeling from the decline of the industry, has an abundance of the two resources needed to drive the industry: forests and people. Local officials, the Washington Department of Natural Resources, and the Olympic Natural Resource Center, are working together to revitalize the timber industry in Forks, WA. These resources, the active presence of DNR and the ONRC in the community, and the growing demand for CLT in Washington's cities, make Forks an ideal location for Washington's first CLT production mill. This thesis asserts that a production facility alone is not a panacea for the community's timber troubles. The relationship between forests as resource and forest as ecology is complex. In order to promote a cohesive vision for a path forward, these separate paradigms need to come together physically in one place. This thesis proposes that experimental forest plots be linked to the production facility to give visitors a more complete picture. In an effort to further bridge this divide, and to bring together industry leaders, policy makers, scientists, and the public together in one place, this thesis proposes the establishment of the West End Center for Wood Innovation to promote education, research, innovation, and production.



Fig 3.1: A logging truck trundles along highway 101 through downtown Forks.

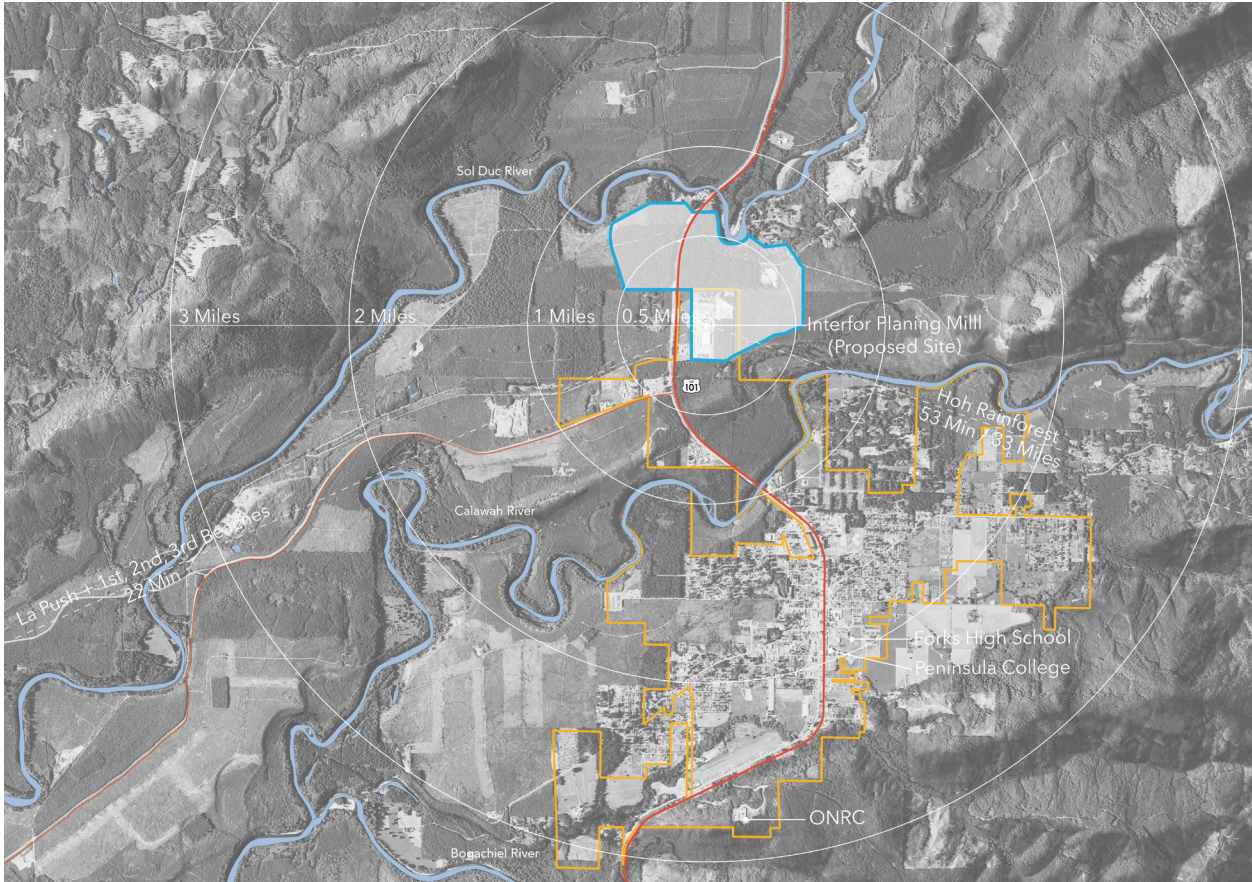


Fig 3.2: A satellite image shows the site (outlined in blue) and its proximity to 101 (shown in red) and Forks (outlined in orange).

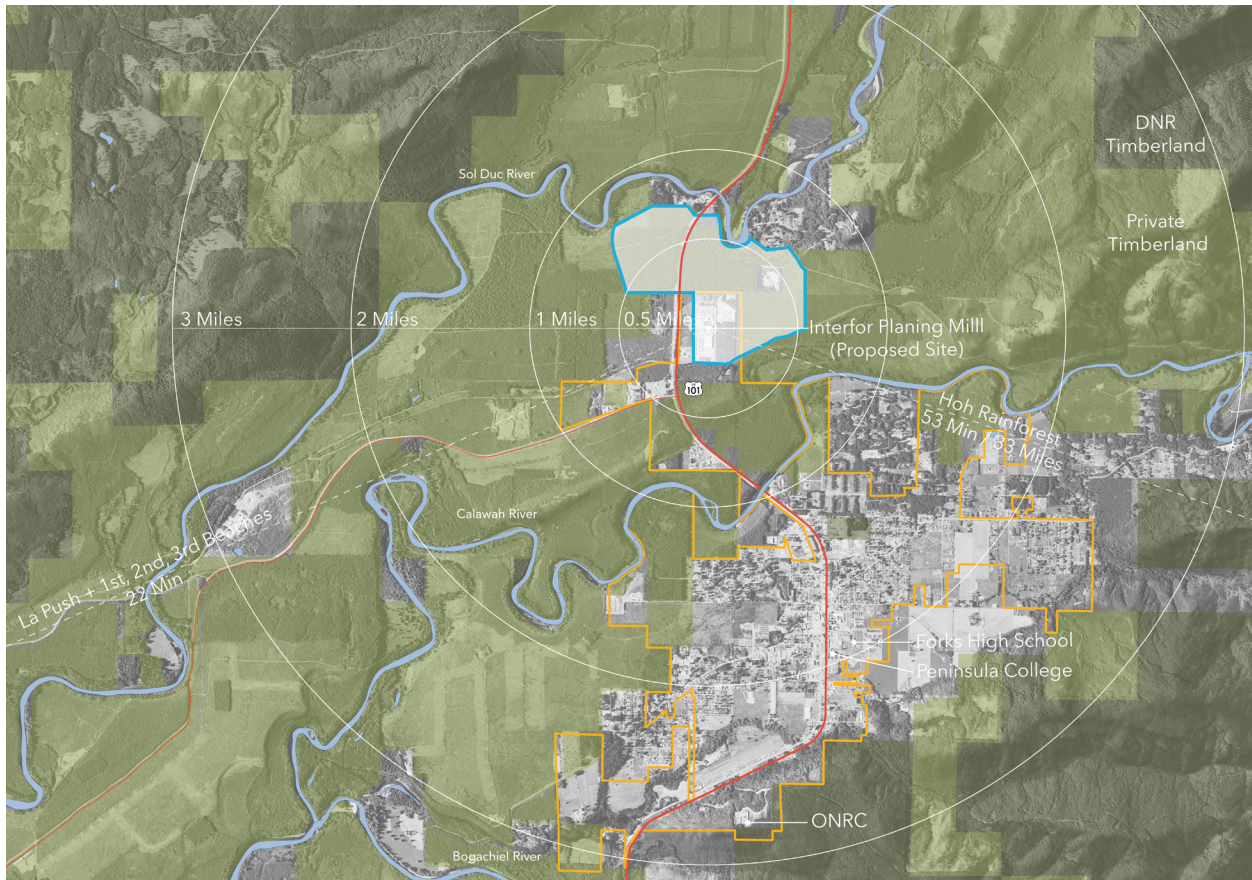


Fig 3.3: A satellite image showing the forest ownership around the selected site and Forks. Note that the land adjacent to the site is all privately owned. The Olympic Natural Resource Center, which is on DNR land, and the selected site, bookend the town of Forks.

### Site Selection Criteria

The selection of the site for the West End Center for Wood Innovation, is based upon the following criteria: proximity to highway 101 and to Forks, WA, the accessibility of DNR and private timberlands, and the utilization of existing timber infrastructure. Because highway 101 is the main infrastructure for transporting people and timber, it is crucial that the site be located along the road. The highway not only serves as the connective thread for local residents, but also for the many tourists who visit the peninsula for recreation and sightseeing. Locating the project along 101 will maximize the visibility to local residents and visitors alike. Forks is home to a large, experienced workforce. Locating the site near the community, makes it more accessible to the 168 workers, who are eager to put their skills, new and old, to work. The next generation

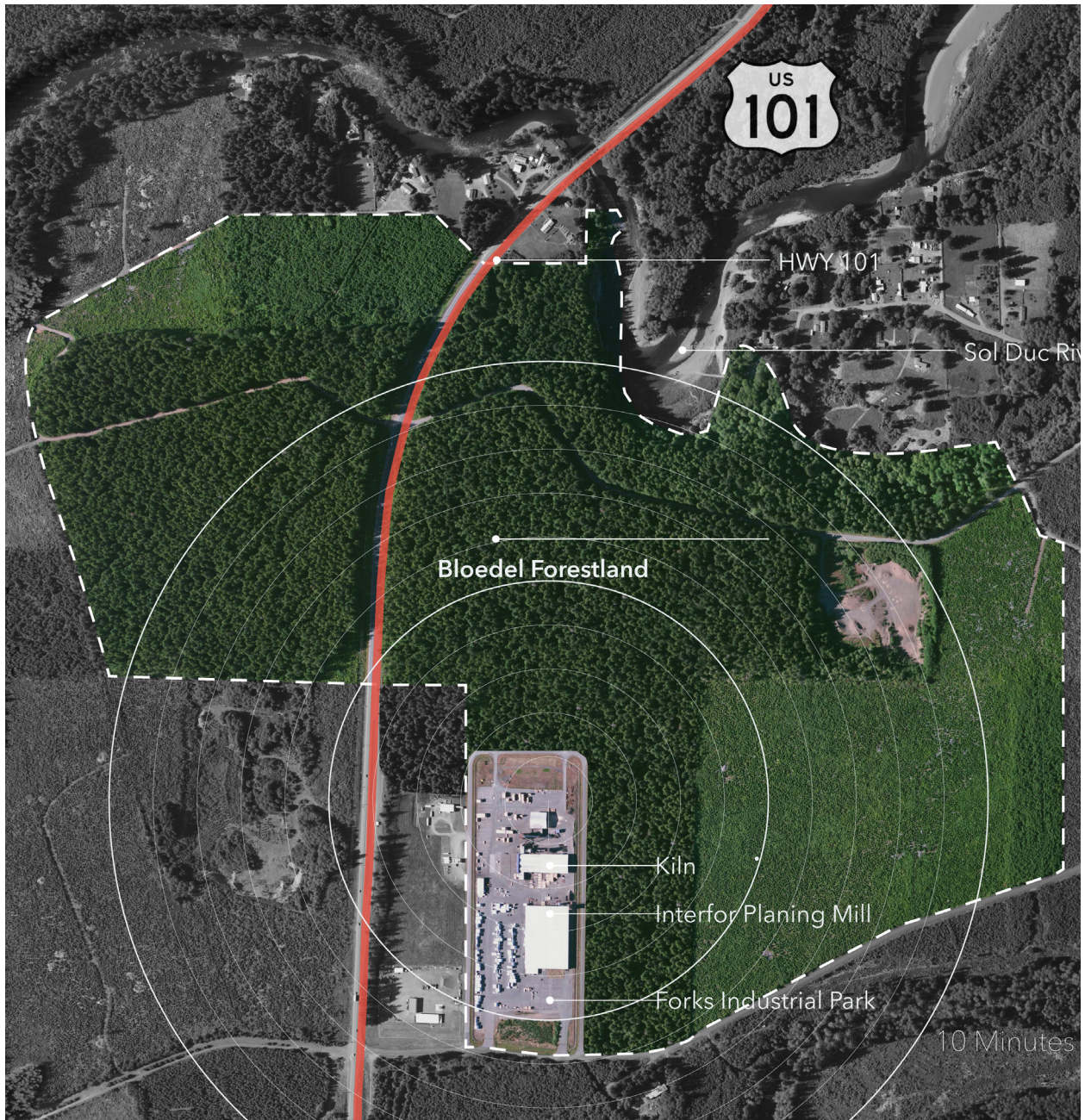


Fig 3.5: A satellite image of the site (outlined with dashed line), highlighting the proximity to highway 101 and the relationship to timberland held by Bloedel Donovan.



*Fig 3.5: The satellite images show the north end of the site to be completely forested. Infact, much of the land has been clearcut. This makes it ideal for exposing visitors to various stages of forest growth.*

of the workforce is an additional consideration. Forks is home to a satellite campus for Peninsula College, which offers degrees in material research, business, green building, forestry, applied computing, and fabrication. Locating the site adjacent to timberland provides the opportunity to link resources to production, and expose visitors to current forestry techniques. As Forks and other communities in the West End look to the future, it is important to remember and learn from the industry of the past. With this in mind, the project will be built physically and metaphorically on the existing stud mill industry in the area. With vestiges of infrastructure and ample space, these sites are ideal locations to serve as a foundation for the new mill.

Given these guidelines, the site of the recently defunct Interfor planing mill in Forks is an ideal location for the West End Center for Wood Innovation. The site sits along highway 101 just two miles from the heart of Forks, making it accessible for residents and students. Timberland owned by Bloedel Donovan sits directly adjacent to the Forks Industrial Park, and is incorporated into the site. The site selection also allows for the reuse of this site and any remaining infrastructure, preventing further deforestation, and providing an opportunity for remediating a portion of the land.



*Fig 3.6: A photo of the existing warehouse from the southeast corner of the Forks Industrial Park.*



*Fig 3.7: This warehouse once housed Interfor's planing mill. The space has remained vacant since interfor closed its west end operations in 2014.*

## *Site Plan & Strategy*

The site plan for the West End Center for Wood Innovation (shown in figure 3.8), seeks to integrate modern forestry practices, the production of cross laminated timber (CLT), and an educational center in one place. The Interfor Timber Mill occupies the space bordered by the industrial park loop, but the site's boundary expands north to include private forestland owned by the Bloedel Donovan timber company. The initial proposal focused on converting the mill to a CLT production facility, however, the incorporation of the forestland into the site presents an opportunity for visitors to see the forest as nature and as resource in one place. This dichotomy is reflected in the site plan as resources arrive to the site from the south, and visitors arrive from the north through the experimental forest. The southern zone of the site remains industrial and houses the CLT production facility in the existing Interfor warehouse, a biomass cogeneration plant, and the Center for Wood Innovation. HWY 101 which runs to the West of the site is the primary infrastructure for moving resources about the peninsula. This flow of resources is represented by the red outline which continues into the south end of the site where wood arrives and is processed into CLT. Meanwhile the northern zone exhibits a balanced approach to forestry, which yields timber for production while supporting local ecologies. This forest is open to the public and provides an experiential way for visitors to learn about sustainable forestry through exploration. Nature and resource meet at the Center for Wood Innovation where visitors can experience the various structural and spatial capabilities of CLT, and learn about forestry and CLT production.

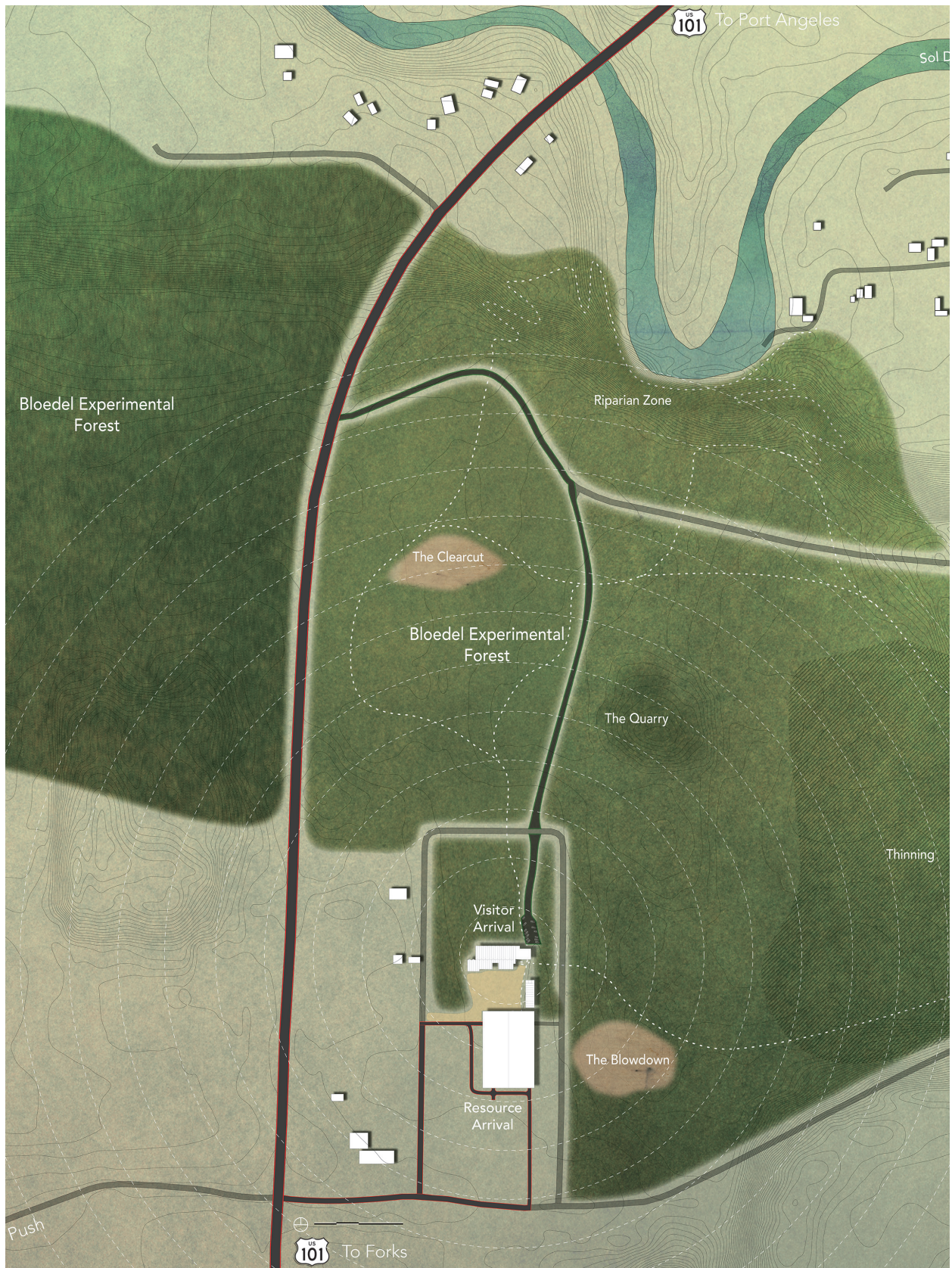


Fig 3.8: Site plan of the proposed West End Center for Wood Innovation including the production facility, Bloedel Experimental Forest, and Innovation Center.

## *The Experimental Forest*

A network of trails begins at the Center for Wood Innovation and exposes visitors to experimental plots, various tree species, under story plants, thinning operations, blowdowns, dirty clearcuts, and an example of healthy forests in riparian zones. Visitors will have an opportunity to take part in the growing cycle as they help to replant the land, which is already occupied by commercial forests of varying ages. This gradient of forest composition teaches visitors to differentiate between forest treatments and see first hand how different variables influence the yield and ecology of the forest. Some plots will reflect the native forest composition, while other test plots will represent the monocultures seen in industrial forestry. Thinning operations, blowdowns, and dirty clearcuts, expose visitors to the various low-impact methods of harvest. A clearcut will remove a swathe of forest to illustrate the amount of timber needed to construct a typical mixed use building with CLT.



*Fig 3.10: A volunteer leads a tour through a dirty clearcut, while visitors help to replant in the same area.*



Fig 3.11: Site plan showing the various elements of the Bloedel Experimental Forest.

## *Production Facility Layout*

Dimensional lumber arrives at the production facility and is stored in the southeast corner of the warehouse. From here the studs are moved to the finger jointing and planing station. Individual boards are visually inspected before they are finger jointed and glued. Once the two joined pieces are glued they are minimally planed to ensure an even composition in the layup. The long, joined boards are stored in the southwest corner of the warehouse. From here boards are transported to the CLT layup station where they are arrayed, glued, and layered. Once the layup is complete, the assembly is rolled into the CLT press. The press first aligns the perimeter of the panel, pressing in from all sides. The press then applies even pressure from above, compressing the boards into a composite panel. The panel is moved from the press to the CLT finishing area where a combination of computer aided routing and manual finishing takes the panel to completion. A gurney crane lifts the completed panel and transports it to the panel storage area at the north end of the warehouse. A radiant slab heats the storage area, helping the glue to finish setting and the panels to remain dry.



*Fig 3.12: A view showing the panel storage and shipping area.*

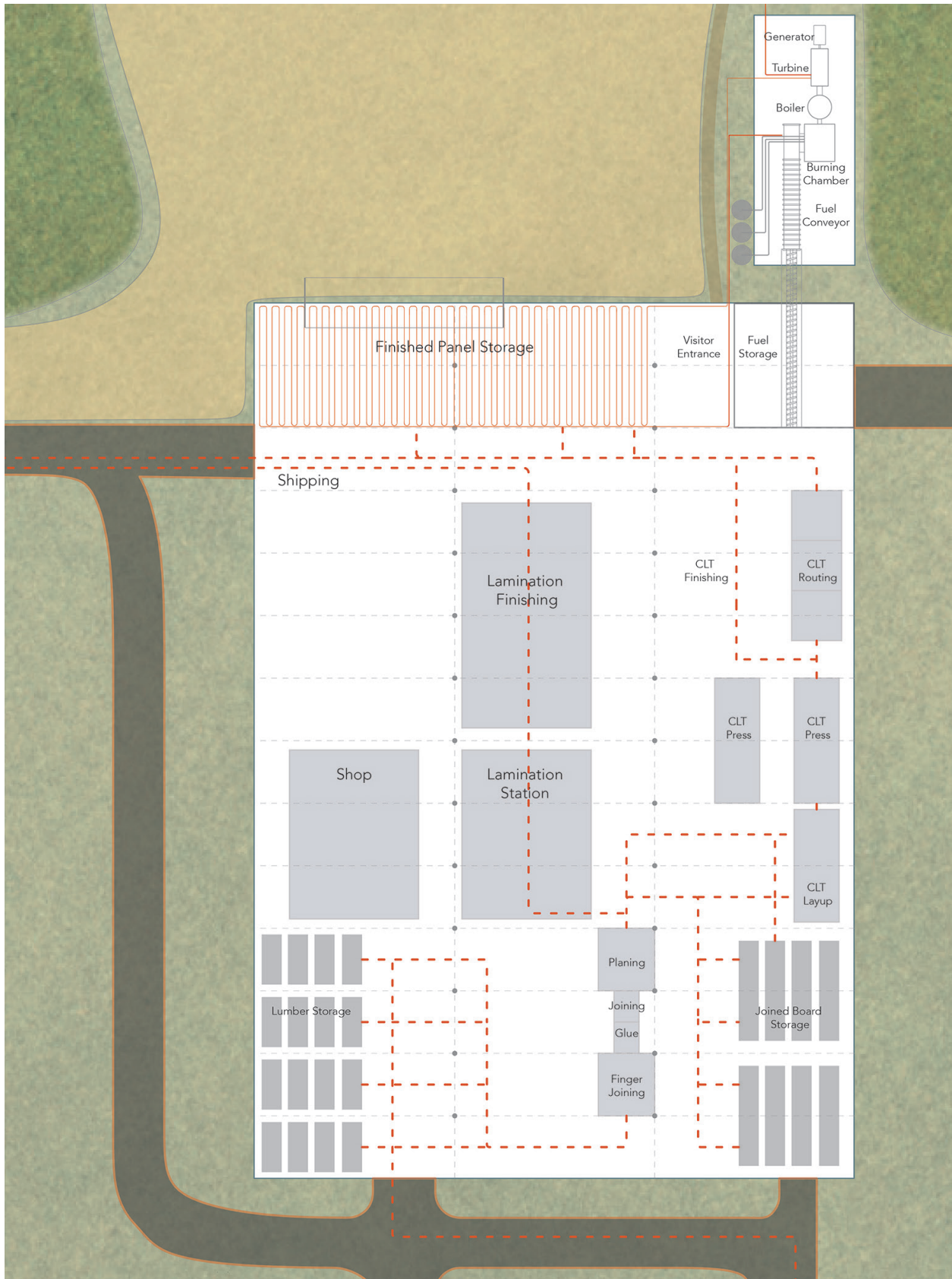


Fig 3.13: A layout of the production facility.

Glue laminated beams have a long tradition in Pacific Northwest regional architecture. The production of glulam beams requires little in addition to what is needed to fabricate CLT. Creating the two products in parallel offers a lot of potential reciprocity between adhesive technology and manufacturing techniques. The production of glulam beams begins with the stored finger-jointed boards which are manually glued and placed in large clamps. These clamps are configured for the desired dimension, and the composite beam remains clamped until the glue is finished setting. The finished beam is sent through a planer or is finished by hand in the lamination finishing area. The finished beams are also stored in the storage area at the north end of the warehouse where they await shipping.

Offcuts and sawdust from these two processes are moved to the hog fuel storage bay at the northeast end of the warehouse. Here, a door on the building's exterior, allows for the delivery of hog fuel from the sawmill. The room is heated to ensure that the wood chips stay dry. From here an auger transports the fuel into the adjacent biomass cogeneration facility. The fuel continues along a conveyor built until it reaches the boiler, where the fuel is incinerated in order to convert water into steam. The resulting steam drives a turbine, which in turn powers a generator. Power from the generator feeds into the production facility and the Center for Wood Innovation. The residual steam is used to heat water that courses through concrete slabs, providing radiant heat in both buildings.



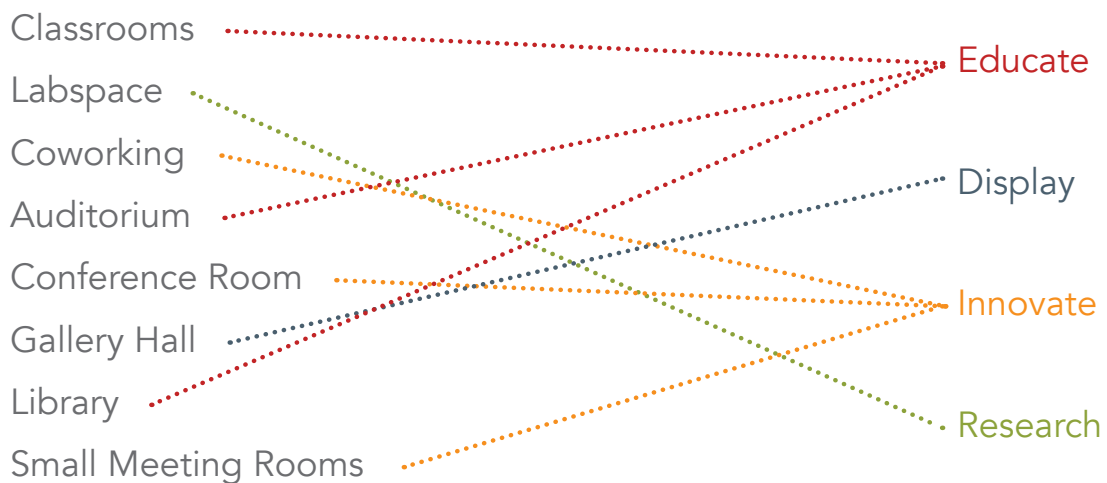
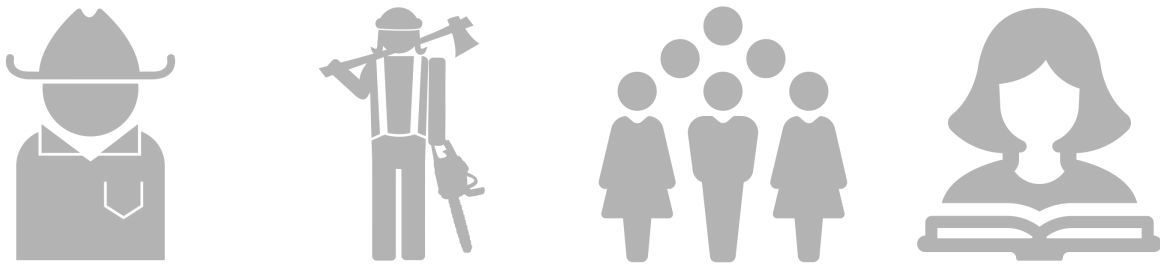
## *The Prairie*

Just as the town of Forks is built on the prairie at the edge of the forest, the production facility, cogeneration plant, and West End Center for Wood Innovation are organized around a central prairie. Upon arrival visitors are met with this clearing establishing a visual connection to both the production facility and the Center for Wood Innovation. This serves as a transition space and creates a buffer between the noise and commotion of the production facility and the center. A large aperture in the north end of the warehouse, corresponds with the panel storage area, providing a window into the production facility. A corten steel fin folds down the facade of the warehouse and cuts across the prairie providing a visual cue for the visitor's entrance to the facility. From this initial vantage point, the entrance to the Center for Wood Innovation is also visible to the right.

The introduction of a CLT manufacturing facility in Forks could diversify the existing timber industry, return jobs to an underutilized workforce, and encourage a shift towards

a more balanced approach to forestry in the region. However, the production of a new and exciting product should not be seen as a cure-all for the current problems. With the onset of this new facet of the industry, there is a continued need to look forward, anticipate the needs of the building industry, and innovate.

The Center for Wood Innovation seeks to promote this continued advancement of wood technology through education, research, and collaboration. The center aims to bring together industry leaders, loggers, policy makers, students, and the public together under one roof. The program includes classrooms, lab space, coworking space, an auditorium, conference rooms of various sizes, a gallery hall, and a small library, to support the center’s mission to educate, research, display, and innovate.

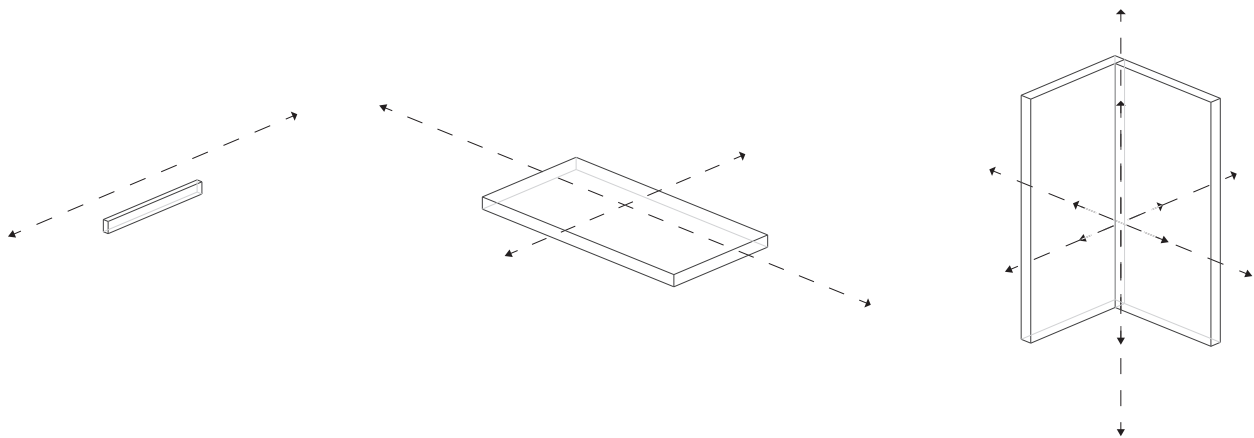




---

## West End Center for Wood Innovation

The Center for Wood Innovation is a facility that exists to bring together industry leaders, the public, policy makers, and students together in one place. In an effort to encourage individuals from differing backgrounds to see the forest from multiple perspectives. The project proposes to accomplish this by promoting education, research, innovation, and sharing of information through various components of the program. In addition to these goals, this building aims to exhibit the capabilities of CLT through its structure and its use, creating a variety of spatial experiences with one material. One way is through folding.



*Fig 4.1: CLT has the ability to span and support loads in two dimensions. By folding or joining two panels together, the system is able to withstand loads in three dimensions.*

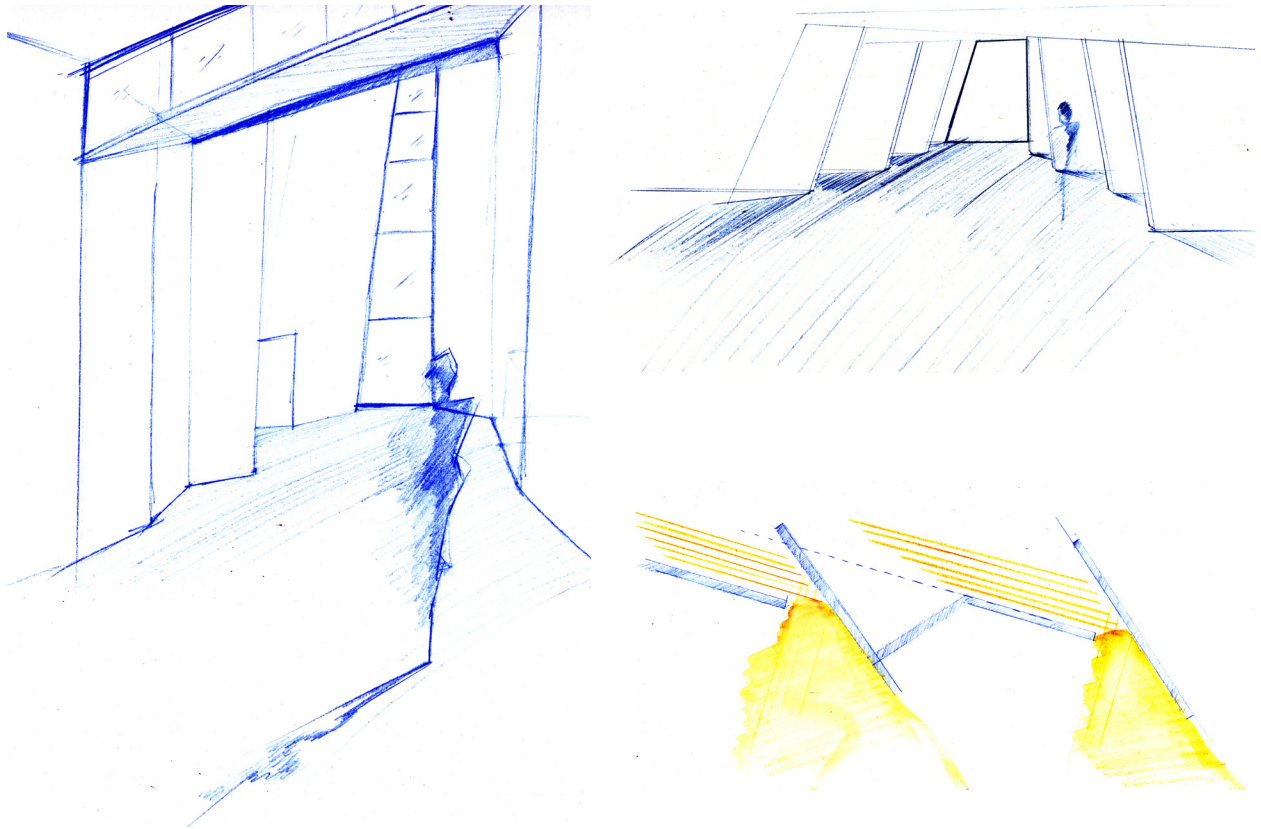
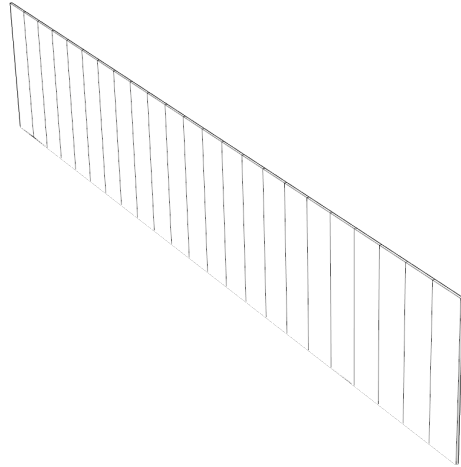


Fig 4.2: Sketches from precedents utilizing folded panels. Left: Bellevue First Congregational Church (Atelierjones) Upper Right: Temporary Chapel (Danilo Mondada) Lower Right: Conceptual light sketch.

## Folding Panels

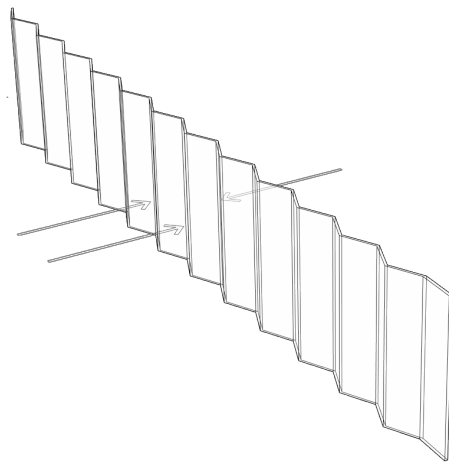
Because CLT is comprised of members which run in two, perpendicular directions, the entire panel inherits the ability to span in these same two directions. When two panels are joined together they form an assembly that has structural depth in a third direction, giving the system the ability to span in three dimensions. This principal is used to organize and enclose spatial volumes throughout the facility. CNC (Computer Numerical Control) routing gives manufactures the ability to customize panels in three dimensions with a high degree of precision. One opportunity created by CNC routing is the ability to chamfer or bevel panel edges. The creation of precise edges gives designers the flexibility to join panels at a variety of angles, creating a variety of spatial and structural implications.

## Building Organization

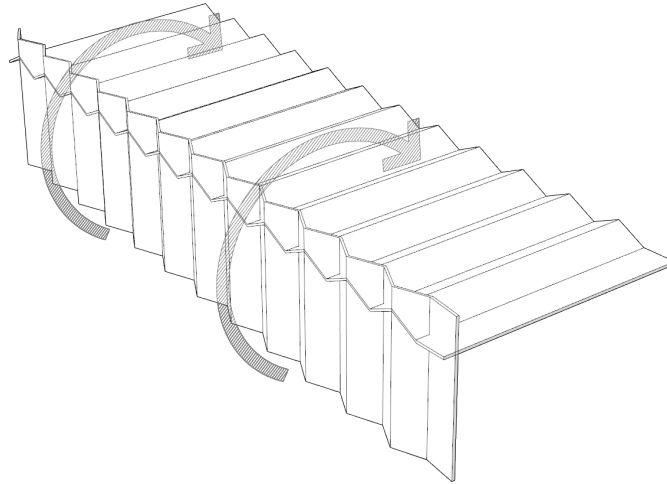


*Fig 4.3: A central wall of CLT forms a spine which divides two blocks of program.*

The building's program is organized around a central spine of vertical, CLT panels. With the panels in a straight line, the system lacks lateral support, and is dependent on additional structure for buttressing. 'Folding' the panels creates structural depth within the wall, providing lateral stability.

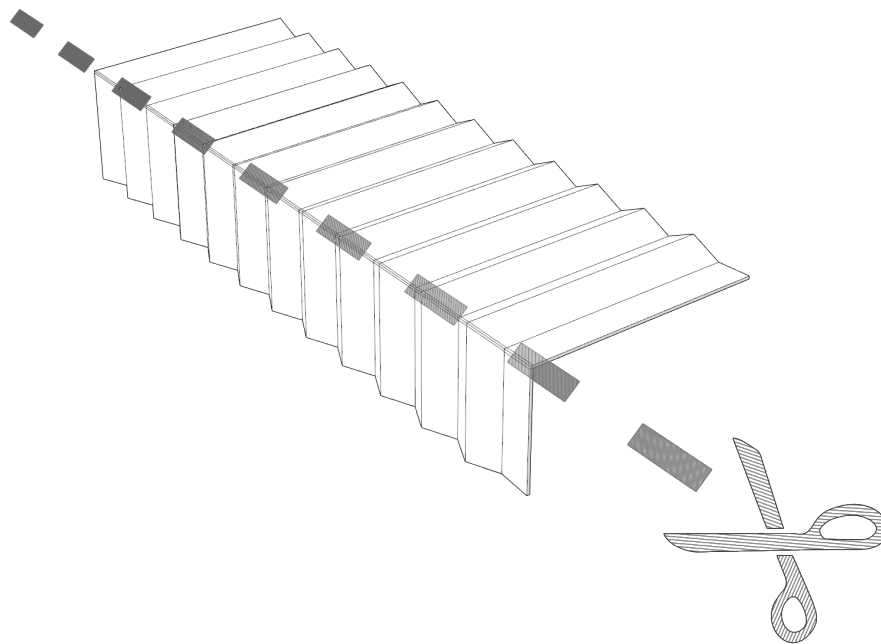


*Fig 4.4: The panels are folded to create structural depth and lateral stability.*

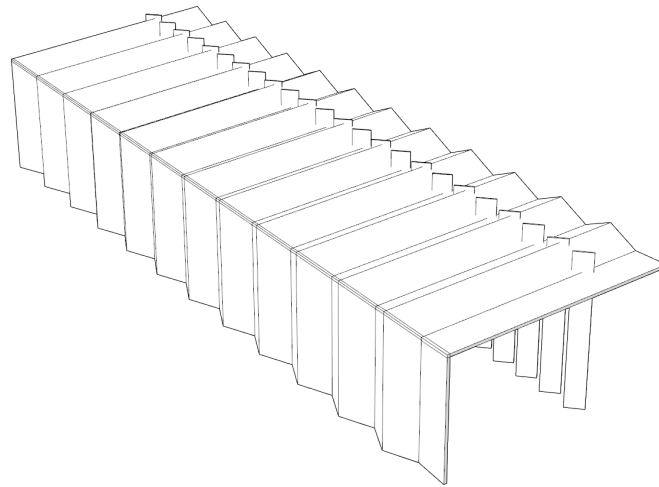


*Fig 4.5: The spine is rotated to great a volume for the gallery hall.*

The spine is copied and rotated to create a large volume for the gallery hall. With the system acting as a roof rather than a wall, the folding panels act like beams to span the large space. The depth created by this fold provides greater resistance to bending and deflection than would be afforded by a flat panel.

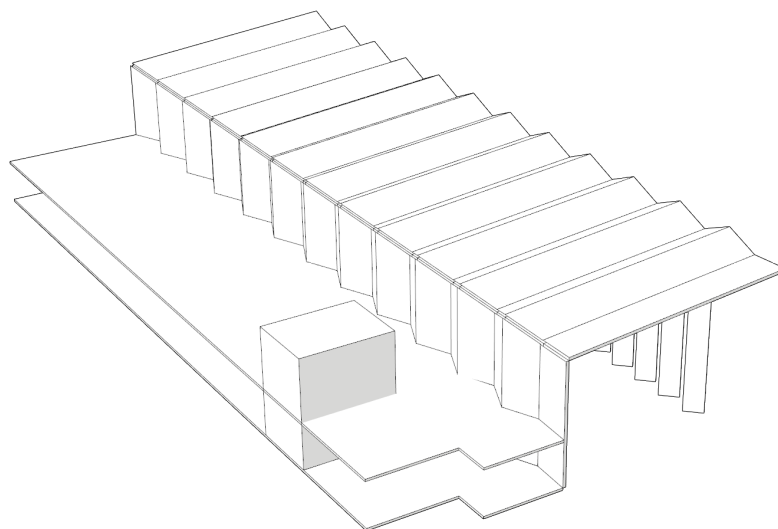


*Fig 4.6 : CNC routing allows for beveling the panel edges, maximizing the surface area for joining panels.*

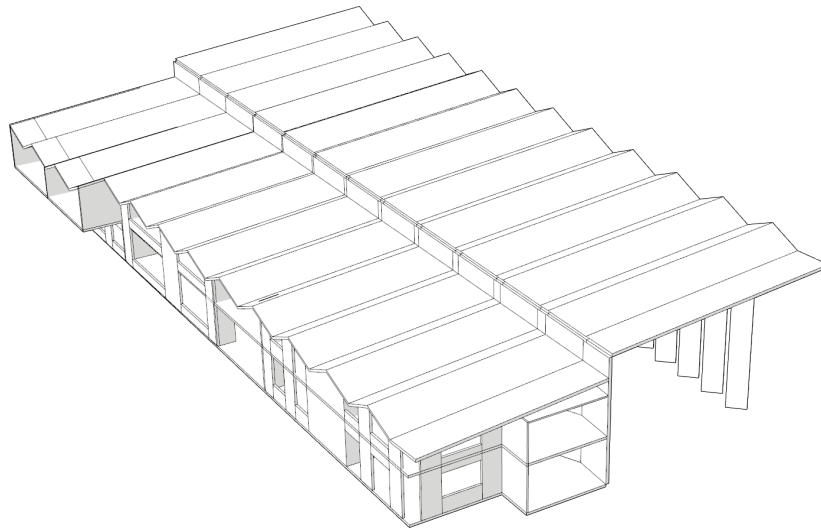


*Fig 4.7: CLT fins supports the roof at each crest and trough.*

CLT fins support the roof at each crest and trough. The fins also serve to modulate northern light as it spills into the gallery space. An extension of the roof provides enclosure for the ramp area, which wraps around the column line. A continuous CLT diaphragm is added to the opposite side of the spine, creating two levels in the second bar, and providing structural continuity. A CLT core encloses bathrooms on both levels, and adds lateral support. The core provides support for a stair, but does not contain an elevator. Accessible, vertical circulation takes place along the ramp on the opposite side of the gallery.

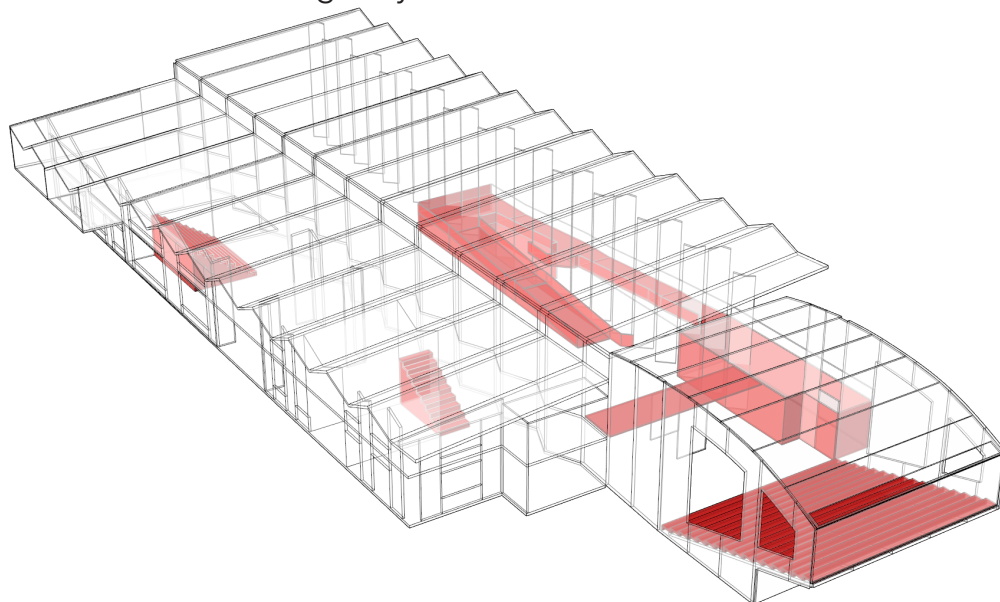


*Fig 4.8: The panels are folded to create structural depth and lateral stability.*



*Fig 4.9: Walls comprised of vertical and horizontal CLT panels articulate various programmatic blocks.*

Vertical CLT panels are organized around and throughout the second level to articulate programmatic blocks. These vertical panels act as columns to support the addition of a folded roof, as horizontal panels act as beams to accommodate windows. These large apertures permit light to penetrate deep into the space, while an extension of the roof shades the glazed surfaces from the extreme summer sun. A ramp wraps around the gallery's CLT fins, while two sets of stairs assist with vertical circulation in the second block. An auditorium extends the gallery.



*Fig 4.10: Circulation and an auditorium are added.*

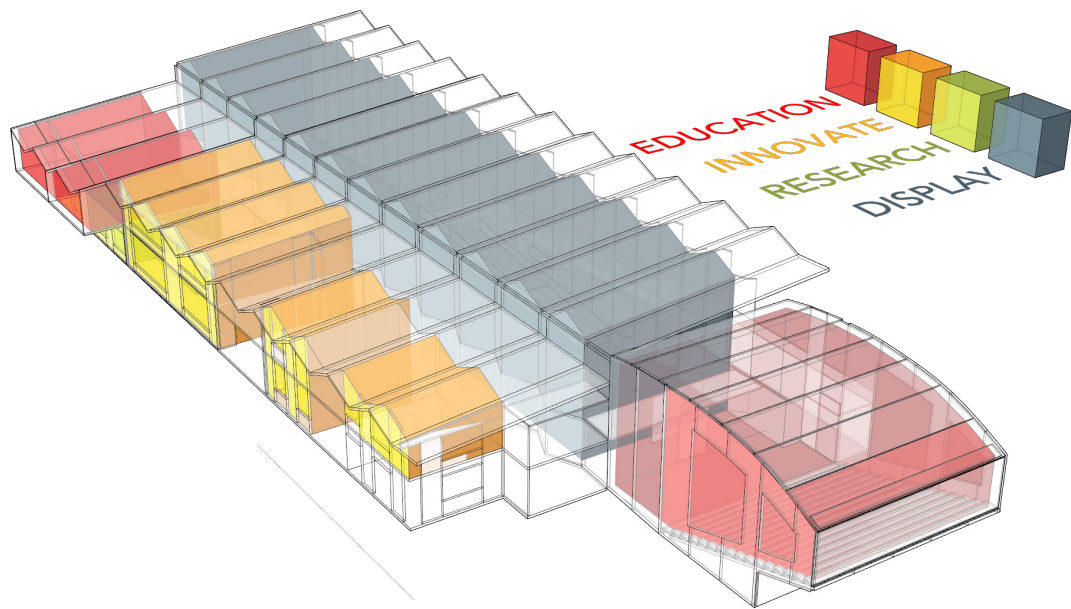


Fig 4.11: Program Diagram

## *Program Blocks*

The building's program is divided between the four goals of educating, innovating, researching, and displaying information. Education, innovation, and research spaces are organized within the second area of program and face south, out onto the prairie and across from the production facility. Two classrooms sit at the far end of the second level, cantilevering over the two laboratory spaces below. The auditorium acts as an additional classroom and lecture hall. A large conference room sits atop the administrative space, nearest the entrance, and four small meeting rooms are clustered on the other side of the bathroom core. A large co-working space span both levels and sits adjacent to the classrooms.

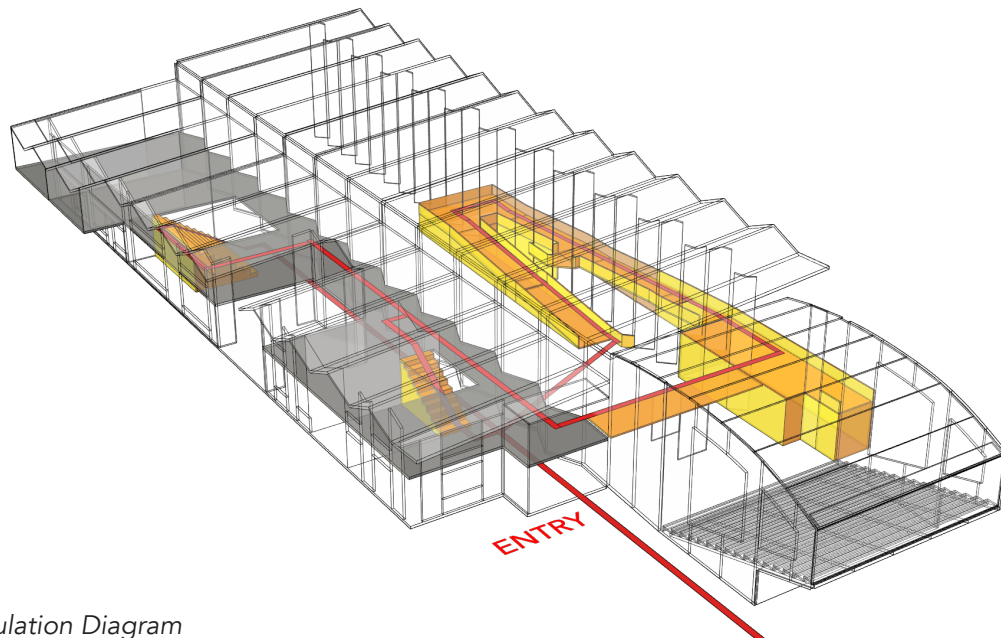


Fig 4.12: Circulation Diagram

## *Circulation*

Visitors enter the Center for Wood Innovation alongside the auditorium, covered by a projecting walkway on the second level. Upon entry visitors have the option of passing through the spine into the gallery, taking the first set of stairs to the second level, or walking straight ahead to the collaborative working area or labs. The rhythm of folding panels is punctuated by two large openings that allow visitors to flow through the spine at the beginning and end of the gallery. One end of the gallery opens into an expansive view of the forest, while the other extends into the auditorium. A set of panel doors slides away to create a continuous space between these two volumes. From the gallery, visitors circulate around the row of CLT fins as they climb to the second floor. Three landings allow for people to pause at points along the way, and observe the space from a variety of vantages. From the top of the ramp, guests walk above the auditorium's sliding wall, and through the building's spine to the second block. Circulation through the second level occurs alongside the building's spine. A second set of stairs at the end of the hall, doubles as an informal gathering space.

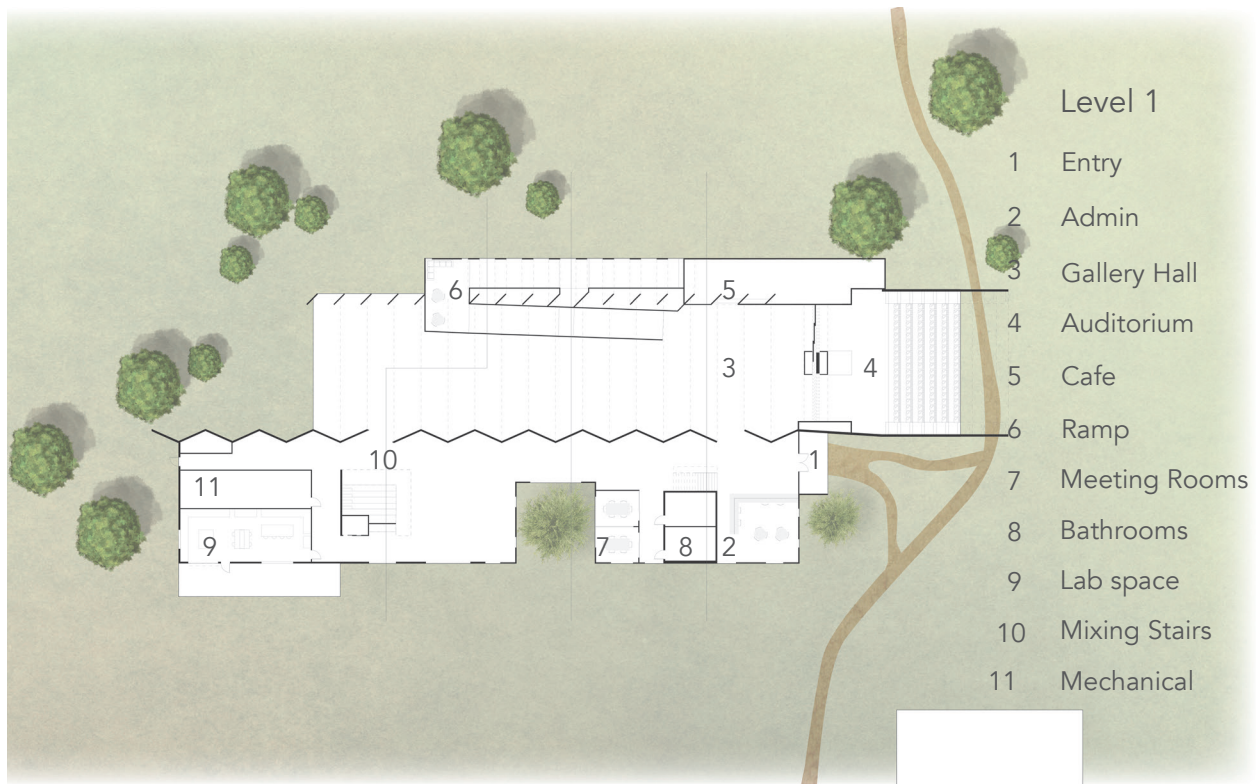


Fig 4.13: Level 1 Plan

### *Spatial Order in Plan*

The building's various adjacencies are more easily read in plan. The administrative area, including a receptionist desk greets visitors upon arrival. Two gaps in the spine shows where openings allow for the flow of visitors. Between the auditorium, a sliding panel wall tucks away into the backdrop of the lectern. The cafe is located within the gallery at the base of the ramp. A landing midway up the ramp and another at the top provide seating for the cafe. A square courtyard is inset between two small conference rooms and the lower level of the collaborative working space. A lab space is located at the far end of the plan, with easy access to the mechanical room and exterior working space. Across the hallway from the mechanical room, a chase fits into the structural depth of the spine, allowing for the vertical passage of ventilation and hot water for the upper level radiant floors.



Fig 4.14: Level 2 Plan

At the east end of the 2nd level a large conference room overlooks the entrance and greets guests passing through the central spine. The bathroom core separates this large conference room from the cluster of small conference rooms. These smaller rooms are stacked above their first level companions and are likewise situated next to the courtyard. Across the walkway from the courtyard, a small prow establishes a visual connection to the gallery hall. The collaborative working space is comprised of a variety of desk and seating options (4), a small library (5), and a large staircase that doubles as a social space (6). Two large classrooms sit at the end of this area and open out onto the prairie and the production facility.

## *Spatial Sequence*

### *Arrival & Entry*

Visitors approach the Center for Wood Innovation alongside the auditorium. This initial view provides a glimpse of the auditorium, large conference room, and the upper-level walkway. An extension of this walkway creates a covered entrance to the facility. The charred siding of the auditorium is accented with an exposed panel, displaying the name of the building and the precision of the facilities CNC router.

Visitors can proceed from the entry by taking the stairs to the second level or passing through an opening in the spine. The steps of the entry stair are supported between the CLT core and a panel set at a diagonal to follow the slope of the stairs. A bench built into the recess of one of the wall's folds shows the structural depth of the spine.

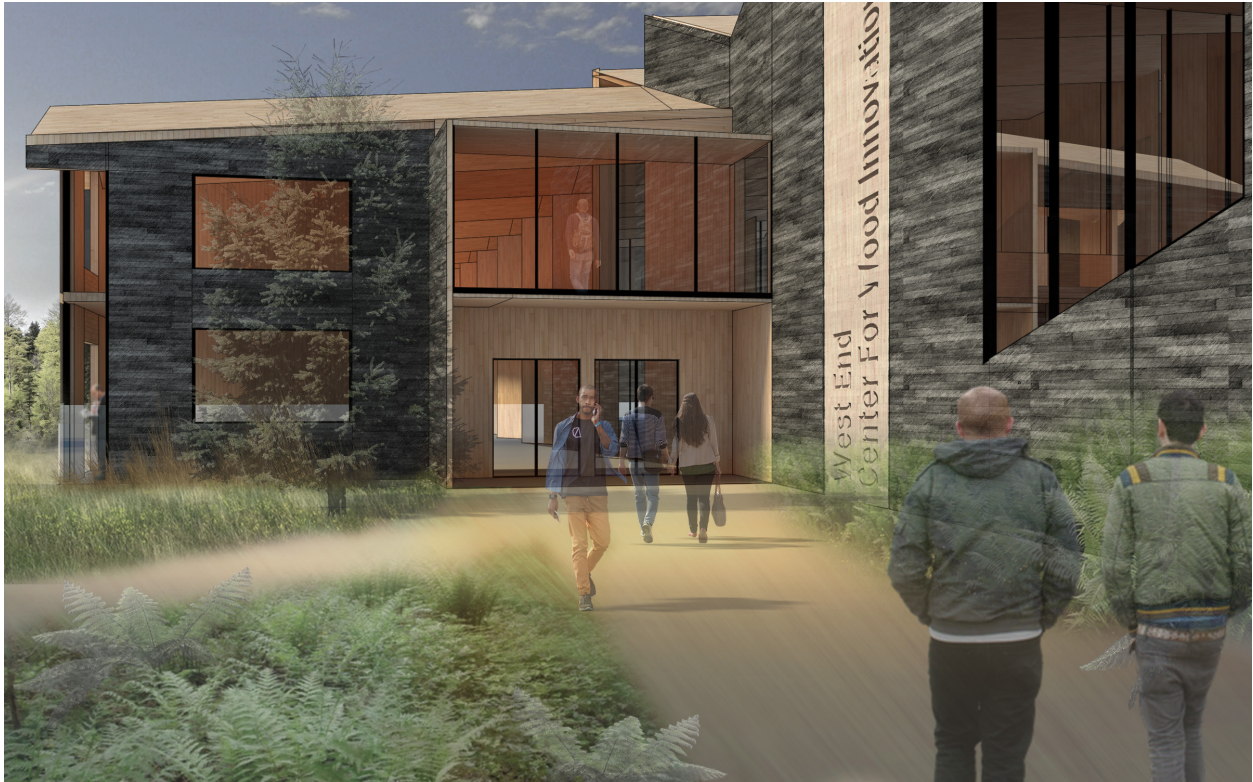


Fig 4.15: West End Center for Wood Innovation - Approach + Entry



Fig 4.16: West End Center for Wood Innovation - Entry

## *Gallery & Ramp*

After passing through the central spine, visitors enter the gallery hall where displays expose visitors to various dimensions of forestry and forest products. Exhibits could include a typical CLT panel and the equivalent dimensional lumber and raw logs used to make an identical panel, hinged panels with routed niches for digital displays, or full scale mock ups of innovative CLT connections. The undulating CLT ceiling is punctuated by light wells, which wash the vertical wall with daylight. This helps get light deep into the space and balances diffuse light which pours in from the glazed, northern facade. This light is further modulated by the array of fins that are rotated 45 degrees in order to maximize surface area for supporting the roof above. Upon entering the gallery, the fins create the appearance of a solid wall, and as visitors circulate to the rear of the gallery, they are permitted an increasingly open view of the forest beyond the northern facade. A reciprocal opening at the west end of the gallery hall allows visitors to circulate through the space and out the far side of the gallery. Alternatively, people can proceed to the second level along the ramp, which wraps around the fin wall.

The ramp takes visitors alongside the fins and the spaces between, which are planted with common under story plants including: Sword ferns, stair-step moss, Oregon oxalis, salmonberry, and huckleberry.<sup>1</sup> The first landing along the ramp has tables and chairs providing an informal meeting place near the cafe. Continuing up the ramp, the next landing juts out between two of the fins, creating a porch for visitors to look out over the atrium. The final landing provides various seating options and a small reading area looking out onto the gallery, auditorium, and forest.

---

<sup>1</sup> "Temperate Rain Forests - Olympic National Park (U.S. National Park ...." <https://www.nps.gov/olymp/learn/nature/temperate-rain-forests.htm>. Accessed 10 Dec. 2016.



Fig 4.17: Gallery Hall



Fig 4.18: View Along Gallery Hall Ramp

## *Collaborative Workspace*

This section shows the spatial connection between the collaborative working space, mixing stairs, gallery, and ramp. The mixing stairs double as vertical circulation and an informal meeting space, and contribute to spatial continuity between the two levels. The structure of the stairs is comprised of CLT panels which span from the first floor to the second, and are supported midway by the back wall of a small niche beneath the assembly. At the base of the stairs, an opening in the spine allows visitors to move between the gallery and collaborative working space. The drawing also points to the ramp's spatial implications in the gallery as it divides the vertical plane into three parts. Light wells are located on either side of the spine, washing light on the vertical surface and introducing daylight into the interior zones.

The vignette of the mixing stairs shows their relationship to the collaborative working space. Classrooms, conference rooms, and a small library are adjacent to this area, making it an ideal space for students to study and for various groups to come together and meet. Classrooms, conference rooms, and bathrooms capture the most daylight along the southern wall, while circulation runs alongside the central wall. The continuous hallway assists with wayfinding, and allows for visitors to see the various parts of the second level in a single glance. Large light wells help to uniformly daylight the space.

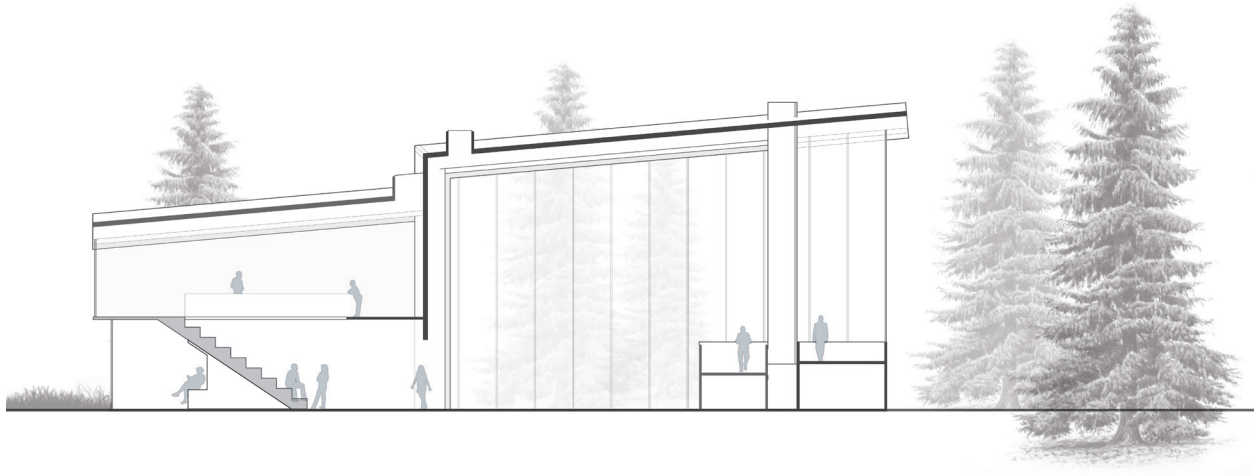


Fig 4.19: Section cut through mixing stair, collaborative working space, gallery hall, and ramp.



Fig 4.20: Mixing stairs and collaborative working space.

## *Auditorium*

While the forest surrounds the building to the west and north, the southern facade looks out over a prairie that fills the space between the Center for Wood Innovation and the production facility. Figure xx shows a square courtyard inset along the southern facade, bringing light into the conference rooms and opening working space. A western hemlock, planted at the center of the courtyard marks the passage of time since the building's completion, and indicates the edge of the experimental forest. Behind the courtyard, the section shows the extension of the classrooms over the lab space below. This cantilever provides additional classroom space, and shelters an exterior extension of the lab. A portal through the central spine opens onto a small overlook, providing a visual connection between the courtyard, corridor, gallery, and the ramp. Mirrored on the opposite of the gallery is a small prow, which protrudes between two CLT fins.

The auditorium sits at the eastern end of the gallery space, and is separated by a sliding panel wall, which hangs from the underside of the walkway above. Similar to the mixing steps, the stepped seating area is comprised of slanted CLT panels that are anchored in the floor and rest upon a wedge shape base, before cantilevering over the path between the parking lot and entrance. The auditorium can be open to act as an extension of the gallery, or closed to create additional classroom space or a lecture hall. The nearest movie theater is an hour away in Port Angeles. At night, the auditorium can be used as a movie theater with a screen rolling down to cover the west wall.



*Fig 4.21: The auditorium - An extension of the gallery hall, and a place for lectures, classes, and movies.*

---

## Conclusion

Washington's Olympic Peninsula is home to some of the most beautiful landscapes in the country. The lush forests that populate this region are a critical part of the region's ecology and at the same time, provide the economic foundation for timber communities such as Forks. This dichotomy has historically been a source of conflict, leading to the assumption that these two perspectives are mutually exclusive. This thesis suggests a path forward that consists of a more cohesive, symbiotic solution, which promotes healthy forest ecologies, while reviving an industry that once provided many of the region's best paying jobs. The proposal offers a new model, merging production, forests, and education in a single site. To this end, the proposed West End Center for Innovation includes a CLT production facility, experimental forest plots, and an educational center. The hope is that combining these three elements in one site will foster innovation, the exchange of ideas, and a unified vision for the future of forests and the communities that depend on them.

Several objectives guided this exploration: demonstrating the process of CLT production from forest to panel, creating opportunities for industry and the public to overlap, and exhibiting the structural, spatial, and aesthetic potential of a new material. The proposal includes a sequence of experiences that expose visitors to the latest forestry practices through an experimental forest, real time fabrication of CLT in the production facility, and finally the Center for Wood Innovation, a public facility where these ideas can coalesce.



# Works Cited

---

## Building Industry

Carpenter, Anne. 2012. CO2 abatement in the cement industry. IEA Clean Coal Centre

Oliver, CD., Nassar, NT., Lippke, BR., & McCarter, JB. (2014). Carbon, Fossil Fuel, and Biodiversity Mitigation with Wood and Forests. *Journal of Sustainable Forestry*, 33(3), 248-275

Anderson, Jason, Malcolm Fergusson, and Carolina Valsecchi. 2008. "An Overview Of Global Greenhouse Gas Emissions And Emissions Reduction Scenarios For The Future," European Parliament, Policy Department Economic and Scientific Department, p. 11.fafac

## Cross Laminated Timber

Mayo, Joseph. *Solid Wood*. Place of Publication Not Identified: Routledge, 2015.

Thompson, Henrietta. *A Process Revealed = Auf Dem Holzweg*. London: Murray & Sorrell, 2009.

Council, Binational Softwood Lumber. *CLT Handbook: Cross-laminated Timber, Vol. 1*. Erol Karacabeyli & Brad Douglas. FPIInnovations, 2013, 6.

Gagnon, S, and E Karacabeyli. "Status of cross-laminated timber construction in North-America." *Structures and Architecture: New concepts, applications and challenges* (2013): 66.

[D'Errico, Hannah, Shmulsky, Rubin, Gallo, Warren, and Montague, Iris. Tall, Cross-laminated and Massive Timber Buildings: A United States Perspective, 2016, ProQuest Dissertations and Theses.](#)

"Mass timber rising | Oregon Forest Resources Institute." Accessed December 15, 2016. <http://oregonforests.org/blog/mass-timber-rising>.

Pei, Shiling, Douglas Rammer, Marjan Popovski, Tom Williamson, Philip Line, and John W. van de Lindt. "An Overview of CLT Research and Implementation in North America." (2016).

D.R. Johnson Wood Innovations & CLT - Oregon CLT." Accessed December 15, 2016. <http://oregonclt.com/about/>.

## Forestry

Berry, Wendell. *Another Turn of the Crank Essays*. Washington, DC: Counterpoint, 1996.

Pandey, Deep Narayan. *Beyond Vanishing Woods: Participatory Survival Options for Wildlife, Forests, and People*. Udaipur: Himanshu Publications, 1996.

K.E Stein, et al., *Community and Quality of Life*(Washington D.C.: National Academies Press, 2002), 32.

Simonen, Kathrina. *Life Cycle Assessment*. Florence: Taylor and Francis, 2014.

"About the Washington Department of Natural Resources | WA - DNR." About the Washington

Department of Natural Resources | WA - DNR. Accessed December 12, 2016. <http://www.dnr.wa.gov/about-washington-department-natural-resources>.

## Forks

Dietrich, William. *The Final Forest: Big Trees, Forks, and the Pacific Northwest*. Seattle: University of Washington Press, 2010.

Morgenroth, Chris, and Katherine Morgenroth. Flaherty. *Footprints in the Olympics: An Autobiography*. Fairfield, WA: Ye Galleon Press, 1991.

"Olympic Peninsula Community Museum - Online Exhibits - Homesteaders and Pioneers."  
Homesteaders and Pioneers. Accessed May 21, 2016. <http://content.lib.washington.edu/cmpweb/exhibits/homesteading/index.html>.

Douglas, William Orville. *The Last Frontier in a Dark Forest: Forks, Washington*. publisher not identified, 1964.

Russell, Jervis. *Jimmy Come Lately, History of Clallam County: A Symposium*. Jervis Russell. Clallam County Historical Society, 1971.

Amundson, Mavis. *The Great Forks Fire*. Western Gull Pub., 2003.

Buttolph, Lita P et al. "Northwest Economic Adjustment Initiative Assessment: Forest Community Research. Forks, Clallam County, Washington." (2006).

Ollikainen, Rob. "Timber Left Standing on Department of Natural Resources Trust Lands While Peninsula Mills Shut down." Peninsula Daily News. June 12, 2015. Accessed May 17, 2016. <http://www.peninsuladailynews.com/article/20150612/NEWS/306129967>.

"Recent mill closures and Allen Logging Co. - Peninsula Daily News." 2015. 17 may. 2016 <<http://www.peninsuladailynews.com/article/20150612/NEWS/306129967>>

"The Spotted Owl's New Nemesis | Science | Smithsonian." 23 April. 2016 <<http://www.smithsonianmag.com/science-nature/the-spotted-owls-new-nemesis-131610387/>>

## First Nations History

"Quileute Nation History." Quileute Nation. Accessed April 30, 2016. <http://www.quileutenation.org/history>.

Ruby, Robert H, and John Arthur Brown. *Indians of the Pacific Northwest: A history*. University of Oklahoma Press, 1988.

Reagan, Albert B. "Plants used by the Hoh and Quileute Indians." *Transactions of the Kansas Academy of Science (1903-)* 37 (1934): 55-70.

## List of Figures

---

\*All images were taken or created by the Author unless noted below

1. The Olympic Mountains. 2016. Wikimedia.org, Hood Canal.  
Trail in the Hoh Rainforest  
Prairie North of Forks, WA  
Sea Stacks at Second Beach, La Push, WA
2. Global CO2 Emissions from Manufacturing & Construction
3. Global Industrial Emissions
4. Prairie Along Highway 101 North of Forks, WA
5. Olympic Peninsula Hillshade
6. "Spruce Production Division Logging." Digital image. Craig Magnuson. Accessed Autumn 2016. <http://www.craigmagnuson.com/spdrr01.htm>.
7. Olympic Peninsula Hillshade showing 101 and major population areas.
8. Forks Timber Museum. "Looking north through Forks in 1916"
9. Forks Timber Museum. "Looking north through Forks in 1916"
10. Fork Timber Museum. "Downtown Forks during the opening of the Olympic Loop Highway (101) in 1931"
11. Forks Timber Museum. "A road cuts through the dense forest just outside of Forks."
12. 1951 file photo. Mr and Mrs. John Maxwell sprinkle water on the ruins of their nine-unit auto court. Digital image. Accessed Autumn 2016. [www.seattletimes.com/seattle-news/fire-in-olympics-now-at-400-acres-moving-through-tree-tops/](http://www.seattletimes.com/seattle-news/fire-in-olympics-now-at-400-acres-moving-through-tree-tops/).
13. Beebe, Sam. Port of Longview, Washington. Digital image. Spring 2008. Accessed Autumn 2016. <https://commons.wikimedia.org>.
14. Sam Beebe. "Clearcut." Digital image. Accessed Autumn 2016. <https://www.flickr.com/photos/sbeebe/5225636134>.
15. "Who Gives a Hoot?" [http://img.timeinc.net/time/magazine/archive/covers/1990/1101900625\\_400.jpg](http://img.timeinc.net/time/magazine/archive/covers/1990/1101900625_400.jpg), [http://img.timeinc.net/time/magazine/archive/covers/1990/1101900625\\_400.jpg](http://img.timeinc.net/time/magazine/archive/covers/1990/1101900625_400.jpg)
16. Block, Herb . "'Damn Owl!'" Cartoon. 1990.
17. "Save a logger, eat an owl." <http://www.washington.edu/uwired/outreach/cspn/Website/Classroom%20Materials/Curriculum%20Packets/Evergreen%20State/Section%20II.html>
18. Olympic Peninsula With Forest Ownership Overlay.
19. DNR Experimental Forest Treatment North Of Forks, WA.
20. A Sign On Privately Held Timberland Along Highway 101, Just North Of Forks.
21. Remnants Of The Debarking Station At The Beaver Division Of The Interfor Mill.
22. An Vacated Planing Warehouse At The Forks Division Of The Interfor Mill.
23. Commercial Forests Flank Highway 101, Between Forks And Crescent Lake.
24. Shift In Industry Diagram
25. CLT Layup Diagram
26. CLT Benefits Diagram
27. Reworks Inc. Albina Yard Photos. [www.reworksinc.com](http://www.reworksinc.com)
28. Michael Green Architecture. Wood Innovation and Design Centre. <http://mg-architecture.ca/>
29. AtelierJones. Bellevue First Congregational Church. [www.atelierjones.com](http://www.atelierjones.com)

30. Aerial View of DRJohnson Lumber Co.
31. "The Wizard" An Employee Adds a Rusticated Finish to a Glulam beam.
32. CLT Press at DRJohnson
33. CNC Router at DRJohnson Lumber
34. Current CLT Manufacturers in the Pacific Northwest.
35. Satellite Image of Washington's Olympic Peninsula
36. Hillshade Highlighting Clallam County
37. A Logging Truck Trundles Along Highway 101 Through Downtown Forks. <http://www.destination360.com/north-america/us/washington/forks>
38. Forks Context Analysis
39. Forks Context Analysis With Forest Ownership
40. Axonometric Diagram of Forks, WA
41. Site Analysis Diagram
42. Legacy Trees Dot The Clearcut Forestland North Of The Site.
43. The Existing Warehouse From The Southeast Corner Of The Forks Industrial Park.
44. Vacant Interfor Warehouse
45. Site Plan Of The Proposed West End Center For Wood Innovation
46. Photo Montage of a Tour Through the Experimental Forest
47. Enlarged Site Plan Emphasizing the Bloedel Experimental Forest
48. View of Panel Storage and Shipping Area
49. Production Facility Process Diagram
50. Looking Across the Prairie to the Production Facility.
51. Program Diagram
52. Panel Axes Diagram
53. Early Sketches and Diagrams
54. Innovation Center Diagrams: Spine
- 55: Innovation Center Diagrams: Spine Folded
56. Innovation Center Diagrams: Spine Rotated to Form Roof
57. Innovation Center Diagrams: Trimmed Connection
58. Innovation Center Diagrams: Addition of Fin Wall
59. Innovation Center Diagrams: Addition of Floors and Core
60. Innovation Center Diagrams: Walls Articulate Spaces
61. Innovation Center Diagrams: Addition of Circulation Elements and Auditorium
62. Innovation Center Diagrams: Program Blocks
- 63: Innovation Center Diagrams: Circulation
- 64: Innovation Center: Level 1
- 65: Innovation Center: Level 2
- 66: Innovation Center: Approach and Entry
- 67: Innovation Center: Entry
- 68: Innovation Center: Gallery Hall
- 69: Innovation Center: View Along Gallery Ramp
- 70: Innovation Center: Section Through Coworking Space
- 71: Innovation Center: Mixing Stairs and Collaborative Working Space
- 72: Innovation Center: Auditorium