

Cultivating Workplace Well-being:  
A Living Office Renewal

Yue Deng

A thesis  
submitted in partial fulfillment of the  
requirements for the degree of

Master of Architecture

University of Washington

2017

Committee:  
Rob Peña  
Heather Burpee

Program Authorized to Offer Degree:

Architecture

©Copyright 2017

Yue Deng

University of Washington

Abstract

**Cultivating Workplace Well-being:  
A Living Office Renewal**

Yue Deng

Chair of the Supervisory Committee:

Associate Professor, Rob Peña

Department of Architecture

Many contemporary tech industry office buildings are designed so that they isolate workers from nature. Exposure to nature is beneficial to human well-being, especially to social, psychological, and physical well-being. Research demonstrates that modern office building design is harmful to workers, often in measurable ways. By retrofitting a building to integrate nature into its structure, employee well-being and productivity can be improved, to the benefit of both workers and businesses. Given the potential of many existing structures, retrofitting is the most sustainable and affordable basis to work from. Additionally, connecting a site with its context by opening some of it to the public extends these influences to a business's community. This transparency allows the features of design to cement the business's reputation as an iconoclast of environmental sustainability. As many of the problems with office building design are caused by an isolation from nature, they can be addressed by injecting nature into the structure. This project proposes doing so by utilizing several methods of improvement: opening the structure's envelope with operable windows, curtain walls, light wells, and balcony and patio spaces; enabling circulation of fresh air and adding light wells to improve spatial quality; creating gardens, greenhouses, and outdoor lounges to serve as attractive opportunities for green exercise; and designating spaces for focus work as well as collaborative work to improve mood and productivity. The main philosophy of this thesis is to invite nature within a structure to take advantage of the benefits nature can provide to workers while remaining environmentally conservative.

I would like to express my gratitude to my friends and family for their tremendous and infinite support, my thesis committee for their valuable contributions, and Tess Milom for her indispensable help as a tutor.

# Table of Contents

Table of Contents	5
List of Figures	6
Chapter 1 Introduction	10
Chapter 2 Nature and Well-being	15
Chapter 3 Cultivating Well-being	23
Chapter 4 Design Proposal	33
Chapter 5 Conclusion	48
Bibliography	49

# List of Figures

Fig. 1: *Something Somewhere Went Terribly Wrong* - Source: <http://freshwallpapers.net/others/something-somewhere-went-terribly-wrong.html>

Fig. 2: *Photo of Hills* - Source: <https://peterlengyel.files.wordpress.com/2011/06/5mai1.jpg?w=1280&h=1978>

Fig. 3: *Photo of Forest* - Source: <https://www.carbonbrief.org/wp-content/uploads/2015/08/stock-forest-wood-england-UK-1550x804.jpg>

Fig. 4: *Photo of Lake* - Source: <https://s-media-cache-ak0.pinimg.com/736x/f5/68/a9/f568a9dfa8d513add278e37f29db8314.jpg>

Fig. 5: *Seattle Green Space vs. Tech Company Map* - Source: author.

Fig. 6: *American Time Use Survey* - Source: <https://www.bls.gov/tus/charts/>

Fig. 7: *Portland Public Service Building* - Source: [https://classconnection.s3.amazonaws.com/890/flashcards/2588890/jpg/portland\\_public1364936268391.jpg](https://classconnection.s3.amazonaws.com/890/flashcards/2588890/jpg/portland_public1364936268391.jpg)

Fig. 8: *Office Cubicles* - Source: [https://c.o0bg.com/rf/image\\_1200w/Boston/2011-2020/2015/02/26/BostonGlobe.com/Magazine/Images/p24\\_opening\\_photo.jpg](https://c.o0bg.com/rf/image_1200w/Boston/2011-2020/2015/02/26/BostonGlobe.com/Magazine/Images/p24_opening_photo.jpg)

Fig. 9: *Contemporary Open-plan Office* - Source: <https://media.licdn.com/mpr/mpr/AEEAAQAAAAAAAAAAIrAAAAJDI1MDY1MzRiLTNkMGMtNDcxNC1hNWY2LWJjNzMxYWY3M2JhYg.jpg>

Fig. 10: *The Eight Dimensions of Wellness* - Source: author.

Fig. 11: *Pasona Headquarters Facade* - Source: Kono Designs

Fig. 12: *Pasona Headquarters Interior* - Source: Kono Designs

Fig. 13: *Pasona Headquarters Plans* - Source: Kono Designs

Fig. 14: *Bullitt Center Exterior* - Source: <http://www.bullittcenter.org/building/photo-gallery/>

Fig. 15: *Bullitt Center Interior* - Source: <http://www.bullittcenter.org/building/photo-gallery/>

Fig. 16: *Bullitt Center Facade Treatment* - Source: <http://www.bullittcenter.org/building/photo-gallery/>

Fig. 17: *Dimensions of Workplace Well-being* - Source: author.

Fig. 18: *Building Layers Diagram* - Source: Brand, S. (1994). *How Buildings Learn*

Fig. 19: *Site Context Map* - Source: author.

Fig. 20: *Site Aerial Photo* - Source: Google Map

*Fig. 21: Burke Gilman Trail - Source: Google Map*

*Fig. 22: Fremont Cut - Source: Google Map*

*Fig. 23: Fremont Bridge - Source: author.*

*Fig. 24: Aurora Bridge - Source: Google Map*

*Fig. 25: Site Existing North Facade - Source: Google Map*

*Fig. 26: Site Existing West Facade - Source: Google Map*

*Fig. 27: Adobe Building Interior Cubicles - Source: author.*

*Fig. 28: Adobe Building Interior Hallway - Source: author.*

*Fig. 29: Concept Diagrams - Source: author.*

*Fig. 30: Cultivation Features - Source: author.*

*Fig. 31: Plans and Program - Source: author.*

*Fig. 32: Sections and Building Systems - Source: author.*

*Fig. 33: Aerial View - Source: author.*

*Fig. 34: Community Passage - Source: author.*

*Fig. 35: Eating Together - Source: author.*

*Fig. 36: Arrival Common - Source: author.*

*Fig. 37: Cultivate - Source: author.*

*Fig. 38: Working On The Edge Outside - Source: author.*

*Fig. 39: Working On the Edge Inside - Source: author.*

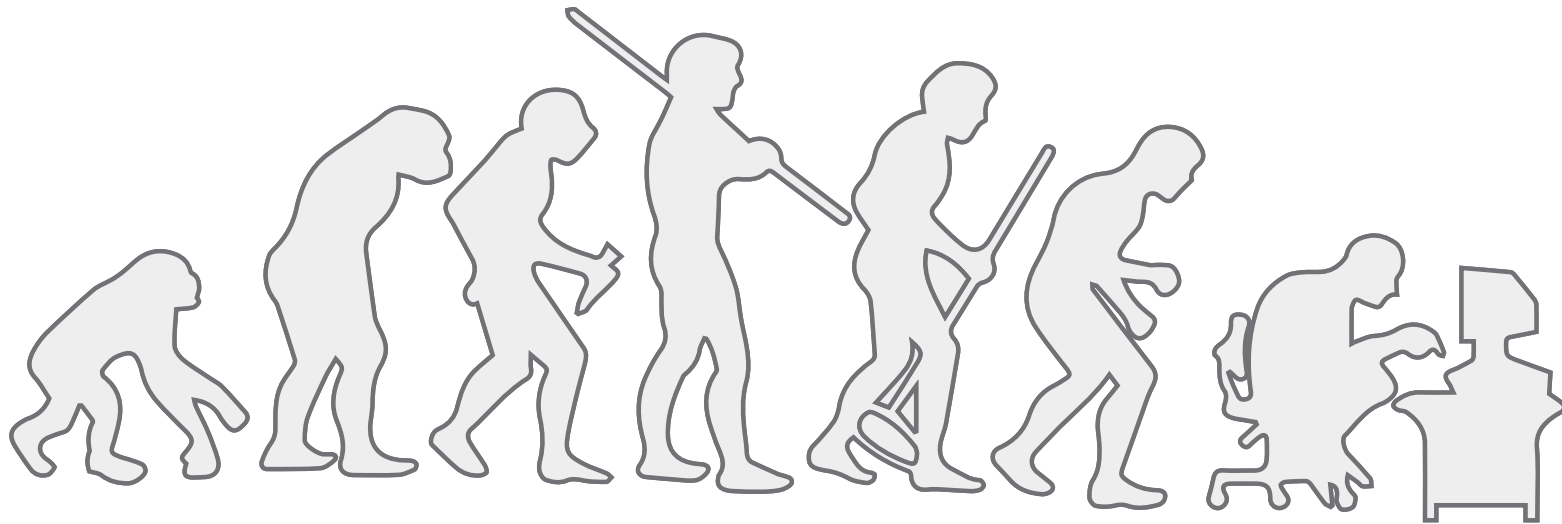

*Fig. 1: Something Went Wrong. Human evolution*



*Fig. 2: Hills.*



*Fig. 3: Lake.*



*Fig. 4: Forest.*

# Chapter 1: Introduction

## Problem Overview

The modern tech industry office building is figuratively the opposite of the forest hunting ground and farm field as far as workplaces are concerned. This thesis postulates that this need not be so. The modern human still operates with a mind and body that evolved when the workplace was entirely natural. The contemporary trend of isolating the workplace from nature causes many problems that are detrimental to worker wellness and productivity. These detriments manifest in ways that are social, psychological, and physiological. This thesis will prove that the ideal workplace is one that unifies nature and function.

As a large scale example, the city of Seattle stands as a marriage of nature and functionality that is pleasingly unobtrusive(Fig.5). Ironically, Seattle is the burgeoning hub of the global tech industry, whose workplaces suffer from an isolation from nature. Isolating the human from nature for the entire work day, 8.7hrs on average (Bureau of Labor Statistics, 2014)(Fig.6), it has been shown to cause stress and anxiety, as well as being a detriment to productivity (Lottrup Grahn, Stigsdotter, 2013). Isolating the worker from nature is a potentially fatal flaw for the tech industry, as it is

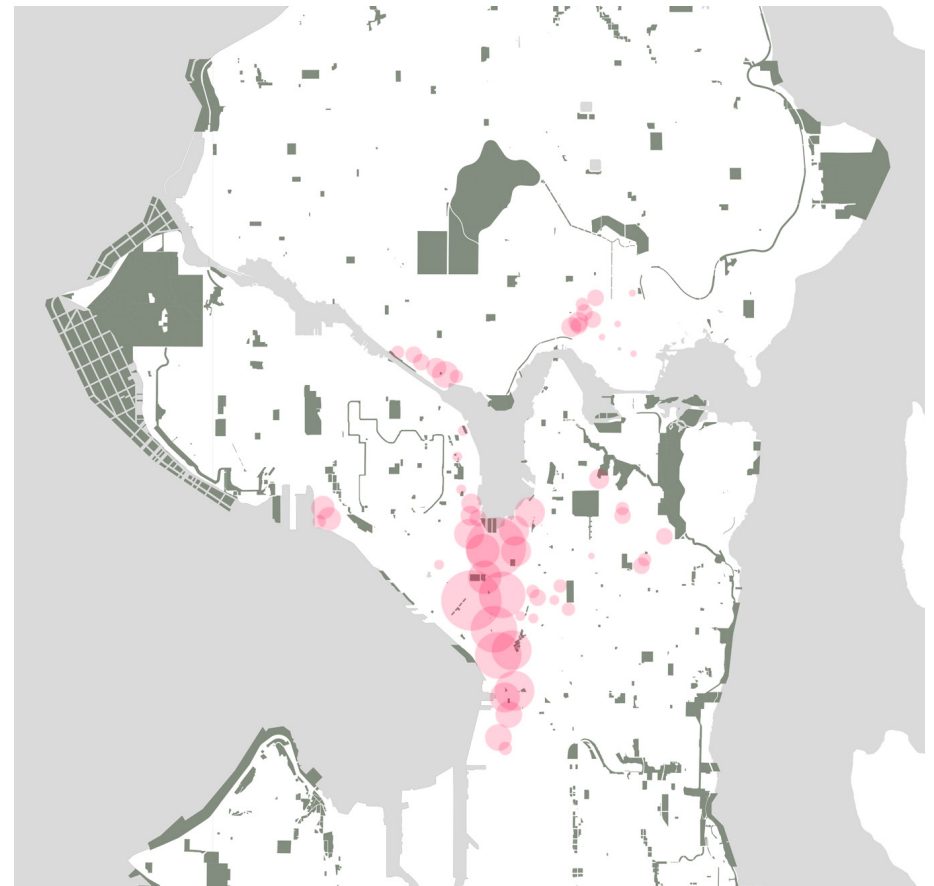

Green Space vs. Tech Office      ● Green Space      ● Tech Office

*Fig. 5: Seattle Green Space vs. Tech Office*

harmful to workers and businesses alike. This thesis will argue that existing workplaces should be upgraded by integrating nature through innovative architecture, which is in agreement with the theme of sustainability. Using the architectural theories elaborated in this thesis, the workplace will transcend functionality by reversing the detriments to worker social, physical, and psychological health to enhance general well being.

## **Project Rationale**

The tech industry will be the focus of this thesis because it generally trends toward environmental responsibility and sustainability. The tech industry is well known for rewarding innovation, if not requiring it. As such, changing the way office buildings are designed would have great appeal to a business in the tech industry; redefining office design has the potential to influence architecture theory across industries and to advance the reputation of the business that attempts it as being an iconoclast in employee relations and environmentally responsible design.

More than half of tech workers in traditional office spaces report dissatisfaction with their work environment (Fjeld, 1998). Numerous workers experience negative impact on well-being, such as stress, anxiety and loss of energy at work (Ostrovsky et al., 2009).

## Time use on an average work day for employed persons ages 25 to 54 with children

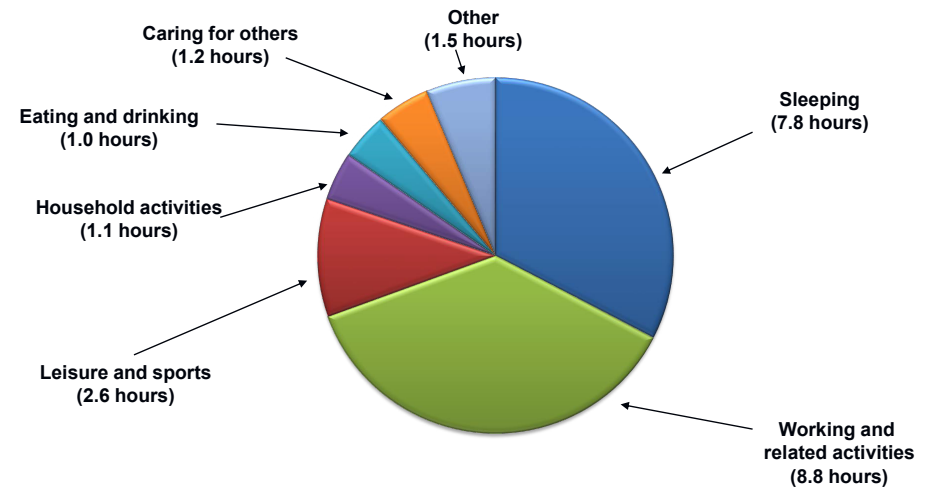

NOTE: Data include employed persons on days they worked, ages 25 to 54, who lived in households with children under 18. Data include non-holiday weekdays and are annual averages for 2015. Data include related travel for each activity.

SOURCE: Bureau of Labor Statistics, American Time Use Survey

*Fig. 6: American Time Use Survey*

## **Problem by Literature**

### **1. Lack of Access to Nature**

In the competition for advantageous real estate, many tech businesses resign to rent or buy office spaces in pre-existing buildings that are less than ideal for worker wellness. Many of these buildings are poorly designed, with compressed spatial qualities like stacked floor plates with low ceiling heights. Windows in these buildings are typically fixed glass, with minimal apertures that are not conducive to light penetration and air flow (Fig.7). Interiors are usually lit by florescent bulbs and framed by plain walls. Outdoor gardens and/or greenery spaces are uncommon in these concrete and steel buildings.

Studies have shown that working in environments like these can cause fatigue, depression, headaches (Ostrovsky et al., 2009), and many more physiological and psychological problems. These negative effects in turn impact productivity. Current trends for addressing these problems typically demonstrate as much effort as the addition of a break-room ping-pong table. This thesis argues that segregation from nature is a major contributing factor in these problems. The architectural improvements suggested here are deeper than interior cosmetics; they are elements of positively impactful spatial qualities.

### **2. Uncomfortable Building**

An uncomfortable building is arguably one that can result in absenteeism and even cause physical illness (Singh et al., 2010).



*Fig. 7: Portland Public Service Building*

Qualities like temperature, lighting, and air quality have physiological ramifications. Poor lighting, such as that provided by fluorescent bulbs, strain the eyes, and cause headaches and lethargy. Poor quality air, such as is found in air-tight buildings and/or buildings with inefficient HVAC systems, can aggravate workers' allergies, and can cause headaches and fatigue (Singh et al., 2010). Office temperature likely inspires workplace dissatisfaction as it is a product of a worker's lack of autonomy in the office, as well as a distraction. Despite the fact that the worker spends at least half of their waking day in the office, they have very little, if any, control to make it a comfortable and therefore conducive environment for productivity.

### 3. Poor Spatial Arrangement

Most of the first office workplaces were arranged around private personal offices, which were expensive to build and maintain, and inhibited employee collaboration. A subsequent trend was toward rows of over-exposed desks in expansive open floors, which proved distracting and too factory-like. Later came the advent of cubicles, the epitome of white collar drudgery (Fig.8). Cubicles of any height constrain the movement of workers, air, and light, and do not foster social interaction.

Contemporary office arrangement has revived open floor plans, in clusters instead of rows, without solving for the distraction factor(Fig.9). Tech companies tend to favor open plan office design. The open floor plan has the benefit of easing employee interaction, transparency, accountability, and collaboration, but occasionally at the expense of any work that requires more intense focus, and to the detriment of employees who work better individually. Many tech workers report being frustrated by open office plans, especially by distractions like passing foot traffic and unwanted noise from their coworkers (Stuart, 2015). In one survey, nearly half of workers in open offices said a lack of sound privacy was a significant problem, and more than 30% complained about a lack of visual privacy (Kim & de Dear, 2013). Despite its popularity, research shows that productivity loss doubled when offices were converted to an open-plan (Davis et al., 2011). The tech office is in need of an arrangement theory that benefits social well-being while balancing collaboration and privacy.



*Fig. 8: Office Cubicles*



*Fig. 9: Complementary Open-Plan Office*

## **Position Relative to the Literature**

According to the literature cited thus far, the modern tech industry office is flawed enough that businesses are negatively affected and tech workers and their productivity are suffering. This thesis will elaborate on the application of innovative concepts as a response to the aforementioned problems. Drawing on researches from different fields of studies, the ideas proposed in subsequent chapters is a unique approach to architecture and human health.

### Concepts in the Problem

The problems identified so far have three major dimensions; psychological, physical, and social well-being. The first concept suggests that lack of exposure to nature has negative psychological impact on well-being. Integrating nature into the building environment addresses this by applying established principles of biophilic design. Secondly, the concept of physical well-being in respect to comfort within a building environment. Physical health is affected positively by an environment that more resembles a healthy natural space. Using sustainable building strategy to inject nature into a building system to manipulate the inherent behaviors of key elements of nature will improve human comfort. Finally, the concept of social well-being as it relates to spatial arrangement. Social health benefits from a balance of personal space, privacy, and socialization. Applying concepts of self-controlled social interaction and functionality to workplace spatial arrangement using architecture as a response.

All three of these dimensions, psychological, physical, and social, are facets of human well-being and intersect with many other factors. This thesis will elaborate on responding to these problems using architectural design to integrate nature and utility to renovate most work spaces into an environment that facilitates the positive effects of natural elements on workplace well-being to benefit employees and businesses.

## **Overview of Thesis**

Modern office building design holds environmental responsibility and sustainability to be important. While commendable, this sustainable design continues to ignore the user experience and its negative impacts on workers. Tech office workspaces are frequently designed in a way that is detrimental to social, physiological, and psychological well-being. The main problem is a lack of access to nature and restrictive spatial arrangement, leading to an uncomfortable building. This thesis explores the problems and addressing them by making nature part of the building.

# Chapter 2

## Nature and Well-being

### Overview of Chapter

The primary goal of this design project is to provide a healthy workplace for tech workers. This will be approached from the following three main aspects; provide access to nature, proper spatial arrangement, and comfort in the built environment. All of these aspects are achieved by the underlaying of sustainable design features. The inclusion of nature could decrease stress, engage workers in physical activity, create spaces for social interaction, and improve building performance. This chapter will explore the benefit of nature to well-being, spatial arrangement for tech office, and comfort in the office. Ultimately, it will explain how it helps tech industry and its people's well-being.

### Defining Well-Being

Well-being results in a more enriched life experience. It is generally agreed to be at least a state of positive emotions and moods, general life satisfaction, sense of fulfillment, and positive functioning. Well-being is most simply described as feeling positive about oneself and one's life. Well-being encompasses many intersectional levels of individual health (Samhsa, 2016), as illustrated by the following diagram (Fig.10):

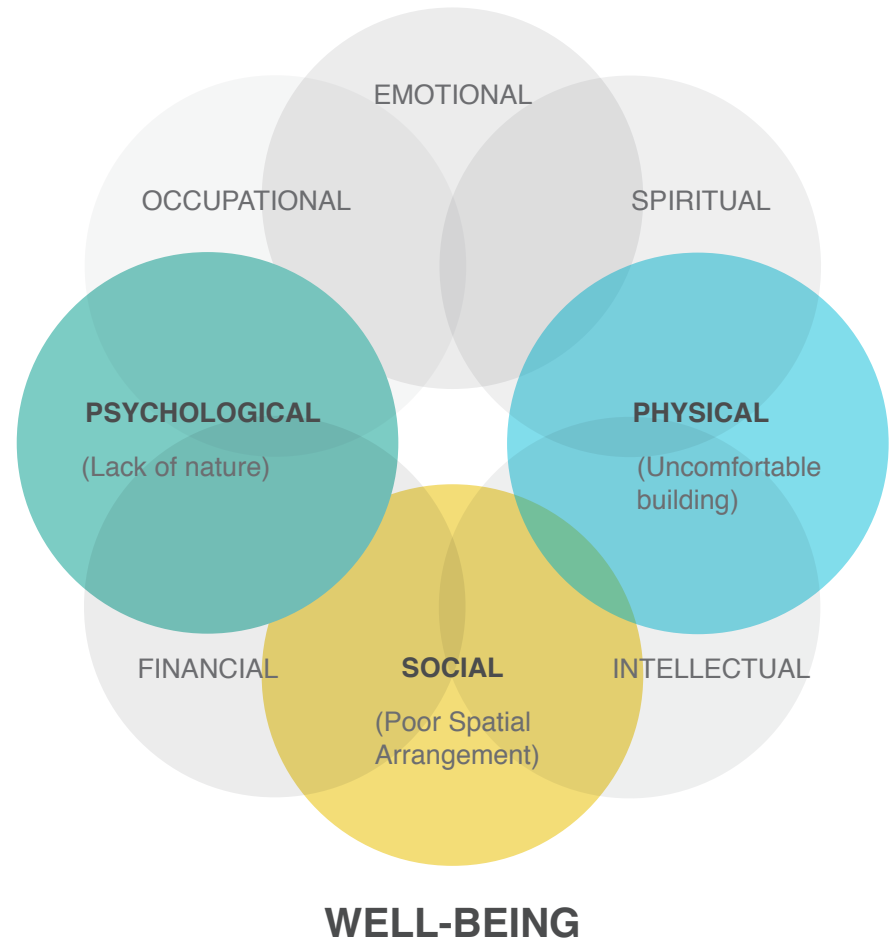

*Fig. 10: Eight Dimensions of Well-being*

Individual aspects of wellbeing are all interlinked with each other, such as mental health status is associated with physical activities, healthy eating, productivity, and social engagement. The presence of green space is proved to benefit the aspects mentioned above.

As of now, we cannot prove that architecture directly impacts every area of wellness. Studies have shown that the presence of natural elements can positively influence three of major aspects of wellness, however; social, physiological, and psychological (CDC, 2016). Workplace design will manipulate this influence to the benefit of workers and therefor businesses. For the purpose of this thesis, Emphasis has been placed on three facets of human well-being; social, physiological, and psychological.

For the purpose of this thesis these facets will be loosely defined as it applies to my work. Social wellness is one's comfort in socializing with other people, and it is best achieved by having individual control over how much social interaction one subjects themselves to. Workspace design should enable workers to choose an environment that suits their social wellness best, but encourages them to collaborate. In the workplace, a worker with good physiological well-being is productive and happy to go to work, as they have a positive level of happiness and a generally unstressed mental state. Physical well-being is bodily health, so it is influenced by an employee's life choices. In the workplace however, actions for improving physical health are limited as the worker is quite sedentary,

negatively impacting physical wellness. Good nutrition, physical exercise, exposure to fresh air, and thermal comfort are the most feasible elements of physical well-being in the workplace. The office building designs explored in this thesis focus on these three facets of human well-being and how they can be improved by architecture design.

## **Importance of Worker Well-Being**

People spend approximately a third of their waking weekdays in their place of employment, so it is in their employer's interest to assure that people do not suffer while working. "An estimated 7% of employer health-related costs can be attributed to absenteeism.... [addressing] the wellness-focused aspects of the workplace is an opportunity to reduce these costs." Employees are more likely to choose to be absent from work if their workplaces are dissatisfying, especially in regards to air quality, noise, and light (Gensler, 2013). This absenteeism is measurable, totaling an estimated \$225.8 billion annually in the US according to the CDC (CDC, 2016).

"'Sense of place' is a widely-used term, and one that remains difficult to define. ... [The] term connotes the atmosphere of a place, the quality of its environment. This matters because 'we recognize that certain localities have an attraction which gives us a certain indefinable sense of well-being and which we want to return to, time and again.'" (Frumkin, 2003). The office is a place to work, but its presence, the workers' sense of the place, can negatively affect their

well-being. In workplace design, spatial layout, nature contact, and building comfort can provide numerous benefits to psychological, physiological, and social wellness. The methods explored in this paper will do this, and in doing so will save businesses money cost by absenteeism and improved employee productivity.

## **Relationship of Nature and Well-Being**

The concepts explored in this thesis should not be confused with LEED principles (see the US Green Building Council's website for more information on LEED). The research that inspires a lot of my methods is called Biophilic Design. LEED buildings are designed primarily for to the goal environmental responsibility and sustainability, but lack established considerations for benefiting humans otherwise. LEED principles are a great innovation for environmental health, but this proposal takes the ideas of nature and health further.

## **Nature and Well-Being**

Henry David Thoreau said "Nature is but another name for health, and the seasons are but different states of health." Biophilia is the scientific term for the connection of nature and human health. As mentioned earlier, the worker is inclined to be most productive in spaces resembling the first human workplaces. "The evolutionary context for the development of the human mind and body was a mainly sensory world dominated by critical environmental features such as light, sound, odor, wind, weather, water, vegetation, animals,

and landscapes. The deliberate attempt to translate an understanding of the inherent human affinity to affiliate with natural system and processes into the design of the built environment is called biophilic design." (Kellert et al., 2008). This evolutionary context manifests in a human affinity for nature. Biophilic Design applies this to architectural functions.

There are two basic dimensions of Biophilic Design; organic or naturalistic, and locational or vernacular. The organic dimension is defined as forms in the environment that arouse the innate human affinity for nature, and it is further defined by symbolic, direct, and indirect experiences. Symbolic or vicarious experience involves instead the representation of the natural world via images, photos, metaphors, replicas, and the like. The vernacular dimension is defined by how buildings and landscapes connect to the culture and ecology of their geographic location. This dimension concerns a sense of place as being integral to individual and collective identities (Kellert et al., 2008). Metaphorically, it concerns a physical place as a character within the story of life. Direct experience is focused on unstructured contact with features of Earth, such as sunlight, plants, animals, and natural fresh air. Indirect experience is based around human stewardship as a necessity, for example the maintenance of an aquarium or potted plant (Kellert, et al., 2008).

## Biophilia in the Workplace

Research from various fields of science has produced results that can be applied to workplace design and employee well-being. It has been established that the human brain responds functionally to sensory patterns and cues originating from the natural environment. Furthermore, contact with nature has shown a positive correlation to cognitive function in concentration and memory (Kellert et al., 2008). This shows that contact with nature provides opportunities to improve intellectual functioning for workers in tech offices. Offices that incorporate Biophilic Design, such as natural lighting, natural ventilation, plant life, and other natural features, experience improved employee productivity, and have workers with greater motivation and lower stress. Exposure to nature can improve physical, psychological, and social well-being, whether from a view of nature through a window or exercising in a green space (Barton & Pretty, 2010). Interestingly, one study found that workers reported reduced discomfort up to 23% and reduced fatigue up to 37% when their offices introduced potted plants (Fjeld, 1998).

## Biophilia in the Community

An office building that applies Biophilic Design can positively affect social well-being at two levels of community; the intra-employee community and the urban/residential community around it. Built environments that provide a positive “sense of place” frequently inspire a sense of stewardship in people. On the scale of

a community, this manifests in greater “neighborliness,” a greater valuing of nature, and a better quality of life (Kellert et al., 2008). If people enjoy the community they live in, they are more inclined to take care of it. A site that both incorporates a Biophilic Design and opens some elements of the campus or building to the public belongs to a company that practices strong social responsibility by providing a protected nature space for its community.



*Fig. 11: Pasona Headquarters Facade*

## Case Study: Pasona Headquarters

An example of a building that applies Biophilic Designs to its plans successfully to great result is the Pasona Headquarters located in downtown Tokyo, Japan. The 50-year-old building was renovated to integrate agriculture and nature. At its completion in 2010, the renovations included a double skinned green façade, a rooftop garden, and its famous garden pots scattered around the offices, from which employees harvest “zero-mileage” produce for their own meals (Architizer, 2011) (Fig.11-13). Pasona Headquarters is now a local icon as a stunningly innovative building wherein office workers and crops share a common space. Employees of Pasona HQ report being happier and more productive. Furthermore, through its reputation and visibility, the building itself promotes public awareness of sustainability and workplace well-being.



Fig. 12: Pasona Headquarters Interior

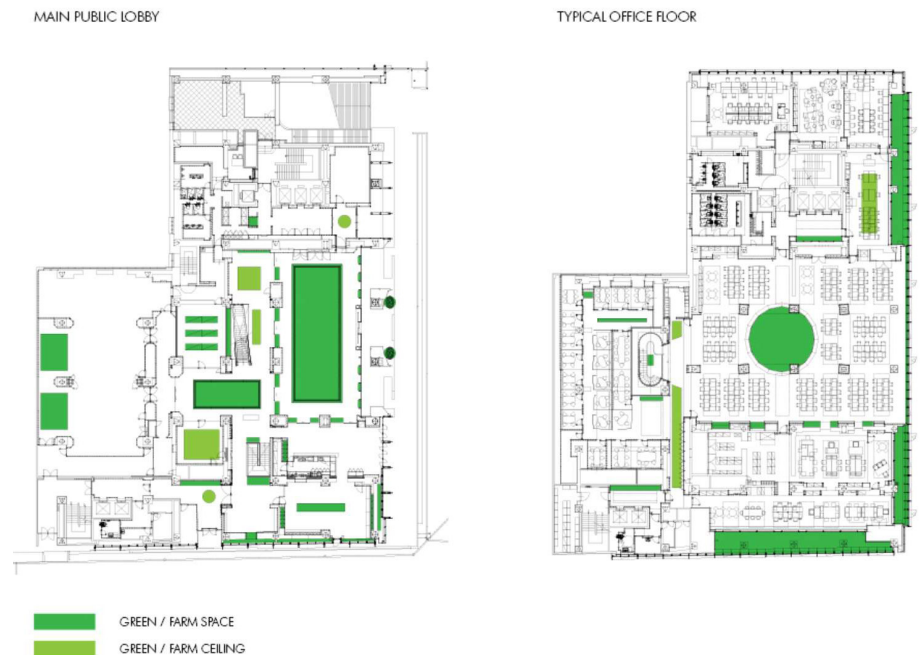

Fig. 13: Pasona Headquarters Plans

## **Spatial Arrangement and Well-Being**

Moments of privacy are scarce in the modern workplace, as most offices use open floor plans or other plans designed primarily for collaborative work. This negatively impacts social and physiological well-being by negatively impacting stress levels, social interactions, and productivity.

An ideal office space is designed to keep workers happy, so it has a balance of work areas designed for focus work and collaborative work. Most people fluctuate between introvert and extrovert tendencies, just as work tasks may fluctuate between a nature requiring individual focus or group input. Furthermore, in order to bring their best thinking to a collaborative task, employees benefit from occasional private time for concentration (Steelcase, 2016). Every office should have a balance of areas for work requiring focus and work of a collaborative nature that all employees have an equal access to, where they can choose the one that suits their work and well-being best.

## **Activity and Well-Being**

Many aspects of building design neglect the fact that work spaces have direct impacts on physical health. Physical fitness of employees suffers from the sedentary nature of working at a desk for hours, as staying in any one position for an extended period has many negative physical impacts. This can lead to an increase in obese and frequently ill employees; more absenteeism (ODPHP, 2008).

The US Physical Activity Guideline recommends adults have at least 150 minutes of moderate physical activity per week. This guideline specifically recommends general gardening, walking, and bicycling as ideal moderate-intensity activities (ODPHP, 2008).

When activity happens in a natural setting, it provides benefits on multiple levels of well-being. This has been dubbed “green exercise” and is simply defined as physical activity that takes place in a natural environment. Research has shown that green exercise fosters social bonds between participants, improves both self-esteem and mood, influences behavioral choices, improves cognitive retention, and increases one’s valuation of nature (Barton & Petty, 2010). Workplaces can take advantage of the benefits of green exercise by allowing employees frequent access to nature. Providing green spaces for employees to satisfy these basic physical activity suggestions is a simple way to improve workers’ physical and social well-being.

## **Building Comfort and Well-Being**

Though physical comfort is highly subjective, some factors of human bodily comfort are generally objective. A comfortable building has good air quality, mild humidity, temperature level (68-78 degrees Fahrenheit depending on season [Burroughs & Hansen, 2011, p. 63]), lighting intensity, minimal odors, a lack of low-level contaminants, and noise separation (Miller and Davis, 2009). Good quality space should satisfy workers’ basic comfort needs. Contemporary building designs

ignore user's well-being and comfort. Sustainable engineering and architectural design are important strategies, but they do not go far enough.

## Case Study: Bullitt Center

The Bullitt Center in the Capitol Hill neighborhood of Seattle is an example of a building that seeks high levels of environmental stewardship while delivering a comfortable user experience (Fig.14). Among the sustainable strategies demonstrated in the six-story commercial building are a solar panel rooftop, site-wide rainwater collection and treatment. It is heated by a ground-source heat



Fig. 14: Bullitt Center Exterior

exchange system of 26, 400-foot-deep wells. The structure is made from sustainable, locally-harvested timber (Fig.15). All materials in the building are compliant with the materials “red list” that excludes chemicals that are harmful to people and the planet. Its many viewing windows feature automatic external window blinds (Bullitt Center, 2017) (Fig.16). The Bullitt Center is a good reference for future office buildings to adopt the high-performance technologies as it demonstrates that performance-based design has its place in a market-rate commercial project. Some ways they achieve worker comfort is by installing user-controlled operable windows that workers can open according to their temperature needs, as well as



Fig. 15: Bullitt Center Interior

external solar-triggered blinds that reduce glare and heat by diffusing direct sunlight. The Bullitt Center is in this way an example of how environmental sustainability and worker comfort can be achieved simultaneously.

## **Urban Cultivation**

Urban cultivation provides a connection to nature for city dwellers and urban space. Its benefits are greater than public parks but less sizeable than agriculture. Urban cultivation should not be confused with urban farming, which has the goal of growing food in high density urban areas. The objective of urban cultivation is to achieve building integrated agriculture with the ultimate goal of improving the wellbeing of employees, communities, and businesses (Martin, Clift, Christie, 2016). Greenscape walkways and farming in the office provides the opportunity for short engagement of green exercise for the benefit of human well-being. This thesis proposes that using urban cultivation in architecture design is a potential solution to the problems and shortcomings of the modern office workspace. Urban cultivation is a kind of Biophilic design in an architectural context.

## **Conclusion**

Multiple studies have established the detrimental impacts of buildings designed to typical sustainability standards do not adequately address employee well-being. Restrictive space planning has a detrimental impact on workers and their productivity, as does



*Fig. 16: Bullitt Center Facade Treatment*

working in an uncomfortable environment. A collection of research suggests that nature should be incorporated into workplace design. The benefits nature and natural elements provide to human wellness and productivity makes Biophilic design a largely untapped resource for the improvement of workers, businesses, and communities. Urban cultivation is a clear opportunity to incorporate the resources of nature into building design.

# Chapter 3

## Cultivating Well-being

### Overview of the Design Method

Green building standards such as LEED have not adequately addressed the health and well-being of people in modern workspaces. This thesis proposes that LEED principles can be strengthened by encouraging the adoption of urban cultivation design. Urban cultivation design is capable of achieving this effect both simultaneously and sustainably. Urban cultivation improves on the concepts Building Integrated Agriculture in that the green spaces it creates and utilizes are not restricted to the building itself, but also incorporates surrounding land features (Gould & Caplow, 2012).

Recent studies in workplace efficiency and employee conditions have established that biophilia benefits workers and their productivity. However, LEED only addresses environmental and ecological impacts in architecture. Urban cultivation would improve upon those principles to benefit the worker, not just the workplace.

Urban cultivation takes advantage of the many benefits of biophilia by integrating nature into a structure. Previous chapters have established that contemporary workplace and office architectural design neglects the three major areas of human well being; physical, social, and psychological health. Integrating urban cultivation into

building architecture will alleviate these weaknesses by weaving workspace and nature together.

Physical health will receive the immediate benefits from the most natural and essential elements of urban cultivation; the plant life. Plants will purify indoor air and contribute to thermal comfort by adjusting temperatures. Furthermore, research has shown that the presence of plant life improves human health immediately by lowering blood pressure, in addition to enhancing self-esteem and mood by through green exercise (Barton & Pretty, 2010). Urban cultivation employs these benefits by providing the space and opportunity for short engagement of green exercise. Long-term benefits of urban cultivation include the production of fresh produce. This produce may be nurtured, harvested, and consumed by the employee, who in turn will receive benefits from the presence, cultivation, and consumption of these plants; from seed to plate.

Biophilia, as established previously, describes the benefits to human psychological health from proximity to natural elements such as moving water, natural sunlight, vista, fresh air, and plant life. By integrating nature into the workspace to create a building occupants will experience improved productivity and reduced anxiety.

The workplace is a highly social environment, which, as mentioned in Chapter 2, is often too social. Urban cultivation will manipulate floor plans and green space to reduce the social aspect of the personal workspace, i.e. cubicle, while concentrating that social energy into designated social areas. Personal workspaces

will be separated with architectural features like light wells, vertical farming partitions, and planting spaces. Office break rooms will be green spaces or green space adjacent. This compartmentalization will improve productivity by allowing focus in the workspace without creating workplace isolation. Furthermore, the social impact of the workplace will expand into the local community. Outdoor green space and rooftop space should be converted into garden spaces, with priority assignment to volunteer employees. The local community may be invited to participate as well. This will create an integral relationship with the local population. This public engagement benefits the business by establishing it as an element of the community. A community that is invested in a local business will often protect it, i.e. in matters of local government. A community's investment fosters a sense of stewardship in return for the benefits the business provides.

## **Goals and Objectives**

The tech industry, now occupies a major role in the economy and employs a sizable sector of modern office workers. Yet the contemporary tech office does not address worker well-being: it lacks a connection to nature, is often poorly lit by electric lights, lacks fresh air, and has an indoor environment controlled by expensive, energy intensive machinery. The objective of urban cultivation is to address these flaws and create a more productive and pleasant work environment.

One goal of urban cultivation is to provide psychological benefits by incorporating natural elements into the work space. This kind of work space is one that is healthy and that encourages creativity and reduces stress. This can be achieved by exposing the space to natural daylight, views of water and the landscape, adding green-life, and other elements of biophilia. An additional goal is to promote physical health by enabling physical activity and exercise, as well as supplementing workers' diets with nutritional produce. Providing high quality air is also part of ensuring physical well being, by using the natural properties of plants to filter air and regulate temperatures, creating a sustainable and invigorating work space. Another goal is the effective regulation and improvement of social interactions on two levels; interactions between workers within the company, and between the company and the community it calls home. Internal social improvement is to be achieved by creating designated group work spaces (meeting rooms, conference rooms, etc.) into rooms that could be considered working gardens. On the inter-community level, this is to be achieved by constructing a community

garden in place of a courtyard and by incorporating a vertical garden into the building facade. This highly visible approach to gardening will advertise the business's dedication to ecological sustainability and community welfare. Another goal of urban cultivation is to boost productivity, and that is achieved concurrently with the achievement of the aforementioned goals. The final goal of urban cultivation is the improvement of building performance by taking advantage of naturally occurring resources to reduce costs and negative ecological impact. This is achieved with the incorporation of architectural features such as garden facades, operable windows, excessive natural daylight, and sustainable ventilation strategies.

The goal of my proposal is to implement nature into architecture to cultivate well-being. Complete application of my design has the potential to cultivate well-being of the employee and so benefits the business, and even further, benefits the business's local civilian community. This proposal also builds upon established principles of spatial arrangement and adaptive renovation. In the spirit of being environmentally sustainable and cost effective, my proposal is about upgrading existing structures (Fig.17).



Fig. 17: Three Dimensions of Workplace Well-being

## Site Analysis

Stewart Brand, an environmental scientist, defined a building's suitability for upgrade as its "potential to learn." Brand's diagram, shown here, describes how a building can "learn," or how its space plan and envelope can be transformed, as long as its site and structure can retain their integrity (Brand, 1994) (Fig. 18). Using this strategy, we can identify a building that has the most potential to adopt Urban Cultivation. First and foremost, qualifying structures must have the structural integrity to support additional weight (soil, water, plants, etc.). This narrows down qualified buildings to more recent constructions. The building's envelope must have the potential to be reduced to a selectively discriminate barrier to the site. The ideal location is close to nature while still being located advantageously within urban infrastructure. A perfect site has been constructed with its environment in mind; designed to fit well in context with its environment.

This thesis will demonstrate the maximum effective integration of urban cultivation by using an ideal site as a hypothetical example. The selection of such a site starts wide, and then narrows. For this choice, a commercial location already populated by similar tech companies was important. The influence of urban cultivation on the company's reputation should receive maximum exposure to its peers in order to be more influential within the tech industry. Next, the infrastructure surrounding the site should be within sightline of natural vistas, not isolated from residential and commercial zones, accessible

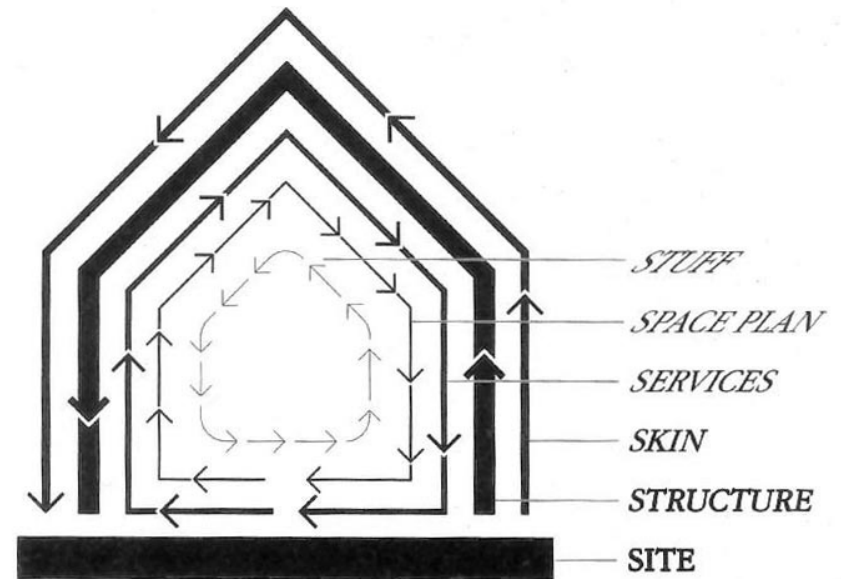

Fig. 18: Building Layers Diagram

to employees, and visible enough to become a landmark. The neighborhood of Fremont meets all of these qualifications. Further narrowing of choices is achieved by judging adjacency to nature, while still being surrounded to tech industry peers. The waterfront properties along Lake Union were the most ideal. They are relatively new constructions likely to have the structural integrity to support urban cultivation while possessing panoramic views of the lake and groves of trees while still being enviably close to arterial roads. There are eight buildings in this cluster that are suitable. Of these buildings, the Fremont Lake Union Center was the most visible and best situated (Fig.19).

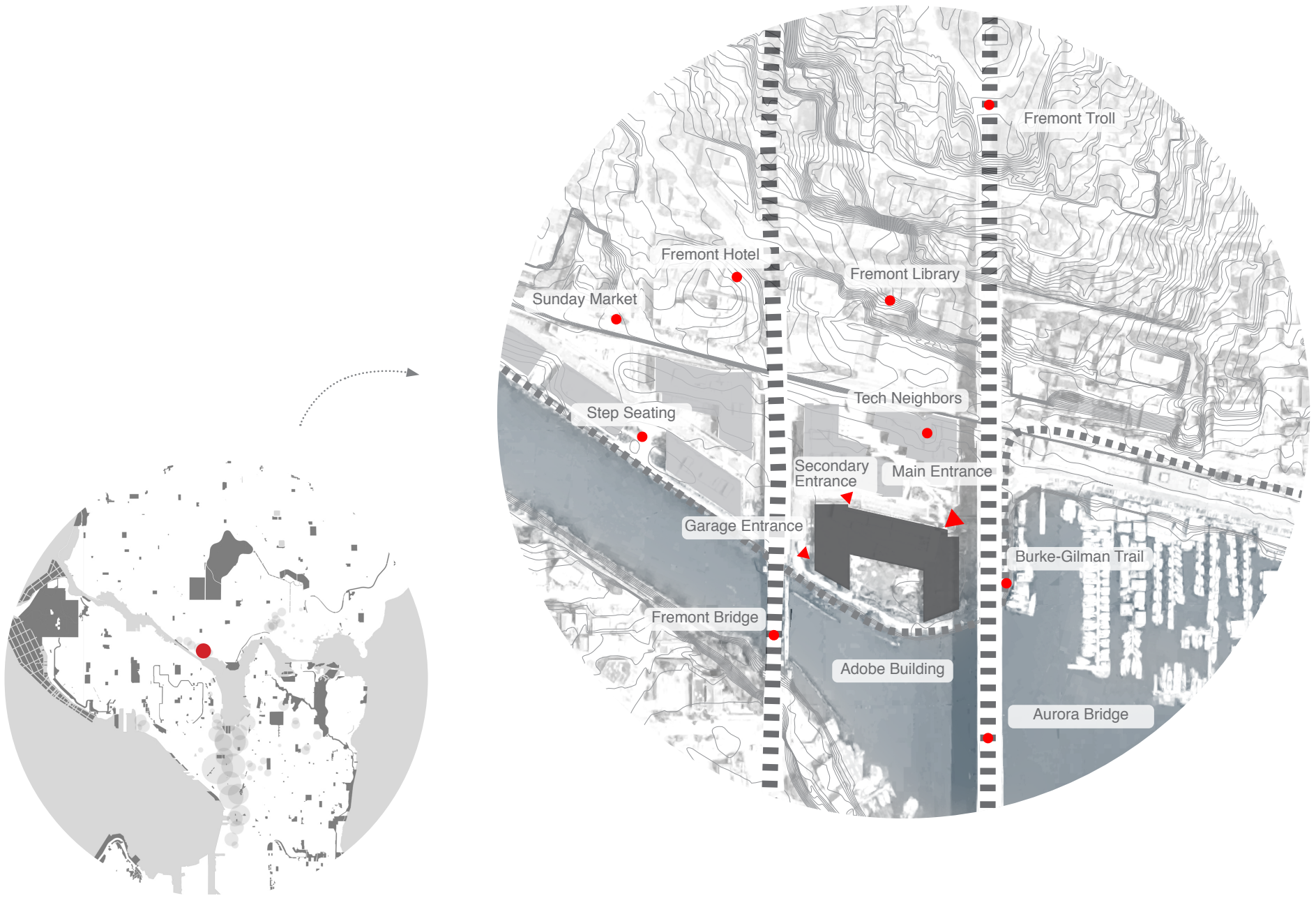

Fig. 19: Site Context Map

An example of a building with the most potential to achieve the maximum benefits of urban culture design is located in the Fremont neighborhood of Seattle; the building known as the Fremont Lake Union Center, located at 801 N. 34th St, Seattle (Fig.20). The Fremont Lake Union Center is a concrete structure built in 1998 by NBBJ. It is a LEED certified office building with a 500 employee capacity. Each of its three stories have a typical floor area of 54,666 square feet, and the rentable area totals 164, 961 square feet. The structure has the capacity to bear the additional weight of soil, plants,

water, etc. required to incorporate urban cultivation. The building is U-shaped, with each of its branches parallel to the two bridges it is situated between. One of these bridges is arterial and higher elevated, while the other is a local landmark with frequent pedestrian and vehicle traffic. These bridges have unobstructed views of the building's rooftop spaces. Between the branches of the building is a generously oversized courtyard that faces directly to Lake Union, separated from the shore by only a public trail. Behind it is a set of twin office buildings cut through with a pedestrian path. The building



*Fig. 20: Site Aerial View*

has an ideal orientation towards nature and a robust structure with the potential to learn. Such natural beauty is a resource that should be welcomed into the structure for the happiness of workers and the cultivation of well-being(Fig.21-24). However, this Adobe building falls short of its full potential. Despite its adjacency to nature and big open spaces, the structure lacks a solid connection to its context. Its envelope almost creates an indiscriminate barrier from nature and its neighborhood, exemplified by its isolating courtyard (Fig.25,26). As a result, its interior has poor spatial quality that negatively impacts workers(Fig.27,28). My design proposes to strip away most of the building down to its floor plates and structural bones.



*Fig. 24: Aurora Bridge*



*Fig. 21: Burke Gilman Trail*



*Fig. 22: Fremont Cut*



*Fig. 23: Fremont Bridge*

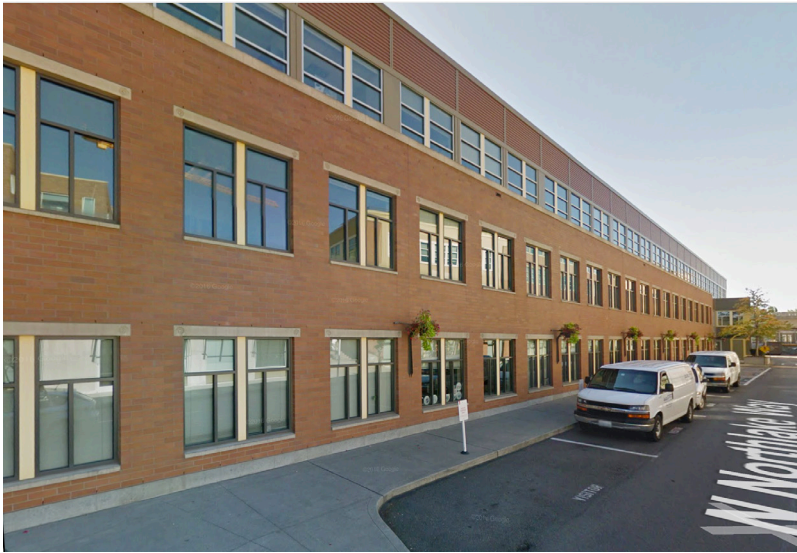

*Fig. 25: Site Existing North Facade*



*Fig. 26: Site Existing West Facade*



*Fig. 27: Adobe Building Interior Cubicles*



*Fig. 28: Adobe Building Interior Hallway*

## **Design Approach**

The hypothetical finished project will demonstrate principles of biophilic design and urban cultivation aimed at community health and worker well-being. It will incorporate nature so thoroughly, that it may be considered a refurbished greenhouse, a working garden, or a living office. Penetrating the building to expose it to nature. Taking advantage of the entire property to expand the office space into the outdoor space by enhancing its inherent features. As this requires removing existing square footage to allow better connection to light, air and nature, a “net-zero space” strategy will be applied so that the renewed building has as much or more “real estate” as the existing building. For every existing square foot removed from typical use, a new square foot will be created on or within the existing structure. This is done by adding a level and incorporating the rooftop space, as well as strategic manipulation of surface levels.

## **Program**

The function of the space is still primarily an office building. In addition to traditional office building amenities and necessary supporting elements, the ideal living office that has fully integrated urban cultivation also contains a public restaurant, visible food storage, community garden, a market space, rooftop greenhouses, and other minor features. The restaurant will be open to neighboring tech companies’ employees, so as to further establish the company as an iconoclast in employee wellbeing and technological innovation.

The kitchen’s pantry will be highly visible so as to showcase year-round produce yields. The community garden will replace the existing courtyard space, situated so as to welcome the community into an environment of learning and innovation. A unique produce marketplace will encourage not only traditional business, but also trading and selling of community members’ home grown produce. The rooftop will be converted to garden spaces and greenhouses designed for year-round produce. This living office building will entangle itself with its community like no contemporary commercial office building could make possible.

## **Limits and Delimits**

The new ideas and methods I will introduce in this thesis are currently untested, as they will be applied only hypothetically, as explored in the next chapter. These ideas are inspired and supported by research conducted across multiple fields of study, including psychology, botany, physiology, etc. Other support for my theories comes from case studies of existing architecture projects of a similar nature to what I propose.

This project makes no attempt to address a problem of food supply or food deserts. The choice to use the production of food as a benefit is that it makes edible plants a better option to grow in green spaces as opposed to purely decorative plants. The suggestion of selling and/or serving this produce is not to suggest a required level of production. The benefits of using edible plants are not reduced by the

size of harvests.

Though only three points of human well-being are considered in this paper, they are not excluded from being positively affected. As this is an untested experiment, it is uncertain the extent of what those effects could be. Attempting to make claims about them could not be supported by research and so they were excluded for that reason alone.

While this thesis focuses on retrofitting an existing structure, there is nothing suggested by the literature that implies that these methods cannot be applied to new constructions. Furthermore, this thesis focuses exclusively on buildings occupied by the tech industry only as that industry is most likely to include potentially interested clients. Suggestions of this project affecting world-wide architectural theory and business renown would also be unsupportable and full of hubris, so they have been nonexistent here.

# Chapter 4

## Design Proposal

### Site Design

As it stands today, the Fremont Lake Union Center has its back turned to its neighborhood. Despite its prime location, it fails to fully realize its potential to connect with its context.

The first step in connecting this site to its context requires opening the structure, especially the ground floor. The massing of the ground floor needs penetrated to allow more public access and exposure. The structure should be cleaved into three independent buildings and reconnected by sky bridges. The edges of the structure will be softened to the newly open spaces between the buildings to imbue them with their own identities. As the site is located between N. Northlake Way and the popular Burke Gilman Trail, the structure can take full advantage of its context by creating, and becoming, a connection to the two. Behind the structure, across N. Northlake Way, the neighboring tech building has its own pedestrian plaza connecting the N. Northlake Way diagonally through the block to 34th Street. Opening the Fremont Lake Union Center can complete this pathway towards the Burke Gilman Trail. Such a connection will further integrate the structure into its context, both Fremont and its tech neighbors.

Relocating the employee and public entrances will change the organization of the building's and enrich its potential for new functions. The employee entrance, between the west wing and the central building, will be a secure but welcoming atrium. Key card access and/or security guards will be visible but not imposing. The public entrance will be within the Community Passage created between the east wing and the central building. This redesign in access will change the circulation that is informed by the joints that are the sky bridges.

The next step in design is to penetrate and carve into the floor plan to inject nature into the structure. This includes the addition of light wells, sky lights, balconies, planters and garden spaces, interior courtyards, and patios. These additions make the structure permeable to nature, allowing natural elements to penetrate the buildings as well as hosting some nature within.

Some spaces on multiple levels throughout the building will be carved away. On the ground floor, this will allow the structure to fully engage the landscape; especially through sheltered outdoor spaces and circulation of movement. On upper floors, it will enhance the flow of fresh air and the penetration of natural sunlight. New spaces will be created throughout the structure this way, using the principles of Net Zero design. Any space removed from the floor plan will be reclaimed from previously unused spaces elsewhere in, or on, the structure(Fig.29).

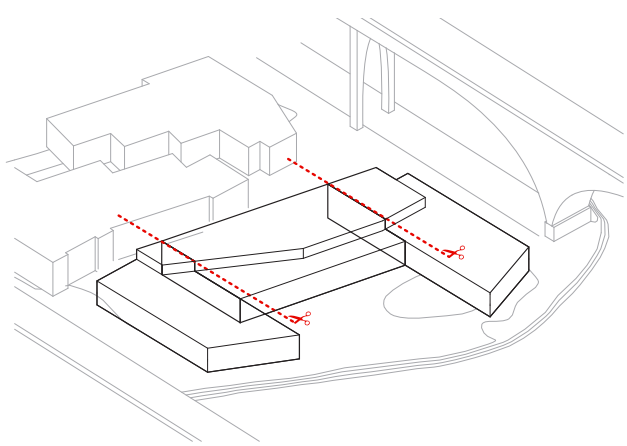

1.Divison

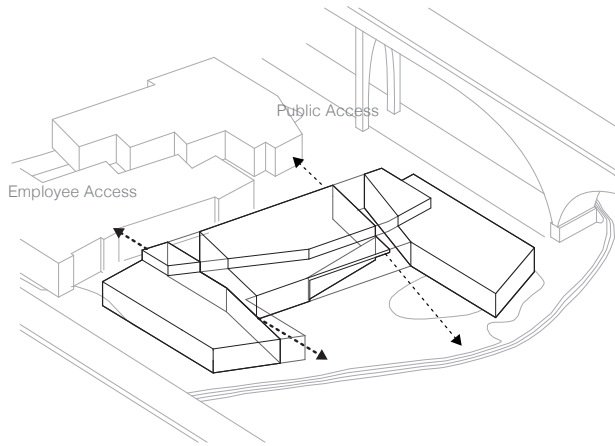

2.Relocate Entrances

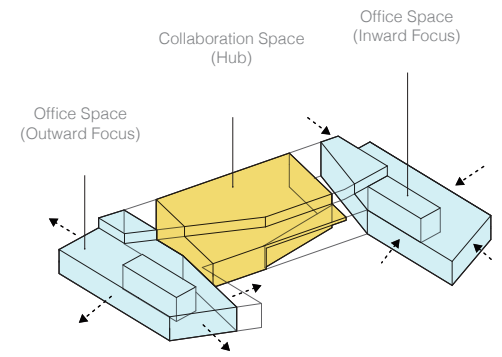

3.Massing Feature

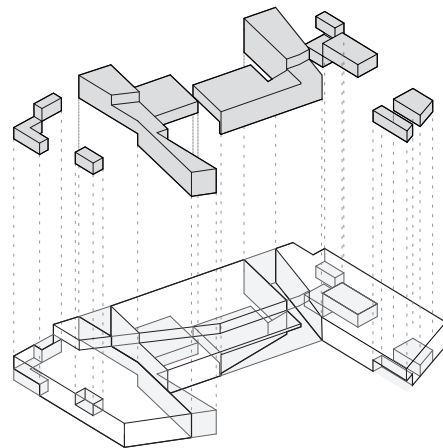

4.Removal

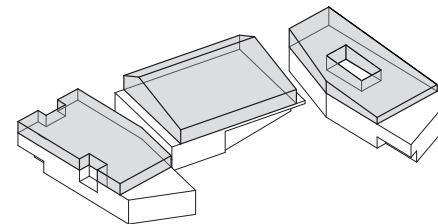

5.Renewal

Fig. 29: Concept Diagram

## **Massing**

The central building will include the greenhouse, a restaurant, produce market, and cafe, as well as spaces for education and collaboration. A corner wedge will be cut out of the central building where it is closest to the east wing, while keeping the existing roof and structural beams. This removal of floor plate and wall creates a patio space. This serves to soften the space and further inform the circulation of movement. Construction of a greenhouse to crown the central building both keeps with Net Zero design and creates valuable, productive green space.

The newly severed east and west wings will function primarily as office work spaces. Both wings will have their own unique character, specifically to the green space arrangement strategy used in each.

The east wing is designed to be internally focused in regards to its green spaces. This means that the green spaces of the east wing will largely be interior features. The center of the building will be opened with staggered light wells, which are conducive to ventilation and natural light penetration. east wing floor plans will be punctuated with interior green spaces and gardens. Net Zero design manifests itself in the east wing's design by the creation of a rooftop garden. This garden landscape is an outdoor work space that is conducive to both focus work and collaboration. It is a permeable landscape feature on a gently sloping plane to facilitate the collection and storage of rainwater for future on-site use. Additionally, the slope will decline

towards the south, creating an amphitheater-like view of Lake Union and downtown Seattle.

The west wing is designed with an outward focus about its Biophilic features. In contrast to the east wing, the majority of gardens in the west wing will be on its exterior. As done to the central building, a wedge of the west wing will be cut away and repurposed into patio and balcony spaces, further softening the building mass and influencing circulation. Its walls open to the outside in onto balconies and patios, heretofore referred to as sun gardens. Net Zero design is seen by the addition of a floor dedicated to office work spaces. The new floor will share former roof space with an open rooftop patio. The roof of the new floor is allocated to photovoltaic panels for the collection of solar energy for on-site use.

## **Remodeling of the Skin**

The existing exterior walls act as indiscriminate barrier to the site's context. The existing envelope should be replaced with sustainable alternative materials. Where advantageous, energy-efficient curtain wall systems will be installed. Supplementing these curtain walls will be operable windows and doors. In addition to having a larger aperture for natural light and fresh air flow, the clean and modern aesthetics of largely-glass walls gives the structure a refreshed appearance.

Implementing a selectively permeable skin transforms the structure into a Mixed Mode building. Such buildings can close

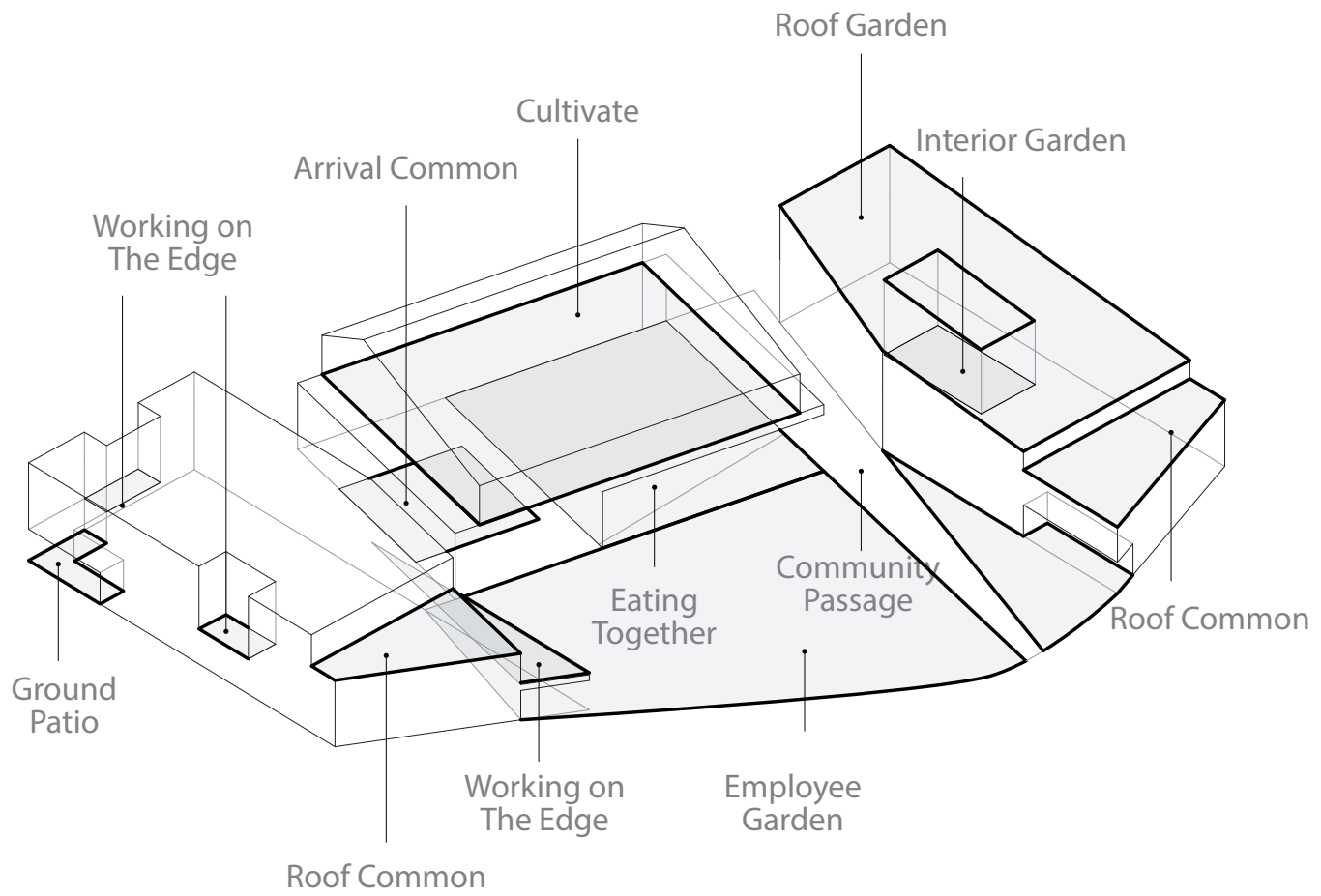

Fig. 30: Cultivation Features

completely and open for natural ventilation, differentiated as closed mode and opened mode (Brager & Baker, 2008). The operable windows and doors of the curtain wall systems on the Fremont Lake Union Center are the switches, or systems of opening and closing, that make it a Mixed-Mode building.

Automatic exterior blinds will complement the curtain walls. These will serve to save energy on temperature control by reducing heat gain from excessive sunlight. Exterior blinds also improve the workspace by reducing glare and diffusing direct sunlight, to the benefit of employees. Some northern facades (because they lack sun exposure) will have fewer windows and thus act as thermal barriers by serving to keep thermal energy within the building. On their interior, these solid walls will provide the privacy and/or usable wall surface for service spaces like bathrooms and mechanical closets.

## **Spatial Arrangement**

Urban Cultivation principles will be applied to the work spaces of both the west and east wings, with consideration for their identities. The key concept of design will be the division of collaboration zones, focus zones, and transition spaces. Because the benefits of each zone is dependent on the individual employee and their current task, it is integral that this office reject assigned seating. This allows workers to choose the workspace that would suit them, and their work, the most. For example, for one task, an employee may find it best to work alone somewhere conducive to deeper focus, but for a different task

an employee may benefit from collaboration with their peers or from seeking external inspiration. Additionally, this increase in autonomy improves workplace satisfaction, psychological well-being, and worker productivity (Lapierre & Giroux, 2003), as detailed in Chapter 2.

Taking advantage of the arrangement of inward and outward nature focus to different strengths in both wings gives all employees equal access to nature and the spaces that most benefit their productivity. The variety of green space configuration is an incentive for employees to move about the entire structure and to discover their most productive workspace.

Employee relations will be further enhanced by this equal access, as increased chance encounters with other building workers broadens the individual's social circle and strengthens workplace bonds and relationships. This includes an employee's relationship to their workplace, much like soldiers to their platoons.



Ground Floor

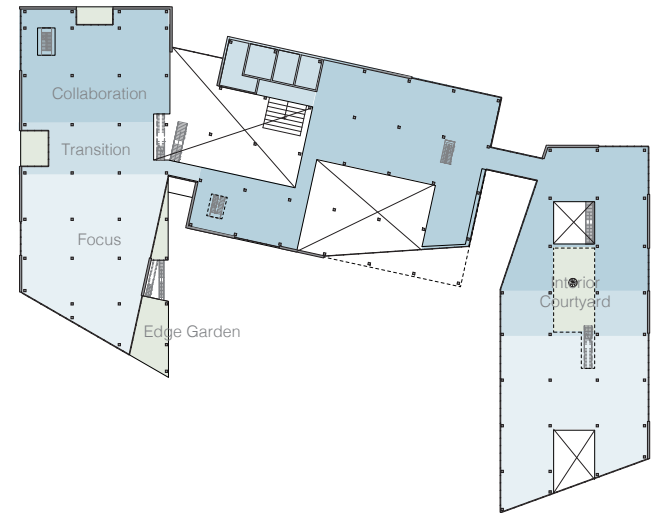

2nd Floor

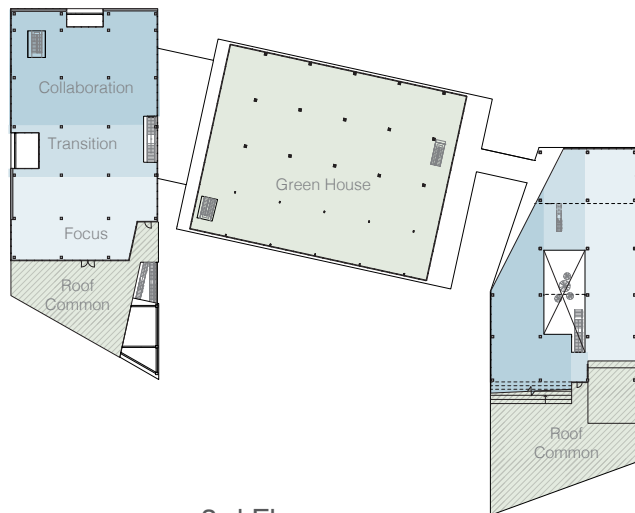

3rd Floor

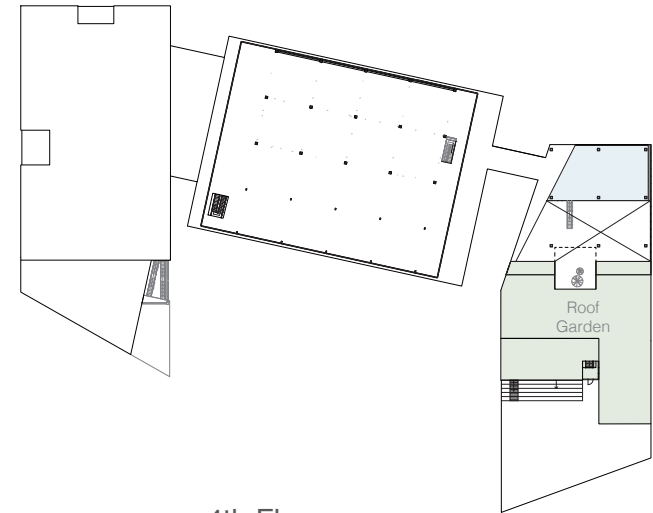

4th Floor



Fig. 31: Plans and Program

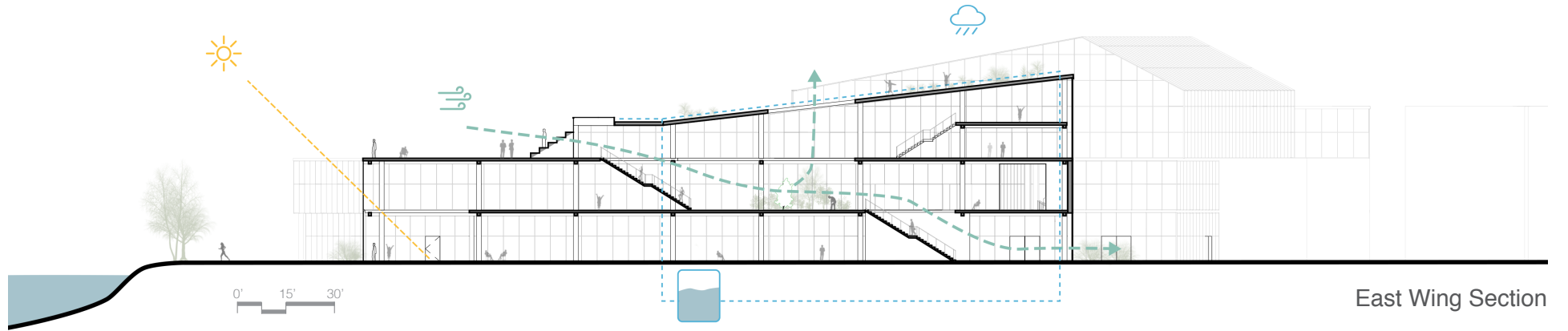

East Wing Section

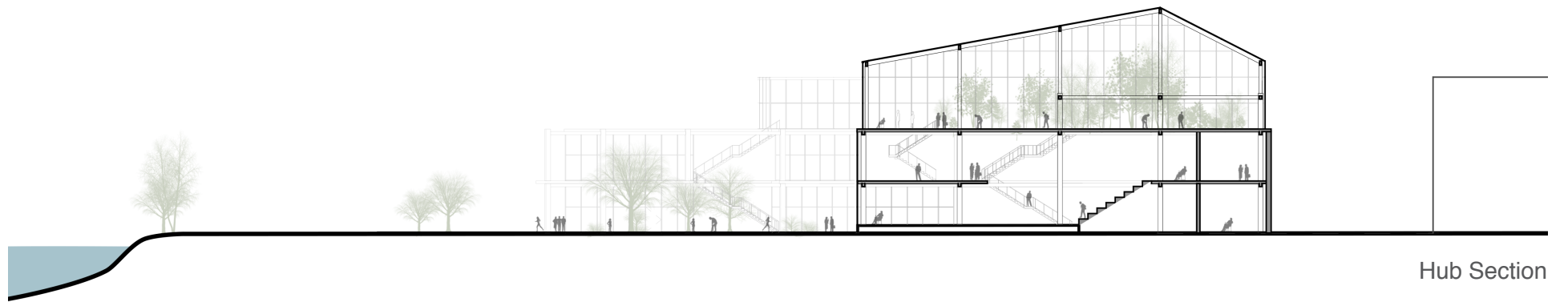

Hub Section

Fig. 32: Sections and Building Systems

## **Design Walkthrough**

This section will feature several mock-ups of my designs and elaborate on the features they show. This will enable visualization of this project's feasibility and the effects they are postulated to produce. Explaining the spaces proposed is best achieved by describing them through two perspectives; public or employee experiences.



*Fig. 33: Aerial View*

## **Public Experience**

The redesign resonates with the public from its every level, and the new massing on the roof is the most visible from this vantage point; an arterial roadway connecting downtown and uptown Seattle(Fig.33). The iconic and transparent ecologically considerate structures advertise the company's investment in sustainable design and technology, environmental responsibility, progress, and zero-mileage food production.

The features most prominent from this vantage point include

the Work Garden and the grassy sloped rooftop garden of the east wing, with glimpses of the solar paneled roof on the west wing behind the tall greenhouse atop the central building. The southern facades, equipped with curtain wall systems and automatic exterior blinds, showcase a dedication to sustainable technological strategies. This veritable advertising of Urban Cultivation will foster a reputation in the Tech industry and among the public, raising its esteem of the building's resident company therein.



*Fig. 34: Community Passage*

This public pathway encourages public activity on the site (Fig.34). The Community Passage passes the restaurant, cafe, and market and cuts through the Work Garden to connect the pedestrians from as far as the street to the lake-side Burke Gilman Trail. The Work Garden is for employees only, but guests will appreciate the sight and

function of it, reinforcing the company's commitment to innovative environmental design. The restaurant's covered patio provides another space for enjoying the landscape and Work Garden, thereby improving psychological well-being.

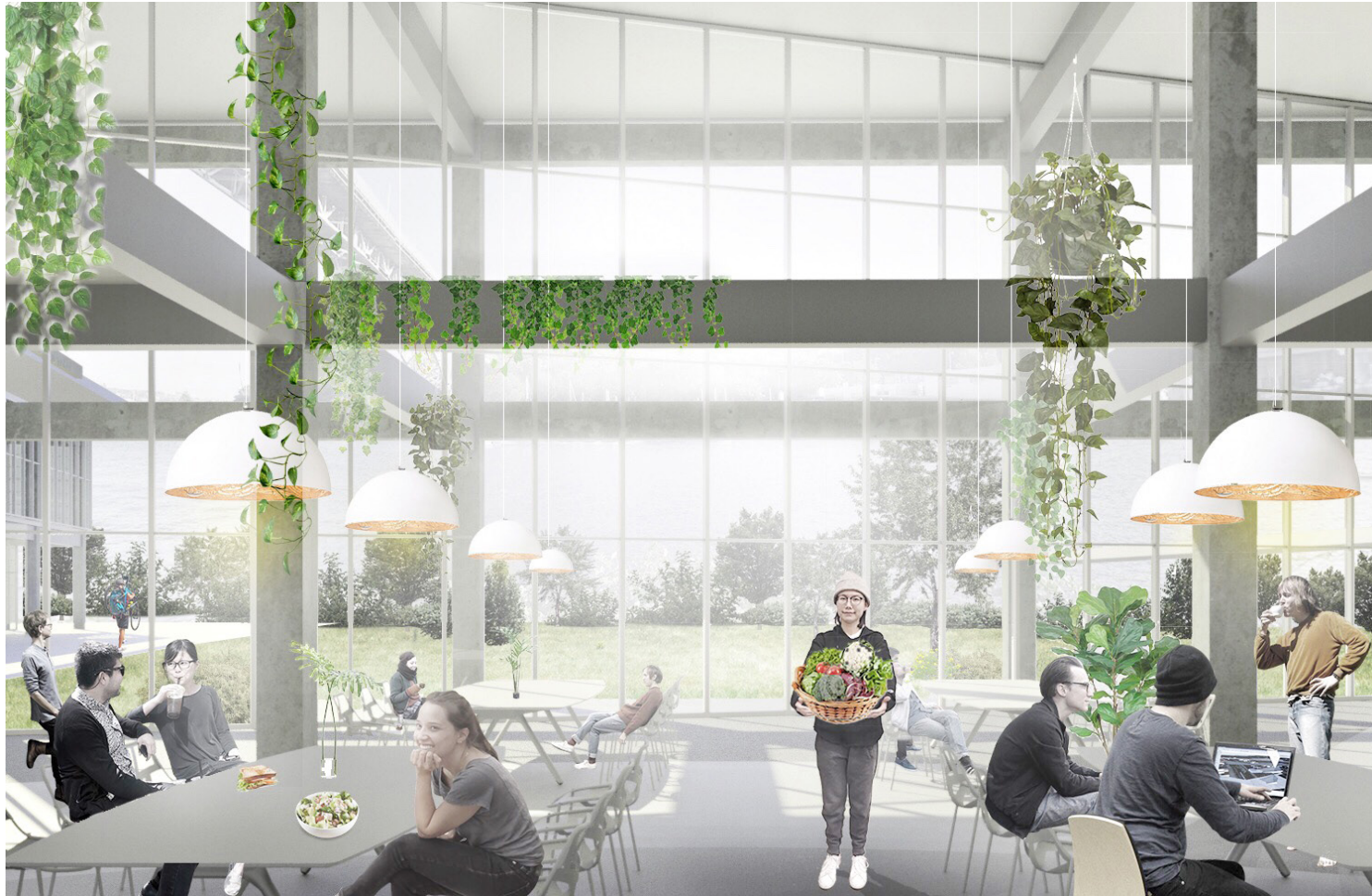

*Fig. 35: Eating Together*

This hypothetical restaurant is named Eating Together(Fig.35). It will serve zero-mileage produce cultivated and harvested on-site by employees. As a publicly accessible space, employee family and friends are welcome, as well as local residents and the employees

of other neighboring tech companies. By allowing outsiders to experience this sustainable practices, the company's reputation as an innovator will grow. This is an example of benefiting social well-being on both community and internal level.



*Fig. 36: Arrival Common*

## Employees Experience

Visible from but inaccessible to the restaurant is the Arrival Common for employees(Fig.36). This area will serve to improve social well-being as an employee lounge area. When needed, spaces

can be used for smaller collaborative work or social lounging, both by arrangement of furniture. Nature features such as indoor landscaping serve to the benefit of psychological well-being.



*Fig. 37: Cultivate*

The Cultivate, the rooftop greenhouse, is the primary food production space (Fig.37). More “green exercise” is had here as employees cultivate vegetables in planters. Studies have shown that gardening in general is an exercise that relieves stress and improves

satisfaction with one’s life. It has the added benefit of producing fresh food for nutrition. The greenhouse space features some multipurpose areas for relaxing or working, as doing so in this green space would improve well-being.



*Fig. 38: Working On The Edge Outside*

One of the sun gardens is called Working on the Edge (Fig.38). This one is on the west wing and has direct access to the Work Garden through an outdoor stairwell. The windows are

operable curtain walls that make entering the sun garden convenient. It functions as an open-air workspace, ideal for a change in surroundings to boost well-being.



*Fig. 39: Working On The Edge Inside*

Through the operable curtain walls is a focus area within the west wing (Fig.39). When those operable windows are opened, it welcomes nature into the workplace. This makes the operable windows a switch to the Mixed Mode Building. As a Mixed Mode

Building, it can operate as enclosure that relies on mechanical ventilation or the envelope can be opened to allow natural ventilation. This cultivates well-being by blurring the barriers between indoor and outdoor spaces, bringing the benefits of nature further into the office.

# Chapter 5

## Conclusion

The intent of this thesis was to examine the potential of Biophilic design and Urban Cultivation as the means of improving the well-being of tech office employees in the workplace. Contemporary tech office buildings are designed with few considerations for the health and well-being of the whole person. Isolation from nature is largely responsible for negative impacts on workers' well-being. Studies have shown that exposure to elements of nature have positive impacts on physiological, psychological, and social well-being. By expanding on Biophilic design and integrating Urban Cultivation into a site's architecture, the benefits of biophilia can be used to the advantage of businesses and their employees. Integrating Urban Cultivation in a way that engages the business' neighborhood can extend those benefits to the community.

In conducting research for this thesis, it became clear to me just how deeply architecture can be a part of human wellness. I learned much about how architecture can make connections to the community and office worker. Reviewers of this project reported their appreciation for the nontraditional workspace proposed in this thesis, especially the idea of garden-type amenities and growing fresh fruits and vegetables in the workplace. They also commended the site response and how I proposed relating it to the community.

Limits within this project exist. Namely, I did not deeply

address interior design or layout detail. My concerns were largely with designating focus and collaboration work spaces, though I did not detail how they should be situated with each other. In the future, I would explore in the future in to develop the Work Garden and office areas to detail exactly how a work day could be. For now, I have set a good base for cultivating well-being. There are a few areas that can be further developed to see its full extent. User experience always provides new data for experimental practices. For that reason, real application to include users in practice could help further develop this project.

Many existing buildings are in good relationship to their context and their fundamental structures are in good condition, making them worth keeping. As an experimental project, the affordability and sustainability of upgrading existing structures makes the project more feasible to put into practice. By hypothetically applying these methods to the Fremont Lake Union Center site, that example has demonstrated this project on redefining workplace design for the improvement of the workplace through the integration of nature in architecture. I believe that developing these methods for application to an existing structure and putting them into practice will prove my theories as I've explained them in this thesis.

# Bibliography

- Barton, J. O., & Pretty, J. (2010). What is the Best Dose of Nature and Green Exercise for Improving Mental Health ? A Multi-Study Analysis, *44*(10), 3947–3955.
- Brager, G., & Baker, L. (2008). Occupant satisfaction in mixed-mode buildings. *Center for the Built Environment*. Retrieved from <http://escholarship.org/uc/item/40k1s1vd>
- Brand, S. (1994). *How Buildings Learn*. Viking Press.
- Bullitt Center. (n.d.). Retrieved March 12, 2017, from <http://www.bullittcenter.org/>
- Bureau of Labor Statistics. (2014). Charts from the American Time Use Survey. Retrieved from <http://www.bls.gov/tus/charts/>
- Burroughs, H.E., Hansen, S. (2011). *Managing Indoor Air Quality*. The Fairmont Press, Inc. Retrieved from <https://books.google.com/books?id=KBbHmp2yisEC&lpg=PA149&ots=yTqUP4xIOx&dq=%2BASHRAE%2B%22recommended%22&pg=PA149#v=onepage&q=recommended&f=false>
- Centers for Disease Control and Prevention. (2016). Health-Related Quality of Life. Retrieved from <http://www.cdc.gov/hrqol/wellbeing.htm>
- Gould, D., Caplow, T. (2012). Building-integrated agriculture: a new approach to food production. *Metropolitan Sustainability Understanding and Improving the Urban Environment*, 147–170.
- Davis, M. C., Leach, D. J., & Clegg, C. W. (2011). The Physical Environment of the Office: Contemporary and Emerging Issues. In *International Review of Industrial and Organizational Psychology 2011* (pp. 193–237). Chichester, UK: John Wiley & Sons, Ltd. <http://doi.org/10.1002/9781119992592.ch6>
- Fjeld, T. (1998). The Effect of Indoor Foliage Plants on Health and Discomfort Symptoms among Office Workers. *Indoor+Built Environment*, *7*(4), 204.

- Frumkin, H. (2003). Healthy places: exploring the evidence. *American Journal of Public Health*, 93(9), 1451–6. Retrieved from <http://www.ncbi.nlm.nih.gov/pubmed/12948962>
- Gensler. (2013). Toward a Wellness-Based Workplace. Retrieved March 12, 2017, from <https://www.gensler.com/research-insight/research/toward-a-wellness-based-workplace?q=absenteeism>
- Kellert, S. R., Heerwagen, J., & Martin L. Mador. (2008). *Biophilic Design: The Theory, Science, and Practice of Bringing Buildings to Life*. John Wiley & Sons, Inc.
- Kim, J., & De Dear, R. (2013). Workspace satisfaction: The privacy-communication trade-off in open-plan offices. *Journal of Environmental Psychology*, 36, 18–26. <http://doi.org/10.1016/j.jenvp.2013.06.007>
- Kono Designs LLC. (2011). Pasona H.Q. Tokyo. Retrieved from <http://architizer.com/projects/pasona-hq-tokyo/>
- Lapierre, J., & Giroux, V.-P. (2003). Creativity and Work Environment in a High-Tech Context. *Creativity and Innovation Management*, 12(1), 11–23. <http://doi.org/10.1111/1467-8691.00263>
- Lottrup, L., Grahn, P., & Stigsdotter, U. K. (2013). Workplace greenery and perceived level of stress: Benefits of access to a green outdoor environment at the workplace. *Landscape and Urban Planning*, 110, 5–11. <http://doi.org/10.1016/j.landurbplan.2012.09.002>
- Martin, G., Clift, R., & Christie, I. (2016). Urban Cultivation and Its Contributions to Sustainability: Nibbles of Food but Oodles of Social Capital. *Sustainability*, 8(5), 409. <http://doi.org/10.3390/su8050409>
- Miller, N. G., & Davis, S. M. (2009). Green Buildings and Productivity see [www.josre.org](http://www.josre.org). *Forthcoming in the Journal of Sustainable Real Estate*, 1(1).
- ODPHP. (2008). 2008 Physical Activity Guidelines for Americans THE SECRETARY OF HEALTH AND HUMAN SERVICES. Retrieved from [www.health.gov/paguidelines](http://www.health.gov/paguidelines)
- Ostrovsky, A., Ribak, J., Pereg, A., & Gatton, D. (2012). Effects of job-related stress and burnout on asthenopia among high-tech workers. *Ergonomics*, 55(8), 854–862. <http://doi.org/10.1080/00140139.2012.681808>

SAMHSA. (2016). Eight Dimensions of Wellness. Retrieved from <http://www.samhsa.gov/wellness-initiative/eight-dimensions-wellness>

Singh, A., Syal, M., Grady, S. C., & Korkmaz, S. (2010). Effects of green buildings on employee health and productivity. *American Journal of Public Health, 100*(9), 1665–8. <http://doi.org/10.2105/AJPH.2009.180687>

Steelcase. (2016). *Privacy Ideabook*. Retrieved from <https://www.steelcase.com/content/uploads/2015/01/power-of-place-privacy-ideabook.pdf>

Stuart, H. (2015). Companies Are Rethinking The Open Office, And It's About Time. *The Huffington Post*. Retrieved from [http://www.huffingtonpost.com/2015/02/12/open-offices-changing-to-include-private-space\\_n\\_6669666.html](http://www.huffingtonpost.com/2015/02/12/open-offices-changing-to-include-private-space_n_6669666.html)